

BS ISO 3302-1:2014



BSI Standards Publication

# Rubber — Tolerances for products

Part 1: Dimensional tolerances

**bsi.**

...making excellence a habit.™

**National foreword**

This British Standard is the UK implementation of ISO 3302-1:2014. It supersedes BS 3734-1:1997 which is withdrawn.

The UK participation in its preparation was entrusted to Technical Committee PRI/73, Industrial rubber products.

A list of organizations represented on this committee can be obtained on request to its secretary.

This publication does not purport to include all the necessary provisions of a contract. Users are responsible for its correct application.

© The British Standards Institution 2014. Published by BSI Standards Limited 2014

ISBN 978 0 580 81957 5

ICS 83.140.01

**Compliance with a British Standard cannot confer immunity from legal obligations.**

This British Standard was published under the authority of the Standards Policy and Strategy Committee on 31 July 2014.

**Amendments issued since publication**

Date	Text affected
------	---------------

---

INTERNATIONAL  
STANDARD

**ISO**  
**3302-1**

Second edition  
2014-07-15

---

---

**Rubber — Tolerances for products —**  
**Part 1:**  
**Dimensional tolerances**

*Caoutchouc — Tolérances pour produits —*  
*Partie 1: Tolérances dimensionnelles*



Reference number  
ISO 3302-1:2014(E)



**COPYRIGHT PROTECTED DOCUMENT**

© ISO 2014

All rights reserved. Unless otherwise specified, no part of this publication may be reproduced or utilized otherwise in any form or by any means, electronic or mechanical, including photocopying, or posting on the internet or an intranet, without prior written permission. Permission can be requested from either ISO at the address below or ISO's member body in the country of the requester.

ISO copyright office  
Case postale 56 • CH-1211 Geneva 20  
Tel. + 41 22 749 01 11  
Fax + 41 22 749 09 47  
E-mail [copyright@iso.org](mailto:copyright@iso.org)  
Web [www.iso.org](http://www.iso.org)

Published in Switzerland

# Contents

	Page
<b>Foreword</b> .....	<b>iv</b>
<b>Introduction</b> .....	<b>v</b>
<b>1 Scope</b> .....	<b>1</b>
<b>2 Normative references</b> .....	<b>1</b>
<b>3 Measurement of dimensions</b> .....	<b>1</b>
3.1 General .....	1
3.2 Test instruments .....	2
<b>4 Tolerances</b> .....	<b>2</b>
<b>5 Mouldings</b> .....	<b>2</b>
5.1 General .....	2
5.2 Classification .....	3
5.3 Fixed dimensions and closure dimensions .....	3
5.4 Tolerances .....	3
5.5 Flash .....	5
<b>6 Extrusions</b> .....	<b>5</b>
6.1 General .....	5
6.2 Classification .....	6
6.3 Tolerances .....	6
<b>7 Calendered sheet</b> .....	<b>9</b>
7.1 General .....	9
7.2 Classification .....	10
7.3 Tolerances .....	10

## Foreword

ISO (the International Organization for Standardization) is a worldwide federation of national standards bodies (ISO member bodies). The work of preparing International Standards is normally carried out through ISO technical committees. Each member body interested in a subject for which a technical committee has been established has the right to be represented on that committee. International organizations, governmental and non-governmental, in liaison with ISO, also take part in the work. ISO collaborates closely with the International Electrotechnical Commission (IEC) on all matters of electrotechnical standardization.

The procedures used to develop this document and those intended for its further maintenance are described in the ISO/IEC Directives, Part 1. In particular the different approval criteria needed for the different types of ISO documents should be noted. This document was drafted in accordance with the editorial rules of the ISO/IEC Directives, Part 2 (see [www.iso.org/directives](http://www.iso.org/directives)).

Attention is drawn to the possibility that some of the elements of this document may be the subject of patent rights. ISO shall not be held responsible for identifying any or all such patent rights. Details of any patent rights identified during the development of the document will be in the Introduction and/or on the ISO list of patent declarations received (see [www.iso.org/patents](http://www.iso.org/patents)).

Any trade name used in this document is information given for the convenience of users and does not constitute an endorsement.

For an explanation on the meaning of ISO specific terms and expressions related to conformity assessment, as well as information about ISO's adherence to the WTO principles in the Technical Barriers to Trade (TBT) see the following URL: Foreword - Supplementary information

The committee responsible for this document is ISO/TC 45, *Rubber and rubber products*, Subcommittee SC 4, *Products (other than hoses)*.

This second edition cancels and replaces the first edition (ISO 3302-1:1996), which has been technically revised to incorporate the Amendment ISO 3302-2:1996/Amd.1:2001.

ISO 3302 consists of the following parts, under the general title *Rubber — Tolerances for products*:

- *Part 1: Dimensional tolerances*
- *Part 2: Geometrical tolerances*

## Introduction

Rubber products are subject to changes in their dimensions after processing and vulcanization. This can be due to a variety of factors, such as mould shrinkage or relaxation of die swell.

These changes should be determined and allowed for when designing such items as moulds and dies used in the manufacture of a given product.

The closer tolerance classes outlined in this specification are not to be demanded unless required by the final application and are to be restricted to those dimensions deemed to be critical. The greater the degree of accuracy demanded, the closer the control to be exercised during manufacture, and hence the higher the costs.

When particular physical properties are required in the product, it might not always be possible to provide them in a mix which is capable of fabrication to close tolerances. It is advisable, in these circumstances, that consultation should take place between the interested parties. In general, softer vulcanizates (i.e. those of hardness below 50 IRHD - see ISO 48) need greater tolerances than harder ones.





# Rubber — Tolerances for products —

## Part 1: Dimensional tolerances

### 1 Scope

This part of ISO 3302 specifies classes of dimensional tolerances and their values for moulded, extruded, and calendared solid rubber products. The relevant test methods necessary for the establishment of compliance with this part of ISO 3302 are also specified.

The tolerances are primarily intended for use with vulcanized rubber but can also be suitable for products made of thermoplastic rubbers.

This part of ISO 3302 does not apply to precision toroidal sealing rings or to calendared composite products such as rubber-coated fabrics or products where a rubber coating is applied by the process of topping or skim coating.

### 2 Normative references

The following documents, in whole or in part, are normatively referenced in this document and are indispensable for its application. For dated references, only the edition cited applies. For undated references, the latest edition of the referenced document (including any amendments) applies.

ISO 3, *Preferred numbers — Series of preferred numbers*

ISO 48, *Rubber, vulcanized or thermoplastic — Determination of hardness (hardness between 10 IRHD and 100 IRHD)*

ISO 2230, *Rubber products — Guidelines for storage*

ISO 23529, *Rubber — General procedures for preparing and conditioning test pieces for physical test methods*

### 3 Measurement of dimensions

#### 3.1 General

For solid products, measurements of dimensions shall not be made until 16 h have elapsed after vulcanization, this minimum time is being extended to 72 h in cases of dispute. Measurements shall be completed within 3 months after the date of despatch to the purchaser or before the product is put into use, whichever is the shorter time. Measurements shall be made at standard temperature, after conditioning, in accordance with ISO 23529. Care shall be taken to ensure that the products are not subjected to adverse storage conditions in accordance with ISO 2230, and that they are not distorted during measurement.

## 3.2 Test instruments

**3.2.1** Depending on the circumstances, measurements shall be made using one or more of the following types of instrument.

**3.2.1.1** For solid products, a **micrometre dial gauge**, the foot of which shall exert a pressure of 22 kPa  $\pm$  5 kPa for rubber of hardness equal to or greater than 35 IRHD or of 10 kPa  $\pm$  2 kPa for rubber of hardness less than 35 IRHD as specified in ISO 23529 and ISO 48.

**3.2.1.2** A **suitable optical measuring instrument**.

**3.2.1.3** **Fixed gauges**, for upper and lower limits appropriate to the dimensions being measured.

**3.2.1.4** **Other devices**, including tape measures (with or without vernier), sliding calipers, and micrometre calipers.

**3.2.2** All instruments shall be capable of measuring the dimension with an error within the tolerances specified.

**3.2.3** In all measurements intended to be comparative, the same measuring device shall be used.

## 4 Tolerances

For the purposes of this part of ISO 3302, nominal dimensions and tolerances are based on the R 5 and R 10 series of preferred numbers, respectively, in accordance with ISO 3.

The dimensions of certain parameters of a particular product may not all require the application of the same class of tolerance. Dimensions of different parameters of the product on the same drawing can have different class tolerances applied to them. When drawings do not indicate a class tolerance, the largest tolerance given in the related table shall be applied.

NOTE 1 Tolerances that are specified in this part of ISO 3302 in terms of a positive value and an equal negative value (e.g.  $\pm 0,35$ ) can also be expressed in terms of unequal positive and negative values, providing the difference between the two values remains the same. For example,  $\pm 0,35$  may also be expressed as  $_{-0,5}^{+0,2}$  or  $_{0}^{+0,7}$  or  $_{-0,7}^{0}$  etc.

NOTE 2 Special consideration of tolerances will be necessary for a vulcanizate with a low hardness and a high tensile strength (e.g. natural rubber gum vulcanizate).

## 5 Mouldings

### 5.1 General

The dimensional tolerances stated in this part of ISO 3302 may be wider than those used in some other engineering practice. The following considerations apply.

- a) All rubber shows some shrinkage when cooled after moulding, and for this is made in the mould design. The amount of shrinkage is dependent on the rubber type and the mix used, but also varies from batch to batch of the same mix. Products made from some silicone rubbers, fluorocarbon elastomers, and other special-purpose elastomers are subject to larger shrinkages; therefore, tolerance classes M1 and M2 (see [5.2](#)) are very difficult to obtain with these rubbers.
- b) Non-rubber parts bonded to the rubber will affect the shrinkage and, therefore, the practicable tolerances.

- c) Moulds are made in various ways depending on the type of product and accuracy demanded. In general, product can be no more accurate than the mould, and the greater the degree of accuracy demanded, the more expensive the moulds and their maintenance become.
- d) Care shall be taken in applying the standard tolerances to products having wide sectional variations.
- e) In cases where the rubber product is unavoidably distorted during removal from the mould, the dimensions of the products can be affected, and special allowance might be needed.

## 5.2 Classification

This subclause establishes four classes of tolerance for fixed and closure dimensions (see [5.3](#)) for products moulded in solid rubber.

- a) Class M1 for precision mouldings. Such mouldings require precision moulds, fewer cavities per mould, close mix controls, etc., which results in high cost. Optical comparators or other, similar, measuring devices might be required to minimize distortion of the rubber by the measuring instrument. This type of part requires expensive control and inspection procedures.
- b) Class M2 for high-quality mouldings involving much of the close control required for class M1.
- c) Class M3 for good-quality mouldings.
- d) Class M4 for mouldings where dimensional control is non-critical.

A classification system for flash is given in [5.5](#).

## 5.3 Fixed dimensions and closure dimensions

In moulding a rubber product, more rubber is used than is required to fill the cavity, and the excess is flashed. This flash tends to prevent the mould sections from fully closing and, thus, affects the finished part dimensions.

NOTE For products moulded by transfer or injection, it is possible to regard all dimensions as fixed.

Two sets of tolerances, F and C, are given and are defined below.

**5.3.1 Fixed dimensions (F):** Dimensions which are not affected by deforming influences like flash thickness or lateral displacement of different mould parts (upper and lower parts or cores). See [Figure 1](#), dimensions  $l_1$ ,  $l_2$ , and  $l_3$ .

**5.3.2 Closure dimensions (C):** Dimensions which can be altered by variation in the flash thickness or lateral displacement of different mould parts. See [Figure 1](#), dimensions  $d_1$ ,  $d_2$ ,  $d_3$ , and  $h$ .

NOTE The dimensions for F and C can only be tolerance insofar as they are independent of each other.

## 5.4 Tolerances

The tolerances to be applied shall be chosen, by agreement between the interested parties, from the classes of tolerance described in [5.2](#).

Standard tolerances are given in [Table 1](#). Fixed tolerances (F) are related by size to each dimension, but all closure tolerances (C) are determined by the largest closure dimension ( $h$ , see [Figure 1](#)).

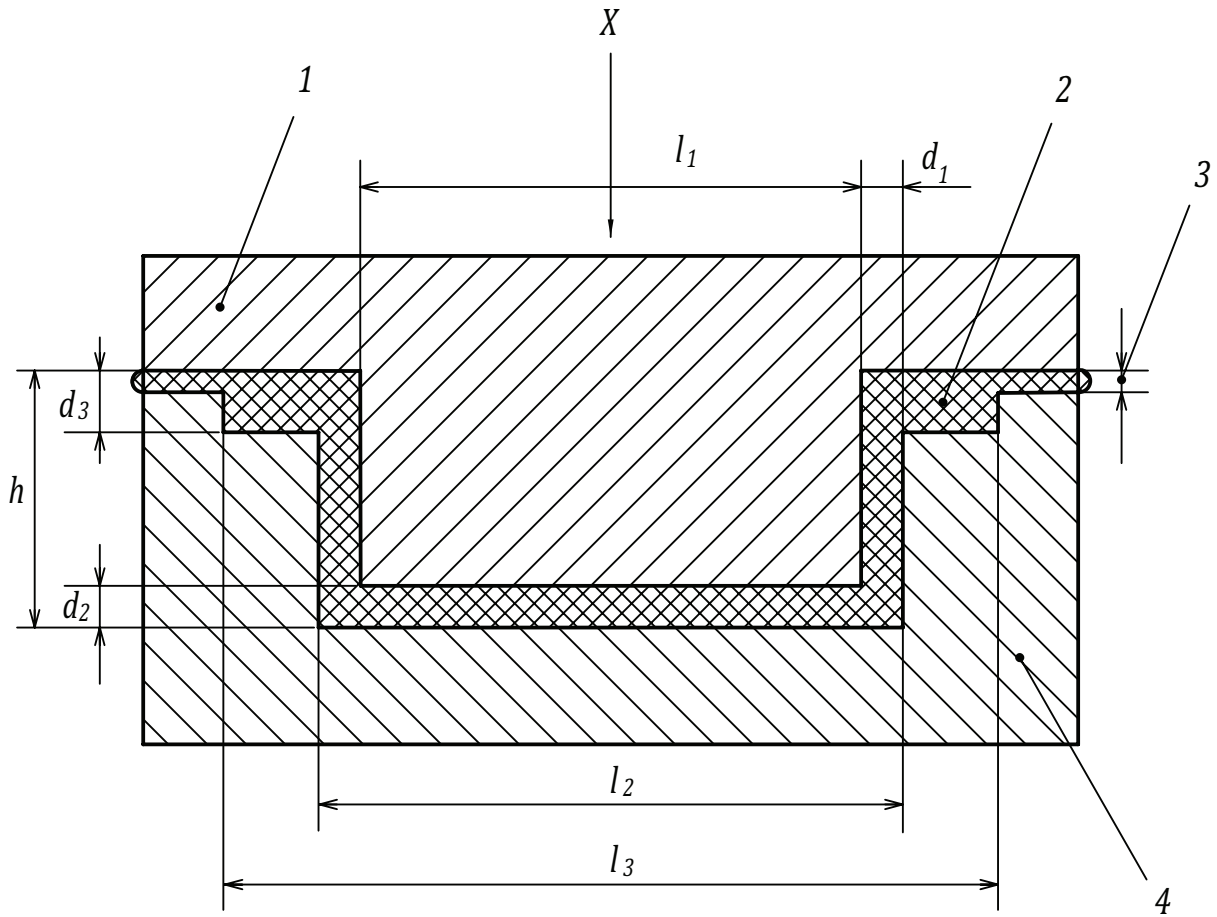

**Key**

- X direction of pressure
- 1 upper half of mould
- 2 moulded part
- 3 flash
- 4 lower half of mould

**Figure 1 — Compression mould and moulded part (diagrammatic)**

**Table 1 — Tolerances for mouldings**

Dimensions in millimetres (unless indicated otherwise)

Nominal dimension		Class M1		Class M2		Class M3		Class M4
Above	up to and including	F ±	C ±	F ±	C ±	F ±	C ±	F and C ±
0	4,0	0,08	0,10	0,10	0,15	0,25	0,40	0,50
4,0	6,3	0,10	0,12	0,15	0,20			
6,3	10	0,10	0,15	0,20	0,20	0,30	0,50	0,70
10	16	0,15	0,20	0,20	0,25	0,40	0,60	0,80
16	25	0,20	0,20	0,25	0,35	0,50	0,80	1,00
25	40	0,20	0,25	0,35	0,40	0,60	1,00	1,30
40	63	0,25	0,35	0,40	0,50	0,80	1,30	1,60
63	100	0,35	0,40	0,50	0,70	1,00	1,60	2,00
100	160	0,40	0,50	0,70	0,80	1,30	2,00	2,50
160	—	0,3 %	0,4 %	0,5 %	0,7 %	0,8 %	1,3 %	1,5 %

## 5.5 Flash

This subclause establishes six classes of flash, as listed in [Table 2](#).

**Table 2 — Classes of flash**

Class	Maximum height of flash mm	Description
X0	0	No flash <sup>a</sup>
X1	0,1	Precision flash
X2	0,5	Accurate flash
X3	1,0	Normal flash
X4	2,0	Rough flash
X5	No limit	Non-critical

<sup>a</sup> Class X0 can only apply to those surfaces of an article which do not have parting lines.

## 6 Extrusions

### 6.1 General

Extruded rubber products require greater tolerances in manufacture than those produced by moulding since the rubber undergoes die swell and, during subsequent vulcanization, shrinkage and deformation usually occur.

Deformation can be reduced by the use of supports during vulcanization, the nature of the support depending on the section being produced, and the degree of control required. Such features determine the class of tolerance applicable to given dimensions.

In the case of certain synthetic rubbers, extrusion class E1 tolerances are not directly obtainable.

## 6.2 Classification

This subclause establishes 11 classes of tolerance for extrusions in solid rubber, related to particular ranges of dimensions.

- a) Three classes of tolerance on nominal cross sectional dimensions of unsupported extrusions:
- |    |              |
|----|--------------|
| E1 | high quality |
| E2 | good quality |
| E3 | non-critical |
- b) Three classes of tolerance on nominal cross sectional dimensions of mandrel-supported extrusions:
- |     |              |
|-----|--------------|
| EN1 | precision    |
| EN2 | high quality |
| EN3 | good quality |
- c) Two classes of tolerance (EG) on outside dimensions (nominal diameters) of surface-ground extrusions (tubing) together with two classes of tolerance (EW) on wall thickness of these extrusions:
- |             |              |
|-------------|--------------|
| EG1 and EW1 | precision    |
| EG2 and EW2 | good quality |
- d) Three classes of tolerance (L) for the cut length of extrusions, and three classes of tolerance (EC) on the thickness of cut sections of extrusions:
- |            |              |
|------------|--------------|
| L1 and EC1 | precision    |
| L2 and EC2 | good quality |
| L3 and EC3 | non-critical |

## 6.3 Tolerances

### 6.3.1 General

The tolerances to be applied shall be chosen, by agreement between the interested parties, from the classes of tolerance described in [6.2](#).

Standard tolerances are given in [Tables 3 to 8](#).

In any extruded cross section, the dimensions of only two of the three variables (i.e. inside dimensions, outside dimensions and wall thickness) can be tolerance to control the dimensions of the cross section.

### 6.3.2 Unsupported extrusions

The tolerances on the cross sectional dimensions of unsupported extrusions are given in [Table 3](#).

For hollow extrusions or extrusions having a complex section, a certain amount of collapse can occur during vulcanization. It is possible to limit or prevent this collapse by putting the extrusions on mandrels or on formers. The amount of the permitted deformation of the section shall be stated by the purchaser.

**Table 3 — Tolerances on cross-sectional dimensions of unsupported extrusions**

Dimensions in millimetres

Nominal dimension		Class E1 ±	Class E2 ±	Class E3 ±
above	up to and including			
0	1,5	0,15	0,25	0,40
1,5	2,5	0,20	0,35	0,50
2,5	4,0	0,25	0,40	0,70
4,0	6,3	0,35	0,50	0,80
6,3	10,0	0,40	0,70	1,00
10	16	0,50	0,80	1,30
16	25	0,70	1,00	1,60
25	40	0,80	1,30	2,00
40	63	1,00	1,60	2,50
63	100	1,30	2,00	3,20
100	-	1,3 %	2 %	3,2 %

### 6.3.3 Mandrel-supported extrusions

Vulcanization of hollow extrusions can be carried out on mandrels to achieve closer tolerances on internal dimensions than can be obtained without support. This can apply to tubing from which rings or washers are subsequently cut. Shrinkage usually occurs when the product is removed from the mandrel, so that the resulting size of the mandrel-supported dimension is smaller than the mandrel size. The dimension can, however, be larger should the positive tolerance for the mandrel exceed the shrinkage of the extrudate, and in this case both positive and negative tolerances will need to be applied.

The tolerances on internal dimensions of mandrel supported extrusions are given in [Table 4](#). The positive tolerance is intended to cater for any tolerances that can apply to the mandrel itself and for this reason no change of tolerance in either direction is permitted for the internal dimension; the negative tolerances specified in [Table 4](#) shall not be increased.

**Table 4 — Tolerances on internal dimensions of mandrel-supported extrusions**

Dimensions in millimetres (unless indicated otherwise)

Nominal dimension		Class EN1 ±	Class EN2 ±	Class EN3 ±
above	up to and including			
0	4	0,20	0,20	0,35
4	6,3	0,20	0,25	0,40
6,3	10	0,25	0,35	0,50
10	16	0,35	0,40	0,70
16	25	0,40	0,50	0,80
25	40	0,50	0,70	1,00
40	63	0,70	0,80	1,30
63	100	0,80	1,00	1,60
100	160	1,00	1,30	2,00
160	—	0,6 %	0,8 %	1,2 %

### 6.3.4 Surface-ground extrusions

6.3.4.1 The tolerances on the outside dimensions (usually diameter) of surface-ground extrusions (normally tubing) are given in [Table 5](#).

NOTE These tolerances are also applicable to rings cut from surface-ground tubing.

**Table 5 — Tolerances on outside dimensions of surface-ground extrusions**

Dimensions in millimetres (unless indicated otherwise)

Nominal dimension		Class EG1 ±	Class EG2 ±
above	up to and including		
0	10	0,15	0,25
10	16	0,20	0,35
16	25	0,20	0,40
25	40	0,25	0,50
40	63	0,35	0,70
63	100	0,40	0,80
100	160	0,50	1,00
160	—	0,3 %	0,5 %

6.3.4.2 The tolerances on the wall thickness of surface-ground extrusions (normally tubing) are given in [Table 6](#).

**Table 6 — Tolerances on wall thickness of surface-ground extrusions**

Dimensions in millimetres

Nominal dimension		Class EW1 ±	Class EW2 ±
above	up to and including		
0	4	0,10	0,20
4	6,3	0,15	0,20
6,3	10	0,20	0,25
10	16	0,20	0,35
16	25	0,25	0,40

### 6.3.5 Cut lengths

The tolerances on the cut length of extrusions are given in [Table 7](#).



**Table 7 — Tolerances on cut length of extrusions**

Dimensions in millimetres (unless indicated otherwise)

Nominal dimension		Class L1	Class L2	Class L3
above	up to and including			
0	40	± 0,7	± 1,0	± 1,6
40	63	± 0,8	± 1,3	± 2,0
63	100	± 1,0	± 1,6	± 2,5
100	160	± 1,3	± 2,0	± 3,2
160	250	± 1,6	± 2,5	± 4,0
250	400	± 2,0	± 3,2	± 5,0
400	630	± 2,5	± 4,0	± 6,3
630	1 000	± 3,2	± 5,0	± 10,0
1 000	1 600	± 4,0	± 6,3	± 12,5
1 600	2 500	± 5,0	± 10,0	± 16,0
2 500	4 000	± 6,3	± 12,5	± 20,0
4 000	—	± 0,16 %	± 0,32 %	± 0,50 %

### 6.3.6 Cut sections

The tolerances on the thickness of cut sections (for example rings, washers, discs) are given in [Table 8](#).

NOTE Tolerance classes EC1 and EC2 can be obtained only for lathe-cut sections.

**Table 8 — Tolerances on thickness of cut sections of extrusions**

Dimensions in millimetres

Nominal dimension		Class EC1	Class EC2	Class EC3
above	up to and including			
0,63	1,00	± 0,10	± 0,15	± 0,20
1,00	1,60	± 0,10	± 0,20	± 0,25
1,60	2,50	± 0,15	± 0,20	± 0,35
2,50	4,00	± 0,20	± 0,25	± 0,40
4,00	6,30	± 0,20	± 0,35	± 0,50
6,30	10	± 0,25	± 0,40	± 0,70
10	16	± 0,35	± 0,50	± 0,80
16	25	± 0,40	± 0,70	± 1,00

## 7 Calendered sheet

### 7.1 General

For calendered sheet, considerations and limitations similar to those for extruded rubber products apply, particularly with regard to swelling of the rubber on passage between calender rolls and to any deformation before and during vulcanization.

The tolerance chosen will also depend on the surface finish of the sheeting. Larger thickness tolerances are required with cloth-finished sheet than with smooth or press-finished sheet.

## 7.2 Classification

This subclause establishes six classes of tolerance for calendered sheet of solid rubber, related to particular ranges of dimensions.

a) Three classes of tolerance on nominal thickness:

- ST1 precision
- ST2 high quality
- ST3 good quality

b) Three classes of tolerance on nominal width:

- SW1 high quality
- SW2 good quality
- SW3 non-critical

## 7.3 Tolerances

The tolerances to be applied shall be chosen, by agreement between the interested parties, from the classes of tolerance described in 7.2.

Standard tolerances are given in [Tables 9](#) and [10](#).

**Table 9 — Tolerances on thickness of calendered sheet**

Dimensions in millimetres (unless indicated otherwise)

Nominal dimension		Class ST1 ±	Class ST2 ±	Class ST3 ±
above	up to and including			
0	1,00	0,15	0,20	0,25
1,00	1,60	0,15	0,25	0,35
1,60	2,50	0,20	0,35	0,40
2,50	4,00	0,25	0,40	0,50
4,00	6,30	0,35	0,50	0,70
6,30	10	0,40	0,70	0,80
10	16	0,50	0,80	1,00
16	—	3,5 %	5 %	7 %

**Table 10 — Tolerances on width of calendered sheet**

Dimensions in millimetres (unless indicated otherwise)

Nominal dimension		Class SW1 ±	Class SW2 ±	Class SW3 ±
above	up to and including			
630	1 000	20	25	30
1 000	1 600	30	40	50
1 600	—	2 %	2,5 %	3 %







# British Standards Institution (BSI)

BSI is the national body responsible for preparing British Standards and other standards-related publications, information and services.

BSI is incorporated by Royal Charter. British Standards and other standardization products are published by BSI Standards Limited.

## About us

We bring together business, industry, government, consumers, innovators and others to shape their combined experience and expertise into standards-based solutions.

The knowledge embodied in our standards has been carefully assembled in a dependable format and refined through our open consultation process. Organizations of all sizes and across all sectors choose standards to help them achieve their goals.

## Information on standards

We can provide you with the knowledge that your organization needs to succeed. Find out more about British Standards by visiting our website at [bsigroup.com/standards](http://bsigroup.com/standards) or contacting our Customer Services team or Knowledge Centre.

## Buying standards

You can buy and download PDF versions of BSI publications, including British and adopted European and international standards, through our website at [bsigroup.com/shop](http://bsigroup.com/shop), where hard copies can also be purchased.

If you need international and foreign standards from other Standards Development Organizations, hard copies can be ordered from our Customer Services team.

## Subscriptions

Our range of subscription services are designed to make using standards easier for you. For further information on our subscription products go to [bsigroup.com/subscriptions](http://bsigroup.com/subscriptions).

With **British Standards Online (BSOL)** you'll have instant access to over 55,000 British and adopted European and international standards from your desktop. It's available 24/7 and is refreshed daily so you'll always be up to date.

You can keep in touch with standards developments and receive substantial discounts on the purchase price of standards, both in single copy and subscription format, by becoming a **BSI Subscribing Member**.

**PLUS** is an updating service exclusive to BSI Subscribing Members. You will automatically receive the latest hard copy of your standards when they're revised or replaced.

To find out more about becoming a BSI Subscribing Member and the benefits of membership, please visit [bsigroup.com/shop](http://bsigroup.com/shop).

With a **Multi-User Network Licence (MUNL)** you are able to host standards publications on your intranet. Licences can cover as few or as many users as you wish. With updates supplied as soon as they're available, you can be sure your documentation is current. For further information, email [bsmusales@bsigroup.com](mailto:bsmusales@bsigroup.com).

## Revisions

Our British Standards and other publications are updated by amendment or revision.

We continually improve the quality of our products and services to benefit your business. If you find an inaccuracy or ambiguity within a British Standard or other BSI publication please inform the Knowledge Centre.

## Copyright

All the data, software and documentation set out in all British Standards and other BSI publications are the property of and copyrighted by BSI, or some person or entity that owns copyright in the information used (such as the international standardization bodies) and has formally licensed such information to BSI for commercial publication and use. Except as permitted under the Copyright, Designs and Patents Act 1988 no extract may be reproduced, stored in a retrieval system or transmitted in any form or by any means – electronic, photocopying, recording or otherwise – without prior written permission from BSI. Details and advice can be obtained from the Copyright & Licensing Department.

## Useful Contacts:

### Customer Services

**Tel:** +44 845 086 9001

**Email (orders):** [orders@bsigroup.com](mailto:orders@bsigroup.com)

**Email (enquiries):** [cservices@bsigroup.com](mailto:cservices@bsigroup.com)

### Subscriptions

**Tel:** +44 845 086 9001

**Email:** [subscriptions@bsigroup.com](mailto:subscriptions@bsigroup.com)

### Knowledge Centre

**Tel:** +44 20 8996 7004

**Email:** [knowledgecentre@bsigroup.com](mailto:knowledgecentre@bsigroup.com)

### Copyright & Licensing

**Tel:** +44 20 8996 7070

**Email:** [copyright@bsigroup.com](mailto:copyright@bsigroup.com)

## BSI Group Headquarters

389 Chiswick High Road London W4 4AL UK



...making excellence a habit.™