



BSI Standards Publication

# Machine tools — Test conditions for testing the accuracy of boring and milling machines with horizontal spindle

Part 2: Machines with movable column along the X-axis (floor type)

**National foreword**

This British Standard is the UK implementation of ISO 3070-2:2016. It supersedes BS ISO 3070-2:2007 which is withdrawn.

The UK participation in its preparation was entrusted to Technical Committee MTE/1/2, Machine tools - Accuracy.

A list of organizations represented on this committee can be obtained on request to its secretary.

This publication does not purport to include all the necessary provisions of a contract. Users are responsible for its correct application.

© The British Standards Institution 2016.  
Published by BSI Standards Limited 2016

ISBN 978 0 580 78991 5

ICS 25.080.20

**Compliance with a British Standard cannot confer immunity from legal obligations.**

This British Standard was published under the authority of the Standards Policy and Strategy Committee on 31 August 2016.

**Amendments/corrigenda issued since publication**

| Date | Text affected |
|------|---------------|
|------|---------------|

---

---

---

**Machine tools — Test conditions for  
testing the accuracy of boring and  
milling machines with horizontal  
spindle —**

Part 2:

**Machines with movable column along  
the X-axis (floor type)**

*Machines-outils — Conditions d'essai pour le contrôle de l'exactitude  
des machines à aléser et à fraiser à broche horizontale —*

*Partie 2: Machines à montant mobile le long de l'axe X (de type au sol)*





**COPYRIGHT PROTECTED DOCUMENT**

© ISO 2016, Published in Switzerland

All rights reserved. Unless otherwise specified, no part of this publication may be reproduced or utilized otherwise in any form or by any means, electronic or mechanical, including photocopying, or posting on the internet or an intranet, without prior written permission. Permission can be requested from either ISO at the address below or ISO's member body in the country of the requester.

ISO copyright office  
Ch. de Blandonnet 8 • CP 401  
CH-1214 Vernier, Geneva, Switzerland  
Tel. +41 22 749 01 11  
Fax +41 22 749 09 47  
copyright@iso.org  
www.iso.org

# Contents

|   | Page      |
|---|-----------|
| <b>Foreword</b> .....   | <b>iv</b> |
| <b>Introduction</b> .....   | <b>v</b>  |
| <b>1 Scope</b> .....  | <b>1</b>  |
| <b>2 Normative references</b> .....   | <b>1</b>  |
| <b>3 Terms and definitions</b> .....  | <b>2</b>  |
| <b>4 Terminology and designation of axes</b> .....  | <b>2</b>  |
| <b>5 Special remarks concerning particular elements</b> .....                                     | <b>3</b>  |
| 5.1 Spindle heads.....  | 3         |
| 5.2 Tables.....   | 4         |
| <b>6 Preliminary remarks</b> .....  | <b>5</b>  |
| 6.1 Measurement units.....  | 5         |
| 6.2 Reference to ISO 230 series of standards.....   | 5         |
| 6.3 Testing sequence.....   | 5         |
| 6.4 Tests to be performed.....  | 5         |
| 6.5 Measuring instruments.....  | 5         |
| 6.6 Software compensation.....  | 6         |
| 6.7 Minimum tolerance.....  | 6         |
| <b>7 Geometric tests</b> .....  | <b>7</b>  |
| 7.1 Straightness and angular deviations of linear axes.....                                       | 7         |
| 7.2 Squareness and parallelism between linear axes.....   | 13        |
| 7.3 Fixed table independent of the machine.....   | 18        |
| 7.4 Boring spindle.....   | 22        |
| 7.5 Milling spindle.....  | 26        |
| 7.6 Rotary and movable table.....   | 28        |
| 7.7 Indexing or rotary tables.....  | 35        |
| <b>8 Checking accuracy and repeatability of positioning by numerical control</b> .....            | <b>37</b> |
| <b>Annex A (informative) Geometric accuracy of axis of rotation</b> .....                         | <b>44</b> |
| <b>Annex B (normative) Tests of accessory facing heads [see <a href="#">Figure 2 b</a>]</b> ..... | <b>48</b> |
| <b>Annex C (informative) Nomenclature of machine tool components in other languages</b> .....     | <b>52</b> |
| <b>Bibliography</b> .....   | <b>53</b> |

## Foreword

ISO (the International Organization for Standardization) is a worldwide federation of national standards bodies (ISO member bodies). The work of preparing International Standards is normally carried out through ISO technical committees. Each member body interested in a subject for which a technical committee has been established has the right to be represented on that committee. International organizations, governmental and non-governmental, in liaison with ISO, also take part in the work. ISO collaborates closely with the International Electrotechnical Commission (IEC) on all matters of electrotechnical standardization.

The procedures used to develop this document and those intended for its further maintenance are described in the ISO/IEC Directives, Part 1. In particular the different approval criteria needed for the different types of ISO documents should be noted. This document was drafted in accordance with the editorial rules of the ISO/IEC Directives, Part 2 (see [www.iso.org/directives](http://www.iso.org/directives)).

Attention is drawn to the possibility that some of the elements of this document may be the subject of patent rights. ISO shall not be held responsible for identifying any or all such patent rights. Details of any patent rights identified during the development of the document will be in the Introduction and/or on the ISO list of patent declarations received (see [www.iso.org/patents](http://www.iso.org/patents)).

Any trade name used in this document is information given for the convenience of users and does not constitute an endorsement.

For an explanation on the meaning of ISO specific terms and expressions related to conformity assessment, as well as information about ISO's adherence to the World Trade Organization (WTO) principles in the Technical Barriers to Trade (TBT) see the following URL: [www.iso.org/iso/foreword.html](http://www.iso.org/iso/foreword.html)

The committee responsible for this document is ISO/TC 39 *Machine tools*, Subcommittee SC 2 *Test conditions for metal cutting machine tools*.

This fourth edition cancels and replaces the third edition (ISO 3070-2:2007), which has been technically revised.

ISO 3070 consists of the following parts under the general title *Machine tools — Test conditions for testing the accuracy of boring and milling machines with horizontal spindle*:

- *Part 1: Machines with fixed column and table movable on a cross slide*
- *Part 2: Machines with movable column along the X-axis (floor type)*
- *Part 3: Machines with movable column along the Z-axis (T-bed type)*

## Introduction

Most horizontal spindle boring and milling machines fall into the following three categories characterized by their particular configuration:

- a) machines with fixed column and table movable on a cross slide;
- b) machines with movable column along the X-axis (floor type);
- c) machines with movable column along the Z-axis (T-bed type).

The object of ISO 3070 is to supply information as wide and comprehensive as possible on tests which can be carried out for comparison, acceptance, maintenance or any other purpose.

This revision of this part of ISO 3070 provides additional information on tests to be performed and specifies new tolerances to better reflect the current technology.

Machining tests have been excluded from this revision of this part of ISO 3070 considering that such tests can typically be the object of agreement between manufacturer/supplier and user, (possibly) including tests that are specified in ISO 10791-7.





# Machine tools — Test conditions for testing the accuracy of boring and milling machines with horizontal spindle —

## Part 2:

## Machines with movable column along the X-axis (floor type)

### 1 Scope

This part of ISO 3070 specifies, with reference to ISO 230-1, ISO 230-7 and ISO 230-2, geometric tests, spindle tests and tests for checking the accuracy and repeatability of positioning by numerical control of horizontal spindle boring and milling machines having a movable column along the X-axis and also specifies the applicable tolerances corresponding to general-purpose, normal accuracy machines.

This type of machines are usually provided with sliding boring spindles and can be provided with universal spindle heads of the following types, whose test conditions are covered by ISO 17543-1:

- fixed or indexable heads, with accessory spindle(s) square to the Z-axis, with or without one spindle parallel to the Z-axis;
- 45° split indexable heads, with mechanical indexing of the different angular positions of the two bodies (e.g. Hirth couplings);
- 45° split continuous heads, provided with continuous positioning of the two numerically controlled axes;
- swivel heads, with two numerically controlled rotary axes perpendicular to each other.

Test conditions for accessory facing heads are specified in [Annex B](#).

This part of ISO 3070 concerns machines having movement of the column on the bed (X-axis), vertical movement of the spindle head on the column (Y-axis), axial movement of the ram (Z-axis), axial movement of the boring spindle (W-axis), and, in most cases, one or more tables moving on a bed parallel to the spindle (R-axis) and rotating around a vertical axis (B-axis).

This part of ISO 3070 deals only with the verification of the accuracy of the machine. It does not apply to the operational testing of the machine (e.g. vibration, abnormal noise, stick-slip motion of components) nor to machine characteristics (e.g. speeds, feeds), as such checks are generally carried out before testing the accuracy.

### 2 Normative references

The following documents, in whole or in part, are normatively referenced in this document and are indispensable for its application. For dated references, only the edition cited applies. For undated references, the latest edition of the referenced document (including any amendments) applies.

ISO 230-1:2012, *Test code for machine tools — Part 1: Geometric accuracy of machines operating under no-load or quasi-static conditions*

ISO 230-2:2014, *Test code for machine tools — Part 2: Determination of accuracy and repeatability of positioning of numerically controlled axes*

ISO 230-7:2015, *Test code for machine tools — Part 7: Geometric accuracy of axes of rotation*

### 3 Terms and definitions

For the purposes of this document, the following terms and definitions apply.

#### 3.1 boring operation

machining operation for generating holes of various sizes and geometries in which the principal cutting motion is the rotation of a single-point cutting tool against the non-rotating workpiece and where the cutting energy is brought by the cutting tool rotation

Note 1 to entry: Boring the diameter of cylindrical, conical, blind or through holes to the required size is achieved by using a boring bar to locate the cutting edge of the boring tool in a well-defined position with respect to the axis average line of the boring spindle.

Note 2 to entry: In the case of coaxial bores situated on opposite faces of the same workpiece, the operation may be carried out using the sliding boring spindle, if it can work through all the workpiece, or turning the table 180° to bore the opposite side of the workpiece (reverse boring).

#### 3.2 milling operation

machining operation to generate surfaces of various geometries in which the principal cutting motion is the rotation of a cutting tool with multiple cutting edges against the non-rotating workpiece and where the cutting energy is brought by the cutting tool rotation

Note 1 to entry: Milling operations mostly involve face milling or end milling. The tools are mounted either in the boring spindle taper (see [Figure 2](#)) or, as for face milling cutters, on the milling spindle nose.

#### 3.3 boring and milling machine

machine tool in which boring and milling operations are executed

### 4 Terminology and designation of axes

In a boring and milling machine, cutting movement is generated by the rotation of the spindle(s) and, possibly, of the facing head.

The feed movements are as follows:

- a) transverse movements of the column on the bed (X-axis);
- b) vertical movement of the spindle head (Y-axis);
- c) axial movement of the ram (Z-axis);
- d) axial movement of the spindle (W-axis);
- e) axial movement of the table (R'-axis), where available;
- f) possible (optional) movement of radial facing slide (U-axis);
- g) possible (optional) movement of the rotary table (B'-axis).

[Figure 1](#) shows two typical configurations of such machines.

The designation of the configuration with fixed table is: w b X Y Z W (C) t whereas the designation of the configuration with roto-translating table is: w B' R' b X Y Z W (C) t.

NOTE The foundation is very important for these machine tool configurations. The designation "b" for these machines typically includes the bed on the workpiece side, the foundation, and the bed on the tool side.

[Table 1](#) provides the nomenclature for various structural components of machines shown in [Figure 1](#).

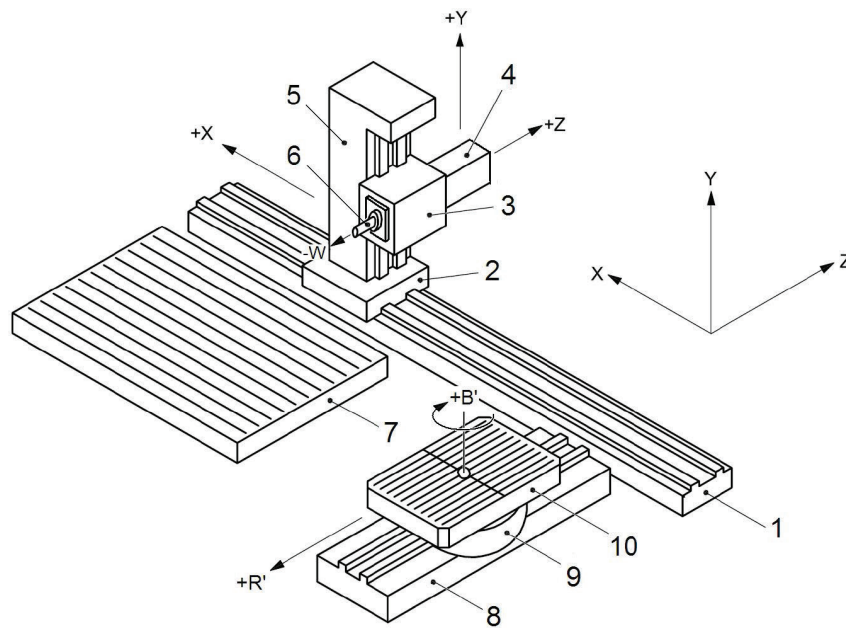

NOTE For elements 1 to 10, see [Table 1](#).

**Figure 1 — Machine with movable column along the X-axis with (optional) roto-translating table**

**Table 1 — Nomenclature (see [Figure 1](#))**

| <a href="#">Figure 1</a><br>ref. | English             | French                        | Russian                   |
|----------------------------------|---------------------|-------------------------------|---------------------------|
| 1                                | bed                 | banc                          | станина                   |
| 2                                | column base         | base du montant               | основание стойки          |
| 3                                | spindle head        | chariot porte-broche          | шпиндельная бабка         |
| 4                                | ram                 | coulant                       | подвижный корпус шпинделя |
| 5                                | column              | montant                       | стойка                    |
| 6                                | spindle             | broche                        | шпиндель                  |
| 7                                | fixed table         | table fixe                    | неподвижный стол          |
| 8                                | table bed           | banc de la table              | основание стола           |
| 9                                | rotary table saddle | traînard de la table rotative | каретка поворотного стола |
| 10                               | rotary table        | table rotative                | поворотный стол           |

NOTE In addition to the terms used in the three ISO official languages, presented in this table, [Table C.1](#) provides the equivalent terms in Italian and Persian; these are published under the responsibility of the member body for Italy (UNI) and Iran (ISIRI) and are given for information only. Only the terms given in the official languages can be considered as ISO terms.

## 5 Special remarks concerning particular elements

### 5.1 Spindle heads

Reference should be made to [Figure 2](#) for examples of the various types of head. Related nomenclature is given in [Table 2](#).

Facing heads generally have a radial facing slide and in most cases are accessories. Relevant geometric tests are specified in [Annex B](#).

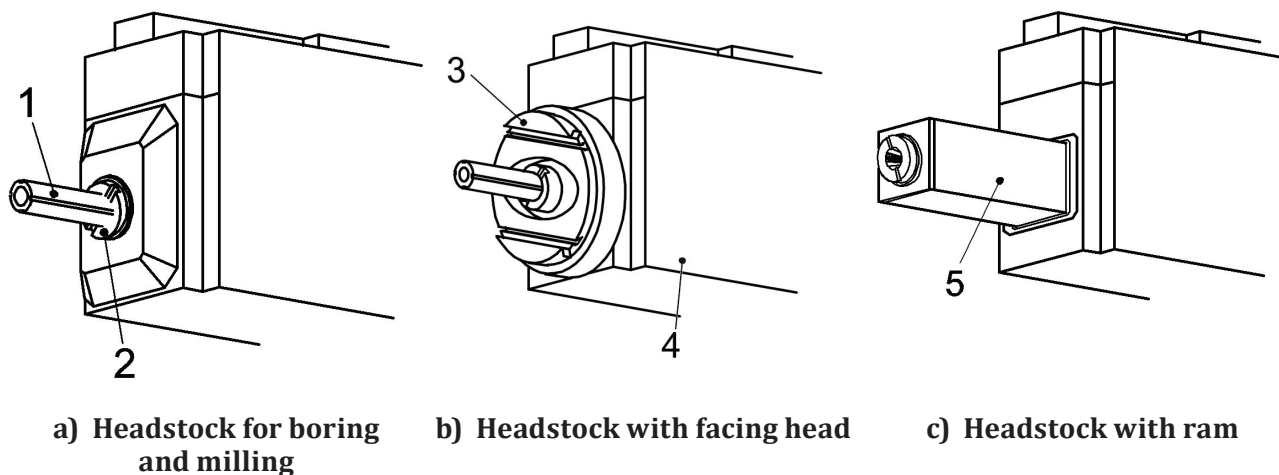

NOTE For elements 1 to 5, see [Table 2](#).

Figure 2 — Types of headstocks

Table 2 — Nomenclature (see [Figure 2](#))

| Figure 2 ref. | English                    | French                         | Russian                        |
|---------------|----------------------------|--------------------------------|--------------------------------|
| 1             | boring spindle             | broche d'alésage               | расточный шпиндель             |
| 2             | milling spindle            | broche de fraisage             | фрезерный шпиндель             |
| 3             | facing head                | plateau à surfacer             | планшайба                      |
| 4             | headstock with facing head | bélier avec plateau à surfacer | шпиндельная бабка с планшайбой |
| 5             | ram                        | coulant                        | подвижный корпус шпинделя      |

NOTE In addition to the terms used in the three ISO official languages, given in this table, [Table C.2](#) provides the equivalent terms in Italian and Persian; these are published under the responsibility of the member body for Italy (UNI) and Iran (ISIRI) and are given for information only. Only the terms given in the official languages can be considered as ISO terms.

## 5.2 Tables

In most cases, this type of machines is provided with both fixed tables and movable tables with linear and rotary movements.

The rotary movement of the table may be used for the following purposes:

- a) angular positioning of the workpiece;
- b) as a circular work feed for milling operations;
- c) circular cutting movements for turning operations.

## 6 Preliminary remarks

### 6.1 Measurement units

In this part of ISO 3070, all linear dimensions and deviations are expressed in millimetres. All angular dimensions are expressed in degrees. Angular deviations are, in principle, expressed in ratios but in some cases, microradians or arcseconds may be used for clarification purposes. The following expression should be used for the conversion of the units of angular deviations or tolerances:

$$0,010/1\ 000 = 10\ \mu\text{rad} \approx 2''$$

### 6.2 Reference to ISO 230 series of standards

In applying this part of ISO 3070, reference shall be made to ISO 230-1, especially for the installation of the machine before testing, warming up of the spindle and other moving components, description of the measuring methods and recommended accuracy of the test equipment.

No tests related to checking thermal effects, based on ISO 230-3, are included in this part of ISO 3070. If such tests are of interest, relevant tests in ISO 10791-10 shall be referred to.

In the “Observations” block of the tests described in the following subclauses, the instructions are preceded by a reference to the corresponding clause or subclause in ISO 230-1, ISO 230-2 or ISO 230-7 in cases where the test concerned is in compliance with the specifications of one or another of those parts of ISO 230.

### 6.3 Testing sequence

The sequence in which the tests are presented in this part of ISO 3070 in no way defines the practical order of testing. In order to make the mounting of instruments or gauging easier, tests may be performed in any order.

It is nevertheless recalled that angular deviations affect straightness measurements; therefore, best practice would suggest to perform tests related to angular error motions prior to straightness measurements.

### 6.4 Tests to be performed

When testing a machine, it is not always necessary or possible to carry out all the tests described in this part of ISO 3070. When the tests are required for acceptance purposes, it is up to the user to choose, in agreement with the supplier/manufacturer, those tests relating to the components and/or the properties of the machine which are of interest. ISO 230-1:2012, Annex A provides valuable information about selection of primary and secondary axes and associated tests. These tests are to be clearly stated when ordering a machine. The mere reference to this part of ISO 3070 for the acceptance tests, without specifying the tests to be carried out or without agreement on the relevant expenses, cannot be considered as binding for any contracting party.

### 6.5 Measuring instruments

Measuring instruments indicated in the tests described in the following subclauses are examples only. Other instruments capable of measuring the same quantities and having the same, or a smaller, measurement uncertainty can be used. Reference shall be made to ISO 230-1:2012, Clause 5, which indicates the relationship between measurement uncertainties and the tolerances.

When a “dial gauge” is referred to, it can mean not only dial test indicators (DTI), but any type of linear displacement sensor such as analogue or digital dial gauges, linear variable differential

transformer (LVDTs), linear scale displacement gauges, or non-contact sensors, when applicable to the test concerned (see ISO 230-1:2012, Clause 4).

Similarly, when a “straightedge” is referred to, it can mean any type of straightness reference artefact, such as a granite or ceramic or steel or cast iron straightedge, one arm of a square, one generating line on a cylinder square, any straight path on a reference cube, or a special, dedicated artefact manufactured to fit in the T-slots or other references.

In the same way, when a “square” is mentioned, it can mean any type of squareness reference artefact, such as a granite or ceramic or steel or cast iron square, a cylinder square, a reference cube, or, again, a special, dedicated artefact.

When “3D probe” is referred to, it means three displacement sensors, housed in a nest, used to measure the changes in the position of the centre of a precision sphere; when the nest and the sphere are moved together along a programmed tool path.

## **6.6 Software compensation**

When built-in software facilities are available for compensating geometric, positioning, contouring and thermal deviations, their use during these tests should be based on agreement between manufacturer/supplier and user, with due consideration to the machine tool intended use, e.g. if the intended use of the machine tool is with or without software compensation for geometric errors. When the software compensation is used, this shall be stated in the test report.

It shall be noted that when software compensation is used, some machine tool axes cannot be locked for test purposes.

Valuable information on numerical compensation of geometric errors can be gathered in ISO/TR 16907.

## **6.7 Minimum tolerance**

By mutual agreement, manufacturer/supplier and user can establish the tolerance for a measuring length different from that given in the tests described in the following clauses. However, it shall be considered that the minimum value of tolerance is 0,005 mm.

## 7 Geometric tests

### 7.1 Straightness and angular deviations of linear axes

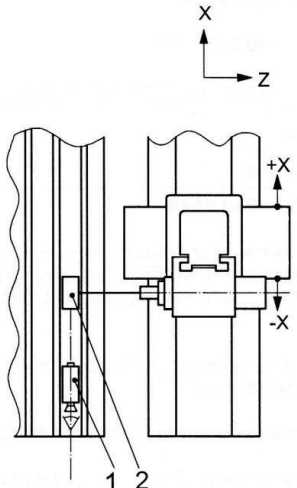
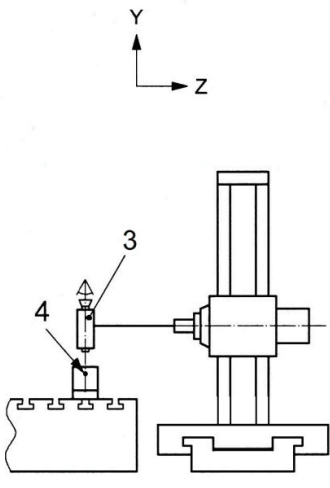
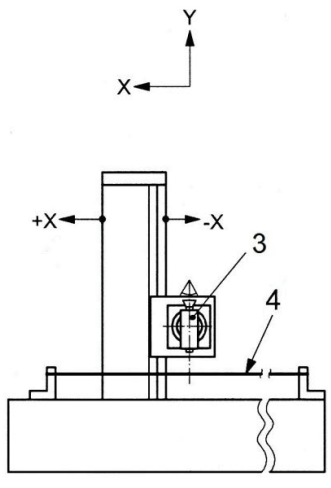
| Object  |       |  |        |  | G1 |
|---|-------|--|--------|--|----|
| Checking of the straightness of the column movement (X-axis):   |       |  |        |  |    |
| a) in the vertical XY plane, $E_{YX}$ ;   |       |  |        |  |    |
| b) in the horizontal ZX plane, $E_{ZX}$ .   |       |  |        |  |    |
| Diagram   |       |  |        |  |    |
|  <p>for a) and b)</p>   |       |  <p>for b) only</p> |        |  |    |
| Key   |       |  |        |  |    |
| 1 alignment telescope   |       |  |        |  |    |
| 2 telescope target  |       |  |        |  |    |
| 3 microscope  |       |  |        |  |    |
| 4 taut wire   |       |  |        |  |    |
| Tolerance   |       |  |        | Measured deviations  |    |
| for measuring length up to:   |       |  |        |  |    |
|   | 5 000 | 10 000   | 15 000 | 20 000   |    |
| for a)  | 0,07  | 0,14   | 0,21   | 0,29   | a) |
| for b)  | 0,06  | 0,11   | 0,16   | 0,21   | b) |
| For measuring lengths over 20 000, the tolerance shall be agreed upon between manufacturer/supplier and user.   |       |  |        |  |    |
| Measuring instruments   |       |  |        |  |    |
| Optical methods and, for b) only, microscope and taut wire.   |       |  |        |  |    |
| Observations and references to ISO 230-1:2012, 8.2.2.1 and 8.2.2.3  |       |  |        |  |    |
| a) Taut wire is not recommended because of the sag of the wire. The alignment telescope may be fixed on the work-holding table such that the optical beam is parallel to the X-axis movement of the column or the lack of parallelism shall be considered in the measurement. |       |  |        |  |    |
| If the spindle can be locked, the telescope target may be mounted on it. If the spindle cannot be locked, mount the telescope target on the spindle head.   |       |  |        |  |    |
| b) The microscope shall be fixed on the spindle, if it can be locked, or on the spindle head.   |       |  |        |  |    |
| For a) and b): Measurements shall be carried out on at least six positions along the travel, with equally spaced steps not exceeding 500.   |       |  |        |  |    |
| Measurements shall be at mid travel of the ram travel with the spindle retracted or otherwise, measurement location shall be reported.  |       |  |        |  |    |

|   |  |                            |
|---|--|----------------------------|
| <b>Object</b>   |  | <b>G2</b>                  |
| Checking of the angular deviation of the column movement (X-axis):<br>a) in the XY plane, $E_{CX}$ (pitch);<br>b) in the YZ plane, $E_{AX}$ (roll);<br>c) in the ZX plane, $E_{BX}$ (yaw).  |  |                            |
| <b>Diagram</b>  |  |                            |
| <p style="text-align: center;">a) and b) <span style="margin-left: 200px;">c)</span></p>  |  |                            |
| <b>Key</b>  |  |                            |
| 1 reference levels<br>2 measuring levels<br>3 mirror<br>4 auto-collimator   |  |                            |
| <b>Tolerance</b>  | for a), b) and c):<br>$X \leq 4\,000$ : 0,04/1 000<br>$X > 4\,000$ : 0,06/1 000<br>Local tolerance: 0,02/1 000 for any measuring length of 500 | <b>Measured deviations</b> |
|   |  | a)<br>b)<br>c)             |
| <b>Measuring instruments</b>  |  |                            |
| a) Precision level, laser interferometer or other optical angular deviation measuring instruments.<br>b) Precision level.<br>c) Laser interferometer or other optical angular deviation measuring instruments.  |  |                            |
| <b>Observations and references to ISO 230-1:2012, 3.4.16 and 8.4</b>  |  |                            |
| The measuring level or the mirror shall be placed on the ram.<br>a) $E_{CX}$ (pitch) in the X-axis direction (with optical instruments set vertically).<br>b) $E_{AX}$ (roll) in the Z-axis direction.<br>c) $E_{BX}$ (yaw) with optical instruments set horizontally.<br>When levels are used, a reference level shall be located on the fixed table and the ram shall be in the middle of the travel range (Z-axis). Several preliminary movements of the column should be carried out with the reference level in different positions on the fixed table in order to check whether the X-axis motion causes an angular movement of any part of the fixed table or the bed(s) of the rotary table(s). In this last case, differential measurements of the two angular movements shall be made and this shall be stated.<br>For a), b) and c): Measurements shall be carried out on at least six positions along the travel, with equally spaced steps not exceeding 500.<br>Measurement location shall be reported. |  |                            |

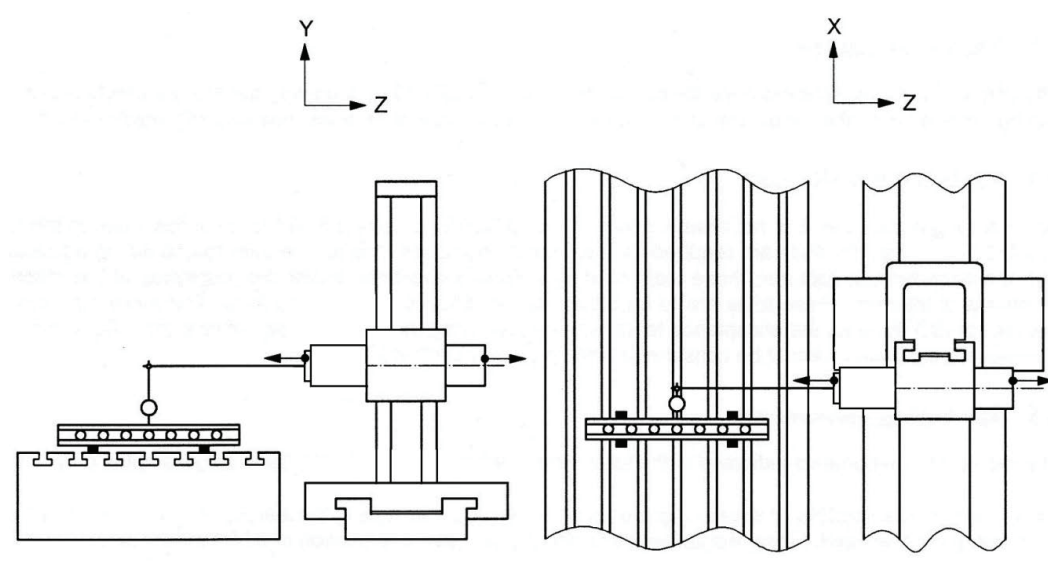

| <b>Object</b>   |  | <b>G3</b> |       |       |      |      |      |  |
|---|--|-----------|-------|-------|------|------|------|--|
| Checking of the straightness of the ram movement (Z-axis):<br>a) in the vertical YZ plane, $E_{YZ}$ ;<br>b) in the horizontal ZX-plane, $E_{XZ}$ .  |  |           |       |       |      |      |      |  |
| <b>Diagram</b><br> <p>The diagram illustrates two measurement configurations. Configuration (a) is for the vertical YZ plane, showing a dial gauge mounted on a vertical spindle that moves along the Z-axis. Configuration (b) is for the horizontal ZX-plane, showing a dial gauge mounted on a horizontal spindle that moves along the Z-axis. Both configurations include a straightedge on the table and a dial gauge mounted on the ram face. Coordinate systems are shown above each setup: (Y, Z) for (a) and (X, Z) for (b).</p>  |  |           |       |       |      |      |      |  |
| <b>Tolerance</b><br><br>for a) and b):  | for measuring lengths up to:<br><table border="1"> <tr> <td>1 000</td> <td>1 500</td> <td>2 000</td> </tr> <tr> <td>0,02</td> <td>0,03</td> <td>0,04</td> </tr> </table> | 1 000     | 1 500 | 2 000 | 0,02 | 0,03 | 0,04 | <b>Measured deviations</b><br>a)<br>b) |
| 1 000   | 1 500  | 2 000     |       |       |      |      |      |  |
| 0,02  | 0,03   | 0,04      |       |       |      |      |      |  |
| Local tolerance: 0,006 for any measuring length of 300.<br>For measuring lengths over 2 000, the tolerance shall be agreed upon between manufacturer/supplier and user.   |  |           |       |       |      |      |      |  |
| <b>Measuring instruments</b><br>Dial gauge and straightedge with gauge blocks or optical methods.   |  |           |       |       |      |      |      |  |
| <b>Observations and references to ISO 230-1:2012, 8.2.2.1 and 8.2.2.3</b><br>Set a straightedge on the table, parallel to the ram movement (Z-axis) for a) vertically and b) horizontally, or the lack of parallelism shall be considered in the measurement.<br>If the spindle can be locked, the dial gauge may be mounted on it. If the spindle cannot be locked, the dial gauge shall be mounted on the ram face. The stylus shall be normal to the reference face of the straightedge.<br>Measurements shall be carried out on at least six positions along the travel, in both direction of motion, with equally spaced steps not exceeding 300.<br>Measurement location shall be reported. |  |           |       |       |      |      |      |  |

**Object** G4

Checking of the angular deviation of the ram movement (Z-axis):

- a) in the vertical YZ plane,  $E_{AZ}$  (pitch);
- b) in the vertical XY plane,  $E_{CZ}$  (roll);
- c) in the horizontal ZX plane,  $E_{BZ}$  (yaw).

**Diagram**

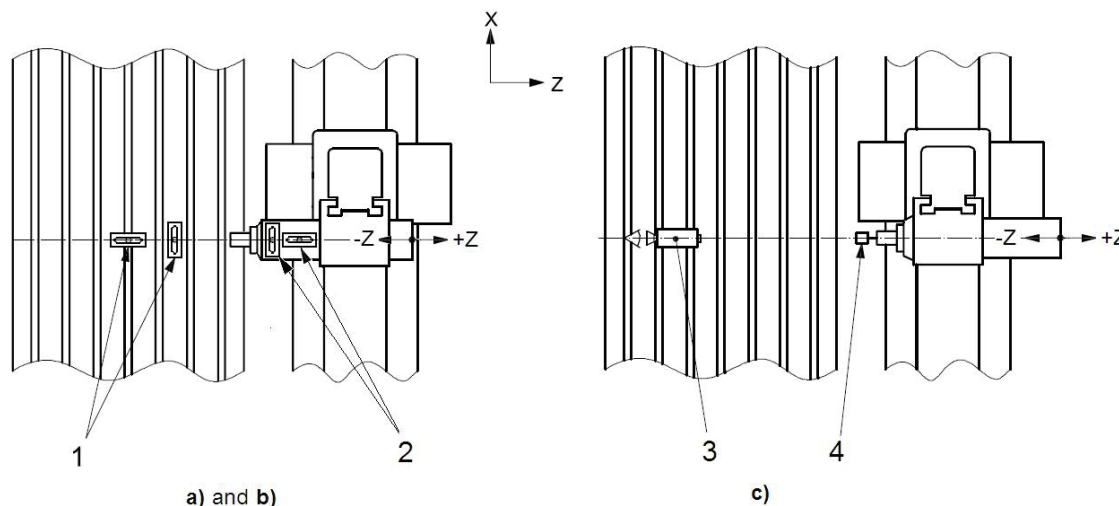

**Key**

- 1 reference levels
- 2 measuring levels
- 3 auto-collimator
- 4 mirror

| Tolerance  | for measuring lengths up to: |            |            | Measured deviations |
|--|------------------------------|------------|------------|---------------------|
|  | 1 000                        | 1 500      | 2 000      |                     |
| for a), $E_{AZ}$ :   | 0,06/1 000                   | 0,08/1 000 | 0,10/1 000 | a)                  |
| for b), $E_{CZ}$ and c), $E_{BZ}$ :  | 0,04/1 000                   | 0,05/1 000 | 0,06/1 000 | b)                  |
| For measuring lengths over 2 000, the tolerance shall be agreed upon between manufacturer/supplier and user. |                              |            |            |                     |

**Measuring instruments**

- a) Precision level, laser interferometer or other optical angular deviation measuring instruments.
- b) Precision level.
- c) Laser interferometers or other optical angular deviation measuring instruments.

**Observations and references to ISO 230-1:2012, 3.4.16 and 8.4**

The measuring level shall be placed on the ram, the mirror shall be placed on the ram face:

- a)  $E_{AZ}$ , in the Z-axis direction (with optical instruments set vertically);
- b)  $E_{CZ}$ , in the X-axis direction;
- c)  $E_{BZ}$ , with optical instruments set horizontally.

When levels are used, a reference level shall be located on the fixed table (or on the rotary table), to check that the Z-axis motion does not cause an angular movement of any fixed component on the workpiece side. If angular movements are detected, differential measurements shall be carried out and this shall be stated.

For a), b) and c): Measurements shall be carried out on at least six positions along the travel, with equally spaced steps.

**Object** G5

Checking of the straightness of the spindle head movement (Y-axis):

- a) in the vertical YZ plane parallel to spindle axis,  $E_{ZY}$ ;
- b) in the vertical XY plane square to the spindle axis,  $E_{XY}$ .

**Diagram**

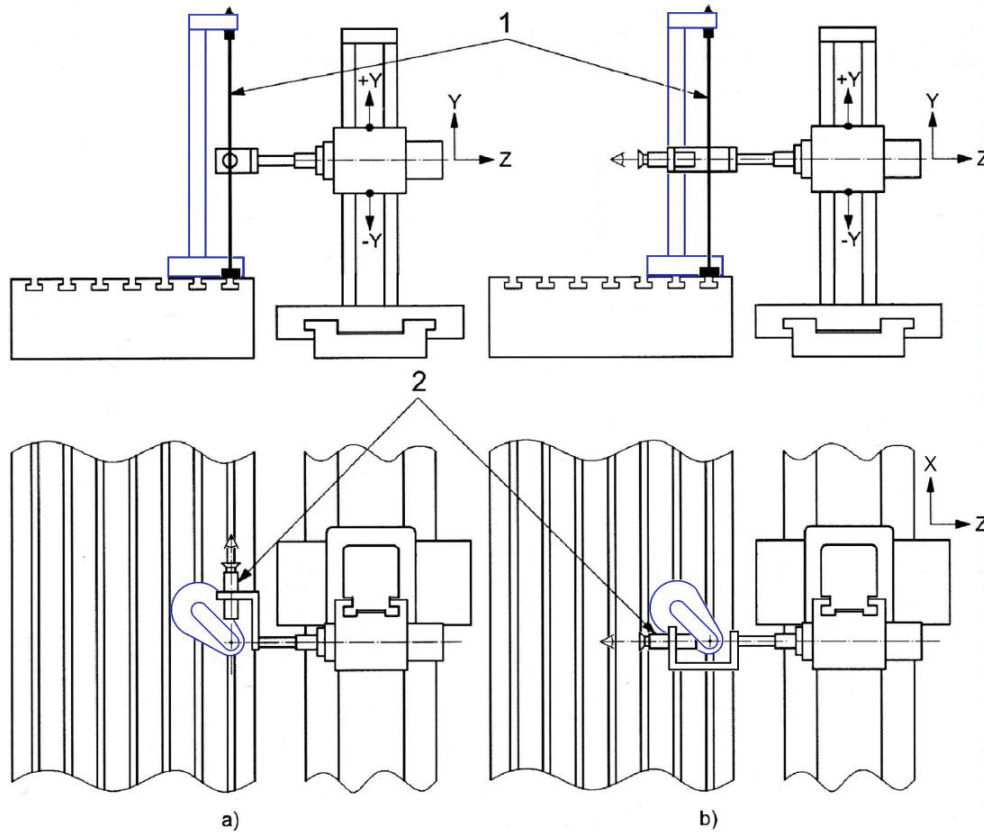

**Key**

- 1 taut wire
- 2 microscope

| Tolerance      | for measuring lengths up to: |       |       |       |       | Measured deviations |
|----------------|------------------------------|-------|-------|-------|-------|---------------------|
|                | 2 000                        | 3 000 | 4 000 | 5 000 | 6 000 |                     |
| for a) and b): | 0,03                         | 0,04  | 0,05  | 0,07  | 0,09  | a)<br>b)            |

For measuring lengths over 6 000, the tolerance shall be agreed upon between manufacturer/supplier and user.

**Measuring instruments**

Microscope and taut wire or optical methods.

**Observations and references to ISO 230-1:2012, 8.3, 8.2.2.2 or 8.2.2.3**

The ram (Z-axis) shall be at mid travel with the spindle retracted.

The taut wire shall be tightened between the fixed table and another fixed part independent from the machine column.

If the spindle can be locked, the microscope or the target of the alignment telescope may be mounted on it. If the spindle cannot be locked, the microscope or the target shall be placed on the ram face.

Measurement location shall be reported.

|  |           |
|--|-----------|
| <b>Object</b>  | <b>G6</b> |
| Checking of the angular deviations of the spindle head movement (Y-axis):<br>a) in the vertical YZ plane parallel to the spindle axis, $E_{AY}$ ;<br>b) in the vertical XY plane square to the spindle axis, $E_{CY}$ ;<br>c) in the horizontal ZX plane, $E_{BY}$ (roll). |           |

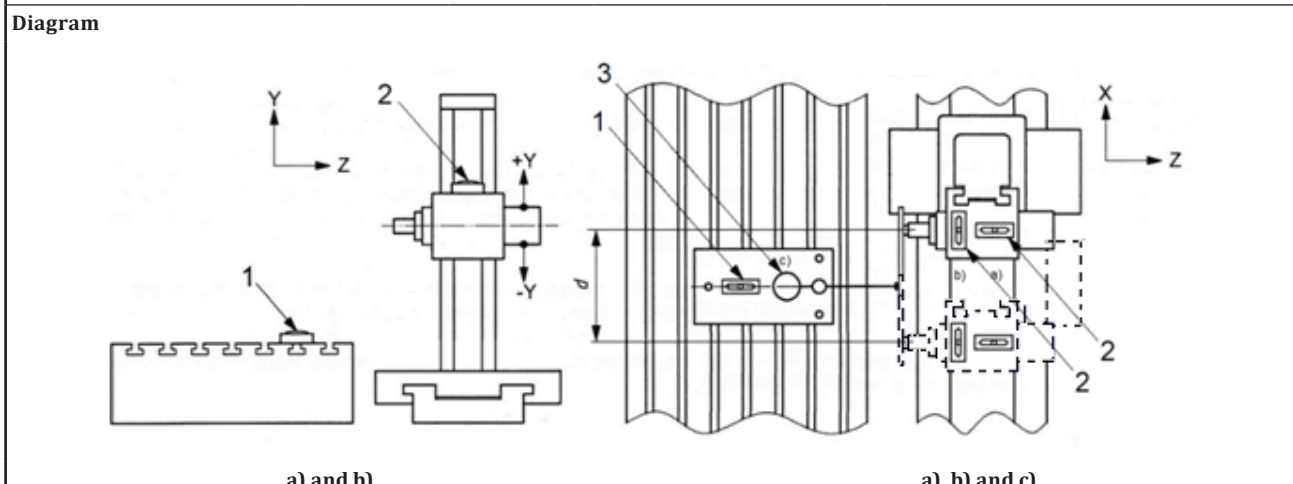

**Key**  
 1 reference level  
 2 measuring level  
 3 cylinder square  
 d measurement distance

| Tolerance | for measuring lengths up to: |            |            |            |            | Measured deviations |
|-----------|------------------------------|------------|------------|------------|------------|---------------------|
|           | 2 000                        | 3 000      | 4 000      | 5 000      | 6 000      |                     |
|           | 0,04/1 000                   | 0,04/1 000 | 0,04/1 000 | 0,05/1 000 | 0,06/1 000 | a)                  |
|           |                              |            |            |            |            | b)                  |
|           |                              |            |            |            |            | c)                  |

For measuring lengths over 6 000, the tolerance shall be agreed upon between manufacturer/supplier and user.

**Measuring instruments**  
 For a) and b): Precision level or optical angular deviation measuring instruments.  
 For c): Surface plate, cylindrical square, level and dial gauge or taut wire and microscope or sweeping alignment laser.

**Observations and references to ISO 230-1:2012, 3.4.16 and 8.4**  
 For a), b) and c): Measurements shall be carried out on at least six positions along the travel, with equally spaced steps not exceeding 500.  
 For a) and b): Place a level on the spindle head in the Z-axis direction for a) and in the X-axis direction for b). The reference level shall be located on the work holding table in the same direction of the measuring level with a view to checking that the Y-axis motion does not cause an angular movement of any fixed component on the workpiece side. Some preliminary movements of the Y-axis should be carried out with both levels, in order to check whether the Y-axis motion causes an angular movement of any part of the fixed table or the bed(s) of the rotary table(s). In this last case, differential measurements of the two angular movements shall be made and this shall be stated.  
 For c): Measure the  $E_{ZY}$  straightness deviation of the Y-axis by an instrument placed on a special arm with a horizontal offset  $d$  from the spindle axis: c 1) by a dial gauge against a cylindrical square standing on a levelled surface plate. c 2) by a microscope targeting a vertical taut wire or c 3) by a target of a sweeping alignment laser which is generating an optical XY plane. Note the readings and the relevant measuring positions on the spindle head travel (Y-axis). Turn the special arm (carrying the instrument) to the opposite side of the spindle and move the X-axis of about  $2d$  in order to repeat the same readings against the same reference; the possible roll deviations of the X-axis motion shall be measured and taken into account. For c3), no X-axis movement is required. The instrument shall be reset and the new measurements shall be taken at the same heights of the previous ones and then noted. For each measurement position, calculate the algebraic difference between the two readings and then calculate the difference between maximum and minimum divided by the distance  $2d$  for obtaining the angular deviation.  
 NOTE For machine tools not compensated by software, Y-axis roll can also be measured performing two  $E_{XY}$  measurements with a Z-axis offset.

## 7.2 Squareness and parallelism between linear axes

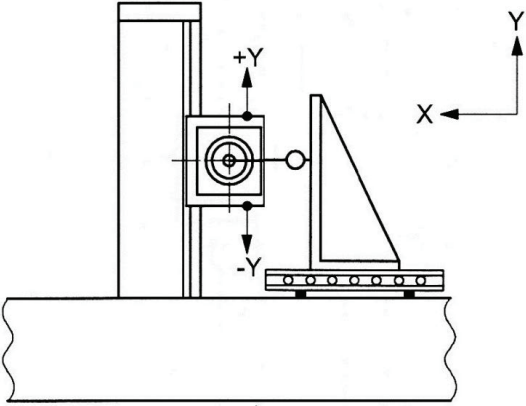
|   |                            |
|---|----------------------------|
| <b>Object</b>   | <b>G7</b>                  |
| Checking of the squareness between the spindle head movement (Y-axis) and the column movement (X-axis), $E_{C(0X)Y}$ .  |                            |
| <b>Diagram</b>    |                            |
| <b>Tolerance</b>  | <b>Measured deviations</b> |
| 0,04/1 000  |                            |
| <b>Measuring instruments</b>  |                            |
| Square, straightedge, adjustable blocks and dial gauge.   |                            |
| <b>Observations and references to ISO 230-1:2012, 10.3.2</b><br><p>Set a straightedge on the table parallel to the column movement (X-axis) using adjustable blocks or the lack of parallelism shall be considered in the measurement, and then place a square on it.</p> <p>If the spindle can be locked, the dial gauge may be mounted on it. If the spindle cannot be locked, the dial gauge shall be placed on the ram face.</p> <p>Apply the stylus of the dial gauge to the square, measuring in the X-direction. Position the Y-axis to measure close to one end of the square surface and zero the dial gauge.</p> <p>Move the Y-axis to measure close to the other end of the square surface and note the reading. The measured squareness error, <math>E_{C(0X)Y}</math>, is the ratio between the reading and the travelled distance along the Y-axis.</p> |                            |

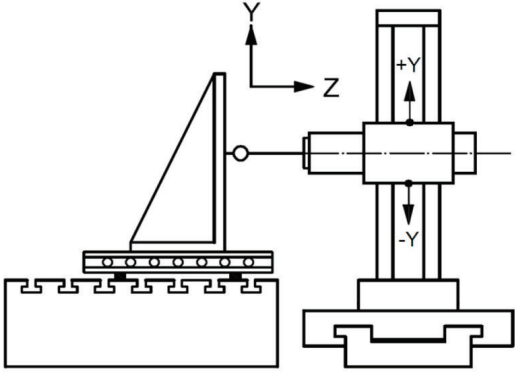
|   |                           |
|---|---------------------------|
| <b>Object</b>   | <b>G8</b>                 |
| Checking of the squareness between the spindle head movement (Y-axis) and the ram movement (Z-axis), $E_{A(0Z)Y}$ or $E_{A(0Y)Z}$ .   |                           |
| <b>Diagram</b><br>   |                           |
| <b>Tolerance</b><br><p style="text-align: center;">0,06/1 000</p>   | <b>Measured deviation</b> |
| <b>Measuring instruments</b><br>Square, straightedge, adjustable blocks and dial gauge.   |                           |
| <b>Observations and references to ISO 230-1:2012, 10.3.2</b><br><p>Set a straightedge on the table parallel to the ram movement (Z-axis) using adjustable blocks or the lack of parallelism shall be considered in the measurement and then place a square on it.</p> <p>If the spindle can be locked, the dial gauge may be mounted on it. If the spindle cannot be locked, the dial gauge shall be placed on the ram face.</p> <p>Apply the stylus of the dial gauge to the square, measuring in the Z-direction. Position the Y-axis to measure close to one end of the square surface and zero the dial gauge.</p> <p>Move the Y-axis to measure close to the other end of the square surface and note the reading.</p> <p>The measured squareness error, <math>E_{A(0Z)Y}</math>, is the ratio between the reading and the travelled distance along the Y-axis.</p> <p>Or, alternatively:</p> <p>Align the straightedge so that the vertical arm of a square laid on this straightedge is parallel to the spindle head movement (Y-axis) or the lack of parallelism shall be considered in the measurement.</p> <p>Apply the stylus of the dial gauge to the straightedge, measuring in the Y-direction. Retract the Z-axis and zero the dial gauge.</p> <p>Move the Z-axis of the desired distance and note the reading.</p> <p>The measured squareness error, <math>E_{A(0Y)Z}</math>, is the ratio between the reading and the travelled distance along the Z-axis.</p> |                           |

|   |                           |
|---|---------------------------|
| <b>Object</b>   | <b>G9</b>                 |
| Checking of the squareness between the ram movement (Z-axis) and the column movement (X-axis), $E_{B(0X)Z}$ .   |                           |
| <b>Diagram</b>  |                           |
|   |                           |
| <b>Tolerance</b>  | <b>Measured deviation</b> |
| 0,06/1 000  |                           |
| <b>Measuring instruments</b>  |                           |
| Square and dial gauge.  |                           |
| <b>Observations and references to ISO 230-1:2012, 10.3.2</b>  |                           |
| Set a square on the table and align one side parallel to the column movement (X-axis) or the lack of parallelism shall be considered in the measurement.  |                           |
| If the spindle can be locked, the dial gauge may be mounted on it. If the spindle cannot be locked, the dial gauge shall be placed on the ram face.   |                           |
| Apply the stylus of the dial gauge to the square, measuring in the X-direction. Position the Z-axis to measure close to one end of the square surface and zero the dial gauge.  |                           |
| Move the Z-axis to measure close to the other end of the square surface and note the reading. The measured squareness error, $E_{B(0X)Z}$ , is the ratio between the reading and the travelled distance along the Z-axis. |                           |

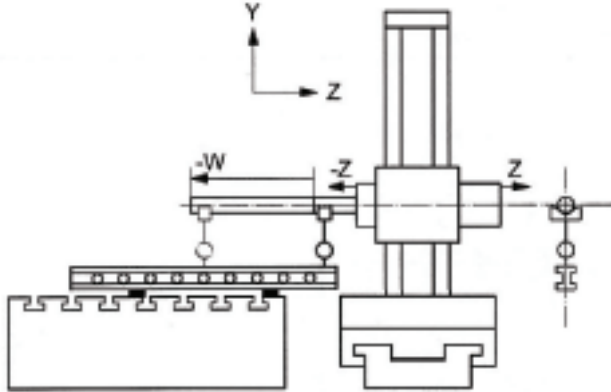
|   |   |
|---|---|
| <b>Object</b>   | <b>G10a</b>   |
| Checking of the parallelism between the boring spindle axial movement (W-axis) and the ram movement (Z-axis), $E_{A(0Z)W}$ in the YZ plane.   |   |
| <b>Diagram</b><br>  |   |
| <b>Tolerance</b><br>For an extension of the spindle equal to the following:<br>$2D$ : +0,015 (upwards);<br>$4D$ : $\pm 0,02$ ;<br>$6D$ : -0,06 (downwards).<br>where $D$ is the diameter of the boring spindle.<br>The extension of the spindle is limited to six times the spindle diameter and shall not exceed 900.<br>The tolerance is limited to spindle diameter of 150. When the spindle diameter is over 150, the tolerance shall be agreed upon between the manufacturer/supplier and the user.  | <b>Measured deviation</b><br>a)<br>or, alternatively:<br>b) |
| <b>Measuring instruments</b><br>Straightedge, adjustable blocks and dial gauge.   |   |
| <b>Observations and references to ISO 230-1:2012, 12.3.2.3 and 10.3.2</b><br>Place a straightedge on the table vertically in a plane containing the spindle axis and adjust it parallel to the ram movement (Z-axis), or the lack of parallelism shall be considered in the measurement.<br>The spindle rotation shall be locked. Touch the surface of the straightedge with the dial gauge stylus and zero it. Extend the boring spindle (W-axis) to the required length and record the dial gauge reading. The measured parallelism error, $E_{A(0Z)W}$ , is the ratio between the reading and the travelled distance along the W-axis. |   |

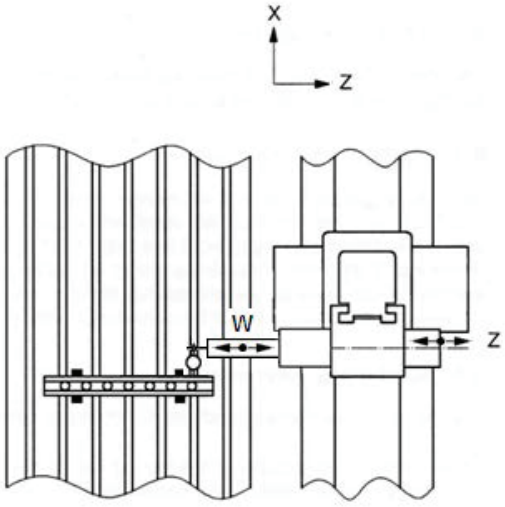

|  |                           |            |
|--|---------------------------|------------|
| <b>Object</b>  | <b>G10b</b>               |            |
| Checking of the parallelism between the boring spindle axial movement ( $W$ -axis) and the ram movement ( $Z$ -axis), $E_{B(0Z)W}$ , in the $ZX$ plane.  |                           |            |
| <b>Diagram</b><br><br>   |                           |            |
| <b>Tolerance</b>   | <b>Measured deviation</b> | 0,04/1 000 |
| <b>Measuring instruments</b><br>Straightedge and dial gauge.   |                           |            |
| <b>Observations and references to ISO 230-1:2012, 12.3.2.3 and 10.3.2</b><br><p>Place a straightedge on the table horizontally and adjust it parallel to the ram movement (<math>Z</math>-axis) or the lack of parallelism shall be considered in the measurement.</p> <p>In order to minimize the effect of the <math>W</math>-axis roll on the <math>E_{B(0Z)W}</math> measurements, ensure that the measurement trajectory on the straightedge is as close as possible to a horizontal plane containing the spindle axis.</p> <p>The spindle rotation shall be locked. Touch the surface of the straightedge with the dial gauge stylus and zero it. Extend the spindle to the required length and record the dial gauge reading. The measured parallelism error, <math>E_{B(0Z)W}</math>, is the ratio between the reading and the travelled distance along the <math>W</math>-axis.</p> |                           |            |

7.3 Fixed table independent of the machine

|  |  |            |        |                           |        |
|--|--|------------|--------|---------------------------|--------|
| <b>Object</b>  |  | <b>G11</b> |        |                           |        |
| Checking of the flatness of the fixed table surface.   |  |            |        |                           |        |
| <b>Diagram</b>   |  |            |        |                           |        |
|  |  |            |        |                           |        |
| <b>Key</b>   |  |            |        |                           |        |
| <i>d</i> measuring distance  |  |            |        |                           |        |
| <b>Tolerance</b>   | for length of the longest side of the table up to: |            |        | <b>Measured deviation</b> |        |
|  | 5 000  | 10 000     | 15 000 |                           | 20 000 |
| flatness tolerance:  | 0,12   | 0,22       | 0,32   |                           | 0,42   |
| For table lengths over 20 000, the tolerance shall be agreed upon between manufacturer/supplier and user.  |  |            |        |                           |        |
| <b>Measuring instruments</b>   |  |            |        |                           |        |
| Precision level or optical methods.  |  |            |        |                           |        |
| <b>Observations and references to ISO 230-1:2012, 12.2.4 and 12.2.5</b>  |  |            |        |                           |        |
| Measurements shall be carried out at a number of positions equally spaced with measuring distance, <i>d</i> , not exceeding 1/10 of the longest side of the table. |  |            |        |                           |        |
| NOTE Flatness measurements can also be performed by measurements along diagonals (see ISO 230-1:2012, 12.2.42).  |  |            |        |                           |        |

|  |            |
|--|------------|
| <b>Object</b>  | <b>G12</b> |
| Checking of parallelism between the reference T-slot, or any other reference surface of the fixed table, and the column movement (X-axis). |            |

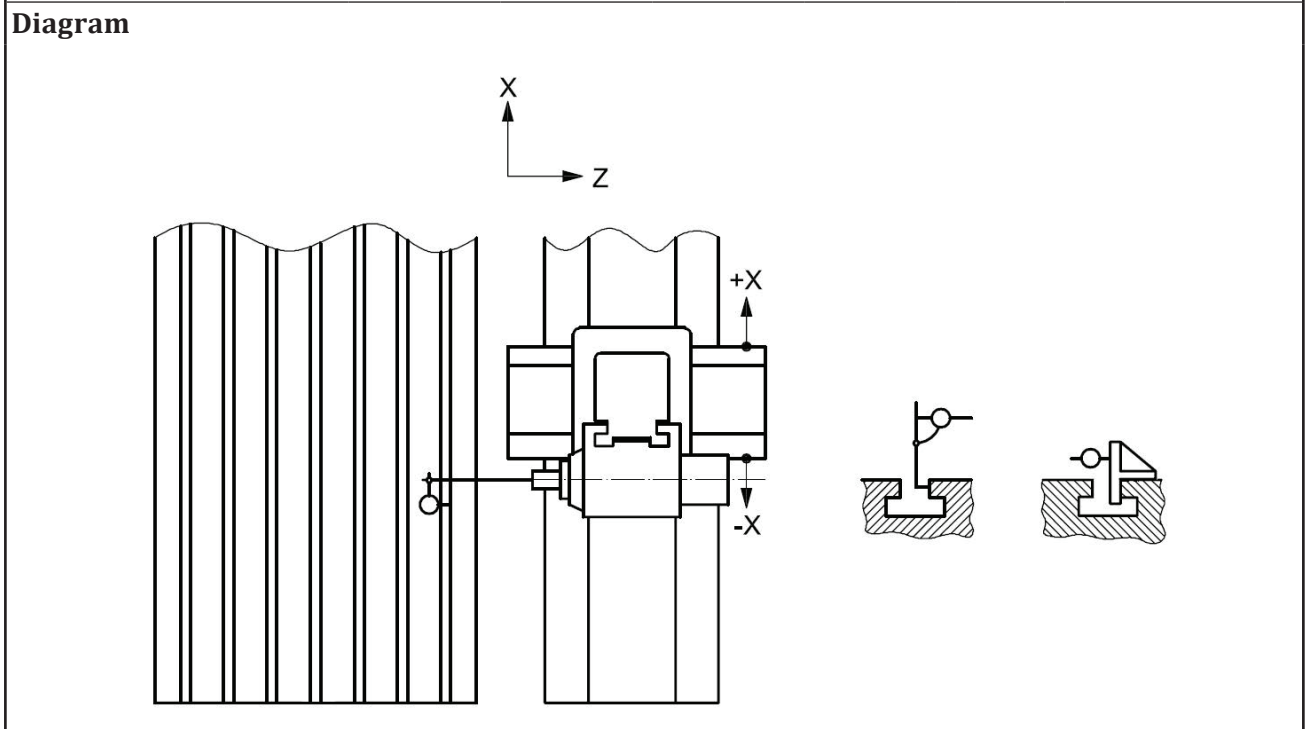

|   |  |                                |
|---|--|--------------------------------|
| <b>Tolerance</b>  | for length of the longest side of the table up to: | <b>Measured deviation</b>      |
|   | 5 000    10 000    15 000    20 000                |                                |
| parallelism tolerance:  | 0,15    0,20    0,25    0,30                       | For a measurement distance of: |
| For table lengths over 20 000, the tolerance shall be agreed upon between manufacturer/supplier and user. |  | Over a table length of:        |
|   |  | 0,202    0,337                 |

**Measuring instruments**  
Dial gauge and cross-square.

**Observations and references to ISO 230-1:2012, 12.3.2.5.2**

If the spindle can be locked, the dial gauge may be mounted on it. If the spindle cannot be locked, the dial gauge shall be placed on the ram face.

Measurements shall be carried out at a number of positions equally spaced at steps not exceeding 1/10 of the longest side of the table.

Traverse the X-axis from one measurement position to the following without contact between the stylus and the reference surface. At each measurement position, either move down the Y-axis to bring the dial gauge into contact with the reference surface or insert the cross-square between the stylus and the table surface.

The parallelism error is the difference between the maximum and the minimum reading.

|  |  |        |        |  |
|--|--|--------|--------|--|
| <b>Object</b>  |  |        |        | <b>G13</b>                             |
| Checking of parallelism between the fixed table surface and the column movement (X-axis).  |  |        |        |  |
| <b>Diagram</b>   |  |        |        |  |
|  |  |        |        |  |
| <b>Tolerance</b>   | for length of the longest side of the table up to: |        |        |  |
|  | 5000   | 10 000 | 15 000 | 20 000                                 |
| parallelism tolerance:   | 0,10   | 0,20   | 0,30   | 0,40                                   |
| For table lengths over 20 000, the tolerance shall be agreed upon between manufacturer/supplier and user.  |  |        |        | <b>Measured deviation</b>              |
|  |  |        |        | For a measurement distance of:         |
|  |  |        |        | Over a table length of: 0,54 (max 0,3) |
| <b>Measuring instruments</b>   |  |        |        |  |
| Dial gauge and gauge block or optical method.  |  |        |        |  |
| <b>Observations and references to ISO 230-1:2012, 12.3.2.5.2</b>   |  |        |        |  |
| If the spindle can be locked, the dial gauge may be mounted on it. If the spindle cannot be locked, the dial gauge shall be placed on the ram face.  |  |        |        |  |
| The ram shall be positioned at mid-travel.   |  |        |        |  |
| Prior to the measurement, each measurement spot may be manually smoothed by an abrasive stone, in order to minimize small inaccuracy of the table surface.   |  |        |        |  |
| Traverse the X-axis from one measurement position to the following without contact between the stylus and the table surface. At each measurement position, insert the gauge block between the stylus and the table surface and take the reading. |  |        |        |  |
| The parallelism error is the difference between the maximum and the minimum reading.   |  |        |        |  |

|  |                           |
|--|---------------------------|
| <b>Object</b>  | <b>G14</b>                |
| Checking of parallelism between the surface of the fixed table and the ram movement (Z-axis).  |                           |
| <b>Diagram</b>   |                           |
|  |                           |
| <b>Tolerance</b>   | <b>Measured deviation</b> |
| 0,07 over a measuring length of 1 000  |                           |
| <b>Measuring instruments</b>   |                           |
| Straightedge and dial gauge.   |                           |
| <b>Observations and references to ISO 230-1:2012, 12.3.2.5.2</b>   |                           |
| <p>If the spindle can be locked, the dial gauge may be mounted on it. If the spindle cannot be locked, the dial gauge shall be placed on the ram face.</p> <p>This test shall be carried out in at least three positions of the column (X-axis) along the bed (at 10 %, 50 % and 90 % of travel/table length).</p> |                           |
| <p>Set the straightedge on the fixed table in Z-axis direction parallel to the table surface; traverse the ram through the measuring length and note the variation in readings. Without using the straight-edge, direct measurement of the table surface using dial gauge and gauge block is also possible.</p>    |                           |
| <p>The parallelism error is the difference between the maximum and the minimum reading.</p>  |                           |

### 7.4 Boring spindle

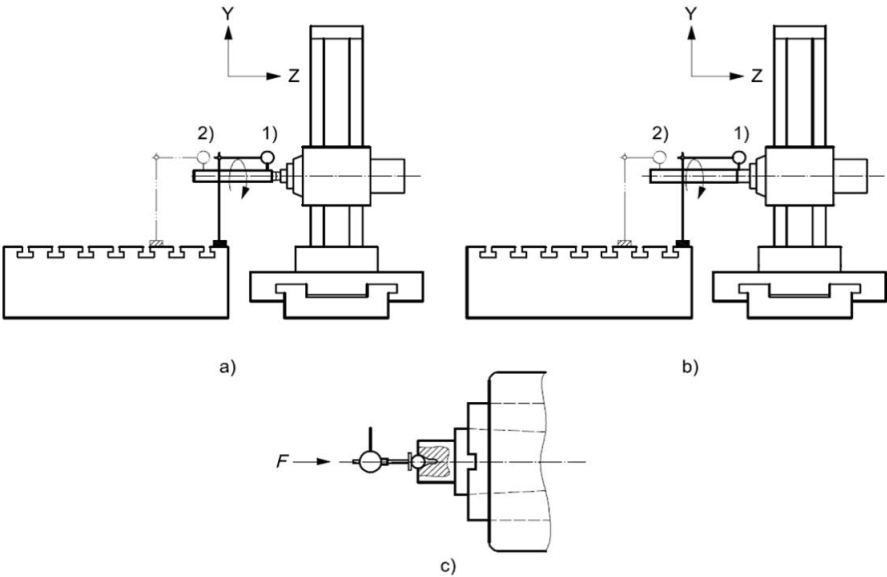
| Object  |    | G15                        |                    |              |                    |           |               |    |      |       |      |    |      |      |      |        |  |      |       |      |   |  |  |    |    |    |    |    |    |    |
|---|----|----------------------------|--------------------|--------------|--------------------|-----------|---------------|----|------|-------|------|----|------|------|------|--------|--|------|-------|------|---|--|--|----|----|----|----|----|----|----|
| <p>Checking of the boring spindle:</p> <p>a) run-out of the internal taper, spindle retracted:</p> <ol style="list-style-type: none"> <li>1) close to the spindle gauge line;</li> <li>2) at a distance of 300 from the spindle nose;</li> </ol> <p>b) run-out of the external diameter:</p> <ol style="list-style-type: none"> <li>1) with the spindle retracted;</li> <li>2) with the spindle extended 300;</li> </ol> <p>c) axial error, with the spindle retracted, <math>E_{Z(C)}</math>.</p>                                |    |                            |                    |              |                    |           |               |    |      |       |      |    |      |      |      |        |  |      |       |      |   |  |  |    |    |    |    |    |    |    |
| <p><b>Diagram</b></p>    |    |                            |                    |              |                    |           |               |    |      |       |      |    |      |      |      |        |  |      |       |      |   |  |  |    |    |    |    |    |    |    |
| <b>Tolerance</b>  |    | <b>Measured deviations</b> |                    |              |                    |           |               |    |      |       |      |    |      |      |      |        |  |      |       |      |   |  |  |    |    |    |    |    |    |    |
| <table border="1"> <thead> <tr> <th></th> <th></th> <th><math>D \leq 125</math></th> <th><math>125 &lt; D \leq 200</math></th> <th><math>D &gt; 200</math></th> </tr> </thead> <tbody> <tr> <td rowspan="2">for a) and b)</td> <td>1)</td> <td>0,01</td> <td>0,015</td> <td>0,02</td> </tr> <tr> <td>2)</td> <td>0,02</td> <td>0,03</td> <td>0,04</td> </tr> <tr> <td>for c)</td> <td></td> <td>0,01</td> <td>0,015</td> <td>0,02</td> </tr> </tbody> </table> <p>where <math>D</math> is the diameter of the boring spindle.</p> |    |                            |                    | $D \leq 125$ | $125 < D \leq 200$ | $D > 200$ | for a) and b) | 1) | 0,01 | 0,015 | 0,02 | 2) | 0,02 | 0,03 | 0,04 | for c) |  | 0,01 | 0,015 | 0,02 | <table border="1"> <tbody> <tr> <td>a)</td> </tr> <tr> <td>1)</td> </tr> <tr> <td>2)</td> </tr> <tr> <td>b)</td> </tr> <tr> <td>1)</td> </tr> <tr> <td>2)</td> </tr> <tr> <td>c)</td> </tr> </tbody> </table> |  |  | a) | 1) | 2) | b) | 1) | 2) | c) |
|   |    | $D \leq 125$               | $125 < D \leq 200$ | $D > 200$    |                    |           |               |    |      |       |      |    |      |      |      |        |  |      |       |      |   |  |  |    |    |    |    |    |    |    |
| for a) and b)   | 1) | 0,01                       | 0,015              | 0,02         |                    |           |               |    |      |       |      |    |      |      |      |        |  |      |       |      |   |  |  |    |    |    |    |    |    |    |
|   | 2) | 0,02                       | 0,03               | 0,04         |                    |           |               |    |      |       |      |    |      |      |      |        |  |      |       |      |   |  |  |    |    |    |    |    |    |    |
| for c)  |    | 0,01                       | 0,015              | 0,02         |                    |           |               |    |      |       |      |    |      |      |      |        |  |      |       |      |   |  |  |    |    |    |    |    |    |    |
| a)  |    |                            |                    |              |                    |           |               |    |      |       |      |    |      |      |      |        |  |      |       |      |   |  |  |    |    |    |    |    |    |    |
| 1)  |    |                            |                    |              |                    |           |               |    |      |       |      |    |      |      |      |        |  |      |       |      |   |  |  |    |    |    |    |    |    |    |
| 2)  |    |                            |                    |              |                    |           |               |    |      |       |      |    |      |      |      |        |  |      |       |      |   |  |  |    |    |    |    |    |    |    |
| b)  |    |                            |                    |              |                    |           |               |    |      |       |      |    |      |      |      |        |  |      |       |      |   |  |  |    |    |    |    |    |    |    |
| 1)  |    |                            |                    |              |                    |           |               |    |      |       |      |    |      |      |      |        |  |      |       |      |   |  |  |    |    |    |    |    |    |    |
| 2)  |    |                            |                    |              |                    |           |               |    |      |       |      |    |      |      |      |        |  |      |       |      |   |  |  |    |    |    |    |    |    |    |
| c)  |    |                            |                    |              |                    |           |               |    |      |       |      |    |      |      |      |        |  |      |       |      |   |  |  |    |    |    |    |    |    |    |
| <p><b>Measuring instruments</b></p> <p>For a) and b): dial gauge with test mandrel.</p> <p>For c) dial gauge with flat-ended stylus and test sphere.</p>  |    |                            |                    |              |                    |           |               |    |      |       |      |    |      |      |      |        |  |      |       |      |   |  |  |    |    |    |    |    |    |    |
| <p><b>Observations and references to for a) and b) ISO 230-1:2012, 12.5.2; for c) ISO 230-7:2015, 5.4.4</b></p> <p>The value and the direction of application of the force, <math>F</math>, shall be specified by the manufacturer/supplier. When preloaded bearings are used, no force needs to be applied.</p> <p>NOTE Test AR1 is a spindle test for evaluating error motions of the spindle axis of rotation.</p>   |    |                            |                    |              |                    |           |               |    |      |       |      |    |      |      |      |        |  |      |       |      |   |  |  |    |    |    |    |    |    |    |

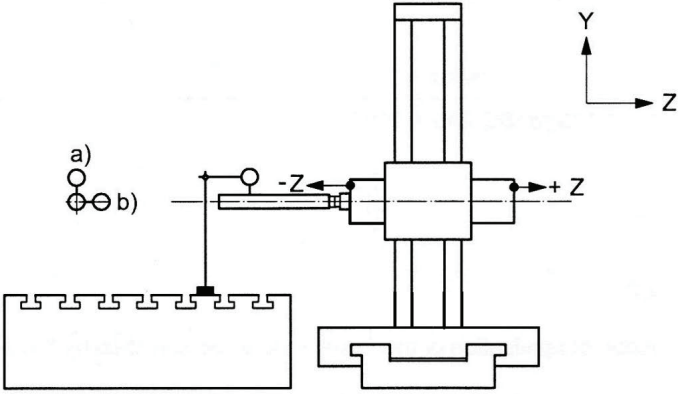
|   |   |  |
|---|---|--|
| <b>Object</b>   | <b>G16</b>  |  |
| <p>Checking of parallelism between the axis average line of the boring spindle axis of rotation and the ram movement (Z-axis):</p> <p>a) in the vertical YZ-plane, <math>E_{A(0Z)}(C)</math>;</p> <p>b) in the horizontal ZX-plane, <math>E_{B(0Z)}(C)</math>.</p>  |   |  |
| <p><b>Diagram</b></p>   |   |  |
| <p><b>Tolerance</b></p> <p style="text-align: center;">For a) and b)<br/> <math>0,02/300</math></p>   | <p><b>Measured deviations</b></p> <p>a)</p> <p>b)</p> |  |
| <p><b>Measuring instruments</b></p> <p>Test mandrel and dial gauge</p>  |   |  |
| <p><b>Observations and references to ISO 230-1:2012, 10.1.4</b></p> <p>Measurements are performed by moving the Z-axis and shall be carried out with the aid of the test mandrel mounted in the spindle nose. The boring spindle (W-axis) shall be retracted.</p> <p>Carry out the measurement at the mean position of run-out of the spindle rotation or evaluate the mean value of measurements taken at two positions of the spindle rotation at 180° apart.</p> <p>The orientation of the parallelism deviation between the boring spindle axis and the Z-axis, in both planes, shall be noted.</p> |   |  |

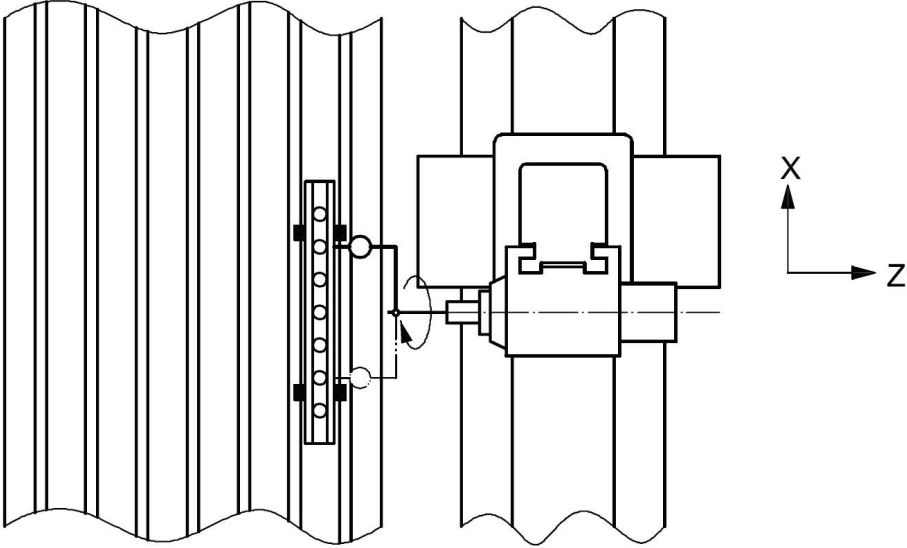
|   |                           |
|---|---------------------------|
| <b>Object</b>   | <b>G17</b>                |
| Checking of squareness between the axis average line of the boring spindle axis and the column movement (X-axis), $E_{B(0X)(C)}$ .  |                           |
| <b>Diagram</b><br>   |                           |
| <b>Tolerance</b><br><p style="text-align: center;">0,04/1 000</p> (1 000 is the distance between the two measuring points touched)  | <b>Measured deviation</b> |
| <b>Measuring instruments</b><br>Dial gauge, special arm and straightedge.   |                           |
| <b>Observations and references to ISO 230-1:2012, 10.3.3</b><br><p>The ram (Z-axis) shall be locked. The spindle shall be retracted.</p> <p>Set the straightedge horizontally on the fixed table and align it to the column movement (X-axis) or the lack of parallelism shall be considered in the measurement.</p> <p>Set the dial gauge on the special arm mounted to the spindle. Touch the surface of the straightedge with the dial gauge stylus and zero it.</p> <p>Turn the boring spindle until the stylus touches the reference face of the straightedge again and note the reading.</p> <p>The difference between the two readings divided by the distance between the two measuring points is the squareness error, <math>E_{B(0X)(C)}</math>.</p> <p>The special arm shall be stiff enough so as to prevent any possible reading errors due to its opposite deflections in the two measurement positions.</p> <p>The X-axis position and the Y-axis position of the test shall be recorded.</p> <p>The value of the angle, <math>\alpha</math>, being less than, equal to or greater than <math>90^\circ</math>, shall be noted.</p> |                           |

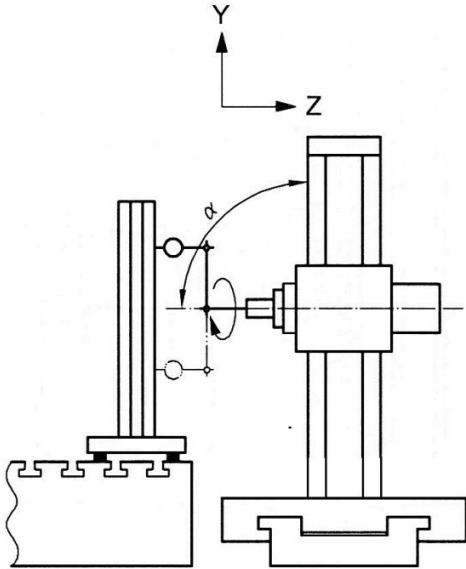

|  |                           |
|--|---------------------------|
| <b>Object</b>  | <b>G18</b>                |
| Checking of squareness between the axis average line of the boring spindle axis and the spindle head movement (Y-axis), $E_{A(0Y)(C)}$ .   |                           |
| <b>Diagram</b><br>  |                           |
| <b>Tolerance</b><br>$0,04/1000$ with $\alpha \leq 90^\circ$<br>(1 000 is the distance between the two measuring points touched)  | <b>Measured deviation</b> |
| <b>Measuring instruments</b><br>Square, surface plate, adjustable blocks, dial gauge and special arm   |                           |
| <b>Observations and references to ISO 230-1:2012, 10.3.3</b><br><p>Set a surface plate on the table and then place a cylindrical square on it. Adjust the surface plate until the square is parallel to the spindle head movement (Y-axis) using adjustable blocks or the lack of parallelism shall be considered in the measurement.</p> <p>The spindle and the ram shall be retracted.</p> <p>Set the dial gauge on the special arm mounted to the spindle. Place the stylus of the dial gauge against the square. Zero the dial gauge. Turn the boring spindle until the stylus touches the square again. Record the reading.</p> <p>The difference between the two readings divided by the distance between the two measuring points is the measured squareness error, <math>E_{A(0Y)(C)}</math>.</p> <p>This test may also be performed without the square, by placing the dial gauge support on the table and touching with the stylus a point on a special arm fixed on the spindle, thus avoiding any possible deflection of the dial gauge arm and making the reading easier. The spindle axis shall be rotated <math>180^\circ</math> and the Y-axis shall be moved in order to make the stylus touch the special arm in the same point. In this case, the measurement is influenced by the <math>E_{ZY}</math> straightness error of the Y-axis.</p> <p>The special arm shall be stiff enough so as to prevent any possible reading errors due to its opposite deflections in the two measurement positions.</p> <p>The Y-axis position of the test shall be recorded.</p> <p>The value of the angle, <math>\alpha</math>, being less than, equal to or greater than <math>90^\circ</math>, shall be noted.</p> |                           |

## 7.5 Milling spindle

|   |    |              |                    |                            |
|---|----|--------------|--------------------|----------------------------|
| <b>Object</b>   |    |              |                    | <b>G19</b>                 |
| Checking of the milling spindle nose:<br>a) run-out of the external cylindrical centring surface;<br>b) axial error, $E_{Z(C)}$ ;<br>c) face run-out of the spindle nose (including axial error). |    |              |                    |                            |
| <b>Diagram</b>  |    |              |                    |                            |
|   |    |              |                    |                            |
| <b>Tolerance</b>  |    |              |                    | <b>Measured deviations</b> |
|   |    | $D \leq 125$ | $125 < D \leq 200$ | $D > 200$                  |
| for a) and b)   | 1) | 0,01         | 0,015              | 0,02                       |
|   | 2) | 0,01         | 0,015              | 0,02                       |
| for c)  |    | 0,02         | 0,03               | 0,04                       |
| where $D$ is the diameter of the boring spindle.  |    |              |                    |                            |
| <b>Measuring instruments</b>  |    |              |                    |                            |
| Dial gauge [with flat-ended stylus for b)]  |    |              |                    |                            |
| <b>Observations and references for a) and c) to ISO 230-1:2012, 12.5.2; for b) ISO 230-7:2015, 5.4.4.</b>   |    |              |                    |                            |
| The value and the direction of application of the force, $F$ , shall be specified by the manufacturer/supplier. When preloaded bearings are used, no force needs to be applied.                   |    |              |                    |                            |
| The distance $A$ of the dial gauge c) from the spindle axis shall be as large as possible.  |    |              |                    |                            |
| NOTE Test AR1 is a spindle test for evaluating error motions of the spindle axis of rotation.   |    |              |                    |                            |

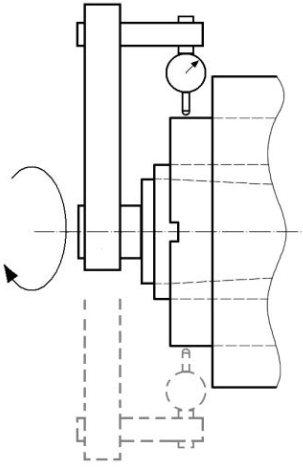
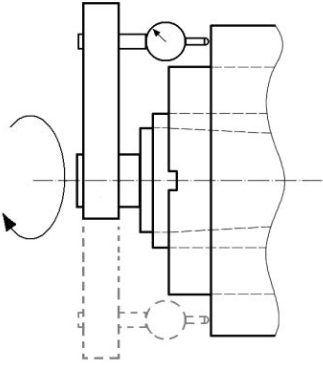
|   |   |
|---|---|
| <b>Object</b>   | <b>G20</b>  |
| <p>a) Checking of concentricity between the axis average line of the spindle and the external cylindrical centring of tools or accessories on the ram.</p> <p>b) Checking of squareness between the support face of tools or accessories on the ram and the axis average line of the axis of rotation of the spindle.</p> <p>NOTE These checks are valid only if there is a circular locating surface on the ram.</p> |   |
| <p><b>Diagram</b></p> <div style="display: flex; justify-content: space-around; align-items: center;"> <div style="text-align: center;">  <p>a)</p> </div> <div style="text-align: center;">  <p>b)</p> </div> </div>                           |   |
| <p><b>Tolerance</b></p> <p style="margin-left: 40px;">a) 0,02</p> <p style="margin-left: 40px;">b) 0,02/500</p> <p>(500 is the distance between the two measuring points touched)</p>   | <p><b>Measured deviations</b></p> <p>a)</p> <p>b)</p> |
| <p><b>Measuring instruments</b></p> <p>Dial gauge and special arm</p>   |   |
| <p><b>Observations and references to ISO 230-1:2012</b></p> <p>a) ISO 230-1:2012, 12.3.4</p> <p>Concentricity deviation is the half of the maximum difference of the readings.</p> <p>b) ISO 230-1:2012, 12.4.8</p>   |   |

## 7.6 Rotary and movable table

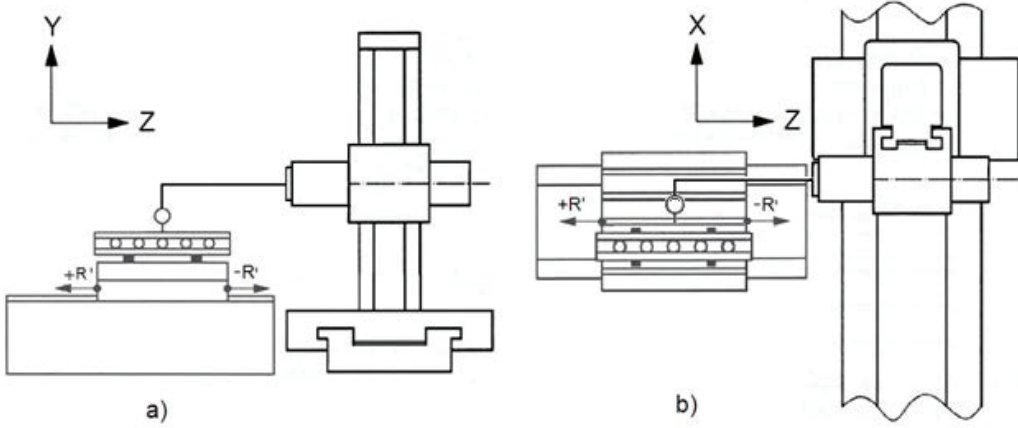
|  |   |
|--|---|
| <p><b>Object</b></p> <p>Checking of straightness of the table slide movement (R'-axis):</p> <p>a) in the vertical YZ plane, <math>E_{YR}</math>;</p> <p>b) in the horizontal ZX plane, <math>E_{XR}</math>.</p>  | <p><b>G21</b></p>                                     |
| <p><b>Diagram</b></p>  <p>The diagram illustrates two measurement configurations for checking the straightness of a table slide movement. Configuration (a) shows a vertical YZ plane with a dial gauge measuring the table slide movement. Configuration (b) shows a horizontal ZX plane with a dial gauge measuring the table slide movement. Both configurations include a coordinate system and labels for +R' and -R' directions.</p>  |   |
| <p><b>Tolerance</b></p> <p style="text-align: center;">for a) and b)</p> <p style="text-align: center;">0,02 for measuring lengths up to 1 000</p> <p style="text-align: center;">Add 0,01 to the preceding tolerance for each 1 000 increase in length beyond 1 000</p> <p style="text-align: center;">Maximum tolerance: 0,05</p>  | <p><b>Measured deviations</b></p> <p>a)</p> <p>b)</p> |
| <p><b>Measuring instruments</b></p> <p>Straightedge, dial gauge and gauge blocks, or optical methods or taut wire and microscope for b).</p> <p><b>Observations and references to ISO 230-1:2012, 8.2.2.1, 8.2.2.3 and 8.2.2.5</b></p> <p>Set a straightedge on the table, vertically for a) and horizontally for b), parallel to the R'-axis movement of the table slide or the lack of parallelism shall be considered in the measurement.</p> <p>If the spindle can be locked, the dial gauge may be mounted on it. If the spindle cannot be locked, the dial gauge shall be mounted on the ram face. The stylus shall be normal to the reference face of the straightedge.</p> <p>Traverse the table in the R'-axis direction and note the readings.</p> |   |

|   |   |
|---|---|
| <p><b>Object</b></p> <p>Checking of angular deviation of the table slide movement (<math>R'</math>-axis):</p> <p>a) in the vertical <math>YZ</math> plane, <math>E_{AR}</math> (pitch);</p> <p>b) in the vertical <math>XY</math> plane, <math>E_{CR}</math> (roll);</p> <p>c) in the horizontal <math>ZX</math> plane, <math>E_{BR}</math> (yaw).</p>  | <p><b>G22</b></p>   |
| <p><b>Diagram</b></p>   |   |
| <p><b>Key</b></p> <p>1 measuring levels</p> <p>2 reference levels</p> <p>3 laser head</p> <p>4 angle interferometer</p> <p>5 retro-reflectors</p>   |   |
| <p><b>Tolerance</b></p> <p style="text-align: center;">for a), b) and c)</p> <p style="text-align: center;"><math>R \leq 4\ 000</math>: 0,04/1 000</p> <p style="text-align: center;"><math>R &gt; 4\ 000</math>: 0,06/1 000</p> <p style="text-align: center;">Local tolerance: 0,02/1 000 for any measuring length of 300</p>   | <p><b>Measured deviations</b></p> <p>a)</p> <p>b)</p> <p>c)</p> |
| <p><b>Measuring instruments</b></p> <p>a) Precision levels, laser interferometer or other optical angular deviation measuring instruments.</p> <p>b) Precision levels.</p> <p>c) Laser interferometer or other optical angular deviation measuring instruments.</p>   |   |
| <p><b>Observations and references to ISO 230-1:2012, 3.4.16 and 8.4</b></p> <p>The level or instrument shall be placed on the table:</p> <p>a) <math>E_{AR}</math> (pitch) in the <math>Z</math>-axis direction (with optical instruments set vertically);</p> <p>b) <math>E_{CR}</math> (roll) in the <math>X</math>-axis direction;</p> <p>c) <math>E_{BR}</math> (yaw) in the <math>Z</math>-axis direction (with optical instruments set horizontally).</p> <p>The reference level shall be located on the ram and the ram shall be in the middle of the travel range.</p> <p>When <math>R'</math>-axis motion causes an angular movement of both spindle head and work holding table, differential measurements of the two angular movements shall be made and this shall be stated.</p> |   |

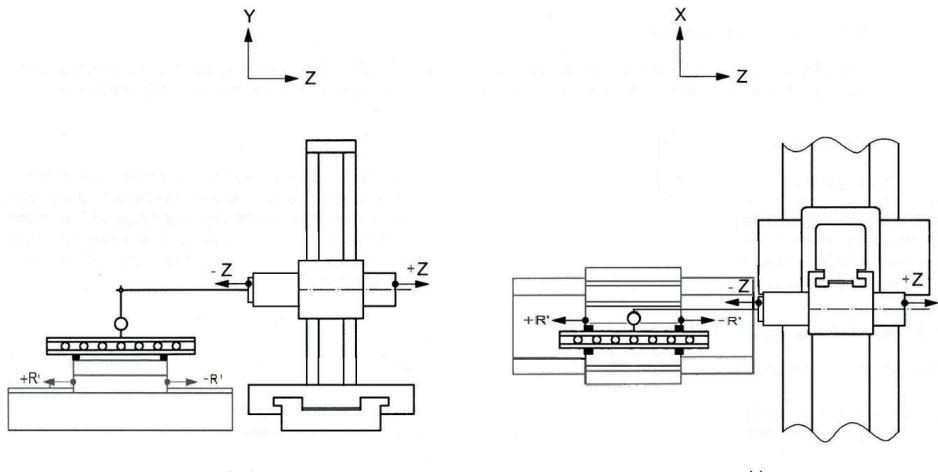
|  |  |
|--|--|
| <b>Object</b>  | <b>G23</b>                             |
| Checking of parallelism between the table slide movement ( $R'$ -axis) and the ram movement ( $Z$ -axis):<br>a) in the vertical $YZ$ -plane, $E_{A(0Z)R}$ ;<br>b) in the horizontal $ZX$ -plane, $E_{B(0Z)R}$ .  |  |
| <b>Diagram</b><br>   |  |
| <b>Tolerance</b><br>a) and b)<br>0,03/500  | <b>Measured deviations</b><br>a)<br>b) |
| <b>Measuring instruments</b><br>Straightedge, dial gauge and adjustable blocks.  |  |
| <b>Observations and references to ISO 230-1:2012, 10.1.2</b><br>Set a straightedge on the table, vertical for a) and horizontal for b), parallel to the ram movement ( $Z$ -axis) or the lack of parallelism shall be considered in the measurement.<br>If the spindle can be locked, the dial gauge may be mounted on it. If the spindle cannot be locked, the dial gauge shall be placed on the ram face.<br>Apply the stylus of the dial gauge to the straightedge, measuring in the $Y$ -direction for a) and in the $X$ -direction for b). Retract the ram and zero the dial gauge.<br>Move the $R'$ -axis to the required position and record the dial gauge reading. The measured parallelism error, $E_{A(0Z)R}$ , for a) or $E_{B(0Z)R}$ , for b), is the ratio between the reading and the travelled distance along the $R'$ -axis.<br>NOTE These tests can also be performed with single point measurements (synchronous movements of $Z$ -axis and $R'$ -axis) |  |

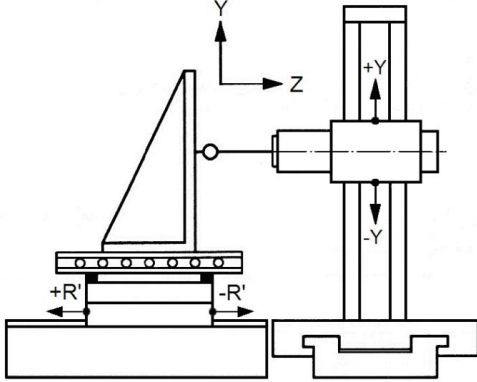
|  |                                   |
|--|-----------------------------------|
| <b>Object</b>  | <b>G24</b>                        |
| Checking of squareness between) the table slide movement ( $R'$ -axis) and the spindle head movement ( $Y$ -axis), $E_{A(0R)Y}$ .  |                                   |
| <p><b>Diagram</b></p>    |                                   |
| <p><b>Tolerance</b></p> <p style="text-align: center;">0,04/1 000</p>  | <p><b>Measured deviations</b></p> |
| <p><b>Measuring instruments</b></p> <p>Square, straightedge, adjustable blocks and dial gauge.</p>   |                                   |
| <p><b>Observations and references to ISO 230-1:2012, 10.3.2</b></p> <p>Set a straightedge on the table parallel to the table slide movement (<math>R'</math>-axis) using adjustable blocks or the lack of parallelism shall be considered in the measurement. Place a square on the straightedge.</p> <p>If the spindle can be locked, the dial gauge may be mounted on it. If the spindle cannot be locked, the dial gauge shall be placed on the ram face.</p> <p>Apply the stylus of the dial gauge to the square, measuring in the <math>Z</math>-direction. Position the <math>Y</math>-axis to measure close to one end of the square surface and zero the dial gauge.</p> <p>Move the <math>Y</math>-axis to measure close to the other end of the square surface and note the reading.</p> <p>The measured squareness error, <math>E_{A(0Y)R}</math>, is the ratio between the reading and the travelled distance along the <math>Y</math>-axis.</p> |                                   |

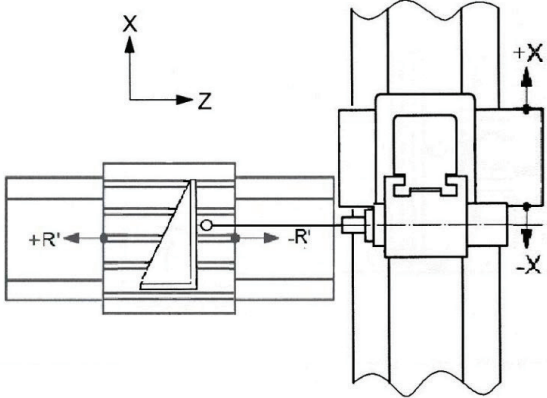
|   |                           |
|---|---------------------------|
| <b>Object</b>   | <b>G25</b>                |
| Checking of squareness between the table slide movement (R'-axis) and the column movement (X-axis), $E_{B(OX)R}$ .  |                           |
| <b>Diagram</b><br>  |                           |
| <b>Tolerance</b><br><p style="text-align: center;">0,04/1 000</p>   | <b>Measured deviation</b> |
| <b>Measuring instruments</b><br>Square and dial gauge   |                           |
| <b>Observations and references to ISO 230-1:2012, 10.3.2</b><br><p>Set a square on the table and align one side parallel to the column movement (X-axis) or the lack of parallelism shall be considered in the measurement.</p> <p>If the spindle can be locked, the dial gauge may be mounted on it. If the spindle cannot be locked, the dial gauge shall be placed on the ram face.</p> <p>Apply the stylus of the dial gauge to the square, measuring in the X-axis direction. Position the R'-axis to measure close to one end of the square surface and zero the dial gauge.</p> <p>Move the R'-axis to measure close to the other end of the square surface and note the reading. The measured squareness error, <math>E_{B(OX)R}</math>, is the ratio between the reading and the travelled distance along the R'-axis.</p> |                           |

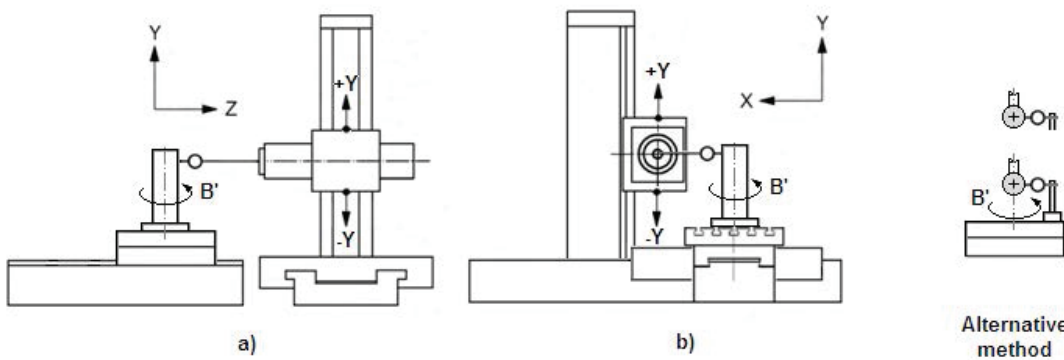

|   |  |
|---|--|
| <b>Object</b>   | <b>G26</b>   |
| <p>Checking of parallelism error between the B'-axis of rotation of the table and the Y-axis motion:</p> <p>a) <math>E_{A(0Y)B}</math> in the vertical YZ plane;</p> <p>b) <math>E_{C(0Y)B}</math> in the vertical XY plane.</p>  |  |
| <p><b>Diagram</b></p>  <p>The diagram illustrates two measurement setups. Setup (a) shows a dial gauge mounted on the spindle head, measuring a cylinder square on the table. The stylus is oriented in the Z-axis direction. Setup (b) shows a similar setup but with the stylus oriented in the X-axis direction. An alternative method is shown to the right, featuring a test sphere on the spindle head and a linear displacement sensor on the table.</p>   |  |
| <p><b>Tolerance</b></p> <p style="text-align: center;">0,04/1 000</p>   | <p><b>Measured deviations</b></p> <p>a)<br/>b)</p> |
| <p><b>Measuring instruments</b></p> <p>Cylinder square with flange base and dial gauge</p>  |  |
| <p><b>Observations and references to ISO 230-1:2012, 3.6.4, 10.1.4, 10.1.4.3, or 10.1.4.4 as alternative</b></p> <p>If the spindle can be locked, the dial gauge may be mounted on it. If the spindle cannot be locked, the dial gauge shall be mounted on the spindle head.</p> <p>a) Z-axis to be locked, if possible.</p> <p>b) X-axis to be locked, if possible.</p> <ol style="list-style-type: none"> <li>1) Fix a cylinder square with a flange base on the table and centre it approximately on the axis of rotation.</li> <li>2) Fix the dial gauge with the stylus oriented in the Z-axis direction for a) and X-axis direction for b).</li> <li>3) Touch the cylinder square by the stylus, close to the cylinder bottom, and find the maximum reading by making small movements along the X-axis for a) and along Z-axis for b). Zero the dial gauge.</li> <li>4) Move the head away from the table along the Y-axis and touch the cylinder close to its top again. Note the Y-axis travel length. Find the maximum reading by making small movements along the X-axis for a) and along Z-axis for b) and note the new reading.</li> <li>5) Turn the table by 180° and repeat steps 3) and 4).</li> <li>6) For both measurements a) and b), the average value (half the algebraic sum) of the two readings on top of the cylinder, divided by the Y-axis travel length, is the deviation to be reported.</li> </ol> |  |
| <p><b>Alternative method</b></p> <p>A test sphere shall be mounted on the spindle head of the machine and the linear displacement sensor shall be mounted on the table. The test sphere shall be centred with respect to the B'-axis average line by moving X-axis and Z-axis, while rotating the B'-axis. The Y-axis shall then be moved to another location. The displacement sensor is re-positioned to read against the test sphere at this new location. The error in the centre position shall be recorded as half the difference of the readings of the displacement sensor at opposite points on the sphere. This alternative method can be used when it is possible to touch a complete horizontal circumference of the sphere (e.g. the sphere equator).</p> <p>The orientation of the parallelism deviation between the B'-axis and the Y-axis, in both planes, shall be noted.</p>  |  |

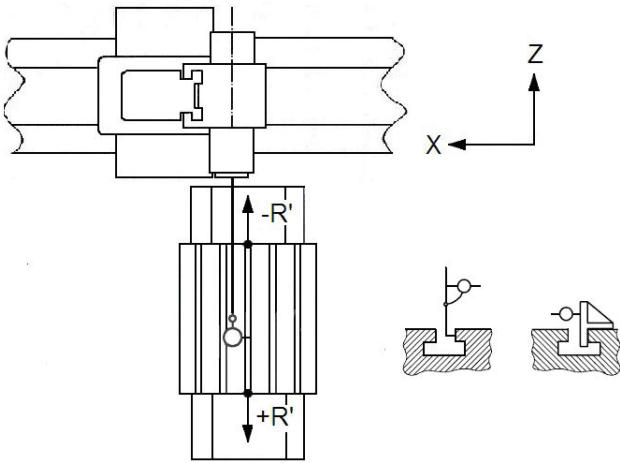
|  |                           |
|--|---------------------------|
| <b>Object</b>  | <b>G27</b>                |
| Checking of parallelism between the median or reference T-slot, in the rotary position B0, and the table slide movement (R'-axis).   |                           |
| <b>Diagram</b><br>   |                           |
| <b>Tolerance</b><br>0,03 for any measuring length of 1 000   | <b>Measured deviation</b> |
| <b>Measuring instruments</b><br>Dial gauge and cross-square  |                           |
| <b>Observations and references to ISO 230-1:2012, 12.3.2.5.1</b><br>If the spindle can be locked, the dial gauge may be mounted on it. If the spindle cannot be locked, the dial gauge shall be mounted on the ram face.<br>The stylus of the dial gauge may touch the reference face of T-slot directly or by using a cross-square.<br>Traverse the R'-axis from one measurement position to the following without contact between the stylus and the reference surface. At each measurement position, either move down the Y-axis to bring the dial gauge into contact with the reference surface or insert the cross-square between the stylus and the table surface.<br>The parallelism error is the difference between the maximum and the minimum reading. |                           |

## 7.7 Indexing or rotary tables

|  |  |                           |       |       |       |       |            |      |      |      |
|--|--|---------------------------|-------|-------|-------|-------|------------|------|------|------|
| <b>Object</b>  |  | <b>G28</b>                |       |       |       |       |            |      |      |      |
| Checking of face run-out of the table surface in its rotating movement.  |  |                           |       |       |       |       |            |      |      |      |
| <b>Diagram</b>   |  |                           |       |       |       |       |            |      |      |      |
|  |  |                           |       |       |       |       |            |      |      |      |
| <b>Key</b>   |  |                           |       |       |       |       |            |      |      |      |
| <i>D</i>   | measuring diameter   |                           |       |       |       |       |            |      |      |      |
| 1, 2, 3 and 4  | measurement positions  |                           |       |       |       |       |            |      |      |      |
| A, B, C and D  | table corners  |                           |       |       |       |       |            |      |      |      |
| <b>Tolerance</b>   | for a measuring diameter, <i>D</i> , up to:  | <b>Measured deviation</b> |       |       |       |       |            |      |      |      |
|  | <table border="1" style="margin-left: auto; margin-right: auto;"> <tr> <td>2 000</td> <td>3 000</td> <td>4 000</td> <td>5 000</td> </tr> <tr> <td>tolerance:</td> <td>0,04</td> <td>0,06</td> <td>0,08</td> <td>0,10</td> </tr> </table> |                           | 2 000 | 3 000 | 4 000 | 5 000 | tolerance: | 0,04 | 0,06 | 0,08 |
| 2 000  | 3 000  | 4 000                     | 5 000 |       |       |       |            |      |      |      |
| tolerance:   | 0,04   | 0,06                      | 0,08  | 0,10  |       |       |            |      |      |      |
| For measuring diameters, <i>D</i> , over 5 000, the tolerance shall be agreed upon between manufacturer/supplier and user.   |  |                           |       |       |       |       |            |      |      |      |
| <b>Measuring instruments</b>   |  |                           |       |       |       |       |            |      |      |      |
| Dial gauge and gauge block   |  |                           |       |       |       |       |            |      |      |      |
| <b>Observations and references to ISO 230-1:2012, 12.5</b>   |  |                           |       |       |       |       |            |      |      |      |
| <p>With the dial gauge in position 1, place a gauge block toward the corner A of the table and take the measurement. Take off the gauge block and rotate the table to B90 and take the measurement by inserting the same gauge block (toward corner B). Carry out the same operation toward the corners C and D by positioning the table to B180 and B270.</p> <p>Repeat the test reversing the B'-axis rotation direction (from D to A). Record the difference between the maximum and minimum readings.</p> <p>Repeat the same process, placing the dial gauge in the successive positions of 2, 3 and 4 or at least in position 2.</p> <p>Use the greatest of the recorded differences as the value of face run-out.</p> <p>Lock the table each time before taking measurements, if applicable.</p> |  |                           |       |       |       |       |            |      |      |      |

|   |       |                           |
|---|-------|---------------------------|
| <b>Object</b>   |       | <b>G29</b>                |
| Checking of run-out of the centring hole of the table in its rotating movement.   |       |                           |
| <b>Diagram</b>  |       |                           |
|   |       |                           |
| <b>Tolerance</b>  | 0,015 | <b>Measured deviation</b> |
| <b>Measuring instruments</b>  |       |                           |
| Dial gauge (lever type)   |       |                           |
| <b>Observations and references to ISO 230-1:2012, 12.5</b>  |       |                           |
| <p>If the spindle can be locked, the dial gauge may be mounted on it. If the spindle cannot be locked, the dial gauge shall be mounted on the ram face.</p> <p>Set the stylus of the dial gauge in the same plane with the axis of the centring hole and as near as possible to the table surface.</p> <p>Rotate the table and record the difference between the maximum and the minimum reading.</p> |       |                           |

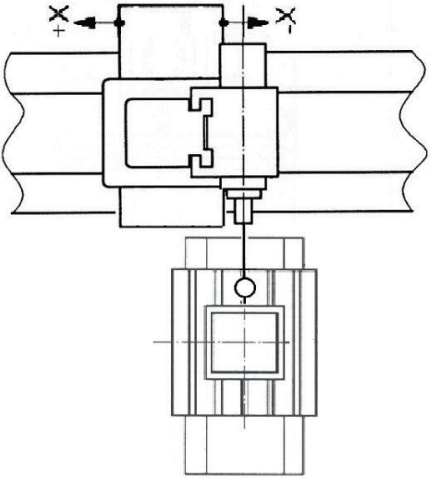
|   |  |
|---|--|
| <p><b>Object</b></p> <p>Checking of accuracy of the table angular positions at 0°, 90°, 180° and 270°.</p> <p>a) for rotary indexable table with only four fixed positions 90° apart.</p> <p>b) for rotary indexable table with any number of fixed positions.</p>  | <p><b>G30</b></p>                                    |
| <p><b>Diagram</b></p>    |  |
| <p><b>Tolerance</b></p> <p>a) 0,06/1 000</p> <p>b) 0,05/1 000</p>   | <p><b>Measured deviation</b></p> <p>a)</p> <p>b)</p> |
| <p><b>Measuring instruments</b></p> <p>Square and dial gauge or optical methods</p>   |  |
| <p><b>Observations and references to ISO 230-1:2012, 9.2</b></p> <p>For both a) and b):</p> <p>Set a square on the table with one edge parallel to the column movement (X-axis).</p> <p>Index the table four times in one direction (90°, 180°, 270° and 360°) and check in every position the parallelism (slope) between column movement and the corresponding edge of the square.</p> <p>Index the table four times in opposite direction (270°, 180°, 90° and 0°) and check again the parallelism (slope) in every position. The maximum difference of the eight readings is the measured deviation.</p> <p>NOTE Tests for checking of accuracy and repeatability of angular positioning of rotary table by numerical control (B'-axis), <math>E_{BB}</math> are specified in P6.</p> |  |

## 8 Checking accuracy and repeatability of positioning by numerical control

These tests are applied only to horizontal boring and milling machines, numerically controlled for linear and rotary positioning axes.

In performing the tests, reference should be made to ISO 230-2, especially for the environmental conditions, warming up of the machine, measuring methods, evaluation and interpretation of the results.

NOTE For editorial reasons, within this Clause, the symbol  $\bar{B}$  for the mean bi-directional positioning error of an axis has been adapted to the subscript Bmean (e.g.  $E_{XX, Bmean}$  is the symbol for the mean bi-directional positioning error of the X-axis).

|  |           |
|--|-----------|
| <b>Object</b>  | <b>P1</b> |
| Checking of accuracy and repeatability of positioning of the column movement (X-axis) by numerical control, $E_{XX}$ . |           |

**Diagram**

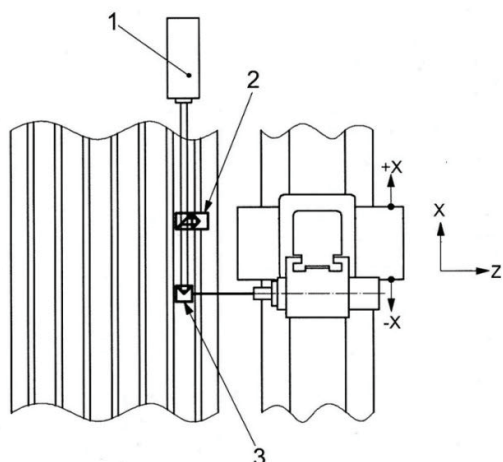

**Key**

- 1 laser head
- 2 interferometer
- 3 reflector

| Tolerance  |                        | Measured length                         |        |        | Measured deviation |
|--|------------------------|---|--------|--------|--------------------|
|  |                        | ≤500                                    | ≤1 000 | ≤2 000 |                    |
| Axes up to 2 000   |                        |   |        |        |                    |
| Bi-directional positioning accuracy of X-axis <sup>a</sup>   | $E_{XX,A}$             | 0,014                                   | 0,020  | 0,022  |                    |
| Unidirectional positioning repeatability of X-axis <sup>a</sup>  | $E_{XX,R↑}; E_{XX,R↓}$ | 0,007                                   | 0,009  | 0,011  |                    |
| Bi-directional positioning repeatability of X-axis   | $E_{XX,R}$             | 0,011                                   | 0,014  | 0,017  |                    |
| Mean reversal value of X-axis  | $E_{XX,Bmean}$         | 0,005                                   | 0,006  | 0,008  |                    |
| Bi-directional systematic positioning error of X-axis <sup>a</sup>   | $E_{XX,E}$             | 0,008                                   | 0,011  | 0,013  |                    |
| Mean bi-directional positioning error of X-axis <sup>a</sup>   | $E_{XX,M}$             | 0,003                                   | 0,005  | 0,006  |                    |
| Axes exceeding 2 000   |                        |   |        |        |                    |
| One or more segments of 2 000 with five runs upwards and downwards each.   |                        |   |        |        |                    |
| For axes up to 4 000 one full measurement over one 2 000 mm segment is recommended, for axes over 4 000 and up to 8 000 two 2 000 mm segments are recommended, and so forth. Test segments shall be equally spaced along the full axis length, with any excess length equally divided at the beginning, in between, and at the end of the test segments. |                        |   |        |        |                    |
| Bidirectional systematic positioning error of X-axis <sup>a</sup>  | $E_{XX,E}$             | 0,016 + 0,006 for each additional 1 000 |        |        |                    |
| Mean bi-directional positioning error of X-axis <sup>a</sup>   | $E_{XX,M}$             | 0,008 + 0,003 for each additional 1 000 |        |        |                    |

<sup>a</sup> May provide a basis for machine acceptance.

**Measuring instruments**

Laser measurement equipment or linear scale

**Observations and references to ISO 230-2:2014, Clause 3, 5.3.2 and 5.3.3**

The linear scale or the beam of laser measurement equipment shall be set parallel to the travelling axis.

Positioning feed speed shall be agreed between manufacturer/supplier and user.

The position of the starting point of measurement shall be stated.

Number and position of 2 000 test segment(s) shall be stated in the test report.

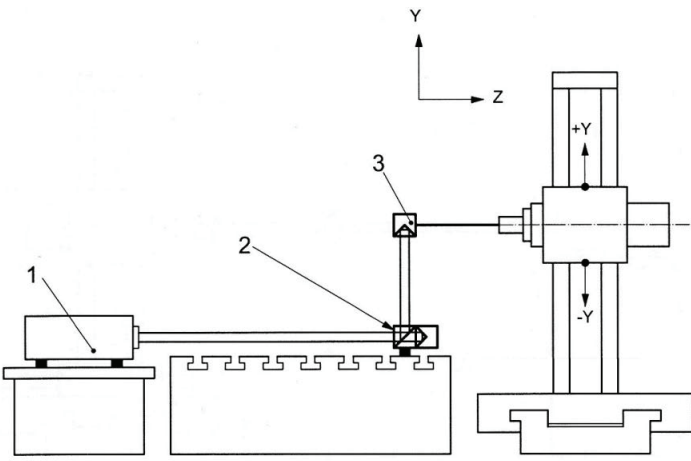
|   |                        |  |        |        |                           |
|---|------------------------|--|--------|--------|---------------------------|
| <b>Object</b>   |                        | <b>P2</b>  |        |        |                           |
| Checking of accuracy and repeatability of positioning of the spindle head movement (Y-axis) by numerical control, $E_{YY}$ .  |                        |  |        |        |                           |
| <b>Diagram</b>  |                        | <b>Key</b><br>1 laser head<br>2 interferometer<br>3 reflector                      |        |        |                           |
|   |                        |  |        |        |                           |
|   |                        |  |        |        |                           |
| <b>Tolerance</b>  |                        | <b>Measured length</b>   |        |        | <b>Measured deviation</b> |
|   |                        | ≤500   | ≤1 000 | ≤2 000 |                           |
| Axes up to 2 000  |                        |  |        |        |                           |
| Bi-directional positioning accuracy of Y-axis <sup>a</sup>  | $E_{YY,A}$             | 0,014  | 0,020  | 0,022  |                           |
| Unidirectional positioning repeatability of Y-axis <sup>a</sup>   | $E_{YY,RT}; E_{YY,RL}$ | 0,007  | 0,009  | 0,011  |                           |
| Bi-directional positioning repeatability of Y-axis  | $E_{YY,R}$             | 0,011  | 0,014  | 0,017  |                           |
| Mean reversal value of Y-axis   | $E_{YY,Bmean}$         | 0,005  | 0,006  | 0,008  |                           |
| Bi-directional systematic positioning error of Y-axis <sup>a</sup>  | $E_{YY,E}$             | 0,008  | 0,011  | 0,013  |                           |
| Mean bi-directional positioning error of Y-axis <sup>a</sup>  | $E_{YY,M}$             | 0,003  | 0,005  | 0,006  |                           |
| Axes exceeding 2 000  |                        |  |        |        |                           |
| One or more segments of 2 000 with five runs upwards and downwards each.  |                        |  |        |        |                           |
| For axes up to 4 000, one full measurement over one 2 000 mm segment is recommended, for axes over 4 000 and up to 8 000, two 2 000 mm segments are recommended and so forth. Test segments shall be equally spaced along the full axis length, with any excess length equally divided at the beginning, in between, and at the end of the test segments. |                        |  |        |        |                           |
| Bidirectional systematic positioning error of Y-axis <sup>a</sup>   | $E_{YY,E}$             | 0,016 + 0,006 for each additional 1 000  |        |        |                           |
| Mean bi-directional positioning error of Y-axis <sup>a</sup>  | $E_{YY,M}$             | 0,008 + 0,003 for each additional 1 000  |        |        |                           |
| <sup>a</sup> May provide a basis for machine acceptance.  |                        |  |        |        |                           |
| <b>Measuring instruments</b>  |                        |  |        |        |                           |
| Laser measurement equipment or linear scale   |                        |  |        |        |                           |
| <b>Observations and references to ISO 230-2:2014, Clause 3, 5.3.2 and 5.3.3</b>   |                        |  |        |        |                           |
| The linear scale or the beam of the laser measurement equipment shall be set parallel to the travelling axis.   |                        |  |        |        |                           |
| Positioning feed speed shall be agreed between manufacturer/supplier and user.  |                        |  |        |        |                           |
| The position of the starting point of measurement shall be stated.  |                        |  |        |        |                           |
| Number and position of 2 000 test segment(s) shall be stated in the test report.  |                        |  |        |        |                           |

**Object** **P3**

Checking of accuracy and repeatability of positioning of the ram movement (Z-axis) by numerical control,  $E_{ZZ}$ .

**Diagram**

**Key**

- 1 laser head
- 2 interferometer
- 3 reflector

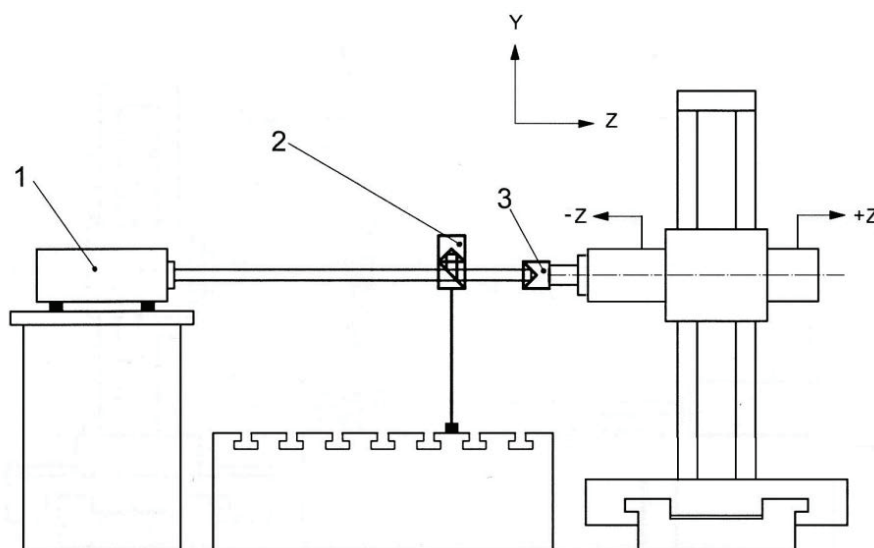

| Tolerance  |                        | Measured length |        |        | Measured deviation |
|--|------------------------|-----------------|--------|--------|--------------------|
|  |                        | ≤500            | ≤1 000 | ≤2 000 |                    |
| Bi-directional positioning accuracy of Z-axis <sup>a</sup>         | $E_{ZZA}$              | 0,014           | 0,020  | 0,022  |                    |
| Unidirectional positioning repeatability of Z-axis <sup>a</sup>    | $E_{ZZ,R↑}; E_{ZZ,R↓}$ | 0,007           | 0,009  | 0,011  |                    |
| Bi-directional positioning repeatability of Z-axis                 | $E_{ZZ,R}$             | 0,011           | 0,014  | 0,017  |                    |
| Mean reversal value of Z-axis                                      | $E_{ZZ,Bmean}$         | 0,005           | 0,006  | 0,008  |                    |
| Bi-directional systematic positioning error of Z-axis <sup>a</sup> | $E_{ZZ,E}$             | 0,008           | 0,011  | 0,013  |                    |
| Mean bi-directional positioning error of Z-axis <sup>a</sup>       | $E_{ZZ,M}$             | 0,003           | 0,005  | 0,006  |                    |

<sup>a</sup> May provide a basis for machine acceptance.

**Measuring instruments**

Laser measurement equipment or linear scale

**Observations and references to ISO 230-2:2014, Clause 3, 5.3.2 and 5.3.3**

The linear scale or the beam of the laser measurement equipment shall be set parallel to the travelling axis.

Positioning feed speed shall be agreed between manufacturer/supplier and user.

The position of the starting point of measurement shall be stated.

Number and position of 2 000 test segment(s) shall be stated in the test report.



**Object** **P4**

Checking of accuracy and repeatability of positioning of the sliding boring spindle movement (*W*-axis) by numerical control,  $E_{ZW}$ .

**Diagram**

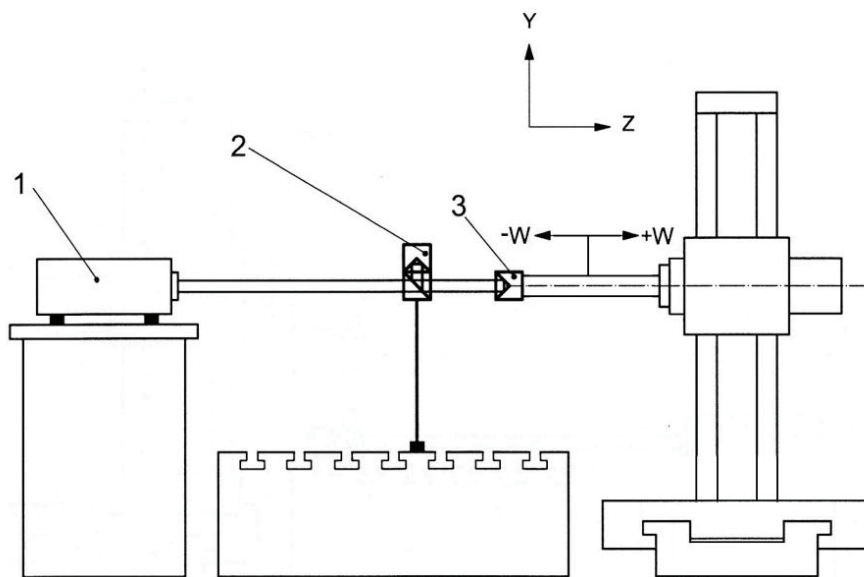

**Key**

- 1 laser head
- 2 interferometer
- 3 reflector

|  | Tolerance                              | Measured length |        | Measured deviation |
|--|--|-----------------|--------|--------------------|
|  |  | ≤500            | ≤1 000 |                    |
| Bi-directional positioning accuracy of <i>W</i> -axis <sup>a</sup>         | $E_{ZW,A}$                             | 0,017           | 0,022  |                    |
| Unidirectional positioning repeatability of <i>W</i> -axis <sup>a</sup>    | $E_{ZW,R\uparrow}; E_{ZW,R\downarrow}$ | 0,007           | 0,011  |                    |
| Bi-directional positioning repeatability of <i>W</i> -axis                 | $E_{ZW,R}$                             | 0,014           | 0,017  |                    |
| Mean reversal value of <i>W</i> -axis                                      | $E_{ZW,Bmean}$                         | 0,006           | 0,008  |                    |
| Bi-directional systematic positioning error of <i>W</i> -axis <sup>a</sup> | $E_{ZW,E}$                             | 0,010           | 0,012  |                    |
| Mean bi-directional positioning error of <i>W</i> -axis <sup>a</sup>       | $E_{ZW,M}$                             | 0,004           | 0,005  |                    |

<sup>a</sup> May provide a basis for machine acceptance.

**Measuring instruments**

Laser measurement equipment or linear scale

**Observations and references to ISO 230-2:2014, Clause 3, 5.3.2 and 5.3.3**

The linear scale or the beam of the laser measurement equipment shall be set parallel to the travelling axis.

Positioning feed speed shall be agreed between manufacturer/supplier and user.

The position of the starting point of measurement shall be stated.

|  |                        |                        |        |        |   |
|--|------------------------|------------------------|--------|--------|---|
| <b>Object</b>  |                        |                        |        |        | <b>P5</b>                                       |
| Checking of accuracy and repeatability of positioning of the table slide movement (R'-axis) by numerical control, $E_{ZR}$ . |                        |                        |        |        |   |
| <b>Diagram</b>   |                        |                        |        |        | <b>Key</b>                                      |
|  |                        |                        |        |        | 1 laser head<br>2 interferometer<br>3 reflector |
| <b>Tolerance</b>   |                        | <b>Measured length</b> |        |        | <b>Measured deviation</b>                       |
|  |                        | ≤500                   | ≤1 000 | ≤2 000 |   |
| Bi-directional positioning accuracy of R-axis <sup>a</sup>   | $E_{ZR,A}$             | 0,014                  | 0,020  | 0,022  |   |
| Unidirectional positioning repeatability of R-axis <sup>a</sup>  | $E_{ZR,R1}; E_{ZR,R2}$ | 0,007                  | 0,009  | 0,011  |   |
| Bi-directional positioning repeatability of R-axis   | $E_{ZR,R}$             | 0,011                  | 0,014  | 0,017  |   |
| Mean reversal value of R-axis  | $E_{ZR,Bmean}$         | 0,005                  | 0,006  | 0,008  |   |
| Bi-directional systematic positioning error of R-axis <sup>a</sup>   | $E_{ZR,E}$             | 0,008                  | 0,011  | 0,013  |   |
| Mean bi-directional positioning error of R-axis <sup>a</sup>   | $E_{ZR,M}$             | 0,003                  | 0,005  | 0,006  |   |
| <sup>a</sup> May provide a basis for machine acceptance.   |                        |                        |        |        |   |
| <b>Measuring instruments</b>   |                        |                        |        |        |   |
| Laser measurement equipment or linear scale  |                        |                        |        |        |   |
| <b>Observations and references to ISO 230-2:2014, Clause 3, 5.3.2 and 5.3.3</b>  |                        |                        |        |        |   |
| The linear scale or the beam of the laser measurement equipment shall be set parallel to the travelling axis.                |                        |                        |        |        |   |
| Positioning feed speed shall be agreed between manufacturer/supplier and user.   |                        |                        |        |        |   |
| The position of the starting point of measurement shall be stated.   |                        |                        |        |        |   |

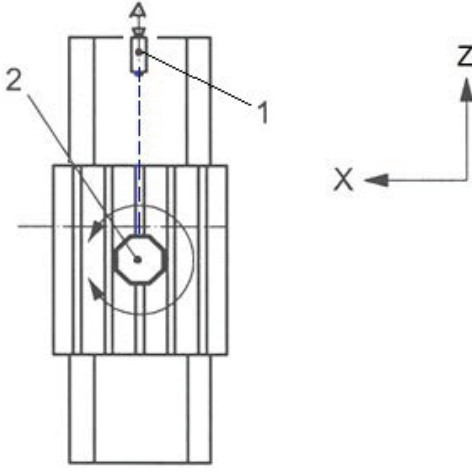
|   |                        |                 |  |                           |
|---|------------------------|-----------------|--|---------------------------|
| <b>Object</b>   |                        |                 |  | <b>P6</b>                 |
| Checking of accuracy and repeatability of angular positioning of rotary table by numerical control (B'-axis), $E_{BB}$ :<br>a) rotary table with fixed indexing positions;<br>b) rotary table capable of any angle positioning. |                        |                 |  |                           |
| <b>Diagram</b>  |                        |                 | <b>Key</b>   |                           |
|   |                        |                 | 1 autocollimator on spindle side<br>2 polygon mirror |                           |
| <b>Tolerance</b><br>(30° or 45° interval positioning)   |                        | <b>For 360°</b> |  | <b>Measured deviation</b> |
|   |                        | a)              | b)   |                           |
| Bi-directional positioning accuracy of B-axis <sup>a</sup>  | $E_{BB,A}$             | 7"              | 11"  |                           |
| Unidirectional positioning repeatability of B-axis <sup>a</sup>   | $E_{BB,R↑}; E_{BB,R↓}$ | 4"              | 6"   |                           |
| Bi-directional positioning repeatability of B-axis  | $E_{BB,R}$             | 6"              | 8"   |                           |
| Mean reversal value of B-axis   | $E_{BB,Bmean}$         | 4"              | 6"   |                           |
| Bi-directional systematic positioning error of B-axis <sup>a</sup>  | $E_{BB,E}$             | 4"              | 6"   |                           |
| Mean bi-directional positioning error of B-axis <sup>a</sup>  | $E_{BB,M}$             | 2"              | 4"   |                           |
| <sup>a</sup> May provide a basis for machine acceptance.  |                        |                 |  |                           |
| <b>Measuring instruments</b>  |                        |                 |  |                           |
| Polygon and autocollimator or laser measuring equipment   |                        |                 |  |                           |
| <b>Observations and references to ISO 230-2:2014, Clause 3, 5.3.4 and 5.3.5</b>   |                        |                 |  |                           |
| Fix the autocollimator on the spindle side of the machine and fix the polygon near to the centre of the table in alignment with the autocollimator at the first measuring rotary position.                                      |                        |                 |  |                           |
| If the movement of the rotary table does not cause any movement between the ram and a fixed part of the machine tool, the autocollimator may be fixed on the fixed part of the machine tool.                                    |                        |                 |  |                           |
| Target positions shall be selected according to ISO 230-2:2014, Table 1.  |                        |                 |  |                           |
| Angular positioning feed speed shall be agreed between manufacturer/supplier and user.  |                        |                 |  |                           |

## Annex A (informative)

### Geometric accuracy of axis of rotation

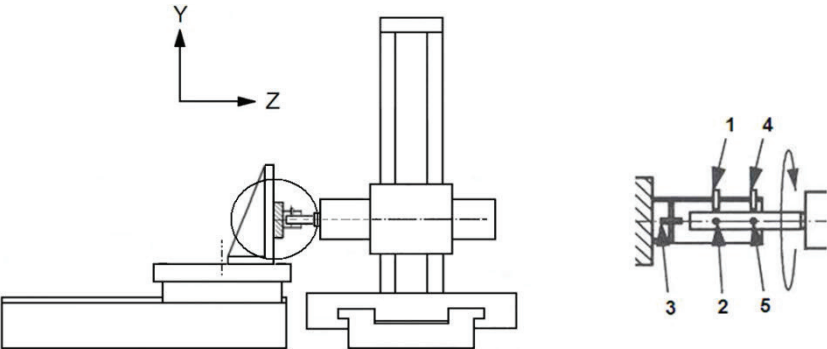
|   |                                  |
|---|----------------------------------|
| <p><b>Object</b></p> <p>Axis of rotation error motions for tool holding spindle(s) (C):</p> <p>a) radial error motion <math>E_{\text{Radial}(C)}</math>;</p> <p>b) axial error motion <math>E_{Z(C)}</math>;</p> <p>c) tilt error motion <math>E_{\text{Tilt}(C)}</math>.</p> <p>This test shall be carried out for milling and boring spindles.</p> <p>NOTE The boring spindle is retracted during the test, where applicable.</p>   | <p><b>AR1</b></p>                |
| <p><b>Diagram</b></p>   |                                  |
| <p><b>Key</b></p> <p>1, 2, 3, 4 and 5      non-contacting linear displacement sensor</p>  |                                  |
| <p><b>Tolerance<sup>a</sup></b></p> <p style="text-align: center;">At percentage of maximum speed</p> <p style="text-align: center;">10 %   50 %   100 %</p> <p>a) total radial error motion value <math>E_{\text{Radial}(C)}</math></p> <p>b) total axial error motion value <math>E_{Z(C)}</math></p> <p>c) total tilt error motion value <math>E_{\text{Tilt}(C)}</math></p> <p>NOTE If the minimum speed is greater than 10 % of the maximum speed, then the spindle should be operated at minimum speed instead.</p> <p>Different spindle speeds may be selected based on mutual agreement between the manufacturer/supplier and the user.</p> <p><sup>a</sup> If the supplier/manufacturer and the user would decide, by mutual agreement, to include this test in the contractual machine acceptance procedures, then they should also define, by mutual agreement, the corresponding tolerances to be applied. A future edition of this part of ISO 3070 may provide tolerances for this test when solid data from such measurements for spindle performance in industrial environment are available.</p> | <p><b>Measured deviation</b></p> |
| <p><b>Measuring instruments</b></p> <p>Test mandrel and non-contacting probes or two precision spheres located slightly eccentric to spindle average line and non-contacting probes</p>   |                                  |

### Observations and references to ISO 230-7

This test is a spindle test with rotating sensitive direction (ISO 230-7:2015, 5.4).

After set up of the measuring instrument, the spindle shall be warmed up at 50 % of the maximum spindle speed for a time period of 10 min, if not otherwise agreed between manufacturer/supplier and user.

Total error motion is defined in ISO 230-7:2015, 3.2.4, total error motion value in ISO 230-7:2015, 3.5.1.

- a) total radial error motion value  $E_{\text{Radial}(C)}$  (using probes 4 and 5)

Radial error motion measurement is described in ISO 230-7:2015, 5.4.2. The radial error motion shall be measured as close as possible to the spindle nose (sensors 4 and 5 in the diagram of this test).

For the radial error motion  $E_{\text{Radial}(C)}$ , a total error motion polar plot (ISO 230-7:2015, 3.3.1) with a least squares circle (LSC) centre (ISO 230-7:2015, 3.4.3) shall be provided.

- b) total axial error motion value  $E_{Z(C)}$  (using probe 3)

Axial error motion measurement is described in ISO 230-7:2015, 5.4.4.

For the axial error motion  $E_{Z(C)}$ , a total error motion polar plot (ISO 230-7:2015, 3.3.1) with a polar chart (PC) centre (ISO 230-7:2015, 3.4.1) shall be provided.

- c) total tilt error motion values  $E_{\text{Tilt}(C)}$  (using probes 1,2,4,5)

Tilt error motion measurement is described in ISO 230-7:2015, 5.4.3. The tilt error motion can be also be checked with just two non-contacting probes (see ISO 230-7:2015, 5.4.3.1 and 5.4.3.2).

For the tilt error motion  $E_{\text{Tilt}(C)}$ , total error motion polar plot (ISO 230-7:2015, 3.3.1) with a polar chart (PC) centre (ISO 230-7:2015, 3.4.1) shall be provided.

For these tests, the following parameters shall be stated:

- the radial, axial or face locations at which the measurements are made;
- identification of all artefacts, targets and fixtures used;
- the location of the measurement setup;
- the position of any linear or rotary positioning stages that are connected to the device under test;
- the direction angle of the sensitive direction, e.g. axial, radial or intermediate angles as appropriate;
- presentation of the measurement result, for example: error motion value, polar plot, time based plot, frequency content plot;
- the rotational speed of the spindle (zero for static error motion);
- the time duration in seconds or number of spindle rotations;
- appropriate warm up or break-in procedure;
- the frequency response of the instrumentation, given as hertz or cycles per rev, including roll off characteristics of any electronic filters; in the case of digital instrumentation, the displacement resolution and sampling rate;
- the structural loop, including the position and orientation of sensors relative to the spindle housing from which the error motion is reported, specified objects with respect to which the spindle axes and the reference coordinate axes are located and the elements connecting these objects;
- time and date of measurement;
- type and calibration status of all measurement instrumentation;
- other operating conditions which may influence the measurement such as ambient temperature.

If the tilt measurements are not needed (by agreement between the supplier and the user), then only three displacement sensors are used (3, 4, and 5) and test mandrel may be replaced by precision test sphere.

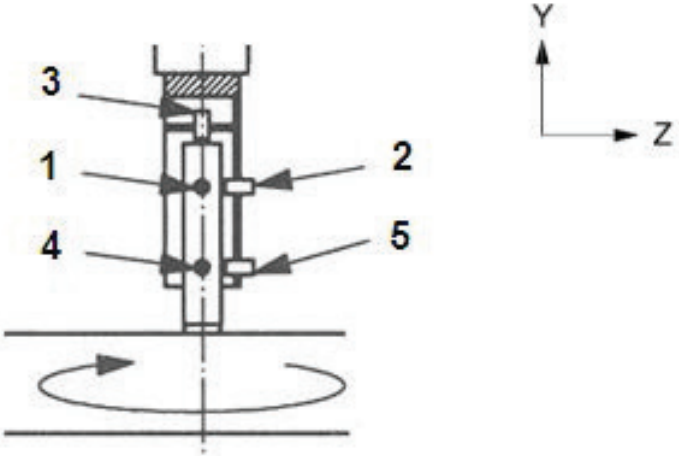
|  |                                  |
|--|----------------------------------|
| <p><b>Object</b></p> <p>Axis of rotation error motion for work holding table:</p> <p>a) radial error motion <math>E_{\text{Radial B}}</math>;<br/>             b) axial error motion <math>E_{\text{YB}}</math>;<br/>             c) tilt error motion <math>E_{\text{Tilt B}}</math>.</p>   | <p>AR2</p>                       |
| <p><b>Diagram</b></p>    |                                  |
| <p><b>Key</b></p> <p>1, 2, 3, 4 and 5      non-contacting linear displacement sensor</p>   |                                  |
| <p><b>Tolerance<sup>a</sup></b></p> <p style="text-align: center;">At percentage of maximum speed</p> <p style="text-align: center;">10 %   50 %   100 %</p> <p>a) Total radial error motion value <math>E_{\text{Radial B}}</math><br/>             b) Total axial error motion value <math>E_{\text{YB}}</math><br/>             c) Total tilt error motion value <math>E_{\text{Tilt B}}</math></p> <p>NOTE If the minimum speed is larger than 10 % of the maximum speed, then the table should be operated at minimum speed instead. Different spindle speeds may be selected based on mutual agreement between the manufacturer/supplier and the user.</p> <p><sup>a</sup> If the supplier/manufacturer and the user would decide, by mutual agreement, to include this test in the contractual machine acceptance procedures, then they should also define, by mutual agreement, the corresponding tolerances to be applied. A future edition of this part of ISO 3070 may provide tolerances for this test when solid data from such measurements for spindle performance in industrial environment are available.</p> | <p><b>Measured deviation</b></p> |
| <p><b>Measuring instruments</b></p> <p>Test mandrel and non-contacting probes or two precision spheres located slightly eccentric to spindle average line and non-contacting probes</p>  |                                  |

#### Observations and references to ISO 230-7

This test is a test with fixed sensitive direction (ISO 230-7:2015, 5.5).

If the table can be used for turning operations, after set up of the measuring instrument, the table shall be warmed up at 50 % of the maximum table speed for a time period of 10 min, if not otherwise agreed between manufacturer/supplier and user.

Total error motion and total error motion value are defined in ISO 230-7:2015, 3.2.4 and 3.5.1, respectively.

a) Total radial error motion value  $E_{\text{Radial B}}$  (using probes 4 and 5)

Radial error motion measurement is described in ISO 230-7:2015, 5.5.3. The radial error motion shall be measured as close as possible to the table surface (sensors 4 and 5 in the diagram).

For the radial error motion  $E_{\text{Radial B}}$ , a total error motion polar plot (ISO 230-7:2015, 3.3.1) with a least squares circle (LSC) centre (ISO 230-7:2015, 3.4.3) shall be provided.

b) Total axial error motion value  $E_{\text{YB}}$  (using probe 3)

Axial error motion measurement is described in ISO 230-7:2015, 5.4.4.

For the axial error motion  $E_{\text{YB}}$ , a total error motion polar plot (ISO 230-7:2015, 3.3.1) with a polar chart (PC) centre (ISO 230-7:2015, 3.4.1) shall be provided.

c) Total tilt error motion values  $E_{\text{Tilt B}}$  (using probes 1,2,4,5)

Tilt error motion measurement is described in ISO 230-7:2015, 5.5.5. Any tilt error motion can be also checked with just one non contacting probe (see ISO 230-7:2015, 5.5.5.2 and 5.5.5.4).

For the tilt error motion  $E_{\text{Tilt B}}$ , a total error motion polar plot (ISO 230-7:2015, 3.3.1) with a polar chart (PC) centre (ISO 230-7:2015, 3.4.1) shall be provided.

For these tests, the following parameters shall be stated:

- the radial, axial or face locations at which the measurements are made;
- identification of all artefacts, targets and fixtures used;
- the location of the measurement setup;
- the position of any linear or rotary positioning stages that are connected to the device under test;
- the direction angle of the sensitive direction, e.g. axial, radial or intermediate angles, as appropriate;
- presentation of the measurement result, for example: error motion value, polar plot, time based plot, frequency content plot;
- the rotational speed of the table (zero for static error motion);
- the time duration in seconds or number of table rotations;
- appropriate warm up or break-in procedure;
- the frequency response of the instrumentation, given as hertz or cycles per rev, including roll off characteristics of any electronic filters; in the case of digital instrumentation, the displacement resolution and sampling rate;
- the structural loop, including the position and orientation of sensors relative to the table housing from which the error motion is reported, specified objects with respect to which the table axes and the reference coordinate axes are located and the elements connecting these objects;
- time and date of measurement;
- type and calibration status of all measurement instrumentation;
- other operating conditions which may influence the measurement such as ambient temperature.

If the tilt measurements are not needed (by agreement between the supplier and the user), then only three displacement sensors are used (3, 4, and 5) and test mandrel may be replaced by precision test sphere.

## Annex B (normative)

### Tests of accessory facing heads [see [Figure 2 b](#)]

|   |            |
|---|------------|
| <b>Object</b>   | <b>BG1</b> |
| Checking of squareness between the facing head rotation axis and the X-axis.  |            |
| <b>Diagram</b>  |            |
|   |            |
| <b>Tolerance</b>  | 0,03/1 000 |
| <b>Measured deviation</b>   |            |
| <b>Measuring instruments</b>  |            |
| Dial gauge, special arm and cross-square  |            |
| <b>Observations and references to ISO 230-1, 5.512.1 and 5.512.32</b>   |            |
| Z-axis to be locked, if possible.   |            |
| Fix a linear displacement sensor to the facing head by means of a special arm, stiff enough so as to prevent any possible reading errors due to its opposite deflections in the two measurement positions.  |            |
| Place the stylus of the linear displacement sensor against the cross-square. Zero the linear displacement sensor. Turn the facing head and move the X-axis until the stylus touches again the cross-square in the same point. Record the reading. |            |
| The difference between the two readings divided by the distance travelled by the X-axis is the required deviation.  |            |
| Value and sign of the deviation shall be noted.   |            |

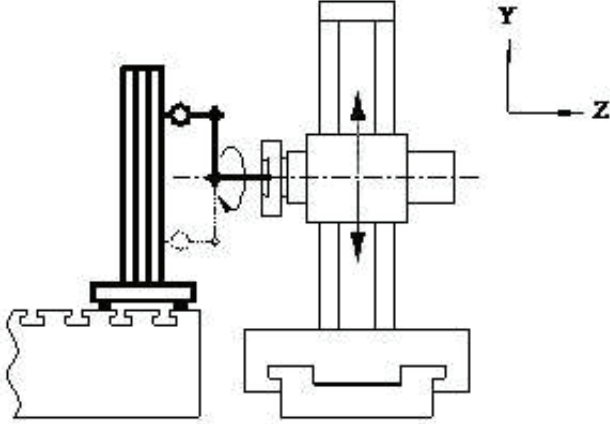

|   |            |
|---|------------|
| <b>Object</b>   | <b>BG2</b> |
| Checking of squareness between the facing head rotation axis and the Y-axis.  |            |
| <b>Diagram</b>    |            |
| <b>Tolerance</b> <p style="text-align: center;">0,03/1 000</p>  |            |
| <b>Measured deviation</b>   |            |
| <b>Measuring instruments</b>  |            |
| Cylindrical square, surface plate, adjustable blocks, dial gauge and special arm.   |            |
| <b>Observations and references to ISO 230-1, 5.512.1 and 5.512.32</b>   |            |
| <p>Z-axis to be locked, if possible.</p> <p>Set a surface plate on the table, then place a square on it. Adjust the surface plate until the square is parallel to the Y-axis by using adjustable blocks or the lack of parallelism shall be considered in the measurement.</p> <p>Fix a linear displacement sensor to the facing head by means of a special arm, stiff enough so as to prevent any possible reading errors due to its opposite deflections in the two measurement positions.</p> <p>Place the stylus of the linear displacement sensor against the square. Zero the linear displacement sensor. Turn the facing head until the stylus touches again the square. Record the reading.</p> <p>The difference between the two readings divided by the distance between the two measuring points is the measured deviation.</p> <p>Value and sign of the deviation shall be noted.</p> |            |

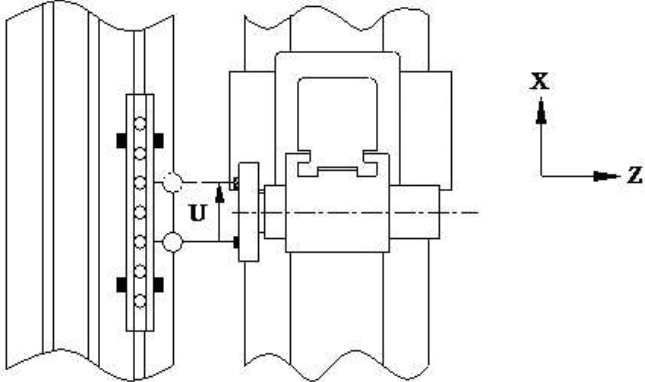
|  |                                  |
|--|----------------------------------|
| <b>Object</b>  | <b>BG3</b>                       |
| Checking of squareness between the radial facing slide movement (U-axis) and the facing head rotation axis.  |                                  |
| <p><b>Diagram</b></p>    |                                  |
| <p><b>Tolerance</b></p> <p style="text-align: center;">0,025 for a measuring length of 300</p>   | <p><b>Measured deviation</b></p> |
| <p><b>Measuring instruments</b></p> <p>Straightedge, dial gauge and gauge blocks.</p>  |                                  |
| <p><b>Observations and references to ISO 230-1, 5.422.5 and 5.422.2</b></p> <p>Z-axis to be locked, if possible.</p> <p>Set a straightedge horizontally on the table. Fix a linear displacement sensor to the radial facing slide with the stylus against the straightedge. Adjust the straightedge perpendicular to the axis of rotation of the head by rotating the head over 180° until the same reading is obtained at both sides, without moving the radial facing slide (U-axis). Zero the linear displacement sensor.</p> <p>Move the radial facing slide (U-axis) along its travel and record the difference between the readings at both ends of the travel. This difference, divided by the U-axis travel length, is the required deviation.</p> |                                  |

**Object** **BP1**  
Checking of accuracy and repeatability of positioning of the radial facing slide movement (U-axis) by numerical control.

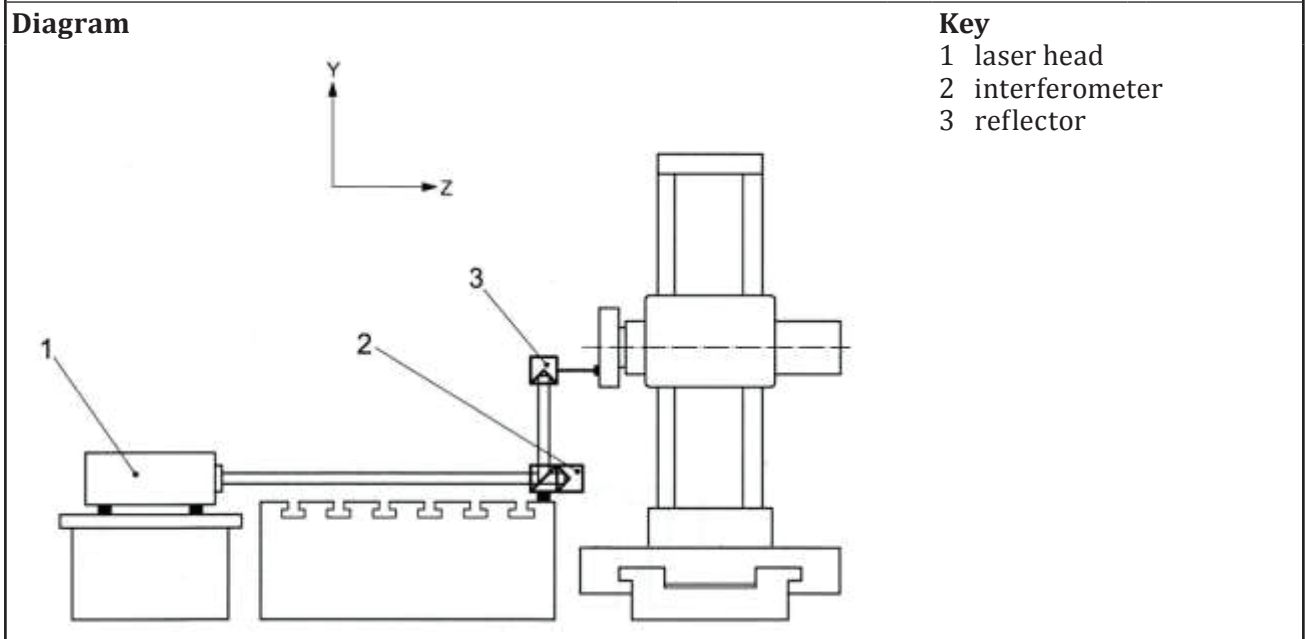

| Tolerance  |  | Measured length | Measured deviation |
|--|--|-----------------|--------------------|
|  |  | ≤500            |                    |
| Bi-directional positioning accuracy of U-axis <sup>a</sup>         | $E_{XU,A}$                                 | 0,014           |                    |
| Unidirectional positioning repeatability of U-axis <sup>a</sup>    | $E_{XU,R\uparrow}$ or $E_{XU,R\downarrow}$ | 0,007           |                    |
| Bi-directional positioning repeatability of U-axis                 | $E_{XU,R}$                                 | 0,011           |                    |
| Mean reversal value of U-axis                                      | $E_{XU,Bmean}$                             | 0,005           |                    |
| Bi-directional systematic positioning error of U-axis <sup>a</sup> | $E_{XU,E}$                                 | 0,007           |                    |
| Mean bi-directional positioning error of U-axis <sup>a</sup>       | $E_{XU,M}$                                 | 0,003           |                    |

<sup>a</sup> May provide a basis for machine acceptance.

**Measuring instruments**

Laser measurement equipment or linear scale

**Observations and references to ISO 230-2, 4.3.2**

Linear scale or axis of the beam of laser measurement equipment is to be set parallel to travelling axis.

Rapid feed is used for positioning in principle, but arbitrary feed rate can be used in agreement between manufacturer/supplier and user.

The position of starting point of measurement shall be stated.

## Annex C (informative)

### Nomenclature of machine tool components in other languages

See Tables C.1 and C.2.

**Table C.1 — Nomenclature of components depicted in [Figure 1](#)**

| <a href="#">Figure 1</a><br>ref. | English             | Italian             | Persian          |
|----------------------------------|---------------------|---------------------|------------------|
| 1                                | bed                 | banco               | رتسب             |
| 2                                | column base         | base del montante   | نوتس هياپ        |
| 3                                | spindle head        | testa               | لدن يپسا يگلک    |
| 4                                | ram                 | slittone            | مار              |
| 5                                | column              | montante            | نوتس             |
| 6                                | spindle             | mandrino            | لدن يپسا         |
| 7                                | fixed table         | tavola fissa        | تبات زي          |
| 8                                | table bed           | banco della tavola  | زي م رتسب        |
| 9                                | rotary table saddle | slitta della tavola | راود زي م تروپاس |
| 10                               | rotary table        | tavola girevole     | راود زي م        |

NOTE In addition to the terms used in the three ISO official languages provided in [Table 1](#), this table provides the equivalent terms in Italian and Persian; these are published under the responsibility of the member body for Italy (UNI) and Iran (ISIRI) and are given for information only. Only the terms given in the official languages can be considered as ISO terms.

**Table C.2 — Nomenclature of components depicted in [Figure 2](#)**

| <a href="#">Figure 2</a><br>ref. | English                    | Italian                     | Persian                              |
|----------------------------------|----------------------------|-----------------------------|--------------------------------------|
| 1                                | boring spindle             | mandrino di alesatura       | شارت خاروس لدن يپسا                  |
| 2                                | milling spindle            | mandrino di fresatura       | زرف لدن يپسا                         |
| 3                                | facing head                | testa a sfacciare           | شارت ي ن اش يپ يگلک                  |
| 4                                | headstock with facing head | testa con testa a sfacciare | يگلک اب يگلک هوم ج م شار ت ي ن اش يپ |
| 5                                | ram                        | slittone                    | مار                                  |

NOTE In addition to the terms used in the three ISO official languages provided in [Table 2](#), this table provides the equivalent terms in Italian and Persian; these are published under the responsibility of the member body for Italy (UNI) and Iran (ISIRI) and are given for information only. Only the terms given in the official languages can be considered as ISO terms.

## Bibliography

- [1] ISO 230-3, *Test code for machine tools — Part 3: Determination of thermal effects*
- [2] ISO/TR 230-11, *Test code for machine tools — Part 11: Measuring instruments suitable for machine tool geometry tests*
- [3] ISO 841, *Industrial automation systems and integration — Numerical control of machines — Coordinate system and motion nomenclature*
- [4] ISO 3070-1:2007, *Machine tools — Test conditions for testing the accuracy of boring and milling machines with horizontal spindle — Part 1: Machines with fixed column and movable table*
- [5] ISO 3070-3:2007, *Machine tools — Test conditions for testing the accuracy of boring and milling machines with horizontal spindle — Part 3: Machines with movable column and movable table*
- [6] ISO 10791-7, *Test conditions for machining centres — Part 7: Accuracy of finished test piece*
- [7] ISO 10791-10, *Test conditions for machining centres — Part 10: Evaluation of thermal distortions*
- [8] ISO 17543-1, *Machine tools — Test conditions for accessory spindle heads — Part 1: Horizontal spindle machines*
- [9] ISO/TR 16907, *Machine tools — Numerical compensation of geometric errors*
- [10] DIN 876-2, *Surface plates — Cast iron surface plates — Requirements and testing*
- [11] ESTLER W. T., EDMUNDSON K. L., PEGGS G. N., PARKER D. H. *Large scale metrology - Un update - Annals of the CIRP, 51/2/2002, page 587*





# British Standards Institution (BSI)

BSI is the national body responsible for preparing British Standards and other standards-related publications, information and services.

BSI is incorporated by Royal Charter. British Standards and other standardization products are published by BSI Standards Limited.

## About us

We bring together business, industry, government, consumers, innovators and others to shape their combined experience and expertise into standards-based solutions.

The knowledge embodied in our standards has been carefully assembled in a dependable format and refined through our open consultation process. Organizations of all sizes and across all sectors choose standards to help them achieve their goals.

## Information on standards

We can provide you with the knowledge that your organization needs to succeed. Find out more about British Standards by visiting our website at [bsigroup.com/standards](http://bsigroup.com/standards) or contacting our Customer Services team or Knowledge Centre.

## Buying standards

You can buy and download PDF versions of BSI publications, including British and adopted European and international standards, through our website at [bsigroup.com/shop](http://bsigroup.com/shop), where hard copies can also be purchased.

If you need international and foreign standards from other Standards Development Organizations, hard copies can be ordered from our Customer Services team.

## Copyright in BSI publications

All the content in BSI publications, including British Standards, is the property of and copyrighted by BSI or some person or entity that owns copyright in the information used (such as the international standardization bodies) and has formally licensed such information to BSI for commercial publication and use.

Save for the provisions below, you may not transfer, share or disseminate any portion of the standard to any other person. You may not adapt, distribute, commercially exploit, or publicly display the standard or any portion thereof in any manner whatsoever without BSI's prior written consent.

## Storing and using standards

Standards purchased in soft copy format:

- A British Standard purchased in soft copy format is licensed to a sole named user for personal or internal company use only.
- The standard may be stored on more than 1 device provided that it is accessible by the sole named user only and that only 1 copy is accessed at any one time.
- A single paper copy may be printed for personal or internal company use only.

Standards purchased in hard copy format:

- A British Standard purchased in hard copy format is for personal or internal company use only.
- It may not be further reproduced – in any format – to create an additional copy. This includes scanning of the document.

If you need more than 1 copy of the document, or if you wish to share the document on an internal network, you can save money by choosing a subscription product (see 'Subscriptions').

## Reproducing extracts

For permission to reproduce content from BSI publications contact the BSI Copyright & Licensing team.

## Subscriptions

Our range of subscription services are designed to make using standards easier for you. For further information on our subscription products go to [bsigroup.com/subscriptions](http://bsigroup.com/subscriptions).

With **British Standards Online (BSOL)** you'll have instant access to over 55,000 British and adopted European and international standards from your desktop. It's available 24/7 and is refreshed daily so you'll always be up to date.

You can keep in touch with standards developments and receive substantial discounts on the purchase price of standards, both in single copy and subscription format, by becoming a **BSI Subscribing Member**.

**PLUS** is an updating service exclusive to BSI Subscribing Members. You will automatically receive the latest hard copy of your standards when they're revised or replaced.

To find out more about becoming a BSI Subscribing Member and the benefits of membership, please visit [bsigroup.com/shop](http://bsigroup.com/shop).

With a **Multi-User Network Licence (MUNL)** you are able to host standards publications on your intranet. Licences can cover as few or as many users as you wish. With updates supplied as soon as they're available, you can be sure your documentation is current. For further information, email [subscriptions@bsigroup.com](mailto:subscriptions@bsigroup.com).

## Revisions

Our British Standards and other publications are updated by amendment or revision.

We continually improve the quality of our products and services to benefit your business. If you find an inaccuracy or ambiguity within a British Standard or other BSI publication please inform the Knowledge Centre.

## Useful Contacts

### Customer Services

**Tel:** +44 345 086 9001

**Email (orders):** [orders@bsigroup.com](mailto:orders@bsigroup.com)

**Email (enquiries):** [cservices@bsigroup.com](mailto:cservices@bsigroup.com)

### Subscriptions

**Tel:** +44 345 086 9001

**Email:** [subscriptions@bsigroup.com](mailto:subscriptions@bsigroup.com)

### Knowledge Centre

**Tel:** +44 20 8996 7004

**Email:** [knowledgecentre@bsigroup.com](mailto:knowledgecentre@bsigroup.com)

### Copyright & Licensing

**Tel:** +44 20 8996 7070

**Email:** [copyright@bsigroup.com](mailto:copyright@bsigroup.com)

### BSI Group Headquarters

389 Chiswick High Road London W4 4AL UK