

# Fire resistance tests — Elements of building construction — Glazed elements

ICS 13.220.50; 81.040.20

## National foreword

This British Standard reproduces verbatim ISO 3009:2003 and implements it as the UK national standard.

The UK participation in its preparation was entrusted by Technical Committee FSH/22, Fire resistance tests, to Subcommittee FSH/22/7, Fire test procedures for partitions and walls, which has the responsibility to:

- aid enquirers to understand the text;
- present to the responsible international/European committee any enquiries on the interpretation, or proposals for change, and keep the UK interests informed;
- monitor related international and European developments and promulgate them in the UK.

A list of organizations represented on this subcommittee can be obtained on request to its secretary.

### Cross-references

The British Standards which implement international publications referred to in this document may be found in the *BSI Catalogue* under the section entitled “International Standards Correspondence Index”, or by using the “Search” facility of the *BSI Electronic Catalogue* or of British Standards Online.

This publication does not purport to include all the necessary provisions of a contract. Users are responsible for its correct application.

**Compliance with a British Standard does not of itself confer immunity from legal obligations.**

### Summary of pages

This document comprises a front cover, an inside front cover, the ISO title page, pages ii to v, a blank page, pages 1 to 26, an inside back cover and a back cover.

The BSI copyright notice displayed in this document indicates when the document was last issued.

### Amendments issued since publication

Amd. No.	Date	Comments

This British Standard was published under the authority of the Standards Policy and Strategy Committee on 13 February 2004

© BSI 13 February 2004

ISBN 0 580 43434 6

INTERNATIONAL  
STANDARD

**ISO**  
**3009**

Second edition  
2003-11-01

---

---

**Fire-resistance tests — Elements of  
building construction — Glazed elements**

*Essais de résistance au feu — Éléments de construction — Éléments  
en verre*



Reference number  
ISO 3009:2003(E)



# Contents

Page

Foreword.....	iv
Introduction .....	v
1 Scope.....	1
2 Normative references .....	1
3 Terms, definitions and symbols .....	2
4 Test equipment.....	4
5 Test conditions.....	6
6 Test specimen preparation .....	6
6.1 General .....	6
6.2 Number of specimens.....	6
6.3 Size of specimen .....	6
6.4 Test construction .....	6
7 Application of instrumentation .....	9
7.1 Furnace thermocouples (plate thermometer) .....	9
7.2 Specimen thermocouples .....	9
7.3 Furnace pressure .....	9
7.4 Heat flux measurement.....	9
7.5 Deflection measurement .....	10
8 Test procedure .....	10
8.1 Furnace control .....	10
8.2 Measurements and observations .....	11
9 Performance criteria .....	11
10 Validity of the test .....	12
11 Expression of results.....	12
12 Test report.....	12
Annex A (informative) Non-planar elements and test data application .....	14
Annex B (normative) Test specimens — Testing insulated and uninsulated glazing.....	18
Bibliography .....	26

## **Foreword**

ISO (the International Organization for Standardization) is a worldwide federation of national standards bodies (ISO member bodies). The work of preparing International Standards is normally carried out through ISO technical committees. Each member body interested in a subject for which a technical committee has been established has the right to be represented on that committee. International organizations, governmental and non-governmental, in liaison with ISO, also take part in the work. ISO collaborates closely with the International Electrotechnical Commission (IEC) on all matters of electrotechnical standardization.

International Standards are drafted in accordance with the rules given in the ISO/IEC Directives, Part 2.

The main task of technical committees is to prepare International Standards. Draft International Standards adopted by the technical committees are circulated to the member bodies for voting. Publication as an International Standard requires approval by at least 75 % of the member bodies casting a vote.

Attention is drawn to the possibility that some of the elements of this document may be the subject of patent rights. ISO shall not be held responsible for identifying any or all such patent rights.

ISO 3009 was prepared by Technical Committee ISO/TC 92, *Fire safety*, Subcommittee SC 2, *Fire containment*.

This second edition cancels and replaces the first edition (ISO 3009:1976), which has been technically revised.

## Introduction

This International Standard contains specific requirements for fire resistance testing which are unique to glazed elements used in building construction. The requirements for these glazed elements are intended to be applied, as appropriate, in conjunction with the detailed and general requirements given in ISO 834-1.





# Fire-resistance tests — Elements of building construction — Glazed elements

**SAFETY PRECAUTIONS** — The attention of all persons concerned with managing and carrying out this fire resistance test is drawn to the fact that fire testing can be hazardous and that there is a possibility that toxic and/or harmful smoke and gases could be evolved during the test. Mechanical and operational hazards can also arise during the construction of the test elements or structures, their testing, and disposal of test residues.

An assessment of all potential hazards and risks to health shall be made and safety precautions shall be identified and provided. Written safety instructions shall be issued. Appropriate training shall be given to relevant personnel. Laboratory personnel shall ensure that they follow written safety instructions at all times.

## 1 Scope

This International Standard provides a test method for determining and assessing the fire resistance performance of both insulated and uninsulated glazed elements of building construction, when those elements are exposed to heating on one face. It is applicable to glazed separating elements such as screens, walls of glass blocks and other light-transmitting assemblies used in vertical, inclined or horizontal orientations, and to all separating elements containing glazing intended to be assessed in accordance with ISO 834-1 — except for doors and shutter assemblies, which are intended to be tested in accordance with ISO 3008. It is directly applicable to planar elements, but also gives guidance on the testing of non-planar elements such as pyramids.

The application of the test results to other, untested, forms of construction is acceptable only when the construction complies with the field of direct application given in this International Standard or when it is subjected to a field of extended application analysis in accordance with ISO/TR 12470.

**NOTE** Since ISO/TR 12470 gives only general guidelines, specific extended application analyses are to be performed only by persons expert in fire-resistant constructions.

## 2 Normative references

The following referenced documents are indispensable for the application of this document. For dated references, only the edition cited applies. For undated references, the latest edition of the referenced document (including any amendments) applies.

ISO 834-1:1999, *Fire-resistance tests — Elements of building construction — Part 1: General requirements*

ISO 834-8, *Fire-resistance tests — Elements of building construction — Part 8: Specific requirements for non-loadbearing vertical separating elements*

ISO 6308, *Gypsum plasterboard — Specification*

ISO 13943, *Fire safety — Vocabulary*

### 3 Terms, definitions and symbols

For the purposes of this document, the terms and definitions given in ISO 13943, the following terms and definitions, and the symbols given in ISO 834-1, apply.

- 3.1 aspect ratio**  
ratio of the exposed height to the exposed width of the glass
- 3.2 associated construction**  
specific construction in which the glazed element is to be installed in practice and which is used to close off the furnace and provide the levels of restraint and thermal heat transfer to be experienced in normal use
- 3.3 expansion allowance**  
difference in dimension between the pane or unit and the opening/aperture in the frame or other method of attachment into which the panes or units are mounted, available for expansion

NOTE The dimensions are measured in two directions (e.g. vertical and horizontal for a vertical glazed element). See dimension  $y-x$  in Figure 1.

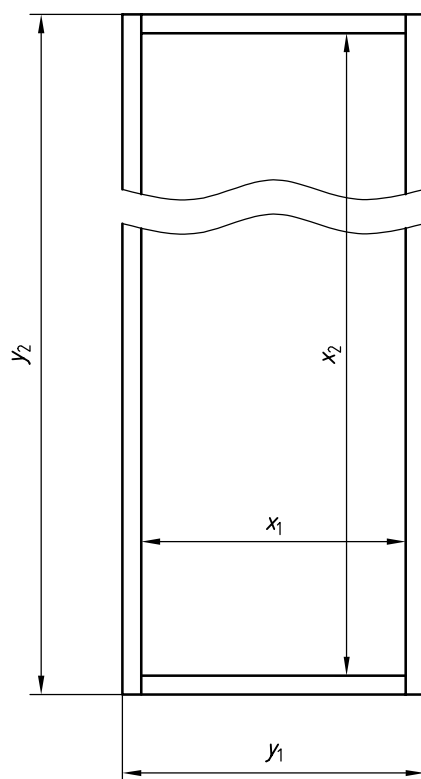

- $y_1$  aperture width
- $y_2$  aperture height
- $x_1$  visible glass width
- $x_2$  visible glass height

Figure 1 — Elevation of glazed pane

**3.4****fire-resistant gypsum board**

gypsum board with increased fire resistance as a result of additives to the formulation as specified in ISO 6308

**3.5****glass**

rigid transparent or translucent material installed in elements of construction for the purpose of vision or to allow the passage of light

**3.6****glass edge cover**

depth of glass retained by the glazing system

NOTE Half the difference between the pane dimension and the exposed dimension, assuming that the pane is centrally glazed into the opening. See dimension  $w$  in Figure 2.

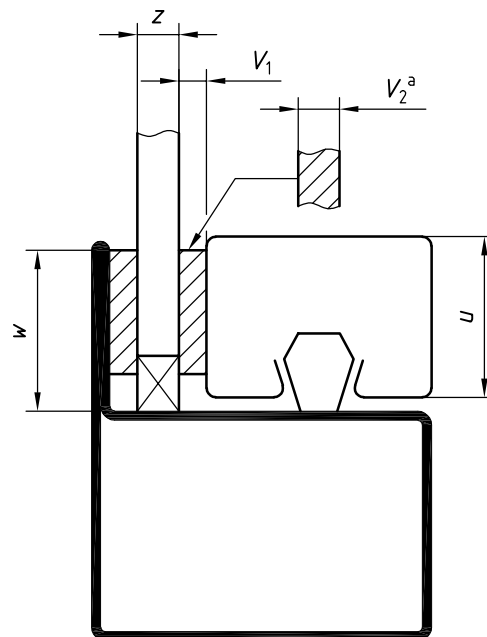

$z$  glass thickness

$w$  edge cover

$V_2$  pre-installed (for gaskets and strips)

$V_1$  post-installed (for gaskets and strips)

$u$  depth

<sup>a</sup> Uncompressed.

**Figure 2 — Cross-section through framing/glazing system**

**3.7****glazed element**

element containing transparent or translucent panes or units retained in frames or other methods of attachment or units mounted or attached together to provide a barrier

**3.8****horizontal glazed element**

glazed element intended for installations with inclinations of from  $0^\circ$  up to and including  $25^\circ$

- 3.9**  
**inclination**  
angle of installation relative to a horizontal plane (between 0° and 90°)
- 3.10**  
**inclined glazed element**  
glazed element intended for installation with inclinations of from greater than 25° up to and including 80°
- 3.11**  
**insulated glazing**  
fire-resistant glazing that satisfies both the integrity and insulation criteria for the anticipated fire-resistance period
- 3.12**  
**mullion**  
vertical framing member separating and supporting two adjacent panes of glass or panels
- 3.13**  
**orientation**  
direction of fire exposure with respect to the face of the specimen
- EXAMPLE For inclined specimens, orientation is from underneath when using a floor furnace for conducting the test.
- 3.14**  
**screen**  
vertical glazed separating element with multiple panes, which can also incorporate a door assembly
- 3.15**  
**supporting construction**  
construction that could be required for the testing of some glazed elements into which the test specimen is assembled
- EXAMPLE The wall into which a screen is fitted.
- 3.16**  
**transom**  
horizontal framing member separating and supporting two adjacent panes of glass or panels
- 3.17**  
**uninsulated glazing**  
fire-resistant glazing that satisfies the integrity of, and, where required, the radiation criteria for, the anticipated fire resistance period, but which is not intended to provide insulation
- 3.18**  
**vertical glazed element**  
glazed element intended for installation with inclinations of from greater than 80° up to and including 90°

## 4 Test equipment

The test equipment shall be as specified in ISO 834-1. The furnace used will be related to the orientation of the test specimen. For vertical specimens, the wall testing furnace is suitable; for horizontal specimens the floor furnace is applicable; for inclined specimens, either of these may be used depending upon the anticipated exposure conditions.

A test frame or supporting construction is required for the mounting or erection of the specimen. It shall be designed so that it possesses sufficient stiffness in relation to the test construction. The rigidity of the test frame shall be evaluated by applying an expansion force within the frame mid-way between two opposite members of the frame and measuring the increase in the internal dimensions at these positions. This

evaluation shall be conducted in both directions of the frame and the increase of the internal dimension shall be measured.

The increase in the internal dimensions of the test frame shall not exceed 5 mm with an applied force of 25 kN.

For tests on inclined elements, the furnace could need to be altered to allow for the test specimen's installation. In these cases, the thermal properties of the furnace extensions shall be equivalent to those of the furnace. See Figure 3 for an example of inclined sample installation.

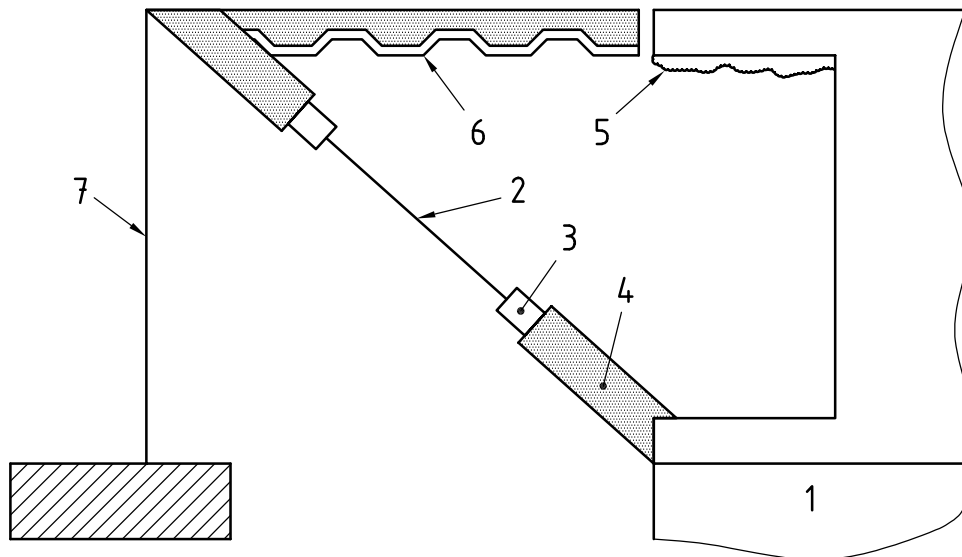

#### Key

- 1 vertical furnace
- 2 glazing
- 3 glazing frame
- 4 supporting construction
- 5 furnace lining
- 6 furnace extension
- 7 furnace extension support

NOTE The thermal properties of the furnace lining are the same as those of the furnace extension.

**Figure 3 — Inclined sample installation from above — Example**

Measurements of heat flux from the unexposed surface of a specimen shall be made by an instrument complying with the following specifications.

- The target of the instrument shall not be shielded by a window or subject to a gas purge, i.e. it shall be subject to convection as well as radiation.
- Suggested range: (0 to 50) kW/m<sup>2</sup>.
- Accuracy:  $\pm 5$  % of maximum in range.
- Time constant (time to reach 64 % of target value): < 10 s.
- View angle:  $(180 \pm 5)^\circ$ .

## 5 Test conditions

The heating and pressure conditions and furnace atmosphere shall be in accordance with ISO 834-1.

For inclined elements, the furnace shall be operated such that the pressure 100 mm below the top of the exposed face of the test specimen is  $(20 \pm 3)$  Pa.

## 6 Test specimen preparation

### 6.1 General

**6.1.1** The test specimen shall be fully representative of the construction on which information is required and as intended to be used in practice.

**6.1.2** The inclination of the specimen shall be selected according to the field of application. The orientation of the specimen shall be based on how the glazed element is to be used in practice — i.e. fire exposure from above or below.

### 6.2 Number of specimens

**6.2.1** For vertical elements, the number of specimens shall follow the general principle of ISO 834-1.

**6.2.2** For horizontal or inclined elements, tests shall be conducted with exposure from the underside, unless for inclined specimens it can be demonstrated that exposure may occur from either side, in which case both sides shall be tested (where the side of fire exposure is known, only exposure from that side is necessary).

NOTE For inclinations between  $0^\circ$  and  $45^\circ$ , fire exposure from above is not covered by this International Standard.

### 6.3 Size of specimen

For specimens tested in a vertical furnace, the specimen size shall be full-size when the construction is in practice less than 3 m high or 3 m wide. For larger elements that can be accommodated in at least a 3 m by 3 m furnace, the minimum specimen size exposed to the heating shall not be less than  $3 \text{ m} \times 3 \text{ m}$ .

For specimens tested in a horizontal furnace, the exposed dimensions of the test specimen shall be at least  $4 \text{ m} \times 3 \text{ m}$ , unless the construction it represents is designed to have exposed dimensions of less than  $4 \text{ m} \times 3 \text{ m}$ , in which case the actual size shall be tested.

### 6.4 Test construction

#### 6.4.1 General

Where the test specimen is the same size as the opening in the support/restraint frame, the specimen shall be installed directly into the specimen support/restraint frame. The method of fixing shall be appropriate to the nature of the materials used to line this specimen support/restraint frame.

Where the element is smaller than the opening in the specimen support/restraint frame, the space between the specimen and the frame shall be filled with associated or supporting construction.

#### 6.4.2 Associated construction

When the glazed construction to be tested is always installed in a specific — normally proprietary — form of construction, the specimen shall be installed in a sample of this associated construction with appropriate fixings.

### 6.4.3 Supporting construction

#### 6.4.3.1 For vertical specimens

##### 6.4.3.1.1 General (see Clause 4 for properties of furnace extensions)

If the size of the test specimen is smaller than the opening in the test frame, it shall be installed in the test frame as follows, as appropriate.

- a) Where the height of the test specimen is smaller than the height of the test frame opening, a supporting construction shall be used to reduce the opening to the required height. The supporting construction shall possess sufficient stability for the test specimen and shall be a rigid standard supporting construction such as the examples given in 6.4.3.1.2 and 6.4.3.1.3.
- b) Where the width of the test specimen is smaller, a rigid or flexible standard supporting construction shall be used on the vertical sides of the opening in accordance either with 6.4.3.1.2 to 6.4.3.1.4 or 6.4.3.1.5.

##### 6.4.3.1.2 High-density rigid construction

EXAMPLE Blockwork, masonry or homogenous concrete wall with an overall density of  $(1\,200 \pm 400)$  kg/m<sup>3</sup> and a thickness of  $(200 \pm 50)$  mm.

##### 6.4.3.1.3 Low-density rigid construction

EXAMPLE Aerated concrete block wall with an overall density of  $(650 \pm 200)$  kg/m<sup>3</sup> and a thickness  $\geq 70$  mm.

##### 6.4.3.1.4 Mortar

For blockwork (incorporating aerated concrete) or masonry wall supporting constructions such as the examples given in 6.4.3.1.2 and 6.4.3.1.3, the individual masonry units shall be bonded together with a sand, cement and water mortar in the ratio of four parts sand to one part cement.

##### 6.4.3.1.5 Flexible construction

**Lightweight gypsum board-faced steel stud partition** with components and construction as follows.

#### a) Components

- 1) **Head/floor track** — rolled steel U-track 0,5 mm to 1,5 mm thick, 67 mm to 77 mm deep.
- 2) **Studs** — rolled steel C-studs 0,5 mm to 1,5 mm thick, 65 mm to 75 mm deep.
- 3) **Linings** — paper-faced, fire-resistant gypsum board, with the number and thickness of layers to be fixed to each side of the framework:
  - i) for intended fire resistance of test specimen up to and including 30 min — one layer each 15 mm thick or two layers each 9,5 mm thick;
  - ii) for intended fire resistance of test specimen of between 30 min and 60 min — two layers each 12,5 mm thick;
  - iii) for intended fire resistance of test specimen of between 60 min and 90 min — three layers each 12,5 mm thick;
  - iv) for intended fire resistance of test specimen of between 90 min and 120 min — three layers each 12,5 mm thick (reinforced).

- 4) **Fixings** — self-drilling/self-tapping drywall screws:
  - 15 mm to 25 mm long for the first layer of 9,5 mm thick board;
  - 25 mm to 36 mm long for the second layer of 9,5 mm thick board;
  - 20 mm to 30 mm long for first layer of 15 mm thick board;
  - 31 mm to 41 mm long for second layer of 12,5 mm thick board;
  - 45 mm to 55 mm long for third layer of 12,5 mm thick board.
- 5) **Joining compound** — gypsum plaster.
- 6) **Insulation** — none.

**b) Construction**

- 1) **Fixing centres** — head/floor track to test frame  $\leq$  600 mm.
- 2) **Stud centres** — between 400 mm and 625 mm (depending on the size and position of the opening for the test specimen). These centres do not apply within the 200 mm separation between each specimen and between the specimens and the edge of the furnace.
- 3) **Stud fixing** — friction only. Expansion allowance for studs — 10 mm max. This is not a design allowance for expansion.
- 4) **Fixing centres** — gypsum board to framework, 300 mm around the periphery and in the field in all layers.
- 5) **Location of vertical joints** — to be staggered between layers of gypsum board, in multi-layer constructions.
- 6) **Location of horizontal joints** — to be coincident for one layer systems at a nominal height of 2 400 mm. If applicable, to be staggered between layers of gypsum board, in multi-layer constructions with the inner layer at a nominal height of 600 mm and the outer layer at a nominal height of 2 400 mm.

NOTE If the gypsum boards used in the flexible standard supporting construction are not full height (i.e. 3 m), then a horizontal joint will be needed at the locations stated above. The horizontal joint will need to be backed to prevent premature failure. A suitable method for this is to place a 100 mm wide fixing strap made from steel 0,5 mm thick behind the outer layer of board at the location of the joint. Drywall screws fixed through the outer layer of board at 300 mm centres are used to locate the fixing strap. For all systems, the fixing strap is only required behind the outer layer of board.

- 7) **Filling of joints** — outer layer only to be filled with gypsum plaster jointing compound

**6.4.3.2 Horizontal or inclined specimens**

Horizontal and inclined specimens will in most cases be installed in a type of supporting construction, proprietary in nature. Accordingly, the provisions of 6.4.2 apply.



## 7 Application of instrumentation

### 7.1 Furnace thermocouples (plate thermometer)

**7.1.1** Plate thermometers shall be provided for measuring the temperature of the furnace and shall be uniformly distributed to give a reliable indication of the temperature across the exposed face of the test specimen. These plate thermometers shall be constructed and located in accordance with ISO 834-1, with the sensing face parallel to the test specimen and facing away from the specimen.

**7.1.2** There shall be at least one plate thermometer for every 1,5 m<sup>2</sup> of the exposed surface area of the test construction. They shall be oriented so that Side "A" faces the back wall of the furnace.

### 7.2 Specimen thermocouples

**7.2.1** For unexposed surface temperature measurement, thermocouples constructed in accordance with ISO 834-1 shall be attached to the unexposed face at positions specified in that International Standard and in ISO 834-8.

**7.2.2** For insulated construction, thermocouples shall be placed on glazing and, if included, mullions and transoms. Thermocouples shall not be placed closer than 100 mm to any discrete area not being evaluated for insulation.

NOTE For the placing of thermocouples on specimens of both insulated and uninsulated glazing, illustrated by examples, see Annex B.

### 7.3 Furnace pressure

Provision shall be made for measuring and controlling the furnace pressure in accordance with ISO 834-1. For inclined glazed elements, see Clause 5.

### 7.4 Heat flux measurement

#### 7.4.1 General

This clause specifies a method of measuring heat flux. The hazard presented by radiation is evaluated in the test by measuring total heat flux. However, as the convected heat transfer is negligible, the measurement is reported as heat flux in this document. The measurement of heat flux is considered in a plane parallel to, and at a distance of 1,0 m from, the unexposed face of the test specimen, and includes — the concept of both an average value, measured opposite the centre of the specimen, and a maximum value which will be greater than or equal to the average value if the specimen is not a uniform radiator. Guidance is also provided on the determination of the maximum value.

There is no requirement for measuring the heat flux from a surface with a temperature below 300 °C. This is because the radiation emitted from such a surface is low — typically 6 kW/m<sup>2</sup> — even with an emissivity of 1,0.

#### 7.4.2 Apparatus

See Clause 4.

#### 7.4.3 Procedure

##### 7.4.3.1 Positioning

###### 7.4.3.1.1 General

Position each heat flux meter 1,0 m from the unexposed surface of the test specimen.

At the start of the test, the target of each heat flux meter shall be parallel ( $\pm 5^\circ$ ) to the plane of the unexposed surface of the test specimen and shall be pointing towards the unexposed surface of the test specimen.

There shall be no significant radiating surfaces other than the specimen within the field of view. The flux meter shall not be shielded or masked such that the field of view is restricted.

#### **7.4.3.1.2 Specific locations**

Measurements shall be taken at the following locations.

- a) Opposite the geometric centre of the specimen: referred to as the average heat flux level.
- b) At the point at which the maximum heat flux can be expected. Often this follows logically or can be calculated from the geometry of the specimen. If the specimen is symmetrical about its centre and a uniform radiator, this will coincide with position a).

If the specimen has areas of differing insulation and/or transmission, it may be difficult to predict the point of maximum intensity with any degree of certainty. In these cases the following procedure shall be used.

Identify all areas where it is anticipated that the temperature will exceed  $300^\circ\text{C}$  having an area in excess of  $0,1\text{ m}^2$ . Measure the heat flux opposite the notational centre of each area.

Two or more identical adjacent parts of the specimen having the same height or width, separated by less than  $0,1\text{ m}$ , may be treated jointly together as a single radiation surface.

If the area or sub-areas of the specimen expected to remain below  $300^\circ\text{C}$  are less than 10 % of the total area or sub-area under consideration, then that area or sub-area may be treated as a single radiating surface. This allows for breaks such as glazing bars. See Figure 4 for an example of measuring heat flux on an inclined glazed element.

#### **7.4.4 Measurement**

Measurements taken at each location according to 7.4.3.1.2 shall be recorded throughout the test at intervals not exceeding 1 min.

### **7.5 Deflection measurement**

While deflection of the specimen is not a classification criteria, wherever possible it shall be measured to provide a full movement history of the test specimen for extending the application of test results. See Figures B.1 and B.3 for example locations of deflection measurements.

## **8 Test procedure**

### **8.1 Furnace control**

Measure and control the furnace temperature and pressure conditions in accordance with ISO 834-1 or as modified by the requirements of this International Standard.

With the specimen in place, check the position of the furnace thermocouples for correct location with reference to the specimen face. Control the furnace so that these thermocouples follow the heating curve of ISO 834-1 within the prescribed tolerances. Maintain the pressure in the furnace within the limits given in Clause 5.

Dimensions in metres

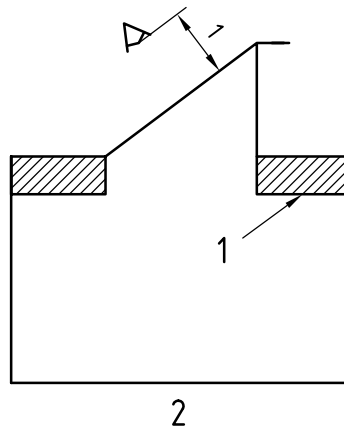
**Key**

heat flux meter

- 1 supporting construction  
2 furnace

**Figure 4 — Placement of heat flux meter — Inclined element**

## 8.2 Measurements and observations

Monitor the specimen for compliance with the criteria of integrity and insulation and carry out the required measurements and observations in accordance with ISO 834-1.

Make observations of the general behaviour of the specimen during the course of the test and record and note occurrences of deformation, cracking, softening, smoke emission, etc.

## 9 Performance criteria

The performance of the test specimen shall be judged on the basis of measurements and observations made during the test. No criteria are given in this International Standard for critical heat flux level.

The following are the appropriate performance criteria for both insulated and uninsulated glazed elements.

a) Insulated glazed elements:

- integrity — as defined in ISO 834-1;
- insulation — as defined in ISO 834-1.

b) Uninsulated glazed elements:

- integrity — as defined in ISO 834-1, excluding the cotton pad test;
- insulation — criteria are not necessary.

## 10 Validity of the test

The test shall be considered valid when it has been conducted within all prescribed limits of the requirements pertaining to

- test equipment,
- test conditions,
- test specimen preparation,
- instrument application, and
- test procedure in accordance with this International Standard.

The test shall also be considered for acceptance when the fire exposure conditions relating to furnace temperature, pressure and ambient temperature are in excess of the upper limits of the tolerances prescribed in this International Standard and in ISO 834-1.

## 11 Expression of results

The results of the fire resistance test shall be expressed as the completed elapsed time in minutes for which the integrity and insulation criteria have been satisfied. The results shall clearly indicate the direction of the fire exposure with respect to the face of the specimen and inclination of the test specimen. See Table 1 for the desired format.

**Table 1 — Expression of results**

Inclination	Orientation	Criteria	Result min
		Integrity — gap gauge	xx
		Cotton pad	xx
		Sustained flaming	xx
		Insulation	xx

## 12 Test report

The report shall be in accordance with ISO 834-1. The heat flux levels in relation to time shall be included. A time history of the heat flux measurement shall be expressed in graphical or tabular form.

At each specific measurement location, the time for the measured heat flux to exceed the value of 5 kW/m<sup>2</sup>, 10 kW/m<sup>2</sup>, 15 kW/m<sup>2</sup>, 20 kW/m<sup>2</sup> and 25 kW/m<sup>2</sup> shall be reported. A clear statement should be made as to whether this is on the basis of average or maximum values.

When describing the construction of glazed elements particular attention is required with respect to the following aspects of the construction.

### a) Glass

- 1) Glass type: trade name and brief description (e.g. insulated/non-insulated, coated/non-coated, solid/laminated).

- 2) Glass thickness,  $z$  (see Figure 2).
- 3) Aperture size: where  $y_1$  is width and  $y_2$  is height (see Figure 1).
- 4) Visible glass size: where  $x_1$  is width and  $x_2$  is height (see Figure 1).
- 5) Edge cover,  $w$  (see Figure 2).
- 6) Actual glass size ( $x + 2w$ ).
- 7) Expansion and framing allowance (aperture size minus actual).

**b) Glazing material**

- 1) Material type: trade name and brief description (e.g. gasket, sealant, channel, strip).
- 2) Dimensions (for gaskets and strips) (see Figure 2):
  - i) pre-installed,  $V_2$ ;
  - ii) post-installed,  $V_1$ .
- 3) Special materials (e.g. adhesives).
- 4) Setting blocks: materials, position and size.

**c) Beads and rebates**

- 1) Type: brief description and trade mark, if applicable.
- 2) Dimensions: depth,  $u$  (see Figure 2).
- 3) Fixings: type.
- 4) Dimensions, if applicable.
- 5) Frequency.

## Annex A (informative)

### Non-planar elements and test data application

#### A.1 Test principle

Glazing can be used as a discrete part of a building element such as a window or a light-transmitting panel in a wall, or it can form the whole of the separating element such as a glazed wall or a floor. If it is required to act as a fire barrier, it needs to be designed to prevent the transfer of fire from one side to the other. Two types of system are available:

- a multi-layer type, which is able to satisfy the insulation requirements of the standard test by the special layers between glass panes that turn opaque when heated and allow the wall to restrict the transfer of heat by radiation and conduction;
- a single-layer system, which can retain its integrity in the fire test and is not designed to restrict the transfer of heat.

These elements can, nevertheless, be designed to resist the passage of flames and hot gases. Such a barrier will allow transfer of heat, which can affect the safety of people and combustible goods in close proximity: the unexposed face temperatures could be high enough to cause ignition of combustible materials touching that surface. In certain building usage, this level of protection is considered adequate, as the safety of occupants has been assured by suitable means of escape and no combustible materials are at risk.

#### A.2 Guidance on testing non-planar elements

##### A.2.1 General

When testing non-planar glazing specimens, such as pyramids, some aspects of the test method given in this International Standard need to be modified. The following guidance is therefore given on how to adapt the main requirements concerned for performing a fire test on a glazed pyramid.

##### A.2.2 Test equipment

Perform the tests on a pyramid using the furnace used for horizontal glazed elements.

Depending on its end use, the pyramid may or may not be mounted in a restraint frame. However, in every case, mount the pyramid on a non-deformable support.

##### A.2.3 Test conditions

Two kinds of pyramids have to be considered: regular (see Figure A.1) and inverted (see Figure A.2).

For regular pyramids, fulfil the heating and pressure conditions of ISO 834-1 in a horizontal plane situated at 100 mm under the base of the pyramid (Figure A.3).

For inverted pyramids, fulfil

- the heating conditions of ISO 834-1, with plate thermometers uniformly distributed under the faces and located 100 mm from these faces (see Figure A.4), and

- the pressure conditions of ISO 834-1, with a pressure probe located at 100 mm from the lowest part of the pyramid (Figure A.5).

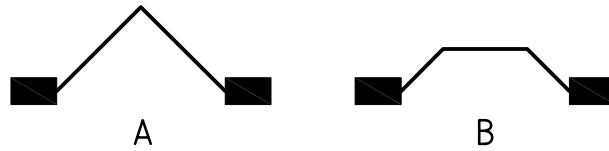

Figure A.1 — Examples of regular pyramids

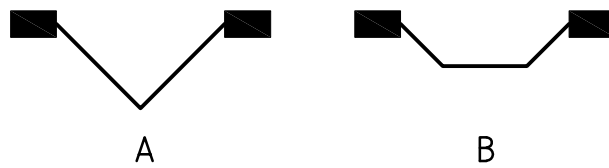
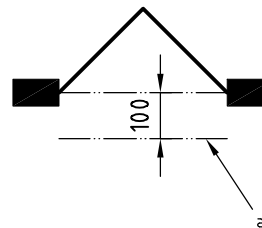

Figure A.2 — Examples of inverted pyramids

Dimensions in millimetres



- a Plane for recording temperature and pressure.

Figure A.3 — Regular pyramid — Example of measurement of gas temperature and pressure

Dimensions in millimetres

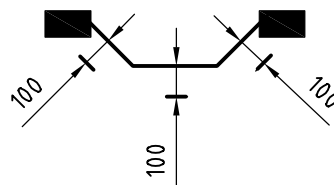

- plate thermocouple

Figure A.4 — Inverted pyramid — Example of measurement of gas temperature

Dimensions in millimetres

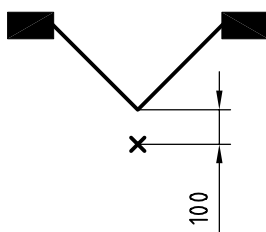

X pressure probe

Figure A.5 — Inverted pyramid — Example of measurement of pressure

### A.2.4 Application of instrumentation

With regular pyramids of identical inclined faces (as regards size, slope, percentage of glazing, etc.), heat flux measurement may be done for only one face. When one or more faces are not identical, measure heat flux for the face where the surface of glazing elements is maximum.

With inverted pyramids, measure the heat flux by taking as the radiative surface the opening in the supporting structure (see Figure A.6).

Dimensions in metres

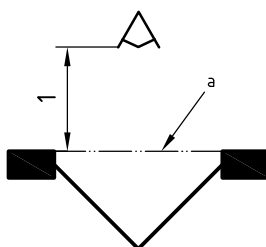

#### Key

△ flux meter

<sup>a</sup> Opening in supporting structure.

Figure A.6 — Inverted pyramid — Example for measurement of heat flux

### A.2.5 Field of direct application

Regarding the whole specimen:

- the linear size of the basement of the pyramid may be changed within + 10 % to – 30 % of the size of the tested specimen;
- the slope of each face remains unchanged;
- the direction of the summit of the pyramid is unchanged (it is not possible to apply the test result from a regular pyramid to an inverted pyramid or vice versa).



### A.3 Applicability of results

The results of the test described in this annex are only directly applicable to elements of the same construction but of different sizes where a decrease in any linear dimension of the individual panes of glazing is made. The effect of increasing pane sizes, the aspect ratio or the orientation (other than according to Table A.1) cannot be directly predicted.

When, in practice, the element is to be installed in a bounding construction that cannot provide as much restraint as the specimen support frame or which requires different methods of fixing or — especially in respect of insulating constructions — has different thermal characteristics, then the influence of these changes will need to be the subject of an extended application analysis before the results of the test may be applied to that application. See ISO/TR 12470 for further details.

Table A.1 gives the test specimen angles with results applicable to the glazed element angles in use.

**Table A.1 — Applicability of test results**

Test specimen angle $\alpha^\circ$	Applicable to glazed element angles in use
$80^\circ < \alpha_{\text{test}} \leq 90^\circ$	$80^\circ < \alpha_{\text{use}} \leq 90^\circ$
$\alpha_{\text{test}} = 45^\circ$ or $15^\circ \leq \alpha_{\text{test}} \leq 80^\circ$	$15^\circ \leq \alpha_{\text{use}} \leq 80^\circ$  $\alpha_{\text{use}} = \alpha_{\text{test}} \pm 15^\circ$
$0^\circ \leq \alpha_{\text{test}} < 15^\circ$	$0^\circ < \alpha_{\text{use}} \leq 15^\circ$
If tests are conducted at $0^\circ$ , $45^\circ$ and $90^\circ$ on the same glazing system, the minimum rating for the three tests applies to all angles (namely: $0^\circ$ to $90^\circ$ ).	

## Annex B (normative)

### Test specimens — Testing insulated and uninsulated glazing

#### B.1 General

A glazed element can consist of a discrete glazed panel or a substantial number of such panels can be made up almost entirely of glazed units. These could be small-framed units or large panes with substantial frames attached to masonry or similar surrounds. Under fire conditions, the separating element is expected to remain a satisfactory fire barrier: this requirement applies to glazed and unglazed parts of the system.

The fire resistance of a glazed system is a function of the nature of the glass, the size and aspect ratio of the panes, the characteristics of the framing members, the method of retention and the expansion provisions.

If the objective of a fire test is to obtain information on a specific system for a particular end use, then the specific construction is used for the test specimen. However, if the intention is to obtain data for a wider application to other similar constructions, then a single test may justify this, depending on the inclusion of certain design features in the test specimen.

See A.3 for the applicability of results to other, similar constructions.

#### B.2 Test specimen design

The test specimen shall be either

- a) fully representative of the construction intended for use in practice, including any surface finishes and fittings which are essential and which could influence its behaviour in test, or
- b) designed to obtain the widest applicability of the test result to other similar constructions (the design features influencing fire performance that should be included to give the widest application may be derived from the field of direct application) (see A.3).

The test specimen shall not contain mixtures of different types of construction, for example, different types of glass, unless this is fully representative of the construction in practice.

The following features may only be incorporated in similar constructions provided they were included in the test specimen:

- non-glazed panels;
- junction or junctions between a transom and a mullion (“+”);
- junction or junctions of mullions terminating at a transom (“T”);
- junction or junctions between transoms and mullions where mullions are full height and interrupt transoms;
- special jointing systems between glazed elements or between glazed elements and other constructions;
- other constructional features to be evaluated, for example, structures present for safety or security (crowd barriers, grilles, etc.).

## B.3 Test specimen instrumentation

### B.3.1 General

If the test specimen consists entirely of uninsulated glazing, it shall be treated as an uninsulated glazed element and no unexposed surface thermocouples need be attached. It shall only be evaluated with respect to the integrity criteria, and, where required, radiation.

If the test specimen has one or more discrete panes of uninsulated glazing, it shall be treated as a partly insulated glazed element. The insulated part may be required to provide the necessary thermal insulation, for which purpose the appropriate number of thermocouples shall be provided. No thermocouples are required to be placed on the uninsulated glazing.

If the entire test specimen is made using insulating glazing (and frames), it shall be treated as fully insulated and its performance judged on the basis of compliance with the criteria of integrity and insulation.

Thermocouples of the type specified in ISO 834-1 shall be attached to the unexposed face for the purpose of obtaining the average and the maximum surface temperatures. The general rules for the attachment and exclusion of thermocouples given in ISO 834-1 shall apply, with the following variations.

See Figures B.1 to B.4.

### B.3.2 Average temperature rise

#### B.3.2.1 Uniform glazing

For the purposes of measuring the average temperature rise, one thermocouple shall be provided for every 1,5 m<sup>2</sup> or part thereof of the specimen. A minimum of two thermocouples for each pane of glass shall be provided. The two thermocouples shall be positioned at the centre of two quarters of each pane diagonally opposite each other. Any additional thermocouples shall be evenly distributed over the surface of the pane. Some typical examples are shown in Figure B.3.

#### B.3.2.2 Non-uniform glazing

For test specimens of non-uniform glazing, i.e. those containing different discrete areas, each discrete area shall be individually monitored for average temperature rise as in B.3.2.1. Some typical examples are shown in Figure B.1.

### B.3.3 Maximum temperature rise

Additional thermocouples shall be attached to the framing members in order to judge compliance with the maximum temperature rise criterion as follows:

- a) at mid-width of each edge (100 mm in from the free edge);
- b) at each edge of the specimen in line with a mullion;
- c) at the junction of a mullion and a transom;
- d) at mid-position, where possible, adjacent to a joint;
- e) in the centre of any framing of any glazing system.

Thermocouples shall not be positioned closer than 100 mm from any discrete area not being evaluated for insulation.

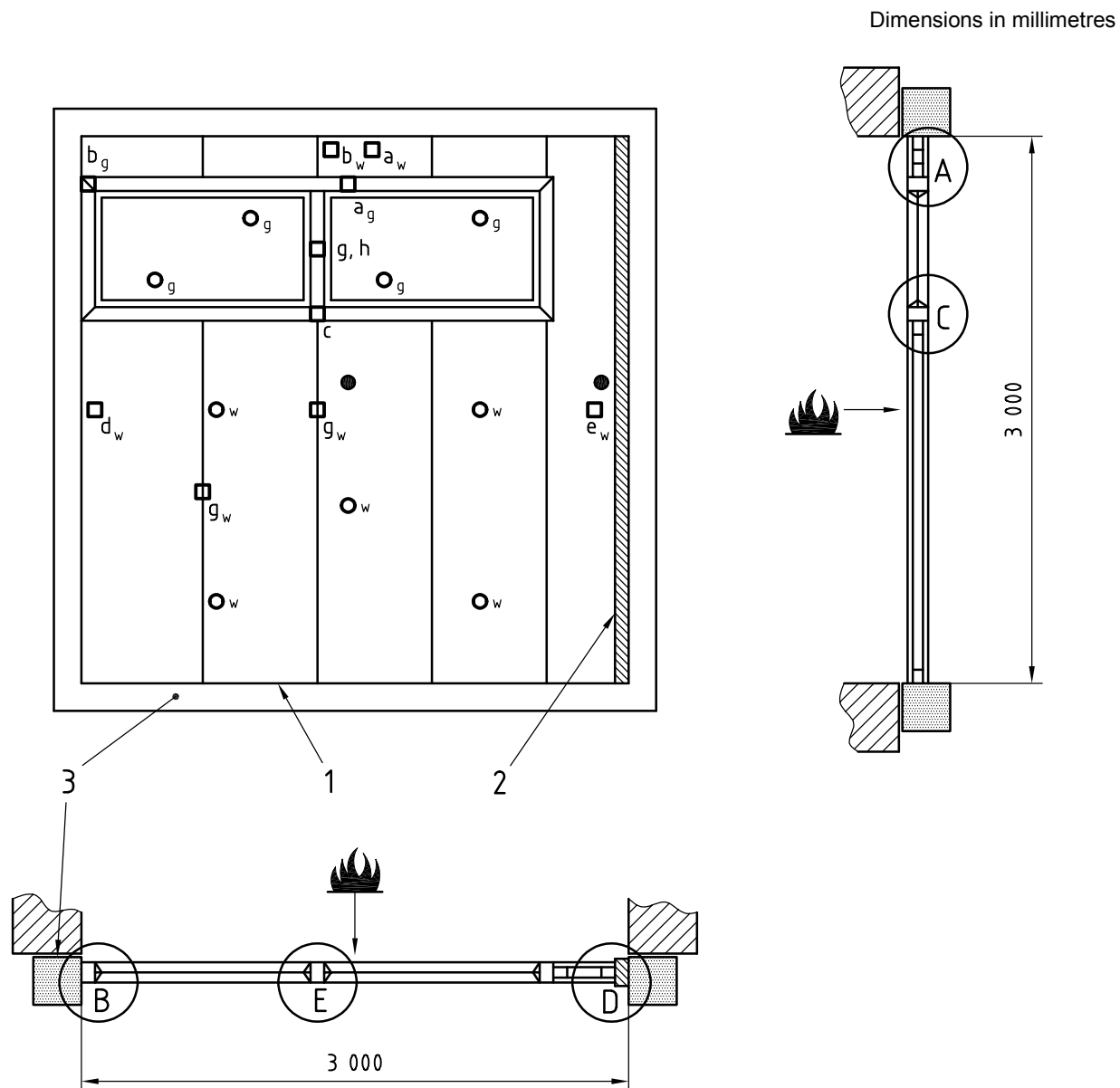

**Key**

- <sub>w</sub> position of thermocouples for average temperature rise (see ISO 834-8)
- <sub>g</sub> position of thermocouples for average temperature rise (see B.3.2)
- ◻<sub>w</sub> position of thermocouples for maximum temperature rise of solid wall (see ISO 834-8)
- ◻<sub>g</sub> position of thermocouples for maximum temperature rise (see B.3.3)
- positions for deflection measurements

- 1 fixed edge
- 2 free edge
- 3 test frame

NOTE For Details A, B, C, D and E, see Figure B.2.

**Figure B.1 — Example of unexposed face thermocouples and deflection measurement positions for solid walls with area of insulated glazing (two discrete areas)**

Dimensions in millimetres

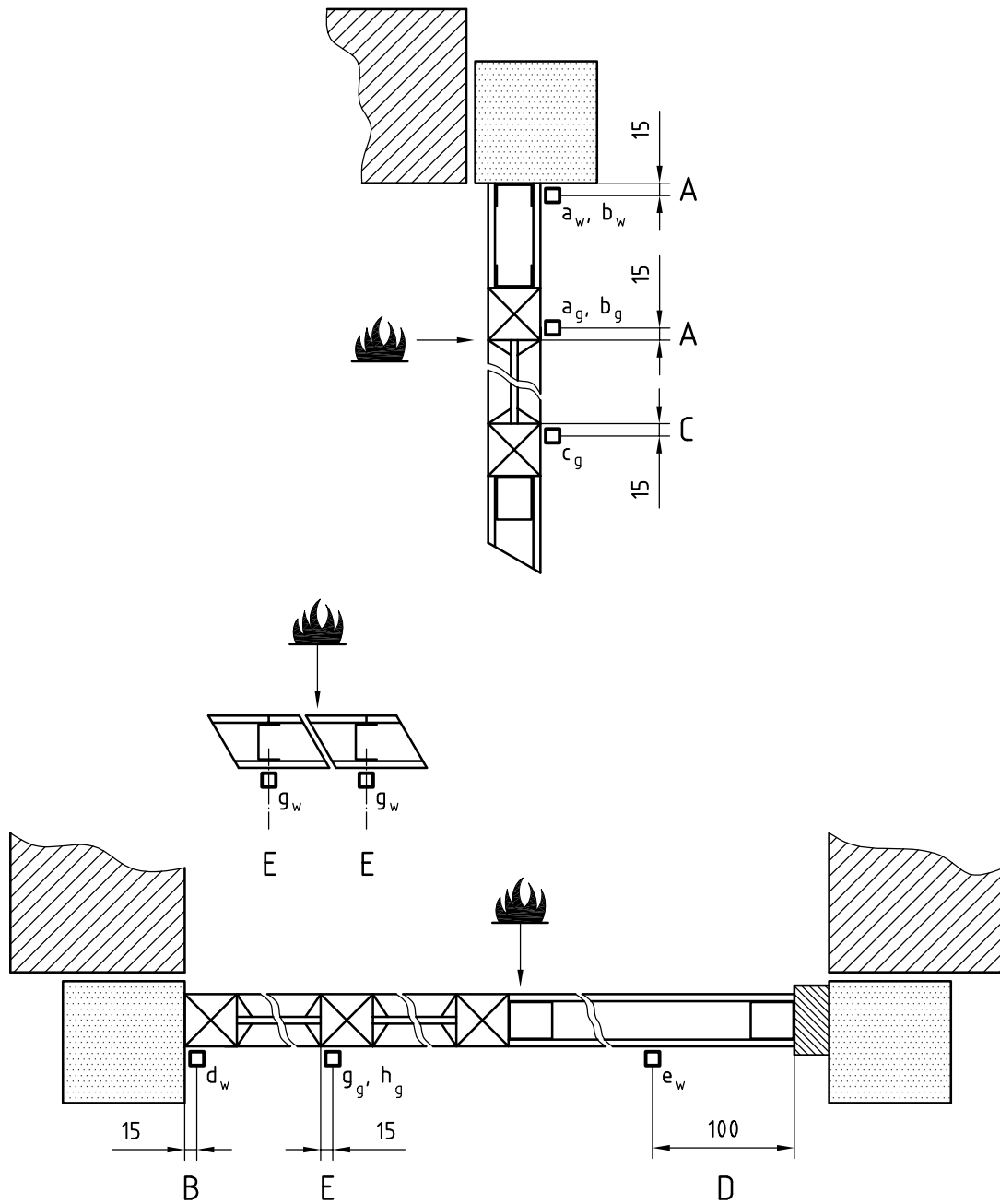

**Key**

- $\square_w$  position of thermocouples for maximum temperature rise of solid wall (see ISO 834-8)
- $\square_g$  position of thermocouples for maximum temperature rise glass

NOTE For overall location of thermocouples, see Figure B.1.

**Figure B.2 — Example of unexposed face thermocouple positions for solid walls with areas of glazing, insulating glass**

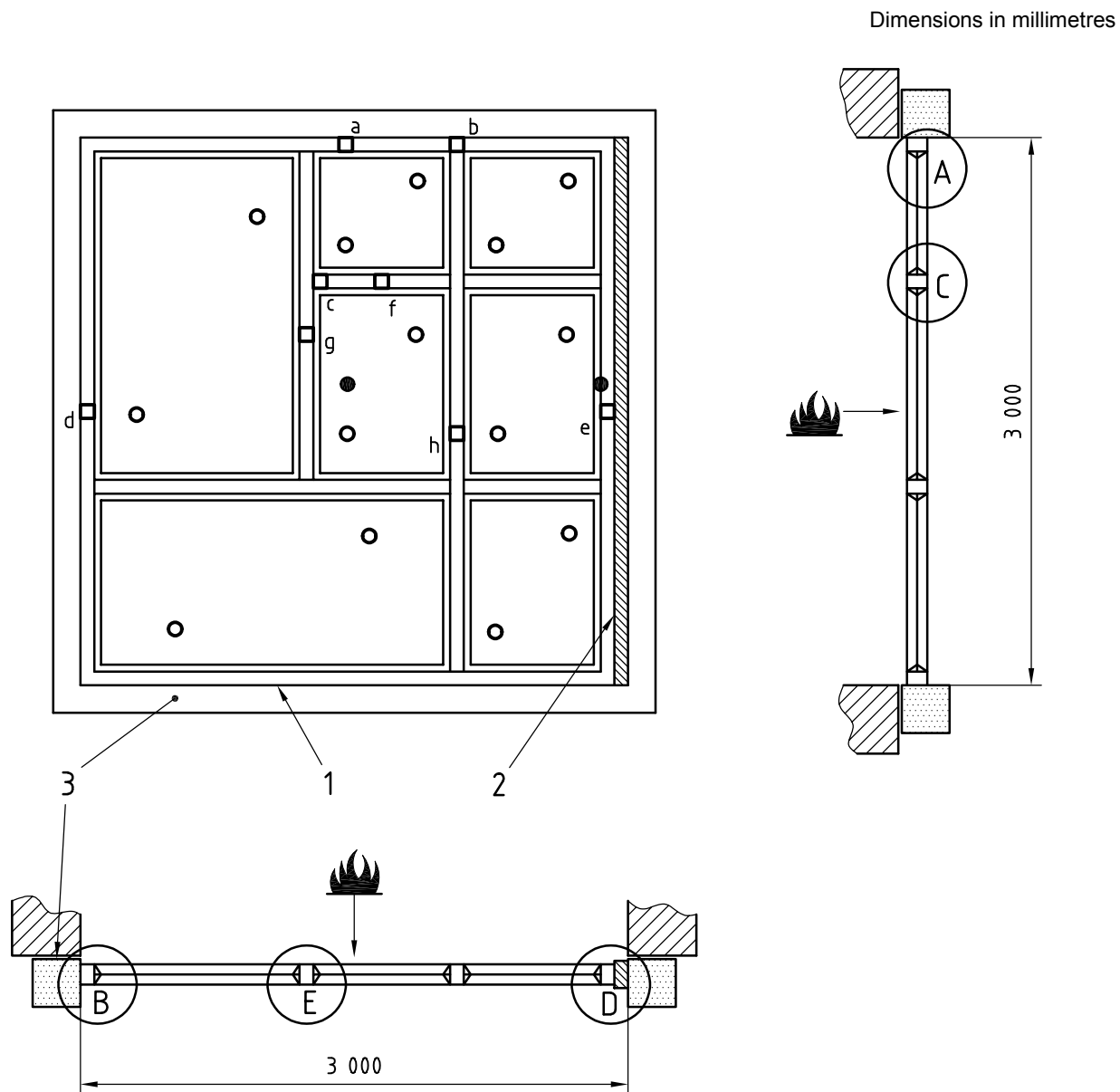

**Key**

- position of thermocouples for average temperature rise (see B.3.2)
- position of thermocouples for maximum temperature rise (see B.3.3)
- position for deflection measurement

- 1 fixed edge
- 2 free edge
- 3 test frame

NOTE For Details A, B, C, D and E, see Figure B.4.

**Figure B.3 — Example of location of unexposed thermocouples and deflection measurement positions for fully glazed walls**

Dimensions in millimetres

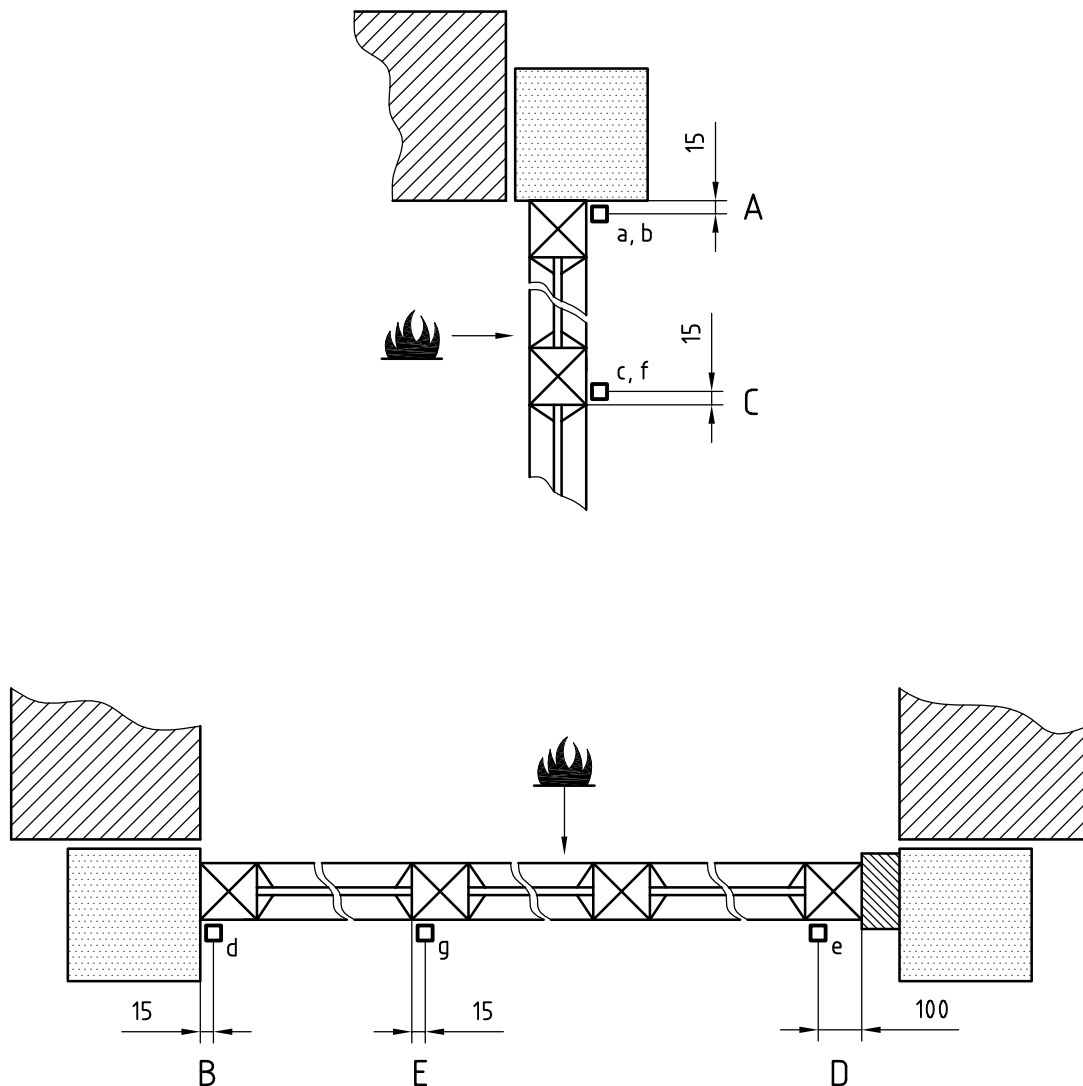
**Key**

- position of thermocouple for maximum temperature rise (see B.3.3)

NOTE For overall location of thermocouples, see Figure B.1.

**Figure B.4 — Example of unexposed thermocouple positions for fully glazed walls**

**B.3.4 Radiation measurement**

In some cases there could be a requirement to establish the radiation from the unexposed face of the glazing. In such cases, provision shall be made to measure the radiation from the unexposed face in accordance with 7.4.

**B.4 Performance criteria****B.4.1 Integrity**

The criteria by which the integrity performance of the test specimen is judged shall be in accordance with ISO 834-1.

## **B.4.2 Insulation**

### **B.4.2.1 General**

The criteria by which the insulation performance of the test specimen is judged in accordance with ISO 834-1.

For glazing which incorporates discrete areas of different thermal insulation, compliance with the insulation criteria shall be determined separately for each area.

### **B.4.2.2 Average temperature rise**

Compliance shall be derived from the thermocouples specified in B.3.2.

### **B.4.2.3 Maximum temperature rise**

Compliance shall be derived from the thermocouples specified in B.3.3.

## **B.5 Field of direct application of test results**

### **B.5.1 General**

The results of the fire test may be directly applied to similar constructions where one or more of the changes listed below are made and the construction continues to comply with the appropriate design code for its stiffness and stability. Other changes are not permitted.

- a) Decrease in the linear dimensions of panes.
- b) Change in the aspect ratio of panes, provided that the largest dimension of the pane and its area are not increased.
- c) Decrease in the distance between mullions or transoms or both.
- d) Decrease in distance between fixing centres.
- e) Increase in the dimensions of framing members.
- f) Screwed-on glazing beads, if "clip-on" beads were incorporated in the test specimen.
- g) Allowances for expansion, if none were incorporated in the test specimen.

### **B.5.2 Extension of height**

No extension in height or in span is allowed above that tested.

### **B.5.3 Extension of width of vertical element**

The width of an identical construction may be increased if the specimen was tested at a minimum nominal width of 3 m with one vertical edge without restraint.



## **B.5.4 Supporting constructions**

### **B.5.4.1 Standard supporting constructions**

The result of a test of fire-resistant glazing in one of the standard supporting constructions specified in 6.4.3.1.2 to 6.4.3.1.5 may be applied to any other supporting construction, or test frame, of the same type (high-density rigid, low-density rigid or flexible) having greater fire resistance.

### **B.5.4.2 Non-standard supporting constructions**

The result of a test of fire-resistant glazing in a non-standard supporting construction shall only be applied to that construction.

## Bibliography

- [1] ISO/TR 834-3, *Fire-resistance tests — Elements of building construction — Part 3: Commentary on test method and test data application*
- [2] ISO 834-8, *Fire-resistance tests — Elements of building construction — Part 8: Specific requirements for non-loadbearing vertical separating elements*
- [3] ISO 834-9, *Fire-resistance tests — Elements of building construction — Part 9: Specific requirements for non-loadbearing ceiling elements*
- [4] ISO 3008, *Fire-resistance tests — Door and shutter assemblies*
- [5] ISO/TR 12470, *Fire-resistance tests — Guidance on the application and extension of results*



---

---

## BSI — British Standards Institution

BSI is the independent national body responsible for preparing British Standards. It presents the UK view on standards in Europe and at the international level. It is incorporated by Royal Charter.

### Revisions

British Standards are updated by amendment or revision. Users of British Standards should make sure that they possess the latest amendments or editions.

It is the constant aim of BSI to improve the quality of our products and services. We would be grateful if anyone finding an inaccuracy or ambiguity while using this British Standard would inform the Secretary of the technical committee responsible, the identity of which can be found on the inside front cover.  
Tel: +44 (0)20 8996 9000. Fax: +44 (0)20 8996 7400.

BSI offers members an individual updating service called PLUS which ensures that subscribers automatically receive the latest editions of standards.

### Buying standards

Orders for all BSI, international and foreign standards publications should be addressed to Customer Services. Tel: +44 (0)20 8996 9001.  
Fax: +44 (0)20 8996 7001. Email: [orders@bsi-global.com](mailto:orders@bsi-global.com). Standards are also available from the BSI website at <http://www.bsi-global.com>.

In response to orders for international standards, it is BSI policy to supply the BSI implementation of those that have been published as British Standards, unless otherwise requested.

### Information on standards

BSI provides a wide range of information on national, European and international standards through its Library and its Technical Help to Exporters Service. Various BSI electronic information services are also available which give details on all its products and services. Contact the Information Centre.  
Tel: +44 (0)20 8996 7111. Fax: +44 (0)20 8996 7048. Email: [info@bsi-global.com](mailto:info@bsi-global.com).

Subscribing members of BSI are kept up to date with standards developments and receive substantial discounts on the purchase price of standards. For details of these and other benefits contact Membership Administration.  
Tel: +44 (0)20 8996 7002. Fax: +44 (0)20 8996 7001.  
Email: [membership@bsi-global.com](mailto:membership@bsi-global.com).

Information regarding online access to British Standards via British Standards Online can be found at <http://www.bsi-global.com/bsonline>.

Further information about BSI is available on the BSI website at <http://www.bsi-global.com>.

### Copyright

Copyright subsists in all BSI publications. BSI also holds the copyright, in the UK, of the publications of the international standardization bodies. Except as permitted under the Copyright, Designs and Patents Act 1988 no extract may be reproduced, stored in a retrieval system or transmitted in any form or by any means – electronic, photocopying, recording or otherwise – without prior written permission from BSI.

This does not preclude the free use, in the course of implementing the standard, of necessary details such as symbols, and size, type or grade designations. If these details are to be used for any other purpose than implementation then the prior written permission of BSI must be obtained.

Details and advice can be obtained from the Copyright & Licensing Manager.  
Tel: +44 (0)20 8996 7070. Fax: +44 (0)20 8996 7553.  
Email: [copyright@bsi-global.com](mailto:copyright@bsi-global.com).