

BS ISO 2725-1:2015



BSI Standards Publication

# Assembly tools for screws and nuts — Square drive sockets

Part 1: Hand-operated sockets

**bsi.**

...making excellence a habit.™

**National foreword**

This British Standard is the UK implementation of ISO 2725-1:2015.

The UK participation in its preparation was entrusted to Technical Committee MTE/15, Hand tools.

A list of organizations represented on this committee can be obtained on request to its secretary.

This publication does not purport to include all the necessary provisions of a contract. Users are responsible for its correct application.

© The British Standards Institution 2015.  
Published by BSI Standards Limited 2015

ISBN 978 0 580 84441 6

ICS 25.140.30

**Compliance with a British Standard cannot confer immunity from legal obligations.**

This British Standard was published under the authority of the Standards Policy and Strategy Committee on 31 March 2015.

**Amendments/corrigenda issued since publication**

Date	Text affected
------	---------------

---

---

---

**Assembly tools for screws and nuts —  
Square drive sockets —**

Part 1:  
**Hand-operated sockets**

*Outils de manoeuvre pour vis et écrous — Douilles à carré  
conducteur femelle —*

*Partie 1: Douilles à main*





**COPYRIGHT PROTECTED DOCUMENT**

© ISO 2015

All rights reserved. Unless otherwise specified, no part of this publication may be reproduced or utilized otherwise in any form or by any means, electronic or mechanical, including photocopying, or posting on the internet or an intranet, without prior written permission. Permission can be requested from either ISO at the address below or ISO's member body in the country of the requester.

ISO copyright office  
Case postale 56 • CH-1211 Geneva 20  
Tel. + 41 22 749 01 11  
Fax + 41 22 749 09 47  
E-mail [copyright@iso.org](mailto:copyright@iso.org)  
Web [www.iso.org](http://www.iso.org)

Published in Switzerland

# Contents

	Page
Foreword .....	iv
<b>1 Scope .....</b>	<b>1</b>
<b>2 Normative references .....</b>	<b>1</b>
<b>3 Tolerances for width across flats .....</b>	<b>1</b>
<b>4 Dimensions .....</b>	<b>1</b>
<b>5 Technical specifications .....</b>	<b>7</b>
<b>6 Designation .....</b>	<b>7</b>
<b>7 Marking .....</b>	<b>7</b>
<b>Bibliography .....</b>	<b>8</b>

## Foreword

ISO (the International Organization for Standardization) is a worldwide federation of national standards bodies (ISO member bodies). The work of preparing International Standards is normally carried out through ISO technical committees. Each member body interested in a subject for which a technical committee has been established has the right to be represented on that committee. International organizations, governmental and non-governmental, in liaison with ISO, also take part in the work. ISO collaborates closely with the International Electrotechnical Commission (IEC) on all matters of electrotechnical standardization.

The procedures used to develop this document and those intended for its further maintenance are described in the ISO/IEC Directives, Part 1. In particular the different approval criteria needed for the different types of ISO documents should be noted. This document was drafted in accordance with the editorial rules of the ISO/IEC Directives, Part 2 (see [www.iso.org/directives](http://www.iso.org/directives)).

Attention is drawn to the possibility that some of the elements of this document may be the subject of patent rights. ISO shall not be held responsible for identifying any or all such patent rights. Details of any patent rights identified during the development of the document will be in the Introduction and/or on the ISO list of patent declarations received (see [www.iso.org/patents](http://www.iso.org/patents)).

Any trade name used in this document is information given for the convenience of users and does not constitute an endorsement.

For an explanation on the meaning of ISO specific terms and expressions related to conformity assessment, as well as information about ISO's adherence to the WTO principles in the Technical Barriers to Trade (TBT), see the following URL: [Foreword — Supplementary information](#).

The committee responsible for this document is ISO/TC 29, *Small tools*, Subcommittee SC 10, *Assembly tools for screws and nuts, pliers and nippers*.

This third edition cancels and replaces the second edition (ISO 2725-1:2007), which has been technically revised.

The following main changes have been made with respect to the previous edition:

- a) additional widths across flat sizes not covered by ISO 272 included, in order to better reflect the current market situation;
- b)  $d_{3\min}$  calculated from maximum thread diameter  $D_{\max}$  (the largest nominal thread diameter found in current standards);
- c) the values of  $t_{\min}$  have been changed to the maximum thread diameter ( $t_{\min} = m_{\max} + 0,1$ ).

ISO 2725 consists of the following parts, under the general title *Assembly tools for screws and nuts — Square drive sockets*:

- *Part 1: Hand-operated sockets*
- *Part 2: Machine-operated sockets ('impact')*
- *Part 3: Machine-operated sockets ('non-impact')*

# Assembly tools for screws and nuts — Square drive sockets —

## Part 1: Hand-operated sockets

### 1 Scope

This part of ISO 2725 specifies dimensions, the designation, and the marking of hand-operated square drive sockets with operating end and having a hexagonal or double hexagonal form in accordance with ISO 1174-1.

NOTE 1 Hand-operated square drive sockets are listed under number 2 1 02 01 0 in ISO 1703.

NOTE 2 The figures in this part of ISO 2725 are given only as examples. They are not intended to influence the manufacturer's design.

### 2 Normative references

The following documents, in whole or in part, are normatively referenced in this document and are indispensable for its application. For dated references, only the edition cited applies. For undated references, the latest edition of the referenced document (including any amendments) applies.

ISO 691, *Assembly tools for screws and nuts — Wrench and socket openings — Tolerances for general use*

ISO 1174-1, *Assembly tools for screws and nuts — Driving squares — Part 1: Driving squares for hand socket tools*

ISO 1711-1, *Assembly tools for screws and nuts — Technical specifications — Part 1: Hand-operated wrenches and sockets*

ISO 4014, *Hexagon head bolts — Product grades A and B*

ISO 4032, *Hexagon regular nuts (style 1) — Product grades A and B*

### 3 Tolerances for width across flats

Tolerances for width across flats,  $s$ , shall be in conformity with the tolerances for socket openings given in ISO 691. Manufacturers are free to choose the series of deviations.

### 4 Dimensions

[Table 1](#) to [Table 5](#) give the dimensions, in millimetre, of sockets shown in [Figure 1](#) to [Figure 3](#) for driving squares of 6,3 to 25 (in accordance with ISO 1174-1).

NOTE Width across flats,  $s$ , are partly taken from ISO 272.

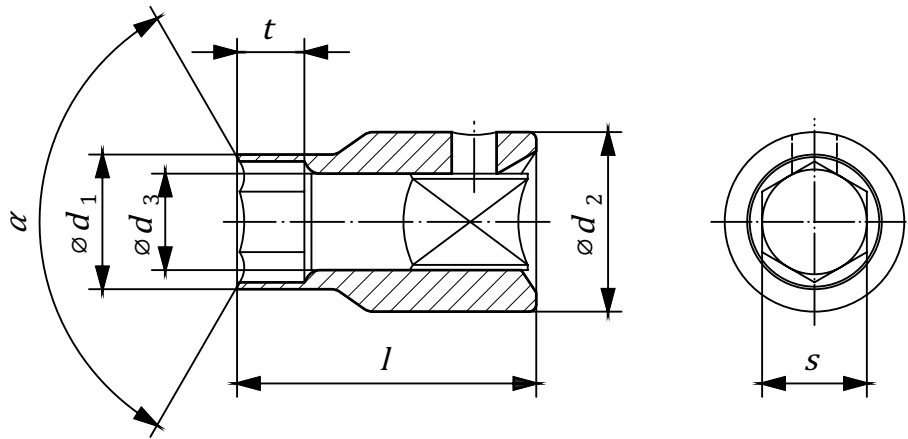

$\alpha \quad 115^\circ \leq \alpha \leq 150^\circ$

**Figure 1 — Sockets with  $d_1 < d_2$**

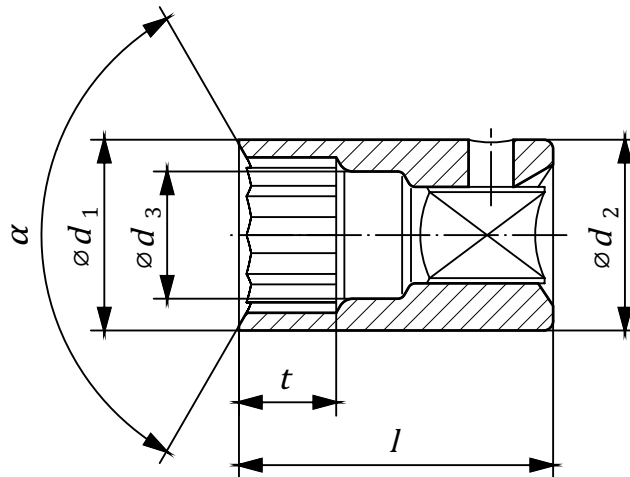

$\alpha \quad 115^\circ \leq \alpha \leq 150^\circ$

**Figure 2 — Sockets with  $d_1 = d_2$**



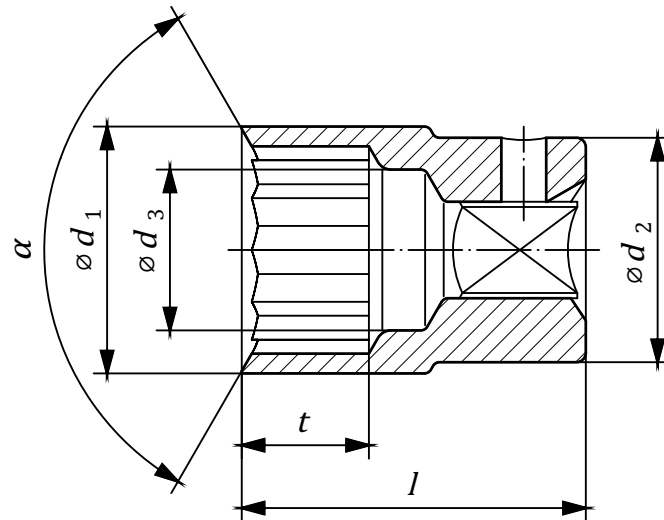

$\alpha \quad 115^\circ \leq \alpha \leq 150^\circ$

Figure 3 — Sockets with  $d_1 > d_2$

Table 1 — Square drive of 6,3

s	Dmax <sup>c</sup> mm	t <sup>a</sup> min. mm	d <sub>1</sub> max. mm	d <sub>2</sub> max. mm	d <sub>3</sub> <sup>b</sup> min. mm	l	
						max. Type A (normal) mm	min. Type B (long) mm
3,2	1,6	1,4	5,9	12,5	1,7	26	45
4	2	1,7	6,9	12,5	2,1	26	45
5	2,5	2,1	8,2	12,5	2,6	26	45
5,5	3	2,5	8,8	12,5	3,2	26	45
6 <sup>d</sup>	3,5 <sup>f</sup>	2,9	9,4	12,5	3,7	26	45
7	5	3,3	11	12,5	5,3	26	45
8	6	4,8	12,2	12,5	6,3	26	45
9 <sup>d</sup>	6 <sup>e</sup>	5,1	13,5	13,5	6,3	26	45
10	8	5,3	14,7	14,7	8,4	26	45
11	8 <sup>e</sup>	5,8	16	16	8,4	26	45
12 <sup>d</sup>	8	6,4	17,2	17,2	8,4	26	45

NOTE  $t_{\min}$  is interpolated for sizes not covered by ISO 4032 and ISO 4014.

<sup>a</sup>  $t_{\min} = m_{\max} + 0,1$ ; where  $m_{\max}$  is the maximum height of the nut, according to ISO 4032.

<sup>b</sup>  $d_{3\min} = D_{\max} \times 1,05$

<sup>c</sup> The maximum thread diameter  $D_{\max}$  is the largest nominal thread diameter found in current International Standards like, e.g. ISO 4014, ISO 4032, ISO 272.

<sup>d</sup> Nominal dimension not covered by ISO 272.

<sup>e</sup> Value determined in order to avoid reduction in hole clearance size.

<sup>f</sup> Value taken from DIN 934

**Table 1 (continued)**

s	Dmax <sup>c</sup> mm	t <sup>a</sup> min. mm	d <sub>1</sub> max. mm	d <sub>2</sub> max. mm	d <sub>3</sub> <sup>b</sup> min. mm	l	
						Bolt clearance hole mm	max. Type A (normal) mm
					13	10	6,9
14 <sup>d</sup>	10	7,4	19,7	19,7	10,5	26	46
15 <sup>d</sup>	12	8,0	21,5	21,5	12,6	26	45
16	12 <sup>e</sup>	8,5	22	22	12,6	26	45

NOTE t<sub>min</sub> is interpolated for sizes not covered by ISO 4032 and ISO 4014.

a t<sub>min</sub> = m<sub>max</sub> + 0,1; where m<sub>max</sub> is the maximum height of the nut, according to ISO 4032.

b d<sub>3min</sub> = Dmax × 1,05

c The maximum thread diameter Dmax is the largest nominal thread diameter found in current International Standards like, e.g. ISO 4014, ISO 4032, ISO 272.

d Nominal dimension not covered by ISO 272.

e Value determined in order to avoid reduction in hole clearance size.

f Value taken from DIN 934

**Table 2 — Square drive of 10**

s	Dmax <sup>c</sup> mm	t <sup>a</sup> min. mm	d <sub>1</sub> max. mm	d <sub>2</sub> max. mm	d <sub>3</sub> <sup>b</sup> min. mm	l	
						Bolt clearance hole mm	max. Type A (normal) mm
					7	5	3,3
8	6	4,8	12,2	20	6,3	32	44
9 <sup>d</sup>	6 <sup>e</sup>	5,1	13,5	20	6,3	32	44
10	8	5,3	14,7	20	8,4	32	44
11	8 <sup>e</sup>	5,8	16	20	8,4	32	44
12 <sup>d</sup>	8	6,4	17,2	20	8,4	32	44
13	10	6,9	18,5	20	10,5	32	44
14 <sup>d</sup>	10	7,4	19,7	24	10,5	32	45
15 <sup>d</sup>	12	8,0	21,0	24	12,6	32	45
16	12 <sup>e</sup>	8,5	22,2	24	12,6	35	50
17 <sup>d</sup>	12	9,7	23,5	24	12,6	35	54
18	14	10,9	24,7	24,7	14,7	35	54
19 <sup>d</sup>	14	11,9	26	26	14,7	35	60

NOTE t<sub>min</sub> is interpolated for sizes not covered by ISO 4032 and ISO 4014.

a t<sub>min</sub> = m<sub>max</sub> + 0,1; where m<sub>max</sub> is the maximum height of the nut, according to ISO 4032.

b d<sub>3min</sub> = Dmax × 1,05

c The maximum thread diameter Dmax is the largest nominal thread diameter found in a current International Standards like, e.g. ISO 4014, ISO 4032, ISO 272.

d Nominal dimension not covered by ISO 272.

e Value determined in order to avoid reduction in hole clearance size.

Table 2 (continued)

s	Dmax <sup>c</sup> mm	t <sup>a</sup> min. mm	d <sub>1</sub> max. mm	d <sub>2</sub> max. mm	d <sub>3</sub> <sup>b</sup> min. mm	l	
						Bolt clearance hole mm	max. Type A (normal) mm
					21	16	12,9
22 <sup>d</sup>	16	13,9	29,7	29,7	16,8	38	60
24	16	14,9	32,5	32,5	16,8	38	65

NOTE  $t_{\min}$  is interpolated for sizes not covered by ISO 4032 and ISO 4014.

a  $t_{\min} = m_{\max} + 0,1$ ; where  $m_{\max}$  is the maximum height of the nut, according to ISO 4032.

b  $d_{3\min} = D_{\max} \times 1,05$

c The maximum thread diameter  $D_{\max}$  is the largest nominal thread diameter found in a current International Standards like, e.g. ISO 4014, ISO 4032, ISO 272.

d Nominal dimension not covered by ISO 272.

e Value determined in order to avoid reduction in hole clearance size.

Table 3 — Square drive of 12,5

s	Dmax <sup>c</sup> mm	t <sup>a</sup> min. mm	d <sub>1</sub> max. mm	d <sub>2</sub> max. mm	d <sub>3</sub> <sup>b</sup> min. mm	l	
						Bolt clearance hole mm	max. Type A (normal) mm
					8	6	4,8
9 <sup>d</sup>	6 <sup>e</sup>	5,1	14,1	24	5,8	40	75
10	8	5,3	15,5	24	8,4	40	75
11	8 <sup>e</sup>	5,8	16,7	24	8,4	40	75
12 <sup>d</sup>	8	6,4	18	24	8,4	40	75
13	10	6,9	19,2	24	10,5	40	75
14 <sup>d</sup>	10	7,4	20,5	24	10,5	40	75
15 <sup>d</sup>	12	8,0	21,7	24	12,6	40	75
16	12 <sup>e</sup>	8,5	23	25,5	12,6	40	75
17 <sup>d</sup>	12	9,7	24,2	25,5	12,6	40	75
18	14	10,9	25,5	25,5	14,7	42	75
19 <sup>d</sup>	14	11,9	26,7	26,7	14,7	42	75
21	16	12,9	29,2	29,2	16,8	44	75
22 <sup>d</sup>	16	13,9	30,5	30,5	16,8	44	75
24	16	14,9	33	33	16,8	46	75

NOTE  $t_{\min}$  is interpolated for sizes not covered by ISO 4032 and ISO 4014.

a  $t_{\min} = m_{\max} + 0,1$ ; where  $m_{\max}$  is the maximum height of the nut, according to ISO 4032.

b  $d_{3\min} = D_{\max} \times 1,05$

c The maximum thread diameter  $D_{\max}$  is the largest nominal thread diameter found in current International Standards like, e.g. ISO 4014, ISO 4032, ISO 272.

d Nominal dimension not covered by ISO 272.

e Value determined in order to avoid reduction in hole clearance size.

**Table 3 (continued)**

s	Dmax <sup>c</sup> mm	t <sup>a</sup> min. mm	d <sub>1</sub> max. mm	d <sub>2</sub> max. mm	d <sub>3b</sub> <sup>b</sup> min.	l	
					Bolt clearance hole mm	max. Type A (normal) mm	min. Type B (long) mm
27	20	15,9	36,7	36,7	21,0	48	75
30	20	18,1	40,5	40,5	21,0	50	75
32 <sup>d</sup>	24	18,8	43	43	25,2	50	75
34	24 <sup>e</sup>	19,5	46,5	46,5	25,2	52	75

NOTE t<sub>min</sub> is interpolated for sizes not covered by ISO 4032 and ISO 4014.

a t<sub>min</sub> = m<sub>max</sub> + 0,1; where m<sub>max</sub> is the maximum height of the nut, according to ISO 4032.

b d<sub>3min</sub> = Dmax × 1,05

c The maximum thread diameter Dmax is the largest nominal thread diameter found in current International Standards like, e.g. ISO 4014, ISO 4032, ISO 272.

d Nominal dimension not covered by ISO 272.

e Value determined in order to avoid reduction in hole clearance size.

**Table 4 — Square drive of 20**

s	Dmax <sup>c</sup> mm	t <sup>a</sup> min. mm	d <sub>1</sub> max. mm	d <sub>2</sub> max. mm	d <sub>3b</sub> <sup>b</sup> min.	l	
					Bolt clearance hole mm	max. Type A (normal) mm	min. Type B (long) mm
21	16	12,9	32,1	40	16,8	55	85
22 <sup>d</sup>	16	13,9	33,3	40	16,8	55	85
24	16	14,9	35,8	40	16,8	55	85
27	20	15,9	39,6	40	21,0	60	85
30	20	18,1	43,3	43,3	21,0	60	85
32 <sup>d</sup>	24	18,8	45,8	45,8	25,2	60	85
34	24 <sup>e</sup>	19,5	48,3	48,3	25,2	65	85
36	24	21,6	50,8	50,8	25,2	67	85
41	27	23,9	57,1	57,1	28,4	70	85
46	30	25,7	63,3	63,3	31,5	83	100
50	33	28,8	68,3	68,3	34,7	89	100
55	36	31,1	74,6	74,6	37,8	95	100
60	39	33,5	84,5	84,5	41,0	100	100

NOTE t<sub>min</sub> is interpolated for sizes not covered by ISO 4032 and ISO 4014.

a t<sub>min</sub> = m<sub>max</sub> + 0,1; where m<sub>max</sub> is the maximum height of the nut, according to ISO 4032.

b d<sub>3min</sub> = Dmax × 1,05

c The maximum thread diameter Dmax is the largest nominal thread diameter found in current International Standards like, e.g. ISO 4014, ISO 4032, ISO 272.

d Nominal dimension not covered by ISO 272.

e Value determined in order to avoid reduction in hole clearance size.

Table 5 — Square drive of 25

s	Dmax <sup>c</sup>	t <sup>a</sup> min.	d <sub>1</sub> max.	d <sub>2</sub> max.	d <sub>3b</sub> min.	l
					Bolt clearance hole	max
						Type A (normal)
mm	mm	mm	mm	mm	mm	
41	27	23,9	61	59,7	28,4	83
46	30	25,7	66,4	55	31,5	80
50	33	28,8	71,4	55	34,7	85
55	36	31,1	77,6	57	37,8	95
60	39	33,5	83,9	61	41,0	103
65	42	34,1	90,1	78	44,1	110
70	45	36,1	96,5	84	47,3	116

NOTE  $t_{\min}$  is interpolated for sizes not covered by ISO 4032 and ISO 4014.

a  $t_{\min} = m_{\max} + 0,1$ ; where  $m_{\max}$  is the maximum height of the nut, according to ISO 4032.

b  $d_{3\min} = D_{\max} \times 1,05$

c The maximum thread diameter  $D_{\max}$  is the largest nominal thread diameter found in current International Standards like, e.g. ISO 4014, ISO 4032, ISO 272.

## 5 Technical specifications

The technical specifications shall be in accordance with ISO 1711-1.

## 6 Designation

A hand-operated square drive socket in accordance with this part of ISO 2725 shall be designated by

- “Hex socket” or “Bi-hex socket”, depending on its form,
- reference to this part of ISO 2725 (i.e. ISO 2725-1),
- square drive dimensions, in millimetre,
- width across flats, in millimetre, and
- type.

EXAMPLE A double hexagon hand-operated square drive socket with 12,5 mm square size and width across flats  $s = 10$  mm, normal Type A, is designated as follows:

Bi-hex socket ISO 2725-1 - 12,5 × 10 - A

## 7 Marking

The hand-operated square drive socket shall be marked, permanently and legibly, with at least the following information:

- the name or trademark of the manufacturer or supplier;
- the width across flats.

## Bibliography

- [1] ISO 272, *Fasteners — Hexagon products — Widths across flats*
- [2] ISO 1703, *Assembly tools for screws and nuts — Designation and nomenclature*
- [3] ISO 2725-2, *Assembly tools for screws and nuts — Square drive sockets — Part 2: Machine-operated sockets (“impact”)*









# British Standards Institution (BSI)

BSI is the national body responsible for preparing British Standards and other standards-related publications, information and services.

BSI is incorporated by Royal Charter. British Standards and other standardization products are published by BSI Standards Limited.

## About us

We bring together business, industry, government, consumers, innovators and others to shape their combined experience and expertise into standards-based solutions.

The knowledge embodied in our standards has been carefully assembled in a dependable format and refined through our open consultation process. Organizations of all sizes and across all sectors choose standards to help them achieve their goals.

## Information on standards

We can provide you with the knowledge that your organization needs to succeed. Find out more about British Standards by visiting our website at [bsigroup.com/standards](http://bsigroup.com/standards) or contacting our Customer Services team or Knowledge Centre.

## Buying standards

You can buy and download PDF versions of BSI publications, including British and adopted European and international standards, through our website at [bsigroup.com/shop](http://bsigroup.com/shop), where hard copies can also be purchased.

If you need international and foreign standards from other Standards Development Organizations, hard copies can be ordered from our Customer Services team.

## Subscriptions

Our range of subscription services are designed to make using standards easier for you. For further information on our subscription products go to [bsigroup.com/subscriptions](http://bsigroup.com/subscriptions).

With **British Standards Online (BSOL)** you'll have instant access to over 55,000 British and adopted European and international standards from your desktop. It's available 24/7 and is refreshed daily so you'll always be up to date.

You can keep in touch with standards developments and receive substantial discounts on the purchase price of standards, both in single copy and subscription format, by becoming a **BSI Subscribing Member**.

**PLUS** is an updating service exclusive to BSI Subscribing Members. You will automatically receive the latest hard copy of your standards when they're revised or replaced.

To find out more about becoming a BSI Subscribing Member and the benefits of membership, please visit [bsigroup.com/shop](http://bsigroup.com/shop).

With a **Multi-User Network Licence (MUNL)** you are able to host standards publications on your intranet. Licences can cover as few or as many users as you wish. With updates supplied as soon as they're available, you can be sure your documentation is current. For further information, email [bsmusales@bsigroup.com](mailto:bsmusales@bsigroup.com).

## Revisions

Our British Standards and other publications are updated by amendment or revision.

We continually improve the quality of our products and services to benefit your business. If you find an inaccuracy or ambiguity within a British Standard or other BSI publication please inform the Knowledge Centre.

## Copyright

All the data, software and documentation set out in all British Standards and other BSI publications are the property of and copyrighted by BSI, or some person or entity that owns copyright in the information used (such as the international standardization bodies) and has formally licensed such information to BSI for commercial publication and use. Except as permitted under the Copyright, Designs and Patents Act 1988 no extract may be reproduced, stored in a retrieval system or transmitted in any form or by any means – electronic, photocopying, recording or otherwise – without prior written permission from BSI. Details and advice can be obtained from the Copyright & Licensing Department.

## Useful Contacts:

### Customer Services

**Tel:** +44 845 086 9001

**Email (orders):** [orders@bsigroup.com](mailto:orders@bsigroup.com)

**Email (enquiries):** [cservices@bsigroup.com](mailto:cservices@bsigroup.com)

### Subscriptions

**Tel:** +44 845 086 9001

**Email:** [subscriptions@bsigroup.com](mailto:subscriptions@bsigroup.com)

### Knowledge Centre

**Tel:** +44 20 8996 7004

**Email:** [knowledgecentre@bsigroup.com](mailto:knowledgecentre@bsigroup.com)

### Copyright & Licensing

**Tel:** +44 20 8996 7070

**Email:** [copyright@bsigroup.com](mailto:copyright@bsigroup.com)

## BSI Group Headquarters

389 Chiswick High Road London W4 4AL UK



...making excellence a habit.™