

BS ISO 2559:2011



BSI Standards Publication

Textile glass — Mats (made from chopped or continuous strands) — Designation and basis for specifications

bsi.

...making excellence a habit.™

National foreword

This British Standard is the UK implementation of ISO 2559:2011. It supersedes BS ISO 2559:2000 which is withdrawn.

The UK participation in its preparation was entrusted to Technical Committee PRI/42, Fibre reinforced thermosetting plastics and prepregs.

A list of organizations represented on this committee can be obtained on request to its secretary.

This publication does not purport to include all the necessary provisions of a contract. Users are responsible for its correct application.

© BSI 2011

ISBN 978 0 580 74661 1

ICS 59.100.10

Compliance with a British Standard cannot confer immunity from legal obligations.

This British Standard was published under the authority of the Standards Policy and Strategy Committee on 31 December 2011.

Amendments issued since publication

| Date | Text affected |
|------|---------------|
|------|---------------|

**Textile glass — Mats (made from chopped
or continuous strands) — Designation
and basis for specifications**

*Verre textile — Mats (constitués de fils de base, coupés ou non) —
Désignation et base de spécifications*





COPYRIGHT PROTECTED DOCUMENT

© ISO 2011

All rights reserved. Unless otherwise specified, no part of this publication may be reproduced or utilized in any form or by any means, electronic or mechanical, including photocopying and microfilm, without permission in writing from either ISO at the address below or ISO's member body in the country of the requester.

ISO copyright office
Case postale 56 • CH-1211 Geneva 20
Tel. + 41 22 749 01 11
Fax + 41 22 749 09 47
E-mail copyright@iso.org
Web www.iso.org

Published in Switzerland

Foreword

ISO (the International Organization for Standardization) is a worldwide federation of national standards bodies (ISO member bodies). The work of preparing International Standards is normally carried out through ISO technical committees. Each member body interested in a subject for which a technical committee has been established has the right to be represented on that committee. International organizations, governmental and non-governmental, in liaison with ISO, also take part in the work. ISO collaborates closely with the International Electrotechnical Commission (IEC) on all matters of electrotechnical standardization.

International Standards are drafted in accordance with the rules given in the ISO/IEC Directives, Part 2.

The main task of technical committees is to prepare International Standards. Draft International Standards adopted by the technical committees are circulated to the member bodies for voting. Publication as an International Standard requires approval by at least 75 % of the member bodies casting a vote.

Attention is drawn to the possibility that some of the elements of this document may be the subject of patent rights. ISO shall not be held responsible for identifying any or all such patent rights.

ISO 2559 was prepared by Technical Committee ISO/TC 61, *Plastics*, Subcommittee SC 13, *Composites and reinforcement fibres*.

This fifth edition cancels and replaces the fourth edition (ISO 2559:2000), of which it constitutes a minor revision. Clause 7 has been rewritten to eliminate the reference to ISO 1886, which has been withdrawn.

Textile glass — Mats (made from chopped or continuous strands) — Designation and basis for specifications

1 Scope

This International Standard provides a basis for specifications which is applicable only to textile glass mats that are made from chopped or continuous strands bonded together by chemical or mechanical means and that are used for the reinforcement of plastics.

It is not applicable to surfacing mats, staple-fibre mats or glass mats (or bats) of the type used for thermal and acoustic insulation.

2 Normative references

The following referenced documents are indispensable for the application of this document. For dated references, only the edition cited applies. For undated references, the latest edition of the referenced document (including any amendments) applies.

ISO 291, *Plastics — Standard atmospheres for conditioning and testing*

ISO 472, *Plastics — Vocabulary*

ISO 1887, *Textile glass — Determination of combustible-matter content*

ISO 1888, *Textile glass — Staple fibres or filaments — Determination of average diameter*

ISO 2078, *Textile glass — Yarns — Designation*

ISO 2558, *Textile glass chopped-strand mats for reinforcement of plastics — Determination of time of dissolution of the binder in styrene*

ISO 3342, *Textile glass — Mats — Determination of tensile breaking force*

ISO 3374, *Reinforcement products — Mats and fabrics — Determination of mass per unit area*

ISO 3616, *Textile glass — Chopped-strand and continuous-filament mats — Determination of average thickness, thickness under load and recovery after compression*

ISO 5025, *Reinforcement products — Woven fabrics — Determination of width and length*

3 Terms and definitions

For the purposes of this document, the terms and definitions given in ISO 472 and the following apply.

3.1

characteristic properties

properties not normally subject to routine quality control in the mat production process

3.2

controlled properties

quantitative properties subject to routine quality control in the mat production process

3.3

visual properties

qualitative properties not necessarily subject to routine quality control in the mat production process

4 Technical requirements

4.1 General

A given mat shall be designed so as to satisfy the requirements of one or several applications. Essentially, a specific mat is chosen so as to bring to the laminate its reinforcement properties under certain environmental conditions, which may range from a dry inert to a wet corrosive atmosphere.

The expected product performance properties are generally not guaranteed as such due to the difficulty in standardizing the conditions under which the mat is used (resin mix, cure system, laminate structure, glass/resin/filler ratio, etc.). For this reason, the mat will be characterized in the specification by other guaranteed properties which can be correlated with the desired practical laminating properties. The latter can be divided into characteristic, controlled and visual properties, as defined in Clause 3.

Where required, the controlled properties (measured parameters) may be stated on certificates of conformity or other quality control test reports.

The following is a proposed list of “characteristic” and “controlled” properties with, when applicable, the relevant test method. The distinction between characteristic and controlled properties is indicative only, and may vary for different mat products.

The specification for a given mat shall include the relevant properties among those listed hereafter, with tolerances where applicable.

4.2 Characteristic properties

4.2.1 Resin compatibility

The resin(s) recommended for use with the mat.

4.2.2 Glass type

The glass type as defined in ISO 2078.

4.2.3 Filament diameter

The average diameter of the filaments constituting the strands in the mat. If necessary, the average filament diameter may be determined in accordance with ISO 1888.

4.2.4 Strand linear density

It is not normally possible to determine the linear density of the strands in the mat since they might have been split and/or chopped during the production process. Therefore the figure quoted is usually that of the input strand, the linear density of which can only be determined by the mat manufacturer.

4.2.5 Strand length

The length of the strands, which may be either unchopped (continuous-filament mat) or chopped to a given length, with the possibility of a mix of different specified lengths (chopped-strand mat).

4.2.6 Size type

The type of size (essentially the type of coupling agent) used to coat the filaments.

4.2.7 Bonding system

The system used to bond the strands, which may be

- either of a chemical type, e.g. a liquid binder (emulsion) or a solid binder (powder),

- or of a mechanical type, with or without carrier (if a carrier is used, it shall be identified).

4.2.8 Width

The width of the mat, expressed in centimetres or millimetres. For mats with trimmed edges, the width may be determined by the method given for woven fabrics in ISO 5025. For mats with untrimmed edges, the method given in Annex A may be used.

4.2.9 Edges

The nature of the edges of the mat, which may be

- either untrimmed (feathered) on one or both sides;
- or trimmed on both sides.

In the case of mats untrimmed along one or both edges, the width shall be measured between two points where the thickness of the mat does not visibly vary. For such mats, the tolerances on the width shall be agreed upon between the interested parties.

4.2.10 Length

The length of the material in a roll. The specification may allow the length to vary between rolls or to be fixed within agreed tolerances. Moreover, it is possible that a shipment incorporates incomplete rolls. The number, the mass or the minimum length of the incomplete rolls shall be specified.

4.2.11 Degree of solubility of chopped-strand mat binder in styrene

The solubility of the mat binder in styrene shall be determined in accordance with ISO 2558. It is generally expressed as high (<60 s), medium (60 s to 200 s) or low (>200 s), depending on the result obtained using this method.

4.3 Controlled properties

4.3.1 Mass per unit area

The mass per unit area shall be determined in accordance with ISO 3374 and expressed in grams per square metre. This mass includes the glass strands, the size and the binder(s) plus any carrier present.

For each type of mat, the manufacturer shall give a nominal value of the mass per unit area and shall define the tolerances on the measured values, specifying if the tolerances apply to the average of the test specimens taken across the width of the mat or to each test specimen.

NOTE The most common nominal values are 300 g/m², 375 g/m², 450 g/m² and 600 g/m².

4.3.2 Percentage combustible matter

The percentage of combustible matter shall be determined in accordance with ISO 1887. The combustible matter corresponds to the sum of the size applied to the filaments and the binder(s) applied to the strands. In the case of mats bonded mechanically with an organic-fibre carrier, the mass of the carrier would be included in the combustible-matter content.

The tolerances given in the specification shall be related to the average for test specimens taken across the width of the mat, unless otherwise agreed upon between purchaser and supplier.

4.3.3 Tensile strength

The dry tensile strength of the mat shall be determined in accordance with ISO 3342, which includes two types of specimen depending on the type of mat being tested. The type of test specimen to be used shall be stated in the specification.

4.3.4 Thickness

The thickness of the mat shall be determined in accordance with ISO 3616.

4.4 Visual properties

The mat shall be uniform in appearance. The roll shall be wound with appropriate compaction and the edges aligned so that telescoping does not exceed a given tolerance, agreed between purchaser and supplier.

Listed below are a number of recognized visible non-conformities which might exist in a mat, and which can occur during manufacture or during subsequent handling:

- tears;
- holes;
- dirt marks;
- grease spots;
- foreign matter;
- clumps of strands;
- clumps or strips of binder;
- dark strands;
- locally thin areas;
- locally poorly bonded areas;
- irregular edges.

The permissible number and extent of these and/or other visible non-conformities shall be agreed between the interested parties.

5 Designation

The designation of the mat shall be one of the following elements:

- Block 1: mat type (chopped strand or continuous filament).
- Block 2: mass per unit area, width.
- Block 3: binder type (powder or emulsion), strand length(s) and tex.

This designation is generally preceded by the commercial name given by the manufacturer and followed by coded information concerning the trimmed edges or any other information specific to the relevant mat.

6 Labelling

Each roll of mat and each pallet shall bear a label indicating the manufacturer's name, the type of mat and any data needed to ensure material traceability (such as roll number, mass, length or production date).

7 Sampling and conditioning

Select, from each delivery of a given type of mat, a suitable number of rolls. Unroll the outer layer of each roll selected, ensuring that any damaged sections are removed. Then take, from the whole width, a laboratory sample of sufficient length to enable all the required test specimens to be cut out, as specified in the applicable test methods.

Condition the laboratory sample for at least 1 h in one of the standard atmospheres specified in ISO 291, unless another atmosphere is required by the particular nature of the product.

8 Presentation, packaging and storage conditions

Requirements concerning the presentation, packaging and storage conditions shall be given.

Annex A (informative)

Determination of the width of an untrimmed mat

A.1 General

The method described below may be used in cases of dispute between the interested parties.

A.2 Mats untrimmed along one edge

Cut, from the whole width of the mat, a 30-cm-wide strip. From the strip, cut a rectangular specimen measuring $50\text{ cm} \pm 5\text{ cm}$ and including the untrimmed edge (see Figure A.1).

Place the specimen between two vertical guides approximately 10 mm apart, with the untrimmed edge lowermost. Measure the vertical height h (see Figure A.2).

Measure directly (in the case of a mat trimmed along both edges, see Clause A.3) the length b of the remaining portion of the strip.

The width of the mat is $h + b$.

A.3 Mats untrimmed along both edges

Proceed as in Clause A.2, but cut from each edge of the strip a specimen measuring $50\text{ cm} \pm 5\text{ cm}$ and including an untrimmed edge.

Measure the vertical heights h_1 and h_2 of each of these specimens.

Measure the length b of the remaining portion of the strip.

The width of the mat is $h_1 + h_2 + b$.

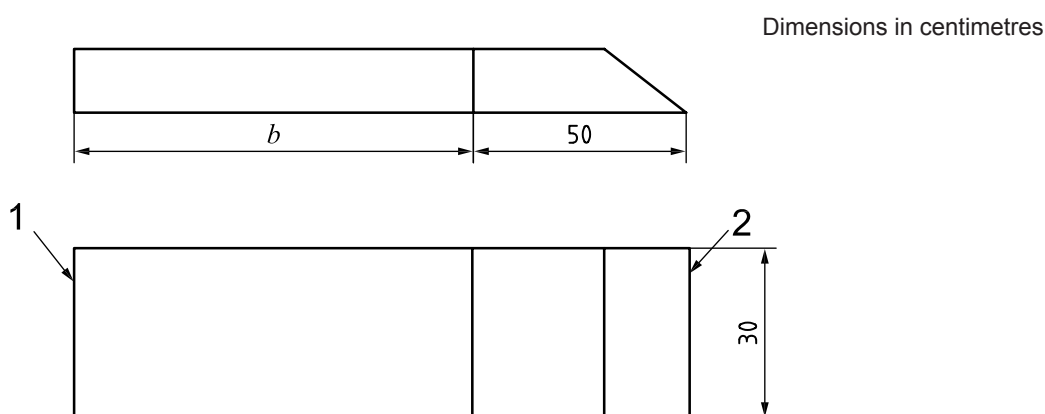

Key

- 1 trimmed edge
- 2 untrimmed edge

Figure A.1 — Strip cut from whole width of mat

Dimensions in millimetres

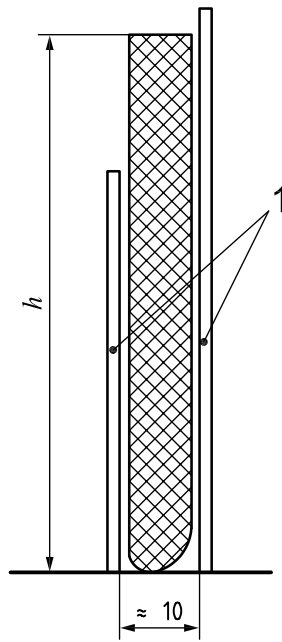

Key

1 vertical guides

Figure A.2 — Specimen holder

ICS 59.100.10

Price based on 7 pages

British Standards Institution (BSI)

BSI is the national body responsible for preparing British Standards and other standards-related publications, information and services.

BSI is incorporated by Royal Charter. British Standards and other standardization products are published by BSI Standards Limited.

About us

We bring together business, industry, government, consumers, innovators and others to shape their combined experience and expertise into standards-based solutions.

The knowledge embodied in our standards has been carefully assembled in a dependable format and refined through our open consultation process. Organizations of all sizes and across all sectors choose standards to help them achieve their goals.

Information on standards

We can provide you with the knowledge that your organization needs to succeed. Find out more about British Standards by visiting our website at bsigroup.com/standards or contacting our Customer Services team or Knowledge Centre.

Buying standards

You can buy and download PDF versions of BSI publications, including British and adopted European and international standards, through our website at bsigroup.com/shop, where hard copies can also be purchased.

If you need international and foreign standards from other Standards Development Organizations, hard copies can be ordered from our Customer Services team.

Subscriptions

Our range of subscription services are designed to make using standards easier for you. For further information on our subscription products go to bsigroup.com/subscriptions.

With **British Standards Online (BSOL)** you'll have instant access to over 55,000 British and adopted European and international standards from your desktop. It's available 24/7 and is refreshed daily so you'll always be up to date.

You can keep in touch with standards developments and receive substantial discounts on the purchase price of standards, both in single copy and subscription format, by becoming a **BSI Subscribing Member**.

PLUS is an updating service exclusive to BSI Subscribing Members. You will automatically receive the latest hard copy of your standards when they're revised or replaced.

To find out more about becoming a BSI Subscribing Member and the benefits of membership, please visit bsigroup.com/shop.

With a **Multi-User Network Licence (MUNL)** you are able to host standards publications on your intranet. Licences can cover as few or as many users as you wish. With updates supplied as soon as they're available, you can be sure your documentation is current. For further information, email bsmusales@bsigroup.com.

BSI Group Headquarters

389 Chiswick High Road London W4 4AL UK

Revisions

Our British Standards and other publications are updated by amendment or revision.

We continually improve the quality of our products and services to benefit your business. If you find an inaccuracy or ambiguity within a British Standard or other BSI publication please inform the Knowledge Centre.

Copyright

All the data, software and documentation set out in all British Standards and other BSI publications are the property of and copyrighted by BSI, or some person or entity that owns copyright in the information used (such as the international standardization bodies) and has formally licensed such information to BSI for commercial publication and use. Except as permitted under the Copyright, Designs and Patents Act 1988 no extract may be reproduced, stored in a retrieval system or transmitted in any form or by any means – electronic, photocopying, recording or otherwise – without prior written permission from BSI. Details and advice can be obtained from the Copyright & Licensing Department.

Useful Contacts:

Customer Services

Tel: +44 845 086 9001

Email (orders): orders@bsigroup.com

Email (enquiries): cservices@bsigroup.com

Subscriptions

Tel: +44 845 086 9001

Email: subscriptions@bsigroup.com

Knowledge Centre

Tel: +44 20 8996 7004

Email: knowledgecentre@bsigroup.com

Copyright & Licensing

Tel: +44 20 8996 7070

Email: copyright@bsigroup.com



...making excellence a habit.™