

BS ISO 2393:2014

Incorporating corrigendum September 2015



BSI Standards Publication

Rubber test mixes — Preparation, mixing and vulcanization — Equipment and procedures

bsi.

...making excellence a habit.™

National foreword

This British Standard is the UK implementation of ISO 2393:2014. It supersedes BS ISO 2393:2008 which is withdrawn.

The UK participation in its preparation was entrusted to Technical Committee PRI/22, Physical testing of rubber.

A list of organizations represented on this committee can be obtained on request to its secretary.

This publication does not purport to include all the necessary provisions of a contract. Users are responsible for its correct application.

© The British Standards Institution 2015. Published by BSI Standards Limited 2015

ISBN 978 0 580 91435 5

ICS 83.060

Compliance with a British Standard cannot confer immunity from legal obligations.

This British Standard was published under the authority of the Standards Policy and Strategy Committee on 31 March 2014.

Amendments/corrigenda issued since publication

Date	Text affected
30 September 2015	Implementation of ISO corrected text 01 April 2014: Numbering of subdivisions of subclauses amended, see ISO Foreword for details

Fourth edition
2014-03-01

Corrected version
2014-04-01

**Rubber test mixes — Preparation,
mixing and vulcanization —
Equipment and procedures**

*Mélanges d'essais à base de caoutchouc — Mélangeage, préparation
et vulcanisation — Appareillage et modes opératoires*



Reference number
ISO 2393:2014(E)

© ISO 2014



COPYRIGHT PROTECTED DOCUMENT

© ISO 2014

All rights reserved. Unless otherwise specified, no part of this publication may be reproduced or utilized otherwise in any form or by any means, electronic or mechanical, including photocopying, or posting on the internet or an intranet, without prior written permission. Permission can be requested from either ISO at the address below or ISO's member body in the country of the requester.

ISO copyright office
Case postale 56 • CH-1211 Geneva 20
Tel. + 41 22 749 01 11
Fax + 41 22 749 09 47
E-mail copyright@iso.org
Web www.iso.org

Published in Switzerland

Contents

Page

Foreword	iv
1 Scope	1
2 Normative references	1
3 Terms and definitions	1
4 Compounding ingredients	2
5 Preparation of materials	2
5.1 Batch masses	2
5.2 Weighing tolerances	2
5.3 Carbon black conditioning.....	2
6 Mixing equipment	2
6.1 Mixing mill	2
6.2 Laboratory internal mixer.....	3
7 Mixing procedures	4
7.1 General.....	4
7.2 Mill mixing procedure.....	4
7.3 Laboratory internal mixer mixing procedure	5
8 Preparation of standard vulcanized sheets for dumb-bell test pieces	7
8.1 Conditioning of batches and blank preparation.....	7
8.2 Vulcanization equipment	8
8.3 Vulcanization procedure.....	10
9 Preparation of standard vulcanized discs for ring test pieces	11
9.1 Conditioning of batches and blank preparation.....	11
9.2 Vulcanization equipment	11
9.3 Vulcanization procedure.....	12
10 Precision	12
Annex A (informative) Precision statement for both mill and internal mixer	14
Annex B (informative) Internal mixer parameters and operating conditions for the three interlaboratory test programmes	21
Annex C (informative) Further analysis of the ITP data	23
Bibliography	24

Foreword

ISO (the International Organization for Standardization) is a worldwide federation of national standards bodies (ISO member bodies). The work of preparing International Standards is normally carried out through ISO technical committees. Each member body interested in a subject for which a technical committee has been established has the right to be represented on that committee. International organizations, governmental and non-governmental, in liaison with ISO, also take part in the work. ISO collaborates closely with the International Electrotechnical Commission (IEC) on all matters of electrotechnical standardization.

The procedures used to develop this document and those intended for its further maintenance are described in the ISO/IEC Directives, Part 1. In particular the different approval criteria needed for the different types of ISO documents should be noted. This document was drafted in accordance with the editorial rules of the ISO/IEC Directives, Part 2 (see www.iso.org/directives).

Attention is drawn to the possibility that some of the elements of this document may be the subject of patent rights. ISO shall not be held responsible for identifying any or all such patent rights. Details of any patent rights identified during the development of the document will be in the Introduction and/or on the ISO list of patent declarations received (see www.iso.org/patents).

Any trade name used in this document is information given for the convenience of users and does not constitute an endorsement.

For an explanation on the meaning of ISO specific terms and expressions related to conformity assessment, as well as information about ISO's adherence to the WTO principles in the Technical Barriers to Trade (TBT) see the following URL: Foreword - Supplementary information

The committee responsible for this document is ISO/TC 45, *Rubber and rubber products*, Subcommittee SC 3, *Raw materials (including latex) for use in the rubber industry*.

This fourth edition cancels and replaces the third edition (ISO 2393:2008), which has been technically revised:

- [7.1](#) has been added stating that the Laboratory Internal Mixer is the preferred equipment;
- 7.2.1.1 has become [7.3.1.1](#); the subclause has been revised to delete the reference to EST8, which is no longer available, and because a control mix for a specific rubber type is not relevant in this International Standard;
- dimensions of the mould cavity have been specified in [8.2.2](#);
- instructions for removing trapped air after inserting the blanks have been added in [8.3.2](#).

This corrected version of ISO 2393:2014 incorporates the following corrections:

- reinstatement of the numbering of subdivisions of subclauses [5.1](#), [5.2](#), [6.2](#), [7.2](#), [7.3.1](#), [7.3.2](#), [7.3.3](#), [8.1](#), [8.3](#), [9.1](#).

Rubber test mixes — Preparation, mixing and vulcanization — Equipment and procedures

1 Scope

This International Standard specifies the equipment and procedures for the preparation, mixing, and vulcanization of rubber test mixes specified in the various International Standards for the evaluation of such test mixes.

2 Normative references

The following documents, in whole or in part, are normatively referenced in this document and are indispensable for its application. For dated references, only the edition cited applies. For undated references, the latest edition of the referenced document (including any amendments) applies.

ISO 37, *Rubber, vulcanized or thermoplastic — Determination of tensile stress-strain properties*

ISO 289-1, *Rubber, unvulcanized — Determinations using a shearing-disc viscometer — Part 1: Determination of Mooney viscosity*

ISO 23529, *Rubber — General procedures for preparing and conditioning test pieces for physical test methods*

3 Terms and definitions

For the purposes of this document, the following terms and definitions apply.

3.1

formulation batch mass

aggregate mass, in grams, of all the constituents in a formulation, with the rubber or oil-extended rubber polymer being taken as 100 g, or as specified in the appropriate evaluation procedure

3.2

batch mass

mass of test mix prepared in one mixing operation

3.3

total free volume

volume of the mixing chamber with the rotors in place

3.4

nominal mixer capacity

proportion of the total free volume which is used in the mixing process

Note 1 to entry: A value of 0,75 times the total free volume has been found suitable for mixers with tangential rotors.

3.5

evaluation procedure

International Standard specifying the materials, test formulation, mixing procedure, vulcanization procedure, and test methods for the evaluation of a type of rubber or compounding ingredient

4 Compounding ingredients

The compounding ingredients required for the various standard test formulations shall be in accordance with National or International Standards as specified in the appropriate evaluation procedure.

5 Preparation of materials

5.1 Batch masses

5.1.1 The standard batch mass for the laboratory mill, in grams, shall be four times the formulation batch mass unless otherwise stated in the appropriate evaluation procedure.

NOTE Smaller batch masses are used in some countries. These may not give identical results.

5.1.2 The batch mass for the laboratory internal mixer, in grams, shall be equal to the nominal mixer capacity, in cubic centimetres, multiplied by the compound density.

5.2 Weighing tolerances

5.2.1 The batch mass shall be taken into consideration when determining weighing tolerances. In general, rubber and carbon black shall be weighed to the nearest 1 g, oil to the nearest 1 g or $\pm 1\%$, whichever is the more accurate, vulcanizing agents and accelerators to the nearest 0,02 g and zinc oxide and stearic acid to the nearest 0,1 g. All other ingredients shall be weighed to an accuracy of $\pm 1\%$.

5.2.2 When the batch mass is less than four times the formulation batch mass, the weighing tolerances shall be one tenth of those given in [5.2.1](#). Therefore, the rubber and carbon black shall be weighed to the nearest 0,1 g, oil to the nearest 0,1 g or $\pm 1\%$ whichever is the more accurate, sulfur and accelerators to the nearest 0,002 g and zinc oxide and stearic acid to the nearest 0,01 g. All other ingredients shall be weighed to an accuracy of $\pm 1\%$.

5.3 Carbon black conditioning

Unless otherwise specified, carbon black shall be conditioned, before weighing, by heating in an oven at a temperature of $105\text{ }^{\circ}\text{C} \pm 5\text{ }^{\circ}\text{C}$ for 2 h. The black shall be placed in an open vessel of suitable dimensions, so that the depth of the black is no more than 10 mm during conditioning. The black, conditioned as above, shall be stored in a closed moisture-proof container until it is required for mixing.

Alternatively, carbon black may be conditioned by heating in an oven at $125\text{ }^{\circ}\text{C} \pm 3\text{ }^{\circ}\text{C}$ for 1 h. Carbon black conditioned in this manner may not give the same results as that conditioned at $105\text{ }^{\circ}\text{C} \pm 5\text{ }^{\circ}\text{C}$.

The conditioning temperature used shall be recorded in the batch-mixing report.

6 Mixing equipment

6.1 Mixing mill

The characteristics of a standard laboratory mill are as follows:

- roll diameter (OD) 150 mm to 155 mm;
- roll length (between guides) 250 mm to 280 mm;
- speed of front (slow) roll 24 r/min \pm 1 r/min;
- roll-speed ratio preferably 1:1,4;
- clearance between rolls (adjustable) 0,2 mm to 8,0 mm;

— temperature-control tolerance $\pm 5\text{ }^{\circ}\text{C}$ (unless otherwise specified).

WARNING — The mill should be equipped with suitable safety devices to protect against accidents and the operator should be provided with suitable equipment to protect against hazardous chemicals, in accordance with national safety regulations.

NOTE 1 If mills of other dimensions are used, adjustments to batch masses and mixing cycles may be required to obtain comparable results.

NOTE 2 If the roll-speed ratio is other than 1:1,4, modifications may be necessary to the mixing procedure to obtain comparable results.

The roll clearance shall be determined by means of two lead strips 10 mm \pm 3 mm in width, at least 50 mm long and 0,25 mm to 0,50 mm thicker than the roll clearance to be measured. The lead strips shall be inserted, one at each end of the rolls, approximately 25 mm from the guides, while a piece of compounded rubber with a Mooney viscosity, determined in accordance with ISO 289-1, greater than 50 ML(1+4) at 100 $^{\circ}\text{C}$ and measuring approximately 75 mm \times 75 mm \times 6 mm is passing through the centre portion of the nip. The rolls shall be at the temperature specified for mixing. After passing between the rolls, the thickness of the lead strips shall be measured at three separate positions with a micrometer to an accuracy of $\pm 0,01$ mm. The tolerance on roll clearance shall be $\pm 10\%$ or 0,05 mm, whichever is the larger.

The mill rolls shall have provision for circulation of heating or cooling media.

6.2 Laboratory internal mixer

6.2.1 Laboratory internal mixers are available in a variety of sizes ranging from a nominal mixer capacity of 65 cm³ (described previously as a miniature internal mixer) to about 3 000 cm³. Interlaboratory test programmes (ITPs) on two different types of synthetic rubber and on natural rubber have shown that mixer capacity does not have a significant effect on the results, provided that good dispersion of all ingredients is achieved (see [Annex C](#) for a discussion of the effects of certain mixer variables).

For interlaboratory comparisons, it is preferable to use the same type of mixer and to align the mixing conditions (nominal mixing capacity, mixer head starting temperature, rotor type, and speed, mixing time) as closely as possible.

All of the mixers used in the interlaboratory test programmes (ITPs) were of the tangential-rotor type, and included Banbury, cam, and other types. No laboratory suggested using an intermeshing-rotor mixer. Therefore, the mixer described as type B in the previous edition of this International Standard has been deleted. However, an intermeshing type may be used when the interested parties agree.

6.2.2 This International Standard describes general requirements for laboratory internal mixers ranging in nominal mixer capacity from about 65 cm³ to about 2 000 cm³.

WARNING — Laboratory internal mixers should be equipped with a suitable exhaust system and suitable safety devices to prevent accidents, in accordance with national safety regulations. The operators should be provided with suitable equipment to protect them against hazardous chemicals, in accordance with national regulations.

NOTE The smaller laboratory internal mixers can only provide enough compound for curemeter testing and limited stress-strain testing.

6.2.3 All laboratory internal mixers shall be fitted with a system to measure and indicate and/or record the temperature of the mix during the mixing operation to within 1 $^{\circ}\text{C}$.

NOTE The actual mix temperature usually exceeds the indicated temperatures by an amount dependent on the mixing conditions used and the location of the measuring probe.

6.2.4 All laboratory internal mixers shall be fitted with a timer to indicate the mixing time to ± 5 s.

6.2.5 All laboratory internal mixers shall be fitted with a system to indicate or record electrical power demand or torque.

6.2.6 All laboratory internal mixers shall be fitted with an efficient heating and cooling system to control the surface temperature of the rotors and the mixing-chamber walls.

6.2.7 All laboratory internal mixers shall be closed during the mixing cycle with a ram to contain the mix in the mixing chamber.

6.2.8 When rotor clearances exceed the “as delivered” values by approximately 50 %, an overhaul is deemed necessary since mixing quality may be adversely affected. This increase in rotor clearance may be equated to an approximately 10 % increase in nominal mixer capacity.

6.2.9 A mill as described in [6.1](#) shall be provided for consolidating mixes.

6.2.10 The smallest laboratory internal mixer can be fitted with rotors of different types, resulting in different nominal mixer capacities (see [Table 1](#)).

Table 1 — Rotor types for smallest laboratory internal mixer

Parameter	Cam	Banbury
Total free volume (cm ³)	85 ± 1	75 ± 1
Nominal mixer capacity (cm ³)	64	56
Rotor friction ratio	1,5:1	1,5:1

7 Mixing procedures

7.1 General

The Laboratory Internal Mixer is preferred over the laboratory mill

7.2 Mill mixing procedure

7.2.1 Batches shall be mixed with the rubber banded on the front roll, unless otherwise specified in the appropriate evaluation procedure.

7.2.2 The temperature at the middle of the surface of the rolls shall be measured during the mixing procedure, either continuously on a recorder or frequently enough with a manual device (having an accuracy of ±1 °C or better) to be sure that the desired temperature is being maintained. The batch may be removed momentarily from the mill to enable the surface temperature of the front roll to be measured.

7.2.3 Whenever 3/4 cuts are specified, the batch shall be cut 3/4 of the distance across the roll and the knife held in this position until the bank just disappears.

7.2.4 The compounding ingredients shall be introduced along the whole roll length. The batch shall not be cut while free powder is evident on the rolling bank or on the milling surface. Compounding ingredients falling through the nip shall be carefully collected and returned to the batch.

7.2.5 Whenever 3/4 cuts each way are specified, successive 3/4 cuts shall be made from alternate directions, allowing 20 s between successive cuts unless otherwise specified in the appropriate evaluation procedure.

7.2.6 Pass the rolled batch endwise through the mill six times unless otherwise specified in the appropriate evaluation procedure.

7.2.7 The mass of the mixed batch shall not differ from the total mass of the ingredients by more than +0,5 % or -1,5 %.

Some rubbers and compounding ingredients contain small amounts of volatiles which may be lost at the temperature of mixing, with the result that the above limit may not be met. In such cases, the difference shall be reported and justified.

7.2.8 The mixed batch shall be cooled to room temperature on a flat, clean, dry, metal surface. Alternatively, the mixed batch may be cooled in water, but different results may be obtained.

The cooled batches shall be wrapped in aluminium foil or other suitable material to prevent contamination by other compounds.

7.2.9 A report shall be prepared for each batch mixed, indicating

- a) the roll-speed ratio (friction ratio) and roll speeds,
- b) the distance between the guides,
- c) the maximum and minimum roll temperatures recorded during the mixing procedure,
- d) the temperature used for conditioning the carbon black,
- e) the method of cooling the mixed batch,
- f) any mass loss greater than the limits given in [7.2.7](#), with the reason for acceptance, and
- g) the number of the International Standard specifying the evaluation procedure in which the test mix is to be used.

7.3 Laboratory internal mixer mixing procedure

7.3.1 General

7.3.1.1 The mixing technique used shall be such as to achieve good dispersion of all the ingredients.

It is not possible to state in this International Standard whether a single or two stage mixing procedure is preferred. Reference shall be made to the relevant rubber evaluation procedure.

Where a technique is given in a particular evaluation procedure, it is permissible to make changes to the technique to ensure good dispersion.

NOTE The ITP data in [Annex A](#) shows that both single and two stage mixing procedures give equivalent results for the rubber types evaluated, namely ESBR, BR, and NR.

7.3.1.2 For each batch mixed, the laboratory internal mixer conditions shall be the same during the preparation of a series of identical mixes. At the beginning of each series of rubber test mixes, a machine-conditioning batch shall be mixed using the same formulation as in the mixes under test. This also acts as a machine-cleaning batch. The laboratory internal mixer shall be allowed to cool down to a specified temperature between the end of one test batch and the start of the next. Temperature control conditions shall not be altered during the mixing of a series of test batches.

7.3.1.3 Material to be mixed shall be reduced in size to pieces that can be fed easily and rapidly to the laboratory internal mixer.

7.3.2 Two-stage mixing procedure

7.3.2.1 The discharged batch shall be consolidated on a standard laboratory mill in the manner specified in the appropriate evaluation procedure and allowed to cool to room temperature on a flat, clean, dry, metal surface.

7.3.2.2 The mass of the mixed batch shall not differ from the total mass of the ingredients by more than +0,5 % or -1,5 %.

Some rubbers and compounding ingredients are known to contain small amounts of volatiles which can be lost at the temperatures of mixing, with the result that the above limit cannot be met. In such cases, the difference shall be reported and justified. This also applies to [7.3.2.5](#) and [7.3.3.1](#).

7.3.2.3 Rest the batch for at least 30 min, or until it reaches room temperature, before proceeding with the final mixing stage. The maximum time between mixing stages shall be 24 h.

7.3.2.4 If the final-stage mix is to be prepared in the internal mixer, cut the batch from the first stage into strips for easier feeding and add the remaining ingredients in accordance with the instructions in the appropriate evaluation procedure.

If the final stage is to be prepared on the mill, add the ingredients in accordance with the instructions in the appropriate evaluation procedure.

Unless otherwise stated, the batch size shall be reduced to four times the formulation batch mass.

7.3.2.5 When the laboratory internal mixer is used for the final stage, the discharged batch shall be consolidated as in [7.3.2.1](#).

The mass of the mixed batch shall not differ from the total mass of the ingredients by more than +0,5 % or -1,5 %.

7.3.2.6 Remove a curemeter test piece and (if required) a compound viscosity test piece from the batch. Then pass the batch four times through the mill at a roll temperature of $50\text{ °C} \pm 5\text{ °C}$, unless otherwise stated in the appropriate evaluation procedure. Fold the batch lengthwise after each pass, and pass always in the same direction to obtain a grain effect. The mill opening shall be such as to give a sheet between 2,1 mm and 2,5 mm thick after shrinkage, suitable for the preparation of vulcanized sheets for dumb-bell test pieces. If vulcanized discs for ring test pieces are to be prepared, open the mill so that a sheet between 4,1 mm and 4,5 mm thick is produced.

7.3.2.7 A report shall be prepared for each batch mixed, indicating

- a) the mixer head starting temperature,
- b) the mixing time,
- c) the rotor speed,
- d) the ram pressure,
- e) the temperature of the mix at discharge,
- f) the mixing technique — order of adding ingredients, times, etc.,
- g) the type of mixer used — size, rotor type, etc.,
- h) any allowable mass loss outside the limits given in [7.3.2.2](#) and [7.3.2.5](#), with the reason for acceptance,
- i) the temperature used for conditioning the carbon black, and
- j) the number of the International Standard specifying the evaluation procedure in which the test mix is to be used.

For mixes where both initial and final stages are carried out in the internal mixer, a report shall be issued for each of the two stages.

For mixes where the final stage is carried out on the mill, the procedure given in 7.1 shall be used and a separate report prepared in accordance with 7.2.9 with the exception of the carbon black conditioning temperature.

7.3.3 Single-stage mixing procedure

7.3.3.1 The discharged batch shall be consolidated as in 7.3.2.1. The mass of the mixed batch shall not differ from the total mass of the ingredients by more than +0,5 % or -1,5 %.

7.3.3.2 Carry out the procedure as given in 7.3.2.6, unless otherwise stated in the appropriate evaluation procedure.

7.3.3.3 A report shall be prepared for each batch mixed, indicating

- a) the starting temperature,
- b) the mixing time,
- c) the rotor speed,
- d) the ram pressure,
- e) the temperature of the mix at discharge,
- f) the mixing technique — order of adding ingredients, times, etc.,
- g) the type of mixer used — size, rotor type, etc.,
- h) any allowable mass loss outside the limits given in 7.3.3.1, with the reason for acceptance,
- i) the temperature used for conditioning the carbon black, and
- j) the number of the International Standard specifying the evaluation procedure in which the test mix is to be used.

8 Preparation of standard vulcanized sheets for dumb-bell test pieces

8.1 Conditioning of batches and blank preparation

8.1.1 Batches shall be conditioned for between 2 h and 24 h at one of the standard laboratory temperatures specified in ISO 23529, preferably in a closed container to prevent absorption of moisture from the air or in a room in which the relative humidity is controlled at less than 50 %.

8.1.2 The sheeted batch shall be placed on a flat, clean, dry, metal surface, and the blanks shall be cut to the corresponding dimensions of the mould cavity. The direction of the grain of the rubber shall be marked on each piece. The blanks shall be within +3 g to 0 g of the mass given in Table 2 when they are vulcanized in the mould specified in 8.2.2.

Remilling shall be avoided if possible. Where remilling is necessary, the procedure given in 7.3.2.6 shall be used.

Table 2 — Mass of blank

Density Mg/m ³	Mass g
0,94	47
0,96	48
0,98	49

Table 2 (continued)

Density Mg/m ³	Mass g
1,00	50
1,02	51
1,04	52
1,06	53
1,08	54
1,10	55
1,12	56
1,14	57
1,16	58
1,18	59
1,20	60
1,22	61
1,24	62
1,26	63
1,28	64
1,30	65

8.2 Vulcanization equipment

8.2.1 Press

The press shall be capable of exerting a pressure of not less than 3,5 MPa on the cavity areas of the mould during the entire period of vulcanization. It shall have heated platens of sufficient size that no portion of the rubber is nearer than 30 mm to the edge of the platen during vulcanization. The platens should preferably be made of rolled steel, machined for electric, steam, or thermofluid heating.

When steam heating is used, each platen shall be individually supplied. A self-bleeding trap or small vent shall be placed in the exit steam line to allow steam to flow continuously through the platens. If chamber-type platens are used, the steam outlet shall be placed slightly below the steam chamber, so that good drainage is ensured.

Conduction of heat from the hot platens to the press cross-head shall be reduced as much as practicable by means of a steel grid between them or by other means. Platens shall be suitably shielded from draughts.

The pressing surfaces of the platens shall be plane parallel to within 0,25 mm/m when the platens are at 150 °C and closed under full pressure with a grid of soft solder or lead between them.

With either type of platen, the temperature over the mould area shall be uniform. The maximum deviation from the temperature at the centre of the platen shall not exceed $\pm 0,5$ °C. Between adjacent platens, the temperature difference between corresponding points on the two platens shall not exceed 1 °C and the mean difference in platen temperatures shall not exceed 0,5 °C.

Dimensions in millimetres

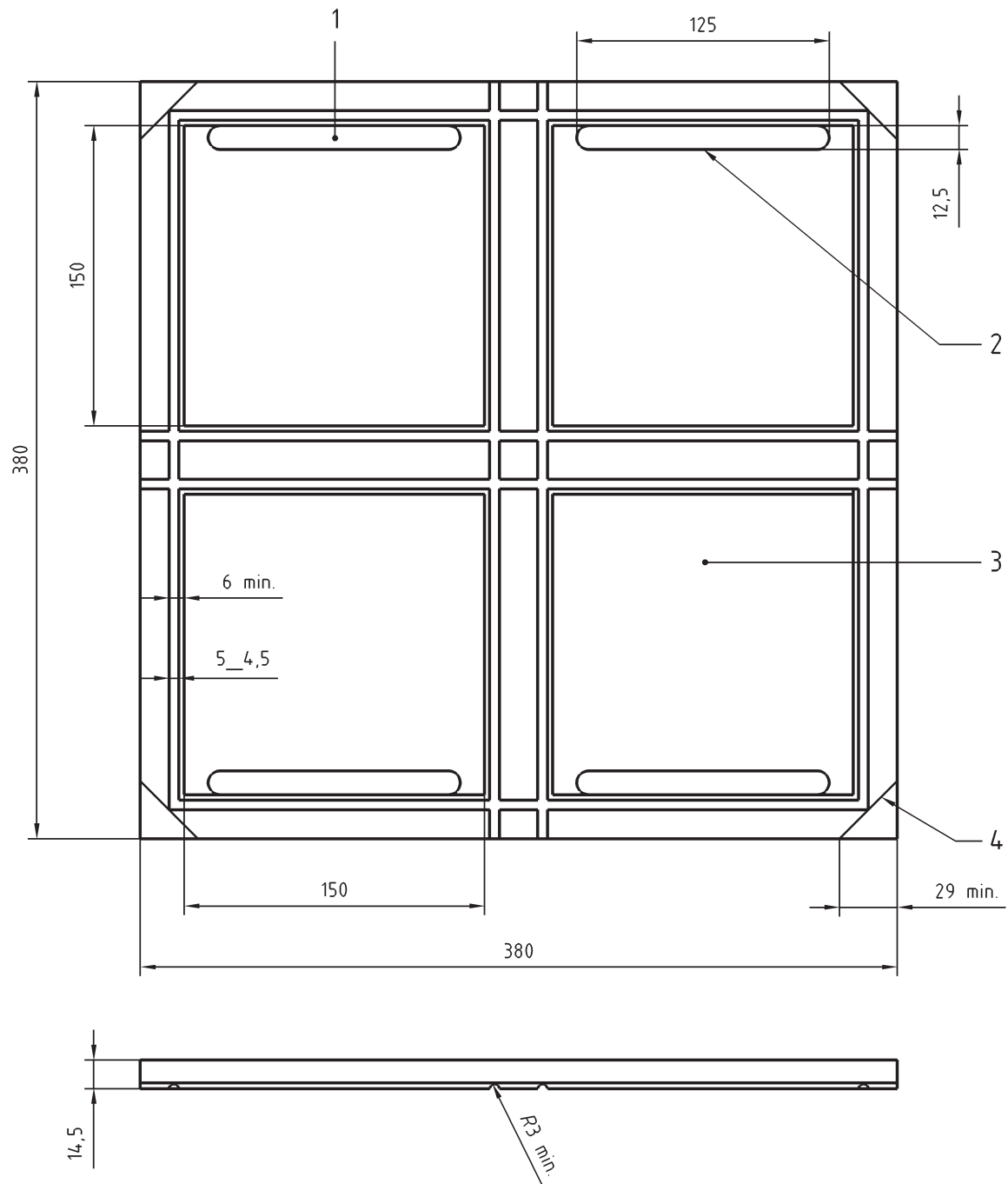

Key

- 1 recess for identification tag
- 2 mill 0,5 mm deep below depth of cavity
- 3 cavities to be 1,9 mm to 2 mm deep
- 4 mill four corners about 3 mm deep for prizing mould apart

NOTE The recesses for identification tags are optional.

Figure 1 — Design for four-cavity mould

8.2.2 Mould

The mould shall have cavity sections of sufficient size to allow the required number of dumb-bells, as specified in ISO 37, to be cut from the vulcanized sheet. A suitable four-cavity mould is shown in [Figure 1](#), with dimensions 150 mm × 150 mm × 2 mm. Alternatively, a mould with rectangular cavities of approximate dimensions 150 mm × 145 mm × 2 mm may be used. This mould enables the milled sheet to be positioned unequivocally with respect to the direction of the grain.

The cavities shall be between 1,9 mm and 2,0 mm deep to within 6 mm of the edges. The corners of the cavities may be rounded with a radius not greater than 6 mm.

The moulding surfaces shall be clean and highly polished. Moulds constructed of hardened steel are preferred, but chromium-plated mild steel and stainless steel are also acceptable. The cover of the mould shall be a flat plate at least 10 mm in thickness and preferably hinged to the cavity section to minimize scratching of the mould surfaces.

Instead of a separate mould and cover, the cavities may be cut directly into the platen of the press.

Normally, a mould release agent shall not be used on the mould surfaces. If a mould release agent is required, however, only a type which does not affect the vulcanized sheet shall be used. The excess shall be removed by vulcanizing and discarding at least one set of sheets. A silicone-type agent or mild soap solution has been found satisfactory, but silicone shall not be used when moulding silicone rubbers.

8.3 Vulcanization procedure

8.3.1 Bring the mould to within $\pm 0,5$ °C of the vulcanization temperature in the closed press and hold at this temperature for at least 20 min before the blanks are inserted. Verify the temperature of the mould by means of a thermocouple or other suitable temperature-measuring device inserted in one of the overflow grooves and in intimate contact with the mould.

8.3.2 Open the press, insert the blanks in the mould, and close the press in the minimum time possible. If necessary, open and close the press a few times to remove trapped air. The time taken for this process shall not be part of the vulcanization time. When the mould is removed from the press to insert the blanks, take any precautions necessary to prevent excessive cooling of the mould by contact with cool metal surfaces or by exposure to air draughts.

8.3.3 The time of vulcanization shall be considered to be the period between the instant the pressure is fully applied and the instant the pressure is released. Hold the mould under a minimum pressure of 3,5 MPa on the cavity areas during vulcanization.

As soon as the press is opened, remove the vulcanized sheets from the mould and cool in water (at room temperature or lower) or on a metal surface (for items used for electrical measurements) for 10 min to 15 min. Then wipe dry the sheets cooled in water and reserve for testing. In both of the preceding operations, take care to prevent undue stretching or deformation.

Alternatively, the moulds may be removed from the press and cooled in water before the vulcanized sheets are removed.

NOTE This alternative procedure may give different results.

8.3.4 Store vulcanizates at one of the standard laboratory temperatures specified in ISO 23529. Separate vulcanizates with aluminium foil or other suitable material to prevent contamination during storage.

8.3.5 For all test purposes, the minimum time between vulcanization and testing shall be 16 h.

8.3.6 The maximum time between vulcanization and testing shall be 96 h and, for evaluations intended to be comparable, the tests shall, as far as possible, be carried out after the same time interval.

Longer periods between vulcanization and testing may be used by agreement between supplier and purchaser.

8.3.7 A report shall be prepared for each batch mixed, indicating

- a) the vulcanization temperature,
- b) the vulcanization time,
- c) the moulding pressure,
- d) the type of mould release agent, if used, and
- e) the number of the International Standard specifying the evaluation procedure in which the test mix is to be used.

9 Preparation of standard vulcanized discs for ring test pieces

9.1 Conditioning of batches and blank preparation

9.1.1 Condition batches as specified in [8.1.1](#).

9.1.2 Place the sheeted batch on a flat, clean, dry, metal surface. Stamp circular blanks 63 mm to 64 mm in diameter from the sheet, so that they fit easily into the cylindrical cavities of the mould shown in [Figure 2](#).

Remilling shall be avoided if possible. Where remilling is necessary, the procedure given in [7.3.2.6](#) shall be used.

9.2 Vulcanization equipment

9.2.1 Press

As specified in [8.2.1](#).

9.2.2 Mould

The mould should have cavity sections similar in dimensions to those shown in [Figure 2](#), which gives discs 65 mm in diameter and 4 mm thick for the preparation of ring test pieces as specified in ISO 37. The mould consists of a lid and a cavity section hinged to each other. The hinges have oblong holes, so as to hold the pressing surfaces in a plane parallel position, thereby preventing distortion of the lid should the press be closed when loaded with thick discs.

The cavity section contains several groups of cylindrical cavities for the moulding of three interconnected discs. Close to each group of cavities is a 10-mm-wide recess which may be used for the identification of individual compounds. For technical reasons, the depth of the recess is less than that of the disc cavities. For identification purposes, an embossed aluminium strip is placed in the recess so that, on moulding, an identity tag is left attached to the group of three discs.

The number of cavities depends on the size of the platens of the curing press available. Hard aluminium alloys have proved to be suitable for the manufacture of the mould shown in [Figure 2](#). Thinner moulds (for example lid 4 mm, cavity [section 8](#) mm) can be made from steel, but hinges required for thinner moulds are more difficult to make.

The cavities shall be uniform in depth to within 0,05 mm. The corners of the cavities may be rounded with a radius not greater than 0,5 mm.

The moulding surface shall be clean and highly polished.

9.3 Vulcanization procedure

As specified in [8.3](#).

10 Precision

See [Annexes A](#) to [C](#).

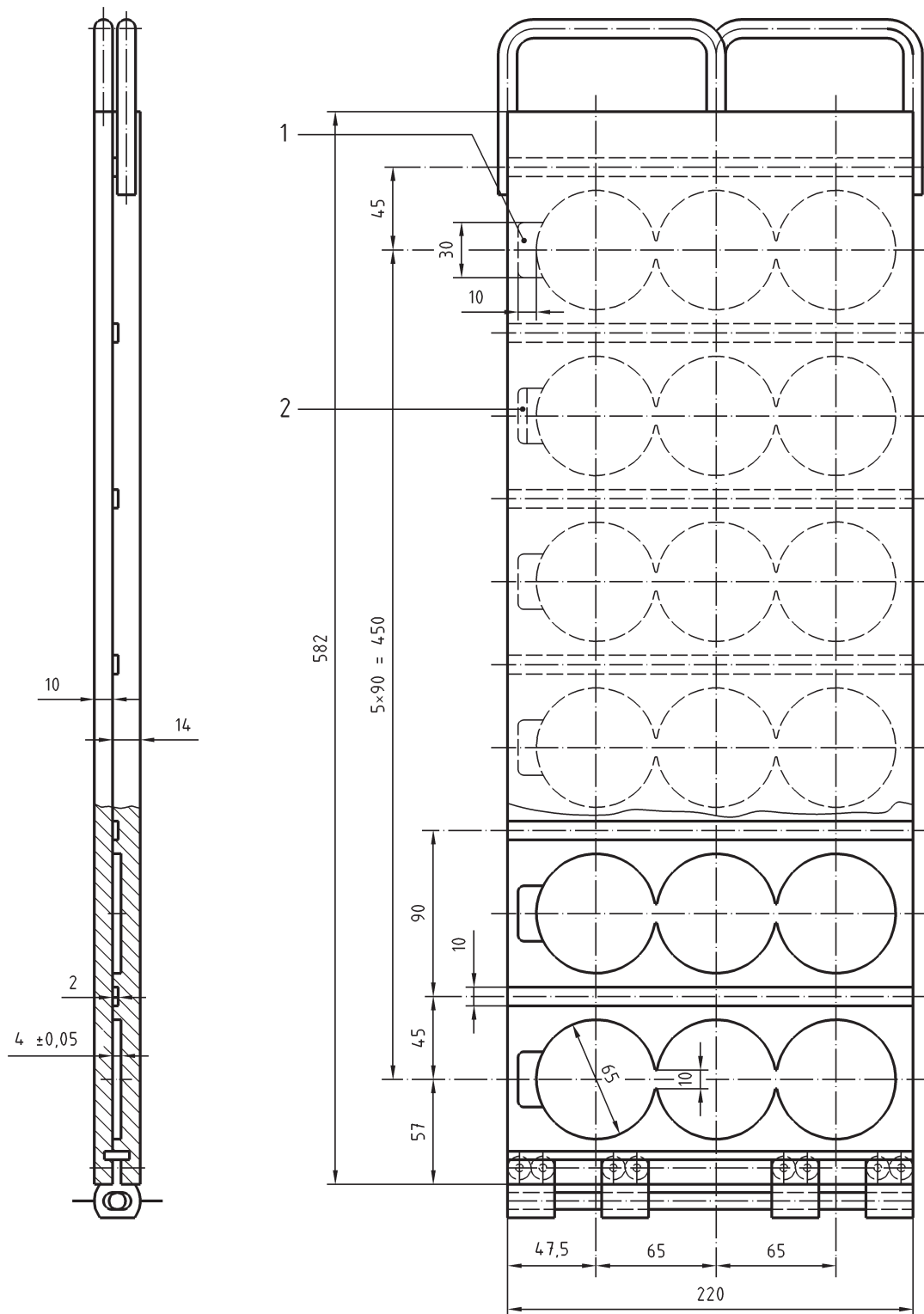

Key

- 1 depth 3,8 mm
- 2 recess for identification tag

NOTE The recesses for identification tags are optional.

Figure 2 — Mould for vulcanizing discs for ring test pieces

Annex A (informative)

Precision statement for both mill and internal mixer

A.1 Background

A.1.1 General

This precision statement was obtained from three interlaboratory test programmes (ITPs) designed to determine the precision of compounds mixed on a laboratory mill and in various sizes of internal mixer. The ITPs were conducted on SBR 1500 (Europrene 1500¹⁾ EST8) in 2003, on BR [Neocis BR40¹⁾, Nd-catalysed, high-cis 1,4-polybutadiene (97 % cis)] in 2004 and on NR (STR 20 CV 60) in 2005, respectively.

The formulations given in the appropriate evaluation standards were used:

- for SBR 1500, ISO 2322, series A;
- for BR, ISO 2476;
- for NR, ISO 1658.

The carbon black used was IRB7.

NOTE The internal mixers used covered those types often described as “miniature”, “intermediate”, and “laboratory”.

All three ITPs were carried out using the precision procedures and guidelines described in ISO/TR 9272:2005. This revised precision International Standard was under ballot review at the time of the first two ITPs. Reference should be made to ISO/TR 9272:2005 for other details and for terminology on precision determination.

Two measurement methods were evaluated for each type of mixing procedure: stress-strain testing (ISO 37) and moving-die curemeter testing (ISO 6502). Stress-strain property precision was evaluated for stress (modulus) at 100 %, 200 %, and 300 % elongation, elongation at break, and tensile strength. Curemeter precision was evaluated for M_H (maximum torque), M_L (minimum torque), t_{s1} (scorch time or time to a 1 dN·m rise), $t'_c(50)$ (time to 50 % of full torque), and $t'_c(90)$ (time to 90 % of full torque). All torques are in dN·m and all times are in minutes. Some limited testing was conducted on compound Mooney viscosity, designated in the results tables as ML(1+4) at 100 °C.

A type 2 precision was evaluated. Each compound was mixed and prepared twice on each of the two test days and tested separately on a day 1/day 2 basis, one week apart.

The test result for each property was taken as the average of the test values obtained on the two mixes prepared on a test day. Precision is given in terms of test results.

A.1.2 Testing in 2003

For the internal mixer testing in 2003, nine laboratories participated in the test programme. However, each laboratory did not have the same type or size of mixer. The sizes of the internal mixers used in the ITP were 80 cm³, 270 cm³, 379 cm³, 588 cm³, 1 580 cm³, and 1 600 cm³.

1) Europrene 1500 and Europrene Neocis BR40 are available from Polimeri Europa S.p.A, Ravenna, Italy. This information is given for the convenience of users of this International Standard and does not constitute an endorsement by ISO of the products produced by this company.

In addition to determining the precision, data analysis for both this 2003 ITP and the 2004 ITP was carried out to determine if, or how, the type of mixer (size and other operating conditions) influenced the test results (see further discussion of this issue in [Annex C](#)). Some laboratories submitted data from more than one size of mixer, and the data from these separate mixers were incorporated into the ITP as data from individual laboratories. This gave a database equivalent to 12 laboratories. Each of the mixer-laboratory combinations was designated as a pseudo-laboratory.

A.1.3 Testing in 2004

For the internal mixer testing in 2004, 10 laboratories participated in the test programme, and again each laboratory did not have the same type of mixer. The sizes of the internal mixers used in the ITP were 75 cm³, 80 cm³, 270 cm³, 379 cm³, 422 cm³, 588 cm³, 1 500 cm³, 1 580 cm³, 1 600 cm³, and 3 322 cm³. Some laboratories submitted data from more than one size of mixer and, as before, the data from these separate mixers were incorporated into the ITP as data from individual laboratories. This gave a database equivalent to 17 laboratories. Each of the mixer-laboratory combinations was again designated as a pseudo-laboratory.

A.1.4 Testing in 2005

For the internal mixer testing in 2005, nine laboratories participated in the test programme, and again each laboratory did not have the same type of internal mixer. The sizes of the internal mixers used in the ITP were 80 cm³, 85 cm³, 242 cm³, 270 cm³, 588 cm³, 1 200 cm³, 1 500 cm³, 1 530 cm³, 1 600 cm³, and 3 000 cm³. Some laboratories submitted data from more than one size of mixer and, as before, the data from these separate mixers were incorporated into the ITP as data from individual laboratories. This gave a database equivalent to 12 laboratories. Each of the mixer-laboratory combinations was again designated as a pseudo-laboratory.

NOTE Two laboratories used FEF black instead of IRB7 and one used the oscillating-disc curemeter instead of the moving-die curemeter. The results from these laboratories were not included in the analysis.

The precision results as determined by these ITPs may not be applied to acceptance or rejection testing for any group of materials or products without documentation that the results of this precision determination actually apply to the products or materials tested.

A.2 Precision results

A.2.1 General

The precision results for all three rubbers (i.e. the compounds prepared from SBR, BR, and NR) for mill mixing for both stress-strain and curemeter testing are given in [Tables A.1](#) and [A.2](#). The precision results for all three rubbers for internal mixer mixing for both stress-strain and curemeter testing are given in [Tables A.3](#) and [A.4](#). These results were obtained for precision analysis using the procedures in ISO/TR 9272:2005 that include the outlier deletion operations as described in ISO/TR 9272:2005. General statements for the use of the precision results are given below. These are given in terms of both the absolute precision, r and R , and also for relative precision, (r) and (R) (see additional discussion in [A.4](#)).

The definition of a test result given in [A.1.1](#) above should be borne in mind when reviewing the precision results and/or in doing any precision check measurements within a laboratory.

A.2.2 Repeatability

The repeatability, or local-domain precision, for each of the test methods has been established as the values given in [Tables A.1](#), [A.2](#), [A.3](#), and [A.4](#) for each measurement parameter listed in the tables. Two individual test results obtained in the same laboratory (by the proper use of this International Standard) that differ by more than the tabulated values for r , in measurement units, or (r) , in percent, should be considered as suspect, i.e. to have come from different populations, and should suggest that some appropriate investigative action be taken.

A.2.3 Reproducibility

The reproducibility, or global-domain precision, for each of these test methods has been established as the values found in [Tables A.1, A.2, A.3, and A.4](#) for each measurement parameter listed in the tables. Two individual test results obtained in different laboratories (by the proper use of this International Standard) that differ by more than the tabulated values for R , in measurement units, or (R) , in percent, should be considered as suspect, i.e. to have come from different populations, and should suggest that some appropriate investigative action be taken.

A.3 Mixer conditions

[Tables B.1, B.2, and B.3](#) give the mixer conditions for each mixer in the three ITPs, i.e. head temperature, rotor speed, rotor type, etc.

A.4 Comparison of relative precision

As a general point, comparisons of (r) and (R) are the only valid type of comparison because of the differences in absolute property values.

The precision results for mill mixing can be summarized as follows. For stress-strain testing (see [Table A.1](#)), the values for repeatability (r) for all three rubbers are reasonably consistent within each stress-strain property, with the possible exception of S_{100} for BR. On an overall basis (all stress-strain tests and all three rubbers), an average (r) of 7,2 % is found. For reproducibility (R) within each stress-strain test property, fairly consistent values are found for each rubber. On an overall basis (all stress-strain tests and all three rubbers), an average (R) of 20,6 % is found. The small numerical differences which can be noted for (r) or (R) are typical (not really significant) for comparisons of this type, given the inherent variations in the results of ITP testing.

For curemeter testing (see [Table A.2](#)), the values for repeatability (r) for all three rubbers are reasonably consistent within each curemeter property, with the possible exception of M_L for SBR and $t'_c(50)$ for NR. On an overall basis (all curemeter tests and all three rubbers), an average (r) of 7,3 % is found. For reproducibility (R) within each curemeter test property, less consistent values are found among the rubbers. On an overall basis (all curemeter tests and all three rubbers), an average (R) of 25,5 % is found.

The differences in the overall average values of (r) and (R) for stress-strain versus curemeter testing are considered to be within the expected variation for such testing.

For internal mixer mixing, the precision results can be summarized as follows. For stress-strain testing (see [Table A.3](#)), the values for repeatability (r) for all three rubbers are reasonably consistent within each stress-strain property, with the possible exception of tensile strength for NR. On an overall basis (all stress-strain tests and all three rubbers), an average (r) of 7,9 % is found. For reproducibility (R) within each stress-strain test property, fairly consistent values are found across the three rubbers. On an overall basis (all stress-strain tests and all three rubbers), an average (R) of 20,6 % is found.

For curemeter testing (see [Table A.4](#)), the values for repeatability (r) for all three rubbers are reasonably consistent within each curemeter property. On an overall basis (all curemeter tests and all three rubbers), an average (r) of 5,5 % is found. For reproducibility (R) within each curemeter test property, reasonably consistent values are found among the rubbers, with the possible exception of M_L for BR. On an overall basis (all curemeter tests and all three rubbers), an average (R) of 32,2 % is found.

For stress-strain properties, mill versus internal mixer, the overall mean (R) values are identical, 20,6 %. For curemeter properties, mill versus internal mixer, the overall mean (R) values are 25,5 % and 32,2 %, respectively, the higher internal mixer value being no doubt due to the added variance component attributable to differences between the internal mixers used in the various laboratories.

A.5 Bias

Bias is the difference between a measured average test result and a reference or true value for the measurement in question. Reference values do not exist for this test method and therefore bias cannot be determined.

Table A.1 — Precision (type 2) for SBR, BR and NR — Mill mixing — Stress-strain properties

Parameter measured	Material	Mean	Within-laboratory			Between laboratories			Number of laboratories ^a
			s_r	r	(r)	s_R	R	(R)	
S_{100} MPa	SBR	3,0	0,68	0,19	6,35	0,178	0,5	16,5	4
	BR	2,2	0,094	0,26	12,2	0,10	0,28	13,0	6
	NR	2,7	0,029	0,08	3,0	0,092	0,26	9,7	5
S_{200} MPa	SBR	9,0	0,22	0,63	6,94	0,64	1,79	19,8	4
	BR	5,4	0,13	0,37	6,9	0,42	1,19	21,9	6
	NR	7,1	0,12	0,33	4,6	0,4	1,13	15,8	5
S_{300} MPa	SBR	16,7	0,49	1,38	8,3	1,20	3,36	20,2	6
	BR	10,8	0,14	0,38	3,5	1,02	2,86	26,4	6
	NR	13,5	0,16	0,45	3,3	0,93	2,60	19,3	5
E_b %	SBR	492	16,7	46,7	9,5	20,8	58,3	11,9	7
	BR	417	11,4	31,9	7,7	30,2	84,5	20,3	8
	NR	527	11,2	31,5	20,2	38,0	106	20,2	6
TS_b MPa	SBR	27,5	0,60	1,68	6,1	2,62	7,35	26,7	8
	BR	17,4	0,34	0,96	5,5	2,14	5,98	34,4	7
	NR	28,7	0,39	1,09	3,8	3,31	9,3	32,3	6
Average					7,19			20,56	

s_r is the within-laboratory standard deviation (in measurement units).

r is the repeatability (in measurement units).

(r) is the repeatability (in percent of mean level).

s_R is the between-laboratory standard deviation (for total between-laboratory variation in measurement units).

R is the reproducibility (in measurement units).

(R) is the reproducibility (in percent of mean level).

^a Final number of laboratories remaining in the ITP after deletion of outliers (using option 1).

Table A.2 — Precision (type 2) for SBR, BR and NR — Mill mixing — Curemeter properties

Parameter measured	Material	Mean	Within-laboratory			Between laboratories			Number of laboratories ^a
			s_r	r	(r)	s_R	R	(R)	
M_H dN·m	SBR	19,1	0,33	0,92	4,8	2,65	7,41	38,7	9
	BR	18,3	0,29	0,82	4,5	0,94	2,62	14,3	5
	NR	14,7	0,22	0,62	42,0	1,96	5,50	37,3	4
M_L dN·m	SBR	2,64	0,06	0,16	6,1	0,16	0,44	16,8	7
	BR	2,83	0,13	0,35	12,4	0,23	0,64	22,5	7
	NR	1,62	0,09	0,25	15,4	0,29	0,82	50,6	5
t_{s1} min	SBR	2,44	0,09	0,26	10,5	0,19	0,54	22,1	8
	BR	2,87	0,14	0,38	13,2	0,20	0,55	19,1	6
	NR	1,58	0,04	0,12	7,6	0,39	1,09	69,1	5
$t'_c(50)$ min	SBR	7,02	0,07	0,19	2,7	0,33	0,92	13,1	7
	BR	6,91	0,13	0,36	5,3	0,29	0,82	11,9	5
	NR	3,17	0,12	0,34	10,6	0,27	0,75	23,5	6
$t'_c(90)$ min	SBR	13,4	0,11	0,31	2,3	0,52	1,47	10,9	6
	BR	11,1	0,15	0,43	3,9	0,90	2,53	22,8	5
	NR	5,4	0,12	0,34	6,3	0,19	0,53	9,9	5
Average					7,32			25,51	
Compound viscosity $M_L(1+4)$ at 100 °C	SBR	NA	NA	NA	NA	NA	NA	NA	
	BR	68,4	0,73	2,04	3,0	7,87	22,0	32,2	6
	NR	51,8	2,35	6,57	12,7	3,85	10,8	20,8	5

s_r is the within-laboratory standard deviation (in measurement units).
 r is the repeatability (in measurement units).
(r) is the repeatability (in percent of mean level).
 s_R is the between-laboratory standard deviation (for total between-laboratory variation in measurement units).
 R is the reproducibility (in measurement units).
(R) is the reproducibility (in percent of mean level).
NA not available.
^a Final number of laboratories remaining in the ITP after deletion of outliers (using option 1).

Table A.3 — Precision (type 2) for SBR, BR and NR — Internal mixer — Stress-strain properties

Parameter measured	Material	Mean	Within-laboratory			Between laboratories			Number of laboratories ^{a,b}
			s_r	r	(r)	s_R	R	(R)	
S_{100} MPa	SBR	3,06	0,08	0,22	7,2	0,14	0,40	13,1	7
	BR	2,33	0,09	0,24	10,3	0,20	0,57	24,4	12
	NR	2,55	0,05	0,13	5,1	0,23	0,64	25,2	8
S_{200} MPa	SBR	9,12	0,22	0,62	6,8	0,44	1,24	13,5	7
	BR	5,82	0,21	0,59	10,1	0,47	1,31	22,6	12
	NR	6,69	0,15	0,43	6,4	0,61	1,70	25,4	8
S_{300} MPa	SBR	16,7	0,44	1,24	7,3	0,84	2,36	13,9	10
	BR	11,1	0,35	0,97	8,8	0,84	2,35	21,2	13
	NR	13,0	0,20	0,56	4,3	0,83	2,33	18,0	8
E_b %	SBR	456	19,3	53,9	11,8	46,9	131,5	28,8	11
	BR	415	12,0	33,7	8,1	40,6	114,0	27,4	15
	NR	518	7,10	19,9	3,8	19,6	54,9	10,6	6
TS_b MPa	SBR	27,5	1,04	2,90	10,6	1,99	5,58	20,3	11
	BR	17,0	0,84	2,34	13,8	1,17	3,28	19,3	15
	NR	29,2	0,44	1,24	4,2	2,66	7,46	25,5	8
Average					7,91			20,61	

s_r is the within-laboratory standard deviation (in measurement units).

r is the repeatability (in measurement units).

(r) is the repeatability (in percent of mean level).

s_R is the between-laboratory standard deviation (for total between-laboratory variation in measurement units).

R is the reproducibility (in measurement units).

(R) is the reproducibility (in percent of mean level).

^a Final number of laboratories remaining in the ITP after deletion of outliers (using option 1).

^b For internal mixer tests, the number of laboratories includes the pseudo-laboratories.

Table A.4 — Precision (type 2) for SBR, BR and NR — Internal mixer — Curemeter properties

Parameter measured	Material	Mean	Within-laboratory			Between laboratories			Number of laboratories ^{a,b}
			s_r	r	(r)	s_R	R	(R)	
M_H dN·m	SBR	20,3	0,16	0,45	2,2	2,21	6,19	30,5	10
	BR	18,6	0,20	0,55	3,0	1,05	2,94	15,9	10
	NR	14,9	0,15	0,41	2,8	0,81	2,26	15,2	7
M_L dN·m	SBR	2,73	0,07	0,18	6,7	0,24	0,67	24,6	11
	BR	2,97	0,05	0,15	5,0	0,67	1,86	62,6	13
	NR	1,94	0,06	0,17	8,8	0,18	0,49	25,2	8
t_{s1} min	SBR	1,71	0,06	0,17	10,0	0,33	0,93	54,8	10
	BR	2,84	0,06	0,19	6,5	0,59	1,64	57,9	13
	NR	1,57	0,04	0,12	7,4	0,33	0,91	58,2	9
$t'_c(50)$ min	SBR	6,16	0,15	0,42	6,8	0,35	0,99	16,0	9
	BR	6,63	0,09	0,24	3,7	0,66	1,85	27,9	12
	NR	3,00	0,06	0,17	5,7	0,34	0,95	31,7	7
$t'_c(90)$ min	SBR	13,5	0,23	0,64	4,7	0,84	2,35	17,5	10
	BR	10,5	0,18	0,50	4,7	1,05	2,94	28,1	14
	NR	5,41	0,09	0,26	4,9	0,33	0,93	17,3	6
Average					5,53			32,23	
Compound viscosity $M_{L(1+4)}$ at 100 °C	SBR	NA	NA	NA	NA	NA	NA	NA	
	BR	NA	NA	NA	NA	NA	NA	NA	
	NR	55,8	1,42	3,97	7,1	2,19	6,12	11,0	8

s_r is the within-laboratory standard deviation (in measurement units).

r is the repeatability (in measurement units).

(r) is the repeatability (in percent of mean level).

s_R is the between-laboratory standard deviation (for total between-laboratory variation in measurement units).

R is the reproducibility (in measurement units).

(R) is the reproducibility (in percent of mean level).

NA not available.

^a Final number of laboratories remaining in the ITP after deletion of outliers (using option 1).

^b For internal mixer tests, the number of laboratories includes the pseudo-laboratories.

Annex B (informative)

Internal mixer parameters and operating conditions for the three interlaboratory test programmes

This annex gives the operating conditions for the internal mixers used for each of the three ITPs, i.e. for SBR, BR, and NR (see Tables B.1, B.2, and B.3). Each column gives the values for head temperature, rotor speed, rotor type, etc., for an individual mixer in that ITP.

NOTE 1 The batch factor is the batch volume expressed as a proportion of the formulation volume.

NOTE 2 The loading is the factor used to obtain the nominal mixer capacity from the total free volume (see 3.3 and 3.4).

Table B.1 — Brief details of the mixer conditions used in the SBR 1500 ITP

Head temperature, °C	50	70					
Rotor speed, r/min	60	60					
Rotor type	Cam	Banbury					
Free volume, cm ³	80	80					
Batch factor	0,42	0,41					
Loading, %	72	70					
Cycle, min	5	7					
Head temperature, °C	60	60	60	60	60	60	60
Rotor speed, r/min	60	60	60	60	60	60	60
Rotor type	Banbury	Banbury	Banbury	Banbury	Banbury	Banbury	Banbury
Free volume, cm ³	270	270	379	379	379	588	588
Batch factor	1	1	1,6	1,6	1,6	2,48	2,48
Loading, %	53	53	60	60	60	60	60
Cycle, min	9	9	9	9	9	9	9
Head temperature, °C	50	40	40				
Rotor speed, r/min	77	30	30				
Rotor type	Banbury	Banbury	Banbury				
Free volume, cm ³	1 500	1 580	1 600				
Batch factor	8,43	6,1	7,85				
Loading, %	80	55	70				
Cycle, min	8	7	7				

Table B.2 — Brief details of the mixing conditions used in the BR ITP

Head temperature, °C	50	40	60	88			
Rotor speed, r/min	60	120/80	60	60			
Rotor type	Cam	Banbury	4 wings	Banbury			
Free volume, cm ³	75	80	80	75			
Loading, %	76,7	70	81	75			
Cycle, min	5	6 + 3	9	12			
Head temperature, °C	60	60	60	60	60	60	
Rotor speed, r/min	60	60	60	60	60	60	
Rotor type	Banbury	Banbury	Banbury	Banbury	6 wings	Banbury	
Free volume, cm ³	270	379	379	379	422	588	
Loading, %	60	60	60	60	60	60	
Cycle, min	9	9	9	9	9	9	
Head temperature, °C	60	90	90	50	40	40	50
Rotor speed, r/min	60	75	75	77	70 / 40	90 / 40	50
Rotor type	Banbury	2 wings	2 wings	Banbury	Banbury	Banbury	4 wings
Free volume, cm ³	1 200	1 500	1 500	1 500	1 580	1 600	3 322
Loading, %	70	80	80	77	55	70	72
Cycle, min	6 + 3	6 + 3	6 + 3	6 + 3	6 + 3	6 + 3	6 + 3

Table B.3 — Brief details of the mixing conditions used in the NR (2005) ITP

Head temperature, °C	70	50	70	70			
Rotor speed, r/min	77	60	30	60			
Rotor type	2 wings	Cam	Banbury	Banbury			
Free volume, cm ³	1 530	85	3 000	588			
Loading, %	75	75	80	60			
Cycle	1 stage	1 stage	1 stage	1 stage			
Head temperature, °C	70	70	70	70	70	75	
Rotor speed, r/min	60	60	77	100	60+30	30	
Rotor type	Banbury	Banbury	Banbury	2 wings	2 wings	4 wings	
Free volume, cm ³	588	270	1 200	2 145	1 500	80	
Loading, %	60	60	70	70	83	94	
Cycle	1 stage	1 stage	2 stages	1 stage	2 stages	1 stage	

Annex C (informative)

Further analysis of the ITP data

The data from all three ITPs are considered to be consistent and reliable. The precision parameters so obtained are intermediate in quality level. Higher quality would correspond to lower r and R values or better precision. However, since the ITP database was generated for a broad range of mixer capacities and other operating variables in the various laboratories, additional analysis of the data has resulted in a controversy over the reported effect of some mixer variables on some measured properties.

Analysis of the 2003 and 2004 ITPs using a multiple-regression (MR) technique based on the usual replicate data indicates that a dependency does exist for some variables for certain properties, while the results of a factor analysis were reported as indicating no pronounced dependence on mixer variables.

The MR analysis indicates that certain mixer operating variables, e.g. head temperature, mixer volume, rotor speed, nominal mixer capacity (% loading) and cycle time, have an influence on some of the measured properties – mainly the time parameters of curemeter testing, i.e. t_{s1} , $t'_c(50)$, $t'_c(90)$.

Correction for those mixer variables that were declared as significant at the $P = 0,05$ level for the MR analysis yields lower reproducibility precision values, i.e. better precision, especially for the curemeter time properties, as shown by the reduction factors given in Table C.1. The reduction factor is the value of r or R after correction divided by the original value.

The reduction factors for repeatability are close to 1, but those for reproducibility are, with some minor exceptions, substantially less than 1.

Table C.1 — Reduction factors for r and R after multiple-regression analysis

Parameter measured	Repeatability reduction factor		Reproducibility reduction factor	
	2003	2004	2003	2004
S_{100}	NA	NA	NA	NA
S_{200}	NA	NA	NA	NA
S_{300}	1,00	0,97	1,00	1,36
E_b	1,00	0,88	0,37	0,37
TS_b	1,00	1,01	0,56	0,85
M_H	1,00	0,96	0,80	1,32
M_L	1,00	1,00	0,46	0,57
t_{s1}	1,00	0,96	0,43	0,25
$t'_c(50)$	1,00	1,04	0,97	0,46
$t'_c(90)$	1,00	0,84	0,45	0,64

NA not available.

The most significant operating conditions have been shown to be mixer volume, rotor speed, rotor type, and nominal mixer capacity (% loading).

This additional precision analysis with corrected data may be regarded as a refinement of already adequate precision data.

Bibliography

- [1] ISO 2322, *Styrene-butadiene rubber (SBR) — Emulsion- and solution-polymerized types — Evaluation procedures*
- [2] ISO 1658, *Natural rubber (NR) — Evaluation procedure*
- [3] ISO 2476, *Butadiene rubber (BR) — Solution-polymerized types — Evaluation procedures*
- [4] ISO 6502, *Rubber — Guide to the use of curemeters*
- [5] ISO/TR 9272:2005, *Rubber and rubber products — Determination of precision for test method standards*

British Standards Institution (BSI)

BSI is the national body responsible for preparing British Standards and other standards-related publications, information and services.

BSI is incorporated by Royal Charter. British Standards and other standardization products are published by BSI Standards Limited.

About us

We bring together business, industry, government, consumers, innovators and others to shape their combined experience and expertise into standards-based solutions.

The knowledge embodied in our standards has been carefully assembled in a dependable format and refined through our open consultation process. Organizations of all sizes and across all sectors choose standards to help them achieve their goals.

Information on standards

We can provide you with the knowledge that your organization needs to succeed. Find out more about British Standards by visiting our website at bsigroup.com/standards or contacting our Customer Services team or Knowledge Centre.

Buying standards

You can buy and download PDF versions of BSI publications, including British and adopted European and international standards, through our website at bsigroup.com/shop, where hard copies can also be purchased.

If you need international and foreign standards from other Standards Development Organizations, hard copies can be ordered from our Customer Services team.

Subscriptions

Our range of subscription services are designed to make using standards easier for you. For further information on our subscription products go to bsigroup.com/subscriptions.

With **British Standards Online (BSOL)** you'll have instant access to over 55,000 British and adopted European and international standards from your desktop. It's available 24/7 and is refreshed daily so you'll always be up to date.

You can keep in touch with standards developments and receive substantial discounts on the purchase price of standards, both in single copy and subscription format, by becoming a **BSI Subscribing Member**.

PLUS is an updating service exclusive to BSI Subscribing Members. You will automatically receive the latest hard copy of your standards when they're revised or replaced.

To find out more about becoming a BSI Subscribing Member and the benefits of membership, please visit bsigroup.com/shop.

With a **Multi-User Network Licence (MUNL)** you are able to host standards publications on your intranet. Licences can cover as few or as many users as you wish. With updates supplied as soon as they're available, you can be sure your documentation is current. For further information, email bsmusales@bsigroup.com.

BSI Group Headquarters

389 Chiswick High Road London W4 4AL UK

Revisions

Our British Standards and other publications are updated by amendment or revision.

We continually improve the quality of our products and services to benefit your business. If you find an inaccuracy or ambiguity within a British Standard or other BSI publication please inform the Knowledge Centre.

Copyright

All the data, software and documentation set out in all British Standards and other BSI publications are the property of and copyrighted by BSI, or some person or entity that owns copyright in the information used (such as the international standardization bodies) and has formally licensed such information to BSI for commercial publication and use. Except as permitted under the Copyright, Designs and Patents Act 1988 no extract may be reproduced, stored in a retrieval system or transmitted in any form or by any means – electronic, photocopying, recording or otherwise – without prior written permission from BSI. Details and advice can be obtained from the Copyright & Licensing Department.

Useful Contacts:

Customer Services

Tel: +44 845 086 9001

Email (orders): orders@bsigroup.com

Email (enquiries): cservices@bsigroup.com

Subscriptions

Tel: +44 845 086 9001

Email: subscriptions@bsigroup.com

Knowledge Centre

Tel: +44 20 8996 7004

Email: knowledgecentre@bsigroup.com

Copyright & Licensing

Tel: +44 20 8996 7070

Email: copyright@bsigroup.com



...making excellence a habit.™