

Testing of concrete

Part 8: Determination of drying shrinkage of concrete for samples prepared in the field or in the laboratory

ICS 91.100.30

National foreword

This British Standard is the UK implementation of ISO 1920-8:2009.

The UK participation in its preparation was entrusted to Technical Committee B/517/1, Concrete production and testing.

A list of organizations represented on this committee can be obtained on request to its secretary.

This publication does not purport to include all the necessary provisions of a contract. Users are responsible for its correct application.

Compliance with a British Standard cannot confer immunity from legal obligations.

This British Standard was published under the authority of the Standards Policy and Strategy Committee on 30 November 2009
© BSI 2009

Amendments/corrigenda issued since publication

Date	Comments

ISBN 978 0 580 59476 2

INTERNATIONAL STANDARD

ISO
1920-8

First edition
2009-04-01

Testing of concrete —

Part 8:

Determination of drying shrinkage of concrete for samples prepared in the field or in the laboratory

Essais du béton —

*Partie 8: Détermination du retrait de séchage du béton d'échantillons
préparés sur le terrain ou en laboratoire*



Reference number
ISO 1920-8:2009(E)

PDF disclaimer

This PDF file may contain embedded typefaces. In accordance with Adobe's licensing policy, this file may be printed or viewed but shall not be edited unless the typefaces which are embedded are licensed to and installed on the computer performing the editing. In downloading this file, parties accept therein the responsibility of not infringing Adobe's licensing policy. The ISO Central Secretariat accepts no liability in this area.

Adobe is a trademark of Adobe Systems Incorporated.

Details of the software products used to create this PDF file can be found in the General Info relative to the file; the PDF-creation parameters were optimized for printing. Every care has been taken to ensure that the file is suitable for use by ISO member bodies. In the unlikely event that a problem relating to it is found, please inform the Central Secretariat at the address given below.



COPYRIGHT PROTECTED DOCUMENT

© ISO 2009

All rights reserved. Unless otherwise specified, no part of this publication may be reproduced or utilized in any form or by any means, electronic or mechanical, including photocopying and microfilm, without permission in writing from either ISO at the address below or ISO's member body in the country of the requester.

ISO copyright office
Case postale 56 • CH-1211 Geneva 20
Tel. + 41 22 749 01 11
Fax + 41 22 749 09 47
E-mail copyright@iso.org
Web www.iso.org

Published in Switzerland

Contents		Page
Foreword		iv
1	Scope	1
2	Normative references	1
3	Terms and definitions	1
4	Principle	2
5	Apparatus	2
6	Test samples and specimens	7
6.1	Sampling	7
6.2	Test specimens	8
7	Procedure	8
7.1	Measurement of consistence and temperature of concrete	8
7.2	Preparation and filling of the moulds	8
7.3	Compacting of concrete	8
7.4	Curing of specimens	9
7.5	Drying and measurement of specimens	10
8	Calculation and expression of results	12
9	Test report	12
10	Precision for laboratory-prepared specimens	14
Annex A (informative) A suitable horizontal length comparator		15

Foreword

ISO (the International Organization for Standardization) is a worldwide federation of national standards bodies (ISO member bodies). The work of preparing International Standards is normally carried out through ISO technical committees. Each member body interested in a subject for which a technical committee has been established has the right to be represented on that committee. International organizations, governmental and non-governmental, in liaison with ISO, also take part in the work. ISO collaborates closely with the International Electrotechnical Commission (IEC) on all matters of electrotechnical standardization.

International Standards are drafted in accordance with the rules given in the ISO/IEC Directives, Part 2.

The main task of technical committees is to prepare International Standards. Draft International Standards adopted by the technical committees are circulated to the member bodies for voting. Publication as an International Standard requires approval by at least 75 % of the member bodies casting a vote.

Attention is drawn to the possibility that some of the elements of this document may be the subject of patent rights. ISO shall not be held responsible for identifying any or all such patent rights.

ISO 1920-8 was prepared by Technical Committee ISO/TC 71, *Concrete, reinforced concrete and pre-stressed concrete*, Subcommittee SC 1, *Test methods for concrete*.

ISO 1920 consists of the following parts, under the general title *Testing of concrete*:

- *Part 1: Sampling of fresh concrete*
- *Part 2: Properties of fresh concrete*
- *Part 3: Making and curing test specimens*
- *Part 4: Strength of hardened concrete*
- *Part 5: Properties of hardened concrete other than strength*
- *Part 6: Sampling, preparing and testing of concrete cores*
- *Part 7: Non-destructive tests on hardened concrete*
- *Part 8: Determination of drying shrinkage of concrete for samples prepared in the field or in the laboratory*
- *Part 9: Determination of creep of concrete cylinders in compression*

The following part is under preparation:

- *Part 10: Determination of static modulus of elasticity in compression*

Testing of concrete —

Part 8:

Determination of drying shrinkage of concrete for samples prepared in the field or in the laboratory

1 Scope

This part of ISO 1920 specifies a method for determining the length changes of concrete specimens due to drying in air, and the method of preparing and curing the concrete specimens to be tested.

It is applicable for the testing of specimens prepared in the laboratory or in the field, in which the maximum nominal size of aggregate in the concrete, in accordance with ISO 6274, does not exceed 25 mm.

The precision statement in Clause 10 does not apply to specimens that have had non-standard initial curing (normally field-prepared specimens). In addition, this part of ISO 1920 requires that field-prepared specimens be marked, recorded and reported as such.

NOTE 1 This test method is not always suitable for very low slump concrete (less than 20 mm), primarily due to the difficulties in obtaining adequate compaction. Provided adequate compaction is obtained, the method is applicable.

NOTE 2 The method is specifically developed for measurement of drying shrinkage of concrete, but it is capable of adaptation for measurement of length changes of specimens subjected to a variety of environmental conditions.

2 Normative references

The following referenced documents are essential for the application of this part of ISO 1920. For dated references, only the edition cited applies. For undated references, the latest edition of the referenced document (including any amendments) applies.

ISO 1920-1, *Testing of concrete — Part 1: Sampling of fresh concrete*

ISO 1920-2, *Testing of concrete — Part 2: Properties of fresh concrete*

ISO 1920-3:2004, *Testing of concrete — Part 3: Making and curing test specimens*

ISO 6274, *Concrete — Sieve analysis of aggregates*

3 Terms and definitions

For the purposes of this document, the following terms and definitions apply.

3.1

preparing laboratory

laboratory responsible for sampling of concrete, moulding of specimens, initial curing in moulds, demoulding, initial moist curing and transport to measuring laboratory (if required)

3.2 measuring laboratory

laboratory responsible for completion of initial moist curing, storage in drying room and measurement of specimens

NOTE In some instances, the preparing and measuring laboratories will be the same.

4 Principle

Specimens are cured and air dried for a specified time, and the change in length is measured.

5 Apparatus

5.1 Drying room, with suitably controlled temperature, humidity and air circulation, for storing specimens in air and for measuring their length.

The room shall meet the following requirements.

- a) Air shall be circulated through the room in a uniform manner, so that the specified conditions are attained adjacent to all specimens under test.
- b) The temperature in the drying room shall be maintained at (22 ± 2) °C.
- c) The relative humidity in the drying room shall be maintained at (55 ± 5) % at all times.
- d) The room shall be fitted with recording devices, capable of rapid response to changes in room conditions, which will continuously record the temperature and the relative humidity.

The recording detectors shall be verified against a standardized Assmann hygrometer at intervals of time that will assure compliance with the temperature and humidity requirements specified in 5.1, b) and c).

NOTE 1 A suitable rapid response device for recording temperature and humidity uses a combined detector with a thin-film capacitor for humidity and a platinum resistance thermocouple for temperature measurement. Response time for this type of detector is measured in seconds and is virtually instantaneous within the narrow range required for this test method.

NOTE 2 Most thermo hygrographs are unsuitable for the purpose, as the response is too slow to detect the full extent of fluctuations, particularly with the hair type of humidity detector.

- e) The rate of air movement in the drying room shall be determined and controlled by sensors in order to maintain the rate of evaporation at (12 ± 5) ml per 24 h. The evaporation rates shall be determined by measuring the loss in weight of water in 400 ml low-form beakers of internal diameter (78 ± 5) mm, initially containing approximately 375 g of water at a temperature of (20 ± 2) °C. The weight of water in the beaker shall not fall below 325 g. Each beaker shall be placed midway between test specimens on the storage racks with the water level at approximately the same height as the top of the specimens.

Systematic checks shall be carried out on the sensors or on the evaporation rates by varying the location of the beakers within the drying room at least monthly, or where conditions have changed. The results shall be recorded.

- f) The requirements for temperature, humidity and evaporation rate apply to each storage position. Only positions that conform to these requirements shall be used for storage of test specimens.
- g) The drying room shall be fitted with suitable racks for storing specimens. The racks shall permit free circulation of air around specimens, except for necessary supports, and shall be so situated with respect to the nearest wall or other obstruction that air circulation is not restricted in the intervening

space. The horizontal supports shall consist of non-absorptive members having a total bearing width supporting the specimen of not more than 25 mm.

5.2 Moulds, made of non-absorbent material that does not react with cement paste and their internal surfaces; shall have a smooth finish.

The moulds shall be substantial enough to hold their form without distortion and shall be substantially leak proof. They shall meet the following requirements.

5.2.1 General

Each mould shall be provided with a base plate, two end plates and two side plates which are securely fastened to the end plates, and two partially loose end plates which act as gauge stud holders. Each gauge stud holder shall fit inside the end of the mould and shall locate and secure a gauge stud during the setting period of the concrete. Each gauge stud holder shall be held in position against the end plate by a retaining screw and shall be capable of release after compaction of the concrete. The opposite side plates shall be parallel.

The dimensions of the mould shall be one of the following.

- a) For specimens having dimensions of 75 mm × 75 mm × 280 mm (see 6.2.2)
 - the distance between the opposite side plates shall be (75 ± 1) mm, and
 - the inside height shall be (75 ± 1) mm;
- b) For specimens having dimensions of 100 mm × 100 mm × 400 mm
 - the distance between the opposite side plates shall be (100 ± 1) mm, and
 - the inside height shall be (100 ± 1) mm.

5.2.2 Construction of the mould

The mould shall be aligned coaxially along the central axis of the mould.

- a) For specimens having dimensions of 75 mm × 75 mm × 280 mm:
 - the distance between the inner ends of the two studs shall be $(250 \pm 0,5)$ mm;
 - the distance between the outer ends of the gauge studs shall be (295 ± 1) mm;
 - gauge studs shall protrude from the gauge stud holders to a distance of (15 ± 1) mm.
- b) For specimens having dimensions of 100 mm × 100 mm × 400 mm:
 - the distance between the inner ends of the two studs shall be $(360 \pm 0,5)$ mm;
 - the distance between the outer ends of the gauge studs shall be (420 ± 1) mm;
 - gauge studs shall protrude from the gauge stud holders to a distance of (20 ± 1) mm.

A suitable form of construction of the moulds is shown in Figure 1.

5.3 Gauge studs, made of stainless steel and conforming to the dimensions shown in Figure 2.

The radius of the gauge stud end shall be such as to assure compliance to the precision requirements for measuring length changes, as specified in 5.8.1.

Gauge studs for horizontal and vertical comparators shall not be interchanged.

5.4 Length gauge, for checking the nominal length between gauge studs (5.3).

The length gauge shall be made of metal, and the specifications shall be as follows.

- a) For specimens having dimensions of 75 mm × 75 mm × 280 mm
 - the diameter of the length gauge shall be not less than 6 mm, and
 - the length of the length gauge shall be $(250 \pm 0,2)$ mm;
- b) For specimens having dimensions of 100 mm × 100 mm × 400 mm
 - the diameter of the length gauge shall be not less than 10 mm, and
 - the length of the length gauge shall be $(360 \pm 0,2)$ mm.

The ends of the bar shall be flat and perpendicular to its length.

5.5 Means of compaction, consisting of the following.

5.5.1 Tamping bar, compacting bar, straight, made of steel having a rectangular shape of approximately 25 mm × 10 mm, a length of approximately 600 mm and with a ramming face square with the axis.

5.5.2 Tamping rod, compacting rod of circular cross-section, straight, made of steel, having a diameter of approximately 16 mm, a length of approximately 600 mm and with round ends.

5.5.3 External vibrator, table type with provision for clamping of the mould (5.2), capable of compacting concrete in the moulds. Internal vibrators shall not be used.

NOTE A vibrating table with a nominal frequency of vibration of 50 Hz is usually suitable.

5.6 Mallet.

5.7 Balance, used to determine the mass of the concrete specimen and having an accuracy of at least 0,1 g.

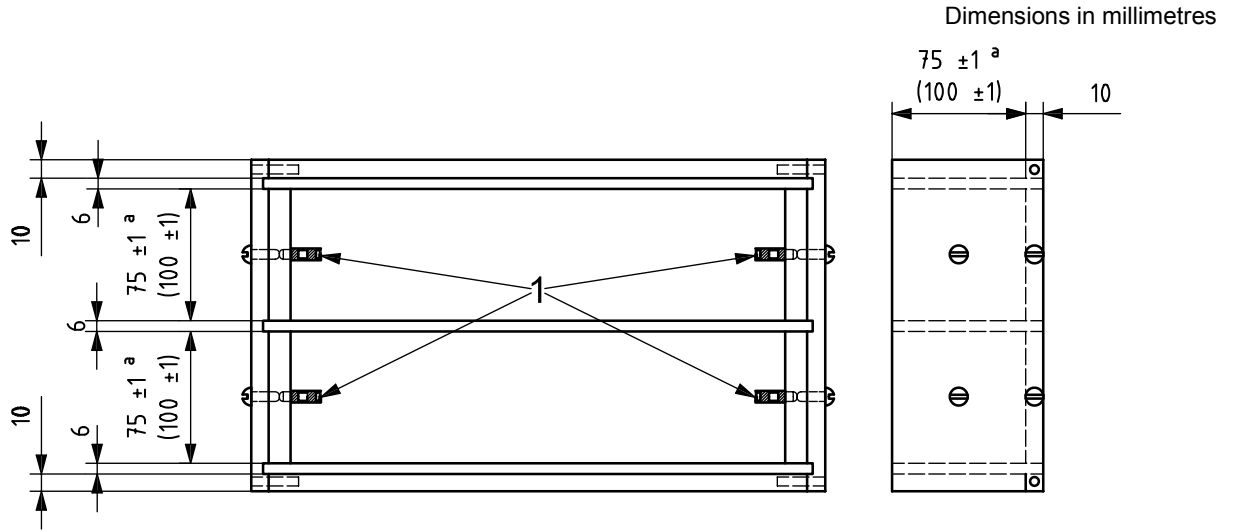

a) Double mould

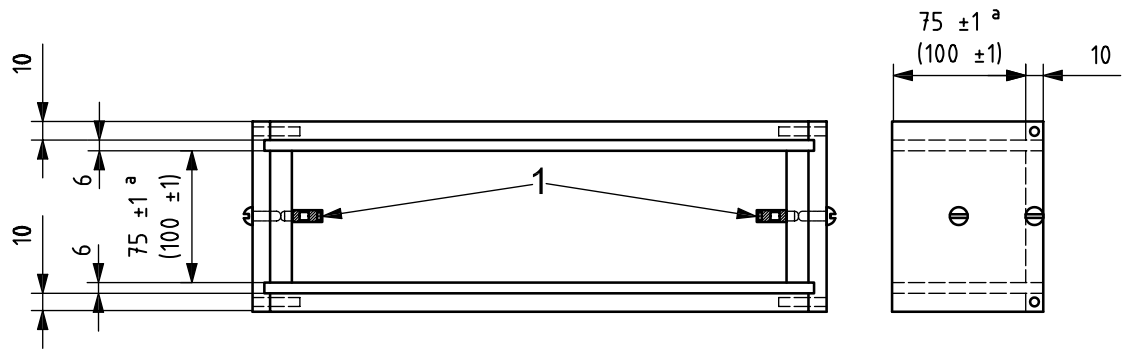

b) Single mould

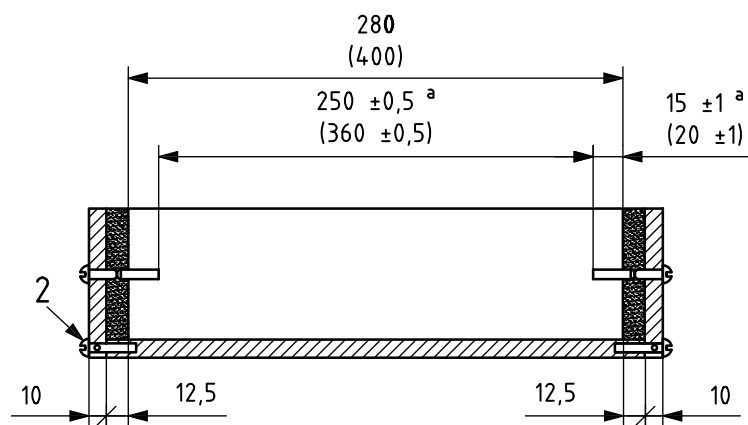

c) Selection of mould

Figure 1 — Details of a typical mould (continued)

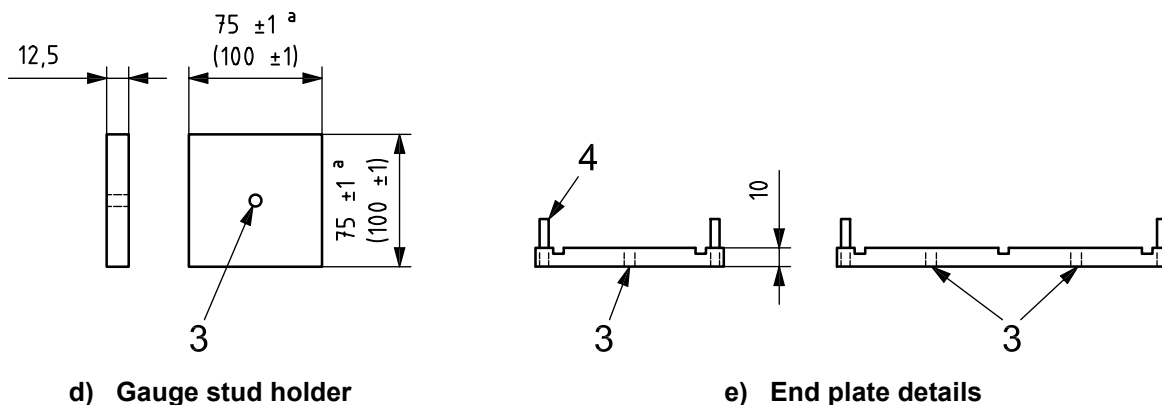

Key

- 1 gauge stud holder retaining screw
- 2 drill and tap with an M6 × 1-6g thread (to take baseplate screw)
- 3 drill and tap centrally with an M6 × 1-6g thread (to take gauge stud and spacer screw)
- 4 dowel pin Ø5 press fitted in end plate

^a The dimensions in Figure 1 refer to a mould suitable for casting specimens having dimensions of (75 × 75 × 280) mm. The dimensions in parentheses refer to a mould suitable for casting specimens having dimensions of (100 × 100 × 400) mm.

Figure 1 — Details of a typical mould

Dimensions in millimetres

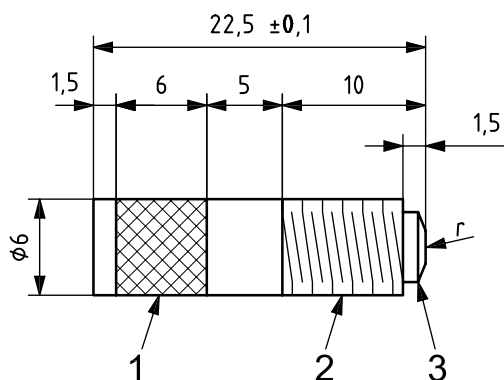

a) Gauge stud for (75 × 75 × 280) mm specimen

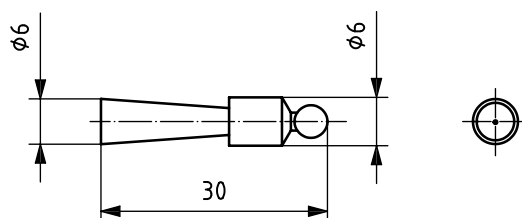

b) Gauge stud for (100 × 100 × 400) mm specimen

Key

- 1 coarse knurl
- 2 thread M6 × 1-6g
- 3 buff tip to a polished finish

Figure 2 — Details for typical gauge studs

5.8 Length comparator, used for measuring changes in length.

5.8.1 General

The comparator shall be capable of measuring the length of specimens over a range of 290 mm to 300 mm for specimens of (75 × 75 × 280) mm, and over a range of 415 mm to 425 mm for specimens of (100 × 100 × 400) mm. The precision of the measurement shall be 0,001 mm.

It is recommended that, where a horizontal comparator is used, micrometers be of the digital read-out type. Details of a suitable horizontal length comparator are provided in Annex A.

5.8.2 Reference bar

A specific reference bar made of a material characterized by an extremely low coefficient of thermal expansion shall be used with each comparator.

- a) For specimens having dimensions of 75 mm × 75 mm × 280 mm
- the diameter of the reference bar shall be not less than 6 mm, and
 - the overall length of the reference bar shall be $(295 \pm 1,5)$ mm;
- b) For specimens having dimensions of 100 mm × 100 mm × 400 mm
- the diameter of the reference bar shall be not less than 10 mm, and
 - the overall length of the reference bar shall be $(420 \pm 1,5)$ mm.

Each end shall be reduced in diameter and the end 5 mm shall have approximately the same diameter and have the same end radius as the projecting end of the gauge stud (5.3) being used in the specimen. Each end of the reference bar shall be polished.

The central section of the reference bar shall be covered by a rubber tube, or equivalent, of length approximately 100 mm and wall thickness of at least 3 mm to minimize the effect of temperature change during handling. The reference bar shall be provided with a positioning mark and shall always be placed in the comparator in the same orientation.

5.8.3 Check of precision

The precision of the length comparator and the performance of the operator shall be checked by recording the difference in length between the reference bar and a typical specimen 20 times, replacing each in the comparator for each reading. The standard deviation of these 20 length differences shall not exceed 0,002 mm. When a check of precision fails to meet this requirement, further checks shall be made with another specimen or with another operator to ascertain whether the lack of precision is associated with the comparator or with the operator.

The frequency of the checking shall conform with the quality management programme of the laboratory.

6 Test samples and specimens

6.1 Sampling

Specimens may be prepared either in the laboratory or in the field. Particular care should be taken to ensure that sampling and preparation are strictly in accordance with Clause 6, as these activities are crucial to the accuracy and repeatability of the test. Full records should also be kept for inclusion in the report (see Clause 9 and Clause 10).

For concrete sampled in the field, the test sample shall be obtained in accordance with ISO 1920-1.

6.2 Test specimens

6.2.1 General

At least three specimens shall be prepared from each sample of concrete.

6.2.2 Size and shape of standard test specimens

The test specimen shall be a prism of 75 mm × 75 mm and approximately 280 mm long, or a prism of 100 mm × 100 mm and approximately 400 mm long. A stainless steel gauge stud (5.3) shall be cast into each end of the specimen. The gauge studs shall be cast so that their principal axes coincide with the principal axis of the test specimen and shall extend into the specimen approximately 15 mm for specimens having dimensions of 75 mm × 75 mm × 280 mm and approximately 20 mm for specimens having dimensions of 100 mm × 100 mm × 400 mm.

6.2.3 Identification of specimens

Each specimen shall be identified by the mould marking or by other means that will not adversely affect the concrete. Scratch markings shall not be used.

The use of permanent markings on the external face of the mould (5.2) is recommended.

7 Procedure

7.1 Measurement of consistence and temperature of concrete

- a) Measure slump and, if required, other determination of the consistence of the concrete, in accordance with ISO 1920-2, and record it.
- b) Measure and record the temperature of the concrete at the time of moulding.

7.2 Preparation and filling of the moulds

- a) Prepare the specimens as required in ISO 1920-3:2004, 6.2.
- b) Prepare the gauge stud assembly as follows:
 - 1) lubricate the threading of the gauge stud holder;
 - 2) screw the gauge stud (5.3) into the gauge stud holder, taking care that no mineral oil or other contaminant remains on the surface of the gauge stud that comes into contact with the concrete;
 - 3) using the length gauge (5.4), set the effective gauge length, i.e. the length between the innermost ends of the gauge studs, at 250 mm for 75 mm × 75 mm × 280 mm specimens and at 360 mm for 100 mm × 100 mm × 400 mm specimens.

7.3 Compacting of concrete

Compact the concrete by tamping or vibrating, as appropriate, as described in 7.3, without causing segregation or excessive laitance.

Compaction by tamping is not recommended for concrete with a slump less than 40 mm, nor is vibration recommended for concrete with a slump greater than 100 mm.

NOTE The objective is to achieve full compaction.

To compact by tamping, compact the concrete as required in ISO 1920-3:2004, Clause D.4 and Clause D.5.

To compact by vibration, compact the concrete as required in ISO 1920-3:2004, Clause D.3.

7.4 Curing of specimens

7.4.1 Initial curing in moulds

7.4.1.1 General

Immediately after the test specimen has been moulded, place the mould (5.2) containing the specimen in the initial curing environment and loosen the gauge stud holder retaining screws so as to prevent restraint of the gauge stud (5.3) in case of shrinkage of the concrete during initial curing.

7.4.1.2 Initial curing under standard conditions

Store the specimens in saturated conditions, undisturbed in their moulds (5.2), on a rigid horizontal surface, in the relevant conditions required in ISO 1920-3:2004, Clause 7.

7.4.1.3 Storage of moulded specimens in the field

In the field, store the moulded specimens for a period of not less than 18 h and not more than 24 h from moulding, as follows.

- a) In a covered location adjacent to the moulding site, preferably indoors and protected from wind and extremes of temperature.
- b) Undisturbed in their moulds (5.2) on a rigid horizontal surface, with lids fitted so as to prevent the loss of moisture from the specimen.

NOTE The aim is to provide conditions for test specimens which give a maximum of protection from extremes of temperature and loss of moisture during their storage in the field.

7.4.1.4 Initial curing under field conditions

As soon as is practicable after a period of 18 h from moulding, transport the specimens which were stored in accordance with 7.4.1.3 to the laboratory for demoulding, such that they are placed under standard moist curing conditions (see 3.1) within 24 h of moulding.

7.4.2 Demoulding of specimens

7.4.2.1 General

Demould specimens within (24 ± 2) h from the time of moulding. Where variations to this time period are necessary, standard moist curing conditions shall be maintained during any additional curing period and full details shall be noted in the report.

Minor damage to the gauge studs (5.3) may be repaired; however, the extent of this damage and details of any repairs carried out shall be noted and reported.

Take extreme care to ensure that the gauge stud is not disturbed while the gauge stud holder is being unscrewed from the stud.

If the damage to the gauge studs is restricted to dislodgment of one or both gauge studs, the studs may be carefully cemented in place by means of a suitable fast-setting cement, e.g. a catalyzed epoxy or polyester. It is, however, essential that the cement be allowed at least 24 h to harden before initial measurement.

7.4.2.2 Acceptance criteria

Specimens may be rejected if there is evidence of poor compaction or damage, e.g. cracks, or loose studs.

7.4.2.3 Identification of specimens

As it is removed from its mould (5.2), mark each specimen with a suitable indelible marker to show identification.

Specimens may also be marked at this time for orientation [see 7.5.3.3 b)].

7.4.3 Standard moist curing

Except where minor repairs are necessary, place specimens in standard moist curing conditions (see 3.1) within 15 min of demoulding. Maintain these conditions until 7 days from moulding, subject to the alternative requirements for transport set out in 7.4.4.

Demoulded specimens may be transported from the preparing laboratory to the measuring laboratory (see 7.4.4) during the standard moist curing period after a minimum period of 24 h in standard moist curing conditions in the preparing laboratory.

Store all specimens in standard moist curing conditions at the measuring laboratory for a minimum of 24 h prior to initial measurement.

7.4.4 Transport of specimens to the measuring laboratory

When specimens are transported to a laboratory, they shall be carried in such a way that physical damage is avoided and loss of moisture and temperature extremes are prevented.

The transporting time, i.e., the total time during which the specimens are not in standard moist curing conditions, shall not exceed 24 h.

Specimens that arrive at the measuring laboratory other than in a saturated condition may be rejected.

Adequate protection may be obtained by wrapping the specimens with wet hessian or wet newspaper and packing in plastic bags within strong containers.

7.5 Drying and measurement of specimens

7.5.1 General

At an age of 7 days from moulding, remove the specimens one at a time from the water and wipe the surface dry with a damp cloth.

All drying and measurement of specimens shall be carried out in the drying room (5.1), with the temperature and relative humidity within the range specified in 5.1.

The length measurements shall be taken as described in 7.5.3 and 7.5.4, except if other measurement procedures are required by a national standard.

7.5.2 Setting the length comparator

Set the micrometer of the length comparator to zero, with the reference bar suitably held in a position which is accurately aligned with the measuring anvil.

7.5.3 Initial measurements

7.5.3.1 Mass of the concrete specimen

Measure the mass of each specimen to an accuracy of at least 0,1 g and record the measurement. Repeat taking replicate measurements until at least five consecutive determinations have been made, all of which are within 0,1 g of the average measurement. These measurements shall be completed within 2 min of removing the specimen from the water. Record the mean of these five determinations as the initial mass of the specimen.

7.5.3.2 Horizontal comparator

The procedure for taking the initial measurements with a horizontal comparator is as follows.

- a) Ensure that the ends of the gauge studs (5.3) are clean and polished.
- b) Immediately after wiping the surface dry, place the specimen in the comparator so that its axis is aligned with the measuring anvil and its top surface, as cast, does not bear on the locating supports of the comparator. Record the micrometer reading (length difference) when the anvils are in contact with the specimen.
- c) Remove the specimen and replace it in the comparator in the same orientation. Repeat taking replicate measurements until at least five consecutive determinations have been made, all of which are within 0,001 mm of the average measurement. These readings shall be completed within 2 min of removing the specimen from the water. Record the mean of these five determinations as the initial measurement.
- d) Place the specimens on racks in the drying room (5.1) so that there is a clearance of at least 50 mm on all sides, except for the necessary support. All storage positions shall be kept occupied at all times, with dummy specimens if necessary. It is recommended that dummy specimens be concrete prisms with the same dimensions as the test specimens.
- e) Using the reference bar, check the zero setting of the comparator at appropriate time intervals during measurement. Where the comparator is found to have varied by more than 0,002 mm, all readings taken since the previous reference bar check shall be repeated.

7.5.3.3 Vertical comparator

The procedure for taking the initial measurements with a vertical comparator is as follows.

- a) At an age of 7 days from moulding, remove the specimens one at a time from the water and wipe the surface dry with a damp cloth.
- b) Mark each specimen to identify one end as the top. These markings shall be made on one cast face of each specimen only, and the marked face shall be the front.
- c) Before each specimen is measured, wipe both stud ends to remove any dust particles. Also wipe clean both the base anvil and the dial gauge anvil. If the specimen is incorrectly located, the bottom concrete surface may bear on the base anvil. If this occurs, the specimen should be removed from the comparator, so that all dust can be cleaned from the anvil before that specimen is measured.
- d) Immediately after wiping the surface dry, place each specimen in the comparator by first positioning the bottom gauge stud (5.3) in the base anvil. Then raise the dial gauge anvil, make the specimen vertical and lower the dial gauge anvil into position on the top gauge stud.
- e) While ensuring that the gauge is correctly seated, rotate the specimen axially until the front face is parallel to the face of the dial gauge and facing the operator. Read the dial gauge and record the reading.

NOTE A light downward force applied to the dial gauge anvil or shaft together with rotation of the specimen can assist in correctly seating the dial gauge.

- f) Remove the specimen and replace it in the comparator in the same orientation. Continue taking replicate measurements until at least five consecutive determinations have been made, all of which are within 0,001 mm of the average measurement. These readings shall be completed within 2 min of removing the specimen from the water. Record the mean of these five determinations as the initial measurement.
- g) Place the specimens on racks in the drying room (5.1) so that there is a clearance of at least 50 mm on all sides, except for the necessary support. All storage positions shall be kept occupied at all times, with dummy specimens if necessary. It is recommended that dummy specimens be concrete prisms with the same dimensions as the test specimens.
- h) Using the reference bar, check the zero setting of the comparator at appropriate time intervals during measurement. Where the comparator is found to have varied by more than 0,002 mm, all readings taken since the previous reference bar check shall be repeated.

7.5.4 Subsequent measurements

The procedure for taking the subsequent measurements using either form of comparator is as follows.

- a) Take the weight measurement and the length measurement for each specimen as set out in Clause 7.5.3.1 and Clause 7.5.3.2 c) or 7.5.3.3 f) as appropriate after total periods of air drying of 7, 14, 21, 28, 56 and 112 days, as required, and any other specifically requested drying periods. Continue the measurements at least up to 3 months. A single measurement for each specimen (i.e. not an average of five or more) will normally be adequate. With non-digital micrometers, a second check-reading is recommended.
- b) Check the zero setting of the comparator as set out in 7.5.3.2 e) or 7.5.3.3 h), as appropriate.

8 Calculation and expression of results

The following results shall be calculated and recorded:

- a) For each period of drying time, subtract the mass of the specimen, in grams, at that time from the mean initial mass, in grams.
- b) For each period of drying time, subtract the length measurement, in millimetres, at that time from the mean initial length measurement, in millimetres.
- c) Divide the difference obtained from item 8 b) by the original effective gauge length, which shall be taken as 250 mm for specimens of 75 mm × 75 mm × 280 mm and as 360 mm for specimens of 100 mm × 100 mm × 400 mm.
- d) Express the result, drying shrinkage, in microstrain.
- e) For each drying period for the one sample of concrete, calculate the average drying shrinkage of only the individual results which are within 10 % microstrain of the median value result.

9 Test report

Where the measuring laboratory is not the preparing laboratory, each laboratory shall prepare separate reports which, when combined, shall constitute the complete report.

- a) The report of the preparing laboratory shall include the following:
 - 1) identification of specimen;
 - 2) field or laboratory sampled;

- 3) date and time of moulding;
 - 4) job site or laboratory where moulded;
 - 5) initial curing period, i.e.
 - standard, or laboratory, and
 - non-standard, including details of field curing;
 - 6) date and time of demoulding;
 - 7) any damage to the specimen and details of any repairs carried out, where applicable;
 - 8) date and time of despatch;
 - 9) such other information contained in the records as may be requested;
 - 10) any deviation from the standard test method;
 - 11) a declaration from the person technically responsible for the test that the testing was carried out in accordance with ISO 1920-8, except as noted in 9 a) 10).
- b) The report of the measuring laboratory shall include the following:
- 1) identification of specimen;
 - 2) date and time of receipt;
 - 3) any damage to the specimen and details of any repairs carried out, where applicable;
 - 4) method of compaction;
 - 5) slump and other consistence determination of the concrete, if required;
 - 6) temperature of concrete immediately prior to moulding;
 - 7) initial curing history of specimens, i.e. standard or non-standard including, if non-standard
 - maximum and minimum temperatures to which specimens have been subjected, and
 - dates and times of despatch and receipt of transported specimens;
 - 8) moisture condition of specimen when received at the measuring laboratory, i.e. saturated or not;
 - 9) drying room temperature, humidity and evaporation rates;
 - 10) date of initial measurement;
 - 11) initial mass of specimen;
 - 12) initial length readings of each specimen;
 - 13) subsequent length reading for each specimen, i.e.
 - date,
 - duration of drying period, and

- reading of length comparator for specimen;
- 14) drying shrinkage for each specimen and the average for each set, at each required drying period, to the nearest 5 microstrain;
- 15) such other information contained in the records as may be requested;
- 16) any deviation from the standard method;
- 17) a declaration from the person technically responsible for the test that the testing was carried out in accordance with ISO 1920-8, except as noted in 9 b) 16).

10 Precision for laboratory-prepared specimens

For a set of three specimens moulded in the laboratory from the same sample of concrete cured under identical conditions and with a nominal aggregate size (see ISO 6274) not greater than 20 mm, the repeatability expressed as a percentage of the mean of the set of three specimens is 8 % at the 95 % probability level.

Precision data are not available for field-moulded specimens or specimens prepared in a laboratory other than the measuring laboratory. (This statement on repeatability is based on limited Australian data and may be amended when more data are collected.)

Annex A (informative)

A suitable horizontal length comparator

A.1 General

The comparator for measuring length changes should be capable of measuring the length of specimens over a range of 290 mm to 300 mm, for specimens of 75 mm × 75 mm × 280 mm, and over a range of 415 mm to 425 mm for specimens of 100 mm × 100 mm × 400 mm. The precision of the measurement shall be 0,001 mm. It should consist of a frame for supporting the specimen during measurement, in such a way that no weight is carried by the gauge studs (5.3) and a measuring device, e.g. a micrometer with an accuracy of 0,001 mm.

This Annex sets out recommendations for a comparator which holds the specimen in a horizontal position or in a vertical position and uses a micrometer for measurement (see Figure A.1 and Figure A.2).

A.2 Comparator frame

The frame should be capable of supporting the specimen horizontally and of locating it in a reproducible position parallel to the axis of the frame and perpendicular to the measuring anvils, which should contact the gauge studs (5.3) as near as possible to the centres of the anvils. The frame should be rigid enough to prevent distortion during normal handling of the specimen, so that the micrometer reading is not affected by touching the specimen during measurement.

The diameters of the measuring anvils should be between 6 mm and 10 mm. The surfaces of the anvils should be made of tungsten carbide and should be flat. One anvil should be fixed in relation to the frame and should be attached to a pedestal. The other anvil should be attached to, or be part of the shaft of, the micrometer, which should be firmly attached to a similar pedestal. The orientation of the pedestals relative to the base of the frame should be adjustable so as to bring the anvils into the correct measuring position.

The anvils should be parallel to each other at all times during use, and perpendicular to the axis of the frame. The distances between horizontally opposite points on the two anvils should not vary by more than 0,001 mm from the distance measured between the centre points of the anvils.

A.3 Micrometer

The micrometer should be digitally indicating in units of 0,001 mm or less and accurate to within 0,001 mm in any 0,10 mm range with a total travel of at least 10 mm. It should be equipped with a zeroing device to enable the length of the reference bar to be set at zero. The shaft of the micrometer should be spring loaded and should be accurately aligned with the axis of the frame, with the anvil face perpendicular to the shaft. The orientation of the anvil should not be affected by movement of the shaft along its axis.

In use, the shaft of the micrometer will be retracted during loading of the specimen into the frame, one gauge stud (5.3) of the specimen then being brought into contact with the fixed anvil before the shaft is gently released, allowing it to contact the other gauge stud.

Dimensions in millimetres

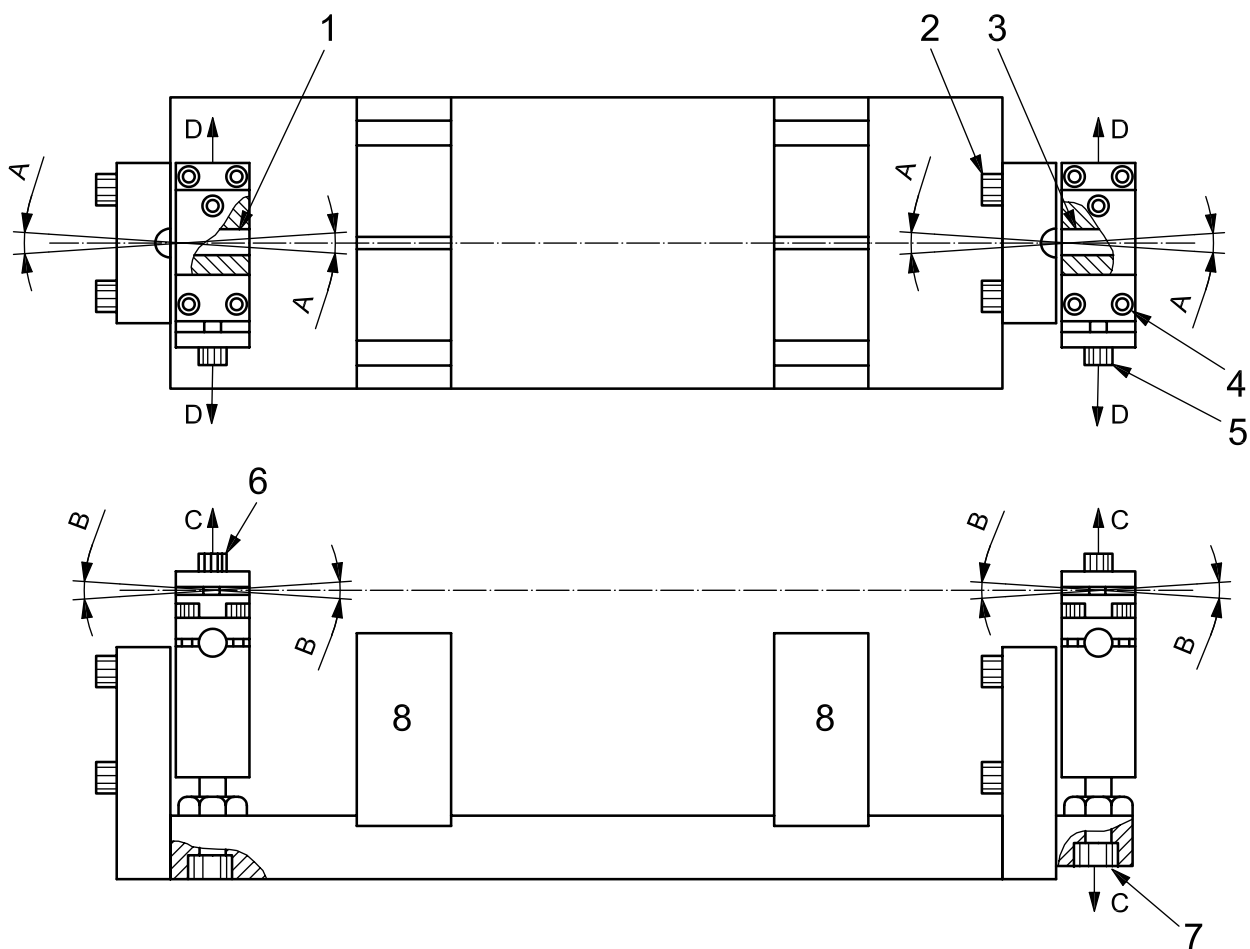

Key

- 1 ream to suit tungsten carbide anvil
- 2 four adjustment cap screws (A)
- 3 ream to suit digital read out
- 4 four adjustment cap screws (B)
- 5 one adjustment screw (C)
- 6 clamping cap screw
- 7 one adjustment screw (C)
- 8 v-block

NOTE Adjustment of screw A results in movement in direction A, as is the case with B, C and D.

Figure A.1 — Horizontal length comparator

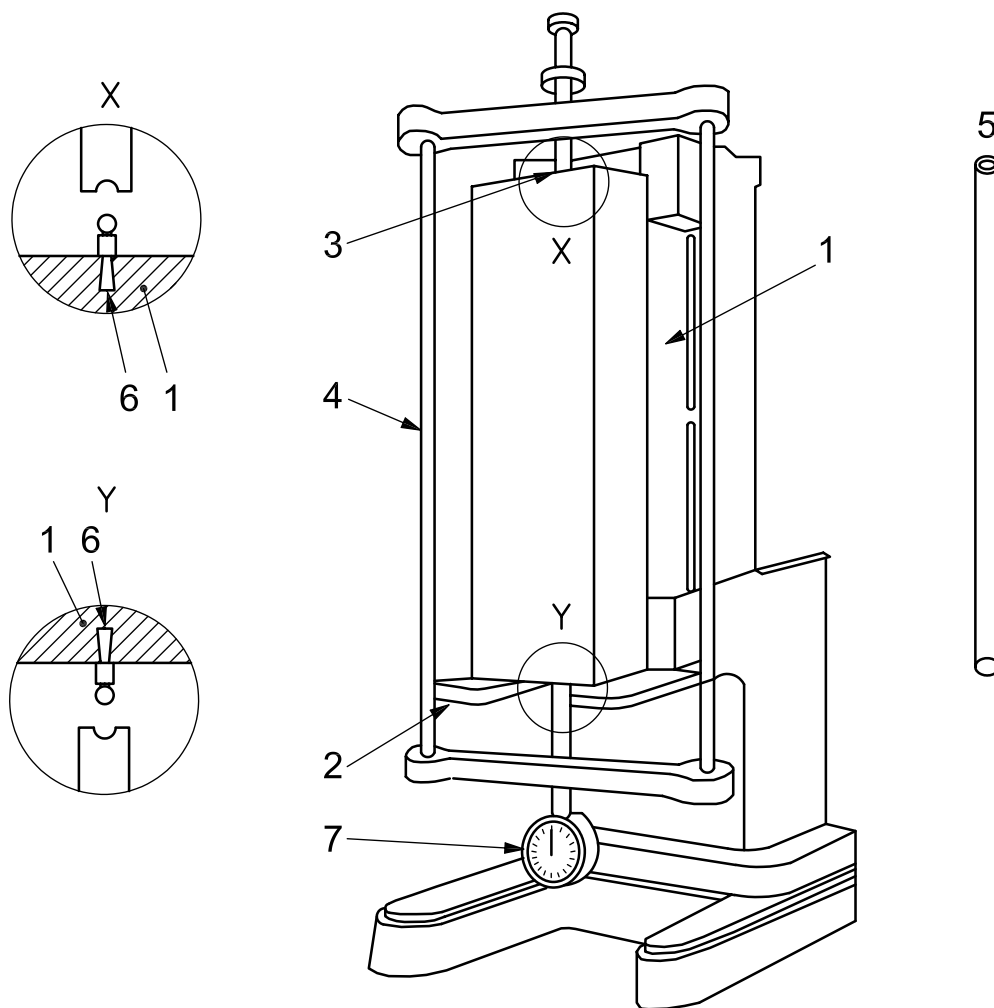

Key

- 1 specimen
- 2 base
- 3 point
- 4 frame for a measurement
- 5 reference bar
- 6 gauge stud
- 7 dial gauge

Figure A.2 — Vertical length comparator

ICS 91.100.30

Price based on 17 pages

BSI - British Standards Institution

BSI is the independent national body responsible for preparing British Standards. It presents the UK view on standards in Europe and at the international level. It is incorporated by Royal Charter.

Revisions

British Standards are updated by amendment or revision. Users of British Standards should make sure that they possess the latest amendments or editions.

It is the constant aim of BSI to improve the quality of our products and services. We would be grateful if anyone finding an inaccuracy or ambiguity while using this British Standard would inform the Secretary of the technical committee responsible, the identity of which can be found on the inside front cover. Tel: +44 (0)20 8996 9000. Fax: +44 (0)20 8996 7400.

BSI offers members an individual updating service called PLUS which ensures that subscribers automatically receive the latest editions of standards.

Buying standards

Orders for all BSI, international and foreign standards publications should be addressed to Customer Services. Tel: +44 (0)20 8996 9001. Fax: +44 (0)20 8996 7001 Email: orders@bsigroup.com You may also buy directly using a debit/credit card from the BSI Shop on the Website <http://www.bsigroup.com/shop>

In response to orders for international standards, it is BSI policy to supply the BSI implementation of those that have been published as British Standards, unless otherwise requested.

Information on standards

BSI provides a wide range of information on national, European and international standards through its Library and its Technical Help to Exporters Service. Various BSI electronic information services are also available which give details on all its products and services. Contact Information Centre. Tel: +44 (0)20 8996 7111 Fax: +44 (0)20 8996 7048 Email: info@bsigroup.com

Subscribing members of BSI are kept up to date with standards developments and receive substantial discounts on the purchase price of standards. For details of these and other benefits contact Membership Administration. Tel: +44 (0)20 8996 7002 Fax: +44 (0)20 8996 7001 Email: membership@bsigroup.com

Information regarding online access to British Standards via British Standards Online can be found at <http://www.bsigroup.com/BSOL>

Further information about BSI is available on the BSI website at <http://www.bsigroup.com>

Copyright

Copyright subsists in all BSI publications. BSI also holds the copyright, in the UK, of the publications of the international standardization bodies. Except as permitted under the Copyright, Designs and Patents Act 1988 no extract may be reproduced, stored in a retrieval system or transmitted in any form or by any means – electronic, photocopying, recording or otherwise – without prior written permission from BSI.

This does not preclude the free use, in the course of implementing the standard, of necessary details such as symbols, and size, type or grade designations. If these details are to be used for any other purpose than implementation then the prior written permission of BSI must be obtained.

Details and advice can be obtained from the Copyright and Licensing Manager. Tel: +44 (0)20 8996 7070 Email: copyright@bsigroup.com