

BS ISO 1817:2015



BSI Standards Publication

Rubber, vulcanized or thermoplastic — Determination of the effect of liquids

bsi.

...making excellence a habit.™

National foreword

This British Standard is the UK implementation of ISO 1817:2015. It supersedes BS ISO 1817:2011 which is withdrawn.

The UK participation in its preparation was entrusted to Technical Committee PRI/22, Physical testing of rubber.

A list of organizations represented on this committee can be obtained on request to its secretary.

This publication does not purport to include all the necessary provisions of a contract. Users are responsible for its correct application.

© The British Standards Institution 2015.
Published by BSI Standards Limited 2015

ISBN 978 0 580 84005 0

ICS 83.060

Compliance with a British Standard cannot confer immunity from legal obligations.

This British Standard was published under the authority of the Standards Policy and Strategy Committee on 28 February 2015.

Amendments/corrigenda issued since publication

Date	Text affected
------	---------------

**Rubber, vulcanized or
thermoplastic — Determination of the
effect of liquids**

*Caoutchouc vulcanisé ou thermoplastique — Détermination de
l'action des liquides*





COPYRIGHT PROTECTED DOCUMENT

© ISO 2015

All rights reserved. Unless otherwise specified, no part of this publication may be reproduced or utilized otherwise in any form or by any means, electronic or mechanical, including photocopying, or posting on the internet or an intranet, without prior written permission. Permission can be requested from either ISO at the address below or ISO's member body in the country of the requester.

ISO copyright office
Case postale 56 • CH-1211 Geneva 20
Tel. + 41 22 749 01 11
Fax + 41 22 749 09 47
E-mail copyright@iso.org
Web www.iso.org

Published in Switzerland

Contents

Page

Foreword	iv
Introduction	v
1 Scope	1
2 Normative references	1
3 Apparatus	1
4 Calibration	3
5 Test liquids	3
6 Test pieces	3
6.1 Preparation.....	3
6.2 Dimensions.....	3
6.3 Time interval between vulcanization and testing.....	4
6.4 Conditioning.....	4
7 Immersion in the test liquid	4
7.1 Temperature.....	4
7.2 Duration.....	5
8 Procedure	5
8.1 General.....	5
8.2 Change in mass.....	6
8.3 Change in volume.....	6
8.4 Change in dimensions.....	7
8.5 Change in surface area.....	8
8.6 Change in hardness.....	8
8.7 Change in tensile stress-strain properties.....	9
8.8 Testing with liquid on one surface only.....	9
8.9 Determination of extractable matter.....	10
9 Precision	11
10 Test report	11
Annex A (normative) Reference liquids	12
Annex B (normative) Calibration schedule	15
Annex C (informative) Precision results from an interlaboratory test programme	17
Bibliography	23

Foreword

ISO (the International Organization for Standardization) is a worldwide federation of national standards bodies (ISO member bodies). The work of preparing International Standards is normally carried out through ISO technical committees. Each member body interested in a subject for which a technical committee has been established has the right to be represented on that committee. International organizations, governmental and non-governmental, in liaison with ISO, also take part in the work. ISO collaborates closely with the International Electrotechnical Commission (IEC) on all matters of electrotechnical standardization.

The procedures used to develop this document and those intended for its further maintenance are described in the ISO/IEC Directives, Part 1. In particular the different approval criteria needed for the different types of ISO documents should be noted. This document was drafted in accordance with the editorial rules of the ISO/IEC Directives, Part 2 (see www.iso.org/directives).

Attention is drawn to the possibility that some of the elements of this document may be the subject of patent rights. ISO shall not be held responsible for identifying any or all such patent rights. Details of any patent rights identified during the development of the document will be in the Introduction and/or on the ISO list of patent declarations received (see www.iso.org/patents).

Any trade name used in this document is information given for the convenience of users and does not constitute an endorsement.

For an explanation on the meaning of ISO specific terms and expressions related to conformity assessment, as well as information about ISO's adherence to the WTO principles in the Technical Barriers to Trade (TBT) see the following URL: Foreword - Supplementary information

The committee responsible for this document is ISO/TC 45, *Rubber and rubber products*, Subcommittee SC 2, *Testing and analysis*.

This sixth edition cancels and replaces the fifth edition (ISO 1817:2011), which has been revised to include a precision statement (see [Annex C](#)). Additionally, the flash point of oil No. 2 has been adjusted to the actual value and the CAS (Chemical Abstracts Service) numbers have been incorporated in [Table A1](#) and [A2](#) as well as in [Clause A.3](#).

Introduction

The action of a liquid on vulcanized or thermoplastic rubber can generally result in:

- a) absorption of the liquid by the rubber;
- b) extraction of soluble constituents from the rubber;
- c) a chemical reaction with the rubber.

The amount of absorption [a]) is usually larger than that of extraction [b]) so that the net result is an increase in volume, commonly termed “swelling”. The absorption of liquid can profoundly alter physical and chemical properties and hence change tensile strength, extensibility and hardness of the rubber, so it is important to measure these properties after treatment of the rubber. The extraction of soluble constituents, especially plasticizers and antidegradants, can likewise alter the rubber’s physical properties and chemical resistance after drying (assuming the liquid to be volatile). Therefore, it is necessary to test these properties following immersion and drying of the rubber. This International Standard describes the methods necessary for determining the changes in the following properties:

- change in mass, volume and dimensions;
- extractable matter;
- change in hardness and tensile stress-strain properties after immersion and after immersion and drying.

Although in some respects these tests might simulate service conditions, no direct correlation with service behaviour is implied. Thus, the rubber giving the lowest change in volume is not necessarily the best one in service. The thickness of the rubber needs to be taken into account since the rate of penetration of liquid is time-dependent and the bulk of a very thick rubber product might remain unaffected for the whole of the projected service life, especially with viscous liquids. Moreover, it is known that the action of a liquid on rubber, especially at high temperatures, can be affected by the presence of atmospheric oxygen. The tests described in this International Standard can, however, provide valuable information on the suitability of a rubber for use with a given liquid and, in particular, constitute a useful control when used for developing rubbers resistant to oils, fuels, or other service liquids.

The effect of a liquid might depend on the nature and magnitude of any stress within the rubber. In this International Standard, test pieces are tested in an unstressed condition.

Rubber, vulcanized or thermoplastic — Determination of the effect of liquids

WARNING 1 — Persons using this document should be familiar with normal laboratory practice. This document does not purport to address all of the safety problems, if any, associated with its use. It is the responsibility of the user to establish appropriate safety and health practices and to ensure compliance with any national regulatory conditions.

WARNING 2 — Certain procedures specified in this document might involve the use or generation of substances, or the generation of waste, that could constitute a local environmental hazard. Reference should be made to appropriate documentation on safe handling and disposal after use.

1 Scope

This International Standard describes methods of evaluating the resistance of vulcanized and thermoplastic rubbers to the action of liquids by measurement of properties of the rubbers before and after immersion in test liquids. The liquids concerned include current service liquids, such as petroleum derivatives, organic solvents and chemical reagents, as well as reference test liquids.

2 Normative references

The following referenced documents are indispensable for the application of this document. For dated references, only the edition cited applies. For undated references, the latest edition of the referenced document (including any amendments) applies.

ISO 37, *Rubber, vulcanized or thermoplastic — Determination of tensile stress-strain properties*

ISO 48, *Rubber, vulcanized or thermoplastic — Determination of hardness (hardness between 10 IRHD and 100 IRHD)*

ISO 175, *Plastics — Methods of test for the determination of the effects of immersion in liquid chemicals*

ISO 7619-1, *Rubber, vulcanized or thermoplastic — Determination of indentation hardness — Part 1: Durometer method (Shore hardness)*

ISO 18899:2013, *Rubber — Guide to the calibration of test equipment*

ISO 23529:2010, *Rubber — General procedures for preparing and conditioning test pieces for physical test methods*

ASTM D5964, *Standard Practice for Rubber IRM 901, IRM 902, and IRM 903 Replacement Oils for ASTM No. 1, ASTM No. 2, and ASTM No. 3 Oils*

3 Apparatus

3.1 Total immersion apparatus, designed to take account of the volatility of the test liquid and of the immersion temperature in order to prevent and minimize evaporation of the test liquid and the ingress of air.

For tests at temperatures considerably below the boiling point of the test liquid, a stoppered glass bottle or tube shall be used. For tests at temperatures near the boiling point of the test liquid, the bottle or tube shall be fitted with a reflux condenser or other suitable means of minimizing the evaporation of liquid.

The bottle or tube shall be so dimensioned that the test pieces remain completely immersed and all surfaces are completely exposed to the liquid without any restriction. The volume of liquid shall be at least 15 times the combined volume of the test pieces and the volume of air above the liquid shall be kept to a minimum.

The test pieces shall be mounted in jigs, preferably hanging on a rod or wire, and separated from any adjacent test piece, for instance by glass rings or other non-reactive spacers.

The materials of the apparatus shall be inert to the test liquid and to the rubber; for example, materials containing copper shall not be used.

3.2 Apparatus for testing one surface only, which holds the test piece in contact with the liquid on only one of its surfaces.

A suitable apparatus is illustrated in [Figure 1](#). It comprises a base-plate (A) and an open-ended cylindrical chamber (B), which is held tightly against the test piece (C) by wing nuts (D) mounted on bolts (E). A hole of approximately 30 mm diameter is allowed in the base-plate for examination of the surface not in contact with the liquid. During the test, the opening on the top of the chamber shall be closed by a close-fitting plug (F).

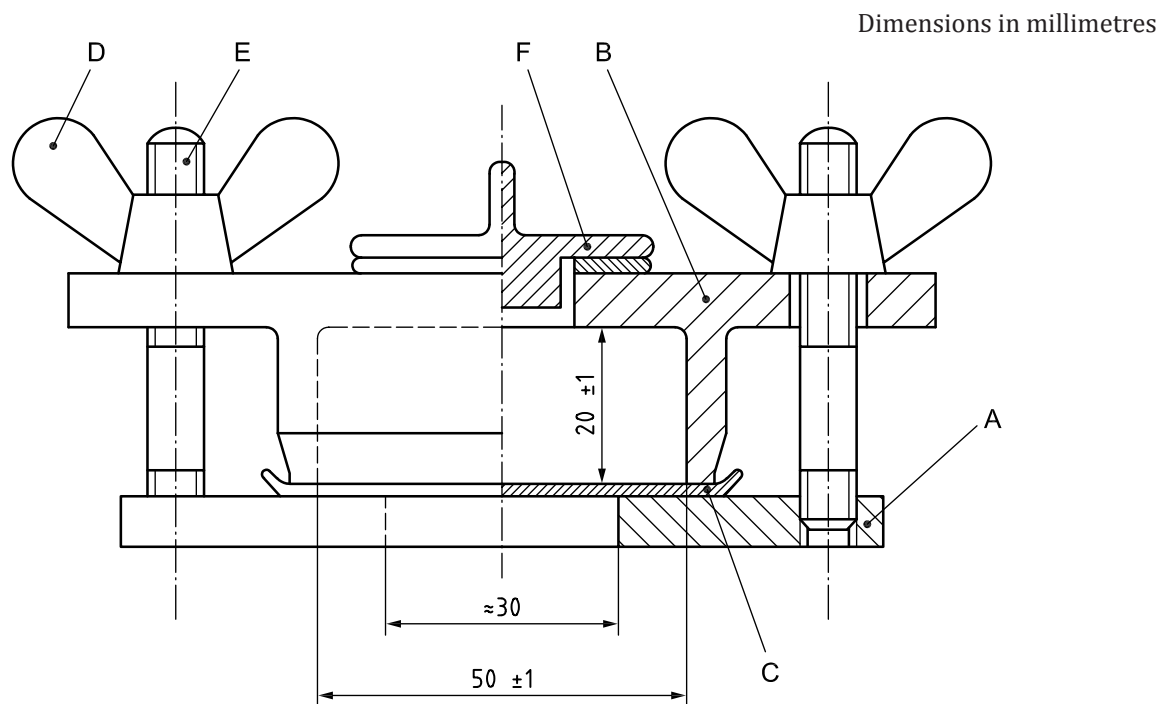

Figure 1 — Apparatus for testing one surface only

3.3 Balance, accurate to 1 mg.

3.4 Instrument for measuring the thickness of the test piece, consisting of a micrometre dial gauge, of adequate accuracy, firmly held in a rigid stand over a flat base-plate. The instrument shall comply with the requirements given for such apparatus in ISO 23529:2010, method A.

3.5 Instrument for measuring the length and width of the test piece, having a scale graduated in divisions of 0,01 mm and preferably operating without contact with the test piece, for example using an optical system complying with the requirements given for such apparatus in ISO 23529:2010, method D.

3.6 Instrument for measuring the change in surface area, capable of measuring the lengths of the diagonals of the test piece. It shall have a scale graduated in divisions of 0,01 mm and should preferably

operate without contact with the test piece, for example using an optical system complying with the requirements given for such apparatus in ISO 23529:2010, method D.

4 Calibration

The requirements for calibration of the test apparatus are given in [Annex B](#).

5 Test liquids

The choice of the test liquid shall depend on the purpose of the test.

When information is required on the service behaviour of a vulcanized or thermoplastic rubber in contact with a particular liquid, then this liquid shall, if possible, be chosen for the test. Commercial liquids are not always constant in composition, and the test shall, whenever practicable, include a reference material of known characteristics. Any abnormal results due to unexpected variations in the composition of the commercial liquid will thus become apparent. It might then be necessary to set aside a bulk supply of the liquid for a particular series of tests.

Mineral oils and fuels are liable to vary considerably in chemical composition even when supplied at a recognized specification. The aniline point of a mineral oil gives some indication of its aromatic content and helps to characterize the action of the oil on rubber, but the aniline point alone is not sufficient to characterize a mineral oil; other things being equal, the lower the aniline point, the more pronounced the action. If a mineral oil is used as test liquid, the test report shall include the density, refractive index, viscosity and aniline point or aromatic content of the oil.

Service oils having similar fluid characteristics to the reference liquids (see [Clauses A.1](#) to [A.3](#)) will not necessarily have the same effect on the material as the reference liquids. Some fuels, particularly gasoline, vary widely in composition and, for some possible constituents, minor variations can have a large influence on the effect on rubber. Complete details of the composition of the fuel used shall therefore be included in the test report.

As commercial liquids do not always have a constant composition, a standard liquid consisting of well-defined chemical compounds or mixtures of compounds shall be used as reference liquid for the purpose of classification of vulcanized or thermoplastic rubbers or quality control. Some suitable liquids are listed in [Annex A](#).

When testing to determine the effect of chemical solutions, the concentration of the solution shall be appropriate to the intended use.

Ensure that the composition of the test liquid does not change significantly during immersion. The ageing of the test liquid and any interaction with the test pieces shall be taken into consideration. If there are chemically active additives in the liquid, or if there is a significant change in composition by extraction, absorption or reaction with the rubber, either the volume shall be increased or the liquid shall be replaced with fresh liquid at specified intervals.

6 Test pieces

6.1 Preparation

Test pieces shall be prepared in accordance with ISO 23529:2010.

6.2 Dimensions

Data obtained on test pieces having different original thicknesses might not be comparable. Therefore, where possible, test pieces shall be of uniform thickness of $(2 \pm 0,2)$ mm.

Test pieces cut from commercial articles may be used. For products thinner than 1,8 mm, use the original thickness. If the material is thicker than 2,2 mm, reduce the thickness to $(2 \pm 0,2)$ mm.

Test pieces for the determination of the change in volume and mass shall have a volume of 1 cm³ to 3 cm³.

Test pieces for the determination of the change in hardness shall have lateral dimensions of no less than 8 mm.

Test pieces for the determination of the change in dimensions shall be quadrilateral with sides between 25 mm and 50 mm in length, or circular with a diameter of 44,6 mm (internal diameter of type B test piece in ISO 37). This type of test piece can also be used for the determination of mass and volume.

Test pieces for the determination of the change in surface area shall be rhomboid, with the sides cut cleanly and at right angles to the top and bottom surfaces. This can be achieved by two consecutive cuts at approximately right angles to each other, with a cutter consisting of two parallel blades, suitably spaced. The length of the sides shall be nominally 8 mm.

NOTE For the determination of the change in surface area, it might be convenient to use smaller or thinner test pieces, for example when cut from products or when rapid attainment of equilibrium is required. However, the results might not be comparable with those obtained using the specified thickness. Smaller test pieces will reduce the precision of the results.

Test pieces for the determination of tensile properties shall be in accordance with ISO 37. Type 2 dumbbells are preferred because their size makes them more convenient to immerse in liquid than type 1. The type 2 test piece can also be used when determining the change in mass, volume or hardness.

For tests with liquid contact on one surface only, the test piece shall consist of a disc with a diameter of about 60 mm.

6.3 Time interval between vulcanization and testing

Unless otherwise specified for technical reasons, the following requirements, in accordance with ISO 23529:2010 for time intervals, shall be observed.

For all test purposes, the minimum time between vulcanization and testing shall be 16 h.

For non-product tests, the maximum time between vulcanization and testing shall be 4 weeks and, for evaluations intended to be comparable, the tests shall be carried out using, as far as possible, the same time interval.

For product tests, whenever possible, the time between vulcanization and testing shall not exceed 3 months. In other cases, tests shall be made within 2 months of the date of receipt of the product by the customer.

6.4 Conditioning

Test pieces for test in the "as received" condition shall be conditioned for not less than 3 h at one of the standard laboratory temperatures specified in ISO 23529:2010. The same temperature shall be used throughout any test or any series of tests intended to be comparable.

7 Immersion in the test liquid

7.1 Temperature

Unless otherwise specified, the immersion shall be carried out at one or more of the temperatures listed in 8.2.2 of ISO 23529:2010.

As elevated temperatures can greatly increase the oxidation of the rubber, volatilization or decomposition of the immersion liquid and the effect of any chemically active additives in the liquid (for example in service liquids), appropriate selection of the test temperatures is very important.

In tests intended to simulate service conditions, and using the actual liquid with which the rubber will be used, the test conditions shall approximate to those found in service, using the closest standard temperature equal to or higher than the service temperature.

7.2 Duration

Since the rate of penetration of liquids into rubbers depends on the temperature, the type of rubber material and the type of liquid, the use of only one standard period of immersion is precluded. For acceptance purposes, it is recommended that repeated determinations be made and recorded after successive periods of immersion so as to indicate the change in properties with time. The total immersion time shall, if possible, extend well beyond the point of maximum absorption.

For control purposes, a single period of immersion can suffice, preferably chosen such that maximum absorption is reached. For such purposes, one of the following periods shall be used:

24_{-2}^0 h; 72_{-2}^0 h; 7 days \pm 2 h; multiples of 7 days \pm 2 h

NOTE 1 Since the amount of liquid absorbed is initially proportional to the square root of time rather than time itself, it is helpful to assess the "time to maximum absorption" by plotting the amount absorbed against the square root of time.

NOTE 2 The percentage change during the early stages of immersion is inversely proportional to the test piece thickness. Therefore, lower tolerances for thickness are advisable to obtain consistent results when maximum absorption is not reached.

8 Procedure

8.1 General

Use three test pieces for each set of measurements and make any identification marks required before immersion.

Immerse the test pieces in the appropriate apparatus described in [3.1](#) or [3.2](#), using the liquid selected (see [Clause 5](#)) and the temperature selected (see [7.1](#)).

For total immersion, place the test pieces at a distance of at least 5 mm from the sides of the container and at least 10 mm from the bottom and top surfaces. If the density of the rubber is less than that of the liquid, means shall be provided for holding the test pieces completely below the surface of the liquid.

The ingress of air shall be avoided. If the influence of air is to be tested, the degree of access of air shall be determined by agreement between the interested parties.

At the end of the period of immersion, bring the test pieces, if necessary, to the standard laboratory temperature within 30 min. This can be done by quickly transferring the test pieces to a fresh portion of the test liquid at this temperature and allowing to stand for a period of 10 min to 30 min.

Remove surplus test liquid from the surface. When volatile liquids are used, remove and quickly wipe the test pieces with a filter paper or a piece of lint-free fabric. Viscous non-volatile liquids can be removed by filter paper and, if necessary, by quickly immersing the test pieces in a volatile liquid, such as ethanol or petroleum ether, then quickly wiping them.

Following removal of the test pieces from volatile test liquids, it is important that each subsequent manipulation takes place as soon as possible. Carry out the tests immediately after the removal of surplus liquid or, for change in mass or volume, by placing the test piece immediately in a weighing bottle.

If, after the measurement of mass or dimensions, the same test pieces are used for the measurement of other properties, immerse the test pieces in the volatile liquid again. The total immersion time shall be in accordance with 7.2. The maximum time between removal from the test liquid and the end of the measurement shall, for a volatile liquid, be:

- change in dimensions: 1 min;
- change in hardness: 2 min;
- tensile test: 2 min.

If the immersion is to be continued, put the test pieces back in the liquid immediately and return them to the temperature-controlled oven or bath.

The changes in properties can also be determined after drying. For this purpose, dry the test pieces under an absolute air pressure of approximately 20 kPa at approximately 40 °C to constant mass, i.e. until the difference between successive weighings at 30 min intervals does not exceed 1 mg. Cool to room temperature and condition by keeping at the standard laboratory temperature for not less than 3 h.

8.2 Change in mass

Weigh each test piece to the nearest milligram at the standard laboratory temperature before and after immersion.

Calculate the percentage change in mass Δm_{100} using Formula (1):

$$\Delta m_{100} = \frac{m_i - m_0}{m_0} \times 100 \quad (1)$$

where

- m_0 is the initial mass of the test piece;
- m_i is the mass of the test piece after immersion.

Report the result as the median value for the three test pieces.

8.3 Change in volume

The water displacement method is used for test liquids which are immiscible with water.

Weigh each test piece in air to the nearest milligram (mass m_0), and then reweigh each test piece in distilled water at the standard laboratory temperature (mass $m_{0,w}$), taking care to ensure that all air bubbles are removed (a detergent can be used). If the density of the material is less than 1 g/cm³, it will be necessary to use a sinker when weighing in water to ensure that the test pieces are completely immersed. If a sinker is used, determine the mass of the sinker alone in distilled water separately (mass $m_{s,w}$). Blot the test pieces dry with filter paper or lint-free fabric.

Immerse each test piece in the test liquid. At the end of the period of immersion, weigh each test piece in air (mass m_i) to the nearest milligram, and then reweigh each test piece in distilled water (mass $m_{i,w}$), also at the standard laboratory temperature.

Calculate the percentage change in volume ΔV_{100} using Formula (2):

$$\Delta V_{100} = \left(\frac{m_i - m_{i,w} + m_{s,w}}{m_0 - m_{0,w} + m_{s,w}} - 1 \right) \times 100 \quad (2)$$

where

- m_0 is the initial mass of the test piece;
- m_i is the mass of the test piece after immersion;
- $m_{0,w}$ is the initial mass of the test piece (plus sinker if used) in water;
- $m_{i,w}$ is the mass of the test piece (plus sinker if used) after immersion in water;
- $m_{s,w}$ is the mass of the sinker, if used, in water.

Report the result as the median value for the three test pieces.

If the test liquid is readily miscible with water or reacts with it, water cannot be used after immersion. If the test liquid is not too viscous or volatile at room temperature, a fresh portion of the test liquid can be used. If the test liquid is not suitable, use another liquid after immersion and calculate using Formula (3):

$$\Delta V_{100} = \left[\frac{1}{\rho} \left(\frac{m_i - m_{i,liq} + m_{s,liq}}{m_0 - m_{0,w} + m_{s,w}} \right) - 1 \right] \times 100 \quad (3)$$

where

- ρ is the density of the liquid;
 - $m_{i,liq}$ is the mass of the test piece (plus sinker, if used) in the liquid;
 - $m_{s,liq}$ is the mass of the sinker, if used, in the liquid;
- the other symbols are as defined for Formula (2).

8.4 Change in dimensions

Measure the initial length of each test piece along its centre line to the nearest 0,5 mm at the standard laboratory temperature (taking measurements along the top and bottom surfaces and averaging the two results). Similarly, measure the initial width by taking four measurements in all (top and bottom, both sides) near each end of the test piece.

Measure the initial thickness with the thickness gauge at four different points along the test piece and calculate the average of the results.

After immersion, re-measure the length, width and thickness of each test piece as described above.

Make all measurements with the test piece at the standard laboratory temperature.

Calculate the percentage change in length Δl_{100} using Formula (4):

$$\Delta l_{100} = \frac{l_i - l_0}{l_0} \times 100 \quad (4)$$

where

- l_0 is the initial length;
- l_i is the length after immersion.

Similarly, calculate the percentage changes in width and thickness.

Report the results as the median values for the three test pieces. The change in surface area can be calculated from the values obtained for the length and the width.

8.5 Change in surface area

Measure the initial lengths of the diagonals of each test piece to the nearest 0,01 mm at the standard laboratory temperature.

After immersion, re-measure the lengths of the diagonals as described above. If an optical measuring system is used, this may be done in a suitable glass container without removing the test pieces from the test liquid.

Calculate the percentage change in area ΔA_{100} using Formula (5):

$$\Delta A_{100} = \left(\frac{l_A l_B}{l_a l_b} - 1 \right) \times 100 \quad (5)$$

where

- l_a and l_b are the lengths of the diagonals before immersion;
- l_A and l_B are the lengths of the diagonals after immersion.

If required, the percentage volume change ΔV_{100} may be calculated using Formula (6):

$$\Delta V_{100} = \left[\left(\frac{l_A l_B}{l_a l_b} \right)^{3/2} - 1 \right] \times 100 \quad (6)$$

The equation for percentage volume change assumes isotropic swelling. If any doubt exists, determine the percentage volume change as specified in 8.3, which is the preferred method.

Report the result as the median value for the three test pieces.

8.6 Change in hardness

Measure the IRHD hardness using the microtest described in ISO 48 on each test piece before and after immersion.

As an alternative, the normal IRHD hardness may be used with three plied-up test pieces, but in this case express the result as the apparent hardness.

Calculate the change in IRHD hardness ΔH , before and after immersion, using Formula (7):

$$\Delta H = H_i - H_0 \quad (7)$$

where

H_0 is the initial hardness;

H_i is the hardness after immersion.

Report the result as the median value for the three test pieces.

Alternatively, the method specified in ISO 7619-1 may be used.

8.7 Change in tensile stress-strain properties

Measure tensile stress-strain properties before and after immersion in accordance with ISO 37.

Calculate the selected tensile properties using the initial cross-section of the test piece for stress calculations. Calculate the change in the property ΔX_{100} as a percentage of the value for un-immersed material using Formula (8):

$$\Delta X_{100} = \frac{X_i - X_0}{X_0} \times 100 \quad (8)$$

where

X_0 is the initial value of the property;

X_i is the value of the property after immersion.

Report the result as the median value for the three test pieces.

8.8 Testing with liquid on one surface only

This test is applicable to relatively thin sheet materials, for example rubber diaphragms, which are exposed to liquid on one surface only during use.

Measure the nominal thickness of the test piece and then weigh it in air to the nearest milligram (mass m_0).

Then place the test piece in the apparatus as indicated in [Figure 1](#). Fill the chamber of the apparatus with the test liquid to a depth of approximately 15 mm and insert the plug (F). Maintain the apparatus at the required temperature for the duration of the test.

At the end of the contact period, bring the apparatus, if necessary, to the standard laboratory temperature.

Remove the liquid and release the test piece. Remove any surplus liquid from the surface of the test piece by wiping with filter paper or a lint-free fabric. Then weigh the test piece to the nearest milligram (mass m_i) and measure the thickness at the standard laboratory temperature.

If the test liquid is volatile at room temperature, make the measurement within 2 min following removal from the liquid.

Express the change in mass per unit surface area Δm_A , in grams per square metre, using Formula (9):

$$\Delta m_A = \frac{m_i - m_0}{A} \quad (9)$$

where

- m_0 is the initial mass, in grams, of the test piece;
- m_i is the final mass, in grams, of the test piece;
- A is the area, in square metres, of the circular surface of the test piece in contact with the test liquid.

Report the result as the median for the three test pieces.

Calculate the change in thickness as specified in [8.4](#).

8.9 Determination of extractable matter

8.9.1 General

If the test liquid is readily volatile, the amount of matter which it extracts from the test piece can be determined

- a) either by drying the treated test piece and comparing its mass with the mass before immersion;
- b) or by evaporating the test liquid to dryness and weighing the non-volatile residue.

Both methods are susceptible to error. In the method in which the dried test piece is weighed, the material can be oxidized if air is present during immersion, especially at high temperatures. In the method in which the test liquid is evaporated, there can be some loss of volatile extracted matter, especially plasticizers. Both methods are described in this International Standard and the choice between them depends on the nature of the material and the conditions of test.

It is difficult to define precisely what is meant by a “readily volatile” liquid, but it is suggested that the procedures described are not suitable for liquids less volatile than standard liquids A, B, C, D and E in [Annex A](#), i.e. for liquids boiling at above 110 °C.

The determination of extractable matter shall be made after having determined the change in mass (see [8.2](#)), the change in volume (see [8.3](#)) and the change in dimensions (see [8.4](#)).

Report the result as the median for the three test pieces.

8.9.2 By weighing the dried test piece

Dry the test piece, after immersion, under an absolute air pressure of approximately 20 kPa at approximately 40 °C to constant mass, i.e. until the difference between successive weighings at 30 min intervals does not exceed 1 mg.

The extractable-matter content is taken as the difference between the original mass of the test piece and its mass after immersion and drying, expressed as a percentage of the original mass of the test piece.

8.9.3 By evaporating the test liquid

Transfer the liquid in which the test piece was immersed to a suitable container and wash the test piece with 25 ml of fresh liquid, collecting the washings in the same container. Evaporate the liquid and dry the residue to constant mass under an absolute air pressure of approximately 20 kPa at approximately 40 °C.

Carry out a blank test to estimate the solids content in a volume of the test liquid equal to that used for the immersion plus that used for washing.

The extractable-matter content is taken as the mass of the dried residue, corrected for the result of the blank test, expressed as a percentage of the original mass of the test piece.

9 Precision

Precision results of an interlaboratory test programme (ITP) are given in [Annex C](#).

10 Test report

The test report shall include the following information:

- a) sample details:
 - 1) a full description of the sample and its origin,
 - 2) the method of preparation of test pieces from the sample, for example whether moulded or cut;
- b) a reference to this International Standard;
- c) test method and test details:
 - 1) the method(s) used,
 - 2) the type(s) of test piece used (dimensions),
 - 3) the standard laboratory temperature used,
 - 4) details of conditioning,
 - 5) the period and temperature of immersion,
 - 6) any deviation from the specified procedure;
- d) test results:
 - 1) the results, expressed in the form stated in the relevant subclause,
 - 2) the appearance of the test piece (for example cracking, delamination), if appropriate,
 - 3) the appearance of the test liquid (for example discoloration, sedimentation), if appropriate;
- e) the date of the test.

Annex A (normative)

Reference liquids

WARNING — Appropriate safety precautions should be taken when preparing and handling test liquids, especially those known to be toxic, corrosive or flammable. Products giving off fumes should be handled only under an efficiently ventilated hood, corrosive products should not be allowed to come into contact with the skin or ordinary clothing, and flammable products should be kept away from any source of ignition.

A.1 Standard simulated fuels

Commercial fuels vary widely in composition even within the same grade (i.e. knock-rating) and from the same source. There are hydrocarbon-based fuels with and without oxygen compounds as well as alcohol-based fuels. The grade of gasoline is improved by adding aromatic or oxygen-containing compounds, but these additives increase the effect of fuels on normally fuel-resistant rubbers. The composition varies with the situation on the gasoline market and with the geographical area and can change rapidly. Hence, several test liquids which are used in practice are recommended in [Tables A.1](#) and [A.2](#) to cover the range of different compositions. They can also serve as guidelines for the formulation of other suitable test liquids. Analytical reagent quality materials shall be used in making up the test liquids. Test liquids containing alcohol shall not be used if the fuels involved are known to be free of alcohol.

Table A.1 — Standard simulated fuels without oxygen compounds

Liquid	Constituents	CAS Registry Number	Content % (by volume)
A	2,2,4-Trimethylpentane	540-84-1	100
B	2,2,4-Trimethylpentane Toluene	540-84-1 108-88-3	70 30
C	2,2,4-Trimethylpentane Toluene	540-84-1 108-88-3	50 50
D	2,2,4-Trimethylpentane Toluene	540-84-1 108-88-3	60 40
E	Toluene	108-88-3	100
F	Straight-chain paraffins (C ₁₂ to C ₁₈) 1-Methylnaphthalene	68476-34-6 90-12-0	80 20

NOTE Liquids B, C and D simulate petroleum-derived fuels without oxygen compounds. Liquid F is intended to simulate diesel fuel, domestic heating oils and similar light furnace oils.

Table A.2 — Standard simulated fuels containing oxygen compounds (alcohols)

Liquid	Constituents	CAS Registry Number	Content % (by volume)
1	2,2,4-Trimethylpentane	540-84-1	30
	Toluene	108-88-3	50
	Di-isobutylene	25167-70-8	15
	Ethanol	64-17-5	5
2	2,2,4-Trimethylpentane	540-84-1	25,35 ^a
	Toluene	108-88-3	42,25 ^a
	Di-isobutylene	25167-70-8	12,68 ^a
	Ethanol	64-17-5	4,22 ^a
	Methanol	67-56-1	15,00
	Water	7732-18-5	0,50
3	2,2,4-Trimethylpentane	540-84-1	45
	Toluene	108-88-3	45
	Ethanol	64-17-5	7
	Methanol	67-56-1	3
4	2,2,4-Trimethylpentane	540-84-1	42,5
	Toluene	108-88-3	42,5
	Methanol	67-56-1	15

^a Together, these four constituents are equivalent to 84,5 % (by volume) of liquid 1 above.

A.2 Reference oils

A.2.1 General descriptions

Oil No. 1 (IRM 901) is a “low volume increase” oil, oil No. 2 (IRM 902) is a “medium volume increase” oil and oil No. 3 (IRM 903) is a “high volume increase” oil.

These reference oils are representative of low-additive mineral oils.

A.2.2 Requirements

The oils shall have the properties specified in ASTM D5964 and shown in [Table A.3](#). The properties given in [Table A.4](#) are typical of the oils but cannot be guaranteed by suppliers.

When these reference oils are required as test liquids, only those obtained from recognized suppliers shall be used for referee purposes and they shall be available for general use. However, in the event that they are not available, alternative oils may be used, but for routine testing only, provided that they comply with the requirements of [Table A.3](#) and also have been shown to give results similar to those obtained with the reference oils when testing rubbers of the same type of composition as those on which the routine tests are to be carried out.

Table A.3 — Specifications of reference oils

Property	Requirements		
	Oil No. 1	Oil No. 2	Oil No. 3
Aniline point, °C	124 ± 1	93 ± 3	70 ± 1
Kinematic viscosity, m ² /s (× 10 ⁻⁶)	18,12 to 20,34 ^a	19,2 to 21,5 ^a	31,9 to 34,1 ^b
Flash point, °C, min.	243	232	163
API gravity at 16 °C	27,8 to 29,8	19,0 to 21,0	21,0 to 23,0
Viscosity-gravity constant	0,790 to 0,805	0,860 to 0,870	0,875 to 0,885
Naphthenics content, c _N , %	27 (average)	35, min.	40, min.
Paraffinics content, c _P , %	65, min.	50, max.	45, max.
^a Measured at 99 °C.			
^b Measured at 37,8 °C.			

Table A.4 — Typical properties of reference oils

Property	Requirements		
	Oil No. 1	Oil No. 2	Oil No. 3
Pour point, °C	-12	-12	-31
ASTM colour	L3.5	L2.5	L0.5
Refractive index at 20 °C	1,484 8	1,510 5	1,502 6
UV absorbance at 260 nm	0,8	4,0	2,2
Aromatics content, c _A , %	3	12	14

A.3 Simulated service liquid

NOTE Liquid 102 has been removed from the present edition of this International Standard because no supplier can be found. For information, the composition of the liquid is given below.

Liquid 102 is intended to simulate certain high pressure hydraulic oils. It is a blend comprising 95 % (by mass) of oil No. 1 and 5 % (by mass) of a hydrocarbon-compound oil additive containing 29,5 % (by mass) to 33 % (by mass) of sulfur, 1,5 % to 2 % (by mass) of phosphorus and 0,7 % (by mass) of nitrogen.

A.3.1 Liquid 101

Liquid 101 is intended to simulate synthetic diester-type lubricating oils. It is a blend comprising 99,5 % (by mass) of di 2 ethylhexyl sebacate (CAS Registry Number: 122-62-3) and 0,5 % (by mass) of phenothiazine (CAS Registry Number: 92-84-2).

A.3.2 Liquid 103

Liquid 103 is intended to simulate phosphate-ester hydraulic oils used in aircraft. It is tri-*n*-butyl phosphate (CAS Registry Number: 126-73-8).

A.4 Chemical reagents

Tests with chemical reagents shall be carried out using the same chemicals at the same concentrations as those to be encountered in the intended use of the product. For general purposes, where no specification is known, the list of chemical reagents given in ISO 175 can be useful.

Annex B (normative)

Calibration schedule

B.1 Inspection

Before any calibration is undertaken, the condition of the items to be calibrated shall be ascertained by inspection and recorded in any calibration report or certificate. It shall be reported whether calibration is carried out in the “as-received” condition or after rectification of any abnormality or fault.

It shall be ascertained that the apparatus is generally fit for the intended purpose, including any parameters specified as approximate and for which the apparatus does not therefore need to be formally calibrated. If such parameters are liable to change, then the need for periodic checks shall be written into the detailed calibration procedures.

B.2 Schedule

Verification/calibration of the test apparatus is a mandatory part of this International Standard. However, the frequency of calibration and the procedures used are, unless otherwise stated, at the discretion of the individual laboratory, using ISO 18899:2013 for guidance.

The calibration schedule given in [Table B.1](#) has been compiled by listing all of the parameters specified in the test method, together with the specified requirement. A parameter and requirement can relate to the main test apparatus, to part of that apparatus or to an ancillary apparatus necessary for the test.

For each parameter, a calibration procedure is indicated by reference to ISO 18899:2013, to another publication or to a procedure particular to the test method which is detailed (whenever a calibration procedure which is more specific or detailed than that in ISO 18899:2013 is available, it shall be used in preference).

The verification frequency for each parameter is given by a code-letter. The code-letters used in the calibration schedule are:

- R use of certified reference material;
- C requirement to be confirmed, but no measurement;
- N initial verification only;
- S standard interval as given in ISO 18899:2013;
- U in use.

Table B.1 — Calibration frequency schedule

Parameter	Requirement(s)	Subclause in ISO 18899:2013	Verification frequency guide	Notes
Total immersion apparatus	Volume such that test pieces remain completely immersed and all surfaces are exposed to liquid	15.8, 19.1	U	
	Volume of liquid at least 15 times that of test pieces	15.8, 19.1	U	
	Inert to test liquid and rubber	15.8, 19.1	U	
	Stoppered bottle or tube to be used	19.1	U	For tests at temperatures considerably below boiling point of liquid
	Bottle or tube to be fitted with reflux condenser or equivalent	19.1	U	For tests at temperatures near boiling point of liquid
Apparatus for testing one surface only	As shown in Figure 1	-	N	
Balance	Accurate to 1 mg	22.1	S	
Dial gauge	See ISO 23529:2010, method A	15.1, 16.6	S	
Instrument for measuring length and width	Scale graduated in divisions of 0,01 mm	15.1	S	Preferably non-contacting
Instrument for measuring change in surface area	Scale graduated in divisions of 0,01 mm	15.3	S	Preferably non-contacting
Test liquid	As specified in Annex A	-	N	
Materials distilled water lintless blotting medium	To be used in 8.3	-	U	

In addition to the items listed in [Table B.1](#), use of the following is implied, all of which need calibrating in accordance with ISO 18899:2013:

- a timer;
- a thermometer for monitoring the conditioning and test temperatures;
- a hygrometer for monitoring the conditioning and test humidities;
- apparatus for measuring selected physical properties.

Annex C (informative)

Precision results from an interlaboratory test programme

C.1 General

The following interlaboratory test programme (ITP) was initially carried out in 2011.

All calculations to provide repeatability and reproducibility values were performed in accordance with ISO/TR 9272^[1]. Precision concepts and nomenclature are also given in ISO/TR 9272.

C.2 Precision results from the ITP

C.2.1 Programme details

The ITP was organized and conducted by Bundesanstalt für Materialforschung (Germany) in 2011. Cured test pieces were prepared in one laboratory and sent to all 12 participating laboratories.

A total of four compounds were used in the test. The samples were designated as Compounds A, B, C and D. For the details of the compounding of the materials and their vulcanization, see [Table C.1](#).

Table C.1 — Compounding

Ingredient	Number of parts by mass			
	Compound A	Compound B ⁱ	Compound C ^j	Compound D ^k
NR (TSR L)	100			
NBR (ACN content 28 %)		100		
HNBR (ACN content 39 %)			100	
FKM (VDF/HDF copolymer)				100
HAF carbon black (N 330)	30			
HAF carbon black (N 550)		65	50	
HAF carbon black (N 990)				25
Zinc oxide	3	5	2	
Magnesium oxide			2	3

^a N'-Isopropyl-N'-phenyl-p-phenyldiamine

^b Polymerized 2,2,4-trimethyl-1,2-dihydroquinoline

^c Benzothiazyl disulfide

^d Tetramethylthiuram disulfide

^e N-Cyclohexylbenzothiazyl-2-sulfenamide

^f organic phosphonium salt, e.g. triphenylbenzyl-phosphonium chloride

^g 1,3-bis(*t*-butylperoxyisopropyl)-benzene

^h 2,2-bis(4-hydroxyphenyl)-hexafluoropropane

ⁱ Compound B is in conformance with ISO 13226^[2] SRE-NBR 28/SX

^j Compound C is in conformance with ISO 13226^[2] SRE-HNBR/1X

^k Compound D is in conformance with ISO 13226^[2] SRE-FKM/2X

Table C.1 (continued)

Ingredient	Number of parts by mass			
	Compound A	Compound B ⁱ	Compound C ^j	Compound D ^k
Calcium hydroxide				2
Stearic acid		1		
Antioxidant (IPPD) ^a	1			
Antioxidant (TMQ) ^b		2		
Antioxidant Diphenylamine, styrenated			1	
Accelerator (MBTS) ^c	1,7			
Accelerator (TMTD) ^d		2,5		
Accelerator (CBS) ^e		1,5		
Accelerator ^f				0,44
Triallyl isocyanurate			1,5	
Sulfur	2,5	0,2		
Peroxide (40 % by mass) ^g			7,5	
Bisphenol ^h				1,35
Total	138,2	177,2	164,0	131,79
Press cure	150°C	160 °C	180°C	180°C + 220 °C
	18 min	20 min	10 min	7 min + 16 h
^a N'-Isopropyl-N'-phenyl-p-phenylendiamine ^b Polymerized 2,2,4-trimethyl-1,2-dihydroquinoline ^c Benzothiazyl disulfide ^d Tetramethylthiuram disulfide ^e N-Cyclohexylbenzothiazyl-2-sulfenamide ^f organic phosphonium salt, e.g. triphenylbenzyl-phosphonium chloride ^g 1,3-bis(<i>t</i> -butylperoxyisopropyl)-benzene ^h 2,2-bis(4-hydroxyphenyl)-hexafluoropropane ⁱ Compound B is in conformance with ISO 13226[2] SRE-NBR 28/SX ^j Compound C is in conformance with ISO 13226[2] SRE-HNBR/1X ^k Compound D is in conformance with ISO 13226[2] SRE-FKM/2X				

The influence of liquids during storage was determined for the following properties:

- change in mass
- change in volume
- change in dimensions
- change in hardness
- change in tensile stress-strain properties.

The test pieces were provided as disks with a diameter of 36,6 mm and type 2 dumb-bells.

The test pieces were stored in the liquids at standard laboratory temperature and also at 70 °C; the details of the storage are given in [Table C.2](#). Each participating laboratory used its own test liquids.

Table C.2 — Overview of the test program

Compound	Temperature	Duration of exposure	Liquid ^a	Method
A	standard laboratory	2 h + 6 h	B	mass
A	standard laboratory	24 h	B	mass; thickness; hardness
B	standard laboratory	2 h + 6 h	B	mass
B	standard laboratory	24 h	B	mass; volume; thickness; hardness
C	standard laboratory	24 h	B	mass; volume; tensile test
D	standard laboratory	24 h	E	mass; volume; tensile test
C	70 °C	7 d	Oil No. 3	mass; volume; hardness; tensile test
^a See Annex A .				

The number of laboratories on which precision data for each property is based is given in the tables of precision results ([Tables C.3 to C.15](#)). The number of participating laboratories as noted in these tables is the final number after identifying certain laboratory values as outliers (for each of the five properties).

The ITP testing was conducted over a period of four sequential weeks. On a specified day in each of these four weeks, five individual measurements were performed on all four materials. The test result of each week is the median of the five individual measurements. All analysis was conducted on the basis of these test results.

The participating laboratories were encouraged to use two equally competent operators (if available) for this ITP: Operator 1 for test weeks 1 and 2 and Operator 2 for test weeks 3 and 4. The aim of the use of different test pieces and different operators and the repetition over four test weeks was to include such normal variation sources in the final or pooled combined database. Thus, the precision values represent more reliable and realistic values compared to the usual ITP results which constitute a “single point in time” estimate of precision.

C.2.2 Precision results

The precision results are listed in [Tables C.3 to C.15](#).

The precision results as determined by this ITP should not be applied to acceptance or rejection testing for any group of materials or products without documentation that the results of this precision evaluation actually apply to the products or materials tested.

Explanation of symbols for [Tables C.3, C.4, C.5, C.6, C.7, C.8, C.9, C.10, C.11, C.12, C.13, C.14](#) and [C.15](#):

s_r = within-laboratory standard deviation (in measurement units);

r = repeatability (in measurement units);

(r) = repeatability (in percent of mean level);

s_R = between-laboratory standard deviation (for total between-laboratory variation in measurement units);

R = reproducibility (in measurement units);

(R) = reproducibility (in percent of mean level).

Table C.3 — Precision data for change in mass

Compound	Mean level	s_r	r	(r)	s_R	R	(R)	No. of laboratories ^a
A	120,53	2,78	7,77	6,45	3,81	10,68	8,86	9
B	10,31	0,76	2,13	20,65	0,86	2,40	23,32	9
Average ^b		1,77	4,95	13,55	2,34	6,54	16,09	

NOTE Duration of exposure: 2 h; standard laboratory temperature; Liquid B.

^a Number of laboratories after outliers deleted (total number of laboratories in ITP: 12).

^b Simple averages calculated.

Table C.4 — Precision data for change in mass

Compound	Mean level	s_r	r	(r)	s_R	R	(R)	No. of laboratories ^a
A	157,31	1,91	5,35	3,40	3,19	8,92	5,67	10
B	18,77	0,99	2,77	14,74	1,02	2,87	15,27	8
Average ^b		1,45	4,06	9,07	2,10	5,89	10,47	

NOTE Duration of exposure: 6 h; standard laboratory temperature; Liquid B.

^a Number of laboratories after outliers deleted (total number of laboratories in ITP: 12).

^b Simple averages calculated.

Table C.5 — Precision data for change in mass

Compound	Mean level	s_r	r	(r)	s_R	R	(R)	No. of laboratories ^a
A	160,93	1,63	4,55	2,83	2,76	7,73	4,80	10
B	27,17	0,78	2,20	8,09	1,69	4,74	17,44	9
C	21,55	1,12	3,15	14,61	1,74	4,86	22,55	10
D	3,26	0,09	0,24	7,47	0,39	1,10	33,64	9
Average ^b		0,92	2,57	8,40	1,43	4,00	17,41	

NOTE Duration of exposure: 24 h; standard laboratory temperature; Liquid B – Compound A, B, C; Liquid E – Compound D.

^a Number of laboratories after outliers deleted (total number of laboratories in ITP: 12).

^b Simple averages calculated.

Table C.6 — Precision data for change in mass

Compound	Mean level	s_r	r	(r)	s_R	R	(R)	No. of laboratories ^a
C	5,99	0,12	0,35	5,84	0,72	2,01	33,64	9

NOTE Duration of exposure: 7days; 70 °C; Oil No. 3.

^a Number of laboratories after outliers deleted (total number of laboratories in ITP: 12).

Table C.7 — Precision data for change in volume

Compound	Mean level	s_r	r	(r)	s_R	R	(R)	No. of laboratories ^a
B	40,37	1,24	3,47	8,61	1,27	3,57	8,84	8
C	30,37	2,19	6,14	20,20	2,73	7,64	25,16	9
D	7,39	0,43	1,21	16,42	0,95	2,67	36,11	9
Average ^b		1,29	3,61	15,08	1,65	4,63	23,37	

NOTE Duration of exposure: 24 h; standard laboratory temperature; Liquid B – Compound B, C; Liquid E – Compound D.
^a Number of laboratories after outliers deleted (total number of laboratories in ITP: 12).
^b Simple averages calculated.

Table C.8 — Precision data for change in volume

Compound	Mean level	s_r	r	(r)	s_R	R	(R)	No. of laboratories ^a
C	7,31	0,24	0,66	9,03	1,20	3,35	45,89	8

NOTE Duration of exposure: 7days; 70 °C; Oil No. 3.
^a Number of laboratories after outliers deleted (total number of laboratories in ITP: 12).

Table C.9 — Precision data for change in dimensions (thickness)

Compound	Mean level	s_r	r	(r)	s_R	R	(R)	No. of laboratories ^a
A	54,46	0,86	2,40	4,40	2,00	5,59	10,26	7
B	14,08	0,52	1,46	10,35	0,71	2,00	14,17	8
Average ^b		0,69	1,93	7,38	1,35	3,79	12,22	

NOTE Duration of exposure: 24 h; standard laboratory temperature; Liquid B.
^a Number of laboratories after outliers deleted (total number of laboratories in ITP: 12).
^b Simple averages calculated.

Table C.10 — Precision data for change in hardness

Compound	Mean level	s_r	r	(r)	s_R	R	(R)	No. of laboratories ^a
A	-21,93	0,55	1,53	6,98	2,35	6,57	29,98	9
B	-18,40	0,24	0,67	3,63	0,64	1,78	9,70	7
Average ^b		0,39	1,10	5,31	1,49	4,18	19,84	

NOTE Duration of exposure: 24 h; standard laboratory temperature; Liquid B.
^a Number of laboratories after outliers deleted (total number of laboratories in ITP: 12).
^b Simple averages calculated.

Table C.11 — Precision data for change in hardness

Compound	Mean level	s_r	r	(r)	s_R	R	(R)	No. of laboratories ^a
C	-3,68	0,93	2,60	70,63	1,36	3,80	103,06	10

NOTE Duration of exposure: 7days; 70 °C; Oil No. 3.
^a Number of laboratories after outliers deleted (total number of laboratories in ITP: 12).

Table C.12 — Precision data for change in tensile stress-strain properties — Tensile strength

Compound	Mean level	s_r	r	(r)	s_R	R	(R)	No. of laboratories ^a
C	-43,77	1,94	5,43	12,40	4,16	11,65	26,62	10
D	-17,88	1,46	4,09	22,87	3,53	9,89	55,34	10
Average ^b		1,70	4,76	17,63	3,85	10,77	40,98	

NOTE Duration of exposure: 24 h; standard laboratory temperature; Liquid B – Compound C; Liquid E – Compound D.
^a Number of laboratories after outliers deleted (total number of laboratories in ITP: 12).
^b Simple averages calculated.

Table C.13 — Precision data for change in tensile stress-strain properties — Tensile strength

Compound	Mean level	s_r	r	(r)	s_R	R	(R)	No. of laboratories ^a
C	-1,39	2,83	7,91	570,92	3,50	9,79	706,39	9

NOTE Duration of exposure: 7days; 70 °C; Oil No. 3.
^a Number of laboratories after outliers deleted (total number of laboratories in ITP: 12).

Table C.14 — Precision data for change in tensile stress-strain properties — Elongation

Compound	Mean level	s_r	r	(r)	s_R	R	(R)	No. of laboratories ^a
C	-42,68	3,05	8,55	20,03	3,93	11,01	25,80	10
D	-7,88	1,95	5,45	69,18	2,21	6,19	78,57	10
Average ^b		2,50	7,00	44,61	3,07	8,60	52,18	

NOTE Duration of exposure: 24 h; standard laboratory temperature; Liquid B – Compound C; Liquid E – Compound D.
^a Number of laboratories after outliers deleted (total number of laboratories in ITP: 12).
^b Simple averages calculated.

Table C.15 — Precision data for change in tensile stress-strain properties — Elongation

Compound	Mean level	s_r	r	(r)	s_R	R	(R)	No. of laboratories ^a
C	-2,38	3,91	10,93	458,52	4,70	13,17	552,21	8

NOTE Duration of exposure: 7days; 70 °C; Oil No. 3.
^a Number of laboratories after outliers deleted (total number of laboratories in ITP: 12).

Bibliography

- [1] ISO/TR 9272, *Rubber and rubber products — Determination of precision for test method standards*
- [2] ISO 13226, *Rubber — Standard reference elastomers (SREs) for characterizing the effect of liquids on vulcanized rubbers*

British Standards Institution (BSI)

BSI is the national body responsible for preparing British Standards and other standards-related publications, information and services.

BSI is incorporated by Royal Charter. British Standards and other standardization products are published by BSI Standards Limited.

About us

We bring together business, industry, government, consumers, innovators and others to shape their combined experience and expertise into standards-based solutions.

The knowledge embodied in our standards has been carefully assembled in a dependable format and refined through our open consultation process. Organizations of all sizes and across all sectors choose standards to help them achieve their goals.

Information on standards

We can provide you with the knowledge that your organization needs to succeed. Find out more about British Standards by visiting our website at bsigroup.com/standards or contacting our Customer Services team or Knowledge Centre.

Buying standards

You can buy and download PDF versions of BSI publications, including British and adopted European and international standards, through our website at bsigroup.com/shop, where hard copies can also be purchased.

If you need international and foreign standards from other Standards Development Organizations, hard copies can be ordered from our Customer Services team.

Subscriptions

Our range of subscription services are designed to make using standards easier for you. For further information on our subscription products go to bsigroup.com/subscriptions.

With **British Standards Online (BSOL)** you'll have instant access to over 55,000 British and adopted European and international standards from your desktop. It's available 24/7 and is refreshed daily so you'll always be up to date.

You can keep in touch with standards developments and receive substantial discounts on the purchase price of standards, both in single copy and subscription format, by becoming a **BSI Subscribing Member**.

PLUS is an updating service exclusive to BSI Subscribing Members. You will automatically receive the latest hard copy of your standards when they're revised or replaced.

To find out more about becoming a BSI Subscribing Member and the benefits of membership, please visit bsigroup.com/shop.

With a **Multi-User Network Licence (MUNL)** you are able to host standards publications on your intranet. Licences can cover as few or as many users as you wish. With updates supplied as soon as they're available, you can be sure your documentation is current. For further information, email bsmusales@bsigroup.com.

BSI Group Headquarters

389 Chiswick High Road London W4 4AL UK

Revisions

Our British Standards and other publications are updated by amendment or revision.

We continually improve the quality of our products and services to benefit your business. If you find an inaccuracy or ambiguity within a British Standard or other BSI publication please inform the Knowledge Centre.

Copyright

All the data, software and documentation set out in all British Standards and other BSI publications are the property of and copyrighted by BSI, or some person or entity that owns copyright in the information used (such as the international standardization bodies) and has formally licensed such information to BSI for commercial publication and use. Except as permitted under the Copyright, Designs and Patents Act 1988 no extract may be reproduced, stored in a retrieval system or transmitted in any form or by any means – electronic, photocopying, recording or otherwise – without prior written permission from BSI. Details and advice can be obtained from the Copyright & Licensing Department.

Useful Contacts:

Customer Services

Tel: +44 845 086 9001

Email (orders): orders@bsigroup.com

Email (enquiries): cservices@bsigroup.com

Subscriptions

Tel: +44 845 086 9001

Email: subscriptions@bsigroup.com

Knowledge Centre

Tel: +44 20 8996 7004

Email: knowledgecentre@bsigroup.com

Copyright & Licensing

Tel: +44 20 8996 7070

Email: copyright@bsigroup.com



...making excellence a habit.™