

# ISO miniature screw threads

ICS 21.040.30

## National foreword

This British Standard is the UK implementation of ISO 1501:2009.

The UK participation in its preparation was entrusted to Technical Committee FME/9, Fasteners.

A list of organizations represented on this committee can be obtained on request to its secretary.

This publication does not purport to include all the necessary provisions of a contract. Users are responsible for its correct application.

**Compliance with a British Standard cannot confer immunity from legal obligations.**

This British Standard was published under the authority of the Standards Policy and Strategy Committee on 31 July 2009

© BSI 2009

ISBN 978 0 580 62327 1

### Amendments/corrigenda issued since publication

Date	Comments

# INTERNATIONAL STANDARD

**ISO**  
**1501**

First edition  
2009-05-15

---

---

## ISO miniature screw threads

*Filetages miniatures ISO*



Reference number  
ISO 1501:2009(E)

**PDF disclaimer**

This PDF file may contain embedded typefaces. In accordance with Adobe's licensing policy, this file may be printed or viewed but shall not be edited unless the typefaces which are embedded are licensed to and installed on the computer performing the editing. In downloading this file, parties accept therein the responsibility of not infringing Adobe's licensing policy. The ISO Central Secretariat accepts no liability in this area.

Adobe is a trademark of Adobe Systems Incorporated.

Details of the software products used to create this PDF file can be found in the General Info relative to the file; the PDF-creation parameters were optimized for printing. Every care has been taken to ensure that the file is suitable for use by ISO member bodies. In the unlikely event that a problem relating to it is found, please inform the Central Secretariat at the address given below.



**COPYRIGHT PROTECTED DOCUMENT**

© ISO 2009

All rights reserved. Unless otherwise specified, no part of this publication may be reproduced or utilized in any form or by any means, electronic or mechanical, including photocopying and microfilm, without permission in writing from either ISO at the address below or ISO's member body in the country of the requester.

ISO copyright office  
Case postale 56 • CH-1211 Geneva 20  
Tel. + 41 22 749 01 11  
Fax + 41 22 749 09 47  
E-mail [copyright@iso.org](mailto:copyright@iso.org)  
Web [www.iso.org](http://www.iso.org)

Published in Switzerland

## Contents

Page

Foreword.....	iv
<b>1 Scope .....</b>	<b>1</b>
<b>2 Normative references .....</b>	<b>1</b>
<b>3 Terms and definitions.....</b>	<b>1</b>
<b>4 Symbols .....</b>	<b>1</b>
<b>5 Profiles .....</b>	<b>2</b>
<b>5.1 Basic profile .....</b>	<b>2</b>
<b>5.2 Design profile .....</b>	<b>3</b>
<b>6 Diameter-pitch combinations and basic dimensions .....</b>	<b>3</b>
<b>7 Tolerances .....</b>	<b>4</b>
<b>7.1 Tolerance position .....</b>	<b>4</b>
<b>7.2 Tolerance grades .....</b>	<b>4</b>
<b>7.3 Grade-position combinations and tolerance zones .....</b>	<b>5</b>
<b>8 Designation .....</b>	<b>8</b>
<b>9 Limits of size .....</b>	<b>8</b>
<b>10 Inspection .....</b>	<b>10</b>
<b>Annex A (normative) ISO miniature screw threads with nominal diameters from 1 mm to 1,4 mm .....</b>	<b>11</b>
<b>Annex B (informative) Inspection .....</b>	<b>14</b>
<b>Annex C (informative) Differences between the ISO International Standards and those of some countries concerning miniature screw threads.....</b>	<b>15</b>

## Foreword

ISO (the International Organization for Standardization) is a worldwide federation of national standards bodies (ISO member bodies). The work of preparing International Standards is normally carried out through ISO technical committees. Each member body interested in a subject for which a technical committee has been established has the right to be represented on that committee. International organizations, governmental and non-governmental, in liaison with ISO, also take part in the work. ISO collaborates closely with the International Electrotechnical Commission (IEC) on all matters of electrotechnical standardization.

International Standards are drafted in accordance with the rules given in the ISO/IEC Directives, Part 2.

The main task of technical committees is to prepare International Standards. Draft International Standards adopted by the technical committees are circulated to the member bodies for voting. Publication as an International Standard requires approval by at least 75 % of the member bodies casting a vote.

Attention is drawn to the possibility that some of the elements of this document may be the subject of patent rights. ISO shall not be held responsible for identifying any or all such patent rights.

ISO 1501 was prepared by Technical Committee ISO/TC 1, *Screw threads*.

This first edition of ISO 1501 is a technical revision of ISO/R 1501:1970, which was cancelled in 1998.

# ISO miniature screw threads

## 1 Scope

This International Standard specifies the profiles, diameter-pitch combinations, basic dimensions, tolerances, limits of size and designation for ISO miniature screw threads with nominal diameters from 0,3 mm to 1,4 mm. These threads are applicable to timepieces, optical instruments, electrical meters, measuring instruments, etc.

The profiles and tolerance system for ISO miniature screw threads (S) differ from the profile and tolerance system for ISO general purpose metric screw threads (M).

For threads with nominal diameters from 1 mm to 1,4 mm, designers shall decide to use ISO general purpose metric screw threads (M) or ISO miniature screw threads (S). ISO miniature screw threads are shown in Annex A.

Annex C illustrates the differences in miniature screw threads between the ISO International Standards and those of certain countries.

## 2 Normative references

The following referenced documents are indispensable for the application of this document. For dated references, only the edition cited applies. For undated references, the latest edition of the referenced document (including any amendments) applies.

ISO 5408:—<sup>1)</sup>, *Screw threads — Vocabulary*

## 3 Terms and definitions

For the purposes of this document, the terms and definitions given in ISO 5408 apply.

## 4 Symbols

The following symbols are used:

Symbol	Term
$D$	basic major diameter of internal thread; nominal diameter
$D_2$	basic pitch diameter of internal thread
$D_1$	basic minor diameter of internal thread
$d$	basic major diameter of external thread; nominal diameter

1) To be published. (Revision of ISO 5408:1983)

$d_2$	basic pitch diameter of external thread
$d_1$	basic minor diameter of external thread on basic profile
$d_3$	basic minor diameter of external thread on design profile
$P$	pitch
$H$	height of fundamental triangle
$H_1$	height of thread on basic profile; flank overlap
$h_3$	height of external thread on design profile
$a_c$	clearance between minor diameters on design profile
$EI$	lower deviations of internal thread on design profile
$es$	upper deviations of external thread on design profile
$T$	tolerances
$T_{D2}$	tolerances for $D_2$
$T_{D1}$	tolerances for $D_1$
$T_d$	tolerances for $d$
$T_{d2}$	tolerances for $d_2$
$T_{d3}$	tolerances for $d_3$

## 5 Profiles

### 5.1 Basic profile

The basic profile is shown as a thick line in Figure 1.

The dimensions of the basic profile are given in Table 1.

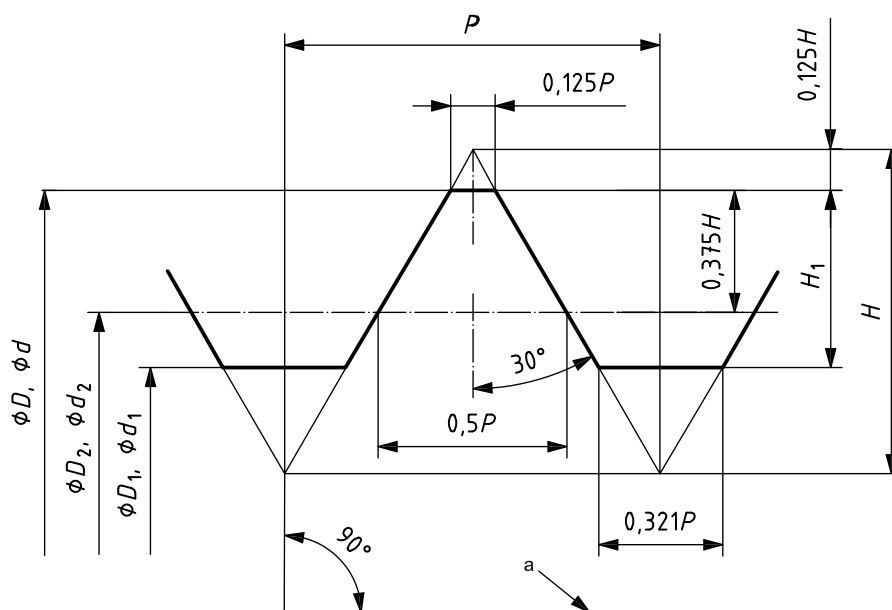

a Axis of screw thread.

**Figure 1 — Basic profile**



## 5.2 Design profile

The design profile is shown as a thick line in Figure 2.

The dimensions of the design profile are given in Table 1.

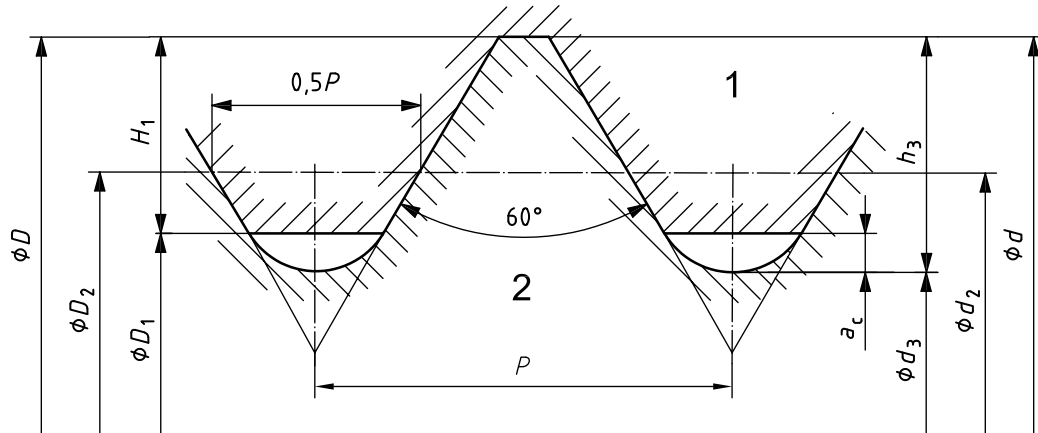

### Key

- 1 internal thread
- 2 external thread

Figure 2 — Design profile

Table 1 — Dimensions of profiles

Dimensions in millimetres

Pitch $P$	$H$ $0,866\ 025P$	$H_1$ $0,48P$	$0,375H$ $0,324\ 760P$	$h_3$ $0,56P$	$a_c$ $0,08P$
0,08	0,069 282	0,038 400	0,025 981	0,044 800	0,006
0,09	0,077 942	0,043 200	0,029 228	0,050 400	0,007
0,1	0,086 603	0,048 000	0,032 476	0,056 000	0,008
0,125	0,108 253	0,060 000	0,040 595	0,070 000	0,010
0,15	0,129 904	0,072 000	0,048 714	0,084 000	0,012
0,175	0,151 554	0,084 000	0,056 833	0,098 000	0,014
0,2	0,173 205	0,096 000	0,064 952	0,112 000	0,016
0,225	0,194 856	0,108 000	0,073 071	0,126 000	0,018
0,25	0,216 506	0,120 000	0,081 190	0,140 000	0,020
0,3	0,259 808	0,144 000	0,097 428	0,168 000	0,024

## 6 Diameter-pitch combinations and basic dimensions

The diameter-pitch combinations and basic dimensions are given in Table 2.

For threads with nominal diameters from 1 mm to 1,4 mm, diameter-pitch combinations and basic dimensions are given in Annex A.

Choose, preferably, diameters in column 1 of Table 2.

**Table 2 — Diameter-pitch combinations and basic dimensions**

Dimensions in millimetres

Nominal diameter <i>D, d</i>		Pitch <i>P</i>	Pitch diameter <i>D<sub>2</sub>, d<sub>2</sub></i>	Minor diameter	
First choice	Second choice			Internal thread <i>D<sub>1</sub></i>	External thread <i>d<sub>3</sub></i>
0,3		0,08	0,248	0,223	0,210
	0,35	0,09	0,292	0,264	0,249
0,4		0,1	0,335	0,304	0,288
	0,45	0,1	0,385	0,354	0,338
0,5		0,125	0,419	0,380	0,360
	0,55	0,125	0,469	0,430	0,410
0,6		0,15	0,503	0,456	0,432
	0,7	0,175	0,586	0,532	0,504
0,8		0,2	0,670	0,608	0,576
	0,9	0,225	0,754	0,684	0,648

NOTE See Annex A for threads with nominal diameters from 1 mm to 1,4 mm.

The basic dimensions given in Table 2 are calculated using Equations (1), (2) and (3):

$$D_2 = d_2 = d - 0,649\ 52P \quad (1)$$

$$D_1 = d - 0,96P \quad (2)$$

$$d_3 = d - 1,12P \quad (3)$$

NOTE The formula for  $d_3$  given in Equation (3) is based upon a root radius equal to  $0,2P$  approximately.

## 7 Tolerances

### 7.1 Tolerance position

The tolerance positions for diameters  $D$ ,  $D_2$ ,  $D_1$ ,  $d$ ,  $d_2$  and  $d_3$  are given in Table 3.

The fundamental deviations of diameters are given in Table 4.

### 7.2 Tolerance grades

The tolerance grades for diameters  $D_2$ ,  $D_1$ ,  $d$ ,  $d_2$  and  $d_3$  are given in Table 5.

The tolerances of diameters are given in Table 6.

There is no tolerance requirement for diameters  $D$ .

### 7.3 Grade-position combinations and tolerance zones

For internal threads, tolerance Grade 3 of pitch diameter shall be used for the tolerance position G and thread tolerance Grade 4 of pitch diameter shall be used for the tolerance position H.

For internal threads, there are four tolerance classes, 3G5, 3G6, 4H5 and 4H6. See Figure 3.

For external threads, there is only one tolerance class, 5h3. See Figure 4.

NOTE For the symbol designating tolerance class, see Clause 8.

**Table 3 — Tolerance positions**

Thread	Diameter	Position
Internal thread	Major diameter $D$	G, H
	Pitch diameter $D_2$	
	Minor diameter $D_1$	H
External thread	Major diameter $d$	h
	Pitch diameter $d_2$	
	Minor diameter $d_3$	
NOTE The tolerance positions of major diameter $D$ and pitch diameter $D_2$ for internal thread are always the same.		

**Table 4 — Fundamental deviations**

Deviations in micrometres

Pitch $P$ mm	Internal thread		External thread
	$D, D_2$	$D, D_2, D_1$	$d, d_2, d_3$
	G	H	h
	$EI$	$EI$	$es$
0,08	+6	0	0
0,09	+6	0	0
0,1	+6	0	0
0,125	+8	0	0
0,15	+8	0	0
0,175	+10	0	0
0,2	+10	0	0
0,225	+10	0	0
NOTE See Annex A for threads with nominal diameters from 1 mm to 1,4 mm.			

**Table 5 — Tolerance grades**

Thread	Diameter	Grade
Internal thread	Pitch diameter $D_2$	3, 4
	Minor diameter $D_1$	5, 6
External thread	Major diameter $d$	3
	Pitch diameter $d_2$	5
	Minor diameter $d_3$	4

NOTE Usually there is no requirement to check  $d_3$  for conformance.

**Table 6 — Tolerances**

Tolerances in micrometres

Pitch $P$ mm	Internal thread				External thread		
	$T_{D2}$		$T_{D1}$		$T_d$	$T_{d2}$	$T_{d3}$
	Grade 3	Grade 4	Grade 5	Grade 6	Grade 3	Grade 5	Grade 4
0,08	14	20	17	—	16	20	20
0,09	16	22	22	—	18	22	22
0,1	18	24	26	38	20	24	24
0,125	18	26	35	55	20	26	28
0,15	20	28	46	66	25	28	32
0,175	22	32	53	73	25	32	36
0,2	26	36	57	77	30	36	40
0,225	30	40	61	81	30	40	44

NOTE 1 See Annex A for threads with nominal diameters from 1 mm to 1,4 mm.  
 NOTE 2 Usually there is no requirement to check  $d_3$  for conformance.

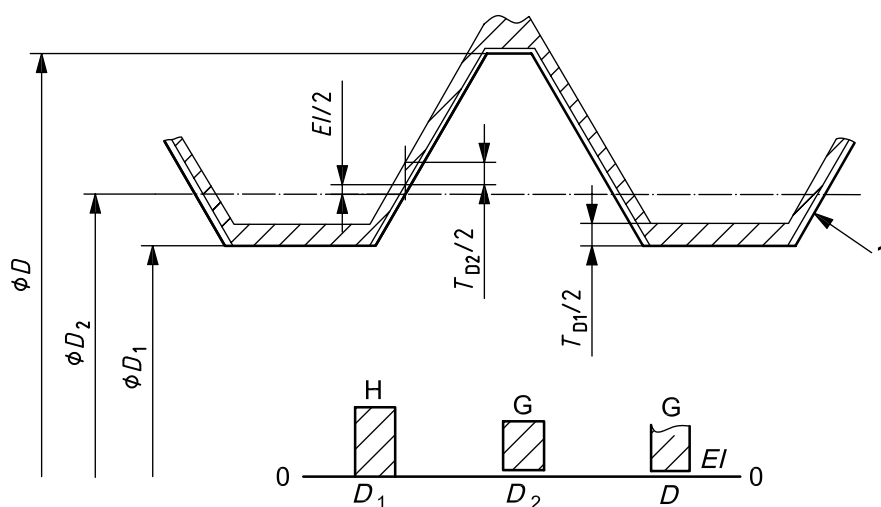

a) Tolerance class 3G5 and 3G6

**Figure 3 (continued)**

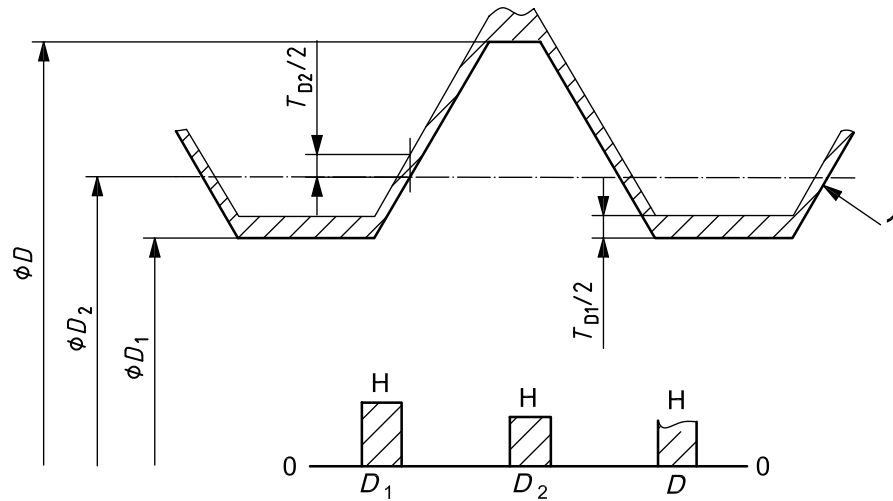

b) Tolerance class 4H5 and 4H6

**Key**

1 design profile

**Figure 3 — Tolerance zone of internal thread**

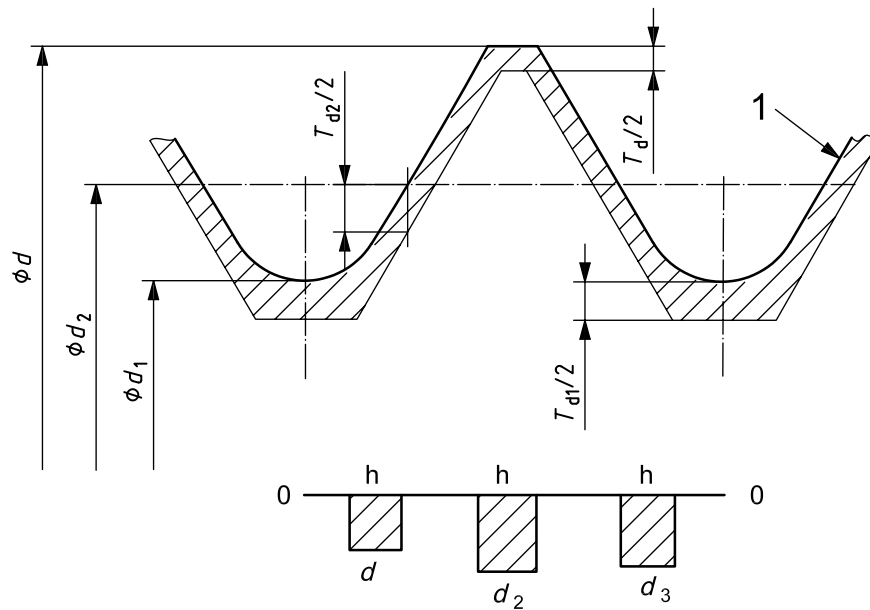

Tolerance class 5h3

**Key**

1 design profile

**Figure 4 — Tolerance zone of external thread**

## 8 Designation

The designation of a screw thread shall comprise the letter S and the value of the nominal diameter expressed in millimetres, followed by a dash and the symbol for the tolerance class.

The symbol for the tolerance class shall comprise:

- a figure indicating the tolerance grade of pitch diameter;
- a letter indicating the tolerance position of pitch diameter; capital letter for internal threads, lowercase letter for external threads;
- a figure indicating the tolerance grade of crest diameter, minor diameter of internal thread or major diameter of external thread.

A fit between threaded parts shall be indicated by the internal thread tolerance class symbol followed by the external thread tolerance class symbol, separated by a stroke.

When left-hand threads are specified, the letters LH shall be added to the thread designation, separated by a dash.

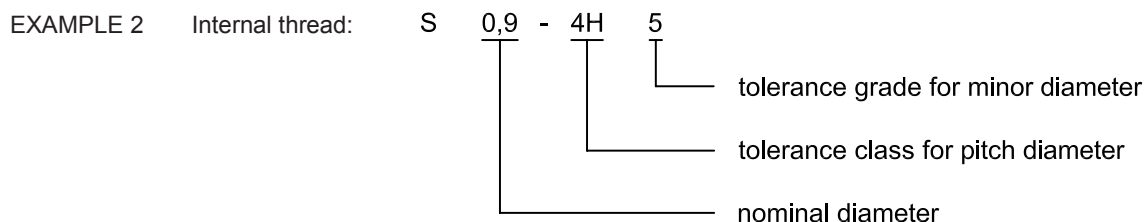
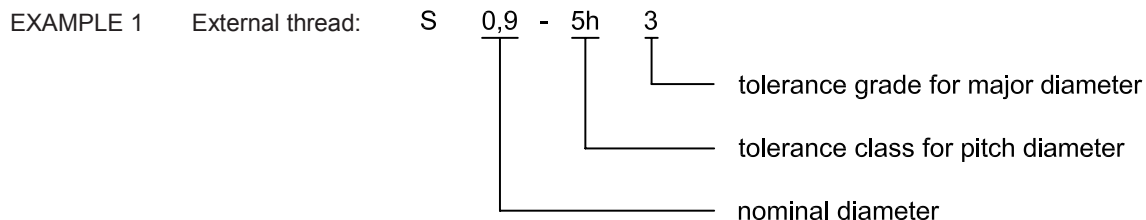

EXAMPLE 3 Fit between threaded parts: S 0,9 - 3G5/5h3

EXAMPLE 4 Left-hand thread: S 0,9 - 4H6 - LH

## 9 Limits of size

The limits of size for tolerance classes 3G5, 3G6, 4H5, 4H6 and 5h3 are given in Tables 7, 8 and 9.

Table 7 — Limits of size for tolerance classes 3G5 and 3G6

Dimensions in millimetres

Nominal diameter <i>D</i>	Pitch <i>P</i>	Major diameter <i>D</i>		3G		Grade 5		Grade 6	
				Pitch diameter <i>D</i> <sub>2</sub>		Minor diameter <i>D</i> <sub>1</sub>			
		max.	min.	max.	min.	max.	min.	max.	min.
0,3	0,08	not specified	0,306	0,268	0,254	0,240	0,223	—	—
0,35	0,09		0,356	0,314	0,298	0,286	0,264	—	—
0,4	0,1		0,406	0,359	0,341	0,330	0,304	0,342	0,304
0,45	0,1		0,456	0,409	0,391	0,380	0,354	0,392	0,354
0,5	0,125		0,508	0,445	0,427	0,415	0,380	0,435	0,380
0,55	0,125		0,558	0,495	0,477	0,465	0,430	0,485	0,430
0,6	0,15		0,608	0,531	0,511	0,502	0,456	0,522	0,456
0,7	0,175		0,710	0,618	0,596	0,585	0,532	0,605	0,532
0,8	0,2		0,810	0,706	0,680	0,665	0,608	0,685	0,608
0,9	0,225		0,910	0,794	0,764	0,745	0,684	0,765	0,684

NOTE See Annex A for threads with nominal diameters from 1 mm to 1,4 mm.

Table 8 — Limits of size for tolerance classes 4H5 and 4H6

Dimensions in millimetres

Nominal diameter <i>D</i>	Pitch <i>P</i>	Major diameter <i>D</i>		4H		Grade 5		Grade 6	
				Pitch diameter <i>D</i> <sub>2</sub>		Minor diameter <i>D</i> <sub>1</sub>			
		max.	min.	max.	min.	max.	min.	max.	min.
0,3	0,08	not specified	0,300	0,268	0,248	0,240	0,223	—	—
0,35	0,09		0,350	0,314	0,292	0,286	0,264	—	—
0,4	0,1		0,400	0,359	0,335	0,330	0,304	0,342	0,304
0,45	0,1		0,450	0,409	0,385	0,380	0,354	0,392	0,354
0,5	0,125		0,500	0,445	0,419	0,415	0,380	0,435	0,380
0,55	0,125		0,550	0,495	0,469	0,465	0,430	0,485	0,430
0,6	0,15		0,600	0,531	0,503	0,502	0,456	0,522	0,456
0,7	0,175		0,700	0,618	0,586	0,585	0,532	0,605	0,532
0,8	0,2		0,800	0,706	0,670	0,665	0,608	0,685	0,608
0,9	0,225		0,900	0,794	0,754	0,745	0,684	0,765	0,684

NOTE See Annex A for threads with nominal diameters from 1 mm to 1,4 mm.

**Table 9 — Limits of size for tolerance class 5h3**

Dimensions in millimetres

Nominal diameter <i>d</i>	Pitch <i>P</i>	Major diameter <i>d</i>		Pitch diameter <i>d</i> <sub>2</sub>		Minor diameter <i>d</i> <sub>3</sub>	
		max.	min.	max.	min.	max.	min.
0,3	0,08	0,300	0,284	0,248	0,228	0,210	0,190
0,35	0,09	0,350	0,332	0,292	0,270	0,249	0,227
0,4	0,1	0,400	0,380	0,335	0,311	0,288	0,264
0,45	0,1	0,450	0,430	0,385	0,361	0,338	0,314
0,5	0,125	0,500	0,480	0,419	0,393	0,360	0,332
0,55	0,125	0,550	0,530	0,469	0,443	0,410	0,382
0,6	0,15	0,600	0,575	0,503	0,475	0,432	0,400
0,7	0,175	0,700	0,675	0,586	0,554	0,504	0,468
0,8	0,2	0,800	0,770	0,670	0,634	0,576	0,536
0,9	0,225	0,900	0,870	0,754	0,714	0,648	0,604
NOTE 1	See Annex A for threads with nominal diameters from 1 mm to 1,4 mm.						
NOTE 2	Usually there is no requirement to check <i>d</i> <sub>3</sub> for conformance.						

## 10 Inspection

There are different ways to inspect miniature screw threads. Information on inspection is given in Annex B.



## Annex A (normative)

### ISO miniature screw threads with nominal diameters from 1 mm to 1,4 mm

#### A.1 Profiles

For the basic profile and design profile, see Clause 5.

#### A.2 Diameter-pitch combinations and basic dimensions

The diameter-pitch combinations and basic dimensions are given in Table A.1.

**Table A.1 — Diameter-pitch combinations and basic dimensions**

Dimensions in millimetres

Nominal diameter $D, d$		Pitch $P$	Pitch diameter $D_2, d_2$	Minor diameter	
First choice	Second choice			Internal thread $D_1$	External thread $d_3$
1		0,25	0,838	0,760	0,720
	1,1	0,25	0,938	0,860	0,820
1,2		0,25	1,038	0,960	0,920
	1,4	0,3	1,205	1,112	1,064

#### A.3 Tolerances

For the tolerance positions and grades, see Table 3 and Table 5, respectively.

For the grade-position combinations and tolerance zones, see 7.3.

The fundamental deviations of diameters are given in Table A.2.

The tolerances of diameters are given in Table A.3.

**Table A.2 — Fundamental deviations**

Deviations in micrometres

Pitch $P$ mm	Internal thread		External thread
	$D, D_2$	$D, D_2, D_1$	$d, d_2, d_3$
	G	H	h
	$EI$	$EI$	$es$
0,25	+12	0	0
0,3	+12	0	0

**Table A.3 — Tolerances**

Tolerances in micrometres

Pitch <i>P</i> mm	Internal thread				External thread		
	$T_{D2}$		$T_{D1}$		$T_d$	$T_{d2}$	$T_{d3}$
	Grade 3	Grade 4	Grade 5	Grade 6	Grade 3	Grade 5	Grade 4
0,25	32	44	65	85	35	44	48
0,3	38	50	73	93	40	50	56

NOTE Usually there is no requirement to check  $d_3$  for conformance.

## A.4 Designation

For the designation, see Clause 8.

## A.5 Limits of size

The limits of size for tolerance classes 3G5, 3G6, 4H5, 4H6 and 5h3 are given in Tables A.4, A.5 and A.6.

**Table A.4 — Limits of size for tolerance classes 3G5 and 3G6**

Dimensions in millimetres

Nominal diameter <i>D</i>	Pitch <i>P</i>	Major diameter <i>D</i>		3G		Grade 5		Grade 6	
				Pitch diameter $D_2$		Minor diameter $D_1$			
		max.	min.	max.	min.	max.	min.	max.	min.
1	0,25	not specified	1,012	0,882	0,850	0,825	0,760	0,845	0,760
1,1	0,25		1,112	0,982	0,950	0,925	0,860	0,945	0,860
1,2	0,25		1,212	1,082	1,050	1,025	0,960	1,045	0,960
1,4	0,3		1,412	1,255	1,217	1,185	1,112	1,205	1,112

**Table A.5 — Limits of size for tolerance classes 4H5 and 4H6**

Dimensions in millimetres

Nominal diameter <i>D</i>	Pitch <i>P</i>	Major diameter <i>D</i>		4H		Grade 5		Grade 6	
				Pitch diameter $D_2$		Minor diameter $D_1$			
		max.	min.	max.	min.	max.	min.	max.	min.
1	0,25	not specified	1,000	0,882	0,838	0,825	0,760	0,845	0,760
1,1	0,25		1,100	0,982	0,938	0,925	0,860	0,945	0,860
1,2	0,25		1,200	1,082	1,038	1,025	0,960	1,045	0,960
1,4	0,3		1,400	1,255	1,205	1,185	1,112	1,205	1,112

**Table A.6 — Limits of size for tolerance class 5h3**

Dimensions in millimetres

Nominal diameter <i>d</i>	Pitch <i>P</i>	Major diameter <i>d</i>		Pitch diameter <i>d</i> <sub>2</sub>		Minor diameter <i>d</i> <sub>3</sub>	
		max.	min.	max.	min.	max.	min.
1	0,25	1,000	0,965	0,838	0,794	0,720	0,672
1,1	0,25	1,100	1,065	0,938	0,894	0,820	0,772
1,2	0,25	1,200	1,165	1,038	0,994	0,920	0,872
1,4	0,3	1,400	1,360	1,205	1,155	1,064	1,008

NOTE Usually there is no requirement to check *d*<sub>3</sub> for conformance.

## Annex B (informative)

### Inspection

#### B.1 Pitch diameters and root diameters

The maximum material limit (MML) of the virtual pitch diameter and the root diameter with straight flank ( $D_{\min}$  or  $d_{1,\max}$ ) are checked by thread GO gauges.

The maximum size (for internal thread) or minimum size (for external thread) of pitch diameter is checked by thread NOT GO gauges.

External threads with diameter less than 1 mm are checked by thread GO ring gauges only.

The limits of size for  $d_3$  are mainly used for the design of the threading tool. Usually there is no requirement to check  $d_3$  for conformance.

Other checking methods can be used when an agreement has been reached between the thread manufacturer and purchaser, such as optical projection and wire thread measurement.

#### B.2 Crest diameters

Crest diameters should be checked by micrometers or plain gauges, GO and NOT GO.

## Annex C (informative)

### Differences between the ISO International Standards and those of some countries concerning miniature screw threads

Table C.1 illustrates the differences between the ISO International Standards and those of eight countries concerning miniature screw threads.

**Table C.1 — Differences between the ISO International Standards and those of eight countries concerning miniature screw threads**

Standard	Range of nominal diameter	Design profile $H_1, h_3$	Series $d-P$	Tolerance		Thread symbol
				Position	Grade	
ISO	0,3 mm to 1,4 mm.	$H_1 = 0,48P$ ; $h_3 = 0,56P$ .	Two series of diameters. 14 diameters.	Internal thread: G, H; External thread: h.	$D_2$ : 3, 4; $D_1$ : 5, 6; $d$ : 3; $d_2$ : 5; $d_3$ : 4.	S
NIHS	ISO	ISO. Add $D_4$ to replace $D$ .	One series. Delete 0,45, 0,55 and 1,1.	Internal thread: G; External thread: h.	$D_2$ : 3; $D_1$ : 5, 6; $d$ : 3; $d_2$ : 5; $d_3$ : 4.	S
GB	ISO	ISO	ISO	ISO	ISO. Add 5 for $d$ .	S
NF	ISO; 1 mm to 1,4 mm only for horology industry.	ISO	ISO	ISO	ISO	S
BS		ISO	ISO	ISO	ISO	S
JIS		ISO	ISO	ISO	ISO	ISO
DIN	0,3 mm to 0,9 mm.	ISO	Delete 0,45 and 0,55. Only one diameter in 2nd series.	ISO	ISO	M
GOST	0,25 mm to 0,9 mm.	ISO	Add 0,25 mm diameter.	ISO	ISO. Add 5 for $d$ .	M
ASME	ISO	$h_3 = 0,572 6P$ ; Add $D_4$ to replace $D$ .	ISO	Internal thread: H; External thread: h.	Different from ISO tolerance. Establish new tolerance formulae.	UNM

Table C.1 (continued)

Standard	Range of nominal diameter	Design profile $H_1, h_3$	Series $d-P$	Tolerance		Thread symbol
				Position	Grade	
NOTE 1	The standard numbers of miniature screw threads from eight countries are the following:					
	— NIHS 06-02, 05:1970 (Switzerland);					
	— GB/T 15054.1, GB/T 15054.2, GB/T 15054.3, GB/T 15054.4, GB/T 15054.5-1994 (China);					
	— NF E03-501:1970, NF E03-502:1970, NF E03-503:1970, NF E03-504:1970 (France);					
	— BS 4827:1972 (UK);					
	— JIS B0201:1973 (Japan);					
	— DIN 14-1:1987, DIN 14-2:1987, DIN 14-3:1987, DIN 14-4:1987 (Germany);					
	— GOST 8724:2002, GOST 9000:1981, GOST 3199:1984 (the Russian Federation);					
	— ASME B1.10M:2004 (USA).					
NOTE 2	The tolerance formulae of miniature threads from the USA are the following:					
	$T_{D4} = 0,168P + 0,008$	(Major diameter of internal thread);				
	$T_{D2} = 0,08P + 0,008$	(Pitch diameter of internal thread);				
		$(T_{D2} \text{ of USA} \leq T_{D2} \text{ of ISO Grade 3, the difference} \leq 6 \mu\text{m});$				
	$T_{D1} = 0,32P + 0,012$	(Minor diameter of internal thread);				
		$(T_{D1} \text{ of USA} \approx T_{D1} \text{ of ISO Grade 6, the difference} \leq 15 \mu\text{m});$				
	$T_d = 0,12P + 0,006$	(Major diameter of external thread);				
		$(T_d \text{ of USA} \approx T_d \text{ of ISO Grade 3, the difference} \leq 3 \mu\text{m});$				
	$T_{d2} = 0,08P + 0,008$	(Pitch diameter of external thread);				
		$(T_{d2} \text{ of USA} < T_{d2} \text{ of ISO Grade 5; the difference} \leq 18 \mu\text{m});$				
	$T_{d3} = 0,16P + 0,008$	(Minor diameter of external thread);				
		$(T_{d3} \text{ of USA} = T_{d3} \text{ of ISO Grade 4, except the one with pitch } 0,08, \text{ the difference is } 1 \mu\text{m}).$				
NOTE 3	Basic major diameter of internal thread: $D_4 = D + 0,007\ 217P$ (Root radius = $0,007\ 217P$ ).					

There are three main differences between the ISO International Standards and those of the eight other countries:

- five countries restrict the use of miniature screw threads with diameters from 1 mm to 1,4 mm;
- the tolerances of the USA are different from the tolerances of other countries;
- three countries do not use S as the symbol for miniature screw threads.









---

## BSI - British Standards Institution

BSI is the independent national body responsible for preparing British Standards. It presents the UK view on standards in Europe and at the international level. It is incorporated by Royal Charter.

### Revisions

British Standards are updated by amendment or revision. Users of British Standards should make sure that they possess the latest amendments or editions.

It is the constant aim of BSI to improve the quality of our products and services. We would be grateful if anyone finding an inaccuracy or ambiguity while using this British Standard would inform the Secretary of the technical committee responsible, the identity of which can be found on the inside front cover. Tel: +44 (0)20 8996 9000. Fax: +44 (0)20 8996 7400.

BSI offers members an individual updating service called PLUS which ensures that subscribers automatically receive the latest editions of standards.

### Buying standards

Orders for all BSI, international and foreign standards publications should be addressed to Customer Services. Tel: +44 (0)20 8996 9001. Fax: +44 (0)20 8996 7001 Email: [orders@bsigroup.com](mailto:orders@bsigroup.com) You may also buy directly using a debit/credit card from the BSI Shop on the Website <http://www.bsigroup.com/shop>

In response to orders for international standards, it is BSI policy to supply the BSI implementation of those that have been published as British Standards, unless otherwise requested.

### Information on standards

BSI provides a wide range of information on national, European and international standards through its Library and its Technical Help to Exporters Service. Various BSI electronic information services are also available which give details on all its products and services. Contact Information Centre. Tel: +44 (0)20 8996 7111 Fax: +44 (0)20 8996 7048 Email: [info@bsigroup.com](mailto:info@bsigroup.com)

Subscribing members of BSI are kept up to date with standards developments and receive substantial discounts on the purchase price of standards. For details of these and other benefits contact Membership Administration. Tel: +44 (0)20 8996 7002 Fax: +44 (0)20 8996 7001 Email: [membership@bsigroup.com](mailto:membership@bsigroup.com)

Information regarding online access to British Standards via British Standards Online can be found at <http://www.bsigroup.com/BSOL>

Further information about BSI is available on the BSI website at <http://www.bsigroup.com>

### Copyright

Copyright subsists in all BSI publications. BSI also holds the copyright, in the UK, of the publications of the international standardization bodies. Except as permitted under the Copyright, Designs and Patents Act 1988 no extract may be reproduced, stored in a retrieval system or transmitted in any form or by any means – electronic, photocopying, recording or otherwise – without prior written permission from BSI.

This does not preclude the free use, in the course of implementing the standard, of necessary details such as symbols, and size, type or grade designations. If these details are to be used for any other purpose than implementation then the prior written permission of BSI must be obtained.

Details and advice can be obtained from the Copyright and Licensing Manager. Tel: +44 (0)20 8996 7070 Email: [copyright@bsigroup.com](mailto:copyright@bsigroup.com)