

BS ISO 1352:2011



BSI Standards Publication

Metallic materials — Torque-controlled fatigue testing

bsi.

...making excellence a habit.™

National foreword

This British Standard is the UK implementation of ISO 1352:2011.

The UK participation in its preparation was entrusted to Technical Committee ISE/101/6, Fatigue testing of metals and metal matrix composites.

A list of organizations represented on this committee can be obtained on request to its secretary.

This publication does not purport to include all the necessary provisions of a contract. Users are responsible for its correct application.

© BSI 2011

ISBN 978 0 580 53937 4

ICS 77.040.10

Compliance with a British Standard cannot confer immunity from legal obligations.

This British Standard was published under the authority of the Standards Policy and Strategy Committee on 31 August 2011.

Amendments issued since publication

Date	Text affected
------	---------------

INTERNATIONAL
STANDARD

BS ISO 1352:2011

ISO
1352

Second edition
2011-04-15

**Metallic materials — Torque-controlled
fatigue testing**

*Matériaux métalliques — Essais de fatigue par couple de torsion
commandé*



Reference number
ISO 1352:2011(E)

© ISO 2011



COPYRIGHT PROTECTED DOCUMENT

© ISO 2011

All rights reserved. Unless otherwise specified, no part of this publication may be reproduced or utilized in any form or by any means, electronic or mechanical, including photocopying and microfilm, without permission in writing from either ISO at the address below or ISO's member body in the country of the requester.

ISO copyright office
Case postale 56 • CH-1211 Geneva 20
Tel. + 41 22 749 01 11
Fax + 41 22 749 09 47
E-mail copyright@iso.org
Web www.iso.org

Published in Switzerland

Contents

Page

Foreword	iv
1 Scope	1
2 Normative references	1
3 Terms and definitions	1
4 Symbols and abbreviated terms	3
5 Principle of test.....	3
6 Test plan	4
7 Shape and size of specimen	4
7.1 Form.....	4
7.2 Dimensions	5
8 Preparation of specimens.....	6
8.1 General	6
8.2 Machining procedure	6
8.3 Sampling and marking.....	6
8.4 Surface conditions of specimen	7
8.5 Dimensional checks	7
8.6 Storage and handling.....	7
9 Apparatus.....	7
9.1 Testing machine	7
9.2 Instrumentation for test monitoring	9
10 Test procedure.....	9
10.1 Mounting of specimen	9
10.2 Speed of testing.....	9
10.3 Application of torque	9
10.4 Calculation of nominal torsional stress	10
10.5 Recording of temperature and humidity	10
10.6 Failure and termination criteria.....	10
11 Test report.....	10
Annex A (informative) Presentation of results.....	14
Annex B (informative) Verification of alignment of torsional fatigue testing machines	18
Annex C (informative) Measuring uniformity of torsional strain (stress) state	20
Bibliography.....	23

Foreword

ISO (the International Organization for Standardization) is a worldwide federation of national standards bodies (ISO member bodies). The work of preparing International Standards is normally carried out through ISO technical committees. Each member body interested in a subject for which a technical committee has been established has the right to be represented on that committee. International organizations, governmental and non-governmental, in liaison with ISO, also take part in the work. ISO collaborates closely with the International Electrotechnical Commission (IEC) on all matters of electrotechnical standardization.

International Standards are drafted in accordance with the rules given in the ISO/IEC Directives, Part 2.

The main task of technical committees is to prepare International Standards. Draft International Standards adopted by the technical committees are circulated to the member bodies for voting. Publication as an International Standard requires approval by at least 75 % of the member bodies casting a vote.

Attention is drawn to the possibility that some of the elements of this document may be the subject of patent rights. ISO shall not be held responsible for identifying any or all such patent rights.

ISO 1352 was prepared by Technical Committee ISO/TC 164, *Mechanical testing of metals*, Subcommittee SC 5, *Fatigue testing*.

This second edition cancels and replaces the first edition (ISO 1352:1977), which has been technically revised.

Metallic materials — Torque-controlled fatigue testing

1 Scope

This International Standard specifies the conditions for performing torsional, constant-amplitude, nominally elastic stress fatigue tests on metallic specimens without deliberately introducing stress concentrations. The tests are typically carried out at ambient temperature in air (ideally at between 10 °C and 35 °C) by applying a pure couple to the specimen about its longitudinal axis.

While the form, preparation and testing of specimens of circular cross-section and tubular cross-section are described in this International Standard, component and other specialized types of testing are not included. Similarly, low-cycle torsional fatigue tests carried out under constant-amplitude angular displacement control, which lead to failure in a few thousand cycles, are also excluded.

2 Normative references

The following referenced documents are indispensable for the application of this document. For dated references, only the edition cited applies. For undated references, the latest edition of the referenced document (including any amendments) applies.

ISO 554:1976, *Standard atmospheres for conditioning and/or testing — Specifications*

3 Terms and definitions

For the purposes of this document, the following terms and definitions apply.

3.1

maximum stress

τ_{\max}
highest algebraic value of shear stress in the stress cycle

3.2

minimum stress

τ_{\min}
lowest algebraic value of shear stress in the stress cycle

3.3

mean stress

τ_m
static component of the shear stress

NOTE It is one half of the algebraic sum of the maximum shear stress and the minimum shear stress:

$$\tau_m = \frac{\tau_{\max} + \tau_{\min}}{2}$$

3.4
stress amplitude

τ_a
variable component of stress

NOTE It is one half of the algebraic difference between the maximum shear stress and the minimum shear stress:

$$\tau_a = \frac{\tau_{\max} - \tau_{\min}}{2}$$

3.5
number of cycles

N
number of cycles applied at any stage during the test

3.6
stress ratio

R
algebraic ratio of the minimum shear stress to the maximum shear stress in one cycle

NOTE It is expressed as

$$R = \frac{\tau_{\min}}{\tau_{\max}}$$

3.7
stress range

$\Delta\tau$
range between the maximum and minimum shear stresses

NOTE It is expressed as

$$\Delta\tau = \tau_{\max} - \tau_{\min}$$

3.8
fatigue life at failure

N_f
number of stress cycles to failure in a specified condition

3.9
fatigue strength at N cycles

τ_N
value of the shear stress amplitude at a stated stress ratio under which the specimen would have a life of N cycles

3.10
torque

T
twisting force producing shear stress or twisting deformation about the axis of the specimen

4 Symbols and abbreviated terms

D	diameter or width across flats of the gripped ends of the specimen
	NOTE The value of D may be different for each end of the specimen.
d	diameter of specimen of circular cross-section, where stress is maximum
d_o	outer diameter of test section of specimen of tubular cross-section, where stress is maximum
d_i	inner diameter of test section of specimen of tubular cross-section
L_c	length of test section
L_p	parallel length of specimen's test section
L_g	gauge length of the specimen's test section
r	transition blending radius at ends of test section which starts the transition from d to D (see Figures 3 and 4)
	NOTE This curve need not be a true arc of a circle over the whole of the distance between the end of the test section and the start of the enlarged end for specimens of the types shown in Figure 3.

5 Principle of test

Nominally identical specimens are mounted on a torsional fatigue testing machine and subjected to the loading condition required to introduce cycles of torsional stress. Any one of the types of cyclic stress illustrated in Figure 1 may be used. The test waveform shall be constant-amplitude sinusoidal, unless otherwise specified.

In an axially symmetrical specimen, change of mean torque does not introduce a different type of stress system and mean stress in torsion may always be regarded as positive in sign.

The torque is applied to the specimen about the longitudinal axis passing through the centroid of the cross-section.

The test is continued until the specimen fails or until a predetermined number of stress cycles has been exceeded.

Cracks produced from torsional fatigue testing may be parallel to the longitudinal axis of the specimen, perpendicular to the longitudinal axis or at any angle between these two.

Tests shall be conducted at ambient temperature (ideally between 10 °C and 35 °C) unless otherwise agreed with the customer.

The results of fatigue testing can be affected by atmospheric conditions, and where controlled conditions are required, ISO 554:1976, 2.1, applies.

6 Test plan

Before commencing testing, the following shall be agreed by the parties concerned and any modifications shall be mutually agreed upon:

- a) the form of specimen to be used (see Clause 7);
- b) the stress ratio(s) to be used;
- c) the objective of the tests, i.e. which of the following is to be determined:
 - the fatigue life at a specified stress amplitude;
 - the fatigue strength at a specified number of cycles;
 - a full Wöhler or S–N curve;
- d) the number of specimens to be tested and the test sequence;
- e) the number of cycles a specimen is subjected to before the test is terminated.

NOTE 1 Some methods of data presentation are given in Annex A. See ISO 12107 for details, including data analysis procedure and statistical presentation.

NOTE 2 Commonly employed numbers of cycles for test termination are

- 10^7 cycles for structural steels, and
- 10^8 cycles for other steels and non-ferrous alloys.

7 Shape and size of specimen

7.1 Form

Generally, a specimen having a fully machined test section of one of the types shown in Figures 3 and 4 should be used.

The specimen may be of

- circular cross-section, with tangentially blending fillets between the test section and the ends (see Figure 3), or
- tubular cross-section, with tangentially blending fillets between the test section and the ends in the outer surface (see Figure 4).

For tubular specimens, the diameter of the inner surface at the ends may be greater than or equal to that at the test section. For a specimen having a inner diameter at the ends greater than that at the test section, crack initiation or failure outside the test section invalidates the test, which should be counted as a discontinued (stopped) test at the number of cycles completed.

Fatigue test results determined using the specimen of tubular cross-section are not always comparable to those obtained from the specimen of circular cross-section. Therefore, caution should be exercised when comparing fatigue lives obtained on the same material from specimens having different cross-sections.

Typical specimen ends are shown in Figure 5. It is recommended that ends suitable for meeting the alignment criterion be chosen.

7.2 Dimensions

7.2.1 Specimens of circular cross-section

It is recommended that the geometric dimensions given in Table 1 be used (see also Figure 3).

Table 1 — Dimensions for specimens of circular cross-section

Diameter of cylindrical gauge length, in millimetres	$5 \leq d \leq 12$
Length of test section	$L_c \leq 5d$
Transition radius (from parallel section to grip end)	$r \geq 3d$
External diameter (grip end)	$D \geq 2d$
The tolerance on d shall be $\pm 0,05$ mm.	

To calculate the applied torque loading, the actual diameter of each specimen shall be measured to an accuracy of 0,01 mm. Care should be taken not to damage the surface when measuring the specimen prior to testing.

It is important that general tolerances of the specimen respect the two following properties:

- parallelism: 0,005 d or better
- concentricity: 0,005 d or better

These values are expressed in relation to the axis or reference plane.

7.2.2 Specimens with tubular cross-section

In general, the considerations applicable to specimens of circular cross-section also apply to tests on tubular specimens.

The specimen wall thickness shall be large enough to avoid instabilities during cyclic loading without violating the thin-walled tube criterion, i.e. a mean diameter-to-wall thickness ratio of 10:1 or greater is required.

It is recommended that the geometric dimensions given in Table 2 be used (see also Figure 4).

Table 2 — Dimensions for specimens of tubular cross-section

Wall thickness in test section, t	0,05 d_o to 0,1 d_o
Outer diameter of test section	d_o
Transition radius (from parallel section to grip end), r	$\geq 3d_o$
Length of test section, L_c	1 d_o to 3 d_o
External diameter (grip end)	$D \geq 1,5d_o$
Concentricity between the outer diameter, d_o , and the inner diameter, d_i , should be maintained within 0,01 t .	

8 Preparation of specimens

8.1 General

In any fatigue test programme designed to characterize the intrinsic properties of a material, it is important to observe the following recommendations in the preparation of specimens. Deviation from these recommendations is permitted if the test program aims to determine the influence of a specific factor (surface treatment, oxidation, etc.). In all cases, any deviations shall be noted in the test report. Specimens should be machined from normally stress-free material unless otherwise agreed with the customer.

8.2 Machining procedure

Machining the specimens can induce residual stress on the specimen surface that could affect the test results. These stresses can be induced by heat gradients at the machining stage — stresses associated with deformation of the material or microstructural alterations. However, they can be reduced by using an appropriate final machining procedure, especially prior to a final polishing stage. For harder materials, grinding rather than tool operation (turning or milling) may be preferable.

- Grinding: from 0,1 mm of the final dimension at a rate of no more than 0,005 mm/pass.
- Polishing: remove the final 0,025 mm with papers of decreasing grit size. It is recommended that the final direction of polishing be along the specimen axial direction.
- For tubular specimens the bore should be fine-honed.

Failure to observe the above can result in alteration in the microstructure of the material. This phenomenon can be caused by an increase in temperature and by the strain-hardening induced by machining; it can be a matter of a change in phase or, more frequently, of surface recrystallization. This invalidates the test as the material mechanical properties are changed.

Introduction of contaminants: the mechanical properties of some materials deteriorate when in the presence of certain elements or compounds. An example is the effect of chlorine on steels and titanium alloys. These elements should therefore be avoided in the products used during specimen preparation (cutting fluids, etc.). Rinsing and degreasing of specimens prior to storage is also recommended.

8.3 Sampling and marking

The sampling of test materials from a semi-finished product or component can have a major influence on the results obtained during the test. It is therefore necessary to clearly identify the location and orientation of each specimen.

A sampling drawing, attached to the test report, shall indicate clearly

- the position of each of the specimens,
- the characteristic directions in which the semi-finished product has been worked (direction of rolling, extrusion, etc., as appropriate), and
- the marking of each of the specimens.

Specimens shall carry a unique identifying mark throughout their preparation. This may be applied using any reliable method in an area not likely to disappear during machining or to adversely affect the quality of the test.

Identification shall be applied to each end of the specimen before testing.

8.4 Surface conditions of specimen

The surface conditions of the specimens can affect the test results. This is generally associated with one or more of the following factors:

- specimen surface roughness;
- presence of residual stresses;
- alteration in the microstructure of the material;
- introduction of contaminants.

To minimize the impact of these factors, the following is recommended.

The impact of surface roughness on the results obtained depends largely on the test conditions and its effect is reduced by surface corrosion of the specimen or inelastic deformation.

It is preferable, whatever the test conditions, to achieve a mean surface roughness of less than $0,2 \mu\text{m } R_a$ (or equivalent) within the parallel section.

Another important parameter not covered by mean roughness is the presence of localized machining scratches. Finishing operations should eliminate all circumferential scratches produced during turning. Final grinding followed by mechanical polishing is highly recommended. A visual inspection at low magnification (approximately $\times 20$) should only show polishing marks appropriate to the grade of the final polishing medium.

It is preferable to carry out a final polishing operation after heat treatment. If this is not possible, the heat treatment should be carried out in a vacuum or in inert gas to prevent oxidation of the specimen surface. This treatment should not alter the microstructural characteristics of the material under study. The details of the heat treatment and machining procedure shall be reported with the test results.

8.5 Dimensional checks

The dimensions should be measured on completion of the final machining stage using a method of metrology which does not alter the surface condition.

8.6 Storage and handling

After preparation, the specimens should be stored so as to prevent any risk of damage (scratching by contact, oxidation, etc.). If there is any damage on the surface of the specimen during storage, it should be removed by repolishing the specimen. The use of individual boxes or tubes with end caps is recommended. In certain cases, storage in a vacuum or in a desiccator is necessary.

Handling should be reduced to the minimum necessary. Particular attention shall be given to marking of the specimen. Identification shall be applied to each end of the specimen before testing.

9 Apparatus

9.1 Testing machine

9.1.1 General

The tests shall be carried out on a testing machine having a clockwise/anticlockwise (counter-clockwise) torsional loading capability, with smooth start and no backlash when passing through zero. The test start settings shall allow the required level to be reached without any overload. The time frame for reaching the required level should be as short as reasonably possible.

The machine should have adequate lateral and torsional stiffness and alignment.

The complete machine loading system (including torque cell, grips, and specimen) shall be capable of controlling and measuring torque when the recommended wave cycle is applied. The specimen shall be unconstrained in the axial direction to prevent extraneous forces being introduced.

The testing machine torque measuring system shall be verified statically using a suitable method of calibration and shall be traceable to national standards.

It is important to recognize the potential effect of dynamic errors introduced by the inertial mass between the torque cell and the specimen. Inertia torque errors, expressed as a percentage of torque range, can be expected to vary with frequency and are strongly influenced by specimen compliance. For details, see ISO 4965, which, although intended for axial fatigue testing, gives principles that also apply to torsional fatigue testing.

The machine shall be equipped with a cycle-counting system accurate to 1 % and shall be able to shut down automatically when the specimen fails.

9.1.2 Torque cell

The torque cell shall be fatigue rated. The indicated torque, as recorded at the output from the computer in an automated system, or from the final output recording device in a non-automated system, shall be within specified limits. The torque cell capacity shall be sufficient to cover the range of torque measured during a test to an accuracy of 1 % of the reading or better. The torque cell shall be temperature-compensated and should have a zero drift no greater than 0,002 % of full scale per degree Celsius. Sensitivity variation should not be greater than 0,002 % of full scale per degree Celsius.

9.1.3 Gripping of specimen

The gripping device shall transmit the cyclic torques to the specimen without backlash along its circumferential direction for the duration of the test. The geometric qualities of the device shall ensure correct alignment so that it is in accordance with 9.1.4.

The gripping device shall enable repeatable assembly and have surfaces that ensure alignment of the specimen. It shall also allow transmission of reversed torque without backlash throughout the duration of the test.

9.1.4 Alignment check

It is important that the best uniform stress distribution be obtained for every fatigue test. Axial alignment of the test machine for both axial fatigue machines and torsional fatigue machines is measured using an alignment check methodology^[3].

NOTE 1 Annex B briefly describes the alignment check methodology.

In addition, it is important to document the applied stress distribution in the test section of the fatigue specimen. This applied stress uniformity is controlled by both the test machine and the specimen.

NOTE 2 Annex C describes a procedure for measuring and documenting the applied stress uniformity for torsional tests.

The stress uniformity may be checked before each series of tests or whenever a change is made to the load train.

9.1.5 Axial force

For torsional testing, the axial force shall be zero.

9.2 Instrumentation for test monitoring

9.2.1 Recording system

A device for measuring applied torque against time with an accuracy of 1% of full scale of the torque cell shall be considered as a minimum requirement for the recording of data.

Computerized data collection systems shall have collection rates fast enough to meet this requirement; non-computerized data collection systems may need a high-speed recorder or storage device, which can then be played back at a slower rate to determine the peak and valley torque magnitude for each cycle.

9.2.2 Cycle counter

A cycle counter is essential for recording the number of cycles applied; it shall stop automatically on specimen failure.

9.2.3 Checking and verification

The proper operation of the testing machine and its control and measurement systems should be checked annually or more frequently if required. The time interval between verifications shall not exceed 13 months, except for testing machines being used in long-term tests that exceed this period, in which case the test machine shall be verified upon completion of the test.

Specifically, each transducer and associated electronics shall always be checked as a unit.

The torque measuring system(s) shall be traceable to a national standard.

10 Test procedure

10.1 Mounting of specimen

Care should be taken to ensure that each specimen is located in the driven and stationary (top and bottom, left and right) grips so that the axis of the specimen lies along the axis of torsion of the testing machine and the intended stress pattern is imposed. Care should also be taken to ensure that no (or minimal) axial stress is applied to the specimen during the mounting of the specimen on the testing machine.

10.2 Speed of testing

The frequency of the torque cycle will depend upon the type of testing machine employed and the test programme requirements. The frequency chosen shall be that suitable for the particular combination of material, specimen and testing machine.

At high frequencies, substantial heating of the specimen can occur, which could affect the test fatigue life and strength results. In such cases, it is advisable to record the increase in temperature and to include it in the test report. If the test programme allows, the test frequency should be reduced if the specimen temperature increase is excessive for the material.

NOTE If the influence of the environment is significant, the test result is likely to be frequency-dependent.

10.3 Application of torque

The general procedure for attaining full-torque running conditions shall be the same for each specimen. The mean torque and torque range shall be maintained within ± 1 % of the torque range.

10.4 Calculation of nominal torsional stress

Torsional (shear) stress, τ , results from the torque, T , applied to the specimens of circular and tubular cross-sections. The torsional stress is always largest at the outer diameter of the test section. Under elastic loading conditions, the nominal torsional stress varies linearly from zero at the axis of twist to a maximum at the outer diameter, and the following calculation of torsional stress, τ , is recommended:

$$\tau = \frac{16T}{\pi d^3} \quad \text{at the outer diameter for solid specimens of circular cross-section;}$$

$$\tau = \frac{16Td_o}{\pi(d_o^4 - d_i^4)} \quad \text{at the outer diameter for specimens of tubular cross-section.}$$

10.5 Recording of temperature and humidity

The maximum and minimum air temperatures and the humidity shall be recorded daily for the duration of the test.

If specimen self-heating is of concern, the temperature of the specimen shall be monitored and recorded.

10.6 Failure and termination criteria

10.6.1 Failure

Unless otherwise agreed, the criterion for specimen failure shall be specimen separation.

In particular applications, other criteria (for example, the occurrence of a visible fatigue crack, plastic deformation of the specimen or the rate of crack propagation) may be adopted.

10.6.2 Termination

The test shall be terminated when either the specimen fails or a predetermined number of cycles is completed, as agreed by the concerned parties.

11 Test report

The test report shall include reference to this International Standard as well as the following information for the test series, if available:

- material tested, its metallurgical characteristics, mechanical properties, and any heat treatment given to the specimen(s);
- location of the specimen(s) in the parent material;
- form and nominal dimensions of the specimen(s);
- surface condition of the specimen(s).

The test report shall include the following for each individual specimen:

- a) cross-sectional dimensions;
- b) minimum and maximum peak torque applied;
- c) applied stress conditions;

- d) frequency and fatigue life;
- e) a description of the testing machine used, its type and serial number, the torque cell and serial number, number and load train description;
- f) temperature of the specimen if self-heating occurs (i.e. greater than 35 °C);
- g) maximum and minimum air temperatures and relative humidity;
- h) criterion for ending the test, i.e. its duration (e.g. 10^7 cycles), or complete failure of the specimen, or any other criterion;
- i) any special observations or deviations from the required test conditions.

Additionally, test results may be presented graphically.

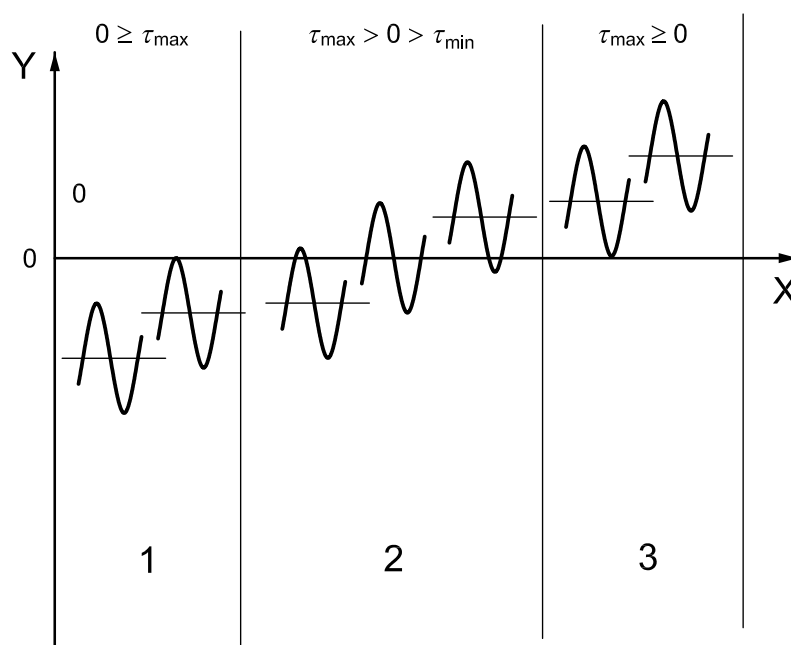

Key

X time

Y stress

1 fluctuating compression

2 reversed

3 fluctuating tension

Figure 1 — Types of cyclic stress

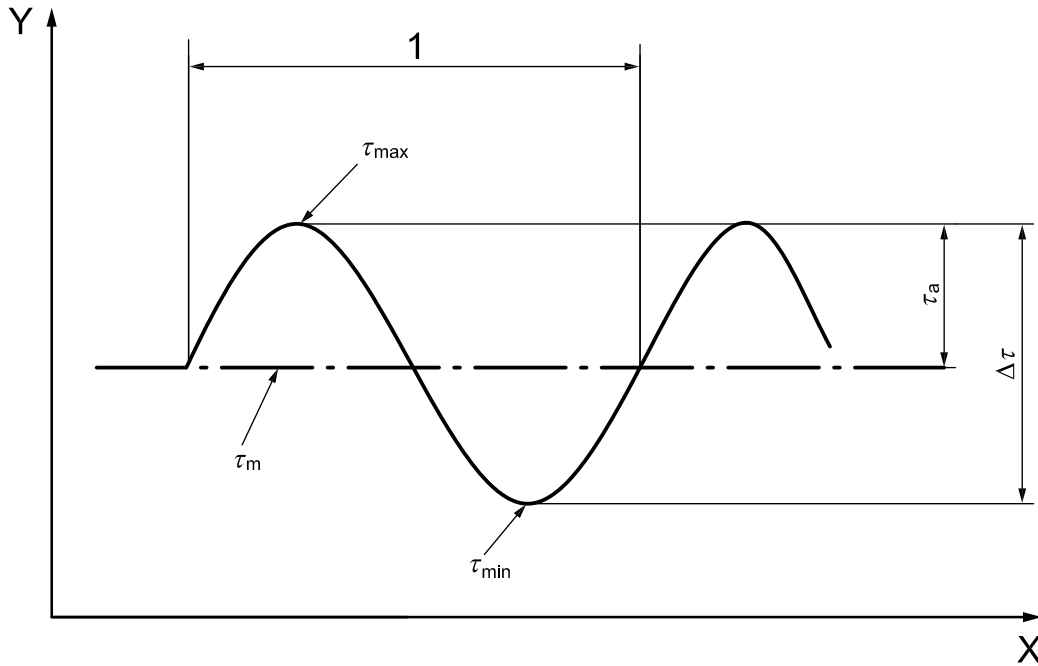

Key

X time

Y stress

1 one stress cycle

Figure 2 — Fatigue stress cycle

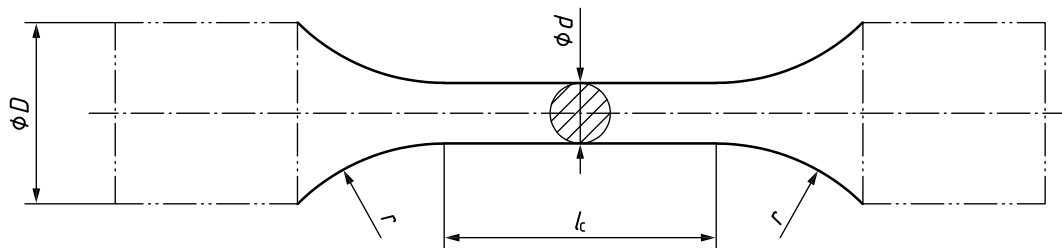

Figure 3 — Test pieces with circular cross-section

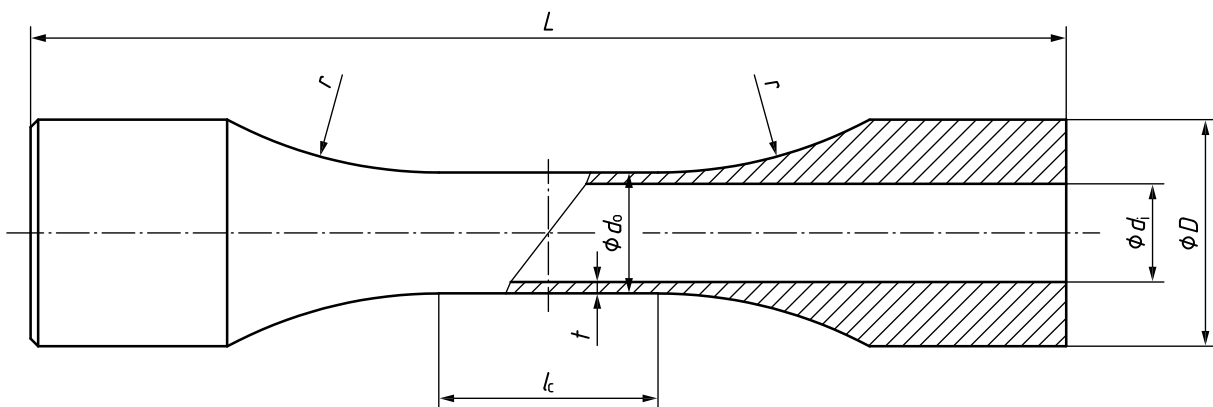

Figure 4 — Test piece with tubular cross-section

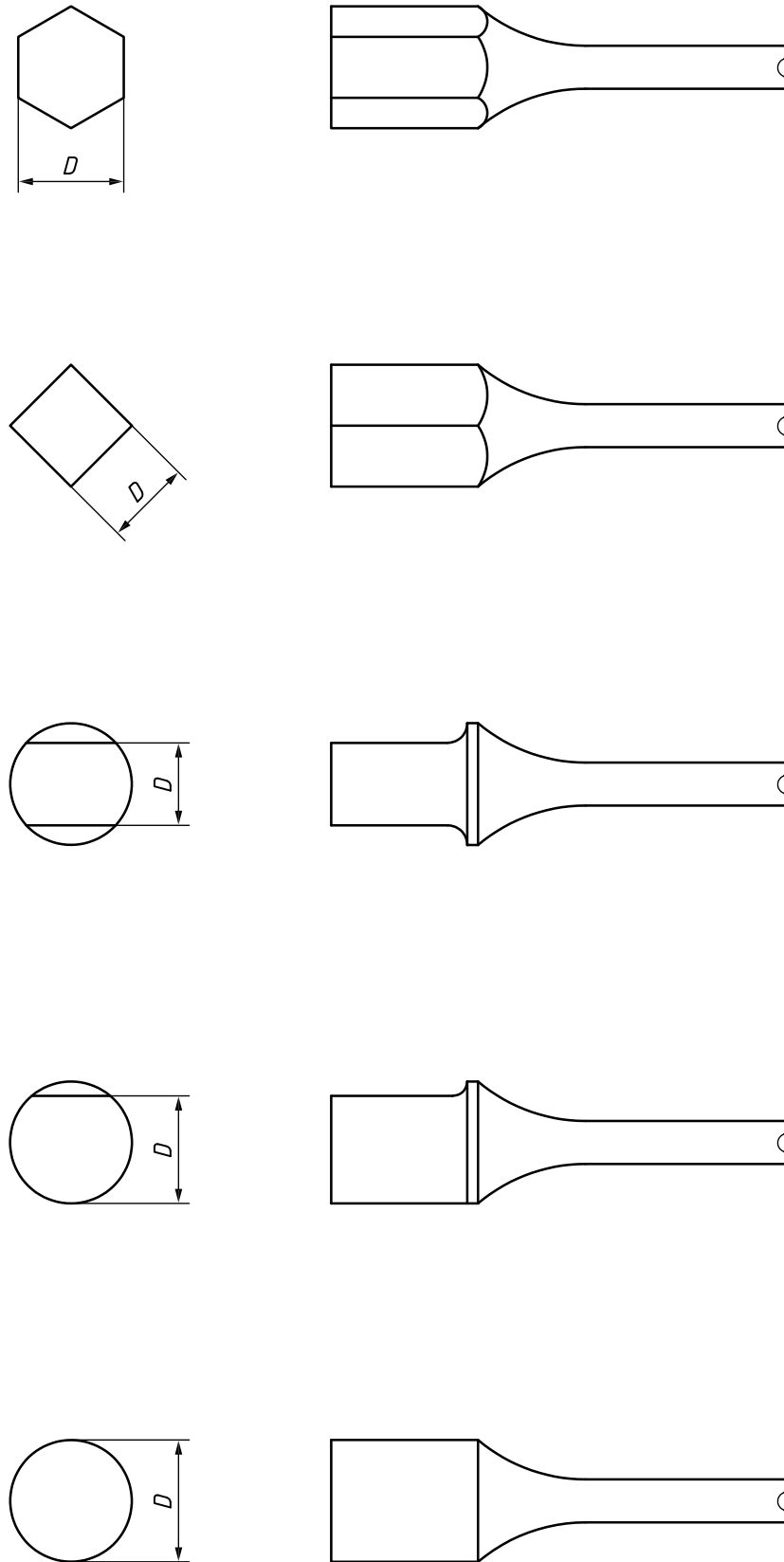

Figure 5 — Typical specimen ends

Annex A (informative)

Presentation of results

A.1 General

The design of the investigation and the use to be made of the results govern the choice of the most suitable method for presenting the results, graphically or otherwise, from the many available methods. The results of fatigue tests are usually presented graphically. In reporting fatigue data, the test conditions should be clearly defined.

A.2 Wöhler or S–N curve

The most general method of graphically presenting the results is to plot the number of cycles to failure as the abscissa and the values of stress amplitude or (depending on the type of stress cycle) those of any other stress as the ordinate. The curve drawn smoothly as an approximate middle line through the experimental points is called a Wöhler or S–N curve. A logarithmic scale is used for the number of cycles and the choice of using either a linear or logarithmic scale for the stress axis lies with the experimenter. Individual curves are plotted for each set of tests for each R ratio. Experimental results are usually plotted on the same figure. An example is shown in Figure A.1, where a linear stress scale is used.

A.3 Mean stress diagrams

The fatigue strengths derived from the Wöhler or S–N curve are plotted as fatigue strength diagrams. The results can be represented by a graph giving directly, for particular endurance, the stress amplitude against the mean stress, as shown in Figure A.2 (Haigh diagram), or by plotting the maximum and minimum stresses against the mean stress, as shown in Figure A.3 (Smith diagram). Experimental results may be plotted on the same figure.

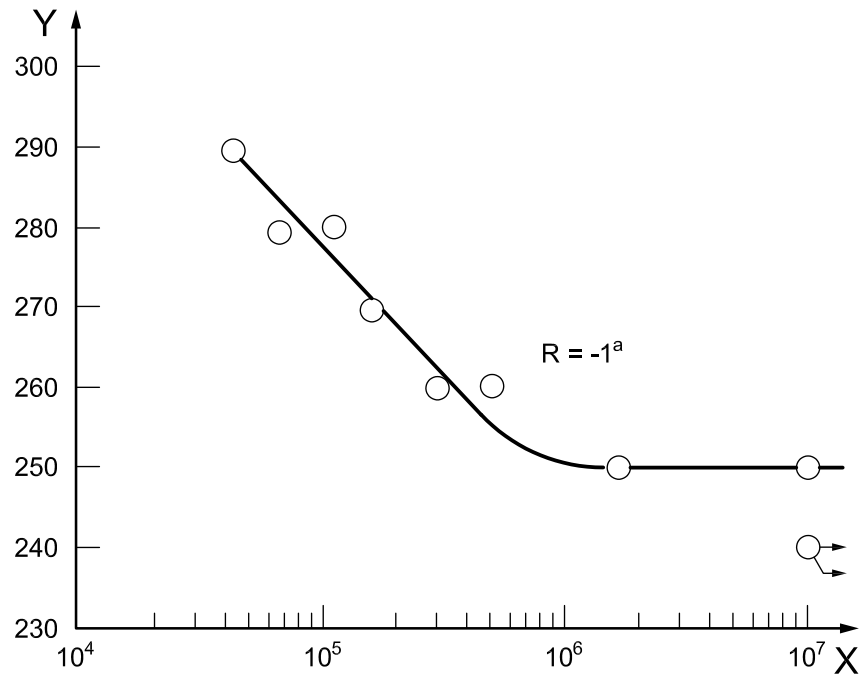

Key

X number of cycles to failure, N
Y stress amplitude, τ_a , N/mm²

^a Ambient temperature.

Figure A.1 — Wöhler or S-N curve

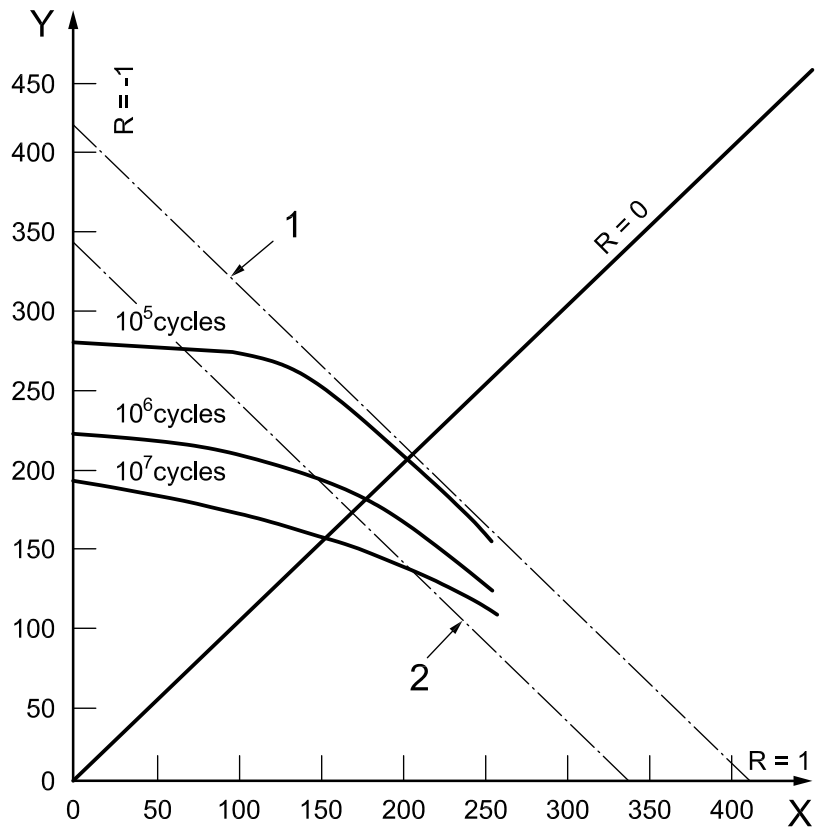

Key

- X mean stress, τ_m , N/mm²
- Y stress amplitude, τ_a , N/mm²
- 1 shear stress
- 2 0,2 % proof stress

Figure A.2 — Stress amplitude against mean stress — Haigh diagram

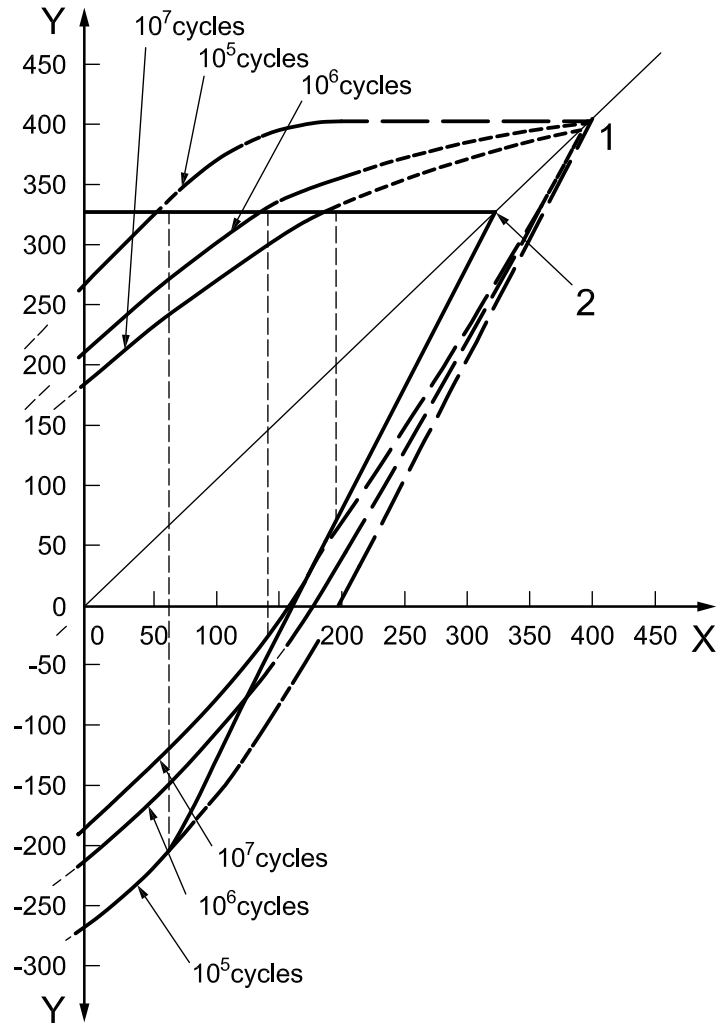

Key

X mean stress, τ_m , N/mm^2

Y maximum and minimum stresses, τ_{\max} and τ_{\min} , N/mm^2

1 shear stress

2 0,2 % proof stress

Figure A.3 — Maximum and minimum stresses against mean stress — Smith diagram

Annex B (informative)

Verification of alignment of torsional fatigue testing machines

B.1 The alignment check shall be carried out using a standard axial alignment specimen or bar alignment device. The bar alignment device is illustrated in Figure B.1, and the axial alignment specimen, shown in Figure B.2, should be of a geometry similar to the specimens being tested. It is recommended that the alignment specimen be made from a hardened heat-treated steel.

B.2 The bar alignment device, as a non-strain-gauged device, may be useful for checking the alignment in the test system both qualitatively and relatively quickly. The device, as illustrated in Figure B.1, should consist of a split bar and a sleeve, both made to precise tolerances. It is recommended that the sleeve and bar be made of the same materials.

B.3 In order to check the misalignment due to angular offset, lateral offset and/or load train offset, the axial strain-gauged alignment specimen should have resistance strain gauges secured at the locations illustrated in Figure B.2. With the top or bottom (not both) of the strain-gauged specimen secured in the gripping arrangement, the temperature should be allowed to equilibrate and the zero reference adjustments to the bridge amplifiers be made. At this time, the alignment specimen should be gripped in both the upper and lower grips.

B.4 The gauged specimen should be loaded in torsion to a maximum tensile strain of 0,4 %, or to a torque corresponding to the maximum torsional strain to be imposed on specimens in the test series if this value does not exceed 0,4 % strain of the gauge specimen. The maximum bending strains are calculated according to the scheme described in Reference [3], in which the bending strains are separated into the machine contribution and the specimen contribution. If the maximum bending strain for the machine contribution exceeds 50 microstrains in one or more of the two instrumented planes, adjustments should be made in the test frame actuator or fixtures and/or force transducer, followed by a repetition of the procedure until 50 microstrains is achieved.

It is recommended that the general procedure for preparation of the alignment specimen and checking of the alignment follow that described in Reference [3].

Care should be taken when applying a series of torsional loads or torsional strains to the specimen because the axial strain gauges cannot sense the torsional strain or deformation imposed on the specimen. Therefore, it is recommended that the torsional loads to be imposed on the specimen be pre-determined using another specimen with the same dimension and material as the gauged specimen.

B.5 The procedure should be repeated in reversed torsion to ascertain that the alignment is within that specified (i.e. < 5,0 %).

B.6 If the check is not satisfactory,

- the reproducibility of the measurements shall be verified by carrying out the process several times,
- it shall be established that the results are attributable to the test assembly and not to the specimen, and
- the elements making up the gripping train (instruments, cell, machine) shall be checked for geometric accuracy.

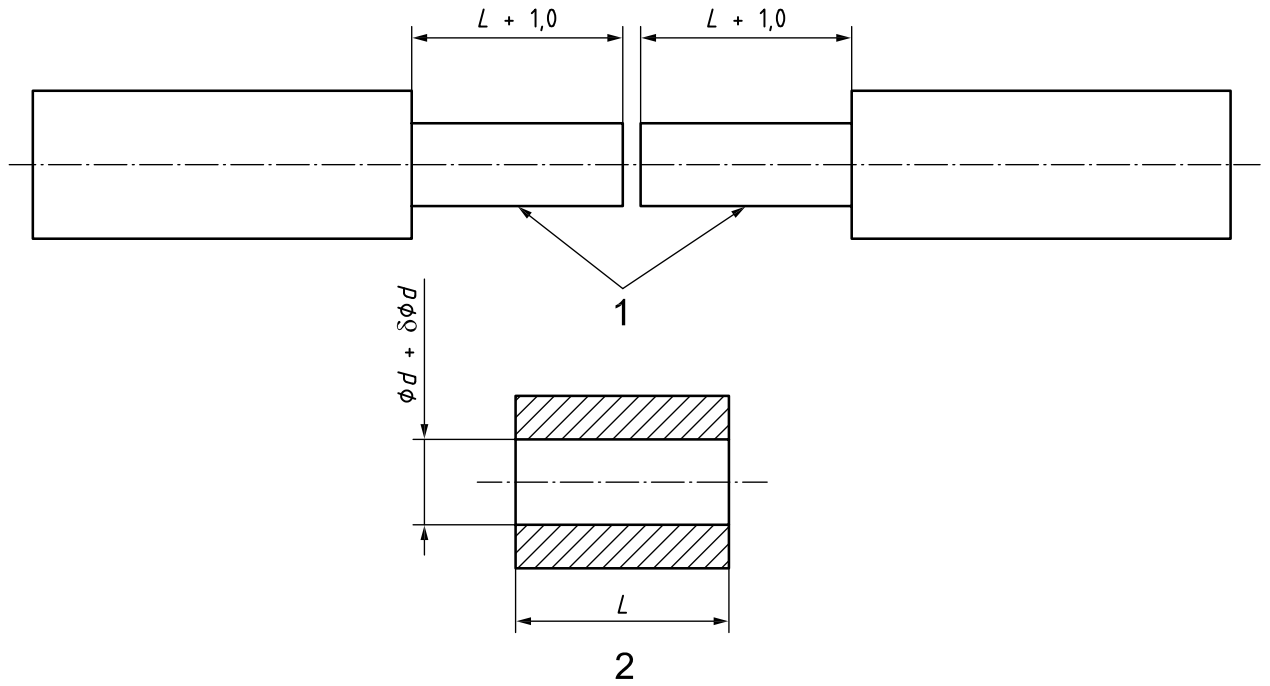

- Key**
- 1 split bar
 - 2 sleeve

Figure B.1 — Example of alignment bar

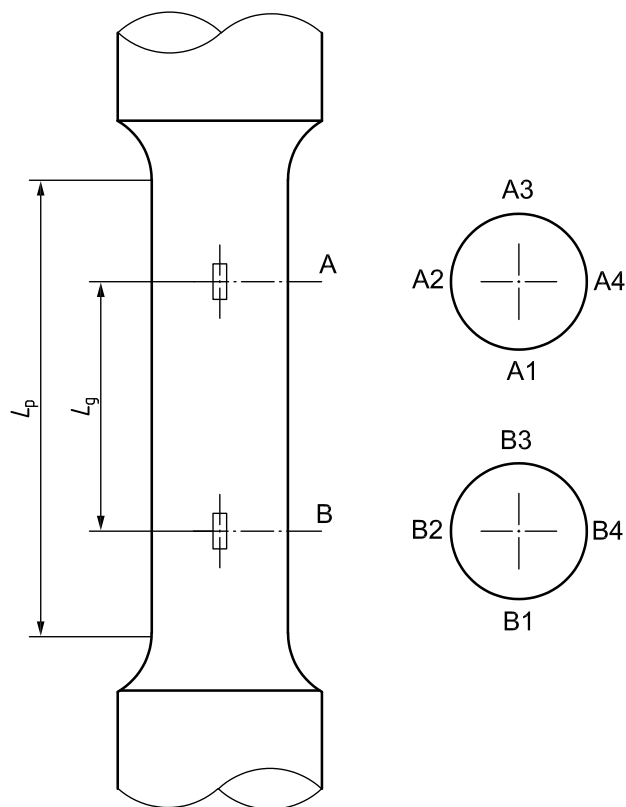

Figure B.2 — Strain-gauged specimen

Annex C (informative)

Measuring uniformity of torsional strain (stress) state

C.1 It is important for any fatigue test that the best possible uniform stress distribution in the test section of every fatigue specimen be obtained prior to the actual fatigue test. Fatigue life is typically controlled by a combination of the highest stress and the largest defect within the specimen. The failure location is most likely not the location of the highest stress nor at the largest defect; but the actual failure location is controlled by a combination of both stress and defect size. By testing specimens with uniform stress distributions, all defects will be subjected to the same stress and failure will occur at the most critical defect. Fatigue scatter is reduced when the test section is increased and when the stress is uniform.

The uniformity of the applied stress is controlled by both the test machine and the specimen. To measure the uniformity of the applied torsional stress, the strain gauges need to be at 45° to the specimen axis, which is the direction of the applied principal stress.

C.2 It is always better to select one representative specimen from the group of actual test specimens to be strain-gauged so that the machine contribution and the specimen contribution to the uniformity of the applied stresses can be measured at the same time. For torsional testing, it is recommended that either the strain gauges be oriented at 45° to the specimen axis or an array of four 45° strain gauge rosettes be used, as illustrated in Figure C.1 a). The principal stress direction for a pure torsion specimen is 45° to the specimen axis. Therefore, single gauges orientated 45° to the specimen axis or rosettes will measure the principal stress. The strain gauges shall be equally spaced, 90° apart, around the circumference of the specimen in the same cross-sectional plane. The axial directions of the rosettes should be aligned to within ±2° of the longitudinal axis of the specimen.

In case four-gauge rosettes cannot be arranged in the same cross-sectional plane, they may be arranged in two sets of two-gauge rosettes as shown in Figure C.1 b)

It is recommended that all the strain gauge rosettes be matched and have active lengths of approximately $0,1 L_c$ or less.

C.3 The temperature during checking should be allowed to equilibrate and the zero reference adjustments to the bridge amplifiers should be accomplished with the top or bottom (not both) of the rosette-gauged specimen secured in the gripping arrangement. At this time, the specimen should be gripped in both the upper and lower grips.

The strain-measuring equipment and data acquisition systems shall have a resolution of at least 1 microstrain and an accuracy to within ±0,5 % of the indicated reading or ±3 microstrains, whichever is the greater.

C.4 The gauged specimen should be loaded in torsion to the torque corresponding to the maximum torsional strain to be imposed on specimens in the test series, if this value does not exceed 0,4 % strain of the gauged specimen. If strain gauge rosettes are used, then the normal strain components [normal strains in the axial, circumferential and shear (45°) strain directions] are determined according to the analysis of strain gage rosette data. The procedure should be repeated in reversed torsion and the normal strain components in the three directions (0°, 45° and 90°) and at the four instrumented points should be reported. If only 45° strain gauges are used, report the normal strain component measured by the 45° gauges.

C.5 Once the procedure given in C.4 has been completed, the strain-gauged specimen is removed from the testing machine and rotated 180°, installed in the test machine, and the C.4 procedure repeated. At the completion of these two sets of torque application, the strain gauge data can be separated using the equations given in Reference [3] into the machine contribution for non-uniform stress state and the specimen contribution for non-uniform stress state. If rosette strain gauges are used, then those equations will need to be used for each of the three-strain gauges within the rosette to separate the machine contribution from the specimen contribution. After separation, the direction and magnitude of the uniformity of the applied stress can be determined for both the machine contribution and specimen contribution using standard analysis for strain gauge rosette data.

C.6 Ideally, if every specimen could be strain-gauged, then the results calculated according to C.5 could be used to rotate the specimen to a position within the test machine to obtain the best uniform stress distribution prior to testing. Unfortunately, this would be very costly and is therefore not typically done. However, the information obtained from one representative specimen does provide important information on the quality of the specimen fabrication and how uniform the stress distribution would be for a perfect specimen (machine contribution for non-uniform stress state). If the specimen contribution to the non-uniform stress state is large, then more care is needed during specimen fabrication. If the machine contribution to the non-uniform stress state is large and the axial alignment is relatively good, then the axis of rotation of the torque actuator is not aligned with the rest of the machine.

C.7 In summary, it is critical to obtain the best uniform stress distribution within the test section of every possible specimen.

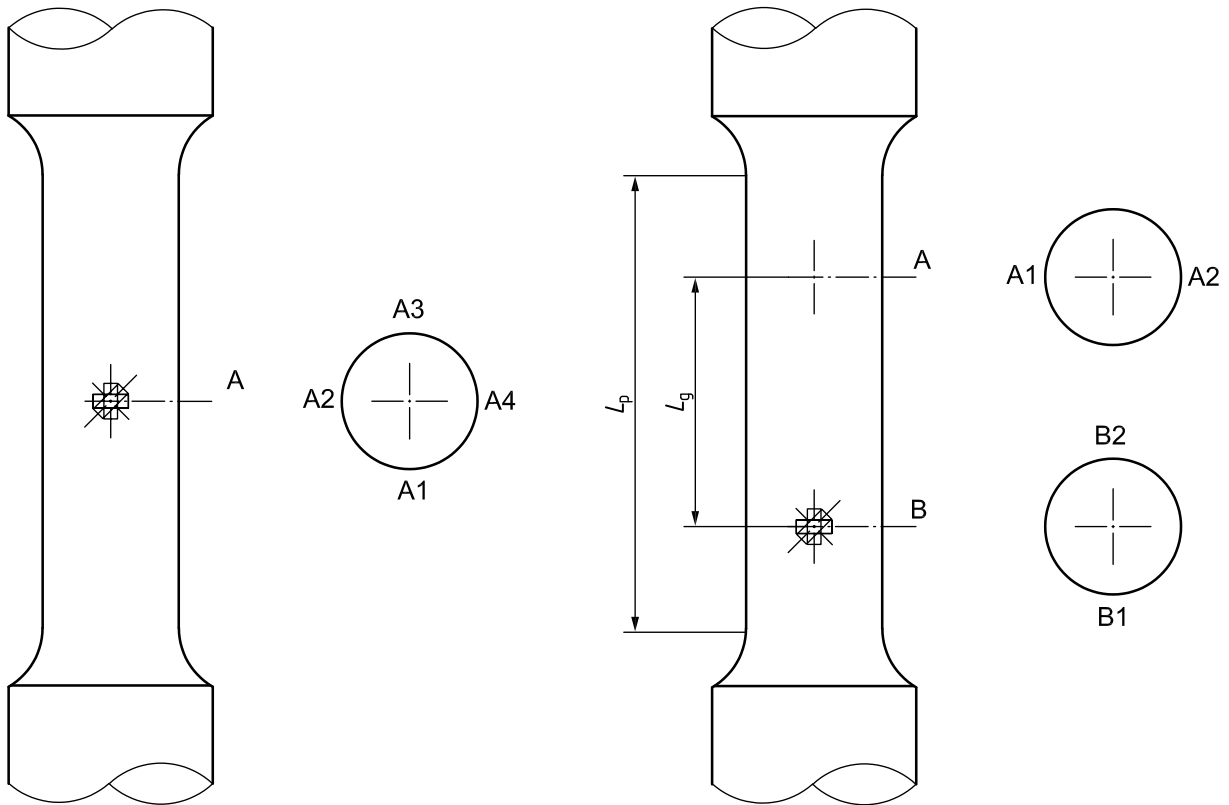

a) Four-gauge rosettes

b) two sets of two-gauge rosettes

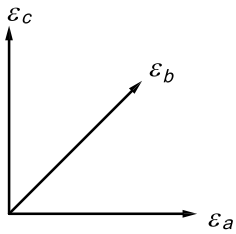

$$\varepsilon_{\theta\theta} = \varepsilon_a$$

$$\varepsilon_{zz} = \varepsilon_c$$

$$\gamma_{\theta z} = 2\varepsilon_b - \varepsilon_a - \varepsilon_c$$

0° -45° -90° strain gauge rosette

Figure C.1 — Strain-gauged specimen

Bibliography

- [1] ISO 4965:1979, *Axial load fatigue testing machines — Dynamic force calibration — Strain gauge technique*
- [2] ISO 12107, *Metallic materials — Fatigue testing — Statistical planning and analysis of data*
- [3] KANDIL, F.A., A Procedure for the Measurement of Machine Alignment in Axial Testing, *VAMAS Report No.42*, ISSN 1016-2186, National Physical Laboratory, February 2003
- [4] ASTM E2207-08, *Standard Practice for Strain-Controlled Axial-Torsional Fatigue Testing with Thin-Walled Tubular Specimens*

British Standards Institution (BSI)

BSI is the national body responsible for preparing British Standards and other standards-related publications, information and services.

BSI is incorporated by Royal Charter. British Standards and other standardization products are published by BSI Standards Limited.

About us

We bring together business, industry, government, consumers, innovators and others to shape their combined experience and expertise into standards-based solutions.

The knowledge embodied in our standards has been carefully assembled in a dependable format and refined through our open consultation process. Organizations of all sizes and across all sectors choose standards to help them achieve their goals.

Information on standards

We can provide you with the knowledge that your organization needs to succeed. Find out more about British Standards by visiting our website at bsigroup.com/standards or contacting our Customer Services team or Knowledge Centre.

Buying standards

You can buy and download PDF versions of BSI publications, including British and adopted European and international standards, through our website at bsigroup.com/shop, where hard copies can also be purchased.

If you need international and foreign standards from other Standards Development Organizations, hard copies can be ordered from our Customer Services team.

Subscriptions

Our range of subscription services are designed to make using standards easier for you. For further information on our subscription products go to bsigroup.com/subscriptions.

With **British Standards Online (BSOL)** you'll have instant access to over 55,000 British and adopted European and international standards from your desktop. It's available 24/7 and is refreshed daily so you'll always be up to date.

You can keep in touch with standards developments and receive substantial discounts on the purchase price of standards, both in single copy and subscription format, by becoming a **BSI Subscribing Member**.

PLUS is an updating service exclusive to BSI Subscribing Members. You will automatically receive the latest hard copy of your standards when they're revised or replaced.

To find out more about becoming a BSI Subscribing Member and the benefits of membership, please visit bsigroup.com/shop.

With a **Multi-User Network Licence (MUNL)** you are able to host standards publications on your intranet. Licences can cover as few or as many users as you wish. With updates supplied as soon as they're available, you can be sure your documentation is current. For further information, email bsmusales@bsigroup.com.

BSI Group Headquarters

389 Chiswick High Road London W4 4AL UK

Revisions

Our British Standards and other publications are updated by amendment or revision.

We continually improve the quality of our products and services to benefit your business. If you find an inaccuracy or ambiguity within a British Standard or other BSI publication please inform the Knowledge Centre.

Copyright

All the data, software and documentation set out in all British Standards and other BSI publications are the property of and copyrighted by BSI, or some person or entity that owns copyright in the information used (such as the international standardization bodies) and has formally licensed such information to BSI for commercial publication and use. Except as permitted under the Copyright, Designs and Patents Act 1988 no extract may be reproduced, stored in a retrieval system or transmitted in any form or by any means – electronic, photocopying, recording or otherwise – without prior written permission from BSI. Details and advice can be obtained from the Copyright & Licensing Department.

Useful Contacts:

Customer Services

Tel: +44 845 086 9001

Email (orders): orders@bsigroup.com

Email (enquiries): cservices@bsigroup.com

Subscriptions

Tel: +44 845 086 9001

Email: subscriptions@bsigroup.com

Knowledge Centre

Tel: +44 20 8996 7004

Email: knowledgecentre@bsigroup.com

Copyright & Licensing

Tel: +44 20 8996 7070

Email: copyright@bsigroup.com



...making excellence a habit.™