

BS ISO 1328-1:2013



BSI Standards Publication

# Cylindrical gears — ISO system of flank tolerance classification

Part 1: Definitions and allowable values of deviations relevant to flanks of gear teeth

**bsi.**

...making excellence a habit.™

**National foreword**

This British Standard is the UK implementation of ISO 1328-1:2013.

The UK participation in its preparation was entrusted to Technical Committee MCE/5/-/2, Gear accuracy.

A list of organizations represented on this committee can be obtained on request to its secretary.

This publication does not purport to include all the necessary provisions of a contract. Users are responsible for its correct application.

© The British Standards Institution 2013.  
Published by BSI Standards Limited 2013

ISBN 978 0 580 71815 1  
ICS 21.200

**Compliance with a British Standard cannot confer immunity from legal obligations.**

This British Standard was published under the authority of the Standards Policy and Strategy Committee on 30 September 2013.

**Amendments/corrigenda issued since publication**

| Date | Text affected |
|------|---------------|
|------|---------------|

---

---

---

**Cylindrical gears — ISO system of  
flank tolerance classification —**

Part 1:  
**Definitions and allowable values of  
deviations relevant to flanks of gear  
teeth**

*Engrenages cylindriques — Système ISO de classification des  
tolérances sur flancs —*

*Partie 1: Définitions et valeurs admissibles des écarts pour les flancs  
de la denture*





**COPYRIGHT PROTECTED DOCUMENT**

© ISO 2013

All rights reserved. Unless otherwise specified, no part of this publication may be reproduced or utilized otherwise in any form or by any means, electronic or mechanical, including photocopying, or posting on the internet or an intranet, without prior written permission. Permission can be requested from either ISO at the address below or ISO's member body in the country of the requester.

ISO copyright office  
Case postale 56 • CH-1211 Geneva 20  
Tel. + 41 22 749 01 11  
Fax + 41 22 749 09 47  
E-mail [copyright@iso.org](mailto:copyright@iso.org)  
Web [www.iso.org](http://www.iso.org)

Published in Switzerland

# Contents

|  | Page      |
|--|-----------|
| <b>Foreword</b> .....  | <b>iv</b> |
| <b>Introduction</b> .....  | <b>v</b>  |
| <b>1 Scope</b> .....   | <b>1</b>  |
| <b>2 Normative references</b> .....  | <b>2</b>  |
| <b>3 Terms, definitions and symbols</b> .....  | <b>2</b>  |
| 3.1 Fundamental terms and symbols.....   | 2         |
| 3.2 General dimensions.....  | 6         |
| 3.3 Pitch deviations.....  | 9         |
| 3.4 Profile deviations.....  | 10        |
| 3.5 Helix deviations.....  | 14        |
| <b>4 Application of the ISO flank tolerance classification system</b> .....  | <b>17</b> |
| 4.1 General.....   | 17        |
| 4.2 Geometrical parameters to be verified.....   | 17        |
| 4.3 Equipment verification and uncertainty.....  | 19        |
| 4.4 Considerations for elemental measurements.....   | 19        |
| 4.5 Specification of gear flank tolerance requirements.....  | 24        |
| 4.6 Acceptance and evaluation criteria.....  | 25        |
| 4.7 Presentation of data.....  | 25        |
| <b>5 Tolerance values</b> .....  | <b>25</b> |
| 5.1 General.....   | 25        |
| 5.2 Use of formulae.....   | 26        |
| 5.3 Tolerance formulae.....  | 26        |
| <b>Annex A (normative) Zone-based tolerance evaluation</b> .....   | <b>28</b> |
| <b>Annex B (normative) Evaluation of profile and helix deviations using the second order analysis method</b> ..... | <b>32</b> |
| <b>Annex C (informative) Profile and helix data filtering</b> .....  | <b>35</b> |
| <b>Annex D (informative) Sector pitch deviation</b> .....  | <b>37</b> |
| <b>Annex E (normative) Allowable values of runout</b> .....  | <b>40</b> |
| <b>Annex F (informative) Single flank composite testing</b> .....  | <b>43</b> |
| <b>Annex G (informative) Adjacent pitch difference, <math>f_u</math></b> .....                                     | <b>48</b> |
| <b>Bibliography</b> .....  | <b>50</b> |

## Foreword

ISO (the International Organization for Standardization) is a worldwide federation of national standards bodies (ISO member bodies). The work of preparing International Standards is normally carried out through ISO technical committees. Each member body interested in a subject for which a technical committee has been established has the right to be represented on that committee. International organizations, governmental and non-governmental, in liaison with ISO, also take part in the work. ISO collaborates closely with the International Electrotechnical Commission (IEC) on all matters of electrotechnical standardization.

International Standards are drafted in accordance with the rules given in the ISO/IEC Directives, Part 2.

The main task of technical committees is to prepare International Standards. Draft International Standards adopted by the technical committees are circulated to the member bodies for voting. Publication as an International Standard requires approval by at least 75 % of the member bodies casting a vote.

Attention is drawn to the possibility that some of the elements of this document may be the subject of patent rights. ISO shall not be held responsible for identifying any or all such patent rights.

ISO 1328-1 was prepared by Technical Committee ISO/TC 60, *Gears*.

This second edition cancels and replaces the first edition (ISO 1328-1:1995), which has been technically revised. In particular, the following are the major changes:

- the scope of applicability has been expanded;
- revisions have been made to the formulae which define the flank tolerances;
- annexes have been added to describe additional methods for analysis of modified profiles and helices;
- the evaluation of runout, previously handled in ISO 1328-2, has been brought back into this part of ISO 1328.

ISO 1328 consists of the following parts, under the general title *Cylindrical gears — ISO system of flank tolerance classification*:

- *Part 1: Definitions and allowable values of deviations relevant to flanks of gear teeth*
- *Part 2: Definitions and allowable values of deviations relevant to radial composite deviations and runout information<sup>1)</sup>*

---

1) It is intended that, upon revision, the main element of the title of Part 2 will be aligned with the main element of the title of Part 1.

## Introduction

ISO 1328:1975 (third edition, withdrawn) included definitions and allowable values of gear element deviations, along with advice on appropriate inspection methods.

The first edition of this part of ISO 1328 retained the definitions and allowable values for gear flank deviations (single pitch, cumulative pitch, total cumulative pitch, total profile and total helix), while the advice on appropriate inspection methods was given in ISO/TR 10064-1 (listed in [Clause 2](#)).





# Cylindrical gears — ISO system of flank tolerance classification —

## Part 1:

## Definitions and allowable values of deviations relevant to flanks of gear teeth

**IMPORTANT** — It is strongly recommended that any user of this part of ISO 1328 be very familiar with the methods and procedures outlined in ISO/TR 10064-1. Use of techniques other than those of ISO/TR 10064-1 combined with the limits described in this part of ISO 1328 might not be suitable.

**CAUTION** — The use of the flank tolerance classes for the determination of gear performance requires extensive experience with specific applications. Users of this part of ISO 1328 are cautioned against the direct application of tolerance values for unassembled (loose) gears to a projected performance of an assembly using these gears.

### 1 Scope

This part of ISO 1328 establishes a tolerance classification system relevant to manufacturing and conformity assessment of tooth flanks of individual cylindrical involute gears. It specifies definitions for gear flank tolerance terms, the structure of the flank tolerance class system, and allowable values.

This part of ISO 1328 provides the gear manufacturer and the gear buyer with a mutually advantageous reference for uniform tolerances. Eleven flank tolerance classes are defined, numbered 1 to 11, in order of increasing tolerance. Formulae for tolerances are provided in [5.3](#). These tolerances are applicable to the following ranges:

$$5 \leq z \leq 1\,000$$

$$5 \text{ mm} \leq d \leq 15\,000 \text{ mm}$$

$$0,5 \text{ mm} \leq m_n \leq 70 \text{ mm}$$

$$4 \text{ mm} \leq b \leq 1\,200 \text{ mm}$$

$$\beta \leq 45^\circ$$

where

$d$  is the reference diameter;

$m_n$  is the normal module;

$b$  is the facewidth (axial);

$z$  is the number of teeth;

$\beta$  is the helix angle.

See [Clause 4](#) for required and optional measuring methods.

Gear design is beyond the scope of this part of ISO 1328.

Surface texture is not considered in this part of ISO 1328. For additional information on surface texture, see ISO/TR 10064-4.

## 2 Normative references

The following documents, in whole or in part, are normatively referenced in this document and are indispensable to its application. For dated references, only the edition cited applies. For undated references, the latest edition of the referenced document (including any amendments) applies.

ISO 701, *International gear notation — Symbols for geometrical data*

ISO 1122-1, *Vocabulary of gear terms — Part 1: Definitions related to geometry*

ISO 1328-2, *Cylindrical gears — ISO system of accuracy — Part 2: Definitions and allowable values of deviations relevant to radial composite deviations and runout information*

ISO/TR 10064-1, *Code of inspection practice — Part 1: Inspection of corresponding flanks of gear teeth*

ISO/TS 16610-1, *Geometrical product specifications (GPS) — Filtration — Part 1: Overview and basic concepts*

ISO 16610-21, *Geometrical product specifications (GPS) — Filtration — Part 21: Linear profile filters: Gaussian filters*

ISO 21771, *Gears — Cylindrical involute gears and gear pairs — Concepts and geometry*

## 3 Terms, definitions and symbols

### 3.1 Fundamental terms and symbols

For the purposes of this part of ISO 1328, the following terms, definitions and symbols apply.

NOTE 1 For other definitions of geometric terms related to gearing, see ISO 701, ISO 1122-1 and ISO 21771.

NOTE 2 Some of the symbols and terminology contained in this part of ISO 1328 might differ from those used in other documents and International Standards.

NOTE 3 The terminology and symbols used in this part of ISO 1328 are listed, in alphabetical order, by term in [Table 1](#), and in alphabetical order, by symbol in [Table 2](#). The text of terms used in [Table 1](#) has been adjusted to form groups of logical terms. Subscript “T” is used for tolerance values.

**Table 1 — Terms, listed in alphabetical order, with symbols**

| Term  | Symbol         | Unit          |
|---|----------------|---------------|
| Active tip diameter                         | $d_{Na}$       | mm            |
| Active tip diameter point on line of action | $N_a$          | –             |
| Adjacent pitch difference                   | $f_u$          | $\mu\text{m}$ |
| Adjacent pitch difference tolerance         | $f_{uT}$       | $\mu\text{m}$ |
| Adjacent pitch difference, individual       | $f_{ui}$       | $\mu\text{m}$ |
| Amount of root relief                       | $C_{\alpha f}$ | $\mu\text{m}$ |
| Amount of tip relief                        | $C_{\alpha a}$ | $\mu\text{m}$ |
| Base diameter                               | $d_b$          | mm            |
| Contact pattern evaluation                  | $c_p$          | –             |
| Contact point tangent at base circle        | $T$            | –             |

Table 1 (continued)

| Term   | Symbol                      | Unit          |
|--|-----------------------------|---------------|
| Cumulative pitch deviation (index deviation), individual | $F_{pi}$                    | $\mu\text{m}$ |
| Cumulative pitch deviation (index deviation), total      | $F_p$                       | $\mu\text{m}$ |
| Cumulative pitch (index) tolerance, total                | $F_{pT}$                    | $\mu\text{m}$ |
| Facewidth (axial)  | $b$                         | mm            |
| Flank tolerance class                                    | $A$                         | -             |
| Helix angle  | $\beta$                     | deg           |
| Helix deviation, total                                   | $F_\beta$                   | $\mu\text{m}$ |
| Helix evaluation length                                  | $L_\beta$                   | mm            |
| Helix form deviation                                     | $f_{f\beta}$                | $\mu\text{m}$ |
| Helix form filter cutoff                                 | $\lambda_\beta$             | mm            |
| Helix form tolerance                                     | $f_{f\beta T}$              | $\mu\text{m}$ |
| Helix slope deviation                                    | $f_{H\beta}$                | $\mu\text{m}$ |
| Helix slope tolerance                                    | $f_{H\beta T}$              | $\mu\text{m}$ |
| Helix tolerance, total                                   | $F_{\beta T}$               | $\mu\text{m}$ |
| Individual radial measurement                            | $r_i$                       | $\mu\text{m}$ |
| Length of path of contact                                | $g_\alpha$                  | mm            |
| Maximum length of tip relief                             | $L_{C\alpha a, \text{max}}$ | mm            |
| Maximum length of root relief                            | $L_{C\alpha f, \text{max}}$ | mm            |
| Measurement diameter                                     | $d_M$                       | mm            |
| Middle profile zone                                      | $L_{\alpha m}$              | -             |
| Minimum length of tip relief                             | $L_{C\alpha a, \text{min}}$ | mm            |
| Minimum length of root relief                            | $L_{C\alpha f, \text{min}}$ | mm            |
| Normal module  | $m_n$                       | mm            |
| Number of teeth  | $z$                         | -             |
| Number of pitches in a sector                            | $k$                         | -             |
| Pitch, transverse circular on measurement diameter       | $p_{tM}$                    | mm            |
| Pitch point  | $C$                         | -             |
| Pitch span deviation                                     | $F_{pSk}$                   | $\mu\text{m}$ |
| Profile control diameter                                 | $d_{Cf}$                    | mm            |
| Profile deviation, total                                 | $F_\alpha$                  | $\mu\text{m}$ |
| Profile evaluation length                                | $L_\alpha$                  | mm            |
| Profile form deviation                                   | $f_{f\alpha}$               | $\mu\text{m}$ |
| Profile form filter cutoff                               | $\lambda_\alpha$            | mm            |
| Profile form tolerance                                   | $f_{f\alpha T}$             | $\mu\text{m}$ |
| Profile slope deviation                                  | $f_{H\alpha}$               | $\mu\text{m}$ |
| Profile slope tolerance                                  | $f_{H\alpha T}$             | $\mu\text{m}$ |
| Profile tolerance, total                                 | $F_{\alpha T}$              | $\mu\text{m}$ |
| Radial composite deviation, tooth-to-tooth <sup>a</sup>  | $f_i''$                     | $\mu\text{m}$ |
| Radial composite deviation, total <sup>a</sup>           | $F_i''$                     | $\mu\text{m}$ |

**Table 1** (continued)

| Term   | Symbol          | Unit          |
|--|-----------------|---------------|
| Reference diameter                               | $d$             | mm            |
| Root form diameter                               | $d_{Ff}$        | mm            |
| Root relief zone                                 | $L_{C\alpha f}$ | –             |
| Runout   | $F_R$           | $\mu\text{m}$ |
| Sector pitch deviation                           | $F_{pk}$        | $\mu\text{m}$ |
| Sector pitch tolerance                           | $F_{pkT}$       | $\mu\text{m}$ |
| Single flank composite deviation, total          | $F_{is}$        | $\mu\text{m}$ |
| Single flank composite tolerance, total          | $F_{isT}$       | $\mu\text{m}$ |
| Single flank composite deviation, tooth-to-tooth | $f_{is}$        | $\mu\text{m}$ |
| Single flank composite tolerance, tooth-to-tooth | $f_{isT}$       | $\mu\text{m}$ |
| Single pitch deviation                           | $f_p$           | $\mu\text{m}$ |
| Single pitch deviation (individual)              | $f_{pi}$        | $\mu\text{m}$ |
| Single pitch tolerance                           | $f_{pT}$        | $\mu\text{m}$ |
| Start of active profile diameter                 | $d_{Nf}$        | mm            |
| Start of active profile point on line of action  | $N_f$           | –             |
| Tip corner chamfer                               | $h_k$           | mm            |
| Tip diameter                                     | $d_a$           | mm            |
| Tip form diameter                                | $d_{Fa}$        | mm            |
| Tip relief zone                                  | $L_{C\alpha a}$ | –             |
| Tooth thickness                                  | $s$             | mm            |
| Working pitch diameter                           | $d_w$           | mm            |
| Working transverse pressure angle                | $\alpha_{wt}$   | deg           |
| a Symbols given in ISO 1328-2.                   |                 |               |

**Table 2** — Symbols, listed in alphabetical order, with terms

| Symbol         | Term                       | Unit          |
|----------------|----------------------------|---------------|
| $A$            | Flank tolerance class      | –             |
| $b$            | Facewidth (axial)          | mm            |
| $C$            | Pitch point                | –             |
| $C_{\alpha a}$ | Amount of tip relief       | $\mu\text{m}$ |
| $C_{\alpha f}$ | Amount of root relief      | $\mu\text{m}$ |
| $c_p$          | Contact pattern evaluation | –             |
| $d$            | Reference diameter         | mm            |
| $d_a$          | Tip diameter               | mm            |
| $d_b$          | Base diameter              | mm            |
| $d_{Cf}$       | Profile control diameter   | mm            |
| $d_{Fa}$       | Tip form diameter          | mm            |
| $d_{Ff}$       | Root form diameter         | mm            |
| $d_M$          | Measurement diameter       | mm            |

Table 2 (continued)

| Symbol          | Term   | Unit |
|-----------------|--|------|
| $d_{Na}$        | Active tip diameter                                      | mm   |
| $d_{Nf}$        | Start of active profile diameter                         | mm   |
| $d_w$           | Working pitch diameter                                   | mm   |
| $F_i''$         | Radial composite deviation, total <sup>a</sup>           | μm   |
| $F_{is}$        | Single flank composite deviation, total                  | μm   |
| $F_{isT}$       | Single flank composite tolerance, total                  | μm   |
| $F_p$           | Cumulative pitch deviation (index deviation), total      | μm   |
| $F_{pi}$        | Cumulative pitch deviation (index deviation), individual | μm   |
| $F_{pk}$        | Sector pitch deviation                                   | μm   |
| $F_{pkT}$       | Sector pitch tolerance                                   | μm   |
| $F_{pT}$        | Cumulative pitch (index) tolerance, total                | μm   |
| $F_{pSk}$       | Pitch span deviation                                     | μm   |
| $F_r$           | Runout   | μm   |
| $F_\alpha$      | Profile deviation, total                                 | μm   |
| $F_{\alpha T}$  | Profile tolerance, total                                 | μm   |
| $F_\beta$       | Helix deviation, total                                   | μm   |
| $F_{\beta T}$   | Helix tolerance, total                                   | μm   |
| $f_{f\alpha}$   | Profile form deviation                                   | μm   |
| $f_{f\alpha T}$ | Profile form tolerance                                   | μm   |
| $f_{f\beta}$    | Helix form deviation                                     | μm   |
| $f_{f\beta T}$  | Helix form tolerance                                     | μm   |
| $f_{H\alpha}$   | Profile slope deviation                                  | μm   |
| $f_{H\alpha T}$ | Profile slope tolerance                                  | μm   |
| $f_{H\beta}$    | Helix slope deviation                                    | μm   |
| $f_{H\beta T}$  | Helix slope tolerance                                    | μm   |
| $f_i''$         | Radial composite deviation, tooth-to-tooth <sup>a</sup>  | μm   |
| $f_{is}$        | Single flank composite deviation, tooth-to-tooth         | μm   |
| $f_{isT}$       | Single flank composite tolerance, tooth-to-tooth         | μm   |
| $f_p$           | Single pitch deviation                                   | μm   |
| $f_{pi}$        | Single pitch deviation (individual)                      | μm   |
| $f_{pT}$        | Single pitch tolerance                                   | μm   |
| $f_u$           | Adjacent pitch difference                                | μm   |
| $f_{ui}$        | Adjacent pitch difference, individual                    | μm   |
| $f_{uT}$        | Adjacent pitch difference tolerance                      | μm   |
| $g_\alpha$      | Length of path of contact                                | mm   |
| $h_k$           | Tip corner chamfer                                       | mm   |
| $k$             | Number of pitches in a sector                            | -    |
| $L_{\alpha m}$  | Middle profile zone                                      | -    |
| $L_{C\alpha a}$ | Tip relief zone  | -    |

**Table 2** (continued)

| Symbol                | Term   | Unit          |
|-----------------------|--|---------------|
| $L_{C\alpha f}$       | Root relief zone                                   | –             |
| $L_{c\alpha a, \max}$ | Maximum length of tip relief                       | mm            |
| $L_{c\alpha a, \min}$ | Minimum length of tip relief                       | mm            |
| $L_{c\alpha f, \max}$ | Maximum length of root relief                      | mm            |
| $L_{c\alpha f, \min}$ | Minimum length of root relief                      | mm            |
| $L_{\alpha}$          | Profile evaluation length                          | mm            |
| $L_{\beta}$           | Helix evaluation length                            | mm            |
| $m_n$                 | Normal module                                      | mm            |
| $N_a$                 | Active tip diameter point on line of action        | –             |
| $N_f$                 | Start of active profile point on line of action    | –             |
| $p_{tM}$              | Pitch, transverse circular on measurement diameter | mm            |
| $r_i$                 | Individual radial measurement                      | $\mu\text{m}$ |
| $s$                   | Tooth thickness                                    | mm            |
| $T$                   | Contact point at tangent at base circle            | –             |
| $z$                   | Number of teeth                                    | –             |
| $\alpha_{wt}$         | Working transverse pressure angle                  | deg           |
| $\beta$               | Helix angle  | deg           |
| $\lambda_{\alpha}$    | Profile form filter cutoff                         | mm            |
| $\lambda_{\beta}$     | Helix form filter cutoff                           | mm            |

<sup>a</sup> Symbols given in ISO 1328-2.

## 3.2 General dimensions

### 3.2.1 reference diameter

$d$   
diameter of reference circle

Note 1 to entry: The reference diameter is used to calculate values of tolerances.

Note 2 to entry: See ISO 21771:2007, 4.2.4.

### 3.2.2 measurement diameter

$d_M$   
diameter of the circle concentric with the *datum axis* (3.2.7) where the probe is in contact with the tooth flanks during the measurement of helix, pitch or tooth thickness deviations

Note 1 to entry: The measurement diameter is usually near the middle of the flank.

Note 2 to entry: See ISO/TR 10064-3.

### 3.2.3 profile form filter cutoff

$\lambda_{\alpha}$   
wavelength where 50 % of the amplitude of the involute profile measurement data is transmitted as a result of the Gaussian low-pass filter, thereby including only longer wavelength deviations

Note 1 to entry: See 4.4.6 and Annex C.

### 3.2.4

#### helix form filter cutoff

$\lambda_\beta$

wavelength where 50 % of the amplitude of the helix measurement data is transmitted as a result of the Gaussian low-pass filter, thereby including only longer wavelength deviations

Note 1 to entry: See [4.4.6](#) and [Annex C](#).

### 3.2.5

#### roll path length

length of roll

linear distance along a base tangent line from its contact with the base circle to the given point on the involute profile in the transverse plane

Note 1 to entry: Roll path length is an alternative to roll angle for specification of selected diameter positions on an involute profile.

Note 2 to entry: See [Figure 1](#) and ISO 21771:2007, 4.3.8.

### 3.2.6

#### length of path of contact

$g_\alpha$

*roll path length* ([3.2.5](#)) from the start of active profile,  $d_{Nf}$ , to the tip form diameter,  $d_{Fa}$ , or to the point where contact stops due to undercut on the mating part (end of active profile)

### 3.2.7

#### datum axis

axis to which the gear details, and in particular the pitch, profile and helix tolerances, are defined

Note 1 to entry: The datum axis of the gear is defined by the datum surfaces.

Note 2 to entry: See ISO/TR 10064-3.

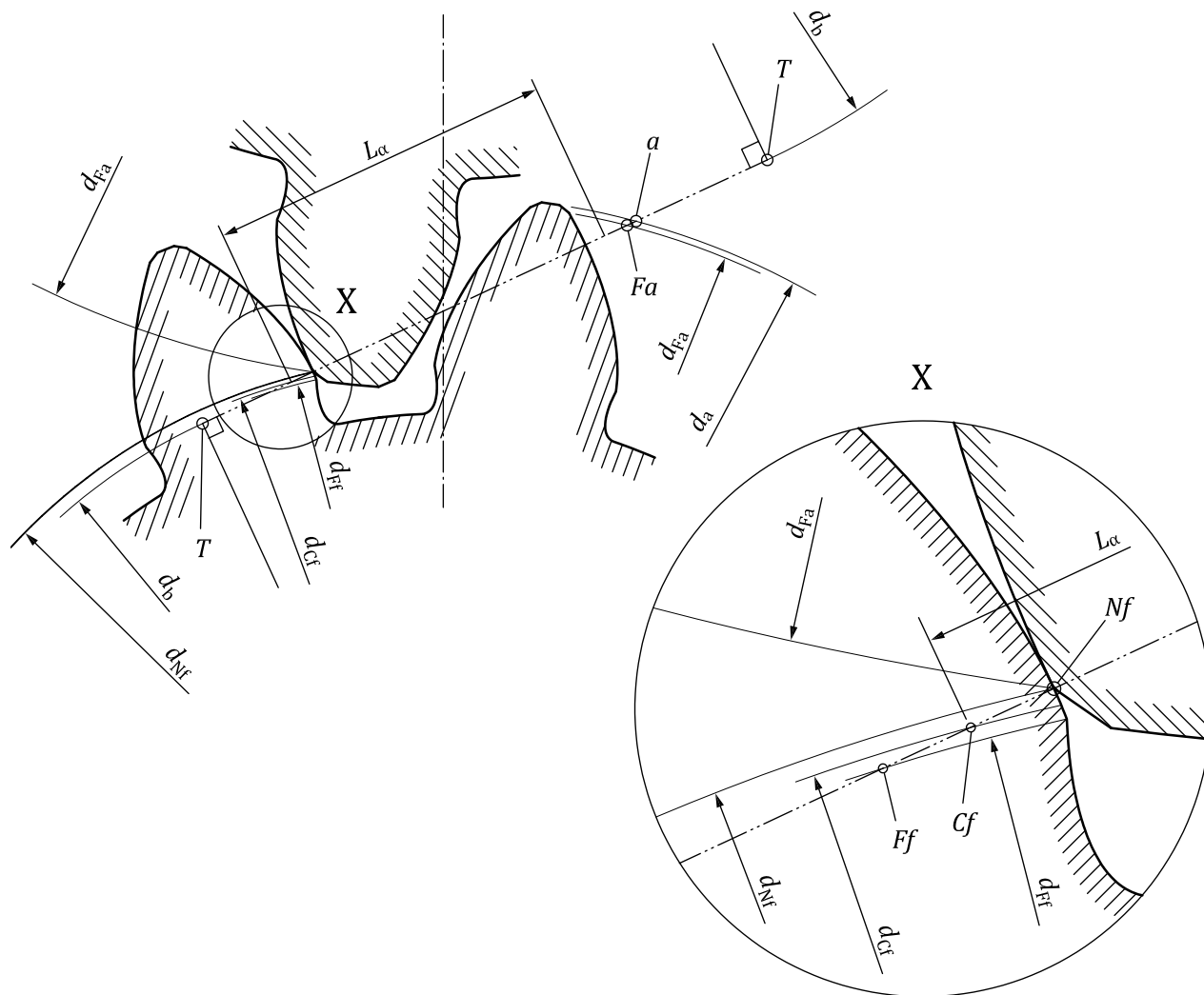

**Key**

$L_\alpha$  evaluation length

Points on line of action

a tip

Cf profile control

Fa tip form

Ff root form

Nf start of active profile

T tangency to base circle

— · · · — line of action

Diameters

$d_a$  tip

$d_b$  base

$d_{Cf}$  profile control

$d_{Fa}$  tip form, where tip break starts

$d_{Ff}$  root form, where involute starts

$d_{Nf}$  start of active profile

NOTE Diameters on mating gear have the same symbols, but different values.

**Figure 1 — Diameters and roll path length for an external gear pair**



### 3.3 Pitch deviations

#### 3.3.1 individual single pitch deviation

$f_{pi}$   
algebraic difference between the actual pitch and the corresponding theoretical pitch in the transverse plane on the measurement circle of the gear

Note 1 to entry: It corresponds to the displacement of any tooth flank from its theoretical position relative to the corresponding flank of an adjacent tooth.

Note 2 to entry: For the left flanks, as well as for the right flanks, there are as many values of  $f_{pi}$  as there are teeth.

Note 3 to entry: See [Figure 2](#).

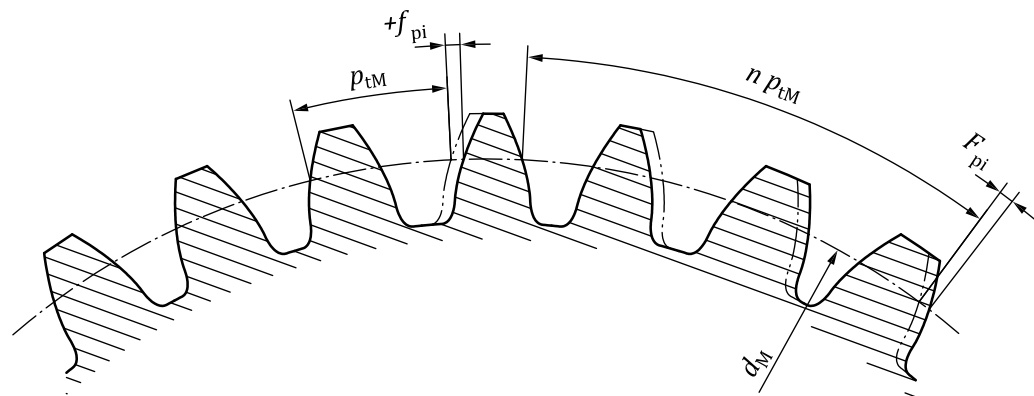

#### Key

— · — · — · — · — theoretical  
————— actual

NOTE  $p_{tM} = \pi d_M/z$ .

Figure 2 — Pitch deviations

#### 3.3.2 single pitch deviation

$f_p$   
maximum absolute value of all the *individual single pitch deviations* (3.3.1) observed

Note 1 to entry:  $f_p = \max |f_{pi}|$ .

#### 3.3.3 individual cumulative pitch deviation

individual index deviation

$F_{pi}$   
algebraic difference, over a sector of  $n$  adjacent pitches, between the length and the theoretical length of the relevant arc

Note 1 to entry:  $n$  varies from 1 to  $z$ ; for the left flanks, as well as the right flanks, there are as many values of  $F_{pi}$  as there are teeth.

Note 2 to entry: In theory, it is equal to the algebraic sum of the individual single pitch deviations (3.3.1) of the same  $n$  pitches. It corresponds to the displacement of any tooth flank from its theoretical position, relative to a datum tooth flank.

Note 3 to entry: See [Figure 2](#) and [Annex D](#).

**3.3.4 total cumulative pitch deviation**

total index deviation

$F_p$   
 largest algebraic difference between the *individual cumulative pitch deviation* (3.3.3) values for a specified flank obtained for all the teeth of a gear

Note 1 to entry:  $F_p = \max. F_{pi} - \min. F_{pi}$ .

**3.4 Profile deviations**

**3.4.1 Profile deviations — General**

**3.4.1.1 profile control diameter**

start of profile evaluation diameter

$d_{cf}$   
 specified diameter beyond which the tooth profile is required to conform to the specified *design profile* (3.4.2.1)

Note 1 to entry: If not specified, the start of active profile diameter,  $d_{Nf}$ , is used as the profile control diameter, see the last paragraph of 4.5.

Note 2 to entry: See [Figures 1](#) and [3](#).

**3.4.1.2 tip form diameter**

$d_{Fa}$   
 unless otherwise specified, tip diameter minus twice the tip corner radius or chamfer

Note 1 to entry: This is the minimum specified diameter for external gears or maximum specified diameter for internal gears where the tip break (start of tip chamfer or tip corner radius) can occur.

Note 2 to entry: With direct transition between the nominal involute helicoid and the top land of the tooth, the tip corner radius is zero and the tip form diameter is equal to the tip diameter.

Note 3 to entry: See [Figures 1](#) and [3](#).

**3.4.1.3 measured profile**

portion of the tooth flank along which the probe is in contact during the profile measurement, which shall include the *profile control diameter* (3.4.1.1) and the *tip form diameter* (3.4.1.2)

Note 1 to entry: See [Figure 3](#).

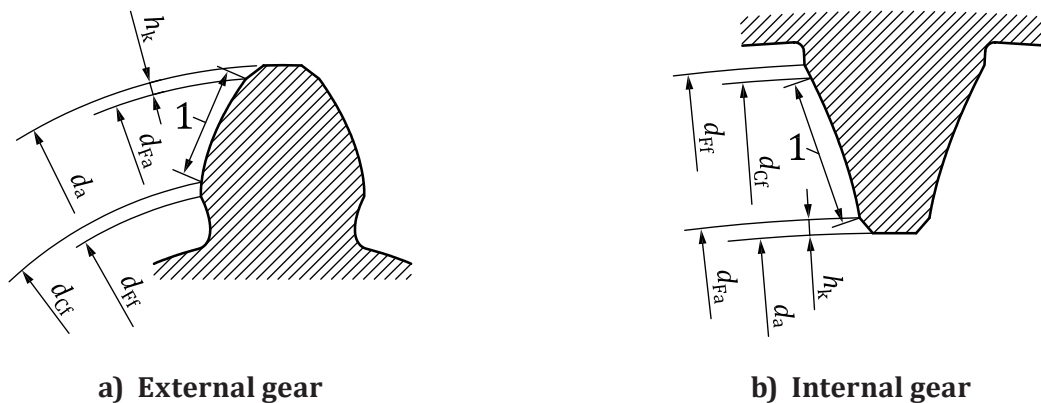

**Key**

1 measured profile

**Figure 3 — Measured profile**

**3.4.1.4**

**profile evaluation range**

section of the *measured profile* (3.4.1.3) starting at the profile control diameter (3.4.1.1),  $d_{Cf}$ , and, unless otherwise specified, ending at 95 % of the length to the tip form diameter (3.4.1.2),  $d_{Fa}$

Note 1 to entry: See [Figures 4 to 8](#), 4.4.8 and ISO 21771.

**3.4.1.5**

**profile evaluation length**

$L_\alpha$

roll path length (3.2.5) of the *profile evaluation range* (3.4.1.4) in a transverse plane

Note 1 to entry: See [Figure 1](#).

**3.4.1.6**

**profile deviation**

amount by which a *measured profile* (3.4.1.3) deviates from the *design profile* (3.4.2.1)

Note 1 to entry: See [Figures 4 to 8](#).

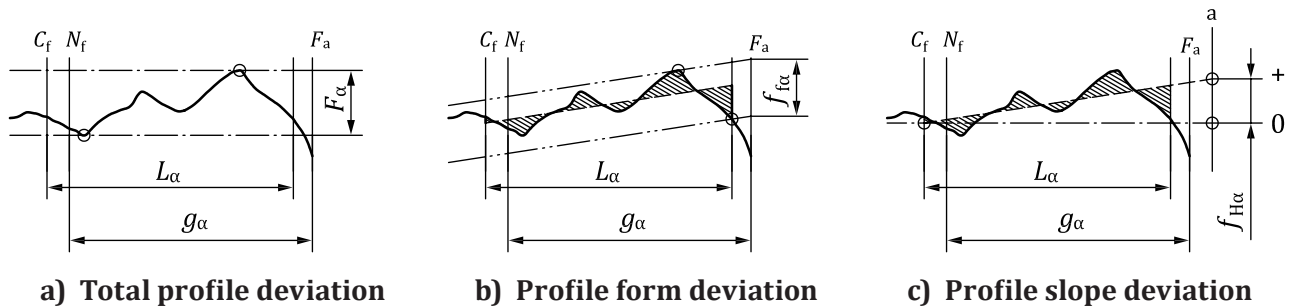

**Key**

- |       |                                |       |                                  |
|-------|--------------------------------|-------|----------------------------------|
| ————— | measured profile               | ○     | Points on line of action         |
| ----- | facsimile of design profile    | $C_f$ | profile control                  |
| ----- | mean profile line              | $N_f$ | start of active profile          |
| ----- | facsimile of mean profile line | $F_a$ | tip form, where tip break starts |
|       |                                | a     | tip                              |

**Figure 4 — Profile deviations with unmodified involute**

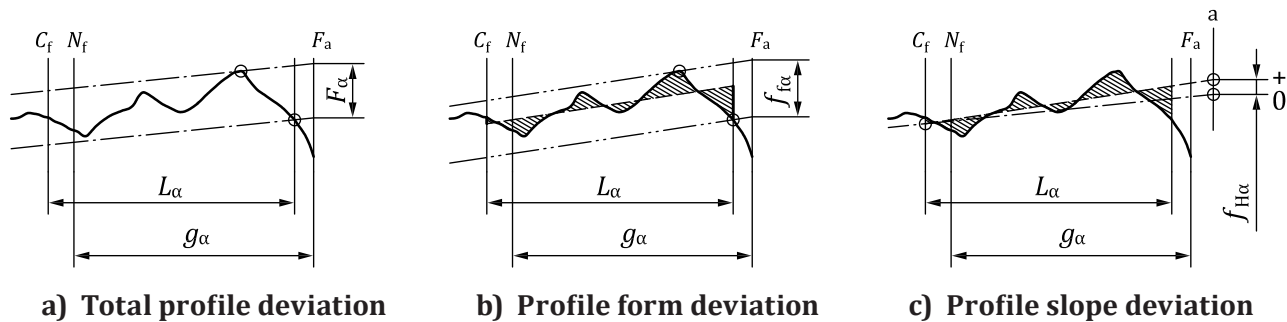

See the key to [Figure 4](#).

Figure 5 — Profile deviations with pressure angle modified

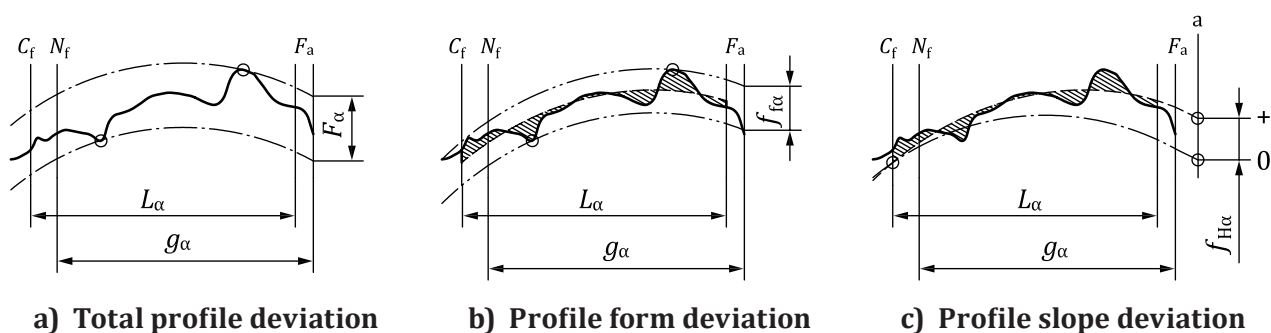

See the key to [Figure 4](#).

Figure 6 — Profile deviations with profile crowning modification

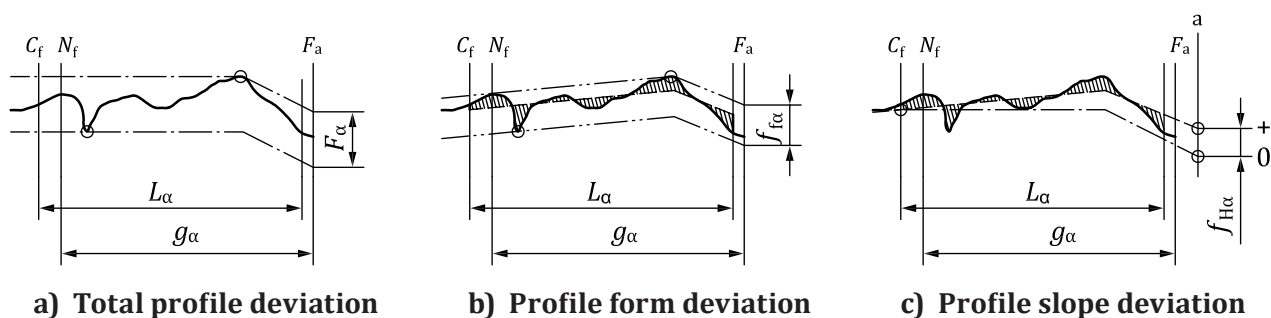

See the key to [Figure 4](#).

Figure 7 — Profile deviations with profile modified with tip relief

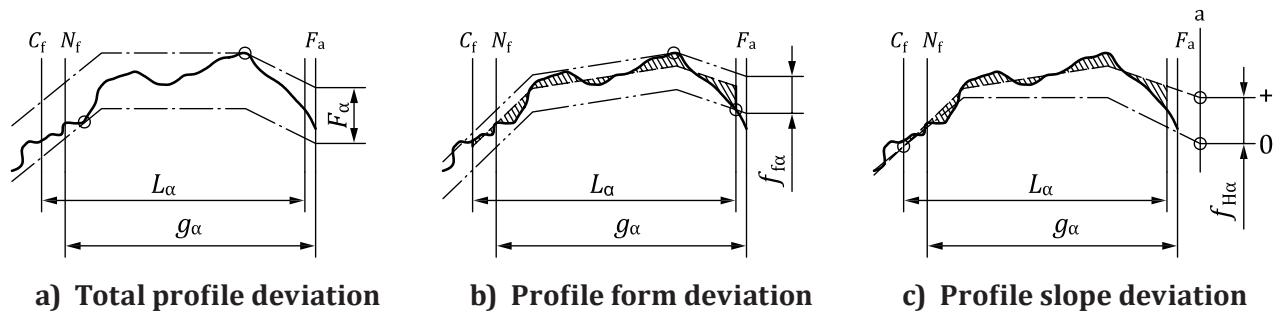

See the key to [Figure 4](#).

**Figure 8 — Profile deviations with profile modified with tip and root relief**

### 3.4.2 Analysis of profile deviations

#### 3.4.2.1 design profile

profile specified by the designer in a diagram where one axis has modifications from a pure involute and the other axis has the roll length along the tangent to the base circle

Note 1 to entry: When the design profile is not specified, it is an unmodified involute and appears as a straight line. In [Figures 4](#) to [8](#), the design profiles are shown as broken-chain (dotted) lines.

Note 2 to entry: See [Figures 4](#) to [8](#).

#### 3.4.2.2 mean profile line

line (or curve) that represents the shape of the *design profile* ([3.4.2.1](#)), but aligned with the measured trace over the *profile evaluation range* ([3.4.1.4](#))

Note 1 to entry: See [4.4.8.2](#) for the method to be used.

#### 3.4.2.3 profile deviation, total

$F_\alpha$   
distance between two facsimiles of the *design profile* ([3.4.2.1](#)) which enclose the *measured profile* ([3.4.1.3](#)) over the *profile evaluation range* ([3.4.1.4](#))

Note 1 to entry: The facsimiles of the design profile are kept parallel to the design profile.

Note 2 to entry: See [Figures 4](#) to [8](#) and [4.4.8.2](#).

#### 3.4.2.4 profile form deviation

$f_{f\alpha}$   
distance between two facsimiles of the *mean profile line* ([3.4.2.2](#)) which enclose the *measured profile* ([3.4.1.3](#)) over the *profile evaluation range* ([3.4.1.4](#))

Note 1 to entry: The facsimiles of the mean profile line are kept parallel to the mean profile line.

Note 2 to entry: See [Figures 4](#) to [8](#) and [4.4.8.2](#).

### 3.4.2.5 profile slope deviation

$f_{H\alpha}$   
distance between two facsimiles of the *design profile* (3.4.2.1) which intersect the extrapolated *mean profile line* (3.4.2.2) at the *profile control diameter* (3.4.1.1),  $d_{Cf}$ , and the tip diameter,  $d_a$

Note 1 to entry: The facsimiles of the design profile are kept parallel to the design profile.

Note 2 to entry: See [Figures 4 to 8](#).

## 3.5 Helix deviations

### 3.5.1 Helix deviations — General

#### 3.5.1.1 measured helix

full flank between the end faces or, if present, the start of end chamfers, rounds, or other modification intended to exclude that portion of the tooth from engagement, along which the probe is in contact during the helix measurement

#### 3.5.1.2 helix evaluation range

flank area between the end faces or, if present, the start of end chamfers, rounds, or other modification intended to exclude that portion of the tooth from engagement, that is, unless otherwise specified, shortened in the axial direction at each end by the smaller of 5 % of the facewidth or the length equal to one module

Note 1 to entry: It is the responsibility of the gear designer to ensure that the helix evaluation range is adequate for the application.

Note 2 to entry: See [4.4.8.4](#).

#### 3.5.1.3 helix evaluation length

$L_\beta$   
axial length of the *helix evaluation range* (3.5.1.2)

#### 3.5.1.4 helix deviation

amount by which a *measured helix* (3.5.1.1) deviates from the *design helix* (3.5.2.1)

Note 1 to entry: See [Figures 9 to 13](#).

### 3.5.2 Analysis of helix deviations

#### 3.5.2.1 design helix

helix specified by the designer in a diagram where one axis has modifications from a pure helix and the other axis has the facewidth

Note 1 to entry: When not specified, it is an unmodified helix.

Note 2 to entry: See [Figures 9 to 13](#).

#### 3.5.2.2 mean helix line

line (or curve) that represents the shape of the *design helix* (3.5.2.1), but aligned with the measured trace

Note 1 to entry: See [4.4.8.4](#) for the method to be used.



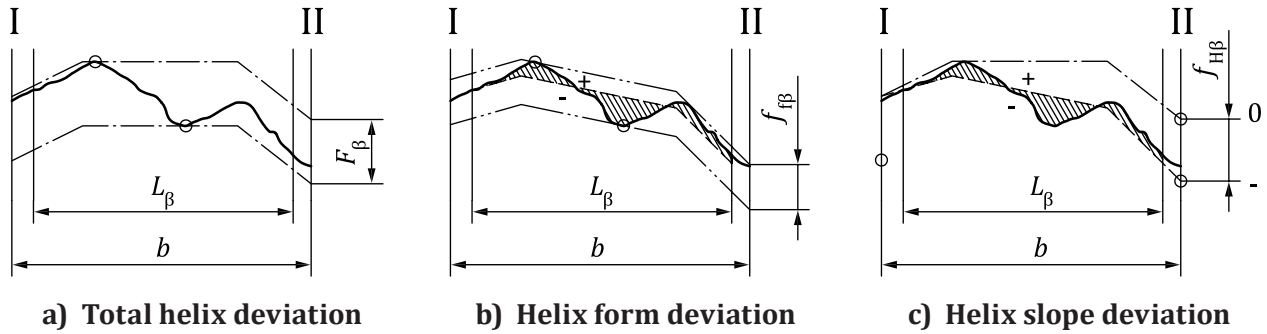

See the key to [Figure 9](#).

Figure 12 — Helix deviations with helix end relief

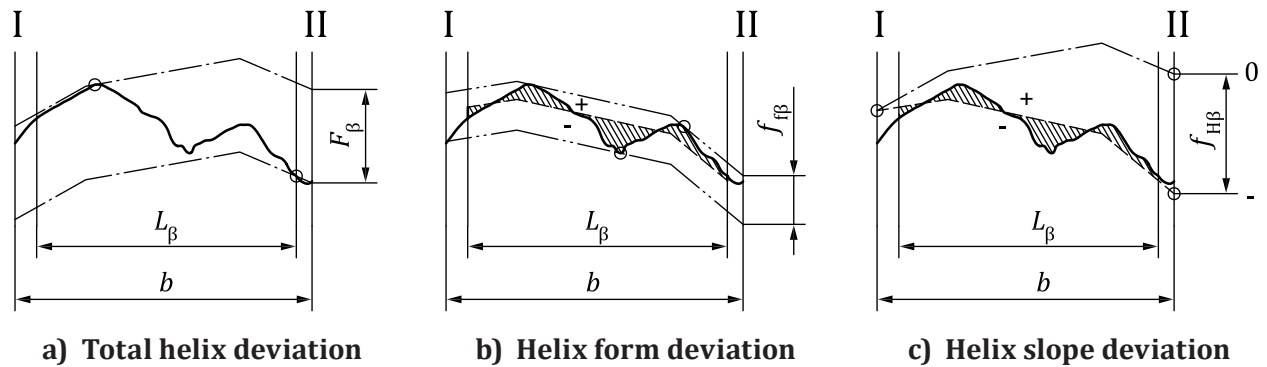

See the key to [Figure 9](#).

Figure 13 — Helix deviations with modified helix angle with end relief

### 3.5.2.3

#### helix deviation, total

$F_{\beta}$   
distance between two facsimiles of the *design helix* (3.5.2.1) which enclose the *measured helix* (3.5.1.1) over the *helix evaluation range* (3.5.1.2)

Note 1 to entry: The facsimiles of the design helix are kept parallel to the design helix.

Note 2 to entry: See [Figures 9 to 13](#) and [4.4.8.4](#).

### 3.5.2.4

#### helix form deviation

$f_{f\beta}$   
distance between two facsimiles of the *mean helix line* (3.5.2.2), which enclose the *measured helix* (3.5.1.1) over the *helix evaluation range* (3.5.1.2)

Note 1 to entry: The facsimiles of the mean helix line are kept parallel to the mean helix line.

Note 2 to entry: See [Figures 9 to 13](#) and [4.4.8.4](#).



### 3.5.2.5 helix slope deviation

$f_{H\beta}$

distance between two facsimiles of the *design helix* (3.5.2.1) which intersect the extrapolated *mean helix line* (3.5.2.2) at the end points of the facewidth,  $b$

Note 1 to entry: The facsimiles of the design helix are kept parallel to the design helix.

Note 2 to entry: See [Figures 9](#) to [13](#).

Note 3 to entry: See [4.4.8.4](#) for the method to be used.

## 4 Application of the ISO flank tolerance classification system

### 4.1 General

This part of ISO 1328 provides flank classification tolerances and recommends measuring requirements for unassembled gears.

Some design and application considerations can warrant measuring or documentation not normally available in standard manufacturing processes. Specific requirements shall be stated in the contractual documents.

No particular method of measurement or documentation is considered mandatory unless specifically agreed upon between the manufacturer and purchaser. When applications require measurements beyond those recommended in this part of ISO 1328, special measurement methods shall be negotiated prior to manufacturing the gear.

The designation as defined in [4.6.1](#) shall be used when specifying flank tolerance classes from this part of ISO 1328, since in the previous edition, the flank tolerance classes had different tolerance values.

### 4.2 Geometrical parameters to be verified

The geometrical features of a gear, listed in [Table 3](#), may be measured by a number of methods. The selection of the particular method depends on the magnitude of the tolerance, the related measurement uncertainty, the size of the gear, the production quantities, equipment available, accuracy of gear blanks, and measurement costs. Measuring methods and practices for spur and helical gears are discussed in ISO/TR 10064-1.

**Table 3 — Parameters — Locations of definitions and tolerances**

| Parameter symbol  | Measurement description                | Location of tolerance | Location of definition  |
|-------------------|--|-----------------------|-------------------------|
| <b>Elemental:</b> |  |                       |                         |
| $F_p$             | Cumulative pitch (index), total        | 5.3.2                 | 3.3.4                   |
| $f_p$             | Single pitch                           | 5.3.1                 | 3.3.2                   |
| $F_\alpha$        | Profile, total                         | 5.3.3.3               | 3.4.2.3                 |
| $f_{f\alpha}$     | Profile form                           | 5.3.3.2               | 3.4.2.4                 |
| $f_{H\alpha}$     | Profile slope                          | 5.3.3.1               | 3.4.2.5                 |
| $F_\beta$         | Helix, total                           | 5.3.4.3               | 3.5.2.3                 |
| $f_{f\beta}$      | Helix form                             | 5.3.4.2               | 3.5.2.4                 |
| $f_{H\beta}$      | Helix slope                            | 5.3.4.1               | 3.5.2.5                 |
| $F_r$             | Runout                                 | E.4                   | E.3                     |
| $F_{pk}$          | Sector pitch                           | D.5                   | D.2                     |
| $f_u$             | Adjacent pitch difference              | G.2                   | G.1.2                   |
| <b>Composite:</b> |  |                       |                         |
| $F_{is}$          | Single flank composite, total          | F.1.6                 | <a href="#">Annex F</a> |
| $f_{is}$          | Single flank composite, tooth-to-tooth | F.1.5                 | F.1.5                   |
| $c_p$             | Contact pattern (see ISO/TR 10064-4)   | –                     |                         |
| <b>Size:</b>      |  |                       |                         |
| $s$               | Tooth thickness (see ISO 21771)        | –                     |                         |

A gear that is specified to an ISO flank tolerance class shall meet all the individual tolerance requirements applicable to the particular flank tolerance class and size as noted in [Tables 4](#) and [5](#).

[Table 4](#) contains lists of the minimum set of parameters that shall be checked for compliance with this part of ISO 1328. With agreement between the manufacturer and purchaser, the alternative list may be used instead of the default list. The selection of the default or alternative list may depend on the measuring instruments available. The parameter list for a more accurate flank tolerance class may be used when evaluating gears.

Normally, the tolerances apply to both sides of the teeth. In some cases, the loaded flank may specify better accuracy than the non-loaded or minimum-loaded flank; if applicable, this information and indication of the loaded flank shall be specified on the gear engineering drawing.

**Table 4 — Parameters to be measured**

| Diameter<br>mm  | Flank tolerance class | Minimum acceptable parameters  |   |
|-----------------|-----------------------|--|---|
|                 |                       | Default parameter list   | Alternative parameter list                    |
| $d \leq 4\,000$ | 10 to 11              | $F_p, f_p, s, F_\alpha, F_\beta$   | $s, c_p^b, F_i''^a, f_i''^a$                  |
|                 | 7 to 9                | $F_p, f_p, s, F_\alpha, F_\beta$   | $s, c_p^b, F_{is}, f_{is}$                    |
|                 | 1 to 6                | $F_p, f_p, s$<br>$F_\alpha, f_{f\alpha}, f_{H\alpha}$<br>$F_\beta, f_{f\beta}, f_{H\beta}$ | $s, c_p^b, F_{is}, f_{is}$                    |
| $d > 4\,000$    | 7 to 11               | $F_p, f_p, s, F_\alpha, F_\beta$   | $F_p, f_p, s, (f_{f\beta} \text{ or } c_p^b)$ |

<sup>a</sup> In accordance with ISO 1328-2, but only when size is not a constraint.

<sup>b</sup> Contact pattern acceptance criteria and measurement practice are not specified in this part of ISO 1328, and shall be agreed upon between the manufacturer and purchaser.

Table 5 — Minimum number of measurements

| Method designator  | Typical measuring method   | Minimum number of requirements                       |
|--|--|--|
| <b>Elemental:</b><br>$F_p$ : Cumulative pitch (index), total                                 | Two probe<br>Single probe  | All teeth<br>All teeth                               |
| $f_p$ : Single pitch   | Two probe<br>Single probe  | All teeth<br>All teeth                               |
| $F_\alpha$ : Profile, total<br>$f_{i\alpha}$ : Profile form<br>$f_{H\alpha}$ : Profile slope | Profile  | Three teeth  |
| $F_\beta$ : Helix, total<br>$f_{i\beta}$ : Helix form<br>$f_{H\beta}$ : Helix slope          | Helix  | Three teeth  |
| <b>Composite:</b><br>$F_{is}$ : Single flank composite, total                                | –  | All teeth  |
| $f_{is}$ : Single flank composite, tooth-to-tooth  | –  | All teeth  |
| $c_p$ : Contact pattern  | –  | Three places   |
| <b>Sizes:</b><br>$s$ : Tooth thickness   | Chordal measurement<br>Measurement over or between pins<br>Span measurement<br>Composite action test | Three teeth<br>Two places<br>Two places<br>All teeth |

Unless otherwise specified, the manufacturer shall select:

- the measurement method to be used from among the applicable methods described in ISO/TR 10064-1 and summarized in [Table 5](#);
- the piece of measurement equipment to be used by the selected measurement method, provided it is in proper calibration;
- the individual teeth to be measured, as long as they are approximately equally spaced and meet the minimum number required by the method as summarized in [Table 5](#).

### 4.3 Equipment verification and uncertainty

In order to ensure traceability, the equipment used for the measurement of gears should be verified periodically according to standard calibration procedures, such as those in ISO 18653. The uncertainty of the measuring process should be determined.

### 4.4 Considerations for elemental measurements

#### 4.4.1 Summary of considerations

Before elemental measurement values can be compared with tolerance values, certain operational parameters of the measurement method shall be known. These include:

- datum axis;
- direction of measurement;
- direction of tolerance;
- measurement diameter;

- data filtering;
- data density;
- required measuring practices.

In some cases, measurement instruments follow the minimum requirements by default. When other conditions exist, it is required that the causes of the measurement differences be known and compensated for.

It is important to distinguish between measurement location (the measurement diameter), measurement direction, and tolerance direction.

#### 4.4.2 Datum axis

Specification of design profile, design helix and pitch requires the definition of an appropriate reference axis of rotation, called the datum axis. It is defined by specification of datum surfaces. See ISO/TR 10064-3.

The tooth geometry is determined with reference to the datum axis, so the datum axis is the reference for measurements and associated tolerances. The location and orientation of the measurement diameter circle are determined by the datum axis.

#### 4.4.3 Direction of measurement

Measurements of the shape or the position of any surface may be made in a direction normal to that surface, inclined at some angle, or along the arc of a specified circle.

Common metrology practice is to measure in a direction normal to the surface being measured. At any point on a gear tooth surface, the normal vector is oriented a) tangent to the base cylinder of the gear, and b) inclined relative to the transverse plane at the base helix angle.

It is important to understand that gear measuring instruments use different measuring procedures, some measuring in the normal direction, some measuring in other directions.

#### 4.4.4 Direction of tolerance

In this part of ISO 1328, the tolerance direction varies with the given elemental parameter. Original measurement values shall be compensated for if the actual measurement direction and the tolerance direction specified for the given parameter are different. See [4.4.8.2](#), [4.4.8.4](#) and [4.4.8.6](#) for sign conventions and the reporting of values.

The specified tolerance direction of measurement for all pitch deviations is in the transverse plane along the arc of the measurement diameter,  $d_M$ , circle.

The specified direction of tolerance for profile and helix deviations is in a transverse plane, on a line tangent to the base circle.

#### 4.4.5 Measurement diameter

This part of ISO 1328 specifies the measurement diameter,  $d_M$ , as defined in [3.2.2](#) as the location for the measurement of helix and pitch parameters (also see [4.4.3](#) and [4.4.4](#)). The measurement diameter shall be recorded on the inspection record. Since the tolerance values are calculated based on the reference diameter, they remain unchanged when the measurement diameter is modified.

When the measurement diameter is not specified, it is given by:

for external gears:

$$d_M = d_a - 2m_n \quad (1)$$

for internal gears:

$$d_M = d_a + 2m_n \quad (2)$$

where

$d_M$  is the measurement diameter, mm;

$d_a$  is the tip diameter, mm;

$m_n$  is the normal module, mm.

#### 4.4.6 Measurement data filtering

Any tooth surface will exhibit a wide spectrum of deviations from the specified tooth flank form. This includes, at one extreme, those of long period, such as a general concavity. At the other end of the spectrum are short period irregularities, such as surface roughness.

This part of ISO 1328 requires the modification of original measurement values for involute profile and helix evaluation so as to include only long period irregularities before analysis and comparison to tolerances. This modification is called low-pass filtering. It minimizes or excludes irregularities with wavelengths shorter than the specified filter cutoff wavelength. The filter cutoff wavelength specified by this part of ISO 1328 is the gear form filter cutoff,  $\lambda_\alpha$  or  $\lambda_\beta$ , as defined in 3.2.3 and 3.2.4. The profile form filter cutoff,  $\lambda_\alpha$ , shall be stated in terms of roll path length. The helix form filter cutoff,  $\lambda_\beta$ , shall be stated in terms of facewidth. The recommended form filter cutoff may be calculated using Formulae (3) and (4). Form filter cutoff wavelengths longer than these shall not be used.

$$\lambda_\alpha = \frac{L_\alpha}{30} \quad (3)$$

but not less than 0,25 mm

$$\lambda_\beta = \frac{b}{30} \quad (4)$$

but not less than  $\lambda_\alpha$

where

$\lambda_\alpha$  is the profile form filter cutoff, mm;

$\lambda_\beta$  is the helix form filter cutoff, mm.

The actual filter type and form filter cutoffs,  $\lambda_\alpha$  and  $\lambda_\beta$ , along with the probe diameter, shall be indicated on the inspection record. A Gaussian 50 % type filter is required and defined in accordance with ISO/TS 16610-1 and ISO 16610-21.

**WARNING — There are some cases where the filtering based on the form filter cutoff wavelength values recommended in Formulae (3) and (4) may suppress form deviations which are relevant to the function of the gear. Form deviations that exist with a wavelength between the recommended form filter cutoff and the filter cutoff used for surface roughness are sometimes referred to as waviness. When specified, form filter cutoff wavelengths that are shorter than those specified in Formulae (3) and (4) should be selected to evaluate such form deviations.**

See [Annex C](#) for additional information.

#### 4.4.7 Measurement data density

Measurement data density is closely related to measurement data filtering in that the data sampling rate limits the wavelength of surface irregularities which can be observed. The number of data points included in the evaluation length shall be shown on the inspection record. Involute profile measurement data sets shall include a minimum of 150 points approximately equally spaced along the length of roll. Helix measurement data sets shall include a minimum of  $5 \cdot b/\lambda_\beta$  points. If waviness is to be checked, then the data set shall include a minimum of 300 points or 5 points per millimetre, whichever is the greater.

#### 4.4.8 Required measuring and evaluation practices

##### 4.4.8.1 Profile measurement

The measurement probe shall travel the full profile length. The probe shall start below the profile control diameter and continue past where the tip break actually starts.

##### 4.4.8.2 Profile analysis

Within the profile evaluation range, the straight-line gradient of the profile measurement is found by applying the least squares method to the deviation of the measured profile trace from the specified design profile. The evaluation always starts at the profile control diameter  $d_{Cf}$ . Deviations caused by plus material beyond the profile evaluation range near the tip of the tooth shall be included in the calculation of the profile form deviation,  $f_{f\alpha}$ , and total profile deviation,  $F_\alpha$ . Minus material beyond the profile evaluation range near the tip of the tooth may be ignored (see [Figure 14](#)).



#### Key

|       |                                |       |                                  |
|-------|--------------------------------|-------|----------------------------------|
| ————— | measured profile               | ○     | Points on line of action         |
| ..... | facsimile of design profile    | $C_f$ | profile control                  |
| ----- | mean profile line              | $N_f$ | start of active profile          |
| ..... | facsimile of mean profile line | $F_a$ | tip form, where tip break starts |

**Figure 14 — Profile excess**

The mean profile line is developed by adding the ordinates of the straight-line gradient of the profile deviation to the ordinates of the design profile. The mean profile line is used to determine  $f_{f\alpha}$  [see [Figures 4 b](#)), 5 b), 6 b), 7 b), 8 b) and 14 b)] and  $f_{H\alpha}$  [see [Figures 4 c](#)), 5 c), 6 c), 7 c) and 8 c)].

For both internal and external gears, the profile slope deviation is deemed to be positive and the corresponding pressure angle deviation is deemed to be negative when the mean profile line shows an increase in material toward the tooth tip, relative to the design profile.

The profile is evaluated over the profile evaluation range, but for determination of the profile slope deviation the result is extrapolated to the tip diameter.

#### 4.4.8.3 Helix measurement

The measurement probe shall travel the full facewidth, from end face to end face, or, if present, from the start of end chamfers, rounds, or other modification intended to exclude that portion of the tooth from engagement.

#### 4.4.8.4 Helix analysis

Within the helix evaluation range, the straight-line gradient of the helix measurement is found by applying the least squares method to the deviation of the measured helix trace from the specified design helix. Deviations caused by plus material outside the helix evaluation range shall be included in the calculation of helix form deviation,  $f_{f\beta}$ , and total helix deviation,  $F_{\beta}$ . Minus material outside the helix evaluation range may be ignored (see [Figure 15](#)).

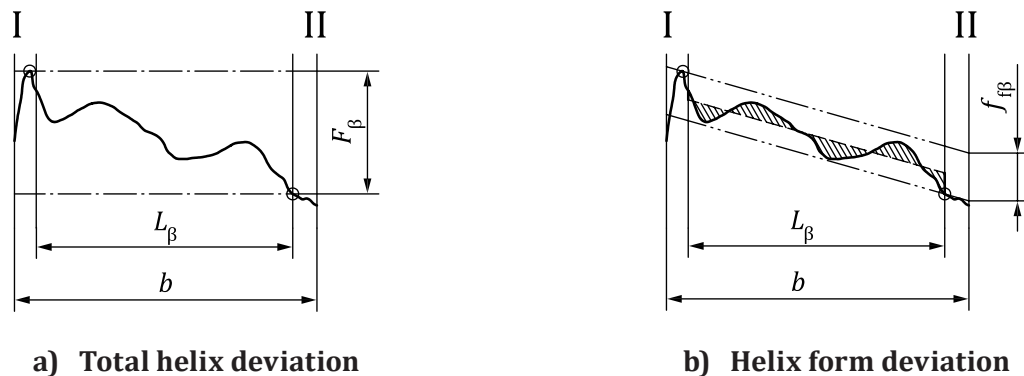

Figure 15 — Helix excess

The mean helix line is developed by adding the ordinates of the straight-line gradient of the helix deviation to the ordinates of the design helix. The mean helix line is used to determine  $f_{f\beta}$  [see [Figures 9 b](#)), 10 b), 11 b), 12 b), 13 b) and 15 b)] and  $f_{H\beta}$  [see [Figures 9 c](#)), 10 c), 11 c), 12 c) and 13 c)].

Helix slope deviations are deemed to be positive when the absolute values of the helix angles are larger, and negative when helix angles are smaller, than the designed helix angle. The helix slope deviations of spur gears are deemed + (positive) if right hand and - (negative) if left hand.

#### 4.4.8.5 Measurement location

Helix measurements shall be at the measurement diameter. Pitch measurements shall be at the measurement diameter unless the pitch measurements are used to evaluate tooth thickness. In this case the pitch measurement diameter should be the appropriate contacting diameter for the selected evaluation method (dimension over/under pins or ball measurement, chordal or circular tooth thickness). The reference diameter,  $d$ , shall be used for calculating the tolerance values in accordance with [Clause 5](#), irrespective of the measurement diameter.

#### 4.4.8.6 Reporting of pitch deviation values

##### 4.4.8.6.1 Individual single pitch deviation

Distinction is made as to the algebraic sign of this reading. A condition wherein the actual tooth flank position is nearer to the previous tooth flank than the theoretical position is considered a minus (-) deviation. A condition wherein the actual tooth flank position is further from the previous tooth flank than the theoretical position is considered a plus (+) deviation.

#### 4.4.8.6.2 Single pitch deviation values

This value is reported without a sign. It is reported separately for both the left and right flanks on inspection records.

#### 4.4.8.6.3 Individual cumulative pitch deviation

Distinction is made as to the direction and algebraic sign of this reading. In the specified measuring path direction [clockwise or counterclockwise (anticlockwise)], a condition wherein the actual tooth flank position is nearer to the datum tooth flank than the theoretical position is considered a minus (-) deviation, otherwise there is a plus (+) deviation.

#### 4.4.8.6.4 Total cumulative pitch deviation

Distinction is not made as to the direction or algebraic sign of this reading. Such a distinction would require a purely arbitrary specification of a direction [clockwise or counterclockwise (anticlockwise)] between the two teeth comprising the total cumulative pitch deviation. It is reported separately for both the left and right flanks on inspection records.

### 4.5 Specification of gear flank tolerance requirements

The information to define the gear flank tolerance requirements on the gear drawing or gear specification should include, but should not be limited to:

- a reference to this part of ISO 1328, i.e. ISO 1328-1:2013;
- the flank tolerance class of each tolerance parameter, which may be different for each parameter, and the limits, in micrometres, calculated in accordance with this part of ISO 1328;
- datum axis used for measurement (preferably the functional datum axis; see ISO/TR 10064-3);
- functional datum axis (used for evaluation);
- measurement diameter if different from the recommendation in [4.4.5](#);
- the minimum number of teeth to be inspected, if different from the minimum recommendation in [Table 5](#);
- the design shape for profile or helix modifications, if they are required;
- the range of evaluation for profile and helix measurement;
- the profile control diameter (defined as a diameter, length of roll or angle of roll);
- additional measurement requirements, for example tooth thickness (defined as circular thickness at reference diameter, span measurement or dimension over balls), tip and root diameter, root fillet profile, surface roughness of tooth flank.

It is usual to define this information as a table of data.

The designer may select the profile control diameter to be anywhere between the root form diameter and the start of active profile diameter. The root form diameter depends on either the undercut diameter, the point of tangency to the root fillet, or the base circle diameter (whichever is closest to the tip diameter). If a profile control diameter is not specified, the start of active profile diameter,  $d_{NF}$ , is used in place of the profile control diameter. When a gear will mesh with more than one mating gear, the start of active profile diameter should be considered for each of these gears when selecting the profile control diameter.



## 4.6 Acceptance and evaluation criteria

### 4.6.1 Designation of flank tolerance class

Designation/specification of a flank tolerance class in accordance with this part of ISO 1328 shall be as follows:

ISO 1328-1:2013, class A

where A designates the design flank tolerance class.

NOTE If the year of publication is not listed, the latest version of ISO 1328-1 applies.

### 4.6.2 Modified flank tolerance class

For a given gear, it is permissible to use different flank tolerance classes for each tolerance parameter.

### 4.6.3 Tolerances

The tolerances for each item that govern the flank tolerance class of gears are calculated by the formulae given in [Clause 5](#).

### 4.6.4 Acceptance criteria

The tolerances, methods, and definitions contained in this part of ISO 1328 prevail unless contractual agreements between the manufacturer and purchaser contain specific exceptions. See ISO 18653, ISO/TR 10064-5 and ISO 14253-1 for discussion on measurement uncertainty and how to apply to specified tolerances.

### 4.6.5 Evaluation of flank tolerance class

The overall flank tolerance class of a gear is determined by the largest flank tolerance class number measured for any tolerance parameter specified for the gear by this part of ISO 1328.

### 4.6.6 Additional characteristics

In certain applications there can be additional characteristics that might require tolerances in order to ensure satisfactory performance. For example, if dimensions for tooth thickness or surface finish tolerances are desirable in order to ensure satisfactory performance in special applications, such dimensions and tolerances should appear on drawings or purchase specifications. Methods of measuring some of these characteristics are discussed in ISO/TR 10064-1, and in [Annexes D](#) to [G](#).

## 4.7 Presentation of data

Throughout this part of ISO 1328, all the figures show how the design or measured profile deviates from a theoretical pure involute with the design pressure angle or how the design or measured helix deviates from a theoretical pure helix with the design helix angle. The figures show the profile and helix as generally horizontal lines, so as not to require indication of left or right flank or internal or external gear. Most measuring machines display the profile and helix as generally vertical lines; the orientation is not important.

## 5 Tolerance values

### 5.1 General

Tolerance values are calculated, in micrometres, by Formulae (5) to (12) given in [5.3](#).

## 5.2 Use of formulae

### 5.2.1 Range of application

The ranges of application are specified in the Scope ([Clause 1](#)), and Formulae (5) to (12) (in [5.3](#)) shall not be extrapolated beyond these limits. Tolerances for gears beyond these ranges shall be agreed upon by the manufacturer and purchaser.

### 5.2.2 Step factor

The step factor between two consecutive classes is  $\sqrt{2}$ . Values of the next higher (or lower) class are determined by multiplying (or dividing) by  $\sqrt{2}$ . The required value for any flank tolerance class may be determined by multiplying the unrounded calculated value for class 5 by  $\sqrt{2}^{(A-5)}$  where  $A$  is the number of the required flank tolerance class.

### 5.2.3 Rounding rules

Values calculated from Formulae (5) to (12) (in [5.3](#)) shall be rounded as follows:

- if greater than 10  $\mu\text{m}$ , round to the nearest integer micrometre;
- if 5,0  $\mu\text{m}$  or greater but less than or equal to 10  $\mu\text{m}$ , round to the nearest 0,5  $\mu\text{m}$ ;
- if less than 5,0  $\mu\text{m}$ , round to the nearest 0,1  $\mu\text{m}$ .

If the measuring instrument reads in (Imperial) inches, values calculated from Formulae (5) to (12) in [5.3](#) shall be converted to ten thousandths of an inch and then rounded according to the rules for micrometres (i.e. substitute “ten thousandths of an inch” for “micrometre” in the rules above). Parameters in Formulae (5) to (12) are intended to be entered in millimetres.

## 5.3 Tolerance formulae

### 5.3.1 Single pitch tolerance, $f_{pT}$

Single pitch tolerance,  $f_{pT}$ , shall be calculated using Formula (5):

$$f_{pT} = (0,001d + 0,4m_n + 5) (\sqrt{2})^{(A-5)} \quad (5)$$

### 5.3.2 Cumulative pitch (index) tolerance, total, $F_{pT}$

Total cumulative pitch (index) tolerance,  $F_{pT}$ , shall be calculated using Formula (6):

$$F_{pT} = (0,002d + 0,55\sqrt{d} + 0,7m_n + 12) (\sqrt{2})^{(A-5)} \quad (6)$$

### 5.3.3 Profile tolerances

#### 5.3.3.1 Profile slope tolerance, $f_{H\alpha T}$

Profile slope tolerance,  $f_{H\alpha T}$ , shall be calculated using Formula (7). This tolerance shall be applied as a plus/minus ( $\pm$ ) value.

$$f_{H\alpha T} = (0,4m_n + 0,001d + 4) (\sqrt{2})^{(A-5)} \quad (7)$$

### 5.3.3.2 Profile form tolerance, $f_{f\alpha T}$

Profile form tolerance,  $f_{f\alpha T}$ , shall be calculated using Formula (8):

$$f_{f\alpha T} = (0,55m_n + 5)(\sqrt{2})^{(A-5)} \quad (8)$$

### 5.3.3.3 Profile tolerance, total, $F_{\alpha T}$

Total profile tolerance,  $F_{\alpha T}$ , shall be calculated as given by Formula (9) using unrounded tolerance values for profile slope and profile form:

$$F_{\alpha T} = \sqrt{f_{H\alpha T}^2 + f_{f\alpha T}^2} \quad (9)$$

## 5.3.4 Helix tolerances

### 5.3.4.1 Helix slope tolerance, $f_{H\beta T}$

Helix slope tolerance,  $f_{H\beta T}$ , shall be calculated using Formula (10). This tolerance shall be applied as a plus/minus ( $\pm$ ) value.

$$f_{H\beta T} = (0,05\sqrt{d} + 0,35\sqrt{b} + 4)(\sqrt{2})^{(A-5)} \quad (10)$$

### 5.3.4.2 Helix form tolerance, $f_{f\beta T}$

Helix form tolerance,  $f_{f\beta T}$ , shall be calculated using Formula (11):

$$f_{f\beta T} = (0,07\sqrt{d} + 0,45\sqrt{b} + 4)(\sqrt{2})^{(A-5)} \quad (11)$$

### 5.3.4.3 Helix tolerance, total, $F_{\beta T}$

Total helix tolerance,  $F_{\beta T}$ , shall be calculated as given by Formula (12) using unrounded tolerance values for helix slope and helix form:

$$F_{\beta T} = \sqrt{f_{H\beta T}^2 + f_{f\beta T}^2} \quad (12)$$

## Annex A (normative)

### Zone-based tolerance evaluation

#### A.1 General

This annex presents a strategy using a segmented evaluation or zone evaluation for two or more zones. An example for the gear profile can be a tip zone, middle zone and root zone. Adjacent zones are calculated separately, and can have different tolerance classes.

#### A.2 Zone-based profile tolerance evaluation

For the determination of the slope and form deviation a regression calculation is necessary. In the case of tip and root modifications, each zone may be considered separately (see [Figure A.1](#)). For the calculation of the regression lines, only the zones  $L_{\alpha a}$ ,  $L_{\alpha m}$  and  $L_{\alpha f}$  are used. The areas between the zones are only considered for the plus material condition for form and total deviation. The length of these areas shall be defined and cannot be zero (except when there is a tangential transition). The regression is calculated on the deviations from the design profile according to the sum of the least squares (Gauss). In most cases, a linear regression is used.

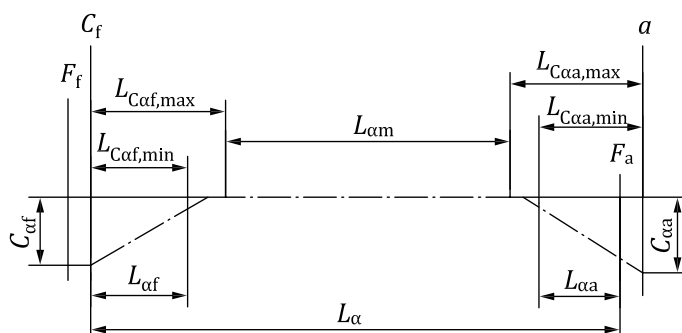

#### Key

|                          |                               |                          |
|--------------------------|-------------------------------|--------------------------|
| $C_{\alpha a}$           | amount of tip relief          | Points on line of action |
| $C_{\alpha f}$           | amount of root relief         | $a$ tip                  |
| $L_{C_{\alpha a}, \max}$ | maximum length of tip relief  | $C_f$ profile control    |
| $L_{C_{\alpha a}, \min}$ | minimum length of tip relief  | $F_a$ tip form           |
| $L_{C_{\alpha f}, \max}$ | maximum length of root relief | $F_f$ root form          |
| $L_{C_{\alpha f}, \min}$ | minimum length of root relief |                          |
| $L_{\alpha a}$           | tip relief zone               |                          |
| $L_{\alpha m}$           | middle profile zone           |                          |
| $L_{\alpha f}$           | root relief zone              |                          |

Figure A.1 — Regression zones for profile with tip and root modification

#### A.2.1 Profile slope deviation, $f_{H\alpha}$

For the profile slope deviation,  $f_{H\alpha}$ , the regression line of the middle profile zone shall be extrapolated over the area from the profile control point to the tip [see [Figure A.2 c](#)].

### A.2.2 Profile form deviation, $f_{f\alpha}$

The profile form deviation,  $f_{f\alpha}$ , is the distance between two facsimiles of the regression lines which enclose the measured profile within the zone. For each zone, the form deviation is determined independently. For the area above the tip break, a plus material condition is included in the adjacent zone [see [Figure A.2 b](#)].

NOTE The facsimiles of the regression line are kept parallel to the regression line.

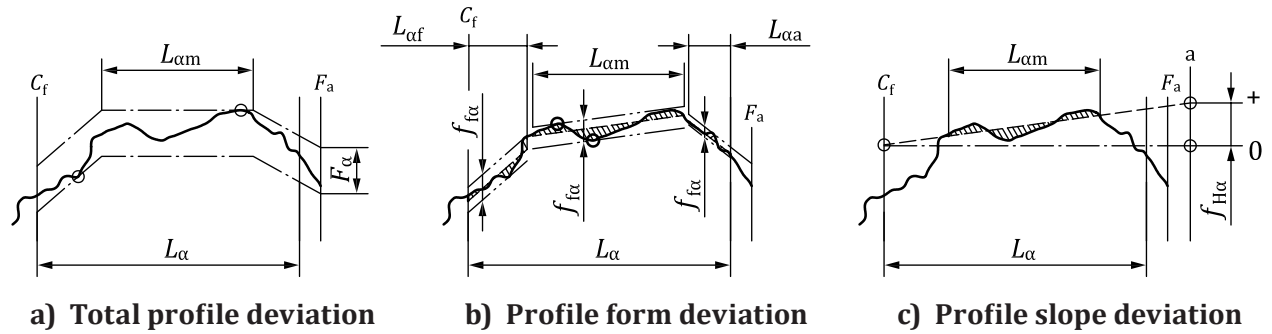

#### Key

|           |                                |       |                          |
|-----------|--------------------------------|-------|--------------------------|
| —————     | measured profile               | ○     | Points on line of action |
| - - - - - | facsimile of design profile    | $C_f$ | profile control          |
| —————     | mean profile line              | $F_a$ | tip form                 |
| - - - - - | facsimile of mean profile line | a     | tip                      |

Figure A.2 — Zone-based evaluation for profile with tip and root modifications

### A.2.3 Total profile deviation, $F_\alpha$

The total profile deviation,  $F_\alpha$ , is the distance between two facsimiles of the design profile which envelop the actual profile as shown in [Figure A.2 a](#)). Outside the evaluation range at the tip, excess material shall be taken into account.

NOTE 1 The facsimiles of the design profile are kept parallel to the design profile.

NOTE 2 It is common practice to restrict evaluation to the middle zone or to omit  $F_\alpha$  completely.

## A.3 Zone-based helix tolerance evaluation

For the determination of the slope and form deviation, a regression calculation is necessary. In the case of end relief, each zone is considered separately. The areas close to the faces are denoted with I and II (see [Figure A.3](#)).

For the calculation of the regression lines only the zones  $L_{\beta I}$ ,  $L_{\beta m}$ , and  $L_{\beta II}$  are used. The areas between the zones are only considered for the plus material condition for form and total deviation. The length of these areas shall be defined and cannot be zero (except when there is a tangential transition). The regression is calculated on the deviations from the design helix according to the sum of the least squares (Gauss). In most cases, a linear regression is used.

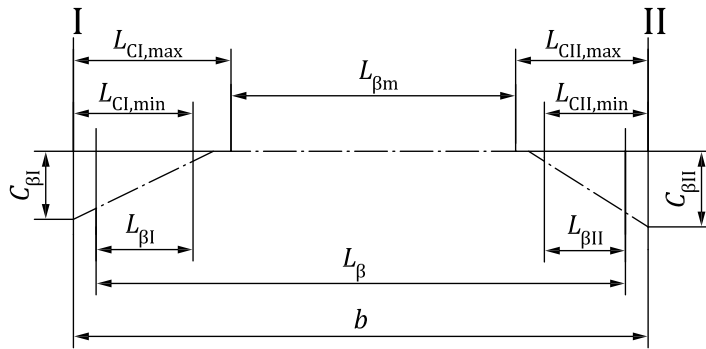

**Key**

|                |                              |                |                              |
|----------------|------------------------------|----------------|------------------------------|
| I              | datum face                   | $L_{CII,max}$  | maximum length of end relief |
| II             | non-datum face               | $L_{CII,min}$  | minimum length of end relief |
| $C_{\beta I}$  | amount of end relief         | $L_{\beta I}$  | end relief zone              |
| $C_{\beta II}$ | amount of end relief         | $L_{\beta m}$  | middle helix zone            |
| $L_{CI,max}$   | maximum length of end relief | $L_{\beta II}$ | end relief zone              |
| $L_{CI,min}$   | minimum length of end relief |                |                              |

**Figure A.3 — Regression zones for a helix with relief at both ends**

**A.3.1 Helix slope deviation,  $f_{H\beta}$**

For the helix slope deviation,  $f_{H\beta}$ , the regression line of the middle zone shall be extrapolated to the whole facewidth,  $b$  [see [Figure A.4 c](#)].

**A.3.2 Helix form deviation,  $f_{f\beta}$**

The helix form deviation,  $f_{f\beta}$ , is the distance between two facsimiles of the regression line which enclose the measured helix within the zone. For each zone the form deviation is determined independently [see [Figure A.4 b](#)]. For the area between the zones and at the ends, any plus material shall be included in the analysis.

NOTE The facsimiles of the regression line are kept parallel to the regression line.

### A.3.3 Total helix deviation, $F_\beta$

The total helix deviation,  $F_\beta$ , is the distance between two facsimiles of the design helix which envelop the actual helix [see Figure A.4 a)]. Outside the evaluation range,  $L_\beta$ , at the ends of the flank, excess material shall be taken into account.

NOTE 1 The facsimiles of the design helix are kept parallel to the design helix.

NOTE 2 It is common practice to restrict evaluation to the middle zone or to omit  $F_\beta$  completely.

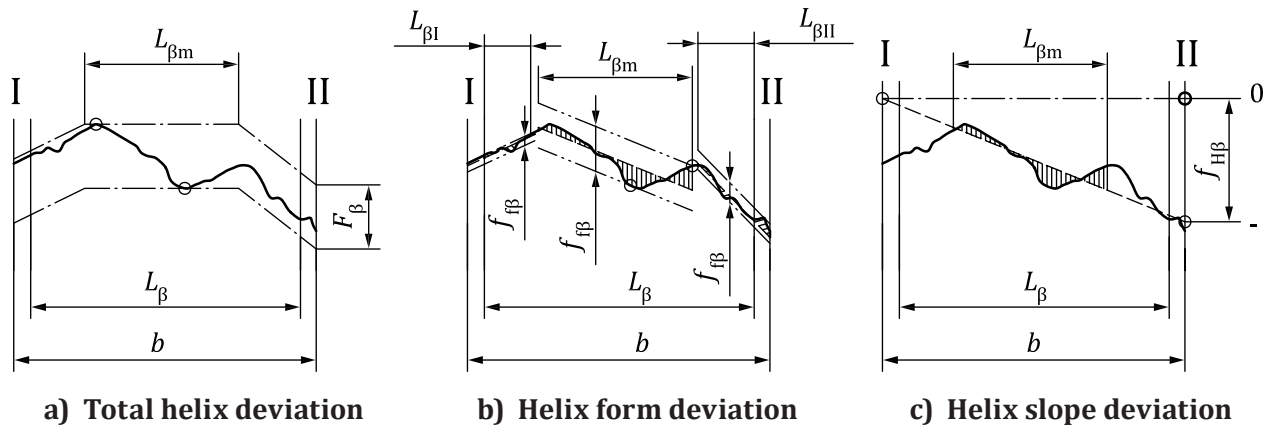

#### Key

|       |                              |                |                                  |
|-------|------------------------------|----------------|----------------------------------|
| ————— | measured helix               | $L_{\beta I}$  | end relief zone (datum face)     |
| ----- | facsimile of design helix    | $L_{\beta II}$ | end relief zone (non-datum face) |
| ----- | mean helix line              | $L_{\beta m}$  | middle helix zone                |
| ----- | facsimile of mean helix line |                |                                  |

Figure A.4 — Zone-based evaluation for a helix with end modifications

## Annex B (normative)

### Evaluation of profile and helix deviations using the second order analysis method

#### B.1 Purpose

This annex applies to gears with either a crowned profile (sometimes called barrelling) or a crowned helix, or to gears with both. A second order best fit is applied to the deviations from the unmodified profile or the unmodified helix. The standard flank tolerance classes from [Clause 5](#) may be used with this method of analysis.

NOTE [Clauses 3](#) and [4](#) use linear analysis of the deviations from the design profile and the design helix rather than a second order fit. The result of the linear analysis is referred to as a mean profile (or helix) **line** even though it has the same shape as the design profile (or helix), which can be a curve. The result of the second order analysis as presented in this annex is always referred to as a **curve**.

#### B.2 Second order profile analysis

Profile crowning is a commonly used and effective profile modification for some applications. Crowning modifications are generally defined by a single parabolic curve (see [Figure B.1](#)). The calculation of the parabola is executed within  $L_\alpha$ , but for the evaluation of  $f_{H\alpha}$  and  $C_\alpha$ , the parabola is extrapolated to the tip diameter for unsegmented designs or to the end of the segment when analysed by zones.

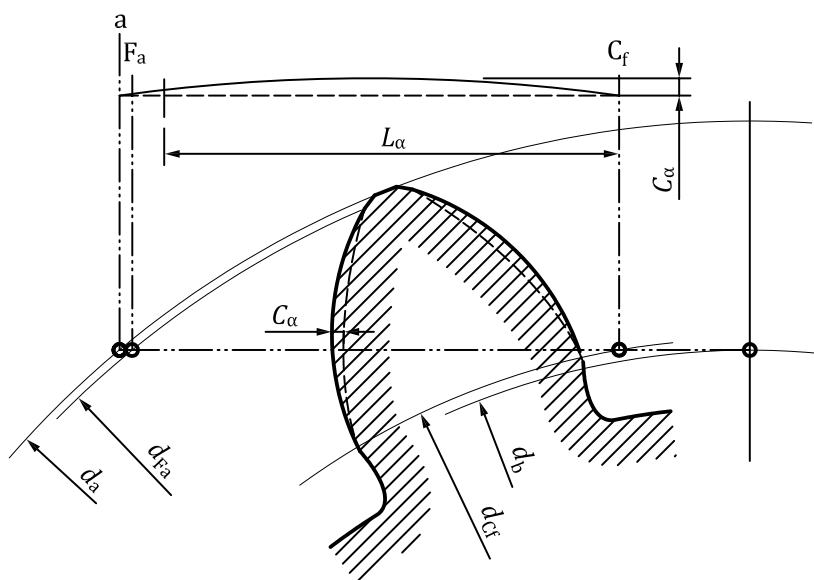

**Key**  
 - - - - - involute  
 ———— crowned profile

**Figure B.1 — Profile crowning**



### B.2.1 Mean second order profile curve

The mean second order profile curve is a curve created by mathematically fitting a second order curve to the measured profile trace, within the profile evaluation length,  $L_\alpha$ , by the least squares method.

NOTE This curve is the basis of the determination of  $f_{f\alpha}$ ,  $f_{H\alpha}$  and  $C_\alpha$ .

### B.2.2 Profile form deviation, $f_{f\alpha}$

The profile form deviation,  $f_{f\alpha}$ , is the distance between two facsimiles of the mean second order profile curve, which are each placed with constant separation from the mean second order profile curve, so as to enclose the measured profile over the profile evaluation length,  $L_\alpha$  [see 3.3.10 and [Figure B.2 a](#)]. See [4.4.8.2](#) for plus material conditions.

### B.2.3 Profile slope deviation, $f_{H\alpha}$

The profile slope deviation,  $f_{H\alpha}$ , is the displacement of a line struck through the points where the extrapolated mean second order profile curve intersects the profile control diameter and the tip diameter [see [Figure B.2 b](#)].

The algebraic sign of profile slope deviation,  $f_{H\alpha}$ , using the second order method is determined in the same manner as given in [4.4.8.2](#).

If there is a design profile slope deviation,  $C_{H\alpha}$ , the initially calculated  $f_{H\alpha C}$  is used to determine the profile slope deviation according to Formula (B.1):

$$f_{H\alpha} = f_{H\alpha C} - C_{H\alpha} \quad (\text{B.1})$$

### B.2.4 Profile crowning, $C_\alpha$

The profile crowning,  $C_\alpha$ , is the distance, in the direction of recorded deviations, between the chord to the extrapolated mean second order profile curve where it intersects the profile control diameter and the tip diameter and a parallel line which is tangent to the mean second order profile curve [see [Figure B.2 c](#)].

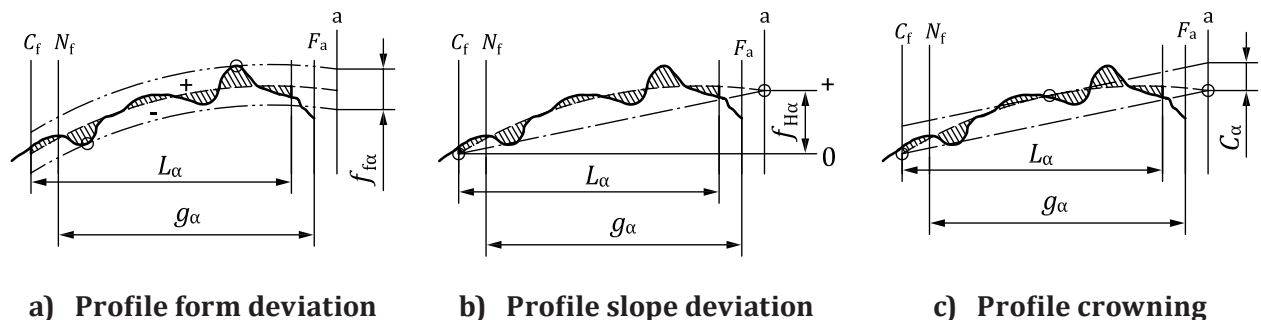

#### Key

|       |  |                               |
|-------|--|-------------------------------|
| ————— | measured profile                             | Points on line of action      |
| ----- | mean second order profile curve              | $C_f$ profile control         |
| ..... | facsimile of mean second order profile curve | $N_f$ start of active profile |
| ..... | chord of mean second order profile curve     | $F_a$ tip form                |
|       |  | a tip                         |

Figure B.2 — Second order profile deviations

### B.3 Second order helix analysis

Similar to profile crowning, helix crowning is a commonly used helix modification. This modification is generally defined by a single parabolic curve that increases the curvature of the helix and crests at the middle of the helix evaluation range,  $L_\beta$ . The calculation of the parabola is executed within  $L_\beta$ , but for the evaluation of  $f_{H\beta}$  and  $C_\beta$ , the parabola is extrapolated to the full facewidth,  $b$ , for unsegmented designs, or to the end of the segment when analysed by zones.

#### B.3.1 Mean second order helix curve

The mean second order helix curve is a curve that is created by mathematically fitting a second order curve to the measured helix trace, within the helix evaluation range,  $L_\beta$ , by the least squares method.

NOTE This curve is the basis of the determination of  $f_{f\beta}$ ,  $f_{H\beta}$  and  $C_\beta$ .

#### B.3.2 Helix form deviation, $f_{f\beta}$

The helix form deviation,  $f_{f\beta}$ , is the distance between two facsimiles of the mean second order helix curve, which are each placed with constant separation from the mean second order helix curve, so as to enclose the measured helix trace over the helix evaluation range,  $L_\beta$  [see [Figure B.3 a](#)]. See [4.4.8.4](#) for plus material conditions.

#### B.3.3 Helix slope deviation, $f_{H\beta}$

The helix slope deviation,  $f_{H\beta}$ , is the displacement of a line struck through the points where the mean second order helix curve intersects the end points of the facewidth,  $b$  [see [Figure B.3 b](#)].

The algebraic signs of helix slope deviation,  $f_{H\beta}$ , using the second order method are determined in the same manner as in [4.4.8.4](#).

If there is a design helix slope deviation,  $C_{H\beta}$ , then the initially calculated  $f_{H\beta C}$  is used to determine the helix slope deviation according to Formula (B.2):

$$f_{H\beta} = f_{H\beta C} - C_{H\beta} \tag{B.2}$$

#### B.3.4 Helix crowning, $C_\beta$

The helix crowning,  $C_\beta$ , is the distance, in the direction of recorded deviations, between the helix slope line and a parallel line which is tangent to the mean second order helix curve [see [Figure B.3 c](#)].

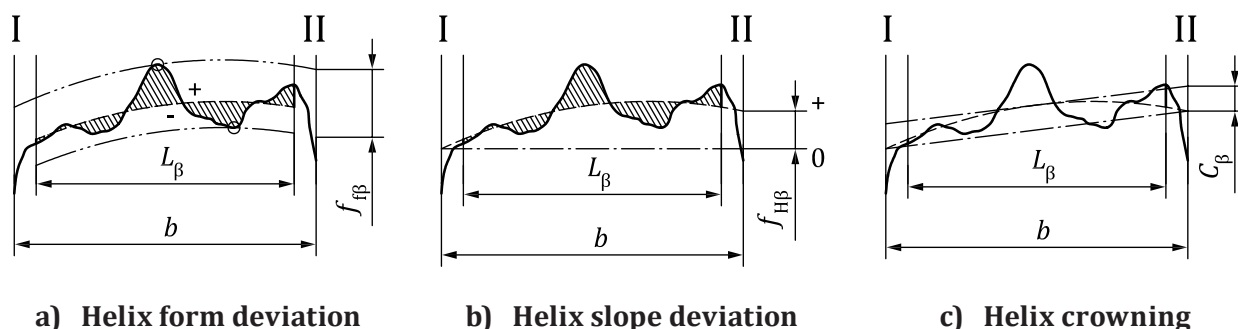

#### Key

- measured helix
- mean second order helix curve
- ..... facsimile of mean second order helix curve

Figure B.3 — Second order helix deviations

## **Annex C** (informative)

### **Profile and helix data filtering**

#### **C.1 Purpose**

Profile and helix measurement data are usually conditioned by low-pass filtering prior to analysis procedures. The selected filtering method and cutoff wavelength influences analysis results. This annex provides descriptions of filtering practices.

#### **C.2 Filtering**

Measurements include variations of many different wavelengths or frequencies. The exclusion of certain portions of the measurement data frequency spectrum is called filtering. A filter that excludes short wavelength (high frequency) data is called a low-pass filter. A filter that excludes long wavelength (low frequency) data is called a high-pass filter. A filter that excludes the shortest and longest wavelengths (highest and lowest frequencies), thereby leaving only medium wavelength (medium frequency) data, is called a bandpass filter. For gear metrology purposes, a low-pass filter is usually applied to remove the influences of high-frequency surface finish conditions from the observations of total, form and slope deviations of profile and helix. Several types of filtering are normally present in the gear measuring system.

#### **C.3 Mechanical filtering**

Mechanical filtering limits the profile and helix measurement data gathered to longer wavelength values and is thus a low-pass type filter. Mechanical filtering occurs as the geometry of the probe (i.e. tip radius) bridges and thereby suppresses the shorter wavelength variations. Another relevant source of mechanical low-pass filtering is the inertial mass of the moving parts of the probing system.

In applications that require inclusion of higher frequency data, smaller probe tip radii can be specified. Since gear profile and helix data are normally subjected to intentional low-pass filtering, this is rarely required. Evaluation of gear surface finish is best accomplished with specialized surface finish instruments, rather than profile or helix measurement instruments.

#### **C.4 Electrical filtering**

Electrical filtering that limits the measurement data gathered to longer wavelengths (lower frequency) values is a low-pass type filter. During electrical filtering, the measurement data signal passes from the probe head through an electrical filtering (RC) circuit and finally on to the data analysis and output devices.

Electrical filtering circuits for profile and helix data are designed to accomplish the elimination of high frequency measurement data at a specified wavelength called the cutoff. All data at frequencies significantly higher than the cutoff are eliminated. High-frequency measurement data that are near but not exactly at the cutoff frequency are filtered proportionally according to their proximity to the cutoff wavelength.

An unfortunate effect of RC electrical filtering is a phase shifting of data that can influence the analysis of measurement results.

Electrical filtering is most commonly encountered on older instruments; newer instruments employ mathematical filtering. Electrical filtering is an acceptable practice, provided its limitations are understood.

## C.5 Mathematical filtering

Mathematical filtering requires that measurement data first be converted from analogue to digital to permit processing by a digital computer. There are many mathematical filters available today. One common filter emulates the characteristics of electrical filters (with or without the phase shifting characteristic of RC circuits). Another common filter employs Gaussian mathematics.

The transmission characteristics of a phase correct Gaussian filter are such that 50 % of the amplitude of a sinusoidal waveform with a wavelength equal to the long-wavelength cutoff will be transmitted. Other frequencies are passed in an amount according to their proximity to the cutoff. When a phase correct Gaussian filter is used, irregularities are reduced and phase shift is eliminated.

Based upon sine wave amplitude transmission characteristics and compliance with ISO standards, use of the digital Gaussian 50 % filter is required (see [4.4.6](#)).

It is also advantageous to be able to view the measurement data with different (or no) mathematical filtering applied.

## C.6 Cutoff selection

Standard profile and helix data cutoff values for use in this part of ISO 1328 are specified in [4.4.6](#).

## Annex D (informative)

### Sector pitch deviation

#### D.1 Purpose

This annex provides the definition, measurement practices, recommended tolerances, and guidance for application of sector pitch deviation.

#### D.2 Sector pitch deviation, $F_{pk}$ , $F_{pz/8}$

The sector pitch deviation,  $F_{pk}$ , is the largest algebraic difference between the individual cumulative pitch deviation (index deviation) values for a specified flank within any sector of  $k$  pitches. In the specific case where  $k$  is one eighth of the number of teeth,  $z$ , it is named  $F_{pz/8}$ .

NOTE 1 Unless otherwise specified,  $k$  is limited to one eighth of the number of teeth. For segment gears, the number of teeth,  $z$ , is that for a full gear, and not the number of teeth in the segment gear.

NOTE 2 When a specific number of teeth is specified, that number appears in the symbol in place of  $k$ ; i.e. if sectors of four teeth are used, the symbol is  $F_{p4}$ .

NOTE 3 When  $F_{pz/8}$  is specified, then

$$k \approx \frac{z}{8} \quad (\text{D.1})$$

where

$k$  is the number of pitches in the sector; it is rounded to the nearest integer of pitches;

$z$  is the number of teeth in the gear.

The smallest useful value of  $k$  is 2. Parameter  $F_{pz/8}$  is only applicable to gears with 12 or more teeth.

Distinction is made as to the algebraic sign of this reading. Thus, a condition wherein the distance between the two teeth comprising the sector pitch deviation is shorter than the theoretical distance is considered a minus (-) deviation. A condition wherein the distance between the two teeth comprising the sector pitch deviation is longer than the theoretical distance is considered a plus (+) deviation.

The measurement direction for sector pitch deviation is along the arc of the measurement diameter circle,  $d_M$ , within the transverse plane.

#### D.3 Measurement practice

Gear tooth position data gathered by either a pitch comparator (two-probe) device or an indexing (single-probe) device may be used to determine sector pitch deviation. In either case, individual cumulative pitch deviation (index deviation) values shall be found first. Determination of the sector pitch deviation,  $F_{pk}$ , requires the algebraic difference of the most positive individual cumulative pitch deviation (index deviation) value and the most negative individual cumulative pitch deviation (index deviation) value within every group of  $k$  pitches ( $k + 1$  adjacent teeth), as defined in D.2. The sector pitch deviation,  $F_{pk}$ , is the largest of these values. There are as many groups of  $k$  pitches as there are teeth.

## D.4 Comparison to similar parameters

It is important to understand that parameter  $F_{pk}$  is not equivalent to certain other similar parameters, such as pitch span deviation  $F_{pSk}$ . Pitch span deviation is equal to the algebraic difference between the first and last values of the individual cumulative pitch deviation (index deviation) in a sector of  $k$  pitches.

In both cases, a window of  $k$  spaces is used. For  $F_{pk}$ ,  $z$  windows of length  $k$  are used and (maximum reading minus minimum reading) is determined for each window for all values inside the window.

For  $F_{pSk}$ , the number of windows is equal to the nearest integer of  $z/k$ . For each interval, only the first and last values are considered to determine the difference.

NOTE The tolerance for  $F_{pSk}$  is not specified in this part of ISO 1328.

An example of the differences between these analysis methods is provided by [Figure D.1](#). That Figure shows the individual cumulative pitch deviation (index deviation) data for a gear with 35 teeth, thus for  $F_{pz/8}$ , the value of  $k$  is equal to 4. In this example, the value of sector pitch deviation,  $F_{pz/8}$ , is 4,7 occurring between teeth 18 and 20, which are contained within a sector of 4 pitches. The value of pitch span deviation,  $F_{pS4}$ , is 4,1 occurring from teeth 18 and 22, which are 4 pitches apart. In this example,  $F_{pz/8}$  and  $F_{pS4}$  occur in the same sector; this is not always the case.

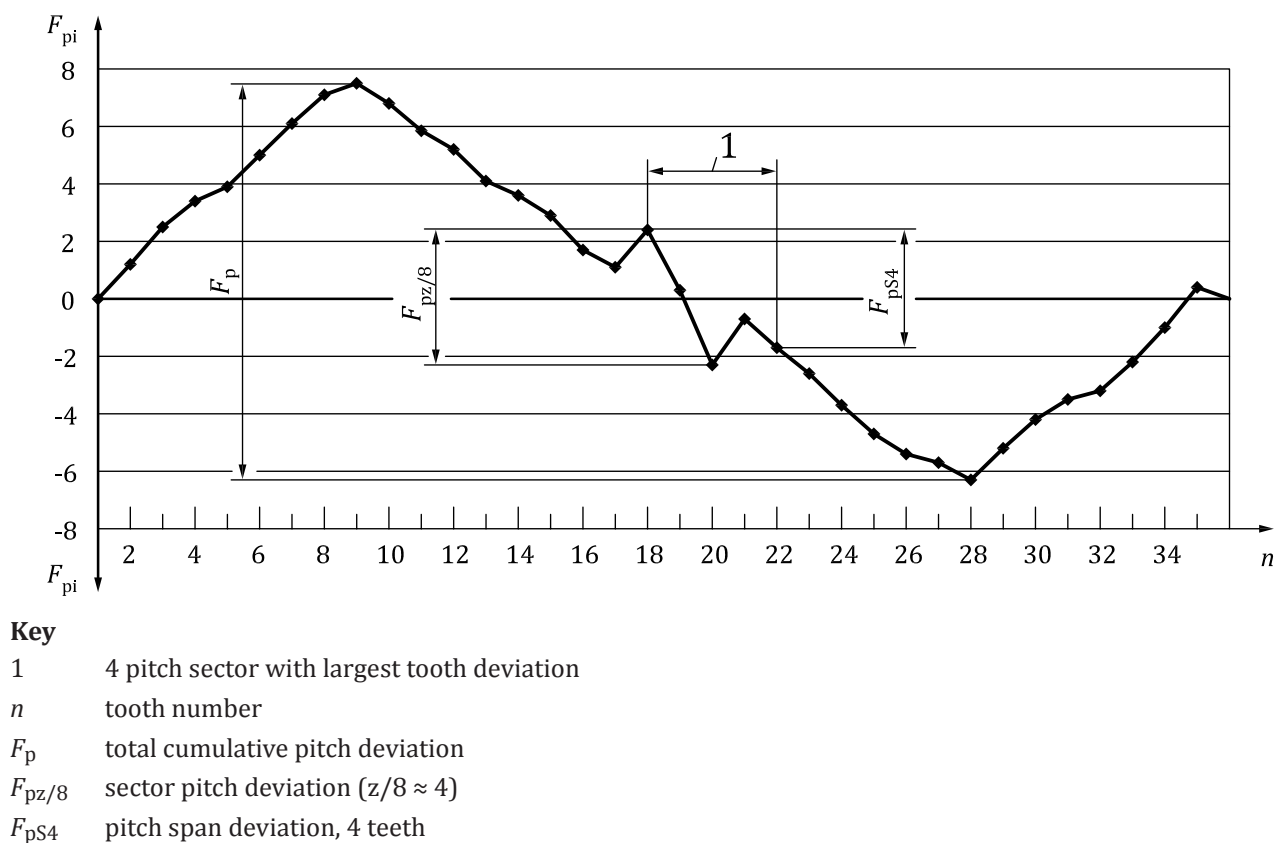

Figure D.1 — Sector pitch deviation and pitch span deviation

## D.5 Tolerance, sector pitch deviation, $F_{pkT}$

A recommended tolerance for sector pitch deviation,  $F_{pkT}$ , is calculated according to Formula (D.2):

$$F_{pkT} = f_{pT} + \frac{4k}{z} (0,001d + 0,55\sqrt{d} + 0,3m_n + 7) (\sqrt{2})^{A-5} \quad (D.2)$$

where

$F_{pkT}$  is the tolerance, sector pitch;

$f_{pT}$  is the tolerance, single pitch, for the tolerance class A.

A recommended range of application for sector pitch tolerance follows the same restrictions as those specified for total cumulative pitch tolerance,  $F_{pT}$ .

For the specific case of  $F_{pz/8}$ , Formula (D.2) may be simplified to:

$$F_{pz/8T} = \frac{f_{pT} + F_{pT}}{2} \quad (D.3)$$

## D.6 Guidance to application

Unless otherwise specified, the measurement of sector pitch deviation is not mandatory. Information pertaining to this parameter is therefore not included in (the main body of) this part of ISO 1328.

However, when agreed between the manufacturer and purchaser, the method may be used. If differences between individual cumulative pitch deviations (index deviations) over relatively small numbers of pitches are too large, substantial acceleration forces can be generated when the gear is in service, especially for high speed gears, where dynamic loads can be considerable.

## Annex E (normative)

### Allowable values of runout

#### E.1 Purpose

This annex provides the tolerance formula and range of application.

#### E.2 Individual radial measurement, $r_i$

The individual radial measurement,  $r_i$ , is the radial distance from the gear axis to the centre or other defined location of a probe (ball, cylinder or anvil), which is placed successively in each tooth space. During each check, the probe contacts both the right and left flanks at approximately midtooth-depth. The runout may also be determined by using the points from the pitch measurement (see E.5 and [Figure E.2](#)).

NOTE 1 There are as many values for  $r_i$  as there are tooth spaces.

NOTE 2 The results from a physical measurement usually give slightly different results from those calculated from the pitch measurement.

When a specific ball diameter for runout measurement is required, the contact diameter for this ball shall be used for pitch measurements, if these measurements will be used for calculation of runout. Otherwise, the measurement diameter,  $d_M$ , shall be used.

#### E.3 Runout, $F_r$

The value of the runout,  $F_r$ , of the gear is the difference between the maximum and the minimum individual radial measurement,  $r_i$ . [Figure E.1](#) shows an example of a runout diagram, in which the eccentricity is a portion of the runout (see ISO/TR 10064-2).



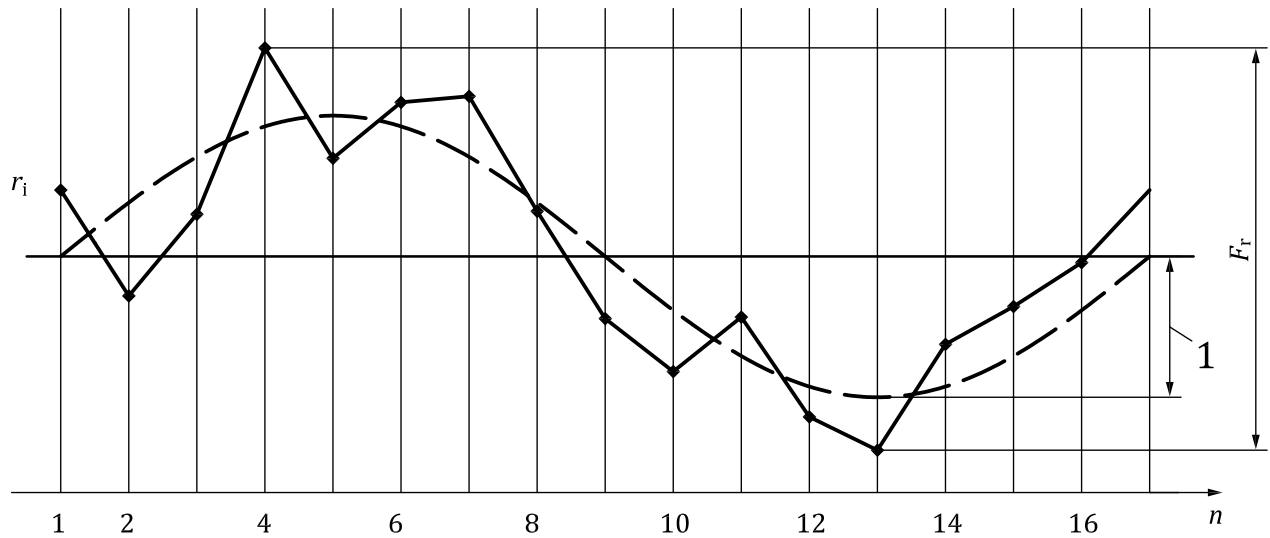

**Key**

- 1 eccentricity
- $n$  tooth space number

**Figure E.1 — Runout diagram of a gear with 16 teeth**

**E.4 Recommended formula for runout tolerance,  $F_{rT}$**

Runout tolerance,  $F_{rT}$ , shall be calculated using Formula (E.1):

$$F_{rT} = 0,9F_{pT} = (0,9) \left( 0,002d + 0,55\sqrt{d} + 0,7m_n + 12 \right) \left( \sqrt{2} \right)^{A-5} \quad (E.1)$$

where the range of application is restricted as follows:

tolerance classes 1 to 11

$$5 \leq z \leq 1\,000$$

$$5 \text{ mm} \leq d \leq 15\,000 \text{ mm}$$

$$0,5 \text{ mm} \leq m_n \leq 70 \text{ mm}$$

**E.5 Calculation of runout from pitch measurements**

From the probings at the measurement diameter, the positions of the left and right flanks are known. In a transverse plane, involutes are created in the tooth space at a distance from the measured points that is equal to the radius of the ball divided by the cosine of the base helix angle. The distance is measured in a direction along a tangent to the base circle. The intersection of the two involutes for each tooth space gives the approximate radial position of the centre of the test ball. These positions may also be used for the determination of dimension over balls. The results may deviate slightly from those actually made with a ball in two flank contact, due to differences in contact location and surface irregularities. See [Figure E.2](#), which shows a simplified example for a spur gear.

## E.6 Guidance to application

Unless otherwise specified, the measurement of runout is not mandatory. Information pertaining to this parameter is, therefore, not included in (the main body of) this part of ISO 1328. However, when agreed between the manufacturer and purchaser, the method may be used.

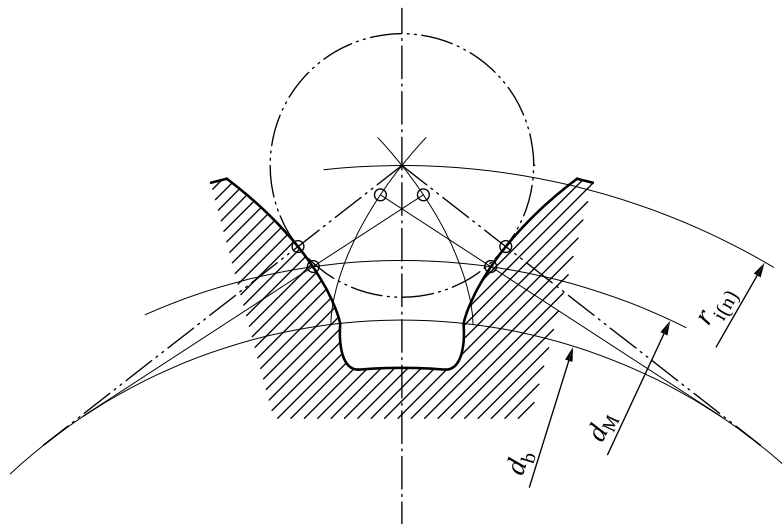

Figure E.2 — Runout from pitch measurement

## Annex F (informative)

### Single flank composite testing

#### F.1 Purpose

##### F.1.1 General

This annex is provided as a discussion of gear transmission error (deviation) and to give a default tolerance value for tooth mesh single flank composite deviation,  $f_{is(\text{design})}$ . Transmission error is the deviation of the angular position of the driven gear, for a given angular position of the driving gear, from the position that the driven gear would occupy if the gears were geometrically perfect.

Single flank inspection is a method used to measure transmission error. It is typically conducted on instruments that run gears together as a pair. At times, it is also conducted with a product gear running against a master gear, to measure the individual gear contribution to the transmission error. These tests are normally conducted at very light torque loads in order to avoid deflections of the typical production test machines that can influence the measured results. When it is necessary to test under heavy loads, such as in the actual application, this should be done in the actual gear box or a special very rigid test box, but this is beyond the scope of this annex.

With single flank testing, gears roll together at their specified centre distance and alignment with only one set of flanks in contact. The gear pair should have backlash. Because single flank testing of gears simulates operation in their application, deviations of a gear pair detected by this test are useful to control gear functional characteristics. Nicks and burrs may also be detected.

Single flank testing will show results for no-load total transmission error and tooth-to-tooth error. Tooth-to-tooth transmission error is the parameter of importance when looking for smoothness of motion or control of noise and vibration. When considering tolerances for no-load total transmission error, accumulated pitch error is the prime source. When analysing tooth-to-tooth error, conjugacy of mating teeth (matching of involute shape) is the prime source.

There are two groups of gear types to be considered when establishing tolerances for tooth-to-tooth no-load transmission error: unmodified tooth shapes and modified tooth shapes.

##### F.1.2 Unmodified tooth shapes

Unmodified tooth shapes are used for gears in many applications such as home appliances, power hand tools, automotive accessory drives and many others, which run at very low loads. For low loads, the more conjugate the teeth are, the smoother they run, and they will generate less noise and vibration. Therefore, any result less than the tolerance value is acceptable.

##### F.1.3 Modified tooth shapes

Modified tooth shapes (profile crowning, tip relief, profile slope, etc.) may show relatively high tooth-to-tooth transmission error. This is because they are tested at light loads, while the teeth have been designed to be conjugate only at a specified high load condition. They, therefore, are not conjugate at low inspection loads. If the tooth-to-tooth transmission error is much less than expected, that would not be good. Therefore, in the modified situation, there should be maximum and minimum tolerances.

There are two alternative methods to determine these maximum and minimum tolerances:

- a) based on experience in actual applications;

- b) through the use of tooth contact analysis software programs that determine tooth shape and predicted transmission error curves. These programs analyse the tooth shapes as they run under load and also account for housing and shaft deflections. They then predict the tooth-to-tooth transmission error at various load levels and one would expect to know what it should look like under light loads in a single flank tester.

#### F.1.4 Method A

The design and manufacture determination of single flank composite mean tooth mesh component value, and its variability, is developed using application experience or load capacity testing, or both, to determine the required values. These values are regardless of quality class.

#### F.1.5 Method B

The peak-to-peak amplitude of the short-term component (high-pass filtered) of the single flank composite deviation is used to determine the tooth mesh component. The highest peak-to-peak amplitude shall not be greater than  $f_{isTmax}$  and the lowest peak-to-peak amplitude shall not be smaller than  $f_{isTmin}$ . The peak-to-peak amplitude is the difference between the highest point and the lowest point of the motion curve within one pitch of the gear set being measured.

The maximum and minimum values of the single flank composite tolerance, tooth mesh component,  $f_{isT}$ , for a gear pair shall be calculated according to Formulae (F.1) and (F.2), or (F.1) and (F.3), in micrometres.

$$f_{isT,max} = f_{is(\text{design})} + (0,375 m_n + 5,0) (\sqrt{2})^{(A-5)} \quad (\text{F.1})$$

The value of  $f_{isTmin}$  is the larger one of:

$$f_{isT,min} = f_{is(\text{design})} - (0,375 m_n + 5,0) (\sqrt{2})^{(A-5)}, \text{ or} \quad (\text{F.2})$$

$$f_{isT,min} = 0 \quad (\text{F.3})$$

The range of application is restricted as follows:

flank tolerance classes 1 to 11

$$1,0 \text{ mm} \leq m_n \leq 50 \text{ mm}$$

$$5 \leq z \leq 400$$

$$5 \text{ mm} \leq d \leq 2\,500 \text{ mm}$$

If the measuring instrument reads in units of angle, the conversion to micrometres should be done at the reference diameter,  $d$ .

$$f_{isT} \text{ (micro radians)} = 2\,000 \times f_{isT} \text{ (micrometres)} / d \text{ (mm)} \quad (\text{F.4})$$

The design value for tooth mesh component single flank composite deviation,  $f_{is(\text{design})}$ , for Formulae (F.1) and (F.2), should be determined with an analysis for the application design and testing conditions. Consideration should be given in selecting the design value such that it includes influences, such as mounting variation, variability of flank form and application operating loads. See F.2 for additional information.

### F.1.6 Single flank composite tolerance, total, $F_{isT}$

Single flank composite tolerance, total,  $F_{isT}$ , shall be calculated according to Formula (F.5):

$$F_{isT} = F_{pT} + f_{isT,max} \quad (F.5)$$

where the range of application is restricted as follows, if  $F_{isT}$  is specified:

flank tolerance grades 1 to 11

$$1,0 \text{ mm} \leq m_n \leq 50 \text{ mm}$$

$$5 \leq z \leq 400$$

$$5 \text{ mm} \leq d \leq 2\,500 \text{ mm}$$

## F.2 Structure of the tester and obtained data

[Figure F.1](#) shows the schematic view of the single flank tester. The rotary angles  $\theta_1$  and  $\theta_2$  are detected by the rotary angle sensor, such as an encoder, attached to the pinion and gear shaft. The transmission error,  $\theta_e$ , of the gear pair is calculated by Formula (F.6):

$$\theta_e = \theta_2 - \left( \frac{z_1}{z_2} \right) \theta_1 \quad (F.6)$$

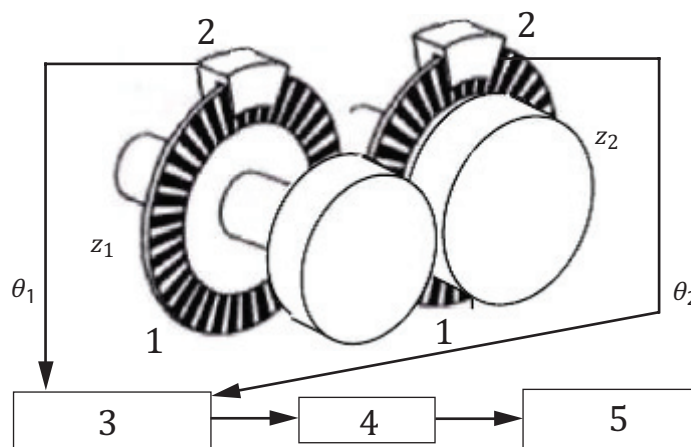

#### Key

- 1 rotary encoder
- 2 reading device
- 3 calculation of transmission error
- 4 filtering
- 5 fourier transform

**Figure F.1 — Schematic view of single flank tester**

The recommended minimum number of measurement points to evaluate single flank parameter is 30 points per tooth. Then, the data are filtered and Fourier transformed. The example of transmission wave form shown in [Figure F.2](#) has the complex shape caused by the cumulative deviation of pinion and gear.

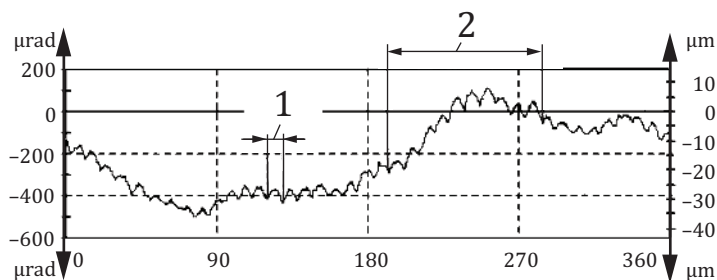

**Key**

- 1 tooth pitch
- 2 one revolution of pinion

**Figure F.2 — An example of transmission error**

The small waves within one pitch are caused by tooth form deviation. [Figure F.3](#) shows the high-pass filtered deviation waves with the tooth pitch period corresponding to the variety of tooth form deviations. Additionally, the minimum and maximum value of the single flank composite tooth mesh component,  $f_{is, \min}$  and  $f_{is, \max}$ , are indicated. [Figure F.4](#) shows the Fourier transformed deviations. Sharp peaks can be seen at the mesh frequency and at the second order mesh frequency.

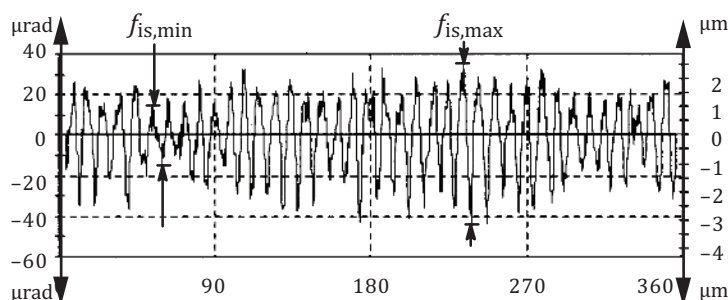

**Figure F.3 — High-pass filtered single flank composite deviations**

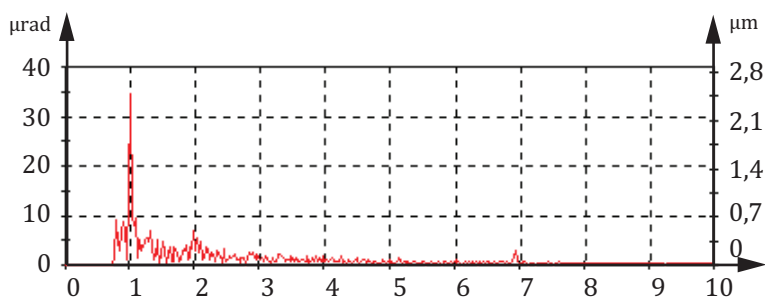

**a) Order of tooth mesh frequency-linear amplitude**

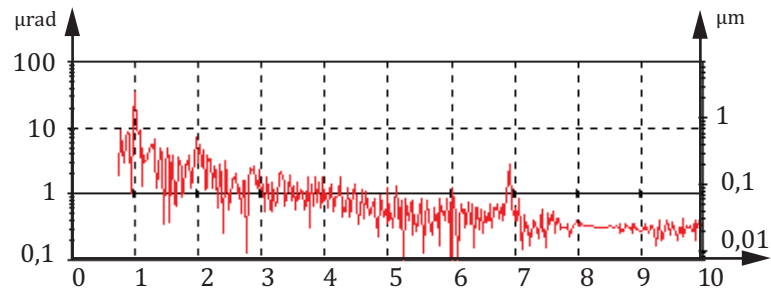

**b) Order of tooth mesh frequency-log amplitude**

**Figure F.4 — Fourier transformed single flank composite deviations**

## Annex G (informative)

### Adjacent pitch difference, $f_u$

#### G.1 Adjacent pitch difference definitions

##### G.1.1 Individual adjacent pitch difference, $f_{ui}$

The individual adjacent pitch difference,  $f_{ui}$  (no algebraic sign), is the difference between the actual measured values of two consecutive individual single pitches of right or left flanks. It is equal to the difference between the individual single pitch deviations of two consecutive pitches (see [Figure G.1](#)).

$$f_{ui(n)} = \left| f_{pi(n)} - f_{pi(n-1)} \right| \quad (G.1)$$

##### G.1.2 Adjacent pitch difference, $f_u$

The adjacent pitch difference,  $f_u$ , is the maximum of the values of individual adjacent pitch difference,  $f_{ui}$ .

#### G.2 Tolerance value

The adjacent pitch difference tolerance,  $f_{uT}$ , shall be calculated using Formula (G.2):

$$f_{uT} = \sqrt{2} f_{pT} \quad (G.2)$$

#### G.3 Guidance to application

The use of adjacent pitch difference shall be agreed upon between the manufacturer and purchaser.



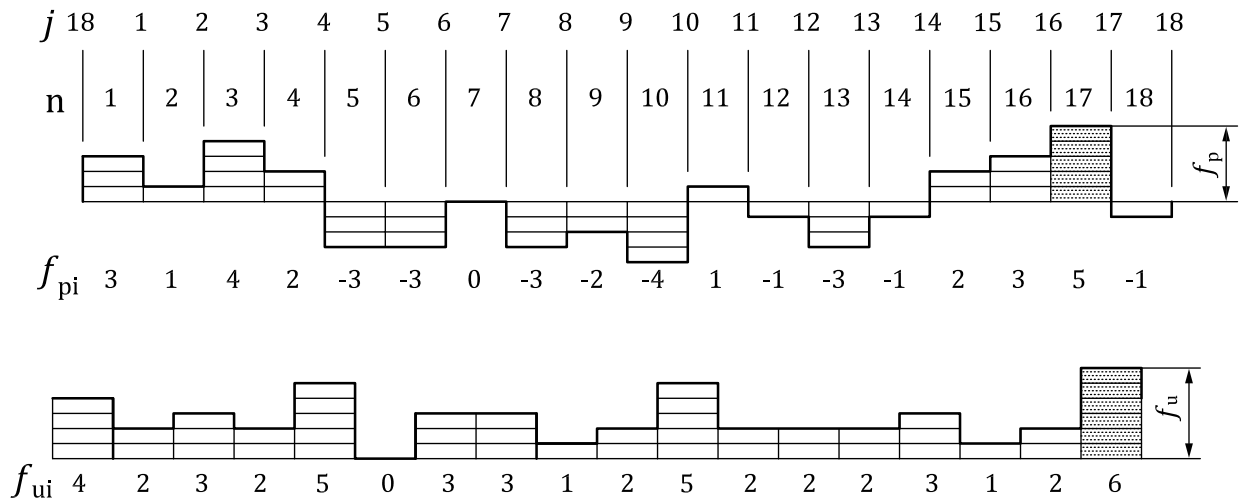

**Key**

- $f_{pi}$  individual single pitch deviation
- $f_{ui}$  individual adjacent pitch difference
- $j$  flank number
- $n$  pitch number

**Figure G.1 — Adjacent pitch difference**

## Bibliography

- [1] ISO/TR 10064-2, *Code of inspection practice — Part 2: Inspection related to radial composite deviations, runout, tooth thickness and backlash*
- [2] ISO/TR 10064-3, *Code of inspection practice — Part 3: Recommendations relative to gear blanks, shaft centre distance and parallelism of axes*
- [3] ISO/TR 10064-4, *Code of inspection practice — Part 4: Recommendations relative to surface texture and tooth contact pattern checking*
- [4] ISO/TR 10064-5, *Code of inspection practice — Part 5: Recommendations relative to evaluation of gear measuring instruments*
- [5] ISO 14253-1, *Geometrical product specifications (GPS) — Inspection by measurement of workpieces and measuring equipment — Part 1: Decision rules for proving conformity or nonconformity with specifications*
- [6] ISO 17485, *Bevel gears — ISO system of accuracy*
- [7] ISO 18653, *Gears — Evaluation of instruments for the measurement of individual gears*
- [8] AGMA 915-1-A02, *Inspection Practices — Part 1: Cylindrical Gears — Tangential Measurements*







# British Standards Institution (BSI)

BSI is the national body responsible for preparing British Standards and other standards-related publications, information and services.

BSI is incorporated by Royal Charter. British Standards and other standardization products are published by BSI Standards Limited.

## About us

We bring together business, industry, government, consumers, innovators and others to shape their combined experience and expertise into standards-based solutions.

The knowledge embodied in our standards has been carefully assembled in a dependable format and refined through our open consultation process. Organizations of all sizes and across all sectors choose standards to help them achieve their goals.

## Information on standards

We can provide you with the knowledge that your organization needs to succeed. Find out more about British Standards by visiting our website at [bsigroup.com/standards](http://bsigroup.com/standards) or contacting our Customer Services team or Knowledge Centre.

## Buying standards

You can buy and download PDF versions of BSI publications, including British and adopted European and international standards, through our website at [bsigroup.com/shop](http://bsigroup.com/shop), where hard copies can also be purchased.

If you need international and foreign standards from other Standards Development Organizations, hard copies can be ordered from our Customer Services team.

## Subscriptions

Our range of subscription services are designed to make using standards easier for you. For further information on our subscription products go to [bsigroup.com/subscriptions](http://bsigroup.com/subscriptions).

With **British Standards Online (BSOL)** you'll have instant access to over 55,000 British and adopted European and international standards from your desktop. It's available 24/7 and is refreshed daily so you'll always be up to date.

You can keep in touch with standards developments and receive substantial discounts on the purchase price of standards, both in single copy and subscription format, by becoming a **BSI Subscribing Member**.

**PLUS** is an updating service exclusive to BSI Subscribing Members. You will automatically receive the latest hard copy of your standards when they're revised or replaced.

To find out more about becoming a BSI Subscribing Member and the benefits of membership, please visit [bsigroup.com/shop](http://bsigroup.com/shop).

With a **Multi-User Network Licence (MUNL)** you are able to host standards publications on your intranet. Licences can cover as few or as many users as you wish. With updates supplied as soon as they're available, you can be sure your documentation is current. For further information, email [bsmusales@bsigroup.com](mailto:bsmusales@bsigroup.com).

## BSI Group Headquarters

389 Chiswick High Road London W4 4AL UK

## Revisions

Our British Standards and other publications are updated by amendment or revision.

We continually improve the quality of our products and services to benefit your business. If you find an inaccuracy or ambiguity within a British Standard or other BSI publication please inform the Knowledge Centre.

## Copyright

All the data, software and documentation set out in all British Standards and other BSI publications are the property of and copyrighted by BSI, or some person or entity that owns copyright in the information used (such as the international standardization bodies) and has formally licensed such information to BSI for commercial publication and use. Except as permitted under the Copyright, Designs and Patents Act 1988 no extract may be reproduced, stored in a retrieval system or transmitted in any form or by any means – electronic, photocopying, recording or otherwise – without prior written permission from BSI. Details and advice can be obtained from the Copyright & Licensing Department.

## Useful Contacts:

### Customer Services

**Tel:** +44 845 086 9001

**Email (orders):** [orders@bsigroup.com](mailto:orders@bsigroup.com)

**Email (enquiries):** [cservices@bsigroup.com](mailto:cservices@bsigroup.com)

### Subscriptions

**Tel:** +44 845 086 9001

**Email:** [subscriptions@bsigroup.com](mailto:subscriptions@bsigroup.com)

### Knowledge Centre

**Tel:** +44 20 8996 7004

**Email:** [knowledgecentre@bsigroup.com](mailto:knowledgecentre@bsigroup.com)

### Copyright & Licensing

**Tel:** +44 20 8996 7070

**Email:** [copyright@bsigroup.com](mailto:copyright@bsigroup.com)



...making excellence a habit.™