

Hydrometry — Velocity-area methods using current-meters — Collection and processing of data for determination of uncertainties in flow measurement

ICS 17.120.20

National foreword

This British Standard is the UK implementation of ISO 1088:2007. It supersedes BS 3680-3F:1986*ISO 1088:1985 which is withdrawn.

The UK participation in its preparation was entrusted by Technical Committee CPI/113, Hydrometry, to Subcommittee CPI/113/5, Measuring instruments and equipment.

A list of organizations represented on this committee can be obtained on request to its secretary.

This publication does not purport to include all the necessary provisions of a contract. Users are responsible for its correct application.

Compliance with a British Standard cannot confer immunity from legal obligations.

This British Standard was published under the authority of the Standards Policy and Strategy Committee on 31 July 2007

© BSI 2007

ISBN 978 0 580 55460 5

Amendments issued since publication

Amd. No.	Date	Comments

INTERNATIONAL STANDARD

ISO 1088

Third edition
2007-07-01

Hydrometry — Velocity-area methods using current-meters — Collection and processing of data for determination of uncertainties in flow measurement

*Hydrométrie — Méthodes d'exploration du champ des vitesses à l'aide
de moulinets — Recueil et traitement des données pour la
détermination des incertitudes de mesurage du débit*



Reference number
ISO 1088:2007(E)

Contents

Page

Foreword.....	iv
Introduction	v
1 Scope	1
2 Normative references	1
3 Symbols and abbreviated terms	2
4 Types of errors and procedure for estimating the uncertainties in flow measurement.....	3
4.1 Principle.....	3
4.2 Occurrence of error	4
4.3 Sources of error	5
4.4 Determination of the individual components of the uncertainty	6
4.5 Total uncertainty in discharge.....	7
5 Collection and processing of data for the investigation of component uncertainties – type A evaluation of uncertainties.....	8
5.1 Data on the local point velocity.....	8
5.2 Data on the average velocity	9
5.3 Data on the velocity-area method	10
5.4 Integration method	11
5.5 Calibration curves.....	11
5.6 Distance measurements	11
5.7 Depth measurements	12
6 Data processing	12
6.1 General.....	12
6.2 Error-type i.....	13
6.3 Error-type ii — Approximation of mean velocity in the vertical.....	15
6.4 Error-type iii — Limited number of verticals.....	17
Annex A (informative) Characteristics of rivers from which data were collected	21
Annex B (normative) Effect of increasing measuring time on uncertainty.....	26
Annex C (normative) Local point velocity measurements - Report form.....	27
Annex D (normative) Average velocity measurements — Report form	31
Annex E (normative) Velocity-area method — Report form	34
Annex F (informative) Examination of Error Types i, ii, and iii.....	38
Annex G (informative) Uncertainties in velocity-area measurement components.....	41
Annex H (informative) Calculation of the uncertainty in a current-meter gauging.....	45
Bibliography	48

Foreword

ISO (the International Organization for Standardization) is a worldwide federation of national standards bodies (ISO member bodies). The work of preparing International Standards is normally carried out through ISO technical committees. Each member body interested in a subject for which a technical committee has been established has the right to be represented on that committee. International organizations, governmental and non-governmental, in liaison with ISO, also take part in the work. ISO collaborates closely with the International Electrotechnical Commission (IEC) on all matters of electrotechnical standardization.

International Standards are drafted in accordance with the rules given in the ISO/IEC Directives, Part 2.

The main task of technical committees is to prepare International Standards. Draft International Standards adopted by the technical committees are circulated to the member bodies for voting. Publication as an International Standard requires approval by at least 75 % of the member bodies casting a vote.

Attention is drawn to the possibility that some of the elements of this document may be the subject of patent rights. ISO shall not be held responsible for identifying any or all such patent rights.

ISO 1088 was prepared by Technical Committee ISO/TC 113, *Hydrometry*, Subcommittee SC 5, *Instruments, equipment and data management*.

This third edition cancels and replaces the second edition (ISO 1088:1985), which has been revised to incorporate ISO/TR 7178 (based on ISO/DATA No. 2) and edited in accordance with ISO/IEC Guide 98:1995, *Guide to the expression of uncertainty in measurement (GUM)*. This third edition of ISO 1088 also cancels and replaces ISO/TR 7178, all provisions of which have been incorporated into this edition.

Introduction

All measurements of physical quantities are subject to uncertainties, which can be due to biases (systematic errors) introduced in the manufacture, calibration, and maintenance of measurement instruments, or to random scatter caused by a lack of sensitivity of the instruments, and to other sources of error.

During the preparation of the first edition of ISO 748, much discussion was given to the question of the magnitude of errors in measurements, and it was concluded that recommendations could only be formulated on the basis of an analysis of sufficient data. Moreover, it was recognized that to be able to analyze such data statistically, it was essential that the data be collected and recorded on a standardized basis and in a systematic manner, and this recognition led to the preparation of ISO 1088 and ISO/TR 7178.

On the basis of the procedures given in the first editions of ISO 748 (1968) and ISO 1088 (1973), data were subsequently collected and processed from the following rivers (see Annex A for the characteristics of these rivers) and ISO/TR 7178 was accordingly published:

- a) Rivers Ganga, Jalangi, Yamuna, and Visvesvaraya Canal, in India;
- b) River IJssel, in the Netherlands;
- c) Rivers Derwent, Eden, Lambourne, Ouse, Tyne, and Usk in the United Kingdom;
- d) Rivers Columbia and Mississippi, in the United States.

Further data obtained on the Rivers Ganga and Krishna, in India, and the Spey, Tay, Tweed, Tyne, Gala Water, Yarrow Water, Ettrick Water, and the Clyde, in the United Kingdom, were received later, but could not be included in the processing.

The procedures for estimating the component uncertainties and the uncertainty in discharge in this International Standard conform to the ISO/IEC Guide 98, *Guide to the expression of uncertainty in measurement (GUM)*.

Hydrometry — Velocity-area methods using current-meters — Collection and processing of data for determination of uncertainties in flow measurement

1 Scope

This International Standard provides a standard basis for the collection and processing of data for the determination of the uncertainties in measurements of discharge in open channels by velocity-area methods using current-meters.

To determine the discharge in open channels by the velocity-area method, components of the flow (velocity, depth and breadth) need to be measured. The component measurements are combined to compute the total discharge. The total uncertainty in the computed discharge is a combination of the uncertainties in the measured components.

Clause 4 of this International Standard deals with the types of errors and uncertainties involved. Clauses 5 and 6 present a standard procedure to estimate the component uncertainties by the collection and processing of the necessary data.

This International Standard is intended to be applied to velocity-area methods that involve measurement of point velocities at a relatively small number of discrete depths and transverse positions in the flow cross-section, as described in ISO 748. This International Standard is not intended to be applied to measurements made by Acoustic Doppler Velocity Profilers (ADVP) or other instruments that produce essentially continuous velocity profiles of the flow field.

2 Normative references

The following referenced documents are indispensable for the application of this document. For dated references, only the edition cited applies. For undated references, the latest edition of the referenced document (including any amendments) applies.

ISO 748, *Measurement of liquid flow in open channels — Velocity-area methods*

ISO 4363, *Measurement of liquid flow in open channels — Methods for measurement of characteristics of suspended sediment*

ISO 4364, *Measurement of liquid flow in open channels — Bed material sampling*

3 Symbols and abbreviated terms

a	coefficient of linear regression, slope of trend line
b_i	breadth (width) of segment i
d_i	depth at vertical in segment i
L	number of sets of measurements (error type ii)
J	number of measurements per set (error types ii and iii)
k'	time displacement in autocorrelation function (of time interval, etc.)
k	coverage factor for expanded uncertainty (taken as 2, corresponding to a level of confidence of approximately 95 %)
m	number of verticals or sections per measurement cross-section
n	multiple of basic exposure-time for velocity measurement (error type i)
n_i	number of depths in vertical i at which velocity measurements are made
Q	discharge
Q_j	discharge of measurement j in a set of measurements (error type iii)
S_{rel}	standard deviation of the relative mean velocities (error type ii)
S_{F}	mean standard deviation of all measurement sets together due to velocity fluctuations (error type ii)
$S_{\text{F},i}$	standard deviation of sampling error in measurement set i (error type ii)
S_{S}	standard deviation of the sampling error due to the computation rule (error type ii)
S_i	stochastic sampling error of mean velocity in vertical i (error type ii)
$S_{\bar{v},i}$	unobservable random sampling error of mean velocity in vertical i (error type ii)
$S_{\text{S},hd}(m)$	standard deviation of relative error when m verticals are applied (error type iii)
t_i	instant of time of observation i (error type i)
t_0	initial measuring time (basic time interval)
\bar{t}	mean of observation times t_i in a linear trend segment (error type i)
u_i	standard relative (percentage) uncertainty in uncertainty component i
u	standard relative (percentage) combined uncertainty of measurement
U	expanded relative (percentage) uncertainty with coverage factor k
u_{c}	standard relative (percentage) uncertainty due to responsiveness of current-meter
u_{b}	standard relative (percentage) uncertainty in width measurement
u_{d}	standard relative (percentage) uncertainty in depth measurement

u_e	standard relative (percentage) uncertainty due to velocity fluctuations
u_m	standard relative (percentage) uncertainty due to limited number of verticals
u_p	standard relative (percentage) uncertainty due to limited number of depths at which velocity is measured
u_s	standard relative (percentage) uncertainty due to instrument calibration errors
v_i	velocity at time t_i or in vertical i
V_i	actual velocity at time t_i or in vertical i
v'_i	corrected velocity from which trend has been removed (error type i)
$\hat{v}(t)$	trend-line velocity (error type i)
\bar{v}_i	mean velocity in vertical i or at point i ;
\bar{V}_{rel}	mean of the relative mean velocities (error type ii)
$\bar{V}_{rel,j}$	mean relative velocity in the j^{th} profile (error type ii)
$\hat{\mu}_s$	mean sampling error for the entire series of measurement sets (error type ii)
$\mu_{s,i}$	mean sampling error in measurement set i (error type ii)
$\hat{\mu}(m)$	mean relative error when m verticals are applied (error type iii)
σ_F	standard deviation of velocity fluctuations (error type i)

Additional symbols are defined in the text.

Due to the statistical nature of this International Standard, it is necessary to have symbols representing observed values and true values of variables. The symbols therefore might not conform to ISO 772.

4 Types of errors and procedure for estimating the uncertainties in flow measurement

4.1 Principle

The principle of the velocity-area method consists in determining from measurements the distribution of the flow velocity in the cross-section and the area of the cross-section, and using these observations for the computation of the discharge.

The measurements of the velocity are made in a number of verticals. In each vertical the mean velocity is determined from measurements at a selected number of points. The discharge per unit width can be found by multiplying the mean velocity by the depth in the vertical considered.

Each vertical is assumed to be representative of a segment of the cross-sectional area. The selection of the number and location of the verticals determines the width of these segments. Recommendations on the number of verticals required are given in 4.4.3 c).

Assuming that the discharge has remained constant during the measurements, summation of the discharge in the various segments gives the total discharge through the section.

4.2 Occurrence of error

In general, the result of a measurement is only an estimate of the true value of the quantity subjected to measurement. The discrepancy between the true and measured values is the measurement error. The measurement error, which cannot be known, causes an uncertainty about the correctness of the measurement result.

The measurement error is a combination of component errors, which arise during the performance of various elementary operations during the measurement process. For measurements of composite quantities, which depend on several component quantities, the total error of the measurement is a combination of the errors in all component quantities. Determination of measurement uncertainty involves identification and characterization of all components of error, and the quantification and combination of the corresponding uncertainties.

ISO/IEC Guide 98 treats measurement uncertainty using concepts and formulas for probability distributions, expected values, standard deviations, and correlations of random variables. The standard deviation of the measurement error is taken as the quantitative measure of uncertainty.

ISO/IEC Guide 98 does not make use of the traditional categorization of errors as random and systematic. That categorization can be difficult to apply in practice. For example, an error that is systematic in one measurement process might become random in a different process. The essential characteristic of systematic errors is that they are not reduced by averaging of replicate measurements. The guide makes it clear that accurate description of the measurement process and correct mathematical formulation of the uncertainty equations are sufficient to account for the fact that some uncertainty sources are not reduced by averaging of replicate measurements whereas others are reduced, without reliance on the concepts of systematic and random error.

The components of uncertainty are characterized by estimates of standard deviations, which are termed standard uncertainty, with recommended symbol u_i , where i identifies the component in question, and which are equal to the positive square root of the estimated variance, u_i^2 . The uncertainty components are combined using formulas for combination of standard deviations of possibly correlated random variables. The resultant uncertainty, which takes all sources and components of uncertainty into account, is called the combined uncertainty and is denoted as u .

ISO/IEC Guide 98 introduces the concepts of Type A and Type B methods of evaluation of uncertainty to make a distinction between uncertainty evaluation by statistical analysis of replicate measurements and uncertainty evaluation by other (perhaps subjective or judgmental) means. Type A evaluation of uncertainty is by statistical analysis of repeated observations to obtain statistical estimates of the standard deviations of the observations; this evaluation commonly can be carried out automatically during the measurement process by data loggers or other instrumentation. Type B evaluation is by calculation of the standard deviation of an assumed probability distribution based on scientific judgment and consideration of all available information, which might include previous measurement and calibration data and experience or general knowledge of the behaviour and properties of relevant instruments. By proper consideration of correlations, either Type A or Type B method of evaluation can be used for evaluation of either systematic or random uncertainty components.

In this International Standard, all uncertainties are expressed numerically as percentages. Standard uncertainty values thus correspond to percentage coefficients of variation (standard deviation divided by the mean). Expanded uncertainties are explicitly identified as such, and are taken with coverage factor 2, corresponding to a level of confidence of approximately 95 %.

4.3 Sources of error

Theoretically, the discharge can be expressed as

$$Q = \iint v(x,y) dx dy \quad (1)$$

where

Q is the true discharge;

$v(x,y)$ is the velocity field over the width, x , and depth, y , of the cross section.

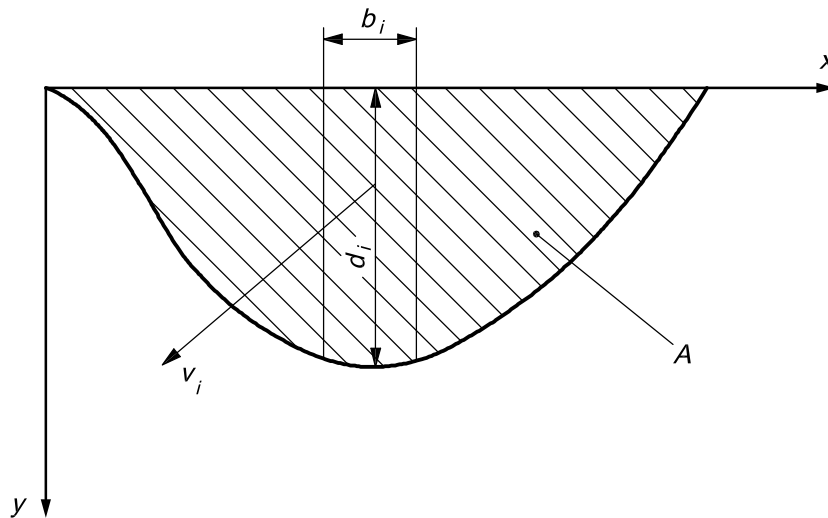

Figure 1 — Definition sketch

In practice, the integral is approximated by the summation

$$Q = \sum_{i=1}^m (b_i d_i \bar{v}_i) \cdot F \quad (2)$$

where

Q is the calculated discharge;

b_i is the width of the i^{th} section;

d_i is the depth of the i^{th} vertical;

\bar{v}_i is the mean velocity in the i^{th} vertical;

F is a factor, conventionally assumed as unity, that relates the discrete sum of the finite number of verticals to the integral of the continuous function over the cross-section (see ISO 748);

m is the number of verticals.

Errors in Q are due to

- a) errors in the measurement of quantities b_i and d_i and of the individual measurements of the velocity necessary for the determination of the average velocity, \bar{v}_i , and
- b) errors in approximation of the integral equation [Equation (1)] by the summation equation [Equation (2)].

4.4 Determination of the individual components of the uncertainty

4.4.1 Uncertainties in width

The measurement of the width between verticals is normally made by measuring distances from a reference point on the bank. When a tape or tag-line is used, or the movement of the wire attached to a trolley is observed, the uncertainty depends on the distance but is usually negligible. Where optical means are used, the uncertainties also depend on the distance measured but can be greater.

Where the distance is measured by electronic means, a constant uncertainty and an uncertainty depending on the distance measured occurs.

The uncertainties result mainly from instrument errors.

4.4.2 Uncertainties in depth

Some uncertainties depend on the type and use of the instrument applied. Such uncertainties are not included in this International Standard.

Uncertainties also arise due to the interpolation of the depth between verticals at which depths are measured.

4.4.3 Uncertainties in the determination of the mean velocity

Apart from instrument calibration errors, the error in the mean flow velocity can be considered as consisting of three independent types of error.

- a) **Error Type i — Pulsations:** The uncertainty due to the limited measuring time of the local point velocity in each vertical. Because of turbulence, the velocity fluctuates continuously over the wet cross-section. The mean velocity at any point, determined from measurement during a certain time interval, is an approximation of the true mean velocity at that particular point. In this International Standard, uncertainties of this nature are referred to as “error type i”. Pulsations in flow are not independent of each other. The velocity at time t_2 is influenced by the velocity at time t_1 . This influence will decrease as the time interval $t_2 - t_1$ increases. The effect of increasing the measuring time on the uncertainty is given in Annex B.
- b) **Error Type ii — Number of points in the vertical:** The uncertainty arising from the use of a limited number of sampling points in a vertical. Computation of the mean velocity in a vertical as an average or weighted average of a number of point velocities results in an approximation of the true mean velocity in the vertical considered. In this International Standard, uncertainties of this nature are referred to as “error type ii”.
- c) **Error Type iii — Number of verticals:** The uncertainty from the limited number of verticals in which velocities are measured. The horizontal velocity profile and bed profile between two verticals have to be determined by interpolation, which introduces an uncertainty (see Annex F). In this International Standard, uncertainties of this nature are referred to as “error type iii”.

NOTE The types of errors referred to in this International Standard are not related to statistical Type i and Type ii errors.

To determine the influence of the distribution of horizontal velocity and depth between the verticals on the total uncertainty in discharge, it is necessary to make a detailed measurement of the cross-section and to locate the verticals for the velocity measurement at intervals of no more than 0,25 m or 1/50 of the total width, whichever is greater.

The values of depth d_i , breadth b_i , and mean velocity \bar{v}_i in the vertical are used to determine the discharge per unit width and discharge through segment i . Summation of the discharges through each segment according to Equation (2) results in an approximation of the true total discharge.

4.5 Total uncertainty in discharge

The uncertainties in the individual components of discharge are expressed as relative standard uncertainties in percent, corresponding to percentage coefficients of variation (standard deviation of error divided by expected value of the measured quantity).

The relative (percentage) combined standard uncertainty in the measurement is given by the following equation (ISO 748):

$$u(Q)^2 = u_m^2 + u_s^2 + \frac{\sum_{i=1}^m \left((b_i d_i \bar{v}_i)^2 (u_{b,i}^2 + u_{d,i}^2 + u_{\bar{v},i}^2) \right)}{\left(\sum_{i=1}^m b_i d_i \bar{v}_i \right)^2} \quad (3)$$

where

- $u(Q)$ is the relative (percentage) combined standard uncertainty in discharge;
- $u_{b,i}, u_{d,i}, u_{\bar{v},i}$ are the relative (percentage) standard uncertainties in the breadth, depth, and mean velocity measured at vertical i ;
- u_s is the relative uncertainty due to calibration errors in the current-meter, breadth measurement instrument, and depth sounding instrument;
- u_m is the relative uncertainty due to the limited number of verticals;
- m is the number of verticals.

The relative uncertainty due to calibration errors, u_s , can be expressed as $u_s = (u_{cm}^2 + u_{bm}^2 + u_{ds}^2)^{1/2}$, where u_{cm} , u_{bm} , and u_{ds} are the relative uncertainties due to calibration errors in the current-meter, breadth measurement instrument, and depth sounding instrument, respectively. An estimated practical value of 1 % can be taken for the value of u_s .

The mean velocity \bar{v}_i at vertical i is the average of point measurements of velocity made at several depths in the vertical. The uncertainty in \bar{v}_i is computed as follows:

$$u(\bar{v}_i)^2 = u_{p,i}^2 + \left(\frac{1}{n_i} \right) (u_{c,i}^2 + u_{e,i}^2) \quad (4)$$

where

- $u_{p,i}$ is the uncertainty in mean velocity \bar{v}_i due to the limited number of depths at which velocity measurements are made at vertical i ;
- n_i is the number of depths in the vertical i at which velocity measurements are made;
- $u_{c,i}$ is the uncertainty in point velocity at a particular depth in vertical i due to variable responsiveness of current-meter;
- $u_{e,i}$ is the uncertainty in point velocity at a particular depth in vertical i due to velocity fluctuations (pulsations) in the stream.

Combining Equations (3) and (4) yields:

$$u(Q)^2 = u_m^2 + u_s^2 + \frac{\sum_{i=1}^m \left((b_i d_i \bar{v}_i)^2 \left(u_{b,i}^2 + u_{d,i}^2 + u_{p,i}^2 + \left(\frac{1}{n_i} \right) (u_{c,i}^2 + u_{e,i}^2) \right) \right)}{\left(\sum_{i=1}^m b_i d_i \bar{v}_i \right)^2} \quad (5)$$

If the measurement verticals are placed so that the segment discharges ($b_i d_i \bar{v}_i$) are approximately equal and if the component uncertainties are equal from vertical to vertical, then Equation (5) simplifies to:

$$u(Q) = \left[u_m^2 + u_s^2 + \left(\frac{1}{m} \right) \left(u_b^2 + u_d^2 + u_p^2 + \left(\frac{1}{n} \right) (u_c^2 + u_e^2) \right) \right]^{\frac{1}{2}} \quad (6)$$

Equation (6) can be used for uncertainty computation for a particular measurement if the segment discharges ($b_i d_i \bar{v}_i$) and the component uncertainties are nearly equal from vertical to vertical. More generally, however, Equation (6) is useful for developing a qualitative understanding of how the various component uncertainties contribute to the total uncertainty discharge measurement. Equation (5) is needed to properly account for the effects of unequal distribution of flow among the segments.

From the above equations, it can be seen that the total standard uncertainty may be reduced by increasing the number of verticals, improving the measurement of the individual components, or both.

It is recommended that, whenever possible, the user shall determine independently the values of the component uncertainties in the above equations. However, for routine gauging, values are given in Annex E of ISO 748:1997 that are the result of many investigations carried out since the publication of the first edition of ISO 748 in 1968. These results are included in Annex G, re-expressed in terms of standard uncertainties (level of confidence approximately 68 %) for conformance with ISO/IEC Guide 98.

It should be noted that since the individual components of uncertainty presented in Annex G are based on statistical analyses of the spread of replicate measurements, on prior observations, rather than on repeated observations during the actual course of the measurement of discharge, they shall be considered as Type B evaluations of uncertainties (see 4.2).

A simplified example of the calculation of the uncertainty in a velocity-area gauging using Equation (6) and the relevant component uncertainties given in Annex G is presented in Annex H.

5 Collection and processing of data for the investigation of component uncertainties – type A evaluation of uncertainties

5.1 Data on the local point velocity

To judge the uncertainty of a single point velocity measurement, the following procedure is required at each of three verticals.

At each point of measurement on a vertical, an uninterrupted observation of the velocity over a period of 2 000 s, or for a period during which the discharge does not change by more than 5 % of the initial value, whichever is the less, shall be made with a current-meter. Every 10 s, a reading of the instrument should be taken, thus giving a total of 200 readings. When pulses are emitted by the current-meter, the number of pulses should be recorded every 10 s; or, when the time is measured at a fixed number of pulses, this time interval should average 10 s. When a continuous record is produced, the complete record should be given and the response characteristics of the electronic instrument stated.

The verticals to be taken for this measurement should be the vertical situated at the deepest point and the verticals situated at places where the depths are 0,6 and 0,3 times the maximum depth, both located on the side of the greater segment of the width from the deepest point.

In each vertical this procedure should be carried out at 0,2, 0,6, and 0,8 and, where possible, at 0,9 times the depth, all measured from the surface. The data shall be obtained, where possible, during the same 2 000 s period.

The data thus obtained shall be indicated in the report format as illustrated in Annex C. In the case of a continuous recorder, the values at intervals of 10 s shall be given, indicating the method of determination.

5.2 Data on the average velocity

5.2.1 General

The average velocity in a vertical can be obtained in various ways. The velocity distribution method, however, is taken as a basis for comparison with the results of other methods generally used or special methods adopted owing to special circumstances.

The following procedure is required for investigating the average velocity in each of the three verticals.

5.2.2 Location of the verticals

The location of the verticals for this measurement shall normally be determined from the known velocity distribution in the gauging cross-section, so as to give velocities which are representative of the whole cross-section.

When the velocity distributions in the gauging cross-section are not known, the verticals taken for this measurement shall be that at maximum depth in the cross-section and at places where the depths are 0,6 and 0,3 times the maximum depth respectively, at the side of the greater segment and not too close to the bank.

5.2.3 Distribution of measuring points in the vertical

Velocity measurements shall be made at the following depths in each vertical:

- 1) immediately below the surface
- 2) at 0,2 times the depth
- 3) at 0,3 times the depth
- 4) at 0,4 times the depth
- 5) at 0,5 times the depth
- 6) at 0,6 times the depth
- 7) at 0,7 times the depth
- 8) at 0,8 times the depth
- 9) at 0,9 times the depth
- 10) near the bed

In channels containing weed growth, great care shall be taken to ensure that measurements made in the vicinity of the bed are not affected by weed fouling the current-meter.

5.2.4 Period of measurement of local point velocities

The period of measurement of local point velocity at any point should be 60 s, or the number of pulses should be that observed in 60 s at 0,6 times the depth.

5.2.5 Number of measurements

The measurements in each of the verticals should be made at least five times, preferably consecutively. Measurements affected by navigation should be indicated.

These sets of observations should be made for various discharges.

5.2.6 Presentation of data

Compilation of data should be made in the format illustrated in Annex D.

The mean velocity should be determined with the use of a planimeter from an adequately large graphical plot (preferably not less than 300 cm²). The type and accuracy of the planimeter should be given, together with the scale of the discharge. The accuracy of the graph paper should be checked.

The velocity profiles should be drawn to a scale in such a way that the maximum velocity and the depth are represented by 0,10 m and 0,20 m respectively.

5.3 Data on the velocity-area method

5.3.1 General

There are two possible ways of determining the uncertainty of the velocity-area method, one requiring special measurements, the other mainly using routine measurements.

Wherever possible, data for both should be produced.

5.3.2 Measurement at 0,6 times the depth

In this method, the continuous profile of the cross-section at the measuring site is required. This can be obtained by echo-sounder measurements or by measuring the depth with a rod at intervals of no more than 0,25 m or 1/50 of the total width, whichever is greater.

The horizontal velocity distribution shall be observed by taking velocity readings at 0,6 times the depth at intervals of no more than 0,25 m or 1/50 of the total width, whichever is greater. The readings of the current-meter shall be made over a period of 120 s.

In addition, readings shall be taken from a reference current-meter at a fixed point, preferably at 0,6 times the depth in the vertical of maximum depth. The readings shall be made every 60 s.

5.3.3 Velocity-distribution method

In this method, the normal procedure for discharge measurement may be used provided the velocity-distribution method or integration method is used for the determination of the average velocity in the vertical.

Readings shall be taken every 60 s, from a reference current-meter at a fixed point, preferably at 0,6 times the depth in the vertical at maximum depth.

In addition to the data on the depth obtained by the normal discharge measurement, a continuous profile of the cross-section at the measuring site shall be provided, as indicated in 5.3.5.

5.3.4 Presentation of data

Compilation of data should be made in the format illustrated in Annex E.

Correction factors in the table on velocity at the reference point can best be based on the average value of velocity at the reference point. In this table, the factors are set as a function of time. To obtain the corrected velocity in the table "Mean velocity at verticals", the velocity column shall be multiplied by this correction factor.

A graphical representation of the cross-section shall be drawn to an adequate scale; the width of the river on the drawing shall be not less than 0,5 m. The representation shall indicate the numerical values of depth at the measuring points when a rod has been used, and shall show the location of the verticals and of the reference current-meter.

A graphical representation of the measured velocity profiles should also be given. This should indicate the numerical values of the velocities at the measuring points.

5.3.5 General data

To facilitate the interpretation of deviations from the normal pattern of the various errors, relevant information on the geometry and morphology of the river concerned is required: for example, a map of scale 1/10 000 of the river approximately 50 times the width of the river upstream and downstream of the measuring site, and a continuous profile of the cross-section at the measurement site.

5.4 Integration method

To determine the standard error in the mean velocity in the verticals obtained by the integration method, a sufficient number of measurements (for example, 50) should be carried out at steady stage in three verticals and the results should be tabulated.

The verticals to be taken for this measurement should be the vertical situated at the maximum depth and the verticals situated at places where the depths are 0,6 and 0,3 times the maximum depth, both located on the side of the greater segment of the width from the deepest point.

The measurements should be repeated for different discharges. Data of a general character can be compiled in a report form similar to that given in Annex C.

5.5 Calibration curves

In connection with the study of the instrument error, calibration curves together with all calibration points should be given, especially data of successive calibrations of a representative current-meter with dates and years of calibration and the intensity of use.

5.6 Distance measurements

No generally applicable method of determining the uncertainty of distance measurements can be given at present. Detailed description of the method of distance measurement should be given, together with the distances involved, and other relevant factors should be given for theoretical examination.

Electronic distance measuring devices give an almost absolutely accurate standard of comparison for distance measurements. Where these instruments are available, independent research programmes, concerning the uncertainty of different methods of distance measurement, may be carried out and the results stated.

The conditions under which the study is carried out should be similar to normal operating conditions in the field.

5.7 Depth measurements

The uncertainty of depth measurement is dependent on the channel conditions and the method of measurement. In the case of lined channels, the bed conditions are not likely to influence the uncertainty of the measurement.

In natural channels, for example rivers, the configuration of the bed varies in the longitudinal as well as in the transverse direction.

In relation to the measuring procedure, it is important to know whether the measurement is carried out from a rigid position or from an anchored launch. In the latter case, the influence of the irregularity of the bed can result in a greater contribution to the total uncertainty of the depth measurement.

Owing to the complex nature of the depth measurements, general directives cannot be given. In carrying out a study, the following considerations give guidance.

- a) In a river with a shifting bed, consecutive measurements at one point should be avoided.
- b) It is advisable to study the bed configuration in the vicinity of the actual measuring point by determining longitudinal and transverse sections.
- c) For all instruments, the uncertainty of the reading in relation to the scale intervals should be determined.
- d) Sounding rods yield errors due to
 - 1) penetration into the bed;
 - 2) deviation from the vertical position;
 - 3) velocity-head pile-up due to velocity stagnation.
- e) Sounding lines (including suspended current-meters) yield errors due to
 - 1) penetration into the bed;
 - 2) deviations from the ideal conditions for which the correction for downstream drift has been calculated;
 - 3) shape and suspension point of the sounding instrument.
- f) Echo-sounders yield errors due to
 - 1) beam width of the transmitted pulse at the bottom;
 - 2) penetration of the pulse into the bed, which is a function of the frequency of the pulse and of bed consistency.

6 Data processing

6.1 General

The method of data processing for the Type A evaluation of component and total uncertainties in the discharge measurement by velocity area methods is given. Although the availability of computers is assumed, it is possible to perform the computation process with less advanced means. Some of these alternatives are indicated.

When processing the data, steady-flow conditions are assumed, which means that the true mean value of each of the various quantities remains constant with time. The existence of non-steady conditions shall be appraised by plotting the data versus time. Any non-steady trends shall be removed from the data before processing (see 6.2.2).

6.2 Error-type i

6.2.1 Finite measuring time and distribution of results

The standard deviation of the fluctuation error due to a finite measuring time is calculated.

It is assumed that the means found from the actual measurements are equal to the hypothetical means over infinite measuring time and that the distribution of the results is of normal (Gaussian) nature.

6.2.2 Correction for non-steady conditions

When the velocity v is plotted against time t , it can be seen from the graph whether the magnitude of v shows any trend which indicates that the conditions during the measurements were not steady. If so, the observed velocities shall be corrected by removing the trend as follows:

$$v'_i = v_i - \hat{v}(t_i) \quad (7)$$

where v'_i is the corrected velocity, v_i the corresponding observed velocity, and $\hat{v}(t_i)$ is the trend velocity at the corresponding time t_i . The corrected velocity v'_i thus is the residual or deviation of the observed velocity from the trend line. If trends are removed, the corrected velocities should be used in subsequent processing; that is, v'_i should be substituted for v_i in the equations in the following sections.

If the trend consists of (or can be approximated by) one or more linear trend segments, the trend line for each segment can be fitted by least squares, with the following result:

$$\hat{v}(t) = \bar{v} + a \cdot (t - \bar{t}) \quad (8)$$

where \bar{v} is the mean of the velocity observations v_i in the linear trend segment, \bar{t} is the mean of the corresponding observation times t_i , and a is the slope of the least squares line, as follows:

$$\bar{v} = \frac{\sum_{i=1}^n v_i}{n} \quad (9)$$

$$\bar{t} = \frac{\sum_{i=1}^n t_i}{n} \quad (10)$$

$$a = \frac{\sum_{i=1}^n (v_i \cdot (t_i - \bar{t}))}{\sum_{i=1}^n (t_i - \bar{t})^2} \quad (11)$$

where the sums extend over the data points in the linear trend segment, and n is the number of data points in the segment.

6.2.3 Standard deviation of velocity fluctuations

The standard deviation of the velocity fluctuations is calculated by using

$$\sigma_F = \sqrt{\frac{\sum_{i=1}^n (v_i - \bar{v})^2}{n - 1}} \quad (12)$$

where n is the number of observations and \bar{v} is the mean of the observed (or corrected) velocities v_i and is computed by using

$$\bar{v} = \frac{\sum_{i=1}^n v_i}{n}$$

The computation procedure can be simplified by using the equation

$$\sigma_F = \sqrt{\frac{\sum_{i=1}^n v_i^2 - n\bar{v}^2}{n-1}} \tag{13}$$

6.2.4 Autocorrelation function

The autocorrelation function can be determined from the equation

$$\rho(k') = \frac{n}{n-k'} \frac{\sum_{i=1}^{n-k'} (v_i - \bar{v})(v_{i+k'} - \bar{v})}{\sum_{i=1}^n (v_i - \bar{v})^2} \tag{14}$$

where

$\rho(k')$ is the autocorrelation function;

k' is the time displacement or lag;

$\sum_{i=1}^n (v_i - \bar{v})^2$ is already known from previous calculations (see Equation 12).

The autocorrelation function is used for the calculation of the standard deviation, as described in 6.2.6.

6.2.5 Effect of measuring time on standard deviation (1)

If no computer is available, the influence of the measuring time (instrument exposure time) on the standard deviation of velocity fluctuations, σ_F , can be determined as follows. For velocity measurements having an initial exposure time t_0 (10 s as specified in 5.1), measurements having an exposure time nt_0 can be computed by averaging n successive velocity observations. If the velocities are averaged in succession, the j^{th} value of the average of n successive readings v_i is calculated from:

$$\bar{V}_{nj} = \frac{\sum_{i=1+(j-1)n}^{nj} v_i}{n} \tag{15}$$

The magnitudes of the \bar{V}_{nj} are used in Equation 12 (substituting \bar{V}_{nj} for v_i and carrying the summation over j from 1 to the total number of \bar{V}_{nj} values) to calculate the standard deviation $\sigma_{F,n}$. This method is less common than the procedure described in 6.2.6.

6.2.6 Effect of measuring time on standard deviation (2) (See also Annex B)

Denoting the standard deviation for an initial measuring (exposure) time t_0 as $\sigma_F(t_0)$ (σ_F in 6.2.3), the standard deviation of the velocity fluctuations for measurements having exposure time nt_0 , $\sigma_F(nt_0)$, can be calculated from:

$$\sigma_F^2(nt_0) = \frac{\sigma_F^2(t_0)}{n} \left[1 + 2 \sum_{k'=1}^n \left(1 - \frac{k'}{n} \right) \rho(k') \right] \tag{16}$$

where $\rho(k')$ is the autocorrelation function at lag k' . This equation characterizes the influence of the measuring time on the accuracy of the point velocity.

6.2.7 Compilation of results

The results of the calculations should be compiled in a table (see the example format below) that gives an impression of the influence of the measuring time on the uncertainty of the point velocities by a comparison of the various standard deviations. (In this table, σ_{Frel} is the relative standard deviation, expressed as a percentage of the mean, \bar{v} .)

Table 1 — Format for compilation of results — Error type i (velocity fluctuations)

Relative depth, d_{rel}	\bar{v} m/s	σ_{F} m/s	σ_{Frel} %	$\rho(1)$	$\rho(2)$...	$\rho(k')$	$\sigma_{\text{Frel}}(t_0)$ %	$\sigma_{\text{Frel}}(2t_0)$ %	...	$\sigma_{\text{Frel}}(nt_0)$ %
0,2											
0,3											
0,4											
0,5											
0,6											
0,7											
0,8											
0,9											

6.3 Error-type ii — Approximation of mean velocity in the vertical

6.3.1 General

The relative standard deviation due to the approximation of the mean velocity in the vertical caused by applying a finite number of point velocities is calculated.

6.3.2 Determination of the standard mean velocity in the vertical

As described in 5.2, the standard mean velocity in the vertical is found by determining the area of the vertical velocity profile with the use of a planimeter and taking the depth into account.

In many cases, if the velocity profile near the surface is not too sharply curved, the mean velocity can be calculated with the use of a trapezium rule applied on the ten unequally spaced point velocities specified in 5.2.3.

$$\bar{V}_i = \left(2V_{\text{surf}} + 3V_{0,2} + 2V_{0,3} + 2V_{0,4} + 2V_{0,5} + 2V_{0,6} + 2V_{0,7} + 2V_{0,8} + 2V_{0,9} + V_{\text{bed}} \right) \frac{1}{20} \quad (17)$$

6.3.3 Computation methods

By the application of computation rules, the mean velocity in the vertical can be approximated by calculation.

Comparison of this approximate mean velocity with the standard mean velocity makes it possible to determine the sampling error for each of the computation methods. Some common formulae are (ISO 748):

- a) $\bar{v} = v_{0,6}$
- b) $\bar{v} = 0,5(v_{0,2} + v_{0,8})$
- c) $\bar{v} = 0,25v_{0,2} + 0,5v_{0,6} + 0,25v_{0,8}$
- d) $\bar{v} = \frac{1}{3}(v_{0,2} + v_{0,6} + v_{0,8})$
- e) $\bar{v} = 0,1v_{\text{surf}} + 0,3v_{0,2} + 0,3v_{0,6} + 0,2v_{0,8} + 0,1v_{\text{bed}}$
- f) $\bar{v} = 0,1v_{\text{surf}} + 0,2v_{0,2} + 0,2v_{0,4} + 0,2v_{0,6} + 0,2v_{0,8} + 0,1v_{\text{bed}}$

The calculated mean velocity is standardized by dividing it by the standard mean velocity obtained according to 6.3.2. The result of the standardization may be called either the standardized mean velocity or the relative mean velocity at the vertical and is denoted $\bar{V}_{\text{rel},j}$.

6.3.4 Sampling error due to velocity fluctuations and computation rule

From the results of a set of measurements of the velocity profile under identical conditions, the mean and the standard deviation of the relative mean velocities are calculated using:

$$\bar{V}_{\text{rel}} = \frac{1}{J} \sum_{j=1}^J \bar{V}_{\text{rel},j} \quad (18)$$

and

$$S_{\text{rel}}^2 = \frac{1}{J-1} \sum_{j=1}^J (\bar{V}_{\text{rel},j} - \bar{V}_{\text{rel}})^2 \quad (19)$$

where

- \bar{V}_{rel} is the mean of the relative mean velocities;
- J is the number of velocity profiles in the set;
- $\bar{V}_{\text{rel},j}$ is the relative mean velocity in the j^{th} profile;
- S_{rel} is the standard deviation of the relative mean velocities.

The sampling error, \hat{S}_j , in profile j due to the computation rule is equal to $(\bar{V}_{\text{rel},j} - 1)$. For a set of J measurements made under identical conditions, the systematic component of the sampling error (bias) is $\mu_s = (\bar{V}_{\text{rel}} - 1)$ and the standard deviation is S_{rel} . The standard deviation is denoted by S_F since it represents the effects of velocity fluctuations under steady flow conditions.

6.3.5 Sampling error due to computation rule

The sampling uncertainty due to the limited number of velocity-measurement points used in the computation rule is isolated from the effects of velocity fluctuations by considering a number of sets of velocity profile measurements. Each set of measurements is made under identical steady flow conditions. The different sets of profiles are collected on different dates under different discharges and possibly at different verticals in the measurement cross-section. If a series of L sets of measurements is considered, each set of measurements i

has an associated mean sampling error $\mu_{s,i}$ and standard deviation $S_{F,i}$. For the series of L sets of measurements, the systematic part of the sampling error can be estimated by

$$\hat{\mu}_s = \frac{1}{L} \sum_{i=1}^L \mu_{s,i} \quad (20)$$

where $\hat{\mu}_s$ represents the bias due to the limited number of points defining the velocity profile in the vertical, taken over the whole series of sets of profile measurements.

The mean standard deviation of all sets of measurements due to velocity fluctuations is determined from

$$S_F^2 = \frac{1}{L} \sum_{i=1}^L S_{F,i}^2 \quad (21)$$

The standard deviation of the sampling error due to the computation rule can be calculated:

$$S_{sv}^2 = \frac{1}{L-1} \sum_{i=1}^L (\mu_{s,i} - \hat{\mu}_s)^2 - \frac{S_F^2}{J} \quad (22)$$

where

S_{sv} is the standard deviation of the sampling error due to the computation rule;

$\mu_{s,i}$ is the sampling error in mean velocity in vertical due to the computation rule in measurement set i ;

$\hat{\mu}_s$ is the mean sampling error for the entire series of measurement sets;

L is the number of sets of measurements in the series;

S_F is the mean standard deviation of all measurement sets together due to velocity fluctuations;

J is the number of measurements in a set.

6.4 Error-type iii — Limited number of verticals

6.4.1 General

The standard deviation of the error of the discharge due to measurement in a limited number of verticals is calculated.

6.4.2 True discharge

Using velocities, from which non-steady trends have been removed, and the corresponding depths and applying the mid-section method, the discharge in a cross-section is calculated according to ISO 748.

For the purpose of determination of error-type iii, this discharge is assumed to be the true discharge.

6.4.3 Omission of verticals

Omitting verticals from use for the calculation of the discharge, the absolute error can be determined by comparison with the true discharge.

The calculation of the discharge shall be based either on the mid-section method or on the mean-section method, as described in ISO 748. The results obtained by use of these methods show differences which are negligible.

The error is standardized by dividing the absolute error by the true discharge. The resultant quantity is called the relative error.

6.4.4 Mean and standard deviations of error

The mean relative error and its standard deviation due to the omission of verticals are determined from a number of sets of measurements in the same cross-section. For a single set of measurements:

$$\hat{\mu}(m) = \frac{1}{J} \sum_{j=1}^J \left[\frac{Q_j(m)}{Q_j} - 1 \right] \quad (23)$$

and

$$S_{s,hd}(m) = \sqrt{\frac{\sum_{j=1}^J \left[\frac{Q_j(m)}{Q_j} - 1 \right]^2}{J-1}} \quad (24)$$

where

- $\hat{\mu}(m)$ is the mean relative error in the discharge due to the limited number of verticals;
- m is the number of verticals considered for the determination of discharge;
- J is the number of measurements in the set;
- $Q_j(m)$ is the calculated discharge applying m verticals using the j^{th} measurement;
- Q_j is the approximated true discharge using the j^{th} measurement;
- $S_{s,hd}(m)$ is the standard deviation of relative error due to error-type iii, applying m verticals.

$S_{s,hd}(m)$ includes the effects of errors due to the limited number of verticals in the definition of both the depth profile ($S_{s,d}^2$) and the horizontal velocity distribution ($S_{s,h}^2$): $S_{s,hd}^2 = S_{s,h}^2 + S_{s,d}^2$.

The mean error or the standard deviation for each set of measurements is plotted against the number of verticals or the mean of groups of verticals considered. From these graphs, the relation between the uncertainty and the number of verticals applied can be deduced.

6.4.5 Criteria applied in choosing the verticals (See also Annex F)

The distances between adjacent verticals on a cross-section can be

- a) equal,
- b) varied, to make the area of all segments equal,
- c) varied, to make the discharge through all segments similar,
- d) varied, to minimize the influence on the discharge of changes in velocity and depth.

Items a) and b) need no explanation.

Item c) can be explained as follows: The true total discharge being 100 %, the discharge per segment will be $100/m$ % when m segments are considered. The cumulative discharge is plotted against the percentage of total discharge, as shown in Figure 2, to establish the position of successive verticals.

As soon as the location of the i^{th} vertical is fixed, and the number of verticals to be applied and therefore also the percentage of the discharge which should flow through each segment are determined, the location of the $(i + 1)^{\text{th}}$ vertical can be found. In Figure 2, an example is given for a discharge of 8,5 %.

Item d) can be explained as follows: Based on the equation for the total discharge according to the mid-section method

$$Q = \sum_{i=1}^m \left(b_i \bar{v}_i d_i + \frac{b_i \bar{v}_i \Delta d_i}{2} + \frac{b_i d_i \Delta \bar{v}_i}{2} + \frac{b_i \Delta d_i \Delta \bar{v}_i}{2} \right) \quad (25)$$

where

Δd_i is the difference in depth in the verticals i and $i + 1$ respectively;

$\Delta \bar{v}_i$ is the difference in velocity in the verticals i and $i + 1$ respectively.

The optimal selection of the verticals as affected by differences in velocity is based on the product $b_i d_i \Delta \bar{v}_i$, and as affected by differences in depth on the product $b_i \bar{v}_i \Delta d_i$.

In the first case the depth in all verticals is used in the calculation of the discharge. In that way the error due to interpolation of the velocity between the verticals can be estimated. In the second case, the error due to interpolation of the depth between the verticals can be determined.

The magnitude of the product indicates the influence on the total discharge of differences in velocity and depth respectively.

Verticals are omitted, starting with the smallest, depending on the magnitude of the product.

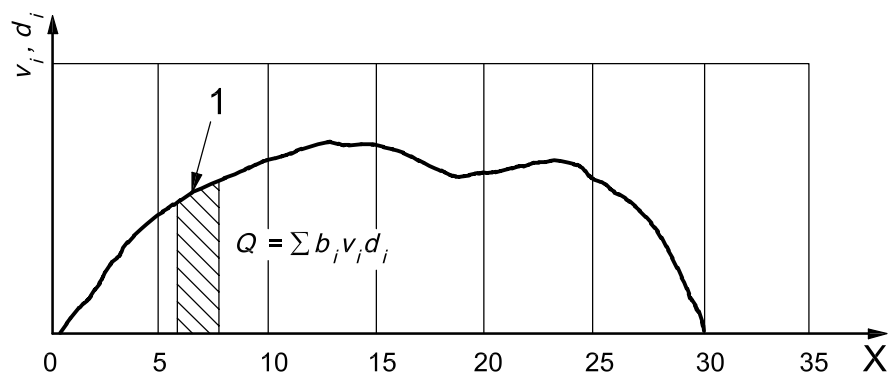

a) $\bar{v}d$ curve

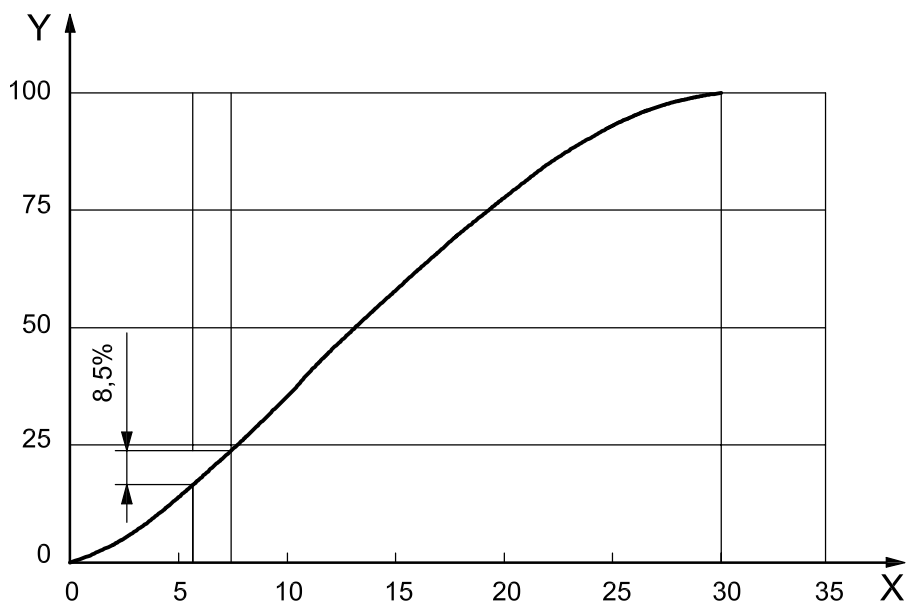

b) Cumulative discharge curve

Key

X number of the vertical from initial point

Y total discharge, %

1 This segment carries 8,5 % total discharge.

Figure 2 — Computation of discharge

Annex A
(informative)

Characteristics of rivers from which data were collected

Table A.1 — Characteristics of rivers from which data were collected

Country	River	Location	Date of measurement	Error type ^a	Discharge m ³ /s	Width m	Mean depth m	Mean velocity m/s	Remarks
USA	Mississippi	Vicksburg	1963-08-13	ii	7 550	590	10,50	1,22	
			1963-08-13	iii	7 540	590	10,50	1,21	
			1963-08-15	i	7 310	590	10,30	1,20	
USA	Columbia	Bridgeport, Washington	1963-08-21	ii	3 000	268	6,31	1,78	
			1963-08-22	i	2 980	268	6,28	1,77	
			1963-08-23	iii	2 970	268	6,27	1,77	
USA	Mississippi	Vicksburg	1964-09-16	ii	5 790	685	8,58	0,98	
			1964-09-17	i	5 750	685	8,58	0,98	
India	Ganga	Varanasi	1966-07-23	ii	1 075	477	9,29	0,24	
			1966-07-27	i	1 051	481	8,35	0,26	
India	Ganga	Varanasi	1966-09-17	ii	3 807	506	10,17	0,74	
			1966-09-20	ii	3 134	506	9,95	0,62	
			1966-09-21	i	3 082	505	9,84	0,62	
India	Jalangi	Swarup Ganj (W.B.)	1966-10-01	iii	1 652	492	9,22	0,36	
			1966-10-10	i	224	110	3,40	0,60	
			1966-10-13	ii	224	110	3,40	0,60	
India	Visvesvaraya Canal	40 km from Krishnaragasagar	1966-10-13	iii	224	110	3,40	0,60	
			1967-03-01	i	42	28	2,44	0,61	
			1967-03-01	ii	42	28	2,44	0,61	
United Kingdom	Ouse	Skelton	1967-03-01	iii	42	28	2,44	0,61	
			1967-06-26	i					General data not available
				ii					

Table A.1 (continued)

Country	River	Location	Date of measurement	Error type ^a	Discharge m ³ /s	Width m	Mean depth m	Mean velocity m/s	Remarks
India	Yamuna	Partappur	1967-09-25	iii	4 610	804	7,85	0,73	
			1967-09-26	i	4 941	801	7,26	0,85	
			1967-09-27	iii	3 658	797	6,71	0,68	
India	Yamuna	Partappur	1967-09-28	i	3 214	793	6,47	0,63	
			1968-04-25 to 1968-05-08	i-ii	472 to 657	479 to 488	1,98 to 2,30	0,50 to 0,58	Data not processed
The Netherlands	IJssel	Doesburg km 902,630	1968-10-16	ii	535	104	4,74	1,09	
			1968-10-17	i	466	108	4,62	0,93	
			1968-10-18	iii	558	115	4,74	1,02	
The Netherlands	IJssel	Doesburg km 902,630	1968-11-04	ii	299	98	3,53	0,86	
			1968-11-06	i	294	98	3,47	0,87	
			1968-11-06	iii	271	98	3,47	0,80	
The Netherlands	IJssel	Doesburg km 902,630	1968-12-09	ii	195	86	3,15	0,72	
			1968-12-10	i	163	86	2,79	0,68	
			1968-12-11	iii	159	86	2,76	0,66	
United Kingdom	Usk	Llandetty	1969-02-26	i	11	31	1,80	0,33	
			1969-02-26	ii					
			1969-02-26	iii	20	31	1,69	0,36	
United Kingdom	Lambourn	Hunt's Green	1969-03-21	i	3	7	0,50	0,72	
United Kingdom	Lambourn	Hunt's Green	1969-03-28	i	3	7	0,50	0,71	
			1969-03-28	iii	3	7	0,50	0,71	

Table A.1 (continued)

Country	River	Location	Date of measurement	Error type ^a	Discharge m ³ /s	Width m	Mean depth m	Mean velocity m/s	Remarks
The Netherlands	IJssel	Doesburg km 902,630	1969-03-31	ii	370	100	3,84	0,96	
			1969-04-01	i	377	100	3,92	0,96	
			1969-04-02	iii	385	103	4,13	0,78	
United Kingdom	Lambourn	Hunt's Green	1969-04-01	iii	3	7	0,54	0,66	
			1969-04-03	i	3	7	0,54	0,64	
			1969-04-03	ii	3	7	0,54	0,64	
United Kingdom	Derwent	Draycott	1969-04-23	i					General data not available
			1969-04-23	ii					
			1969-04-28	iii	32	25	0,97	1,16	
The Netherlands	IJssel	Doesburg km 902,630	1969-04-28	i	665	114	5,10	1,14	
United Kingdom	Tyne	Bywell	1969-05-14	i	34	65	1,40	0,37	
			1989-05-14	ii	34	65	1,40	0,37	
United Kingdom	Eden	Sheepmount Carlisle	1969-05-15	i	39	56	1,23	0,57	
			1969-05-15	ii	39	56	1,23	0,57	
			1969-05-15	iii	39	56	1,23	0,57	
United Kingdom	Tyne	Bywell	1969-05-19	ii					Data not processed
			1969-05-19	iii	38	65	1,45	0,41	Data not processed
			1969-05-20	i	50	65	1,35	0,34	Data not processed
India	Ganga	Varanasi	1969-10-09	i	4 845	521	13,58	0,69	Data not processed
			1969-10-11	ii	3 734	513	12,48	0,58	Data not processed
			1969-10-10	iii	3 422	515	13,07	0,51	Data not processed

Table A.1 (continued)

Country	River	Location	Date of measurement	Error type ^a	Discharge m ³ /s	Width m	Mean depth m	Mean velocity m/s	Remarks
United Kingdom	Gala Water	Galashiels	1969-10-30	i	0,7	13,4	0,50	0,10	Data not processed
United Kingdom	Yarrow Water	Philiphauth	1969-11-07	i	5,6	19,9	0,45	0,63	Data not processed
United Kingdom	Clyde	Daldowie	1970-03-25	i					Data not processed
			1970-03-26	ii		51	0,26	Data not processed	
			1970-03-26	iii	21			Data not processed	
United Kingdom	Ettrick Water	Lindean	1970-05-12	i	3,7	36	0,43	0,24	Data not processed
			1970-05-12	ii	3,9	36	0,44	0,25	Data not processed
			1970-05-12	iii	3,8	36	0,44	0,25	Data not processed
United Kingdom	Spey	Boat of Garten		i				Data not processed	
United Kingdom	Tay	Pitnacree		i				Data not processed	
United Kingdom	Tweed	Norham		i				Data not processed	

^a For an explanation of error types i, ii, and iii, see 4.4.3.

Annex B (normative)

Effect of increasing measuring time on uncertainty

Owing to turbulence, the instantaneous local point velocity is a random phenomenon, and can be regarded as a stochastic process. The most important parameters of this process are the mean, the standard deviations and the autocorrelation function $\rho(k)$, which indicates how quickly interdependences are damped out of a series of measurements.

Because of its dependence on the fluctuation error, the standard deviation decreases more slowly with increasing measuring time than would be the case if it was independent. If the standard deviation of σ_{t_0} and the autocorrelation function $\rho(k)$ are known for a measuring time t_0 , the standard deviation for a measuring time nt_0 , (for $n > 1$) can be calculated from the equation

$$\sigma_{nt_0}^2 = \frac{\sigma_{t_0}^2}{n} \left\{ 1 + 2 \sum_{k=1}^{n-1} \left(1 - \frac{k}{n} \right) \rho(k) \right\}$$

i.e. the standard deviations for measuring times which are n times longer will be greater than

$$\sigma_{nt_0} = \frac{\sigma_{t_0}}{\sqrt{n}}$$

For measuring times greater than t_0 but not equal to nt_0 , the standard deviation can be determined by linear interpolation. Extrapolation to a measuring time shorter than 30 s is not possible unless the autocorrelation function of the instantaneous velocities is known.

Annex C (normative)

Local point velocity measurements - Report form

(See 5.1)

NOTE All values should be converted if necessary to metres and seconds, where appropriate.

Measurements carried out under the responsibility of:

Address:

Please refer inquiries to:

River concerned:

at (location):

Country:

C.1 General data on the river during measuring period

Discharge m ³ /s
Area of cross-section of stream m ²
Average velocity m/s
Water Surface width m
Maximum depth m
Average depth (area/width) m
Slope of stage-discharge curve (sensitivity in steady-stage condition) (m ³ /s)/m
Water temperature °C

C.2 General data on measuring verticals

Measuring verticals	Average velocity	Depth at vertical	Distance from right/left bank
	m/s	m	m
A Maximum depth			
B 0,6 times maximum depth			
C 0,3 times maximum depth			

C.3 Method of velocity measurement (Please tick as appropriate)

- a) Number of pulses, counted every 10 s.
- b) Time (average 10 s) for a constant number of pulses, being for
A: pulses.
B: pulses.
C: pulses.
- c) Continuous velocity record:
Speed of paper at recorder: mm/s
Response characteristics of the electronic instrumentation:
- d) Integration method.

C.4 Measuring apparatus

Type of current-meter (Please give details, such as diameter of propeller and pitch or size of cup, cup distance and number of cups.):

Serial number:

Type of suspension:

Date of calibration (Please add rating-curve and equations for calculation of velocity and indicate whether group calibration or direct calibration is intended. Check whether the water temperature during calibration has been indicated on the rating-curve.):

Method of timing and associated uncertainty:

C.5 Measurements at verticals

C.5.1 Vertical at maximum depth

C.5.1.1 General data

	Depth				Units
	0,2	0,6	0,8	0,9	
Date of measurement					—
Hour of measurement (local time)					—
Water-level at start (local units)					—
Water-level at end (local units)					—
Water-depth during measurement					m
Depth of instrument under surface					m
Average velocity over a period of 2 000 s					m/s
Minimum velocity					m/s
Maximum velocity					m/s
Method of velocity measurement: a) or c) (see C.3)					
Time interval of readings					s
Method b)					
Number of pulses	10	10	10	10	—
Average time interval of readings					s

C.5.1.2 Description of bed conditions

Bed material (size, shape, density)¹⁾:

Bed form (smooth, ripples, dunes):

Sediment transport: yes/no; if yes, type of transport: bed load/suspended load:

Bed roughness (preferably expressed in Chezy coefficient C):

$$C = \frac{\bar{v}}{\sqrt{R_h S}}$$

where

C is the Chezy coefficient;

\bar{v} is the mean velocity;

R_h is the hydraulic mean depth (area of cross-section of stream divided by wetted perimeter);

S is the energy slope.

Remarks:

1) See ISO 4363 and ISO 4364.

C.5.1.3 Velocity observations

a) Velocity at 0,2 depth every 10 s.

Serial No.	Reading	Velocity	Serial No.	Reading	Velocity	Serial No.	Reading	Velocity	Serial No.	Reading	Velocity
1			51			101			151		
.			.			.			.		
.			.			.			.		
.			.			.			.		
.			.			.			.		
.			.			.			.		
50			100			150			200		
Average velocity			Average velocity			Average velocity			Average velocity		
Maximum velocity			Maximum velocity			Maximum velocity			Maximum velocity		
Minimum velocity			Minimum velocity			Minimum velocity			Minimum velocity		
NOTE Please indicate special circumstances influencing the measurements, such as passing of ships.											

b) For measurements at 0,6, 0,8 and 0,9 depths, give details in the format shown at a) above.

C.5.2 Vertical at 0,6 times the maximum depth

Give details in the format shown under C.5.1.

C.5.3 Vertical at 0,3 times the maximum depth

Give details in the format shown under C.5.1.

Annex D
(normative)

Average velocity measurements — Report form

(See 5.2)

NOTE All values should be converted if necessary to metres and seconds, where appropriate.

Measurements carried out under the responsibility of:

Address:

Please refer inquiries to:

River concerned:

at (location)

Country:

D.1 General data on the river during measuring period

Discharge m ³ /s
Area of cross-section of stream m ²
Average velocity m/s
Water surface width m
Maximum depth m
Average depth (area/width) m
Slope of stage-discharge curve (sensitivity in steady-stage condition) (m ³ /s)/m
Depth at vertical m
Average velocity on vertical m/s
Distance of vertical from right bank m
Water temperature °C

D.2 Method of velocity measurement (Please tick as appropriate)

- a) Number of pulses, counted every 60 s.
- b) Time (average 60 s at 0,6 depth) for a constant number of pulses, i.e. pulses.
- c) Continuous velocity record:
 Speed of paper at recorder: mm/s
 Response characteristics of the electronic instrumentation:
- d) Integration method.

D.3 Measuring apparatus

Type of current-meter (Please give details, such as diameter of propeller and pitch or size of cup, cup distance and number of cups.):

Serial number:

Type of suspension:

Date of calibration (Please add rating-curve and equations for calculation of velocity and indicate whether group calibration or direct calibration is intended. Check whether the water temperature during calibration has been indicated on the rating-curve.):

D.4 Measurements at verticals

D.4.1 Vertical at maximum depth

D.4.1.1 General data

	1	2	3	4	5	Units
Date of measurement						—
Hour of measurement (local time)						—
Water-level at start (local units)						—
Water level at end (local units)						—
Water-depth during measurement						m
Duration of the local point velocity measurements using method a) or c) (see D.2)	60	60	60	60	60	s
Number of pulses using method b) based on a duration of 60 s at 0,6 depth of the local point velocity measurements						—

D.4.1.2 Description of bed conditions

Bed material (size, shape, density²):

Bed form (smooth, ripples, dunes):

Sediment transport: yes/no; if yes, type of transport - bed load/suspended load:

Bed roughness (preferably expressed in Chezy coefficient, C):

$$C = \frac{\bar{v}}{\sqrt{R_h S}}$$

2) See ISO 4363 and ISO 4364.

where

C is the Chezy coefficient;

\bar{v} is the mean velocity;

R_h is the hydraulic mean depth (area of cross-section of stream divided by wetted perimeter);

S is the energy slope.

Remarks:

D.4.1.3 Velocity observations

Velocities	1		2		3		4		5	
	Reading	Velocity	Reading	Velocity	Reading	Velocity	Reading	Velocity	Reading	Velocity
near surface ^a										
0,2 depth										
0,3 depth										
0,4 depth										
0,5 depth										
0,6 depth										
0,7 depth										
0,8 depth										
0,9 depth										
near bed ^b										
Average velocity determined graphically										
NOTE Please indicate special circumstances influencing the measurements, such as passing of ships.										
^a The observation near the surface has been taken m below the surface.										
^b The observation near the bed has been taken m above the bed.										

D.4.2 Vertical at 0,6 times the maximum depth

Give details in the format shown under D.4.1.

D.4.3 Vertical at 0,3 times the maximum depth

Give details in the format shown under D.4.1.

Annex E
(normative)

Velocity-area method — Report form

(See 5.3.)

NOTE All values should be converted if necessary to metres and seconds, where appropriate.

Measurements carried out under the responsibility of:

Address:

Please refer inquiries to:

River concerned:

at (location)

Country:

E.1 General data on the river during measuring period

Discharge m ³ /s
Area of cross-section of stream m ²
Average velocity m/s
Water surface width m
Maximum depth m
Average depth (area/width) m
Slope of stage-discharge curve (sensitivity in steady-stage condition) (m ³ /s)/m
Water temperature °C

E.2 Method of velocity measurement (Please tick as appropriate)

- a) Number of pulses, counted every 60 s or 120 s.
- b) Time (average 60 s or 120 s at 0,6 depth) for a constant number of pulses, i.e. or pulses.
- c) Continuous velocity record:
 Speed of paper at recorder: mm/s
 Response characteristics of the electronic instrumentation:
- d) Integration method.

E.3 Measuring apparatus

Type of current-meter (Please give details, such as diameter of propeller and pitch or size of cup, cup distance and number of cups.):

Serial number:

Type of suspension:.....

Date of calibration (Please add rating-curve and equations for calculation of velocity and indicate whether group calibration or direct calibration is intended. Check whether the water temperature during calibration has been indicated on the rating-curve.):

E.4 General data on velocity measurement

E.4.1 Velocity observations

		Units
Date of measurement		—
Water-level at start (local units)		—
Water level at end (local units)		—
Number of verticals		—
Duration of the local point velocity measurements using method a) or c) (see E.2):		—
at 0,6 depth measurement	120	s
at reference point	60	s
by velocity distribution method		s
Number of pulses using method b) based on:		
duration of 120 s for the 0,6 depth measurement		—
duration of 60 s for the reference point		—
velocity distribution method		—
Profile of cross-section measured by echo-sounder/rod at intervals of		m

E.4.2 Description of bed conditions

Bed material (size, shape, density)³⁾:

Bed form (smooth, ripples, dunes):

Sediment transport: yes/no; if yes, type of transport - bed load/suspended load:

Bed roughness (preferably expressed in Chezy coefficient, *C*):

$$C = \frac{\bar{v}}{\sqrt{R_h S}}$$

where

C is the Chezy coefficient;

\bar{v} is the mean velocity;

R_h is the hydraulic mean depth (area of cross-section of stream divided by wetted perimeter);

S is the energy slope.

Remarks:

E.5 Method of measurement of mean velocity at verticals (Please tick as appropriate)

0,6 depth measurement.

(Duration of individual velocity measurements 120 s.)

Velocity-distribution method.

(Normal practice; please add procedure.)

Mean velocity at verticals:

Serial No.	Time	Velocity	Corrected velocity	Depth ^a	Serial No.	Time	Velocity	Corrected velocity	Depth ^a
1					26				
.					.				
.					.				
.					.				
.					.				
.					.				
25					50				

^a To be filled in when the velocity-distribution method has been applied.

3) See ISO 4363 and ISO 4364.

Velocity at reference point:

Time ^a	Velocity	Correction factor ^b	Time	Velocity	Correction factor ^b	Time	Velocity	Correction factor ^b

^a Intervals of 60 s.
^b Correction has been made with respect to the velocity at h.

Annex F (informative)

Examination of Error Types i, ii, and iii

To examine the influence of error types i, ii, and iii from the data collected under Annex A, the following procedure was adopted.

Normally, the mean velocity in a vertical is calculated by using one of the existing computational rules. These rules result in an approximation of the “true” mean velocity at a certain moment.

The resulting error is error type ii. Assuming steady flow conditions, and considering the dispersion of a number of measured mean velocities by their standard deviation, it is possible to determine the influence of error type i.

For the data collected under Annex A, the determination of the “true” mean velocity was calculated using ten points (see 5.2.3) with a measuring time of 60 s repeated five times. Using the ten observations, the velocity profile in the vertical can be drawn and the “true” mean velocity determined using a planimeter.

The mean velocities calculated by using computation rules were compared with this assumed “true” mean velocity. The following computational rules were examined:

$$\bar{v} = v_{0,6} \quad (\text{F.1})$$

$$\bar{v} = 0,96v_{0,6} \quad (\text{F.2})$$

$$\bar{v} = 0,5(v_{0,2} + v_{0,8}) \quad (\text{F.3})$$

$$\bar{v} = 0,25v_{0,2} + 0,5v_{0,6} + 0,25v_{0,8} \quad (\text{F.4})$$

$$\bar{v} = 0,4v_{0,2} + 0,3v_{0,6} + 0,25v_{0,8} \quad (\text{F.5})$$

$$\bar{v} = 1/3(v_{0,2} + v_{0,6} + v_{0,8}) \quad (\text{F.6})$$

$$\bar{v} = 1/4(v_{0,2} + v_{0,4} + v_{0,7} + v_{0,9}) \quad (\text{F.7})$$

$$\bar{v} = 0,1v_{\text{surf.}} + 0,3v_{0,2} + 0,3v_{0,6} + 0,2v_{0,8} + 0,1v_{\text{bed}} \quad (\text{F.8})$$

$$\bar{v} = 1/6(v_{\text{surf.}} + v_{0,2} + v_{0,4} + v_{0,6} + v_{0,8} + v_{\text{bed}}) \quad (\text{F.9})$$

$$\bar{v} = 0,1v_{\text{surf.}} + 0,2v_{0,2} + 0,2v_{0,4} + 0,2v_{0,6} + 0,2v_{0,8} + 0,1v_{\text{bed}} \quad (\text{F.10})$$

The results of the examination are shown in Table F.1.

Table F.1

Rule	Number of points	Mean sampling error $\hat{\mu}_s$ %	Standard deviation of sampling error $\hat{\sigma}_{SV}$ %	Root-mean-square (RMS) sampling error $\sqrt{\hat{\mu}_s^2 + \hat{\sigma}_{SV}^2}$ %	Standard deviation of combined sampling and fluctuation error, error types i and ii %
(1)	1	1,6	7,5	7,7	8,2
(2)	1	3,3	4,8	5,9	6,5
(3)	2	2,2	3,4	4,0	4,9
(4)	3	1,9	4,4	4,8	4,8
(5)	3	-0,8	3,3	3,4	3,9
(6)	3	2,0	3,7	4,2	4,2
(7)	4	-0,9	2,2	2,4	3,0
(8)	5	0,2	2,2	2,2	2,7
(9)	6	-1,6	2,5	3,0	2,8
(10)	6	0,9	2,1	2,3	2,4

The non-systematic character of the mean sampling error with respect to zero is taken into account using root-mean-square (RMS) sampling error, which enables comparison with the standard deviation and also mutual comparison of the various rules.

The following conclusions concerning error type ii have been drawn.

- a) The results for a rule differ from river to river. The rules have a more general validity for larger rivers ($Q > 120 \text{ m}^3/\text{s}$) than for smaller rivers ($Q < 120 \text{ m}^3/\text{s}$). The criterion of $120 \text{ m}^3/\text{s}$ was chosen in such a way that both groups were represented by a sufficient number of rivers.
- b) The nature of the velocity profile in the vertical is sufficiently fixed by measurements at four points (rule No. 7). The result can be improved by increasing the total measuring time, either by measurements at more than four points or by increasing the measuring time at each of the four points.

Error type iii is due to the approximation by interpolation of the bed profile and the horizontal velocity distribution between the verticals.

In practice, both factors usually occur simultaneously. The measurement of velocity and depth takes place in a limited number of verticals located in the cross-section. The selection of the number and location of the verticals is mainly based on personal judgment, taking into account the shape of the bed profile in the cross-section.

In general, it is known that the selection of too few verticals can lead to a considerable error in discharge, but the extent of the approximations and the relation with errors of different origin are unknown.

In the investigation of the data collected under Annex A, an attempt was made to enable a comparison between the error involved in the normal (subjective) practice of measurement and the error which remains after optimum selection of the verticals. For this purpose, a number of (objective) criteria were adopted.

The continuous profile of the cross-section was measured and the horizontal velocity distribution observed by readings of velocity every 120 s at 0,6 of the depth on verticals fixed at intervals of not greater than 2 % of the total width. Some of the criteria used in choosing verticals are described in 6.4.5.

In order to determine the influence of the number of verticals on the accuracy achieved, the number of verticals used for the determination of the discharge was decreased successively in a way depending on the criterion under consideration. The results are given in Table F.2 below for three criteria. They show the standard deviation of error type iii deduced from regression curves drawn through the points observed.

Table F.2

Number of verticals	Relative standard deviation of error, %		
	Criterion 1: Bed profile in the cross-section	Criterion 2: Verticals equidistant	Criterion 3: Sections of equal flow
5	7,70		
6	7,00		4,52
10	4,40	2,60	3,35
15	3,02	1,98	2,60
20	2,20	1,65	2,08
25	1,70	1,45	1,76
30	1,28	1,30	1,60
35	1,02		1,55
40	0,80		
45	0,68		

The following conclusions concerning error type iii have been drawn.

- a) Calculating the discharge from a limited number of verticals gives results which are systematically too low.
- b) For large rivers [see a) above], the interpretation of the horizontal velocity profile affects the extent of the error more than the interpolation of the bed profile. The difference, however, is small.
- c) However, for small rivers, the interpolation of the bed profile influences the error much more than the interpolation of the horizontal velocity profile.
- d) Errors in discharge, caused by interpolation of the velocity profile and depth, respectively, are related. This relation is based on the interdependence between velocity and depth in the vertical.
- e) The error in discharge can be decreased considerably by using knowledge of the continuous profile (echogram) when determining the discharge, instead of using only the depth in the verticals where the velocity is observed.

Annex G (informative)

Uncertainties in velocity-area measurement components

G.1 General

The uncertainty values given in this annex are relative standard uncertainties (“one standard deviation” values, level of confidence approximately 68 %), and are expressed as percentages. The values are the result of investigations carried out since the publication of the first edition of ISO 748 in 1968. Nevertheless, it is recommended that each user should determine independently the values of the uncertainties that will apply in a particular case by following the procedures outlined in this International Standard.

Note that use of standard uncertainties is a change from previous editions (1997 and earlier) of this International Standard, ISO/TR 7178, and ISO 748, which reported uncertainties as “two-sigma” values (level of confidence approximately 95 %). For conformity with the ISO/IEC Guide 98, the “two-sigma” values given in Annex E of ISO 748:1997 have been divided by two to obtain the standard uncertainties (“one-sigma” values) given here.

G.2 Uncertainties in width (u_b)

The standard uncertainty in the measurement of width should be no greater than 0,5 %.

As an example, the uncertainty introduced for a particular range finder having a base distance of 800 mm varies approximately as given in Table G.1.

Table G.1 — Example of uncertainties for a range finder
(Standard uncertainties, level of confidence approximately 68 %)

Range of width m	Absolute uncertainty m	Relative uncertainty %
0 to 100	0 to 0,15	0,15
101 to 150	0,15 to 0,25	0,2
151 to 250	0,3 to 0,6	0,25

G.3 Uncertainties in depth (u_d)

For depths up to 0,300 m, the standard uncertainty should not exceed 1,5 %, and for depths over 0,300 m, the uncertainty should not exceed 0,5 %.

As an example, the standard uncertainty in depth in an alluvial river whose depth varied from 2 m to 7 m and where the velocity varied up to 1,5 m/s was, for these conditions, of the order of 0,05 m measured using a suspension cable.

As another example, measurements of depth were taken with a sounding rod up to a depth of 6 m, and beyond that value by a log line with standard air-line and wet-line corrections. These observations were made within the velocity range of 0,087 m/s to 1,3 m/s. Absolute uncertainties (in metres) were determined and relative uncertainties were computed based on the mid-range depth, the results being as given in Table G.2.

Table G.2 — Examples of uncertainties in depth measurements
(Standard uncertainties, level of approximately confidence 68 %)

Range of depth m	Absolute uncertainty m	Relative uncertainty %	Remarks
0,4 to 6	0,02	0,65	With sounding rod.
6 to 14	0,025	0,25	With log-line and air- and wet-line corrections.

NOTE Column 3 relative uncertainties were computed from column 2 absolute uncertainties using mid-range depths 3,2 m and 10 m.

G.4 Uncertainties in determination of the mean velocity

G.4.1 Times of exposure (u_e)

The standard uncertainty in point velocity measurement taken at different exposure times and points in the vertical, shown in Table G.3, are given as a guide and should be verified by the user. The values are given as standard uncertainties in percent, level of confidence approximately 68 %.

Table G.3 — Percentage uncertainties in point velocity measurements due to limited exposure time
(Standard uncertainties, level of confidence approximately 68 %)

Velocity m/s	Point in vertical							
	0,2D, 0,4D or 0,6D				0,8D or 0,9D			
	Exposure time min							
	0,5	1	2	3	0,5	1	2	3
0,050	25	20	15	10	40	30	25	20
0,100	14	11	8	7	17	14	10	8
0,200	8	6	5	4	9	7	5	4
0,300	5	4	3	3	5	4	3	3
0,400	4	3	3	3	4	3	3	3
0,500	4	3	3	2	4	3	3	2
1,000	4	3	3	2	4	3	3	2
over 1,000	4	3	3	2	4	3	3	2

G.4.2 Number of points in the vertical (u_p)

The uncertainty values shown in Table G.4 were derived from many samples of irregular vertical velocity curves. They are given as a guide and should be verified by the user.

Table G.4 — Percentage uncertainties in the measurement of mean velocity at a vertical, due to limited number of points in the vertical
(Standard uncertainties, level of confidence approximately 68 %)

Method of measurement	Uncertainties
	%
Velocity distribution	0,5
5 points	2,5
2 points (0,2 <i>D</i> and 0,8 <i>D</i>)	3,5
1 point (0,6 <i>D</i>)	7,5
surface	15

G.4.3 Rotating-element current-meter rating (u_c)

The uncertainty values shown in Table G.5 are given as a guide and are based on experiments performed in several rating tanks.

Table G.5 — Percentage uncertainties in point velocity measurement due to meter rating error
(Standard uncertainties, level of confidence approximately 68 %)

Velocity measured m/s	Uncertainties	
	%	
	Individual rating	Group or standard rating
0,03	10	10
0,10	2,5	5
0,15	1,25	2,5
0,25	1,0	2,0
0,50	0,5	1,5
over 0,50	0,5	1,0

G.4.4 Number of verticals (u_m)

The uncertainty values shown in Table G.6 are given as a guide and should be verified by the user.

Table G.6 — Percentage uncertainties in the measurement of mean velocity due to the limited number of verticals

(Standard uncertainties, level of confidence approximately 68 %)

Number of verticals	Uncertainties %
5	7,5
10	4,5
15	3,0
20	2,5
25	2,0
30	1,5
35	1
40	1
45	1

Annex H (informative)

Calculation of the uncertainty in a current-meter gauging

H.1 General

Evaluation of the overall uncertainty of a measurement of flow in an open channel will be exemplified by considering the velocity-area method. This example illustrates the computation of uncertainty in a flow (discharge) measurement made by a velocity-area survey using a current-meter.

H.2 Method

The measurement method, briefly, consists of dividing the channel cross-section under consideration into segments by m verticals and measuring the breadth, depth and mean velocity (denoted by b_i , d_i , \bar{v}_i , respectively) associated with each vertical i . The mean velocity at each vertical is computed from point velocity measurements made at each of several depths on the vertical. The flow is computed as follows:

$$Q = F \sum_{i=1}^m b_i d_i \bar{v}_i \quad (\text{H.1})$$

where

Q is the flow (in cubic metres per second);

F is a factor, assumed to be unity, that relates the discrete sum over the finite number of verticals to the integral of the continuous function over the cross-section (see 4.3).

The relative (percentage) combined standard uncertainty in the measurement is given by the following equation:

$$u(Q)^2 = u_m^2 + u_s^2 + \frac{\sum_{i=1}^m (b_i d_i \bar{v}_i)^2 (u_{b,i}^2 + u_{d,i}^2 + u_{v,i}^2)}{\sum_{i=1}^m (b_i d_i \bar{v}_i)^2} \quad (\text{H.2})$$

where

$u(Q)$ is the relative (percentage) combined standard uncertainty in discharge;

$u_{b,i}$, $u_{d,i}$, $u_{v,i}$ are the relative (percentage) standard uncertainties in the breadth, depth and mean velocity measured at vertical i ;

u_s is the uncertainty due to calibration errors in the current-meter, breadth measurement instrument, and depth sounding instrument:

$= (u_{cm}^2 + u_{bm}^2 + u_{ds}^2)^{1/2}$. An estimated practical value of 1% can be taken for this expression;

u_m is the uncertainty due to the limited number of verticals;

m is the number of verticals.

The mean velocity \bar{v}_i at vertical i is the average of point measurements of velocity made at several depths in the vertical. The uncertainty in \bar{v}_i is computed as follows:

$$u(\bar{v}_i)^2 = u_{p,i}^2 + \left(\frac{1}{n_i}\right)(u_{c,i}^2 + u_{e,i}^2) \quad (\text{H.3})$$

where

$u_{p,i}$ is the uncertainty in mean velocity \bar{v}_i due to the limited number of depths at which velocity measurements are made at vertical i ;

n_i is the number of depths in the vertical i at which velocity measurements are made;

$u_{c,i}$ is the uncertainty in point velocity at a particular depth in vertical i due to variable responsiveness of current-meter;

$u_{e,i}$ is the uncertainty in point velocity at a particular depth in vertical i due to velocity fluctuations (pulsations) in the stream.

Combining Equations (H.2) and (H.3) yields:

$$u(Q)^2 = u_m^2 + u_s^2 + \frac{\sum_{i=1}^m (b_i d_i \bar{v}_i)^2 \left(u_{b,i}^2 + u_{d,i}^2 + u_{p,i}^2 + \left(\frac{1}{n_i}\right)(u_{c,i}^2 + u_{e,i}^2) \right)}{\left(\sum_{i=1}^m b_i d_i \bar{v}_i \right)^2} \quad (\text{H.4})$$

If the measurement verticals are placed so that the segment discharges ($b_i d_i \bar{v}_i$) are approximately equal and if the component uncertainties are equal from vertical to vertical, then Equation (H.4) simplifies to:

$$u(Q) = \left[u_m^2 + u_s^2 + \left(\frac{1}{m}\right) \left(u_b^2 + u_d^2 + u_p^2 + \left(\frac{1}{n}\right) (u_c^2 + u_e^2) \right) \right]^{\frac{1}{2}} \quad (\text{H.5})$$

H.3 Worked example

It is required to calculate the uncertainty in a current-meter gauging from the following particulars:

— Number of verticals used in the gauging	20
— Number of points taken in the vertical (0,2 and 0,8)	2
— Average velocity in measuring section	above 0,3 m/s
— Exposure time of current-meter at each of 2 points	3 min
— Rating of current-meter	individual rating

Component uncertainties are obtained for this example from ISO 748:1997 Annex E (reproduced as Annex G in this International Standard). The values of the component uncertainties are expressed as relative standard uncertainties (level of confidence approximately 68 %), in percent.

Note that in the 1997 and previous editions of ISO 748, Annex E reported uncertainties as “two-sigma” values (level of confidence approximately 95 %). For conformity with the ISO/IEC Guide 98, the “two-sigma” values have been divided by two to obtain standard uncertainties (“one-sigma” values).

$$u_m \quad 2,5 \text{ (Table G.6)}$$

$$u_s \quad 1,0 \text{ (see above)}$$

$$u_b \quad 0,5 \text{ (Table G.1)}$$

$$u_d \quad 0,5 \text{ (Table G.2)}$$

$$u_p \quad 3,5 \text{ (Table G.4)}$$

$$u_c \quad 0,9 \text{ (Table G.5)}$$

$$u_e \quad 3,0 \text{ (at 0,2 depth)(Table G.3)}$$

$$3,0 \text{ (at 0,8 depth)(Table G.3)}$$

$$\text{Total } u_e = (3^2 + 3^2)^{1/2} = 4,2$$

Therefore, from Equation (H.5):

$$u(Q) = \left[u_m^2 + u_s^2 + \left(\frac{1}{m} \right) \left(u_b^2 + u_d^2 + u_p^2 + \left(\frac{1}{n} \right) \left(u_c^2 + u_e^2 \right) \right) \right]^{1/2}$$

$$u(Q) = \left[2,5^2 + 1^2 + \left(\frac{1}{20} \right) \left(0,5^2 + 0,5^2 + 3,5^2 + \left(\frac{1}{2} \right) \left(0,9^2 + 4,2^2 \right) \right) \right]^{1/2}$$

giving

$$u(Q) = 2,89 \%, \text{ say } 3 \%$$

Expanded uncertainty, U , coverage factor $k = 2$, approximate level of confidence 95 %:

$$\begin{aligned} U_{(k=2)}(Q) &= ku(Q) \\ &= 2 \times 3 \% \\ &= 6 \% \end{aligned}$$

$$U(Q) = 6 \%$$

Now, if the measured flow is $Q \text{ m}^3/\text{s}$, the result of the measurement is expressed as:

$$Q \text{ m}^3/\text{s} \pm 6 \% \text{ (expanded uncertainty, coverage factor } k = 2, \text{ approximate level of confidence} = 95 \%)$$

NOTE The above uncertainty calculation is a Type B evaluation of uncertainty since the component uncertainties in ISO 748 are based on previous measurements and calibration data.

Bibliography

- [1] ISO/IEC Guide 98, *Guide to the expression of uncertainty in measurement (GUM)*
- [2] ISO 772, *Hydrometric determinations — Vocabulary and symbols*
- [3] ISO 5168, *Measurement of fluid flow — Procedures for the evaluation of uncertainties*
- [4] ISO/TR 7178:1983, *Liquid flow measurement in open channels — Velocity-area methods — Investigation of total error*

BSI — British Standards Institution

BSI is the independent national body responsible for preparing British Standards. It presents the UK view on standards in Europe and at the international level. It is incorporated by Royal Charter.

Revisions

British Standards are updated by amendment or revision. Users of British Standards should make sure that they possess the latest amendments or editions.

It is the constant aim of BSI to improve the quality of our products and services. We would be grateful if anyone finding an inaccuracy or ambiguity while using this British Standard would inform the Secretary of the technical committee responsible, the identity of which can be found on the inside front cover.
Tel: +44 (0)20 8996 9000. Fax: +44 (0)20 8996 7400.

BSI offers members an individual updating service called PLUS which ensures that subscribers automatically receive the latest editions of standards.

Buying standards

Orders for all BSI, international and foreign standards publications should be addressed to Customer Services. Tel: +44 (0)20 8996 9001.
Fax: +44 (0)20 8996 7001. Email: orders@bsi-global.com. Standards are also available from the BSI website at <http://www.bsi-global.com>.

In response to orders for international standards, it is BSI policy to supply the BSI implementation of those that have been published as British Standards, unless otherwise requested.

Information on standards

BSI provides a wide range of information on national, European and international standards through its Library and its Technical Help to Exporters Service. Various BSI electronic information services are also available which give details on all its products and services. Contact the Information Centre.
Tel: +44 (0)20 8996 7111. Fax: +44 (0)20 8996 7048. Email: info@bsi-global.com.

Subscribing members of BSI are kept up to date with standards developments and receive substantial discounts on the purchase price of standards. For details of these and other benefits contact Membership Administration.
Tel: +44 (0)20 8996 7002. Fax: +44 (0)20 8996 7001.
Email: membership@bsi-global.com.

Information regarding online access to British Standards via British Standards Online can be found at <http://www.bsi-global.com/bsonline>.

Further information about BSI is available on the BSI website at <http://www.bsi-global.com>.

Copyright

Copyright subsists in all BSI publications. BSI also holds the copyright, in the UK, of the publications of the international standardization bodies. Except as permitted under the Copyright, Designs and Patents Act 1988 no extract may be reproduced, stored in a retrieval system or transmitted in any form or by any means – electronic, photocopying, recording or otherwise – without prior written permission from BSI.

This does not preclude the free use, in the course of implementing the standard, of necessary details such as symbols, and size, type or grade designations. If these details are to be used for any other purpose than implementation then the prior written permission of BSI must be obtained.

Details and advice can be obtained from the Copyright & Licensing Manager.
Tel: +44 (0)20 8996 7070. Fax: +44 (0)20 8996 7553.
Email: copyright@bsi-global.com.