

Coal cleaning equipment — Performance evaluation

ICS 73.040

National foreword

This British Standard reproduces verbatim ISO 923:2000 and implements it as the UK national standard. It supersedes BS 3620:1963 which is withdrawn.

The UK participation in its preparation was entrusted to Technical Committee PTI/16, Solid mineral fuels, which has the responsibility to:

- aid enquirers to understand the text;
- present to the responsible international/European committee any enquiries on the interpretation, or proposals for change, and keep the UK interests informed;
- monitor related international and European developments and promulgate them in the UK.

A list of organizations represented on this committee can be obtained on request to its secretary.

Cross-references

The British Standards which implement international or European publications referred to in this document may be found in the BSI Standards Catalogue under the section entitled “International Standards Correspondence Index”, or by using the “Find” facility of the BSI Standards Electronic Catalogue.

A British Standard does not purport to include all the necessary provisions of a contract. Users of British Standards are responsible for their correct application.

Compliance with a British Standard does not of itself confer immunity from legal obligations.

Summary of pages

This document comprises a front cover, an inside front cover, the ISO cover page, pages ii to iv, pages 1 to 32, an inside back cover and a back cover.

The BSI copyright notice displayed in this document indicates when the document was last issued.

Amendments issued since publication

Amd. No.	Date	Comments

This British Standard, having been prepared under the direction of the Sector Committee for Materials and Chemicals, was published under the authority of the Standards Committee and comes into effect on 15 September 2000

© BSI 09-2000

ISBN 0 580 36474 7

INTERNATIONAL STANDARD

**ISO
923**

Second edition
2000-05-15

Coal cleaning equipment — Performance evaluation

Équipement pour l'épuration du charbon — Évaluation des résultats



Reference number
ISO 923:2000(E)

Contents

Page

Foreword	iv
1 Scope	1
2 Normative references	1
3 Terms and definitions	1
4 Performance criteria	2
5 Performance parameters	2
6 Performance test procedures	3
7 Analytical procedures	3
8 Expression of performance	3
Annex A (normative) Methods of expressing performance	4
Annex B (normative) Recommendations for standard methods of presenting coal cleaning test data	5
Annex C (informative) Graphs	29

Foreword

ISO (the International Organization for Standardization) is a worldwide federation of national standards bodies (ISO member bodies). The work of preparing International Standards is normally carried out through ISO technical committees. Each member body interested in a subject for which a technical committee has been established has the right to be represented on that committee. International organizations, governmental and non-governmental, in liaison with ISO, also take part in the work. ISO collaborates closely with the International Electrotechnical Commission (IEC) on all matters of electrotechnical standardization.

International Standards are drafted in accordance with the rules given in the ISO/IEC Directives, Part 3.

Draft International Standards adopted by the technical committees are circulated to the member bodies for voting. Publication as an International Standard requires approval by at least 75 % of the member bodies casting a vote.

Attention is drawn to the possibility that some of the elements of this International Standard may be the subject of patent rights. ISO shall not be held responsible for identifying any or all such patent rights.

International Standard ISO 923 was prepared by Technical Committee ISO/TC 27, *Solid mineral fuels*, Subcommittee SC 1, *Coal preparation: Terminology and performance*.

This second edition cancels and replaces the first edition (ISO 923:1975), which has been technically revised.

Annexes A and B form a normative part of this International Standard. Annex C is for information only.

Coal cleaning equipment — Performance evaluation

1 Scope

This International Standard describes the principles and methods for evaluating the performance of equipment used for cleaning operations. Testing and sampling procedures are specified and methods of presenting test results are detailed. Performance parameters are recommended and defined and their determination is formulated, thereby allowing their use in evaluating, comparing and predicting performance levels of cleaning operations.

This International Standard is applicable to the following types of coal cleaning equipment using relative density as the main characteristic for separation:

- a) dense-medium separators;
- b) jigs;
- c) other separators.

2 Normative references

The following normative documents contain provisions which, through reference in this text, constitute provisions of this International Standard. For dated references, subsequent amendments to, or revisions of, any of these publications do not apply. However, parties to agreements based on this International Standard are encouraged to investigate the possibility of applying the most recent editions of the normative documents indicated below. For undated references, the latest edition of the normative document referred to applies. Members of ISO and IEC maintain registers of currently valid International Standards.

ISO 1170, *Coal and coke — Calculation of analyses to different bases.*

ISO 1213-1, *Solid mineral fuels — Vocabulary — Part 1: Terms relating to coal preparation.*

ISO 1953, *Hard coal — Size analysis by sieving.*

ISO 1988, *Hard coal — Sampling.*

ISO 5048, *Continuous mechanical handling equipment — Belt conveyors with carrying idlers — Calculation of operating power and tensile forces.*

ISO 7936, *Hard coal — Determination and presentation of float and sink characteristics — General directions for apparatus and procedures.*

3 Terms and definitions

For the purposes of this International Standard, the terms and definitions given in ISO 1213-1 apply.

4 Performance criteria

The following criteria are used:

- a) the feed rate, expressed on mass and/or volume basis;
- b) reference density of separation;
- c) sharpness of separation;
- d) correctly placed and misplaced material;
- e) ash error and yield error;
- f) the degree of difficulty of separation;
- g) material characteristics.

The above criteria will be influenced by test conditions, which should therefore be fully reported.

Conditions, including feed rate, should be kept uniform, monitored and maintained within prescribed tolerance limits during a test.

Where performance test results are used for prediction, process conditions should be taken into account.

5 Performance parameters

For the standard expression of performance of a cleaning operation, determine the criteria in clause 4 by the following parameters:

- a) the feed rate, expressed on mass and/or volume basis;

Keep the feed rate as uniform as possible throughout the performance test and determine it over the duration of the test by the most accurate method available.

Where the feed to the equipment is by belt conveyor, determine the feed rate in accordance with ISO 5048.

- b) the reference density of separation, preferably expressed as both partition density and equal-errors cut-point (density);
- c) the sharpness of separation expressed in terms of probable error and imperfection;
- d) the distribution of correctly placed and incorrectly placed material in each product, presented graphically with respect to relative density, and the particular value of misplaced material in each product, determined at the reference density of separation;
- e) the ash error expressed as the difference between the actual ash in the cleaned coal and the theoretical ash at the actual yield value;
- f) the yield error expressed as the difference between the actual yield and the theoretical yield at the actual clean-coal ash value;
- g) the degree of difficulty of separation expressed in terms of near-density material (and by other relevant characteristics).

6 Performance test procedures

The equipment to be tested, the feed composition, and the means of handling the feed and products, vary widely. A single International Standard to cover all cases is not applicable. The following general procedures shall be followed.

- a) Samples shall be taken from the feed and from each of the products. The sampling techniques, number of increments and increment mass shall ensure that all samples taken are representative and shall comply with existing International Standards where available. Sampling of coal is covered by ISO 1988 and size analysis of coal is covered by ISO 1953.

To enable checking of results and assessment of the effects of degradation, representative samples should be taken from all relevant streams to and from the equipment to be tested.

- b) It is essential to determine the feed rate and the percentage yield to each of the products on a dry basis in accordance with ISO 1170. This should be achieved in accordance with one of the procedures given below.

Determine the mass of each product by one or more of the following methods, which are listed in order of reliability.

- a) By direct weighing of the whole of each product collected over the duration of the test or through continuous weighing and integration over the duration of the test.
- b) By taking regular timed increments over the duration of the test.
- c) By weighing each product collected simultaneously over a selected period of the test.

NOTE 1 If it is feasible to measure both the mass of the feed (by belt weigher, weigh hopper, flowmeter, etc.) and the mass of the products, this provides a check.

NOTE 2 If the mass of one of the products cannot be obtained, it may be derived from a mass balance between the feed and other product(s).

NOTE 3 Where the solids are conveyed by a fluid, it may be more convenient to make volumetric measurements.

Representative samples should be taken from streams to determine moisture content or concentrations of solids as appropriate, so that results can be reported on a dry basis.

In circumstances that prevent the determination of yields by the above procedures, alternative procedures (e.g. ash balance) may be used.

7 Analytical procedures

The methods and procedures of size analysis and float and sink analysis shall be in accordance with ISO 1953 and ISO 7936, respectively.

The feed sample and each of the product samples should be separated into various particle size fractions depending on the degree of detail required. Because the performance of coal cleaning equipment is usually different for different size particles, the size ranges should be as prescribed in ISO 7936.

8 Expression of performance

Methods for the expression of the results of coal cleaning tests and the performance of the separation processes are given in normative annex A.

For the purpose of meeting the requirements stated in clause 1, no single method suffices by itself.

Normative annex B describes recommended methods for the calculation and tabulation of test results, and informative annex C gives graphical presentations.

Annex A (normative)

Methods of expressing performance

	Formula	Derived from	Remarks
A.1	Separation density a) Partition density b) Equal-errors cut-point (density)	Partition curves M-curves Washability curves	Describes one characteristic of the separation, but does not indicate its accuracy
A.2	Misplaced material	M-curves Washability curves	Measure of quantity of misplaced material (without reference to its quality) at the separation density
A.3	Total of correctly placed material	M-curves Washability curves	Measure of quantity of correctly placed material (without reference to its quality) at the separation density
A.4	Ash error	M-curves Washability curves	Reflects both the quantity and quality of misplaced material in terms of the specific property of coal (percentage of ash) that the separation is designed to control; measures qualitative efficiency
A.5	Yield error	M-curves Washability curves	Reflects both the quantity and quality of misplaced material and measures quantitative efficiency
A.6	Organic efficiency	M-curves Washability curves	Related to yield error but expressed as a percentage
A.7	Error area	Partition curves	Measure of quantity of misplaced material in terms of density
A.8	Partition coefficients	Partition curves	Special applications only
A.9	<i>Écart probable (moyen)</i>	Partition curves	Gives an indication of the quantitative errors inherent in the separating process at a given separation density
A.10	Imperfection	Partition curves	Modification of <i>écart probable (moyen)</i> to include effect of varying separation density. Not used for dense-medium separators
A.11	Yield loss	Product samples	States results without reference to accuracy of separation

NOTE 1 M-curves and washability curves describe graphically the character of the raw coal and of the products, in terms of mass and ash. Partition curves describe only the products in terms of mass and density; they can be constructed without the necessity to determine ash.

NOTE 2 M-curves have wider direct applications than washability curves, especially, for example, in three-product separations. The construction of such curves is described in ISO 7936.

NOTE 3 The *écart probable (moyen)* and imperfection reflect the influence of changes in the separation process rather than in the raw coal, in contrast to the formulae derived from M-curves or washability curves, which reflect changes in the raw coal as well as in the separation process.

NOTE 4 The separation density, although not a measure of efficiency, is an important characteristic of the separation and is essential to any comprehensive statement of the results of a given test.

NOTE 5 The misplaced material and the total of correctly placed material at the separation density, the ash error, the yield error, the organic efficiency and the error area can all be used for guarantee tests and occasional control tests to give an indication of the accuracy of a given separation on a given coal, and hence of economic efficiency; but they are of little value in the prediction of probable results of cleaning a range of coals by one specific process.

NOTE 6 Partition coefficients, *écart probable (moyen)* and imperfection are valuable for the purpose of prediction but do not give an adequate indication of the accuracy of a given separating operation on a particular coal.

Annex B (normative)

Recommendations for standard methods of presenting coal cleaning test data

B.1 Description of the tables

Two sets of tables are required (see clauses B.4 to B.7):

- a) for three-product separation (cleaned coal, middlings and reject);
- b) for two-product separation (cleaned coal and reject).

For convenience, an identical layout has been adopted for both sets of tables but, in those intended for use with two-product separations, the columns that relate only to three-product separation have been left blank to avoid confusion.

Each set of tables is presented in two ways.

- a) Blank tables, to show the method of printing (see Form 1 and Form 3 in clauses B.4 and B.6, respectively).
- b) Tables completed by filling in the figures relating to test results. For example, Form 2 and Form 4 shown in clauses B.5 and B.7 give the results of a test using a Baum jig washer.

NOTE The example described in this annex was carried out prior to the publication of ISO 7936. The particle sizes used therefore are not in accordance with those specified in that International Standard.

For the test described in this example, the washer was supplied with coal sized from 152 mm to 0 mm. The figures used refer to the fraction sized between 12,7 mm and 0,5 mm. The fine material below 0,5 mm was removed from the samples before carrying out float and sink tests, because this fine material presents difficulties in testing. Moreover, the jig is not expected to clean material smaller than 0,5 mm.

For a full analysis of the test, tables similar to those given for the 12,7 mm to 0,5 mm size would be required for the other sizes of the raw coal, in this instance 152 mm to 51 mm, 51 mm to 25,4 mm, and 25,4 mm to 12,7 mm. Such tables would enable the performance on the different sizes to be compared. By adding together the results on the four individual sizes, a further set of tables could be constructed giving cumulative data for the whole of the 152 mm to 0,5 mm coal.

In this test, three products were made: cleaned coal, middlings and reject. The reject is the material removed by the primary reject elevator and the middlings is the reject from the secondary reject elevator. The tables headed "three-product separation" are built up from float and sink tests at various relative densities from 1,30 to 2,20 on samples of each of these three products. Although intervals of 0,1 relative density have been used for the example, different ranges and intervals may be required in other cases.

The figures in the tables headed "two-product separation" have been calculated from these same figures on the assumption that the products from both elevators (i.e. the middlings and the reject) were combined so that there were two products only: cleaned coal and a single reject.

B.2 Expression of efficiency in the three-product separation

Three-product separation may be regarded as a combination of two distinct two-product separations (i.e. a low-density cut and a high-density cut), whether these two stages are in fact carried out in different separating vessels or in different parts of the same vessel.

The diagrams in Figure B.1 illustrate different combinations of the two stages.

Diagram No.

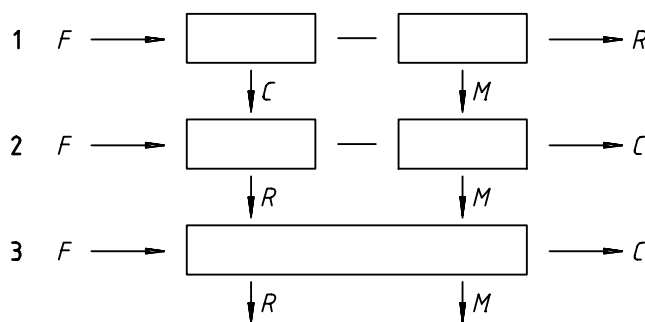

Key

- F* Feed (reconstituted raw coal)
- C* Cleaned coal
- R* Reject
- M* Intermediate product (middlings)

Figure B.1

Diagrams 1 and 2 represent typical arrangements for a two-stage dense-medium separation, the only difference being that the low-density cut comes first in diagram 1 and second in diagram 2, whereas diagram 3 represents a normal three-product jig (or a three-product dense-medium separation). The middlings *M* may be collected as a separate product, or recirculated, or otherwise dealt with, but provided that any recirculated middlings are included in the reconstituted feed *F*, the argument is unaffected.

The efficiency of a three-product separation may be calculated in two different ways:

- a) Method A, by regarding it as two distinct and individual separations, each with its own feed;
- b) Method B, by regarding it as a single comprehensive separation, the feed for which is the reconstituted raw coal.

To calculate the partition coefficients, the appropriate formulae for these two methods, for the combinations of plant illustrated in the diagrams, are as follows:

For diagram 1

- a) Method A:
 - low-density cut $\frac{100 (M + R)}{C + M + R}$
 - high-density cut $\frac{100 R}{C + M + R}$
- b) Method B:
 - low-density cut $\frac{100 (M + R)}{C + M + R}$
 - high-density cut $\frac{100 M}{C + M + R}$

For diagram 2

- | | | |
|--------------|------------------|---------------------------|
| a) Method A: | high-density cut | $\frac{100 R}{C + M + R}$ |
| | low-density cut | $\frac{100 M}{C + M}$ |
| b) Method B: | high-density cut | $\frac{100 R}{C + M + R}$ |
| | low-density cut | $\frac{100 M}{C + M + R}$ |

For diagram 3

- | | | |
|--------------|------------------|---------------------------------|
| a) Method A: | high-density cut | $\frac{100 R}{C + M + R}$ |
| | low-density cut | $\frac{100 M}{C + M}$ |
| b) Method B: | high-density cut | $\frac{100 R}{C + M + R}$ |
| | low-density cut | $\frac{100 (M + R)}{C + M + R}$ |

Although for Method A the formulae are identical for diagrams 2 and 3, in the latter case there is no sharp dividing line between the first and second cuts. The first (high-density) cut separates the reject R from the combination of the cleaned coal C and middlings M , and it is this combination that becomes the feed to the second stage of the separation.

Method A enables the efficiency of each of the two separations to be studied individually, because only the material actually admitted to the separation is included in the calculation. This is of advantage when considering the performance of each machine or stage in the separation process.

Method B does not show up so emphatically the actual performance of the second machine or stage, but by referring each separation back to the reconstituted raw feed it facilitates comparisons of the efficiency of the whole separation process in terms of the results on the original raw coal. (The sequence of operations included in this complete process may include steps not shown in diagrams 1 to 3, for example crushing of the middlings and its recirculation to the feed, which is common in jig washing and may also occur in dense-medium separation.)

It is essential, whenever the efficiency of a three-product separation is expressed (for example, in descriptions of plant and efficiency statements and guarantees), that it be clearly stated which of these two bases has been used for the calculation. To facilitate this, it is proposed that Method A be described as the equipment performance basis, and Method B as the coal performance basis.

Tables B.1 to B.10 for the three-product separations are drawn up on the coal performance basis. When calculations are made on the equipment performance basis, it is recommended that two-product tables be used (one for each stage). It is possible, however, to deduce the results from the three-product table; thus, partition coefficients for the second cut would be calculated on the equipment performance basis as follows:

- for diagram 1 (see Figure B.1 in clause B.2), column (12) would be calculated from (7)/(9) instead of (7)/(10) in Table B.7;
- for diagrams 2 and 3 (see Figure B.1 in clause B.2), column (13) would be calculated from (6)/(8) instead of (9)/(10) in Table B.7.

B.3 Descriptions of the graphs (see annex C)

B.3.1 Introduction

To calculate the efficiency, the data required in clause B.4 (Tables B.1 to B.5) and clause B.6 (Tables B.11 to B.15) should be represented in graphs. Graphs relating to the test results in clause B.5 (Tables B.6 to B.10) and in clause B.7 (Tables B.16 to B.20) are shown in Figures C.1 to C.4. The graphs have been prepared from the data for three-product separation; but the curves for the low-density cut apply to the two-product example.

Figure C.1 has been drawn to such a scale that 0,2 unit on the relative density axis equals 10 % on the partition-coefficient axis. It is proposed to standardize this relation for drawing partition curves, when using (as in Figure C.1) linear coordinates, but similar standard scales for the other curves are not considered to be practicable at present. The curves can also be drawn using coordinates that are other than linear.

The construction and use of the graphs in Figures C.1 to C.4 are explained in B.3.2 to B.3.5.

B.3.2 Partition curves (three-product) (see Figure C.1)

The partition coefficients in columns (12) and (13) in Table B.7 are plotted against the mean of the relative densities shown in Table B.7 for each fraction.

The curve on the right of Figure C.1 represents the high-density cut because it refers to the removal of the final reject.

The table columns from which the coefficients are extracted are shown on each curve.

The relative density at which the curves cross 50 % is by definition the partition density. Similarly, *écart probable* (moyen) (E_{pm}) is defined in terms of the relative densities d_{25} and d_{75} at which the curves cross 25 % and 75 % respectively. The imperfection (I) is derived from these as shown.

B.3.3 Ash error and organic efficiency (see Figure C.2)

The curve in Figure C.2 shows the cumulative mass on the reconstituted feed plotted against the cumulative ash percent, the figures being taken from columns (43) and (45) in Table B.10.

The point X represents the actual yield and ash for the high-density cut (total cleaned coal and middlings), and the point Y represents those for the low-density cut (total cleaned coal).

Regarding point X.

- The actual ash is 5,61 % and the theoretical float and sink ash for the actual yield of 93,4 % as given by the curve is 5,05 %. The ash error is the difference between these two ash percentages.
- The actual yield is 93,40 % at 5,61 % ash. The theoretical float and sink yield for 5,61 % ash is given by the curve as 94,60 %. The organic efficiency is derived from the ratio of these two yields.

Similar considerations apply to point Y.

B.3.4 Correctly placed (and misplaced) material — High-density cut (see Figure C.3)

The two lower curves in Figure C.3 show the amounts of misplaced material in the reject (column 18 in Table B.8) and the cleaned coal plus middlings product (column 17 in Table B.8), the fraction which in this example goes forward for further treatment. The upper curve shows the sum or total of the misplaced material in these two products combined (column 19 in Table B.8). The total amount (percentage) of correctly placed material (100 minus misplaced material) is read from the scale on the right-hand side of the graph.

The equal-errors cut-point (density) is the relative density at which the two lower curves intersect; in this example, this density is 1,770. The partition density is 1,835.

The relative densities of 1,770 and 1,835 correspond respectively to 96,6 % and 96,7 % for the amounts of correctly placed material.

B.3.5 Correctly placed (and misplaced) material — Low-density cut (see Figure C.4)

The same considerations apply as for the high-density cut, the amounts of misplaced materials in each product being plotted from columns (23) and (24) and the total from column (25) in Table B.8. The equal-errors cut-point (density) and the partition densities are 1,400 and 1,505 and the amounts of correctly placed material 89,9 % and 91,0 % respectively.

The curves in Figures C.1 to C.4 have been drawn on the coal performance basis, all yields being expressed as a percentage of the reconstituted raw coal. On the equipment performance basis, the washing operation being regarded as two distinct two-product separations, the construction of the curves follows exactly the same method as for any two-product separation and presents no difficulties. The curves that apply to the high-density cut (Figure C.1: lower curve; Figure C.2: point X; Figure C.3: upper curve) are identical for both bases.

B.4 Form 1 — Tables for three-product separation

Table B.1 — Data required for calculation of efficiency of three/two-product separation

Reference:		Date of test:				Name of plant:					
Test details		Mass				Summary results					
Size of coal analyzed, mm		Raw coal treated	Size analyzed		Total feed to plant		(1) Single cut: Actual products (see note) Cleaned coal Reject				
	Size of feed to plant, mm		t	%	t	%	(1) High-density cut: Cleaned coal + Middlings/Reject (2) Low-density cut: Cleaned coal/Middlings + Reject				
Type of cleaning unit		Products					Separating density		Correctly placed material %		
Rated capacity, t/h		Cleaned coal					(1)	(2)	(1)	(2)	
		Middlings									
Seam(s) treated		Reject					Partition				
							Equal errors				
Actual testing period	h min	Feed rate, t/h				Epm ^b					
Total stoppages	h min	Basis of masses: Dry ^a Air dry ^a As received ^a				Imperfection					
	h min					Ash error					
Net testing time	h min					Organic efficiency		%	%		

NOTE For a two-product separation, the products are named "cleaned coal" and "reject", although the actual products may in fact be cleaned coal and reject or cleaned coal and middlings or middlings and reject.

^a Cross out those that do NOT apply.

^b Epm: Écart probable (moyen).

Table B.2 — Distribution by mass of products and reconstituted feed

Relative density fractions	Analysis by mass			Percentage of feed			Cleaned coal + middlings: high-density cut	Middlings + reject: low-density cut	Reconstituted feed %	Relative density (nominal)	Partition coefficient	
	Cleaned coal %	Middlings %	Reject %	Cleaned coal	Middlings	Reject					High-density cut	Low-density cut
(1)	(2)	(3)	(4)	Percentage of total feed × (2)	Percentage of total feed × (3)	Percentage of total feed × (4)	(5) + (6)	(6) + (7)	(5) + (6) + (7)	(11)	(7)/(10) × 100	(9)/(10) × 100
							(8)	(9)	(10)		(12)	(13)
Totals	100,00	100,00	100,00						100,00	—	—	—

Table B.3 — Correctly placed material (100 % minus misplaced material)

High-density cut				Low-density cut						
Mass % of feed		Relative density	Misplaced material		Mass % of feed		Relative density	Misplaced material		
Cleaned coal + middlings	Reject		Sinks in cleaned coal + middlings	Floats in reject	Total	Cleaned coal		Middlings + reject	Sinks in cleaned coal	Floats in middlings + reject
as (8)	as (7)		↑ Σ (14)	↓ Σ (15)	(17) + (18)	as (5)	as (9)	↑ Σ (20)	↓ Σ (21)	(23) + (24)
(14)	(15)	(16)	(17)	(18)	(19)	(20)	(21)	(23)	(24)	(25)

Licensed copy: Lee Shau Kee Library, HKUST, Version correct as of 03/01/2015, (c) The British Standards Institution 2013

Table B.4 — Ash of products and reconstituted feed

Relative density fractions	Cleaned coal			Middlings			Reject			Reconstituted feed	
	Mass % of feed	Ash %	Quantity of ash	Mass % of feed	Ash %	Quantity of ash	Mass % of feed	Ash %	Quantity of ash	Mass % of feed	Quantity of ash
as (1)	as (5)	Analysis	(27) × (28)	as (6)	Analysis	(30) × (31)	as (7)	Analysis	(33) × (34)	(27) + (30) + (33)	(29) + (32) + (35)
(26)	(27)	(28)	(29)	(30)	(31)	(32)	(33)	(34)	(35)	(36)	(37)
Totals										100,00	
Total cleaned coal (27) + middlings (30)											
Total middlings (30) + reject (33)											

Table B.5 — Reconstituted feed

Relative density fractions	Reconstituted feed			Relative density	Cumulative floats			Cumulative sinks		
	Mass % of feed	Quantity of ash	Ash		Mass % of feed	Quantity of ash	Ash %	Mass % of feed	Quantity of ash	Ash %
as (1)	as (36)	as (37)	(40)/(39)		↓ Σ (39)	↓ Σ (40)	(44)/(43)	↑ Σ (39)	↑ Σ (40)	(47)/(46)
(38)	(39)	(40)	(41)	(42)	(43)	(44)	(45)	(46)	(47)	(48)
Total	100,00									

B.5 Form 2 — Example for three-product separation

Table B.6 — Data required for calculation of efficiency of two/three-product separation

Reference: XTD/41/B		Date of test: 1975-07-16				Name of plant: Britannia Washery						
Test details		Mass				Summary results						
Size of coal analyzed, mm	12,7 mm to 0,5 mm	Raw coal treated	Size analyzed		Total feed to plant		(1) Single cut: Actual products (see note) Cleaned coal Reject					
	Size of feed to plant, mm		152 mm to 0 mm	t	%	t	%	(1) High-density cut: Cleaned coal + Middlings/Reject (2) Low-density cut: Cleaned coal/Middlings + Reject				
Type of cleaning unit		Baum jig	75	100,0	232,0	100,0						
Rated capacity, t/h	75	Products					Separating density		Correctly placed material %			
		Cleaned coal	62,0	82,6	174,3	75,1						
Seam(s) treated	Tiptop	Middlings	8,1	10,8	31,6	13,6	(1)	(2)	(1)	(2)		
		Reject	4,9	6,6	26,1	11,3	Partition		1,835	1,505	96,7	91,0
Actual testing period	3 h 25 min	Feed rate, t/h	67,9				Epm ^b		0,185	0,115		
Total stoppages	0 h 0 min	Basis of masses:	Dry ^a Air dry ^a As received ^a				Imperfection		0,22	0,23		
Net testing time	3 h 25 min					Ash error		0,56 %	1,35 %			
						Organic efficiency		98,7 %	92,6 %			
NOTE For a two-product separation, the products are named "cleaned coal" and "reject", although the actual products may in fact be cleaned coal and reject or cleaned coal and middlings or middlings and reject.												
^a Cross out those that do NOT apply.												
^b Epm: Écart probable (moyen).												

Table B.7 — Distribution by mass of products and reconstituted feed

Relative density fractions	Analysis by mass			Percentage of feed			Cleaned coal + middlings: high-density cut	Middlings + reject: low-density cut	Reconstituted feed %	Relative density (nominal)	Partition coefficient	
	Cleaned coal %	Middlings %	Reject %	Cleaned coal	Middlings	Reject					High-density cut	Low-density cut
(1)	(2)	(3)	(4)	(5)	(6)	(7)	(5) + (6)	(6) + (7)	(5) + (6) + (7)		(7)/(10) × 100	(9)/(10) × 100
Under 1,30	83,34	26,84	3,92	0,826 × (2)	0,108 × (3)	0,066 × (4)	71,72	3,15	71,98	—	0,36	4,39
1,30–1,40	10,50	16,08	2,21	8,67	1,74	0,15	10,41	1,89	10,56	1,35	1,42	17,80
1,40–1,50	3,35	14,43	1,79	2,77	1,56	0,12	4,33	1,68	4,45	1,45	2,70	37,75
1,50–1,60	1,79	18,86	4,27	1,48	2,04	0,28	3,52	2,32	3,80	1,55	7,37	61,05
1,60–1,70	0,30	8,44	8,26	0,25	0,91	0,55	1,16	1,46	1,71	1,65	32,16	85,38
1,70–1,80	0,16	5,63	6,21	0,13	0,61	0,41	0,74	1,02	1,15	1,75	35,65	88,70
1,80–1,90	0,07	3,58	7,47	0,06	0,39	0,49	0,45	0,88	0,94	1,85	52,13	93,62
1,90–2,00	0,07	2,05	8,09	0,06	0,22	0,53	0,28	0,75	0,81	1,95	65,43	92,59
Over 2,00	0,42	4,09	57,78	0,35	0,44	3,81	0,79	4,25	4,60	—	82,83	92,39
Totals	100,00	100,00	100,00	82,60	10,80	6,60	93,40	17,40	100,00	—	—	—

Table B.8 — Correctly placed material (100 % minus misplaced material)

High-density cut				Low-density cut						
Mass % of feed		Relative density	Misplaced material		Mass % of feed		Relative density	Misplaced material		
Cleaned coal + middlings	Reject		Sinks in cleaned coal + middlings	Floats in reject	Cleaned coal	Middlings + reject		Sinks in cleaned coal	Floats in middlings + reject	Total
as (8)	as (7)		↑ Σ (14)	↓ Σ (15)	as (5)	as (9)		↑ Σ (20)	↓ Σ (21)	(23) + (24)
(14)	(15)	(16)	(17)	(18)	(20)	(21)	(22)	(23)	(24)	(25)
71,72	0,26		93,40	0,00				82,60	0,00	82,60
10,41	0,15	1,30	21,68	0,26	68,83	3,15	1,30	13,77	3,15	16,92
4,33	0,12	1,40	11,27	0,41	8,67	1,89	1,40	5,10	5,04	10,14
3,52	0,28	1,50	6,94	0,53	2,77	1,68	1,50	2,33	6,72	9,05
1,16	0,55	1,60	3,42	0,81	1,48	2,32	1,60	0,85	9,04	9,89
0,74	0,41	1,70	2,26	1,36	0,25	1,46	1,70	0,60	10,50	11,10
0,45	0,49	1,80	1,52	1,77	0,13	1,02	1,80	0,47	11,52	11,99
0,28	0,53	1,90	1,07	2,26	0,06	0,88	1,90	0,41	12,40	12,81
0,79	3,81	2,00	0,79	2,79	0,06	0,75	2,00	0,35	13,15	13,50
			0,00	6,60	0,35	4,25		0,00	17,40	17,40

Table B.9 — Ash of products and reconstituted feed

Relative density fractions	Cleaned coal			Middlings			Reject			Reconstituted feed	
	Mass % of feed	Ash %	Quantity of ash	Mass % of feed	Ash %	Quantity of ash	Mass % of feed	Ash %	Quantity of ash	Mass % of feed	Quantity of ash
as (1)	as (5)	Analysis	(27) × (28)	as (6)	Analysis	(30) × (31)	as (7)	Analysis	(33) × (34)	(27) + (30) + (33)	(29) + (32) + (35)
(26)	(27)	(28)	(29)	(30)	(31)	(32)	(33)	(34)	(35)	(36)	(37)
Under 1,30	68,83	1,4	96,36	2,89	1,6	4,64	0,26	1,4	0,36	71,98	101,34
1,30–1,40	8,67	7,6	65,89	1,74	7,7	13,40	0,15	8,9	1,33	10,56	80,62
1,40–1,50	2,77	15,9	44,04	1,56	18,4	28,70	0,12	18,0	2,16	4,45	74,90
1,50–1,60	1,48	28,6	42,33	2,04	30,4	62,02	0,28	28,3	7,92	3,80	112,27
1,60–1,70	0,25	36,6	9,15	0,91	37,0	33,67	0,55	37,8	20,79	1,71	63,61
1,70–1,80	0,13	41,6	5,41	0,61	42,6	25,99	0,41	45,8	18,78	1,15	50,18
1,80–1,90	0,06	46,4	2,78	0,39	49,0	19,11	0,49	54,4	26,66	0,94	48,55
1,90–2,00	0,06	57,8	3,47	0,22	57,5	12,65	0,53	59,9	31,75	0,81	47,87
Over 2,00	0,35	69,2	24,22	0,44	68,8	30,27	3,81	72,3	275,46	4,60	329,95
Totals	82,60	3,56	293,65	10,80	21,34	230,43	6,60	58,4	385,21	100,00	909,29
Total cleaned coal (27) + middlings (30)				93,40	5,61	524,03					
Total middlings (30) + reject (33)							17,40	35,4	615,64		

Table B.10 — Reconstituted feed

Relative density fractions	Reconstituted feed			Relative density	Cumulative floats			Cumulative sinks		
	Mass % of feed	Quantity of ash	Ash		Mass % of feed	Quantity of ash	Ash %	Mass % of feed	Quantity of ash	Ash %
as (1)	as (36)	as (37)	(40)/(39)		↓ Σ (39)	↓ Σ (40)	(44)/(43)	↑ Σ (39)	↑ Σ (40)	(47)/(46)
(38)	(39)	(40)	(41)	(42)	(43)	(44)	(45)	(46)	(47)	(48)
Under 1,30	71,98	101,34	1,41					100,00	909,29	9,09
1,30–1,40	10,56	80,62	7,63	1,30	71,98	101,34	1,41	28,02	807,85	28,83
1,40–1,50	4,45	74,90	16,83	1,40	82,54	181,96	2,20	17,46	727,33	41,66
1,50–1,60	3,80	112,27	29,54	1,50	86,99	256,86	2,95	13,01	652,43	50,15
1,60–1,70	1,71	63,61	37,20	1,60	90,97	369,13	4,07	9,21	540,16	58,65
1,70–1,80	1,15	50,18	43,63	1,70	92,50	432,74	4,68	7,50	476,55	63,54
1,80–1,90	0,94	48,55	51,65	1,80	93,65	482,92	5,16	6,35	426,37	67,14
1,90–2,00	0,81	47,87	59,10	1,90	94,59	531,47	5,62	5,41	377,82	69,84
Over 2,00	4,60	329,95	71,73	2,00	95,40	579,34	6,07	4,60	329,95	71,73
Total	100,00	909,29	9,09							

B.6 Form 3—Tables for two/three-product separation

Table B.11 — Data required for calculation of efficiency of two/three-product separation

Reference:		Date of test:				Name of plant:					
Test details		Mass				Summary results					
Size of coal analyzed, mm		Raw coal treated	Size analyzed		Total feed to plant		(1) Single cut: Actual products (see note) Cleaned coal Reject				
Size of feed to plant, mm			t	%	t	%	(1) High-density cut: Cleaned coal + Middlings/Reject (2) Low-density cut: Cleaned coal/Middlings + Reject				
Type of cleaning unit											
Rated capacity, t/h		Products					Separating density		Correctly placed material %		
		Cleaned coal					(1)	(2)	(1)	(2)	
Seam(s) treated		Middlings					Partition				
		Reject					Equal errors				
Actual testing period	h min	Feed rate, t/h				E_{pm}^b					
Total stoppages	h min	Basis of masses: Dry ^a Air dry ^a As received ^a				Imperfection					
Net testing time	h min					Ash error					
				Organic efficiency		%		%			
NOTE For a two-product separation, the products are named "cleaned coal" and "reject", although the actual products may in fact be cleaned coal and reject or cleaned coal and middlings or middlings and reject.											
^a Cross out those that do NOT apply.											
^b E_{pm} : Écart probable (moyen).											

Table B.12 — Distribution by mass of products and reconstituted feed

Relative density fractions	Analysis by mass			Percentage of feed			Cleaned coal + middlings: high-density cut	Middlings + reject: low-density cut	Reconstituted feed %	Relative density (nominal)	Partition coefficient	
	Cleaned coal %	Middlings %	Reject %	Cleaned coal	Middlings	Reject					High-density cut	Low-density cut
				Percentage of total feed × (2)	Percentage of total feed × (3)	Percentage of total feed × (4)	(5) + (6)	(6) + (7)	(5) + (6) + (7)	(11)	(7)/(10) × 100	(9)/(10) × 100
(1)	(2)	(3)	(4)	(5)	(6)	(7)	(8)	(9)	(10)		(12)	(13)
Totals	100,00	100,00	100,00						100,00	—	—	—

Table B.13 — Correctly placed material (100 % minus misplaced material)

High-density cut				Low-density cut						
Mass % of feed		Relative density	Misplaced material		Mass % of feed		Relative density	Misplaced material		
Cleaned coal + middlings	Reject		Sinks in cleaned coal + middlings	Floats in reject	Total	Cleaned coal		Middlings + reject	Sinks in cleaned coal	Floats in middlings + reject
as (8)	as (7)		$\uparrow \Sigma$ (14)	$\downarrow \Sigma$ (15)	(17) + (18)	as (5)	as (9)	$\uparrow \Sigma$ (20)	$\downarrow \Sigma$ (21)	(23) + (24)
(14)	(15)	(16)	(17)	(18)	(19)	(20)	(21)	(23)	(24)	(25)

Table B.14 — Ash of products and reconstituted feed

Relative density fractions	Cleaned coal			Middlings			Reject			Reconstituted feed	
	Mass % of feed	Ash %	Quantity of ash	Mass % of feed	Ash %	Quantity of ash	Mass % of feed	Ash %	Quantity of ash	Mass % of feed	Quantity of ash
as (1)	as (5)	Analysis	(27) × (28)	as (6)	Analysis	(30) × (31)	as (7)	Analysis	(33) × (34)	(27) + (30) + (33)	(29) + (32) + (35)
(26)	(27)	(28)	(29)	(30)	(31)	(32)	(33)	(34)	(35)	(36)	(37)
Totals										100,00	
Total cleaned coal (27) + middlings (30)											
Total middlings (30) + reject (33)											

Table B.15 — Reconstituted feed

Relative density fractions	Reconstituted feed			Relative density	Cumulative floats			Cumulative sinks		
	Mass % of feed	Quantity of ash	Ash		Mass % of feed	Quantity of ash	Ash %	Mass % of feed	Quantity of ash	Ash %
as (1)	as (36)	as (37)	(40)/(39)		↓ Σ (39)	↓ Σ (40)	(44)/(43)	↑ Σ (39)	↑ Σ (40)	(47)/(46)
(38)	(39)	(40)	(41)	(42)	(43)	(44)	(45)	(46)	(47)	(48)
Totals	100,00									

B.7 Form 4—Example for two/three-product separation

Table B.16 — Data required for calculation of efficiency of two/three-product separation

Reference: XTD/41/B		Date of test: 1975-07-16				Name of plant: Britannia Washery				
Test details		Mass				Summary results				
Size of coal analyzed, mm	12,7 mm to 0,5 mm	Size analyzed	Total feed to plant	(1) Single cut: Actual products (see note) Cleaned coal Reject						
Size of feed to plant, mm	152 mm to 0 mm			t	%	t	%	(1) High-density cut: Cleaned coal + Middlings/Reject (2) Low-density cut: Cleaned coal/Middlings + Reject		
Type of cleaning unit	Baum jig	Raw coal treated	75,0	100,0	232,0	100,0				
Rated capacity, t/h	75	Products					Separating density		Correctly placed material %	
		Cleaned coal	62,0	82,6	174,3	75,1	(1)	(2)	(1)	(2)
Seam(s) treated	Tiptop	Middlings					Partition		1,505	
		Reject	13,0	17,4	57,7	24,9	Equal errors		1,400	
Actual testing period	3 h 25 min	Feed rate, t/h	67,9			E_{pm}^b		0,115		
Total stoppages	0 h 0 min	Basis of masses: Dry ^a Air dry ^a As received ^a				Imperfection		0,23		
Net testing time	3 h 25 min					Ash error		1,35 %		
						Organic efficiency		92,6 %		
NOTE For a two-product separation, the products are named "cleaned coal" and "reject", although the actual products may in fact be cleaned coal and reject or cleaned coal and middlings or middlings and reject.										
^a Cross out those that do NOT apply.										
^b E_{pm} : Écart probable (moyen).										

Table B.17 — Distribution by mass of products and reconstituted feed

Relative density fractions	Analysis by mass			Percentage of feed			Cleaned coal + middlings: high-density cut	Middlings + reject: low-density cut	Reconstituted feed %	Relative density (nominal)	Partition coefficient	
	Cleaned coal %	Middlings %	Reject %	Cleaned coal	Middlings	Reject					High-density cut	Low-density cut
(1)	(2)	(3)	(4)	(5)	(6)	(7)	(5) + (6)	(6) + (7)	(5) + (6) + (7)	(11)	(7)/(10) × 100	(9)/(10) × 100
Under 1,30	83,34		18,15	0,826 × (2)	× (3)	0,174 × (4)	3,15		71,98	?	4,39	
1,30–1,40	10,50		10,82	8,67		1,89			10,56	1,35	17,80	
1,40–1,50	3,35		9,64	2,77		1,68			4,45	1,45	37,75	
1,50–1,60	1,79		13,33	1,48		2,32			3,80	1,55	61,05	
1,60–1,70	0,30		8,37	0,25		1,46			1,71	1,65	85,38	
1,70–1,80	0,16		5,85	0,13		1,02			1,15	1,75	88,70	
1,80–1,90	0,07		5,05	0,06		0,88			0,94	1,85	93,62	
1,90–2,00	0,07		4,34	0,06		0,75			0,81	1,95	92,68	
Over 2,00	0,42		24,45	0,35		4,25			4,60	?	92,39	
Totals	100,00	100,00	100,00	82,60		17,40			100,00	—	—	—

Table B.18 — Correctly placed material (100 % minus misplaced material)

High-density cut				Low-density cut						
Mass % of feed		Relative density	Misplaced material		Mass % of feed		Relative density	Misplaced material		
Cleaned coal + middlings	Reject		Sinks in cleaned coal + middlings	Floats in reject	Cleaned coal	Middlings + reject		Sinks in cleaned coal	Floats in middlings + reject	Total
as (8)	as (7)		↑ Σ (14)	↓ Σ (15)	as (5)	as (9)		↑ Σ (20)	↓ Σ (21)	(23) + (24)
(14)	(15)	(16)	(17)	(18)	(20)	(21)	(22)	(23)	(24)	(25)
					68,83	3,15		82,60	0,00	82,60
					8,67	1,89	1,30	13,77	3,15	16,92
					2,77	1,68	1,40	5,10	5,04	10,14
					1,48	2,32	1,50	2,33	6,72	9,05
					0,25	1,46	1,60	0,85	9,04	9,89
					0,13	1,02	1,70	0,60	10,50	11,10
					0,06	0,88	1,80	0,47	11,52	11,99
					0,06	0,75	1,90	0,41	12,40	12,81
					0,35	4,25	2,00	0,35	13,15	13,50
								0,00	17,40	17,40

Table B.19 — Ash of products and reconstituted feed

Relative density fractions	Cleaned coal			Middlings			Reject			Reconstituted feed	
	Mass % of feed	Ash %	Quantity of ash	Mass % of feed	Ash %	Quantity of ash	Mass % of feed	Ash %	Quantity of ash	Mass % of feed	Quantity of ash
as (1)	as (5)	Analysis	(27) × (28)	as (6)	Analysis	(30) × (31)	as (7)	Analysis	(33) × (34)	(27) + (30) + (33)	(29) + (32) + (35)
(26)	(27)	(28)	(29)	(30)	(31)	(32)	(33)	(34)	(35)	(36)	(37)
Under 1,30	68,83	1,4	96,36				3,15	1,6	4,98	71,98	101,34
1,30–1,40	8,67	7,6	65,89				1,89	7,8	14,73	10,56	80,62
1,40–1,50	2,77	15,9	44,04				1,68	18,4	30,86	4,45	74,90
1,50–1,60	1,48	28,6	42,33				2,32	30,1	69,94	3,80	112,27
1,60–1,70	0,25	36,6	9,15				1,46	37,3	54,46	1,71	63,61
1,70–1,80	0,13	41,6	5,41				1,02	43,9	44,77	1,15	50,18
1,80–1,90	0,06	46,4	2,78				0,88	52,0	45,77	0,94	48,55
1,90–2,00	0,06	57,8	3,47				0,75	59,2	44,40	0,81	47,87
Over 2,00	0,35	69,2	24,22				4,25	71,9	305,73	4,60	329,95
Totals	82,60	33,56	293,65				17,40	35,4	615,64	100,00	909,29
Total cleaned coal (27) + middlings (30)											
Total middlings (30) + reject (33)											

Table B.20 — Reconstituted feed

Relative density fractions	Reconstituted feed			Relative density	Cumulative floats			Cumulative sinks		
	Mass % of feed	Quantity of ash	Ash		Mass % of feed	Quantity of ash	Ash %	Mass % of feed	Quantity of ash	Ash %
as (1)	as (36)	as (37)	(40)/(39)		↓ Σ (39)	↓ Σ (40)	(44)/(43)	↑ Σ (39)	↑ Σ (40)	(47)/(46)
(38)	(39)	(40)	(41)	(42)	(43)	(44)	(45)	(46)	(47)	(48)
Under 1,30	71,98	101,34	1,41					100,00	909,29	9,09
1,30–1,40	10,56	80,62	7,63	1,30	71,98	101,34	1,41	28,02	807,85	28,83
1,40–1,50	4,45	74,90	16,83	1,40	82,54	181,96	2,20	17,46	727,33	41,66
1,50–1,60	3,80	112,27	29,54	1,50	86,99	256,86	2,95	13,01	652,43	50,15
1,60–1,70	1,71	63,61	37,20	1,60	90,79	369,13	4,07	9,21	540,16	58,65
1,70–1,80	1,15	50,18	43,63	1,70	92,50	432,74	4,68	7,50	476,55	63,54
1,80–1,90	0,94	48,55	51,65	1,80	93,65	482,92	5,16	6,35	426,37	67,14
1,90–2,00	0,81	47,87	59,10	1,90	94,59	531,47	5,62	5,41	377,82	69,84
Over 2,00	4,60	329,95	71,73	2,00	95,40	570,34	6,07	4,60	329,95	71,73
					100,00	909,29	9,09			
Totals	100,00	909,29	9,09							

Annex C
(informative)

Graphs

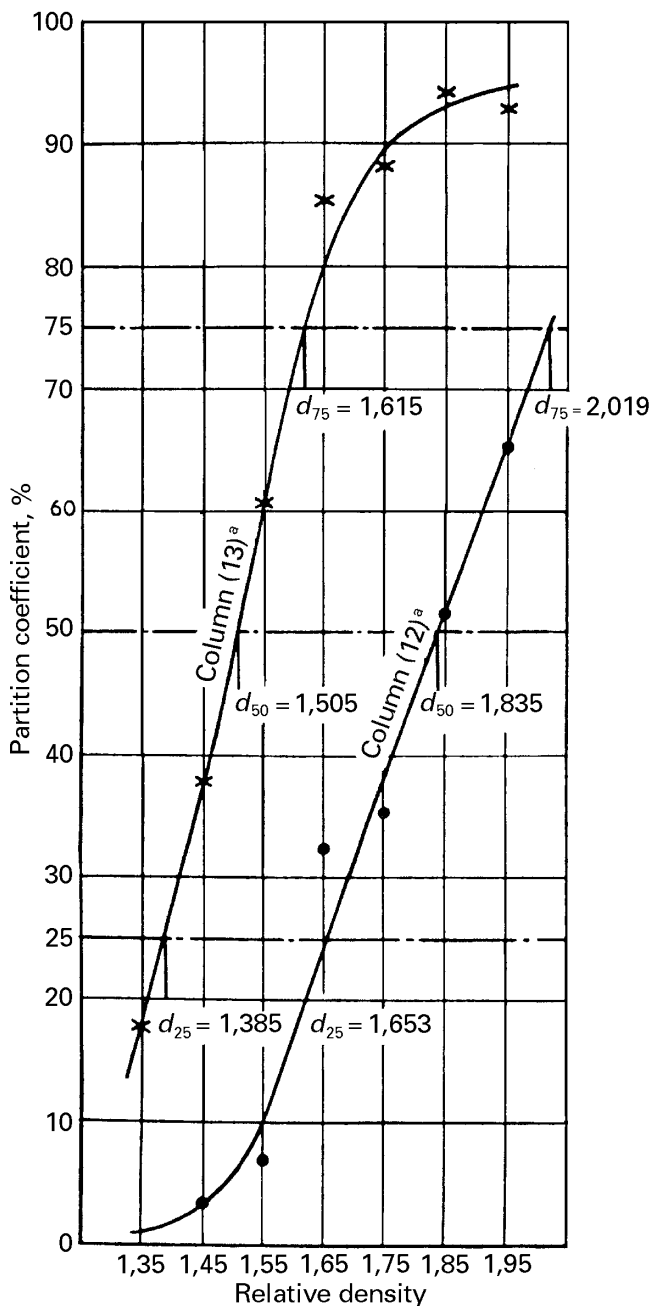

	High-density cut	Low-density cut
Partition density = d_{50}	1,835	1,505
$E_{pm} = \frac{1}{2} (d_{75} - d_{25})$	0,183	0,115
$I = \frac{E_{pm}}{(d_{50} - 1)}$	0,219	0,228
<i>E_{pm}</i> is the écart probable (moyen). <i>I</i> is the imperfection.		

a Column in Table B.7.

Figure C.1 — Partition curves (three-product) (see B.3.2)

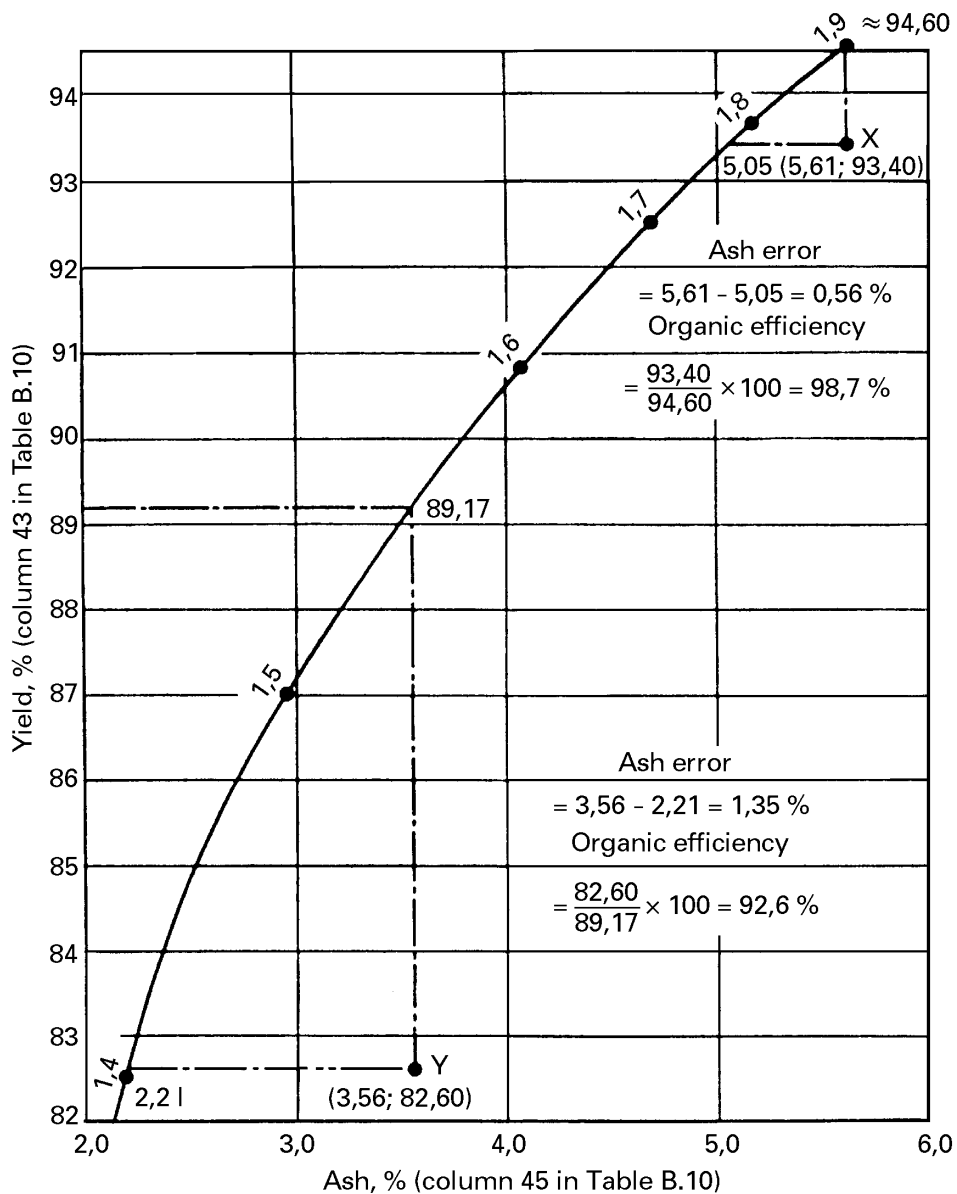
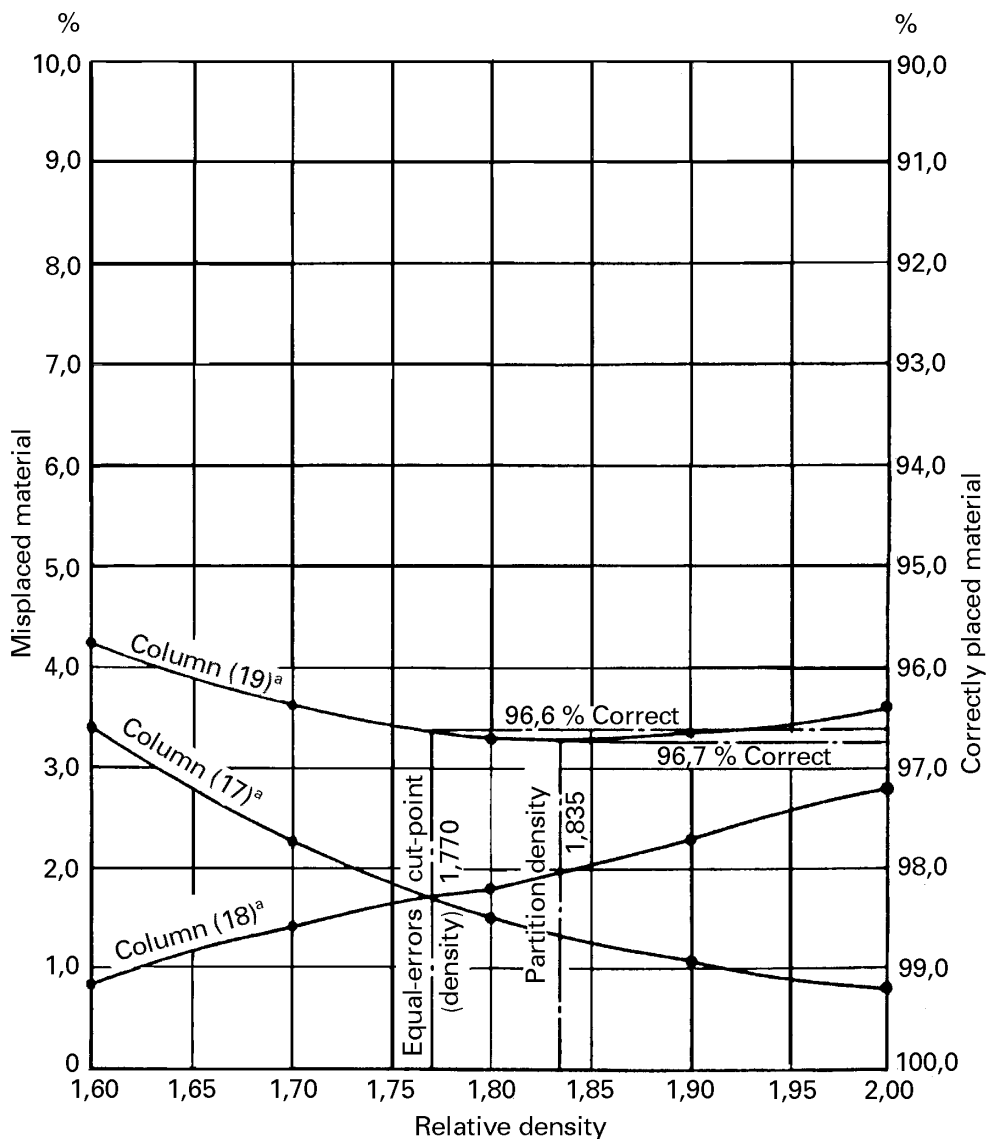
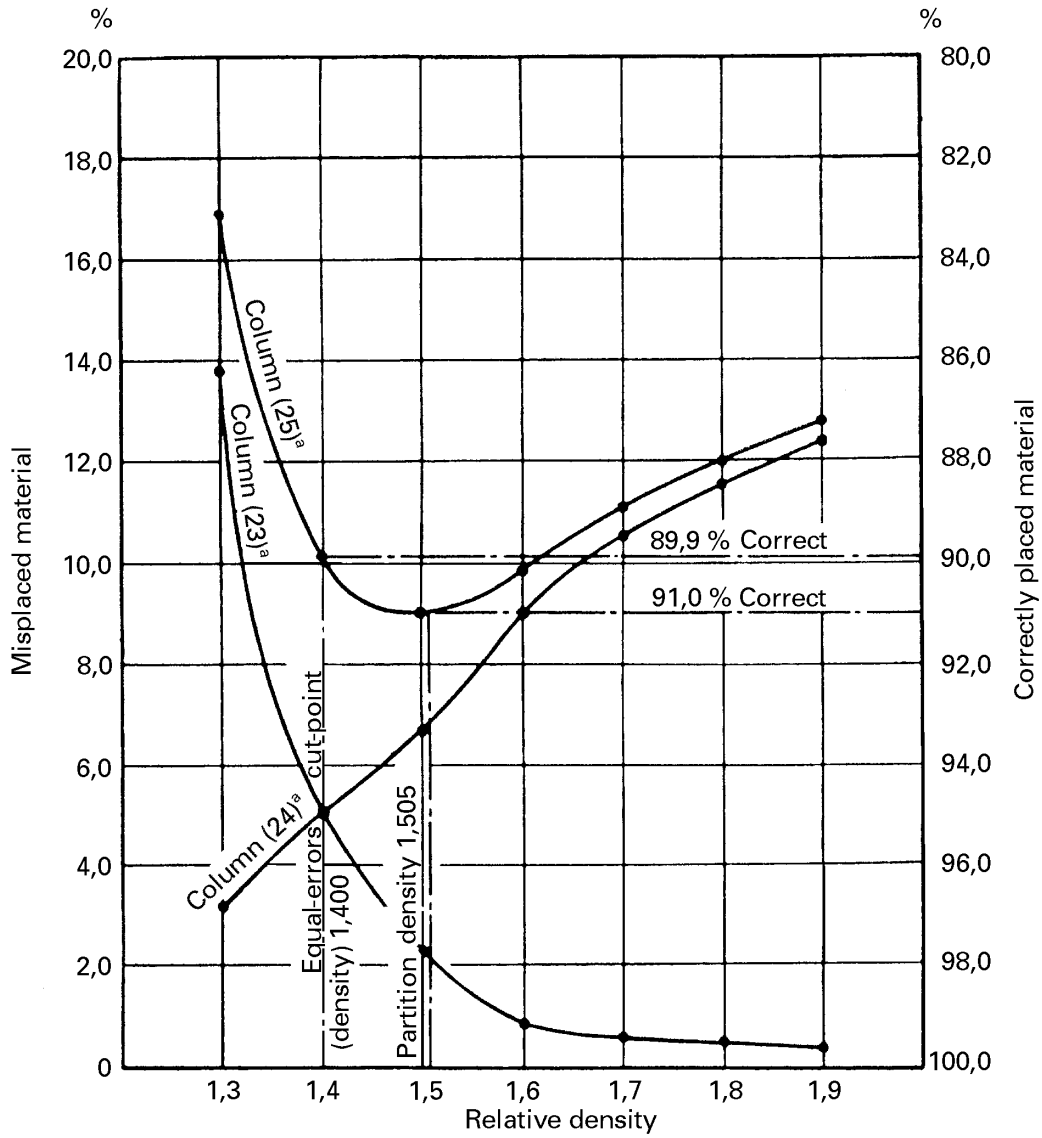

Figure C.2 — Ash error and organic efficiency (see B.3.3)



^a Column in Table B.8.

Figure C.3 — Correctly placed (and misplaced) material — High-density cut (see B.3.4)



a Column in Table B.8.

Figure C.4 — Correctly placed (and misplaced) material — Low-density cut (see B.3.5)

BSI — British Standards Institution

BSI is the independent national body responsible for preparing British Standards. It presents the UK view on standards in Europe and at the international level. It is incorporated by Royal Charter.

Revisions

British Standards are updated by amendment or revision. Users of British Standards should make sure that they possess the latest amendments or editions.

It is the constant aim of BSI to improve the quality of our products and services. We would be grateful if anyone finding an inaccuracy or ambiguity while using this British Standard would inform the Secretary of the technical committee responsible, the identity of which can be found on the inside front cover. Tel: 020 8996 9000. Fax: 020 8996 7400.

BSI offers members an individual updating service called PLUS which ensures that subscribers automatically receive the latest editions of standards.

Buying standards

Orders for all BSI, international and foreign standards publications should be addressed to Customer Services. Tel: 020 8996 9001. Fax: 020 8996 7001.

In response to orders for international standards, it is BSI policy to supply the BSI implementation of those that have been published as British Standards, unless otherwise requested.

Information on standards

BSI provides a wide range of information on national, European and international standards through its Library and its Technical Help to Exporters Service. Various BSI electronic information services are also available which give details on all its products and services. Contact the Information Centre. Tel: 020 8996 7111. Fax: 020 8996 7048.

Subscribing members of BSI are kept up to date with standards developments and receive substantial discounts on the purchase price of standards. For details of these and other benefits contact Membership Administration. Tel: 020 8996 7002. Fax: 020 8996 7001.

Copyright

Copyright subsists in all BSI publications. BSI also holds the copyright, in the UK, of the publications of the international standardization bodies. Except as permitted under the Copyright, Designs and Patents Act 1988 no extract may be reproduced, stored in a retrieval system or transmitted in any form or by any means – electronic, photocopying, recording or otherwise – without prior written permission from BSI.

This does not preclude the free use, in the course of implementing the standard, of necessary details such as symbols, and size, type or grade designations. If these details are to be used for any other purpose than implementation then the prior written permission of BSI must be obtained.

If permission is granted, the terms may include royalty payments or a licensing agreement. Details and advice can be obtained from the Copyright Manager. Tel: 020 8996 7070.