

BS ISO 812:2011



BSI Standards Publication

Rubber, vulcanized or thermoplastic — Determination of low-temperature brittleness

bsi.

...making excellence a habit.™

National foreword

This British Standard is the UK implementation of ISO 812:2011. It supersedes BS ISO 812:2006 which is withdrawn.

The UK participation in its preparation was entrusted to Technical Committee PRI/22, Physical testing of rubber.

A list of organizations represented on this committee can be obtained on request to its secretary.

This publication does not purport to include all the necessary provisions of a contract. Users are responsible for its correct application.

© BSI 2011

ISBN 978 0 580 69686 2

ICS 83.060

Compliance with a British Standard cannot confer immunity from legal obligations.

This British Standard was published under the authority of the Standards Policy and Strategy Committee on 30 November 2011.

Amendments issued since publication

Date	Text affected
------	---------------

INTERNATIONAL
STANDARD

BS ISO 812:2011

ISO
812

Third edition
2011-11-01

**Rubber, vulcanized or thermoplastic —
Determination of low-temperature
brittleness**

*Caoutchouc vulcanisé ou thermoplastique — Détermination de la
fragilité à basse température*



Reference number
ISO 812:2011(E)

© ISO 2011



COPYRIGHT PROTECTED DOCUMENT

© ISO 2011

All rights reserved. Unless otherwise specified, no part of this publication may be reproduced or utilized in any form or by any means, electronic or mechanical, including photocopying and microfilm, without permission in writing from either ISO at the address below or ISO's member body in the country of the requester.

ISO copyright office
Case postale 56 • CH-1211 Geneva 20
Tel. + 41 22 749 01 11
Fax + 41 22 749 09 47
E-mail copyright@iso.org
Web www.iso.org

Published in Switzerland

Contents

Page

Foreword	iv
1 Scope	1
2 Normative references	1
3 Terms and definitions	2
4 Apparatus and materials.....	2
5 Calibration	4
6 Test pieces	4
7 Time interval between manufacture and testing.....	4
8 Procedure	5
8.1 Procedure A (determination of brittleness temperature)	5
8.2 Procedure B (determination of 50 % brittleness temperature)	5
8.3 Procedure C (testing at a specified temperature)	6
9 Precision	7
10 Test report.....	7
Annex A (informative) Speed calibration of a solenoid-actuated low-temperature impact tester.....	8
Annex B (normative) Calibration schedule	11
Annex C (informative) Precision.....	13

Foreword

ISO (the International Organization for Standardization) is a worldwide federation of national standards bodies (ISO member bodies). The work of preparing International Standards is normally carried out through ISO technical committees. Each member body interested in a subject for which a technical committee has been established has the right to be represented on that committee. International organizations, governmental and non-governmental, in liaison with ISO, also take part in the work. ISO collaborates closely with the International Electrotechnical Commission (IEC) on all matters of electrotechnical standardization.

International Standards are drafted in accordance with the rules given in the ISO/IEC Directives, Part 2.

The main task of technical committees is to prepare International Standards. Draft International Standards adopted by the technical committees are circulated to the member bodies for voting. Publication as an International Standard requires approval by at least 75 % of the member bodies casting a vote.

Attention is drawn to the possibility that some of the elements of this document may be the subject of patent rights. ISO shall not be held responsible for identifying any or all such patent rights.

ISO 812 was prepared by Technical Committee ISO/TC 45, *Rubber and rubber products*, Subcommittee SC 2, *Testing and analysis*.

This third edition cancels and replaces the second edition (ISO 812:2006), which has been technically revised mainly to include an annex (Annex B) specifying a calibration schedule for the apparatus used.

Rubber, vulcanized or thermoplastic — Determination of low-temperature brittleness

WARNING — Persons using this International Standard should be familiar with normal laboratory practice. This standard does not purport to address all of the safety problems, if any, associated with its use. It is the responsibility of the user to establish appropriate safety and health practices and to ensure compliance with any national regulatory conditions.

IMPORTANT — Certain procedures specified in this International Standard might involve the use or generation of substances, or the generation of waste, that could constitute a local environmental hazard. Reference should be made to appropriate documentation on safe handling and disposal after use.

1 Scope

This International Standard specifies a method for determining the lowest temperature at which rubber materials do not exhibit brittle failure or the temperature at which half of the test pieces used in a test fail when impacted under specified conditions.

The temperatures thus determined do not necessarily relate to the lowest temperature at which the material can be used since the brittleness will be affected by the conditions of test and especially by the rate of impact. Data obtained by this method should, therefore, be used to predict the behaviour of rubbers at low temperatures only in applications in which the conditions of deformation are similar to those specified in the test.

Three procedures are described:

- procedure A, in which the brittleness temperature is determined;
- procedure B, in which the brittleness temperature for 50 % failure is determined;
- procedure C, in which the test piece is impacted at a specified temperature.

Procedure C is used in the classification of rubber materials and for specification purposes.

NOTE A similar test for rubber-coated fabrics is described in ISO 4646, *Rubber- or plastics-coated fabrics — Low-temperature impact test*.

2 Normative references

The following referenced documents are indispensable for the application of this document. For dated references, only the edition cited applies. For undated references, the latest edition of the referenced document (including any amendments) applies.

ISO 18899:2004, *Rubber — Guide to the calibration of test equipment*

ISO 23529, *Rubber — General procedures for preparing and conditioning test pieces for physical test methods*

3 Terms and definitions

For the purposes of this document, the following terms and definitions apply.

**3.1
brittleness temperature**
lowest temperature at which none of a set of test pieces fractures due to low-temperature embrittlement when tested under the specified conditions

**3.2
50 % brittleness temperature**
temperature at which 50 % of a set of test pieces fracture due to low-temperature embrittlement when tested under the specified conditions

**3.3
testing speed**
relative linear velocity at impact between the striking edge of the test apparatus and a clamped test piece

4 Apparatus and materials

4.1 Test piece clamp and striker, meeting the requirements of 4.1.1 to 4.1.3.

4.1.1 The test piece clamp shall be rigid and designed to hold the test piece(s) as cantilever beam(s). Each individual test piece shall be held firmly and securely in the clamp without distortion. A suitable example of a clamp is shown in Figure 1.

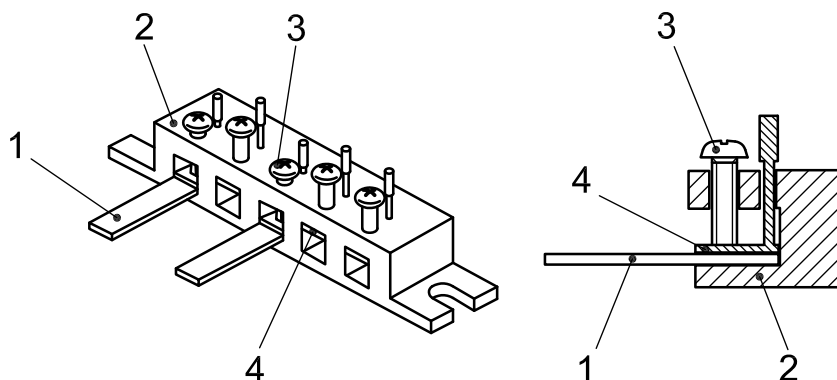

- Key**
- 1 test piece
 - 2 body of clamp
 - 3 holding screw
 - 4 test piece holder

Figure 1 — Example of test piece clamp

4.1.2 The striking edge shall move relative to the test piece(s) along a path normal to the upper surface of the test piece(s) at a linear testing speed of $2,0 \text{ m/s} \pm 0,2 \text{ m/s}$ at impact. The speed shall be maintained within this range for at least 6 mm of travel following the impact.

In order to obtain a speed within the specified limits during and after impact, care shall be taken to ensure that the striking energy is sufficient. It has been found that a striking energy of at least 3,0 J per test piece is necessary. It might, therefore, be necessary to limit the number of test pieces impacted at one time.

4.1.3 The principal dimensions of the apparatus [see Figures 2a) and 2b)] shall be as follows:

- a) the striking edge shall have a radius of $1,6 \text{ mm} \pm 0,1 \text{ mm}$;
- b) the clearance between the striker and the test piece clamp at impact shall be $6,4 \text{ mm} \pm 0,3 \text{ mm}$;
- c) the separation between the point of impact of the striking edge and the test piece clamp shall be $8 \text{ mm} \pm 0,3 \text{ mm}$;
- d) the clamping length of the test piece clamp shall be $6,8 \text{ mm} \pm 0,3 \text{ mm}$.

NOTE Commercial apparatus is available meeting the requirements of this International Standard in which the striking edge is rotated by a motor, or travels in a straight line under the action of a solenoid, gravity or a spring. A method for the speed calibration of a solenoid-actuated low-temperature impact tester is given in Annex A.

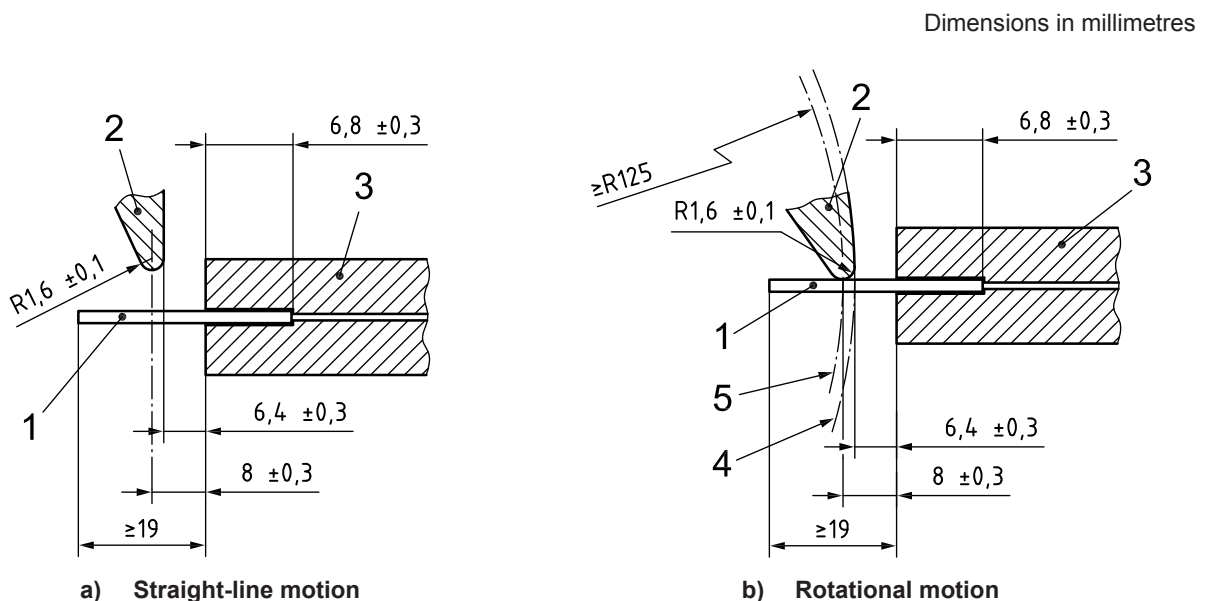

Key

- 1 test piece
- 2 striker
- 3 test piece clamp
- 4 locus described by point on striker closest to test piece clamp
- 5 locus described by impact point on striker

Figure 2 — Test piece clamp and striker

4.2 **Heat-transfer medium**, liquid or gaseous, which remains fluid at the test temperature and which does not appreciably affect the material being tested, as prescribed in ISO 23529.

Gases can be employed as the heat-transfer medium provided the design of the apparatus is such that results obtained using them will duplicate those obtained with liquids.

The following fluids have been used satisfactorily:

- a) for temperatures down to $-60 \text{ }^\circ\text{C}$, silicone fluids of kinematic viscosity of about $5 \text{ mm}^2/\text{s}$ at ambient temperature, which are usually suitable owing to their chemical inertness towards rubbers, their non-flammability and their non-toxicity;
- b) for temperatures down to $-73 \text{ }^\circ\text{C}$, ethanol;
- c) for temperatures down to $-120 \text{ }^\circ\text{C}$, methylcyclohexane cooled by liquid nitrogen (found to be satisfactory with the use of suitable apparatus).

4.3 Temperature-measuring device, capable of measuring the temperature to within 0,5 °C over the whole range of temperatures over which the apparatus is to be used.

The temperature sensor shall be positioned near the test pieces.

4.4 Temperature control, capable of maintaining the temperature of the heat-transfer medium to within ± 1 °C.

4.5 Container for the heat-transfer medium: A bath for a liquid medium or a test chamber for a gaseous medium, with means of heating the heat-transfer medium.

4.6 Means of agitating the heat-transfer medium: A stirrer for liquids, or a fan or blower for gases, which ensures thorough circulation of the heat-transfer medium. It is important that the stirrer also moves the liquid vertically to ensure a uniform temperature in the liquid.

4.7 Stopwatch or other timing device, calibrated in seconds.

5 Calibration

The test apparatus shall be calibrated in accordance with the schedule given in Annex B.

6 Test pieces

Test pieces shall be

- either type A: a strip 26 mm to 40 mm long, 6 mm \pm 1 mm wide and 2,0 mm \pm 0,2 mm thick;
- or type B: a test piece 2,0 mm \pm 0,2 mm thick and of the shape and dimensions given in Figure 3.

Test pieces shall be prepared in accordance with ISO 23529. They shall normally be punched from sheet using a suitable sharp die. Alternatively, type A test pieces can be prepared using sharp, parallel double-bladed cutters, in a single stroke. The strip so formed is then cut to the correct length.

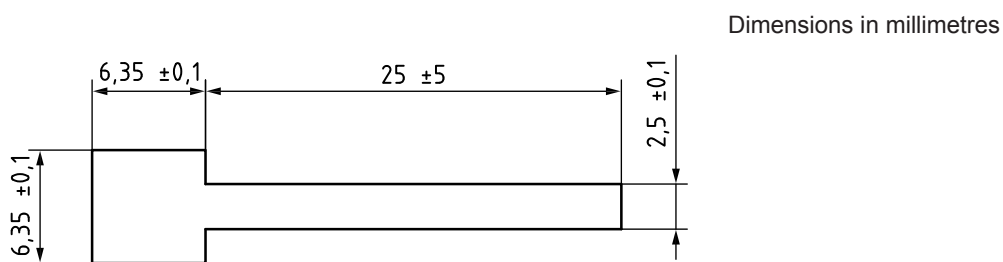

Figure 3 — Type B test piece

7 Time interval between manufacture and testing

Unless otherwise specified, the time interval between the date the material was formed and testing shall be in accordance with ISO 23529.

8 Procedure

8.1 Procedure A (determination of brittleness temperature)

8.1.1 Bring the bath or test chamber to a temperature below the expected lowest temperature of non-failure. In the case of a liquid heat-transfer medium, place sufficient liquid in the bath to ensure approximately 25 mm depth or more of the liquid over the test piece(s). Pre-cool the test piece clamp by immersing it in the cooled bath or test chamber.

8.1.2 Quickly mount the test piece(s) in the test piece clamp and immerse them for 5 min at the test temperature when using a liquid medium or for 10 min when using a gaseous medium (see also ISO 23529).

NOTE 1 For very soft materials, it might be necessary to use a device to support the test piece horizontally until just before the striker is released.

The free length of the test piece(s) shall be greater than 19 mm.

Test five type A or type B test pieces. If the available striking energy has the minimum value specified in 4.1.2, they may all be tested at the same time.

Proper tightening of the clamp is of the utmost importance. The clamp shall be tightened so that each test piece is held with approximately the same clamping torque.

NOTE 2 It has been reported that the temperature at which a test piece fails might be affected by the clamping torque. Clamping to a torque of 0,15 N·m to 0,25 N·m is suggested.

8.1.3 After immersion for the specified time at the test temperature, record the temperature and deliver a single impact blow to the test piece(s).

8.1.4 Remove the test pieces from the test piece clamp and allow them to reach standard laboratory temperature. Examine each test piece to determine whether or not it has failed. Failure is defined as any crack, fissure or hole visible to the naked eye, or complete separation into two or more pieces. Where a test piece has not completely separated, bend it to an angle of 90° in the same direction as the bend caused by the impact. Then examine it for cracks at the bend.

8.1.5 Repeat the test at each of a series of successively higher temperatures 10 °C apart, using a new set of test pieces at each temperature, until no failure is obtained. Then decrease the temperature to the highest value at which a failure was observed and carry out tests at temperatures increasing at 2 °C intervals to determine the temperature at which no failure is observed. Record this as the brittleness temperature.

If crystallization or time-dependent effects of plasticizers are to be studied, longer conditioning periods in a gaseous medium may be used.

8.2 Procedure B (determination of 50 % brittleness temperature)

8.2.1 Carry out the procedure described in 8.1.1 to 8.1.4, except that the starting temperature is that at which 50 % failure is expected.

8.2.2 If all of the test pieces fail at the starting temperature, increase the temperature by 10 °C and repeat the test. If none of the test pieces fail at the starting temperature, decrease the temperature by 10 °C and repeat the test. Increase or decrease the temperature in increments of 2 °C and repeat the test until the lowest temperature at which none of the test pieces fails and the highest temperature at which all of the test pieces fail is determined. Record the number of failures at each temperature. Use a new set of test pieces at each temperature. Determine the 50 % brittleness temperature by calculation using the equation in 8.2.3 or by the graphical method described in 8.2.4.

8.2.3 Calculation: From the number of failures at each temperature, calculate the percentage of failures at each temperature to determine the 50 % brittleness temperature from the following equation:

$$T_b = T_h + \Delta T \left(\frac{S}{100} - \frac{1}{2} \right)$$

where

T_b is the 50 % brittleness temperature (°C);

T_h is the highest temperature at which all test pieces fail (°C);

ΔT is the interval between the test temperatures (°C);

S is the total of the percentages of failures at each temperature, from the temperature at which no test piece fails to the temperature at which they all fail, T_h (%).

8.2.4 Graphical method: From the number of failures at each temperature, calculate the percentage of failures at each temperature. Next, using normal probability paper as shown in Figure 4, plot these percentages against the temperature, taking the temperature on the linear scale and the percentage of failures on the probability scale, and draw the best-fit straight line through the points. The temperature at the point of intersection of this line and the 50 % probability line is T_b , the 50 % brittleness temperature.

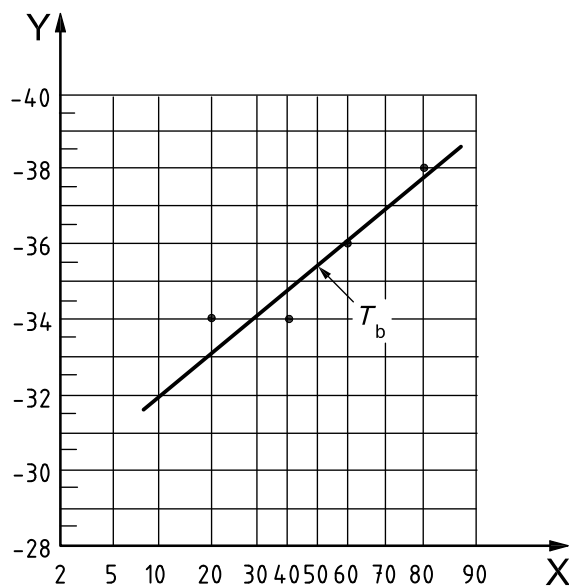

Key

X percentage of failures (%)

Y temperature (°C)

Figure 4 — Determination of 50 % brittleness temperature, T_b , by the graphical method

8.3 Procedure C (testing at a specified temperature)

8.3.1 Carry out the procedure described in 8.1.1 to 8.1.4, except that the temperature used is that specified in the material specification or material classification.

8.3.2 Report the material as satisfactory if no failure is observed in any one of the test pieces, or unsatisfactory if any test pieces have failed.

9 Precision

See Annex C.

10 Test report

The test report shall include the following information:

- a) sample details:
 - 1) a full description of the sample and its origin,
 - 2) the method of preparation of the test pieces from the sample, for example moulded or cut;
- b) test method:
 - 1) a reference to the test method used, i.e. the number of this International Standard,
 - 2) whether procedure A, B or C was used,
 - 3) the type of test piece used;
- c) test details:
 - 1) the heat-transfer medium and type of test equipment used,
 - 2) the laboratory temperature,
 - 3) the time and temperature of conditioning prior to test,
 - 4) the temperature(s) of test,
 - 5) details of any procedures not specified in this International Standard;
- d) test results:
 - 1) the number of test pieces used, and the number impacted at each impact,
 - 2) in the case of procedure A or B, the brittleness temperature or 50 % brittleness temperature, respectively,
 - 3) in the case of procedure C, whether or not the material was satisfactory;
- e) the date of the test.

Annex A (informative)

Speed calibration of a solenoid-actuated low-temperature impact tester¹⁾

A.1 Speed calibration prior to testing

A.1.1 Principle

The height, h , to which a steel ball, suspended on the striker mechanism of the tester, rises after the striker has had its upward motion halted by contact with a mechanical stop is measured. The ball decelerates in such a manner that the law governing a body moving freely under the influence of gravity applies.

A.1.2 Procedure

A.1.2.1 Securing ball support

Remove either one of the nuts that fasten the striking bar guide rods to the solenoid armature yoke. Place the small hole in the ball support (see Figure A.1) over the guide rod and replace and secure the nut.

Dimensions in millimetres

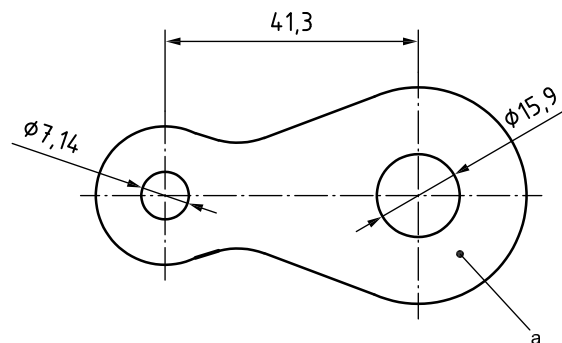

^a Thickness = 3,2 mm.

Figure A.1 — Ball support

A.1.2.2 Adjusting stroke or striker

Remove the metal guard from around the solenoid. Spread open the rubber bumper (see Figure A.2) and insert it around the armature. Replace the solenoid guard. Insert a typical test piece into the specimen holder of the tester. Raise the striking mechanism by hand until the end of the stroke is reached. It is essential that, with the striking mechanism raised to its maximum height, the striker bar of the tester is in contact with the test piece but that the bar is not in the plane of the test piece. If the striker bar is not in contact with the test piece, the rubber bumper should be removed and replaced by a thinner bumper. Conversely, if the striker bar moves into the plane of the test piece, the bumper should be replaced by a thicker one.

1) This annex applies only to certain types of impact-testing apparatus.

Dimensions in millimetres

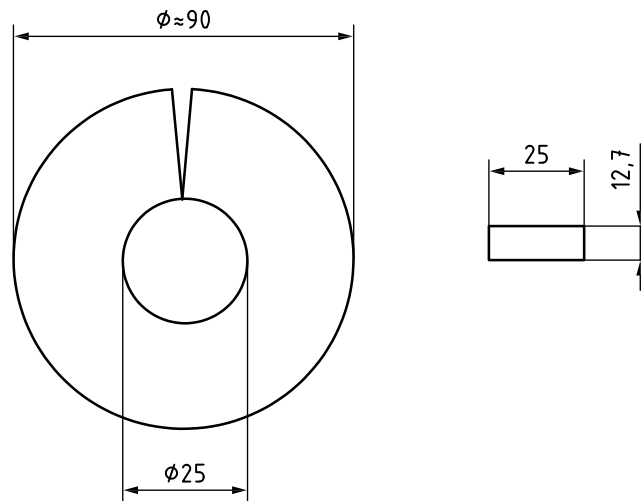

Hardness of bumper \approx 70 IRHD

Figure A.2 — Rubber bumper

A.1.2.3 Placement of ball and measuring tube

Place a 19 mm diameter steel ball on the ball holder. Clamp a glass or clear-plastic tube with a minimum inside diameter of 25,4 mm in a vertical position directly over the ball. The tube should contain a scale divided into 5 mm intervals. The zero position on the scale should be aligned with the top of the ball when the ball is at the top of the stroke of the striker mechanism.

NOTE In theory, the upward flight of the ball is independent of the mass of the ball. However, if the mass is too large, the motion of the striker bar might be impeded.

A.1.2.4 Measurement and calculation

With the tester equipped as described above and devoid of test pieces and immersion medium, actuate the solenoid and read the ball height to the nearest 5 mm. Make at least five measurements. Average all results and convert the average to metres. Determine the striker speed, v , in metres per second, from the following equation:

$$v = \sqrt{2gh}$$

where

g is the acceleration due to gravity, in metres per second squared ($= 9,8 \text{ m/s}^2$);

h is the average ball height, in metres.

Calibration measurements should be made with the tester supported on a non-resilient surface, such as a laboratory bench or concrete floor. Resilient mountings tend to absorb some of the striker energy, causing low ball height values.

A.2 Speed calibration during testing

A.2.1 With the tester equipped with ball support, ball and measuring tube (see Clause A.1), but without the rubber bumper (tested in normal operating condition) and devoid of test pieces and immersion medium, actuate the solenoid and read the ball height to the nearest 5 mm. Make ten measurements. From the lowest and highest ball height readings, determine the range in striker speed, using the equation in A.1.2.4. This range is termed “range of speed at the top of the stroke”.

A.2.2 With the tester equipped as described in A.2.1, but also with test piece(s) and immersion medium, conduct the brittleness test as described in Clause 8. Read the ball height each time the solenoid is actuated. Convert the ball height to speed as shown in A.1.2.4. If the speed lies within the predetermined range of speeds at the top of the stroke, the test should be considered valid. If the speed lies outside the predetermined range, the test is invalid and the result should not be reported. Should successive tests be invalid, adjustments should be made to bring the speed at the top of the stroke within the acceptable, predetermined range. This may be accomplished by reducing the number of test pieces tested per impact.

A.2.3 The following example typifies the entire speed calibration procedure for solenoid-actuated testers.

- a) Using the procedure specified in Clause A.1, the striker speed at the point of impact of a tester devoid of test pieces and immersion medium was found to be 1,9 m/s. This speed is within the limits specified in 4.1.2.
- b) Using the procedure in A.2.1, with the tester devoid of test pieces and immersion medium, the range of striker speeds at the top of the stroke was found to be 2,5 m/s to 2,7 m/s. This range becomes the acceptable range for this series of tests. The acceptable range should be established each time the striker speed at the point of impact is determined (see Clause A.1).
- c) Using the procedure in A.2.2, with the tester containing test piece(s) and immersion medium, the speed at the top of the stroke during the first solenoid actuation was found to be 2,5 m/s. The speed is within the acceptable range and the test is valid.
- d) The speeds at the top of the stroke during the second and third solenoid actuations were found to be 2,4 m/s and 2,3 m/s, respectively. These speeds are outside the acceptable range and both tests are invalid.
- e) Adjustments were made to increase the speed at the top of the stroke, using the procedure given in A.2.2.
- f) The speeds at the top of the stroke during the fourth and all subsequent solenoid actuations were found to lie between 2,5 m/s and 2,7 m/s. The results of all these tests are valid.

Annex B (normative)

Calibration schedule

B.1 Inspection

Before any calibration is undertaken, the condition of the items to be calibrated shall be ascertained by inspection and recorded in any calibration report or certificate. It shall be reported whether calibration is made in the “as-received” condition or after rectification of any abnormality or fault.

It shall be ascertained that the apparatus is generally fit for the intended purpose, including any parameters specified as approximate and for which the apparatus does not therefore need to be formally calibrated. If such parameters are liable to change, then the need for periodic checks shall be written into the detailed calibration procedures.

B.2 Schedule

Verification/calibration of the test apparatus is a mandatory part of this International Standard. However, the frequency of calibration and the procedures used are, unless otherwise stated, at the discretion of the individual laboratory, using ISO 18899 for guidance.

The calibration schedule given in Table B.1 has been compiled by listing all of the parameters specified in the test method, together with the specified requirement. A parameter and requirement can relate to the main test apparatus, to part of that apparatus or to an ancillary apparatus necessary for the test.

For each parameter, a calibration procedure is indicated by reference to ISO 18899, to another publication or to a procedure particular to the test method which is detailed (whenever a calibration procedure which is more specific or detailed than that in ISO 18899 is available, it shall be used in preference).

The verification frequency for each parameter is given by a code-letter. The code-letters used in the calibration schedule are:

- C requirement to be confirmed, but no measurement;
- N initial verification only;
- S standard interval as given in ISO 18899;
- U in use.

Table B.1 — Calibration frequency schedule

Parameter	Requirement	Clause or subclause in ISO 18899:2004	Verification frequency guide	Notes
Test piece clamp	Holds test piece as a cantilever firmly and securely without distortion	C	U	See Figure 1
Path of striking edge at impact	Normal to upper surface of test piece	C	N	—
Linear speed of striking edge	2,0 m/s \pm 0,2 m/s at impact and for \geq 6 mm after impact	23.4	S	—
Striking energy	\geq 3,0 J per test piece	21.5	N	—
Striking-edge radius	1,6 mm \pm 0,1 mm	15.3	S	See Figure 2
Clearance between striker and clamp at impact	6,4 mm \pm 0,3 mm	15.2	S	See Figure 2
Separation between striking edge and clamp at impact	8,0 mm \pm 0,3 mm	15.2	S	See Figure 2
Temperature-measuring device	Accurate to within \pm 0,5 °C and as near as possible to the test pieces	18	S	—
Temperature control	Accurate to within \pm 1 °C	C	U	As shown by temperature-measuring device
Container for heat-transfer medium	Equipped with a means of agitation	C	N	—
Heat-transfer medium	Which does not effect the rubber and is as prescribed in ISO 23529	—	—	Suitable liquids listed in 4.2

In addition to the items listed in Table B.1, use of the following is implied, all of which need calibrating in accordance with ISO 18899:

- a timer;
- instruments for determining the dimensions of the test pieces.

Annex C (informative)

Precision

C.1 General

Precision calculations to express repeatability and reproducibility were performed in accordance with ISO/TR 9272:2005, *Rubber and rubber products — Determination of precision for test method standards*. Outliers in the original data were treated at the 5 % and 2 % significance level in accordance with the procedures described in ISO/TR 9272.

C.2 Interlaboratory test programme

C.2.1 An interlaboratory test programme (ITP) was organized by Japan in 2004. Three different compounds of SBR, CR and NBR were used for the brittleness testing. These compounds have different brittleness temperatures.

A total of seven laboratories participated in the ITP, four from Japan and one each from Germany, Thailand and the United Kingdom.

Fully prepared rubber test pieces were sent to each laboratory for evaluation in the ITP, i.e. a type 1 precision was determined.

C.2.2 The brittleness temperature and the 50 % brittleness temperature were determined by the procedures described in Clause 8.

C.2.3 Two types of test piece, type A (strip type) and type B (T-shaped type), were used.

C.3 Precision results

The results of the ITP are given in Table C.1. The symbols used in the table are defined as follows:

- r is the repeatability, in measurement units;
- (r) is the repeatability, in percent (relative);
- R is the reproducibility, in measurement units;
- (R) is the reproducibility, in percent (relative).

Table C.1 — Precision data

Test piece	Test measurement	Material	Mean value (number of results = $7 \times 2 = 14$)	Within-laboratory (repeatability)		Between laboratories (reproducibility)	
				<i>r</i>	(<i>r</i>)	<i>R</i>	(<i>R</i>)
Type A	Brittleness temperature (°C)	SBR	-50,60	0,00	0,00	5,52	-10,90
		CR	-32,34	2,17	-6,71	7,78	-24,07
		NBR	-26,00	5,17	-19,87	7,42	-28,52
	50 % brittleness temperature (°C)	SBR	-53,64	1,64	-3,06	5,11	-9,52
		CR	-33,93	1,32	-3,89	5,39	-15,89
		NBR	-28,64	2,12	-7,39	10,31	-35,99
Type B	Brittleness temperature (°C)	SBR	-51,30	2,83	-5,52	12,96	-25,26
		CR	-33,32	2,74	-8,22	7,98	-23,95
		NBR	-26,80	4,38	-16,36	9,34	-34,86
	50 % brittleness temperature (°C)	SBR	-55,02	2,70	-4,91	13,73	-24,96
		CR	-35,63	1,83	-5,15	1,90	-5,34
		NBR	-30,15	3,53	-11,69	11,58	-38,40

The repeatability of the brittleness temperature of SBR is given as 0 because all the within-laboratory results had the same value after the elimination of outliers.

In terms of the mean values, the 50 % brittleness temperature was, as would be expected, lower than the brittleness temperature. The type B test pieces gave slightly lower temperatures than the type A test pieces.

In terms of the precision obtained, the values obtained for the 50 % brittleness temperature and the brittleness temperature for both type A and type B test pieces were, on average, very similar.

British Standards Institution (BSI)

BSI is the national body responsible for preparing British Standards and other standards-related publications, information and services.

BSI is incorporated by Royal Charter. British Standards and other standardization products are published by BSI Standards Limited.

About us

We bring together business, industry, government, consumers, innovators and others to shape their combined experience and expertise into standards-based solutions.

The knowledge embodied in our standards has been carefully assembled in a dependable format and refined through our open consultation process. Organizations of all sizes and across all sectors choose standards to help them achieve their goals.

Information on standards

We can provide you with the knowledge that your organization needs to succeed. Find out more about British Standards by visiting our website at bsigroup.com/standards or contacting our Customer Services team or Knowledge Centre.

Buying standards

You can buy and download PDF versions of BSI publications, including British and adopted European and international standards, through our website at bsigroup.com/shop, where hard copies can also be purchased.

If you need international and foreign standards from other Standards Development Organizations, hard copies can be ordered from our Customer Services team.

Subscriptions

Our range of subscription services are designed to make using standards easier for you. For further information on our subscription products go to bsigroup.com/subscriptions.

With **British Standards Online (BSOL)** you'll have instant access to over 55,000 British and adopted European and international standards from your desktop. It's available 24/7 and is refreshed daily so you'll always be up to date.

You can keep in touch with standards developments and receive substantial discounts on the purchase price of standards, both in single copy and subscription format, by becoming a **BSI Subscribing Member**.

PLUS is an updating service exclusive to BSI Subscribing Members. You will automatically receive the latest hard copy of your standards when they're revised or replaced.

To find out more about becoming a BSI Subscribing Member and the benefits of membership, please visit bsigroup.com/shop.

With a **Multi-User Network Licence (MUNL)** you are able to host standards publications on your intranet. Licences can cover as few or as many users as you wish. With updates supplied as soon as they're available, you can be sure your documentation is current. For further information, email bsmusales@bsigroup.com.

BSI Group Headquarters

389 Chiswick High Road London W4 4AL UK

Revisions

Our British Standards and other publications are updated by amendment or revision.

We continually improve the quality of our products and services to benefit your business. If you find an inaccuracy or ambiguity within a British Standard or other BSI publication please inform the Knowledge Centre.

Copyright

All the data, software and documentation set out in all British Standards and other BSI publications are the property of and copyrighted by BSI, or some person or entity that owns copyright in the information used (such as the international standardization bodies) and has formally licensed such information to BSI for commercial publication and use. Except as permitted under the Copyright, Designs and Patents Act 1988 no extract may be reproduced, stored in a retrieval system or transmitted in any form or by any means – electronic, photocopying, recording or otherwise – without prior written permission from BSI. Details and advice can be obtained from the Copyright & Licensing Department.

Useful Contacts:

Customer Services

Tel: +44 845 086 9001

Email (orders): orders@bsigroup.com

Email (enquiries): cservices@bsigroup.com

Subscriptions

Tel: +44 845 086 9001

Email: subscriptions@bsigroup.com

Knowledge Centre

Tel: +44 20 8996 7004

Email: knowledgecentre@bsigroup.com

Copyright & Licensing

Tel: +44 20 8996 7070

Email: copyright@bsigroup.com



...making excellence a habit.™