

# Fruit and vegetable products — Determination of mineral impurities content

ICS 67.080.01

## National foreword

This British Standard reproduces verbatim ISO 762:2003 and implements it as the UK national standard.

There has been no UK participation in its preparation of this document. Any enquires on the text should be sent to Head of Standards — International Content.

### Cross-references

The British Standards which implement international publications referred to in this document may be found in the *BSI Catalogue* under the section entitled “International Standards Correspondence Index”, or by using the “Search” facility of the *BSI Electronic Catalogue* or of British Standards Online.

This publication does not purport to include all the necessary provisions of a contract. Users are responsible for its correct application.

**Compliance with a British Standard does not of itself confer immunity from legal obligations.**

### Summary of pages

This document comprises a front cover, an inside front cover, the ISO title page, pages ii and iii, a blank page, pages 1 to 5 and a back cover.

The BSI copyright notice displayed in this document indicates when the document was last issued.

### Amendments issued since publication

Amd. No.	Date	Comments

This British Standard was published under the authority of the Standards Policy and Strategy Committee on 25 November 2003

© BSI 25 November 2003

ISBN 0 580 42972 5

# INTERNATIONAL STANDARD

# ISO 762

Second edition  
2003-11-15

---

---

## **Fruit and vegetable products — Determination of mineral impurities content**

*Produits dérivés des fruits et légumes — Détermination de la teneur en  
impuretés minérales d'origine terrestre*



Reference number  
ISO 762:2003(E)



## Foreword

ISO (the International Organization for Standardization) is a worldwide federation of national standards bodies (ISO member bodies). The work of preparing International Standards is normally carried out through ISO technical committees. Each member body interested in a subject for which a technical committee has been established has the right to be represented on that committee. International organizations, governmental and non-governmental, in liaison with ISO, also take part in the work. ISO collaborates closely with the International Electrotechnical Commission (IEC) on all matters of electrotechnical standardization.

International Standards are drafted in accordance with the rules given in the ISO/IEC Directives, Part 2.

The main task of technical committees is to prepare International Standards. Draft International Standards adopted by the technical committees are circulated to the member bodies for voting. Publication as an International Standard requires approval by at least 75 % of the member bodies casting a vote.

Attention is drawn to the possibility that some of the elements of this document may be the subject of patent rights. ISO shall not be held responsible for identifying any or all such patent rights.

ISO 762 was prepared by Technical Committee ISO/TC 34, *Food products*, Subcommittee SC 3, *Fruit and vegetable products*.

This second edition cancels and replaces the first edition (ISO 762:1982), which has been technically revised.



# Fruit and vegetable products — Determination of mineral impurities content

## 1 Scope

This international Standard specifies a method for the determination of the mineral impurities content (impurities generally originating from the soil) of fruit and vegetable products.

## 2 Principle

Organic matter is separated by flotation and heavy impurities are separated by sedimentation. The sediment is incinerated at approximately 525 °C, and the residue obtained is weighed.

## 3 Apparatus

Usual laboratory equipment and, in particular, the following.

- 3.1 **Blender.**
- 3.2 **Beakers**, of capacities 1 000 ml.
- 3.3 **Filter paper**, Whatman No. 41<sup>1)</sup> or equivalent.
- 3.4 **Incineration dishes**, made of quartz, porcelain or platinum.
- 3.5 **Muffle furnace**, capable of being maintained at 525 °C ± 25 °C.
- 3.6 **Desiccator**, provided with an efficient desiccant.
- 3.7 **Analytical balance**, capable of weighing to the nearest 0,000 2 g.
- 3.8 **Heater**, gas or electric.
- 3.9 **Sieve**, of pore size ca. 1 mm to 2 mm.
- 3.10 **Stirring rod.**
- 3.11 **Washing equipment**, for washing out the impurities (see Figure 1).

---

1) Whatman No. 41 is an example of a suitable product available commercially. This information is given for the convenience of users of this International Standard and does not constitute an endorsement by ISO of this product.

## 4 Preparation of test sample

### 4.1 General case

Before taking the test portion, thoroughly mix the entire laboratory sample using, if necessary, the blender (3.1). Allow frozen or deep frozen products to thaw in a closed vessel and add the liquid formed during this process to the product before mixing.

### 4.2 Dried products

Mix the laboratory sample well. Weigh  $20 \text{ g} \pm 0,1 \text{ g}$  of the product, transfer it to a beaker (3.2) and add 400 ml of filtered tap water. Bring to the boil, then leave overnight at room temperature to allow the product to rehydrate.

## 5 Procedure

### 5.1 Test portion

#### 5.1.1 General case

Rapidly weigh  $100 \text{ g} \pm 1 \text{ g}$  of the test sample (4.1) into a beaker (3.2). If the mass of this sample is less than 100 g, weigh all of it.

#### 5.1.2 Dried products

Use all of the product taken in 4.2 as the test portion.

### 5.2 Determination

#### 5.2.1 Separation of sediments

Add filtered tap water to the beaker containing the test portion (4.1 or 4.2) until the beaker is almost completely full. Mix by agitating, if necessary using a stirring rod (3.10).

Allow the suspension to stand for 5 min, then put the beaker under the water tube as shown in Figure 1.

The important part of the washing equipment (3.11) is the water tank equipped with a leak tube for equalizing the pressure. In the tank, the water level shall be constant and 13 cm high; the overflow leaves the tank through the leak tube. One or more glass tubes, with 0,4 cm internal diameter, are connected to the bottom of the tank by rubber tubes. Their end parts are extruded. The distance between the bottom of the tank and the top end of the glass tube shall be 55 cm, the extruded part shall be 1 cm long and its internal diameter shall be 0,2 cm. The opening and closing of the stream is controlled by a clamp. Keeping these conditions, the flow rate through one glass tube shall be 200 ml/min. Put a glass tube filled loosely with cotton- or glass-wool between the tap and the tank to retain floating impurities.

Immerse the glass tube in the beaker containing the suspension in such position that the tip of it is 6 cm from the bottom of the beaker. Open the stream and continue the washing for 35 min to 40 min. During this time the fine fragments of plant fibre are washed out, while the sand, other mineral impurities and the larger fragments of seeds and skins settle, and the water becomes colourless and transparent in the beaker.

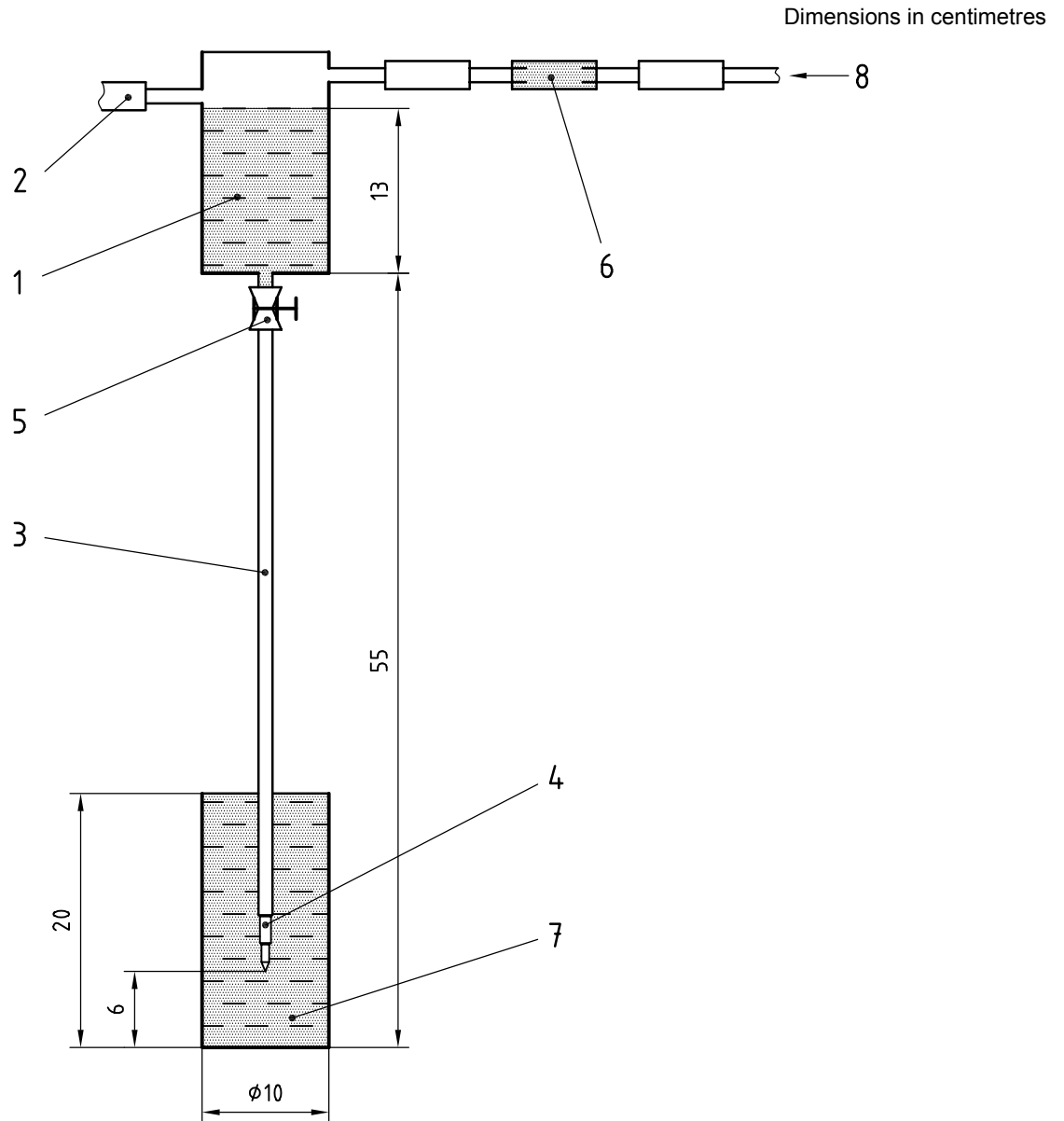

**Key**

- 1 water tank
- 2 leak tube
- 3 glass tube
- 4 end part of glass tube
- 5 clamp
- 6 cotton- or glass-wool
- 7 beaker containing the suspension
- 8 water

**Figure 1 — Washing equipment**

**5.2.2 Determination**

If, after the washing-out procedure (5.2.1), there are no visible fragments of plant but only the sand on the bottom of the beaker, remove the glass tube from the beaker. Wait for 3 min then decant carefully most of the water, avoiding any agitation of the settled fragments. Quantitatively filter the residue through a filter paper (3.3).

If, after the washing-out procedure (5.2.1), there remains a lot of plant fibres and larger fragments of seeds and plant skins on the bottom of the beaker, decant most of the water. Transfer the residue to a sieve (3.9) which is placed on a porcelain dish having an appropriate size. Wash the sand into the dish with water. Pour the water in 100 ml portions to separate the sand from the fragments of skin, seed and fibre. About 1 000 ml water are needed for this purpose.

**5.2.3 Preparation of the dish**

Heat the empty incineration dish (3.4) in the muffle furnace (3.5) set at 525 °C. Allow it to cool in the desiccator (3.6) and weigh to the nearest 0,000 2 g. Repeat until a constant mass is achieved.

**5.2.4 Incineration**

Transfer the filter paper and residue to the prepared incineration dish (5.2.3).

Heat the incineration dish for a few minutes using the heater (3.8), then transfer it to the muffle furnace (3.5) set at 525 °C. Incinerate it for 1 h. Cool in the desiccator (3.6) and weigh to the nearest 0,000 2 g. Repeat until a constant mass is achieved.

**5.2.5 Number of determinations**

Carry out at least two determinations of the same sample.

**6 Expression of results****6.1 Calculation**

The mineral impurities content, expressed as a percentage by mass, is given by the formula

$$(m_2 - m_1) \times \frac{100}{m_0} \%$$

where

$m_0$  is the mass, in grams, of the test portion (5.1);

$m_1$  is the mass, in grams, of the empty dish (5.2.3);

$m_2$  is the mass, in grams, of the dish and incinerated residue (5.2.4).

Take as the result the arithmetic mean of the values obtained in two determinations, provided that the requirement for repeatability (6.2) is satisfied.

Report the result to two decimal places.

## 6.2 Repeatability

The absolute difference between two independent single test results, obtained using the same method on identical test material in the same laboratory by the same operator using the same equipment within a short interval of time, will in not more than 5 % of cases be greater than 3 % of the mean value.

## 7 Test report

The test report shall specify:

- a) all information necessary for the complete identification of the sample;
- b) the sampling method used, if known;
- c) the test method used, with reference to this International Standard;
- d) all operating details not specified in this International Standard, or regarded as optional, together with details of any incidents which may have influenced the test result(s);
- e) the test result(s) obtained or, if the repeatability has been checked, the final quoted result obtained.

---

---

# BSI — British Standards Institution

BSI is the independent national body responsible for preparing British Standards. It presents the UK view on standards in Europe and at the international level. It is incorporated by Royal Charter.

## Revisions

British Standards are updated by amendment or revision. Users of British Standards should make sure that they possess the latest amendments or editions.

It is the constant aim of BSI to improve the quality of our products and services. We would be grateful if anyone finding an inaccuracy or ambiguity while using this British Standard would inform the Secretary of the technical committee responsible, the identity of which can be found on the inside front cover.  
Tel: +44 (0)20 8996 9000. Fax: +44 (0)20 8996 7400.

BSI offers members an individual updating service called PLUS which ensures that subscribers automatically receive the latest editions of standards.

## Buying standards

Orders for all BSI, international and foreign standards publications should be addressed to Customer Services. Tel: +44 (0)20 8996 9001.  
Fax: +44 (0)20 8996 7001. Email: [orders@bsi-global.com](mailto:orders@bsi-global.com). Standards are also available from the BSI website at <http://www.bsi-global.com>.

In response to orders for international standards, it is BSI policy to supply the BSI implementation of those that have been published as British Standards, unless otherwise requested.

## Information on standards

BSI provides a wide range of information on national, European and international standards through its Library and its Technical Help to Exporters Service. Various BSI electronic information services are also available which give details on all its products and services. Contact the Information Centre.  
Tel: +44 (0)20 8996 7111. Fax: +44 (0)20 8996 7048. Email: [info@bsi-global.com](mailto:info@bsi-global.com).

Subscribing members of BSI are kept up to date with standards developments and receive substantial discounts on the purchase price of standards. For details of these and other benefits contact Membership Administration.  
Tel: +44 (0)20 8996 7002. Fax: +44 (0)20 8996 7001.  
Email: [membership@bsi-global.com](mailto:membership@bsi-global.com).

Information regarding online access to British Standards via British Standards Online can be found at <http://www.bsi-global.com/bsonline>.

Further information about BSI is available on the BSI website at <http://www.bsi-global.com>.

## Copyright

Copyright subsists in all BSI publications. BSI also holds the copyright, in the UK, of the publications of the international standardization bodies. Except as permitted under the Copyright, Designs and Patents Act 1988 no extract may be reproduced, stored in a retrieval system or transmitted in any form or by any means – electronic, photocopying, recording or otherwise – without prior written permission from BSI.

This does not preclude the free use, in the course of implementing the standard, of necessary details such as symbols, and size, type or grade designations. If these details are to be used for any other purpose than implementation then the prior written permission of BSI must be obtained.

Details and advice can be obtained from the Copyright & Licensing Manager.  
Tel: +44 (0)20 8996 7070. Fax: +44 (0)20 8996 7553.  
Email: [copyright@bsi-global.com](mailto:copyright@bsi-global.com).