

BS ISO 606:2015



BSI Standards Publication

Short-pitch transmission precision roller and bush chains, attachments and associated chain sprockets

bsi.

...making excellence a habit.™

National foreword

This British Standard is the UK implementation of ISO 606:2015.

The UK participation in its preparation was entrusted to Technical Committee MCE/1, Chains and chain sprockets for power transmission.

A list of organizations represented on this committee can be obtained on request to its secretary.

This publication does not purport to include all the necessary provisions of a contract. Users are responsible for its correct application.

© The British Standards Institution 2015.

Published by BSI Standards Limited 2015

ISBN 978 0 580 82025 0

ICS 21.220.30

Compliance with a British Standard cannot confer immunity from legal obligations.

This British Standard was published under the authority of the Standards Policy and Strategy Committee on 31 August 2015.

Amendments/corrigenda issued since publication

Date	Text affected
------	---------------

INTERNATIONAL STANDARD

BS ISO 606:2015

ISO
606

Fourth edition
2015-08-15

Short-pitch transmission precision roller and bush chains, attachments and associated chain sprockets

*Chaînes de transmission de précision à rouleaux et à douilles, plaques-
attaches et roues dentées correspondantes*



Reference number
ISO 606:2015(E)

© ISO 2015



COPYRIGHT PROTECTED DOCUMENT

© ISO 2015, Published in Switzerland

All rights reserved. Unless otherwise specified, no part of this publication may be reproduced or utilized otherwise in any form or by any means, electronic or mechanical, including photocopying, or posting on the internet or an intranet, without prior written permission. Permission can be requested from either ISO at the address below or ISO's member body in the country of the requester.

ISO copyright office
Ch. de Blandonnet 8 • CP 401
CH-1214 Vernier, Geneva, Switzerland
Tel. +41 22 749 01 11
Fax +41 22 749 09 47
copyright@iso.org
www.iso.org

Contents

Page

Foreword	v
Introduction	vi
1 Scope	1
2 Normative references	1
3 Chains	2
3.1 Nomenclature of assemblies and components.....	2
3.2 Designation.....	4
3.3 Dimensions.....	4
3.4 Performance requirements.....	6
3.4.1 General.....	6
3.4.2 Tensile testing.....	7
3.4.3 Preloading.....	7
3.4.4 Length validation.....	7
3.4.5 Dynamic testing.....	7
3.5 Marking.....	8
3.6 Cranked links.....	8
4 Attachments	12
4.1 Nomenclature.....	12
4.2 General.....	13
4.3 Designation.....	13
4.4 Dimensions.....	14
4.5 Manufacture.....	14
4.6 Marking.....	14
5 Chain sprockets	16
5.1 General.....	16
5.2 Nomenclature.....	16
5.3 Diametral dimensions of sprocket rim.....	19
5.3.1 Nomenclature.....	19
5.3.2 Dimensions.....	19
5.4 Sprocket tooth gap forms.....	20
5.4.1 Nomenclature.....	20
5.4.2 Dimensions.....	20
5.5 Tooth heights and tip diameters.....	21
5.5.1 Nomenclature.....	21
5.5.2 Dimensions.....	21
5.6 Sprocket rim profiles.....	22
5.6.1 Nomenclature.....	22
5.6.2 Dimensions.....	22
5.7 Radial run-out.....	22
5.8 Axial run-out (wobble).....	23
5.9 Pitch accuracy of sprocket teeth.....	23
5.10 Number of teeth.....	23
5.11 Bore tolerance.....	23
5.12 Marking.....	23
Annex A (normative) Pitch circle diameters	24
Annex B (informative) Equivalent chain designations	26
Annex C (informative) Method of calculating chain minimum dynamic strength	27
Annex D (informative) Method of determining maximum test force F_{max} when conducting dynamic strength conformance test	30
Annex E (informative) Examples of methods used to avoid an excessive increase in the rate	

of stress during the tensile test	31
Annex F (informative) Methods used to approximate the minimum dynamic test values for multiplex chains	34
Bibliography	35

Foreword

ISO (the International Organization for Standardization) is a worldwide federation of national standards bodies (ISO member bodies). The work of preparing International Standards is normally carried out through ISO technical committees. Each member body interested in a subject for which a technical committee has been established has the right to be represented on that committee. International organizations, governmental and non-governmental, in liaison with ISO, also take part in the work. ISO collaborates closely with the International Electrotechnical Commission (IEC) on all matters of electrotechnical standardization.

The procedures used to develop this document and those intended for its further maintenance are described in the ISO/IEC Directives, Part 1. In particular the different approval criteria needed for the different types of ISO documents should be noted. This document was drafted in accordance with the editorial rules of the ISO/IEC Directives, Part 2 (see www.iso.org/directives).

Attention is drawn to the possibility that some of the elements of this document may be the subject of patent rights. ISO shall not be held responsible for identifying any or all such patent rights. Details of any patent rights identified during the development of the document will be in the Introduction and/or on the ISO list of patent declarations received (see www.iso.org/patents).

Any trade name used in this document is information given for the convenience of users and does not constitute an endorsement.

For an explanation on the meaning of ISO specific terms and expressions related to conformity assessment, as well as information about ISO's adherence to the WTO principles in the Technical Barriers to Trade (TBT) see the following URL: [Foreword - Supplementary information](#)

The committee responsible for this document is ISO/TC 100, *Chains and chain sprockets for power transmission and conveyors*.

This fourth edition cancels and replaces the third edition (ISO 606:2004), which has been technically revised. It also incorporates Technical Corrigendum ISO 606:2004/Cor. 1:2006.

Introduction

The provisions of this revised International Standard have been established by including sizes of chains used by the majority of countries in the world, and by unifying dimensions, strengths and other data which differed in current national standards, while eliminating those for which it was considered a universal usage had not been established.

The whole field of application open to this medium of transmission has been covered by the ranges of chains already established. To achieve this, the sizes of 6,35 mm pitch to 76,2 mm pitch inclusive have been duplicated, on the one hand, by the inclusion of chains derived from standards originating and centred around ANSI, and on the other by chains representing the unification of the principal standards originating in Europe, the two being complementary for the coverage of the widest possible field of application.

The ANSI chain reference numbers (25, 35, 40, 50, etc.) are used world-wide and these numbers have now been introduced into this International Standard in place of the previous ISO reference numbers (04C, 06C, 08A, 10A, etc.) To assist in cross-referencing the ANSI and previous ISO numbers, details are included in [Annex B](#) of this International Standard.

The ANSI heavy series of chains (suffix H) are specified in this International Standard. The ANSI heavy series of chains differs from the ANSI standard series in that thicker plates are used.

The ANSI extra heavy series of chains (suffix HE) are now included. The ANSI extra heavy series are dimensionally as the ANSI heavy series (suffix H) but have a higher minimum ultimate tensile strength.

[Clause 4](#) covers specification details for K and M attachments, and extended pin attachments for use with short-pitch transmission roller and bush chains conforming with this International Standard.

[Clause 5](#), covering chain sprockets, represents the unification of all the relevant national standards in the world and includes, in particular, complete tolerances relating to tooth form.

The inclusion of the dimensions of the chains specified ensures complete interchangeability of any given size and provides interchangeability of individual links of chains.

Short-pitch transmission precision roller and bush chains, attachments and associated chain sprockets

1 Scope

This International Standard specifies the characteristics of short-pitch precision roller and bush chains with associated sprockets suitable for the mechanical transmission of power and allied applications. It covers dimensions, tolerances, length measurement, preloading, minimum tensile strengths and minimum dynamic strength.

Although [Clause 5](#) applies to chain sprockets for cycles and motor cycles, this International Standard is not applicable to their chains, which are covered by ISO 9633 and ISO 10190, respectively.

2 Normative references

The following documents, in whole or in part, are normatively referenced in this document and are indispensable for its application. For dated references, only the edition cited applies. For undated references, the latest edition of the referenced document (including any amendments) applies.

ISO 286-2:2010, *Geometrical product specifications (GPS) — ISO code system for tolerances on linear sizes — Part 2: Tables of standard tolerance classes and limit deviations for holes and shafts*

ISO 15654, *Fatigue test method for transmission precision roller chains*

3 Chains

3.1 Nomenclature of assemblies and components

The nomenclature of chain assemblies and their component parts is shown in [Figures 1](#) and [2](#) (which do not define the actual form of the chain plates).

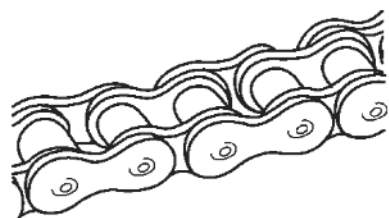

a) Simplex chain



b) Duplex chain

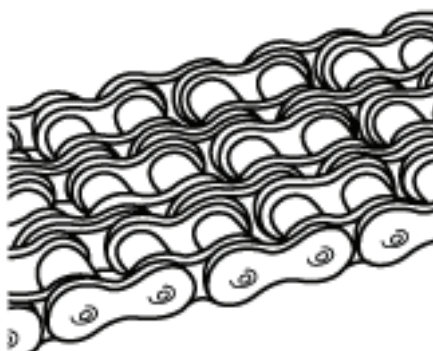

c) Triplex chain

Figure 1 — Types of roller chain assembly

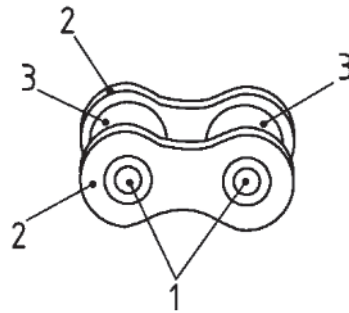

a) Inner link

Key for a)

- 1 bush
- 2 inner plate
- 3 roller

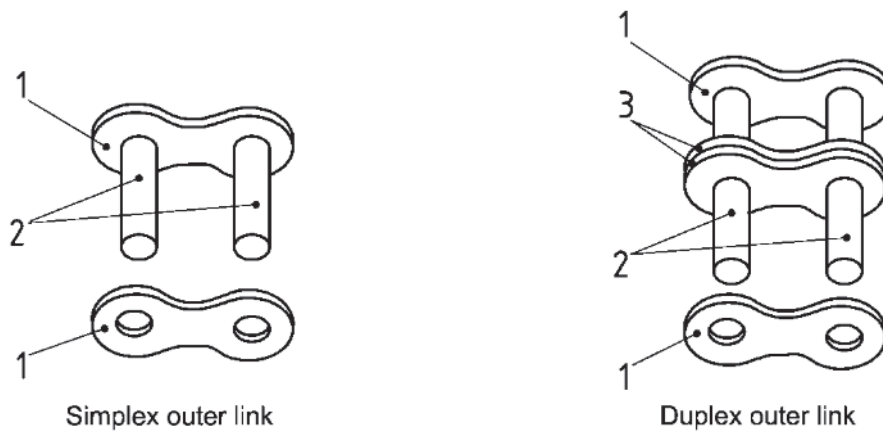

b) Outer links for riveting

Key for b)

- 1 outer plate
- 2 bearing pins
- 3 intermediate plate(s)

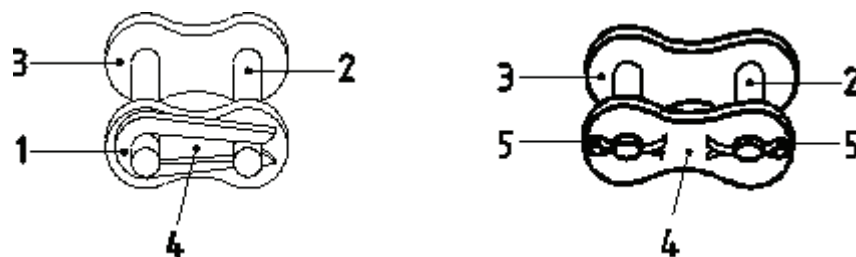

c) Detachable connecting links

Key for c)

- 1 spring clip fastener
- 2 fixed connecting pin
- 3 outer plate
- 4 detachable plate
- 5 cotter pin fastener

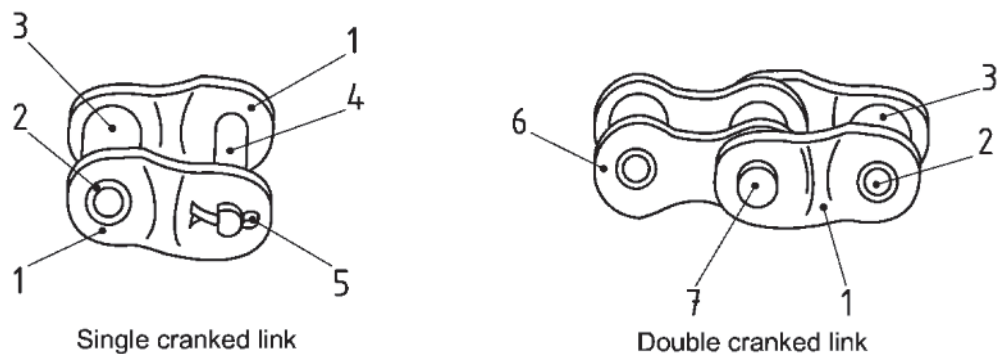

d) Cranked links

Key for d)

1	cranked plate	5	cotter pin fastener
2	bush	6	inner plate
3	roller	7	bearing pin, riveted
4	detachable connecting pin		

NOTE 1 The plate dimensions are specified in [Tables 1](#) and [2](#).

NOTE 2 Fasteners can be of various designs. Drawings indicate examples.

Figure 2 — Types of link

3.2 Designation

Chains are designated by the standard ISO chain number given in [Tables 1](#) and [2](#). The ISO chain numbers in [Table 1](#) are supplemented by a hyphenated suffix 1 for simplex chain, 2 for duplex chain and 3 for triplex chain, for example, 16B-1, 16B-2, 16B-3, 80-1, 80-2, 80-3. Chains 081, 083, 084 and 41 do not follow this procedure since they are normally available in simplex form only.

The chains designated in [Table 2](#) are the ANSI heavy and extra heavy series, which are also supplemented by a hyphenated suffix 1 for simplex chain, 2 for duplex chain and 3 for triplex chain, for example, 80H-1, 80H-2, 80H-3, 80HE-1, 80HE-2, 80HE-3.

3.3 Dimensions

Chains shall conform to the dimensions shown in [Figure 3](#) and given in [Tables 1](#) and [2](#). Maximum and minimum dimensions are specified to ensure interchangeability of links produced by different makers of chain. They represent limits for interchangeability, but are not the manufacturing tolerances.

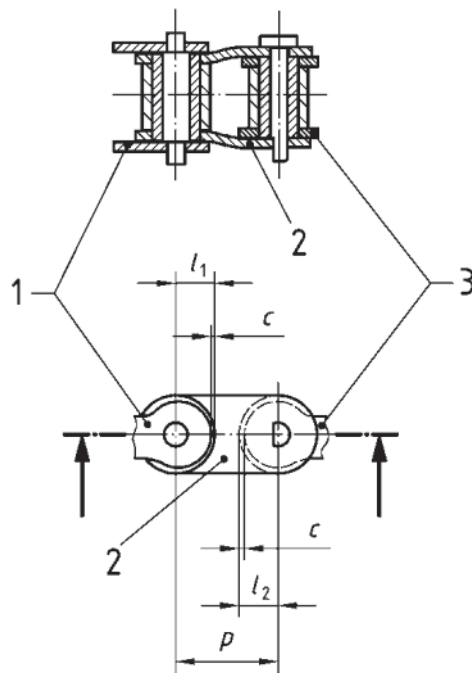

a) Cranked link

Key for a)

- c clearance between cranked link plates and straight plates available during articulation
- p pitch
- 1 outer plate
- 2 cranked plate
- 3 inner plate

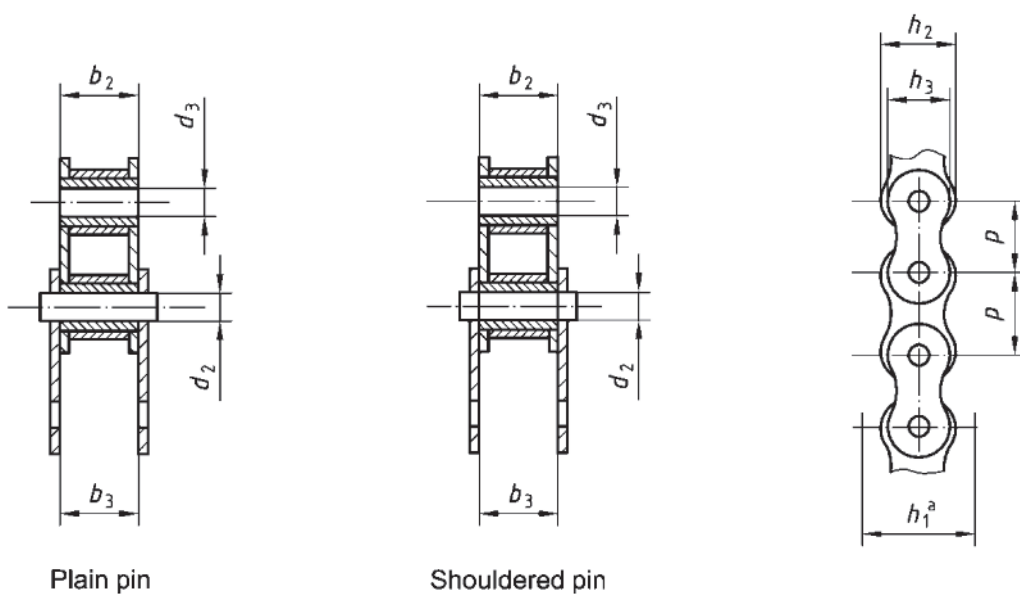

b) Sections through chain

Key for b)

- ^a Chain path depth is the minimum depth of channel through which the assembled chain will pass

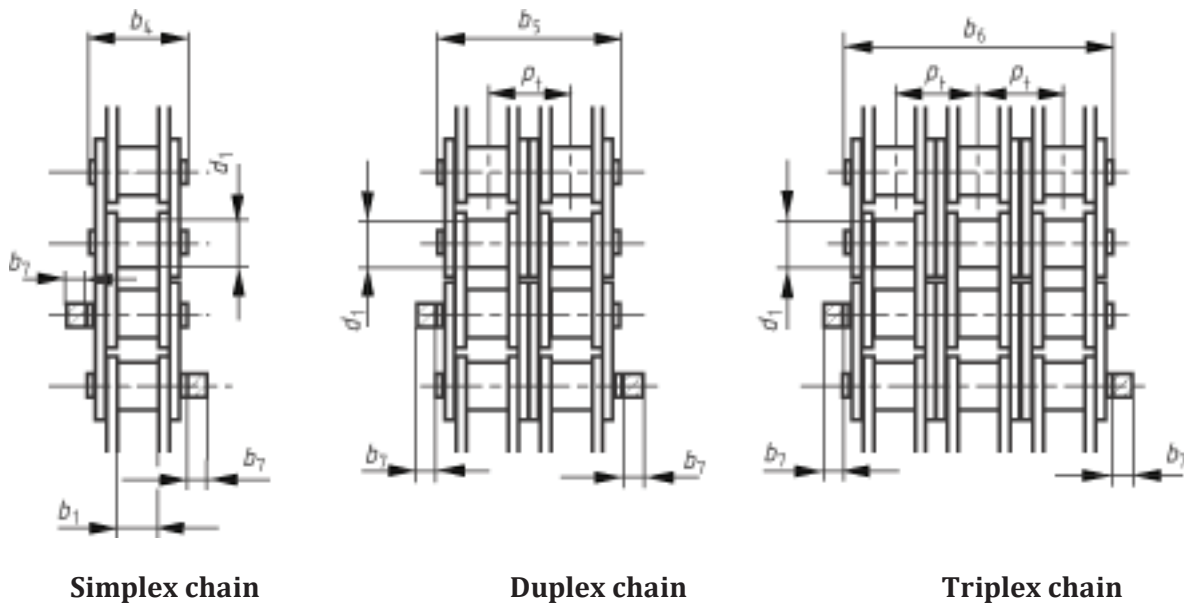

c) Types of chain

NOTE For the symbols, see [Table 1](#).

Figure 3 — Chains

The overall width of a simplex, duplex or triplex chain with a joint fastener is given by

a) for riveted pin end chains if the fastener is on one side only:

$$(b_4 + b_7) \text{ or } (b_5 + b_7) \text{ or } (b_6 + b_7);$$

b) for riveted pin end chains if the fastener is on two sides:

$$[b_4 + (2b_7)] \text{ or } [b_5 + (2b_7)] \text{ or } [b_6 + (2b_7)];$$

c) for headed pin end chains if the fastener is on one side only:

$$[b_4 + (1,6b_7)] \text{ or } [b_5 + (1,6b_7)] \text{ or } [b_6 + (1,6b_7)];$$

d) for headed pin end chains if the fastener is on two sides:

$$[b_4 + (3,2b_7)] \text{ or } [b_5 + (3,2b_7)] \text{ or } [b_6 + (3,2b_7)].$$

The overall width of chains wider than triplex is given by

$$b_4 + [p_t \times (\text{number of strands in chain} - 1)].$$

3.4 Performance requirements

3.4.1 General

WARNING — The test requirements are not to be taken as working loads. These loads could be selected, indirectly, using ISO 10823. The test results shall be invalid if the chain has previously been in service or stressed in any way (other than by preloading in accordance with [3.4.3](#)).

The tests given in [3.4.2](#) to [3.4.5](#) shall only be performed on unused, undamaged chains to determine whether the subject chain complies with the minimum requirements specified in [Tables 1](#) and [2](#).

3.4.2 Tensile testing

3.4.2.1 The minimum tensile strength is that value which shall be exceeded when a tensile force is applied to a sample tested to destruction in accordance with [3.4.2.2](#)

NOTE This minimum tensile strength is not a working load, but is intended primarily as a comparative figure between chains of various constructions.

3.4.2.2 Apply a tensile force slowly to the ends of a chain length containing at least five free pitches by means of fixtures permitting free movement on both sides of the chain centreline, in the normal plane of articulation. [Annex E](#) (informative) describes methods to consider using in order to avoid an excessive increase in the rate of stress being applied to the chain during the tensile test.

Failure shall be considered to have occurred at the first point where increasing extension is no longer accompanied by increasing force, i.e. the summit of the force/extension diagram. The force at this point shall exceed the minimum tensile strength stated in [Tables 1](#) and [2](#).

Tests in which failures occur adjacent to the shackles shall be disregarded.

3.4.2.3 The tensile test shall be considered as a destructive test. Even though a chain might not visibly fail when subjected to a force equivalent to the minimum tensile strength, it will have been stressed beyond the yield point and will be unfit for service.

3.4.2.4 These requirements do not apply to cranked links, connecting links or chains with attachments, as their tensile strength could be reduced.

3.4.3 Preloading

Chains manufactured in conformance with this International Standard shall be preloaded by applying a minimum tensile force equivalent to 30 % of the minimum tensile strength given in [Tables 1](#) and [2](#).

3.4.4 Length validation

Measurement of chains shall take place after preloading but before lubrication.

The standard length for measurement shall be a minimum of

- a) 610 mm for ISO chain numbers 25 to 12B and 081 to 41 inclusive, or
- b) 1 220 mm for ISO chain numbers 80 to 72B inclusive.

The chain shall be supported throughout its entire length and the measuring force specified in [Tables 1](#) and [2](#) shall be applied.

The measured length shall be the nominal length $^{+0,15}_0\%$, except for chains with attachments when it shall be the nominal length $^{+0,30}_0\%$.

The length accuracy of chains which have to work in parallel can be matched within closer tolerances.

3.4.5 Dynamic testing

Chains in conformance with this International Standard shall survive a conformance test, as specified in ISO 15654, using the dynamic strength values given in [Tables 1](#) or [2](#) for the particular chain. These requirements do not apply to cranked links, connecting links or chains with attachments, as their dynamic strength could be reduced. The methods used for calculating the minimum dynamic strength are given in [Annex C](#). The method for determining the maximum test force for the conformance test is given in [Annex D](#). The informative [Annex F](#) describes two methods used to approximate the minimum dynamic test values for multiplex chains.

3.5 Marking

The chain shall be marked with the manufacturer's name or trademark. The chain number quoted in [Tables 1](#) or [2](#) should be marked on the chain, with the exception of chains in the ANSI extra heavy series (suffix HE) where the manufacturer can mark the chains with their own designation.

3.6 Cranked links

Cranked links should not be used with the heavy and extra heavy series chains or on chains which are intended for highly stressed applications. Where a cranked link is used a reduction in performance will occur.

Table 1 — Principal chain dimensions, measuring forces, tensile strengths and dynamic strength values (see Figures 1 and 3)

ISO Chain number ^a	Pitch	p	d ₁	Maximum roller diameter	b ₁	Minimum width between inner plates	d ₂	Maximum bearing pin body diameter	d ₃	Minimum bush bore	h ₁	Minimum chain path depth	h ₂	Maximum inner plate depth	h ₃	Maximum outer or intermediate plate depth	Minimum cranked link dimensions ^b			l ₂	c	Pt	Transverse pitch	b ₂	Maximum width over inner link	b ₃	Maximum width over bearing pins			b ₇	Maximum additional width for joint fastener ^c	Measuring force			Minimum tensile strength			F _d	Minimum dynamic strength Simplex ^d										
																	l ₁	l ₂	c								b ₄	b ₅	b ₆			N	Simplex	Duplex	Triplex	F _u	Simplex			Duplex	Triplex	N	Simplex	Duplex	Triplex	F _u	Simplex	Duplex	Triplex
25	6,35	3,30 B	3,10	2,31	2,34	6,27	6,02	5,21	2,65	3,08	0,10	6,40	4,80	4,85	9,1	15,5	21,8	2,5	50	100	150	3,5	7,0	10,5	630																								
35	9,525	5,08 B	4,68	3,60	3,62	9,30	9,05	7,81	3,97	4,60	0,10	10,13	7,46	7,52	13,2	23,4	33,5	3,3	70	140	210	7,9	15,8	23,7	1410																								
05B	8,00	5,00	3,00	2,31	2,36	7,37	7,11	7,11	3,71	3,71	0,08	5,64	4,77	4,90	8,6	14,3	19,9	3,1	50	100	150	4,4	7,8	11,1	820																								
06B	9,525	6,35	5,72	3,28	3,33	8,52	8,26	8,26	4,32	4,32	0,08	10,24	8,53	8,66	13,5	23,8	34,0	3,3	70	140	210	8,9	16,9	24,9	1 290																								
40	12,70	7,92	7,85	3,98	4,00	12,33	12,07	10,42	5,29	6,10	0,08	14,38	11,17	11,23	17,8	32,3	46,7	3,9	120	250	370	13,9	27,8	41,7	2 480																								
08B	12,70	8,51	7,75	4,45	4,50	12,07	11,81	10,92	5,66	6,12	0,08	13,92	11,30	11,43	17,0	31,0	44,9	3,9	120	250	370	17,8	31,1	44,5	2 480																								
081	12,70	7,75	3,30	3,66	3,71	10,17	9,91	9,91	5,36	5,36	0,08	—	5,80	5,93	10,2	—	—	1,5	125	—	—	8,0	—	—	—																								
083	12,70	7,75	4,88	4,09	4,14	10,56	10,30	10,30	5,36	5,36	0,08	—	7,90	8,03	12,9	—	—	1,5	125	—	—	11,6	—	—	—																								
084	12,70	7,75	4,88	4,09	4,14	11,41	11,15	11,15	5,77	5,77	0,08	—	8,80	8,93	14,8	—	—	1,5	125	—	—	15,6	—	—	—																								
41	12,70	7,77	6,25	3,60	3,62	10,17	9,91	8,51	4,35	5,03	0,08	—	9,06	9,12	14,0	—	—	2,0	80	—	—	6,7	—	—	1 340																								
50	15,875	10,16	9,40	5,09	5,12	15,35	15,09	13,02	6,61	7,62	0,10	18,11	13,84	13,89	21,8	39,9	57,9	4,1	200	390	590	21,8	43,6	65,4	3 850																								
10B	15,875	10,16	9,65	5,08	5,13	14,99	14,73	13,72	7,11	7,62	0,10	16,59	13,28	13,41	19,6	36,2	52,8	4,1	200	390	590	22,2	44,5	66,7	3 330																								
60	19,05	11,91	12,57	5,96	5,98	18,34	18,10	15,62	7,90	9,15	0,10	22,78	17,75	17,81	26,9	49,8	72,6	4,6	280	560	840	31,3	62,6	93,9	5 490																								
12B	19,05	12,07	11,68	5,72	5,77	16,39	16,13	16,13	8,33	8,33	0,10	19,46	15,62	15,75	22,7	42,2	61,7	4,6	280	560	840	28,9	57,8	86,7	3 720																								
80	25,40	15,88	15,75	7,94	7,96	24,39	24,13	20,83	10,55	12,20	0,13	29,29	22,60	22,66	33,5	62,7	91,9	5,4	500	1 000	1 490	55,6	111,2	166,8	9 550																								
16B	25,40	15,88	17,02	8,28	8,33	21,34	21,08	21,08	11,15	11,15	0,13	31,88	25,45	25,58	36,1	68,0	99,9	5,4	500	1 000	1 490	60,0	106,0	160,0	9 530																								
100	31,75	19,05	18,90	9,54	9,56	30,48	30,17	26,04	13,16	15,24	0,15	35,76	27,45	27,51	41,1	77,0	113,0	6,1	780	1 560	2 340	87,0	174,0	261,0	14 600																								
20B	31,75	19,05	19,56	10,19	10,24	26,68	26,42	26,42	13,89	13,89	0,15	36,45	29,01	29,14	43,2	79,7	116,1	6,1	780	1 560	2 340	95,0	170,0	250,0	13 500																								
120	38,10	22,23	25,22	11,11	11,14	36,55	36,2	31,24	15,80	18,27	0,18	45,44	35,45	35,51	50,8	96,3	141,7	6,6	1 110	2 220	3 340	125,0	250,0	375,0	20 500																								
24B	38,10	25,40	25,40	14,63	14,68	33,73	33,4	33,40	17,55	17,55	0,18	48,36	37,92	38,05	53,4	101,8	150,2	6,6	1 110	2 220	3 340	160,0	280,0	425,0	19 700																								
140	44,45	25,40	25,22	12,71	12,74	42,67	42,23	36,45	18,42	21,32	0,20	48,87	37,18	37,24	54,9	103,6	152,4	7,4	1 510	3 020	4 540	170,0	340,0	510,0	27 300																								

Table 1 — (continued)

ISO Chain number ^a	Pitch	p	Maximum roller diameter	d ₁	Minimum width between inner plates	b ₁	Maximum bearing pin body diameter	d ₂	Minimum bush bore	d ₃	Minimum chain path depth	h ₁	Maximum inner plate depth	h ₂	Maximum outer or intermediate plate depth	h ₃	Minimum cranked link dimensions ^b				Transverse pitch	d _t	Maximum width over inner link	b ₂	Minimum width between outer plates	Maximum width over bearing pins						Maximum additional width for joint fastener ^c			Measuring force			Minimum tensile strength				Minimum dynamic strength					
																	l ₁	l ₂	c	Chain						Simplex	Duplex	Triplex	b ₄	b ₅	b ₆	b ₇	N	Simplex	Duplex	Triplex	N	Simplex	Duplex	Triplex	F _u		N	Simplex	Duplex	Triplex	F _d
28B	44,45	27,94	30,99	15,90	15,95	37,08	37,08	37,08	19,51	19,51	0,20	59,56	46,58	46,71	65,1	124,7	184,3	7,4	1 510	3 020	4 540	200,0	360,0	530,0	27 100																						
160	50,80	28,58	31,55	14,29	14,31	48,74	48,26	41,68	21,04	24,33	0,20	58,55	45,21	45,26	65,5	124,2	182,9	7,9	2 000	4 000	6 010	223,0	446,0	669,0	34 800																						
32B	50,80	29,21	30,99	17,81	17,86	42,29	42,29	42,29	22,20	22,20	0,20	58,55	45,7	45,70	67,4	126,0	184,5	7,9	2 000	4 000	6 010	250,0	450,0	670,0	29 900																						
180	57,15	35,71	35,48	17,46	17,49	54,86	54,30	46,86	23,65	27,36	0,20	65,84	50,85	50,90	73,9	140,0	206,0	9,1	2 670	5 340	8 010	281,0	562,0	843,0	44 500																						
200	63,50	39,68	37,85	19,85	19,87	60,93	60,33	52,07	26,24	30,36	0,20	71,55	54,88	54,94	80,3	151,9	223,5	10,2	3 110	6 230	9 340	347,0	694,0	1 041,0	53 600																						
40B	63,50	39,37	38,10	22,89	22,94	53,49	52,96	52,96	27,76	27,76	0,20	72,29	55,75	55,88	82,6	154,9	227,2	10,2	3 110	6 230	9 340	355,0	630,0	950,0	41 800																						
240	76,20	47,63	47,35	23,81	23,84	73,13	72,39	62,49	31,45	36,40	0,20	87,83	67,81	67,87	95,5	183,4	271,3	10,5	4 450	8 900	13 340	500,0	1 000,0	1 500,0	73 100																						
48B	76,20	48,26	45,72	29,24	29,29	64,52	63,88	63,88	33,45	33,45	0,20	91,21	70,56	70,69	99,1	190,4	281,6	10,5	4 450	8 900	13 340	560,0	1 000,0	1 500,0	63 600																						
56B	88,90	53,98	53,34	34,32	34,37	78,64	77,85	77,85	40,61	40,61	0,20	106,60	81,33	81,46	114,6	221,2	327,8	11,7	6 090	12 190	20 000	850,0	1 600,0	2 240,0	88 900																						
64B	101,60	63,50	60,96	39,40	39,45	91,08	90,17	90,17	47,07	47,07	0,20	119,89	92,02	92,15	130,9	250,8	370,7	13,0	7 960	15 920	27 000	1 120,0	2 000,0	3 000,0	106 900																						
72B	114,30	72,39	68,58	44,48	44,53	104,67	103,63	103,63	53,37	53,37	0,20	136,27	103,81	103,94	147,4	283,7	420,0	14,3	10 100	20 190	33 500	1 400,0	2 500,0	3 750,0	132 700																						

^a For details of heavy and extra heavy series chains, see Table 2.
^b Cranked links are not recommended for use of highly stressed applications.
^c The actual dimensions will depend on the type of fastener used, they should not exceed the dimensions given, details of which should be obtained by the purchaser from the manufacturer.
^d These dynamic strength values do not apply to cranked links or connecting links or chains with attachments.
^e Whilst dynamic test values for duplex and triplex chains should not be proportioned from the simplex test value, Appendix F details methods of calculation for when an approximation is required.
^f Dynamic strength values are based on test specimens each of 5 free pitches except for 180, 200, 40B, 240, 48B, 56B, 64B and 72B chains which are based on test specimens each of 3 free pitches. See Annex C for method of calculation.
^g Bush diameter.

Table 2 — Principal dimensions, measuring forces, tensile strengths and dynamic strength values of ANSI heavy and extra heavy series chains

ISO Chain number ^a	Pitch		Maximum roller diameter		Minimum width between inner plates		Maximum bearing pin body diameter		Minimum bush bore		Minimum chain path depth		Maximum inner plate depth		Intermediate plate depth		Minimum cranked link dimensions ^b			Transverse pitch		Maximum width over inner link		Minimum width between outer plates		Maximum width over bearing pins			Maximum additional width for joint fastener ^c			Measuring force			Minimum tensile strength			Minimum dynamic strength ^{d, e, f}		
	p	d _p	d _{p1}	d _{p2}	d _{p3}	h ₁	h ₂	h ₃	l ₁	l ₂	c	ϕt	b ₂	b ₃	b ₄	b ₅	b ₆	b ₇	S _{simplex}	D _{duplex}	T _{triplex}	l ₁	l ₂	c	b ₄	b ₅	b ₆	b ₇	S _{simplex}	D _{duplex}	T _{triplex}	F _u	F _u	F _d	N	N	N	F _d	N	N
	mm																																							
60H	19,05	11,91	12,57	5,96	5,98	18,34	18,10	15,62	7,90	9,15	0,10	26,11	19,43	19,48	30,2	56,3	82,4	4,6	280	560	840	31,3	62,6	93,9	6 330															
80H	25,40	15,88	15,75	7,94	7,96	24,39	24,13	20,83	10,55	12,20	0,13	32,59	24,28	24,33	37,4	70,0	102,6	5,4	500	1 000	1 490	55,6	112,2	166,8	10 700															
100H	31,75	19,05	18,90	9,54	9,56	30,48	30,17	26,04	13,16	15,24	0,15	39,09	29,10	29,16	44,5	83,6	122,7	6,1	780	1 560	2 340	87,0	174,0	261,0	16 000															
120H	38,10	22,23	25,22	11,11	11,14	36,55	36,20	31,24	15,80	18,27	0,18	48,87	37,18	37,24	55,0	103,9	152,8	6,6	1 110	2 220	3 340	125,0	250,0	375,0	22 200															
140H	44,45	25,40	25,22	12,71	12,74	42,67	42,23	36,45	18,42	21,32	0,20	52,20	38,86	38,91	59,0	111,2	163,4	7,4	1 510	3 020	4 540	170,0	340,0	510,0	29 200															
160H	50,80	28,58	31,55	14,29	14,31	48,74	48,26	41,66	21,04	24,33	0,20	61,90	46,88	46,94	69,4	131,3	193,2	7,9	2 000	4 000	6 010	223,0	446,0	669,0	36 900															
180H	57,15	35,71	35,48	17,46	17,49	54,86	54,30	46,86	23,65	27,36	0,20	69,16	52,55	52,55	77,3	146,5	215,7	9,1	2 670	5 340	8 010	281,0	562,0	843,0	46 900															
200H	63,50	39,68	37,85	19,85	19,87	60,93	60,33	52,07	26,24	30,36	0,20	78,31	58,29	58,34	87,1	165,4	243,7	10,2	3 110	6 230	9 340	347,0	694,0	1 041,0	58 700															
240H	76,20	47,63	47,35	23,81	23,84	73,13	72,39	62,49	31,45	36,40	0,20	101,22	74,54	74,60	111,4	212,6	313,8	10,5	4 450	8 900	13 340	500,0	1 000,0	1 500,0	84 400															
60HE	19,05	11,91	12,57	5,96	5,98	18,34	18,10	15,62	7,90	9,15	0,10	26,11	19,43	19,48	30,2	56,3	82,4	4,6	280	560	840	41,5	83,0	124,5	6 330															
80HE	25,40	15,88	15,75	7,94	7,96	24,39	24,13	20,83	10,55	12,20	0,13	32,59	24,28	24,33	37,4	70,0	102,6	5,4	500	1 000	1 490	69,2	138,4	207,6	10 700															
100HE	31,75	19,05	18,90	9,54	9,56	30,48	30,17	26,04	13,16	15,24	0,15	39,09	29,10	29,16	44,5	83,6	122,7	6,1	780	1 560	2 340	104,0	208,0	312,0	16 000															
120HE	38,10	22,23	25,22	11,11	11,14	36,55	36,20	31,24	15,80	18,27	0,18	48,87	37,18	37,24	55,0	103,9	152,8	6,6	1 110	2 220	3 340	146,0	292,0	438,0	22 200															
140HE	44,45	25,40	25,22	12,71	12,74	42,67	42,23	36,45	18,42	21,32	0,20	52,20	38,86	38,91	59,0	111,2	163,4	7,4	1 510	3 020	4 540	194,0	388,0	582,0	29 200															
160HE	50,80	28,58	31,55	14,29	14,31	48,74	48,26	41,66	21,04	24,33	0,20	61,90	46,88	46,94	69,4	131,3	193,2	7,9	2 000	4 000	6 010	250,0	500,0	750,0	36 900															
180HE	57,15	35,71	35,48	17,46	17,49	54,86	54,30	46,86	23,65	27,36	0,20	69,16	52,55	52,55	77,3	146,5	215,7	9,1	2 670	5 340	8 010	311,0	622,0	933,0	46 900															
200HE	63,50	39,68	37,85	19,85	19,87	60,93	60,33	52,07	26,24	30,36	0,20	78,31	58,29	58,34	87,1	165,4	243,7	10,2	3 110	6 230	9 340	416,0	832,0	1 248,0	58 700															
240HE	76,20	47,63	47,35	23,81	23,84	73,13	72,39	62,49	31,45	36,40	0,20	101,22	74,54	74,60	111,4	212,6	313,8	10,5	4 450	8 900	13 340	664,0	1 328,0	1 992,0	84 400															

^a For details of standard series chains, see Table 1.
^b Cranked links are not recommended for use on highly stressed applications.
^c The actual dimensions will depend on the type of fastener used, but they should not exceed the dimensions given, details of which should be obtained by the purchaser from the manufacturer.
^d These dynamic strength values do not apply to cranked links or connecting links or chains with attachments.
^e Whilst dynamic test values for duplex and triplex chains should not be proportioned from the simplex test value, Appendix F details methods of calculation for when an approximation is required.
^f Dynamic strength values are based on test specimens each of 5 free pitches except for 180H, 180HE, 200H, 200HE, 240H and 240HE chains which are based on test specimens each of 3 free pitches.
 See Annex C for method of calculation.

4 Attachments

4.1 Nomenclature

The nomenclature for chain attachments is given in [Figures 4, 5, 6 and 7](#), and in [Tables 1, 3, 4 and 5](#).

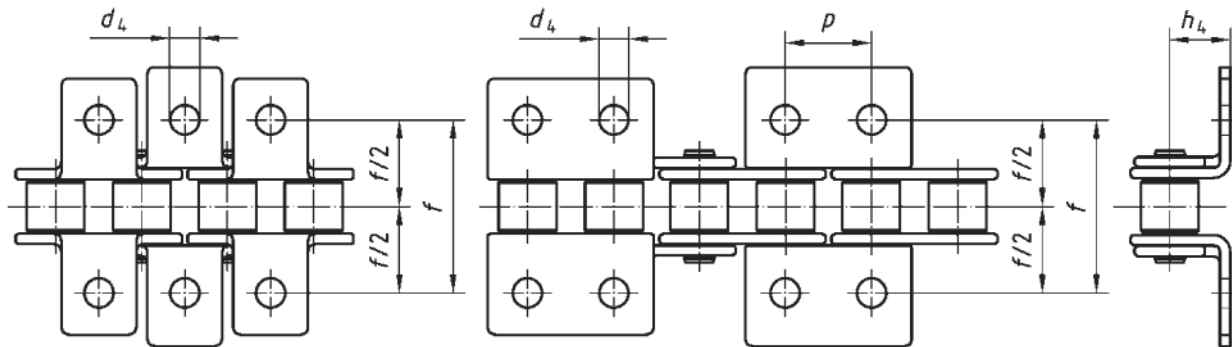

NOTE 1 For d_4 , h_4 and f , see [Table 3](#); for p , see [Table 1](#).

NOTE 2 K attachment plates can be positioned on either outer or inner links.

NOTE 3 K1 plates could be identical to K2 plates except that they have one hole located centrally.

NOTE 4 The assembly of K2 plates on adjacent links is not possible.

Figure 4 — K attachment plates

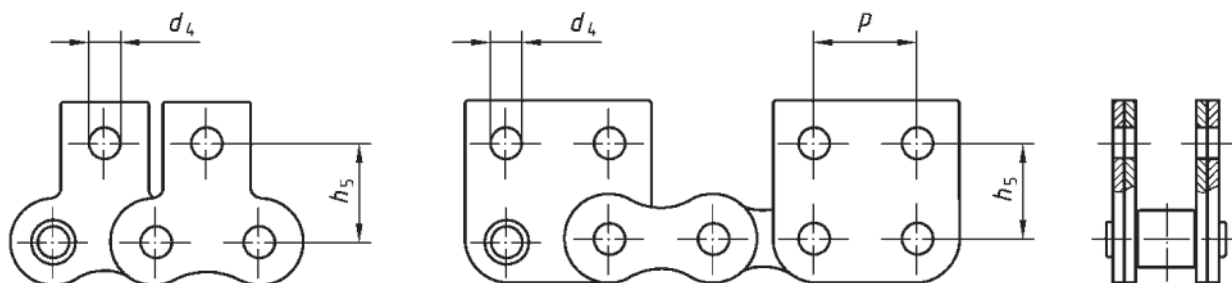

NOTE 1 For d_4 and h_5 , see [Table 4](#); for p , see [Table 1](#).

NOTE 2 M attachment plates can be positioned on either outer or inner links.

NOTE 3 M1 plates could be identical to M2 plates except that they have one hole located centrally.

NOTE 4 The assembly of M2 plates on adjacent links is not recommended.

Figure 5 — M attachment plates

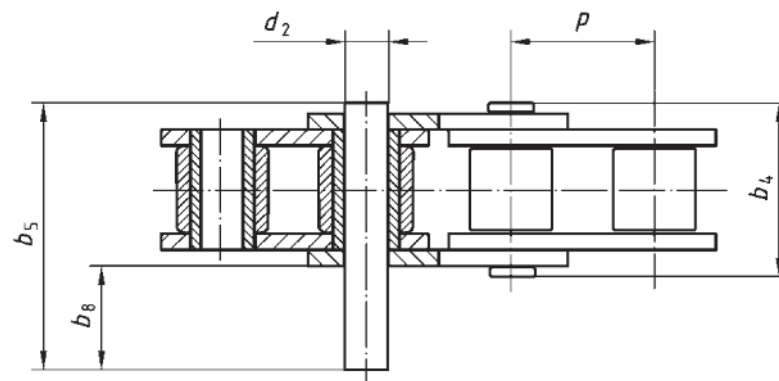

NOTE For b_4 and p , see [Table 1](#); for b_5 , b_8 and d_2 , see [Table 5](#).

Figure 6 — Extended bearing pins (based on duplex pin) — Type X

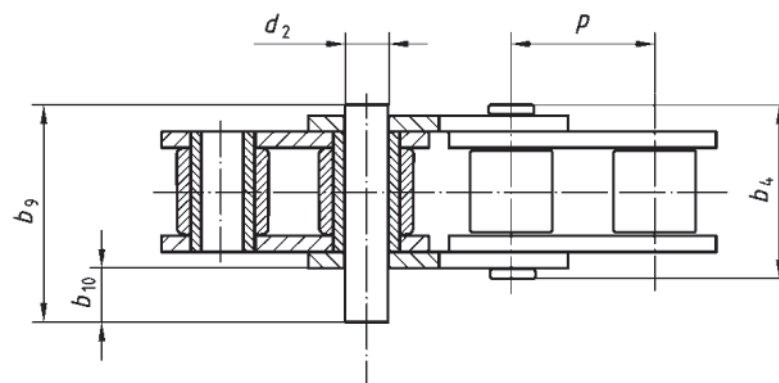

NOTE For b_4 and p , see [Table 1](#); for b_9 , b_{10} and d_2 , see [Table 5](#).

Figure 7 — Extended bearing pins (commonly used in “ANSI” series) — Type Y

4.2 General

Except when otherwise stated, the characteristics, dimensions and tests for the chain with attachments shall be in accordance with [Clause 3](#).

4.3 Designation

Three types of attachment are given, with the common dimensional basis as given in [Tables 3, 4](#) and [5](#). Their designation and distinguishing features are as follows:

- a) K attachments, as shown in [Figure 4](#):
 - 1) K1, with one attachment hole centrally located in each platform;
 - 2) K2, with two attachment holes longitudinally located;
- b) M attachments, as shown in [Figure 5](#):
 - 1) M1, with one attachment hole centrally located in the plate;

- 2) M2, with two attachment holes longitudinally located;
- c) Extended pin: with the bearing pin extended on one side of the chain as shown in [Figures 6](#) and [7](#). Alternative pin extensions are shown, one based on the use of the duplex pin (see [Figure 6](#)) and the other based on those extended pins commonly used in “ANSI” series chains (see [Figure 7](#)).

4.4 Dimensions

Attachments shall conform to the dimensions given in [Tables 3, 4](#) and [5](#).

4.5 Manufacture

The actual form of the attachment plates is left to the discretion of the manufacturer. K attachment plates are normally bent from M attachment plates.

The length of the attachment plate is also left to the discretion of the manufacturer, but should be sufficient to accommodate the two attachment holes longitudinally in the case of Type K2 and not interfere with the working of the adjoining links. A common length could be adopted for both Type K1 and K2.

4.6 Marking

It is not a requirement that K and M attachment plates be marked.

The marking of the extended pin chain shall be the same as that which would be shown on a chain with no attachments (see [3.5](#)).

Table 3 — Attachment plate K — Dimensions (see [Figure 4](#))

ISO chain number	Platform height	Minimum hole diameter	Traverse distance between hole centres
	h_4 mm	d_4 mm	f mm
35	6,4	2,6	19,0
40	7,9	3,3	25,4
08B	8,9	4,3	25,4
50	10,3	5,1	31,8
10B	10,3	5,3	31,8
60	11,9	5,1	38,1
12B	13,5	6,4	38,1
80	15,9	6,6	50,8
16B	15,9	6,4	50,8
100	19,8	8,2	63,5
20B	19,8	8,4	63,5
120	23,0	9,8	76,2
24B	26,7	10,5	76,2
140	28,6	11,4	88,9
28B	28,6	13,1	88,9
160	31,8	13,1	101,6
32B	31,8	13,1	101,6
200	42,9	16,3	127,0

Table 4 — Attachment plate M — Dimensions (see [Figure 5](#))

ISO chain number	Height from chain centre line	Minimum diameter of holes
	h_5 mm	d_4 mm
35	9,5	2,6
40	12,7	3,3
08B	13,0	4,3
50	15,9	5,1
10B	16,5	5,3
60	18,3	5,1
12B	21,0	6,4
80	24,6	6,6
16B	23,0	6,4
100	31,8	8,2
20B	30,5	8,4
120	36,5	9,8
24B	36,0	10,5
140	44,4	11,4
160	50,8	13,1
200	63,5	16,3

Table 5 — Extended pin dimensions (see [Figures 6](#) and [7](#))

Dimensions in millimetres

ISO chain number	Pin extension		Pin extension ^a		Pin diameter
	Type "X"		Type "Y"		Types "X" and "Y"
	b_8 max.	b_5 max.	b_{10} max.	b_9 max.	d_2 max.
05B	7,1	14,3	—	—	2,31
35	12,3	23,4	10,2	21,9	3,60
06B	12,2	23,8	—	—	3,28
40	16,5	32,3	10,2	26,3	3,98
08B	15,5	31,0	—	—	4,45
50	20,6	39,9	12,7	32,6	5,09
10B	18,5	36,2	—	—	5,08
60	25,7	49,8	15,2	40,0	5,96
12B	21,5	42,2	—	—	5,72
80	32,2	62,7	20,3	51,7	7,94
16B	34,5	68,0	—	—	8,28
100	39,1	77,0	25,4	63,8	9,54
20B	39,4	79,7	—	—	10,19
120	48,9	96,3	30,5	78,6	11,11
24B	51,4	101,8	—	—	14,63
140	—	—	35,6	87,5	12,71
160	—	—	40,6	102,6	14,29

^a The pin extensions of Type "Y" are given as alternatives, as they are commonly used in "ANSI" series chains.

5 Chain sprockets

5.1 General

This clause gives specifications for chain sprockets for use with short-pitch transmission precision roller and bush chains conforming to [Clause 3](#) and specifies general criteria for ensuring correct meshing, operation and transmission of load when used under normal operating conditions.

5.2 Nomenclature

The nomenclature for chain sprockets is shown in [Figures 8](#), [9](#) and [10](#).

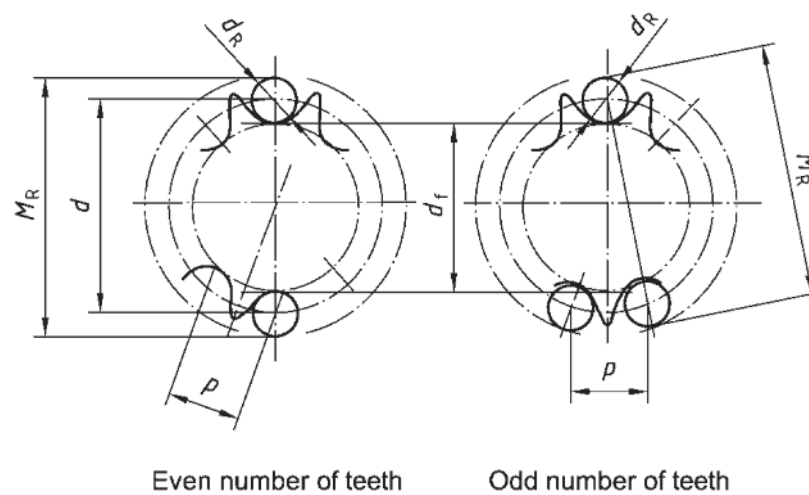

Key

- p chordal pitch, equal to chain pitch
- d_R measuring-pin diameter
- d pitch-circle diameter
- d_f root diameter
- M_R measurement over pins

NOTE This nomenclature is valid for both roller and bush chains.

Figure 8 — Chain sprocket diametral dimensions

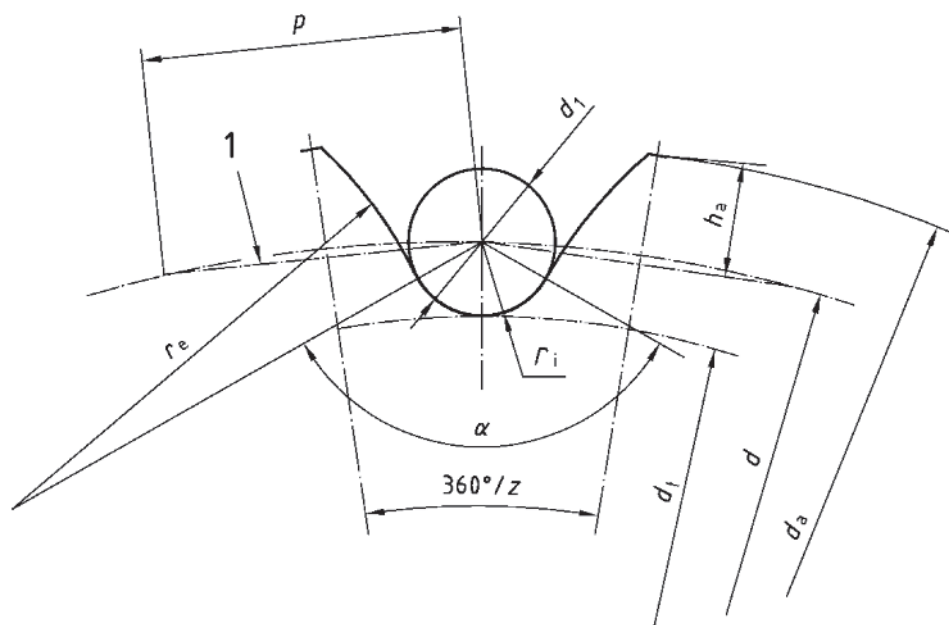

Key

- | | | | |
|----------|-------------------------------------|-------|-------------------------------------|
| 1 | pitch polygon | r_e | tooth-flank radius |
| p | chordal pitch, equal to chain pitch | h_a | height of tooth above pitch polygon |
| d | pitch-circle diameter | d_a | tip diameter |
| d_1 | maximum roller diameter | d_f | root diameter |
| r_i | roller-seating radius | z | number of teeth |
| α | roller-seating angle | | |

Figure 9 — Tooth gap forms

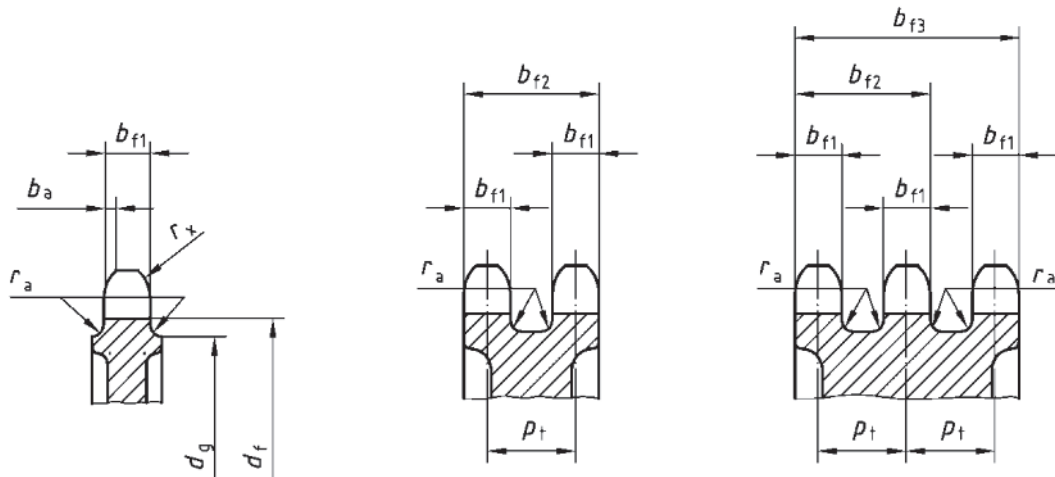

Key

b_a	tooth side relief	d_g	absolute maximum shroud diameter
b_{f1}	tooth width	p_t	strand transverse pitch
b_{f2}, b_{f3}	width over teeth	r_a	shroud fillet radius
d_f	sprocket root diameter	r_x	tooth side radius

NOTE For a sprocket rim in the axial plane sectioned through the centre of the tooth gap.

Figure 10 — Sprocket rim profiles

5.3 Diametral dimensions of sprocket rim

5.3.1 Nomenclature

See [Figure 8](#).

5.3.2 Dimensions

5.3.2.1 Pitch-circle diameter, d

The chain sprocket pitch-circle diameter, d , is given by

$$d = \frac{p}{\sin \frac{180^\circ}{z}}$$

[Annex A](#) gives the pitch-circle diameter for unit pitch as a function of the number of teeth.

5.3.2.2 Measuring-pin diameter, d_R

The chain sprocket measuring-pin diameter d_R is given by

$$d_R = d_1$$

(see [Figure 9](#))

with a tolerance of $^{+0,01}_0$ mm.

5.3.2.3 Root diameter, d_f

The chain sprocket root diameter d_f is given by

$$d_f = d - d_1$$

with a tolerance in accordance with [Table 6](#).

Table 6 — Root diameter tolerances

Dimensions in millimetres

Root diameter d_f	Tolerance
$d_f \leq 127$	0 - 0,25
$127 < d_f \leq 250$	0 - 0,3
$d_f > 250$	h11 ^a
^a See ISO 286-2.	

5.3.2.4 Measurement over pins

For an even number of teeth, the measurement over pins is given by

$$M_R = d + d_{R, \min}$$

For an odd number of teeth, the measurement over pins is given by

$$M_R = d \cos \frac{90^\circ}{z} + d_{R, \min}$$

The measurement over pins of sprockets with an even number of teeth shall be carried out over pins inserted in opposite tooth gaps.

The measurement over pins of sprockets with an odd number of teeth shall be carried out over pins in the tooth gaps most nearly opposite.

The limits of tolerance for measurement over pins are identical to those for the corresponding root diameters.

5.4 Sprocket tooth gap forms

5.4.1 Nomenclature

See [Figure 9](#).

5.4.2 Dimensions

5.4.2.1 General

The limits of the tooth gap form are determined by the minimum and maximum tooth gap forms. The actual tooth gap form, which is provided by cutting or an equivalent method, shall have tooth flanks of a form lying between the minimum and maximum flank radii and blending smoothly with the roller seating curve subtending the respective angles.

5.4.2.2 Minimum form

The corresponding values for r_e , r_i and α are given by

$$r_{e,\max} = 0,12d_1 (z + 2)$$

$$r_{i,\min} = 0,505d_1$$

$$\alpha_{\max} = 140^\circ - \frac{90^\circ}{z}$$

5.4.2.3 Maximum form

The corresponding values for r_e , r_i and α are given by

$$r_{e,\min} = 0,008d_1 (z^2 + 180)$$

$$r_{i,\max} = 0,505d_1 + 0,069\sqrt[3]{d_1}$$

$$\alpha_{\min} = 120^\circ - \frac{90^\circ}{z}$$

5.5 Tooth heights and tip diameters

5.5.1 Nomenclature

See [Figure 9](#).

5.5.2 Dimensions

The maximum and minimum values of the tip diameter d_a are given by

$$d_{a,\max} = d + 1,25p - d_1$$

$$d_{a,\min} = d + p \left(1 - \frac{1,6}{z} \right) - d_1$$

NOTE $d_{a,\min}$ and $d_{a,\max}$ can be applied arbitrarily both to the minimum and maximum gap forms, subject to the limitations imposed on the maximum diameter by the cutter.

To facilitate the construction of the tooth gap form to a large scale, the tooth height above the pitch polygon can be obtained from the following formulae:

$$h_{a,\max} = 0,625p - 0,5d_1 + \frac{0,8p}{z}$$

$$h_{a,\min} = 0,5 (p - d_1)$$

NOTE $h_{a,\max}$ is related to $d_{a,\max}$ and $h_{a,\min}$ to $d_{a,\min}$.

5.6 Sprocket rim profiles

5.6.1 Nomenclature

See [Figure 10](#).

5.6.2 Dimensions

5.6.2.1 Tooth width

Tooth width dimensions are given by the following:

a) for $P \leq 12,7$ mm:

- 1) $b_{f1} = 0,93b_1 : h14^{1)}$ for simplex chain sprockets;
- 2) $b_{f1} = 0,91b_1 : h14$ for duplex and triplex chain sprockets;
- 3) $b_{f1} = 0,88b_1 : h14$ for quadruplex chain wheels and above.

b) for $P > 12,7$ mm:

- 1) $b_{f1} = 0,95b_1 : h14$ for simplex chain sprockets;
- 2) $b_{f1} = 0,93b_1 : h14$ for duplex and triplex chain sprockets;
- 3) The formulae given in a) for quadruplex chains and above may be used by agreement between user and manufacturer.

5.6.2.2 Other dimensions

For all chains: b_{f2} and $b_{f3} = (\text{number of strands} - 1) \times p_t + b_{f1}$ (tolerance $h14^{2)}$ on b_{f1})

For all chains: $r_{x,nom} = p$

For chain numbers 081, 083, 084 and ~~41~~: $b_{a,nom} = 0,06p$

For all other chains: $b_{a,nom} = 0,13p$

For chain numbers 25 and 35: $d_g = p \cot \frac{180^\circ}{z} - 1,05h_2 - 1,00 - 2r_a$

For all other chains: $d_g = p \cot \frac{180^\circ}{z} - 1,04h_2 - (0,76 \text{ mm})$

5.7 Radial run-out

Radial run-out between the bore and root diameter shall not exceed a total indicator reading of greater than the larger of the two following values:

$(0,0008 d_f + 0,08)$ mm, or

0,15 mm,

up to a maximum of 0,76 mm.

1) See ISO 286-2.

2) See ISO 286-2.

5.8 Axial run-out (wobble)

Axial run-out, measured with reference to the bore and the flat part of the side face of the teeth, shall not exceed a total indicator reading of

$$(0,000 9 d_f + 0,08) \text{ mm},$$

up to a maximum of 1,14 mm.

For fabricated (welded) sprockets, 0,25 mm is acceptable if the above formula gives smaller values.

5.9 Pitch accuracy of sprocket teeth

Pitch accuracy of sprocket teeth is important and chain manufacturers should be consulted for details.

5.10 Number of teeth

This International Standard primarily applies to a number of teeth from 9 to 150 inclusive.

The preferred numbers of teeth are 17, 19, 21, 23, 25, 38, 57, 76, 95 and 114.

5.11 Bore tolerance

Unless otherwise agreed between manufacturer and purchaser, bore tolerance shall be H8³⁾.

5.12 Marking

Sprockets shall be marked with the following:

- a) manufacturer's name or trademark;
- b) number of teeth;
- c) chain designation (ISO chain number and/or manufacturer's equivalent).

3) See ISO 286-2.

Annex A (normative)

Pitch circle diameters

Table A.1 gives the correct pitch circle diameters for sprockets to suit a chain of unit pitch. The pitch circle diameters for sprockets to suit a chain of any other pitch are directly proportional to the pitch of the chain.

Table A.1 — Pitch circle diameters

Number of teeth <i>z</i>	Pitch circle diameter, <i>d</i> , for unit pitch ^a mm	Number of teeth <i>z</i>	Pitch circle diameter, <i>d</i> , for unit pitch ^a mm	Number of teeth <i>z</i>	Pitch circle diameter, <i>d</i> , for unit pitch ^a mm
9	2,923 8	32	10,202 3	55	17,516 6
10	3,236 1	33	10,520 1	56	17,834 7
11	3,549 4	34	10,838 0	57	18,152 9
12	3,863 7	35	11,155 8	58	18,471 0
13	4,178 6	36	11,473 7	59	18,789 2
14	4,494 0	37	11,791 6	60	19,107 3
15	4,809 7	38	12,109 6	61	19,425 5
16	5,125 8	39	12,427 5	62	19,743 7
17	5,442 2	40	12,745 5	63	20,061 9
18	5,758 8	41	13,063 5	64	20,380 0
19	6,075 5	42	13,381 5	65	20,698 2
20	6,392 5	43	13,699 5	66	21,016 4
21	6,709 5	44	14,017 6	67	21,334 6
22	7,026 6	45	14,335 6	68	21,652 8
23	7,343 9	46	14,653 7	69	21,971 0
24	7,661 3	47	14,971 7	70	22,289 2
25	7,978 7	48	15,289 8	71	22,607 4
26	8,296 2	49	15,607 9	72	22,925 6
27	8,613 8	50	15,926 0	73	23,243 8
28	8,931 4	51	16,244 1	74	23,562 0
29	9,249 1	52	16,562 2	75	23,880 2
30	9,566 8	53	16,880 3	76	24,198 5
31	9,884 5	54	17,198 4	77	24,516 7

^a This is sometimes referred to as “unit pitch circle diameter”.

Table A.1 (continued)

Number of teeth <i>z</i>	Pitch circle diameter, <i>d</i> , for unit pitch ^a mm	Number of teeth <i>z</i>	Pitch circle diameter, <i>d</i> , for unit pitch ^a mm	Number of teeth <i>z</i>	Pitch circle diameter, <i>d</i> , for unit pitch ^a mm
78	24,334 9	105	33,427 5	132	42,020 9
79	25,153 1	106	33,745 8	133	42,339 1
80	25,471 3	107	34,064 0	134	42,657 4
81	25,789 6	108	34,382 3	135	42,975 7
82	26,107 8	109	34,700 6	136	43,294 0
83	26,426 0	110	35,018 8	137	43,612 3
84	26,744 3	111	35,337 1	138	43,930 6
85	27,062 5	112	35,655 4	139	44,248 8
86	27,380 7	113	35,973 7	140	44,567 1
87	27,699 0	114	36,291 9	141	44,885 4
88	28,017 2	115	36,610 2	142	45,203 7
89	28,335 5	116	36,928 5	143	45,522 0
90	28,653 7	117	37,246 7	144	45,840 3
91	28,971 9	118	37,565 0	145	46,158 5
92	29,290 2	119	37,883 3	146	46,476 8
93	29,608 4	120	38,201 6	147	46,795 1
94	29,926 7	121	38,519 8	148	47,113 4
95	30,244 9	122	38,838 1	149	47,431 7
96	30,563 2	123	39,156 4	150	47,750 0
97	30,881 5	124	39,474 6	—	—
98	31,199 7	125	39,792 9	—	—
99	31,518 0	126	40,111 2	—	—
100	31,836 2	127	40,429 5	—	—
101	32,154 5	128	40,474 8	—	—
102	32,472 7	129	41,066 0	—	—
103	32,791 0	130	41,384 3	—	—
104	33,109 3	131	41,702 6	—	—

^a This is sometimes referred to as "unit pitch circle diameter".

Annex B (informative)

Equivalent chain designations

See [Table B.1](#).

Table B.1 — Equivalent chain designations

Chain pitch mm	ISO chain number	Previous ISO chain number
6,35	25	04C
9,525	35	06C
12,7	40	08A
12,7	41	085
15,875	50	10A
19,05	60	12A
25,4	80	16A
31,75	100	20A
38,1	120	24A
44,45	140	28A
50,8	160	32A
57,15	180	36A
63,5	200	40A
76,2	240	48A

Annex C (informative)

Method of calculating chain minimum dynamic strength

C.1 “ANSI” series chain

For 41 chain only:

$$F_d = K_s \times A_i \times p^{(-0,0008p)}$$

For all other chains:

$$F_d = K_s \times 0,118 \times p^{(2 - 0,0008p)}$$

where

F_d is the chain minimum dynamic strength at 3×10^6 cycles, in newtons (N);

A_i is 12,01 mm² for 41 chain only;

K_s is

- 115 N/mm² for 41 chain only;
- 134 N/mm² for chains up to and including 160;
- 139 N/mm² for chains 180 and above;

p is the chain pitch, in millimetres (mm).

NOTE Constant K_s is increased from 134 N/mm² to 139 N/mm² to allow for the reduction in the test specimen length from 5 free pitches to 3 free pitches when conducting the dynamic strength test.

C.2 “ANSI” series heavy and extra heavy chains

$$F_d = K_s \times 0,118 \times p^{(2 - 0,0008p)} \times \left(\frac{b_{i \text{ heavy}}}{b_{i \text{ standard}}} \right)^{0,5}$$

where

b_i is the estimated inner plate thickness given by

$$\frac{(b_2 - b_1)}{2,11} \text{ mm};$$

b_2 is the maximum width over inner link, in millimetres (mm);

b_1 is the minimum width between inner plates, in millimetres (mm);

K_s is

- 134 N/mm² for chains up to and including 160H and 160HE;
- 139 N/mm² for chains 180H and 180HE and above;

p is the chain pitch, in millimetres (mm).

NOTE Constant K_s is increased from 134 N/mm² to 139 N/mm² to allow for the reduction in the test specimen length from 5 free pitches to 3 free pitches when conducting the dynamic strength test.

C.3 “B” series chain

$$F_d = K_s \times A_i \times p^{(-0,000\ 9p)}$$

where

A_i is the sectional area of inner plate, given by

$$2b_i \times (0,99h_2 - d_b) \text{ mm}^2;$$

b_i is the estimated inner plate thickness, given by

$$\frac{(b_2 - b_1)}{2,11} \text{ mm};$$

d_b is the estimated bush diameter, given by

$$d_2 \times \left(\frac{d_1}{d_2} \right)^{0,475} \text{ mm};$$

b_2 is the maximum width over the inner link, in millimetres (mm);

b_1 is the minimum width between the inner plates, in millimetres (mm);

d_2 is the maximum pin diameter, in millimetres (mm);

d_1 is the maximum roller diameter, in millimetres (mm);

h_2 is the maximum inner plate depth, in millimetres (mm);

K_s is

— 134 N/mm² for chains up to and including 32B;

— 139 N/mm² for chains 40B and above;

p is the chain pitch, in millimetres (mm).

NOTE Constant K_s is increased from 134 N/mm² to 139 N/mm² to allow for the reduction in the test specimen length from 5 free pitches to 3 free pitches when conducting the dynamic strength test.

Annex D (informative)

Method of determining maximum test force F_{\max} when conducting dynamic strength conformance test

D.1 General

The maximum test force F_{\max} is given by

$$F_{\max} = \frac{F_d F_u + [F_{\min}(F_u - F_d)]}{F_u}$$

where

- F_{\max} is the maximum test force, in newtons (N);
- F_d is the minimum dynamic strength as given in [Table 1](#) or [Table 2](#), in newtons (N);
- F_u is the minimum tensile strength as given in [Table 1](#) or [Table 2](#), in newtons (N);
- F_{\min} is the minimum test force, in newtons (N).

D.2 Example for Chain 16B

If the chain manufacturer were to choose a minimum test force (F_{\min}) of 2 700 N (i.e. 4,5 % of the minimum tensile strength according to [Table 1](#)). Then, the maximum test force F_{\max} would be determined as follows:

$$F_{\max} = \frac{F_d F_u + [F_{\min}(F_u - F_d)]}{F_u}$$

and from [Table 1](#)

- $F_d = 9\,530$ N,
- $F_u = 60\,000$ N, and
- $F_{\min} = 2\,700$ N,

then

$$F_{\max} = \frac{(9\,530 \times 60\,000) + [2\,700 \times (60\,000 - 9\,530)]}{60\,000} = 11\,800 \text{ N.}$$

Annex E (informative)

Examples of methods used to avoid an excessive increase in the rate of stress during the tensile test

E.1 Introduction

While the following alternative methods are not universally accepted, they both give an indication as to the rate of loading during the tensile test that could be used to avoid an excessive rate of stress being incurred by the chain.

Please note that as these methods are only intended to be used as a guide and as such do not constitute a mandatory requirement of ISO 606.

E.2 Method 1 (Specified in ASME B29.1)

The tensile force is slowly applied at a rate not to exceed 50.8mm/min (2.0 in/min), in a uniaxial direction, to the ends of the chain sample.

E.3 Method 2 (Based on and conforming to ISO 6892-1:2009)

E.3.1 Procedure

The tensile force is slowly applied at a rate between 2 % $F_{u \text{ min}} / \text{s}$ and 4 % $F_{u \text{ min}} / \text{s}$, in a uniaxial direction, to the ends of the chain sample.

Using this method the typical length of time during which the chain is subjected to a tensile load would be between 25 s minimum and 50 s maximum.

This method is based on the recommended rate of stress increase as outlined in ISO 6892-1:2009 for conducting a tensile test.

For information, the above rates of testing in Method 2 were established as follows:

According to ISO 6892-1:2009 Para 10.4 Speed of tensile test a recommendation for the rate of stress increase is given in relation to Young's modulus E and is shown in [Table E.1](#).

Table E.1 — Rate of stress increase

Young's modulus E [MPa]	Rate of stress increase \dot{R} [MPa · s ⁻¹]
< 150 000	2 - 20
≥ 150 000	6- 60

The inner plate stress for chain 08B-1 would therefore be calculated as follows:

$b_1 = 7,75 \text{ mm}$	min width between inner plates
$b_2 = 11,30 \text{ mm}$	max width over inner link
$d_1 = 8,51 \text{ mm}$	max roller diameter
$d_2 = 4,45 \text{ mm}$	max pin diameter
$h_2 = 11,81 \text{ mm}$	max inner plate depth
$b_i = (b_2 - b_1) / 2, 11 = 1,68 \text{ mm}$	calculated inner plate thickness
$d_b = d_2 (d_1 / d_2)^{0,475} = 6,05 \text{ mm}$	calculated bush diameter
$S_{oIP} = (h_2 - d_b) b_i = 9,68 \text{ mm}^2$	inner plate cross section (one IP)
$F_u = 17\,800 \text{ N}$	minimum tensile strength
$(dF/dt)_{\min} = R_{\min} \cdot S_{oIP} \cdot 2$	rate of force
$(dF/dt)_{\min} = 6 \text{ [MPa / s]} \cdot S_{oIP} \cdot 2$	
$(dF/dt)_{\min} = 6 \text{ [N / (s} \cdot \text{mm}^2)] \cdot 9,68 \text{ mm}^2 \cdot 2 = 116 \text{ N / s}$	
$(dF/dt)_{\max} = \dot{R}_{\max} \cdot S_{oIP} \cdot 2$	
$(dF/dt)_{\max} = 60 \text{ [MPa / s]} \cdot S_{oIP} \cdot 2$	
$(dF/dt)_{\max} = 60 \text{ [N / (s} \cdot \text{mm}^2)] \cdot 9,68 \text{ mm}^2 \cdot 2 = 1,162 \text{ N / s}$	

E.3.2 Calculation of time

The calculation of time for the tensile test would be as follows:

$$T_{\min} = F_u / (dF/dt)_{\max} \quad \text{min time}$$

$$T_{\min} = 17\,800 \text{ N} / 1\,162 \text{ N / s}$$

$$T_{\min} = 15,3 \text{ s}$$

$$T_{\max} = F_u / (dF/dt)_{\min} \quad \text{max time}$$

$$T_{\max} = 17\,800 \text{ N} / 116 \text{ N / s}$$

$$T_{\max} = 153 \text{ s}$$

Now method 2 states: Speed of tensile test to be between 2 % $F_{u \min} / \text{s}$ and 4 % $F_{u \min} / \text{s}$, which would be:

$$T_{\max} = 17\,800 \text{ N} / 356 \text{ N / s} = 50 \text{ s}$$

$$T_{\min} = 17\,800 \text{ N} / 712 \text{ N / s} = 25 \text{ s}$$

Both T_{\min} and T_{\max} are within the ISO 6892-1 specification requirements of 15,3 s and 153 s.

E.3.3 Procedure using older tensile test equipment

For older tensile test equipment when only certain fixtures speed v_c [mm / min] can be set, the following procedure should be followed.

The fixture speed or the crosshead separation rate v_c [mm / min] is set such that the total testing time falls between $T_{\min} = 25$ and $T_{\max} = 50$ s.

A recommended starting point for the crosshead separation rate is

$$v_c = 10 \text{ [mm / min]}$$

A testing time over 50 s is not critical and provides valid breaking load test results. If the total testing time is below 20 s ($T_{\min} - 20\%$) the measured breaking load is not valid and the test shall be repeated with a reduced crosshead separation rate.

Annex F (informative)

Methods used to approximate the minimum dynamic test values for multiplex chains

Currently there is insufficient test data available to give an exact relationship between dynamic values of simplex chains to that of multiplex chains and as such there is no universally agreed method for calculating this relationship. If approximate minimum dynamic strength values are required for the duplex and triplex chains then the methods described in [F.1](#) and [F.2](#) could be considered:

F.1 Method 1 (German origin)

Min. dynamic strength of duplex chain = $1,50 \times$ value of corresponding simplex chain.

Min. dynamic strength of triplex chain = $1,92 \times$ value of corresponding simplex chain.

Except for the chains shown in [Table F.1](#).

Table F.1 — Factors for multiplex chains

Chain	Duplex/simplex	Triplex/simplex
06B	1,31	1,57
08B	1,33	1,62
10B	1,48	1,87
16B	1,47	1,90
20B	1,48	1,90

F.2 Method 2 (US origin)

For all chain pitches, the multiplex chain would be expected to have a chain strand factor of 0,67, which would then give:

- min. dynamic strength of duplex chain = $1,34 \times$ value of corresponding simplex chain;
- min. dynamic strength of triplex chain = $2,01 \times$ value of corresponding simplex chain.

The 0,67 strand factor requires that loose-fit intermediate plates have at least 80 % of the dynamic strength of the press-fit outer plates.

NOTE Before applying any chain loadings, which are obtained from the use of either of the above two alternative methods, obtain the advice of the chain manufacturer.

Bibliography

- [1] ISO 9633:2001, *Cycle chains — Characteristics and test methods*
- [2] ISO 10190:2008, *Motorcycle chains — Characteristics and test methods*
- [3] ISO 10823:2004, *Guidelines for the selection of roller chain drives*
- [4] ISO 6892-1:2009, *Metallic materials — Tensile testing — Part 1: Method of test at room temperature*
- [5] ISO 13203:2005, *Chains, sprockets and accessories — List of equivalent terms*

British Standards Institution (BSI)

BSI is the national body responsible for preparing British Standards and other standards-related publications, information and services.

BSI is incorporated by Royal Charter. British Standards and other standardization products are published by BSI Standards Limited.

About us

We bring together business, industry, government, consumers, innovators and others to shape their combined experience and expertise into standards-based solutions.

The knowledge embodied in our standards has been carefully assembled in a dependable format and refined through our open consultation process. Organizations of all sizes and across all sectors choose standards to help them achieve their goals.

Information on standards

We can provide you with the knowledge that your organization needs to succeed. Find out more about British Standards by visiting our website at bsigroup.com/standards or contacting our Customer Services team or Knowledge Centre.

Buying standards

You can buy and download PDF versions of BSI publications, including British and adopted European and international standards, through our website at bsigroup.com/shop, where hard copies can also be purchased.

If you need international and foreign standards from other Standards Development Organizations, hard copies can be ordered from our Customer Services team.

Subscriptions

Our range of subscription services are designed to make using standards easier for you. For further information on our subscription products go to bsigroup.com/subscriptions.

With **British Standards Online (BSOL)** you'll have instant access to over 55,000 British and adopted European and international standards from your desktop. It's available 24/7 and is refreshed daily so you'll always be up to date.

You can keep in touch with standards developments and receive substantial discounts on the purchase price of standards, both in single copy and subscription format, by becoming a **BSI Subscribing Member**.

PLUS is an updating service exclusive to BSI Subscribing Members. You will automatically receive the latest hard copy of your standards when they're revised or replaced.

To find out more about becoming a BSI Subscribing Member and the benefits of membership, please visit bsigroup.com/shop.

With a **Multi-User Network Licence (MUNL)** you are able to host standards publications on your intranet. Licences can cover as few or as many users as you wish. With updates supplied as soon as they're available, you can be sure your documentation is current. For further information, email bsmusales@bsigroup.com.

BSI Group Headquarters

389 Chiswick High Road London W4 4AL UK

Revisions

Our British Standards and other publications are updated by amendment or revision.

We continually improve the quality of our products and services to benefit your business. If you find an inaccuracy or ambiguity within a British Standard or other BSI publication please inform the Knowledge Centre.

Copyright

All the data, software and documentation set out in all British Standards and other BSI publications are the property of and copyrighted by BSI, or some person or entity that owns copyright in the information used (such as the international standardization bodies) and has formally licensed such information to BSI for commercial publication and use. Except as permitted under the Copyright, Designs and Patents Act 1988 no extract may be reproduced, stored in a retrieval system or transmitted in any form or by any means – electronic, photocopying, recording or otherwise – without prior written permission from BSI. Details and advice can be obtained from the Copyright & Licensing Department.

Useful Contacts:

Customer Services

Tel: +44 845 086 9001

Email (orders): orders@bsigroup.com

Email (enquiries): cservices@bsigroup.com

Subscriptions

Tel: +44 845 086 9001

Email: subscriptions@bsigroup.com

Knowledge Centre

Tel: +44 20 8996 7004

Email: knowledgecentre@bsigroup.com

Copyright & Licensing

Tel: +44 20 8996 7070

Email: copyright@bsigroup.com



...making excellence a habit.™