

Bonded abrasive products — Dimensions —

Part 11: Hand finishing sticks

ICS 25.100.70

National foreword

This British Standard reproduces verbatim ISO 603-11:1999 and implements it as the UK national standard.

The UK participation in its preparation was entrusted to Technical Committee MTE/13, Grinding wheels, abrasive tools, paper, cloths and powder, which has the responsibility to:

- aid enquirers to understand the text;
- present to the responsible international/European committee any enquiries on the interpretation, or proposals for change, and keep the UK interests informed;
- monitor related international and European developments and promulgate them in the UK.

A list of organizations represented on this committee can be obtained on request to its secretary.

Cross-references

The British Standards which implement international publications referred to in this document may be found in the BSI Standards Catalogue under the section entitled "International Standards Correspondence Index", or by using the "Find" facility of the BSI Standards Electronic Catalogue.

A British Standard does not purport to include all the necessary provisions of a contract. Users of British Standards are responsible for their correct application.

Compliance with a British Standard does not of itself confer immunity from legal obligations.

Summary of pages

This document comprises a front cover, an inside front cover, the ISO title page, pages ii and iii, a blank page, pages 1 to 4, an inside back cover and a back cover.

The BSI copyright notice displayed in this document indicates when the document was last issued.

Amendments issued since publication

| Amd. No. | Date | Comments |
|----------|------|----------|
| | | |
| | | |
| | | |
| | | |
| | | |

This British Standard, having been prepared under the direction of the Engineering Sector Committee, was published under the authority of the Standards Committee and comes into effect on 15 November 1999

© BSI 11-1999

INTERNATIONAL STANDARD

**ISO
603-11**

First edition
1999-07-15

Bonded abrasive products — Dimensions —

Part 11: Hand finishing sticks

Produits abrasifs agglomérés — Dimensions —

Partie 11: Pierres à main



Reference number
ISO 603-11:1999(E)

Foreword

ISO (the International Organization for Standardization) is a worldwide federation of national standards bodies (ISO member bodies). The work of preparing International Standards is normally carried out through ISO technical committees. Each member body interested in a subject for which a technical committee has been established has the right to be represented on that committee. International organizations, governmental and non-governmental, in liaison with ISO, also take part in the work. ISO collaborates closely with the International Electrotechnical Commission (IEC) on all matters of electrotechnical standardization.

International Standards are drafted in accordance with the rules given in the ISO/IEC Directives, Part 3.

Draft International Standards adopted by the technical committees are circulated to the member bodies for voting. Publication as an International Standard requires approval by at least 75 % of the member bodies casting a vote.

International Standard ISO 603-11 was prepared by Technical Committee ISO/TC 29, *Small tools*, subcommittee SC 5, *Grinding wheels and abrasives*.

This first edition, together with ISO 603-1:1999 to ISO 603-10:1999 and ISO 603-12:1999 to ISO 603-16:1999, cancels and replaces ISO/R 603:1967, ISO 603-2:1981, ISO 1117:1975, ISO 2220:1972, ISO 2933:1974, ISO 3290:1976 and ISO 3921:1976 as a technical revision of these standards.

ISO 603 consists of the following parts, under the general title *Bonded abrasive products — Dimensions*:

- *Part 1: Grinding wheels for external cylindrical grinding between centres*
- *Part 2: Grinding wheels for centreless external cylindrical grinding*
- *Part 3: Grinding wheels for internal cylindrical grinding*
- *Part 4: Grinding wheels for surface grinding/peripheral grinding*
- *Part 5: Grinding wheels for surface grinding/face grinding*
- *Part 6: Grinding wheels for tool and tool room grinding*
- *Part 7: Grinding wheels for manually guided grinding*
- *Part 8: Grinding wheels for deburring and fettling/snagging*
- *Part 9: Grinding wheels for high-pressure grinding*
- *Part 10: Stones for honing and superfinishings*
- *Part 11: Hand finishing sticks*
- *Part 12: Grinding wheels for deburring and fettling on a straight grinder*

- *Part 13: Grinding wheels for deburring and fettling on a vertical grinder*
- *Part 14: Grinding wheels for deburring and fettling/snagging on an angle grinder*
- *Part 15: Grinding wheels for cutting-off on stationary or mobile cutting-off machines*
- *Part 16: Grinding wheels for cutting-off on hand held power tools*

Bonded abrasive products — Dimensions —

Part 11: Hand finishing sticks

1 Scope

This part of ISO 603 specifies the nominal dimensions, in millimeters, of:

- Type 90: Hand finishing sticks

These bonded abrasive products are intended to be used for the generation and sharpening of any tool surface. The workpiece is held in the hand and the finishing stick is guided by hand.

2 Normative reference

The following normative document contains provisions which, through reference in this text, constitute provisions of this part of ISO 603. For dated references, subsequent amendments to, or revisions of, any of these publications do not apply. However, parties to agreements based on this part of ISO 603 are encouraged to investigate the possibility of applying the most recent edition of the normative document indicated below. For undated references, the latest edition of the normative document referred to applies. Members of ISO and IEC maintain registers of currently valid International Standards.

ISO 525:1999, *Bonded abrasive products — General requirements*.

3 Dimensions

See Table 1.

Table 1 — Dimensions of Type 9010, Type 9011, Type 9020, Type 9030 and Type 9040

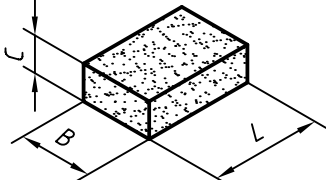
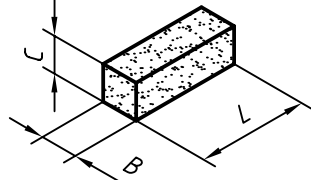
| Type 9010 | | | Type 9011 | |
|---|----------|----------|--|----------|
|  | | |  | |
| <i>B</i> | <i>C</i> | <i>L</i> | <i>B = C</i> | <i>L</i> |
| 6 | 3 | 100 | 6 | 100 |
| 10 | 5 | | 10 | — |
| 13 | 6 | | — | — |
| 25 | 13 | 150 | — | 150 |
| 16 | 8 | | 13 | |
| 15 | 10 | | 16 | |
| 20 | 10 | 200 | 20 | 150 |
| 50 | 25 | | 25 | |
| 20 | 15 | | 20 | 200 |
| 30 | 20 | 200 | — | — |
| 50 | 25 | | — | — |

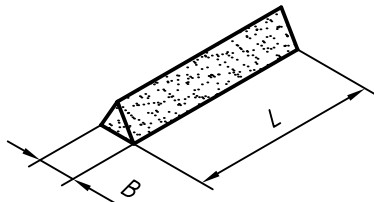
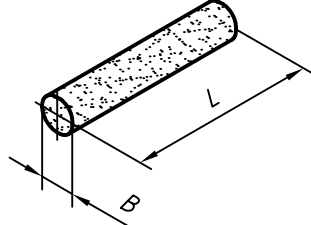
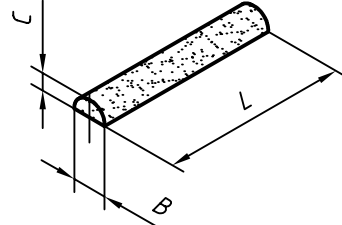
| Type 9020 | | Type 9030 | | Type 9040 | |
|---|----------|---|----------|--|----------|
|  | |  | |  | |
| <i>B</i> | <i>L</i> | <i>B</i> | <i>L</i> | <i>B = 2C</i> | <i>L</i> |
| 6 | 100 | 6 | 100 | 6 | 100 |
| 8 | | 8 | | | |
| 10 | | 10 | | | |
| 13 | 150 | 10 | 150 | 10 | 150 |
| 10 | | 13 | | | |
| 13 | | 16 | | | |
| 16 | 200 | 20 | 200 | 20 | 200 |
| 20 | | 25 | 250 | 25 | 250 |
| 25 | 250 | — | — | — | — |
| 30 | | — | — | — | — |

4 Designation

A complete designation of a bonded abrasive product in accordance with this part of ISO 603 shall be consist of the following information:

- a) designation of the bonded abrasives, e.g. "Hand finishing stick";
- b) reference of this part of ISO 603;
- c) type (shape);
- d) dimensions;
- e) specifications of an internal nature;

} In accordance with ISO 525
and this part of ISO 603

EXAMPLE

A hand finishing stick for the generation of any tool surface, Type 9020, $B = 13$ mm, $L = 100$ mm, nature of abrasive C, grain size 150, bond V is designated as follows:

Hand finishing stick ISO 603-11 - 9020 - 13 × 100 - C 150V

5 Specifications

The specifications are left to the manufacture's discretion, see ISO 525.

5.1 Marking

Marking of bonded abrasive products is in accordance with ISO 525.

Bibliography

- [1] ISO 8486-1, *Bonded abrasives — Determination and designation of grain size distribution — Part 1: Macrogrits F4 to F220.*
- [2] ISO 8486-2, *Bonded abrasives — Determination and designation of grain size distribution — Part 2: Microgrits F230 to F1200.*

BSI — British Standards Institution

BSI is the independent national body responsible for preparing British Standards. It presents the UK view on standards in Europe and at the international level. It is incorporated by Royal Charter.

Revisions

British Standards are updated by amendment or revision. Users of British Standards should make sure that they possess the latest amendments or editions.

It is the constant aim of BSI to improve the quality of our products and services. We would be grateful if anyone finding an inaccuracy or ambiguity while using this British Standard would inform the Secretary of the technical committee responsible, the identity of which can be found on the inside front cover. Tel: 020 8996 9000. Fax: 020 8996 7400.

BSI offers members an individual updating service called PLUS which ensures that subscribers automatically receive the latest editions of standards.

Buying standards

Orders for all BSI, international and foreign standards publications should be addressed to Customer Services. Tel: 020 8996 9001. Fax: 020 8996 7001.

In response to orders for international standards, it is BSI policy to supply the BSI implementation of those that have been published as British Standards, unless otherwise requested.

Information on standards

BSI provides a wide range of information on national, European and international standards through its Library and its Technical Help to Exporters Service. Various BSI electronic information services are also available which give details on all its products and services. Contact the Information Centre. Tel: 020 8996 7111. Fax: 020 8996 7048.

Subscribing members of BSI are kept up to date with standards developments and receive substantial discounts on the purchase price of standards. For details of these and other benefits contact Membership Administration. Tel: 020 8996 7002. Fax: 020 8996 7001.

Copyright

Copyright subsists in all BSI publications. BSI also holds the copyright, in the UK, of the publications of the international standardization bodies. Except as permitted under the Copyright, Designs and Patents Act 1988 no extract may be reproduced, stored in a retrieval system or transmitted in any form or by any means – electronic, photocopying, recording or otherwise – without prior written permission from BSI.

This does not preclude the free use, in the course of implementing the standard, of necessary details such as symbols, and size, type or grade designations. If these details are to be used for any other purpose than implementation then the prior written permission of BSI must be obtained.

If permission is granted, the terms may include royalty payments or a licensing agreement. Details and advice can be obtained from the Copyright Manager. Tel: 020 8996 7070.