



BSI Standards Publication

Test code for machine tools

Part 1: Geometric accuracy of machines operating under no-load or quasi-static conditions

NO COPYING WITHOUT BSI PERMISSION EXCEPT AS PERMITTED BY COPYRIGHT LAW

National foreword

This British Standard is the UK implementation of ISO 230-1:2012. It supersedes BS ISO 230-1:1996 which is withdrawn.

The UK participation in its preparation was entrusted by Technical Committee MTE/1, Machine tools, to Subcommittee MTE/1/2, Machine tools - Accuracy.

A list of organizations represented on this committee can be obtained on request to its secretary.

This publication does not purport to include all the necessary provisions of a contract. Users are responsible for its correct application.

© The British Standards Institution 2012

Published by BSI Standards Limited 2012

ISBN 978 0 580 54575 7

ICS 25.080.01

Compliance with a British Standard cannot confer immunity from legal obligations.

This British Standard was published under the authority of the Standards Policy and Strategy Committee on 31 March 2012.

Amendments issued since publication

Amd. No.	Date	Text affected
----------	------	---------------

INTERNATIONAL STANDARD

ISO
230-1

Third edition
2012-03-01

Test code for machine tools —

Part 1:

Geometric accuracy of machines operating under no-load or quasi-static conditions

Code d'essai des machines-outils —

*Partie 1: Exactitude géométrique des machines fonctionnant à vide ou
dans des conditions quasi-statiques*



Reference number
ISO 230-1:2012(E)



COPYRIGHT PROTECTED DOCUMENT

© ISO 2012

All rights reserved. Unless otherwise specified, no part of this publication may be reproduced or utilized in any form or by any means, electronic or mechanical, including photocopying and microfilm, without permission in writing from either ISO at the address below or ISO's member body in the country of the requester.

ISO copyright office
Case postale 56 • CH-1211 Geneva 20
Tel. + 41 22 749 01 11
Fax + 41 22 749 09 47
E-mail copyright@iso.org
Web www.iso.org

Published in Switzerland

Contents

Page

Foreword	v
Introduction.....	vi
1 Scope	1
2 Normative references	1
3 Terms and definitions	2
3.1 General	2
3.2 Terms for machine coordinate system and motion nomenclature	2
3.3 Terms for static compliance and hysteresis	3
3.4 Terms for linear axes	4
3.5 Terms for axes of rotation	12
3.6 Terms for parallelism error and squareness error of axes of motion.....	19
3.7 Terms for other relationships between axis average lines	25
3.8 Terms for multi-axes motion or kinematic tests	26
3.9 Terms for geometric accuracy of machine functional surfaces, machine tool components and test pieces.....	30
4 Tolerances.....	34
4.1 General	34
4.2 Tolerances applicable to machine tool functional surfaces, machine tool components and test pieces	40
4.3 Additional limiting conditions associated with tolerances.....	40
5 Uncertainty of measurements, test methods and measuring instruments.....	41
6 Preliminary operations.....	42
6.1 Installation of the machine before tests.....	42
6.2 Conditions before machine tests.....	43
6.3 Test setup and instrumentation	44
7 Machine static compliance and hysteresis tests	45
7.1 General	45
7.2 Tests for machine static compliance and hysteresis by applying force externally	45
7.3 Tests for machine static compliance and hysteresis by applying force internally	47
7.4 Tests for machines with rotary axes	50
8 Geometric accuracy tests of axes of linear motion	52
8.1 General	52
8.2 Straightness error motion tests	53
8.3 Linear positioning error motion tests	58
8.4 Angular error motions tests	60
9 Geometric accuracy tests of axes of rotation	64
9.1 Reference to ISO 230-7	64
9.2 Angular positioning error motion	64
10 Alignment of axes of motion — Parallelism, squareness, coaxiality and intersection.....	67
10.1 Parallelism of axes of motion.....	67
10.2 Coaxiality error of axis average lines.....	73
10.3 Squareness error of axes of motion.....	76
10.4 Intersection of axis average lines.....	83
11 Multi-axes motion (kinematic) tests	85
11.1 General	85
11.2 Linear trajectories	86

11.3	Circular trajectories	87
11.4	Conical (shape) motion	94
11.5	Spherical interpolation test using spherical artefacts and linear displacement sensors.....	95
11.6	Flatness error of a surface generated by two axes of linear motion.....	96
11.7	Special tests	97
12	Geometric accuracy tests of machine functional surfaces — Straightness, flatness, perpendicularity and parallelism.....	100
12.1	Straightness error of machine functional surfaces	100
12.2	Flatness of machine tables	110
12.3	Position and orientation of functional surfaces	118
12.4	Squareness error and perpendicularity error between lines and planes	128
12.5	Run-out of rotational components.....	132
Annex A	(informative) Machine tool coordinate system and position and orientation errors	134
Annex B	(informative) Test piece measurement	147
Annex C	(informative) Cross-reference.....	149
Bibliography	158
Index	Alphabetical index of terms and definitions.....	159

Foreword

ISO (the International Organization for Standardization) is a worldwide federation of national standards bodies (ISO member bodies). The work of preparing International Standards is normally carried out through ISO technical committees. Each member body interested in a subject for which a technical committee has been established has the right to be represented on that committee. International organizations, governmental and non-governmental, in liaison with ISO, also take part in the work. ISO collaborates closely with the International Electrotechnical Commission (IEC) on all matters of electrotechnical standardization.

International Standards are drafted in accordance with the rules given in the ISO/IEC Directives, Part 2.

The main task of technical committees is to prepare International Standards. Draft International Standards adopted by the technical committees are circulated to the member bodies for voting. Publication as an International Standard requires approval by at least 75 % of the member bodies casting a vote.

Attention is drawn to the possibility that some of the elements of this document may be the subject of patent rights. ISO shall not be held responsible for identifying any or all such patent rights.

ISO 230-1 was prepared by Technical Committee ISO/TC 39, *Machine tools*, Subcommittee SC 2, *Test conditions for metal cutting machine tools*.

This third edition cancels and replaces the second edition (ISO 230-1:1996), which has been technically revised.

ISO 230 consists of the following parts, under the general title *Test code for machine tools*:

- *Part 1: Geometric accuracy of machines operating under no-load or quasi-static conditions*
- *Part 2: Determination of accuracy and repeatability of positioning of numerically controlled axes*
- *Part 3: Determination of thermal effects*
- *Part 4: Circular tests for numerically controlled machine tools*
- *Part 5: Determination of the noise emission*
- *Part 6: Determination of positioning accuracy on body and face diagonals (Diagonal displacement tests)*
- *Part 7: Geometric accuracy of axes of rotation*
- *Part 8: Vibrations [Technical Report]*
- *Part 9: Estimation of measurement uncertainty for machine tool tests according to series ISO 230, basic equations [Technical Report]*
- *Part 10: Determination of the measuring performance of probing systems of numerically controlled machine tools*

The following part is under preparation:

- *Part 11: Measuring instruments and their application to machine tool geometry tests [Technical Report].*

Introduction

ISO/TC 39/SC 2 decided to revise and restructure this part of ISO 230 for the following reasons:

- a) some subclauses of the previous edition overlapped with other newly specified test codes;
- b) for practical reasons, it was necessary to modify the definitions of parallelism error and squareness error in order to exclude straightness error when looking at machine tool motion;

NOTE These definitions are not intended to be used for describing parallelism and perpendicularity errors of components and features. For components and features, this part of ISO 230 directly complies with the parallelism error and perpendicularity error definitions derived from other International Standards (e.g. ISO 1101).

- c) a clear separation was desired among error motions of a trajectory and imperfections of functional surfaces and workpieces;
- d) there was a need to address advances in machine tool technologies, measurement methods and measurement instruments.
- e) Annex A of the second edition became wider, as new measuring methods/apparatus have been developed and introduced for higher accuracy and faster measurements. Therefore, it was separated from the main body to become a future Part 11 (Technical Report).
- f) furthermore, to align this part of ISO 230 with ISO 14253 (all parts), subclauses related to the uncertainty of measurement have been introduced.

Test code for machine tools —

Part 1:

Geometric accuracy of machines operating under no-load or quasi-static conditions

1 Scope

This part of ISO 230 specifies methods for testing the accuracy of machine tools, operating either under no-load or under quasi-static conditions, by means of geometric and machining tests. The methods can also be applied to other types of industrial machines.

This part of ISO 230 covers power-driven machines, which can be used for machining metal, wood, etc., by the removal of chips or swarf material or by plastic deformation. It does not cover power-driven portable hand tools.

This part of ISO 230 relates to the testing of geometric accuracy. It is not applicable to the operational testing of the machine tool (vibrations, stick-slip motion of components, etc.) or to the checking of characteristics (speeds, feeds).

This part of ISO 230 does not cover the geometric accuracy of high-speed machine motions where machining forces are typically smaller than acceleration forces.

2 Normative references

The following referenced documents are indispensable for the application of this document. For dated references, only the edition cited applies. For undated references, the latest edition of the referenced document (including any amendments) applies.

ISO 1, *Geometrical Product Specifications (GPS) — Standard reference temperature for geometrical product specification and verification*

ISO 230-2, *Test code for machine tools — Part 2: Determination of accuracy and repeatability of positioning of numerically controlled axes*

ISO 230-4, *Test code for machine tools — Part 4: Circular tests for numerically controlled machine tools*

ISO 230-6, *Test code for machine tools — Part 6: Determination of positioning accuracy on body and face diagonals (Diagonal displacement tests)*

ISO 230-7, *Test code for machine tools — Part 7: Geometric accuracy of axes of rotation*

ISO/TR 230-8, *Test code for machine tools — Part 8: Vibrations*

ISO 841, *Industrial automation systems and integration — Numerical control of machines — Coordinate system and motion nomenclature*

ISO 1101, *Geometrical Product Specifications (GPS) — Geometrical tolerancing — Tolerances of form, orientation, location and run-out*

ISO 12181-1:2011, *Geometrical product specifications (GPS) — Roundness — Part 1: Vocabulary and parameters of roundness*

ISO 12780-1:2011, *Geometrical product specifications (GPS) — Straightness — Part 1: Vocabulary and parameters of straightness*

ISO 12781-1:2011, *Geometrical product specifications (GPS) — Flatness — Part 1: Vocabulary and parameters of flatness*

ISO 14253-1, *Geometrical Product Specifications (GPS) — Inspection by measurement of workpieces and measuring equipment — Part 1: Decision rules for proving conformance or non-conformance with specifications*

3 Terms and definitions

3.1 General

For the purposes of this document, the terms and definitions given in ISO 230-2, ISO 230-4, ISO 230-7, ISO 841, ISO 12181-1, ISO 12780-1 and ISO 12781-1 and the following apply.

This part of ISO 230 uses metrological definitions, which take into account actual motions, real lines and surfaces accessible to measurement taking into account the limitations introduced by the construction or the practicality of geometric verification.

NOTE 1 In some cases, geometric definitions (definitions of run-out, etc.) have been retained in this part of ISO 230, in order to eliminate any confusion and to clarify the language used. However, when describing test methods, measuring instruments and tolerances, metrological definitions are taken as the basis.

NOTE 2 For the alphabetical list of terms and definitions, see the index.

3.2 Terms for machine coordinate system and motion nomenclature

3.2.1

machine coordinate system

right-hand rectangular system with the three principal axes labelled X, Y and Z, with rotary axes about each of these axes labelled A, B and C, respectively

See Figure 1.

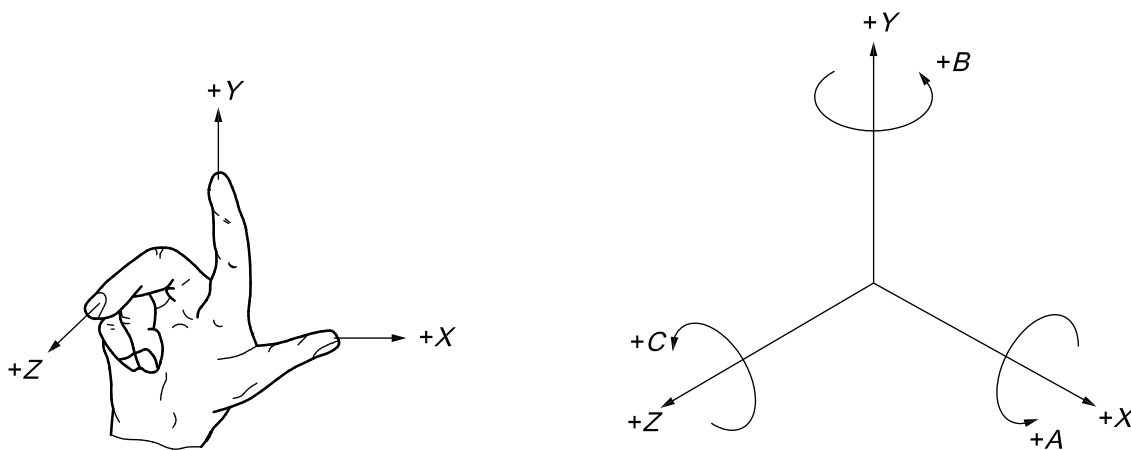

Figure 1 — Right-hand rectangular machine coordinate system

3.3 Terms for static compliance and hysteresis

3.3.1

structural loop

assembly of components, which maintains the relative position between two specified objects

[ISO 230-7:2006, definition 3.1.13]

NOTE A typical pair of specified objects is a cutting tool and a workpiece, in which case the structural loop includes the spindle, bearings and spindle housing, the machine head stock, the machine slideways and frame, and the fixtures for holding the tool and workpiece. For large machines, the foundation can also be part of the structural loop.

3.3.2

static compliance

linear (or angular) displacement per unit static force (or moment) between two objects, specified with respect to the structural loop, the location and direction of the applied forces, and the location and direction of the displacement of interest

NOTE 1 Static compliance is reciprocal to static stiffness. Static compliance is preferred because of its additive properties.

NOTE 2 The term “cross compliance” is used when displacement and force are not measured in the same direction.

3.3.3

play

condition of zero stiffness over a limited range of displacement due to clearance between the components of a structural loop

[ISO 230-7:2006, definition 3.1.21]

3.3.4

hysteresis

linear (or angular) displacement between two objects resulting from the sequential application and removal of equal forces (or moments) in opposite directions

[ISO 230-7:2006, definition 3.1.22]

3.3.5

setup hysteresis

hysteresis of the various components in a test setup, normally due to loose mechanical connections

[ISO 230-7:2006, definition 3.1.22.1]

3.3.6

machine hysteresis

hysteresis of the machine structure when subjected to specific loads

[ISO 230-7:2006, definition 3.1.22.2]

3.4 Terms for linear axes

3.4.1 General

In this part of ISO 230, many definitions and tests address errors in the relative motion between the component of the machine that carries the cutting tool and the component that carries the workpiece. These errors are defined and measured at the position or trajectory of the functional point.

3.4.2 functional point

cutting tool centre point or point associated with a component on the machine tool where cutting tool would contact the part for the purposes of material removal

See Figure 2.

NOTE 1 The functional point is a single point that can move within the machine tool working volume. This part of ISO 230 and related machine tool-specific standards, typically recommend to perform tests of geometrical characteristics applying test setups that are representative of the relative position between a (moving) tool of estimated average length and the hypothetical centre of a (moving) workpiece assumed to be located near the centre travel of the machine tool axes.

NOTE 2 To improve readability, definitions and tests of this part of ISO 230 use the expression: “functional point on a moving component” instead of the formally more accurate expression: “moving point representing the relative position between a (moving) tool and a (moving) workpiece”.

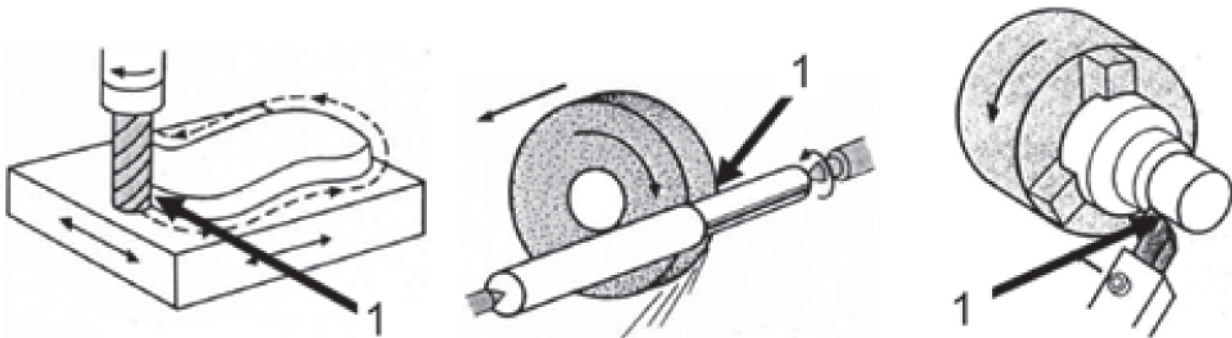

Key

1 functional point

Figure 2 — Examples of functional points

3.4.3 error motions of a linear axis

unwanted linear and angular motions of a component commanded to move along a (nominal) straight-line trajectory

See Figure 3.

NOTE 1 Error motions are identified by the letter *E* followed by a subscript, where the first letter is the name of the axis corresponding to the direction of the error motion and the second letter is the name of the axis of motion (see Figure 3 and Annex A).

NOTE 2 Linear error motions are defined in 3.4.4; angular error motions are defined in 3.4.16.

3.4.4 linear error motions of a linear axis

three translational error motions of the functional point of a moving component commanded to move along a (nominal) straight-line trajectory, the first one being along the direction of the (nominal) motion and the other two being along two directions orthogonal to this direction

NOTE 1 The linear error motion along the direction of motion is called **linear positioning error motion** (3.4.5). The other two translational error motions are called **straightness error motions** (3.4.8).

NOTE 2 The linear error motions measured at the functional point include the effects of angular error motions. The effects of these angular error motions are different when the location of a measurement point on the moving component is different from the functional point. In such cases, angular error motions are taken into account to determine the deviations of the trajectory of the functional point.

NOTE 3 If the moving component cannot be regarded as a rigid body, e.g. in the case of a large moving table, tests are carried out for more than one point on the moving component.

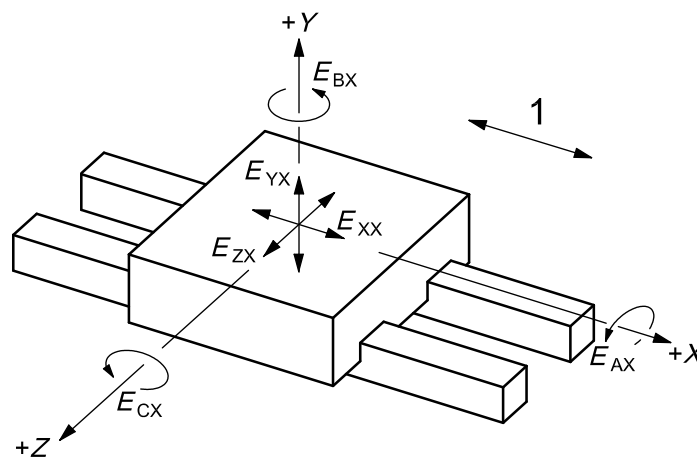

Key

- 1 X-axis commanded linear motion
- E_{AX} angular error motion around A-axis (roll)
- E_{BX} angular error motion around B-axis (yaw)
- E_{CX} angular error motion around C-axis (pitch)
- E_{XX} linear positioning error motion of X-axis; positioning deviations of X-axis
- E_{YX} straightness error motion in Y-axis direction
- E_{ZX} straightness error motion in Z-axis direction

Figure 3 — Angular and linear error motions of a component commanded to move along a (nominal) straight-line trajectory parallel to the X-axis

3.4.5 linear positioning error motion

unwanted motion along the direction of motion that results in the actual local position reached by the moving component at the functional point differing from the local commanded position along the direction of motion

See Figure 4.

NOTE 1 The positive sign of the positioning error motion is in the direction of the positive direction of the motion (according to ISO 841).

NOTE 2 Linear positioning error motion is associated with imperfections of the moving component and its guiding system. It is not associated with the dynamic response of the moving component and its positioning servo control system.

3.4.6
linear positioning deviation

position reached by the functional point on the moving component minus the target position

NOTE 1 Adapted from ISO 230-2:2006, definition 2.5.

NOTE 2 Positioning deviations are measured at specified discrete intervals in accordance with the requirements of ISO 230-2, to determine positioning accuracy and repeatability of numerically controlled axes.

NOTE 3 Positioning deviations, measured in accordance with the requirements of ISO 230-2, constitute a limited representation of positioning error motion (see Figure 4).

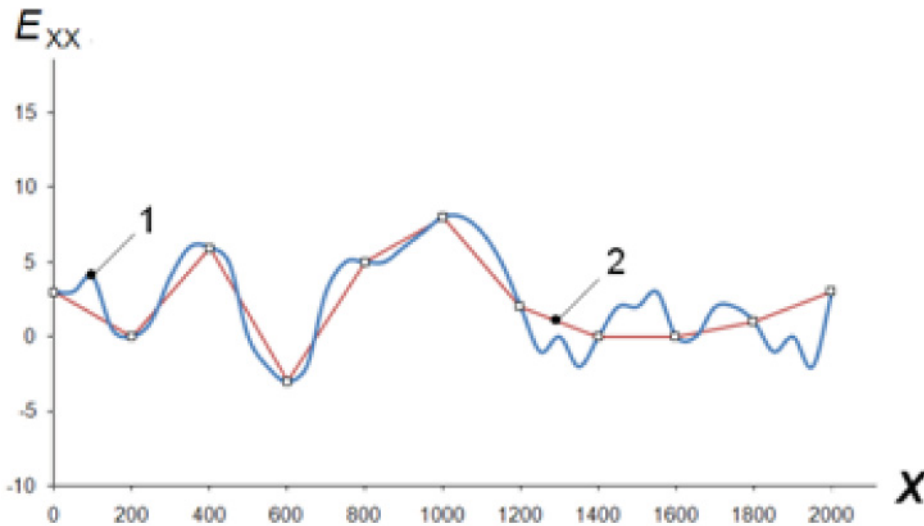

Key

- X X-axis coordinates (mm)
- E_{XX} X-axis positioning deviation and positioning error motion (μm)
- 1 plot of the actual positioning error motion of the X-axis
- 2 plot of the measured positioning deviations of the X-axis

Figure 4 — Example of linear positioning error motion and measured linear positioning deviations of the linear motion of a functional point along the X-axis

3.4.7
linear positioning error
linear positioning accuracy
accuracy of linear positioning

value of the largest positive linear positioning deviation added to the absolute value of the largest negative positioning deviation, evaluated in accordance with specified conventions

NOTE 1 This definition only applies to axes that are not continuously numerically controlled. Accuracy of linear positioning of continuous numerically controlled axes is established and determined in accordance with the requirements of ISO 230-2.

NOTE 2 A convention for linear positioning error evaluation can be to position a linear axis manually over 100 mm, ten times forward, ten times backward and evaluate for each positioning the linear positioning deviation.

3.4.8
straightness error motion

unwanted motion in one of the two directions orthogonal to the direction of a linear axis commanded to move along a (nominal) straight-line trajectory

See Figures 5 and 6.

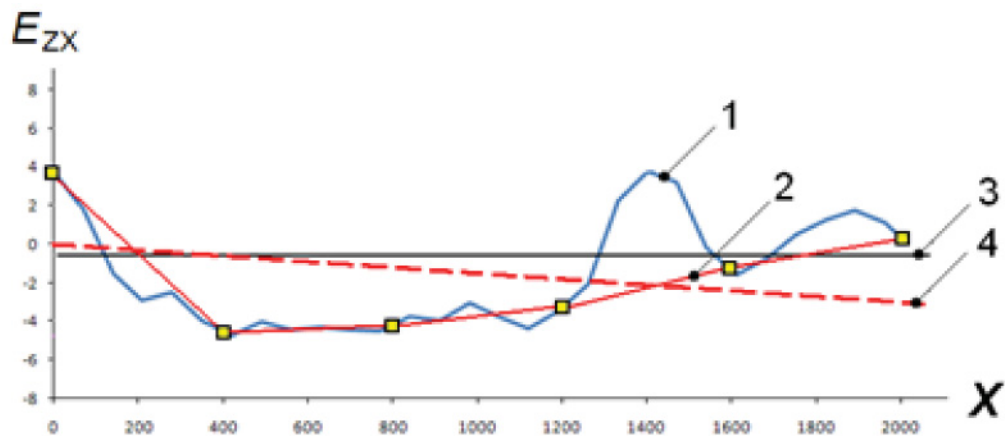

Key

- X X-axis coordinates (mm)
- E_{ZX} straightness deviations of X in Z-axis direction (μm)
- 1 plot of the actual linear error motion of X in Z-axis direction
- 2 plot of the measured straightness error motion
- 3 mean minimum zone reference straight line associated with actual linear error motion
- 4 mean minimum zone reference straight line associated with measured straightness error motion

Figure 5 — Example of straightness error motion in Z-direction and measured straightness error motion of the functional point trajectory for X-axis motion

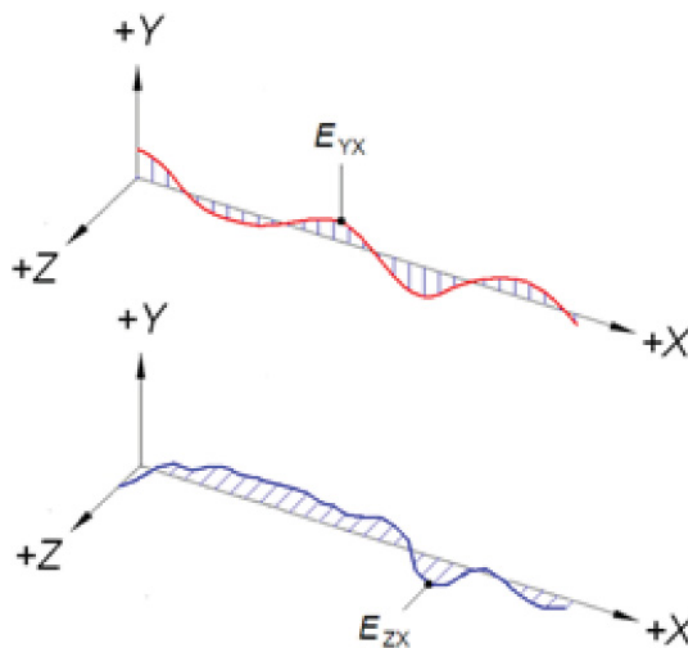

Key

- E_{YX} straightness deviations of X in Y-axis direction
- E_{ZX} straightness deviations of X in Z-axis direction

Figure 6 — Representation of straightness deviations of X-axis in Y- and Z-axis direction

3.4.9 straightness deviation

distance of the functional point from the **reference straight line** (3.4.12) fitting its trajectory, measured in one of the two directions orthogonal to the direction of a commanded (nominal) straight-line trajectory

See Figure 6.

NOTE 1 Straightness deviations are measured at low speed (or when the axis under test has stopped) in order to avoid dynamic cross-talk.

NOTE 2 Straightness deviations, measured at discrete intervals (400 mm in the example of Figure 5), constitute a limited representation of the actual straightness error motion.

NOTE 3 The positive sign of the straightness deviation is in the positive direction of the associated principal axis according to ISO 841.

3.4.10 straightness error of a linear axis

value of the largest positive straightness deviation added to the absolute value of the largest negative straightness deviation (with respect to any previously defined reference straight line)

NOTE The minimum straightness error is obtained by using the minimum zone reference straight line.

3.4.11 straightness property of a straight line

[ISO 12780-1:2011, definition 3.1.1]

NOTE The actual trajectory of the functional point of a moving component, commanded to move along a nominal straight-line trajectory, is not a straight line.

3.4.12 reference straight line

general direction of the line
associated straight line fitting the measured trajectory of a functional point in accordance with specified conventions, to which the straightness deviations and the straightness error are referred

NOTE 1 The reference straight line is computed from the measured deviations in two orthogonal planes (see Figure 6), within the boundary of the measurement being performed.

NOTE 2 The previous edition of this part of ISO 230 used the expressions “representative line”; it is a non-preferred expression for “reference straight line”.

NOTE 3 The mean minimum zone **reference straight line** (3.4.13), or the **least squares reference straight line** (3.4.14), or the **end-point reference straight line** (3.4.15) can be used (see Figures 7, 8 and 9).

NOTE 4 The minimum straightness error is typically evaluated by using the mean minimum zone reference straight line. However, since software for minimum zone calculation has limited availability, straightness error is evaluated as the minimum error resulting from using the least squares reference straight line or using the end-point reference straight line.

3.4.13 mean minimum zone reference straight line

arithmetic mean of two parallel straight lines in the straightness plane enclosing the measured straightness deviations and having the least separation

See Figure 7.

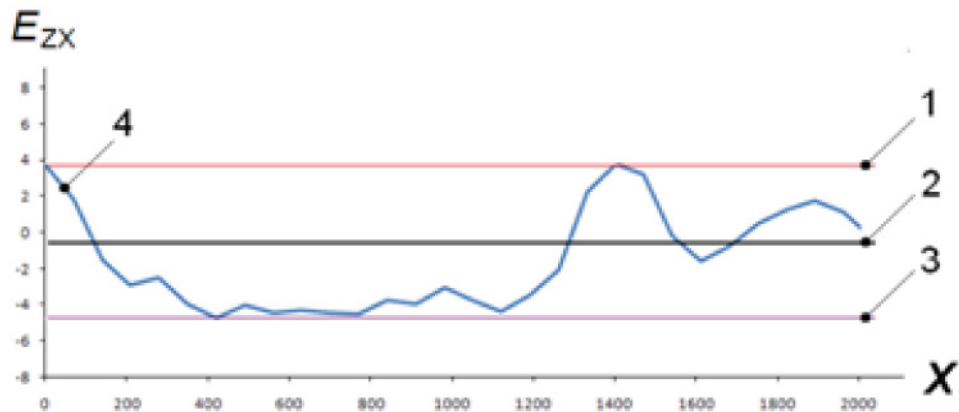

Key

- X X-axis coordinates (mm)
- E_{ZX} straightness deviations of X in Z-axis direction (μm)
- 1 upper minimum zone reference straight line at positive E_{ZX}
- 2 mean minimum zone reference straight line
- 3 lower minimum zone reference straight line at negative E_{ZX}
- 4 measured straightness deviations

Figure 7 — Example of minimum zone reference straight lines for straightness of X in the ZX plane

3.4.14

least squares reference straight line

straight line, where the sum of the squares of the measured straightness deviations is minimum

See Figure 8.

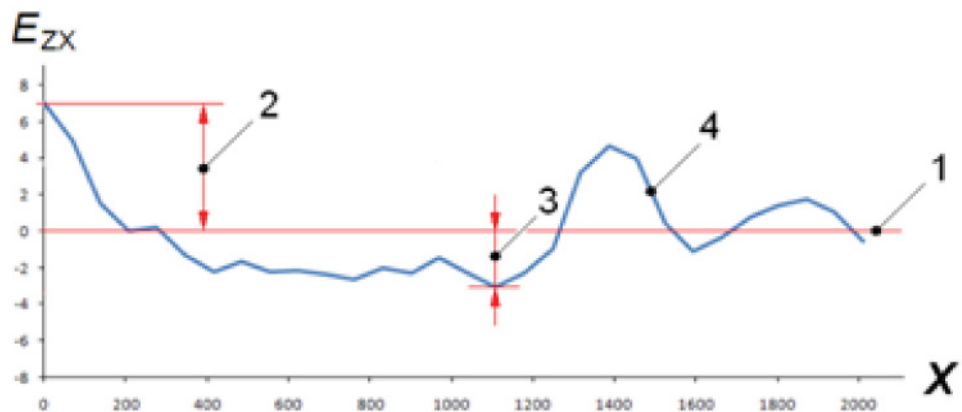

Key

- X X-axis coordinates (mm)
- E_{ZX} straightness deviations of X in Z-axis direction (μm)
- 1 least squares reference straight line
- 2 largest positive straightness deviation E_{ZX}
- 3 largest negative straightness deviation E_{ZX}
- 4 measured straightness deviations

Figure 8 — Example of least squares reference straight line for straightness of X in ZX plane

3.4.15
end-point reference straight line

straight line connecting the first and the last point of the measured straightness deviations

See Figure 9.

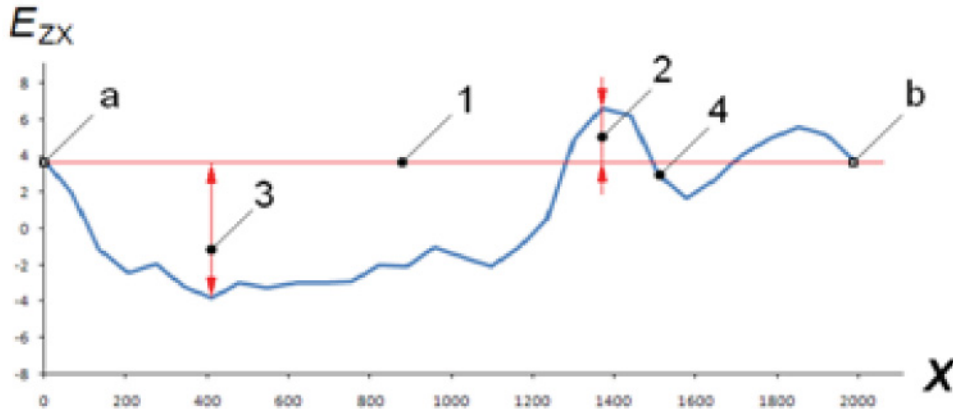

Key

- X X-axis coordinates (mm)
- E_{ZX} straightness deviations of X in Z-axis direction (μm)
- 1 end-point reference straight line
- 2 largest positive straightness deviation E_{ZX}
- 3 largest negative straightness deviation E_{ZX}
- 4 measured straightness deviations
- a First measurement point.
- b Last measurement point.

Figure 9 — Example of end-point reference straight line for straightness of X in ZX plane

3.4.16
angular error motions of a linear axis

three unwanted rotational movements of a moving component commanded to move along a (nominal) straight-line trajectory

NOTE 1 The positive sign of the angular error motions follows the right-hand rule described in ISO 841 (see Figure 3).

NOTE 2 There are three rotations around the three orthogonal directions: one around the axis of motion and one around each of the two axes square to the axis of motion (see Figure 3). The rotation around the moving direction can be called roll. The rotations around axes, which are perpendicular to the moving direction, are called tilt. There are two tilts. For a horizontally moving axis, tilt around the vertical axis can be called yaw, tilt around the horizontal axis can be called pitch.

NOTE 3 The linear error motions of the functional point include the effects of angular error motions. The effects of these angular error motions are different when the location of a measurement point on the moving component is different from the functional point (see Figure 10). In such cases, angular error motions are taken into account to estimate the deviations of the trajectory of the functional point (see Figure 10).

NOTE 4 The terms “pitch” and “yaw” are used for horizontal axes only. These terms are not relevant to vertical axes.

3.4.17
angular deviation

reading of an angular measuring instrument in the direction around any of the three orthogonal directions, measured during a complete traverse of the moving component

3.4.18
angular error of a linear axis

value of the largest positive angular deviation added to the absolute value of the largest negative angular deviation measured during a complete traverse of the moving component, evaluated in each one of the three orthogonal directions

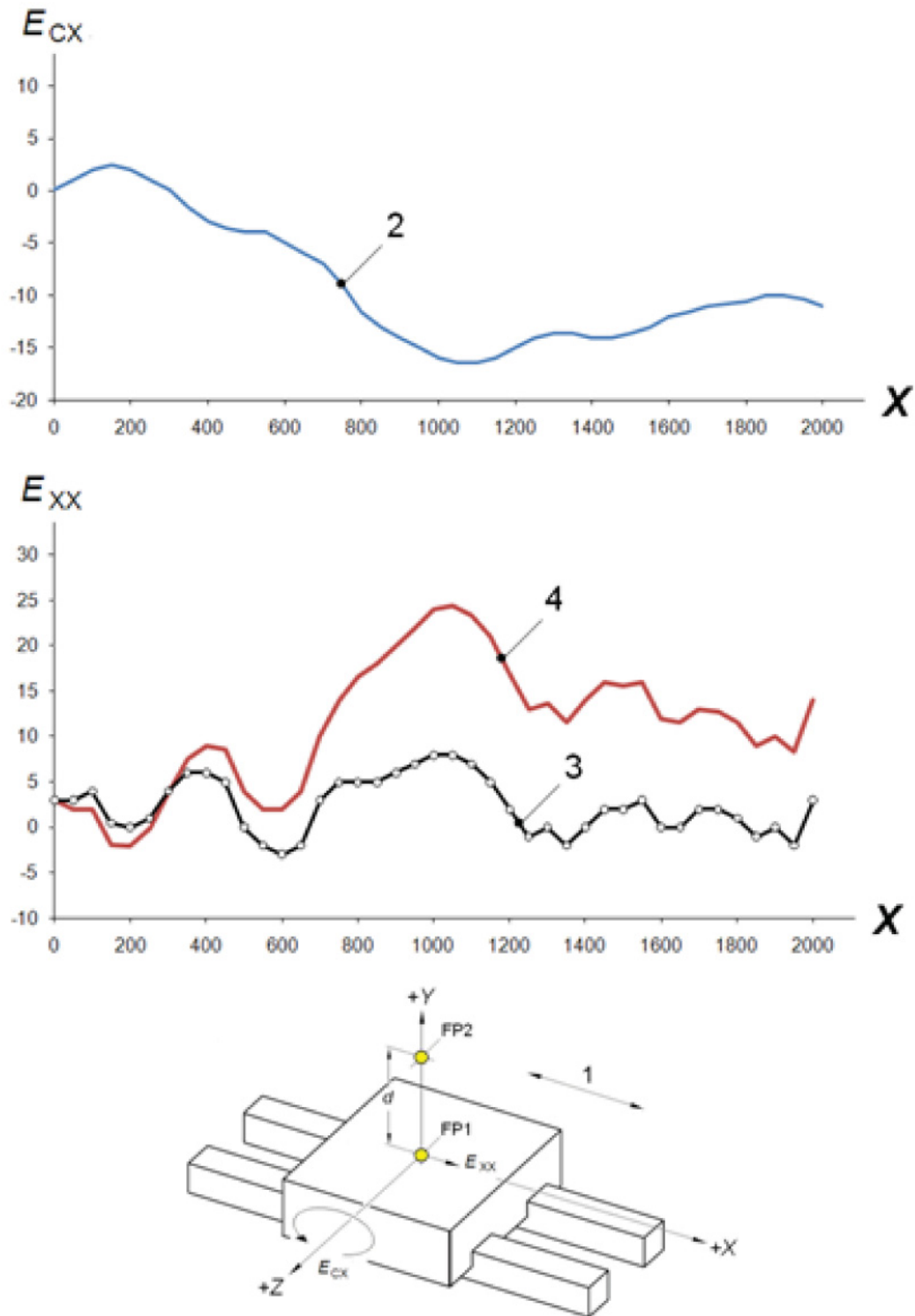

Key

- | | | | |
|----------|--|-----|--|
| X | X-axis coordinates (mm) | 3 | E_{XX} deviations measured at FP1 |
| E_{CX} | angular error motion (μrad) | 4 | E_{XX} deviations at FP2 (assumed to be affected by E_{CX} only) |
| E_{XX} | positioning error motion (μm) | d | Y-axis coordinate difference between FP2 and FP1 (1 000 mm, for the depicted diagrams) |
| 1 | X-axis motion | FP1 | functional point 1 |
| 2 | measured E_{CX} deviations | FP2 | functional point 2 |

Figure 10 — Example of E_{CX} effect on E_{XX}

3.5 Terms for axes of rotation

3.5.1 General

The complete set of definitions related to the geometric accuracy of axes of rotation (i.e. spindles, rotary tables and other rotary axes) are given in ISO 230-7. Some important definitions are repeated in this subclause.

3.5.2

axis of rotation

line segment about which rotation occurs

See Figure 11.

[ISO 230-7:2006, definition 3.1.5]

3.5.3

axis average line

straight line segment located with respect to the reference coordinate axes representing the mean location of the axis of rotation

[ISO 230-7:2006, definition 3.1.10]

3.5.4

axis of rotation error motion

changes in position and orientation of axis of rotation relative to its axis average line as a function of angle of rotation of the rotary axis

See Figure 11 and Figure 12.

NOTE 1 The positive direction of linear (error) motion is that which increases the positive position values and decreases the negative position values (see ISO 841:2001, 5.2.1). The positive direction for the angular error motion is in the direction to advance right-hand screws in the positive direction of linear motion (see Figure 1).

NOTE 2 Error motions are identified by the letter *E* followed by a subscript, where the first letter is the name of the axis corresponding to the direction of the error motion and the second letter is the name of the axis of motion (see Figure 12 and Annex A).

NOTE 3 Adapted from ISO 230-7:2006, definition 3.2.1.

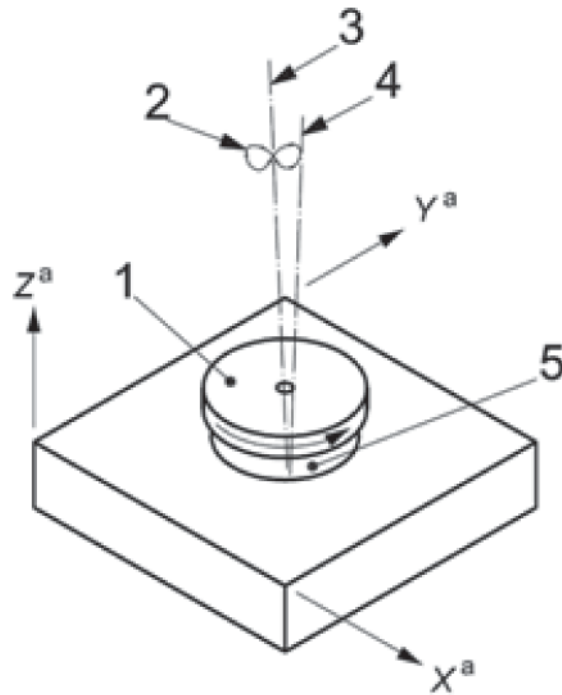

Key

- 1 spindle (rotor)
- 2 error motion of axis of rotation (prior to angle C)
- 3 axis average line
- 4 axis of rotation (at angle C)
- 5 spindle housing (stator)
- ^a Reference axis.

Figure 11 — Reference coordinate axes, axis of rotation, axis average line and error motion for a rotary axis (C-axis)

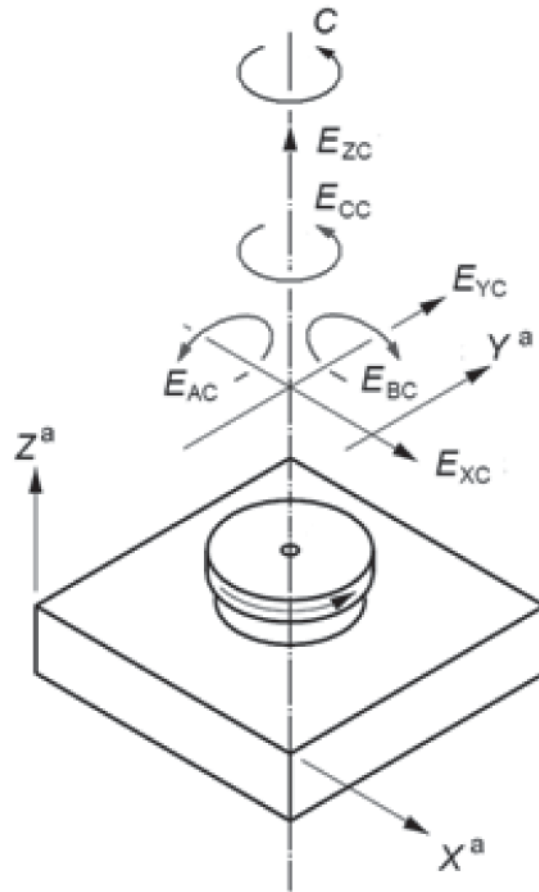

Key

- E_{XC} radial error motion of C in X-direction
- E_{YC} radial error motion of C in Y-direction
- E_{ZC} axial error motion of C
- E_{AC} tilt error motion of C around X-axis
- E_{BC} tilt error motion of C around Y-axis
- E_{CC} angular positioning error motion of C; measured angular positioning deviations of C-axis

^a Reference axis.

NOTE See ISO 230-7.

Figure 12 — Error motions of an axis of rotation

3.5.5 axial error motion

error motion coaxial with the axis average line

[ISO 230-7:2006, definition 3.2.13]

3.5.6 radial error motion

error motion in a direction perpendicular to the axis average line at a specified axial location

[ISO 230-7:2006, definition 3.2.10]

3.5.7

tilt error motion

error motion in an angular direction relative to the axis average line

[ISO 230-7:2006, definition 3.2.12]

NOTE “Coning”, “wobble”, “swash”, “tumbling” and “towering” are non-preferred terms for tilt error motion.

3.5.8

axis shift

(axes of rotation) quasi-static change in location and orientation of the axis average line due to a change in conditions

See Figure 13.

NOTE 1 Causes of axis shift include temperature changes, load changes and speed changes (see ISO 230-7:2006, 3.7).

NOTE 2 Location and orientation errors are identified by the letter *E* followed by a subscript where the first character is the name of the axis corresponding to the direction of the error, the second character is the numeral 0 (zero) and the third character is the name of the axis of motion (see Figure 13); see Annex A.

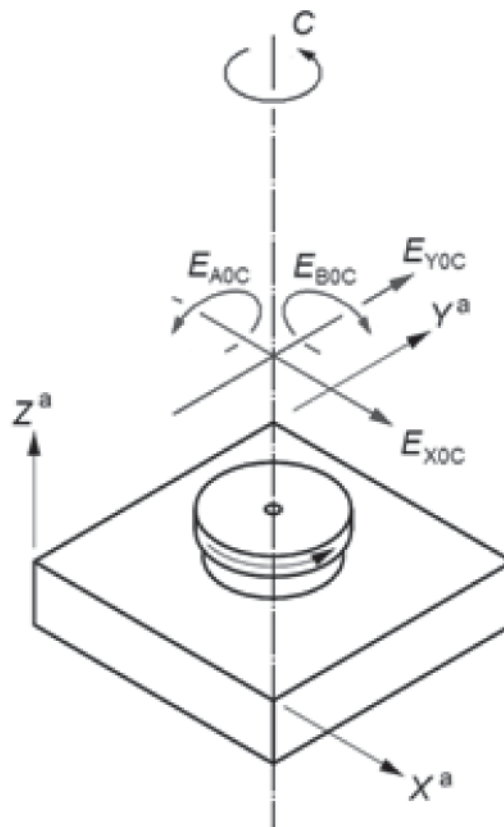

Key

E_{X0C} error of the position of C in X-axis direction

E_{Y0C} error of the position of C in Y-axis direction

E_{A0C} error of the orientation of C in the A-axis direction; squareness of C to Y

E_{B0C} error of the orientation of C in the A-axis direction; squareness of C to X

^a Reference axis.

Figure 13 — Location and orientation errors of axis average line

3.5.9
eccentricity of a driven axis

distance between a driven axis and an axis of rotation when the first is rotated around the second and is nominally parallel to it

See Figure 14.

NOTE Eccentricity is not an error, but a dimension subject to tolerances.

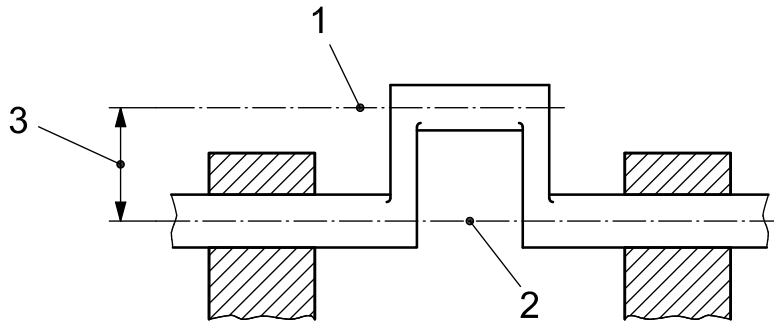

Key

- 1 axis of rotation
- 2 driven axis
- 3 specified eccentricity

Figure 14 — Eccentricity between a driven axis and an axis of rotation

3.5.10
radial throw of a rotary axis at a given point

distance between the geometric axis of a part (or test artefact) connected to a rotary axis and the axis average line, when the two axes do not coincide

See Figure 15.

NOTE 1 The geometric axis of the part (or test artefact) is derived from part (or test artefact) measurements conducted at different axial locations.

NOTE 2 Where the part (or test artefact) form error and the radial error motion are negligible, the radial throw of the axis at a given point is half the **run-out** (3.9.7) measured at such a point.

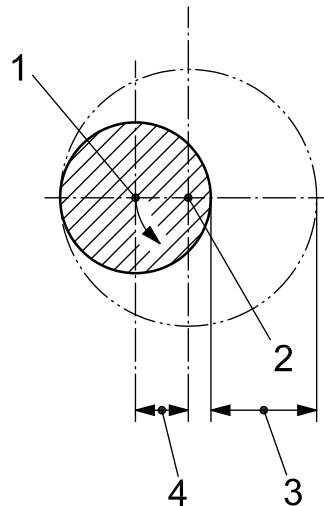

Key

- 1 geometric axis
- 2 axis of rotation
- 3 run-out
- 4 radial throw

Figure 15 — Radial throw and run-out of an axis at a given point

**3.5.11
angular positioning error motion**

unwanted motion along the direction of rotary motion that results in the actual local angular position reached by the rotating component at the functional point differing from the local commanded position

See Figure 16.

NOTE 1 The positive sign of the angular positioning error motion is in the direction of the positive angular motion (according to ISO 841).

NOTE 2 Angular positioning error motion is associated with imperfections of the rotating component angular positioning and its guiding system. It is not associated with the dynamic response of the rotating component and its positioning servo control system.

**3.5.12
angular positioning deviation**

actual angular position reached by the moving component minus the commanded angular position in the plane perpendicular to the axis average line

NOTE 1 The positive sign of the angular positioning deviation is in the direction of positive angular motion (see Figure 16).

NOTE 2 ISO 230-2 defines parameters and test procedures for the positioning accuracy and repeatability of continuous numerically controlled axes.

NOTE 3 Angular positioning deviations, measured in accordance with the requirements of ISO 230-2, constitute a limited representation of angular positioning error motion.

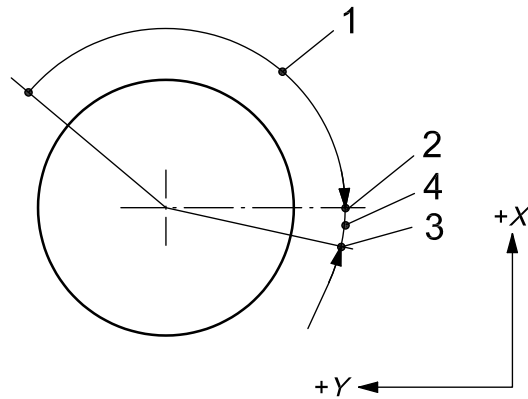

Key

- 1 C-axis negative motion direction
- 2 target position
- 3 actual position
- 4 angular positioning deviation (negative)

Figure 16 — Angular positioning deviation of the C-axis

3.5.13

angular positioning error

angular positioning accuracy

accuracy of angular positioning

value of the largest positive angular positioning deviation added to the absolute value of the largest negative angular positioning deviation, evaluated in accordance with specified conventions

NOTE This definition only applies to axes that are not continuously numerically controlled. Accuracy of angular positioning of continuous numerically controlled axes is established and determined in accordance with ISO 230-2.

3.5.14

unidirectional repeatability of angular indexing

range of angular positioning deviations resulting from a series of trials when approaching any one angular target position under the same conditions of direction and speed of approach

NOTE 1 This parameter includes the effects of clamping at each target position, where applicable, and angular play.

NOTE 2 The repeatability of continuous numerically controlled angular positioning is established and determined in accordance with ISO 230-2.

3.5.15

bidirectional repeatability of angular indexing

range of angular positioning deviations resulting from a series of trials when approaching any one angular target position from both directions of motion for the same speed of approach

NOTE 1 This parameter includes the effects of clamping at each target position, where applicable, and angular play.

NOTE 2 The repeatability of numerically controlled angular positioning is established and determined in accordance with ISO 230-2.

3.6 Terms for parallelism error and squareness error of axes of motion

3.6.1 General

The orientations of axis of motion with respect to each other are generally affected by geometric imperfections of assembly of machine components (e.g. alignment of guideways, bearing surfaces). However, linear and angular error motions of the moving components also affect the orientation of these axes by introducing local perturbations/deviations.

Therefore, specification and measurement of the relative orientation between the trajectory of the functional point of a linear moving component and

- a) a functional surface (support or slideway),
- b) a straight line (axis average line or intersection of planes), or
- c) the trajectory of a functional point on another linear moving component

require disregarding (avoiding) the effects of local perturbations on the trajectory itself and the effects of local perturbations on the reference (datum) element. These objectives are reached by associating the relevant reference straight lines to linear motion trajectories and by associating the reference straight line or the reference plane to datum elements; thus, new definitions for squareness error and parallelism error related to axes of motion (as opposed to the definitions contained in the previous edition of this part of ISO 230) do not include straightness and flatness deviations.

Definitions (as opposed to the previous edition of this part of ISO 230) for parallelism error, related to linear and rotary axes of motion, consider the term “parallelism” as the property of two straight lines that have the same angle of inclination to the abscissa of a common coordinate plane.

Definitions (as opposed to the previous edition of this part of ISO 230) for squareness error, related to linear and rotary axes of motion, consider the term “squareness” as the property of two straight lines where the angle between the two is 90°.

Error parameters for orientation of coordinate axes are identified by the following notations: The first character after *E* (for error) is the name of the axis corresponding to the direction of deviation, the second character is the numeral 0 (zero) accompanied with the chosen reference (datum) axis, the last character is the name of the coordinate axis of concern (see Annex A).

EXAMPLE 1 Squareness error of Z relative to X: $E_{B(0X)Z}$; if X is primary or secondary axes the notation may be simplified as E_{B0Z} .

EXAMPLE 2 Parallelism error (in ZX plane) of Z relative to W: $E_{B(0W)Z}$.

NOTE The actual trajectory of the functional point of a moving component, commanded to move along a nominal straight-line trajectory, is not a straight line. Measurements constitute a sampling of the actual trajectory and a limited representation of it. Parallelism error and squareness error, related to linear and rotary axes of motion, are defined considering the angular relationship between the reference straight lines associated with the measured deviations of the actual trajectories.

These new definitions in this edition shall not be confused with parallelism error and perpendicularity error of components and machine functional surfaces addressed in 3.9, where direct compliance to parallelism error and perpendicularity error definitions derived from other International Standards (e.g. ISO 1101) is specified.

3.6.2 parallelism error between two axes of linear motion

angle between (orientation of) the reference straight line of the trajectory of the functional point of a linear moving component and (in relation to) that of another linear (datum) component, measured on two common orthogonal planes

See Figure 17.

NOTE 1 The sign of the angle of inclination follows the right-hand rule for a rotation around an axis of the machine coordinate system, as described in ISO 841.

NOTE 2 Parallelism error has a positive sign when the difference between the inclination of the reference straight line associated with the referred axis and the inclination of the reference line associated with the datum axis yields a positive result. Parallelism error sign is reversed when the referred axis and the datum axis are swapped; for example, parallelism error between Z-axis (referred axis) and W-axis (datum axis) has an opposite sign to parallelism error between W-axis (referred axis) and Z-axis (datum axis).

NOTE 3 Referred axis straightness deviations and datum axis straightness deviations are measured with respect to a common physical straightness reference. For each one of the two coordinate planes, parallelism error between Z-axis and W-axis is typically measured by recording the readings of a linear displacement sensor fixed to the spindle housing, sensing a (stationary) point on the table while Z-axis and W-axis are commanded to move simultaneously in opposite directions. The angle of inclination of the reference straight line associated with the recorded readings represents the parallelism error.

NOTE 4 For the example of Figure 17, Equations (1) and (2) apply:

$$E_{B(0W)Z} = \theta_{Z,ZX} - \theta_{W,ZX} \quad (1)$$

and

$$E_{A(0W)Z} = \theta_{Z,YZ} - \theta_{W,YZ} \quad (2)$$

NOTE 5 Parallelism error evaluation over short measurement lengths can tend to lose significance.

3.6.3 parallelism error between two axes of rotation

angle between (orientation of) the axis average line of a rotating component and (in relation to) the axis average line of another (datum) rotating component, evaluated in two orthogonal planes

NOTE 1 The common reference for the determination of inclinations is the positive direction of the machine principal axis associated with the axes of rotation.

NOTE 2 Parallelism error has a positive sign when the difference between the inclination of the average line associated with the referred axis (spindle axis in Figure 18) and the inclination of the average line associated with the datum axis (C-axis in Figure 18) yield a positive result.

NOTE 3 For the example of Figure 18, Equations (3) and (4) apply:

$$E_{B(0C)C1} = \theta_{C1,ZX} - \theta_{C,ZX} \quad (3)$$

and

$$E_{A(0C)C1} = \theta_{C1,YZ} - \theta_{C,YZ} \quad (4)$$

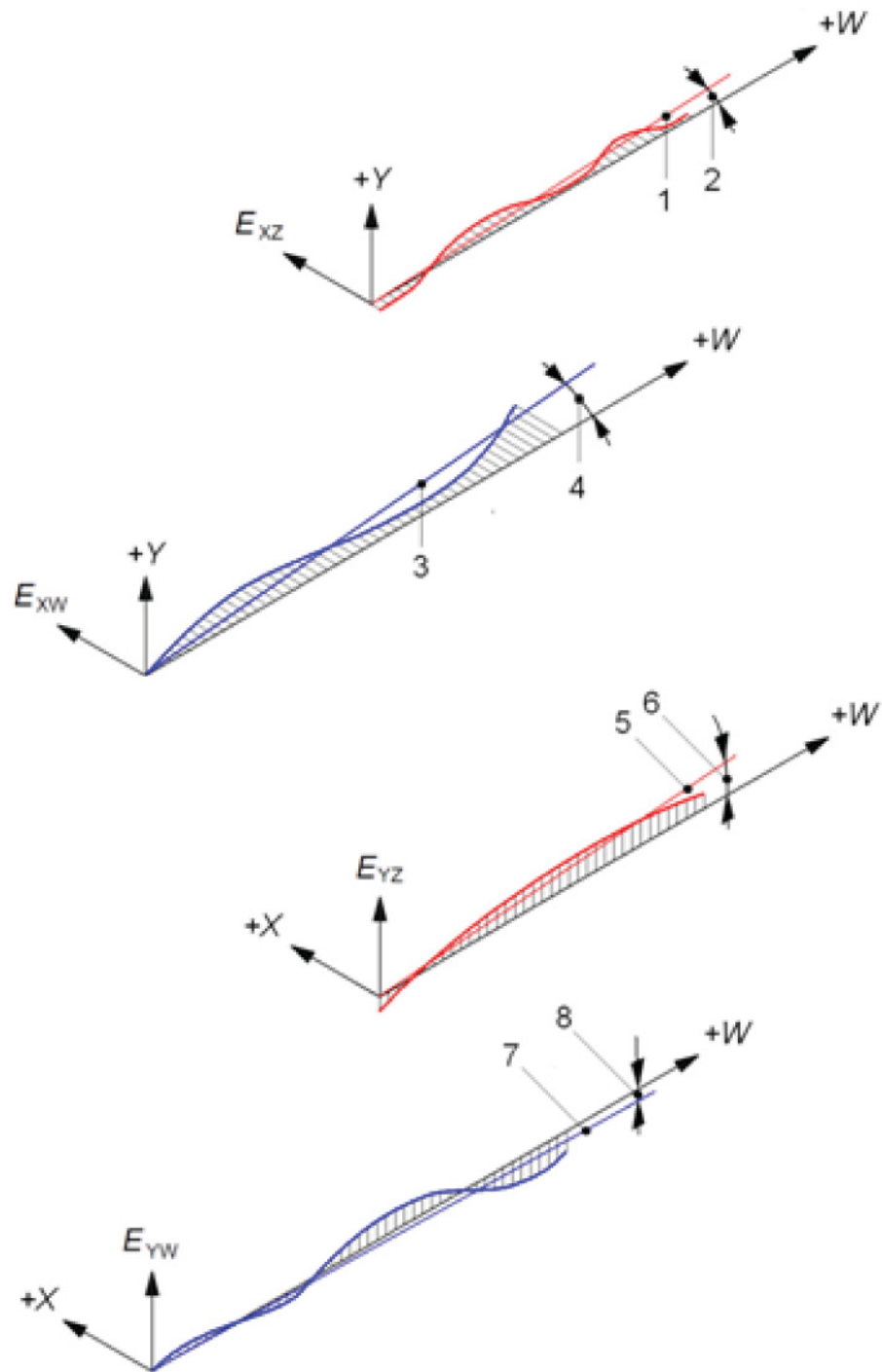
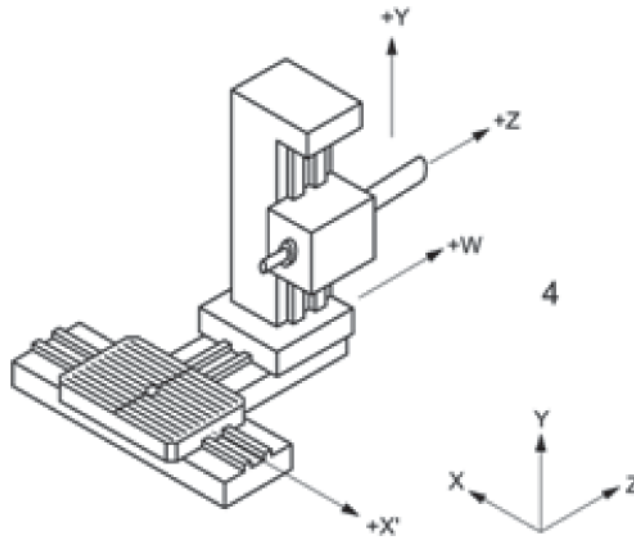

Figure 17 — Example of parallelism error between Z-axis and W-axis in ZX and YZ planes (*continued*)



Key

- E_{XZ} Z-axis straightness deviations, measured in the ZX plane, with respect to a physical straightness reference aligned with the W-axis
- E_{XW} W-axis straightness deviations, measured in the ZX plane, with respect to a physical straightness reference aligned with the W-axis
- 1 reference straight line associated to E_{XZ}
- 2 E_{XZ} reference straight line inclination; $\theta_{Z,ZX}$ (positive value, as shown)
- 3 reference straight line associated to E_{XW}
- 4 E_{XW} reference straight line inclination; $\theta_{W,ZX}$ (positive value, as shown)
- E_{YZ} Z-axis straightness deviations, measured in the YZ plane, with respect to a physical straightness reference aligned with the W-axis
- E_{YW} W-axis straightness deviations, measured in the YZ plane, with respect to a physical straightness reference aligned with the W-axis
- 5 reference straight line associated to E_{YZ}
- 6 E_{YZ} reference straight line inclination; $\theta_{Z,YZ}$ (negative value, as shown)
- 7 reference straight line associated to E_{YW}
- 8 E_{YW} reference straight line inclination; $\theta_{W,YZ}$ (positive value, as shown)

NOTE See Note 4 of 3.6.2.

Figure 17 — Example of parallelism error between Z-axis and W-axis in ZX and YZ planes

3.6.4

parallelism error between an axis of linear motion and an axis of rotation

angle between (orientation of) the reference straight line of the trajectory of the functional point of a linear moving component and (in relation to) the axis average line of a (datum) rotating component, evaluated in two orthogonal planes

3.6.5

parallelism error between an axis of linear motion and a surface

angle between (orientation of) the reference straight line of the trajectory of the functional point of a linear moving component and (in relation to) a (datum) machine functional surface

NOTE The common reference for the determination of inclinations is the positive direction of the (common) associated machine principal axis.

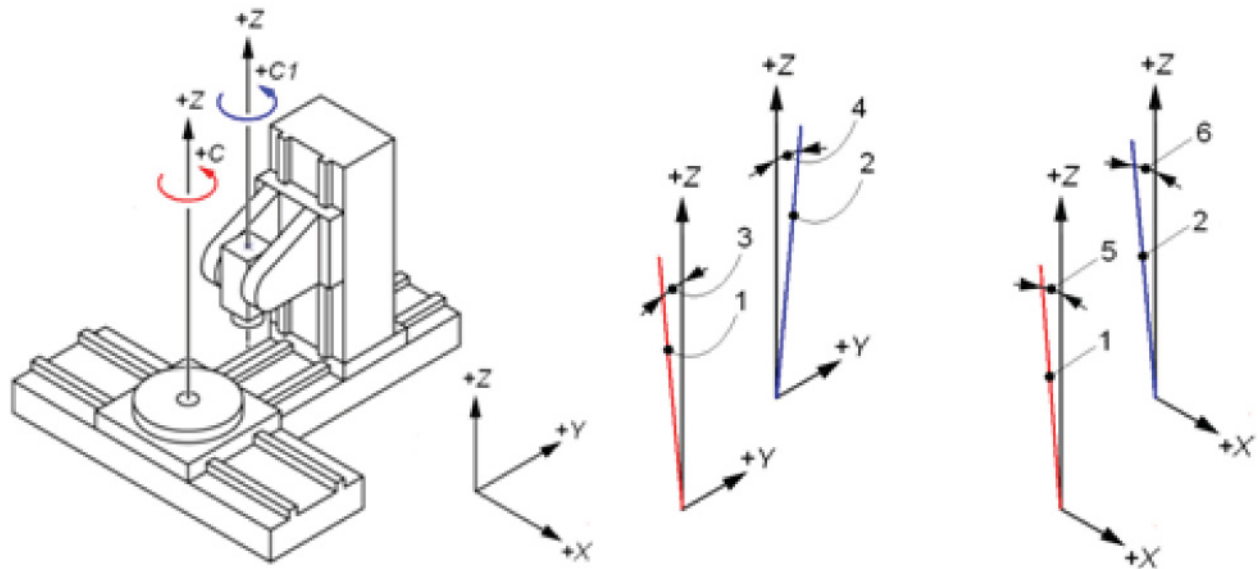

Key

- +C1 spindle axis (referred axis)
- +C rotary table (datum axis)
- +Z common reference for inclination evaluation
- 1 C-axis average line
- 2 C1-axis (spindle axis) average line

- 3 C-axis average line inclination in YZ plane; $\theta_{C,YZ}$ (positive value, as shown)
- 4 C1-axis average line inclination in YZ plane; $\theta_{C1,YZ}$ (negative value, as shown)
- 5 C-axis average line inclination in ZX plane; $\theta_{C,ZX}$ (negative value, as shown)
- 6 C1-axis average line inclination in ZX plane; $\theta_{C1,ZX}$ (negative value, as shown)

NOTE See Note 3 of 3.6.3.

Figure 18 — Example of parallelism error between C-axis and spindle axis

3.6.6

parallelism error between an axis of rotation and a surface

angle between (orientation of) the axis average line of a rotating component and (in relation to) the reference plane associated to a machine functional surface

NOTE The common reference for the determination of inclinations is the positive direction of the (common) associated machine principal axis.

3.6.7

squareness error between two axes of linear motion

difference between the inclination of the reference straight line of the trajectory of the functional point of a linear moving component with respect to its corresponding principal axis of linear motion and (in relation to) the inclination of the reference straight line of the trajectory of the functional point of another linear moving component with respect to its corresponding principal axis of linear motion

See Figure 19.

NOTE 1 This definition is conceptually different from the definition for **perpendicularity error between two functional lines** (3.9.5).

NOTE 2 A positive squareness error corresponds to a positive angular error in the orientation of the referred axis relative to the datum axis, following the right-hand rule for rotations as described in ISO 841. The squareness error sign is reversed when the referred axis and the datum axis are swapped; for example, the squareness error between the X-axis (referred axis) and Y-axis (datum axis) has an opposite sign to the squareness error between the Y-axis (referred axis) and X-axis (datum axis). To avoid confusion, squareness errors may also be accompanied with additional text like “larger than 90°” or “smaller than 90°”.

NOTE 3 For the example of Figure 19, Equation (5) applies:

$$E_{B(0Z)X} = E_{B0X} = \theta_{X,ZX} - \theta_{Z,ZX} \tag{5}$$

NOTE 4 Squareness error evaluation over short measurement lengths can tend to lose significance.

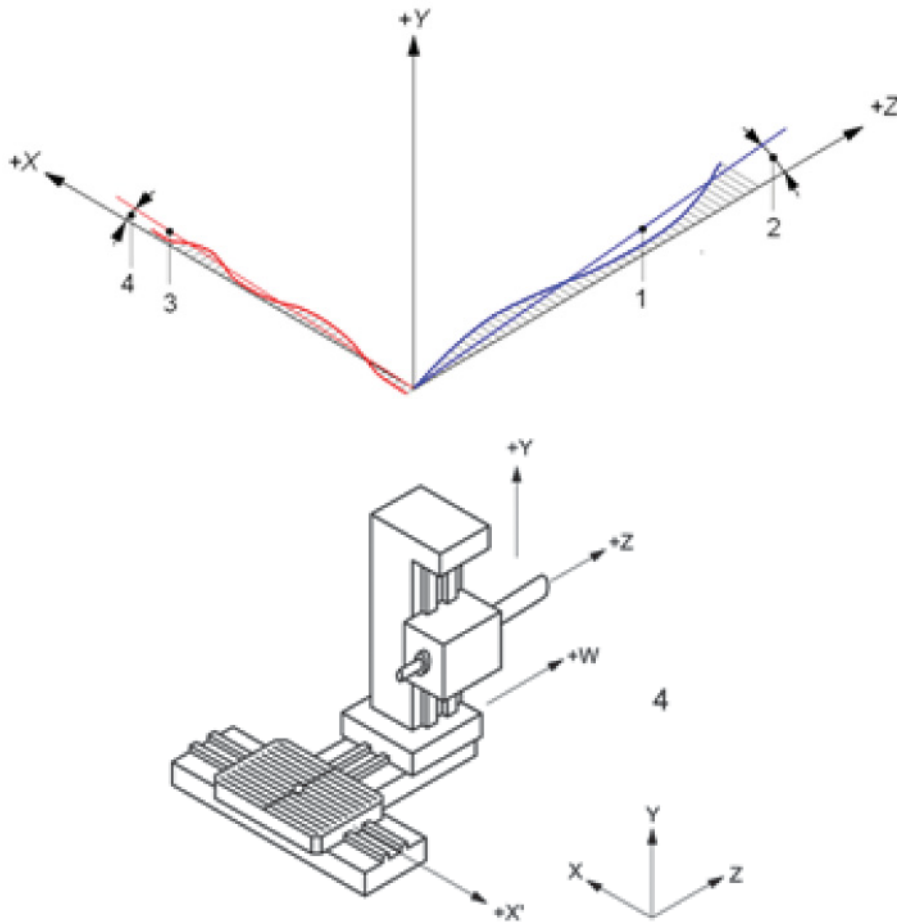

Key

- 1 reference straight line associated to E_{XZ}
- 2 E_{XZ} reference straight line inclination; $\theta_{Z,ZX}$ (positive value, as shown)
- 3 reference straight line associated to E_{ZX}
- 4 E_{ZX} reference straight line inclination; $\theta_{X,ZX}$ (negative value, as shown)

NOTE See NOTE 3 of 3.6.7.

Figure 19 — Example of squareness error between X- and Z-axis of linear motion

3.6.8 squareness error between an axis of linear motion and an axis average line

angular deviation from 90° between the reference straight line of the trajectory of a point on a linear moving component and (in relation to) the axis average line of a rotating component of the machine

NOTE The positive direction associated with the axis of rotation is taken as the positive direction of the linear motion resulting from the right-hand rule according to ISO 841.

3.6.9

squareness error between two axis average lines

angular deviation from 90° between the axis average line of a rotating component of the machine and (in relation to) the axis average line of another rotating component of the machine

3.7 Terms for other relationships between axis average lines

3.7.1

offset between two axis average lines

distance, in the radial direction, between two nominally parallel axis average lines at a specified position in the axial direction

3.7.2

coaxiality error of axis average lines

offset at a specified location and angle between two nominally coaxial axis average lines, evaluated in two orthogonal planes

See Figure 20.

NOTE 1 This definition considers the term “coaxiality” as the property of two straight lines, where the two lines are parallel with zero offset.

NOTE 2 Coaxiality error is represented by two offsets at a specified location and two angles of parallelism evaluated in two orthogonal planes.

NOTE 3 Coaxiality error is measured in two perpendicular planes similar to parallelism error measurements.

NOTE 4 The terms “coincidence” and “alignment” are not preferred.

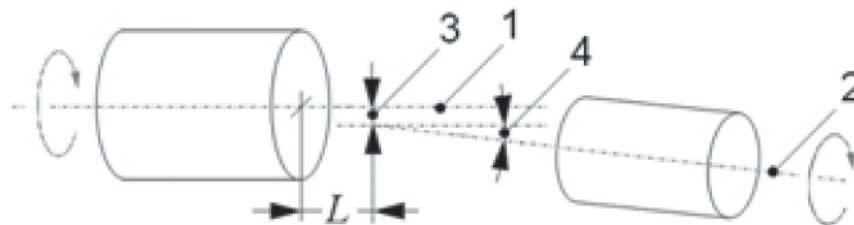

Key

- 1 axis average line 1
- 2 axis average line 2
- 3 offset of coaxiality deviation (measured in one plane)
- 4 angle of coaxiality deviation (measured in one plane)
- L* specified distance for offset measurement

**Figure 20 — Example of coaxiality error of axis average lines
 (depicted in one of the two orthogonal planes)**

3.7.3

equidistance error of axis average lines

difference between the distance of an axis average line and a reference plane, and the distance of another axis average line and the same reference plane

3.7.4

error of intersection between axis average lines

shortest actual distance between two nominally intersecting axis average lines

See Figure 21.

NOTE The projections of the two non-intersecting axis average lines intersect at a point on their symmetry plane. The shortest actual distance between the two axis average lines is the diameter of the sphere, centred in their projections intersection point, tangent to the two axis average lines.

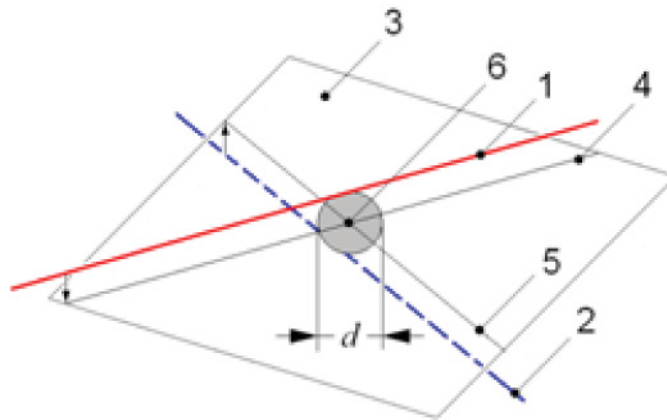

Key

- 1 axis average line 1
- 2 axis average line 2
- 3 symmetry plane
- 4 projection of axis average line 1 on the symmetry plane
- 5 projection of axis average line 2 on the symmetry plane
- 6 intersecting point of projections 4 and 5
- d diameter of the sphere centred on 6 and tangent to the two axis average lines 1 and 2; error of intersection

Figure 21 — Error of intersection between axis average lines

3.8 Terms for multi-axes motion or kinematic tests

3.8.1

synchronous motion

motion of the workpiece and/or the tool along a predetermined path in space, involving the motions of two or more axes, simultaneously coordinated by the machine controller

3.8.2

circular error

minimum radial separation between two concentric reference circles enveloping the actual circular path resulting from synchronous motion

See Figure 22.

NOTE 1 Reference circle may be **mean minimum zone circle** (3.8.3) or **least squares circle** (3.8.4).

NOTE 2 Circular error is different from the term “roundness”, which is related to parts and machine tool functional surfaces; the use of the term “roundness” in association to synchronous motion is not appropriate.

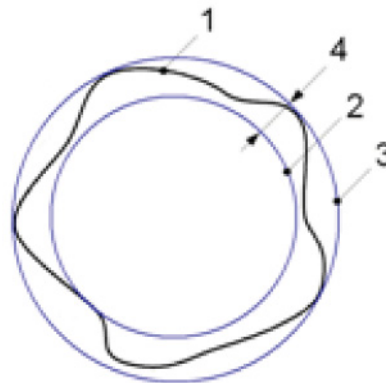

Key

- 1 circular path
- 2,3 minimum zone circles
- 4 minimum radial separation; circular deviation

Figure 22 — Example of circular path showing circular deviation

3.8.3

mean minimum zone circle

arithmetic mean of two concentric circles enclosing the actual circular path and having the least radial separation

NOTE Adapted from ISO 12181-1:2011, definition 3.3.1.1.

3.8.4

least squares circle

associated circle fitting the actual circular path such that the squares of the local circular deviations is a minimum

NOTE Adapted from ISO 12181-1:2011, definition 3.3.1.2.

3.8.5

flatness

property of a plane

[ISO 12781-1:2011, definition 3.1.1]

3.8.6

surface generated by two linear motions

set of functional points obtained by the combined motion of two linear components commanded to move on a (nominal) plane, creating a virtual surface

See Figure 23.

NOTE The expression “virtual surface” is conceptually similar to the “flatness surface” defined in ISO 12781-1:2011, 3.2.2, referring to the extracted surface representing a real surface.

3.8.7

flatness deviation

deviation of a point (on a surface generated by two linear motions) from a reference plane, the deviation being normal to the reference plane

NOTE 1 Adapted from ISO 12781-1:2011, definition 3.2.3.

NOTE 2 The positive sign of the flatness deviation being in the positive direction according to ISO 841.

3.8.8
reference plane

associated plane fitting the surface generated by two linear motions in accordance with specified conventions, to which the deviations from flatness and the flatness parameters are referred

NOTE Adapted from ISO 12781-1:2011, definition 3.3.1.

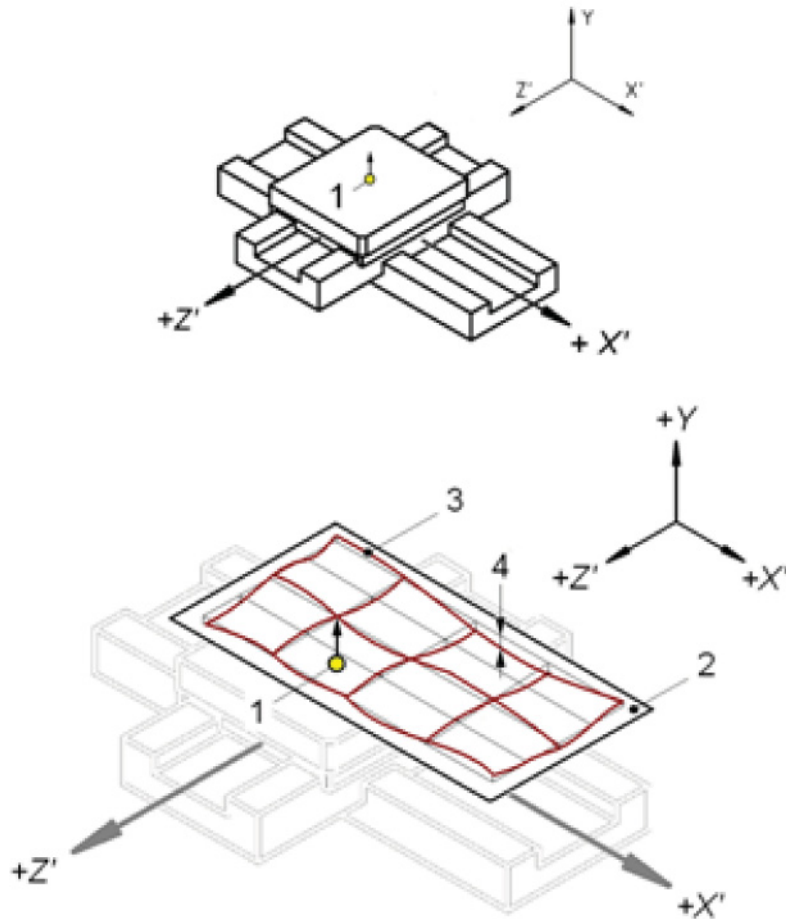

Key

- 1 functional point
- 2 reference plane
- 3 trajectory of functional point
- 4 local flatness deviation

Figure 23 — Plane defined by two linear motions

3.8.9
mean minimum zone reference plane

arithmetic mean plane of two parallel planes enclosing the surface generated by two linear motions and having the least separation

See Figure 24.

NOTE Adapted from ISO 12781-1:2011, definition 3.3.1.1.

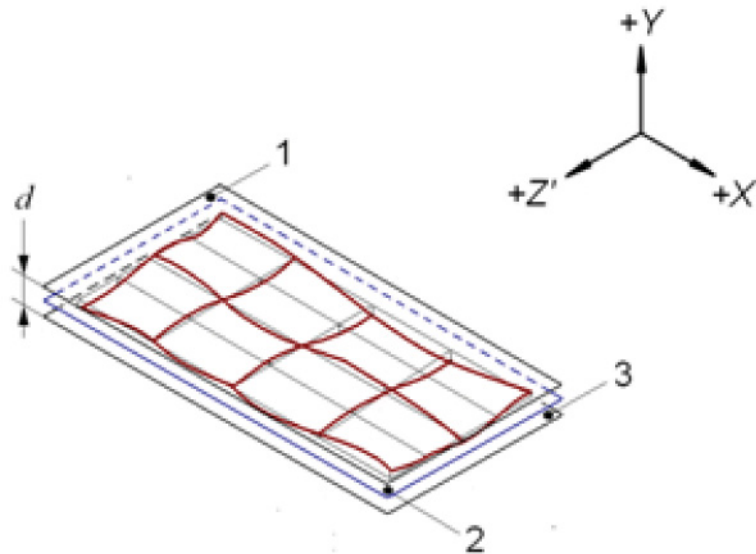

Key

- 1 upper minimum zone reference plane
- 2 mean minimum zone reference plane
- 3 lower minimum zone reference plane
- d* least separation

Figure 24 — Minimum zone reference planes

3.8.10

least squares zone reference plane

plane such that the sum of the squares of the flatness deviations is a minimum

NOTE Adapted from ISO 12781-1:2011, definition 3.3.1.2.

3.8.11

flatness error of a surface defined by two linear motions

value of the largest positive flatness deviation added to the absolute value of the largest negative flatness deviation (with respect to any previously defined reference planes)

NOTE The minimum flatness error is evaluated by using minimum zone reference planes.

3.8.12

volumetric accuracy for three linear axes

V_{XYZ}

maximum range of relative deviations between actual and ideal position in X-, Y- and Z-axis directions and maximum range of orientation deviations for A-, B- and C-axis directions for X-, Y- and Z-axis motions in the volume concerned, where the deviations are relative deviations between the tool side and the workpiece side of the machine tool for specified primary and secondary axes of alignment

See Figure 25.

There are six statements for the volumetric accuracy, V_{XYZ} : one for each translational and one for each rotational range of deviations:

- | | | | |
|-------------|--|-------------|--|
| $V_{XYZ,X}$ | maximum X-axis relative deviations range | $V_{XYZ,A}$ | maximum deviations range in A-axis direction |
| $V_{XYZ,Y}$ | maximum Y-axis relative deviations range | $V_{XYZ,B}$ | maximum deviations range in B-axis direction |
| $V_{XYZ,Z}$ | maximum Z-axis relative deviations range | $V_{XYZ,C}$ | maximum deviations range in C-axis direction |

The measurement coordinate system used and the following parameters shall be stated:

- tool offset in X, Y, Z;
- volume concerned; X·Y·Z;
- volume centred at position X, Y, Z;
- adopted measurement coordinate system (see Annex A).

NOTE Although the rotary axes of motion also influence the volumetric accuracy of a machine, for simplicity, they are excluded from consideration here.

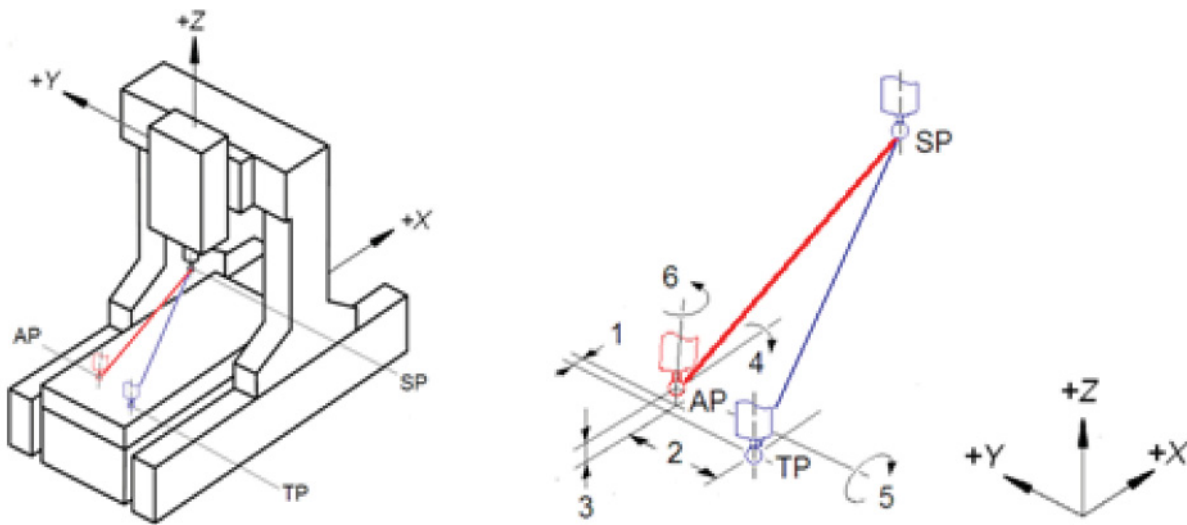

Key

- 1 deviation in X-axis direction
- 2 deviation in Y-axis direction
- 3 deviation in Z-axis direction
- 4 deviation in A-axis direction
- 5 deviation in B-axis direction
- 6 deviation in C-axis direction
- AP actual position
- SP starting position
- TP target position

Figure 25 — Target position deviations

3.8.13 volumetric performance

ability of a machine tool to perform the intended multi-axes functions anywhere within the entire machine working volume or a smaller volume as agreed between the manufacturer/supplier and user

3.9 Terms for geometric accuracy of machine functional surfaces, machine tool components and test pieces

3.9.1 General

Machine tool functional surfaces are actual components. Terms and definitions related to their geometric accuracy are derived from the definitions of tolerances given in ISO 1101.

Terms and definitions for **straightness** (3.4.11), **reference straight line** (3.4.12), **flatness** (3.8.5) and **reference plane** (3.8.8) also apply for components.

Terms and definitions for parallelism error and perpendicularity error between machine functional surfaces are conceptually different from definitions for parallelism error and squareness error related to axis of motion. “Perpendicularity” is the preferred term for the relationship between features pertaining to functional surfaces, to maintain consistency with ISO 1101 and to distinguish it from the term “squareness”, which refers to the angular relationship between geometrical elements involving axes of motion.

3.9.2

straightness error of a functional line in a plane

minimum distance between two straight lines, parallel to the general direction of the line, that just contain all measured points of the referred line

NOTE 1 The general direction of the line or reference straight line is defined so as to minimize the straightness error [see **mean minimum zone reference straight line** (3.4.9)]. It may also be conventionally defined either by two points appropriately chosen near the ends of the line to be checked [see **end-point reference straight line** (3.4.11)] or by a straight line calculated from plotted points [see **least squares reference straight line** (3.4.10)].

NOTE 2 Straightness error of a line in space is specified by the straightness error of its projections in two orthogonal planes.

3.9.3

parallelism error between a functional line and a plane

minimum distance between two straight lines, parallel to a **reference plane** (3.8.8) associated with the (datum) functional plane, that just contain all measured points of the referred line

NOTE 1 Adapted from ISO 1101:2004, 18.9.3.

NOTE 2 Parallelism error according to this definition includes the (referred) line straightness deviations and is conceptually different from the **parallelism error between an axis of linear motion and a surface** (3.6.5).

3.9.4

parallelism error between two functional planes

minimum distance between two planes, parallel to a **reference plane** (3.8.8) associated with the (datum) functional plane, that just contain all measured points of the (referred) functional plane

NOTE 1 Adapted from ISO 1101:2004, 18.9.6.

NOTE 2 Parallelism error according to this definition includes the (referred) functional plane flatness deviations (see Figure 26).

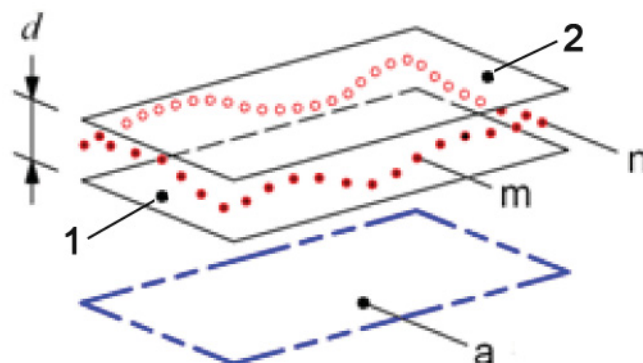

Key

- 1, 2 planes parallel to a
- a reference plane associated to the (datum) functional plane
- n, m measured points of the (referred) functional plane
- d minimum distance; parallelism error

Figure 26 — Parallelism error between two functional planes

3.9.5
perpendicularity error between two functional lines

minimum distance between two parallel planes, perpendicular to a **reference straight line** (3.4.8) associated to the (datum) line, that just contain all measured points of the (referred) functional line

NOTE 1 Adapted from ISO 1101:2004, 18.10.1.

NOTE 2 The datum line may also be the axis average line of a rotating component or the straight line intersecting two reference planes (see Figure 27).

NOTE 3 Perpendicularity error, according to this definition, includes the (referred) line straightness deviations and is conceptually different from **squareness error between two axes of linear motion** (3.6.7).

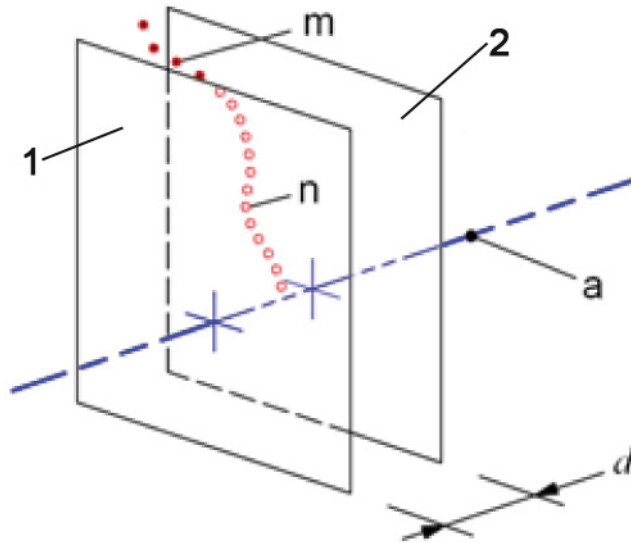

Key

- 1, 2 planes, square to a
- a datum reference straight line
- n, m measured points of the (referred) functional line
- d minimum distance; perpendicularity error

Figure 27 — Perpendicularity error between two functional lines

3.9.6
perpendicularity error between two functional planes

minimum distance between two parallel planes, perpendicular to a **reference plane** (3.8.8) associated to the (datum) plane, that just contain all measured points of the (referred) functional plane

See Figure 28.

NOTE 1 Adapted from ISO 1101:2004, 18.10.5.

NOTE 2 Perpendicularity error, according to this definition, includes the (referred) plane flatness deviations.

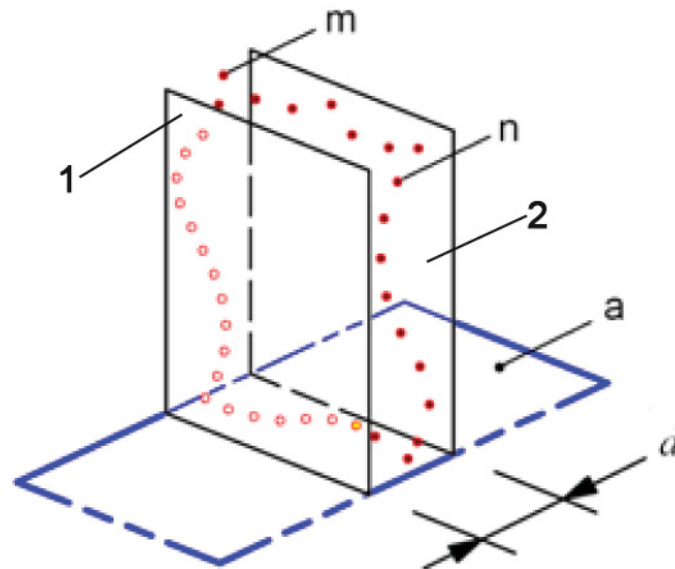

Key

- 1, 2 planes, square to *a* and parallel to each other
- a* datum reference plane
- n*, *m* measured points of the (referred) functional plane
- d* minimum distance; perpendicularity error

Figure 28 — Perpendicularity error between two functional planes

3.9.7

run-out of a functional surface at a given section

total displacement measured by a displacement sensor sensing against a moving surface or moved with respect to a fixed surface

NOTE 1 Adapted from ISO 1101:2004, 18.15.

NOTE 2 Radial run-out is twice the radial throw of an axis in a given section (see Figure 14) when no account is taken of the out-of-roundness or of the radial error motion.

NOTE 3 In general, the measured run-out is the resultant of

- a) the radial throw of the axis at the measurement point (3.5.10),
- b) the out-of-roundness of the component (see ISO 1101:2004, 18.3), and
- c) the radial error motion of the axis of rotation (see ISO 230-7:2006, 3.2.10).

NOTE 4 In geometric testing of machine tools, the radial throw of an axis is measured by observing the run-out of a part mounted on the axis. In order to avoid any confusion in the minds of the personnel in charge of machine testing and to eliminate any risk of error, only the term run-out is used in this part of ISO 230, and the indicated tolerance to be given has been applied systematically to this run-out so that the readings of the measuring instruments are not to be divided by two. The proposed measuring methods take this note into consideration.

NOTE 5 With rolling bearings, the rollers and cage rotate once for more than two rotations of the shaft and it is common for the run-out of a shaft to repeat cyclically every several rotations. To account for these variations, run-out is measured over several (at least two) rotations (see ISO 230-7:2006, 5.4 and 5.5).

NOTE 6 From the metrological point of view, the bearing of a cylindrical or conical surface is said to have an axis exactly coincident with a rotating axis if, on measuring over a given length (after fixing a test mandrel in this bearing, if necessary), the run-out at each measuring point does not exceed the given value.

3.9.8

flatness error of a functional surface

minimum distance between two planes, parallel to the general direction of the plane, that just contains all its measured points and that have minimum separation

NOTE 1 Adapted from ISO 1101:2004, 18.2.

NOTE 2 The general direction of the plane or **reference plane** (3.8.8) is defined so as to minimize the flatness error, i.e. conventionally, either

- by three points conveniently chosen in the plane to be tested (usually the part very near to the edge, having minor local defects, can be disregarded), or
- by a plane calculated from the plotted points by the least squares method (see 3.8.11), or
- by the mean minimum zone reference plane.

3.9.9

coaxiality error of a functional cylinder to a datum straight line

twice the maximum radial distance (evaluated within a specified measuring length) between the median line of the functional cylinder and the datum straight line

NOTE 1 Adapted from ISO 1101:2004, 18.13.2.

NOTE 2 A typical functional cylinder is a quill; a typical datum straight line is its associated spindle axis average line.

4 Tolerances

4.1 General

Tolerances identify the permissible errors of the machine tool characteristic and geometric accuracy parameters being evaluated and shall be specified in accordance with functional requirements. When establishing tolerances, manufacturing, assembling and inspection requirements should also be considered.

Tolerances shall be expressed with the unit of the corresponding measured characteristic under test.

4.1.1 Rules concerning tolerances and conformance zone

Measurement uncertainties should be taken into account (see Clause 5 and 6.3) when specifying tolerances and when evaluating conformance with specified tolerances. The zones of conformance and non-conformance shall be determined in accordance with the rules provided in ISO 14253-1 [see Figure 29 a) and b)].

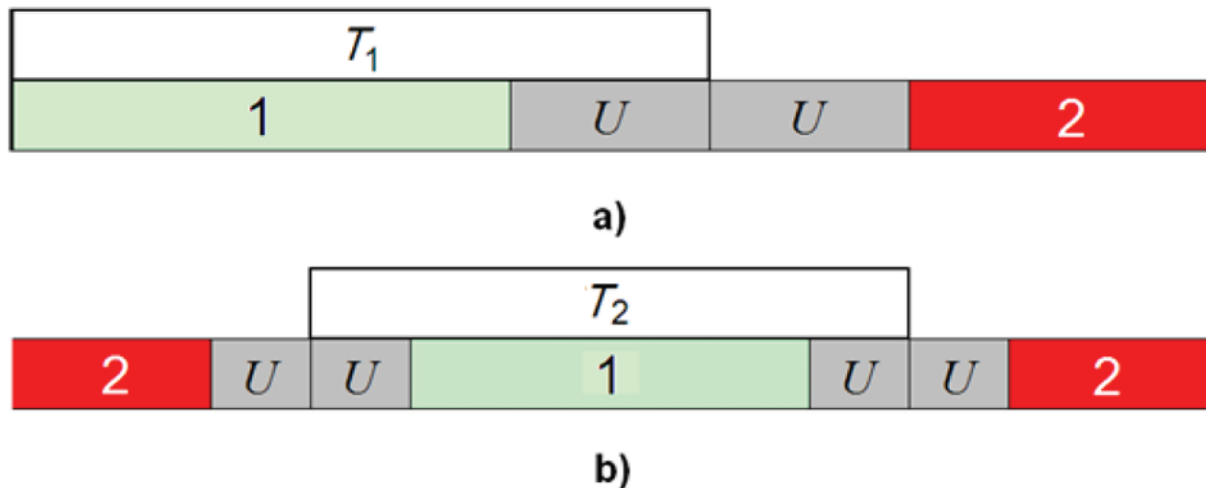

Key

- 1 conformance zone
- 2 non-conformance zone
- T_1 one-sided tolerance zone, e.g. E_{ZX} straightness 0,012 mm
- T_2 two-sided tolerance zone, e.g. 100 mm \pm 0,006 mm
- U measurement uncertainty

Figure 29 — Determination of zones of conformance and non-conformance for one-sided tolerance zone and two-sided tolerance zone

EXAMPLE Tolerance of run-out: x mm
 Measurement uncertainty: y mm
 Maximum permissible difference in the readings during the test: $(x-y)$ mm (zone of conformance)

Other definitions of conformance zone are subject to agreement between the parties involved (supplier/manufacturer and user).

If the determinations of geometric accuracy parameters are repeated, the arithmetical mean of these parameters should be taken. The dispersion of the resulting parameters is one of the contributors to the measurement uncertainty.

4.1.2 Specified measuring boundaries

Unless otherwise specified, for any tests described in this part of ISO 230, tolerances shall indicate the maximum allowable value for the parameter of interest within the specified measurement boundary (measurement length for straightness test, measurement volume for volumetric accuracy test, applied force range for compliance and hysteresis test, etc.).

When the tolerance is specified for a given boundary, the tolerance for another boundary comparable to the first one may be determined by means of the law of proportionality. For example, when a tolerance, T_1 , is given for a specific measurement length of up to L_1 , and a larger tolerance, T_2 , is given for a measurement length, L_2 , a tolerance, T_L , for a measurement length between L_1 and L_2 can be determined by the law of proportionality:

$$L \leq L_1 : T_L = T_1 \tag{6}$$

$$L_1 < L < L_2 : T_L = T_1 + \frac{T_2 - T_1}{L_2 - L_1} (L - L_1) \tag{7}$$

$$L \geq L_2 : T_L = T_2 \tag{8}$$

For measurement lengths greatly different from the specified measurement length (e.g. the available measurement length is 30 mm instead of 300 mm), the law of proportionality cannot be applied.

4.1.3 Local tolerances

Unless otherwise specified, tolerances apply to measurement results obtained over the entire measurement boundary. It may be desirable to specify a local tolerance with reference to a partial measurement boundary.

Local tolerances shall not be established by the simple application of the law of proportionality. Specification of local tolerances shall take into account functional requirements and inspection requirements associated to the characteristic under test or to the component under test.

Local straightness error specification for axis of linear motion directly applies to definition 3.4.10, but the reference straight line is evaluated over the local measurement length (see Figure 30).

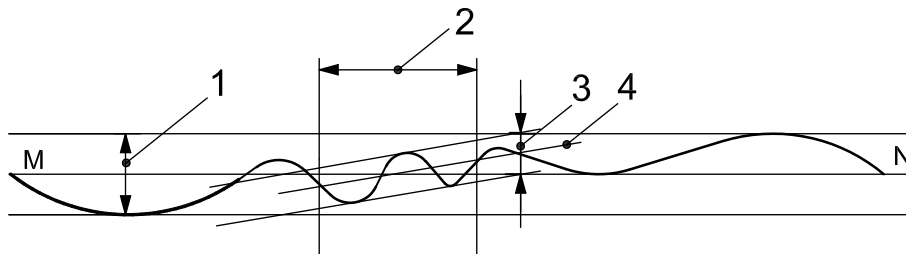

Key

- 1 total straightness error
- 2 local measurement length
- 3 local straightness error
- 4 end-points reference straight line associated to local straightness measurement results
- MN end-points reference straight line associated to straightness measurements conducted over the full measurement length

Figure 30 — Local straightness error

Additional attention shall be devoted to clearly specify local tolerances for parallelism error and squareness error between axes of linear motion.

Parallelism error and squareness error between axes of linear motion refer to the angular relationship between the reference straight lines associated to the referred axis trajectory and to the datum axis trajectory.

When specifying and testing local parallelism error and local squareness error, it shall be clearly stated whether the reference straight line associated to the datum axis trajectory shall be evaluated from the results obtained from measurements over the full travel of the datum axis or if it shall be evaluated from the results obtained from measurements over the local travel of the datum axis (see Figures 31, 32 and 33).

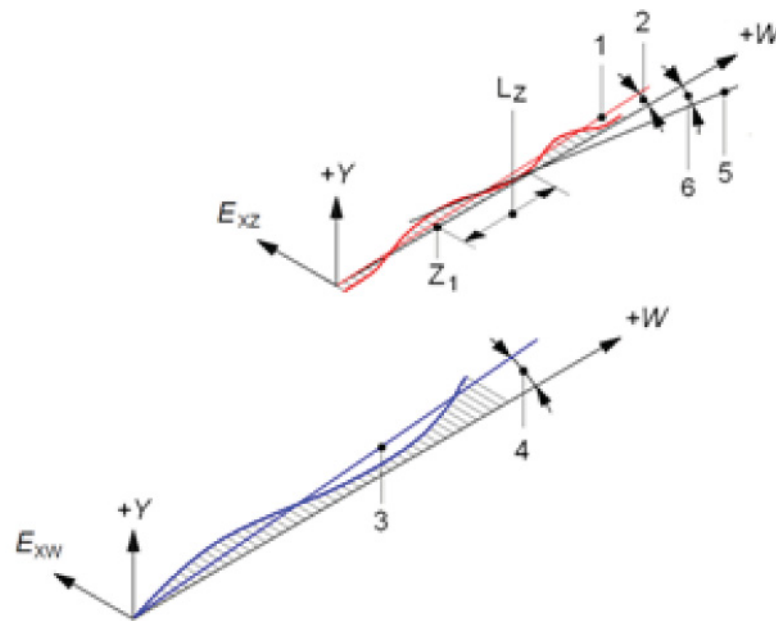

Key

E_{XZ} Z-axis straightness deviations, measured in the ZX plane, with respect to a physical straightness reference aligned with the W-axis

E_{XW} W-axis straightness deviations, measured in the ZX plane, with respect to a physical straightness reference aligned with the W-axis

L_Z local Z-axis measurement length

1 reference straight line associated to E_{XZ} measurements over the full Z-axis travel

2 inclination of reference straight line 1; $\theta_{Z1,ZX}$ (positive value, as shown)

3 reference straight line associated to E_{XW}

4 E_{XW} reference straight line inclination; $\theta_{W,ZX}$ (positive value, as shown)

5 reference straight line associated to E_{XZ} measurements over measurement length L_Z starting at Z_1

6 inclination of reference straight line 5; $\theta_{ZL,ZX}$ (negative value, as shown)

NOTE Local parallelism error: $\theta_{Z1,ZX} - \theta_{W,ZX}$.

Figure 31 — Evaluation of local Z-axis parallelism error with respect to the full travel of the datum W-axis

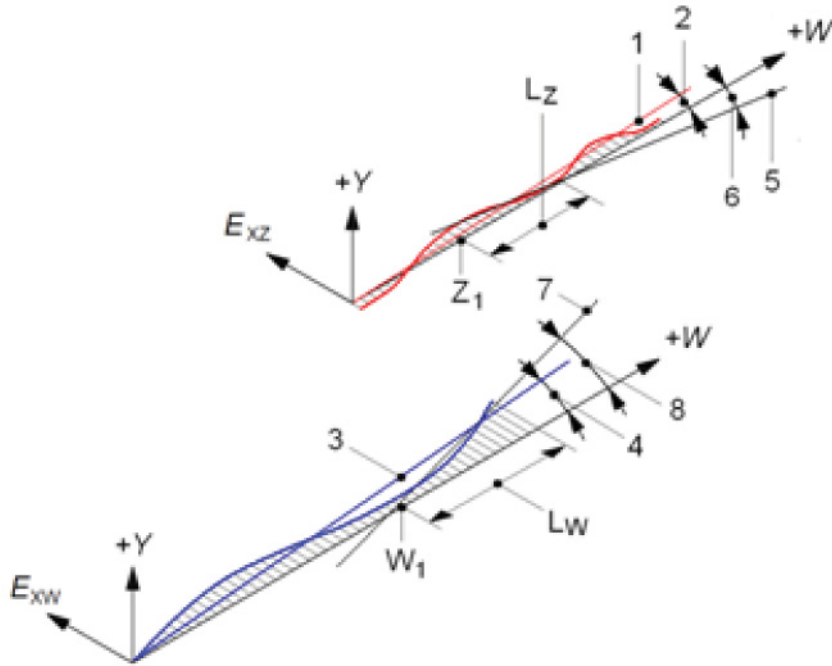

Key

- E_{XZ} Z-axis straightness deviations, measured in the ZX plane, with respect to a physical straightness reference aligned with the W-axis
- E_{XW} W-axis straightness deviations, measured in the ZX plane, with respect to a physical straightness reference aligned with the W-axis
- L_W local W-axis measurement length
- L_Z local Z-axis measurement length
- 1 reference straight line associated to E_{XZ} measurements over the full Z-axis travel
- 2 inclination of reference straight line 1; $\theta_{Z_1,ZX}$ (positive value, as shown)
- 3 reference straight line associated to E_{XW}
- 4 E_{XW} reference straight line inclination; $\theta_{W,ZX}$ (positive value, as shown)
- 5 reference straight line associated to E_{XZ} measurements over measurement length L_Z starting at Z_1
- 6 inclination of reference straight line 5; $\theta_{ZL,ZX}$ (negative value, as shown)
- 7 reference straight line associated to E_{XW} measurements over measurement length L_W starting at W_1
- 8 inclination of reference straight line 7; $\theta_{ZW,ZX}$ (positive value, as shown)

NOTE Local parallelism error: $\theta_{ZL,ZX} - \theta_{ZW,ZX}$.

Figure 32 — Evaluation of local Z-axis parallelism error with respect to the local travel of the datum W-axis

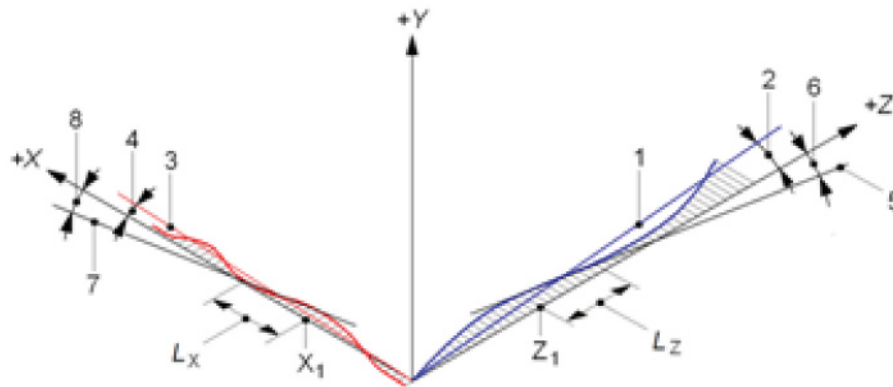

Key

- L_X local X-axis measurement length
- L_Z local Z-axis measurement length
- 1 reference straight line associated to E_{XZ} , evaluated over the full Z-axis travel
- 2 E_{XZ} reference straight line inclination; $\theta_{Z,ZX}$ (positive value, as shown)
- 3 reference straight line associated to E_{ZX} , evaluated over the full X-axis travel
- 4 E_{ZX} reference straight line inclination; $\theta_{X,ZX}$ (negative value, as shown)
- 5 reference straight line associated to E_{XZ} measurements over measurement length L_Z starting at Z_1
- 6 inclination of reference straight line 5; $\theta_{ZL,ZX}$ (negative value, as shown)
- 7 reference straight line associated to E_{ZX} measurements over measurement length L_X starting at X_1
- 8 inclination of reference straight line 7; $\theta_{XL,ZX}$ (positive value, as shown)

NOTE Local squareness error: $E_{B0X} = \theta_{X,ZX} - \theta_{ZL,ZX}$.

Figure 33 — Evaluation of local squareness error between axes of linear motion

Specification of local tolerances for parallelism error and squareness error between two axes of motion, defined over short measurement lengths, can tend to lose significance. Measurement results might be significantly bigger than the corresponding results evaluated over the entire available measurement lengths.

EXAMPLE Specification of tolerances for straightness error, parallelism error and squareness error shall consider the following three alternatives [related, for simplicity, to specification of parallelism error of Z-axis (referred axis) to W-axis (datum axis)].

- a) No specification for local tolerances.
Parallelism error of Z relative to W: full stroke of Z-axis over the full stroke of W-axis (corresponds to lines 1 and 3 in Figure 31).
- b) Specification of local tolerances for Z-axis only.
Parallelism error of Z relative to W for each 300 mm of Z: full stroke for W-axis, local measurement length of 300 mm for Z, evaluation of maximum difference over all contiguous 300 mm segments of Z (corresponds to lines 5 and 3 in Figure 31, whereas, for the evaluation, Z_1 varies from 0 to full stroke minus 300 mm);
- c) Specification of local tolerances for Z-axis and local tolerances for W-axis.
Parallelism error of Z relative to W for each 300 mm of Z and each 300 mm of W: local measurement length of 300 mm for Z-axis and for W-axis, evaluation of maximum difference over all possible 300 mm segments of Z and W (corresponds to lines 1 and 7 in Figure 32, whereas, for the evaluation, Z_1 varies from 0 to overall Z-axis stroke minus 300 mm, and W_1 varies from 0 to overall W-axis stroke minus 300 mm).

Specification of local tolerances shall primarily reflect functional requirements but due consideration shall be given to practical testing of the machine tool performances.

4.1.4 Overall or inclusive tolerances

In many cases, overall tolerances are used to limit a geometric parameter which is the resultant effect of several geometric errors. Such a parameter is determined by a single measurement, without each error being individually known or measured.

EXAMPLE The run-out of a shaft shall be taken as the sum of the out-of-roundness of the circumference in the plane “ab”, with which the stylus is in contact, the coaxiality error between the geometric axis and the axis of rotation of the shaft and the radial error motion of the spindle axis of rotation in the plane “ab” (see Figure 34).

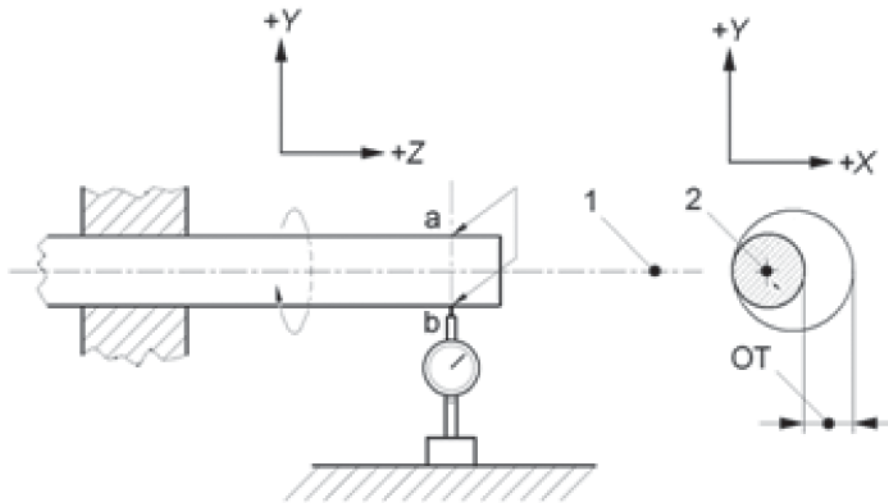

- Key**
- 1 axis average line
 - 2 geometric axis of shaft
 - ab measurement plane
 - OT overall tolerance (run-out)

Figure 34 — Overall tolerance for run-out of a rotating shaft

4.2 Tolerances applicable to machine tool functional surfaces, machine tool components and test pieces

ISO 1101 is the reference standard for tolerances applicable to machine tool components and workpiece characteristics. Such a standard shall also be applied for specification and testing of machine tool functional surfaces.

4.3 Additional limiting conditions associated with tolerances

Specific functional requirements, as well as assembling and inspection requirements, might need to be stated by adding limiting conditions to the specification of tolerance for a given geometric characteristic or accuracy parameter. Such additional limiting conditions shall be specified with plain text. Table 1 contains a non-exhaustive list of such conditions.

Table 1 — Examples of additional limiting conditions associated with tolerances

Geometric characteristic or accuracy parameter	Reference for definition	Additional limiting conditions for the corresponding tolerance
Parallelism of motions	3.6	As a rule, the direction of the error is not important; however, if the error of parallelism is to be allowed only in one direction, the direction shall be indicated, e.g. angle between motions only greater than zero.
Squareness involving axes of linear motion and/or axis of rotation average lines	3.6.7 3.6.8 3.6.9	When the squareness error is permissible in only one direction, that direction shall be indicated, e.g. angle greater than 90°.
Intersection between axis average lines	3.7.4	If one of the two axis average lines can be considered as the reference axis, then the tolerance may have additional specification e.g. axis average line 1 to be higher than (or in front of) axis average line 2.
Equidistance of axis average lines	3.7.3	If the difference is permissible in one direction only, that direction shall be specified, e.g. axis average line 1 higher than axis average line 2.
Coaxiality of axis average lines	3.7.2	In special cases, an additional indication may be given depending on operating conditions, for instance: — axis average line 1 only higher than axis average line 2, — free end of axis average line 1 directed only outwards in relation to axis average line 2.
Straightness and/or flatness of functional surfaces	ISO 1101	Additional requirement could be specified, were applicable, e.g. concave or convex (with respect to the material side).

5 Uncertainty of measurements, test methods and measuring instruments

Uncertainty of measurement should be taken into account when specifying tolerances and when evaluating conformance with specified tolerances.

When reporting the result of a measurement, a quantitative indication of the quality of the result shall be given in order to allow the comparison of measurement results, either among themselves or with specified values. Such quantitative indication is evaluated and expressed as the measurement uncertainty.

ISO/IEC Guide 98-3 contains internationally recognized procedures for the expression and the evaluation of measurement uncertainty.

ISO/TR 230-9 provides practical information for the estimation of measurement uncertainty for machine tool tests according to the ISO 230 series.

ISO 14253-2 introduces the Procedure for Uncertainty Management (PUMA). Other practical information can be found in Knapp^[7], W. Knapp *et al.*^[8] and Bell^[9].

It shall be considered that simplified testing for verification purposes does not require the preparation of a formal statement for measurement uncertainty, nevertheless good practice suggests that an uncertainty budget is made available for all most common measurements (straightness, squareness, accuracy and repeatability of positioning numerically controlled axes, etc.) with the application of the available testing procedures and measurement systems.

Proper definition of the object of the measurement (the measurand) is indispensable. No measurement shall be performed without clear understanding of what shall be measured and under what conditions.

The main contributors to the measurement uncertainty shall be taken as:

- a) the measurement uncertainty of the measuring device;
- b) the calibration uncertainty and deviations of artefacts;
- c) the application of the measuring device and the artefacts, such as misalignment and centring of the measuring device and artefacts to the machine tool axis;
- d) environmental variation errors, such as temperature influences and vibration;
- e) the repeatability of the measurement including the set up.

The following assumptions shall be made.

- The measurement device and artefacts are used according to the guidelines of the equipment supplier/manufacturer.
- The measurement device and artefacts are mounted statically and dynamically stiff and without any hysteresis (see 6.3.2).
- The machine components holding the equipment behave as rigid bodies, if not stated otherwise.
- If these assumptions are not fulfilled, additional contributors to the measurement uncertainty shall be taken into account and reported.
- For any measurement, the combined standard uncertainty [in accordance with Equation (1) of ISO/TR 230-9:2005] should be calculated and the measurement uncertainty, U , should be stated for a coverage factor k of 2 [in accordance with Equation (3) of ISO/TR 230-9:2005].
- Geometrical tests are generally performed using measuring instruments, reference artefact(s) and/or natural references (e.g. light beam, gravity). Reference artefacts are objects, such as straightedges and test mandrels.
- Inaccuracies of measurement due to the instruments, as well as to the methods used, shall be taken into account during the tests.
- The measuring instrument should not cause any error of measurement exceeding a given fraction of the tolerance to be verified. A calibration sheet should be available for each instrument. Machines under test and instrumentation should be protected from effects of external temperature variation, such as draughts and from disturbing light or heat radiation (sunlight, excessively close electric lamps, etc.), and the temperature of the measuring instruments should be stabilized before measuring.
- A given measurement should preferably be repeated, the result of the test being obtained by taking the average of the measurements. If the measurement results vary significantly, the cause should be sought either in the method or the measuring instrument, or in the machine tool itself. For more precise indications, see ISO/TR 230-11.

6 Preliminary operations

6.1 Installation of the machine before tests

6.1.1 General

The machine shall be completely assembled and fully operational in accordance with the supplier/manufacturer's instructions that shall be provided in written form. All necessary operations, geometric alignment and functional checks shall be completed satisfactorily and results be documented before starting the tests.

The machine tool should be installed on a suitable foundation subject to agreement between the supplier/manufacturer and the user. Geometric tests shall be carried out in an environment with acceptable vibration conditions. If vibration problems occur, environmental vibration values (amplitude and frequency) should be checked to satisfy the requirement of the manufacturer. The vibration test methods are specified in ISO/TR 230-8.

6.1.2 Levelling

The aim of the levelling is to obtain the condition of static stability of the machine, which facilitates subsequent measurements, especially those relative to the straightness of certain components.

Although often a convenient method for achieving straightness of motion, absolute levelling is not a requirement for machine tools (e.g. machine tools used in ships cannot be levelled, but function just like the stationary machine tools).

6.2 Conditions before machine tests

6.2.1 Disassembling of certain components

As the tests are carried out, in principle, on a completely finished machine, disassembling of certain components should only be carried out in exceptional circumstances, in accordance with the instructions of the supplier/manufacturer (e.g. disassembling of a machine table in order to check the slideways).

6.2.2 Temperature conditions of certain components before tests

The aim of the tests described in this part of ISO 230 is to evaluate the accuracy of the machine under conditions as near as possible to those of normal operation as regards lubrication and warm up. During the geometric and machining tests, components such as spindles, which are susceptible to warm up and consequently to changing position or shape, shall be brought to the proper temperature by idling the machine in accordance with the conditions of use and the instructions of the supplier/manufacturer.

In accordance with ISO 1, the reference temperature for industrial dimensional measurements is 20 °C, therefore the measuring instruments and the measured objects should be in equilibrium with the environment where the temperature is kept at 20 °C. If the environment is at a temperature other than 20 °C, Nominal Differential thermal Expansion (NDE) correction between the measurement system and the measured object (machine tool) shall be made to correct the results to correspond to 20 °C.

NOTE Special conditions can be applied to high-precision machines and some numerically controlled machines for which temperature fluctuations have a marked effect on the accuracy.

It shall be taken into consideration how much the machine alters in dimensions during a normal working cycle from ambient to working temperature. The preliminary warm-up sequence and the ambient temperature at which the machine is to be tested should be the subject of agreement between the supplier/manufacturer and the user.

Useful information on the machine tool thermal environment can be gathered from ISO 230-3:2007, Annex C.

6.2.3 Preliminary checks

Spindle speeds and feedrates may influence geometric and machining tests. Therefore, conformance of actual spindle speeds and feedrates with those commanded should be verified before conducting these tests.

6.2.4 Operating conditions

Geometric tests shall be made either when the machine is at a standstill (e.g. flatness) or when it is running under quasi-static no-load conditions. However, under special circumstances, the machine supplier/manufacturer and the user may agree that the tests be run with a specified workpiece weight.

6.3 Test setup and instrumentation

6.3.1 General

Most measurements described in this part of ISO 230 are carried out to measure error motion between the component of the machine that holds the workpiece and the component of the machine that holds the cutting tool.

The setups and instrumentation described are provided as suggestions only. Other instruments and setups capable of measuring the same quantities and having the same or smaller measurement uncertainty may be used. All software compensation used shall be stated on the test report.

Attention shall be devoted to the thermal stabilization of the instruments in accordance with the manufacturer/supplier's instructions (see ISO/TR 230-11).

All test setups normally involve two fixtures, one which establishes the reference point or surface, and the second which holds some type of sensor to read against this reference point or surface. The reference point can be the test ball or the retroreflector. The sensor can be a linearly variable differential transformer (LVDT), a capacitance gauge, an eddy current sensor, laser interferometer or a dial indicator. Before starting any of the measurements, ensure that the particular setup and instrumentation function properly within the machine tool environment. Two main tests are recommended for such checks: setup hysteresis and stability.

6.3.2 Setup hysteresis and play test

The goal of this test is to discover any effects of setup hysteresis or play, which may be caused by loose bolts in test setups, insufficient structural strength in the brackets, etc. Any hysteresis associated with the setup used for geometric accuracy measurements is normally observed as lack of repeatability in measurement results, which may erroneously be attributed to the machine's behaviour.

Hysteresis of a measurement setup is determined by applying a suitable bi-directional force, in the measurement direction, between the two fixtures and observing the resulting deflection. The sensitivity of the test result to the magnitude of such force is, in general, insignificant. The range of forces can be between 20 N and 200 N, depending upon the test setup and the resolution of the linear displacement sensor. The forces applied should not threaten damage to the machine or the metrology setups. Forces less than 40 N are recommended to avoid causing machine hysteresis. There is no need to measure forces.

The test procedure is the following.

- a) Set up and zero a displacement sensor between the two fixtures in the direction and location of the intended axis performance test.
- b) Apply a force, by hand, to the fixture holding the reference point/surface.
- c) After the force is applied, gradually decrease this force to zero and read the displacement sensor.
- d) Apply a force by hand in the opposite direction, gradually decrease the force to zero and read the displacement sensor.
- e) The difference in readings is the reference point/surface fixture hysteresis.
- f) Apply the force to the fixture holding the displacement sensor.
- g) Gradually decrease this force to zero and read the displacement sensor.
- h) Apply a force by hand in the opposite direction, gradually decrease the force to zero and read the displacement sensor.
- i) The difference in readings is the displacement sensor fixture hysteresis.

- j) The arithmetic sum of the hysteresis values for the two fixtures is the total test setup hysteresis.

Conventional practice is that the setup hysteresis be less than 10 % of the desired measurement repeatability. If significantly more than this is measured and if this hysteresis cannot be reduced by adjusting the test setup, it may be caused by the machine itself. In such cases, further testing shall be discontinued until this condition is corrected.

6.3.3 Setup stability test

Machine tools are subject to a wide variety of vibrations from both internal and external sources. These vibrations vary in both frequency and amplitude depending on time, location within the machine and machine axis positions. The stiffness and damping characteristics of machines may exclude these vibrations from having an effect on the actual performance of the machine. However, improper mounting of test equipment may also make the instrument/test sensitive to these vibrations. The setup stability test is designed to assure that the mounting of instruments does not significantly affect the uncertainty of measurements.

The test procedure is the following.

- a) Mount the measuring instrument in the manner used for the performance test.
- b) Position the machine in the middle of travel for the performance test.
- c) Set the instrument to zero and sample the output at a rate and time equal to those used in the test, without moving the machine. The range of data sampled should not exceed 10 % of the tolerance of the specified test.

7 Machine static compliance and hysteresis tests

7.1 General

These tests are designed to estimate machine static compliance and hysteresis when a static load is applied between the tool and the workpiece or between any machine components. They provide a simplified indication of what more rigorous compliance testing would measure. Compliance values vary as functions of the position of the machine tool axes and the direction of applied force. The positions should be recorded along with the test results.

The linear compliance is measured near the centre of the work zone and is measured for each linear positioning axis. Linear compliance for machines with rotary axes is measured at a radial distance from the axis average line of the rotary axis (see 7.4).

In general, the supplier/manufacturer should specify the maximum load and provide detailed instructions on fixturing construction. As the loads applied in these tests are large, appropriately designed fixturing is essential for the safety of personnel and the machine.

7.2 Tests for machine static compliance and hysteresis by applying force externally

7.2.1 General

A typical test setup is shown in Figure 35. A linear actuator and a force sensor (load cell) are rigidly fixed in series between the tool holding side of the machine (e.g. spindle) and the work holding side of the machine (e.g. table) in the direction along the linear axis to be tested. A linear displacement sensor is also set to read the relative motion generated by the actuator.

The static load may be applied using an external linear actuator, such as a differential screw or hydraulic actuator (see Figure 35). The method and the amount of applied loads may be specified in machine-specific standards and should be subject to agreement between user and supplier/manufacturer as high loads can damage the machine.

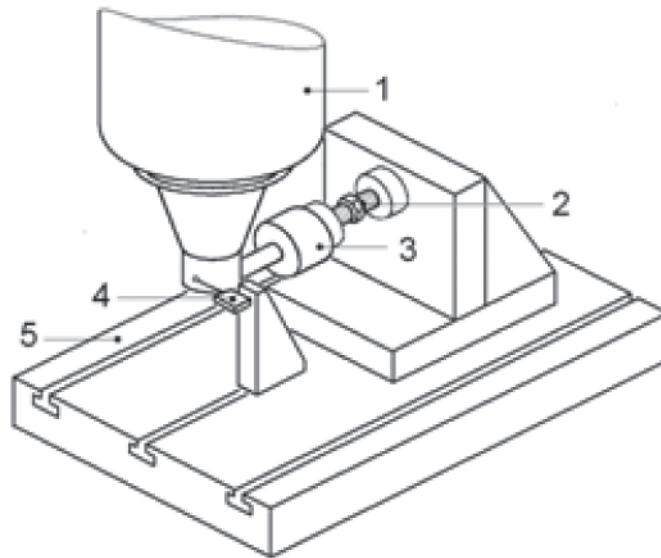

Key

- 1 spindle housing
- 2 differential screw
- 3 load cell
- 4 linear displacement sensor
- 5 machine table surface

Figure 35 — Setup for machine static compliance and hysteresis test by applying external force using a differential screw

7.2.2 Test procedure

Unless otherwise specified, the machine axes shall be positioned approximately at the centre of their respective working travels.

- a) Create a zero-force condition with the actuator and set the linear displacement sensor to zero.
- b) Exert the maximum test load (or permissible maximum deflection) using the actuator. Call this the positive direction.
- c) Record the force and displacement readings.
- d) Operate the actuator in the opposite direction until the force drops to 1 % of the maximum applied force (positive preload).
- e) Record the force and displacement readings.
- f) Continue operating the actuator in the same (negative) direction until the force (or deflection) reaches its maximum (negative) value.
- g) Record the force and displacement readings.
- h) Operate the actuator in the opposite (positive) direction until the force drops to 1 % of the maximum force (negative preload).
- i) Record the force and displacement readings.

7.2.3 Data analysis

The compliance for the axis is the total range of recording displacements divided by the total range of recorded forces, expressed in micrometres per newton ($\mu\text{m}/\text{N}$).

The machine hysteresis for the axis is computed as the range of recorded displacements between the positive preload and negative preload points, expressed in micrometres. This computation of hysteresis includes the machine compliance between $-P$ and $+P$, thus it yields a very small overestimation of hysteresis (as $-P$ and $+P$ are 1 % of the maximum applied force). This method is nevertheless preferred to the measurement of deflection at zero force, due to practical difficulty in properly applying and measuring such (nominal) zero force. Smaller preloads may be applied, where required and feasible.

The values of these computations are indicated in Figure 36.

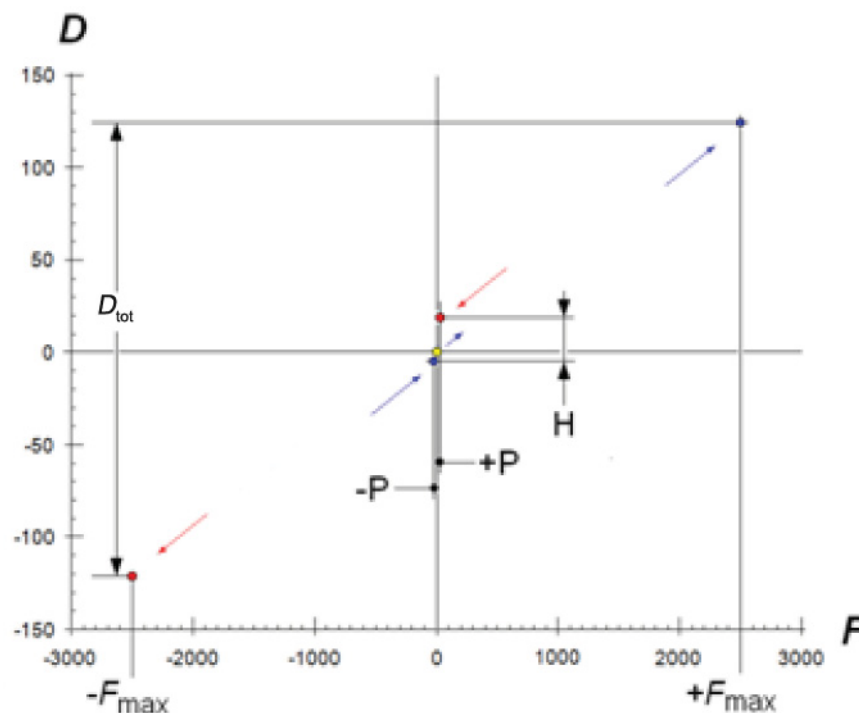

Key

F	applied force (N)
D	deflection (μm)
D_{tot}	total measured deflection
$+F_{\text{max}}$	maximum positive applied force
$-F_{\text{max}}$	maximum negative applied force
$+P$	positive preload
$-P$	negative preload
H	hysteresis

Figure 36 — Example of machine static compliance and hysteresis test results applying external force

7.3 Tests for machine static compliance and hysteresis by applying force internally

7.3.1 General

A typical setup for vertical axes is shown in Figure 37. A linear displacement sensor is set to read the relative motion between the tool holding side of the machine (e.g. spindle) and the work holding side of the machine (e.g. table) in the direction along the linear axis to be tested. A load cell is aligned with the same machine axis

and rigidly fixtured between the machine table and the spindle. The static load is generated by moving a machine axis. It is recommended that the setup be such that the load cell functions both under tension and compression. If the machine has backlash compensation, this test is conducted with the backlash compensation on. The method and the amount of generated loads may be specified in machine-specific standards and should be subject to agreement between the user and supplier/manufacturer, as high loads can damage the machine.

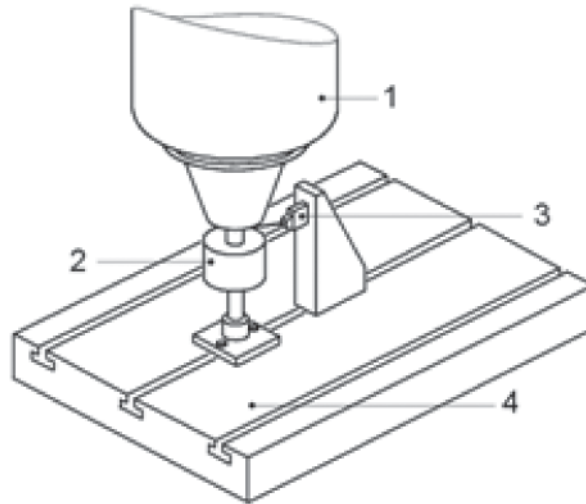

Key

- 1 spindle housing
- 2 load cell
- 3 linear displacement sensor
- 4 machine table surface

Figure 37 — Setup for machine static compliance and hysteresis test with internally applied force in the vertical direction by moving the spindle head

7.3.2 Test procedure

Performing the test in the fashion described in this subclause removes any effects due to clearance in the test fixtures or deflections of the load cell. Results obtained by the execution of this test tend to show smaller machine compliance values than the results obtained by the execution of tests with the application of external force. This test is only proposed as a possible alternative to tests specified in 7.2 when apparatus for the application of external force are not available.

Unless otherwise specified, the machine axes shall be positioned approximately at the centre of their respective working travels.

- a) Set to zero the indicator at the beginning of each test.
- b) Move the machine axis under test in small increments until the maximum force specified, or a maximum specified deflection (the difference between the actual displacement and the commanded displacement) has been reached. Call this the positive direction.
- c) Record the commanded displacement, the displacement measured by the indicator and the force.
- d) Incrementally move the axis in the opposite (negative) direction until the force drops to one percent of the maximum force (positive preload).
- e) Record the commanded displacement, the displacement measured by the indicator and the force.

- f) Continue incrementally moving in the same (negative) direction until the force (or deflection) reaches its maximum value.

NOTE For some machines, it can be inappropriate to apply force in both directions.

- g) Record the commanded displacement, the displacement measured by the indicator and the force.
- h) Incrementally move the axis back in the plus direction until the force drops to one percent of the maximum force (negative preload).
- i) Record the commanded displacement, the displacement measured by the indicator and the force.

7.3.3 Data analysis

To evaluate machine compliance and hysteresis, the deflection (actual displacement minus commanded displacement) at each measurement point is computed. The compliance in the direction of the axis is computed as the total range of the deflections divided by the total range of force (expressed in micrometres per newton [$\mu\text{m}/\text{N}$]).

The machine hysteresis for the axis is computed as the range of deflection between the positive preload and negative preload points (expressed in micrometres). This computation of hysteresis includes the machine compliance between $-P$ and $+P$, thus it yields a very small overestimation of hysteresis (as $-P$ and $+P$ are 1 % of the maximum applied force). This method is nevertheless preferred to the measurement of deflection at zero force, due to practical difficulty in properly applying and measuring such (nominal) zero force. Smaller preloads may be applied, where required and feasible. The values to be used for these computations are indicated in Figure 38.

Deflections at intermediate points can be recorded as shown in Figure 38. The data analysis yields the average compliance over the tested range.

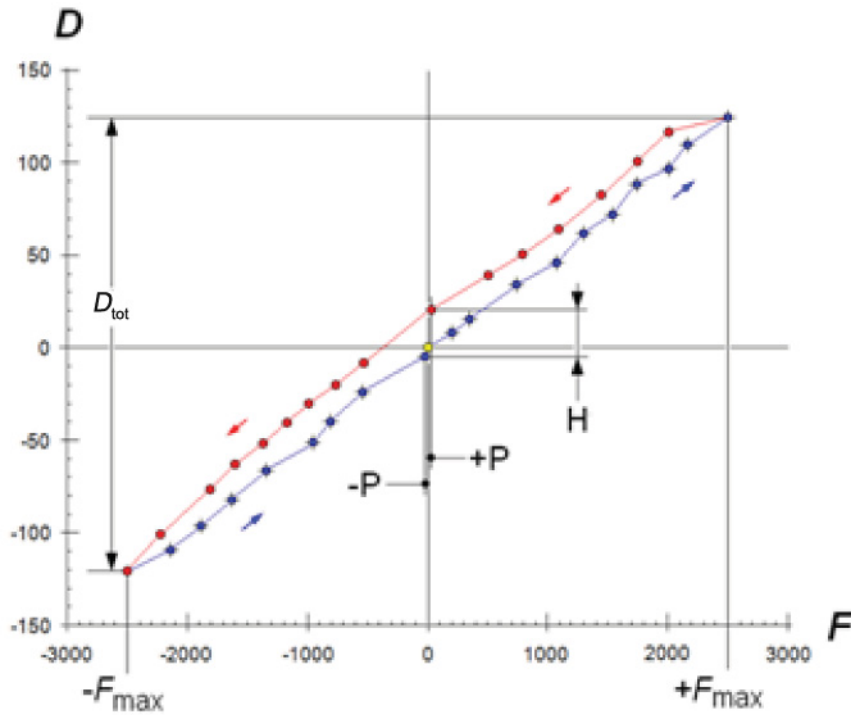

Key

F	applied force (N)
D	deflection (μm)
$+F_{\text{max}}$	maximum positive applied force
$-F_{\text{max}}$	maximum negative applied force
D_{tot}	total measured deflection
$+P$	positive preload
$-P$	negative preload
H	hysteresis

Figure 38 — Example of machine static compliance and hysteresis test results applying internal force

7.4 Tests for machines with rotary axes

The tests for machines with rotary axes are similar to the tests described in 7.2 and 7.3 except that the force is applied at a distance, R , from the axis of rotation. Correspondingly, a load cell and a linear displacement sensor are aligned with the direction of the applied force at the same distance R .

Two typical setups for measuring the compliance and hysteresis of machines with rotary axis, applying internal force, are shown in Figures 39 and 40. The procedures for data analysis are also similar to the ones described in 7.2 and 7.3. The resulting calculated compliance shall be expressed in micrometres per newton ($\mu\text{m}/\text{N}$) at a specified distance R . The hysteresis shall be expressed in micrometres (μm).

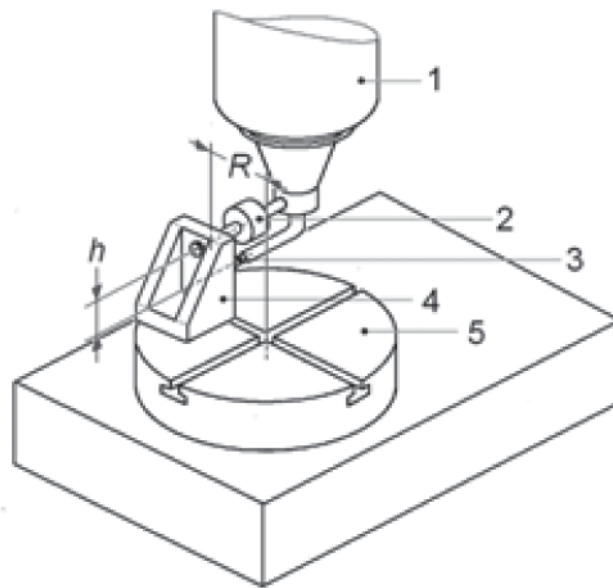

Key

- 1 spindle housing
- 2 load cell
- 3 linear displacement sensor (hidden)
- 4 bracket
- 5 rotary table
- h offset between the point of deflection measurement and the point where force is applied
- R distance between the rotary table axis average line and the point where force is applied

Figure 39 — Setup for static machine compliance and hysteresis test for machines equipped with rotary axis applying internal force (horizontally)

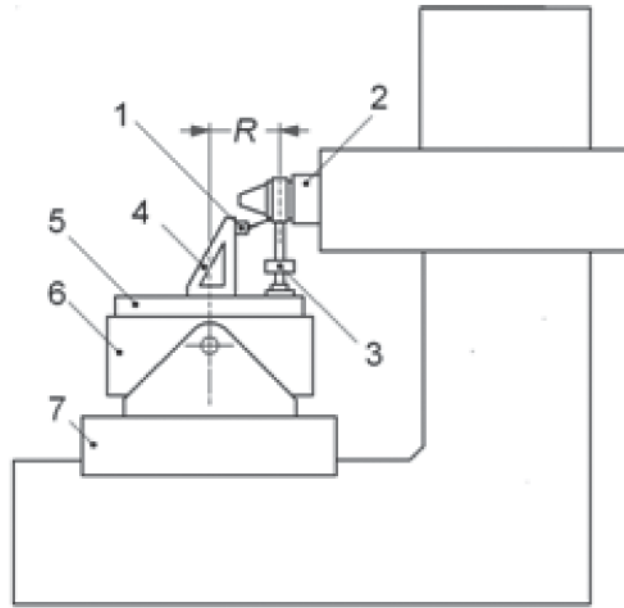

Key

- 1 linear displacement sensor
- 2 spindle housing
- 3 load cell
- 4 bracket
- 5 rotary table
- 6 tilting table
- 7 linear displacement table
- R distance between the tilting table axis average line and the point where force is applied

Figure 40 — Setup for static machine compliance and hysteresis test for machines equipped with tilting rotary table applying internal force (vertically)

8 Geometric accuracy tests of axes of linear motion

8.1 General

All machine tools are composed of moving carriages, tables, or other elements whose purpose is to change, under manual or automatic control, the relative position between the workpiece and the cutting tool. Assuming it has rigid body behaviour (no deformation due to loads), a typical linear carriage exhibits six error motions associated with its nominal linear motion (see 3.4.3):

- a) one linear displacement (positioning) error motion along the intended direction of travel;
- b) two straightness error motions in the two orthogonal directions to the direction of travel;
- c) three angular error motions, which are rotations around the three orthogonal axes (X-, Y- and Z-axes).

Among these, straightness and angular errors are considered pure geometric errors, whereas the linear displacement (positioning) errors are a function of both geometry and the axis drive system characteristics. Linear displacement (positioning) error measurements for numerically-controlled axes are covered separately in ISO 230-2.

Dependent on machine configuration, some error motions have reduced relevance as they do not cause errors in a sensitive direction (e.g. for a turning centre without live tooling, straightness error of Z in Y direction is not necessarily of primary concern).

8.2 Straightness error motion tests

8.2.1 General

The straightness error motions of a machine tool component moving on a linear trajectory directly influence the straightness and flatness of surfaces as well as the form, location and orientation of geometric features of the workpiece produced by the machine tool.

The straightness error motion measurement methods are based on the measurement of displacement relative to a straightness reference. Straightness reference can be a physical artefact (straightedge, taut-wire) or reference lines provided by a light beam of an optical device. A straightness reference shall be placed approximately parallel to the direction of motion of the moving component (similar readings at both ends of the travel). The measuring instrument provides deviations of the distance between the straightness reference and the trajectory of motion (straightness deviations) at various points (uniformly distributed or random) over the entire measurement length. The relative deviations between the tool holding side of the machine and the workpiece holding side of the machine shall be measured.

NOTE Measurement of straightness error motion is affected by the location of the line of measurement due to the inherent angular error motions of the slides and Bryan^[10] offsets involved (see Figure 41). Therefore, similar tests for the same motion carried out at different locations can have different results. In Figure 41, the effect of one angular error motion α is given as $e = \sin(\alpha) \cdot L$, where L is the offset length.

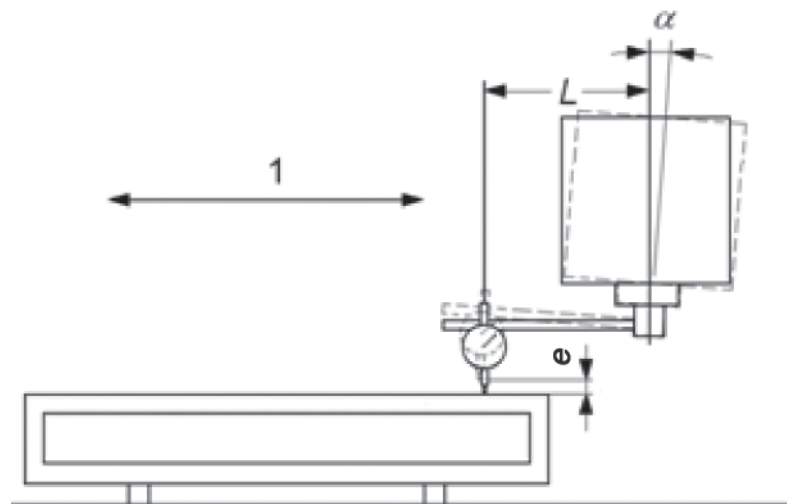

Key

- 1 linear motion
- e deviation due to angular error motion and the offset
- L offset length
- α angular error motion

Figure 41 — Effect of one angular error motion on straightness measurements

8.2.2 Measurement setups and instrumentation

8.2.2.1 Straightedge and a linear displacement sensor

In this setup, the straightness reference is a straightedge. This setup can address straightness deviations in vertical and horizontal directions. For measurements of straightness deviations in vertical direction, the straightedge should be supported at the two points that yield a minimum deflection due to gravity (for optimum support, see ISO/TR 230-11).

The linear displacement sensor shall be located as close to the functional point of the moving component as possible. The measurement shall be made by moving the linear displacement sensor along the straightedge (or by moving the straightedge) and by recording the observed displacements [see Figure 42 a)].

Known errors of the straightedge should be taken into account, in processing the measurement data. If the straightedge errors are not known, they can be determined and removed from the straightness error motion measurements in the horizontal plane using the straightedge reversal method described in 8.2.2.1.1.

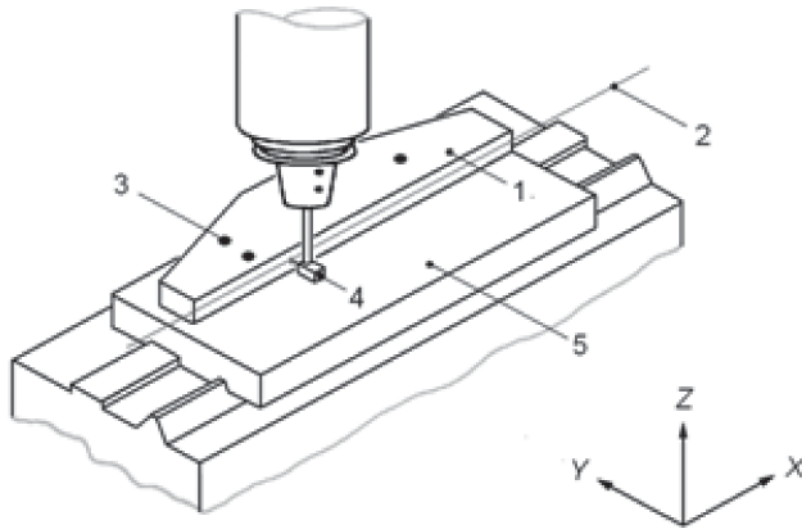

a) Normal setup

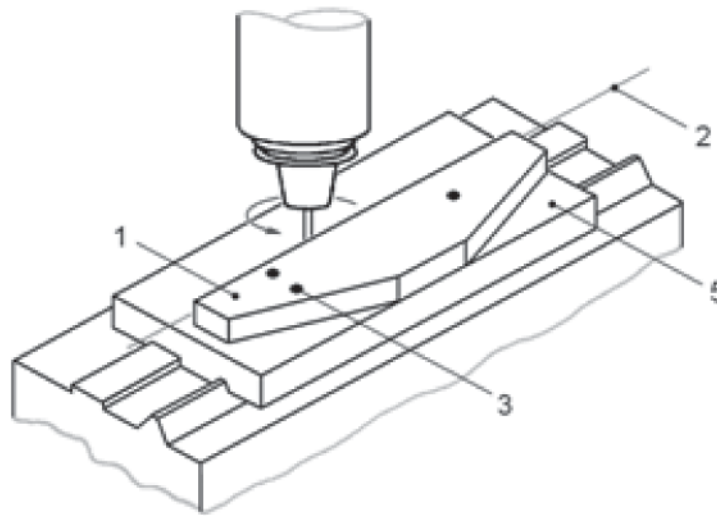

b) Reversed setup

Key

- 1 straightedge
- 2 measurement line
- 3 straightedge support points (3) both sides
- 4 linear displacement sensor
- 5 machine table

Figure 42 — Straightness measurement setup using straightedge

8.2.2.1.1 Straightedge reversal method for measurement of straightness error motion

A feature of the straightedge method for straightness measurement in a horizontal plane is that it allows measurement of straightness errors of both the straightedge reference face and the linear motion to be checked (see Figures 42 and 43).

For this purpose, the so-called “reversal method” is used: After the first set of measurements is recorded for the normal setup [see Figure 42 a) and see plot, E_1 , in Figure 43], the straightedge is rotated 180° about its longitudinal axis and the linear displacement sensor is also reversed to read the displacement against the same reference surface of the straightedge [see Figure 42 b)]. Measurements are then repeated, moving the machine slide and recording the displacements (see plot E_2 in Figure 43).

Both deviation plots, E_1 and E_2 , are influenced by the straightness error of the straightedge reference face and the straightness error motion of the linear axis. However, due to the special configuration of the two setups, it is algebraically possible to separate these influences. In Figure 43, the average plot, M , represents the deviations of the reference face of the straightedge.

Equations (9) and (10) apply:

$$M(X) = \frac{[E_1(X) + E_2(X)]}{2} \quad (9)$$

$$S(X) = \frac{[E_1(X) - E_2(X)]}{2} \quad (10)$$

where

$M(X)$ is the straightness deviation of the reference surface of the straightedge at a given measurement position X ;

$S(X)$ is the straightness deviation of the axis of motion at a given measurement position X ;

$E_1(X)$ and $E_2(X)$ are the measurement data obtained from normal and reversed setups.

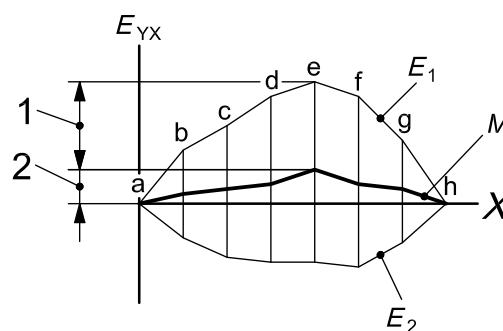

Key

- X X-axis positions
- E_{YX} straightness deviations of X in Y -axis direction
- 1 straightness error of X in Y -axis direction [$S(X)_{\max}$]
- 2 straightness error of the straightedge
- a to h measurement positions
- E_1 plot of readings from normal setup
- E_2 plot of readings from reverse setup
- M mean of E_1 and E_2

Figure 43 — Determination of the straightness error of the linear axis and of the straightness error of the straightedge with reversal method

8.2.2.2 Microscope and taut wire

A steel wire, with a diameter of approximately 0,1 mm, is stretched to be approximately parallel to the direction of motion to be checked (see Figure 44). The trajectory of the motion in the horizontal plane with respect to the taut wire is measured with a microscope [or with other means, such as a non-contacting linear displacement sensor or a photoelectric device, such as a charge-coupled device (CCD) camera] mounted to the machine spindle (see ISO/TR 230-11).

Taut wires are often used as the preferred reference straightness artefact for measuring the straightness deviation in the horizontal plane on large machines.

With a microscope placed horizontally, it is possible to measure the straightness error motion in a vertical plane when the sag of the wire is known at each point, but this sag is extremely difficult to determine with adequate accuracy. Therefore, in general, it is not recommended to use taut-wire setup for straightness error motion measurements in a vertical plane.

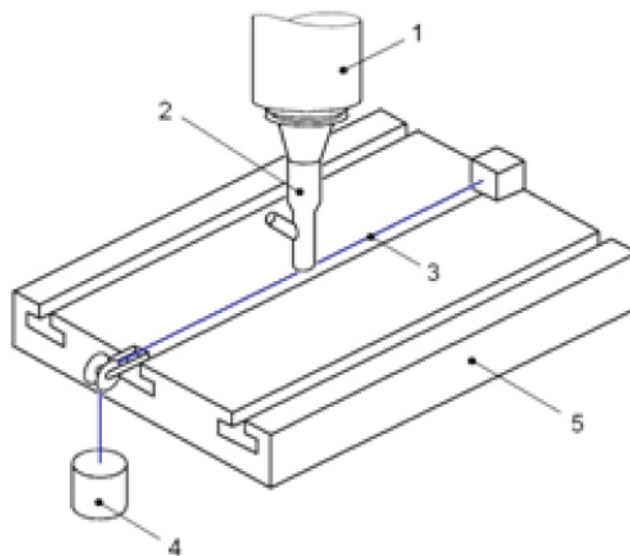

Key

- 1 spindle
- 2 microscope
- 3 taut wire
- 4 weight
- 5 table

Figure 44 — Straightness error measurement using taut wire and microscope

8.2.2.3 Alignment telescope

When using an alignment telescope (see Figure 45), the optical axis of the telescope constitutes the straightness reference. Measurements shall be conducted to represent the relative position between the tool and the workpiece. The telescope shall be mounted on the component that carries the workpiece and the target shall be mounted on the component that carries the tool. The target shall be normal to the axis of motion to be checked. The centre of the target shall be situated as near to the functional point as possible (see ISO/TR 230-11). The distance between the optical axis of the telescope and the centre of the target shall be read directly on the reticule or by means of the optical micrometer (see ISO/TR 230-11).

The telescope optical axis shall be adjusted to be reasonably parallel to the axis of linear motion trajectory.

Any local bending causes the optical line of the telescope to change its position. The results obtained in such cases do not reflect the straightness one would obtain on a machined part fixtured at multiple points over the table surface. This situation can be partially rectified by mounting the telescope to a secondary surface, which is kinematically supported over the table. Extreme care shall be taken in the fixing of the telescope, particularly in situations where table bending is suspected. Best results can be obtained by securely fixing the telescope to a support simulating a (rigid) workpiece connected to the table.

NOTE 1 In the case of long travel lengths, measurement uncertainty is affected by the variation of the refractive index of air, which strongly contributes to the deflection of the light beam, which deviates from a straight line by about 46 μm in 10 m of travel in a vertical temperature gradient of 1 $^{\circ}\text{C}/\text{m}$ (see W.T. Estler *et al.*^[11]). For best results, mixing the ambient air around the laser beam with fans can be considered, in addition to averaging with an adequate number of measurement repetitions.

NOTE 2 By rotating the entire telescope and the target, it is possible to check the straightness of a line in any plane.

NOTE 3 Some alignment telescopes can simultaneously detect displacements in two orthogonal directions. In such cases, it is possible to measure straightness in two orthogonal planes.

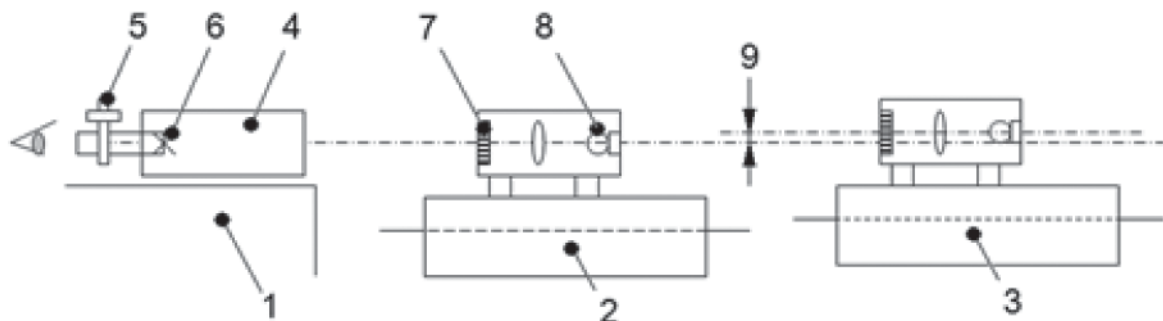

Key

- 1 workpiece side (table)
- 2 tool side (position 1)
- 3 tool side (position 2)
- 4 telescope
- 5 reading micrometer
- 6 reticle
- 7 target
- 8 light source
- 9 measured deviation

Figure 45 — Straightness error measurement using alignment telescope

8.2.2.4 Alignment laser

When using an alignment laser, a laser beam is the straightness reference of measurement. Measurements shall be conducted to represent the relative position between the tool and the workpiece. The laser head shall be mounted on the component that carries the workpiece and the four-quadrant photo-diode target shall be mounted on the component that carries the tool. The centre of the detector shall be situated as near to the functional point as possible (see ISO/TR 230-11). Horizontal and vertical deviations of the detector centre with respect to the beam shall be recorded.

Any local bending causes the optical line of the alignment laser to change its position. The results obtained in such cases do not reflect the straightness one would obtain on a machined part fixtured at multiple points over the table surface. This situation can be partially rectified by mounting the alignment laser to a secondary surface, which is kinematically supported over the table. Extreme care shall be taken in the fixing of the alignment laser, particularly in situations where table bending is suspected. Best results can be obtained by securely fixing the alignment laser on a support simulating a (rigid) workpiece connected to the table.

The measuring instrument manufacturer's instructions should be consulted (see ISO/TR 230-11).

NOTE In the case of long travel lengths, measurement uncertainty is affected by the spatial variation of the refractive index of air, which strongly contributes to the deflection of the light beam, which deviates from a straight line by about 46 µm in 10 m of travel in a vertical temperature gradient of 1 °C/m (see W.T. Estler *et al.*^[11]). For best results, mixing the ambient air around the laser beam with fans can be considered, in addition to averaging with an adequate number of measurement repetitions.

8.2.2.5 Laser straightness interferometer

The most commonly used laser straightness interferometers consist of a Wollaston prism and bi-mirror straightness reflector. The centreline of the bi-mirror reflector defines the straightness reference of measurement. Changes in the position of the Wollaston prism relative to the axis of symmetry (centreline) of the bi-mirror reflector are detected by interferometry.

Measurements shall be conducted to represent the relative position between the tool and the workpiece. The bi-mirror reflector shall be mounted on the component that carries the workpiece and the Wollaston prism shall be mounted on the component that carries the tool. Optical components and measuring methods vary and manufacturers' instructions should be applied (see ISO/TR 230-11 and ISO/IEC Guide 99).

Any local bending causes the centreline of the reflector to change its position. The results obtained in such cases do not reflect the straightness one would obtain on a machined part securely fixed at multiple points over the table surface. This situation can be partially rectified by mounting the reflector to a secondary surface, which is kinematically supported over the table. Extreme care shall be taken in the fixing of a bi-mirror reflector, particularly in situations where table bending is suspected. Best results can be obtained by fixing the bi-mirror reflector on a support simulating a (rigid) workpiece connected to the table.

All optical instruments, e.g. laser straightness interferometers, alignment telescopes, are sensitive to changes in the properties of the air. Drift tests before the measurements are recommended (see ISO/TR 230-11 and ISO/IEC Guide 99).

8.2.3 Measurement procedure and data analysis

The machine component, motion of which is to be tested, shall be moved to a series of target positions over its travel range of interest. The measuring intervals shall be no larger than 25 mm for axes of 250 mm or less. For longer axes the interval shall be no more than 1/10 of the axis length. At a target position, the machine shall remain at rest long enough for the measurement data to be recorded.

The measurement may be carried out in continuous mode (on the fly) dependent on the measuring equipment used and the intended use of the machine tool.

The default traverse speed shall be at a feedrate to suit the measuring equipment and setup being used and/or the intended use of the machine tool.

Data shall be analysed based on the definitions given in 3.4.9 and 3.4.10. A graphical presentation of results is preferred.

Test data recorded shall include the date, time, machine, instrument used, location of measuring line, offsets to the workpiece side (coordinates of the start and end point), offsets to the tool side, analysis method (definition of reference line, number of runs, mean values), mode of operation (continuous or intermittent), dwell time, feedrate, position of axes not under test, compensations used, sign convention used and the feed direction.

8.3 Linear positioning error motion tests

8.3.1 General

The displacement measuring instrument shall be set so as to measure the distance traversed by the machine component (slide) under test (corresponding to the relative motion between the tool and the work sides of the

machine). The slide shall be positioned at each target position manually or by numerical control. Each measured position value is recorded and the difference between the target position value and measured value is calculated as linear positioning deviation (see ISO 230-2).

NOTE Measurement of linear positioning error motion is affected by the location of the line of measurement due to the inherent angular error motions of the slides and the Abbe offsets involved. Therefore, similar tests for the same motion carried out at different locations can have different results.

8.3.2 Measurement setup and instrumentation

8.3.2.1 Laser interferometer

For linear positioning error motion measurement with laser interferometer, two pieces of optics are used: the retroreflector and the interferometer. One of these is mounted on the tool holding side; the other is mounted on the workpiece holding side of the machine tool. The laser beam emitted from a laser head shall be parallel to the linear motion as much as possible as misalignment causes cosine error. All optics shall be securely fixed to the machine component to avoid vibrations and deflections due to acceleration.

Air sensors (measuring air temperature, pressure and humidity) shall be located near the beam path to compensate for air refraction.

Material temperature sensor(s) (to correct the laser readings for material thermal expansion) shall be attached to the suitable machine surface indicating representative machine temperature. In common practice, the coefficient of linear thermal expansion of the most significant material that composes the machine structural loop between the tool side and the work holding side is considered, and temperature sensors are set to measure the machine temperatures close to where the workpiece is normally located (e.g. the machine table or the work holding pallet). Nevertheless, if the ambient temperature differs from 20 °C and the workpiece linear thermal expansion coefficient differs from the material composing the machine structural loop, the accuracy of the machined part is affected. Consideration should be taken of the fact that the numerical control positioning system responds to the machine feedback transducers temperature, not to the machine (table) temperature; thus, when significant spatial temperature gradients are present, further contributors to uncertainty in the estimation of the expected machined part accuracy shall be considered.

8.3.2.2 Linear scale

For linear positioning error motion measurement with linear scale, the scale and its reader are mounted on the tool holding and workpiece holding sides of the machine. The scale shall be set parallel to the linear motion as much as possible as misalignment causes cosine error. Nominal differential expansion (NDE) corrections between the reference linear scale and the machine shall be applied (see 6.2.2 and 8.3.2.1).

8.3.3 Measurement procedure and data analysis

8.3.3.1 Measurement procedures and data analysis of numerically controlled axes shall be conducted in accordance with ISO 230-2.

8.3.3.2 Periodic linear positioning error motion

Positioning error motion of a machine slide is periodic over an interval that normally coincides with the natural periodicity of the machine scales or their equivalent. For example, in a leadscrew driven machine with angular encoders, the periodicity is usually synchronous with the pitch of the leadscrew (or synchronous with the pitch of the angular encoder or both). For a linear scale or angular encoder, it is the line spacing of the scale or encoder. For laser interferometer position scale, it is the wavelength of light or fraction thereof.

A set of at least 21 evenly spaced target positions is selected over two periods of the expected periodic deviation. One unidirectional measurement is made at all the target positions. The periodic linear positioning error, P , is the total range of the measured positioning deviations as shown in Figure 46.

NOTE Sometimes the periodicity of the linear motion is due to ballscrew misalignment, creating one per revolution angular motion.

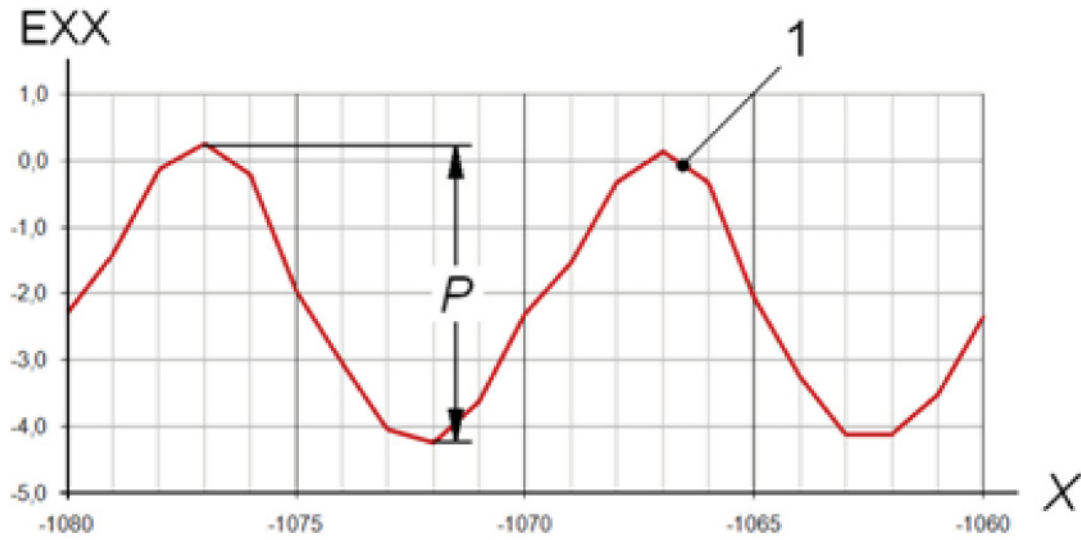

- Key**
- X X-axis position (mm)
 - E_{XX} linear positioning error (μm)
 - 1 measured deviations plot
 - P periodic linear positioning error

Figure 46 — Periodic linear positioning error

8.4 Angular error motions tests

8.4.1 General

For each linear axis of motion three angular error motions about the orthogonal directions (commonly called roll, pitch and yaw) should be measured. The angle measuring instrument shall be set as to measure relative angular error motion between the tool holding side of the machine and the work holding side of the machine as a machine component (slide) moves along its linear axis of motion.

8.4.2 Measurement setup and instrumentation

The common methods of angular error motion measurements use laser angular interferometers or autocollimators to measure pitch and yaw of an axis (rotations about axes orthogonal to the direction of the axis of linear motion), and precision levels to measure roll (rotation about the axis of linear motion) of horizontal axes. Differential straightness measurements are used to assess the roll of vertical axes (see 8.4.2.4).

NOTE When the linear movement is in a horizontal plane, a precision level can measure the pitch and roll, whereas an autocollimator and laser can measure the pitch and yaw.

8.4.2.1 Precision level

When using a precision level, the instrument shall be attached to the moving component. For good practice, differential measurements between the component of the machine holding the tool and the component holding the workpiece should be carried out using two precision levels (see Figure 47).

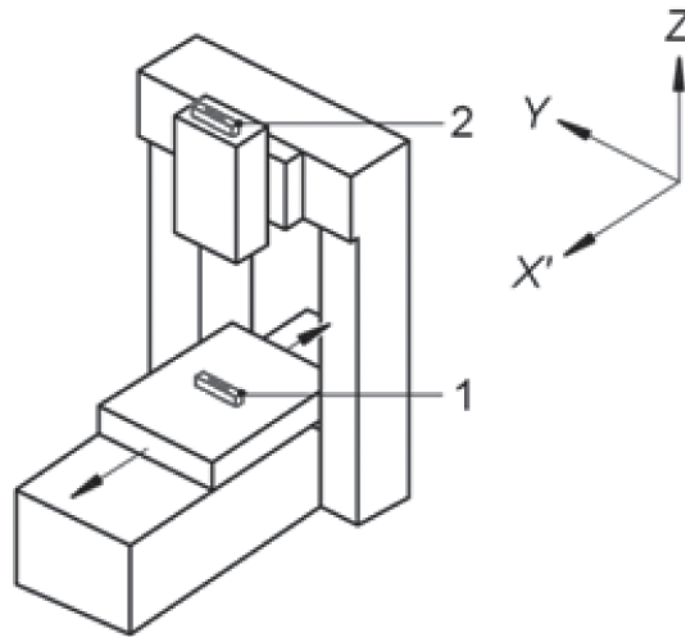

Key

- 1 measuring precision level
- 2 reference precision level

Figure 47 — X'-axis angular error motion (roll) measurement with precision levels

8.4.2.2 Autocollimator

The autocollimator and the target mirror shall be mounted for relative measurement between the workpiece holding side and the tool holding side of the machine. The autocollimator shall be mounted on the stationary component of the machine, coaxially to the axis of motion (see Figure 48). A rotation of the target mirror (mounted on the moving component) around a horizontal axis, orthogonal to the optical axis, entails a vertical displacement of the image of the reticule in the focal plane. The measurement of this displacement, which is made with the ocular micrometer, allows determining the angular deviation of the mirror (see ISO/TR 230-11). By rotating the ocular micrometer through 90°, the rotation angle of the target mirror around a vertical axis can also be measured. Instruments capable of measuring both angles simultaneously are available.

Photoelectric autocollimator can be used for more critical measurements requiring a resolution of less than 1". Some of them can measure two axes simultaneously so that angles around two orthogonal axes (e.g. pitch and yaw) can be detected and analysed easily.

NOTE In the case of long travel lengths, measurement uncertainty is affected by the variation of the refractive index of air, which strongly contributes to the deflection of the light beam, which deviates by about 9 µrad in 10 m of travel in a vertical temperature gradient of 1 °C/m (see W.T. Estler *et al.*^[11]). For best results, mixing the ambient air around the laser beam with fans can be considered, in addition to averaging with an adequate number of measurement repetitions.

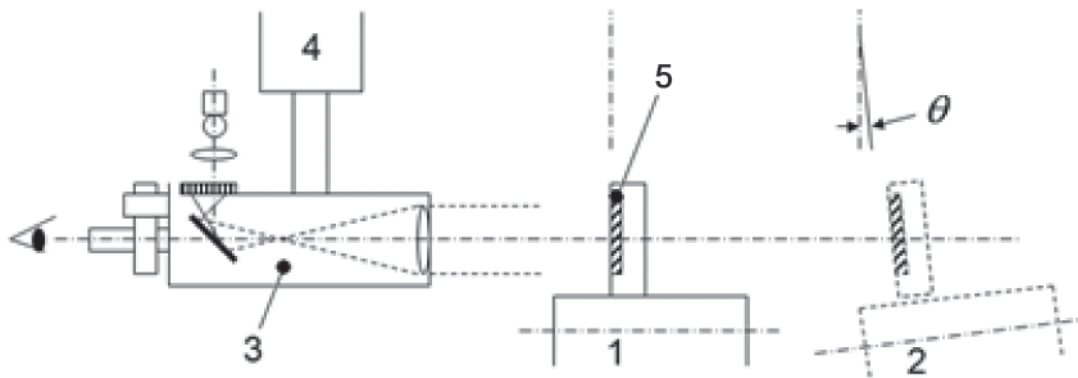

- Key**
- 1 table (workpiece side, position 1)
 - 2 table (workpiece side, position 2)
 - 3 autocollimator
 - 4 machine spindle (tool side)
 - 5 target mirror
 - θ measured angular deviation

Figure 48 — Angular error motion measurement using autocollimator

8.4.2.3 Laser angle interferometer

The laser angle interferometer is used for measuring rotations around the axes orthogonal to the axis of motion (i.e. pitch and yaw). The instrument consists of two pieces of optics: angle interferometer and dual retroreflector. When measuring the angular error of the axis of motion of a machine slide, one optic is mounted on the tool holding side and the other optic is mounted on the workpiece holding side of the machine (see Figure 49). On machines where the spindle cannot be locked, external brackets or other suitable fixtures should be used to prevent instability.

NOTE 1 The angle interferometer provides two parallel beams separated by a known distance. The dual retroreflector returns each beam back to the interferometer. The relative rotation between the interferometer and the dual retroreflector causes a path difference between the two beams, which is detected by the interferometer. Angle of rotation is determined by the path difference divided by the distance between the beam paths.

NOTE 2 By rotating the optics 90° about the beam axis, the other angular error (yaw or pitch) can be measured.

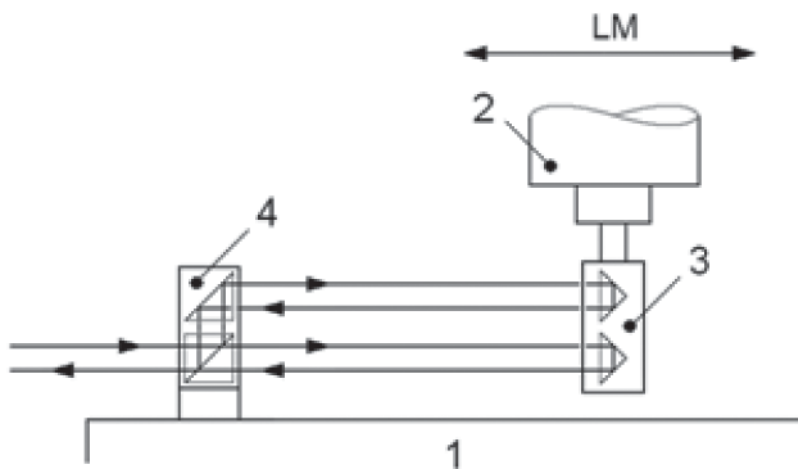

- Key**
- 1 table
 - 2 spindle
 - 3 dual retroreflector
 - 4 interferometer with bending mirror
 - LM linear motion direction

Figure 49 — Angular error motion measurement using laser angle interferometer

8.4.2.4 Method using differential straightness measurements

This measurement is performed by carrying out two parallel sets of straightness measurements. The principle is illustrated in Figure 50, which shows the setup for measuring the roll of a vertical moving spindle using a mechanical square and one or two linear displacement sensors and is applicable to any vertical moving slide. Different straightness measuring instruments may be substituted.

The instrumentation is set to measure straightness perpendicular to the line of motion of the slide. The slide is moved along its axis normal to the direction of the straightness measurement and straightness data are recorded. The displacement sensor is next mounted on an extension and the straightness is re-measured. The machine spindle is then traversed horizontally to position 2 (see Figure 50) and the linear displacement sensor is mounted on an extension arm (Key item 5) to again contact the square measurement surface and the measuring procedure is repeated, being careful to follow the same measurement line along the mechanical square reference face. The roll deviation in any particular vertical position is the difference between the two measured local straightness deviation values at that position, divided by the distance between the two spindle positions.

Because it is necessary to move one machine slide (either table or spindle) in order to accommodate the extension fixture in a direction other than the vertical during this measurement procedure, the roll measurement of the vertical axis shall be corrected for the change in angular orientation of the table or spindle caused by this motion. To avoid this potential problem, the square can be moved laterally (e.g. to the spindle position 2 in Figure 50) and readjusted using a precision level.

8.4.3 Measurement procedure and data analysis

- a) The machine shall be programmed to move the machine slide under test and to position it at a series of target positions.
- b) At a target position, the machine remains at rest long enough for the angular deviation data to be recorded. The target positions are required over the travel range of interest of the axis. The measuring intervals shall be no larger than 25 mm for axes of 250 mm or less. For longer axes, the interval shall be no more than 1/10 of the axis length.
- c) At least one set of unidirectional measurements is made at all the target positions. The traverse speed shall be agreed by the user and the manufacturer/supplier. A set of measurements shall consist of the target positions and the corresponding instrument readings.

The angular error (e.g. E_{AX}) is the total range of the measured angular deviations. Sign convention for angular deviation shall be in accordance with ISO 841.

Instead of discrete measurements at selected target positions, continuous measurements within the measurement range are allowed.

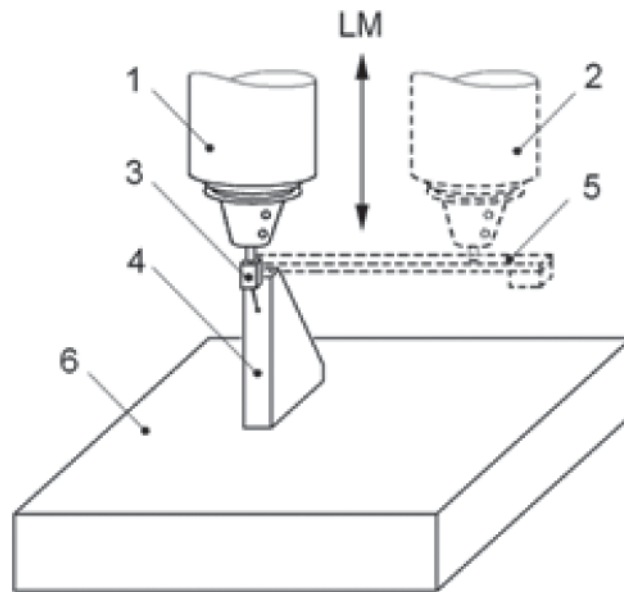

Key

- 1 spindle (position 1)
- 2 spindle (position 2)
- 3 linear displacement sensor
- 4 square (or straightedge mounted approximately square to machine table)
- 5 counter-weighted offset bracket (for spindle position 2 only)
- 6 table
- LM linear motion direction

Figure 50 — Measurement of roll of vertical moving slide using differential straightness measurements

9 Geometric accuracy tests of axes of rotation

9.1 Reference to ISO 230-7

The tests to characterize geometric accuracy of axes of rotation [i.e. radial, axial, tilt and face error motions (see 3.5.5 to 3.5.8), their synchronous and asynchronous components as well as structural motion] for fixed and rotating sensitive directions shall be performed in accordance with ISO 230-7.

9.2 Angular positioning error motion

9.2.1 General

Many machine tools are equipped with rotary axes with continuous or discrete positioning capabilities (e.g. rotary tables, indexing tables, tilting heads and swivelling heads). While the rotary axes with continuous positioning capability operate under numerical control (NC), the rotary axes with discrete positioning capability may operate under various types of control including manual, mechanical, NC or Programmable Logic Controller (PLC). The positioning resolution for the rotary axes with continuous positioning capability depends on the angular position feedback device and the servo control system. For the rotary axes with discrete positioning capability, the positioning resolution (increment) depends on the mechanical means of indexing and may vary from 90° (for some milling and boring machines tables) to 0,5°. In some applications, the combination of two angular indexing devices with different indexing pitch, allow to obtain minimum indexing steps as small as 0,02°.

Programmable indexing devices typically need an axial movement of several millimetres to unlock and allow for relative movement between their components. After indexing, such devices are locked in position.

The measurements should be carried out between the tool holding side of the machine and the workpiece holding side of the machine.

9.2.2 Measurement setup and instrumentation

9.2.2.1 Polygon with autocollimator

An optical polygon, as the reference angle artefact, should be mounted approximately concentrically to the rotating machine component in order to be measurable with the autocollimator. Mating surface of the reference and rotating component should be parallel to each other and orthogonal to the axis average line of the rotating component under test. An autocollimator shall be mounted on the non-rotating part of the machine, e.g. the machine spindle head (see Figure 51).

NOTE The average parallelism error between the polygon reference surfaces and the axis average line of the component under test influences the angular positioning measurements (inducing an additional periodic error with a 360° period).

The angular positioning increments of the rotating component under test should be the same as, or the integer multiples of, the angle between the reference surfaces of the artefact. For example, if an optical polygon with 12 faces is used as a reference artefact, each angular positioning increment is 30° or an integer multiple of 30°. The zero position (0°) should be used as the starting position in order to be able to compensate for the polygon errors recorded on its calibration chart. The angle measured by the autocollimator at each increment is the angular positioning deviation at that angular position.

Autocollimator with polygon may be used for measuring the angular positioning error of indexing rotary axes provided the available angles on the reference artefact are integer multiples of the minimum indexing increment of the indexing rotary axis under test.

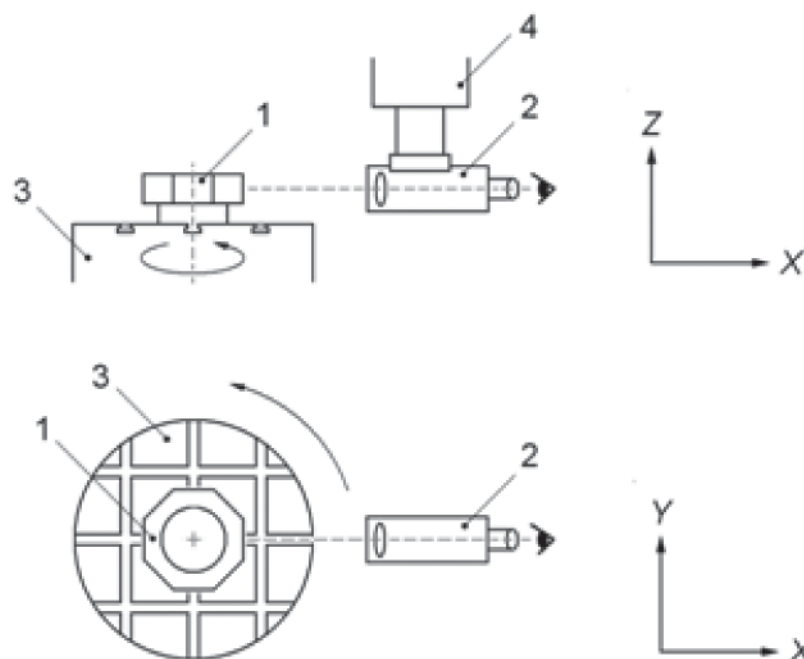

Key

- 1 polygon mirror
- 2 autocollimator
- 3 rotary table
- 4 spindle head

Figure 51 — Angular positioning error motion measurement setup using autocollimator and polygon

9.2.2.2 Reference indexing table with laser interferometer/autocollimator

The reference indexing table shall be fixed on the rotating component of the machine (e.g. rotary table). A flat reflection mirror or angular optics shall be fixed on to the reference indexing table and its surface shall be perpendicular to the light beam. A laser interferometer/autocollimator shall be fixed on the non-rotating part of the machine (see Figure 52). The reference indexing table should rotate in the direction opposite to the direction of rotation of the rotating component, i.e. if the rotating component rotates clockwise (CW), the reference indexing table should rotate counterclockwise (anticlockwise) (CCW), so that the reflection mirror (or angular optics) placed on the top surface of the reference indexing table always keeps the same orientation. The angle measured by the instrument at each increment is the angular positioning deviation at that angular position.

Autocollimator with reference indexing table may be used for measuring the angular positioning error of indexing rotary axes provided the available angles on the reference indexing table are integer multiples of the minimum indexing increment of the indexing rotary axis under test.

If the laser interferometer is used as an angle measuring instrument, it is possible to detect the angular error motions nearly up to 5° (or more than the minimum indexing angle of the master index). Therefore, continuous angular positioning error motion can be measured using this method. Generally, measurement uncertainty increases significantly if angles larger than 100 μm/m (20") are measured.

Indexing rotary axes typically need an axial movement of several millimetres to unlock and allow for relative movement between their components; when testing such devices, using laser angle interferometers with reference indexing table and angular optics, special devices may be required to prevent interruption of the laser beam.

9.2.2.3 Reference rotary (angle) encoder

The reference (calibrated) rotary encoder shall be mounted such that the rotating component of the encoder is aligned with the axis of rotation of the rotating component of the machine. The encoder case (non-rotating component) shall be attached to the non-rotating part of the machine. The instrument manufacturer's recommendations for mounting and alignment shall be followed. The encoder reading provides the actual angular displacement, which should be compared to the commanded displacement to determine angular positioning deviations.

Reference rotary (angle) encoders shall not be used to measure the angular positioning error of indexing tables that need axial movement to operate.

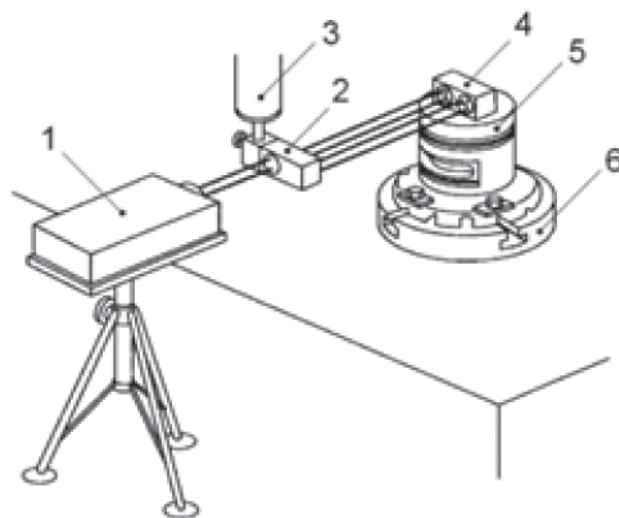

- Key**
- | | |
|--|----------------------------|
| 1 laser head | 4 dual retroreflector |
| 2 angle interferometer with bending mirror | 5 reference indexing table |
| 3 spindle head | 6 rotary axis under test |

Figure 52 — Angular positioning error motion measurement using reference indexing table

9.2.3 Test procedures and data analysis

Test procedures for the determination of angular positioning accuracy and repeatability of rotary axes with continuous positioning capability through numerical control (NC) are specified in ISO 230-2.

Test procedures specified in ISO 230-2 are also applicable for the determination of angular positioning accuracy and repeatability of rotary axes with discrete positioning capability (programmable or manually operated), but the following limitations apply.

- a) The number of target angular positions may be limited by the combination between available angles of the reference artefact and the minimum indexing step of the device under test.
- b) When using reference polygon and the reference indexing table, no random component can be applied to target the angular positioning selection.
- c) Measurements of locking type indexing rotary axes shall be performed after the locking cycle is completed and the (possible) axial movement between the indexing components shall be considered when selecting the measurement system.

9.2.3.1 Periodic angular positioning error motion

Periodic angular positioning error motion of a machine rotary component is measured over two periods of expected periodicity similar to the procedures for the periodic linear positioning error motion measurements. A set of at least 21 evenly spaced target positions is selected over two periods of the expected periodic angular positioning error motion.

One set of unidirectional measurements is made at all the target positions. The periodic angular positioning error, P , is the total range of the measured angular positioning deviations.

10 Alignment of axes of motion — Parallelism, squareness, coaxiality and intersection

10.1 Parallelism of axes of motion

10.1.1 General

It is necessary to measure the parallelism error between axes of linear motion where they are designed to be nominally parallel. For example, parallelism may be checked between the Z- and W-axes on a machining centre, where the Z-axis is an extending spindle and the W-axis is a moving table. It may also be necessary to measure the parallelism error between an axis of linear motion and an axis average line of rotary axis or a spindle or any stationary axis (such as a tail stock axis) or between two axis average lines of rotary axes.

10.1.2 Parallelism error between two axes of linear motion (in two planes)

10.1.2.1 Stationary point run-out method

A linear displacement sensor shall be attached to one of the moving components of the machine so that its stylus rests on a point on the other moving part to measure displacement in the direction perpendicular to its axis of motion. The two moving components shall be moved together in the same direction by the same amount and stationary point run-out as the change in the readings of the linear displacement sensor shall be noted (see Figures 53 and 54) and used to determine the straightness reference line. The orientation of the straightness reference line with respect to the nominal direction of motion (angle of the slope) is the parallelism error.

A second linear displacement sensor can be used in the other plane (perpendicular to the first one) to obtain parallelism in both planes simultaneously.

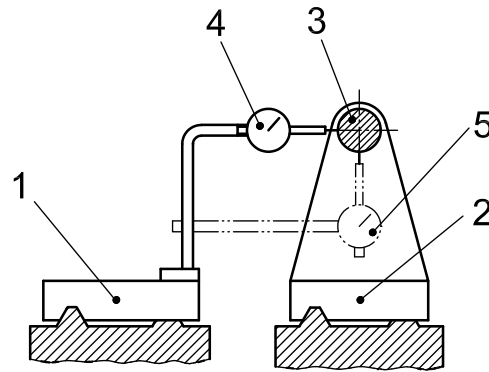

Key

- 1 moving component of 1st axis of linear motion
- 2 moving component of 2nd axis of linear motion
- 3 test mandrel
- 4 linear displacement sensor
- 5 secondary linear displacement sensor

Figure 53 — Parallelism error between two axes of linear motion

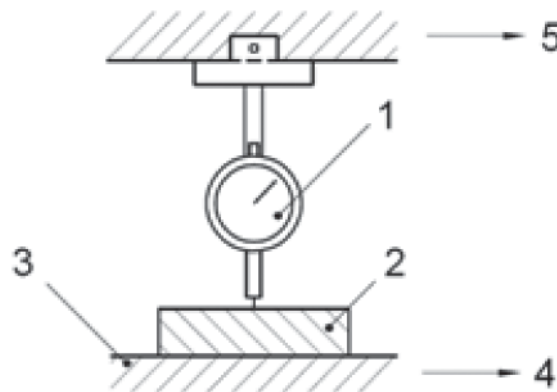

Key

- 1 linear displacement sensor
- 2 slip gauge (optional)
- 3 machine table
- 4 table linear motion direction
- 5 motion direction of 2nd linear axis

Figure 54 — Stationary point run-out measurement

10.1.2.2 Method based on the two straightness error motion measurements

This test is performed by using any straightness measurement device described in 8.2.2. Straightness of each axis of motion shall be measured using the procedure described in 8.2.3.

The parallelism error between two axes of linear motion shall be calculated and reported for two mutually orthogonal planes. For each plane, the straightness deviations of each moving component are measured using a common straightness reference (e.g. artefact or optical beam). The straightness reference lines associated with their respective straightness deviation data should be compared to the common straightness reference line. The calculated slopes of the two straightness reference lines with respect to the common straightness reference are algebraically added to obtain the parallelism error between the two axes of motion.

NOTE The parallelism error is expressed in micrometres per metre ($\mu\text{m}/\text{m}$) or arcseconds ($''$).

10.1.3 Parallelism error between an axis of linear motion and a stationary axis

A test mandrel is mounted on the stationary component to represent the stationary axis. A linear displacement sensor shall be mounted on the moving component and positioned against the test mandrel to read displacement in the direction orthogonal to the direction of motion (see Figure 55). The moving component shall be moved over its travel range of interest. The change in the readings of the linear displacement sensor shall be recorded and used to determine the straightness reference line for the trajectory of the linear motion. The orientation of the straightness reference line with respect to the nominal direction of motion (angle of the slope) is the parallelism error.

NOTE The stationary axis is an axis that does not move during measurement.

Unless all planes are of equal importance, the measurement shall be made, if possible, in two perpendicular planes selected as being the most important for the practical use of the machine.

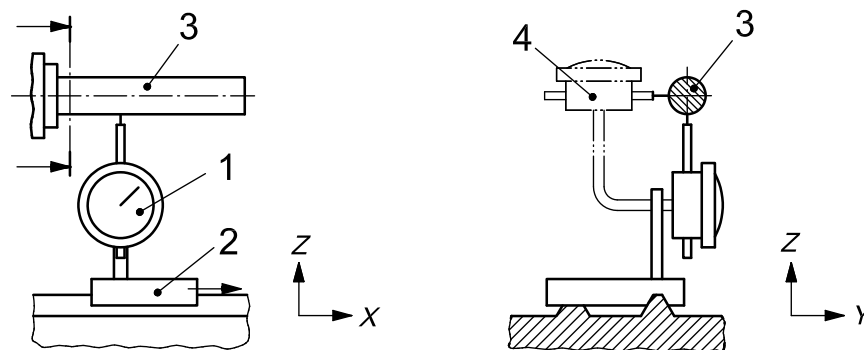

Key

- 1 linear displacement sensor
- 2 axis of linear motion moving component
- 3 test mandrel (stationary axis)
- 4 secondary linear displacement sensor

Figure 55 — Parallelism error between an axis of linear motion and a stationary axis

10.1.4 Parallelism error between an axis of linear motion and an axis average line of a rotary axis or machine spindle

10.1.4.1 General

The relationship between the axis of rotation of a rotary axis or machine spindle and a linear axis is conceptually determined by first establishing an axis average line corresponding to the axis of rotation. Then, the motion of the linear axis is compared against this axis average line. The axis average line of rotation in the plane of measurement (plane containing both the axis of rotation and the linear axis of motion) is determined by averaging straightness measurements at two angular positions of the rotary axis that are 180° apart.

To indirectly represent the axis average line, a reference line perpendicular to the axis of rotation can sometimes be established. Mechanical artefacts or optical methods can be used to generate these axis average lines. The equipment specific test setups given in 10.1.4.2, 10.1.4.3 and 10.1.4.4 are examples only, any other instrument providing comparable measurement uncertainties can be used instead.

10.1.4.2 Method using laser straightness interferometer

The setup for measurement using a laser straightness interferometer is shown in Figure 56.

A straightness reflector shall be mounted to the rotary table or spindle and aligned such that its measurement axis is close to the axis of rotation and the straightness error motion measurement is in one of the orthogonal planes of interest. The straightness error motion measurement shall first be made with the straightness reflector and rotary axis in the original angular position. The straightness error motion measurements shall then be repeated after the reflector and rotary axis are rotated 180°. The parallelism error is one half the algebraic sum of the slopes of the straightness reference lines with respect to the nominal direction of linear motion measured in two angular positions.

By changing the angles of this measurement to 90° and to 270°, the parallelism error in the other orthogonal plane may also be obtained.

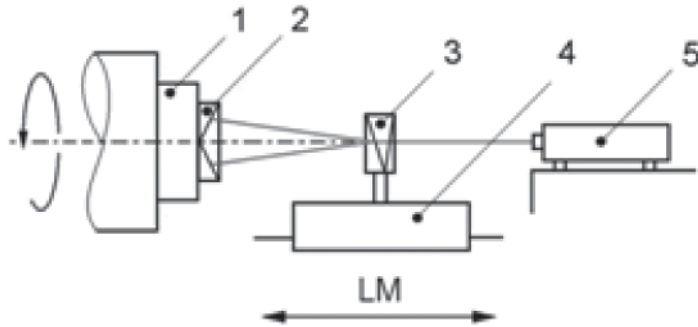

- Key**
- 1 spindle or rotary axis
 - 2 straightness reflector (bi-mirror)
 - 3 Wollaston prism (interferometer)
 - 4 moving component
 - 5 laser head
 - LM linear motion direction

Figure 56 — Parallelism error measurement with straightness interferometer

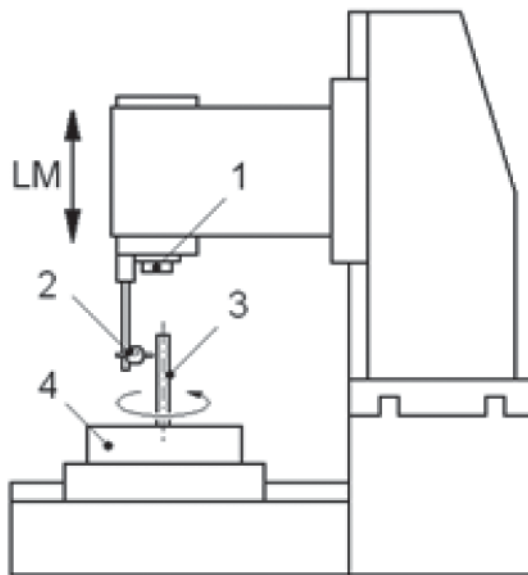

- Key**
- 1 spindle
 - 2 linear displacement sensor
 - 3 test mandrel
 - 4 rotary table
 - LM linear motion direction

Figure 57 — Parallelism error measurement with test mandrel

10.1.4.3 Method using a test mandrel or a straightedge and a linear displacement sensor

A test mandrel shall be mounted and centred on the machine spindle or rotary table. A linear displacement sensor shall be mounted on the linear moving component of the machine to contact the side of the test mandrel. The straightness error motion measurement shall be made by measuring displacement against the mandrel, while traversing the linear moving component along the length of the mandrel as shown in Figure 57. The straightness error motion measurement shall be repeated after the machine spindle/rotary table is rotated 180°. The parallelism error is one half the algebraic sum of the slopes of the straightness reference lines with respect to the nominal direction of linear motion measured in two angular positions.

NOTE 1 Rotating the spindle/rotary table 180° ensures that any misalignment of test mandrel to machine spindle/rotary table is eliminated.

NOTE 2 This method, coupled with straightedge reversal, yields both straightness error and parallelism error.

By performing these measurements again with the linear displacement sensor reading against the test mandrel at 90° with respect to the first set of measurements, the spindle parallelism error in the orthogonal direction can be determined.

10.1.4.4 Method using a test sphere and a linear displacement sensor

The test sphere shall be mounted on the linear moving component of the machine and the linear displacement sensor shall be mounted on the rotary axis under test (rotary table or spindle) as shown in Figure 58. The test sphere shall be centred with respect to the axis of rotation average line by moving two machine axes orthogonal to the axis under test, while rotating the rotary axis or spindle. The test sphere shall then be moved to another location along the axis of linear motion under test (h in Figure 58) by moving the machine slide. The displacement sensor is re-positioned to read against the test sphere at this new location. The error in the centre position shall be recorded as half the difference of the readings of the displacement sensor at opposing points on the sphere.

The parallelism error between the rotary axis and the linear axis shall be computed by dividing the error in centre position between the two positions by the distance between the two positions (h in Figure 58).

More intermediary positions along the axis of linear motion may be chosen to improve the results (e.g. by using least squares calculations).

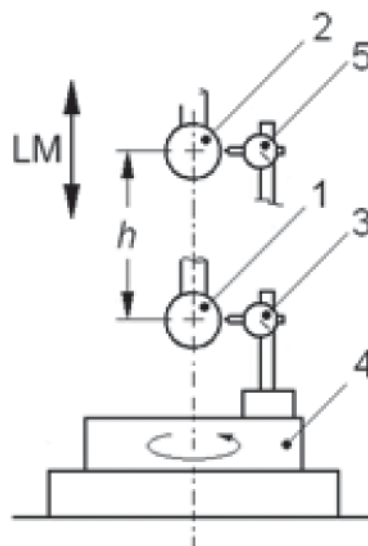

Key

- | | | | |
|---|--|-----|--|
| 1 | tests sphere at position 1 | 5 | linear displacement sensor at position 1 |
| 2 | test sphere at position 2 | h | distance between position 1 and position 2 |
| 3 | linear displacement sensor at position 2 | LM | linear motion direction |
| 4 | rotary axis under test (rotary table or spindle) | | |

Figure 58 — Measurement of parallelism error between a linear axis and a rotary axis using a test sphere

10.1.5 Parallelism error between two axes of rotation

10.1.5.1 General

The relationship between two axes of rotation is conceptually determined by first establishing an axis average line corresponding to one of the axis of rotation. Then, the other axis of rotation is compared against this axis average line. The axis average line of rotation in the plane of measurement (machine Cartesian coordinate plane nominally parallel to both axes of rotation) is determined by averaging the measurements at two angular positions of the first rotary axis that are 180° apart.

To indirectly represent the axis average line, a reference line perpendicular to the axis of rotation can sometimes be established. Mechanical artefacts or optical methods can be used to generate these axis average lines. The equipment specific test setups for measuring parallelism error between two coaxial axes of rotation given in 10.1.5.2 and 10.1.5.3 are examples only, any other instruments providing comparable measurement uncertainties can be used instead.

10.1.5.2 Method using a test mandrel

A test mandrel shall be mounted on one of the spindles (or rotary table). The test mandrel shall be aligned with respect to the axis of rotation of the spindle by minimizing the run-out in two orthogonal radial directions. A fixture holding two linear displacement sensors, separated by a distance, d (see Figure 59), shall be mounted on the other spindle of the machine. The displacement sensors are adjusted to contact the circumference of the test mandrel at two locations along its length. The displacement sensors shall be rotated around the test mandrel using the second spindle recording the linear displacements against the mandrel as a function of the angular position of the second spindle. A reference circle centre (C_X , C_Y) for each set of data from the two sensors, is calculated by fitting each data set to a least squares circle. The difference in reference circle centre coordinates in one direction, ($C_{X2} - C_{X1}$), divided by the distance, d , between the sensors, results in the angle between the two axes of rotation, which is the parallelism error. Similarly, reference circle centre coordinates in the other direction (C_{Y1} and C_{Y2}) provide the parallelism error in the plane orthogonal to the first one (see Figure 59).

It is necessary, particularly in the case of horizontal axes, to have very rigid mountings with negligible deflection.

To completely eliminate the effects of misalignment between the test mandrel and the first spindle, the above-mentioned measurement may be repeated after the first spindle is rotated 180°. In such a case, the parallelism deviation is one half the algebraic sum of the two angles calculated.

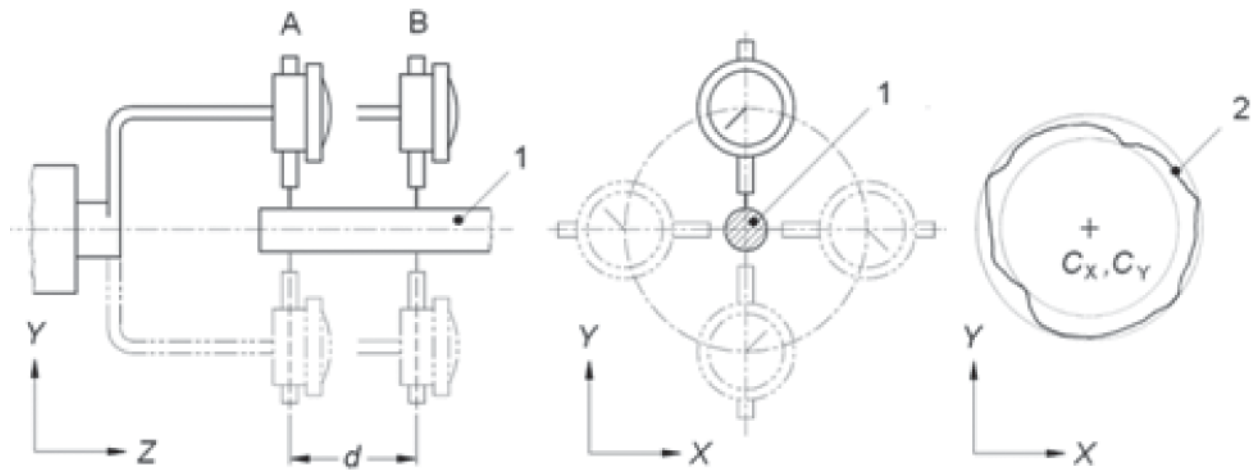

Key

- 1 tests mandrel
- 2 trajectory of linear displacement sensors against the test mandrel
- A, B linear displacement sensors
- C_X X-axis coordinate of reference circle centre
- C_Y Y-axis coordinate of reference circle centre
- d distance between linear displacement sensors A and B

Figure 59 — Parallelism error between two axes of rotation using a test mandrel

10.1.5.3 Method using two test spheres

Two test spheres, axially separated by some length, are mounted on one of the spindles or rotary tables. Each sphere is individually centred to have a minimum run-out with respect to the axis of rotation average line. The fixture holding two linear displacement sensors separated by a distance shall be mounted on the other spindle or rotary table. The test procedure is the same as the one described in 10.1.5.2.

10.2 Coaxiality error of axis average lines

10.2.1 General

Four parameters are generally required to specify the coaxiality error between the two axis average lines (see 3.7.2). Two of these parameters specify parallelism error between the two axes and the other two are the offsets between the two axes, all specified in two orthogonal planes (e.g. vertical and horizontal). Therefore, the methods used to measure parallelism error between two axes of rotation (see 10.1.5) may also be used to measure coaxiality error. Similarly, any method used for measuring coaxiality error, may also be used to measure parallelism error between two axes of rotation.

10.2.2 Stationary point run-out method (rim and face method)

This method is a very practical measurement method to yield both offset and parallelism error, while not requiring any precision artefacts. This measurement method requires the use of two linear displacement sensors mounted on one of the spindles (or rotary table) and a target bracket mounted on the other spindle (or rotary table) as shown in Figure 60. Displacement sensors are set to measure displacement of the target bracket in the radial (rim) and the axial (face) directions.

The two axes are rotated together reading the displacement sensors at the 0°, 90°, 180° and 270° positions. These measurements should be repeated three times to avoid thermal effects. The coaxiality error parameters of the two axes in two planes are given by Equations (11) to (14):

Vertical offset, V_O :

$$V_O = \frac{(R_0 - R_{180})}{2} \quad (11)$$

Vertical angle, V_A :

$$V_A = \frac{(F_{180} - F_0)}{D} \quad (12)$$

Horizontal offset, H_O :

$$H_O = \frac{(R_{90} - R_{270})}{2} \quad (13)$$

Horizontal angle, H_A :

$$H_A = \frac{(F_{270} - F_{90})}{D} \quad (14)$$

where

- R_0 is the mean radial reading at 0° angular position;
- R_{90} is the mean radial reading at 90° angular position;
- R_{180} is the mean radial reading at 180° angular position;
- R_{270} is the mean radial reading at 270° angular position;
- F_0 is the mean axial reading at 0° angular position;
- F_{90} is the mean axial reading at 90° angular position;
- F_{180} is the mean axial reading at 180° angular position;
- F_{270} is the mean axial reading at 270° angular position;
- D is the diameter of the circle travelled by the face displacement sensor centreline.

NOTE The circle diameter defined by the linear displacement sensor measurement point for the face measurement corresponds to the length over which the coaxiality error is assessed.

Before commencing the test, the sag (compliance) of the brackets may be measured. This is done by attaching the brackets to a stiff mandrel supported between centres as shown in Figure 61. For spans of up to 200 mm, a steel mandrel 50 mm in diameter is considered adequate. (For very high accuracy machines, a calculation of the required mandrel diameter should be made or a correction applied for mandrel sag.) The displacement sensors are zeroed at the top position (0° position in Figure 61) and the mandrel rotated until the linear displacement sensors are at the bottom position (180° position in Figure 61). The readings of both displacement sensors indicate the effect of the sag in each direction.

When only one of the two axes is an axis of rotation, the arm carrying the measuring instrument should be fixed to the mandrel representing the axis around which rotation is effected. If the measuring instrument is required to rotate around a fixed mandrel, it should be mounted on a ring rotating with a minimum amount of

play. This ring should be of sufficient length to ensure that the reading is not affected by the clearance in the ring.

The parallelism error measured by the rim and face method is affected by axial error motion of the rotating components being tested. To eliminate this source of measurement uncertainty, the measurement setup may be modified as shown in Figure 62. In this setup, a second radial displacement sensor mounted on the target spindle replaces the axial displacement sensor. Then, the horizontal and vertical angle calculations are based on the differences of the offsets measured by the sensors divided by the distance between the two sensors.

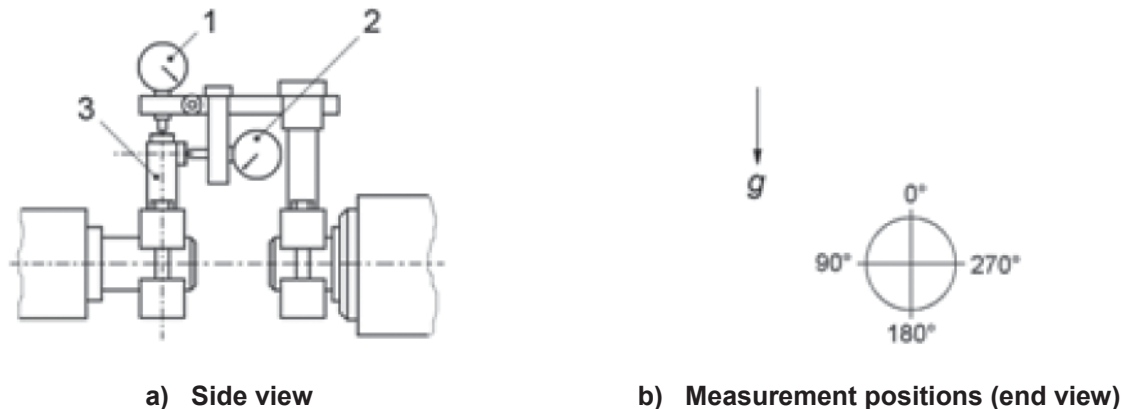

Key

- 1 radial linear displacement sensor
- 2 axial linear displacement sensor
- 3 target bracket
- g* gravity

Figure 60 — Coaxiality error measurements using stationary point run-out method

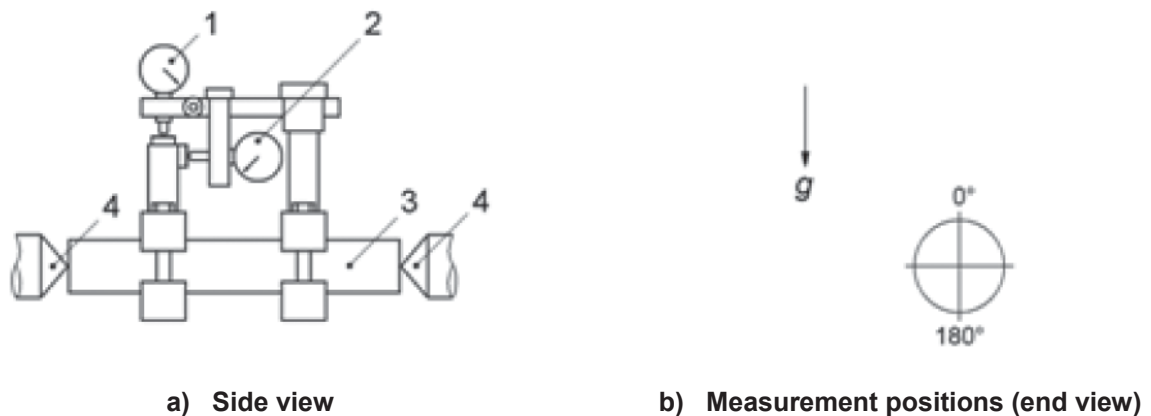

Key

- 1 radial linear displacement sensor
- 2 axial linear displacement sensor
- 3 steel mandrel
- 4 centre
- g* gravity

Figure 61 — Calibration of the sag of the test rig

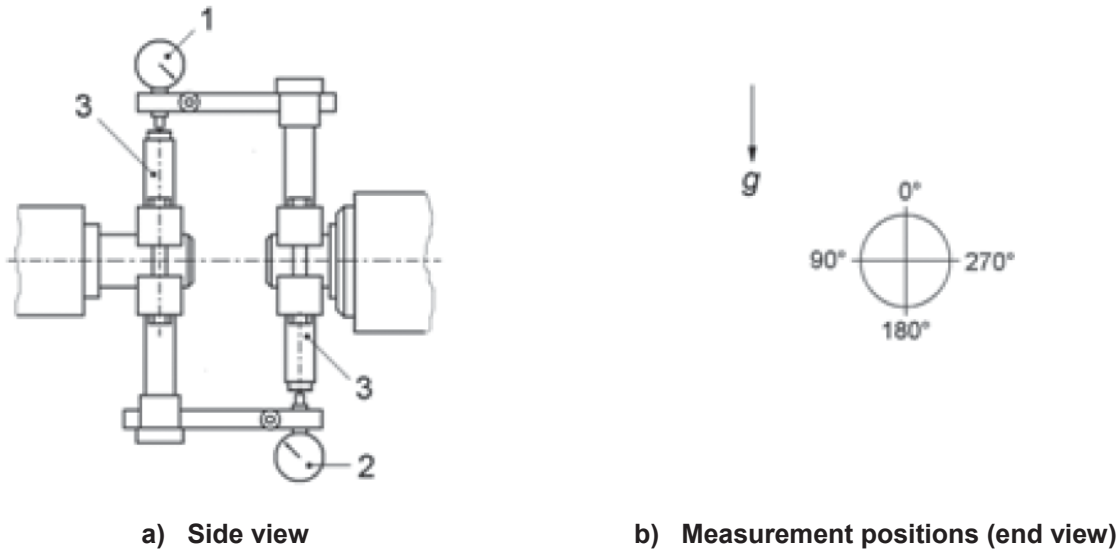

- Key**
- 1 radial linear displacement sensor
 - 2 second radial linear displacement sensor
 - 3 target bracket
 - g* gravity

Figure 62 — Elimination of influence of axial error motion in coaxiality error measurements

10.3 Squareness error of axes of motion

10.3.1 General

The measurement of squareness error between two axes of motion consists of two measurements of parallelism error between an axis of linear motion and a stationary axis, where the stationary axes are represented by a reference square or an indexable straightedge. Measurement methods described in Clause 11 are also used for evaluation of squareness error between axes of motion.

10.3.2 Squareness error between two axes of linear motion

10.3.2.1 General

Squareness error can be measured with a variety of setups and instruments as described in 10.3.2.2 to 10.3.2.5. The procedure is similar in all these cases. Two square measurement reference lines are established in the middle of the work zone where possible. The measurement reference lines are aligned such that they are nominally parallel to the axes of motion, whose squareness error with respect to each other is to be measured. For each axis in turn, the linear moving component of the machine is traversed along its motion axis. A linear displacement sensor measures the lateral displacement (in the direction orthogonal to the axis of motion) (straightness deviation) between the functional point of the component and the measurement reference line corresponding to this axis. The parallelism error of each axis of motion to the corresponding measurement reference line is determined as described in 10.1.3. The algebraic sum of the two parallelism errors results in the squareness error between the two axes of linear motion.

10.3.2.2 Method using mechanical reference square and a linear displacement sensor

The reference square shall be placed in such a way that its reference surfaces are nominally aligned with the two axes of motion whose squareness to each other is to be measured. A linear displacement sensor shall be used to measure parallelism error of each axis of motion to its corresponding reference surface of the square (stationary axis). An example of the measurement setup is shown in Figure 63.

One arm of the reference square may be lined up exactly to the first trajectory by means of a linear displacement sensor and the second trajectory is measured in accordance with 10.1.3. The arm of the square may also be set parallel to the first trajectory with a greater inclination than the tolerance, so as to allow the displacement sensors to work in one direction only, eliminating their drag.

When a reference square is used for measurement, the reversal measurement procedure (rotate the reference square 180° to cancel the artefact error) is recommended. The linear displacement sensor is re-bracketed after the reversal to ensure that both measurements address the same axis motions and surfaces of the reference square. If this is not done, the result is affected by an angular error motion of one of the axes. In such cases, the calculated squareness error represents an average of the squareness errors at two axis positions (see Figure 64). A two-dimensional (2-D) ball plate is also applicable to the same measurement.

NOTE The deflection of the components caused by the loads supported may need to be taken into consideration.

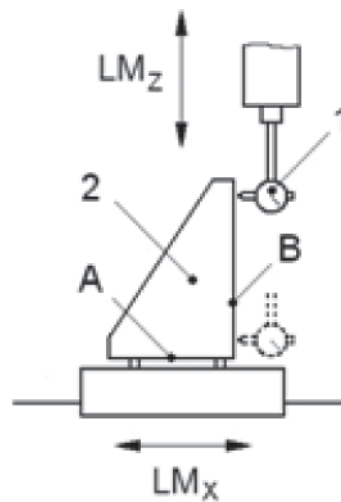

Key

- 1 linear displacement sensor
- 2 reference square
- A 1st reference surface of reference square
- B 2nd reference surface of reference square
- LM_x linear motion along X-axis (example)
- LM_z linear motion along Z-axis (example)

Figure 63 — Squareness error measurement using reference square

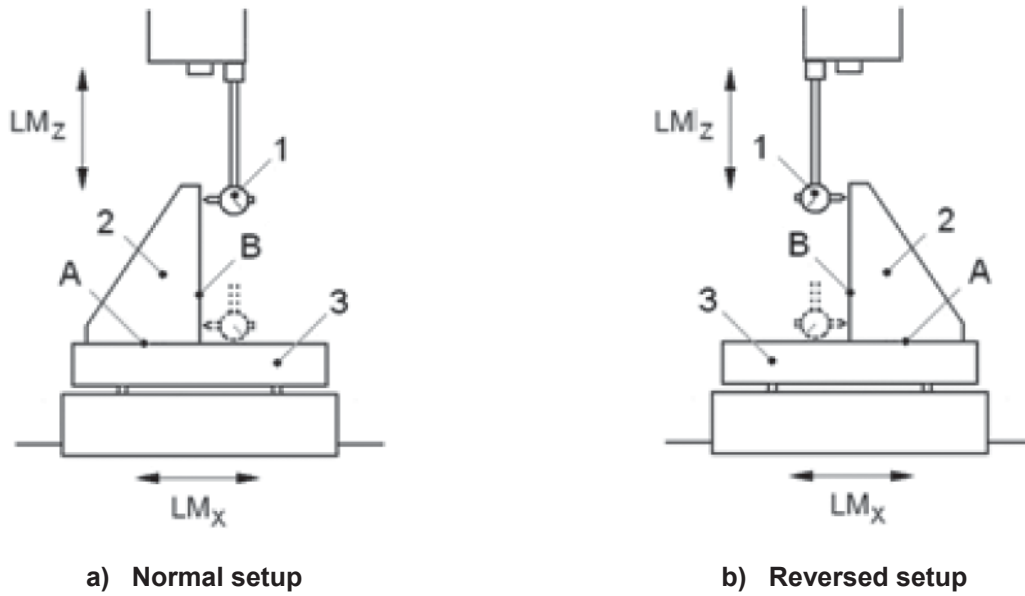

- Key**
- 1 linear displacement sensor
 - 2 reference square
 - 3 straightedge
 - A 1st reference surface of reference square
 - B 2nd reference surface of reference square
 - LM_x linear motion along X-axis (example)
 - LM_z linear motion along Z-axis (example)

Figure 64 — Reversal method on the squareness measurement

10.3.2.3 Method using reference straightedge and a reference indexing table

The reference straightedge shall be mounted on a reference indexing table, which shall be rigidly attached to the table of the machine. The reference straightedge shall be aligned initially along one machine axis and the parallelism error between the axis of motion and this reference surface (stationary axis) shall be measured as described in 10.1.3. The reference indexing table shall then be rotated 90° and the parallelism error measurement shall be repeated for the second axis (see Figure 65).

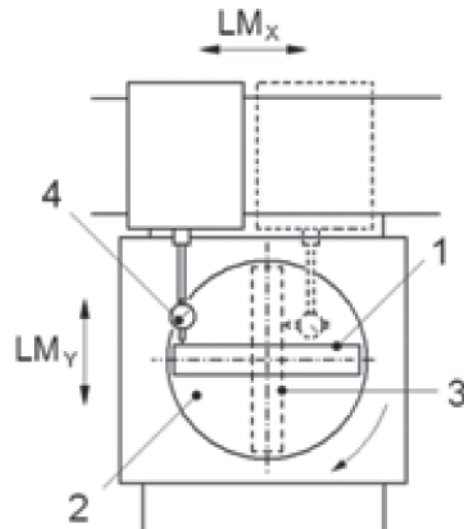

Key

- 1 straightedge in initial position
- 2 reference indexing table
- 3 straightedge position after 90° rotation
- 4 linear displacement sensor
- LM_x linear motion along X-axis (example)
- LM_y linear motion along Y-axis (example)

Figure 65 — Squareness error measurement with reference indexing table

10.3.2.4 Method using optical square and laser straightness interferometer

The measurements may be performed in two ways. In the first method, the straightness error of the first trajectory is measured by aligning the laser beam to the straightness reflector (bi-mirror) through the optical square. Next the Wollaston prism is moved to the second moving component of the machine and the straightness error of the second trajectory is measured without moving the optical square, straightness reflector (bi-mirror), or laser beam [see Figure 66 a) and b)].

In the second method, the straightness error of the first trajectory is measured, as previously. The optical square is then removed and the laser beam realigned with the straightness reflector (bi-mirror) by moving the laser beam only. The straightness reflector (bi-mirror) shall not be moved during the procedure and shall be supported on a stable, stationary stand.

For some machine tool configuration, the use of an additional large retroreflector and turning mirror may be required [see Figure 66 c)]. Reference to the instrument manufacturer's instructions is strongly recommended.

An EVE test is recommended before the measurements.

10.3.2.5 Data analysis

The measurements obtained are first plotted as shown in Figure 67. Reference straight lines for the trajectories can be determined as described in 8.2.3. For this purpose, the least squares fit method is recommended. The slopes of the lines are calculated. These slopes correspond to the angular errors between each axis of motion and its associated measurement reference line.

Depending on the sign convention chosen for the measurement, these two angles should be either subtracted or added to determine the initial squareness error. For the purposes of this part of ISO 230, positive squareness error indicates greater than 90° and the negative squareness error indicates less than 90°.

Next, the correction for the squareness error of the reference square/reference indexing table should be applied (see Clause 5).

The locations of measurement reference lines within the work zone shall be reported along with the calculated squareness error value.

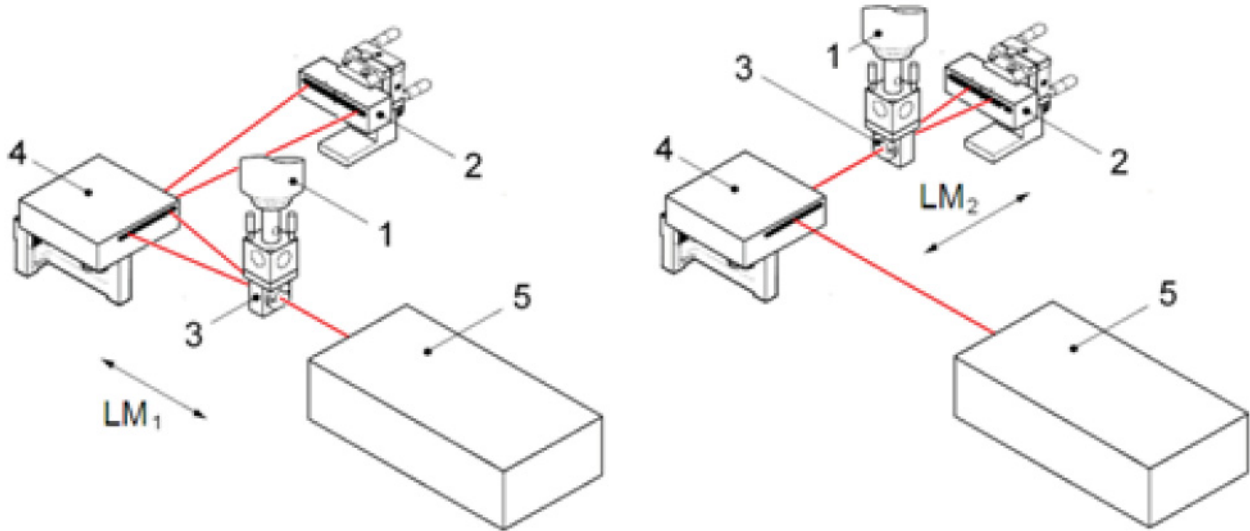

a) Example 1 — Measurement of 1st linear axis for measurement in the horizontal plane

b) Example 1 — Measurement of 2nd linear axis for measurement in the horizontal plane

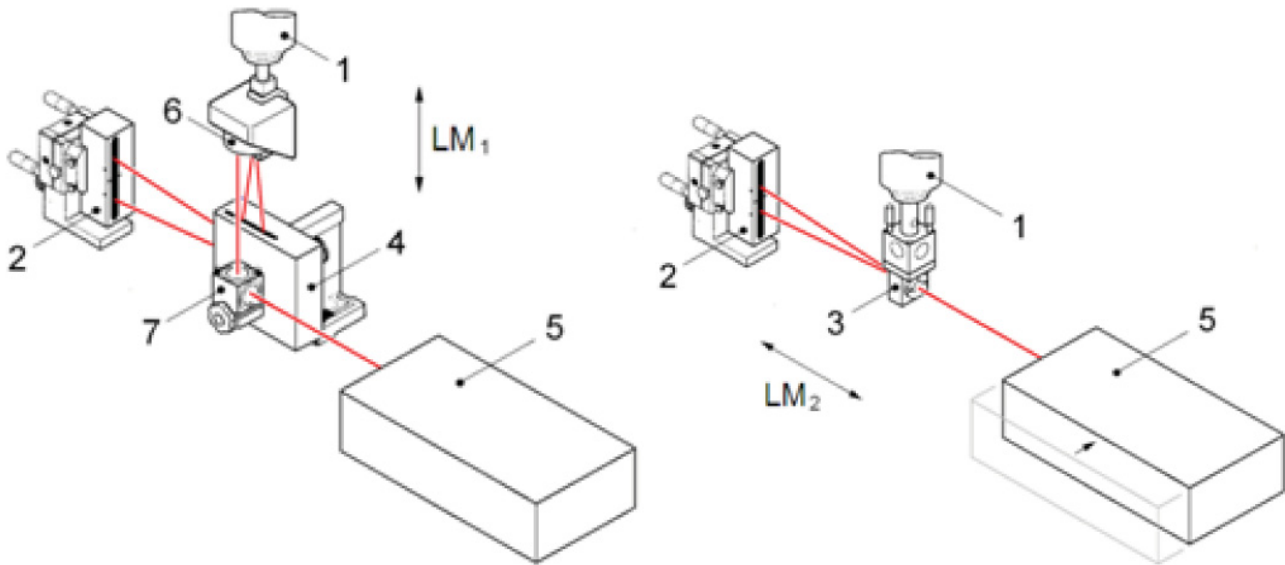

c) Example 2 — Measurement of 1st linear axis for measurement in the vertical plane

d) Example 2 — Measurement of 2nd linear axis for measurement in the vertical plane

Key

- | | | | |
|---|------------------------------------|-----------------|---|
| 1 | machine spindle | 6 | assembly with large retroreflector and Wollaston prism (interferometer) |
| 2 | straightness reflector (bi-mirror) | 7 | turning mirror |
| 3 | Wollaston prism (interferometer) | LM ₁ | 1st linear axis motion |
| 4 | optical square | LM ₂ | 2nd linear axis motion |
| 5 | laser head | | |

Figure 66 — Squareness error measurements using optical square and laser interferometer

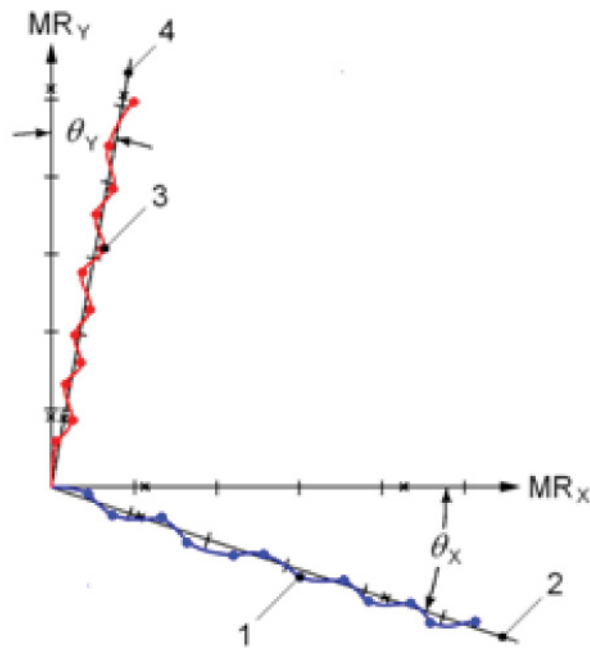

Key

- MR_X X-axis measurement reference line
- MR_Y Y-axis measurement reference line
- 1 measured X-axis motion trajectory
- 2 X-axis trajectory reference straight line
- 3 measured Y-axis motion trajectory
- 4 Y-axis trajectory reference straight line
- θ_X X-axis trajectory slope
- θ_Y Y-axis trajectory slope

Figure 67 — Data analysis for squareness error measurements

10.3.2.6 Estimating of squareness error by means of circular test and diagonal displacement test (indirect method)

Squareness error between two axes of linear motion can be estimated using circular tests (see ISO 230-4) and diagonal displacement tests (see ISO 230-6).

For the circular test, the difference of the two diameters at $\pm 45^\circ$, ΔL , divided by the nominal diameter is the squareness error as a ratio.

To enlarge the geometric influence on squareness error, circular trajectory should be as large as possible (see Annex B of ISO 230-4:2005). The results obtained by small diameter trajectory indicate only the local squareness error.

To eliminate possible backlash and servo related effects in determining squareness error, the use of a 360° bi-directional test at low feedrate with least squares-fit software is recommended.

For diagonal displacement test, the length difference of the two face diagonals at 45° , ΔL , divided by the nominal diagonal, D , gives the squareness error as a ratio.

If the two axes are not of the same length, the diagonals can also be used. Squareness error, S , as a ratio is calculated by the following simplified equation, Equation (15):

$$S = D_0 \cdot (D_1 - D_2) / (2 X Y) \quad (15)$$

where

D_0 is the nominal diagonal length;

D_1 and D_2 are measured diagonal lengths;

X and Y are programmed travel lengths along each axis of linear motion.

NOTE Measurement uncertainty increases with increased aspect ratio.

10.3.3 Squareness error between an axis of linear motion and an axis average line of a rotary axis or a machine spindle

The relationship between the axis of rotation of a rotary axis or machine spindle and a linear axis is conceptually determined by first establishing an axis average line corresponding to the axis of rotation. Then, the motion of the linear axis is compared against this axis average line. The axis average line of rotation in the plane of measurement (machine Cartesian coordinate plane nominally parallel to the axis of rotation and the axis of linear motion) is determined by averaging straightness error measurements at two angular positions of the rotary axis that are 180° apart. To indirectly represent the axis average line of rotation, sometimes a measurement reference line perpendicular to the axis of rotation can be established. Mechanical artefacts or optical methods can be used to represent these measurement reference lines. A typical setup for such a measurement is shown in Figure 68.

The straightedge is mounted so as to straddle the rotary axis centre and the straightness deviation of the axis of linear motion is measured either optically or mechanically. The slope of the straightness reference line is the angle between the axis of linear motion and the straightedge surface. Next, the rotary axis is rotated 180° and a similar measurement performed. Figure 68 shows an arbitrary “forward direction” with the rotary axis at zero angle and the “reverse direction” with the rotary axis rotated 180°.

The angle, β , in Figure 68 is the squareness error between the straightedge and the rotary axis resulting from supporting fixtures, while the angle, E_{B0C} , is the squareness error. The measured angles and the respective orientations (forward and reverse) are denoted by: φ_F and φ_R . The squareness error, E_{B0C} , is calculated using Equation (16):

$$E_{B0C} = \frac{1}{2}(\varphi_F + \varphi_R) \quad (16)$$

By performing these measurements again, beginning with the first measurement at 90° with respect to the first measurement in the initial step, squareness error between the axis of rotation and the other orthogonal axis of linear motion can also be determined.

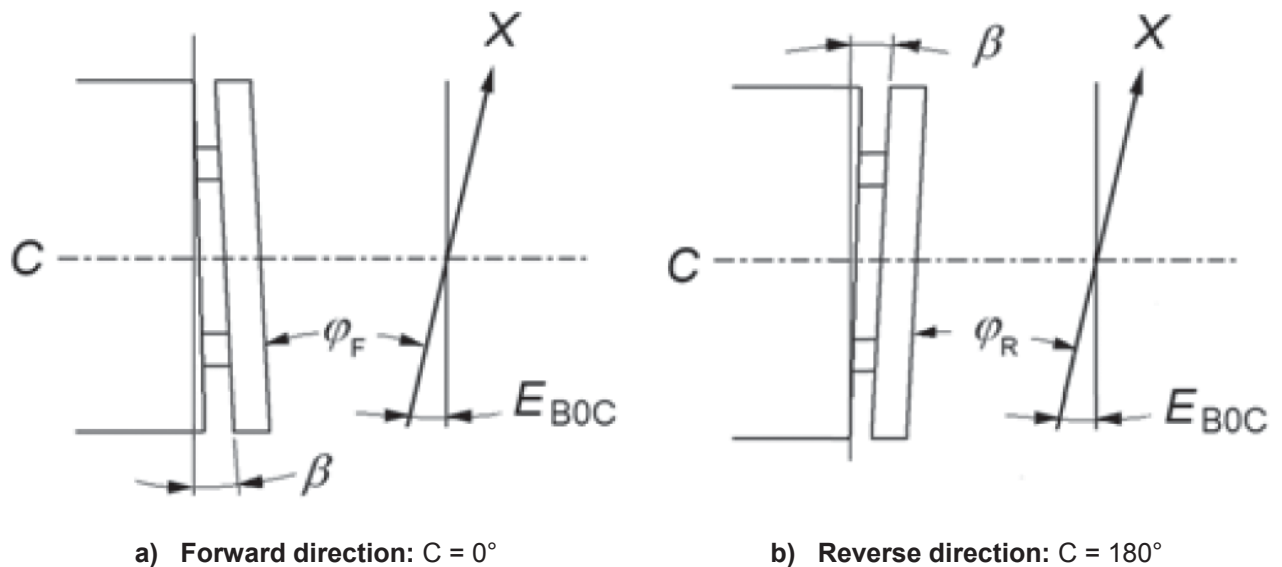

Figure 68 — Squareness error between a linear axis and a rotary axis

10.3.4 Squareness error between two axis average lines

A test mandrel is mounted and aligned with respect to the axis average line of the first rotary axis. Then, a linear displacement sensor is attached to the second rotary axis through an arm radially offset with respect to the second axis average line. The linear displacement sensor is brought into contact with the test mandrel and the first rotary axis is rotated through several full turns while the data from the linear displacement sensor is recorded. Then, the second rotary axis holding the linear displacement sensor is rotated 180° and the first rotary axis is rotated again through several full turns while the data from the linear displacement sensor are recorded (see Figure 69). The centres of least squares circles are calculated corresponding to the two sets of data. The difference between the centre coordinates along the second axis of rotation divided by the sensor distance between the two sets of data results in the squareness error between the two axis average lines.

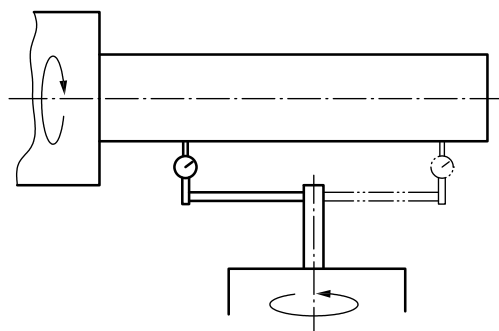

Figure 69 — Squareness error between two axis average lines

10.4 Intersection of axis average lines

10.4.1 General

For most machine tools, multiple axes of rotations are either parallel or orthogonal to each other. When they are non-parallel, it is necessary to test the point of intersection either directly or indirectly. Direct measurements use precision artefacts representing at least one of the axes.

10.4.2 Intersection of square axis average lines

A test sphere is attached to one of the rotary axes and adjusted/aligned such that it represents the axis average line of the rotary axis at the nominal location of the axis average line of the second rotary axis. A linear displacement sensor is attached to the second rotary axis to measure against the test sphere (see Figure 70). The centre of the best-fit circle (in the direction orthogonal to both axis average lines) obtained from the linear displacement sensor readings indicate the distance between the two axes of rotation.

The following alternative procedure, called “Chase the spot test”, may also be used;

- a) set the indicator against the artefact, then rotate the first axis by 180°;
- b) then, rotate the second axis by 180°;
- c) the indicator should read the same value for intersecting axis average lines.

10.4.3 Intersection of non-square axis average lines

The point of intersection of two non-parallel (and non-orthogonal) axes can be determined by means of measurements made between the test mandrels representing these axes. The method is the same as that for checking the equidistance of two axes with an additional plane (see 12.3.3.2). This check is easier if the test mandrels are replaced by two suitably machined bars, with flat face in a plane parallel to their axes. Measurements are taken between the two flat faces to determine the error of intersection (see Figure 71). The case represented in Figure 71 corresponds to swivelling grinding head for cone grinding.

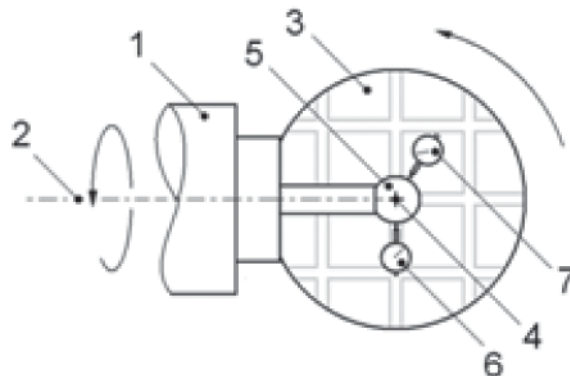

Key

- 1 spindle
- 2 spindle axis average line
- 3 rotary table
- 4 rotary table axis average line
- 5 test sphere
- 6 linear displacement sensor at start position
- 7 linear displacement sensor at intermediate position

Figure 70 — Intersection of orthogonal axis average lines

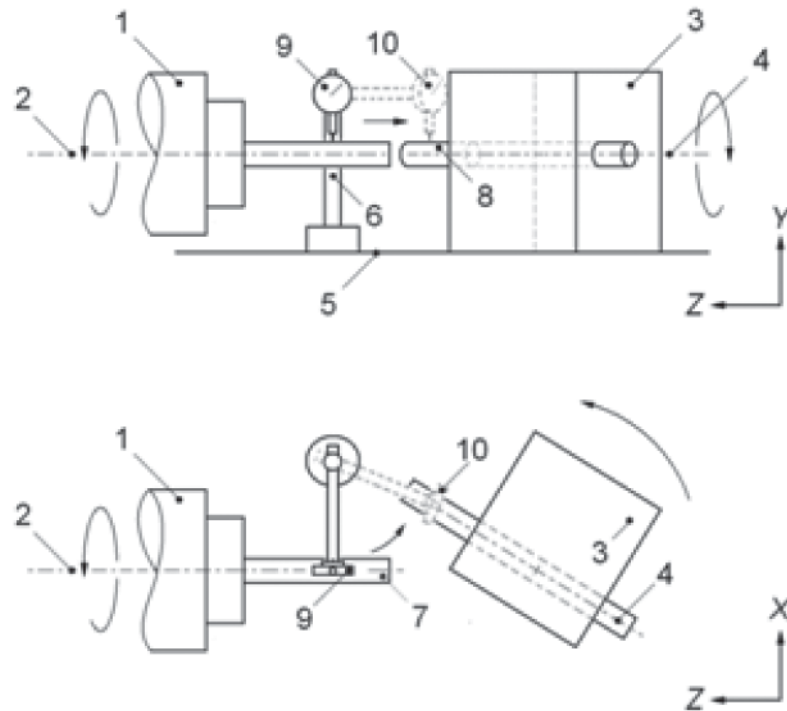

Key

- 1 spindle 1
- 2 spindle 1 axis average line
- 3 swivelling head
- 4 swivelling head spindle axis average line
- 5 reference surface
- 6 linear displacement sensor support
- 7 test mandrel 1
- 8 test mandrel 2
- 9 linear displacement sensor in measuring position 1
- 10 linear displacement sensor in measuring position 2

Figure 71 — Intersection of non-orthogonal axis average line

10.4.4 Indirect measurement

Indirect measurement may be made by using a separate reference plane, for example a surface plate which is set up parallel to the two axes. Measurements are taken from the reference plane to each axis and compared.

11 Multi-axes motion (kinematic) tests

11.1 General

The tests described in this clause provide a quick and efficient way of assessing and estimating a numerically controlled machine tool's contouring accuracy as well as its positioning capability over its work volume. Such capabilities are affected by various sources of geometric errors (straightness error, squareness error, etc.) associated with multiple axes of motion. Kinematic tests provide a way of observing the combination of those error sources. Since they are relatively easy to carry out, highlighting multiple sources of error and multiple axes with one measurement, such tests are also used for periodic checking of machine performance and verifying performance after unexpected events, such as crashes.

11.2 Linear trajectories

11.2.1 General

The (simultaneously coordinated) two or more linear axes are moved nominally on a straight line, on a face or a body diagonal of the prismatic work volume. During such movement, the positioning or straightness error motions are measured, and deviations are recorded and evaluated.

11.2.2 Diagonal displacement tests

11.2.2.1 General

The purpose of diagonal displacement tests is the quick estimation of the volumetric performance of a numerically controlled machine tool. Complete testing of the volumetric performance of a machine tool is a difficult and time-consuming process. Diagonal displacement tests reduce the time and cost associated with testing the volumetric performance.

Diagonal displacement tests, i.e. positioning tests on face or body diagonals of the prismatic work volume, are multi-axes kinematic tests. For setup and evaluation, see ISO 230-6. Indication for reduced volume shall be by stating "reduced volume" after the parameter stated (see ISO 230-6).

11.2.2.2 Face diagonal test

The test procedure is conceptually similar to that of the individual linear axes (described in ISO 230-2), except that linear displacements are not measured parallel to a linear axis, but along the diagonals of the machine tool coordinate planes.

11.2.2.3 Body diagonal test

The test procedure is conceptually similar to that of the individual linear axes (described in ISO 230-2), except that linear displacements are not measured parallel to a linear axis, but along the diagonals of the prismatic work volume of the machine tool.

11.2.3 Diagonal straightness tests

11.2.3.1 General

The purpose of the diagonal straightness tests is to assess the simultaneous coordination of moving two or more linear axes of a machine tool.

In principle, test methods described in 8.2 also apply to diagonal straightness tests.

11.2.3.2 Face diagonal straightness test

The two linear axes are programmed to move the functional point along a straight line trajectory defined by the diagonal of the rectangular surface generated by two linear motions. The straightness error is measured and assessed as described in 8.2.

11.2.3.3 Body diagonal straightness test

The three linear axes are programmed to move the functional point along a straight line trajectory defined by the diagonal of the prismatic work volume formed by the three moving orthogonal linear axes. The straightness error is measured and assessed as described in 8.2.

11.3 Circular trajectories

11.3.1 General

The purpose of these tests is to provide a method for the estimation of the contouring performance of a numerically controlled machine tool. Errors in circular contours, which are presented in a circular diagram (as shown in Figure 72), are affected by the geometric errors and dynamic behaviour of the machine at the applied feedrate. The results are a good representation of the results that would be obtained on machined parts in ideal machining conditions, if the diameter and the feedrate are the same for machining and the circular contouring tests. Definitions and test parameters are provided in ISO 230-4 (a typical measurement result is shown in Figure 72).

NOTE 1 ISO 230-4 defines G as “circular deviation”. In this part of ISO 230, a clear distinction is established between the terms “deviation” and “error” (see Clause 3). Therefore, the “circular deviation” indicated in Figure 72 directly corresponds to “circular error” according to Clause 3.

NOTE 2 In actual machining of parts, the tool deflection, tool diameter and workpiece material mechanical characteristics, as well as machining of internal and external surfaces, affect the contouring errors, whereas in circular tests, these error sources are absent.

11.3.2 Full circular trajectories

Since the evaluation of data from circular tests requires least squares fitting to compensate for any setup centring errors, to minimize the computational errors and associated bias, generating full circular paths is strongly recommended.

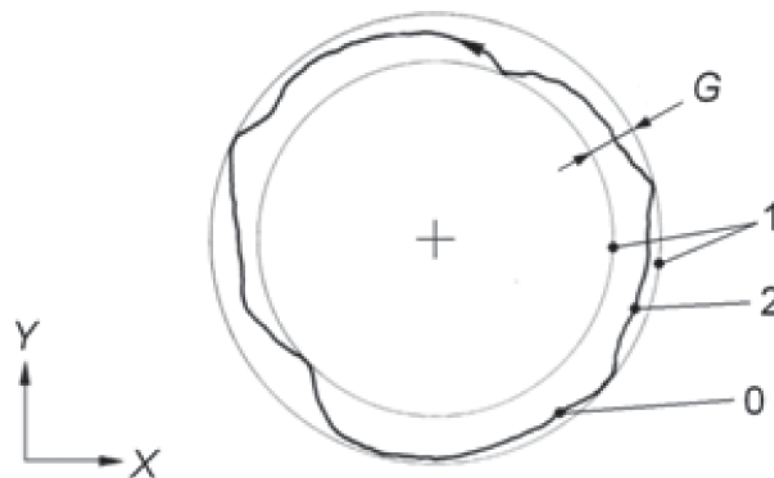

Key

- 0 starting point
- 1 reference circles
- 2 actual path
- G circular deviation, G_{XY}
- + centre of least squares circle fitting the actual path

Figure 72 — Evaluation of circular error G_{XY}

11.3.3 Partial circular trajectories

Where the travel range of an axis involved in the circular tests or the instruments and fixtures used for tests prevent the motion of the functional point from completing the full circular path, assessment may be carried out on partial circular trajectories. However, it should be noted that the data processing can be influenced by computational errors and therefore, it is strongly recommended that centring of the instrument with respect to the programmed motions be physically done with extreme caution. For partial circular trajectories, evaluating radial deviation, F , instead of circular deviation, G , is recommended (see Note 1 of 11.3.1).

11.3.4 Measuring instruments, methods and setups for circular trajectories generated by two or three linear axes — Two-dimensional or three-dimensional circular tests

11.3.4.1 General

Two linear axes are programmed such that the functional point follows a full or partial circular trajectory in a plane defined by the two moving linear axes (XY, YZ or ZX).

Circular tests, especially if carried out with a telescoping ball bar or 2-D digital scale, are not limited to measurements in the principal planes XY, YZ and ZX of the machine tool. Circular tests can also be carried out in any orientation in space, provided the NC allows the interpolation of X-, Y- and Z-axis for a circular trajectory in any orientation.

11.3.4.2 Method using rotating one-dimensional linear displacement sensor

A 1-D linear displacement sensor is programmed to move on a circular trajectory. The sensor is rotated by a special rotary fixture and measures displacement relative to a test mandrel (see Figures 73 and 74) or a target fixed on a special rotary fixture and rotated in conjunction with the sensor. The signal of the sensor is plotted on a circular diagram (see Figure 72). The circular diagram can be produced, e.g. by a synchronized polar plotter, by computer evaluation or by use of an additional rotary encoder in the rotary fixture and a polar plotter.

11.3.4.3 Method using circular master and two-dimensional displacement sensor

A 2-D probe is programmed to move on a circular trajectory (see Figure 75). The programmed centre and the diameter of the circular trajectory are chosen so that the 2-D probe keeps in contact with the circular reference artefact at all times. The probe readings in two directions (X and Y) are recorded. These values are plotted on a circular diagram (see Figure 72).

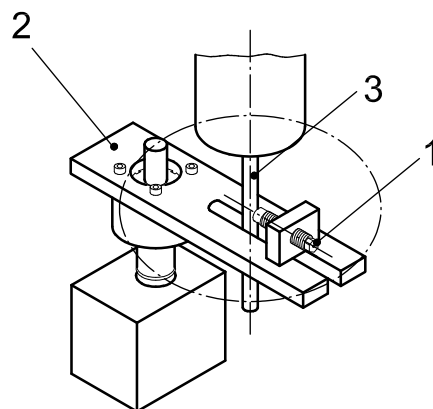

Key

- 1 one-dimensional linear displacement sensor
- 2 special rotary fixture
- 3 test mandrel

Figure 73 — Circular test using one-dimensional displacement sensor

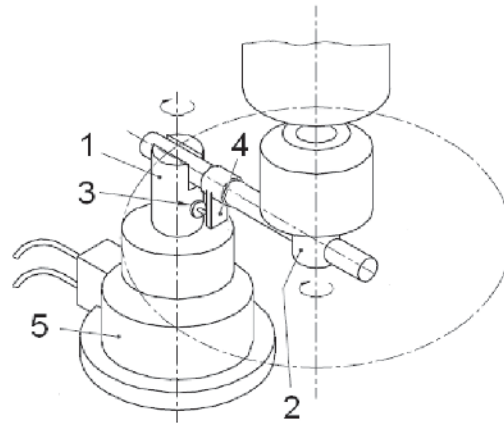

Key

- 1 special rotary fixture 1
- 2 special rotary fixture 2
- 3 one-dimensional linear displacement sensor
- 4 target
- 5 angular encoder

Figure 74 — Circular test using one-dimensional displacement sensor and angular encoder

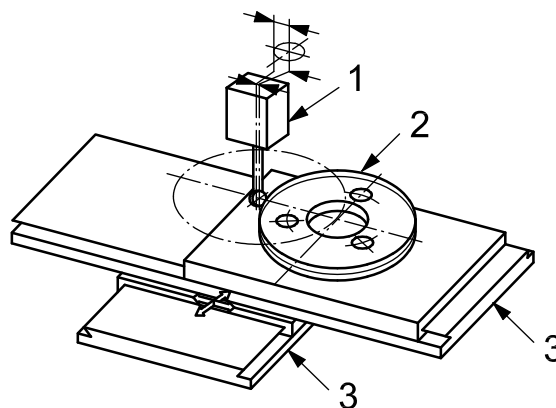

Key

- 1 two-dimensional probe
- 2 circular master
- 3 machine slide(s)

Figure 75 — Circular test using two-dimensional probe

11.3.4.4 Method using telescoping ball bar

One socket or sphere of a telescoping ball bar device is attached to the work holding component of the machine and one socket or sphere to the tool holding component (see Figure 76). The machine is programmed to generate a circular trajectory between the tool side and the workpiece side with a radius equal to the length of the telescoping ball bar. A change in the distance between the two balls is measured. The measurement signal is plotted on a circular diagram (see Figure 72).

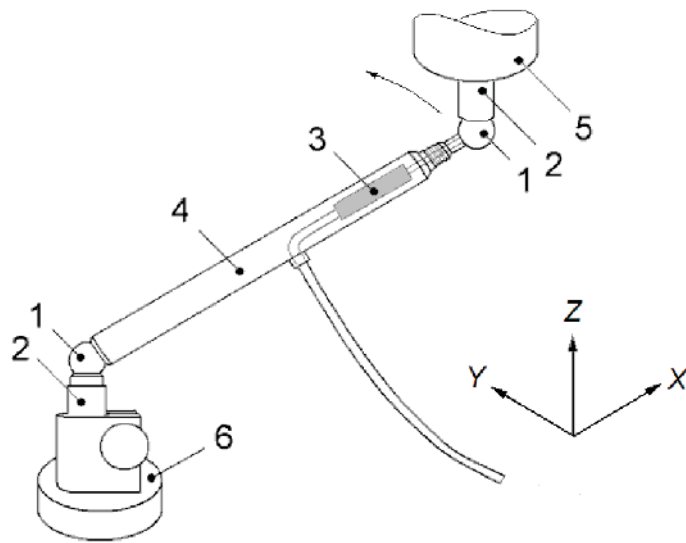

Key

- 1 sphere
- 2 magnetic socket
- 3 linear displacement sensor
- 4 telescoping bar
- 5 machine spindle
- 6 mounting support (table side)

Figure 76 — Circular test using telescoping ball bar

11.3.4.5 Method using two-dimensional digital scale

A digital scale that can simultaneously detect 2-D coordinate positions is used to obtain the series of coordinate positions along the circular trajectory (see ISO/TR 230-11). A 2-D scale position detector is fixed on the tool side and the 2-D scale (grid scale) is placed on the workpiece side (see Figure 77). The coordinate positions along the circular trajectory between the tool side and workpiece side are detected and recorded. Recorded coordinate data are processed (usually by specially designed software) to obtain the circular deviation data, which are plotted on a circular diagram (see Figure 72).

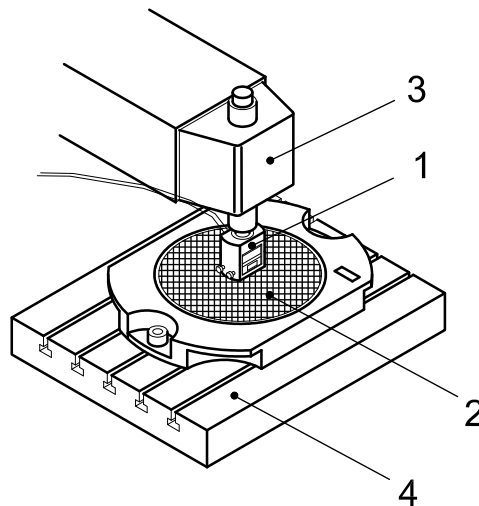

Key

- 1 two-dimensional position detector
- 2 grid scale
- 3 machine spindle head
- 4 machine table

Figure 77 — Circular error measurement using two-dimensional scale

11.3.4.6 Method using two linear displacement sensors and a reference square artefact

A reference square artefact is mounted on the table with its reference surfaces aligned to two machine coordinate axes (X- and Y-axis in the example depicted in Figure 78). Two displacement sensors (aligned to the X-axis direction and Y-axis direction, respectively) are mounted at tool side and placed to detect the relative displacement between the tool side and workpiece side as shown in Figure 78. The X- and Y-axis components of the circular trajectory are continuously detected and recorded by the two linear displacement sensors. Obtained coordinate data (X_n, Y_n) are calculated and the deviations are plotted on a circular diagram (a circular diagram is shown in Figure 72).

The basic calculation is given as Equation (17):

$$X_n^2 + Y_n^2 = (r + e_n)^2 \quad (17)$$

where

X_n, Y_n are the calculated coordinate values at position n ;

r is the programmed circle radius;

e_n are the signed deviations from the programmed circular path. The sign is positive when the deviation is in the direction that increases the circular path radius.

Laser interferometer with two flat mirrors, which are square to each other, can be used for this measurement.

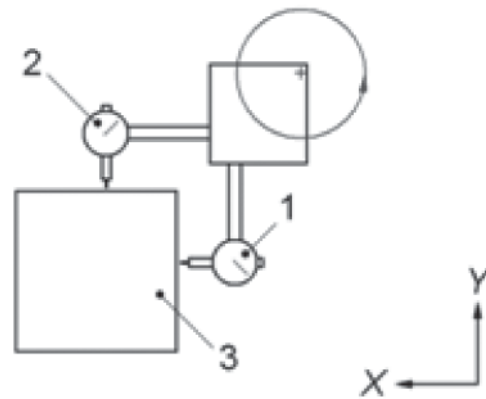

Key

- 1 X-axis linear displacement sensor
- 2 Y-axis linear displacement sensor
- 3 reference square artefact

Figure 78 — Small radius circular error test with two linear displacement sensors

11.3.5 Circular motion generated by any combination of linear and rotary axes

11.3.5.1 General

The purpose of these tests is to check the deviations of the circular or constant radius trajectories generated by any combination of simultaneously controlled (coordinated) three linear and two rotary axes. The basic principle of these tests is to coordinate the multiple axes of motion (combination of rotary and linear axes) to keep the relative position between the tool and the workpiece constant.

The deviations are measured using a spherical artefact with a linear displacement sensor or a multiple sensor nest, or telescoping ball bar.

11.3.5.2 Method using a linear displacement sensor and a spherical artefact

The deviations of the multiple constant radius trajectories around a spherical artefact, generated by any combination of simultaneously controlled (coordinated) three linear and two rotary axes are measured using a linear displacement sensor.

A reference sphere is mounted on the tool holding side and a linear displacement sensor is mounted on the workpiece holding side of the machine tool sensing in a direction perpendicular to the sphere surface (see Figure 82). The displacement sensor output is captured either by a graphic recorder or a computer.

The centre of the programmed sphere of radius, r , shall coincide with the centre of the reference sphere. The reference sphere centre shall be adjusted to be coincident with the spindle axis average line.

11.3.5.3 Method using three linear displacement sensors and a spherical artefact — Radial test

The deviations of the relative position between the tool and the workpiece (along the trajectory generated by the coordinated axes of motion) are measured by three displacement sensors reading against a reference sphere and can be decomposed along the three orthogonal directions (e.g. X, Y and Z or radial, axial and tangential) (see Figure 79).

The reference sphere is centred on the spindle axis average line (tool side) and three linear displacement sensors are mounted on the workpiece side of the machine tool, such that they are aligned to measure the variation in the position of the sphere centre.

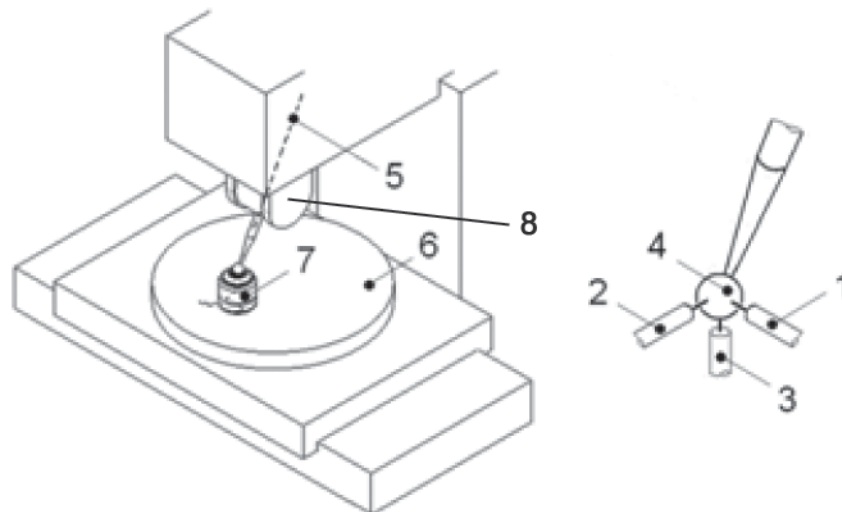

Key

- 1 linear displacement sensor 1
- 2 linear displacement sensor 2
- 3 linear displacement sensor 3
- 4 test sphere centred on spindle axis average line
- 5 spindle axis average line
- 6 rotary table
- 7 sensors nest
- 8 swivel head

Figure 79 — Radial test method with three linear displacement sensors and reference ball — R-test

11.3.5.4 Method using telescoping ball bar

The deviations of the relative position between the tool and the workpiece (along the trajectory generated by the coordinated axes of motion) can be measured with a telescoping ball bar (see Figure 80), where the ball bar can be arranged in three orientations:

- a) parallel to the rotary axis;
- b) radial to the circular trajectory;
- c) tangential to the circular trajectory.

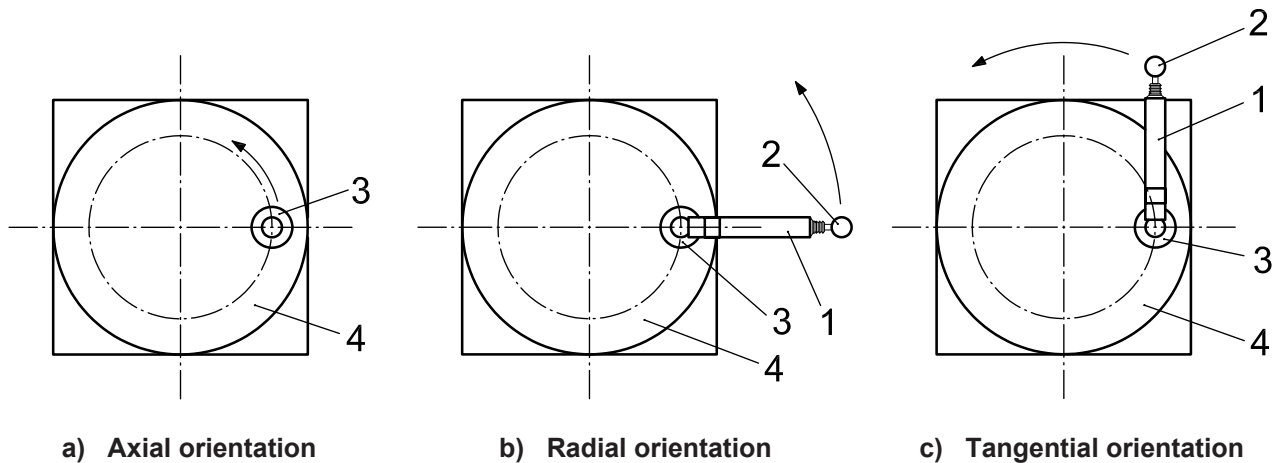

Key

- 1 telescoping ball bar
- 2 sphere socket (spindle side)
- 3 sphere socket (workpiece side)
- 4 rotary table

Figure 80 — Circular motion generated by coordinated two linear and one rotary motion — Measurements in axial, radial and tangential orientations

The table side sphere of the telescoping ball bar is placed at the position away from the axis of rotation of the table and the spindle side sphere is placed on the axis of rotation of the spindle. The axis of the ball bar is set parallel to the table surface in b) and c) and orthogonal to the table surface in a).

The deviations detected by the telescoping ball bar are plotted on a circular diagram corresponding to the rotary axis positions. The circular error of the plotted trajectory is the range of measured deviations.

Other ball bar orientations and tool paths keeping the radial distance between the tool side and the workpiece side constant may also be used to generate circular error diagrams for testing coordination of multiple axes of motion [e.g. conical (shape) motion shown in Figure 81].

11.4 Conical (shape) motion

This method is to check the deviations of the circular tool centre point trajectory generated by simultaneously controlled (coordinated) five axes of motion (three linear and two rotary). Such a motion is programmed (using tool centre programming function of the NC) when machining a conical workpiece. In order to exercise all axes of motion, there shall be an angle, β , between the axis of the cone and the C-axis average line.

For machines with rotary tables, the axis of the cone shall be offset, by a distance, R , from the axis average line of the rotary table at the base of the cone (see Figure 81).

A telescoping ball bar is used to measure the deviations. The spindle side sphere of the ball bar is mounted on the axis of rotation of the spindle, while the table side sphere of the ball bar is mounted to accommodate the above-mentioned offset distance and angle cone axis. For trunnion type rotary tables, it is desirable that the centre position of the table side sphere be higher than the centreline of the A-axis. The telescoping ball bar is set approximately perpendicular to the imaginary conical surface.

Contouring speed shall be constant.

The diameter of the circular trajectory and the inclination angle between the circular trajectory and the table surface, along with the cone apex angle and the C-axis offset shall be noted.

The deviations detected by the ball bar are plotted on the circular diagrams corresponding to the circular trajectory. The difference between the maximum and the minimum recorded values is reported.

Similar tests can be conducted using any combination of four axes of motion. In such cases, the requirement of the offset between the rotary table axis of rotation and the cone axis is relaxed.

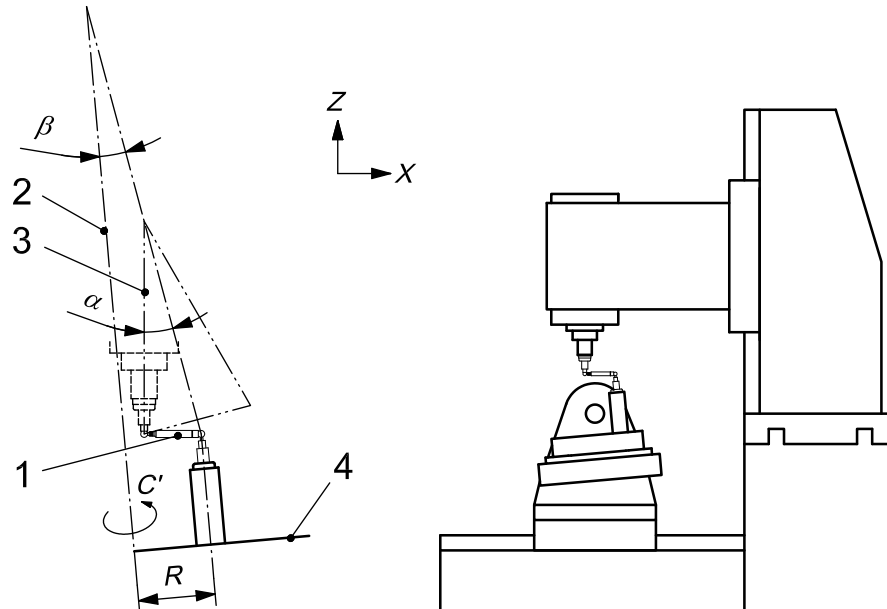

Key

- 1 ball bar
- 2 rotary table axis average line
- 3 spindle axis average line
- 4 rotary table surface
- R offset between the cone axis and the C-axis average line
- α half-apex angle of the cone
- β angle between the axis of the cone and the C-axis average line

Figure 81 — Conical (shape) motion generated by coordinated three linear and two rotary axes

11.5 Spherical interpolation test using spherical artefacts and linear displacement sensors

The purpose of this test is to check the deviations of the multiple constant radius paths around a spherical artefact, generated by any combination of simultaneously controlled (coordinated) three linear and two rotary axes.

This test may be performed using a spherical artefact with linear displacement sensor(s) (see Figure 82) or a multiple sensor nest (see Figure 79), or telescoping ball bar.

The deviations are measured using a spherical artefact with a linear displacement sensor or a multiple sensor nest, or telescoping ball bar.

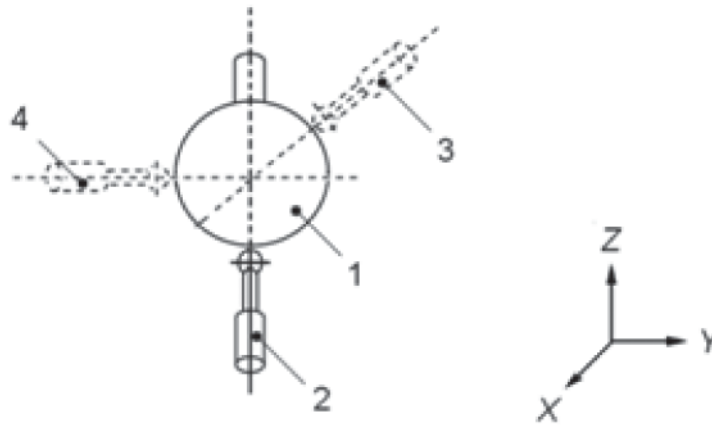

Key

- 1 test sphere centred on spindle axis average line
- 2 linear displacement sensor 1
- 3 linear displacement sensor 2
- 4 linear displacement sensor 3

Figure 82 — Spherical tests

11.6 Flatness error of a surface generated by two axes of linear motion

11.6.1 Method using reference surface plate and linear displacement sensor

The flatness of the virtual surface generated by two linear axes can be measured using a reference planar artefact (surface plate) (see Figure 83). The linear displacement sensor sweeps the reference surface plate by two axes of linear motion. Deviations detected by the linear displacement sensor are recorded and analysed to fit a reference plane (see 3.8.8, 3.8.9 and 3.8.10) and to compute local flatness deviations (see 3.8.7). Flatness error is the range of the computed flatness deviations (see 3.8.11).

NOTE The minimum flatness error is evaluated by using minimum zone reference planes.

11.6.2 Method using a sweeping alignment laser

This method is similar to the one described in 11.6.1. The reference planar artefact (surface plate) is replaced by a sweeping alignment laser, where the laser beam is swept by a rotating mirror to create a plane of laser beam. The linear displacement sensor is replaced by a photodiode sensor (photo-detector) to measure the deviations in the location of the incident beam.

The sweeping laser head is mounted on the machine table (the location where the workpiece would normally be fixtured). The laser head is aligned such that the beam plane is nominally parallel to the virtual surface generated by the two linear axes of motion. The photo-detector is mounted on the spindle (the location where the tool would normally be attached).

Deviations detected by the photo-detector are recorded and analysed to fit a reference plane (see 3.8.8, 3.8.9 and 3.8.10) and to compute local flatness deviations (see 3.8.7). Flatness error is the range of the computed flatness deviations (see 3.8.11).

NOTE 1 The minimum flatness error is evaluated by using minimum zone reference planes.

NOTE 2 In the case of long travel lengths, measurement uncertainty is affected by the spatial variation of the refractive index of air, which strongly contributes to the deflection of the light beam, which deviates from a straight line by about 46 µm in 10 m of travel in a vertical temperature gradient of 1 °C/m (see W.T. Estler *et al.*^[11]). For best results, mixing the ambient air around the laser beam with fans can be considered, in addition to averaging with an adequate number of measurement repetitions.

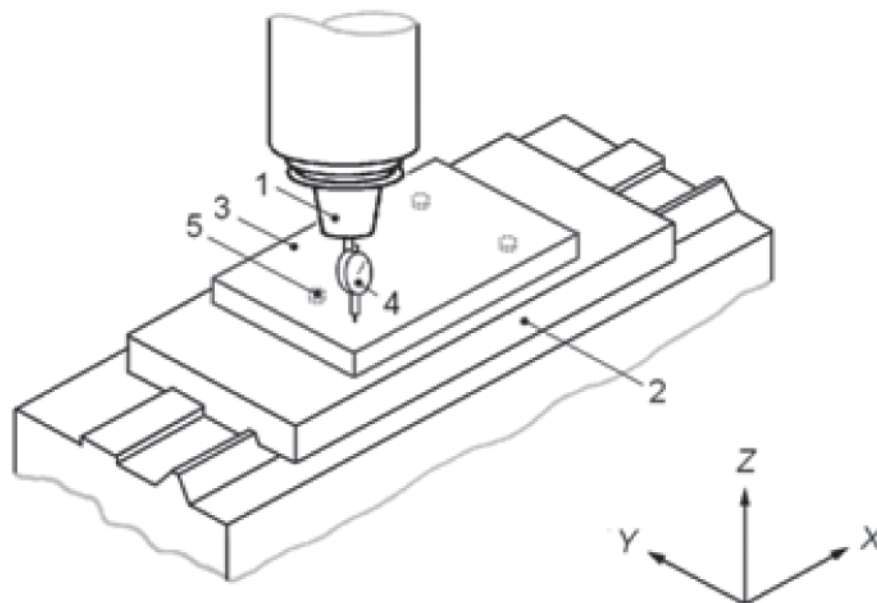

Key

- 1 spindle
- 2 table
- 3 reference surface plate
- 4 linear displacement sensor
- 5 supporting points (3)

Figure 83 — Measurement of flatness deviations by using reference surface plate

11.7 Special tests

11.7.1 General

The tests described in this subclause rely on measurements of multiple distances in machine work volume. These measurements utilize reference artefacts with spheres attached at known positions (1-D, 2-D or 3-D ball arrays) or laser interferometers specially designed for measuring displacements along multiple directions.

In the case of reference artefacts, the positions of the artefact spheres in machine coordinate systems are determined using a displacement measuring or surface detection system in conjunction with the machine scales (hereinafter the “probing system”). The measured positions of the artefact spheres are then compared to the calibrated positions with respect to the artefact coordinate system to determine deviations resulting from the machine error motions.

The measuring instruments for artefact-based measurement are touch-trigger probe, linear displacement sensor(s), nest of linear displacement sensors (for radial test sensor system, see Figure 79), and 2-D and 3-D probes. A repeatability test of the measuring system is recommended before the measurement especially when a touch trigger probe is used.

11.7.2 One-dimensional ball array measurements

The test artefact with balls array may be oriented on the machine table so that the row of spheres is aligned to the desired orientation (see Figure 84).

The qualification of the probing system used, according to ISO 230-10, is recommended.

The exact orientation of the test artefact with respect to the coordinate axes should be measured by measuring the position of the first and last spheres of the artefact with the probing system. With this information, the (target) positions of all spheres of the artefact in the machine coordinate system can be calculated.

During the measurement, the machine axes are moved to the calculated position of each sphere. The deviations resulting from machine error motions and misalignments of the machine axes are measured using the probing system.

After the position of the last sphere has been checked, the first sphere position can be probed again to check for the effect of thermal effects.

The straightness error can be determined from the measured deviations. The values for the positioning accuracy and repeatability can be determined according to ISO 230-2.

11.7.3 Two-dimensional ball array measurements

The calibrated ball array plate may be oriented on the machine table so that the rows and columns of spheres are aligned to two coordinate axes of the machine tool (see Figure 85).

The qualification of the probing system used, according to ISO 230-10, is recommended.

The exact orientation of the ball plate with respect to the machine coordinate axes should be measured by measuring the position of three or four corner spheres of the ball plate with the probing system. With this information, the (target) positions of all spheres of the ball plate in the machine coordinate system can be calculated.

During the measurement, the machine axes are moved to the calculated position of each sphere. The deviations resulting from the machine error motions and misalignments of the machine axes are measured using the probing system.

After the position of the last sphere has been checked, the first sphere position can be probed again to check for the effect of thermal drift.

The position and orientation of the artefact in the machine coordinate frame is mathematically adjusted to minimize the square sum of the range of the machine deviations.

Specific machine errors can be derived redundantly from the measured data, e.g. positioning errors of the individual axes of motion used, straightness errors of these two axes of motion in the ball plate plane, the squareness error between the two axes of motion in the ball plate plane, and one angular error for each of the two axes if the two axes are on the workpiece side of the machine tool.

If the vertical sphere coordinates have also been calibrated, also the straightness in the direction normal to the plane and the angular error motion around the axes of motion (roll) can be measured for the two axes, if the two axes are on the workpiece side of the machine tool.

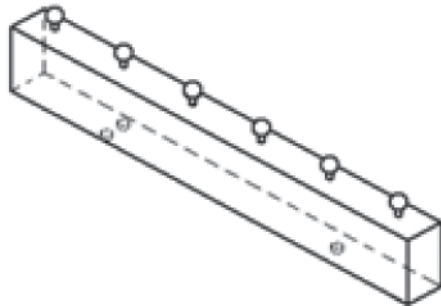

Figure 84 — One-dimensional ball array

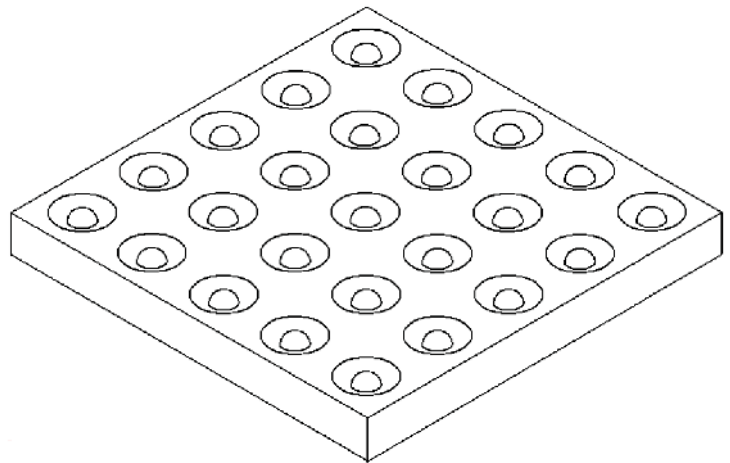

Figure 85 — Two-dimensional ball array

11.7.4 Three-dimensional ball array measurements

These tests can be carried out either using pyramid type 3-D ball arrays or by locating 2-D ball arrays at different heights using calibrated kinematic mounts providing target reference points in machine work volume. Analysis for 2-D measurements is extended using the 3-D data.

11.7.5 Multilateration method with laser interferometer

Multilateration uses a large number of length or position measurements to identify geometric errors in the working volume of a machine tool. The measurements are taken between the tool side and the workpiece side of the machine tool. The machine tool moves over a set of measurement points (e.g. dotted line in Figure 86), and changes in the distance or relative location to a selected point on the workpiece side are recorded. Then, another position of the point on the workpiece side is selected, the machine tool moves again over the same set of measurement points and another set of changes in the distance or relative position are recorded. Several sets of measurements for several selected points are registered. Measurements can be also taken for different offsets on the tool side (see Figure 86).

All measurements are used to evaluate X, Y, Z deviations at the measurement points, or are used (together with a kinematic software model of the machine tool under test) to evaluate positioning error motions, straightness error motions, squareness errors, geometric errors, and roll, pitch and yaw error motions.

The measuring instrument used is, generally, a special laser tracking interferometer that automatically follows the target reflector on the tool side of the machine tool and records the radial displacements and, possibly, the spherical angles when the machine tool moves on the programmed set of measurement points. Sometimes long-range ball bars are used for the length measurement.

The uncertainty of the results depends on the uncertainty of the instrument, environmental influences, repeatability, backlash and hysteresis of the machine tool, the setup of the measurements (positions of selected points on workpiece side and on tool side, number of sets of measurements taken), and on the completeness of the kinematic model of the machine tool used. An uncertainty budget in the classical sense is almost impossible to set up; therefore, evaluation software for multilateration shall give uncertainty values for all evaluated parameters, by using the Monte Carlo simulation method or other appropriate method of uncertainty estimation.

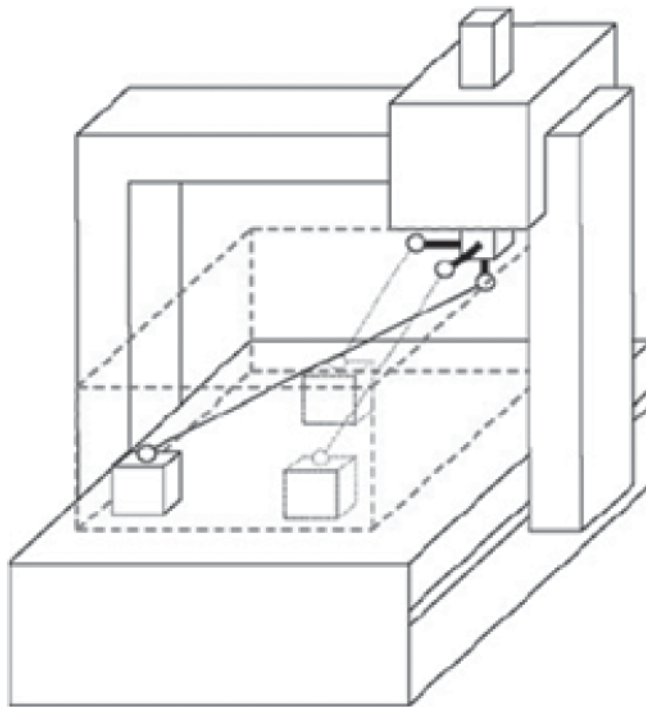

Figure 86 — Multilateration method

12 Geometric accuracy tests of machine functional surfaces — Straightness, flatness, perpendicularity and parallelism

12.1 Straightness error of machine functional surfaces

12.1.1 General

There are two methods for the measurement of straightness deviation, based on the measurement of distance or on the measurement of angles.

The straightness reference can be material artefacts (e.g. straightedge, taut-wire) or natural references (e.g. gravity for a precision level, light beam for laser straightness interferometer, autocollimator and alignment telescope).

12.1.2 Methods based on measurement of distance

12.1.2.1 General

Machine functional surfaces are checked using special metrology carriages and reference artefacts. Linear displacement sensors are mounted on the metrology carriage, which is moving along the surface of interest. The linear displacement sensors sense against the reference artefacts and thus provide straightness deviation values along the surface of interest. Methods described in 8.2.2 are applicable also to the measurement of straightness of machine functional surfaces.

12.1.2.2 Straightedge method

See 8.2.2.1.

12.1.2.3 Taut-wire and microscope method

See 8.2.2.2.

12.1.2.4 Alignment telescope method

See 8.2.2.3.

12.1.3 Methods based on the measurement of angles

12.1.3.1 General

In these methods, a special metrology carriage is in contact with the line to be checked at two points, P and Q, separated by a distance, d (see Figure 87). The metrology carriage is displaced in such a way that in two successive positions, P_0Q_0 , and P_1Q_1 , P_1 is coincident with Q_0 . The angles, α_0 and α_1 , in a plane that contains the measurement line and orthogonal to the surface, are measured using a suitable instrument, such as a level, an autocollimator or a laser angle interferometer.

NOTE 1 The surface between the feet of the metrology carriage is not checked by this method.

Relative differences of distance between subsequent measurement points and the reference of measurement are calculated by Equation (18):

$$E_{h(i+1)} = d \times \tan(\alpha_i) \quad (18)$$

NOTE 2 The reference of measurement is the horizontal level of a precision level or the arbitrarily set reference angle of an autocollimator or laser angle interferometer.

The distances between any measurement points, P_i , and the reference of measurement are given by the Equation (19):

$$E_{P(i+1)} = E_{P_i} + E_{h(i+1)} \quad (19)$$

Points P_i are plotted as shown in Figure 88, a reference straight line is associated to them and straightness deviations and straightness error are evaluated.

The mean minimum zone reference straight line, or the least squares reference straight line, or the end-point reference straight line can be used (see Figures 7, 8 and 9).

The supports, P and Q, of the metrology carriage should be of sufficient area to minimize the effect of minor surface imperfections. It is necessary to prepare the supports very carefully and clean the surface in order to minimize deviations, which can influence the overall measurement.

These methods can also be applied over long distances, but in this case, the d value should be chosen so that a large number of readings and corresponding increase in cumulative errors can be avoided.

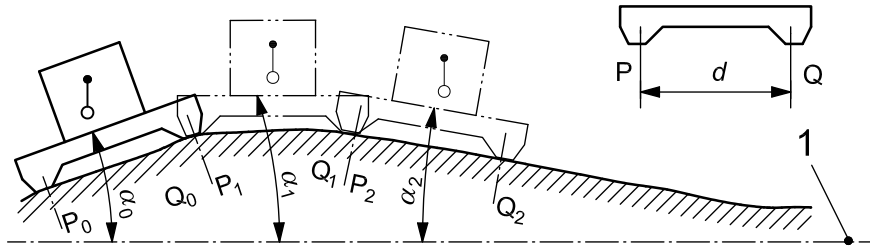

- Key**
- 1 reference of measurement
 - d distance between contact points of the metrological carriage to the surface under test

Figure 87 — Straightness measurement based on measurement of angles

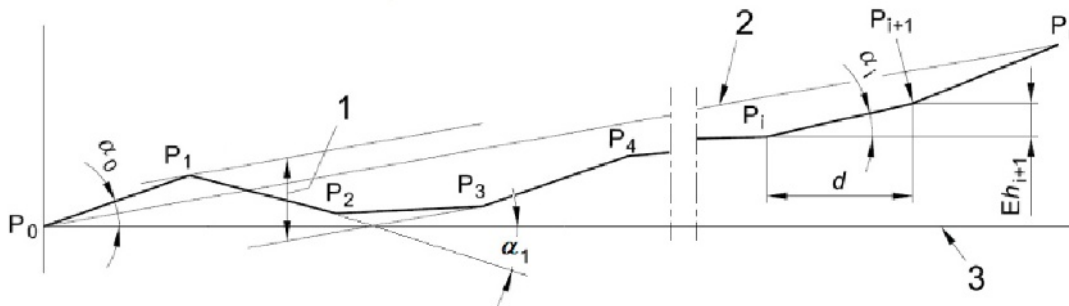

- Key**
- 1 straightness error
 - 2 end-point reference straight line
 - 3 reference of measurement

Figure 88 — Straightness error evaluation based on measurement of angles

12.1.3.2 Precision level method

The measurement instrument is a precision level (see 8.4.2.1 and ISO/TR 230-11) which is positioned successively along the line to be checked as explained in 12.1.3.1. The reference of measurement is the horizontal level of the instrument, which measures small angles in the vertical plane (see Figure 87).

If the line to be measured is not horizontal, the level is mounted on a suitably angled support block (see Figure 88). While checking line AB, the level together with its support should keep a constant orientation [e.g. by means of a guiding straightedge (see Figure 89)].

The level permits checking the straightness only in the vertical plane; for the checking of a line in a second plane another method should be used (e.g. taut-wire and microscope).

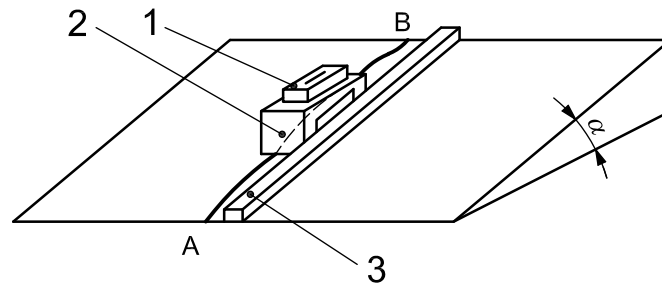

Key

- 1 precision level
- 2 special angled support block
- 3 guiding straightedge
- α angle of the surface from horizontal

Figure 89 — Straightness error measurement along a non-horizontal line using a special angled support block

12.1.3.3 Autocollimation method

In this method, using an autocollimator mounted coaxially (see Figure 90), any rotation of the movable mirror (mounted to a metrology carriage) around a horizontal axis, orthogonal to the optical axis, entails a vertical displacement of the image of the reticule in the focal plane (see 8.4.2.2 and ISO/TR 230-11).

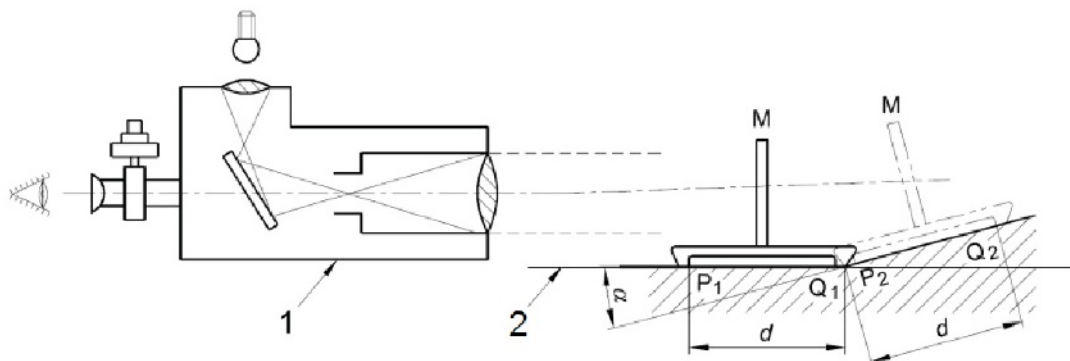

Key

- 1 autocollimator
- 2 reference of measurement
- M movable mirror on metrology carriage
- d distance between the metrological carriage feet

Figure 90 — Straightness measurement using autocollimator

12.1.3.4 Method by laser angle interferometer

In this method, the interferometer should be rigidly fixed to the same component on which the line is to be checked (see Figure 91).

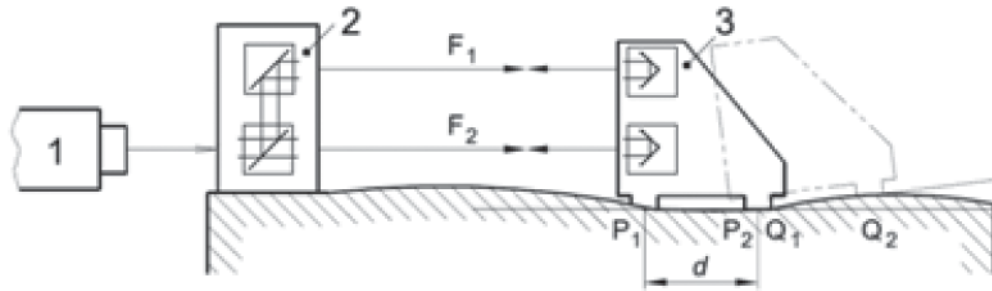

- Key**
- 1 laser source
 - 2 angle interferometer
 - 3 dual retroreflector on metrological carriage
 - d* distance between the metrological carriage feet

Figure 91 — Straightness measurement using laser angle interferometer

12.1.3.5 Sequential three-points method

In this method, one linear displacement sensor supported on a metrological carriage (see Figure 92) is used for detecting the changes in local slope. The distance between the sensor and one of the feet of the metrological carriage should be equal to the distance, *d*, between the feet. The linear displacement sensor measures the elevation of its tip contacting the surface relative to the line through the other two feet, which are also in contact with the surface being measured. After taking a reading, the instrument is moved forward a distance, *d*, equal to the pitch of the feet, and the process is repeated.

At each position, the instrument effectively measures the difference in slope of the lines connecting the surface points beneath its feet. The relative heights of the visited points on the surface are estimated through double integration of the measurements. The linear displacement sensor should be carefully adjusted so that it reads zero when the feet of the instrument are on a straight surface. An error in this adjustment results in a straight surface to be measured as one with a constant radius of curvature.

The elevations of the points along the surface for determination of straightness are calculated using Equation (20):

$$h_i = \sum_{j=1}^{i-2} \sum_{k=1}^j s_k \tag{20}$$

where

h_j is the elevation of the surface at point *j*;

s_j is the reading of the linear displacement sensor at point *j*.

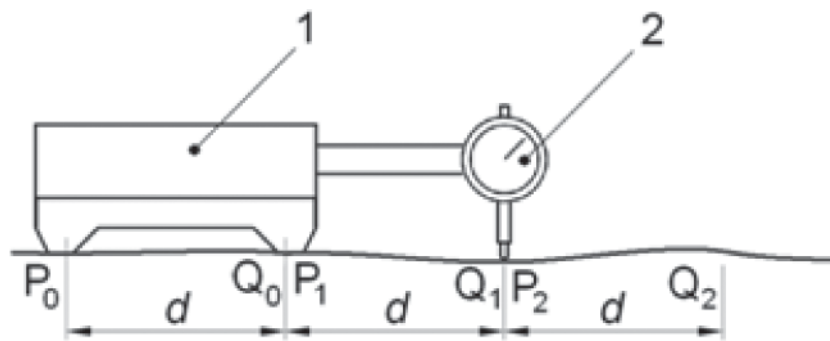

Key

- 1 metrological carriage
- 2 linear displacement sensor
- d distance between the three points of contact

Figure 92 — Straightness measurement using the sequential three-points method

12.1.4 Straightness error of reference grooves or reference surface of tables

In the case of a direct straightness error measurement, the instrument shall read deviations in the normal plane of the line through the points P or Q with h kept to a minimum (see Figure 93).

For such measurements, a metrology carriage shown in Figure 93 is used. The metrology carriage shall lie flat on the table (resting preferably on three localized surfaces, S_1, S_2, S_3) and include two functional bearing surfaces, P and Q, on the line to be checked (see Figure 93). The linear displacement sensor, sensing against a straightedge, shall read deviations in the plane orthogonal to the surface under test, with h kept to a minimum (see Figure 93).

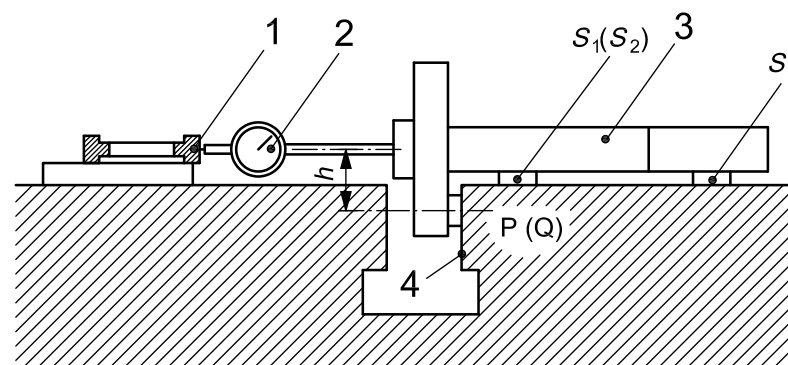

Key

- 1 straightedge
- 2 linear displacement sensor
- 3 metrology carriage (shown also in Figure 93)
- 4 surface under test
- d measuring-point spacing (shown in Figure 94)

Figure 93 — Measurement of straightness error of table reference groove

In the case of straightness measurement based on angular deviations, the distance, d (see Figure 94) defines the measuring-point spacing (see Figure 87).

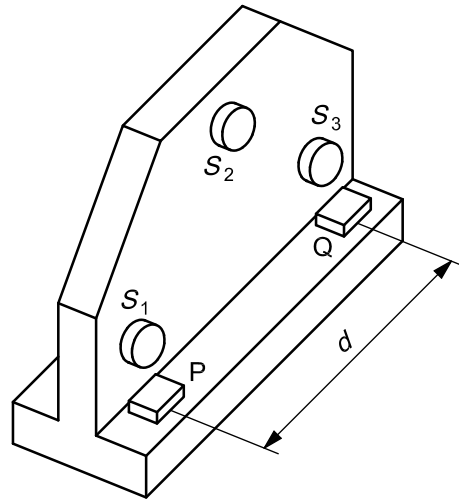

Key
 P, Q contact points (at distance d)
 S_1, S_2, S_3 auxiliary supporting points
 d measuring-point spacing

Figure 94 — Metrology carriage used for measuring straightness error of reference groove

Straightness errors of more complex reference surfaces (see Figure 95) are measured in the functional planes (lines HH and VV) and not square to the surfaces under test.

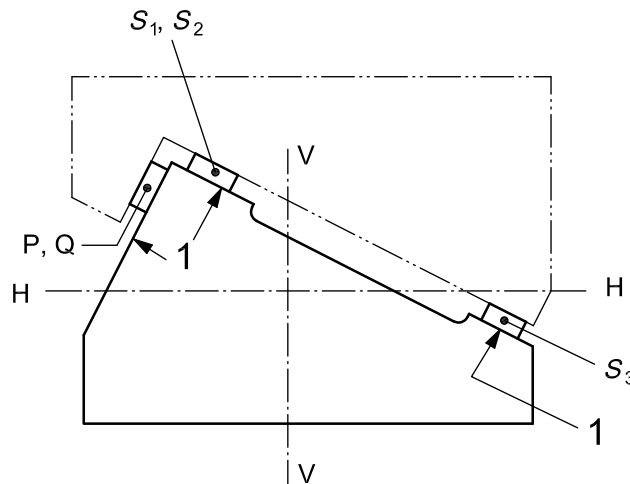

Key
 1 surfaces under test
 P, Q contact points
 S_1, S_2, S_3 contact points

Figure 95 — Functional planes HH and VV for measurement of straightness error of complex surfaces

12.1.5 Straightness error of slideways

The checking of slideways involves the measurement of straightness error and can only be carried out if the functional surface is accessible. If the functional surfaces of the slideway are not accessible, the straightness error of motion should be checked (see 8.2).

The straightness error should always be checked in the functional plane. Generally, this can be regarded as either horizontal (line HH in Figures 95 and 96) or vertical (line VV in Figures 95 and 96) although exceptions may occur with certain machine configurations (see Figure 97).

NOTE 1 The longitudinal shape of a slideway is not necessarily straight as it can present, in the functional plane, a special form specified by the manufacturer.

The guiding surfaces may be composed of the following:

- a) one plane or several small sections joined together;
- b) several narrow plane sections, cylindrical slideways or an assembly of the two.

NOTE 2 Guiding can be ensured by slideways or by more complex devices, which cannot be disassembled without affecting the machine geometry.

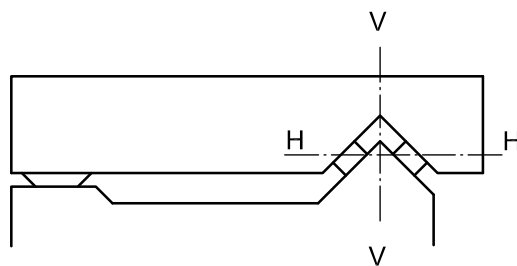
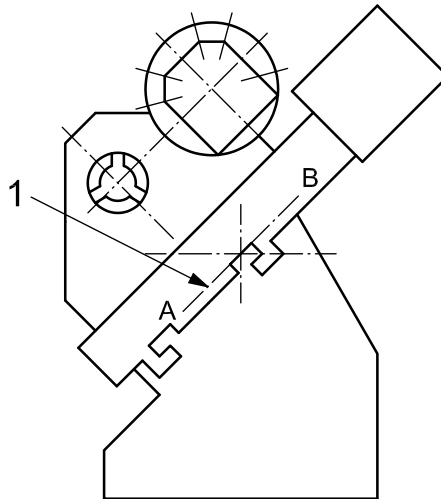

Figure 96 — Functional planes HH and VV for measurement of straightness error of slideways



Key

- 1 functional plane

Figure 97 — Functional plane of slideways on a slant bed machine

12.1.6 Straightness error of V-surfaces

The metrology carriage should bear on the surfaces at four contact points. It shall also be supported by an additional point on a different surface of the slideway for stability.

Figures 98 and 99 show the use of a recessed cylinder and Figure 100 shows an inverted recessed V.

The additional support point should not exert a positioning force on the moving component.

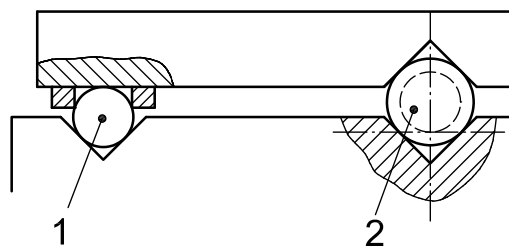

Key

- 1 loose sphere
- 2 recessed cylinder (see Figure 99)

Figure 98 — Metrological carriage and recessed cylinder for measurement of straightness error of V-surfaces

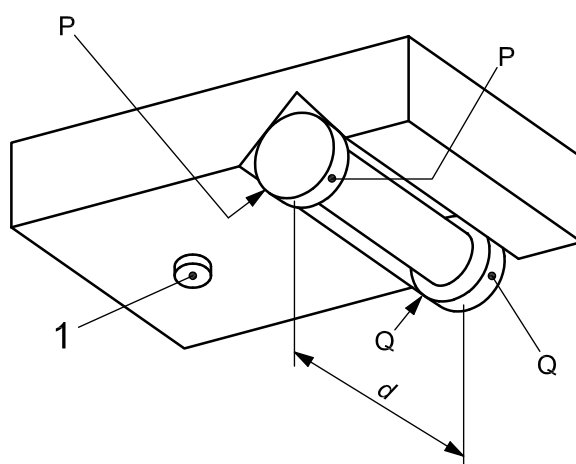

Key

- 1 additional support point
- d distance between the support points
- P, Q support points on cylinder

Figure 99 — The use of recessed cylinder to provide four contact points to measure straightness error of V-surfaces

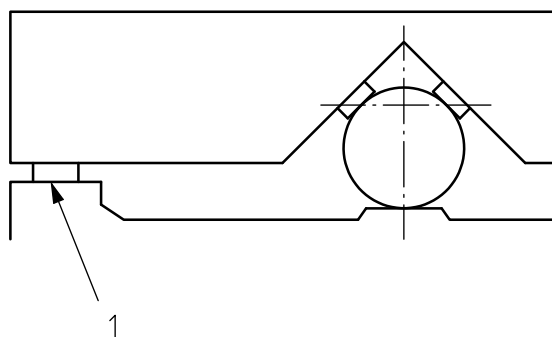

Key

- 1 additional support point

Figure 100 — Metrological carriage for measurement of straightness error of cylindrical surface using inverted V-block

12.1.7 Straightness error of cylindrical surfaces

The metrology carriage on four pads should rest on the cylinder. This is in the form of an inverted V (see Figures 100 and 101).

The additional support point should not exert a positioning force on the moving component.

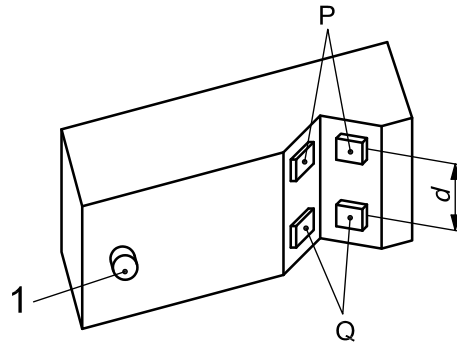

Key

- 1 additional support point
- d distance between the support points
- P, Q support points

Figure 101 — Inverted V-block used for measurement of straightness error of cylindrical surface

12.1.8 Straightness error of single vertical surfaces

The metrology carriage makes contact at two points, P and Q, on the surface being measured. Three additional support points are required to guide it. These should be chosen to ensure guiding without influencing the positioning of the two operational contact points (see Figures 102 and 103).

When the deviations are being measured directly, the instrument should take measurements on the plane normal to the surface and through one of the contact points, and when measuring angular deviations, the distance, d , defines the measurement pitch.

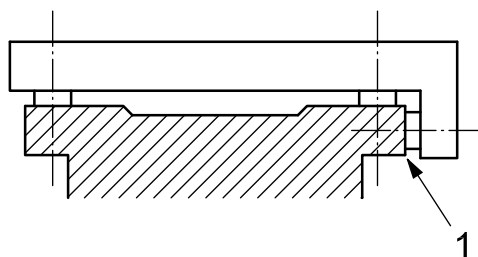

Key

- 1 reference plane

Figure 102 — Use of metrological carriage for measurement of straightness error of vertical surface using a metrology carriage

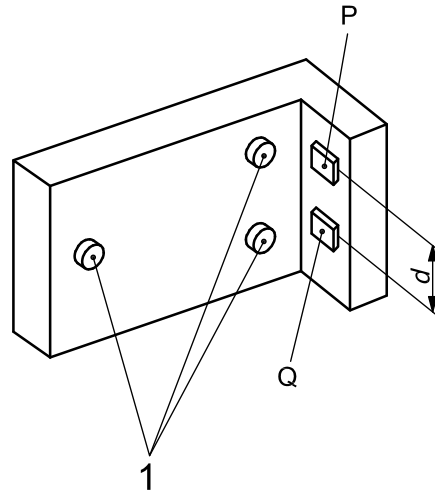

Key

- 1 additional support points
- d distance between the support points

Figure 103 — Metrology carriage used for vertical surfaces

12.1.9 Straightness error of surfaces on slant-bed configuration

In this case, the functional plane of the moving element is at an angle to the horizontal plane (see Figure 97). Straightness error is measured in this functional plane (line AB) and a plane that is normal to it.

12.2 Flatness of machine tables

12.2.1 Measurement of flatness error by means of a surface plate

For assessment of flatness by means of a surface plate, the plate is covered by jeweller's rouge or by chromium oxide diluted in light oil. The surface plate covered in this way is laid upon the surface to be assessed. A slight backward and forward motion is applied. The plate is removed and the distribution of the contact points per surface unit is noted. This distribution should be uniform over the whole area of the surface and should be equal to a given value. The method is applied only to smaller-sized surfaces which present a relatively fine finish (scraped or ground surfaces).

12.2.2 Measurement by means of a surface plate and a linear displacement sensor

The measuring equipment consists of a surface plate and a linear displacement sensor held in a support with a ground base, which moves on the surface plate.

There are two measuring configurations:

- a) the component to be measured is placed on the surface plate (the dimensions of the surface plate and the shape of the linear displacement sensor support shall be large enough to enable all the surface to be measured) (see Figure 104);
- b) the surface plate is placed facing the surface to be measured. In this case, testing is possible with a surface plate whose dimensions are similar to that of the surface to be measured (see Figure 105).

A pattern of squares is established to determine the locations of the measuring points. False readings due to surface defects may be minimized by:

- using a linear displacement sensor with a large radius stylus which is not affected by roughness;

- placing a small ground block with parallel faces between the surface to be measured and the stylus of the linear displacement sensor to absorb the surface defects (scraped surfaces, planed surfaces, etc.).

In the first arrangement (see Figure 104), the position of the linear displacement sensor is influenced by the variation in the slope on the surface of the surface plate. This method should be reserved for highly accurate surface plates. It is not possible to take into account the defects of the surface plate; this method is reserved for small parts.

In the second arrangement (see Figure 105), where measurement is carried out by a linear displacement sensor holder set perpendicularly to the surface plate, it is possible to take into account the defects of the surface plate while processing the results.

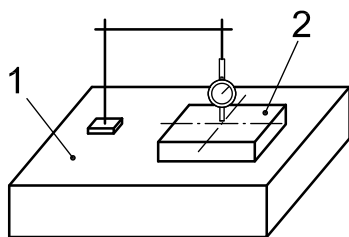

Key

- 1 surface plate (reference of measurement)
- 2 surface to be measured

Figure 104 — Measurement of flatness error of a component located on surface plate

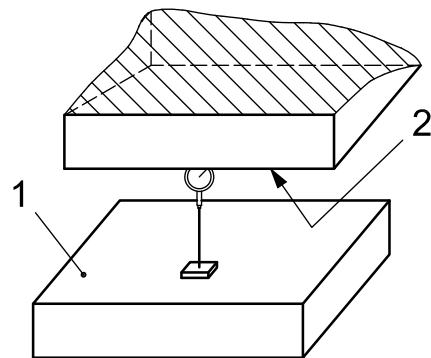

Key

- 1 surface plate (reference of measurement)
- 2 surface being measured

Figure 105 — Measurement of flatness error of a component using an external surface plate

12.2.3 Measurement by means of straightedge(s)

12.2.3.1 Measurement by means of a family of straight lines by displacement of a straightedge

The theoretical plane on which the reference points will be located is first determined. For this purpose, three points, a, b and c, on the surface to be tested are selected as zero marks (see Figure 106). Three gauge blocks of equal thickness are then placed on these three points, so that the upper surfaces of the blocks define the reference plane to which the surface is compared.

A fourth point, d, lying in the reference plane is then selected in the following manner: using gauge blocks which are adjustable for height, a straightedge is placed on a and c and an adjustable block is set at a point, e, on the surface and brought into contact with the lower surface of the straightedge. The upper surfaces of the blocks a, b, c and e are therefore all in the same plane.

The deviation of point d is then found by placing the straightedge on points b and e; an adjustable block is placed at point, d, and its upper face brought into the plane defined by the upper surfaces of the blocks already in position.

By placing the straightedge on a and d and then on b and c, the deviations of all the intermediate points on the surface lying between a and d and between b and c may be found. The deviations of the points lying between a and b, c and d may be found in the same way. (Any necessary allowance for sag in the straight-edge should be made.)

To obtain readings inside the rectangle or square thus defined, it is only necessary to place at points, f and g, for example, the deviations which will then be known, gauge blocks adjusted to the correct height. The straightedge is placed on these, and with the aid of the gauge blocks, the deviation between the surface and the straightedge can be measured. It is possible to use an instrument for the measurement of straightness, as shown for example in Figure 107.

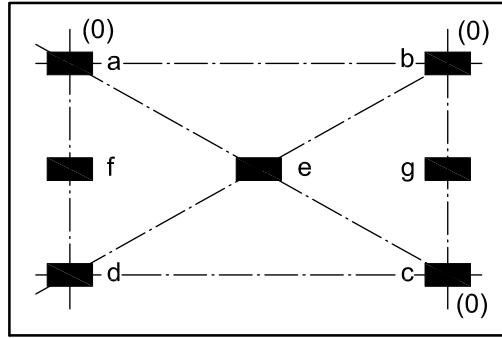
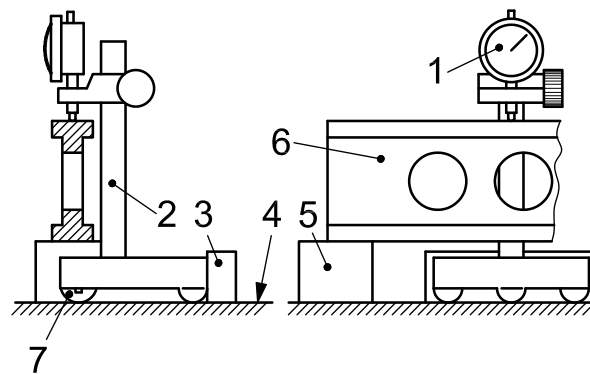

Figure 106 — Flatness error measurements by means of family of straight lines



- Key**
- 1 linear displacement sensor
 - 2 support
 - 3 guiding straightedge
 - 4 surface to be checked
 - 5 parallel block
 - 6 straightedge
 - 7 contact point (1 of 3) aligned with linear displacement sensor stylus

Figure 107 — Straightness measuring instrument used for flatness error measurements

12.2.3.2 Measurement by means of straightedges, a precision level and a linear displacement sensor

In this method, the reference of measurement is provided by two straightedges, which are placed parallel by means of a precision level (see Figure 108) (see ISO/TR 230-11).

Two straightedges, R_1 and R_2 , mounted on rests a, b, c and d, of which three are the same height and one is adjustable, are set up so that their upper rectilinear surfaces are parallel by using a precision level. The two straight lines, R_1 and R_2 , are thus coplanar. One reference straightedge, R , placed on R_1 and R_2 on top of any line, fg, of the square pattern enables the deviations to be read by means of a reading instrument G (or by means of standard gauge blocks).

The straightedges, R_1 and R_2 , shall be sufficiently rigid so that the deflection due to the weight of the reference straightedge is negligible.

A reference of measurement is established and deviations from the reference of measurement are measured and plotted. Plotting may be carried out at different points following a regular pattern of squares (see Figure 109), covering all the surface of the plane to be measured. The choice for spacing the points is independent of the instruments used.

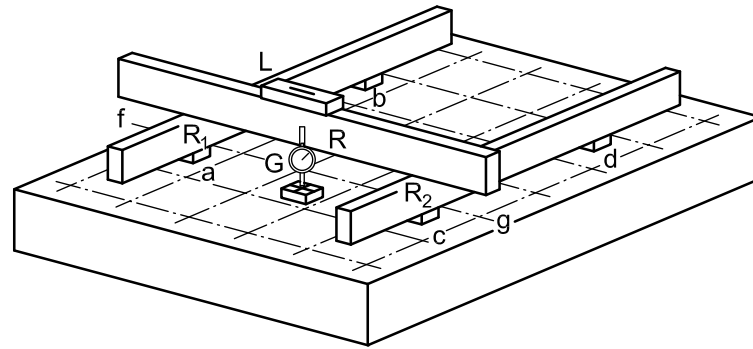

Key

- a,b,c,d supports
- G displacement sensor
- L precision level
- R, R₁, R₂ straightedges
- fg line of measurement

Figure 108 — Flatness error measurement by means of straightedge and level

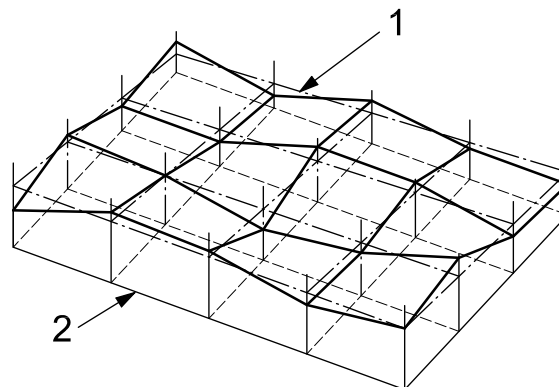

Key

- 1 reference plane
- 2 reference of measurement

Figure 109 — Plot of flatness deviations

12.2.4 Measurement of flatness error by means of a precision level

12.2.4.1 General

This is the only method known at present, which enables a constant direction of measuring reference (horizontal) to be maintained while the instrument is moved from position to position.

Straightness measurement of a line using the angular deviation method (12.1.3) is the basis of this measurement.

For good practice, differential measurements between the moving and the stationary levels are recommended.

12.2.4.2 Measurement of a rectangular surface

The reference plane is determined by two straight lines, OmX and $OO'Y$, where O , m and O' are three points on the surface being checked (see Figure 110).

The lines, OX and OY , are chosen preferably at right angles and if possible parallel to the sides outlining the surface to be measured. Measurement begins in one of the corners, O , of the surface and in the direction, OX . The profile for each line, OA and OC , is determined by the method indicated in 12.1.3.1. The profile of the longitudinal lines, $O'A'$, $O''A''$, and CB is determined so as to cover the whole surface.

Supplementary measurements may be made following mM , $m'M'$, etc., to confirm the previous measurements.

When the width of the surface to be measured is not disproportionate to its length, it is desirable, as a cross-check, to also take measurements along diagonals (see ISO/TR 5460:1985, 8.3, method 8.3.1).

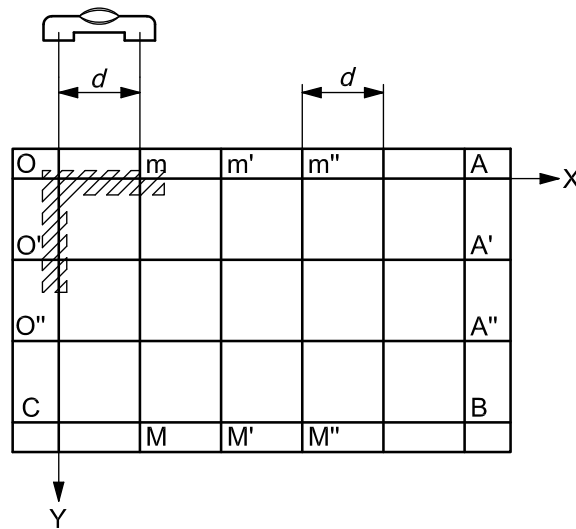

Figure 110 — Measurement of flatness error by means of precision level

12.2.4.2.1 Interpretation of measured results

From the results of measuring lines $Omm'A$ and $OO'O''C$, using the process shown in Figure 87, draw a topographical plotting of $Omm'A$ and $OO'O''C$. For plotting of lines, $O'A'$, $O''A''$ and CB , the starting points shall be O' , O'' and C . In the case of Figure 111, all the plottings are very near to the measuring reference and this plane may be said to be a reference plane, but in the case of Figure 112, reference straight lines of $Omm'A$ and $OO'O''C$ are in the directions OX' and OY' . In such a case, the reference plane would probably be the plane containing OX' and OY' , i.e. plane $OABC$.

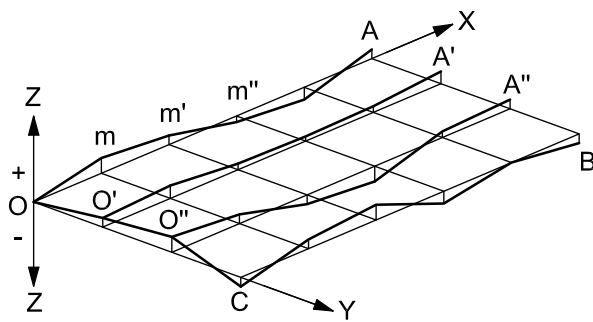

Figure 111 — Flatness deviation data indicating the reference plane close to the measuring reference

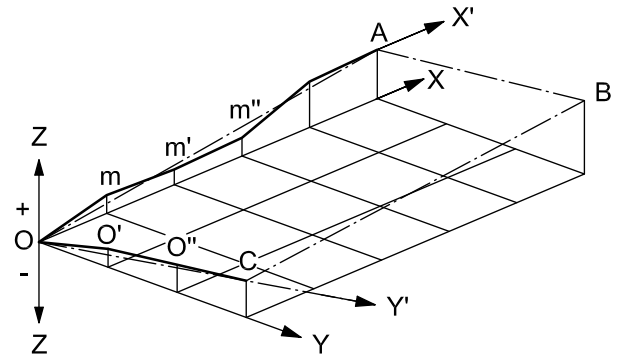

Figure 112 — Flatness deviation data indicating the reference plane different from the measuring reference

12.2.4.3 Measurement of plane surfaces with circular contours

Large plane surfaces, which have circular contours, do not lend themselves to an orthogonal square pattern, which leaves certain parts unchecked. Therefore, it is preferable to carry out the survey using peripheral circles and diameters (see Figure 113).

- Circular verification: a precision level is placed on an isostatic support A and moved at regular intervals around the periphery of the plate.
- Diametrical verification: this is carried out using any method of measuring the straightness of a machine functional surface (see 12.1).

For small surfaces, flatness error measurements are carried out in a simplified way by measuring the straightness:

- of two perpendicular diameters;
- of the sides of the square joining extreme points (see Figure 114).

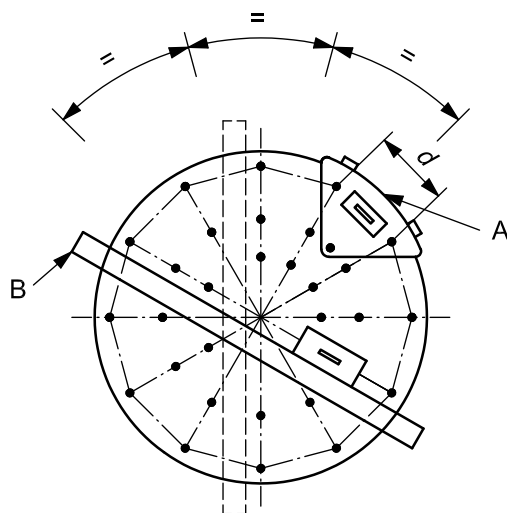

Key

- A isostatic support
- B diametrical guiding straightedge
- d* distance between the support points

Figure 113 — Flatness error measurements along the peripheral circles

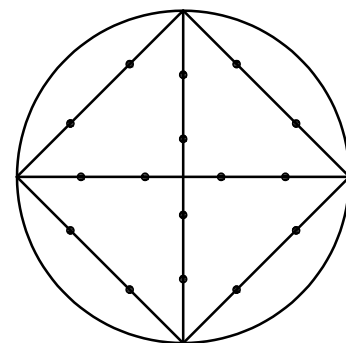

Figure 114 — Flatness error measurement paths for surfaces with circular contours

12.2.5 Measurement of flatness by optical methods

12.2.5.1 Measurement by an autocollimator

Straight lines, OX and OY, defining the reference plane are determined by the optical axis of the autocollimator in two positions and, if possible, at 90° to each other. The method given in 12.1.3.3 is then followed.

The reference plane of measurement is determined by the directions of the optical axes of the autocollimator, OX and OY. Thus, for the measurements of O'A', O''A'' and CB, the optical axis of the autocollimator shall be parallel to OX (see Figure 110) (see ISO/TR 5460:1985, 8.4, method 8.4.1).

12.2.5.2 Measurement by a sweep optical square

Alternatively, a sweep optical square (pentagonal prism) is used. The reference plane is established by the centres of the three datum targets (A, B and C) placed at the periphery of the surface (see Figure 115).

The square is aligned so that the telescope optical axis is perpendicular to the reference plane and a fourth target is used to measure the position of any point on the surface (see ISO/TR 230-11).

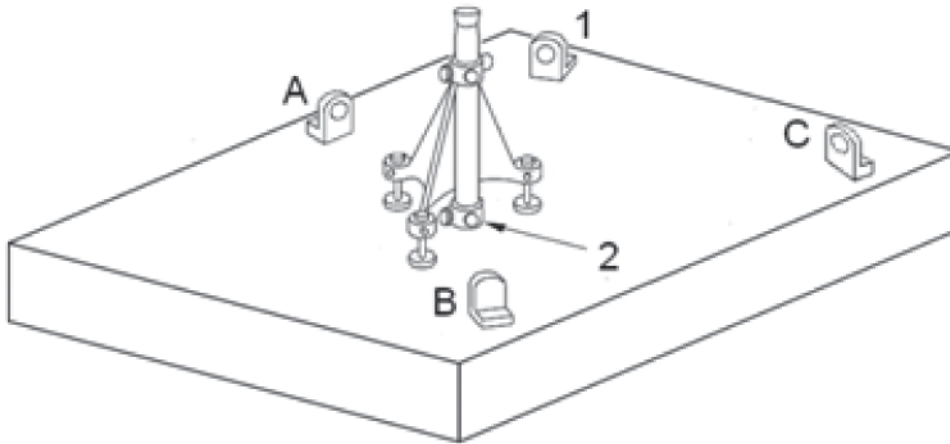

Key

- 1 measuring target
- 2 sweep optical square (pentagonal prism)
- A,B,C datum targets

Figure 115 — Measurement of flatness error using sweep optical square

12.2.5.3 Measurement by a sweeping alignment laser

In this method, a rotating (sweeping) unit is used in association with an alignment laser to define a plane of reference for the measurement with the aid of various coplanar rectilinear references (see Figure 116 and ISO/TR 230-11).

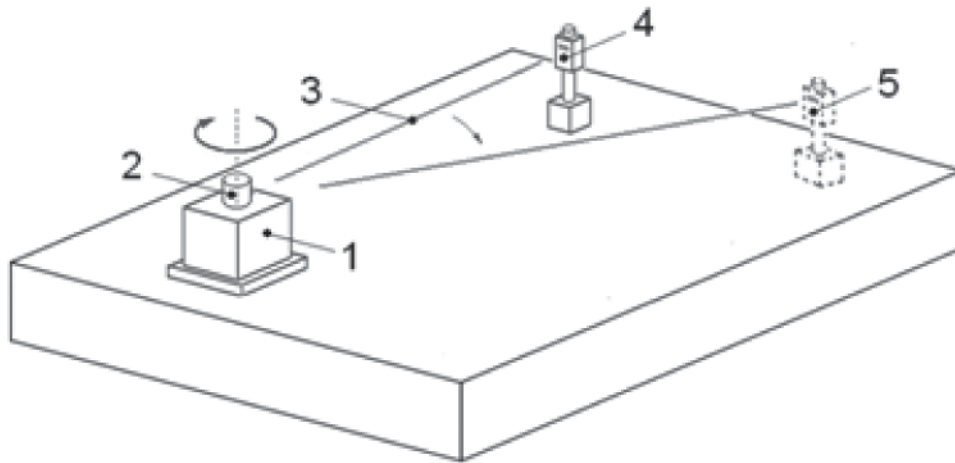

Key

- 1 alignment laser head
- 2 rotating unit
- 3 sweeping laser beam
- 4 photosensitive target in measuring position „
- 5 target in different measuring position over the surface being tested

Figure 116 — Measurement of flatness error using sweeping alignment laser

12.2.5.4 Measurement by a laser interferometer system

The topography of a surface is reconstituted from the examination of the straightness of different lines by measuring angular deviations (see ISO/TR 230-11).

A typical sequence of measurement is shown in Figure 117, where lines 1 to 8 are illustrated diagrammatically.

Successively, lines 1 to 8 are checked. The resulting readings analysed by data processing give a plot of surface-plate flatness in isometric form (see Figure 118).

The laser beam is horizontally adjusted in the desired direction by adjusting the turning mirror. This, however, can affect the vertical direction of the laser beam.

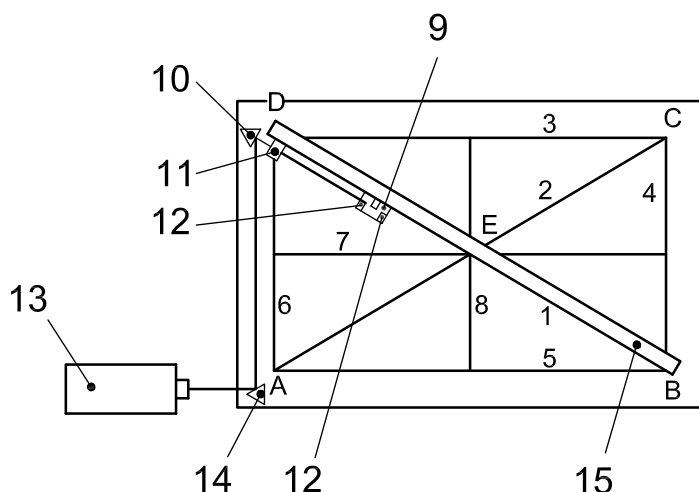

- Key**
- 1 to 8 lines of measurement
 - 9 retroreflector
 - 10 2nd turning mirror
 - 11 interferometer
 - 12 retroreflector support
 - 13 laser head
 - 14 1st turning mirror
 - 15 guiding straightedge

Figure 117 — Measurement of flatness error using laser interferometer

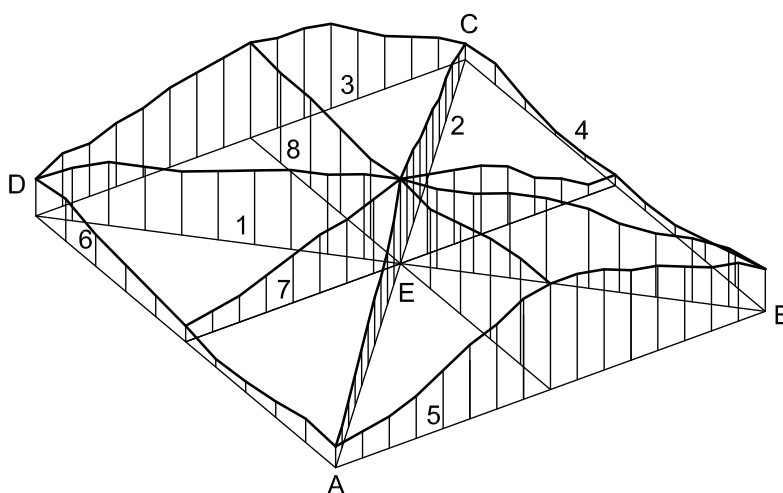

- Key**
- 1 to 8 lines of measurement

Figure 118 — Typical plot of flatness deviations data

12.3 Position and orientation of functional surfaces

12.3.1 General

These measurements address the following features:

- a) parallelism of lines and planes, see 12.3.2 (see ISO/TR 5460:1985, Clause 13);
- b) equidistance, see 12.3.3;

c) coaxiality, see 12.3.4 (see ISO/TR 5460:1985, Clause 18).

12.3.2 Parallelism of lines and planes

12.3.2.1 General

Where measurement of parallelism involves axes, the axes themselves shall be represented by cylindrical surfaces of high precision of form, suitable surface finish and sufficient length. If the surface of the spindle does not fulfil these conditions or if it is an internal surface and will not admit a feeler, an auxiliary cylindrical surface (test mandrel) is used.

Fixing and centring of the test mandrel shall be done on the end of the shaft or in the cylindrical or conical bore designed to take the tool or other attachments. When inserting a test mandrel on the spindle axis so as to represent an axis of rotation, allowance shall be made for the fact that it is impossible to centre the mandrel exactly on the axis of rotation. When the spindle is rotating, the axis of the mandrel describes a hyperboloid (or a conical surface, if the axis of the mandrel intersects the axis of rotation) and gives two positions B-B' lying in the plane of test (see Figure 119).

The measurement of parallelism may, under these conditions, be effected at any angular orientation of the spindle, but should be repeated after rotating the spindle through 180°. The algebraic mean of the two readings gives the deviation of parallelism in the given plane.

The mandrel may also be brought into the mean position A (called “mean position of run-out”); the measurement should then be effected in this position only.

The first method seems to be as quick as the second and is more accurate.

NOTE The term “mean position of run-out” is understood as follows: a gauge stylus is brought into contact, in the plane of test, with the cylindrical surface representing the axis of rotation. The reading of the measuring instrument is observed as the spindle is slowly rotated. The spindle is in the mean position of run-out when the pointer gives a mean reading between the two ends of its stroke.

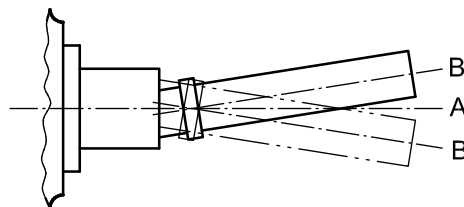

Key

- A axis of rotation
- B axis of mandrel at 0°
- B' axis of mandrel at 180°

Figure 119 — Influence of alignment of test mandrel with respect to axis of rotation

12.3.2.2 Parallelism of two planes

12.3.2.2.1 General

The following methods can be used to verify the parallelism of two planes. The measurements should be carried out in two directions, preferably perpendicular to each other.

A line (or plane) is measured within a given length (or area) (e.g. on 300 mm or on 300 mm × 300 mm) or over the entire surface.

The angle between lines (or plane) may be evaluated in given planes (horizontal, vertical, perpendicular to the examined surface, crossing the examined axes, etc.). The tolerance of parallelism may be different in different planes.

12.3.2.2.2 Measurements using straightedge and linear displacement sensor

The linear displacement sensor, mounted on a support with a flat base and guided by contact with the straightedge, is moved on one plane by the amount specified. The stylus slides along the second plane (see Figure 120).

The readings (variations of distances) are graphically plotted and the resulting reference straight line is evaluated. The inclination of this reference straight line represents the angle deviation between the examined planes in the given direction.

Generally the measurement may be taken at both ends of the measuring range only. The angle deviation (tangent) is determined from both the difference of these two readings and the measuring length.

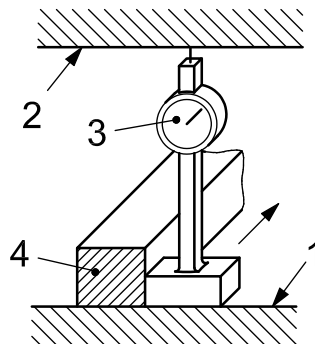

- Key**
- 1 reference (datum) plane
 - 2 referred plane
 - 3 linear displacement sensor
 - 4 guiding straightedge

Figure 120 — Measurement of parallelism error between two planes using straightedge and displacement sensor

12.3.2.2.3 Measurement using precision level

The level is supported on a carrier which bridges the two planes to be compared. A succession of readings is taken along the planes. The readings multiplied by d (see Figure 121) give the relative deviation of the two planes which is used to determine the reference straight line. The orientation of the reference straight line (angle) is the parallelism error.

If it is difficult to bridge the two planes, the carrier is not used and readings are taken along each plane with the horizontal used as the measuring reference (12.1.3). The two reference straight lines are evaluated according to 12.1.3. The difference in their orientation (angle) is the parallelism error.

12.3.2.3 Parallelism of two axes

12.3.2.3.1 General

The measurement is made in two planes:

- in a plane passing through two axes;

NOTE This expression means a plane passing through one of the two axes and as near as possible to the second axis.

— then in a second plane perpendicular, if possible, to the first.

12.3.2.3.2 In a plane passing through two axes

The measuring instrument is held on a support with a base of suitable shape, so that it can slide along a cylinder representing one of the two axes; the stylus slides along the cylinder representing the second axis.

To determine the minimum reading between the axes at measuring points, the instrument shall be gently rocked in a direction perpendicular to the axes (see Figure 122). If necessary, the deflection of the cylinder under the weight it has to support during measurement may be taken into consideration (see ISO/TR 5460:1985, 13.2, method 13.2.1).

12.3.2.3.3 In a second plane perpendicular to the first

This measurement method requires an additional plane, if possible parallel to that passing through the two axes.

If this additional plane exists, by virtue of the fact that the two axes are parallel to a machine functional surface, the parallelism of each axis, considered separately, shall be determined in relation to this surface in the manner described in 12.3.2.4. If not, the measurement should be made with reference to a theoretical plane by means of a level with an adjustable glass tube. For this purpose, the latter should be placed on the two cylinders representing the axes and the air-bubble set to zero. If the two axes are not in the same horizontal plane, an auxiliary block, fixed or adjustable, may be used (see Figure 123).

The level is moved along the axes by the amount specified and readings taken. The readings are multiplied by the distance between the axes. If, for example, this distance is 300 mm and the level reading is 0,06 mm/1 000 mm, the relative deviation between the two axes is $0,06 \times 0,3 = 0,018$ mm. These relative deviations are used to determine the reference straight line. The orientation of the reference straight line (angle) is the parallelism error.

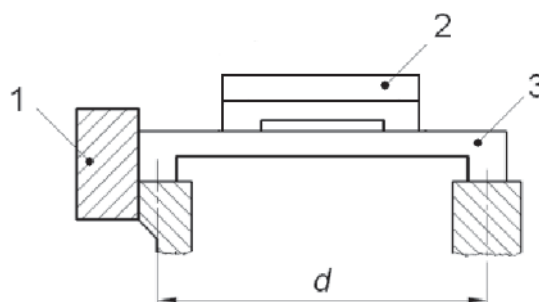

Key

- 1 guiding straightedge
- 2 precision level
- 3 carrier
- d* measurement base length

Figure 121 — Measurement of parallelism error using precision level

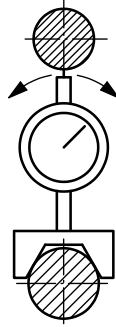

Figure 122 — Measurement of parallelism error of two axes in the plane passing through both axes

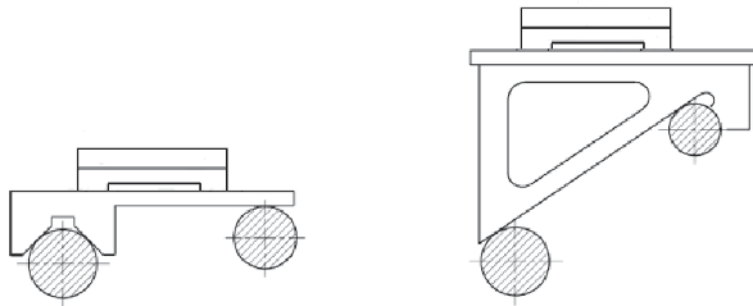

Figure 123 — Auxiliary blocks used for the measurement of parallelism error of two axes

12.3.2.4 Parallelism between an axis and a plane

The measuring instrument is held on a support with a flat base and moved along the plane by the specified amount. The stylus slides along the cylinder representing the axis (see Figure 124).

At each point of measurement, the minimum reading is found by slightly moving the measuring instrument in a direction perpendicular to the axis.

In the case of a pivoting axis, measurement in the mean position and the two extreme positions is sufficient (see Figure 125).

NOTE For the representation of an axis by a cylindrical surface, see 12.3.2.1.

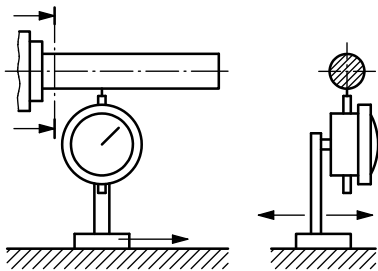

Figure 124 — Measurement of parallelism error between an axis and a plane

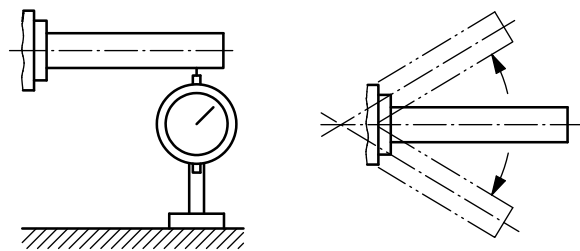

Figure 125 — Measurement of parallelism error between a pivoting axis and a plane

12.3.2.5 Parallelism between an axis of linear motion and a plane

12.3.2.5.1 Measurement where the plane is on the moving component itself

The displacement transducer shall be attached to a fixed component of the machine and the stylus shall bear at right angles to the surface to be measured.

The moving component should be moved by the amount stated, e.g. in machine-specific International Standards.

This type of measurement is typically applied on milling and grinding machines where the workpiece is mounted on a work table.

The displacement transducer shall be mounted in the spindle nose, as shown in Figure 126 and the table traversed. The resulting readings shall be used to determine the reference flat plane. The orientation (angle) of the reference flat plane shall be the parallelism error.

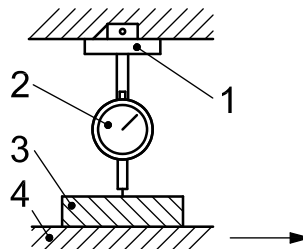

Key

- 1 machine spindle head
- 2 linear displacement sensor
- 3 block or slip gauge (optional)
- 4 moving table

Figure 126 — Measurement of parallelism error between an axis and a moving plane

12.3.2.5.2 Measurement where the plane is not on the moving component itself

The measuring instrument shall be attached to the moving component and moved with it by the amount stated; the stylus shall be at right angles to the surface and slide along it (see Figure 127).

If the stylus cannot bear directly on the surface (e.g. the edge of a narrow groove), the following two alternative methods may be used:

- use of angle lever attachments (see Figure 128);
- use of an artefact of suitable shape (see Figure 129).

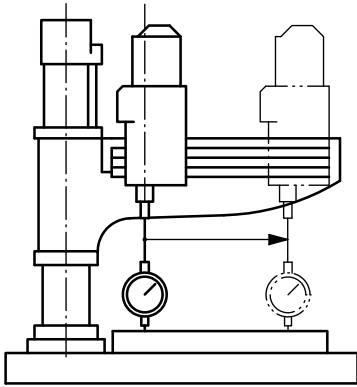

Figure 127 — Measurement of parallelism error between an axis and non-moving plane

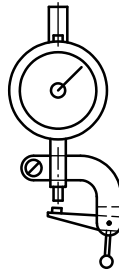

Figure 128 — Angle lever attachment used in parallelism error measurements

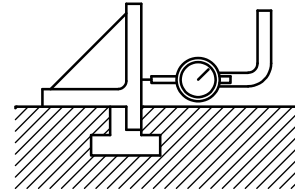

Figure 129 — Special artefact used in parallelism error measurements

12.3.2.6 Parallelism between an axis and the intersection of two planes

The measuring instrument is held on a support with a base of suitable shape resting on the two planes. The instrument is then moved the specified distance along the straight line of intersection and the stylus slides along the cylinder representing the axis (see Figure 130). The measurement shall, as far as possible, be made in two perpendicular planes chosen as being of greatest importance in the operation of the machine tool.

NOTE For the representation of an axis by a cylindrical surface, see 12.3.2.1.

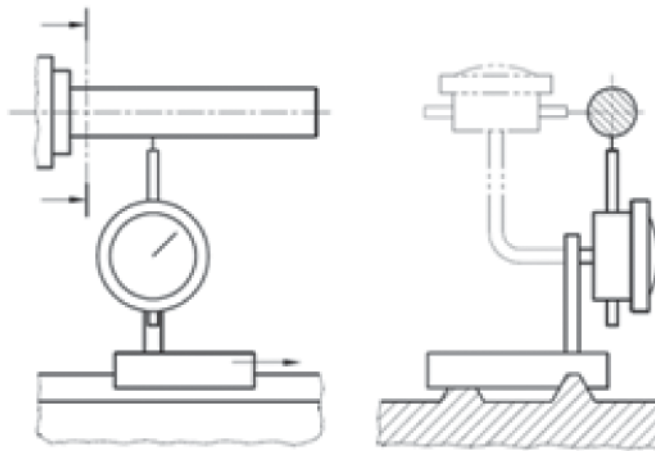

Figure 130 — Measurement of parallelism error between an axis and the intersection of two planes

12.3.2.7 Parallelism between an axis of motion and the intersection of two planes

Parallelism between each of the two planes and the trajectory of functional point shall be measured separately, according to 12.3.2.5. The position of the intersecting line shall be deduced from the position of the planes.

12.3.2.8 Parallelism between the intersection of two planes and a third plane

Where the intersection and the third plane are conveniently situated to one another, a mounting block and precision level are used (see Figure 131).

The assembly is moved along the intersection and changes in the angular readings multiplied by d are calculated. These deviations are used to determine the reference straight line and the parallelism error (see 12.3.2.2.3).

Where the intersection and the third plane are conveniently situated to one another, a mounting block and precision level are used (see Figure 131). The assembly is moved along the intersection and the readings are taken. For the evaluation of parallelism, see 12.3.2.2.3.

If the third plane is not conveniently situated, a mounting block and linear displacement sensor are used (see Figure 132). The stylus is positioned at right angles to the third plane and a succession of readings is taken along the line of the intersection. For other measurement procedures, see 12.3.2.2.2.

The included angle between the location faces of the mounting block shall be accurately matched to the intersection angle of the two planes. This can be verified with a marking agent, such as jeweller's rouge.

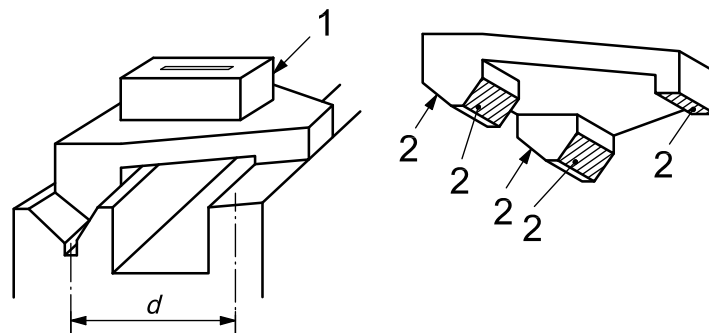

Key

- 1 precision level
- 2 location faces
- d measurement base length

Figure 131 — Measurement of parallelism error between the intersection of two planes and a third plane

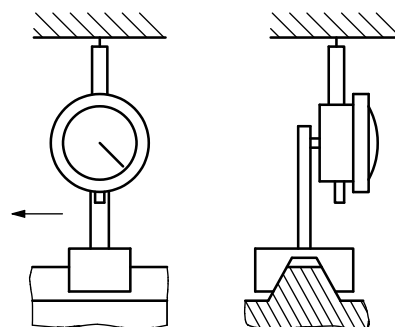

Figure 132 — Measurement of parallelism error between the intersection of two planes and a third plane across from the first two

12.3.2.9 Parallelism between two straight lines, each formed by the intersection of two planes

This measurement may be carried out as in 12.3.2.6.

The stylus of the measuring instrument bears on a V-block, which slides along the planes forming the second intersection. The measurement shall be made in two planes perpendicular to one another (see Figure 133).

This method requires very rigid mounting of the measuring instrument, a condition, which can be observed only in the case of two straight lines close to each other. To improve the rigidity of the measurement setup, a level should be used, as shown in Figure 134, for the measurement of parallelism in a vertical plane. The two setups depicted in Figures 133 and 134 may provide different measurement results.

If a direct measurement of the planes or straight lines concerned is difficult because of interference by components of the machine tool within the field of measurement, the measurement may be related to a reference plane constituted by, for example, a horizontal plane determined by a precision level.

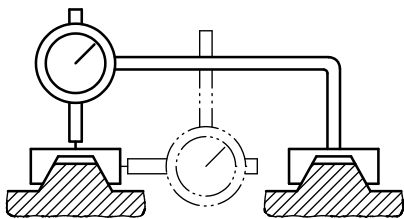

Figure 133 — Measurement of parallelism error between two straight lines formed by intersection of two planes (using linear displacement sensors)

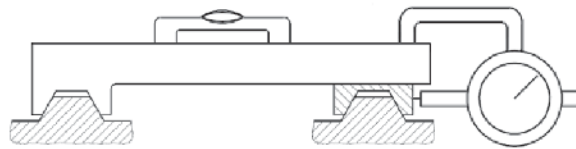

Figure 134 — Measurement of parallelism error between two straight lines formed by intersection of two planes (using level for vertical direction and displacement sensor for horizontal direction)

12.3.3 Equidistance of two axes

12.3.3.1 General

The equidistance is identical with that of parallelism between a plane passing through the axes and a reference plane.

Tests for equidistance of two axes, or of a rotating axis, from a plane are, in effect, measurements of parallelism (see 12.3.2.4). A test should first be made to check that the two axes are parallel to the plane, and then, that they are at the same distance from this plane, by using the same linear displacement sensor on the two cylinders representing the axes (see Figure 135).

If these cylinders are not identical, the difference of radius of the tested sections should be taken into account.

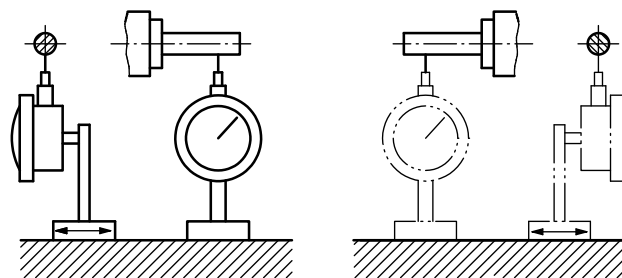

Figure 135 — Measurement of equidistance of two axes

12.3.3.2 Special case of the equidistance of two axes from the plane of pivoting of one of the axes

It is possible for the plane of pivoting of the part carrying one of the axes to not be accessible and to not allow movement of the measuring instrument. It would then be necessary to construct an additional plane parallel to the plane of pivoting (see Figure 136).

The setting and fixing of this auxiliary plane should be carried out so that, when a level is placed on it, if possible in two perpendicular directions, there is no deviation during the pivoting motion of the component. The equidistance of the axis (in its middle as well as in its extreme positions) is then tested, as well as that of the fixed axis, in relation to the auxiliary plane.

When either a horizontal or oblique auxiliary plane is used, it is recommended that the linear displacement sensor be set in its original place to ensure that no abnormal displacement has taken place when pivoting.

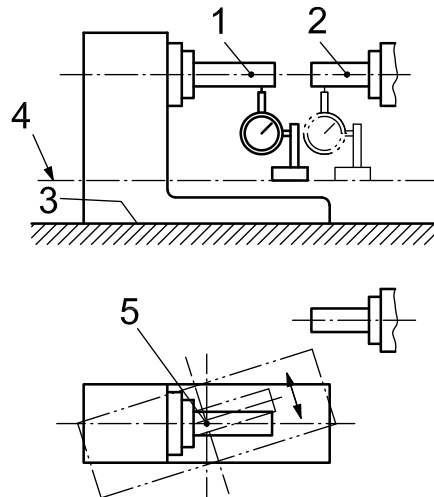

Key

- 1 first axis
- 2 second axis
- 3 pivoting plane
- 4 auxiliary plane
- 5 pivot

Figure 136 — Measurement of equidistance of two mandrels (representing axes) from the plane of pivoting of one axis

12.3.4 Coaxiality

If the measuring instrument is required to rotate around a fixed mandrel, it should be mounted on a ring rotating with a minimum amount of play. This ring should be of sufficient length to ensure that the reading is not affected by the clearance in the ring (see Figure 137).

The linear displacement sensor is attached to an arm and rotates through 360° around the first surface. The stylus of the displacement sensor passes in a given section A over the cylinder representing the second surface to be checked (see Figure 137). Any variation in the readings represents twice the deviation of coaxiality. As the section chosen for measuring may intersect both axes, the check shall be made in a second section B.

If the error is to be determined in two specified planes (e.g. planes H and V in Figure 137), the variations found in those two planes shall be separately recorded.

It is necessary, particularly in the case of horizontal axes, to have very rigid mountings. When high accuracy is required, two measuring instruments offset by 180° shall be used simultaneously in order to eliminate the effect of deflection. Alternatively, a support shall be used, the deflection of which is negligible under a weight double that of the linear displacement sensor used.

Linear displacement sensors of very light weight shall be used in these tests.

Since the direction of the measurement varies during rotation in relation to the direction of gravity, the sensitivity of the measuring instruments to the force of gravity shall be taken into account.

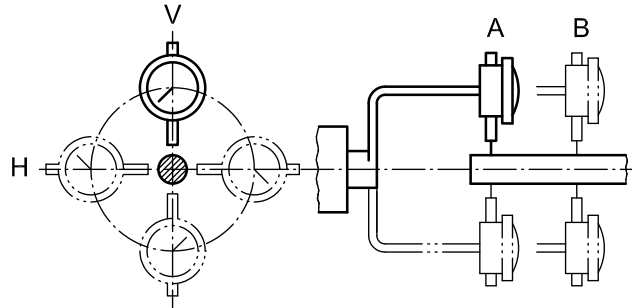

Figure 137 — Measurement of coaxiality error between two axes

12.4 Squareness error and perpendicularity error between lines and planes

12.4.1 General

Squareness error involves axes of linear motion or axes of rotation: it is an angle. Perpendicularity error refers to functional surfaces: it is a distance. The measurement of squareness error and perpendicularity error is, in practice, the measurement of parallelism error. The following general statements apply.

For an axis of rotation, the following method may be used. An arm carrying a linear displacement sensor is attached to the spindle and the stylus of the gauge adjusted parallel to the axis of rotation. As the spindle revolves, the linear displacement sensor describes a circumference, the plane of which is perpendicular to the axis of rotation. The parallelism error between the plane of the circumference and the plane may be measured by sweeping the plane to be checked by means of the stylus of the linear displacement sensor.

This error is expressed in relation to the diameter of the circle of rotation of the instrument (see Figure 138).

- a) If no test plane is specified, the linear displacement sensor is rotated through 360° and the largest variation in the readings of the instrument taken.
- b) If test planes are specified (e.g. planes 1 and 2), the difference of the reading in the two positions of the linear displacement sensor, 180° apart, should be noted for each of these planes.

When reference square is used for measurement, reverse measuring procedure (rotate the square gauge 180° to cancel the gauge error) is recommended.

In order to eliminate the influence of the axial error motion of the spindle, which can make the measurement inaccurate, a fixture with two equal arms may be used to carry two measuring instruments, offset by 180° , and the mean of their readings taken, provided the linear displacement sensors are set to zero in the same contact point.

The test may also be verified with only one linear displacement sensor. After the first test, the instrument is moved through 180° relative to the spindle and the test repeated (see ISO/TR 5460:1985, Clause 14).

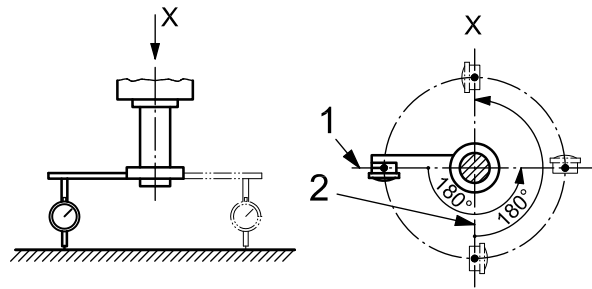

Key

- 1 plane 1
- 2 plane 2

Figure 138 — Measurement of squareness error between an axis of rotation and a plane

12.4.2 Two planes at 90° to each other

A cylindrical square is set on one of the planes (see Figure 139). The linear displacement sensor is moved along the other plane and readings taken at regular intervals. The cylindrical square is then rotated through 180° and a second set of readings is taken. An average value is then obtained from the two sets of readings.

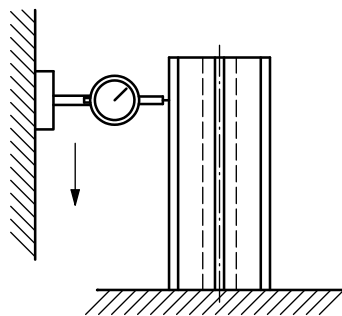

Figure 139 — Measurement of perpendicularity error between two planes

12.4.3 Two fixed axes at 90° to each other

A square with a suitable base is placed on the cylinder representing one of the two axes (see Figure 140). Parallelism between the free arm and the second axis is measured by the method described in connection with the measurement of parallelism (see 12.3.2.4).

12.4.4 A stationary axis and a plane at 90° to each other

A square with a suitable base is brought into contact with the cylinder representing the axis (see Figure 141).

Parallelism of the free arm to the plane is measured in two perpendicular directions by the method given in connection with the measurement of parallelism (see 12.3.2.2).

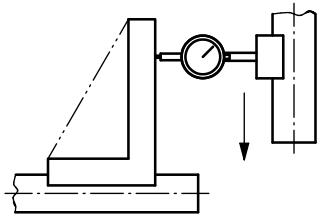

Figure 140 — Measurement of perpendicularity error between two stationary axes

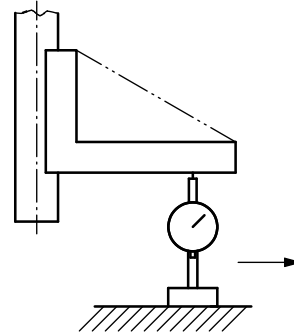

Figure 141 — Measurement of perpendicularity error between a stationary axis and a plane

12.4.5 Squareness error between an axis of linear motion and a plane

A square is placed on the plane (see Figure 142). Parallelism between the motion and the free arm shall be measured in two perpendicular directions, in accordance with 12.3.2.5.2.

12.4.6 Squareness error between an axis of linear motion and a stationary axis

A square, with a suitable base, is placed against the cylinder representing the axis (see Figure 143). The measurement of parallelism between the motion and the free arm of the square shall be made in accordance with 10.1.3.

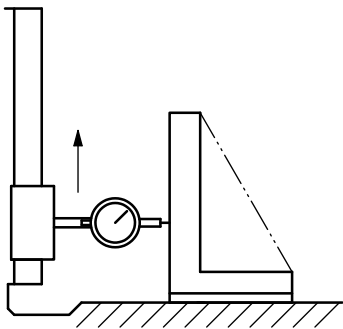

Figure 142 — Measurement of squareness error between an axis of linear motion and a plane

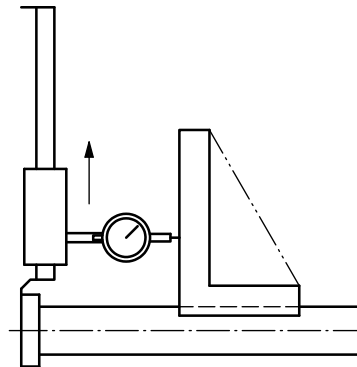

Figure 143 — Measurement of squareness error between an axis of linear motion and a stationary axis

12.4.7 Squareness between an axis of rotation and a stationary axis

A displacement transducer is attached to an arm fitted to the mandrel representing the axis of rotation and is brought into contact with two points, A and B, on the cylinder representing the other axis (see Figure 144). Change in the readings is expressed in relation to distance AB.

If the second axis is also an axis of rotation, the cylinder representing it is brought into the mean position of the run-out in the plane of measurement, according to the method described in connection with the measurement of parallelism (see 12.4.1).

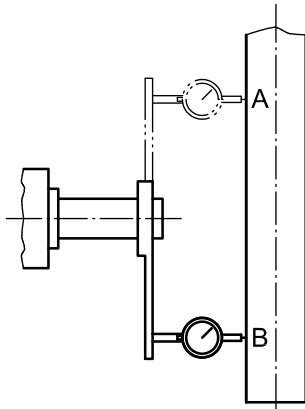

Figure 144 — Measurement of squareness error between an axis of rotation and a stationary axis

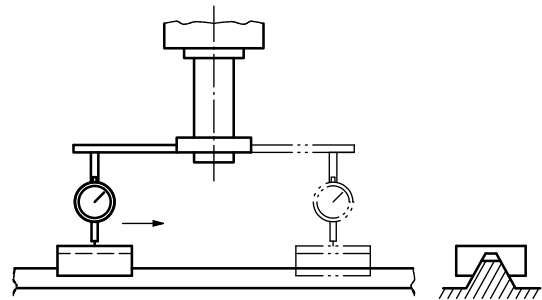

Figure 145 — Measurement of squareness error between an axis of rotation and the intersection of two planes

12.4.8 Squareness of an axis of rotation to a plane

A linear displacement sensor is attached to an arm fixed on the spindle and the operation is as given in 12.4.1.

12.4.9 Squareness of an axis of rotation to the intersection of two planes

A displacement transducer is attached to an arm held on the spindle, the stylus being against a block which rests on the two intersecting planes' surfaces. The spindle is given half a turn and the V-block moved to bring the stylus into contact with the same point on the block (see Figure 145).

12.4.10 A fixed axis at 90° to the intersection of two planes

A square with a suitable base is brought into contact with the cylinder representing the axis (see Figure 146).

Parallelism between its free arm and the intersection is measured by the method proposed in connection with the measurement of parallelism (see 12.3.2.6).

12.4.11 When the intersection of two planes is at 90° to another plane

A square and a linear displacement sensor, as appropriate, are fitted with a suitable base, allowing them to rest on the intersecting planes (see Figure 147).

Parallelism between its free arm and the third plane or the intersection may be measured by the method described in connection with the measurement of parallelism (see 12.3.2.6 or 12.3.2.8). The measurement shall be made as far as possible in two perpendicular planes.

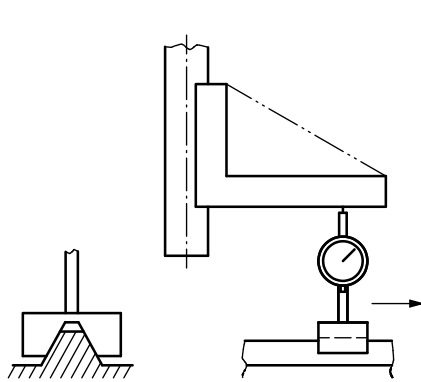

Figure 146 — Measurement of perpendicularity error between a stationary axis and the intersection of two planes

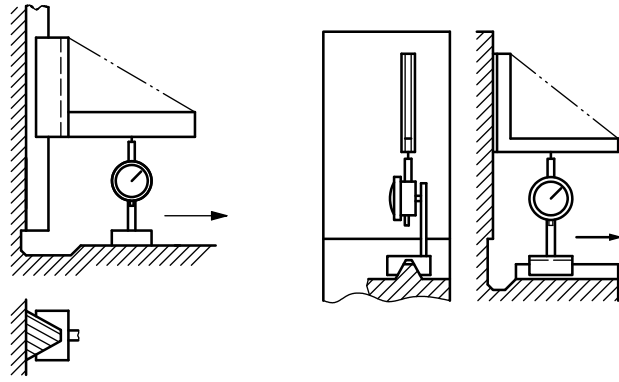

Figure 147 — Measurements of perpendicularity error between the intersection of two planes and another plane

12.4.12 When two straight lines, each formed by the intersection of two planes, are at 90° to each other

A square with a suitable base is placed on one of the intersections. The parallelism of the free arm to the second straight line of intersection is checked by the method described in connection with the measurement of parallelism (see 12.3.2.8).

If direct measurement of the planes and straight lines concerned is difficult due to the distance between them, or due to interference by machine components, the measurement may be made in relation to a reference plane, e.g. by the use of a level.

12.5 Run-out of rotational components

12.5.1 Precautions before testing

Before the test is carried out, the spindle shall be rotated sufficiently to ensure that the lubrication film does not vary during the test and that the temperature attained can be considered as the normal running temperature of the machine.

NOTE Axis of rotation error motions are, in most cases, included in the test results.

12.5.2 External surface

The stylus of a linear displacement sensor is brought into contact with the revolving surface to be measured and the readings of the instrument observed while the spindle is slowly rotated (see Figure 148).

On a conical surface, the stylus is set at right angles to the generating line and the influence of the taper on the results shall be calculated. Furthermore, the diameter of the circle being checked varies if there is any axial movement in the spindle during its rotation. This causes the run-out to appear greater than it actually is. Therefore, a conical surface shall only be used for measuring the run-out if the taper is not steep. The axial error motion (3.5.5) of the spindle is in any case measured previously and its possible effect on the measurement is computed according to the angle of taper.

The measured results can be affected by the lateral thrust on the stylus of the linear displacement sensor. To avoid errors, the stylus shall be strictly aligned with the axis of the revolving surface.

12.5.3 Internal surface

If the linear displacement sensor cannot be used directly on a cylindrical or tapered bore, a test mandrel is mounted in the bore. The projecting cylindrical part of this mandrel shall be used for the test, in accordance with 12.5.2. However, if the test is made at one section only of the mandrel, the position of only one circle of measurement in relation to the axis would be determined. As the axis of the mandrel may cross the axis of rotation in the measurement plane, measurement should be done at two sections A and B, which are a specified distance apart (see Figure 149).

For instance, one measurement should be made close against the housing of the mandrel and another at a specified distance from it. Due to potential nesting problems when inserting the mandrel into the bore, particularly with tapered bores, these operations shall be repeated at least four times, the mandrel being turned through 90° in relation to the spindle. The average of the readings shall be taken.

In each case, the run-out shall be measured in a vertical axial plane and then in a horizontal axial plane (positions C₁ and C₂ in Figure 149).

The above-mentioned methods (in this subclause) require the following comments.

Steps should be taken to minimize the effect of the tangential drag upon the stylus of the measuring instrument.

When using a test mandrel, the exact shape of the bore is not revealed.

A check of the run-out of the spindle by machining and testing a cylindrical workpiece takes into account only defects in the bearings of the spindle.

This practical turning test gives no information on the exact shape of the cylindrical or conical bore, or of the actual position of the bore in relation to the axis of rotation.

Spindles which are automatically centred during rotation (e.g. by hydraulic pressure; hydrodynamic spindle) can be tested only when running at normal speed. In such a case, non-contact measuring instruments shall be used, e.g. a capacitive pickup, an inductive pickup or any other suitable instrument.

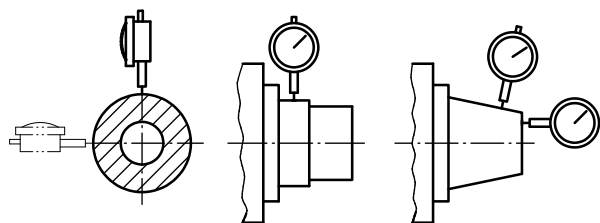

Figure 148 — Measurement of external run-out

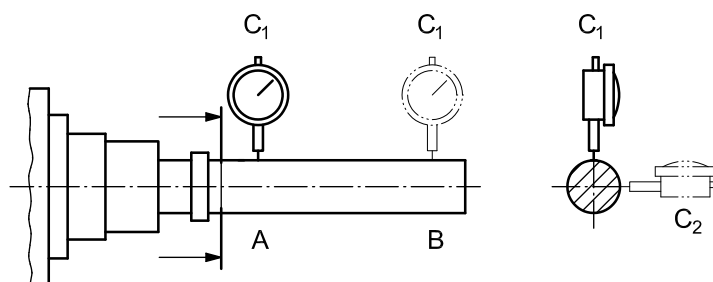

Figure 149 — Measurement of internal run-out

Annex A (informative)

Machine tool coordinate system and position and orientation errors

A.1 General

Although the nomenclature for the machine axes of motion is specified in ISO 841, mere labelling of the axes is not adequate for the purposes of the characterization of machine geometric errors and the compensation for their effects using machine tool controllers. This annex provides a systematic way to define a machine tool coordinate system, in which the geometric relationships among the axes of motion and associated errors are clearly defined.

By describing the positions and orientations of the axes of motion in a coordinate system, the alignment errors among these axes, necessary for geometric accuracy evaluation and/or software-based error compensation, can be identified for any machine structural configuration.

To eliminate redundant alignment error measurements among the axes of motion, the origin and orientation of the machine tool coordinate system is chosen to orientate the primary axis of motion (defining two orientations) and the secondary axis of motion (defining the third orientation).

Three examples are given to clarify the descriptions: one of a three-axis machine tool (see A.5), one of a five-axis machine tool (see A.6) and one for a multi-tasking turning centre (see A.7). It is shown that there are five orientation errors necessary to fully characterize a three-axis machine tool (the three squareness errors of the axes, plus the two orientations of the spindle to the machine tool coordinate system), and 12 position and orientation errors for a five-axis machine tool and for a multi-tasking turning centre.

A.2 Reference straight line of a linear axis of motion

A reference straight line of a linear axis of motion is represented by a straight line with two orientations (angles) in a 3-D coordinate system. In addition, for a numerically controlled linear positioning axis, the error of the zero position of the axis (e.g. E_{Z0Z}) is also included in the total number of error terms representing the axis as shown in Figure A.1.

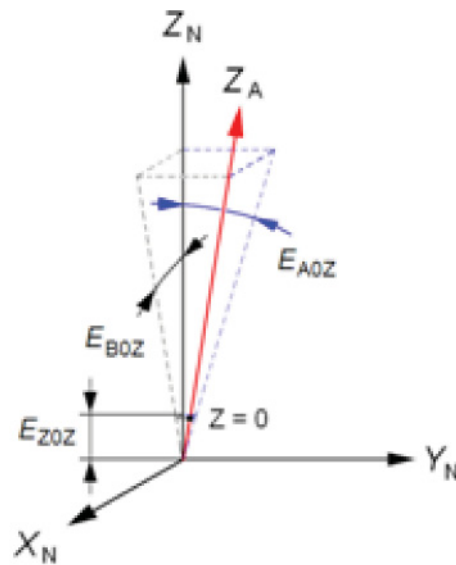

Key

- X_N nominal X-axis
- Y_N nominal Y-axis
- Z_N nominal Z-axis
- Z_A actual reference straight line of the moving component along Z-direction
- E_{Z0Z} zero position error of Z
- E_{A0Z} squareness error of Z to Y
- E_{B0Z} squareness error of Z to X

NOTE In general, errors of the zero positions of linear axes (e.g. E_{Z0Z}) can be set to zero (0) when checking geometric accuracy of a machine tool.

Figure A.1 — Position and orientation errors of a linear axis, Z

Due to the error motions of horizontal and vertical straightness, roll, pitch and yaw, the trajectory of the linear moving component of the machine is not a straight line, but a trajectory in space like actual trajectory “a” shown in Figure A.2. The shape of this trajectory depends on the location of the trajectory in the work envelope as well as on the magnitudes and directions of the error motions, e.g. it can change to actual trajectory “b” shown in Figure A.2. If all error motions of the linear axis are taken into account, actual trajectory “b” can be calculated based on actual trajectory “a” in Figure A.2.

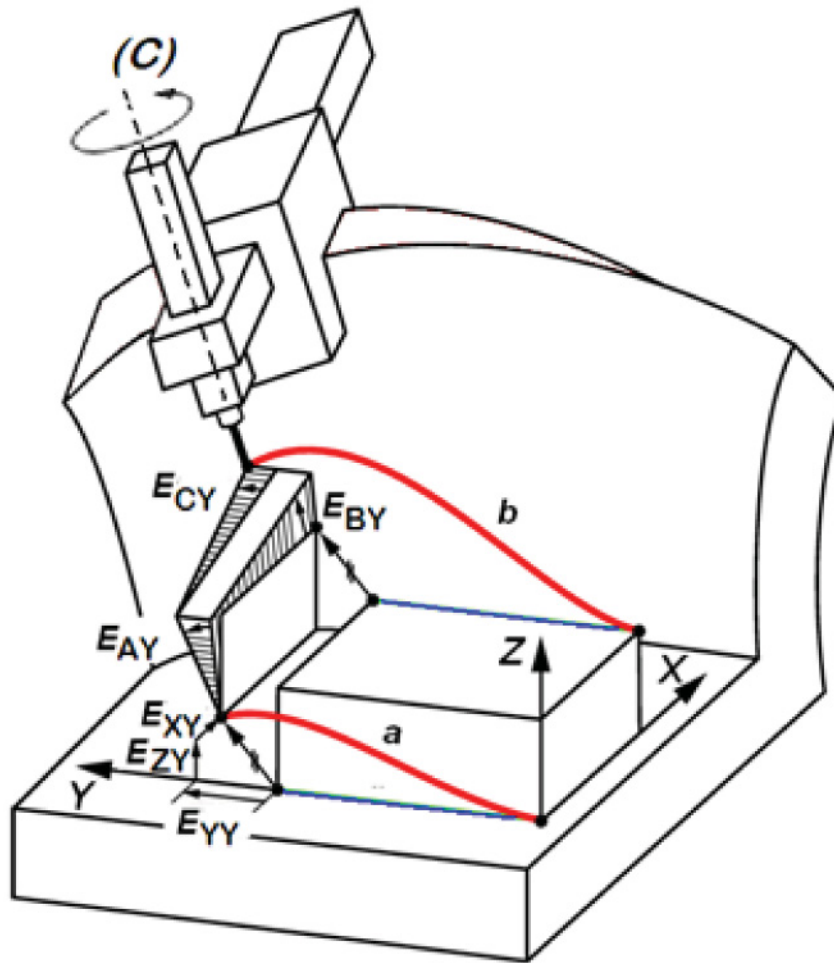

- Key**
- X (nominal) X-axis
 - Y (nominal) Y-axis
 - Z (nominal) Z-axis
 - a, b actual trajectories of (nominal) Y-axis linear motion
 - E_{AY} angular error of Y in A-axis direction (pitch)
 - E_{BY} angular error of Y in B-axis direction (roll)
 - E_{CY} angular error of Y in C-axis direction (yaw)
 - E_{XY} straightness deviation of Y in X-axis direction
 - E_{YY} positioning error of Y-axis
 - E_{ZY} straightness deviation of Y in Z-axis direction

Figure A.2 — Machine tool with error motions along the linear Y-axis

The user should decide which trajectory is used as the reference trajectory. This reference trajectory is taken to define the reference straight line of the linear axis of motion, e.g. the end-point reference straight line. This reference straight line in a 3-D machine coordinate system defines two orientation parameters (angles). In the case of Figure A.2, the reference straight line of Y defines the squareness error of Y to X, E_{COY} , and the squareness error of Y to Z, E_{AOY} .

A.3 Reference straight line of an axis of rotation

In the case of a rotating component with its associated axial, radial and tilt error motions, the reference straight line representing the axis of rotation is the axis average line of this component.

An axis average line of an axis of rotation of a rotating component is represented by a straight line, which has four parameters: two position coordinates (along the coordinate axes orthogonal to the nominal direction of the axis of rotation) and two orientations (angles) in a 3-D coordinate system. The two position errors and the two orientation errors of an axis of rotation, nominally parallel to the reference Z-axis, are depicted in Figure 13 (see 3.5.8). Similarly, for a numerically controlled rotary positioning axis, the error of the zero angular position of the axis (e.g. E_{C0C}) is also included in the total number of error terms.

In general, errors of zero angular positions of rotary axes (e.g. E_{C0C}) can be set to zero (0) when checking geometric accuracy of machines.

A.4 Machine tool coordinate system

As prescribed by ISO 841, the machine coordinate system is a right-hand rectangular system. The position and orientation of the machine tool coordinate system is typically defined by the axes of motion of its moving components.

The origin and reference lines for the machine tool coordinate system can be chosen arbitrarily. However, it is often more practical to position and orientate the machine tool coordinate system utilizing the reference lines of the axes of motion of the machine tool such that six of the position and orientation parameters of the machine tool are set to zero. This is done by first choosing a primary axis of motion to have its reference straight line to be aligned with one axis of the machine tool coordinate system, thus defining two orientation parameters and the orthogonal plane in which the two other axes of the machine coordinate system lie. Then, a secondary axis of motion is chosen such that its reference straight line defines the third orientation parameter, resulting from the reference straight line's projection on the previously defined plane. Finally, an origin of the machine tool coordinate system is chosen defining three position parameters. The selection of primary axis, secondary axis and origin for the machine tool coordinate system depends on the machine tool design, possibilities for mechanical correction, and possibilities for mechanical and/or software compensation.

The three examples in A.5, A.6 and A.7 (one three-axis machine tool, one five-axis machine tool, one multi-purpose turning centre) show how the choice of the machine tool coordinate system affects which position and orientation parameters require measurement.

For software-based error compensation, sometimes an optimized machine tool coordinate system is calculated based on user-defined requirements. A suitable approach may be to orientate the machine coordinate system as close as possible to a physical axis of the machine (e.g. the main spindle axis) and position it at a point of interest, e.g. the centre point of the working volume.

A.5 Machine tool coordinate system for a three-axis machine tool

For the machine tool represented in Figure A.2, there are 13 position and orientation error parameters, shown in Table A.1:

Table A.1 — Position and orientation error parameters for a three-axis machine tool

Y-axis	X-axis	Z-axis	(C)-spindle
—	E_{X0X}	—	$E_{X0(C)}$
E_{Y0Y}	—	—	$E_{Y0(C)}$
—	—	E_{Z0Z}	—
E_{A0Y}	—	E_{A0Z}	$E_{A0(C)}$
—	E_{B0X}	E_{B0Z}	$E_{B0(C)}$
E_{C0Y}	E_{C0X}	—	—

Table A.1 indicates the position and orientation parameters if any arbitrary coordinate system is selected as the machine tool coordinate system. Since, in principle, all zero positions of linear axes can be set to zero for checking the geometric accuracy of the machine tool, Table A.1 can be simplified as shown in Table A.2.

Table A.2 — Simplified list of error parameters for a three-axis machine tool

Y-axis	X-axis	Z-axis	(C)-spindle
—	(0)	—	$E_{X0(C)}$
(0)	—	—	$E_{Y0(C)}$
—	—	(0)	—
E_{A0Y}	—	E_{A0Z}	$E_{A0(C)}$
—	E_{B0X}	E_{B0Z}	$E_{B0(C)}$
E_{C0Y}	E_{C0X}	—	—

If the machine tool linear axes of motion are used for defining position and orientation of the machine tool coordinate system, five position and orientation errors in Table A.2 can be set to zero (or to any nominal arbitrary value).

Consider the following example:

- if the Y-axis is chosen as the primary axis, the reference straight line of the Y-axis coincides with the Y-axis of the machine tool coordinate system, meaning that E_{A0Y} and E_{C0Y} can be set to zero;
- if the X-axis is chosen as the secondary axis, the reference straight line of the X-axis defines the orientation of the X-axis of the machine tool coordinate system, meaning that E_{B0X} can be set to zero;
- if the position of (C)-spindle (intersection of spindle axis average line with the XY plane) defines the origin of the machine tool coordinate system, the two parameters, E_{X0C} and E_{Y0C} , can be set to zero.

Therefore, just the following five orientation errors of the machine tool of Figure A.2 would remain to be measured (see Table A.3).

Table A.3 — Minimum number of error parameters to fully characterize a three-axis machine tool

Y-axis	X-axis	Z-axis	(C)-spindle
—	(0)	—	0
(0)	—	—	0
—	—	(0)	—
0	—	E_{A0Z}	$E_{A0(C)}$
—	0	E_{B0Z}	$E_{B0(C)}$
0	E_{C0X}	—	—

The Z-position of the tool's functional point can be used as the Z-reference for the origin of the machine tool coordinate system.

NOTE This procedure corresponds to establishing a workpiece coordinate system, where reference "A" defines the primary axis, reference "B" the secondary axis and reference "C" the origin of the workpiece coordinate system.

The following is the summary of the resulting geometric error parameter measurements, related to orientation errors, which are required for such a machine tool:

- E_{C0X} squareness error of X to Y;
- E_{A0Z} squareness error of Z to Y;
- E_{B0Z} squareness error of Z to X;
- $E_{A0(C)}$ squareness error of (C) to Y;
- $E_{B0(C)}$ squareness error of (C) to X.

Once the machine tool coordinate system is defined, the positions and orientations of functional surfaces (orientation of machine table, orientation of reference slots, orientation and position of spindle nose, etc.) are determined with respect to this coordinate system.

A.6 Machine tool coordinate system for a five-axis machine tool

For the five-axis machine tool shown in Figure A.3, there are 23 position and orientation error parameters as shown in Table A.4.

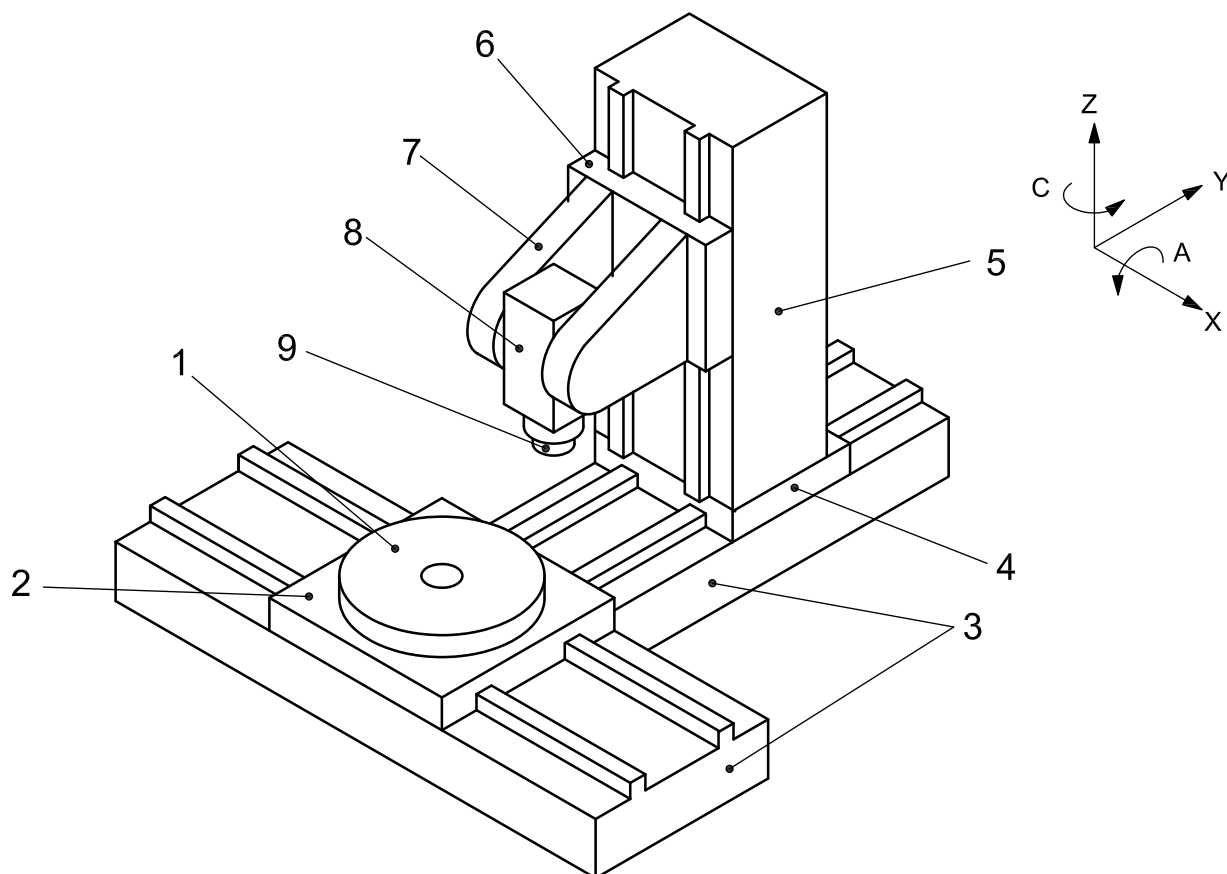

Key

- 1 rotary table (C'-axis)
- 2 tabel saddle (X'-axis)
- 3 bed
- 4 column saddle (Y-axis)
- 5 column
- 6 yoke saddle (Z-axis)
- 7 yoke
- 8 swivel spindle head (A-axis)
- 9 spindle (C1-axis)

Figure A.3 — A five-axis machine tool configuration

Table A.4 — Position and orientation error parameters for a five-axis machine tool

C-axis	X-axis	Y-axis	Z-axis	A-axis	(C1)-spindle
E_{X0C}	E_{X0X}	—	—	—	$E_{X0(C1)}$
E_{Y0C}	—	E_{Y0Y}	—	E_{Y0A}	$E_{Y0(C1)}$
—	—	—	E_{Z0Z}	E_{Z0A}	—
E_{A0C}	—	E_{A0Y}	E_{A0Z}	E_{A0A}	$E_{A0(C1)}$
E_{B0C}	E_{B0X}	—	E_{B0Z}	E_{B0A}	$E_{B0(C1)}$
E_{C0C}	E_{C0X}	E_{C0Y}	—	E_{C0A}	—

Since, in principle, all zero positions of linear and rotary axes can be set to zero when checking the geometric accuracy of the machine tool, Table A.4 can be simplified as shown in Table A.5.

Table A.5 — Simplified list of error parameters for a five-axis machine tool

C-axis	X-axis	Y-axis	Z-axis	A-axis	(C1)-spindle
E_{X0C}	(0)	—	—	—	$E_{X0(C1)}$
E_{Y0C}	—	(0)	—	E_{Y0A}	$E_{Y0(C1)}$
—	—	—	(0)	E_{Z0A}	—
E_{A0C}	—	E_{A0Y}	E_{A0Z}	(0)	$E_{A0(C1)}$
E_{B0C}	E_{B0X}	—	E_{B0Z}	E_{B0A}	$E_{B0(C1)}$
(0)	E_{C0X}	E_{C0Y}	—	E_{C0A}	—

If the machine tool coordinate system is chosen in the following way:

- the X-axis is chosen as the primary axis;
- the Y-axis is chosen as the secondary axis;
- the origin is chosen to be along the C-axis average line at the height (Z coordinate), where the A-axis average line intersects with the ZY plane when all axes are commanded to zero.

Then, only the 12 parameters shown in Table A.6 would remain.

Table A.6 — Minimum number of error parameters to fully characterize a five-axis machine tool

C-axis	X-axis	Y-axis	Z-axis	A-axis	(C1)-spindle
0	(0)	—	—	—	$E_{X0(C1)}$
0	—	(0)	—	E_{Y0A}	$E_{Y0(C1)}$
—	—	—	(0)	0	—
E_{A0C}	—	0	E_{A0Z}	(0)	$E_{A0(C1)}$
E_{B0C}	0	—	E_{B0Z}	E_{B0A}	$E_{B0(C1)}$
(0)	0	E_{C0Y}	—	E_{C0A}	—

Therefore, the following is the summary of the resulting geometric error parameter measurements, related to position and orientation errors, which are required for such a machine tool:

- E_{A0C} squareness error of C to Y;
- E_{B0C} squareness error of C to X;
- E_{C0Y} squareness error of Y to X;
- E_{A0Z} squareness error of Z to Y;
- E_{B0Z} squareness error of Z to X;

- E_{Y0A} Y offset error from A to C;
- E_{B0A} parallelism error of A to X in the reference ZX plane;
- E_{C0A} parallelism error of A to X in the reference XY plane;
- $E_{X0(C1)}$ X offset error from (C1) to C at the reference XY plane;
- $E_{Y0(C1)}$ Y offset error from (C1) to C at the reference XY plane;
- $E_{A0(C1)}$ squareness error of (C1) to Y;
- $E_{B0(C1)}$ squareness error of (C1) to X.

In order to fully evaluate the performance of the machine, the distance along the (C1) (spindle) axis from the A-axis to the functional point of the tool should also be measured. This distance should be considered when the kinematic tests, such as simultaneous three-axis motion tests, are conducted using a spherical ball and sensors (R-test) or a ball bar instrument in the machine tool with swivel spindle head. However, this is not considered a machine position parameter, but rather a position parameter of the tool. Thus, it is not included in this annex.

Choosing the origin and primary and secondary axes for the machine tool coordinate system differently results in a different set of geometric accuracy measurements. Regardless of how the machine tool coordinate system is chosen, the number of parameters to be measured remains 12, consisting of three positions and nine orientations. Measuring fewer errors than this gives an incomplete description of the machine position and orientation errors. Measuring more errors than this creates redundant error measurements. That is, one or more of the measurements can be deduced by a combination of the remaining measurements. For example, in this case, it is unnecessary to measure the parallelism of C to (C1), as it can be calculated from E_{A0C} , $E_{A0(C1)}$, E_{B0C} and $E_{B0(C1)}$.

NOTE It is sometimes convenient to describe error motions of one axis relative to the axis on which it is mounted. The notation of error parameters given in 3.6.7 can also describe error parameters in a relative sense. For example, in the machine configuration depicted in Figure A.3, the squareness of the A-axis average line of rotation to the Z-axis is represented by $E_{B(0Z)A}$ in the “relative” notation, whereas it is E_{B0A} - E_{B0Z} in the “absolute” notation above. The derivation procedure of the minimum set of error parameters in the “relative” notation is studied, e.g. in Inasaki^[12].

A.7 Machine tool coordinate system for a multi-tasking turning centre

For the multi-tasking turning centre shown in Figure A.4, there are 23 position and orientation error parameters as shown in Table A.7.

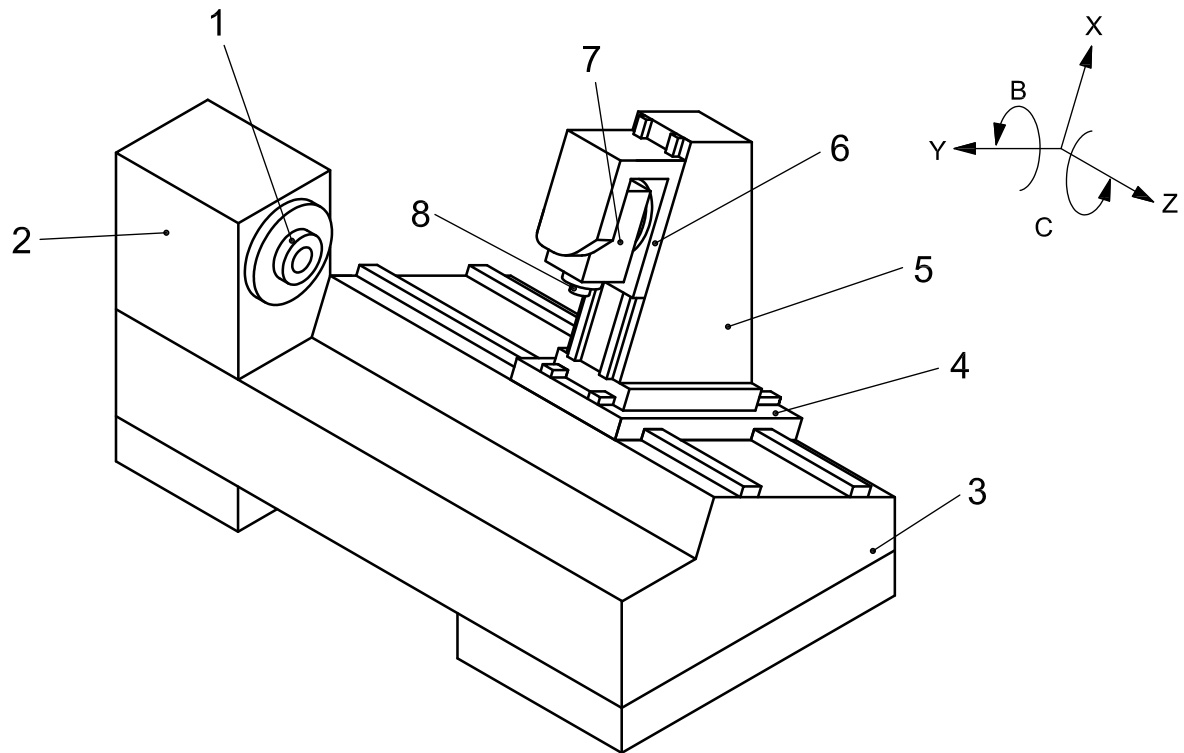

Key

- 1 work spindle (C'-axis)
- 2 work spindle head
- 3 bed
- 4 column saddle (Z-axis)
- 5 column (Y-axis)
- 6 cross slide (X-axis)
- 7 swivel spindle head (B-axis)
- 8 tool spindle (A-axis)

Figure A.4 — A multi-tasking turning centre configuration

Table A.7 — Position and orientation error parameters for a multi-tasking turning centre

C-axis	Z-axis	Y-axis	X-axis	B-axis	(A)-spindle
E_{X0C}	—	—	E_{X0X}	E_{X0B}	—
E_{Y0C}	—	E_{Y0Y}	—	—	$E_{Y0(A)}$
—	E_{Z0Z}	—	—	E_{Z0B}	$E_{Z0(A)}$
E_{A0C}	E_{A0Z}	E_{A0Y}	—	E_{A0B}	—
E_{B0C}	E_{B0Z}	—	E_{B0X}	E_{B0B}	$E_{B0(A)}$
E_{C0C}	—	E_{C0Y}	E_{C0X}	E_{C0B}	$E_{C0(A)}$

Since, in principle, all zero positions of linear and rotary axes can be set to zero when checking the geometric accuracy of the machine tool, Table A.7 can be simplified as shown in Table A.8.

Table A.8 — Simplified list of error parameters for a multi-tasking turning centre

C-axis	Z-axis	Y-axis	X-axis	B-axis	(A)-spindle
E_{X0C}	—	—	(0)	E_{X0B}	—
E_{Y0C}	—	(0)	—	—	$E_{Y0(A)}$
—	(0)	—	—	E_{Z0B}	$E_{Z0(A)}$
E_{A0C}	E_{A0Z}	E_{A0Y}	—	E_{A0B}	—
E_{B0C}	E_{B0Z}	—	E_{B0X}	(0)	$E_{B0(A)}$
(0)	—	E_{C0Y}	E_{C0X}	E_{C0B}	$E_{C0(A)}$

If the machine tool coordinate system is chosen in the following way:

- The Z-axis is chosen as the primary axis.
- The X-axis is chosen as the secondary axis.
- The origin is chosen to be along the B-axis average line at the Y coordinate, where the (A)-axis average line intersects with the YZ plane when all axes are commanded to zero.

Then, only the 12 parameters shown in Table A.9 would remain.

Table A.9 — Minimum number of error parameters to fully characterize a multi-tasking turning centre

C-axis	Z-axis	Y-axis	X-axis	B-axis	(A)-spindle
E_{X0C}	—	—	(0)	0	—
E_{Y0C}	—	(0)	—	—	0
—	(0)	—	—	0	$E_{Z0(A)}$
E_{A0C}	0	E_{A0Y}	—	E_{A0B}	—
E_{B0C}	0	—	E_{B0X}	(0)	$E_{B0(A)}$
(0)	—	E_{C0Y}	0	E_{C0B}	$E_{C0(A)}$

Therefore, the following is the summary of the resulting geometric error parameter measurements, related to position and orientation errors, which are required for such a multi-tasking turning centre:

- E_{X0C} X offset error from C to B in reference XY plane;
- E_{Y0C} Y offset error from C to (A) in reference XY plane;
- E_{A0C} parallelism error of C to Z in YZ plane;
- E_{B0C} parallelism error of C to Z in ZX plane;
- E_{B0X} squareness error of X to Z;
- E_{A0Y} squareness error of Y to Z;
- E_{C0Y} squareness error of Y to X;

- E_{A0B} squareness error of B to Z;
- E_{C0B} squareness error of B to X;
- $E_{Z0(A)}$ Z offset error from (A) to B in reference YZ plane;
- $E_{B0(A)}$ squareness error of (A) to Z;
- $E_{C0(A)}$ parallelism error of (A) to X in reference XY plane.

In order to fully evaluate the performance of the machine, the distance along the (A) (spindle) axis from the B-axis to the functional point of the tool should also be measured. This distance should be considered when the kinematic tests, such as simultaneous three-axis motion tests, are conducted using a spherical ball and sensors (R-test) or a ball bar instrument in the machine tool with swivel spindle head. However, this is not considered a machine position parameter, but rather a position parameter of the tool. Thus, it is not included in this annex.

Choosing the origin and primary and secondary axes for the machine tool coordinate system differently results in a different set of geometric accuracy measurements. Regardless of how the machine tool coordinate system is chosen, the number of parameters to be measured remains 12, consisting of three positions and nine orientations. This is shown in the following example, where the origin of the machine tool coordinate system is chosen differently.

If the machine tool coordinate system is chosen in the following, alternative way:

- the Z-axis is chosen as the primary axis;
- the X-axis is chosen as the secondary axis.
- The origin is chosen to be along the C-axis average line at the Z coordinate, where the B-axis average line intersects with the ZX plane when all axes are commanded to zero.

Then, the following 12 parameters shown in Table A.10 would remain, again starting with Table A.8:

Table A.10 — Minimum number of error parameters to fully characterize a multi-tasking turning centre for another origin of the machine tool coordinate system

C-axis	Z-axis	Y-axis	X-axis	B-axis	(A)-spindle
0	—	—	(0)	E_{X0B}	—
0	—	(0)	—	—	$E_{Y0(A)}$
—	(0)	—	—	0	$E_{Z0(A)}$
E_{A0C}	0	E_{A0Y}	—	E_{A0B}	—
E_{B0C}	0	—	E_{B0X}	(0)	$E_{B0(A)}$
(0)	—	E_{C0Y}	0	E_{C0B}	$E_{C0(A)}$

Now, the following is the summary of the resulting geometric error parameter measurements, related to position and orientation errors, which are required for such a multi-tasking turning centre with the alternatively chosen origin of the coordinate system:

- E_{A0C} parallelism error of C to Z in YZ plane;
- E_{B0C} parallelism error of C to Z in ZX plane;

- E_{B0X} squareness error of X to Z;
- E_{A0Y} squareness error of Y to Z;
- E_{C0Y} squareness error of Y to X;
- E_{X0B} X offset error from B to C in reference XY plane;
- E_{A0B} squareness error of B to Z;
- E_{C0B} squareness error of B to X;
- $E_{Y0(A)}$ Y offset error from (A) to C in reference YZ plane;
- $E_{Z0(A)}$ Z offset error from (A) to B in reference YZ plane;
- $E_{B0(A)}$ squareness error of (A) to Z;
- $E_{C0(A)}$ parallelism error of (A) to X in reference XY plane.

Annex B (informative)

Test piece measurement

B.1 Machining tests

B.1.1 Testing

Machining tests comprise the finishing operations for which the machine has been designed.

If machining tests are carried out, standard test pieces should be used. Standard test pieces are defined in machine-specific International Standards.

The number of workpieces or, as the case may be, the number of cuts to be made on a given workpiece, should be such as to make it possible to determine the nominal accuracy. If necessary, wear on the cutting tool used should be taken into account.

The tooling and the fixture conditions should be such as to make it possible to determine the normal accuracy and these conditions should be reported.

B.1.2 Checking of test pieces in machining tests

Checking of workpieces in machining tests should be carried out by measuring instruments selected for the kind of measurement to be made and the required measurement uncertainty.

NOTE Measuring methods are described in B.2.

Specification and interpretation of test pieces tolerances shall conform to ISO 1101.

B.1.3 Machining tests and quasi-static behaviour

The following should apply in order for the results of machining tests to be related to the geometric accuracy of a machine tool:

- a) the machine tool shall move slowly and behave in a quasi-static manner, i.e. with no dynamic influences and servo [control] limitations. However, this provision is not applicable to some machine tool-specific test pieces execution (e.g. five-axes contouring test pieces) where the aim is to test machine performances at specified tool path feedrate;
- b) the machine tool should not be influenced by any significant machining forces, which is the case for most finishing cuts;
- c) the machine tool should not be influenced by any thermal load, i.e. the machine tool should be in a thermally stable condition;
- d) the tool and the cutting parameters, i.e. feed, speed, tool geometry, etc., should be suitable for the material machined and correspond to the nominal values;
- e) the material machined should be uniform, i.e. its parameters like hardness and strength do not change over the machined surface;
- f) the tool used should not be worn and should not wear significantly during the machining of the test pieces.

B.2 Test piece measurement

B.2.1 General

Measurement procedures, except for circularity of cylindrical parts and consistency of machined diameters, should be according to ISO/TR 5460. Measurements by CMM are also applicable.

The test piece should have been machined according to the procedures described in B.1.

Recommended minimum numbers of measurement points on the test piece are: 10 for line, 15 for circle, 15 for plane, 25 for cylinder and 30 for cone.

The relationship between the reference line/plane of the measurement and machining should be recorded so as to help identifying possible machine error sources.

B.2.2 Measurement uncertainty

See Clause 5. Uncertainties associated with the measurement of the geometric accuracy of the machined test piece should not be attributed to the test piece itself or to the machine tool.

Uncertainty of measurement of available measurement systems should be taken into account when specifying test piece tolerances and when evaluating conformance with specified tolerances in order to avoid situations where neither conformance nor non-conformance to specifications can be demonstrated (see 4.1.1).

B.2.3 Consistency of machined diameters

B.2.3.1 General

In addition to tolerances of size, form, orientation location and run-out specified by relevant International Standards, some machine tool-specific standards (e.g. turning machines and turning centres International Standards) specify consistency of machined diameters.

Diameters are said to be consistent when the range of diameters, machined at intervals along the test piece and measured in a single axial plane, conforms to the specified tolerance.

This subclause describes two methods to test conformance to such specification.

B.2.3.2 Micrometer or similar two-point measuring instrument

Readings are taken at each band in one plane only.

Measurements can be taken while the test piece is still on the machine tool (see Figure B.1).

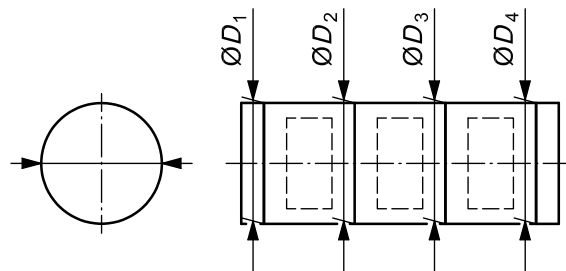

Figure B.1 — Measurements with two-point measuring instrument

Annex C (informative)

Cross-reference

ISO 230-1:1996		ISO 230-1:2012	
(Sub) clause	Title	(Sub) clause	Title
1	Scope	1	Scope
2	General considerations		
2.1	Definition relating to geometric tests	3.1	General
2.2	Test methods and use of measuring instruments	6.3	Test setup and instrumentation
2.3	Tolerances	4	Tolerances
2.3.1	Tolerances on measurements when testing machine tools	4.1	General
2.311	Unit of measurement and measuring range		
2.312	Rules concerning tolerances	4.1.1	Rules concerning tolerance and conformance zone
2.32	Subdivisions of tolerances		
2.321	Tolerances applicable to test pieces and to individual components of machine tools	4.2	Tolerances applicable to machine tool functional surfaces, machine tool components and test pieces
2.321.1	Tolerances of dimension		
2.321.2	Tolerances of form		
2.321.3	Tolerances of position		
2.321.4	Influence of errors of form in determining positional errors	5	Uncertainty of measurements, test methods and measuring instruments
2.321.5	Local tolerances	4.1.3	Local tolerances
2.322	Tolerance applicable to the displacement of a component of a machine tool	4.1	General
2.322.1	Tolerances of positioning		
2.322.11	Tolerances of repeatability		
2.322.2	Tolerances of the form of trajectory		
2.322.3	Tolerances of relative position of straight-line motion		
2.322.4	Local tolerance of displacement of a component	4.1.3	Local tolerances
2.323	Overall or inclusive tolerances	4.1.4	Overall or inclusive tolerances
2.324	Symbols and positions of tolerances for relative angular positions of axes, slideways, etc.	4.3	Additional limiting conditions associated with tolerances
2.325	Conventional definition of the axes and the movements	3.2	Definitions for machine coordinate system and motion nomenclature
3	Preliminary operations	6	Preliminary operations

ISO 230-1:1996		ISO 230-1:2012	
(Sub) clause	Title	(Sub) clause	Title
3.1	Installation of the machine before test	6.1	Installation of the machine before tests
3.11	Levelling	6.1.2	Levelling
3.2	Conditions of the machine before test	6.2	Conditions of the machine before tests
3.21	Dismantling of certain components	6.2.1	Disassembling of certain components
3.22	Temperature conditions of certain components before test	6.2.2	Temperature conditions of certain components before tests
3.23	Functioning and loading	6.2.4	Operating conditions
4	Machining test	B.1	Machining tests
4.1	Testing	B.1.1	Testing
4.2	Checking of workpieces in machining tests	B.1.2	Checking of test pieces in machining tests
5	Geometric tests	8	Geometric accuracy tests of axes of linear motion
5.1	General	8.1	General
5.2	Straightness	3.4.11	Straightness
5.21	Straightness of a line in a plane or in space	3.9.2	Straightness error of a functional line in a plane
5.211	Definition		
5.211.1	Straightness of a line in a plane		
5.211.2	Straightness of a line in a space		
5.212	Methods of measurement of straightness		
5.212.1	Methods based on the measurement of length	12.1.2	Methods based on measurement of distance
5.212.11	Straightedge method	12.1.2.2	Straightedge method
5.212.111	Measurement in vertical plane		
5.212.112	Measurement in a horizontal plane		
5.212.12	Taut-wire and microscope method	12.1.2.3	Taut-wire and microscope method
5.212.13	Alignment telescope method	12.1.2.4	Alignment telescope method
5.212.14	Alignment laser technique		
5.212.15	Laser interferometry technique		
5.212.2	Methods based on the measurement of angle	12.1.3	Methods based on the measurement of angles
5.212.21	Precision level method	12.1.3.2	Precision level method
5.212.22	Autocollimation method	12.1.3.3	Autocollimation method
5.212.23	Method by laser interferometer (angle measurement)	12.1.3.4	Method by laser angle interferometer
5.213	Tolerance	4	Tolerances
5.213.1	Definition		
5.213.2	Determination of tolerance		
5.22	Straightness of components	12.1	Straightness error of machine functional surfaces
5.221	Definition	3.9.2	Straightness error of a functional line in a plane

ISO 230-1:1996		ISO 230-1:2012	
(Sub) clause	Title	(Sub) clause	Title
5.222.1	Reference grooves or reference surface of tables	12.1.4	Straightness error of reference grooves or reference surface of tables
5.222.2	Slideways	12.1.5	Straightness error of slideways
5.222.21	Vee surface	12.1.6	Straightness error of V-surfaces
5.222.22	Cylindrical surfaces	12.1.7	Straightness error of cylindrical surfaces
5.222.23	Single vertical surface	12.1.8	Straightness error of single vertical surfaces
5.222.24	Slant-bed configuration	12.1.9	Straightness error of surfaces on slant-bed configuration
5.222.3	Tolerances	4	Tolerances
5.23	Straight-line motion		
5.231	Definitions	3.4.3	Error motions of a linear axis
5.231.1	Positional deviations	3.4.5	Linear positioning error motion
5.231.2	Linear deviations	3.4.4	Linear error motions of a linear axis
5.231.3	Angular deviations	3.4.16	Angular error motions of a linear axis
5.232	Methods of measurement		
5.232.1	Methods of measurement of linear deviations	8.3	Linear positioning error motion tests
5.232.11	Method with a straightedge and a dial gauge	8.2.2.1	Straightedge and a linear displacement sensor
5.232.12	Method with microscope and taut-wire	8.2.2.2	Microscope and taut wire
5.232.13	Method using an alignment telescope	8.2.2.3	Alignment telescope
5.232.14	Method using a laser	8.2.2.5	Laser straightness interferometer
5.232.15	Method using angle measurement		
5.232.2	Methods of measurement of angular deviation	8.4	Angular error motions tests
5.232.21	Method using a precision level	8.4.2.1	Precision level
5.232.22	Method using an autocollimator	8.4.2.2	Auto collimator
5.232.23	Method using a laser	8.4.2.3	Laser angle interferometer
5.233	Tolerances	4	Tolerances
5.233.1	Tolerance for the linear deviation of straight-line motion		
5.233.2	Tolerance for the angular deviation of straight-line motion		
5.3	Flatness		
5.31	Definition	3.8.5	Flatness
		3.9.8	Flatness error of a functional surface
5.32	Methods of measurement		
5.321	Measurement of flatness by means of a surface plate	12.2.1	Measurement of flatness error by means of a surface plate
5.321.1	Measurement by means of a surface plate and a dial gauge	12.2.2	Measurement by means of a surface plate and a linear displacement sensor
5.322	Measurement of flatness by means of straightedge(s)	12.2.3	Measurement by means of straightedge(s)

ISO 230-1:1996		ISO 230-1:2012	
(Sub) clause	Title	(Sub) clause	Title
5.322.1	Measurement by means of a family of straight lines by displacement of a straightedge	12.2.3.1	Measurement by means of a family of straight lines by displacement of a straightedge
5.322.2	Measurement by means of straightedges, a precision level and a dial gauge	12.2.3.2	Measurement by means of straightedges, a precision level and a linear displacement sensor
5.323	Measurement of flatness by means of a precision level	12.2.4	Measurement of flatness error by means of a precision level
5.323.1	Measurement of a rectangular surface	12.2.4.2	Measurement of a rectangular surface
5.323.2	Measurement of plane surfaces with circular contours	12.2.4.3	Measurement of plane surfaces with circular contours
5.324	Measurement of flatness by optical methods	12.2.5	Measurement of flatness by optical methods
5.324.1	Measurement by an autocollimator	12.2.5.1	Measurement by an autocollimator
5.324.2	Measurement by a sweep optical square	12.2.5.2	Measurement by a sweep optical square
5.324.3	Measurement by an alignment laser	12.2.5.3	Measurement by a sweeping alignment laser
5.324.4	Measurement by a laser measurement system	12.2.5.4	Measurement by a laser interferometer system
5.325	Measurement by a coordinate measuring machine		
5.33	Tolerance	4	Tolerances
5.4	Parallelism, equidistance and coincidence		
5.41	Parallelism of lines and planes	12.3.2	Parallelism of lines and planes
5.411	Definitions	3.9.3	Parallelism error between a functional line and a plane
		3.9.4	Parallelism error between two functional planes
5.412	Methods of measurement	12.3.2	Parallelism of lines and planes
5.412.1	General, for axis	12.3.2.1	General
5.412.2	Parallelism of two planes	12.3.2.2	Parallelism of two planes
5.412.21	Straightedge and dial gauge	12.3.2.2.2	Measurements using straightedge and linear displacement sensor
5.412.22	Precision level method	12.3.2.2.3	Measurement using precision level
5.412.3	Parallelism of two axes	12.3.2.3	Parallelism of two axes
5.412.31	Plane passing through two axes	12.3.2.3.2	In a plane passing through two axes
5.412.32	Second plane perpendicular to the first	12.3.2.3.3	In a second plane perpendicular to the first
5.412.4	Parallelism of an axis to a plane	12.3.2.4	Parallelism between an axis and a plane
5.412.5	Parallelism of an axis to the intersection of two planes	12.3.2.6	Parallelism between an axis and the intersection of two planes
5.412.6	Parallelism of the intersection of two planes to a third plane	12.3.2.8	Parallelism between the intersection of two planes and a third plane
5.412.7	Parallelism between two straight lines, each formed by the intersection of two planes	12.3.2.9	Parallelism between two straight lines, each formed by the intersection of two planes
5.413	Tolerances	4	Tolerances
5.42	Parallelism of motion	10.1	Parallelism of axes of motion

ISO 230-1:1996		ISO 230-1:2012	
(Sub) clause	Title	(Sub) clause	Title
5.421	Definition	3.6.1	General
		3.6.2	Parallelism error between two axes of linear motion
		3.6.3	Parallelism error between two axes of rotation
		3.6.4	Parallelism error between an axis of linear motion and an axis of rotation
		3.6.5	Parallelism error between an axis of linear motion and a surface
		3.6.6	Parallelism error between an axis of rotation and a surface
5.422	Method of measurement		
5.422.1	General	10.1.1	General
5.422.2	Parallelism between a trajectory and a plane	12.3.2.5	Parallelism between an axis of linear motion and a plane
5.422.21	Plane is on the moving component itself	12.3.2.5.1	Measurement where the plane is on the moving component itself
5.422.22	Plane is not on the moving component itself	12.3.2.5.2	Measurement where the plane is not on the moving component itself
5.422.3	Parallelism of a trajectory to an axis	10.1.3	Parallelism error between an axis of linear motion and a stationary axis
5.422.4	Parallelism of a trajectory to the intersection of two planes	12.3.2.7	Parallelism between an axis of motion and the intersection of two planes
5.422.5	Parallelism between two trajectories	10.1.2	Parallelism error between two axes of linear motion (in two planes)
5.423	Tolerance	4	Tolerances
5.43	Equidistance		
5.431	Definition	3.7.3	Equidistance error of axis average lines
5.432	Method of measurement	12.3.3	Equidistance of two axes
5.432.1	General	12.3.3.1	General
5.432.2	Special case of the equidistance of two axes from the plane of pivoting of one of the axes	12.3.3.2	Special case of the equidistance of two axes from the plane of pivoting of one of the axes
5.433	Tolerance	4	Tolerances
5.44	Coaxiality, coincidence or alignment		
5.441	Definition	3.7.2	Coaxiality error of axis average lines
		3.9.9	Coaxiality error of a functional cylinder to a datum straight line
5.442	Method of measurement	10.2	Coaxiality error of axis average lines
		12.3.4	Coaxiality
5.443	Tolerance	4	Tolerances
5.5	Squareness or perpendicularity		

ISO 230-1:1996		ISO 230-1:2012	
(Sub) clause	Title	(Sub) clause	Title
5.51	Squareness of straight lines and planes	12.4	Squareness error and perpendicularity error between lines and planes
5.511	Definition	3.9.5	Perpendicularity error between two functional lines
		3.9.6	Perpendicularity error between two functional planes
5.512	Methods of measurement	12.4	Squareness error and perpendicularity error between lines and planes
5.512.1	General	12.4.1	General
5.512.2	Two planes at 90° to each other	12.4.2	Two planes at 90° to each other
5.512.3	Two axis at 90° to each other	12.4.3	Two fixed axes at 90° to each other
5.512.31	The two axes are fixed axes		
5.512.32	One of the axes is an axis of rotation	12.4.7	Squareness between an axis of rotation and a stationary axis
5.512.4	An axis and a plane at 90° to each other		
5.512.41	Fixed axis	12.4.4	A stationary axis and a plane at 90° to each other
5.512.42	Axis of rotation	12.4.8	Squareness of an axis of rotation to a plane
5.512.5	An axis at 90° to the intersection of two planes		
5.512.51	Fixed axis	12.4.10	A fixed axis at 90° to the intersection of two planes
5.512.52	Axis of rotation	12.4.9	Squareness of an axis of rotation to the intersection of two planes
5.512.6	When the intersection of two planes is at 90° to another plane	12.4.11	When the intersection of two planes is at 90° to another plane
5.512.7	When two straight lines, each formed by the intersection of two planes, are at 90° to each other	12.4.12	When two straight lines, each formed by the intersection of two planes, are at 90° to each other
5.513	Tolerance	4	Tolerances
5.52	Perpendicularity of motion		
5.521	Definition	3.6.7	Squareness error between two axes of linear motion
		3.6.8	Squareness error between an axis of linear motion and an axis average line
		3.6.9	Squareness error between two axis average lines
5.522	Methods of measurement	10.3	Squareness error of axes of motion
5.522.1	General	10.3.1	General
5.522.2	Perpendicularity between the trajectory of a point and a plane	12.4.5	Squareness error between an axis of linear motion and a plane
5.522.3	Trajectory of a point at 90° to an axis	12.4.6	Squareness error between an axis of linear motion and a stationary axis
5.522.4	Two trajectories perpendicular to each other	10.3.2	Squareness error between two axes of linear motion

ISO 230-1:1996		ISO 230-1:2012	
(Sub) clause	Title	(Sub) clause	Title
5.523	Tolerance	4	Tolerances
5.6	Rotation	9	Geometric accuracy tests of axes of rotation
5.61	Run-out		
5.611	Definition	3.9.7	Run-out of a functional surface at a given section
5.611.1	Out-of-round		
5.611.2	Eccentricity	3.5.9	Eccentricity of a driven axis
5.611.3	Radial throw of an axis at a given point	3.5.10	Radial throw of a rotary axis at a given point
5.611.4	Run-out of a component at a given section		
5.612	Methods of measurement	12.5	Run-out of rotational components
5.612.1	Precautions before testing	12.5.1	Precautions before testing (see 6.22 for temperature conditions of certain components before test)
5.612.2	External surface	12.5.2	External surface
5.612.3	Internal surface	12.5.3	Internal surface
5.613	Tolerance	4	Tolerances
5.62	Periodic axial slip		
5.621	Definitions		
5.621.1	Minimum axial play		
5.621.2	Periodic axial slip	3.5.5	Axial error motion
5.622	Methods of measurement	9.1	Reference to ISO 230-7
5.622.1	General		
5.622.2	Applications		
5.623	Tolerance	4	Tolerances
5.63	Camming	9.1	Reference to ISO 230-7
5.631	Definitions		
5.632	Method of measurement		
5.633	Tolerance	4	Tolerances
6	Special tests		
6.1	Division		
6.11	Definition of errors		
6.111	Individual error of division		
6.112	Successive error of division		
6.113	Local error of division		
6.114	Cumulative error		
6.115	Total error of division		
6.116	Graphical representation of these errors		
6.12	Methods of measurement		

ISO 230-1:1996		ISO 230-1:2012	
(Sub) clause	Title	(Sub) clause	Title
6.13	Tolerance	4	Tolerances
6.2	Determination of the linear positioning deviations of screw-driven components		
6.3	Angular play		
6.31	Definition		
6.32	Method of measurement (testing of the indexing device/components)		
6.33	Tolerance	4	Tolerances
6.4	Repeatability of devices with angular indexing	9.1	Reference to ISO 230-7
6.41	Definition		
6.42	Method of measurement		
6.43	Tolerance	4	Tolerances
6.5	Intersection of axes		
6.51	Definition	3.7.4	Error of intersection between axis average lines
6.52	Method of measurement	10.4	Intersection of axis average lines
6.521	Direct measurement	10.4.3	Intersection of non-square axis average lines
6.522	Indirect measurement	10.4.4	Indirect measurement
6.53	Tolerance	4	Tolerances
6.6	Circularity		
6.61	Definition	3.8.2	Circular error
6.62	Method of measurement on test pieces	Annex B	Test piece measurement
6.621	Circularity measuring machine with rotating pickup or rotating table		
6.622	Coordinate measuring machine		
6.623	Projection of the profile		
6.624	Vee-block method		
6.63	Measurement of numerically controlled (NC) circular movement	11.3	Circular trajectories
6.631	Rotating one-dimensional probe	11.3.4.2	Method using rotating one-dimensional linear displacement sensor
6.632	Circular master and two-dimensional probe	11.3.4.3	Method using circular master and two-dimensional displacement sensor
6.633	Telescopic ball bar	11.3.4.4	Method using telescoping ball bar
6.7	Cylindricity		
6.71	Definition		
6.72	Method of measurement		
6.721	Coordinate measuring machine		
6.722	Circularity measuring machine with rotating pickup or rotating table		
6.723	Vee-block method		

ISO 230-1:1996		ISO 230-1:2012	
(Sub) clause	Title	(Sub) clause	Title
6.8	Consistency of machined diameter	B.2.3	Consistency of machined diameters
6.81	Definition		
6.82	Method of measurement		
6.821	Micrometer or similar two-point measuring instrument	B.2.3.2	Micrometer or similar two-point measuring instrument
6.822	Height gauge		

Bibliography

- [1] ISO/IEC Guide 98-3, *Uncertainty of measurement — Part 3: Guide to the expression of uncertainty in measurement (GUM:1995)*
- [2] ISO/IEC Guide 99, *International vocabulary of metrology — Basic and general concepts and associated terms (VIM)*
- [3] ISO/TR 5460, *Technical drawings — Geometrical tolerancing — Tolerancing of form, orientation, location and run-out — Verification principles and methods — Guidelines*
- [4] ISO 14253-2, *Geometrical product specifications (GPS) — Inspection by measurement of workpieces and measuring equipment — Part 2: Guidance for the estimation of uncertainty in GPS measurement, in calibration of measuring equipment and in product verification*
- [5] ISO 14253-3, *Geometrical product specifications (GPS) — Inspection by measurement of workpieces and measuring equipment — Part 3: Guidelines for achieving agreements on measurement uncertainty statements*
- [6] ISO/TS 14253-4, *Geometrical product specifications (GPS) — Inspection by measurement of workpieces and measuring equipment — Part 4: Background on functional limits and specification limits in decision rules*
- [7] KNAPP, W. *Measurement Uncertainty and Machine Tool Testing*, CIRP Annals, 51(1), 2002, pp. 459-462
- [8] KNAPP, W., BRINGMANN, B. Straightness Measurements for Long Movements. *Nanotechnology and Precision Engineering* 3 (2005), pp. 249-256
- [9] BELL, S. *A beginner's Guide to Uncertainty of Measurement*. published by NPL
(see http://www.wmo.int/pages/prog/gcos/documents/gruanmanuals/UK_NPL/mgpg11.pdf)
- [10] BRYAN, J.B. The Abbé principle revisited: An updated interpretation, *Precision Engineering*, 1(3), 1979
- [11] ESTLER, W.T., EDMUNDSON, K.L., PEGGS, G.N., PARKER, D.H. Large Scale Metrology: An Update. *CIRP Annals*, 51(2), 2002, pp. 587-609
- [12] INASAKI, I., KISHINAMI, K., SAKAMOTO, S., SUGIMURA, N., TAKEUCHI, Y., and TANAKA, F., *Form shaping theory of machine tools: fundamentals and applications*. Yokendo, Tokyo, 1997 (in Japanese)

Index

Alphabetical index of terms and definitions

- A**
- angular deviation 3.4.17
 - angular error motions of a linear axis 3.4.16
 - angular error of a linear axis 3.4.18
 - angular positioning deviation 3.5.12
 - angular positioning error 3.5.13
 - angular positioning error motion 3.5.11
 - axial error motion 3.5.5
 - axis average line 3.5.3
 - axis of rotation 3.5.2
 - axis of rotation error motion 3.5.4
 - axis shift 3.5.8
- B**
- bidirectional repeatability of angular indexing 3.5.15
- C**
- circular error 3.8.2
 - coaxiality error of axis average lines 3.7.2
 - coaxiality error of a functional cylinder to a datum straight line 3.9.9
- E**
- eccentricity of a driven axis 3.5.9
 - error motions of a linear axis 3.4.3
 - end-point reference straight line 3.4.15
 - error of intersection between axis average lines 3.7.4
 - equidistance error of axis average lines 3.7.3
- F**
- flatness 3.8.5
 - flatness deviation 3.8.7
 - flatness error of a functional surface 3.9.8
 - flatness error of a surface defined by two linear motions 3.8.11
 - functional point 3.4.2
- H**
- hysteresis 3.3.4
- L**
- least squares circle 3.8.4
 - least squares reference straight line 3.4.14
 - least squares zone reference plane 3.8.10
 - linear error motions of a linear axis 3.4.4
 - linear positioning deviation 3.4.6
 - linear positioning error 3.4.7
 - linear positioning error motion 3.4.5
- M**
- machine hysteresis 3.3.6
 - mean minimum zone circle 3.8.3
 - mean minimum zone reference plane 3.8.9
 - mean minimum zone reference straight line 3.4.13
- O**
- offset between two axis average lines 3.7.1
- P**
- parallelism error between an axis of linear motion and an axis of rotation 3.6.4
- R**
- parallelism error between an axis of linear motion and a surface 3.6.5
 - parallelism error between an axis of rotation and a surface 3.6.6
 - parallelism error between a functional line and a plane 3.9.3
 - parallelism error between two axes of linear motion 3.6.2
 - parallelism error between two axes of rotation 3.6.3
 - parallelism error between two functional planes 3.9.4
 - perpendicularity error between two functional lines 3.9.5
 - perpendicularity error between two functional planes 3.9.6
 - play 3.3.3
 - radial error motion 3.5.6
 - radial throw of a rotary axis at a given point 3.5.10
 - reference plane 3.8.8
 - reference straight line 3.4.12
 - run-out of a functional surface at a given section 3.9.7
- S**
- setup hysteresis 3.3.5
 - squareness error between an axis of linear motion and an axis average line 3.6.8
 - squareness error between two axis average lines 3.6.9
 - squareness error between two axes of linear motion 3.6.7
 - static compliance 3.3.2
 - straightness 3.4.11
 - straightness deviation 3.4.9
 - straightness error motion 3.4.8
 - straightness error of a functional line in a plane 3.9.2
 - straightness error of a linear axis 3.4.10
 - structural loop 3.3.1

**surface generated by two linear
motions** 3.8.6
synchronous motion 3.8.1

U

**unidirectional repeatability of
angular indexing** 3.5.14

V

volumetric accuracy 3.8.12
volumetric performance 3.8.13

British Standards Institution (BSI)

BSI is the independent national body responsible for preparing British Standards and other standards-related publications, information and services. It presents the UK view on standards in Europe and at the international level.

BSI is incorporated by Royal Charter. British Standards and other standardisation products are published by BSI Standards Limited.

Revisions

British Standards and PASs are periodically updated by amendment or revision. Users of British Standards and PASs should make sure that they possess the latest amendments or editions.

It is the constant aim of BSI to improve the quality of our products and services. We would be grateful if anyone finding an inaccuracy or ambiguity while using British Standards would inform the Secretary of the technical committee responsible, the identity of which can be found on the inside front cover. Similar for PASs, please notify BSI Customer Services.

Tel: +44 (0)20 8996 9001 Fax: +44 (0)20 8996 7001

BSI offers BSI Subscribing Members an individual updating service called PLUS which ensures that subscribers automatically receive the latest editions of British Standards and PASs.

Tel: +44 (0)20 8996 7669 Fax: +44 (0)20 8996 7001

Email: plus@bsigroup.com

Buying standards

You may buy PDF and hard copy versions of standards directly using a credit card from the BSI Shop on the website www.bsigroup.com/shop. In addition all orders for BSI, international and foreign standards publications can be addressed to BSI Customer Services.

Tel: +44 (0)20 8996 9001 Fax: +44 (0)20 8996 7001

Email: orders@bsigroup.com

In response to orders for international standards, BSI will supply the British Standard implementation of the relevant international standard, unless otherwise requested.

Information on standards

BSI provides a wide range of information on national, European and international standards through its Knowledge Centre.

Tel: +44 (0)20 8996 7004 Fax: +44 (0)20 8996 7005

Email: knowledgecentre@bsigroup.com

BSI Subscribing Members are kept up to date with standards developments and receive substantial discounts on the purchase price of standards. For details of these and other benefits contact Membership Administration.

Tel: +44 (0)20 8996 7002 Fax: +44 (0)20 8996 7001

Email: membership@bsigroup.com

Information regarding online access to British Standards and PASs via British Standards Online can be found at www.bsigroup.com/BSOL

Further information about British Standards is available on the BSI website at www.bsi-group.com/standards

Copyright

All the data, software and documentation set out in all British Standards and other BSI publications are the property of and copyrighted by BSI, or some person or entity that own copyright in the information used (such as the international standardisation bodies) has formally licensed such information to BSI for commercial publication and use. Except as permitted under the Copyright, Designs and Patents Act 1988 no extract may be reproduced, stored in a retrieval system or transmitted in any form or by any means – electronic, photocopying, recording or otherwise – without prior written permission from BSI. This does not preclude the free use, in the course of implementing the standard, of necessary details such as symbols, and size, type or grade designations. If these details are to be used for any other purpose than implementation then the prior written permission of BSI must be obtained. Details and advice can be obtained from the Copyright & Licensing Department.

Tel: +44 (0)20 8996 7070

Email: copyright@bsigroup.com

BSI

389 Chiswick High Road London W4 4AL UK

Tel +44 (0)20 8996 9001

Fax +44 (0)20 8996 7001

www.bsigroup.com/standards