

# Technical drawings — Indication of dimensions and tolerances —

## Part 1: General principles

ICS 01.100.01

## National foreword

This British Standard reproduces verbatim ISO 129-1:2004 and implements it as the UK national standard. It supersedes BS ISO 129:1985 which is withdrawn.

The UK participation in its preparation was entrusted to Technical Committee TDW/4, Technical product specification, methodology, presentation and verification, which has the responsibility to:

- aid enquirers to understand the text;
- present to the responsible international/European committee any enquiries on the interpretation, or proposals for change, and keep the UK interests informed;
- monitor related international and European developments and promulgate them in the UK.

A list of organizations represented on this committee can be obtained on request to its secretary.

### Cross-references

The British Standards which implement international publications referred to in this document may be found in the *BSI Catalogue* under the section entitled “International Standards Correspondence Index”, or by using the “Search” facility of the *BSI Electronic Catalogue* or of British Standards Online.

This publication does not purport to include all the necessary provisions of a contract. Users are responsible for its correct application.

**Compliance with a British Standard does not of itself confer immunity from legal obligations.**

### Summary of pages

This document comprises a front cover, an inside front cover, the ISO title page, pages ii to iv, pages 1 to 33 and a back cover.

The BSI copyright notice displayed in this document indicates when the document was last issued.

### Amendments issued since publication

Amd. No.	Date	Comments

This British Standard was published under the authority of the Standards Policy and Strategy Committee on 25 November 2004

© BSI 25 November 2004

ISBN 0 580 44886 X

# INTERNATIONAL STANDARD

# ISO 129-1

First edition  
2004-09-15

---

---

## Technical drawings — Indication of dimensions and tolerances —

### Part 1: General principles

*Dessins techniques — Indication des cotes et tolérances —  
Partie 1: Principes généraux*



Reference number  
ISO 129-1:2004(E)



# Contents

Page

Foreword.....	iv
1 Scope.....	1
2 Normative references .....	1
3 Terms and definitions.....	2
3.1 Features .....	2
3.2 Lines of dimensioning.....	2
3.3 Dimensions.....	3
3.4 Arrangement of dimensions .....	3
4 Principles of dimensioning and of indication of tolerances.....	4
4.1 General principles.....	4
4.2 Positioning of dimensions .....	4
4.3 Units of dimensions.....	5
5 Elements of dimensioning .....	6
5.1 General.....	6
5.2 Dimension line.....	6
5.3 Terminators and origin indication.....	9
5.4 Extension line.....	9
5.5 Leader line .....	11
5.6 Dimensional values (basic dimensions).....	11
5.7 Letters representing dimensions .....	14
5.8 Tabular dimensioning.....	14
6 Elements of indication of tolerances .....	15
6.1 General rules .....	15
6.2 Limit deviations.....	15
6.3 Limits of dimension .....	16
7 Indications of special dimensions .....	16
7.1 Arrangement of graphical and letter symbols with dimensional values.....	16
7.2 Diameters .....	17
7.3 Radii.....	18
7.4 Spheres .....	18
7.5 Arcs, chords and angles .....	18
7.6 Squares .....	20
7.7 Equally spaced and repeated features .....	20
7.8 Symmetrical parts.....	24
7.9 Indication of levels.....	25
7.10 Dimensions of out-of-scale represented features .....	25
7.11 Auxiliary dimensions.....	25
8 Arrangements of dimensions .....	25
8.1 General.....	25
8.2 Parallel dimensioning.....	25
8.3 Running dimensioning .....	26
8.4 Chain dimensioning.....	27
8.5 Coordinate dimensioning.....	28
8.6 Combined dimensioning .....	30
Annex A (normative) Relations and dimensions of graphical symbols .....	31
Bibliography .....	33

## Foreword

ISO (the International Organization for Standardization) is a worldwide federation of national standards bodies (ISO member bodies). The work of preparing International Standards is normally carried out through ISO technical committees. Each member body interested in a subject for which a technical committee has been established has the right to be represented on that committee. International organizations, governmental and non-governmental, in liaison with ISO, also take part in the work. ISO collaborates closely with the International Electrotechnical Commission (IEC) on all matters of electrotechnical standardization.

International Standards are drafted in accordance with the rules given in the ISO/IEC Directives, Part 2.

The main task of technical committees is to prepare International Standards. Draft International Standards adopted by the technical committees are circulated to the member bodies for voting. Publication as an International Standard requires approval by at least 75 % of the member bodies casting a vote.

Attention is drawn to the possibility that some of the elements of this document may be the subject of patent rights. ISO shall not be held responsible for identifying any or all such patent rights.

ISO 129-1 was prepared by Technical Committee ISO/TC 10, *Technical product documentation*, Subcommittee SC 1, *Basic conventions*.

This part of ISO 129, together with ISO 129-2, cancels and replaces ISO 129:1985 and ISO 406:1987 of which it constitutes a technical revision.

ISO 129 consists of the following parts, under the general title *Technical drawings — Indication of dimensions and tolerances*:

- *Part 1: General principles*
- *Part 2: Mechanical engineering*

# Technical drawings — Indication of dimensions and tolerances —

## Part 1: General principles

### 1 Scope

This part of ISO 129 establishes the general principles of dimensioning applicable for all types of technical drawings.

NOTE The figures in this part of ISO 129 merely illustrate the text and are not intended to reflect actual usage. Consequently, they have been simplified to indicate only the relevant general principles applicable in any technical area.

Additional and more specific rules and details about the use of dimensioning for construction engineering are given in ISO 6284. For mechanical engineering, they will be given in the future ISO 129-2.

### 2 Normative references

The following referenced documents are indispensable for the application of this document. For dated references, only the edition cited applies. For undated references, the latest edition of the referenced document (including any amendments) applies.

ISO 128-20:1996, *Technical drawings — General principles of presentation — Part 20: Basic conventions for lines*

ISO 128-22:1999, *Technical drawings — General principles of presentation — Part 22: Basic conventions and applications for leader lines and reference lines*

ISO 128-30:2001, *Technical drawings — General principles of presentation — Part 30: Basic conventions for views*

ISO 1000:1992, *SI units and recommendations for the use of their multiples and of certain other units*

ISO 3098-0:1997, *Technical product documentation — Lettering — Part 0: General requirements*

ISO 3098-5:1997, *Technical product documentation — Lettering — Part 5: CAD lettering of the Latin alphabet, numerals and marks*

ISO 6284:1996, *Construction drawings — Indication of limit deviations*

ISO 6412-2:1989, *Technical drawings — Simplified representation of pipelines — Part 2: Isometric projection*

ISO 6428:1982, *Technical drawings — Requirements for microcopying*

ISO 10209-2:1993, *Technical product documentation — Vocabulary — Part 2: Terms relating to projection methods*

ISO/IEC 81714-1, *Design of graphical symbols for use in the technical documentation of products — Part 1: Basic rules*

### 3 Terms and definitions

For the purposes of this part of ISO 129, the following terms and definitions apply.

#### 3.1 Features

##### 3.1.1

##### **geometrical feature**

point, line or surface

[ISO 14660-1:1999, definition 2.1]

NOTE The word geometrical may be deleted if no risk of misunderstanding occurs, hence, in this standard the word “feature” will be used alone.

##### 3.1.2

##### **feature of size**

geometrical shape defined by a linear or angular dimension which is a size

[ISO 14660-1:1999, definition 2.2]

NOTE 1 The feature of size can be a cylinder, a sphere, two parallel opposite surfaces, a cone or a wedge.

NOTE 2 In International Standards such as ISO 286-1 and ISO/R 1938-1, the meanings of the terms “plain workpiece” and “single features” are close to that of “feature of size”.

##### 3.1.3

##### **reference feature**

feature which is used as the origin for the determination of another feature

##### 3.1.4

##### **repeated feature**

periodicity of features of the same spacing or angle referred to one or more reference features

#### 3.2 Lines of dimensioning

##### 3.2.1

##### **centre line**

line on a drawing indicating the geometrical centre of the represented feature(s)

##### 3.2.2

##### **dimension line**

straight or curved line on a drawing between two features, or between a feature and an extension line, or between two extension lines indicating the dimension graphically

NOTE The dimensional value and any tolerance indication are attached to the dimension line.

##### 3.2.3

##### **extension line**

line connecting the feature(s) to be dimensioned and the ends of the corresponding dimension line

##### 3.2.4

##### **leader line**

line connecting information or requirements or a reference line with a feature or a dimension line

NOTE Adapted from ISO 128-22:1999.



**3.2.5****line of symmetry**

straight line on a drawing indicating the plane or axis of symmetry

**3.2.6****origin circle**

starting point of running dimensioning or coordinate dimensioning

**3.2.7****terminator**

indication signifying the extremities of a dimension or leader line

**3.3 Dimensions****3.3.1****dimension**

distance between two features or the size of a feature of size

NOTE Linear and angular dimensions exist.

**3.3.2****basic dimension****dimensional value**

numerical value of a dimension expressed in a specific unit and indicated on drawings with lines and relevant symbols

NOTE 1 When no tolerance is indicated, the basic dimension is often called the dimensional value.

NOTE 2 Unit of dimension should be linear or angular.

NOTE 3 The tolerance limits and/or permissible deviations are applied to the basic dimension.

**3.3.3****linear dimension**

linear distance between two features or the linear size of a feature of size

NOTE In mechanical engineering drawings, linear dimensions are classified in size, distances and radii (ISO/TR 14638).

**3.3.4****angular dimension**

the angle between two features or the angle of an angular feature of size

NOTE In mechanical engineering drawings, angular dimensions are classified in angular size and angular distances (ISO/TR 14638).

**3.3.5****tolerance of dimension**

difference between the upper and lower tolerance limits of a dimension

**3.3.6****auxiliary dimension**

dimensions derived from other dimensions given for information purposes only

**3.4 Arrangement of dimensions****3.4.1****chain dimensioning**

method of dimensioning where single dimensions are arranged in a row

**3.4.2**

**coordinate dimensioning**

method of dimensioning from a reference feature in a coordinate system

EXAMPLE Cartesian or polar coordinates, see ISO 10209-2.

**3.4.3**

**parallel dimensioning**

method of dimensioning from a reference feature with parallel or concentric dimension lines

**3.4.4**

**running dimensioning**

method of dimensioning from a reference feature where each feature is dimensioned

**3.4.5**

**tabular dimensioning**

method of dimensioning where features and/or dimensions are indicated by allocated numbers or letters and recorded in tables

## **4 Principles of dimensioning and of indication of tolerances**

### **4.1 General principles**

All dimensions, graphical symbols and annotations shall be indicated such that they can be read from the bottom or right-hand side (main reading directions) of the drawing.

Dimensions are one of several types of geometrical requirements, which may be used to define a feature or component clearly and unambiguously. Other types of geometrical requirements, which most often are needed to obtain an unambiguous definition of the feature (e.g. in mechanical engineering) are geometrical tolerances (form, orientation, location and run-out), surface texture requirements and requirements for corners.

NOTE In the construction engineering, tolerances are often given in separate documents.

All dimensional information shall be complete and shown directly on a drawing unless this information is specified in related associated documentation.

Each feature or relation between features shall be dimensioned only once.

Where all linear dimensions are expressed in the same unit, the unit symbol may be omitted, provided the drawing or associated documentation carries a statement of the unit used.

### **4.2 Positioning of dimensions**

Dimensions should be placed on that view or section which shows the relevant feature(s) most clearly (see Figure 1).

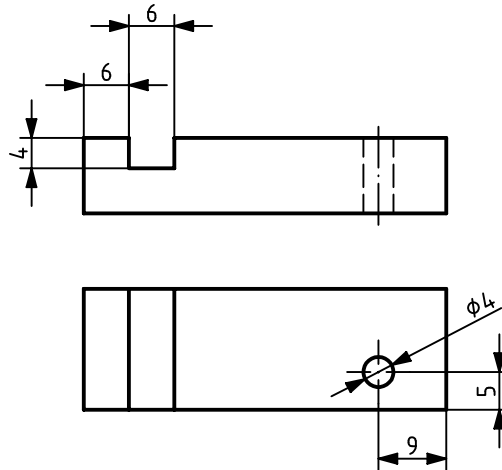

Figure 1

Where several features or objects are depicted in close proximity, their relative dimensions should be grouped together, separately, for ease of reading (see Figure 2).

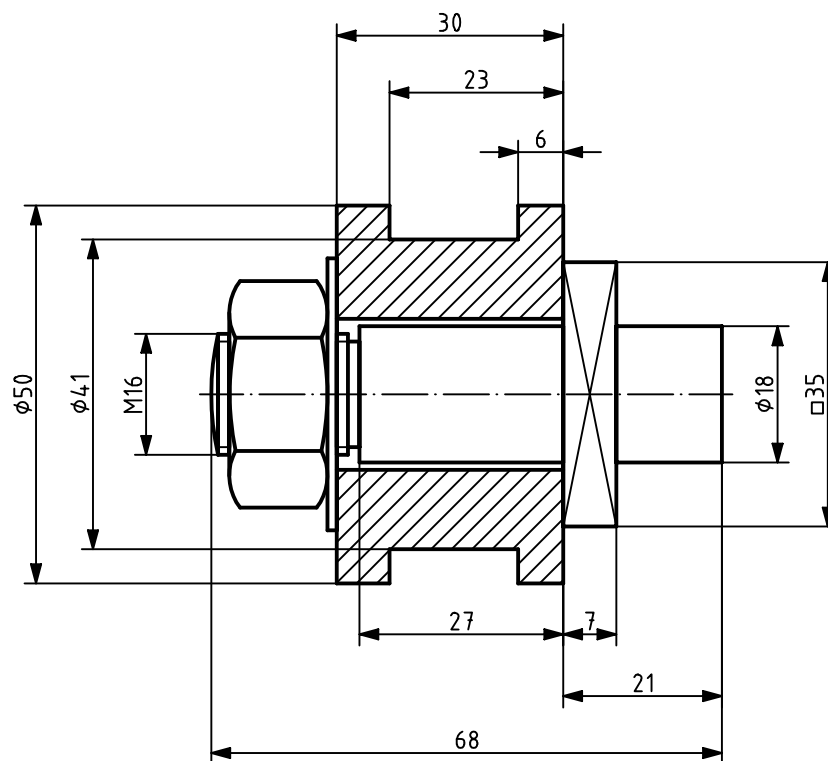

Figure 2

### 4.3 Units of dimensions

Dimensions shall be indicated using only one unit of dimension. Where a variety of units of dimension are used within one document, they shall be clearly indicated.

For dimensions, SI units shall be used; see ISO 1000 or other International Standards relevant for SI units.

Limit deviations shall be expressed in the same unit as the basic dimension.

## 5 Elements of dimensioning

### 5.1 General

The elements of dimensioning are extension lines, dimension lines, leader lines, terminators, indication of origins and dimensional values (basic dimensions). Various elements of dimensioning are illustrated in Figure 3; the origin circle is indicated in Figures 62 to 64.

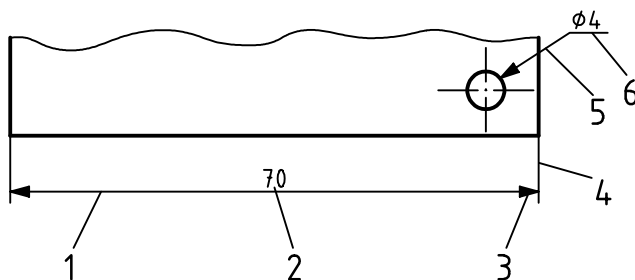

#### Key

- 1 dimension line
- 2 dimensional value
- 3 terminator (in this case, an arrowhead)
- 4 extension line
- 5 leader line
- 6 reference line

Figure 3

### 5.2 Dimension line

Dimension lines shall be drawn with a continuous narrow line according to ISO 128-20.

Dimension lines shall be indicated in the case of

- linear dimensions parallel to the length to be dimensioned (see Figure 4),
- angular dimensions or dimensions of an arc as a circular arc around the vertex of the angle or the centre of the arc (see Figures 5 and 6), and
- radii generated from the geometrical centre of the radius (see Figure 6).

Where space is limited, dimension lines may be indicated with extensions and reversed arrowheads (see Figure 1).

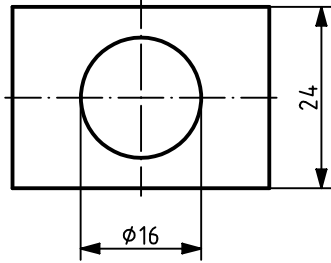

Figure 4

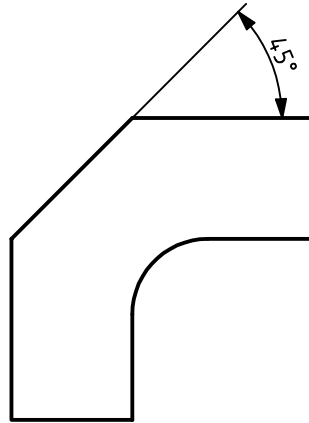

Figure 5

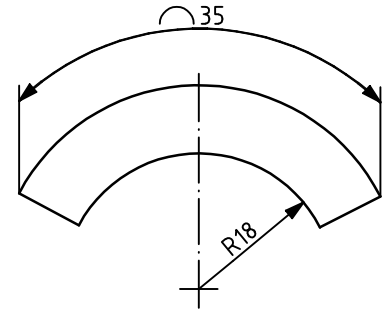

Figure 6

Where the feature is shown broken, the corresponding dimension line shall be shown unbroken (see Figure 7).

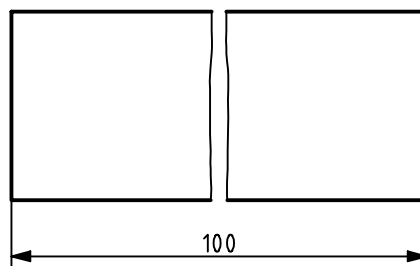

Figure 7

Intersection of dimension lines with any other line should be avoided, but where intersection is unavoidable they shall be shown without a break (see Figure 8).

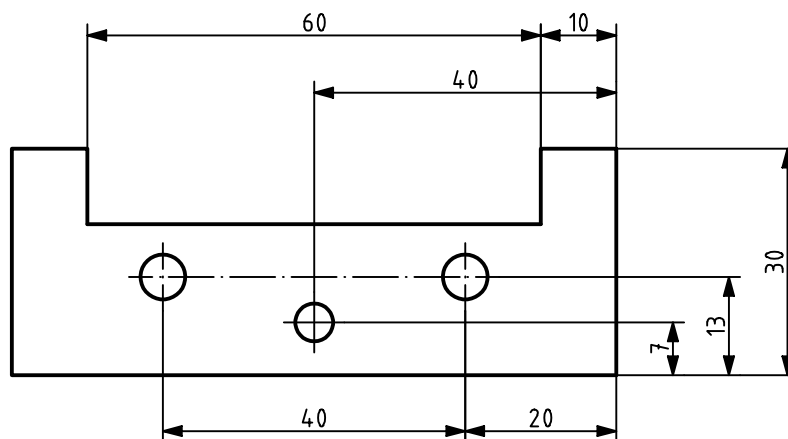

Figure 8

Dimension lines may be shown not in full, when

- dimensions of diameters are indicated (see Figure 9),
- only a part of a symmetrical feature is drawn in a view or section (see Figures 55 and 56),
- a feature is drawn half in a view and half in a cut (see Figure 9),
- the reference feature for dimensioning is not on the drawing sheet and there is no need for its indication (see Figure 40 R62),
- referring to grids on construction drawings (see Figure 10).

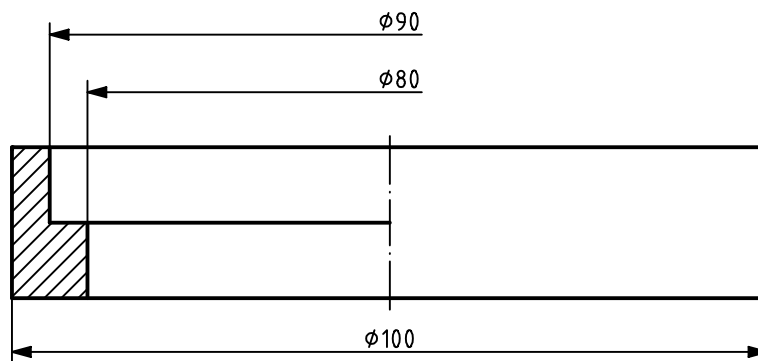

Figure 9

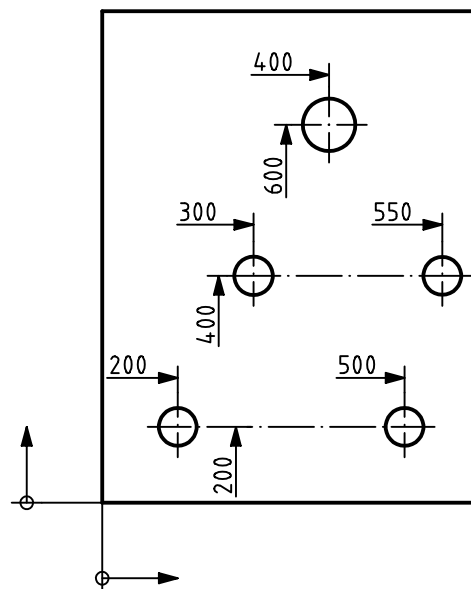

Figure 10

### 5.3 Terminators and origin indication

5.3.1 The size ratios of the terminators illustrated in Figure 11 and of the origin circle illustrated in Figure 12 are given in Annex A.

5.3.2 The termination of dimension lines shall be according to one of the representations shown in Figure 11.

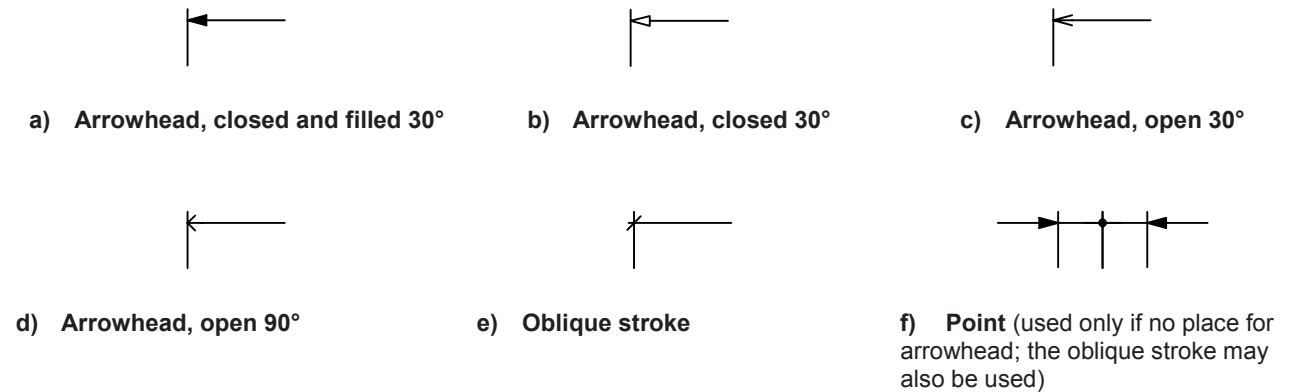

Figure 11

5.3.3 The indication of the origin of the dimension line shall be as shown in Figure 12.

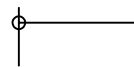

Figure 12

### 5.4 Extension line

Extension lines shall be drawn as continuous narrow lines according to ISO 128-20.

Extension lines shall extend approximately 8 times the line width beyond the respective dimension line.

Extension lines should be drawn perpendicular to the corresponding physical length (see Figures 4 and 5, 7 to 9 and 13).

It is permissible to have a gap (approximately 8 times the line width) between the feature and the beginning of the extension line in certain technical fields (see Figure 14).

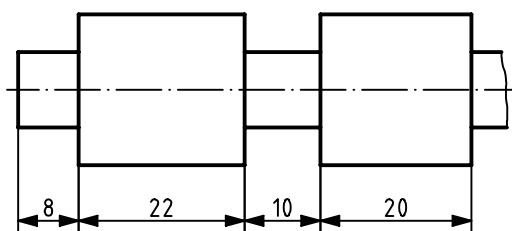

Figure 13

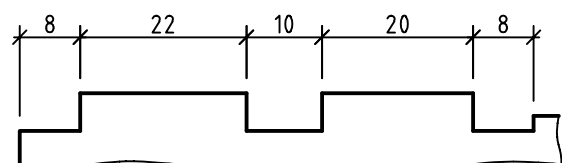

Figure 14

The extension lines may be drawn obliquely, but parallel to each other (see Figure 15).

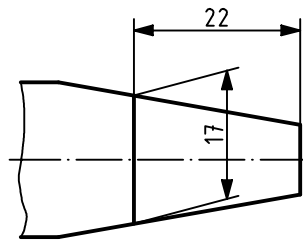

Figure 15

Intersecting projected contours of outlines shall extend approximately 8 times the line width beyond the point of intersection (see Figure 16).

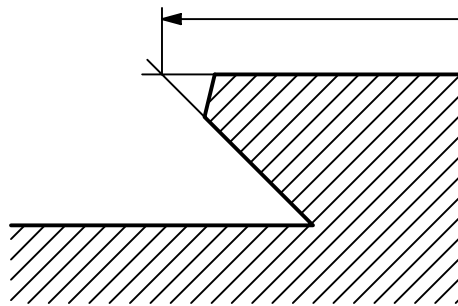

Figure 16

In the case of projected contours of transitions and similar features, the extension lines apply at the point of intersection of the projection lines (see Figure 17).

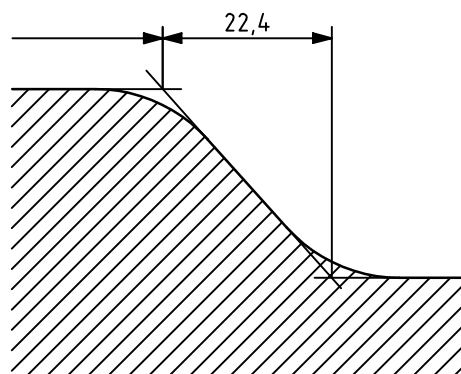

Figure 17



Extension lines may be interrupted if their continuation is unambiguous (see Figures 18 and 19). In the case of angular dimensions, the extension lines are the extensions of the angle legs (see Figure 19).

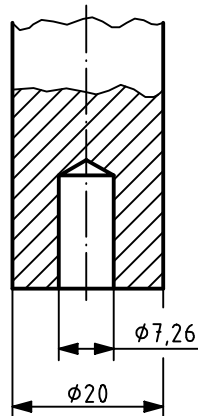

Figure 18

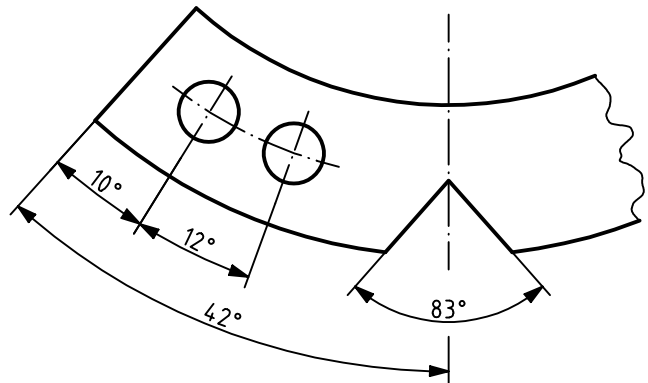

Figure 19

## 5.5 Leader line

Leader lines according to ISO 128-22 shall be drawn using a continuous narrow line according to ISO 128-20. Leader lines should not be longer than necessary and should be drawn obliquely to the feature, but shall have an angle distinctive from that of any existing hatching (see Figures 20, 25 and 27).

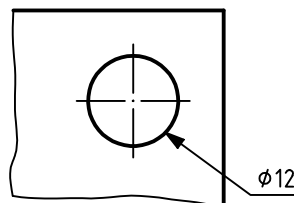

Figure 20

## 5.6 Dimensional values (basic dimensions)

### 5.6.1 Indication

Dimensional values shall be indicated on drawings in characters of sufficient size to ensure complete legibility on the original drawing as well as on reproductions made from microfilms (see ISO 6428). Lettering B vertical according to ISO 3098-0 is recommended.

5.6.2 Positions of dimensional values

Dimensional values shall be placed parallel to their dimension line and near the middle of and slightly above that line (see Figures 21 and 22 and Annex A).

Dimensional values shall be placed in such a way that they are not crossed or separated by any line.

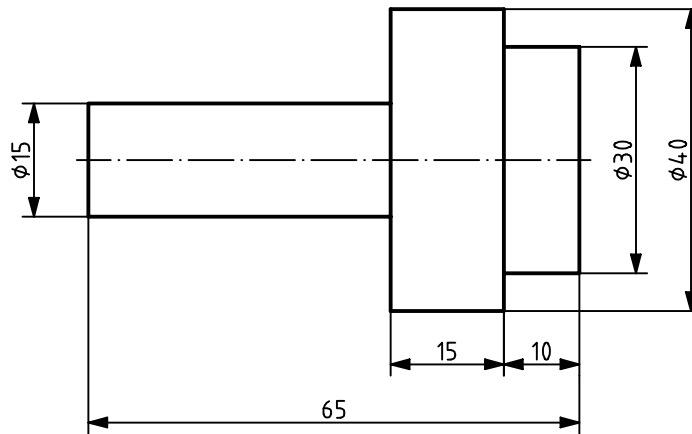

Figure 21

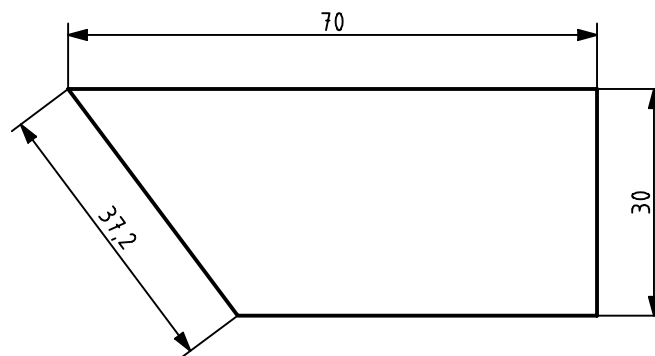

Figure 22

For exceptions, see 5.6.3.

Values on oblique dimension lines shall be oriented as shown in Figure 23.

Values of angular dimensions shall be oriented as shown in Figure 24.

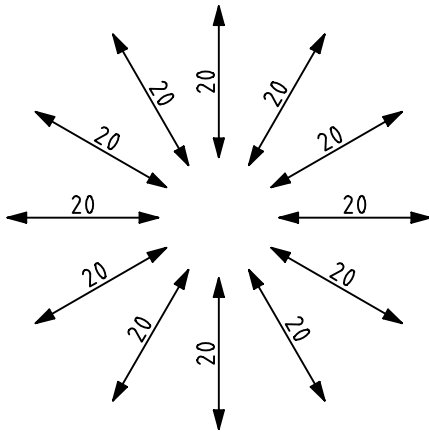

Figure 23

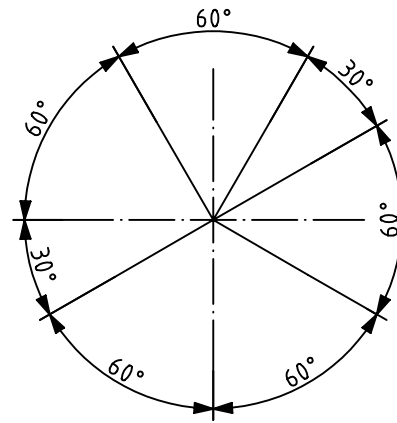

Figure 24

### 5.6.3 Special positions of dimensional values

The position of dimensional values frequently needs adaptation to different situations:

- dimensional values can be above the extension of the dimension line beyond one of the terminators, if space is limited (see Figure 25);
- dimensional values can be shown on a reference line, and attached to the dimension line by a leader line, terminating on the dimension line that is too short for the dimensional value to be indicated in the usual way between the extension lines (see Figure 25);

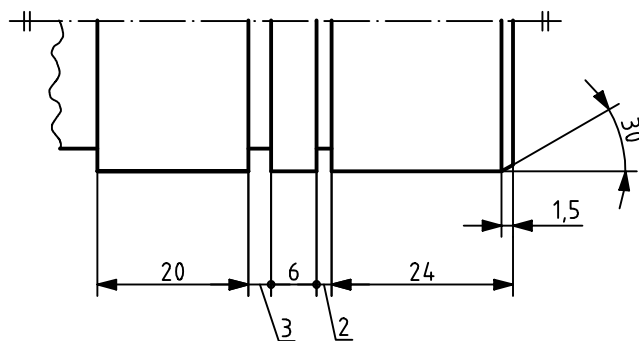

Figure 25

- c) dimensional values can be placed above a horizontal extension of a dimension line where space does not allow placement parallel to the dimension line (see Figure 26);

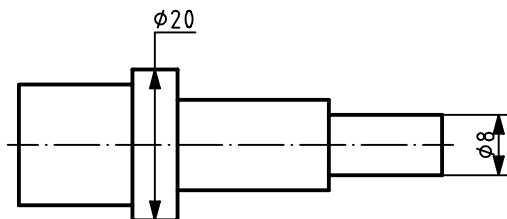

Figure 26

- d) in running dimensioning, the values shall be indicated near the arrowhead (see Figures 63 and 64).

### 5.7 Letters representing dimensions

Letters may be used to represent dimensional values and these shall be defined on the same drawing or in associated documentation (see Figure 27).

### 5.8 Tabular dimensioning

This method of dimensioning enables a series of variable common features of a feature or assembly to be presented in tabular form (see Figure 27).

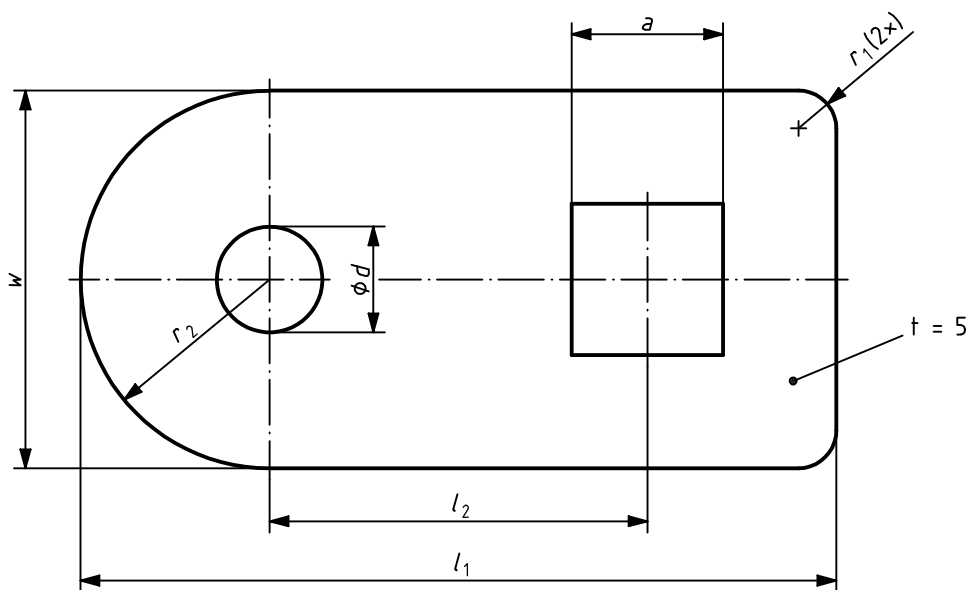

No.	$a$	$d$	$l_1$	$l_2$	$r_1$	$r_2$	$w$
1	□ 2	∅ 10	100	50	R6	(R16)	32
2	□ 6	∅ 16	120	64	R6	(R20)	40
3	□ 8	∅ 20	140	78	R8	(R24)	48

Figure 27

## 6 Elements of indication of tolerances

### 6.1 General rules

When general tolerances, according to, e.g. ISO 2768-1 and ISO 2768-2, are indicated on a drawing, they shall be stated inside or near the title block.

The symbols of, for example, tolerance classes and the digits indicating the permissible deviations, shall be written in the same lettering height as the basic dimension. It is also permitted to use a lettering height which is one size smaller than the lettering height of the basic dimension, but not smaller than 2,5 mm.

Depending on the field of application, the tolerances of dimensions may be indicated by

- symbols of the tolerance classes (ISO 2768-1 and ISO 2768-2),
- limit deviation (see 6.2),
- limits of dimension (see 6.3), or
- statistical tolerancing.

All tolerances apply to the represented state of the feature in the technical drawing.

### 6.2 Limit deviations

The components of the toleranced dimension shall be indicated in the following order (see Figures 28 to 31):

- a) the basic dimension;
- b) the limit deviations.

Limit deviations, according to ISO 286-1, shall be indicated either by indicating the upper deviation above the lower deviation (see Figures 28 and 30), or by indicating the upper deviation before the lower deviation on the same line, separated from it by a slash (see Figure 29).

If one of the two limit deviations is zero, this shall be expressed by the digit zero (see Figure 30).

If the tolerance is symmetrical in relation to the basic dimension, the limit deviation shall be indicated once only, preceded by the sign “±” (see Figure 31).

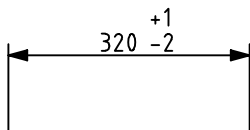

Figure 28

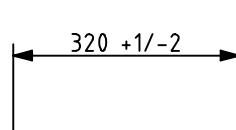

Figure 29

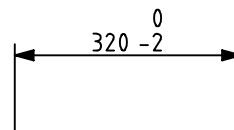

Figure 30

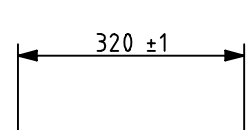

Figure 31

### 6.3 Limits of dimensions

6.3.1 The limits of dimensions are indicated by a maximum and a minimum (see Figure 32).

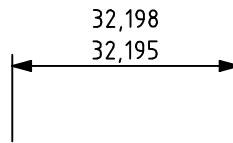

Figure 32

6.3.2 To limit the dimension in one direction only, this should be indicated by adding “min.” or “max.” to the dimensional value (see Figure 33).

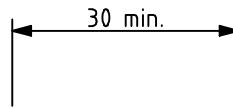

Figure 33

6.3.3 For limit deviations for angular dimensions, see 7.5.

## 7 Indications of special dimensions

### 7.1 Arrangement of graphical and letter symbols with dimensional values

The following symbols shall be used with dimensions to identify the shape of a dimensioned feature. The following symbols shall precede the dimensional value (see Figure 6, Figures 34 to 38 and Table A.1):

- $\varnothing$ : Diameter;
- R: Radius;
- $\square$ : Square;
- $S\varnothing$ : Spherical diameter;
- SR: Spherical radius;
- $\frown$ : Arc;
- t =: Thickness.

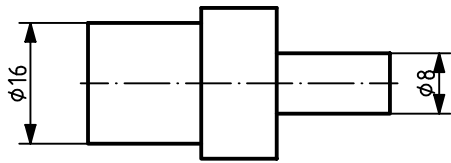

Figure 34

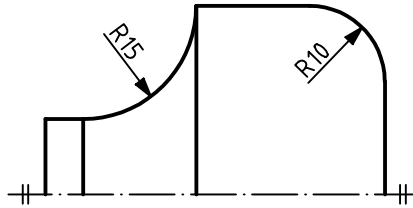

Figure 35

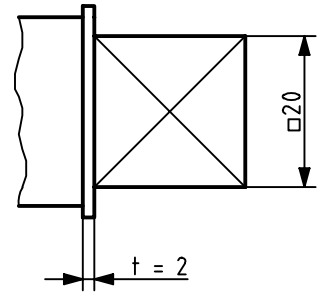

Figure 36

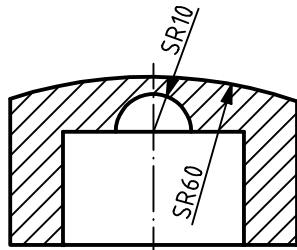

Figure 37

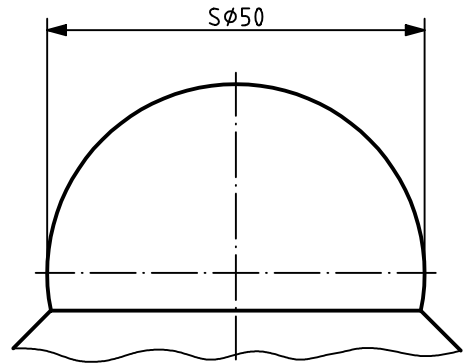

Figure 38

## 7.2 Diameters

The graphical symbol  $\varnothing$  shall precede the dimensional value (see Figures 34 and 39).

When a diameter can be illustrated by one arrowhead, the dimension line shall exceed the centre (see Figures 9 and 39).

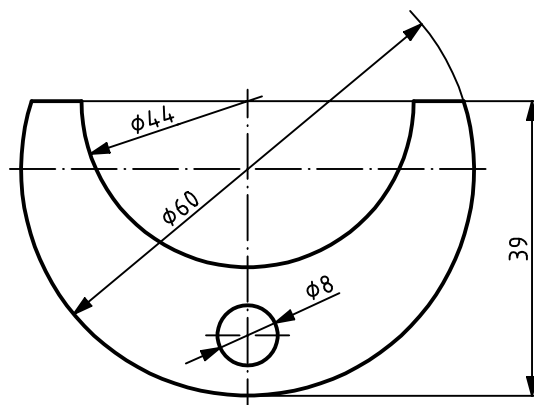

Figure 39

### 7.3 Radii

The letter symbol R shall precede the dimensional value of a radius (see Figure 35).

When dimensioning radii, only one terminator shall be used. It shall be indicated at the intersection of dimension line and arc (see Figure 40). In the case of an arrowhead as terminator and depending on the size of the radius on the drawing, the arrowhead may be either inside or outside the outline or extension line of the feature.

Where the centre of a radius falls outside the available space, the dimension line of the radius shall be either broken or interrupted perpendicular according to whether or not it is necessary to locate the centre (see Figure 40).

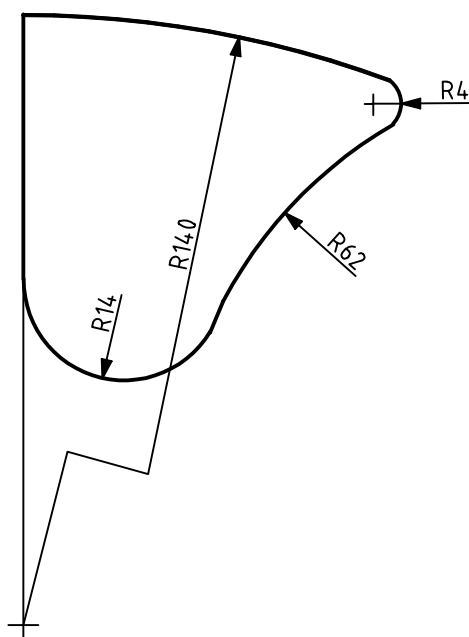

Figure 40

### 7.4 Spheres

If a spherical shape is illustrated, the symbol  $S\varnothing$  or SR shall precede the dimensional value (see Figures 37 and 38).

### 7.5 Arcs, chords and angles

The dimensioning of arcs, chords and angles shall be as shown in Figure 41. The graphical symbol  $\frown$  of an arc shall precede the dimensional value [see Figure A.1 h)].

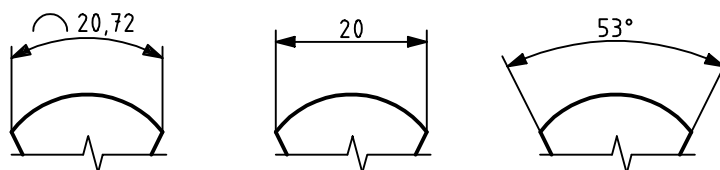

Figure 41



If the included angle of an arc is greater than  $90^\circ$ , the extension lines shall point to the centre of the arc. If the relation between the arc length and the dimensional value is ambiguous, it shall be indicated by a leader line, terminated by an arrowhead at the arc length to be dimensioned and by a point or a circle at the dimension line (see Figure 42). Connected dimensions of arcs, as well as linear or angular dimensions connected at an arc dimension, are indicated by an extension line (see Figure 42).

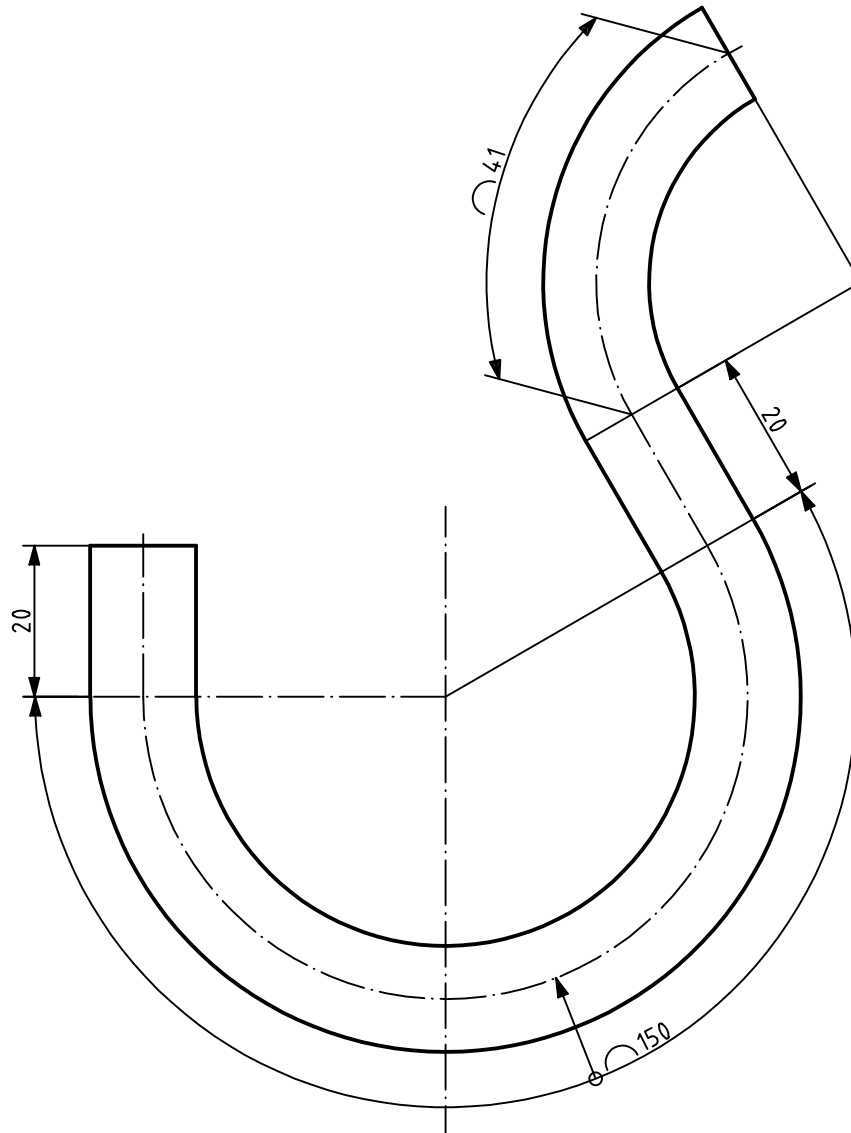

Figure 42

The rules given in Clause 6 are equally applicable to angular dimensions, except that the units of the angular basic dimension as well as the limit deviations shall always be indicated (see Figures 43 to 46). If the angular basic dimension or the angular limit deviation is expressed in either minutes of a degree or seconds of a minute of a degree, the value of the minute or second should be preceded by 0° or 0° 0', as applicable.

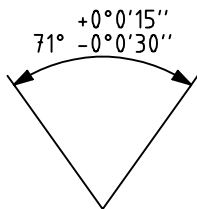

Figure 43

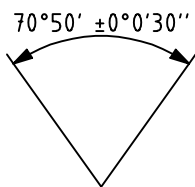

Figure 44

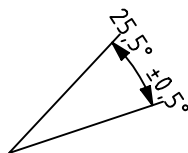

Figure 45

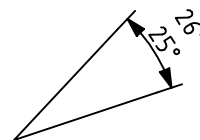

Figure 46

### 7.6 Squares

The graphical symbol □ shall precede the dimensional value if only one side of the square is dimensioned (see Figure 36).

### 7.7 Equally spaced and repeated features

Where features have the same spacing and are uniformly arranged, their dimensioning may be simplified as follows.

Linear spacings may be dimensioned as shown in Figure 47.

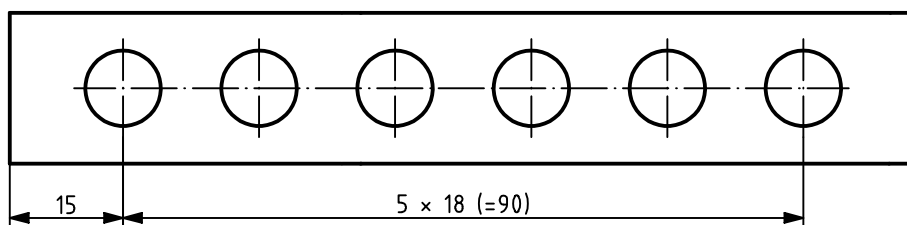

Figure 47

Repeated linear and angular spacings may be indicated with the number of spacings and their dimensional value or angle separated by the symbol "x". If there is any possibility of confusion between the length of the space and the number of spacings, one space shall be dimensioned as shown in Figure 48.

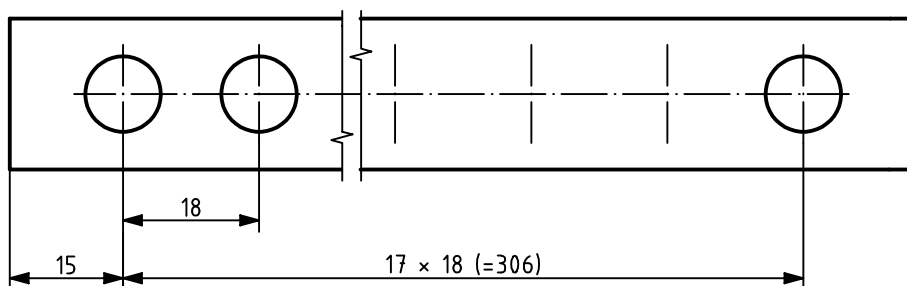

Figure 48

Angular spacings may be dimensioned as shown in Figure 49.

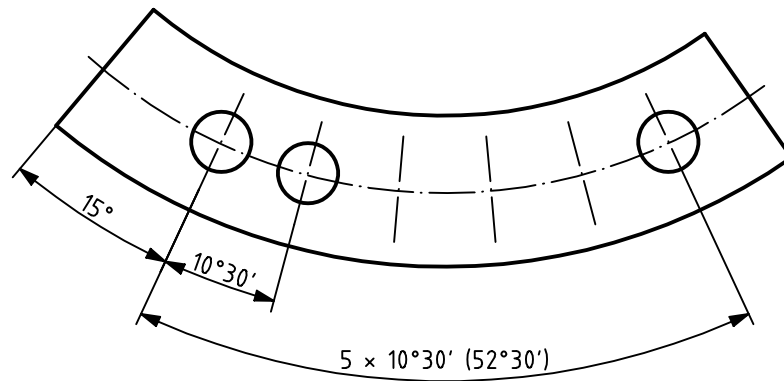

Figure 49

The angles of the spacings may be omitted where angles or spacings are self-evident and the indication does not lead to confusion (see Figure 50).

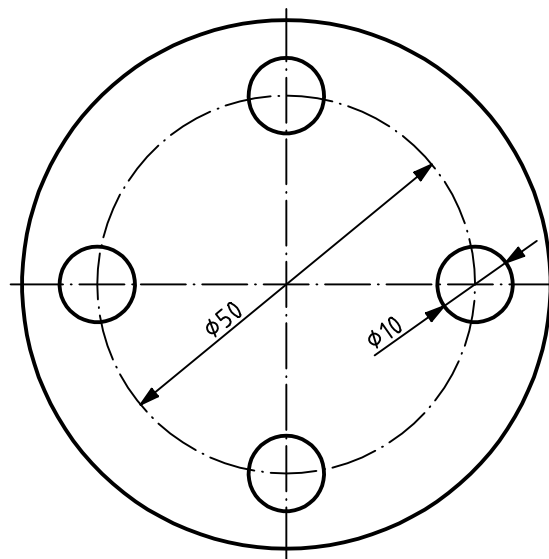

Figure 50

If the representation is unambiguous in showing that repeated features have the same dimensions, the dimension may be indicated once (see Figure 51).

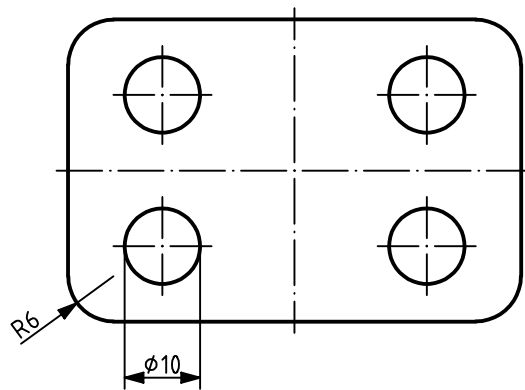

Figure 51

Circular spacings may be dimensioned by indicating the number of features (see Figure 52).

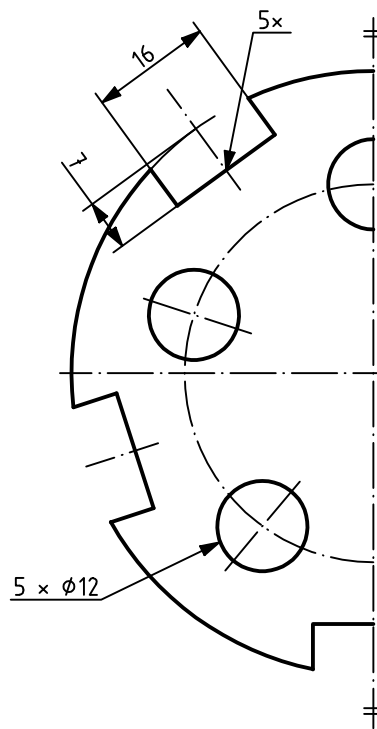

Figure 52

Features having the same dimensional value may be dimensioned by indicating the number of features and separating their dimensional value by the sign "x" (see Figure 53).

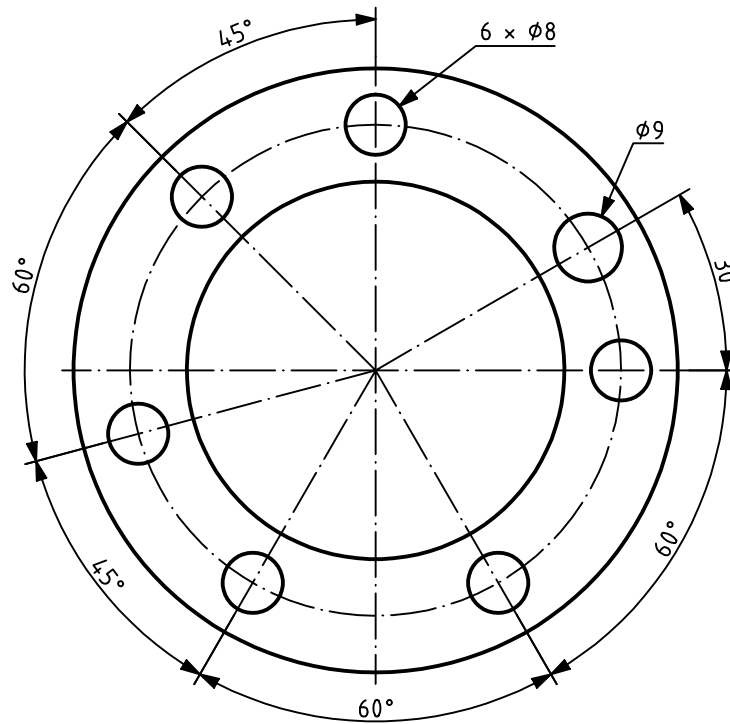

Figure 53

In order to avoid repeating the same dimensional value or to avoid long leader lines, reference letters may be used in connection with an explanatory table or note (see Figure 54). Leader lines may be omitted. If the representation is unambiguous, the indication of the number of features may be omitted.

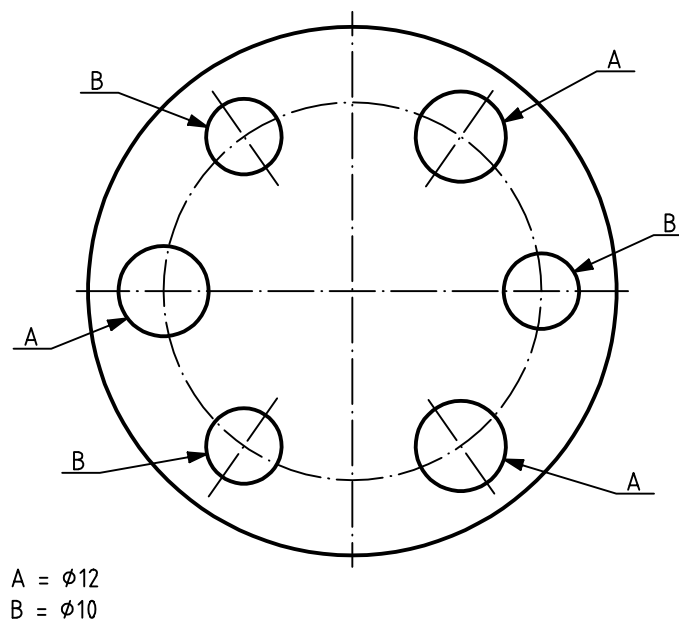

Figure 54

### 7.8 Symmetrical parts

The dimensions of symmetrical arranged features shall be indicated once only (see Figures 55 and 56).

Usually, the symmetry of features should not be dimensioned (see Figures 55 to 57).

In the case of half or quarter representations (see Figure 55), and if also required in the case of full representations, a symmetry symbol (see ISO 128-30) is added at the end of the axis of symmetry (see Figures 55 and 56).

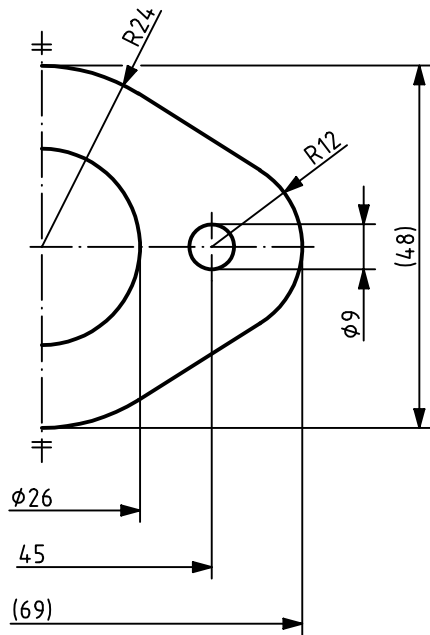

Figure 55

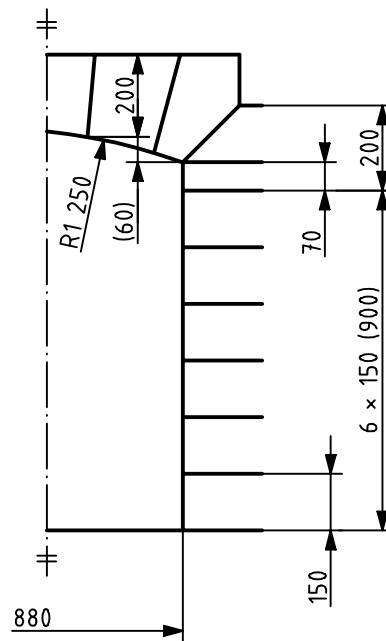

Figure 56

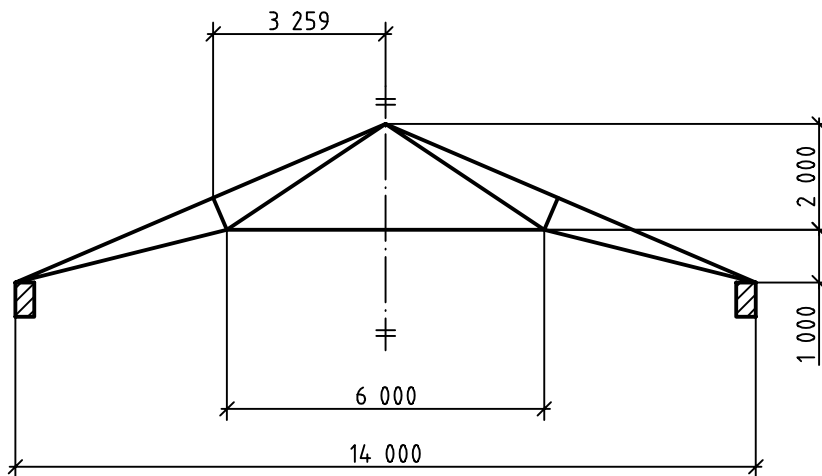

Figure 57

## 7.9 Indication of levels

Levels on vertical views, sections and cuts shall be indicated by an open 90° arrowhead connected with a vertical line and horizontal line above which the numerical value of level is placed (see Figure 58).

Levels for specified points on horizontal (planes) views and sections shall be indicated by a numerical value of the level placed above a line connected to the point indicated by "X" (see Figure 59).

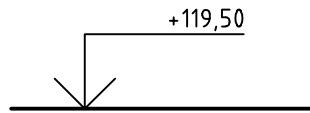

Figure 58

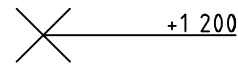

Figure 59

## 7.10 Dimensions of out-of-scale represented features

In exceptional cases, such as modifications, out-of-scale features shall be marked by the means of underlining the dimensional value.

## 7.11 Auxiliary dimensions

Auxiliary dimensions in drawings are for information only. They shall be given within parentheses, and shall never be toleranced (see Figures 55 and 56).

## 8 Arrangements of dimensions

### 8.1 General

Dimension lines shall be arranged as parallel, chain or running dimensioning or in combination.

### 8.2 Parallel dimensioning

The dimension lines shall be drawn parallel in one, two or three orthogonal directions or concentrically (see Figures 60 and 61).

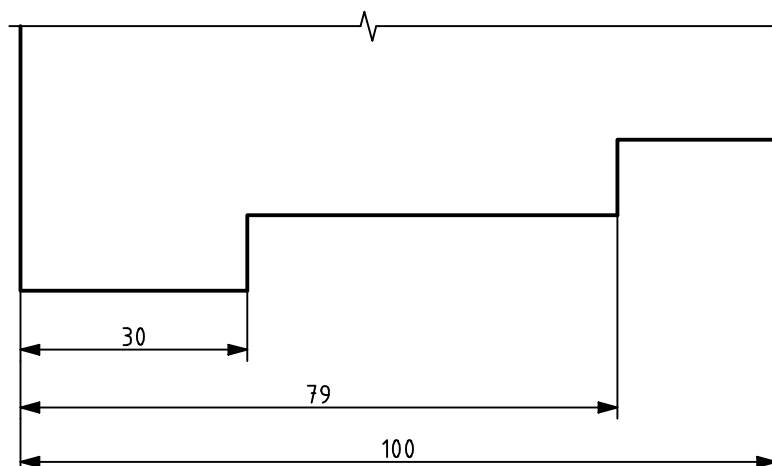

Figure 60

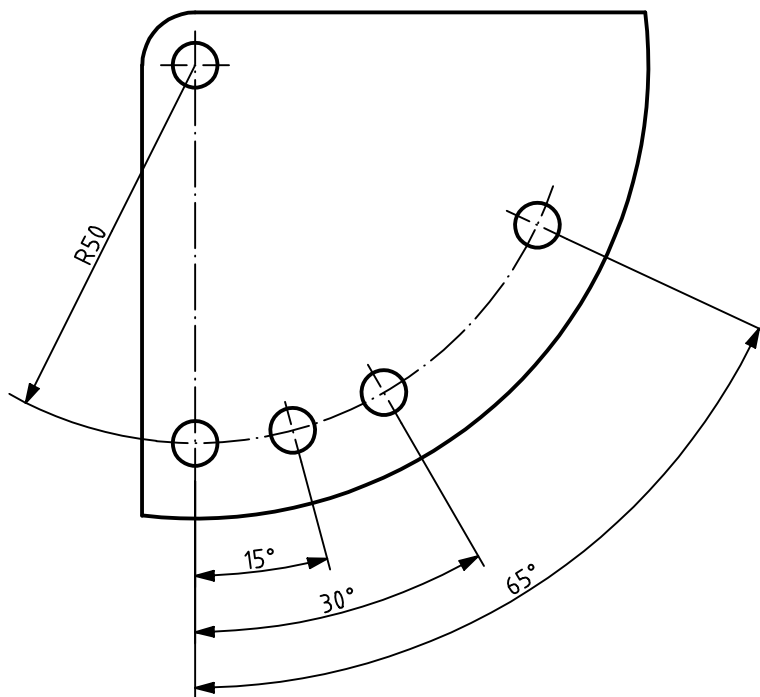

Figure 61

### 8.3 Running dimensioning

Running dimensioning may be used where there are space limitations or circumstances related to special needs in different branches of industry. The common origin shall be indicated as shown in Figures 62 to 64.

Dimensional values may be placed either

- near the terminator, in line with the corresponding extension line (see Figures 62 and 63), or
- near the terminator, above and clear of the dimension line (see Figure 64).

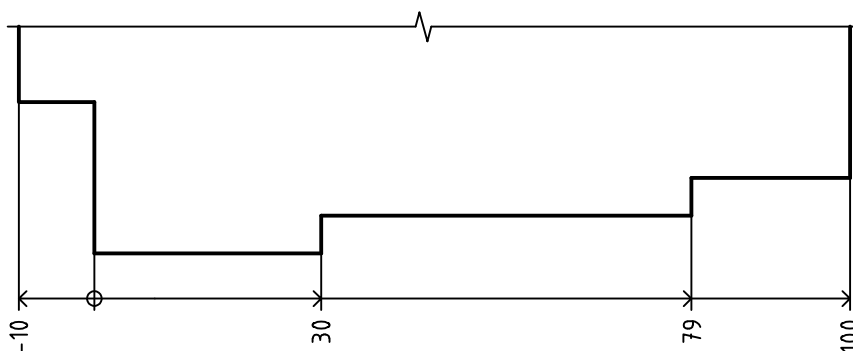

Figure 62



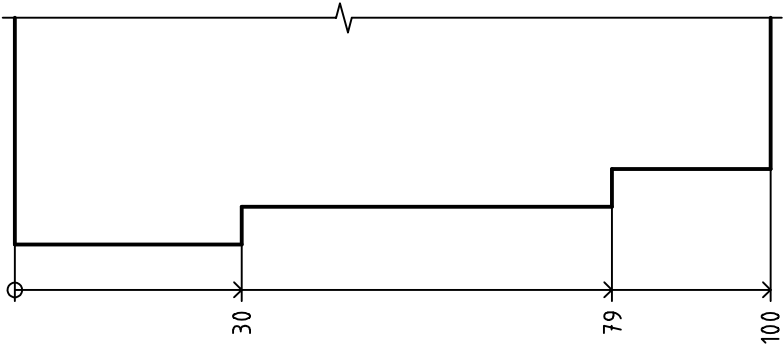

Figure 63

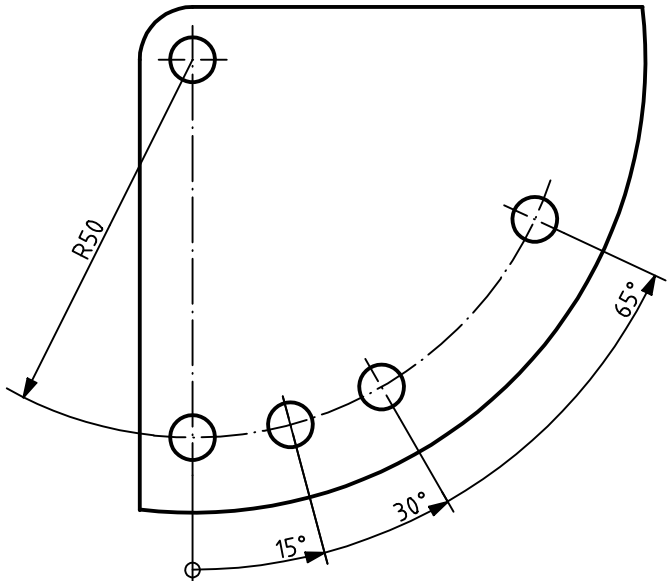

Figure 64

8.4 Chain dimensioning

Using chain dimensioning, chains of single dimensions shall be arranged in a row (see Figure 65).

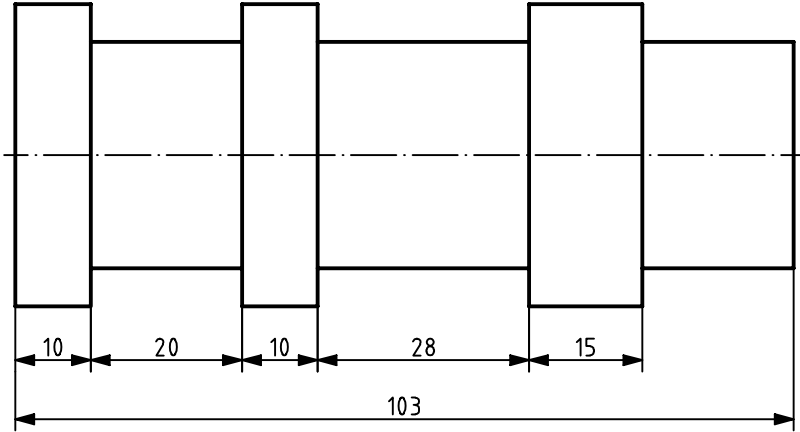

Figure 65

### 8.5 Coordinate dimensioning

Cartesian coordinates are defined starting from the origin by linear dimensions in orthogonal directions (see Figures 66 and 67). The values of the coordinates shall appear either adjacent to each point or in tabular form. Neither dimension lines nor extension lines are drawn.

NOTE In construction engineering, "X" and "Y" axes can be used in various ways to comply with national standards. Also, for three-dimensional systems in the construction field, the height, often designated "Z", might not have the same common origin as the "X" and "Y" axes.

Polar coordinates are defined starting from the origin by a radius and an angle. They shall always be positive, and are indicated anticlockwise relative to the polar axis (see Figure 68).

The positive and negative directions of the coordinate axes are shown in Figure 67. The dimensional values indicated in the negative directions shall have negative signs (see ISO 6412-2).

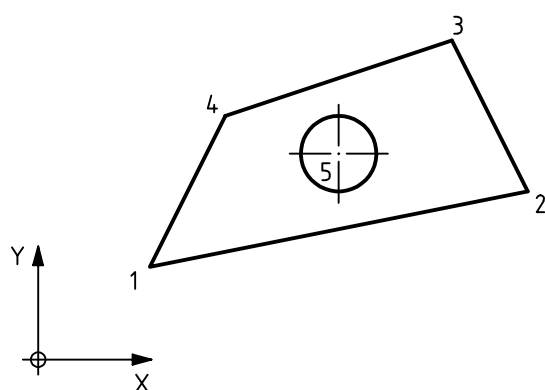

Position	X	Y	d
1	10	10	—
2	60	20	—
3	50	40	—
4	20	30	—
5	35	25	∅10

Figure 66

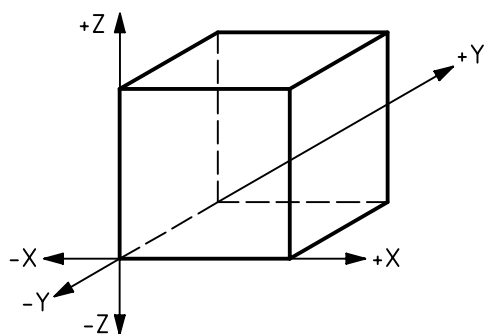

Figure 67

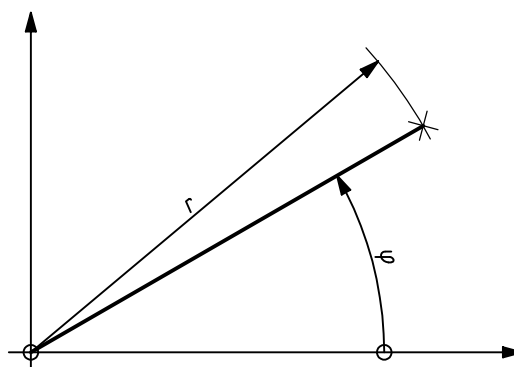

Figure 68

The origin of the coordinate system may be at the corner on a feature or outside the drawing (see Figures 66 and 69).

The coordinate values may be indicated directly near their coordinates (see Figure 69).

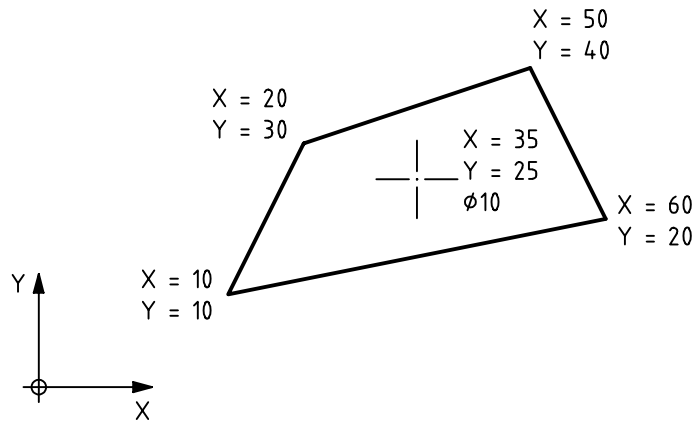
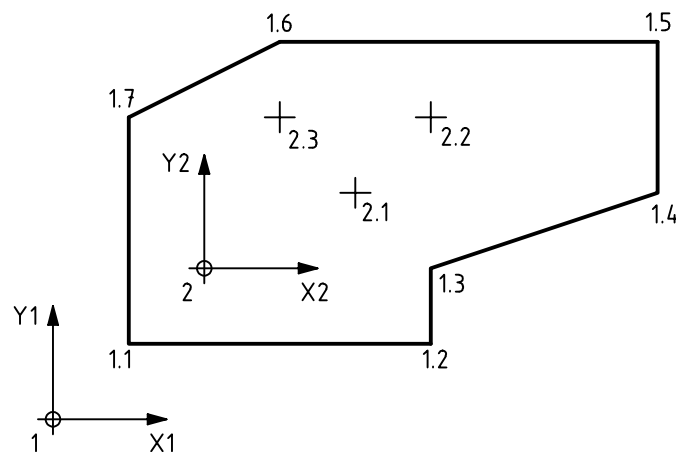

Figure 69

The main coordinate system may have subsystems. If this is the case, the origin of the coordinate systems and the specific positions within the coordinate systems shall be numbered continuously by arabic numbers. A point shall be used as a separation symbol (see Figure 70).



Coordinate origin	Position	X1, X2	Y1, Y2	$d_1$	$d_2$
1	1	0	0	—	—
1	1.1	10	10	—	—
1	1.2	50	10	—	—
1	1.3	50	20	—	—
1	1.4	80	30	—	—
1	1.5	80	50	—	—
1	1.6	30	50	—	—
1	1.7	10	40	—	—
1	2	20	20	∅10	—
2	2.1	20	10	∅5	—
2	2.2	30	20	—	∅10
2	2.3	10	20	∅5	—

Figure 70

### 8.6 Combined dimensioning

Two or more methods of dimensioning may be combined on a drawing.

Figure 71 shows an example of running dimensioning in combination with single dimensions.

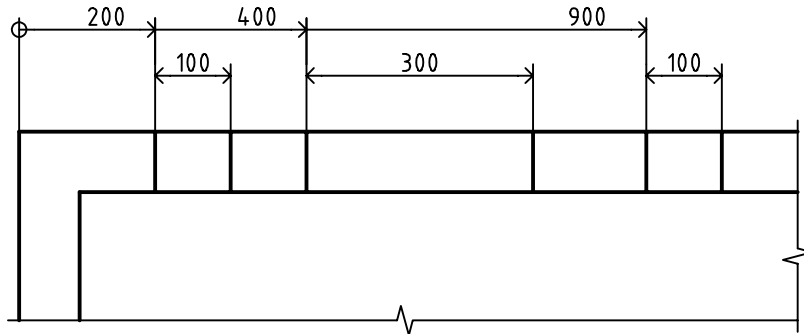

Figure 71

Figure 72 shows an example of parallel dimensioning in combination with running dimensioning.

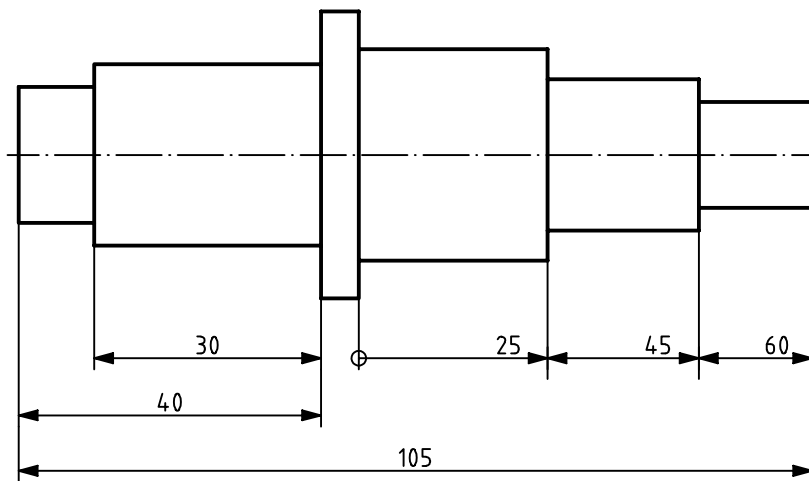
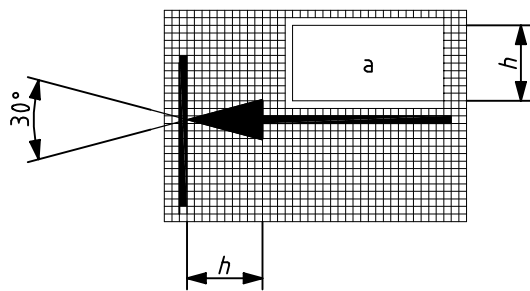

Figure 72

## Annex A (normative)

### Relations and dimensions of graphical symbols

In order to harmonize the sizes of the symbols specified in this International Standard with those of the other inscriptions on the drawing (dimensions, letters, tolerances), the rules, which are in accordance with ISO/IEC 81714-1, given in Figure A.1, shall be observed. The letter "a" indicates the area for lettering and the letter  $h$  the height of lettering (represented as lettering B vertical according to ISO 3098-0). Further graphical symbols are given in ISO 3098-5.



a) Arrowhead, closed and filled

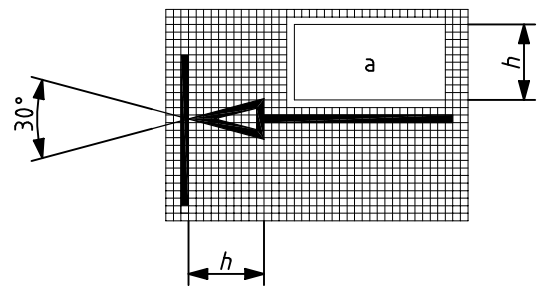

b) Arrowhead, closed

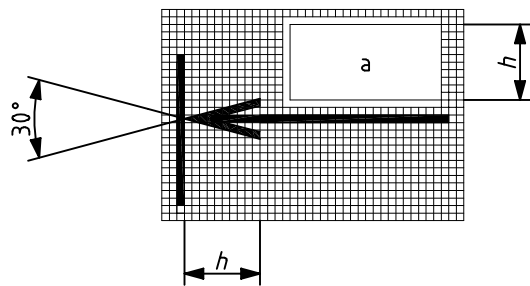

c) Arrowhead, open

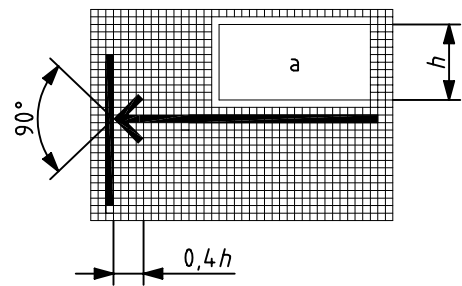

d) Arrowhead, open, included angle 90°

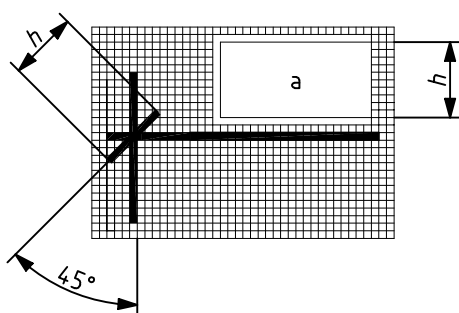

e) Oblique stroke

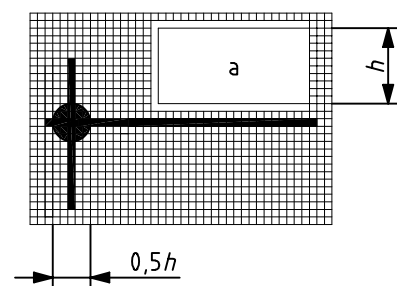

f) Point

Figure A.1

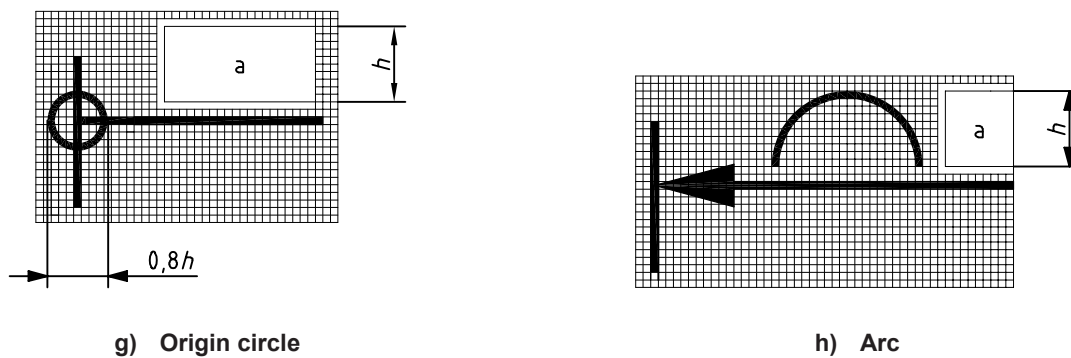

Figure A.1 (continued)

Table A.1 — Examples of applications of graphical and letter symbols

Symbols and their representation	Meaning
$\varnothing 50$	Diameter 50
$\square 50$	Square 50
R50	Radius 50
S $\varnothing 50$	Spherical diameter 50
SR50	Spherical radius 50
$\frown 50$	Arc length 50
	Indication of level 12,25
<u>50</u>	Out-of-scale 50
(50)	Auxiliary dimension 50
t = 5	Thickness 5
	Symbol of symmetry

## Bibliography

- [1] ISO 286-1:1988, *ISO system of limits and fits — Part 1: Bases of tolerances, deviations and fits*
- [2] ISO 1101:1983, *Technical drawings — Geometric tolerancing — Tolerancing of form, orientation, location and run-out — Generalities, definitions, symbols, indications on drawings*
- [3] ISO/R 1938-1:1971, *ISO system of limits and fits — Part 1: Inspection of plain workpieces*
- [4] ISO 2768-1:1989, *General tolerances — Part 1: Tolerances for linear and angular dimensions without individual tolerance indications*
- [5] ISO 2768-2:1989, *General tolerances — Part 2: Geometrical tolerances for features without individual tolerance indications*
- [6] ISO 3040:1990, *Technical drawings — Dimensioning and tolerancing — Cones*
- [7] ISO 3898:1997, *Bases for design of structures — Notations — General symbols*
- [8] ISO 5457:1999, *Technical product documentation — Sizes and layout of drawings sheets*
- [9] ISO 6433:1981, *Technical drawings — Item references*
- [10] ISO 10209-1:1992, *Technical product documentation — Vocabulary — Part 1: Terms relating to technical drawings: general and types of drawings*
- [11] ISO 13715:2000, *Technical drawings — Edges of undefined shape — Vocabulary and indications on drawings*
- [12] ISO/TR 14638:1995, *Geometrical product specification (GPS) — Masterplan*
- [13] ISO 14660-1:1999, *Geometrical product specification (GPS) — Geometrical features — Part 1: General terms and definitions*

---

---

## BSI — British Standards Institution

BSI is the independent national body responsible for preparing British Standards. It presents the UK view on standards in Europe and at the international level. It is incorporated by Royal Charter.

### Revisions

British Standards are updated by amendment or revision. Users of British Standards should make sure that they possess the latest amendments or editions.

It is the constant aim of BSI to improve the quality of our products and services. We would be grateful if anyone finding an inaccuracy or ambiguity while using this British Standard would inform the Secretary of the technical committee responsible, the identity of which can be found on the inside front cover.  
Tel: +44 (0)20 8996 9000. Fax: +44 (0)20 8996 7400.

BSI offers members an individual updating service called PLUS which ensures that subscribers automatically receive the latest editions of standards.

### Buying standards

Orders for all BSI, international and foreign standards publications should be addressed to Customer Services. Tel: +44 (0)20 8996 9001.  
Fax: +44 (0)20 8996 7001. Email: [orders@bsi-global.com](mailto:orders@bsi-global.com). Standards are also available from the BSI website at <http://www.bsi-global.com>.

In response to orders for international standards, it is BSI policy to supply the BSI implementation of those that have been published as British Standards, unless otherwise requested.

### Information on standards

BSI provides a wide range of information on national, European and international standards through its Library and its Technical Help to Exporters Service. Various BSI electronic information services are also available which give details on all its products and services. Contact the Information Centre.  
Tel: +44 (0)20 8996 7111. Fax: +44 (0)20 8996 7048. Email: [info@bsi-global.com](mailto:info@bsi-global.com).

Subscribing members of BSI are kept up to date with standards developments and receive substantial discounts on the purchase price of standards. For details of these and other benefits contact Membership Administration.  
Tel: +44 (0)20 8996 7002. Fax: +44 (0)20 8996 7001.  
Email: [membership@bsi-global.com](mailto:membership@bsi-global.com).

Information regarding online access to British Standards via British Standards Online can be found at <http://www.bsi-global.com/bsonline>.

Further information about BSI is available on the BSI website at <http://www.bsi-global.com>.

### Copyright

Copyright subsists in all BSI publications. BSI also holds the copyright, in the UK, of the publications of the international standardization bodies. Except as permitted under the Copyright, Designs and Patents Act 1988 no extract may be reproduced, stored in a retrieval system or transmitted in any form or by any means – electronic, photocopying, recording or otherwise – without prior written permission from BSI.

This does not preclude the free use, in the course of implementing the standard, of necessary details such as symbols, and size, type or grade designations. If these details are to be used for any other purpose than implementation then the prior written permission of BSI must be obtained.

Details and advice can be obtained from the Copyright & Licensing Manager.  
Tel: +44 (0)20 8996 7070. Fax: +44 (0)20 8996 7553.  
Email: [copyright@bsi-global.com](mailto:copyright@bsi-global.com).