

# Technical drawings — General principles of presentation

## Part 30: Basic conventions for views

ICS 01.100.01

## National foreword

This British Standard reproduces verbatim ISO 128-30:2001 and implements it as the UK national standard. It partially supersedes BS ISO 128:1982 which will be withdrawn on completion of the overall revision process for ISO 128:1982.

The UK participation in its preparation was entrusted to Technical Committee TDW/4, Engineering drawing, Metrology, precision measurement and all related documentation, which has the responsibility to:

- aid enquirers to understand the text;
- present to the responsible international/European committee any enquiries on the interpretation, or proposals for change, and keep the UK interests informed;
- monitor related international and European developments and promulgate them in the UK.

A list of organizations represented on this committee can be obtained on request to its secretary.

### Cross-references

The British Standards which implement international publications referred to in this document may be found in the BSI Standards Catalogue under the section entitled “International Standards Correspondence Index”, or by using the “Find” facility of the BSI Standards Electronic Catalogue.

A British Standard does not purport to include all the necessary provisions of a contract. Users of British Standards are responsible for their correct application.

**Compliance with a British Standard does not of itself confer immunity from legal obligations.**

This British Standard, having been prepared under the direction of the Consumer Products and Services Sector committee, was published under the authority of the Standards Committee and comes into effect on 15 July 2001

### Summary of pages

This document comprises a front cover, an inside front cover, the ISO title page, pages i to iv, pages 1 to 11 and a back cover.

The BSI copyright date displayed in this document indicates when the document was last issued.

### Amendments issued since publication

Amd. No.	Date	Comments

---

---

**Technical drawings — General principles of  
presentation —**

Part 30:  
**Basic conventions for views**

*Dessins techniques — Principes généraux de représentation —*

*Partie 30: Conventions de base pour les vues*





## Foreword

ISO (the International Organization for Standardization) is a worldwide federation of national standards bodies (ISO member bodies). The work of preparing International Standards is normally carried out through ISO technical committees. Each member body interested in a subject for which a technical committee has been established has the right to be represented on that committee. International organizations, governmental and non-governmental, in liaison with ISO, also take part in the work. ISO collaborates closely with the International Electrotechnical Commission (IEC) on all matters of electrotechnical standardization.

International Standards are drafted in accordance with the rules given in the ISO/IEC Directives, Part 3.

Draft International Standards adopted by the technical committees are circulated to the member bodies for voting. Publication as an International Standard requires approval by at least 75 % of the member bodies casting a vote.

Attention is drawn to the possibility that some of the elements of this part of ISO 128 may be the subject of patent rights. ISO shall not be held responsible for identifying any or all such patent rights.

International Standard ISO 128-30 was prepared by Technical Committee ISO/TC 10, *Technical product documentation*, Subcommittee SC 1, *Basic conventions*.

This first edition is based on ISO 128:1982, clause 2 of which it cancels and replaces.

ISO 128 consists of the following parts, under the general title *Technical drawings — General principles of presentation*:

- *Part 20: Basic conventions for lines*
- *Part 21: Preparation of lines by CAD systems*
- *Part 22: Basic conventions and applications for leader lines and reference lines*
- *Part 23: Lines on construction drawings*
- *Part 24: Lines on mechanical engineering drawings*
- *Part 25: Lines on shipbuilding drawings*
- *Part 30: Basic conventions for views*
- *Part 34: Views on mechanical engineering drawings*
- *Part 40: Basic conventions for cuts and sections*
- *Part 44: Sections on mechanical engineering drawings*
- *Part 50: Basic conventions for representing areas on cuts and sections*

The following part is under preparation: *Part 1: Introduction and index*.

Annexes A ,B and C form a normative part of this part of ISO 128.

## Introduction

According to the replaced clause 2 of ISO 128:1982 three different methods of presenting views are allowed. In this part of ISO 128, the method of using reference arrows has been selected as the preferred one. The first angle projection method (formerly referred to as method E) and the third angle projection method (formerly referred to as method A) are still to be regarded as normative. Annexes A and B of this part of ISO 128 give basic information on the first and third angle projection methods; ISO 5456-2 specifies the rules in detail.

# Technical drawings — General principles of presentation —

## Part 30: Basic conventions for views

### 1 Scope

This part of ISO 128 specifies the general principles for presenting views, applicable to all kinds of technical drawings (mechanical, electrical, architectural, civil engineering, etc.), following the orthographic projection methods specified in ISO 5456-2.

Attention has also been given in this part of ISO 128 to the requirements of reproduction, including microcopying in accordance with ISO 6428.

### 2 Normative references

The following normative documents contain provisions which, through reference in this text, constitute provisions of this part of ISO 128. For dated references, subsequent amendments to, or revisions of, any of these publications do not apply. However, parties to agreements based on this part of ISO 128 are encouraged to investigate the possibility of applying the most recent editions of the normative documents indicated below. For undated references, the latest edition of the normative document referred to applies. Members of ISO and IEC maintain registers of currently valid International Standards.

ISO 128-24:1999, *Technical drawings — General principles of presentation — Part 24: Lines on mechanical engineering drawings.*

ISO 3098-0, *Technical product documentation — Lettering — Part 0: General requirements.*

ISO 5456-2, *Technical drawings — Projection methods — Part 2: Orthographic representations.*

ISO 6428, *Technical drawings — Requirements for microcopying.*

ISO 10209-1, *Technical product documentation — Vocabulary — Part 1: Terms relating to technical drawings: general and types of drawings.*

ISO 10209-2, *Technical product documentation — Vocabulary — Part 2: Terms relating to projection methods.*

ISO 81714-1, *Design of graphical symbols for use in the technical documentation of products — Part 1: Basic rules.*

### 3 Terms and definitions

For the purposes of this part of ISO 128, the terms and definitions given in ISO 10209-1 and ISO 10209-2 apply.

### 4 General

The most informative view of an object shall be used as the front or principal figure, taking into consideration, for example, its functioning position, position of manufacturing or mounting.

Each view, with the exception of the front or principal figure (view, plan, principal figure), shall be given clear identification with a capital letter, repeated near the reference arrow needed to indicate the direction of viewing for the

relevant view. Whatever the direction of viewing, the capital letter shall always be positioned in normal relation to the direction of reading, and be indicated either above or on the right side of the reference arrow.

The reference arrow is defined in annex C (including the arc arrow, see clause 7), as is the lettering height of the identification.

The designated views may be located irrespective of the principal figure. The capital letters identifying the referenced views shall be placed immediately above the relevant views (see Figure 1).

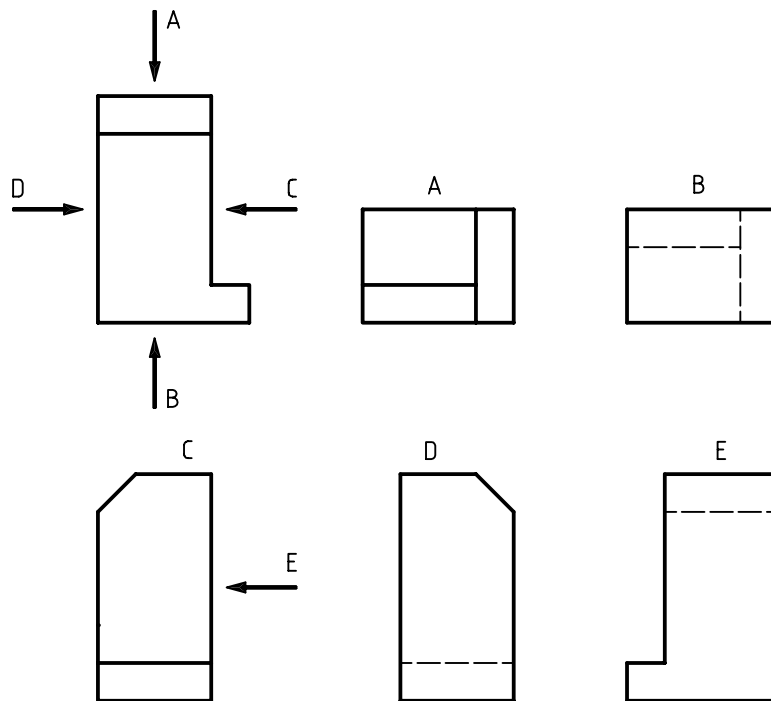

Figure 1 — Identification of referenced views

## 5 Choice of views

When views (including cuts and sections) are needed, these shall be selected according to the following principles:

- limit the number of views (and cuts and sections) to the minimum necessary but sufficient to fully delineate the object without ambiguity;
- avoid the need for hidden outlines and edges;
- avoid unnecessary repetition of a detail.



## 6 Partial views

### 6.1 General

Features needing specific illustration, but not meriting a full view, may be illustrated using a partial view limited by a continuous narrow line with zigzags of type 01.1.19 according to ISO 128-24:1999 (see Figure 2).

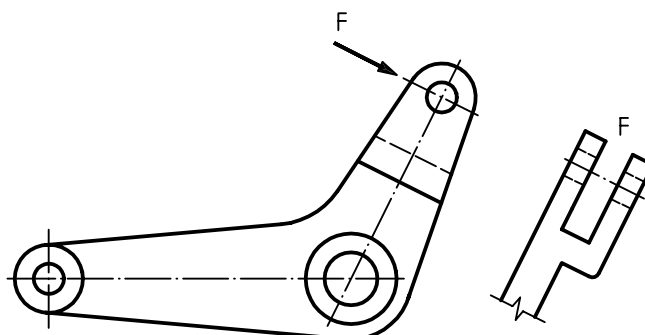
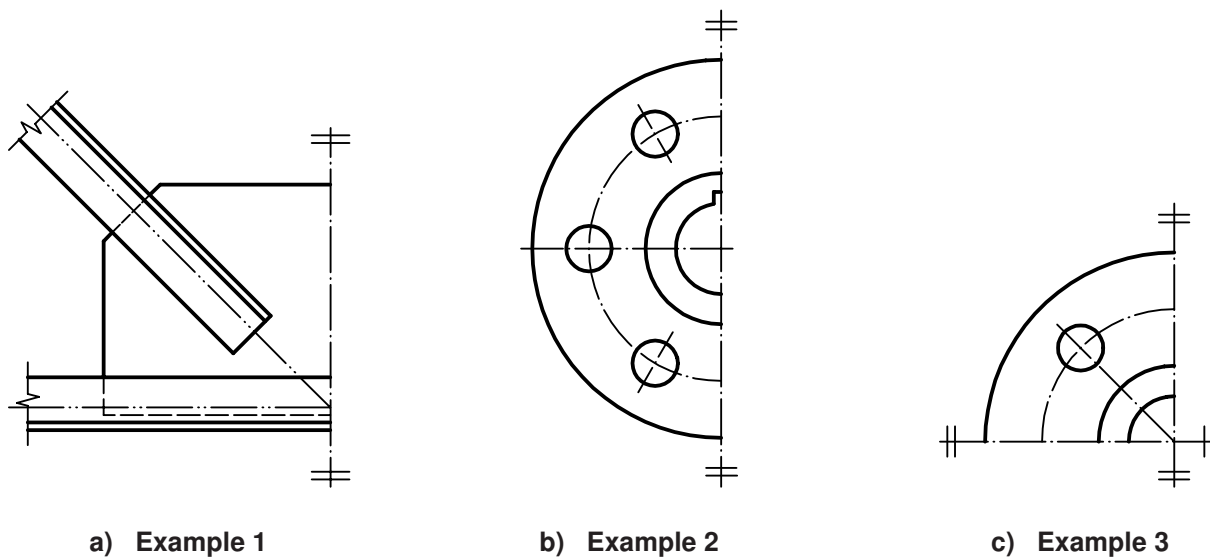

Figure 2 — Partial view

### 6.2 Partial view of symmetrical parts

To save time and space, symmetrical objects may be drawn as a fraction of the whole [see Figure 3 a), b) and c)].

The line of symmetry is identified at each of its ends by two narrow short parallel lines drawn at right angles to it [see Figure 3 a), b) and c)]. The graphical symbol for symmetry shall be drawn in accordance with clause C.4.



a) Example 1

b) Example 2

c) Example 3

Figure 3 — Partial view of symmetrical parts

## 7 Special positions of view

When necessary, it is permitted to show the view in another position than that indicated by the reference arrow.

The fact that the view is shown in another position should be clarified by an arc arrow showing the direction of rotation according to Figure 4 a) and b). The angle of rotation of the view after the capital letter may be indicated. If used, the sequence shall be:

“view identification — arc arrow — angle of rotation”

The arc arrow shall be drawn in accordance with clause C.3.

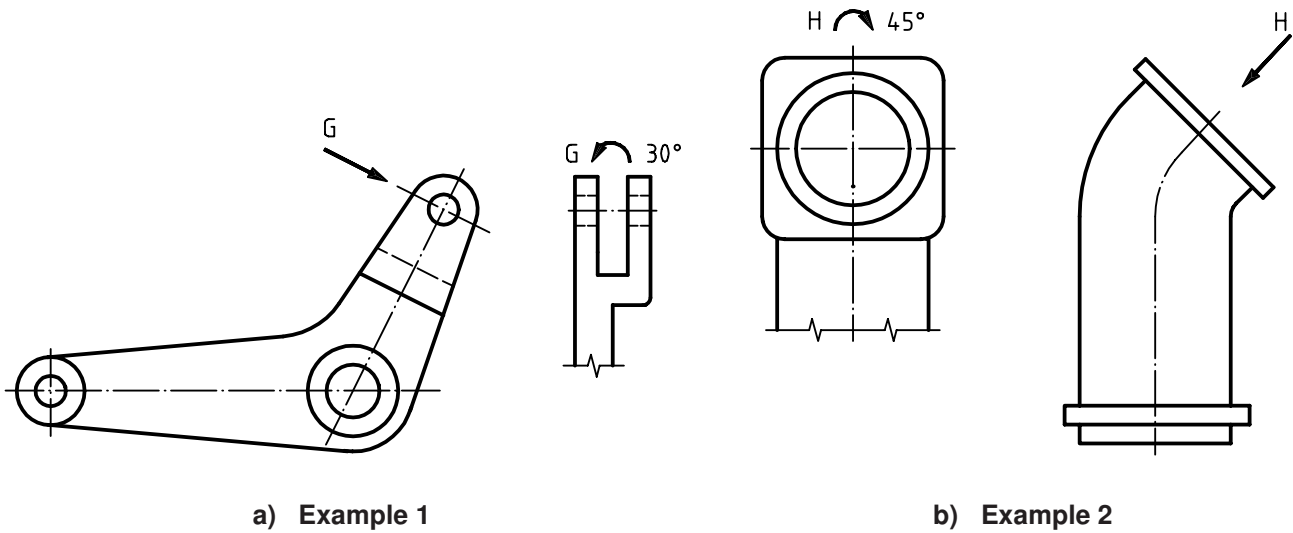

Figure 4 — Special view positions

## Annex A (normative)

### First angle projection method

#### A.1 General

The first angle projection method is to be regarded as a requirement of this part of ISO 128. A more detailed description of the first angle projection method is to be found in ISO 5456-2.

#### A.2 First angle projection method

With reference to the front view, (a), the other views are arranged as follows (see Figure A.1):

- the view from above, (b), is placed underneath;
- the view from below, (e), is placed above;
- the view from the left, (c), is placed on the right;
- the view from the right, (d), is placed on the left;
- the view from the rear, (f), may be placed on the left or right, as convenient.

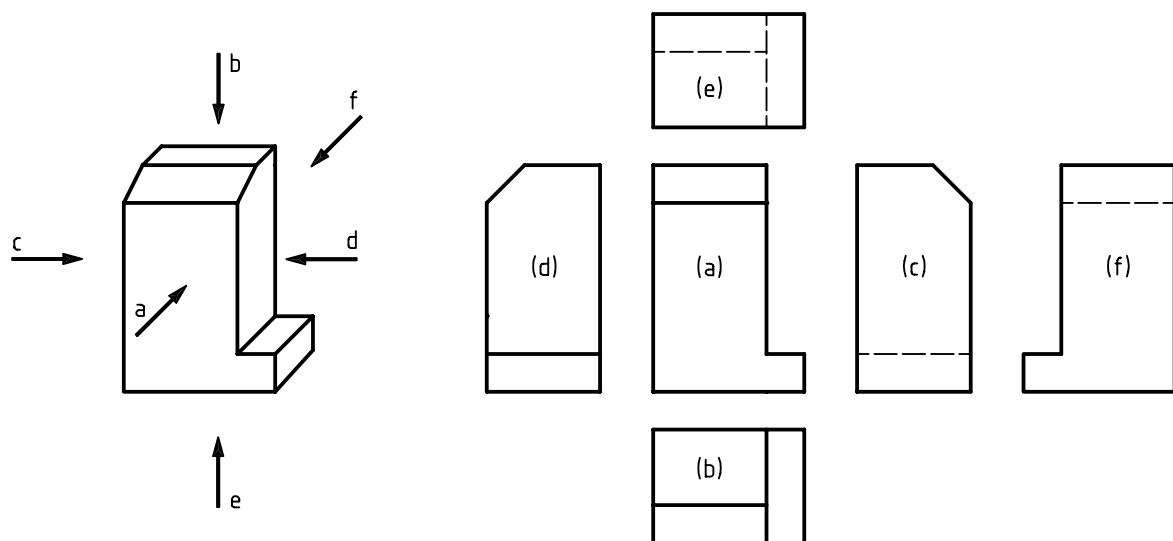

Figure A.1 — First angle projection method

### A.3 Graphical symbol

The graphical symbol for the first angle projection method is shown in Figure A.2. The proportions and dimensions of this graphical symbol are specified in ISO 5456-2.

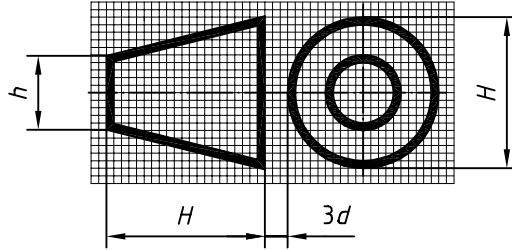

Figure A.2 — Graphical symbol

## Annex B (normative)

### Third angle projection method

#### B.1 General

The third angle projection method is to be regarded as a requirement of this part of ISO 128. A more detailed description of the third angle projection method is to be found in ISO 5456-2.

#### B.2 Third angle projection method

With reference to the front view, (a), the other views are arranged as follows (see Figure B.1):

- the view from above, (b), is placed above;
- the view from below, (e), is placed underneath;
- the view from the left, (c), is placed on the left;
- the view from the right, (d), is placed on the right;
- the view from the rear, (f), may be placed on the left or right, as convenient.

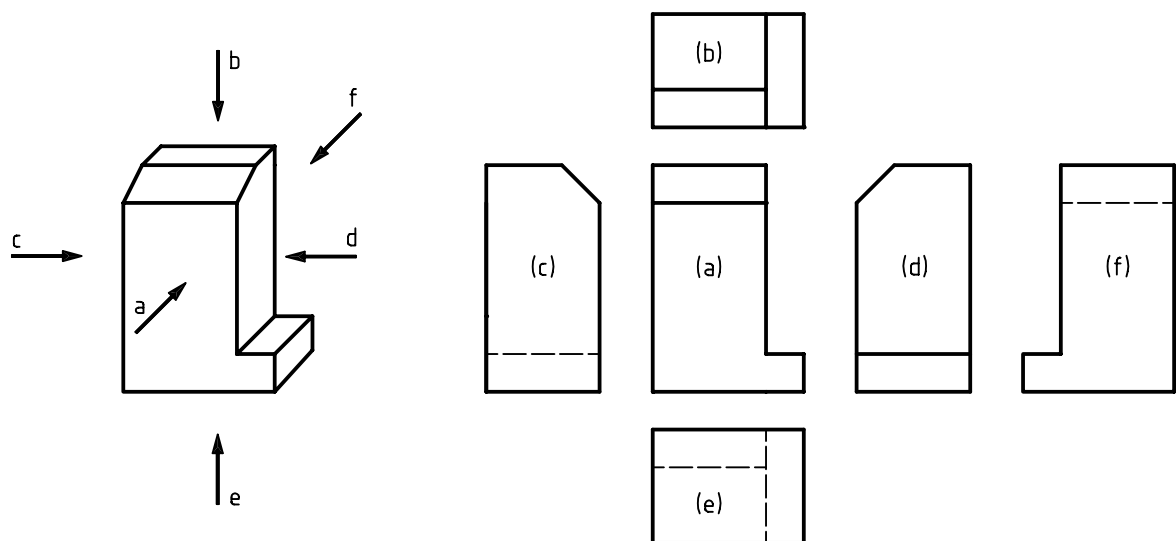

Figure B.1 — Third angle projection method

### B.3 Graphical symbol

The graphical symbol for the third angle projection method is shown in Figure B.2. The proportions and dimensions of this graphical symbol are specified in ISO 5456-2.

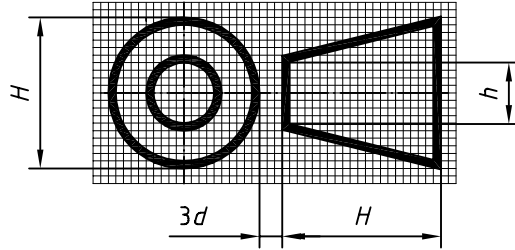

Figure B.2 — Graphical symbol

## Annex C (normative)

### Graphical symbols

#### C.1 General

In order to harmonize the sizes of the graphical symbols specified in this part of ISO 128 with those of the other inscriptions on the drawing (dimensions, tolerances, etc.), the rules given in ISO 81714-1 shall apply.

The view identification lettering height,  $h$ , shall be larger than the normal lettering on the technical drawing by a factor of  $\sqrt{2}$ .

Within Figures C.1, C.2 and C.3, lettering type B, vertical, according to ISO 3098-0, applies. Other lettering types are also permitted.

#### C.2 Reference arrow

See Figure C.1.

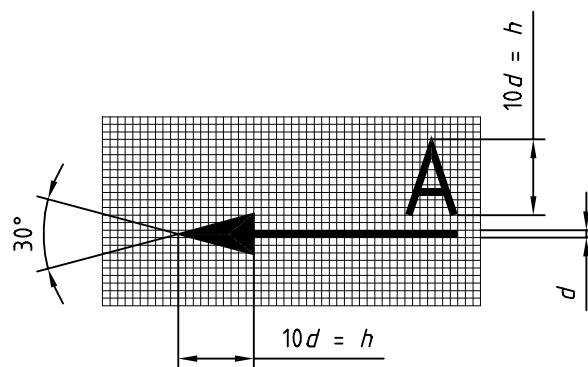

Figure C.1 — Graphical symbol for reference arrows

#### C.3 Arc arrow

See Figure C.2.

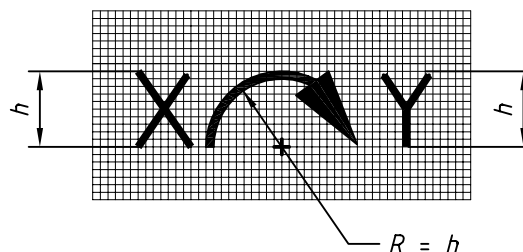
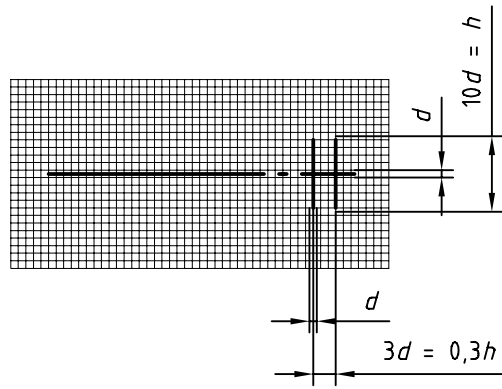

Figure C.2 — Graphical symbol for arc arrows

**C.4 Symmetry**

See Figure C.3.



**Figure C.3 — Graphical symbol for symmetry**



## Bibliography

- [1] ISO 128-20, *Technical drawings — General principles of presentation — Part 20: Basic conventions for lines.*

---

---

## BSI — British Standards Institution

BSI is the independent national body responsible for preparing British Standards. It presents the UK view on standards in Europe and at the international level. It is incorporated by Royal Charter.

### Revisions

British Standards are updated by amendment or revision. Users of British Standards should make sure that they possess the latest amendments or editions.

It is the constant aim of BSI to improve the quality of our products and services. We would be grateful if anyone finding an inaccuracy or ambiguity while using this British Standard would inform the Secretary of the technical committee responsible, the identity of which can be found on the inside front cover. Tel: 020 8996 9000. Fax: 020 8996 7400.

BSI offers members an individual updating service called PLUS which ensures that subscribers automatically receive the latest editions of standards.

### Buying standards

Orders for all BSI, international and foreign standards publications should be addressed to Customer Services. Tel: 020 8996 9001. Fax: 020 8996 7001. Standards are also available from the BSI website at <http://www.bsi-global.com>.

In response to orders for international standards, it is BSI policy to supply the BSI implementation of those that have been published as British Standards, unless otherwise requested.

### Information on standards

BSI provides a wide range of information on national, European and international standards through its Library and its Technical Help to Exporters Service. Various BSI electronic information services are also available which give details on all its products and services. Contact the Information Centre. Tel: 020 8996 7111. Fax: 020 8996 7048.

Subscribing members of BSI are kept up to date with standards developments and receive substantial discounts on the purchase price of standards. For details of these and other benefits contact Membership Administration. Tel: 020 8996 7002. Fax: 020 8996 7001. Further information about BSI is available on the BSI website at <http://www.bsi-global.com>.

### Copyright

Copyright subsists in all BSI publications. BSI also holds the copyright, in the UK, of the publications of the international standardization bodies. Except as permitted under the Copyright, Designs and Patents Act 1988 no extract may be reproduced, stored in a retrieval system or transmitted in any form or by any means – electronic, photocopying, recording or otherwise – without prior written permission from BSI.

This does not preclude the free use, in the course of implementing the standard, of necessary details such as symbols, and size, type or grade designations. If these details are to be used for any other purpose than implementation then the prior written permission of BSI must be obtained.

If permission is granted, the terms may include royalty payments or a licensing agreement. Details and advice can be obtained from the Copyright Manager. Tel: 020 8996 7070.