

BS ISO 104:2015



BSI Standards Publication

Rolling bearings — Thrust bearings — Boundary dimensions, general plan

bsi.

...making excellence a habit.™

National foreword

This British Standard is the UK implementation of ISO 104:2015. It supersedes BS ISO 104:2002 which is withdrawn.

The UK participation in its preparation was entrusted to Technical Committee MCE/7, Rolling bearings.

A list of organizations represented on this committee can be obtained on request to its secretary.

This publication does not purport to include all the necessary provisions of a contract. Users are responsible for its correct application.

© The British Standards Institution 2015.
Published by BSI Standards Limited 2015

ISBN 978 0 580 83503 2

ICS 21.100.20

Compliance with a British Standard cannot confer immunity from legal obligations.

This British Standard was published under the authority of the Standards Policy and Strategy Committee on 30 September 2015.

Amendments/corrigenda issued since publication

Date	Text affected
------	---------------

INTERNATIONAL
STANDARD

BS ISO 104:2015

ISO
104

Fourth edition
2015-09-15

**Rolling bearings — Thrust bearings —
Boundary dimensions, general plan**

Roulements — Butées — Dimensions d'encombrement, plan général



Reference number
ISO 104:2015(E)

© ISO 2015



COPYRIGHT PROTECTED DOCUMENT

© ISO 2015, Published in Switzerland

All rights reserved. Unless otherwise specified, no part of this publication may be reproduced or utilized otherwise in any form or by any means, electronic or mechanical, including photocopying, or posting on the internet or an intranet, without prior written permission. Permission can be requested from either ISO at the address below or ISO's member body in the country of the requester.

ISO copyright office
Ch. de Blandonnet 8 • CP 401
CH-1214 Vernier, Geneva, Switzerland
Tel. +41 22 749 01 11
Fax +41 22 749 09 47
copyright@iso.org
www.iso.org

Contents		Page
Foreword		iv
1 Scope		1
2 Normative references		1
3 Terms and definitions		1
4 Symbols		1
5 Boundary dimensions		3
5.1 General		3
5.2 Single-direction thrust bearings with flat back faces		3
5.3 Double-direction thrust bearings with flat back faces		16
Annex A (informative) Guidelines for the extension of this International Standard for single-direction thrust bearings		20
Bibliography		22

Foreword

ISO (the International Organization for Standardization) is a worldwide federation of national standards bodies (ISO member bodies). The work of preparing International Standards is normally carried out through ISO technical committees. Each member body interested in a subject for which a technical committee has been established has the right to be represented on that committee. International organizations, governmental and non-governmental, in liaison with ISO, also take part in the work. ISO collaborates closely with the International Electrotechnical Commission (IEC) on all matters of electrotechnical standardization.

The procedures used to develop this document and those intended for its further maintenance are described in the ISO/IEC Directives, Part 1. In particular the different approval criteria needed for the different types of ISO documents should be noted. This document was drafted in accordance with the editorial rules of the ISO/IEC Directives, Part 2 (see www.iso.org/directives).

Attention is drawn to the possibility that some of the elements of this document may be the subject of patent rights. ISO shall not be held responsible for identifying any or all such patent rights. Details of any patent rights identified during the development of the document will be in the Introduction and/or on the ISO list of patent declarations received (see www.iso.org/patents).

Any trade name used in this document is information given for the convenience of users and does not constitute an endorsement.

For an explanation on the meaning of ISO specific terms and expressions related to conformity assessment, as well as information about ISO's adherence to the WTO principles in the Technical Barriers to Trade (TBT) see the following URL: [Foreword - Supplementary information](#)

The committee responsible for this document is ISO/TC 4, *Rolling bearings*.

This fourth edition cancels and replaces the third edition (ISO 104:2002), which has been technically revised with changes that are editorial and concern mainly on terminology and format.

Rolling bearings — Thrust bearings — Boundary dimensions, general plan

1 Scope

This International Standard specifies preferred boundary dimensions for single-direction and double-direction thrust bearings with flat back faces.

In addition, it gives the minimum bore diameters of housing washers and maximum outside diameters of shaft washers of bearings in dimension series 11, 12, 13, 14, 22, 23 and 24.

Guidelines for the extension of this International Standard for single-direction thrust bearings are given in [Annex A](#).

NOTE Boundary dimensions for aligning thrust bearings (none flat back faces) and aligning seat washers are given in ISO 20516.^[2]

2 Normative references

The following documents, in whole or in part, are normatively referenced in this document and are indispensable for its application. For dated references, only the edition cited applies. For undated references, the latest edition of the referenced document (including any amendments) applies.

ISO 582, *Rolling bearings — Chamfer dimensions — Maximum values*

ISO 5593, *Rolling bearings — Vocabulary*

ISO 15241, *Rolling bearings — Symbols for physical quantities*

3 Terms and definitions

For the purposes of this document, the terms and definitions given in ISO 5593 and the following apply.

3.1

single-direction thrust bearing with flat back faces

thrust rolling bearing with flat back faces intended to support axial load in one direction only

3.2

double-direction thrust bearing with flat back faces

thrust rolling bearing with flat back faces intended to support axial load in both directions

3.3

central shaft washer

central washer which is intended to be mounted on a shaft

[SOURCE: ISO 20516:2007, 3.5]

4 Symbols

For the purposes of this International Standard, the symbols given in ISO 15241 and the following apply.

The symbols shown in [Figures 1](#) and [2](#) and the values given in [Tables 1](#) to [9](#) denote nominal dimensions, unless specified otherwise.

B	height of central shaft washer
D	outside diameter of housing washer
D_1	bore diameter of housing washer
$D_{1s \text{ min}}$	smallest single bore diameter of housing washer
d	bore diameter of shaft washer, single-direction thrust bearing with flat back faces
d_1	outside diameter of shaft washer, single-direction thrust bearing with flat back faces
$d_{1s \text{ max}}$	largest single outside diameter of shaft washer
d_2	bore diameter of central shaft washer, double-direction thrust bearing with flat back faces
d_3	outside diameter of central shaft washer, double-direction thrust bearing with flat back faces
$d_{3s \text{ max}}$	largest single outside diameter of central shaft washer
r	back face chamfer dimension of shaft washer and housing washer
$r_{s \text{ min}}$	smallest single back face chamfer dimension of shaft washer and housing washer
r_1	face chamfer dimension of central shaft washer
$r_{1s \text{ min}}$	smallest single face chamfer dimension of central shaft washer
T	bearing height, single-direction thrust bearing with flat back faces
T_1	bearing height, double-direction thrust bearing with flat back faces

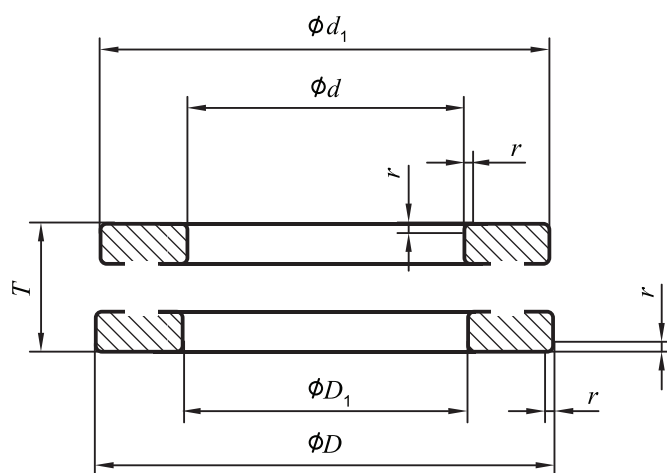

Figure 1 — Single-direction thrust bearing with flat back faces

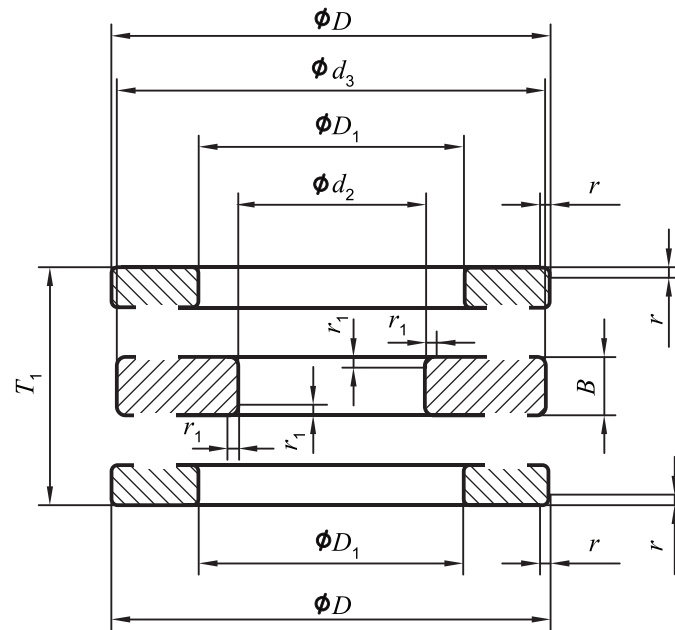

Figure 2 — Double-direction thrust bearing with flat back faces

5 Boundary dimensions

5.1 General

The corresponding largest single chamfer dimensions to the $r_{s \min}$ dimensions in Tables 1 to 9 and $r_{1s \min}$ dimensions in Tables 7 to 9 are given in ISO 582.

Chamfer dimensions r and r_1 apply only at the corners indicated in Figures 1 and 2. No dimensions are given for other corners; however, they should not be sharp.

5.2 Single-direction thrust bearings with flat back faces

Dimensions for single-direction thrust bearings with flat back faces are given in Tables 1 to 6.

Table 1 — Single-direction thrust bearings — Diameter series 0

Dimensions in millimetres

d	D	$r_{s \min}$	Dimension series		
			70	90	10
			T		
4	12	0,3	4	—	6
6	16	0,3	5	—	7
8	18	0,3	5	—	7
10	20	0,3	5	—	7
12	22	0,3	5	—	7
15	26	0,3	5	—	7
17	28	0,3	5	—	7
20	32	0,3	6	—	8

Table 1 (continued)

<i>d</i>	<i>D</i>	<i>r_s min</i>	Dimension series		
			70	90	10
			<i>T</i>		
25	37	0,3	6	—	8
30	42	0,3	6	—	8
35	47	0,3	6	—	8
40	52	0,3	6	—	9
45	60	0,3	7	—	10
50	65	0,3	7	—	10
55	70	0,3	7	—	10
60	75	0,3	7	—	10
65	80	0,3	7	—	10
70	85	0,3	7	—	10
75	90	0,3	7	—	10
80	95	0,3	7	—	10
85	100	0,3	7	—	10
90	105	0,3	7	—	10
100	120	0,6	9	—	14
110	130	0,6	9	—	14
120	140	0,6	9	—	14
130	150	0,6	9	—	14
140	160	0,6	9	—	14
150	170	0,6	9	—	14
160	180	0,6	9	—	14
170	190	0,6	9	—	14
180	200	0,6	9	—	14
190	215	1	11	—	17
200	225	1	11	—	17
220	250	1	14	—	22
240	270	1	14	—	22
260	290	1	14	—	22
280	310	1	14	—	22
300	340	1	18	24	30
320	360	1	18	24	30
340	380	1	18	24	30

Table 1 (continued)

<i>d</i>	<i>D</i>	<i>r_s min</i>	Dimension series		
			70	90	10
			<i>T</i>		
360	400	1	18	24	30
380	420	1	18	24	30
400	440	1	18	24	30
420	460	1	18	24	30
440	480	1	18	24	30
460	500	1	18	24	30
480	520	1	18	24	30
500	540	1	18	24	30
530	580	1,1	23	30	38
560	610	1,1	23	30	38
600	650	1,1	23	30	38
630	680	1,1	23	30	38
670	730	1,5	27	36	45
710	780	1,5	32	42	53
750	820	1,5	32	42	53
800	870	1,5	32	42	53
850	920	1,5	32	42	53
900	980	2	36	48	63
950	1 030	2	36	48	63
1 000	1 090	2,1	41	54	70
1 060	1 150	2,1	41	54	70
1 120	1 220	2,1	45	60	80
1 180	1 280	2,1	45	60	80
1 250	1 360	3	50	67	85
1 320	1 440	3	—	—	95
1 400	1 520	3	—	—	95
1 500	1 630	4	—	—	105
1 600	1 730	4	—	—	105
1 700	1 840	4	—	—	112
1 800	1 950	4	—	—	120
1 900	2 060	5	—	—	130
2 000	2 160	5	—	—	130
2 120	2 300	5	—	—	140

Table 1 (continued)

<i>d</i>	<i>D</i>	<i>r_s min</i>	Dimension series		
			70	90	10
			<i>T</i>		
2 240	2 430	5	—	—	150
2 360	2 550	5	—	—	150
2 500	2 700	5	—	—	160

Table 2 — Single-direction thrust bearings — Diameter series 1

Dimensions in millimetres

<i>d</i>	<i>D</i>	<i>r_s min</i>	Dimension series				
			71	91	11		
			<i>T</i>			<i>d_{1s} max</i>	<i>D_{1s} min</i>
10	24	0,3	6	—	9	24	11
12	26	0,3	6	—	9	26	13
15	28	0,3	6	—	9	28	16
17	30	0,3	6	—	9	30	18
20	35	0,3	7	—	10	35	21
25	42	0,6	8	—	11	42	26
30	47	0,6	8	—	11	47	32
35	52	0,6	8	—	12	52	37
40	60	0,6	9	—	13	60	42
45	65	0,6	9	—	14	65	47
50	70	0,6	9	—	14	70	52
55	78	0,6	10	—	16	78	57
60	85	1	11	—	17	85	62
65	90	1	11	—	18	90	67
70	95	1	11	—	18	95	72
75	100	1	11	—	19	100	77
80	105	1	11	—	19	105	82
85	110	1	11	—	19	110	87
90	120	1	14	—	22	120	92
100	135	1	16	21	25	135	102
110	145	1	16	21	25	145	112
120	155	1	16	21	25	155	122
130	170	1	18	24	30	170	132
140	180	1	18	24	31	178	142
150	190	1	18	24	31	188	152

Table 2 (continued)

<i>d</i>	<i>D</i>	<i>r</i> _{s min}	Dimension series				
			71	91	11		
			<i>T</i>			<i>d</i> _{1s max}	<i>D</i> _{1s min}
160	200	1	18	24	31	198	162
170	215	1,1	20	27	34	213	172
180	225	1,1	20	27	34	222	183
190	240	1,1	23	30	37	237	193
200	250	1,1	23	30	37	247	203
220	270	1,1	23	30	37	267	223
240	300	1,5	27	36	45	297	243
260	320	1,5	27	36	45	317	263
280	350	1,5	32	42	53	347	283
300	380	2	36	48	62	376	304
320	400	2	36	48	63	396	324
340	420	2	36	48	64	416	344
360	440	2	36	48	65	436	364
380	460	2	36	48	65	456	384
400	480	2	36	48	65	476	404
420	500	2	36	48	65	495	424
440	540	2,1	45	60	80	535	444
460	560	2,1	45	60	80	555	464
480	580	2,1	45	60	80	575	484
500	600	2,1	45	60	80	595	504
530	640	3	50	67	85	635	534
560	670	3	50	67	85	665	564
600	710	3	50	67	85	705	604
630	750	3	54	73	95	745	634
670	800	4	58	78	105	795	674
710	850	4	63	85	112	845	714
750	900	4	67	90	120	895	755
800	950	4	67	90	120	945	805
850	1 000	4	67	90	120	995	855
900	1 060	5	73	95	130	1 055	905
950	1 120	5	78	103	135	1 115	955
1 000	1 180	5	82	109	140	1 175	1 005

Table 2 (continued)

<i>d</i>	<i>D</i>	<i>r</i> _{s min}	Dimension series				
			71	91	11		
			<i>T</i>			<i>d</i> _{1s max}	<i>D</i> _{1s min}
1 060	1 250	5	85	115	150	1 245	1 065
1 120	1 320	5	90	122	160	1 315	1 125
1 180	1 400	6	100	132	175	1 395	1 185
1 250	1 460	6	—	—	175	1 455	1 255
1 320	1 540	6	—	—	175	1 535	1 325
1 400	1 630	6	—	—	180	1 620	1 410
1 500	1 750	6	—	—	195	1 740	1 510
1 600	1 850	6	—	—	195	1 840	1 610
1 700	1 970	7,5	—	—	212	1 960	1 710
1 800	2 080	7,5	—	—	220	2 070	1 810
1 900	2 180	7,5	—	—	220	2 170	1 910
2 000	2 300	7,5	—	—	236	2 290	2 010
2 120	2 430	7,5	—	—	243	2 420	2 130
2 240	2 570	9,5	—	—	258	2 560	2 250
2 360	2 700	9,5	—	—	265	2 690	2 370
2 500	2 850	9,5	—	—	272	2 840	2 510

Table 3 — Single-direction thrust bearings — Diameter series 2

Dimensions in millimetres

<i>d</i>	<i>D</i>	<i>r</i> _{s min}	Dimension series				
			72	92	12		
			<i>T</i>			<i>d</i> _{1s max}	<i>D</i> _{1s min}
4	16	0,3	6	—	8	16	4
6	20	0,3	6	—	9	20	6
8	22	0,3	6	—	9	22	8
10	26	0,6	7	—	11	26	12
12	28	0,6	7	—	11	28	14
15	32	0,6	8	—	12	32	17
17	35	0,6	8	—	12	35	19
20	40	0,6	9	—	14	40	22
25	47	0,6	10	—	15	47	27
30	52	0,6	10	—	16	52	32
35	62	1	12	—	18	62	37
40	68	1	13	—	19	68	42

Table 3 (continued)

<i>d</i>	<i>D</i>	<i>r_s min</i>	Dimension series				
			72	92	12		
			<i>T</i>			<i>d_{1s} max</i>	<i>D_{1s} min</i>
45	73	1	13	—	20	73	47
50	78	1	13	—	22	78	52
55	90	1	16	21	25	90	57
60	95	1	16	21	26	95	62
65	100	1	16	21	27	100	67
70	105	1	16	21	27	105	72
75	110	1	16	21	27	110	77
80	115	1	16	21	28	115	82
85	125	1	18	24	31	125	88
90	135	1,1	20	27	35	135	93
100	150	1,1	23	30	38	150	103
110	160	1,1	23	30	38	160	113
120	170	1,1	23	30	39	170	123
130	190	1,5	27	36	45	187	133
140	200	1,5	27	36	46	197	143
150	215	1,5	29	39	50	212	153
160	225	1,5	29	39	51	222	163
170	240	1,5	32	42	55	237	173
180	250	1,5	32	42	56	247	183
190	270	2	36	48	62	267	194
200	280	2	36	48	62	277	204
220	300	2	36	48	63	297	224
240	340	2,1	45	60	78	335	244
260	360	2,1	45	60	79	355	264
280	380	2,1	45	60	80	375	284
300	420	3	54	73	95	415	304
320	440	3	54	73	95	435	325
340	460	3	54	73	96	455	345
360	500	4	63	85	110	495	365
380	520	4	63	85	112	515	385
400	540	4	63	85	112	535	405
420	580	5	73	95	130	575	425
440	600	5	73	95	130	595	445

Table 3 (continued)

<i>d</i>	<i>D</i>	<i>r</i> _{s min}	Dimension series				
			72	92	12		
			<i>T</i>			<i>d</i> _{1s max}	<i>D</i> _{1s min}
460	620	5	73	95	130	615	465
480	650	5	78	103	135	645	485
500	670	5	78	103	135	665	505
530	710	5	82	109	140	705	535
560	750	5	85	115	150	745	565
600	800	5	90	122	160	795	605
630	850	6	100	132	175	845	635
670	900	6	103	140	180	895	675
710	950	6	109	145	190	945	715
750	1 000	6	112	150	195	995	755
800	1 060	7,5	118	155	205	1 055	805
850	1 120	7,5	122	160	212	1 115	855
900	1 180	7,5	125	170	220	1 175	905
950	1 250	7,5	136	180	236	1 245	955
1 000	1 320	9,5	145	190	250	1 315	1 005
1 060	1 400	9,5	155	206	265	1 395	1 065
1 120	1 460	9,5	—	206	—	—	—
1 180	1 520	9,5	—	206	—	—	—
1 250	1 610	9,5	—	216	—	—	—
1 320	1 700	9,5	—	228	—	—	—
1 400	1 790	12	—	234	—	—	—
1 500	1 920	12	—	252	—	—	—
1 600	2 040	15	—	264	—	—	—
1 700	2 160	15	—	276	—	—	—
1 800	2 280	15	—	288	—	—	—

Table 4 — Single-direction thrust bearings — Diameter series 3

Dimensions in millimetres

<i>d</i>	<i>D</i>	<i>r</i> _{s min}	Dimension series				
			73	93	13		
			<i>T</i>			<i>d</i> _{1s max}	<i>D</i> _{1s min}
4	20	0,6	7	—	11	20	4
6	24	0,6	8	—	12	24	6
8	26	0,6	8	—	12	26	8

Table 4 (continued)

<i>d</i>	<i>D</i>	<i>r_s min</i>	Dimension series				
			73	93	13		
			<i>T</i>			<i>d_{1s} max</i>	<i>D_{1s} min</i>
10	30	0,6	9	—	14	30	10
12	32	0,6	9	—	14	32	12
15	37	0,6	10	—	15	37	15
17	40	0,6	10	—	16	40	19
20	47	1	12	—	18	47	22
25	52	1	12	—	18	52	27
30	60	1	14	—	21	60	32
35	68	1	15	—	24	68	37
40	78	1	17	22	26	78	42
45	85	1	18	24	28	85	47
50	95	1,1	20	27	31	95	52
55	105	1,1	23	30	35	105	57
60	110	1,1	23	30	35	110	62
65	115	1,1	23	30	36	115	67
70	125	1,1	25	34	40	125	72
75	135	1,5	27	36	44	135	77
80	140	1,5	27	36	44	140	82
85	150	1,5	29	39	49	150	88
90	155	1,5	29	39	50	155	93
100	170	1,5	32	42	55	170	103
110	190	2	36	48	63	187	113
120	210	2,1	41	54	70	205	123
130	225	2,1	42	58	75	220	134
140	240	2,1	45	60	80	235	144
150	250	2,1	45	60	80	245	154
160	270	3	50	67	87	265	164
170	280	3	50	67	87	275	174
180	300	3	54	73	95	295	184
190	320	4	58	78	105	315	195
200	340	4	63	85	110	335	205
220	360	4	63	85	112	355	225
240	380	4	63	85	112	375	245

Table 4 (continued)

<i>d</i>	<i>D</i>	<i>r_s min</i>	Dimension series				
			73	93	13		
			<i>T</i>			<i>d_{1s} max</i>	<i>D_{1s} min</i>
260	420	5	73	95	130	415	265
280	440	5	73	95	130	435	285
300	480	5	82	109	140	475	305
320	500	5	82	109	140	495	325
340	540	5	90	122	160	535	345
360	560	5	90	122	160	555	365
380	600	6	100	132	175	595	385
400	620	6	100	132	175	615	405
420	650	6	103	140	180	645	425
440	680	6	109	145	190	675	445
460	710	6	112	150	195	705	465
480	730	6	112	150	195	725	485
500	750	6	112	150	195	745	505
530	800	7,5	122	160	212	795	535
560	850	7,5	132	175	224	845	565
600	900	7,5	136	180	236	895	605
630	950	9,5	145	190	250	945	635
670	1 000	9,5	150	200	258	995	675
710	1 060	9,5	160	212	272	1 055	715
750	1 120	9,5	165	224	290	1 115	755
800	1 180	9,5	170	230	300	1 175	805
850	1 250	12	180	243	315	1 245	855
900	1 320	12	190	250	335	1 315	905
950	1 400	12	200	272	355	1 395	955
1 000	1 460	12	—	276	—	—	—
1 060	1 540	15	—	288	—	—	—
1 120	1 630	15	—	306	—	—	—
1 180	1 710	15	—	318	—	—	—
1 250	1 800	19	—	330	—	—	—
1 320	1 900	19	—	348	—	—	—
1 400	2 000	19	—	360	—	—	—
1 500	2 140	19	—	384	—	—	—
1 600	2 270	19	—	402	—	—	—

Table 5 — Single-direction thrust bearings — Diameter series 4

Dimensions in millimetres

<i>d</i>	<i>D</i>	<i>r</i> _{s min}	Dimension series				
			74	94	14		
			<i>T</i>			<i>d</i> _{1s max}	<i>D</i> _{1s min}
25	60	1	16	21	24	60	27
30	70	1	18	24	28	70	32
35	80	1,1	20	27	32	80	37
40	90	1,1	23	30	36	90	42
45	100	1,1	25	34	39	100	47
50	110	1,5	27	36	43	110	52
55	120	1,5	29	39	48	120	57
60	130	1,5	32	42	51	130	62
65	140	2	34	45	56	140	68
70	150	2	36	48	60	150	73
75	160	2	38	51	65	160	78
80	170	2,1	41	54	68	170	83
85	180	2,1	42	58	72	177	88
90	190	2,1	45	60	77	187	93
100	210	3	50	67	85	205	103
110	230	3	54	73	95	225	113
120	250	4	58	78	102	245	123
130	270	4	63	85	110	265	134
140	280	4	63	85	112	275	144
150	300	4	67	90	120	295	154
160	320	5	73	95	130	315	164
170	340	5	78	103	135	335	174
180	360	5	82	109	140	355	184
190	380	5	85	115	150	375	195
200	400	5	90	122	155	395	205
220	420	6	90	122	160	415	225
240	440	6	90	122	160	435	245
260	480	6	100	132	175	475	265
280	520	6	109	145	190	515	285
300	540	6	109	145	190	535	305
320	580	7,5	118	155	205	575	325
340	620	7,5	125	170	220	615	345

Table 5 (continued)

<i>d</i>	<i>D</i>	<i>r</i> _{s min}	Dimension series				
			74	94	14		
			<i>T</i>			<i>d</i> _{1s max}	<i>D</i> _{1s min}
360	640	7,5	125	170	220	635	365
380	670	7,5	132	175	224	665	385
400	710	7,5	140	185	243	705	405
420	730	7,5	140	185	243	725	425
440	780	9,5	155	206	265	775	445
460	800	9,5	155	206	265	795	465
480	850	9,5	165	224	290	845	485
500	870	9,5	165	224	290	865	505
530	920	9,5	175	236	308	915	535
560	980	12	190	250	335	975	565
600	1 030	12	195	258	335	1 025	605
630	1 090	12	206	280	365	1 085	635
670	1 150	15	218	290	375	1 145	675
710	1 220	15	230	308	400	1 215	715
750	1 280	15	236	315	412	1 275	755
800	1 360	15	250	335	438	1 355	805
850	1 440	15	—	354	—	—	—
900	1 520	15	—	372	—	—	—
950	1 600	15	—	390	—	—	—
1 000	1 670	15	—	402	—	—	—
1 060	1 770	15	—	426	—	—	—
1 120	1 860	15	—	444	—	—	—
1 180	1 950	19	—	462	—	—	—
1 250	2 050	19	—	480	—	—	—
1 320	2 160	19	—	505	—	—	—
1 400	2 280	19	—	530	—	—	—

Table 6 — Single-direction thrust bearings — Diameter series 5

Dimensions in millimetres

<i>d</i>	<i>D</i>	<i>r</i> _{s min}	Dimension series	
			95	<i>T</i>
17	52	1		21
20	60	1		24
25	73	1,1		29
30	85	1,1		34
35	100	1,1		39
40	110	1,5		42
45	120	2		45
50	135	2		51
55	150	2,1		58
60	160	2,1		60
65	170	2,1		63
70	180	3		67
75	190	3		69
80	200	3		73
85	215	4		78
90	225	4		82
100	250	4		90
110	270	5		95
120	300	5		109
130	320	5		115
140	340	5		122
150	360	6		125
160	380	6		132
170	400	6		140
180	420	6		145
190	440	6		150
200	460	7,5		155
220	500	7,5		170
240	540	7,5		180
260	580	9,5		190
280	620	9,5		206
300	670	9,5		224

Table 6 (continued)

<i>d</i>	<i>D</i>	<i>r</i> _{s min}	Dimension series	
			95	<i>T</i>
320	710	9,5		236
340	750	12		243
360	780	12		250
380	820	12		265
400	850	12		272
420	900	15		290
440	950	15		308
460	980	15		315
480	1 000	15		315
500	1 060	15		335
530	1 090	15		335
560	1 150	15		355
600	1 220	15		375
630	1 280	15		388
670	1 320	15		388
710	1 400	15		412

5.3 Double-direction thrust bearings with flat back faces

Dimensions for double-direction thrust bearings with flat back faces are given in [Tables 7 to 9](#).

Table 7 — Double-direction thrust bearings — Diameter series 2 — Dimension series 22

Dimensions in millimetres

<i>d</i> ₂	<i>d</i> ^a	<i>D</i>	<i>r</i> _{s min}	<i>r</i> _{1s min}	<i>T</i> ₁	<i>B</i>	<i>d</i> _{3s max}	<i>D</i> _{1s min}
10	15	32	0,6	0,3	22	5	32	17
15	20	40	0,6	0,3	26	6	40	22
20	25	47	0,6	0,3	28	7	47	27
25	30	52	0,6	0,3	29	7	52	32
30	35	62	1	0,3	34	8	62	37
30	40	68	1	0,6	36	9	68	42
35	45	73	1	0,6	37	9	73	47
40	50	78	1	0,6	39	9	78	52
45	55	90	1	0,6	45	10	90	57
50	60	95	1	0,6	46	10	95	62

^a *d* is the bore diameter of shaft washer of corresponding diameter series 2, single-direction bearing, given in [Table 3](#).

Table 7 (continued)

d_2	d^a	D	$r_{s \text{ min}}$	$r_{1s \text{ min}}$	T_1	B	$d_{3s \text{ max}}$	$D_{1s \text{ min}}$
55	65	100	1	0,6	47	10	100	67
55	70	105	1	1	47	10	105	72
60	75	110	1	1	47	10	110	77
65	80	115	1	1	48	10	115	82
70	85	125	1	1	55	12	125	88
75	90	135	1,1	1	62	14	135	93
85	100	150	1,1	1	67	15	150	103
95	110	160	1,1	1	67	15	160	113
100	120	170	1,1	1,1	68	15	170	123
110	130	190	1,5	1,1	80	18	189,5	133
120	140	200	1,5	1,1	81	18	199,5	143
130	150	215	1,5	1,1	89	20	214,5	153
140	160	225	1,5	1,1	90	20	224,5	163
150	170	240	1,5	1,1	97	21	239,5	173
150	180	250	1,5	2	98	21	249	183
160	190	270	2	2	109	24	269	194
170	200	280	2	2	109	24	279	204
190	220	300	2	2	110	24	299	224

^a d is the bore diameter of shaft washer of corresponding diameter series 2, single-direction bearing, given in [Table 3](#).

Table 8 — Double-direction thrust bearings — Diameter series 3 — Dimension series 23

Dimensions in millimetres

d_2	d^a	D	$r_{s \text{ min}}$	$r_{1s \text{ min}}$	T_1	B	$d_{3s \text{ max}}$	$D_{1s \text{ min}}$
20	25	52	1	0,3	34	8	52	27
25	30	60	1	0,3	38	9	60	32
30	35	68	1	0,3	44	10	68	37
30	40	78	1	0,6	49	12	78	42
35	45	85	1	0,6	52	12	85	47
40	50	95	1,1	0,6	58	14	95	52
45	55	105	1,1	0,6	64	15	105	57
50	60	110	1,1	0,6	64	15	110	62
55	65	115	1,1	0,6	65	15	115	67
55	70	125	1,1	1	72	16	125	72
60	75	135	1,5	1	79	18	135	77
65	80	140	1,5	1	79	18	140	82

^a d is the bore diameter of shaft washer of corresponding diameter series 3, single-direction bearing, given in [Table 4](#).

Table 8 (continued)

d_2	d^a	D	$r_{s \text{ min}}$	$r_{1s \text{ min}}$	T_1	B	$d_{3s \text{ max}}$	$D_{1s \text{ min}}$
70	85	150	1,5	1	87	19	150	88
75	90	155	1,5	1	88	19	155	93
85	100	170	1,5	1	97	21	170	103
95	110	190	2	1	110	24	189,5	113
100	120	210	2,1	1,1	123	27	209,5	123
110	130	225	2,1	1,1	130	30	224	134
120	140	240	2,1	1,1	140	31	239	144
130	150	250	2,1	1,1	140	31	249	154
140	160	270	3	1,1	153	33	269	164
150	170	280	3	1,1	153	33	279	174
150	180	300	3	2	165	37	299	184
160	190	320	4	2	183	40	319	195
170	200	340	4	2	192	42	339	205

^a d is the bore diameter of shaft washer of corresponding diameter series 3, single-direction bearing, given in [Table 4](#).

Table 9 — Double-direction thrust bearings — Diameter series 4 — Dimension series 24

Dimensions in millimetres

d_2	d^a	D	$r_{s \text{ min}}$	$r_{1s \text{ min}}$	T_1	B	$d_{3s \text{ max}}$	$D_{1s \text{ min}}$
15	25	60	1	0,6	45	11	60	27
20	30	70	1	0,6	52	12	70	32
25	35	80	1,1	0,6	59	14	80	37
30	40	90	1,1	0,6	65	15	90	42
35	45	100	1,1	0,6	72	17	100	47
40	50	110	1,5	0,6	78	18	110	52
45	55	120	1,5	0,6	87	20	120	57
50	60	130	1,5	0,6	93	21	130	62
50	65	140	2	1	101	23	140	68
55	70	150	2	1	107	24	150	73
60	75	160	2	1	115	26	160	78
65	80	170	2,1	1	120	27	170	83
65	85	180	2,1	1,1	128	29	179,5	88
70	90	190	2,1	1,1	135	30	189,5	93
80	100	210	3	1,1	150	33	209,5	103
90	110	230	3	1,1	166	37	229	113
95	120	250	4	1,5	177	40	249	123

^a d is the bore diameter of shaft washer of corresponding diameter series 4, single-direction bearing, given in [Table 5](#).

Table 9 (continued)

d_2	d^a	D	$r_{s \text{ min}}$	$r_{1s \text{ min}}$	T_1	B	$d_{3s \text{ max}}$	$D_{1s \text{ min}}$
100	130	270	4	2	192	42	269	134
110	140	280	4	2	196	44	279	144
120	150	300	4	2	209	46	299	154
130	160	320	5	2	226	50	319	164
135	170	340	5	2,1	236	50	339	174
140	180	360	5	3	245	52	359	184

^a d is the bore diameter of shaft washer of corresponding diameter series 4, single-direction bearing, given in [Table 5](#).

Annex A (informative)

Guidelines for the extension of this International Standard for single-direction thrust bearings

A.1 General

For any new dimension not numerically determined in this International Standard, the following guidelines should be used. The formula given for outside diameter and height should not, however, be used for definite determination of the boundary dimension values; they may often require to be modified in order to maintain the continuity of this International Standard to obtain suitable bearing proportions and to permit selection of preferred dimensions.

Accordingly, any new dimensions will have to be approved by ISO.

A.2 Bore diameters

Bore diameters, d , of shaft washers, above $d = 500$ mm, should be selected from the R 40 series of preferred numbers given in ISO 3.^[1]

Bore diameters of shaft washers already appearing in this International Standard should be chosen for preference.

A.3 Outside diameters

Outside diameters, D , of housing washers should be calculated using Formula (A.1):

$$D = d + f_D d^{0,8} \quad (\text{A.1})$$

where

D is a numerical value of the outside diameter of the housing washer, expressed in millimetres (mm);

d is a numerical value of the bore diameter of the shaft washer, expressed in millimetres (mm);

f_D is a factor, the appropriate value is given in [Table A.1](#).

Table A.1 — Values of f_D

Diameter series	0	1	2	3	4	5
f_D	0,36	0,72	1,2	1,84	2,68	3,8

Outside diameter dimensions already appearing in this International Standard should be chosen for preference. New outside diameter dimensions should be rounded as shown in [Table A.2](#).

Table A.2 — Rounding for D

Dimensions in millimetres

D		Rounded to the nearest
>	≤	
—	3	0,5
3	80	1
80	230	5
230	—	10

A.4 Bearing heights

Bearing heights, T , should be calculated, in millimetres, using Formula (A.2):

$$T = f_T \frac{D - d}{2} \quad (\text{A.2})$$

where

D is a numerical value of the outside diameter of the housing washer, expressed in millimetres (mm);

d is a numerical value of the bore diameter of the shaft washer, expressed in millimetres (mm);

f_T is a factor, the appropriate value is given in [Table A.3](#).

Table A.3 — Values of f_T

Height series	7	9	1
f_T	0,9	1,2	1,6

New height dimensions should be rounded as shown in [Table A.4](#).

Table A.4 — Rounding for T

Dimensions in millimetres

T		Rounded to the nearest
>	≤	
—	3	0,1
3	4	0,5
4	500	1
500	—	5

A.5 Smallest single chamfer dimension

Smallest single chamfer dimension $r_{s \min}$ should be selected from the $r_{s \min}$ values listed in ISO 582 and, in principle, be that value which is nearest to but not larger than the smaller of the two values: 7 % of the height T and 7 % of the sectional width $(D - d)/2$.

Bibliography

- [1] ISO 3, *Preferred numbers — Series of preferred numbers*
- [2] ISO 20516, *Rolling bearings — Aligning thrust ball bearings and aligning seat washers — Boundary dimensions*

British Standards Institution (BSI)

BSI is the national body responsible for preparing British Standards and other standards-related publications, information and services.

BSI is incorporated by Royal Charter. British Standards and other standardization products are published by BSI Standards Limited.

About us

We bring together business, industry, government, consumers, innovators and others to shape their combined experience and expertise into standards-based solutions.

The knowledge embodied in our standards has been carefully assembled in a dependable format and refined through our open consultation process. Organizations of all sizes and across all sectors choose standards to help them achieve their goals.

Information on standards

We can provide you with the knowledge that your organization needs to succeed. Find out more about British Standards by visiting our website at bsigroup.com/standards or contacting our Customer Services team or Knowledge Centre.

Buying standards

You can buy and download PDF versions of BSI publications, including British and adopted European and international standards, through our website at bsigroup.com/shop, where hard copies can also be purchased.

If you need international and foreign standards from other Standards Development Organizations, hard copies can be ordered from our Customer Services team.

Subscriptions

Our range of subscription services are designed to make using standards easier for you. For further information on our subscription products go to bsigroup.com/subscriptions.

With **British Standards Online (BSOL)** you'll have instant access to over 55,000 British and adopted European and international standards from your desktop. It's available 24/7 and is refreshed daily so you'll always be up to date.

You can keep in touch with standards developments and receive substantial discounts on the purchase price of standards, both in single copy and subscription format, by becoming a **BSI Subscribing Member**.

PLUS is an updating service exclusive to BSI Subscribing Members. You will automatically receive the latest hard copy of your standards when they're revised or replaced.

To find out more about becoming a BSI Subscribing Member and the benefits of membership, please visit bsigroup.com/shop.

With a **Multi-User Network Licence (MUNL)** you are able to host standards publications on your intranet. Licences can cover as few or as many users as you wish. With updates supplied as soon as they're available, you can be sure your documentation is current. For further information, email bsmusales@bsigroup.com.

BSI Group Headquarters

389 Chiswick High Road London W4 4AL UK

Revisions

Our British Standards and other publications are updated by amendment or revision.

We continually improve the quality of our products and services to benefit your business. If you find an inaccuracy or ambiguity within a British Standard or other BSI publication please inform the Knowledge Centre.

Copyright

All the data, software and documentation set out in all British Standards and other BSI publications are the property of and copyrighted by BSI, or some person or entity that owns copyright in the information used (such as the international standardization bodies) and has formally licensed such information to BSI for commercial publication and use. Except as permitted under the Copyright, Designs and Patents Act 1988 no extract may be reproduced, stored in a retrieval system or transmitted in any form or by any means – electronic, photocopying, recording or otherwise – without prior written permission from BSI. Details and advice can be obtained from the Copyright & Licensing Department.

Useful Contacts:

Customer Services

Tel: +44 845 086 9001

Email (orders): orders@bsigroup.com

Email (enquiries): cservices@bsigroup.com

Subscriptions

Tel: +44 845 086 9001

Email: subscriptions@bsigroup.com

Knowledge Centre

Tel: +44 20 8996 7004

Email: knowledgecentre@bsigroup.com

Copyright & Licensing

Tel: +44 20 8996 7070

Email: copyright@bsigroup.com



...making excellence a habit.™