

BS IEC 63003:2015



BSI Standards Publication

**Standard for the common  
test interface pin map  
configuration for high-density,  
single-tier electronics test  
requirements utilizing  
IEEE Std 1505™**

**bsi.**

...making excellence a habit.™

### **National foreword**

This British Standard is the UK implementation of IEC 63003:2015.

The UK participation in its preparation was entrusted to Technical Committee EPL/501, Electronic Assembly Technology.

A list of organizations represented on this committee can be obtained on request to its secretary.

This publication does not purport to include all the necessary provisions of a contract. Users are responsible for its correct application.

© The British Standards Institution 2016.

Published by BSI Standards Limited 2016

ISBN 978 0 580 91106 4

ICS 25.040.01

**Compliance with a British Standard cannot confer immunity from legal obligations.**

This British Standard was published under the authority of the Standards Policy and Strategy Committee on 31 January 2016.

### **Amendments/corrigenda issued since publication**

<b>Date</b>	<b>Text affected</b>
-------------	----------------------

---



# INTERNATIONAL IEEE Std 1505.1™ STANDARD



---

**Standard for the common test interface pin map configuration for high-density, single-tier electronics test requirements utilizing IEEE Std 1505™**

INTERNATIONAL  
ELECTROTECHNICAL  
COMMISSION

---

ICS 25.040

ISBN 978-2-8322-2941-5

**Warning! Make sure that you obtained this publication from an authorized distributor.**

## Contents

1. Overview .....	1
1.1 Scope .....	1
1.2 Purpose .....	2
1.3 Statement of the problem.....	2
2. Normative references.....	3
3. Definitions, acronyms, and abbreviations .....	4
3.1 Definitions .....	4
3.2 Specification terms .....	4
3.3 Acronyms and abbreviations .....	4
4. Common test interface requirements .....	8
4.1 Introduction .....	8
4.2 CTI open system requirements .....	8
4.3 CTI cost requirements.....	9
4.4 Vertical integration test support requirements .....	9
4.5 CTI configuration/interoperability requirements .....	10
4.6 Maintainability/end-user support requirements .....	10
4.7 Scalable architecture requirements .....	10
4.8 Physical framework requirements .....	12
4.9 Reliability requirements.....	17
4.10 CTI connector footprint/parametric requirements .....	18
4.11 CTI pin map requirements .....	22
4.12 CTI pin map input/output configuration .....	33
Annex A (normative) Common test interface signal definitions for pin map.....	34
A.1 Analog instruments (AI) .....	34
A.2 Bus .....	36
A.3 Digital .....	37
A.4 Instrument control.....	37
A.5 Power loads.....	37
A.6 Power supplies .....	38
A.7 Sense and control, DCPS, and loads.....	38
A.8 Switch .....	39
A.9 System .....	40
Annex B (informative) Bibliography.....	159
Annex C (informative) IEEE List of Participants.....	162

# STANDARD FOR THE COMMON TEST INTERFACE PIN MAP CONFIGURATION FOR HIGH-DENSITY, SINGLE-TIER ELECTRONICS TEST REQUIREMENTS UTILIZING IEEE Std 1505™

## FOREWORD

- 1) The International Electrotechnical Commission (IEC) is a worldwide organization for standardization comprising all national electrotechnical committees (IEC National Committees). The object of IEC is to promote international co-operation on all questions concerning standardization in the electrical and electronic fields. To this end and in addition to other activities, IEC publishes International Standards, Technical Specifications, Technical Reports, Publicly Available Specifications (PAS) and Guides (hereafter referred to as "IEC Publication(s)"). Their preparation is entrusted to technical committees; any IEC National Committee interested in the subject dealt with may participate in this preparatory work. International, governmental and non-governmental organizations liaising with the IEC also participate in this preparation.

IEEE Standards documents are developed within IEEE Societies and Standards Coordinating Committees of the IEEE Standards Association (IEEE-SA) Standards Board. IEEE develops its standards through a consensus development process, which brings together volunteers representing varied viewpoints and interests to achieve the final product. Volunteers are not necessarily members of IEEE and serve without compensation. While IEEE administers the process and establishes rules to promote fairness in the consensus development process, IEEE does not independently evaluate, test, or verify the accuracy of any of the information contained in its standards. Use of IEEE Standards documents is wholly voluntary. IEEE documents are made available for use subject to important notices and legal disclaimers (see <http://standards.ieee.org/IPR/disclaimers.html> for more information).

IEC collaborates closely with IEEE in accordance with conditions determined by agreement between the two organizations.

- 2) The formal decisions of IEC on technical matters express, as nearly as possible, an international consensus of opinion on the relevant subjects since each technical committee has representation from all interested IEC National Committees. The formal decisions of IEEE on technical matters, once consensus within IEEE Societies and Standards Coordinating Committees has been reached, is determined by a balanced ballot of materially interested parties who indicate interest in reviewing the proposed standard. Final approval of the IEEE standards document is given by the IEEE Standards Association (IEEE-SA) Standards Board.
- 3) IEC/IEEE Publications have the form of recommendations for international use and are accepted by IEC National Committees/IEEE Societies in that sense. While all reasonable efforts are made to ensure that the technical content of IEC/IEEE Publications is accurate, IEC or IEEE cannot be held responsible for the way in which they are used or for any misinterpretation by any end user.
- 4) In order to promote international uniformity, IEC National Committees undertake to apply IEC Publications (including IEC/IEEE Publications) transparently to the maximum extent possible in their national and regional publications. Any divergence between any IEC/IEEE Publication and the corresponding national or regional publication shall be clearly indicated in the latter.
- 5) IEC and IEEE do not provide any attestation of conformity. Independent certification bodies provide conformity assessment services and, in some areas, access to IEC marks of conformity. IEC and IEEE are not responsible for any services carried out by independent certification bodies.
- 6) All users should ensure that they have the latest edition of this publication.
- 7) No liability shall attach to IEC or IEEE or their directors, employees, servants or agents including individual experts and members of technical committees and IEC National Committees, or volunteers of IEEE Societies and the Standards Coordinating Committees of the IEEE Standards Association (IEEE-SA) Standards Board, for any personal injury, property damage or other damage of any nature whatsoever, whether direct or indirect, or for costs (including legal fees) and expenses arising out of the publication, use of, or reliance upon, this IEC/IEEE Publication or any other IEC or IEEE Publications.
- 8) Attention is drawn to the normative references cited in this publication. Use of the referenced publications is indispensable for the correct application of this publication.
- 9) Attention is drawn to the possibility that implementation of this IEC/IEEE Publication may require use of material covered by patent rights. By publication of this standard, no position is taken with respect to the existence or validity of any patent rights in connection therewith. IEC or IEEE shall not be held responsible for identifying Essential Patent Claims for which a license may be required, for conducting inquiries into the legal validity or scope of Patent Claims or determining whether any licensing terms or conditions provided in connection with submission of a Letter of Assurance, if any, or in any licensing agreements are reasonable or non-discriminatory. Users of this standard are expressly advised that determination of the validity of any patent rights, and the risk of infringement of such rights, is entirely their own responsibility.

International Standard IEC 63003/IEEE Std 1505.1-2008 has been processed through IEC technical committee 91: Electronics assembly technology, under the IEC/IEEE Dual Logo Agreement.

The text of this standard is based on the following documents:

IEEE Std	FDIS	Report on voting
IEEE Std 1505.1-2008	91/1274/FDIS	91/1298/RVD

Full information on the voting for the approval of this standard can be found in the report on voting indicated in the above table.

The IEC Technical Committee and IEEE Technical Committee have decided that the contents of this publication will remain unchanged until the stability date indicated on the IEC web site under "<http://webstore.iec.ch>" in the data related to the specific publication. At this date, the publication will be

- reconfirmed,
- withdrawn,
- replaced by a revised edition, or
- amended.

# **IEEE Standard for the Common Test Interface Pin Map Configuration for High-Density, Single-Tier Electronics Test Requirements Utilizing IEEE Std 1505™**

Sponsor

**IEEE Instrumentation and Measurement Society**

and

**IEEE Standards Coordinating Committee 20 on  
Test and Diagnosis for Electronic Systems**

Approved 26 September 2008

**IEEE-SA Standards Board**

Approved as a Full-Use Standard on 14 June 2013

**IEEE-SA Standards Board**

**Abstract:** This standard represents an extension to the IEEE 1505 receiver fixture interface (RFI) standard specification. Particular emphasis is placed on defining within the IEEE 1505 RFI standard a more specific set of performance requirements that employ a common scalable: (a) pin map configuration; (b) specific connector modules; (c) respective contacts; (d) recommended switching implementation; and (e) legacy automatic test equipment (ATE) transitional devices. This is intentionally done to standardize the footprint and assure mechanical and electrical interoperability between past and future automatic test systems (ATS).

**Keywords:** ATE, ATS, fixture, ICD, IEEE 1505.1<sup>TM</sup>, interface, ITA, mass termination, receiver, scalable, TPS, UUT



## IEEE Introduction

This introduction is not part of IEEE Std 1505.1-2008, IEEE Standard for the Common Test Interface Pin Map Configuration for High-Density, Single-Tier Electronics Test Requirements Utilizing IEEE Std 1505™.

This standard stems from the history of ATE implementations having unique input/output (I/O) pin out definitions. This uniqueness has prevented the interoperability of test program sets (TPSs) among different ATEs within the same organizations. Even if the same RFI was used by the target ATE, the signals I/O could not be guaranteed to be at the same pin location. This is due to there being no suitable standard pin out definition for general purpose electronic testing applications.

IEEE Std 1505-2006<sup>a</sup> has addressed part of the interoperability problem by defining the common mechanical interface for the ATE. This project takes the TPS interoperability problem one step further toward completion by standardizing the electrical signal I/O pin map for general purpose electronic testing applications.

Particular emphasis is placed on defining within the IEEE 1505 RFI standard a more specific set of performance requirements that employ a common scalable: (a) framework; (b) pin map configuration; (c) specific connector modules; (d) respective contacts; (e) recommended switching implementation; and (f) legacy ATE transitional devices. This is intentionally done to standardize the footprint and assure mechanical and electrical interoperability between past and future ATS. The suggested mechanical and electrical requirements necessary to implement a specific IEEE 1505 RFI product in support of a common test interface (CTI) across all U.S. Department of Defense (DoD) defense agencies, related aerospace industry, and a variety of non-U.S. government agencies such as the U.K. Ministry of Defense (MoD) is provided.

The DoD is a major buyer and user of ATE; however, existing acquisition guidance desires the use of commercial standards and/or best practices for these systems. Suitable standards currently do not exist in the commercial marketplace; therefore, this standard will provide such specification.

## Notice to users

Users of IEEE Standards documents should consult all applicable laws and regulations. Compliance with the provisions of any IEEE Standards document does not imply compliance to any applicable regulatory requirements. Implementers of the standard are responsible for observing or referring to the applicable regulatory requirements. IEEE does not, by the publication of its standards, intend to urge action that is not in compliance with applicable laws, and these documents may not be construed as doing so.

## Copyrights

This document is copyrighted by the IEEE. It is made available for a wide variety of both public and private uses. These include both use, by reference, in laws and regulations, and use in private self-regulation, standardization, and the promotion of engineering practices and methods. By making this document available for use and adoption by public authorities and private users, the IEEE does not waive any rights in copyright to this document.

---

<sup>a</sup> Information on references can be found in Clause 2.

## Updating of IEEE documents

Users of IEEE Standards documents should be aware that these documents may be superseded at any time by the issuance of new editions or may be amended from time to time through the issuance of amendments, corrigenda, or errata. An official IEEE document at any point in time consists of the current edition of the document together with any amendments, corrigenda, or errata then in effect. In order to determine whether a given document is the current edition and whether it has been amended through the issuance of amendments, corrigenda, or errata, visit the IEEE-SA Website at <http://standards.ieee.org/index.html> or contact the IEEE at the address listed previously. For more information about the IEEE Standards Association or the IEEE standards development process, visit IEEE-SA Website at <http://standards.ieee.org/index.html>.

## Errata

Errata, if any, for this and all other standards can be accessed at the following URL: <http://standards.ieee.org/findstds/errata/index.html>. Users are encouraged to check this URL for errata periodically.

## Patents

Attention is called to the possibility that implementation of this standard may require use of subject matter covered by patent rights. By publication of this standard, no position is taken by the IEEE with respect to the existence or validity of any patent rights in connection therewith. If a patent holder or patent applicant has filed a statement of assurance via an Accepted Letter of Assurance, then the statement is listed on the IEEE-SA Website at <http://standards.ieee.org/about/sasb/patcom/patents.html>. Letters of Assurance may indicate whether the Submitter is willing or unwilling to grant licenses under patent rights without compensation or under reasonable rates, with reasonable terms and conditions that are demonstrably free of any unfair discrimination to applicants desiring to obtain such licenses.

Essential Patent Claims may exist for which a Letter of Assurance has not been received. The IEEE is not responsible for identifying Essential Patent Claims for which a license may be required, for conducting inquiries into the legal validity or scope of Patents Claims, or determining whether any licensing terms or conditions provided in connection with submission of a Letter of Assurance, if any, or in any licensing agreements are reasonable or non-discriminatory. Users of this standard are expressly advised that determination of the validity of any patent rights, and the risk of infringement of such rights, is entirely their own responsibility. Further information may be obtained from the IEEE Standards Association.

# Standard for the Common Test Interface Pin Map Configuration for High-Density, Single-Tier Electronics Test Requirements Utilizing IEEE Std 1505™

*IMPORTANT NOTICE: IEEE Standards documents are not intended to ensure safety, health, or environmental protection, or ensure against interference with or from other devices or networks. Implementers of IEEE Standards documents are responsible for determining and complying with all appropriate safety, security, environmental, health, and interference protection practices and all applicable laws and regulations.*

*This IEEE document is made available for use subject to important notices and legal disclaimers. These notices and disclaimers appear in all publications containing this document and may be found under the heading “Important Notice” or “Important Notices and Disclaimers Concerning IEEE Documents.” They can also be obtained on request from IEEE or viewed at <http://standards.ieee.org/IPR/disclaimers.html>.*

## 1. Overview

### 1.1 Scope

The scope of this standard is the definition of a pin map utilizing the IEEE 1505™<sup>1</sup> receiver fixture interface (RFI). The pin map defined within this standard shall apply to military and aerospace automatic test equipment (ATE) testing applications.

---

<sup>1</sup> Information on references can be found in Clause 2.

## 1.2 Purpose

Standardization of a common input/output (I/O) will enable the interoperability of IEEE 1505 compliant interface fixtures [also known as *interface test adapters* (ITA), *interface devices* (IDs), or *interconnecting devices* (ICDs)] on multiple ATE systems utilizing the IEEE 1505 RFI.

## 1.3 Statement of the problem

### 1.3.1 U.S. Government guidance

From 1980 to 1992, the U.S. Department of Defense (DoD) investment in field, depot, and factory automatic test systems (ATS) exceeded \$35 billion with an additional \$15 billion for associated support. Most of this test capability was acquired as part of individual weapon system procurements. This led to a proliferation of different custom equipment types with unique interfaces. Recent policy decisions have changed the direction of the purchase of test equipment towards a standards based approach with both hardware and software critical interface requirements.

The U.S. DoD Instruction 5000.2-R1 ATS Policy states: “ATS capabilities shall be defined through critical hardware and software elements” (see [B2]<sup>2</sup>). This policy however, did not define these critical elements. The Critical Interfaces Project was created to define critical ATS elements.

### 1.3.2 Critical Interfaces Project

The Factory-to-Field Integration of Defense Test Systems Project (commonly referred to as the *Critical Interfaces Project*) was started in the latter part of 1995. The Critical Interfaces Working Group (CIWG) within the Joint-Service ATS Research and Development Integrated Product Team (ARI) was established to perform the project. The ATS Executive Agent Office (EAO) has provided project management and coordination among the Air Force, Army, Marine Corps, and Navy participants. In addition, many industry representatives have participated. The CIWG published their findings in the Automatic Test System Critical Interfaces Report [B1] and this report served as the basis for the development of the RFI architecture and subsequent specification.

The objective of the Critical Interfaces Project was to demonstrate the feasibility of reducing the cost to re-host test program sets (TPSs) and increase the interoperability of TPS software among the military services by using standardized interfaces.

Interfaces that offer the potential to achieve this objective are deemed critical. Potential savings will be quantified through demonstration. The Automatic Test System Critical Interfaces Report [B1] is maintained by the ATS EAO and provides guidance to DoD ATE acquisition programs. This document also addressed the requirements of DoD Regulation 5000.2-R1 [B2] and assisted in migrating the DoD designated tester families towards a common solution. The Hardware Interfaces (HI) Subcommittee of the IEEE Standards Coordinating Committee on Test and Diagnosis for Electronic Systems (SCC20) applied the recommendations of the report as it related to the RFI, to the extent that the current RFI standard is in full compliance with the report.

### 1.3.3 CTIWG guidance recommendations

During the Common Test Interface Working Group (CTIWG) October 2003 meeting, the DoD provided the following recommendations as guidance for the Working Group’s success:

---

<sup>2</sup> The numbers in brackets correspond to those of the bibliography in Annex B.

- a) Identify a modular/scaleable interface
- b) Allow use of different size ID/fixture on the same general purpose interface (GPI)
- c) Ensure TPS hardware compatibility as interface grows
- d) Provide legacy system support
- e) Provide a transition path to support legacy TPS hardware
- f) Adhere to an open architecture system
- g) Built to one specification
- h) Multiple sources
- i) Non-proprietary design and components
- j) Ensure capabilities that provision for growth and special requirements
- k) Provide room for future expansion and TPS requirements
- l) Support and Promote the use of commercial-off-the-shelf (COTS) interconnect components
- m) Use industry standard connector technology

### 1.3.4 CTIWG legacy test program set support

In support of these recommendations, the CTI architecture shall assure past legacy and future TPS *plug and play* compatibility between defense agencies and defense-aerospace suppliers. Areas addressed by the CTIWG include:

- a) Pin mapping
- b) Scalability
- c) TPS legacy support
- d) Connector parametric (dc to light)
- e) Reliability and maintainability
- f) Physical
- g) Switching
- h) Design-to-cost factors

## 2. Normative references

The following referenced documents are indispensable for the application of this document (i.e., they must be understood and used, so each referenced document is cited in text and its relationship to this document is explained). For dated references, only the edition cited applies. For undated referenced, the latest edition of the referenced document (including any amendments or corrigenda) applies.

IEEE Std 1505-2006, IEEE Standard for Receiver Fixture Interface.<sup>3, 4</sup>

---

<sup>3</sup> IEEE publications are available from the Institute of Electrical and Electronics Engineers, 445 Hoes Lane, Piscataway, NJ 08854, USA (<http://standards.ieee.org/>).

<sup>4</sup> The IEEE standards or products referred to in Clause 2 are trademarks owned by the Institute of Electrical and Electronics Engineers, Incorporated.

## 3. Definitions, acronyms, and abbreviations

### 3.1 Definitions

For the purposes of this document, the following terms and definitions apply. *The Authoritative Dictionary of IEEE Standards Terms* [B5] should be referenced for terms not defined in this clause.

**3.1.1 pin map:** The data table and explanatory text that provides the assignment of electrical characteristics or instrument I/O to specific pins.

### 3.2 Specification terms

The specification terms used throughout this standard are described as follows.

**Rule:** Rules *shall* be followed to ensure compatibility to the standard. A rule is characterized by the use of the words *shall* and *shall not*. These words are not used for any other purpose other than stating rules.

**Recommendation:** Recommendations consist of advice to applicants that will affect the usability of the final device. Discussions of particular hardware to enhance throughput would fall under a recommendation. These should be followed to avoid problems and to obtain optimum performance.

**Suggestion:** A suggestion contains advice that is helpful but not vital. The reader is encouraged to consider the advice before discarding it. Suggestions are included to help the novice designer with problematic areas of the design.

**Permission:** Permissions are included to clarify the areas of the specification that are not specifically prohibited. Permissions reassure the reader that a certain approach is acceptable and will cause no problems. The word *may* is reserved for indicating permissions.

**Observation:** Observations spell out implications of rules and bring attention to things that might otherwise be overlooked. They also give the rationale behind certain rules, so that the reader understands why the rule must be followed.

### 3.3 Acronyms and abbreviations

ACPS	alternating current power supply
ADC	analog-to-digital converter
AI	analog instrument
AM	amplitude modulation
ATE	automatic test equipment
ATS	automatic test system
AWG	arbitrary waveform generator, American wire gauge

CAL	calibration
CAN	controller-area network
CASS	Consolidated Automated Support System <sup>5</sup>
CH	channel
CIWG	Critical Interfaces Working Group
CLK	clock
COTS	commercial-off-the-shelf
CSW	coax switch
CTI	common test interface
DAC	digital-to-analog converter
DAS	display analyzer-simulator
DCPS	direct current power supply
DMM	digital multi-meter
DoD	U.S. Department of Defense
DTC	design-to-cost
ECL	emmitter-coupled logic
ESTS	Electronic Systems Test Set <sup>6</sup>
ETE	end to end
EXT	external
freq	frequency
FTIC	frequency time interval counter
GND	ground
GPI	general purpose interface
HPL	high-power load
IAIS	improved avionics intermediate shop
ICD	interconnecting device

---

<sup>5</sup> US Navy Tester, AN/USM-636 (V).

<sup>6</sup> US Air Force Tester, AN/GSM-397 (V).

ID	interface device
IFTE	Integrated Family of Test Equipment <sup>7</sup>
Instr	instrument
I/O	input/output
ITA	interface test adapter
JTAG	Joint Testability Action Group
LCC	life-cycle costs
LFC	low-frequency calibrator
LM-STAR <sup>®</sup>	Lockheed Martin Star <sup>8</sup>
LPL	low-power load
LXI	LAN extensions for instrumentation
max	maximum
min	minimum
MOD	modulation
MoD	Ministry of Defense (UK)
MOD SRC	modulation source
MRK	marker
MTA	microwave transition analyzer
MTBF	mean time between failures
MUX	multiplexer
NOM	nominal
OCD	open-collector driver
ORD	Operational Requirements Document
PAM	phase-angle modulation
PCI	Peripheral Component Interface

---

<sup>7</sup> US Army Tester, AN/USM-632 (V)3.

<sup>8</sup> LM-STAR is a registered trademark of Lockheed Martin Corporation. This information is given for the convenience of users of this standard and does not constitute an endorsement by the IEEE of these products. Equivalent products may be used if they can be shown to lead to the same results.



PECL	positive emitter-coupled logic
PGEN	pulse generator
PH	phase
PM	pulse (or phase) modulation, power meter
Prog	programmable
PS	power supply
PSW	power switch
PXI	PCI Extensions for Instrumentation (compact PCI format)
RAF	Royal Air Force
ResLoad	resistive load
RF	radio frequency
RFI	receiver fixture interface
RSIA	raster stroke image acquisition
SAMe	sistema automatico de mantenimiento estandar
Spec An	spectrum analyzer
STA	system trigger assembly
Std	Standard
Sync	synchronizer
TETS	Third Echelon Test System <sup>9</sup>
TPS	test program set
Trig	trigger
TSP	twisted shielded pair
TTL	transistor-transistor logic
UBIC	universal bus interface controller
USB	Universal Serial Bus
UUT	unit under test
VGA	Versatile Graphics Adapter

---

<sup>9</sup> US Marine Tester, AN/USM-657 (V)1, (V)2, (V)3.

VME	versa-module extended
VXI	VME extended for instrumentation

## 4. Common test interface requirements

### 4.1 Introduction

The following subclauses and illustrations describe the requirements for this standard, IEEE Std 1505.1-2008, to support military/aerospace test requirements. This information is supplemental and not stand-alone and shall coexist with that presented in the IEEE Std 1505 RFI specifications, Clause 1 through Clause 6.

The IEEE 1505.1 standard for the use of IEEE 1505 RFI to support military/aerospace test requirements represents a higher order subset of cost/physical/signal performance requirements to meet specific industry and defense agency goals of a common test interface (CTI). These high order requirements expand on the previously defined RFI: (a) framework; (b) connector modules and respective contacts; to meet objectives for: (c) a common scalable pin map configuration; (d) switching; and (e) legacy ATS transitional device for Third Echelon Test System (TETS), Consolidated Automated Support System (CASS), Integrated Family of Test Equipment (IFTE), and others as deemed necessary by the cognizant agencies. This is intentionally done to standardize the footprint and assure mechanical and electrical interoperability between past and future ATS.

### 4.2 CTI open system requirements

#### 4.2.1 Government “open system” policy

On 29 November 1994, the Honorable Paul G. Kaminski, Under Secretary of Defense for Acquisition and Technology, directed acquisition executives in the DoD to use “open systems” specifications and standards (electrical, mechanical, thermal, etc.), for acquisition of all weapon systems electronics to the greatest extent practical. The Open Systems Joint Task Force (OS-JTF) was formed in September 1994 to: “Sponsor and accelerate the adoption of open systems in weapons systems and subsystems electronics to reduce life-cycle costs (LCC) and facilitate effective weapon system intra- and interoperability.”

#### 4.2.2 CTI “open” architecture

**Rule 4.2.2:** An open standard CTI *architecture* shall identify components, the relationship between components, and the rules for the architecture’s composition.

**Recommendation 4.2.2:** Typical guidelines for addressing the CTI architecture should include:

- a) Define and describe a system architecture that is traceable to the Operational Requirements Document (ORD).
- b) A preferred architecture is modular, hierarchical and layered, and is based on open standards at its interfaces.
- c) Selection of an architecture shall be a cooperative process between government and industry.
- d) Specify key performance attributes of system building blocks including internal interface standards.

- e) Where a new system is contemplated, consensus among potential contractors and their key suppliers on application of widely accepted standards is desirable.
- f) Identify aspects of the program that might limit the use of an open systems approach.
- g) Determine the level at which the architecture will be defined for the system.
- h) Architecture approach resulting from a system engineering process shall be linked to a business case analysis.
- i) Decisions about architecture shall be linked to performance, LCC, schedule, and risk.
- j) Identify opportunities for reuse of hardware and software configuration items and dependence upon interfaces.

### 4.3 CTI cost requirements

**Recommendation 4.3a:** Fundamental to the implementation of the CTI recommended practice should be the paramount need to address design-to-costs (DTC) and LCC attributed to test interface and TPS requirements.

**Recommendation 4.3b:** CTI should improve the test acquisition process by creating a competitive multi-vendor environment that provisions common module components that can be procured as COTS, at pricing that benefits from industry economics-of-scale production/quality processes, and improved time-to-market availability.

**Recommendation 4.3c:** CTI should meet advanced functional and technological needs through shared industry R&D, multi-functional/virtual modules that can be replicated, distributed, and reconfigured to meet a broad set of applications without customization. Extend legacy system life through technology insertion of plug and play enhancements based upon standardized infrastructure, and related cost-avoidance of ATS obsolescence.

**Recommendation 4.3d:** CTI should minimize configuration variations and related software customization and adjustments between unique test assets, integration methods, and signal routing schemes.

**Recommendation 4.3e:** CTI should promote cooperative design, design reuse, shared design data models, automation in software development, rehostability and portability of TPSs, implementation of lessons learned, and enhance long-term support between vendors, integrators and users. Standards also promote common fabrication processes, signal routing schemes, canned solutions that could reduce TPS engineering integration time and cost.

### 4.4 Vertical integration test support requirements

**Recommendation 4.4:** The implementation of the CTI/RFI standard as common *vertical integrated test support* through the product cycle and various maintenance levels assures the greatest benefits of common system implementation and cost savings. Specific benefits include the shared development/manufacturing of ATS and TPS assets, enhanced TPS verification and refinements, and transitional improvements in lessons learned, hands-on training and asset management.

## 4.5 CTI configuration/interoperability requirements

**Rule 4.5:** CTI *pin map requirements*, as defined by *general pin map requirements* in Annex A, and subsequent detailed *CTI pin map input/output (I/O) configuration*, shall be implemented to assure test interface interoperability between agencies and ATS configurations.

**Recommendation 4.5:** A common CTI pin map configuration has been recommended across government multi-agencies, to stimulate greater use of common assets, which reduces proliferation and support duplication. By satisfying interoperability requirements between government agencies TPS development, deployment and asset duplication can be eliminated and related weapon system support enhanced.

## 4.6 Maintainability/end-user support requirements

**Rule 4.6:** The general pin map requirements in Annex A, and subsequent detailed CTI pin map I/O configuration, as part of this IEEE 1505.1 CTI document, shall be maintained/upgraded through IEEE standards revision processes.

**Recommendation 4.6:** The CTI implementation within industry and the government, utilizing standard product configurations, multi-vendor interchangeable parts, calibration, and maintenance support is recommended.

**Observation 4.6:** Applying common CTI products to ATS and CTI fixture deployment would dramatically reduce duplicative requirements for unique system development, validation, production, deployment, configuration product management, and long-term support. This approach would further enhance asset availability/uptime mean time between failures (MTBF), calibration/spares consolidation, and mean-time-to-repair (MTTR) results. Users could also benefit from common maintenance practices, tooling, and training costs. CTI implementation would also focus product management/feedback on a smaller number of unique installed systems, their related failures/lessons learned, and iterative improvements, resulting in improved reliability, less obsolescence, and longer life cycles.

## 4.7 Scalable architecture requirements

### 4.7.1 Overview

**Rule 4.7.1:** CTI shall support modular and scaleable concepts as illustrated in Figure 1. Based upon the IEEE 1505 RFI standard, CTI shall support upward scalable compatibility without modification or added extensions of a low-end (4-slot CTI configuration), and a mid-sized (20-slot CTI configuration), to a high-end (29-slot CTI configuration) test system capability.

**Observation 4.7.1:** Scalability—“Serves to minimize or eliminate the costs of fixturing by scaling the requirements to minimum framework and related pin map configuration. This minimizes the size, storage requirements, and complexity of fixturing, as well as related receiver and fixture(s) costs, to only what is necessary to interface the unit under test (UUT) to the ATS (e.g., a cable assembly can be plugged into the receiver without a fixture box being applied). This also permits an avionics board manufacturer to develop a compatible TPS for factory test and allow the Government to utilize that same fixture on the high-end depot tester without modifications/adapters. Such capabilities demand that the mechanism support engagement actuators at incremental points to pull smaller fixtures into the receiver.”

### 4.7.2 General building block architecture

**Rule 4.7.2:** CTI shall support a scalable building block architecture with common I/O pin map that remains upwardly compatible with matched connector/contact configuration and scalable application levels described in Table 1.<sup>10</sup>

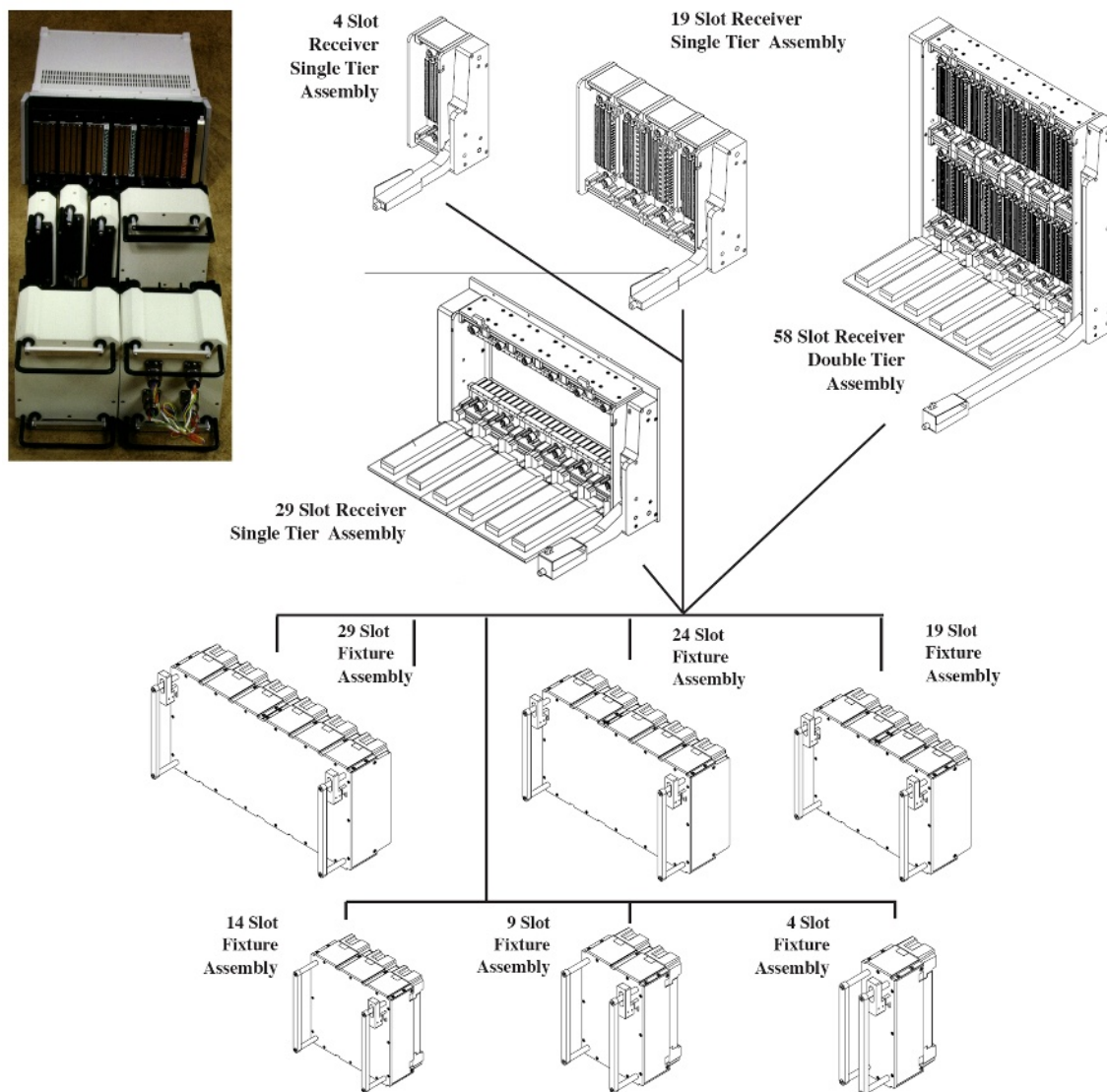

**Figure 1—CTI system receiver modular scalable framework architecture**

<sup>10</sup> Notes in text, tables, and figures of a standard are given for information only and do not contain requirements needed to implement this standard.

## 4.8 Physical framework requirements

### 4.8.1 IEEE 1505 RFI standard compliance

**Rule 4.8.1:** The CTI shall be fully compliant with IEEE Std 1505 RFI standard framework specifications, Clause 5, expandable to two tiers, to a maximum of 29 slots per tier (26 slots usable for connector mounting, see Figure 2 and Figure 3).

**Table 1—CTI building block suggested configuration**

<b>Worse case: High-end test system application—26 connector slots/3 blanks</b>	
Signal contacts:	3200 pos, 0-3A/200 pos module
Lo / hi power contacts:	270 pos 23 A / 152-59 pos
Lo / hi coax contacts:	363 pos 3 GHz / 152-59 pos
<b>Typical: Mid-range test system application—18 connector slots/2 blanks</b>	
Signal contacts:	2800 pos, 0-3 A/200 pos module
Lo / hi power contacts:	211 pos 23 A / 152-59 pos
Lo / hi coax contacts:	59 pos 3 GHz / 152-59 pos
<b>Basic: Low-end test system application—4 connector slots</b>	
Signal contacts:	600 pos, 0-3 A/200 pos module
Lo / hi power contacts:	59 pos 23 A / 152-59 pos
Lo / hi coax contacts:	0 pos 3 GHz / 152-59 pos
NOTE—pos = position (interchangeable with term <i>contact</i> in this context)	

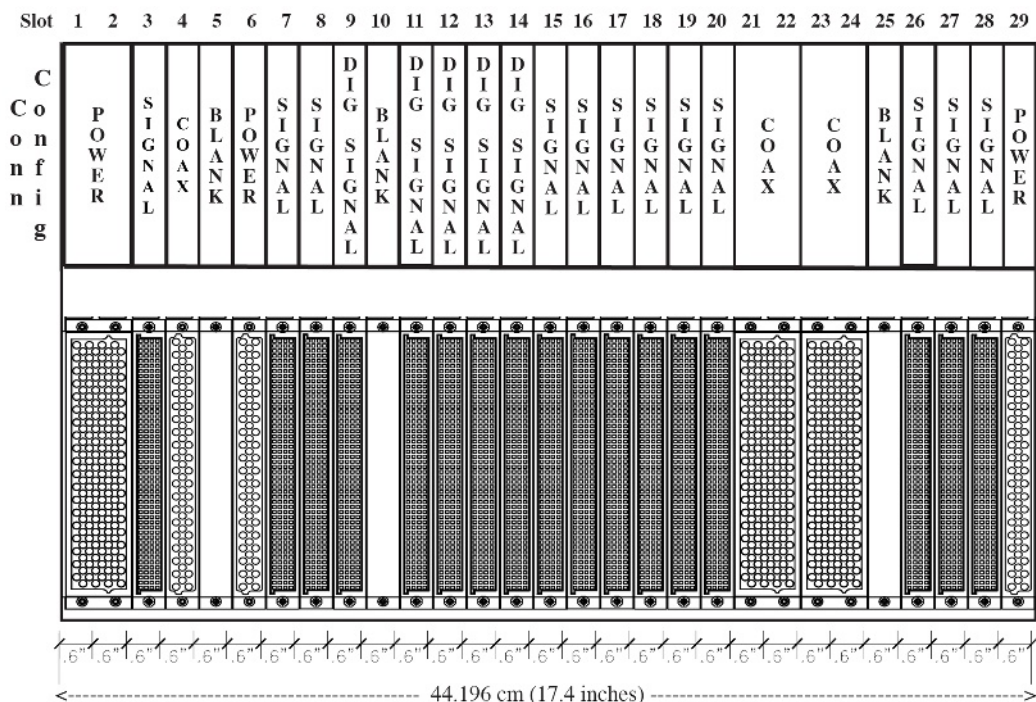

**Figure 2—CTI system 29-slot receiver connector configuration**



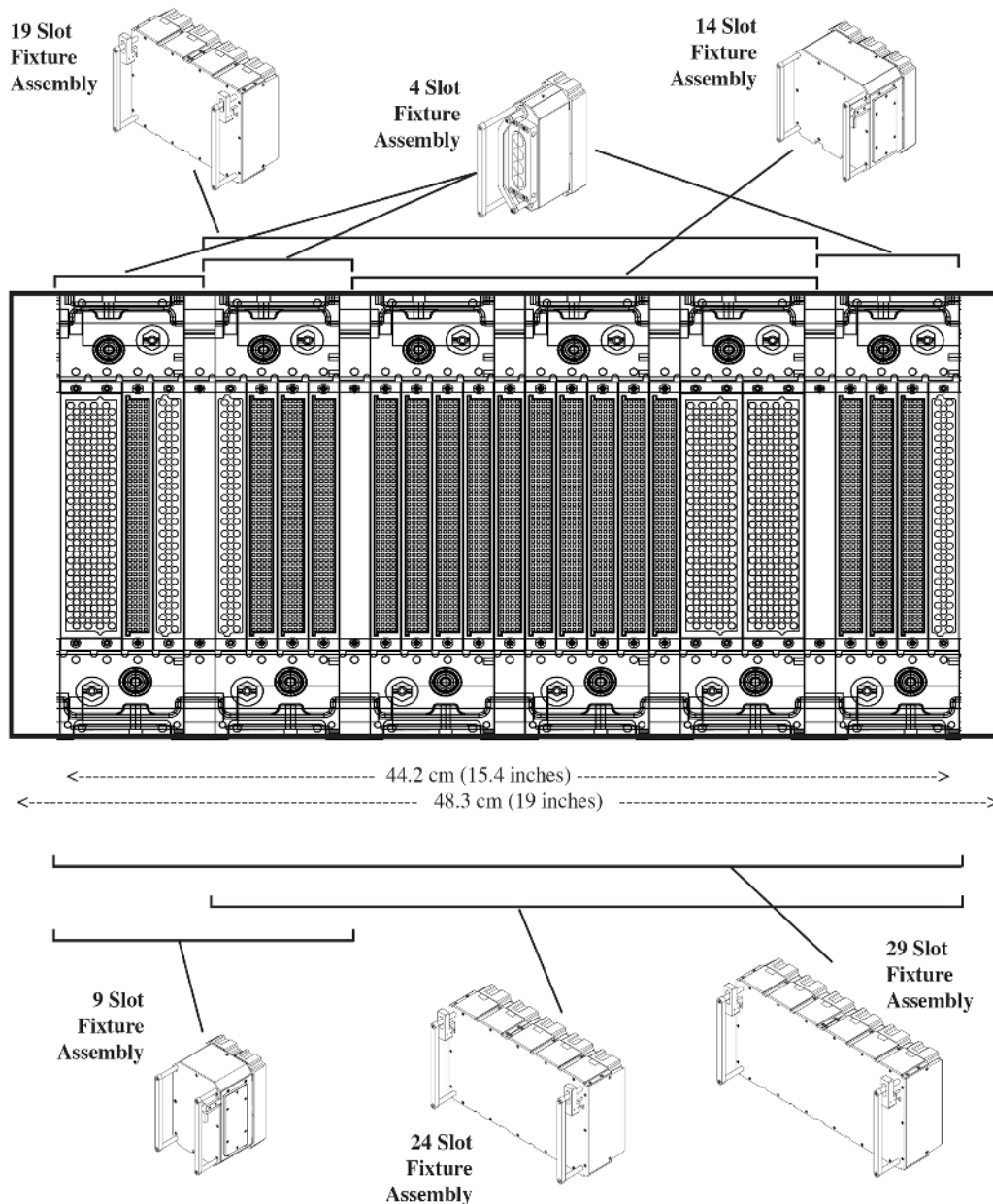

**Figure 3—CTI system configuration to fixture options**

#### 4.8.2 CTI modular combination framework design

**Rule 4.8.2:** Under IEEE Std 1505 *combination framework specification* (detailed in the RFI framework specification, Clause 5), the CTI *framework* shall provision three (3) blanks at slot 5, 10, and 25 to provision a 1.524 cm (0.6 in) spacing for the protective shrouds of two adjoining fixtures.

**Permission 4.8.2:** Combinational framework requirement can be implemented in any of two methods: (a) combining *segmented and continuous framework* (illustrated in Figure 6), to form a 29-slot configuration

made up of three (3) segmented 5.6 cm (3 in) wide frames, with four (4) connector slots each, and one (1) continuous 22.9 cm (9 in) wide frame, that supports fourteen (14) connector slots that supports frame/blank spacing at slots 5, 10, 25; or (b) modifying a 29-slot continuous framework (illustrated in Figure 5 and Figure 6), to provision three blanks at slots 5, 10, 25.

#### 4.8.3 CTI receiver footprint/scaleable requirements

**Rule 4.8.3a:** CTI receiver framework footprint shall be a scaleable combinational implementation that can be incremented from the smallest footprint of a segmented framework of four (4) connector slots, and expandable to 29 slots by adding segmented and/or continuous framework intervals, while maintaining downward compatibility with any smaller fixture increments (26 slots for connectors and 3 slots for shroud spacings). Either of the framework implementations can be reduced to any interval segmented at slot 5, 10, and 25 with combinations that can support 4, 8, 14, 18, or 22 slots usable for connector mounting. All connector configurations shall satisfy the IEEE Std 1505 framework/connector specifications, Clause 5 and Clause 6, and CTI pin map I/O configuration and general pin map requirements, Annex A.

**Rule 4.8.3b:** Physical footprint of the CTI *receiver framework* shall be in accordance with framework specification, Clause 5, that describes receiver framework under IEEE Std 1505 segmented and continuous framework layouts, as the examples in Figure 4 and Figure 6 further illustrate. Although the receiver drive system implementation is supplier dependent, the CTI receiver mechanical drive system shall not extend beyond the dimensional envelope of a standard 48.3 cm (19 in) rack width or height of 35.6 cm (14 in) (including handle height);

**Rule 4.8.3c:** The CTI specification permits integrators or users to add incremental receiver framework, anytime, to satisfy any mix of fixture requirements, as shown in Figure 1 and Figure 3, that includes multiple tier increments (two tier shown in Figure 1), in accordance with the CTI pin map I/O configuration and general pin map requirements, Annex A.

**Rule 4.8.3d:** Overall physical size of each CTI *receiver tier*, including drive assemblies, shall not exceed standard 19 in equipment rack width in accordance with EIA/ECA-310-E (2005) [B3], or 35.56 cm (14 in) height, or protrude from the mounting plate more than 8.89 cm (3.5 in).

#### 4.8.4 CTI receiver physical weight requirements

**Rule 4.8.4:** Physical weight of the CTI receiver framework shall not exceed a maximum of 5.63 kg (8.0 lb) per 7.62 cm (3 in) frame interval and 21.8 kg (48.0 lb) for each CTI 29-slot tier, including fully populated connector modules and the engagement mechanism.

#### 4.8.5 CTI mechanical engagement requirements

**Rule 4.8.5:** The CTI *receiver mechanical engagement system* shall be in accordance with framework specification, IEEE Std 1505, Clause 5, and provide sufficient mechanical advantage to overcome the physical mating insertion force of a fully-populated interface and the cantilevered fixture weight requirements, and apply sufficient mechanical advantage to assure a 15.9 kg (35 lb) of handle force is not exceeded.



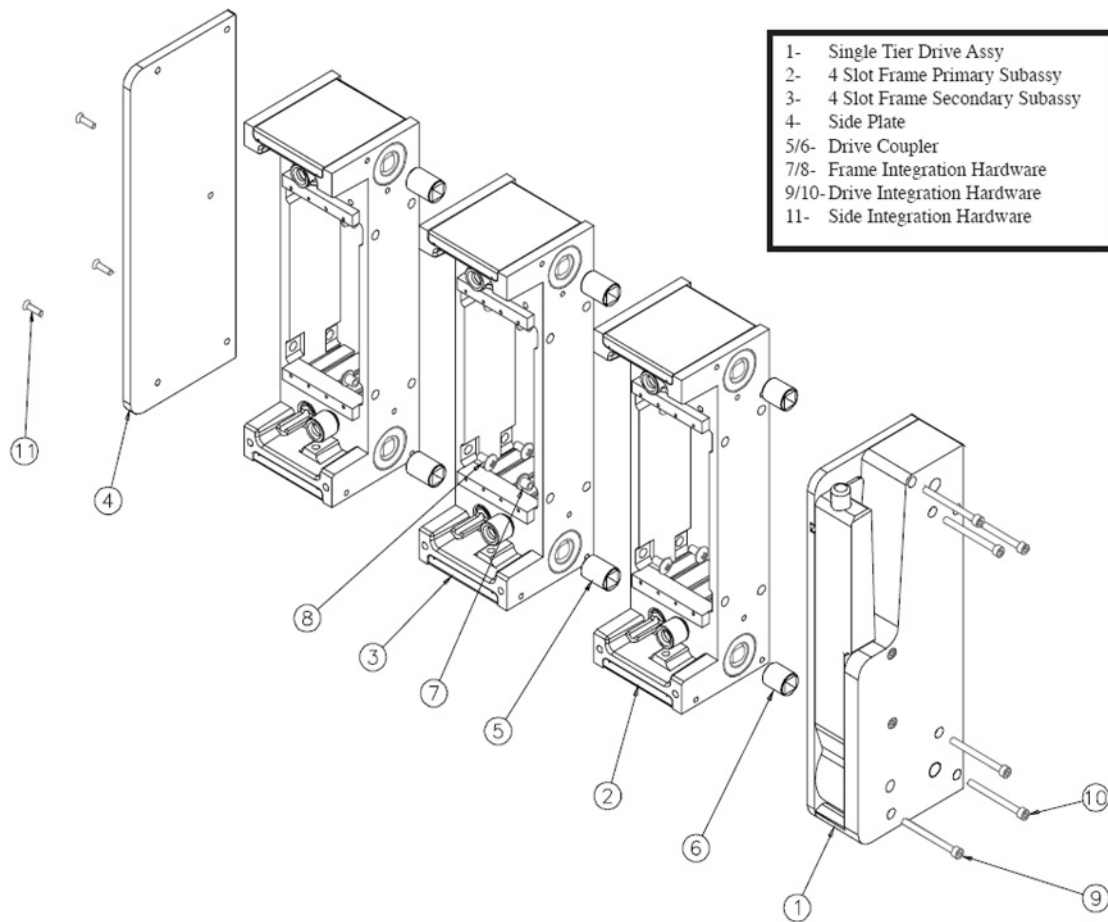

**Figure 4—IEEE 1505 receiver segmented framework example**

#### 4.8.6 CTI fixture weight requirements

**Rule 4.8.6:** Each CTI receiver 4-slot *frame increment* shall support a maximum static fixture weight (fixture fully engaged to receiver) of 4.54 kg (10 lb) cantilevered at 38.1 cm (15 in) from receiver mating interface while meeting cycle life, interface insertion force, and electrical parametric requirements. In increments of 4.54 kg (10 lb) per 7.62 cm (3 in) frame interval, a CTI 29-slot receiver with six frame intervals shall support a maximum of 22.68 kg (50 lb) at 38.1 cm (15 in).

NOTE—Implementers/users shall provide additional safety support to assist operators during lift, and prevent injury or damage to equipment, when engaging/disengaging heavy fixture applications.

#### 4.8.7 Oversized fixture keep-out area

**Rule 4.8.7:** Fixture manufacturers that offer large (oversize) fixture footprints shall not intrude on the dimensional areas annotated in Figure 5.

**Observation 4.8.7:** The area to the right is reserved for operation of the engaging handle. The area below the fixture is reserved for fixture support facilities.

**CAUTION**  
Manufacturers should be cognizant of cantilevered weight and other surrounding interference factors that may impact implementation when standard footprints are exceeded.

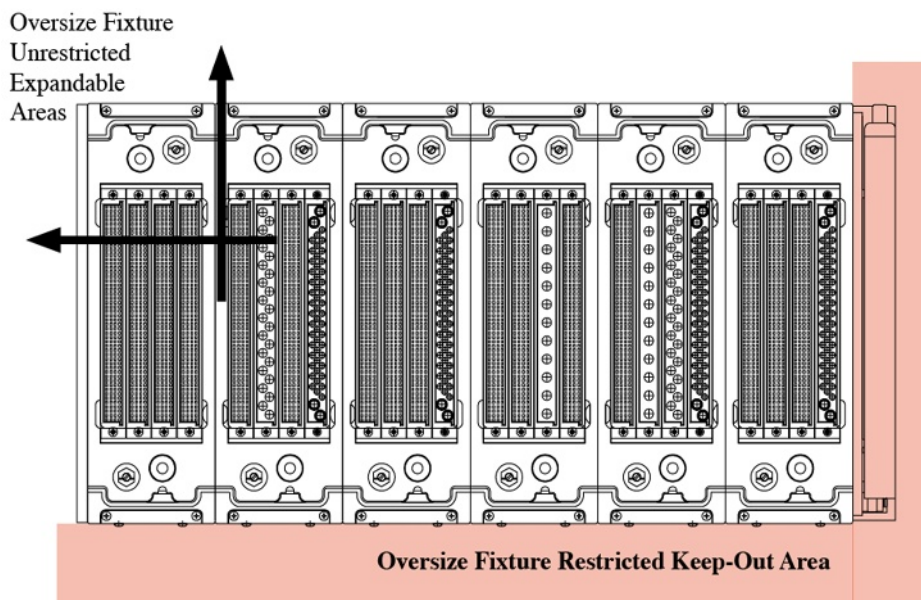

**Figure 5—Fixture (ITA) footprint restricted areas**

#### 4.8.8 Transportability/mobility requirements

**Rule 4.8.8:** CTI shall meet transportability/mobility requirements per the IEEE Std 1505 RFI environmental/quality specifications, defined in Clause 4 and Clause 5 of the standard. A fully assembled CTI (framework, connector modules, contacts, and engagement mechanism) shall withstand a 5 ms of 49 m/s for shock drop test.

**Observation: 4.8.8:** The intent of the drop test is to ensure the assembled interface does not deform or otherwise become unusable if it is “dropped” during assembly or repair. The condition of this test includes the interface as a stand-alone object, impacted on all corners and faces at a 5 ms of 49 m/s for shock drop test force.

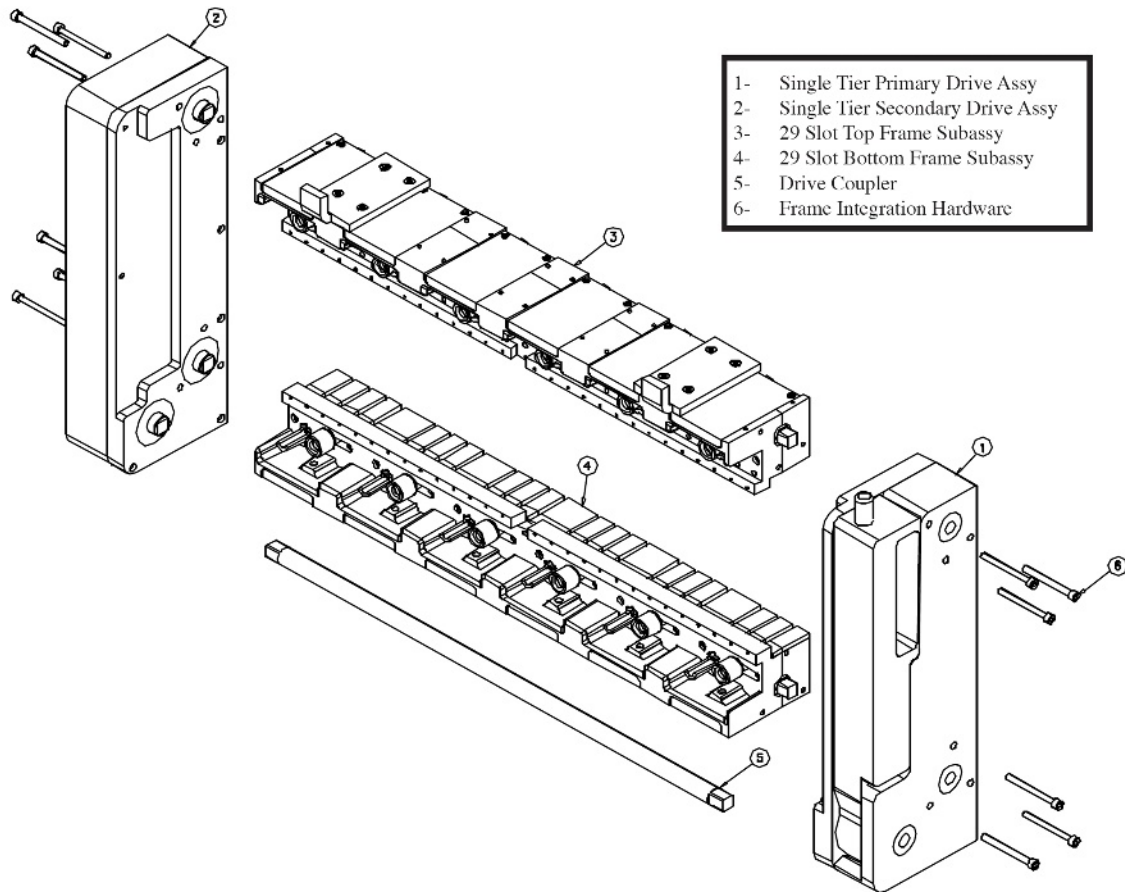

Figure 6—IEEE 1505 receiver continuous framework example

## 4.9 Reliability requirements

### 4.9.1 Repeatability/reproducibility/interchangeability

**Rule 4.9.1:** CTI design shall conform to dimensional and functional requirements defined in IEEE Std 1505 RFI environmental/quality specifications, described in Clause 5 and Clause 6, in order to assure component part interchangeability/intermateability and interoperability between components from multiple vendors. Component parts shall remain “operational” through life of the program. Any part changes that affect form, fit, or function cannot obsolete existing parts.

### 4.9.2 Mean time between failures requirements

**Rule 4.9.2:** CTI components shall be designed and produced to perform without failure between established durability/life-cycle requirements. Failures shall be assessed to determine cause and corrective actions. MTBF data for the CTI components shall be calculated in accordance with MIL-HDBK-217 [B21].

### 4.9.3 Durability and cycle life

**Rule 4.9.3:** Durability and cycle life for CTI receiver/fixture mechanism shall have a minimum durability rating of 25 000 cycles. Connector module contacts shall have a minimum durability rating of 10 000 cycles. Cycle limits are considered end of life requiring replacement of wearable items. Manufacturers shall validate conformance to this specification in accordance with the IEEE Std 1505 RFI qualification requirements, Clause 4, cycle testing, and per framework specifications, Clause 5.

## 4.10 CTI connector footprint/parametric requirements

### 4.10.1 IEEE 1505 RFI standard compliance

**Rule 4.10.1a:** CTI shall be compliant with the IEEE Std 1505 RFI standard connector specifications, Clause 6, that establishes the Eurocard DIN standard connector footprint as the basis of CTI architecture.

**Observation 4.10.1:** Both commercial and ruggedized versions (under MIL-C-55302/179-180 [B20]) were available in a 200-pin, 4-row connector by two of the three primary interface suppliers. Signal module meets the highest levels for open system, low-cost, performance, COTS acceptance, and level of applicability, receiving more than 25% higher grade over any of the other connectors reviewed.

**Rule 4.10.1b:** CTI shall implement three DIN connector types: (a) signal; (b) power; and (c) RF coax; as defined in IEEE Std 1505 RFI standard connector specifications, Clause 6, and related connector specifications, Clause 7 through Clause 12.

### 4.10.2 CTI requirements for compliance

**Rule 4.10.2:** Suppliers of systems shall state their degree of compliance to IEEE Std 1505.1 using the definitions of compliance in 4.10.2.1 and 4.10.2.2.

#### 4.10.2.1 Mechanical compliance

**Rule 4.10.2.1:** To meet this criteria, a manufacturer shall at the minimum supply an IEEE 1505 RFI compliant interface that conforms to a connector per slot type that matches the configuration shown in Figure 2. That is, the power connector is used in slot ½, the 200-pin signal module in slot 3, etc.

**Observation 4.10.2.1:** This level of compliance only ensures that physical connector damage will not result from installing a fixture (ITA/ID) from one minimum level compliant system onto a different minimum level compliant system's receiver. It does *not* ensure that the proper signals will be routed.

#### 4.10.2.2 Full compliance

This is the highest degree of compliance and requires full slot-by-slot mechanical and electrical compatibility for the stated compliance categories defined as follows.

**Rule 4.10.2.2a:** To state full compliance, a manufacturer shall meet all the requirements for the signals for each slot as identified in Annex A, except for the columns labeled "Recommended attributes." Non-populated modules should be blank (e.g., if block is "blank," it can be keyed normally; if block has different pin out, it shall be keyed differently). Both the full compliance and the following category shall be stated.

The following are the defined categories:

- a) Category 1—This is defined as mechanically and electrically compliant with the Annex A slots 6 through 9. This is the basic *stimulus-measurement* section of the pin map.
- b) Category 2—This is defined as mechanically and electrically compliant with Annex A slots 1 through 9. This is the basic stimulus-measurement plus power supplies and switching of the pin map.
- c) Category 3—This is defined as mechanically and electrically compliant with Annex A slots 6 through 24. This is the basic stimulus-measurement plus digital, switching, and additional analog of the pin map.
- d) Category 4—This is full slot compliance (mechanical and electrical) for slots 1 through 24 of the Annex A pin map.
- e) Category 5—This is full slot compliance (mechanical and electrical) for all 29 slots of the Annex A pin map.

NOTE—Partially compliant approaches shall rotate keys 180 degrees to insure that physical and/or electrical damage is not incurred.

**Observation 4.10.2.2:** This level of compliance ensures both mechanical compatibility between systems *and* electrical signal compatibility/interoperability between systems for the slots included in the categories. The categories represent scalable increments based on the segmented architecture and the electrical signals included in the scalable options.

**Permission 4.10.2.2a:** Pins may also have lesser or higher capability as identified in Annex A tables as long as the pin mapping of Annex A is met and the capability is of the same/similar functionality. For example, an identified dc power supply (DCPS) capability identified in Annex A should be matched with a DCPS, not an ac supply.

**Permission 4.10.2.2b:** The designer of a compliant system is allowed to implement capability identified in Annex A with non-classical instruments.

### 4.10.3 Standardized keying

A standardized keying arrangement is required to support the compliant interfaces. Each 4-slot section of the IEEE 1505 RFI interface has a top and bottom key as shown in Figure 7. Each key is set in a hexagonal socket that allows one of six rotational positions. Therefore, with the top and bottom key being independently variable, the keying of one 4-slot segment can have one of 36 different keying arrangements.

**Rule 4.10.3a:** Systems (receivers and ITAs) that implement a mechanically or fully compliant interface as defined in 4.10.2 and subparagraphs shall implement the keying as shown in Figure 7.

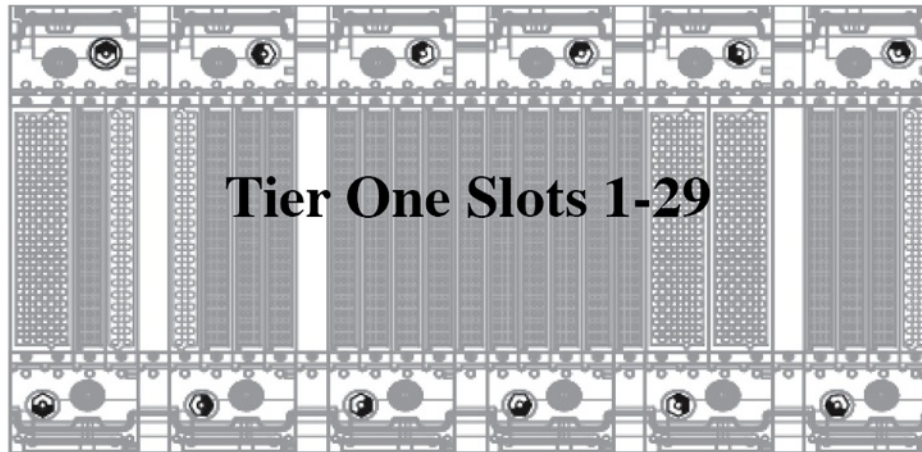

**Figure 7—Standardized keying for compliant systems (receiver view)**

**Rule 4.10.3b:** Systems that have segments that are non-compliant per the definition of 4.10.2 shall implement a different keying option. The option used shall *not* duplicate any of the keying options shown for a compliant interface for any section. The goal is to *prevent* any ability to mount a compliant ITA on any non-compliant receiver or a non-compliant ITA on a compliant receiver.

#### **4.10.4 Population policy**

**Rule 4.10.4a:** A test system developer shall follow a set order of precedence in the selection of test assets and the associated pins from the pin map. The following process shall be followed:

- a) Identify an unused test asset/instrument that meets the *minimum* test requirements.
- b) If the asset/instrument is part of a group of like-capability assets, use the lowest numbered, available (unused) asset for the test.
- c) Proceed in like fashion for the entire group of similar assets
- d) If the *minimum* required capability assets become completely used (implemented) in the TPS, proceed to utilize the next highly capability asset/instrument.
- e) If this asset/instrument is part of a group, follow the same rules in which the lowest numbered is utilized first.

**Rule 4.10.4b:** A TPS developer shall follow a set order of precedence in the selection of test assets and pins from the pin map. The following process shall be followed:

- 1) Select an unused test asset/instrument that meets the *minimum* requirements for the test.
- 2) If the asset/instrument is part of a group of like-capability assets, use the lowest numbered, available (unused) asset for the test.
- 3) Proceed in like fashion for the entire group of similar assets
- 4) If the *minimum* required capability assets become completely used (implemented) in the TPS, proceed to utilize the next highly capability asset/instrument. These should also be implemented from lowest numbered asset to higher numbered asset.
- 5) If this asset/instrument is part of a group, follow the same rules in which the lowest numbered is utilized first.



**Recommendation 4.10.4:** Refer to Annex A tables for clarification of asset capabilities and how assets are numbered.

#### 4.10.5 CTI connector parametric requirements

**Rule 4.10.5:** CTI connector module with contacts shall comply with the definitions contained in IEEE Std 1505 RFI connector specifications, Clause 6, and related connector specifications, Clause 7 through Clause 12, that satisfies the respective parametric requirements defined by Table 2.

**Table 2—CTI connector module/contact module performance requirements**

<b>Signal contact/module</b>	
Operating voltage:	300 Vdc max
Operating current:	3.0 Adc continuous
Contact resistance:	10 mΩ max
Insulation resistance:	5.0 x 10e9 Ω min
Capacitance:	10 pF max
Reliability:	10 000 engagement cycles
Footprint:	025 in square pins on 0.1 in centers arranged in 4 row x 50 pin multiples
Mating force:	2.0 oz/pin max
Module footprint:	200 positions in 4 columns
<b>Power module/contact</b>	
Operating voltage:	300 Vdc max
Operating current:	23 A dc/ac rms continuous/free stdg/ambient air
Contact resistance:	5 mΩ max
Characteristic imped:	n/a
Insulation resistance:	5.0 x 10e9 Ω min
Capacitance:	10 pF max
Reliability:	10 000 engagement cycles
Contact:	Size 16 DIN requirements
Mating force:	18 oz/pin max
Module footprint:	59 positions in 3 columns, or 152 positions in 8 columns

**Table 2—CTI connector module/contact module performance requirements (continued)**

Coax module/contact	
Frequency bandwidth:	dc 3 GHz
Operating voltage:	150 V ac, rms
Contact resistance:	10 mΩ max
Voltage standing wave ratio (VSWR):	1:1.22 + 0.52 f (GHz)
RF insertion loss:	.03√f (GHz)
RF leakage:	– 90dB at 2.5 GHz
Contact resistance:	Center contact; straight 6.0 mΩ max
Crosstalk:	Less than or equal to – 90 dB to 2 GHz
Characteristic imped:	50 ± 2 Ω
Insulation resistance :	1000 MΩ min
Capacitance:	15 pF max
Reliability:	10 000 engagement cycles
Contact:	Size 16 DIN requirements
Mating force:	18 oz max
Module footprint:	59 positions in 3 columns or 152 positions in 8 columns

## 4.11 CTI pin map requirements

### 4.11.1 CTI scaleable/modular pin map configuration

**Rule 4.11.1a:** The CTI scaleable pin map configuration shall support scalability (the use of less than a full tier interface as previously discussed in 4.8.3), through the distribution of station resources as defined in CTI pin map I/O configuration and general pin map requirements, Annex A.

**Rule 4.11.1b:** The CTI configuration shall apply the five (5) connector modules: (a) signal, single slot 200 position; (b) power, single slot 59 position; (c) power, double slot 152 position; (d) RF coax, single slot 59 position; and (e) RF coax, double slot 152 position; in the configuration shown in Figure 2, and in accordance with RFI connector specification, connector specifications, Clause 7 through Clause 12 of IEEE Std 1505.

**Rule 4.11.1c:** The CTI configuration shall be implemented in intervals conforming to framework segmentation in accordance with RFI framework specification, Clause 5 of IEEE Std 1505, that supports mounting of connector types in intervals of four (4), four (4), fourteen (14), and four (4) slots, or any reduced footprint, as determined by the specific application.

### 4.11.2 CTI pin map I/O categories

**Rule 4.11.2:** The CTI connector configuration, as illustrated in Figure 2, shall be implemented in accordance with detailed CTI pin map I/O configuration and general pin map requirements, Annex A. These requirements shall be divided into several I/O parametric categories, described as follows, and distributed in scaleable segments, to assure test signal mapping is a maintained for all CTI applications.



The following describes the general pin map categories:

- a) Digital I/O
- b) Analog instrumentation
- c) Programmable ac/dc load
- d) Programmable ac/dc power supplies
- e) Bus I/O
- f) Switching implementation

#### 4.11.2.1 Digital I/O

**Rule 4.11.2.1a:** CTI shall implement a scaleable digital I/O parametric/pin map configuration in accordance with CTI pin map I/O configuration and general pin map requirements, Annex A.

**Rule 4.11.2.1b:** CTI digital I/O shall be applied utilizing Eurocard DIN/MIL-DTL-55302/180 4-row 200 position connector design specifications in accordance with IEEE Std 1505 RFI standard connector specifications, Clause 7 through Clause 12.

**Suggestion 4.11.2.1:** Digital I/O signal channel may be implemented with 200 discrete wires, 100 twisted pairs, or two pins per channel of precision point-to-point 50  $\Omega$  matched impedance wiring having a bandwidth from dc to 750 MHz to a maximum of 100 channels increments (200 pins), as necessary to meet selected ATE digital requirements.

#### 4.11.2.2 Analog instrumentation

**Rule 4.11.2.2a:** CTI shall implement a scaleable AI (AI) I/O parametric/pin map configuration in accordance with CTI pin map I/O configuration and general pin map requirements, Annex A, and subsequent requirements. CTI AI I/O shall be implemented utilizing either the CTI signal or coax connectors as subsequently described.

**Rule 4.11.2.2b:** If implemented, the CTI AI I/O shall apply Eurocard DIN/MIL-DTL-55302/180 4-row 200 position connector design specifications in accordance with IEEE Std 1505 RFI connector specifications, Clause 7 through Clause 12.

**Suggestion 4.11.2.2:** AI I/O signal channel may be implemented with 200 discrete wires, 100 twisted pairs, or two pins per channel of precision point-to-point 50  $\Omega$  matched impedance wiring having a bandwidth from dc to 750 MHz to a maximum of 100 channels increments (200 pins), or as necessary to meet selected ATE digital requirements.

**Rule 4.11.2.2c:** If implemented, the CTI AI I/O shall apply RF coaxial size 16 contact with RF coax size 16 connector module design and wiring specifications in accordance with IEEE Std 1505 RFI connector specifications, Clause 7 through Clause 12.

#### 4.11.2.3 Programmable ac/dc load

**Rule 4.11.2.3a:** CTI shall implement a scaleable programmable dc load I/O parametric/pin map configuration in accordance with CTI pin map I/O configuration and general pin map requirements, Annex A.

**Rule 4.11.2.3b:** CTI programmable dc load I/O shall be applied utilizing the CTI power connector using 23 amp contact in a 59 or 152 positions power module connector design in accordance with IEEE Std 1505 RFI connector specifications, Clause 7 through Clause 12. These contacts shall be derated to 18 A, when six or more are clustered adjacent to each other and operating simultaneously and continuously at that current level.

**Suggestion 4.11.2.3:** Discrete 23 amp pins should be implemented with 14 AWG MIL-spec (high temperature and flammable resistant) discrete or twisted pair wiring.

**Permission 4.11.2.3:** CTI programmable dc load I/O where applicable may utilize low level (current <3 A) discrete I/O signal pins using Eurocard DIN 41612 and MIL-C-179/180 5 row 200 position connector design specifications in accordance with IEEE Std 1505 RFI connector specifications, Clause 7 through Clause 12, and the CTI pin map I/O configuration and general pin map requirements, Annex A. Discrete pins may be implemented with 24 AWG discrete or twisted pair wiring.

#### 4.11.2.4 Programmable ac/dc power supply

**Rule 4.11.2.4a:** CTI shall implement a scaleable programmable dc/ac power supply I/O parametric/pin map configuration in accordance with CTI pin map I/O configuration and general pin map requirements, Annex A.

**Rule 4.11.2.4b:** CTI programmable dc/ac power supply I/O shall be normally applied utilizing the CTI power connector using 23 amp contact in a 59 or 152 positions power module connector design specifications in accordance with IEEE Std 1505 RFI connector specifications, Clause 6 and Clause 8. These contacts shall be derated to 18 A, when six or more are clustered adjacent to each other, and operating simultaneously and continuously at that current level.

**Suggestion 4.11.2.4:** Discrete 23 amp pins should be implemented with 14 AWG MIL-spec (high temperature and flammable resistant) discrete or twisted pair wiring.

**Permission 4.11.2.4:** CTI programmable dc/ac power supply I/O where applicable may utilize low-level (current <3 A) discrete I/O signal pins using Eurocard DIN/MIL-DTL-55302/179/180 4-row 200 position connector design specifications in accordance with IEEE Std 1505 RFI connector specifications, Clause 7 through Clause 12. Discrete pins shall be implemented with 24 AWG discrete or twisted pair wiring.

#### 4.11.2.5 Bus I/O

**Rule 4.11.2.5a:** CTI shall implement a scaleable bus I/O parametric/pin map configuration in accordance with CTI pin map I/O configuration and general pin map requirements, Annex A.

**Rule 4.11.2.5b:** CTI bus capability shall be applied utilizing Eurocard DIN/MIL-DTL-55302/180 4-row 200 position connector design specifications in accordance with IEEE Std 1505 RFI standard connector specifications, Clause 7 through Clause 12.

**Suggestion 4.11.2.5:** Bus I/O signal channels may be implemented with 200 discrete wires, 100 twisted pairs, or two pins per channel of precision point-to-point 50  $\Omega$  matched impedance wiring having a bandwidth from dc to 500 MHz to a maximum of 100 channels increments (200 pins), as necessary to meet selected ATE bus requirements.

#### 4.11.2.6 Switching implementation

##### 4.11.2.6.1 General requirements

These interfaces describe the hardware requirements necessary to switch stimulus, response, and power signals between the UUT and the test instrumentation. The switching may be implemented in various ways.

**Observation 4.11.2.6.1:** The combination of the switch and CTI I/O provides the ATS developer the ability to select various signal paths between the instrument and UUT. Examples of switch implementations are shown in Figure 8 as: (a) benchtop units; (b) integrated switch cards; (c) rack-mounted units; and (d) switch modules meeting published industry standards such as (but not limited to) LXI, USB, VME, VXI, and PXI.

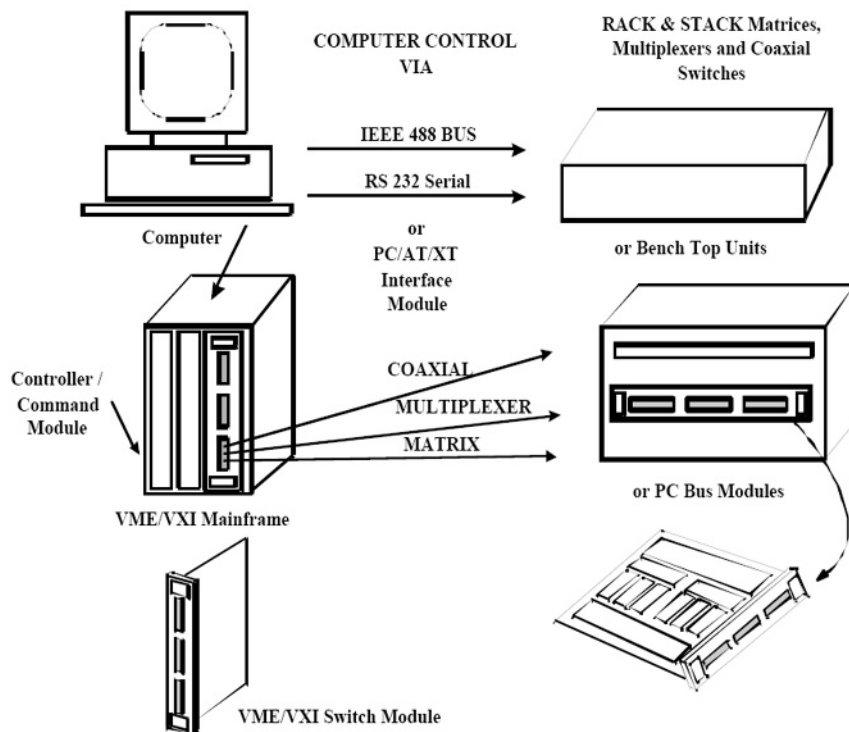

Figure 8—Switching product designs

##### 4.11.2.6.2 Switch concerns

**Observation 4.11.2.6.2:** General requirements for the switch interface, described in Table 3 and Table 4, were derived from many sources representing general industry needs, Government and commercial interests, Government open-system directives, industry technology trends, Government/aerospace test requirements previously described (functional test requirements), and test industry switch defacto standards. The CIWG and CTI Switching Task Group reviewed the widest spectrum of requirements, legacy support requirements, and other interests to assure switch elements were addressed. These requirements were extracted from the envelope of the cases reviewed. This is expected to provide capability for almost every requirement the solution will encounter. During the review process standards or products that could meet these requirements were sought. The switching philosophies considered in the analysis are the following:

- a) Switching outside ATE—This approach incorporates switching into the test fixture based on the UUT requirements. This places financial burden on the end user since switching needs to be incorporated in many test fixtures. This is a significant recurring cost.
- b) Switching in the ATE—This approach integrates the switching capability into the ATE and treats it as additional instrumentation. This simplifies test fixture design, reduces TPS cost, and places the switching under control of the ATE system software. This can be accomplished in one of two ways:
  - 1) *Internal hardwiring* of instrumentation to ATE switching. The internal approach simplifies test fixture design and implementation; however, a performance trade-off discussion resulted in providing instrument parts directly at the CTI. Costs associated with connecting the instruments to the switch are relegated to the electrical connectivity within the ATS-to-UUT interface adapter.
  - 2) *External hardwiring* of instrumentation to ATE switching in the test fixture. The external approach will greatly increase test fixture complexity, however; the TPS developer has greater flexibility should higher performance instrumentation require uncompromising access at the tester interface.

#### 4.11.2.6.3 CIWG recommended switch requirements

**Suggestion 4.11.2.6.3:** The Critical Interface Working Group (CIWG) Report suggested certain switch requirements that could implement COTS solutions and preserve the needs of the Government legacy programs. The following goals were utilized in assessing switching candidates:

- a) Is widely accepted by industry with multi-vendor sources.
- b) Has established design definitions.
- c) Offers a full range of options to meet signal, power, and coax requirements.
- d) Supports high life-cycle performance and maintainability.
- e) Is available today in volume production and is in its early product life-cycle phase.
- f) Provides a scaleable switch with a modular framework design that permits ATS integrators to incrementally augment their systems through add-on/duplicative features. This will enable them to meet worst case requirements while maintaining downward compatibility with any smaller I/O increment.
- g) Establishes a common switch specification that offers multi-vendor sources, is flexible enough to support a wide variety of signal performance/switch configurations (1x2, 1x4, 1x8), and can evolve with new test needs.
- h) Minimizes pin out configuration to effect greater transportability and reconfigurability is not impaired.
- i) Reduces the proliferation of switch designs.
- j) Defines a minimum set of performance requirements that will meet the Government I/O basic switch needs. Common I/O basic switch envelope that supports legacy 1x2, 1x4, 1x8 wrap-around signal cascade TPS requirements.

**Recommendation 4.11.2.6.3:** The integrator determines switch requirements based on the number of instruments and the flexibility with which they must be applied. Switch designs require a compromise between direct wire performance and switch flexibility. The CIWG concluded that switching in the ATS with internal hard wiring should be required to achieve greater cost-effectiveness and minimize fixture complexity.

**4.11.2.6.4 CTI switch requirements**

**Rule 4.11.2.6.4:** The CTI shall employ a scaleable switch that applies high performance analog switch cards for any general purpose high-end ATE system. All switch functional requirements shall be implemented directly through the CTI to support legacy switch requirements, in accordance with CTI pin map I/O configuration and general pin map requirements, Annex A. The detailed descriptions of Table 3, Table 4, Table 5, and Table 6, as well as Figure 9, provide additional switch definition/requirements to be implemented under the CTI Specification.

**Table 3—Signal switch performance requirements**

Switch type	Characteristic	Requirement
Signal 1x2, 2A	Time, switch	<3ms
	Crosstalk	<-60 dB (adj channels)
	Current	2.0 A
	Isolation	$\geq 100 \text{ M}\Omega$
	Isolation	>45 dB @ 10 MHz
	Isolation	<1E9 $\Omega$ @ dc
	Power, switched	30 Wdc, 62.5 VA ac
	Resistance to ground	>100 M $\Omega$
	Resistance, path	<0.2 $\Omega$
	Voltage, breakdown	$\geq 1000 \text{ Vdc}$
	Voltage, switched	300 Vdc/300 Vac
Signal 1x2, 4A	Time, switch	<3 ms
	Crosstalk	<-60 dB (adj channels)
	Current, switched	4 A ac/dc
	Isolation	$\geq 100 \text{ M}\Omega$
	Isolation	>45 dB @ 10 MHz
	Isolation	<1E9 $\Omega$ @ dc
	Power, switched	90 Wdc, 1000 VA ac
	Resistance to ground	>100 M $\Omega$
	Resistance, path	< 0.2 $\Omega$
	Voltage, breakdown	$\geq 1000 \text{ Vdc}$
	Voltage, switched	300 Vdc/300 Vac

**Table 3—Signal switch performance requirements (continued)**

Switch type	Characteristic	Requirement
<b>Signal 1x4</b>	Time, switch	<3 ms
	Crosstalk	<-60 dB (adj channels)
	Current, switched	2A
	Isolation	>=100 MΩ
	Isolation	>45 dB @ 10 MHz
	Power, switched	30 Wdc, 62.5 VA ac
	Resistance, path	< 0.3 Ω
	Voltage, breakdown	>=1000 Vdc
	Voltage, switched	300 Vdc/300 Vac
<b>Signal 1x8</b>	Bandwidth (-3dB)	<100 MHz
	Time, switch	<3 ms
	Current, switched	2 A
	Isolation	<-45dB @ 10MHz
	Resistance, path	<1E9 MΩ
	Voltage, switched	300 Vdc/300 Vac
<b>Signal 8x24</b>	Bandwidth (-3dB)	20 MHz
	Time, switch	<3 ms
	Capacitance, CH to CH	<0.36 μF
	Crosstalk	<-60 dB @ 1 MHz
	Current, steady state	2.0 A
	Current, switched	2 A ac/dc
	Impedance, shunt cap	<0.5 μF
	Impedance	50 Ω
	Isolation	<-50 dB @ 10 MHz >=100 MΩ
	Resistance to ground	>100 MΩ
	Resistance, path	< 1.0 Ω
	Voltage, switched	300 Vdc/300 Vac
	Voltage, unswitched	350 Vac/dc

**Table 4—Power switch performance requirements**

Switch type	Characteristic	Requirement
<b>Power 1x1, 10 A</b>	Time, switch	<20 ms
	Current, steady state	10.0 A
	Current, switched	10 A ac/dc
	Isolation	>45 dB @ 5 kHz <1E9 $\Omega$ @ dc
	Power load rating	300 Wdc, 2000 VA/CH
	Resistance to ground	>100 M $\Omega$
	Resistance, path	< 0.1 $\Omega$
	Voltage, switched	220 V ac/dc
<b>Power 1x2, 10 A</b>	Time, switch	<20 ms
	Current, switched	10 A ac/dc
	Isolation	>45 dB @ 5 kHz <1E9 $\Omega$ @ dc
	Noise floor	<=-100 dBm @ quiescent
	Power, switched	300 Wdc, 2000 VA/CH
	Resistance to ground	>100 M $\Omega$
	Resistance, path	< 0.1 $\Omega$
	Voltage, switched	220 Vac/dc
<b>Power 1x2, 10 A, low-R</b>	Time, switch	<20 ms
	Current, contact rating	9 A
	Isolation	>=10 000 M $\Omega$
	Power, switched	300 Wdc, 2000 VA/CH
	Resistance to ground	>100 M $\Omega$
	Resistance, path	< 40 m $\Omega$ @ 9 A, < 500 m $\Omega$ @ 1 mAdc
	Voltage, breakdown	>=1000 Vdc
	Voltage, switched	250 Vac/125 Vdc
<b>Power 1x2, 20 A</b>	Time, switch	<20 ms
	Current, switched	20 A
	Power, switched	4800 Vac/560 Wdc
	Resistance to ground	>100 M $\Omega$
	Resistance, path	0.05 $\Omega$ to 0.1 $\Omega$
	Voltage, switched	240 Vac/220 Vdc

**Table 4—Power switch performance requirements (continued)**

Switch type	Characteristic	Requirement
<b>Power 1x2, 20 A, low-R</b>	Time, switch	<20 ms
	Current, contact Rating	18.75 A
	Current, switched	20 A
	Isolation	$\geq 10\,000\ \text{M}\Omega$
	Power, switched	4800 Vac/560 Wdc
	Resistance, path	<20 m $\Omega$ @ 18.75 A, <250 m $\Omega$ @ 1 mAdc
	Voltage, breakdown	$\geq 1000\ \text{Vdc}$
	Voltage, switched	240 Vac/220 Vdc
<b>Power 1x4, 20 A,</b>	Time, switch	<20 ms
	Current, switched	20 A
	Power, switched	560 Wdc/4800 Vac
	Resistance to ground	>100 M $\Omega$
	Resistance, path	< 0.1 $\Omega$
	Voltage, switched	240 Vac/220 Vdc
<b>Power 1x4, 20 A, low-R</b>	Time, switch	<20ms
	Current, contact rating	18.75 A
	Current, switched	20 A
	Isolation	$\geq 10\,000\ \text{M}\Omega$
	Power, switched	4800 Vac/560 Wdc
	Resistance to ground	>100 M $\Omega$
	Resistance, path	<20 m $\Omega$ @ 18.75 A, <250 m $\Omega$ @ 1 mAdc
	Voltage, breakdown	$\geq 1000\ \text{Vdc}$
	Voltage, switched	240 Vac/220 Vdc
<b>Power DPDT, 20A, low-R</b>	Time, switch	<20 ms
	Current, contact Rating	18.75 A
	Current, switched	20 A
	Isolation	$\geq 10\,000\ \text{M}\Omega$
	Power, switched	4800 Vac/560 Wdc
	Resistance to ground	>100 M $\Omega$
	Resistance, path	<20 m $\Omega$ @ 18.75 A, <250 m $\Omega$ @ 1 mAdc
	Voltage, breakdown	$\geq 1000\ \text{Vdc}$
	Voltage, switched	240 Vac/220 Vdc

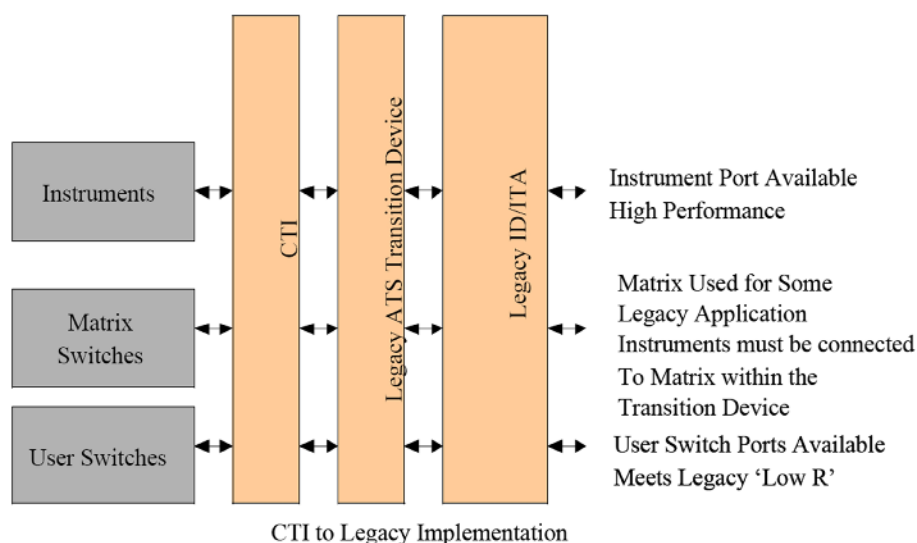

**Table 5—Coax switch performance requirements**

Switch type	Characteristic	Requirement
Coax 1x2	Frequency range	DC to 1.3 GHz
	Bandwidth loss	<0.2 dB @ 100 MHz <0.5 dB @ 500 MHz <2.0 dB @ 1 GHz
	Time, switch	≤15 msec
	Crosstalk	<-65 dB @ 100Mz <-60 dB @ 500Mz <-55 dB @ 1 GHz
	Isolation, input to output	<-70 dB @ 100 MHz; <-65 dB @ 500 MHz <-55 dB @ 1 GHz
	VSWR	<1.2:1 @ 100 MHz <1.5:1 @ 1 GHz
	Characteristic impedance	50 Ω
	Current, switched	0.5 A
	Power, max	+33 dBm (2 W into 50 Ω)
	Power, switched	10 Wdc
	Power, unswitched	10 Wdc
	Resistance, dc path	<1 Ω
	Coax 1x4	Frequency Range
Bandwidth Loss		<0.2 dB @ 100 MHz <0.5 dB @ 500 MHz <2.0 dB @ 1 GHz
Time, switch		≤15 msec
Crosstalk		<-65 dB @ 100 MHz <-60 dB @ 500 MHz <-55 dB @ 1 GHz
Isolation, Input to Output		<-70 dB @ 100 MHz <-65 dB @ 500 MHz <-55 dB @ 1 GHz
VSWR		<1.2:1 @ 100 MHz <1.5:1 @ 1 GHz
Characteristic impedance		50 Ω
Capacitance		<0.25 μF
Current, switched		1.0 A @ 28 Vdc
Current, Steady State		2 A
Power, max		+33 dBm (2 W into 50 Ω)
Power, switched		10 Wdc
Power, unswitched		10 Wdc
Resistance, dc path		<1 Ω
Resistance, to ground		>100 MΩ

**Table 6—CTI switch configuration requirements**

Switch nomenclature	Quantity	Power	Signal	Coax
Signal 1x2, 2 A	50		150	
Signal 1x2, 4 A	50		150	
Signal 1x4	16		80	
Signal 8x24	6		312	
Signal 8x8	16		288	
Power 1x1, 10 A	12	24		
Power 1x2, 10 A	12	36		
Power 1x2, 10 A low-R	12	36		
Power 1x2, 20 A	3	9		
Power 1x2, 20 A low-R	1	3		
Power DPDT, 20 A low-R	2	12		
Power 1x4, 20 A	1	5		
Power switch 1x4, 20A low-R	5	25		
Coax 1x2	9			27
Coax 1x4	48			240
<b>Totals</b>	<b>243</b>	<b>150</b>	<b>980</b>	<b>267</b>



**Figure 9—CTI switch architecture**

#### 4.12 CTI pin map input/output configuration

**Rule 4.12:** The CTI connector configuration and related CTI pin map I/O configuration and general pin map requirements, as defined in Annex A, shall be implemented in accordance with interconnect specifications detailed therein. These requirements within Annex A shall be divided into several I/O parametric categories/signal definitions, related legacy pin map I/O, and distributed in functional scaleable segments, to assure test signal mapping is maintained for all CTI applications. Pin map I/O descriptions for respective legacy systems shall be provided within Annex A to support legacy TPS and transition device requirements.

## Annex A

(normative)

### Common test interface signal definitions for pin map

#### A.1 Analog instruments (AI)

##### A.1.1 Analog-to-digital converter (ADC) analog-in (Table A.1)

Sixteen channels plus a trigger channel are mapped to 34 pins to support a 2-wire interface for each, i.e., Ch+, Ch-. Six shield pins are provided.

##### A.1.2 AI multi-parallel (Table A.2, Table A.3, and Table A.4)

Ninety-six channels are mapped to 192 pins to support a 2-wire interface for each. Thirty-two channels are mapped in the core. Each of the channels is capable of stimulus or measurement. As stimulus channels (function generator), capabilities include dc, sine, triangle, pulse, and arbitrary waveform generation. As measurement channels, capabilities include timer/counter, digitizer, digital multi-meter (DMM) and limit detect.

##### A.1.3 AWG (Table A.5)

The composite *arbitrary waveform generator* is comprised of 4 AWGs providing a total of 6 output channels: 1A, 1B, 2A, 2B, 3A, and 4A. Each of the 4 AWGs provide for external inputs. AWGs 1 and 2 allow for mark, trigger, and sync. AWG 3 allows for trigger and sync. AWG 4 allows trigger. These 15 interfaces are mapped to 30 pins to support a 2-wire interface for each. Two additional interfaces to the AWGs (DiffGate and DataGate) are mapped to 4 pins to support a 2-wire interface. These main functions are mapped to a total of 34 pins.

###### A.1.3.1 AWG emitter-coupled logic (ECL) outputs

Twenty-four differential, digital data bits provided by AWGs 1 and 2 (12 each) are mapped to 48 pins to support a 2-wire interface for each data bit. An AWG GND pin is mapped for each of these ports. These output ports are mapped to a total of 50 pins.

###### A.1.3.2 AWG-5

A fifth AWG adds the following 6 ports to the interface: Out, Out/7, Marker, ref, Start/Arm, StopTrigFsk. These ports are mapped to 6 coax contacts.

###### A.1.3.3 AWG function generator

The function generator has the following I/O: Out, Sync, Trig, Clock, and PM. These channels are mapped to 5 coax contacts.

#### **A.1.4 AWG520 (Table A.6)**

This unique capability AWG has 2 channels, 4 markers, 10 digital, an input trigger, 4 event triggers, clock-in, clock-out, and noise-gen. These 26 interfaces are mapped to 52 pins to support a 2-wire interface for each.

#### **A.1.5 Digital-to-analog converter (DAC) analog-out (Table A.7)**

##### **A.1.5.1 DAC 1**

DAC 1 has 16 channels, a trigger, and 8 keys. The first 12 channels provide for remote sense as these have 100 mA drive capability. The channels, trigger, and sense lines are collocated and are mapped as 2-wire interfaces to 58 pins. The keys are collocated and mapped as 2-wire interfaces to 16 pins. Two shield pins are provided.

##### **A.1.5.2 DAC 2**

DAC 2 has 16 channels and a trigger. The channels and trigger are collocated and are mapped as 2-wire interfaces to 34 pins. Six shield pins are provided.

#### **A.1.6 Digitizer (Table A.8)**

Four digitizer channels are mapped. Three supporting interfaces are mapped: dc Cal, ExtTrig, and Trig out. These 7 interfaces are mapped to 14 pins to support a 2-wire interface for each.

#### **A.1.7 DMM (Table A.9)**

The DMM has the customary Hi, Lo, Sense+, Sense-, and trigger paths. Two additional paths are mapped: Probe and DMM Done. These 7 interfaces are mapped to 14 pins to support a 2-wire interface for each. A Guard pin and Current pin round out the total to 16 pins.

#### **A.1.8 Frequency time interval counter and RF counter (Table A.10)**

The frequency time interval counter (FTIC) has 2 channels plus a single trigger/gate channel. These 3 interfaces are mapped to 6 pins to support a 2-wire interface for each. The RF counter has 2 interfaces: inhibit and threshold.

#### **A.1.9 Low-frequency calibrator (Table A.11)**

The low-frequency calibrator is mapped to 4 pins: Hi, Lo, Sense+, and Sense-. A guard pin and shield pin are mapped for a total of 6 pins.

#### **A.1.10 Open-collector driver (Table A.12)**

Ninety-six channels of open-collector drivers (OCDs) are mapped to 192 pins to support the 2-wire interface approach. Twelve I/O-control and 12 clock channels are mapped to 24 pins for a single wire

implementation. Two additional pins are mapped anticipating the need for returns for the I/O-control and clock channels, bringing the total for the OCD to 218 pins.

#### **A.1.11 Pulse generator 1 (Table A.13)**

Pulse generator 1 has 2 channels plus an external trigger-in and a trigger-out. These 4 interfaces are mapped to 8 pins to support a 2-wire interface for each.

#### **A.1.12 Pulse generator 2 (Table A.14)**

Pulse generator 2 has 2 channels plus an external trigger-in and a trigger-out. These 4 interfaces are mapped to 8 pins to support a 2-wire interface for each.

#### **A.1.13 Resistive load (Table A.15)**

The resistive load is mapped to 2 pins.

#### **A.1.14 Scope (Table A.16)**

Four oscilloscope channels plus an aux-out channel are mapped to 5 coax contacts.

#### **A.1.15 Syncro-resolver (Table A.17)**

Sixty-five pins are mapped for the syncro-resolver.

#### **A.1.16 Video (Table A.18)**

Two-hundred pins are mapped for video.

### **A.2 Bus**

#### **A.2.1 Programmable bus (Table A.19)**

Sixty-four programmable bus channels are mapped to 128 pins. The programmable channels support standard serial and parallel bus formats. Four additional pins are provided as GND pins to support 1553 GND pin requirements.

#### **A.2.2 IEEE 1149.1<sup>™</sup> boundary scan (Table A.20)**

Twenty-one pins are mapped for IEEE Std 1149.1-2001 [B13].

## **A.3 Digital**

### **A.3.1 Channels (Table A.21)**

Four hundred forty-eight channels are mapped to 896 pins to support a 2-wire interface for each, and 3 Kelvin grounds are mapped to 6 pins.

### **A.3.2 Clocks (Table A.22)**

Six control clocks, one reference, 4 sync, one Kelvin ground, 4 clocks, and 6 miscellaneous signals are mapped to 22 coax pins.

### **A.3.3 External control (Table A.23)**

Fifty-four channels are mapped to 108 pins to allow external control of the digital channels.

## **A.4 Instrument control**

### **A.4.1 Spectrum analyzer (Table A.24)**

Four channels, trigger, detected video, RF measure in, and 321.4 MHz IF are mapped to 4 coax contacts.

### **A.4.2 Modulation source (Table A.25)**

Thirteen modulation sources are mapped to 13 coax contacts. RF Source 1 has 4 channels: pulse amplitude modulation (PAM) trigger, amplitude modulation (AM), frequency modulation (FM), and an External Trigger IN. RF Source 2 also has RF AM, RF FM, RF PM, and an External Trigger IN. RF Source 3 has 4 channels: AM, FM, PAM, and an External Trigger IN. There is also a microwave transition analyzer (MTA) External Trigger IN, which rounds the total to 13.

### **A.4.3 Power meter (Table A.26)**

There are 4 power meter control interfaces. Three interfaces are mapped as: Ext Trig in, Video1, and Video2. These 3 interfaces are mapped to 3 coax contacts. The fourth interface, power meter recorder, is mapped to a coax contact.

## **A.5 Power loads**

### **A.5.1 Hi current ac/dc load (Table A.27)**

Two high current power loads are mapped to 8 power pins to support the high current path. Each of the high current loads has 2 Load (+) pins and 2 Load (–) pins.

### **A.5.2 AC/DC load (Table A.28)**

Six power loads are mapped to 12 power pins. Each of the current loads has a Load (+) pin and Load (–) pin.

### **A.5.3 Load modulation (Table A.29)**

A load modulation channel is mapped to 2 pins as Load Mod (+) and Load Mod (–). Load modulation allows a signal to vary the load about a programmed nominal value. (This applies to active loads only.)

## **A.6 Power supplies**

### **A.6.1 DC**

#### **A.6.1.1 High current DCPS (Table A.30)**

Ten high current DCPS are mapped to 40 power pins to support the current path. Each of the high current supplies has 2 DCPS (+) pins and 2 DCPS (–) pins.

#### **A.6.1.2 DCPS (Table A.31)**

Twelve DCPS are mapped to 24 power pins. Each of the supplies has a DCPS (+) pin and a DCPS (–) pin.

### **A.6.2 AC**

#### **A.6.2.1 AC power supply (ACPS) three phase (Table A.32)**

A three-phase source is mapped to 10 power pins. Phases A, B, and C, plus neutral and ground are mapped to 2 pins each to support the high current paths.

#### **A.6.2.2 ACPS programmable (Table A.33)**

Four programmable ac sources are mapped to 10 power pins. Each source has a complementary return. Two pins are mapped as ground. Four auxiliary power sources are mapped to 8 signal pins. Each source has a complementary return.

## **A.7 Sense and control, DCPS, and loads**

### **A.7.1 DCPS sense (Table A.34)**

Forty-four pins are mapped as sense lines for the 11 DCPS. Sense lines are paired as DCPS Sense (+) and DCPS Sense (–).



### **A.7.2 ACPS sense (Table A.35)**

Eight pins are mapped as sense lines for the 4 programmable ac sources.

### **A.7.3 Load sense (Table A.36)**

Two pins are mapped as sense lines for one of the high power loads: High Power Load Sense (+) and High Power Load Sense (-). Two additional pins are mapped as *chassis* ground.

### **A.7.4 28V Control (Table A.37)**

Two pins are mapped as control lines. Control 28 (+) and Control 28 (-) are inputs to the system to command a DCPS to the turn on.

## **A.8 Switch**

Three types of switches are mapped: coax, power, and signal.

NOTE—The selection of the matrix switches was mapped to meet legacy requirements. A system integrator can choose to populate a system with, for example, 2x8 switches that meet the recommend attributes vice 1x4 switches, wire them to the CTI and still be compliant, as long as the superset contains the required subset.

### **A.8.1 Coax switch (CSW)**

Two types of CSWs are mapped: 1x4 and 1x2.

#### **A.8.1.1 1x8**

1x8 CSWs can be created from 1x4 and 1x2 by appropriate wiring in an ITA/ID or transition adapter.

#### **A.8.1.2 1x4 (Table A.38)**

Forty-eight 1x4 CSWs are mapped to 240 coax contacts.

#### **A.8.1.3 1x2 (Table A.39)**

Nine 1x2 CSWs are mapped to 27 coax contacts.

### **A.8.2 Power switch**

Four types of power switches are mapped: 1x4, 1x2, DPDT, and 1x1.

#### **A.8.2.1 1x4 (Table A.40)**

Six 1x4 switches are mapped to 30 power pins. These are 20 A relays, however the CTI interface has a thermal restriction of 18 A in a cluster of 6 adjacent pins. Five of the six are low-R.

#### **A.8.2.2 1x2 (Table A.41)**

Twenty-one 1x2 switches are mapped to 55 power pins. One is 20 A and twenty are 10 A. The 20 A is low-R, and 12 of the 10 A are low-R.

#### **A.8.2.3 DPDT (Table A.42)**

Two double-pole-double-throw (DPDT), 20 A low-R relays are mapped to 12 power pins.

#### **CAUTION**

The CTI interface has a thermal restriction of 18 A in a cluster of 6 adjacent pins.

#### **A.8.2.4 1x1 (Table A.43)**

Twelve 1x1, 10 A switches are mapped to 24 power pins.

### **A.8.3 Signal switch**

Four types of signal switches are mapped: 1x8, 8x24, 1x4, and 1x2.

#### **A.8.3.1 1x8 (Table A.44)**

Two hundred and eighty-eight (288) pins are mapped to support 16 2-wire, 1x8 matrices.

#### **A.8.3.2 8x24 (Table A.45)**

Three hundred and twelve (312) pins are mapped to support 6 8x24 matrices. A return pin is mapped for each of the inputs. A return pin is mapped for every two outputs.

#### **A.8.3.3 1x4 (Table A.46)**

Sixteen 1x4 switches are mapped to 80 signal pins.

#### **A.8.3.4 1x2 (Table A.47)**

One hundred 1x2 switches are mapped to 300 signal pins. Fifty are 4 A and the remaining 50 are 2 A.

## **A.9 System**

### **A.9.1 ETE GND (Table A.48)**

Three pins have been mapped for engineering test and evaluation (ETE) grounds. The objective is to make ground pins available to support system trouble-shooting and ETE.

### **A.9.2 Frequency standard (Table A.49)**

Two frequency standards are mapped to 2 coax contacts: 10 MHz and 100 MHz.

### **A.9.3 System trigger (Table A.50)**

Four system interfaces are mapped: PH MOD IN, STA Sys Ext Input, STA Sys Trig A, and STA Sys Trig B+. These 4 interfaces are mapped with their respective returns to 8 pins to support a 2-wire interface for each.

Three system interfaces are mapped: STA Sys Trig A, STA Sys Trig B, and STA Sys Ext Input. STA Sys Trig A and STA Sys Trig B are mapped as twisted shielded pairs to 6 pins. STA Sys Ext Input is mapped with a respective shield to 2 pins.

### **A.9.4 Interrupts, interlocks, and shutdown (Table A.51)**

Ten UUT interrupts and 2 UUT interrupt return pins are mapped. A UUT interlock and its return are mapped. An ID interlock and its return are mapped in each of the 4 physical partitions of the interface. A UUT shutdown and its return are mapped. Two interlock pins were added for transition adapter handle closures, bringing the total to 18 pins. Nine system identification pins are also mapped.

### **A.9.5 Safety ground (Table A.52)**

Two power pins are mapped as safety ground. These paths can be tied together to serve as a single point ground.

Slot #	Slot #																										
	1	2	3	4	5	6	7	8	9	10	11	12	13	14	15	16	17	18	19	20	21	22	23	24	25	26	
Switch	1x8 2-wire																										
	8x24							16	36						144	144											
	1x4							10	10						52	52	156										
	1x2																30	30	126								
Digital	1x4, 20A																										
	DIPDT, 20A Low-R																										
	1x2																										
	1x1, 10A																										
Power	Coax																										
	1x4																										
	1x2																										
	Channels																										
Loads	Clocks																										
	ProbeCal																										
	External Control																										
	10 DC HI																										
PS & Load Sense	12 DC																										
	Fixed 3 Ph																										
	Prog 4 Ph																										
	2 HI DC																										
Analog	6 DC																										
	Mod In																										
	22 DC Sense																										
	4 AC Sense																										
Inst Ctrl	Load Sense																										
	28V Control																										
	ADC																										
	Multi Parallel Inst																										
Bus	ARB																										
	AWG520																										
	DAC																										
	Digitizer																										
System	DMM																										
	FTIC																										
	LFC																										
	OC																										
System	PGEN1																										
	PGEN2																										
	ResLoad																										
	Scope																										
System	Synchro Resolver																										
	Video																										
	Spec An Control																										
	Mod Svc																										
System	PM Control																										
	Programmable																										
	1149																										
	Cal Freq Std																										
System	Sys Trig																										
	Interupts/Interlocks																										
	Safety GND																										
	ETE Gnd																										
System	Slot Use																										
	Slot Capacity																										
	Slot Spare																										
	Slot Type																										

Figure A.1—Summary pin map

200 Pin Block			
A	B	C	D
1	1	1	1
2	2	2	2
3	3	3	3
4	4	4	4
5	5	5	5
6	6	6	6
7	7	7	7
8	8	8	8
9	9	9	9
10	10	10	10
11	11	11	11
12	12	12	12
13	13	13	13
14	14	14	14
15	15	15	15
16	16	16	16
17	17	17	17
18	18	18	18
19	19	19	19
20	20	20	20
21	21	21	21
22	22	22	22
23	23	23	23
24	24	24	24
25	25	25	25
26	26	26	26
27	27	27	27
28	28	28	28
29	29	29	29
30	30	30	30
31	31	31	31
32	32	32	32
33	33	33	33
34	34	34	34
35	35	35	35
36	36	36	36
37	37	37	37
38	38	38	38
39	39	39	39
40	40	40	40
41	41	41	41
42	42	42	42
43	43	43	43
44	44	44	44
45	45	45	45
46	46	46	46
47	47	47	47
48	48	48	48
49	49	49	49
50	50	50	50

152 Pin Block							
A	B	C	D	E	F	G	H
1	1	1	1	1	1	1	1
2	2	2	2	2	2	2	2
3	3	3	3	3	3	3	3
4	4	4	4	4	4	4	4
5	5	5	5	5	5	5	5
6	6	6	6	6	6	6	6
7	7	7	7	7	7	7	7
8	8	8	8	8	8	8	8
9	9	9	9	9	9	9	9
10	10	10	10	10	10	10	10
11	11	11	11	11	11	11	11
12	12	12	12	12	12	12	12
13	13	13	13	13	13	13	13
14	14	14	14	14	14	14	14
15	15	15	15	15	15	15	15
16	16	16	16	16	16	16	16
17	17	17	17	17	17	17	17
18	18	18	18	18	18	18	18
19	19	19	19	19	19	19	19

59 Pin Block		
A	B	C
1	1	1
2	2	2
3	3	3
4	4	4
5	5	5
6	6	6
7	7	7
8	8	8
9	9	9
10	10	10
11	11	11
12	12	12
13	13	13
14	14	14
15	15	15
16	16	16
17	17	17
18	18	18
19	19	19
20		20

Figure A.2—Connector configurations

**Table A.1—ADC analog in**

CTI name	Legacy system	Recommended attributes	Slot	Pin
ADC CH 1 (+)	SAMe, IAIS, C17	Max voltage: $\pm 40$ V Max impedance: 10 M $\Omega$ Max sample rate 100 kilosample/s Max BW: 80 kHz	18	A 41
ADC CH 1 (–)	“	“	18	B 41
ADC CH 2 (+)	“	“	18	B 42
ADC CH 2 (–)	“	“	18	A 42
ADC CH 3 (+)	“	“	18	A 43
ADC CH 3 (–)	“	“	18	B 43
ADC CH 4 (+)	“	“	18	B 44
ADC CH 4 (–)	“	“	18	A 44
ADC CH 5 (+)	“	“	18	A 45
ADC CH 5 (–)	“	“	18	B 45
ADC CH 6 (+)	“	“	18	B 46
ADC CH 6 (–)	“	“	18	A 46
ADC CH 7 (+)	“	“	18	A 47
ADC CH 7 (–)	“	“	18	B 47
ADC CH 8 (+)	“	“	18	B 48
ADC CH 8 (–)	“	“	18	A 48
ADC CH 9 (+)	“	“	18	A 49
ADC CH 9 (–)	“	“	18	B 49
ADC CH 10 (+)	SAMe, IAIS	“	18	B 50
ADC CH 10 (–)	“	“	18	A 50
ADC CH 11 (+)	“	“	18	C 41
ADC CH 11 (–)	“	“	18	D 41
ADC CH 12 (+)	“	“	18	D 42
ADC CH 12 (–)	“	“	18	C 42
ADC CH 13 (+)	“	“	18	C 43
ADC CH 13 (–)	“	“	18	D 43
ADC CH 14 (+)	“	“	18	D 44
ADC CH 14 (–)	“	“	18	C 44
ADC CH 15 (+)	“	“	18	C 45
ADC CH 15 (–)	“	“	18	D 45
ADC CH 16 (+)	“	“	18	D 46
ADC CH 16 (–)	“	“	18	C 46
ADC Trigger In (+)	SAMe, IAIS, C17	Voltage: $\pm 10$ V, 100 ns minimum trigger pulse width, 50 $\Omega$ input	18	C 47
ADC Trigger In (–)	SAMe, IAIS, C17	”	18	D 47
ADC Shield 1			18	D 48
ADC Shield 2			18	C 48
ADC Shield 3			18	C 49
ADC Shield 4			18	D 49
ADC Shield 5			18	D 50
ADC Shield 6			18	C 50

Table A.2—AI multi-parallel

CTI name	Legacy system	Recommended attributes	Slot	Pin
AI-Instr 1 CH 1 (+)	CASS, LM-STAR, C17	Max voltage: $\pm 200$ V Max current: $\pm 100$ mA Max freq: 25 MHz BW: 70 MHz (5 ns rise time)	7	A 17
AI-Instr 1 CH 1 (–)	“	“	7	B 17
AI-Instr 1 CH 2 (+)	“	“	7	B 18
AI-Instr 1 CH 2 (–)	“	“	7	A 18
AI-Instr 1 CH 3 (+)	“	“	7	A 19
AI-Instr 1 CH 3 (–)	“	“	7	B 19
AI-Instr 1 CH 4 (+)	“	“	7	B 20
AI-Instr 1 CH 4 (–)	“	“	7	A 20
AI-Instr 1 CH 5 (+)	“	“	7	A 21
AI-Instr 1 CH 5 (–)	“	“	7	B 21
AI-Instr 1 CH 6 (+)	“	“	7	B 22
AI-Instr 1 CH 6 (–)	“	“	7	A 22
AI-Instr 1 CH 7 (+)	CASS, LM-STAR, C17	“	7	A 23
AI-Instr 1 CH 7 (–)	“	“	7	B 23
AI-Instr 1 CH 8 (+)	“	“	7	B 24
AI-Instr 1 CH 8 (–)	“	“	7	A 24
AI-Instr 1 CH 9 (+)	“	“	7	A 25
AI-Instr 1 CH 9 (–)	“	“	7	B 25
AI-Instr 1 CH 10 (+)	“	“	7	B 26
AI-Instr 1 CH 10 (–)	“	“	7	A 26
AI-Instr 1 CH 11 (+)	“	“	7	A 27
AI-Instr 1 CH 11 (–)	“	“	7	B 27
AI-Instr 1 CH 12 (+)	“	“	7	B 28
AI-Instr 1 CH 12 (–)	“	“	7	A 28
AI-Instr 1 CH 13 (+)	“	“	7	A 29
AI-Instr 1 CH 13 (–)	“	“	7	B 29
AI-Instr 1 CH 14 (+)	“	“	7	B 30
AI-Instr 1 CH 14 (–)	“	“	7	A 30
AI-Instr 1 CH 15 (+)	“	“	7	A 31
AI-Instr 1 CH 15 (–)	“	“	7	B 31
AI-Instr 1 CH 16 (+)	“	“	7	B 32
AI-Instr 1 CH 16 (–)	“	“	7	A 32
AI-Instr 1 CH 17 (+)	“	“	7	C 17
AI-Instr 1 CH 17 (–)	“	“	7	D 17
AI-Instr 1 CH 18 (+)	“	“	7	D 18
AI-Instr 1 CH 18 (–)	“	“	7	C 18
AI-Instr 1 CH 19 (+)	“	“	7	C 19
AI-Instr 1 CH 19 (–)	“	“	7	D 19
AI-Instr 1 CH 20 (+)	“	“	7	D 20
AI-Instr 1 CH 20 (–)	“	“	7	C 20
AI-Instr 1 CH 21 (+)	“	“	7	C 21
AI-Instr 1 CH 21 (–)	“	“	7	D 21
AI-Instr 1 CH 22 (+)	“	“	7	D 22
AI-Instr 1 CH 22 (–)	“	“	7	C 22
AI-Instr 1 CH 23 (+)	“	“	7	C 23
AI-Instr 1 CH 23 (–)	“	“	7	D 23
AI-Instr 1 CH 24 (+)	“	“	7	D 24
AI-Instr 1 CH 24 (–)	“	“	7	C 24
AI-Instr 1 CH 25 (+)	“	“	7	C 25
AI-Instr 1 CH 25 (–)	“	“	7	D 25
AI-Instr 1 CH 26 (+)	“	“	7	D 26

**Table A.2—AI multi-parallel (continued)**

CTI name	Legacy system	Recommended attributes	Slot	Pin
AI-Instr 1 CH 26 (-)	“	“	7	C 26
AI-Instr 1 CH 27 (+)	“	“	7	C 27
AI-Instr 1 CH 27 (-)	“	“	7	D 27
AI-Instr 1 CH 28 (+)	“	“	7	D 28
AI-Instr 1 CH 28 (-)	“	“	7	C 28
AI-Instr 1 CH 29 (+)	“	“	7	C 29
AI-Instr 1 CH 29 (-)	“	“	7	D 29
AI-Instr 1 CH 30 (+)	“	“	7	D 30
AI-Instr 1 CH 30 (-)	“	“	7	C 30
AI-Instr 1 CH 31 (+)	“	“	7	C 31
AI-Instr 1 CH 31 (-)	“	“	7	D 31
AI-Instr 1 CH 32 (+)	“	“	7	D 32
AI-Instr 1 CH 32 (-)	“	“	7	C 32

**Table A.3—AI multi-parallel No. 2**

CTI name	Legacy system	Recommended attributes	Slot	Pin
AI-Instr 2 CH 1 (+)	CASS, LM-STAR, C17	Max voltage: ± 200 V Max current: ±100 mA Max freq: 25 MHz BW: 70 MHz (5 ns rise time)	20	A 17
AI-Instr 2 CH 1 (-)	“	“	20	B 17
AI-Instr 2 CH 2 (+)	“	“	20	B 18
AI-Instr 2 CH 2 (-)	“	“	20	A 18
AI-Instr 2 CH 3 (+)	“	“	20	A 19
AI-Instr 2 CH 3 (-)	“	“	20	B 19
AI-Instr 2 CH 4 (+)	“	“	20	B 20
AI-Instr 2 CH 4 (-)	“	“	20	A 20
AI-Instr 2 CH 5 (+)	“	“	20	A 21
AI-Instr 2 CH 5 (-)	“	“	20	B 21
AI-Instr 2 CH 6 (+)	“	“	20	B 22
AI-Instr 2 CH 6 (-)	“	“	20	A 22
AI-Instr 2 CH 7 (+)	“	“	20	A 23
AI-Instr 2 CH 7 (-)	“	“	20	B 23
AI-Instr 2 CH 8 (+)	“	“	20	B 24
AI-Instr 2 CH 8 (-)	“	“	20	A 24
AI-Instr 2 CH 9 (+)	“	“	20	A 25
AI-Instr 2 CH 9 (-)	“	“	20	B 25
AI-Instr 2 CH 10 (+)	“	“	20	B 26
AI-Instr 2 CH 10 (-)	“	“	20	A 26
AI-Instr 2 CH 11 (+)	“	“	20	A 27
AI-Instr 2 CH 11 (-)	“	“	20	B 27
AI-Instr 2 CH 12 (+)	“	“	20	B 28
AI-Instr 2 CH 12 (-)	“	“	20	A 28
AI-Instr 2 CH 13 (+)	“	“	20	A 29
AI-Instr 2 CH 13 (-)	“	“	20	B 29
AI-Instr 2 CH 14 (+)	“	“	20	B 30
AI-Instr 2 CH 14 (-)	“	“	20	A 30
AI-Instr 2 CH 15 (+)	“	“	20	A 31
AI-Instr 2 CH 15 (-)	“	“	20	B 31



Table A.3—AI multi-parallel No. 2 (continued)

CTI name	Legacy system	Recommended attributes	Slot	Pin
AI-Instr 2 CH 16 (+)	“	“	20	B 32
AI-Instr 2 CH 16 (–)	“	“	20	A 32
AI-Instr 2 CH 17 (+)	“	“	20	A 33
AI-Instr 2 CH 17 (–)	“	“	20	B 33
AI-Instr 2 CH 18 (+)	“	“	20	B 34
AI-Instr 2 CH 18 (–)	“	“	20	A 34
AI-Instr 2 CH 19 (+)	“	“	20	A 35
AI-Instr 2 CH 19 (–)	“	“	20	B 35
AI-Instr 2 CH 20 (+)	“	“	20	B 36
AI-Instr 2 CH 20 (–)	“	“	20	A 36
AI-Instr 2 CH 21 (+)	“	“	20	A 37
AI-Instr 2 CH 21 (–)	“	“	20	B 37
AI-Instr 2 CH 22 (+)	“	“	20	B 38
AI-Instr 2 CH 22 (–)	“	“	20	A 38
AI-Instr 2 CH 23 (+)	“	“	20	A 39
AI-Instr 2 CH 23 (–)	“	“	20	B 39
AI-Instr 2 CH 24 (+)	“	“	20	B 40
AI-Instr 2 CH 24 (–)	“	“	20	A 40
AI-Instr 2 CH 25 (+)	“	“	20	A 41
AI-Instr 2 CH 25 (–)	“	“	20	B 41
AI-Instr 2 CH 26 (+)	“	“	20	B 42
AI-Instr 2 CH 26 (–)	“	“	20	A 42
AI-Instr 2 CH 27 (+)	“	“	20	A 43
AI-Instr 2 CH 27 (–)	“	“	20	B 43
AI-Instr 2 CH 28 (+)	“	“	20	B 44
AI-Instr 2 CH 28 (–)	“	“	20	A 44
AI-Instr 2 CH 29 (+)	“	“	20	A 45
AI-Instr 2 CH 29 (–)	“	“	20	B 45
AI-Instr 2 CH 30 (+)	“	“	20	B 46
AI-Instr 2 CH 30 (–)	“	“	20	A 46
AI-Instr 2 CH 31 (+)	“	“	20	A 47
AI-Instr 2 CH 31 (–)	“	“	20	B 47
AI-Instr 2 CH 32 (+)	“	“	20	B 48
AI-Instr 2 CH 32 (–)	“	“	20	A 48

**Table A.4—AI multi-parallel No. 3**

CTI name	Legacy systems	Recommended attributes	Slot	Pin
AI-Instr 3 CH 1 (+)	CASS, LM-STAR	Max voltage: $\pm 200$ V Max current: $\pm 100$ mA Max freq: 25 MHz BW: 70 MHz (5 ns rise time)	20	C 17
AI-Instr 3 CH 1 (-)	“	“	20	D 17
AI-Instr 3 CH 2 (+)	“	“	20	D 18
AI-Instr 3 CH 2 (-)	“	“	20	C 18
AI-Instr 3 CH 3 (+)	“	“	20	C 19
AI-Instr 3 CH 3 (-)	“	“	20	D 19
AI-Instr 3 CH 4 (+)	“	“	20	D 20
AI-Instr 3 CH 4 (-)	“	“	20	C 20
AI-Instr 3 CH 5 (+)	“	“	20	C 21
AI-Instr 3 CH 5 (-)	“	“	20	D 21
AI-Instr 3 CH 6 (+)	“	“	20	D 22
AI-Instr 3 CH 6 (-)	“	“	20	C 22
AI-Instr 3 CH 7 (+)	“	“	20	C 23
AI-Instr 3 CH 7 (-)	“	“	20	D 23
AI-Instr 3 CH 8 (+)	“	“	20	D 24
AI-Instr 3 CH 8 (-)	“	“	20	C 24
AI-Instr 3 CH 9 (+)	“	“	20	C 25
AI-Instr 3 CH 9 (-)	“	“	20	D 25
AI-Instr 3 CH 10 (+)	“	“	20	D 26
AI-Instr 3 CH 10 (-)	“	“	20	C 26
AI-Instr 3 CH 11 (+)	“	“	20	C 27
AI-Instr 3 CH 11 (-)	“	“	20	D 27
AI-Instr 3 CH 12 (+)	“	“	20	D 28
AI-Instr 3 CH 12 (-)	“	“	20	C 28
AI-Instr 3 CH 13 (+)	“	“	20	C 29
AI-Instr 3 CH 13 (-)	“	“	20	D 29
AI-Instr 3 CH 14 (+)	“	“	20	D 30
AI-Instr 3 CH 14 (-)	“	“	20	C 30
AI-Instr 3 CH 15 (+)	“	“	20	C 31
AI-Instr 3 CH 15 (-)	“	“	20	D 31
AI-Instr 3 CH 16 (+)	“	“	20	D 32
AI-Instr 3 CH 16 (-)	“	“	20	C 32
AI-Instr 3 CH 17 (+)	“	“	20	C 33
AI-Instr 3 CH 17 (-)	“	“	20	D 33
AI-Instr 3 CH 18 (+)	“	“	20	D 34
AI-Instr 3 CH 18 (-)	“	“	20	C 34
AI-Instr 3 CH 19 (+)	“	“	20	C 35
AI-Instr 3 CH 19 (-)	“	“	20	D 35
AI-Instr 3 CH 20 (+)	“	“	20	D 36
AI-Instr 3 CH 20 (-)	“	“	20	C 36
AI-Instr 3 CH 21 (+)	“	“	20	C 37
AI-Instr 3 CH 21 (-)	“	“	20	D 37
AI-Instr 3 CH 22 (+)	“	“	20	D 38
AI-Instr 3 CH 22 (-)	“	“	20	C 38
AI-Instr 3 CH 23 (+)	“	“	20	C 39
AI-Instr 3 CH 23 (-)	“	“	20	D 39
AI-Instr 3 CH 24 (+)	“	“	20	D 40
AI-Instr 3 CH 24 (-)	“	“	20	C 40
AI-Instr 3 CH 25 (+)	“	“	20	C 41
AI-Instr 3 CH 25 (-)	“	“	20	D 41
AI-Instr 3 CH 26 (+)	“	“	20	D 42
AI-Instr 3 CH 26 (-)	“	“	20	C 42

Table A.4—AI multi-parallel No. 3 (continued)

CTI name	Legacy systems	Recommended attributes	Slot	Pin
AI-Instr 3 CH 27 (+)	“	“	20	C 43
AI-Instr 3 CH 27 (-)	“	“	20	D 43
AI-Instr 3 CH 28 (+)	“	“	20	D 44
AI-Instr 3 CH 28 (-)	“	“	20	C 44
AI-Instr 3 CH 29 (+)	“	“	20	C 45
AI-Instr 3 CH 29 (-)	“	“	20	D 45
AI-Instr 3 CH 30 (+)	“	“	20	D 46
AI-Instr 3 CH 30 (-)	“	“	20	C 46
AI-Instr 3 CH 31 (+)	“	“	20	C 47
AI-Instr 3 CH 31 (-)	“	“	20	D 47
AI-Instr 3 CH 32 (+)	“	“	20	D 48
AI-Instr 3 CH 32 (-)	“	“	20	C 48

Table A.5—AWG

CTI name	Legacy system	Recommended attributes	Slot	Pin
AWG1 CHA	IFTE, CASS, LM-STAR, ESTS, TETS, IAIS, C17, RAF	Max voltage: $\pm 6$ V Max freq. 25 MHz Impedance: 50 $\Omega$ Current: 1 A Min pulse width: 15 ns	8	B 12
AWG1 Shield	“		8	A 12
AWG1 EXT TRIG	“	Max voltage: $\pm 8$ V Max freq. 645 kHz Impedance: 50 $\Omega$ Current: 1 A Min pulse width: 10 ns	8	A 13
AWG1 Shield	“		8	B 13
AWG1 CHB	IFTE, CASS, LM-STAR, ESTS, IAIS	Max voltage: $\pm 6$ V Max freq. 6 MHz Impedance: 50 $\Omega$ Current: 1 A Min pulse width: 15 ns	8	B 14
AWG1 Shield	“		8	A 14
AWG1 EXT SYNC	IFTE, CASS, LM- STAR, ESTS, TETS, IAIS, C17, RAF	Max voltage: 0 to +5.5 V Max freq. 25MHz Impedance: 50 $\Omega$ Current: 1 A Min pulse width: 10 ns	8	A 15
AWG1 Shield	“		8	B 15
AWG1 MRK SYNC (AM Input)	LM-STAR, ESTS, IAIS, C17	Max voltage: 0 to +5.5 V Max freq: 25 MHz Impedance: 50 $\Omega$ Current: 1 A	8	B 16
AWG1 Shield	“		8	A 16

**Table A.5—AWG (continued)**

CTI name	Legacy system	Recommended attributes	Slot	Pin
AWG2 MRK SYNC	LM-STAR, IAIS, C17	Max voltage: 0 to +5.5 V Max freq: 25 MHz Impedance: 50 Ω Current: 1 A	8	A 19
AWG2 Shield	“		8	B 19
AWG2 CHA	IFTE, LM-STAR, TETS, IAIS, C17, RAF	Max voltage: ± 6 V Max freq. 25 MHz Impedance: 50 Ω Current: 1 A	8	B 20
AWG2 Shield	“		8	C 12
AWG2 CHB	IFTE, LM-STAR, IAIS	Max voltage: ± 6 V Max freq. 6 MHz Impedance: 50 Ω Current: 1 A	8	C 13
AWG2 Shield	“		8	D 13
AWG2 EXT SYNC	IFTE, LM-STAR, ESTS, IAIS, C17, RAF	Max voltage: 0 to + 5.5 V Max freq. 25 MHz Impedance: 50 Ω Current: 1 A Min Pulse width: 10 ns	8	D 14
AWG2 Shield	“		8	C 14
AWG3 CHA	RAF	Max voltage: ± 6 V Max freq. 25 MHz Impedance: 50 Ω Current: 1 A	8	C 15
AWG3 Shield	“		8	D 15
AWG3 EXT TRIG	IFTE, TETS, RAF	Max voltage: ± 8 V Max freq. 160 MHz Impedance: 50 Ω Current: 1 A Min pulse width: 10 ns	8	D 16
AWG3 Shield	“		8	C 16
AWG3 EXT SYNC	IFTE, TETS, RAF	Max voltage: 0 to 5.5 V Max freq. 25 MHz Impedance: 50 Ω Current: 1 A	8	C 17
AWG3 Shield	“		8	D 17
AWG4 CHA	IFTE, RAF	Max voltage: ± 6 V Max freq. 25 MHz Impedance: 50 Ω Current: 1 A	8	D 18
AWG4 Shield	“		8	C 18
AWG4 EXT Trigger	“	Max voltage: ± 8 V Max freq. 160 MHz Impedance: 50 Ω Current: 1 A Min pulse width: 10 ns	8	C 19
AWG4 Shield	“		8	D 19
FGEN FG Clock	TETS	Voltage range: 0.01 to 16 Vpp Max freq: 100 MHz Impedance: 50 Ω	21,22	D 18
FGEN FG PM	“	“	21,22	D 19
AWG1 Dig Out 1 (+)	CASS, LM-STAR	Max voltage: Diff ECL Max freq: 100 MPPS	27	A 39

Table A.5—AWG (continued)

CTI name	Legacy system	Recommended attributes	Slot	Pin
AWG1 Dig Out 1 (–)	“	“	27	B 39
AWG1 Dig Out 2 (+)	“	“	27	B 40
AWG1 Dig Out 2 (–)	“	“	27	A 40
AWG1 Dig Out 3 (+)	“	“	27	A 41
AWG1 Dig Out 3 (–)	“	“	27	B 41
AWG1 Dig Out 4 (+)	“	“	27	B 42
AWG1 Dig Out 4 (–)	“	“	27	A 42
AWG1 Dig Out 5 (+)	“	“	27	A 43
AWG1 Dig Out 5 (–)	“	“	27	B 43
AWG1 Dig Out 6 (+)	“	“	27	B 44
AWG1 Dig Out 6 (–)	“	“	27	A 44
AWG1 Dig Out 7 (+)	“	“	27	A 45
AWG1 Dig Out 7 (–)	“	“	27	B 45
AWG1 Dig Out 8 (+)	“	“	27	B 46
AWG1 Dig Out 8 (–)	“	“	27	A 46
AWG1 Dig Out 9 (+)	“	“	27	A 47
AWG1 Dig Out 9 (–)	“	“	27	B 47
AWG1 Dig Out 10 (+)	“	“	27	B 48
AWG1 Dig Out 10 (–)	“	“	27	A 48
AWG1 Dig Out 11 (+)	“	“	27	A 49
AWG1 Dig Out 11 (–)	“	“	27	B 49
AWG1 Dig Out 12 (+)	“	“	27	B 50
AWG1 Dig Out 12 (–)	“	“	27	A 50
AWG2 Dig Out 1 (+)	“	“	27	C 39
AWG2 Dig Out 1 (–)	“	“	27	D 39
AWG2 Dig Out 2 (+)	“	“	27	D 40
AWG2 Dig Out 2 (–)	“	“	27	C 40
AWG2 Dig Out 3 (+)	“	“	27	C 41
AWG2 Dig Out 3 (–)	“	“	27	D 41
AWG2 Dig Out 4 (+)	“	“	27	D 42
AWG2 Dig Out 4 (–)	“	“	27	C 42
AWG2 Dig Out 5 (+)	“	“	27	C 43
AWG2 Dig Out 5 (–)	“	“	27	D 43
AWG2 Dig Out 6 (+)	“	“	27	D 44
AWG2 Dig Out 6 (–)	“	“	27	C 44
AWG2 Dig Out 7 (+)	“	“	27	C 45
AWG2 Dig Out 7 (–)	“	“	27	D 45
AWG2 Dig Out 8 (+)	“	“	27	D 46
AWG2 Dig Out 8 (–)	“	“	27	C 46
AWG2 Dig Out 9 (+)	“	“	27	C 47
AWG2 Dig Out 9 (–)	“	“	27	D 47
AWG2 Dig Out 10 (+)	“	“	27	D 48
AWG2 Dig Out 10 (–)	“	“	27	C 48
AWG2 Dig Out 11 (+)	“	“	27	C 49
AWG2 Dig Out 11 (–)	“	“	27	D 49
AWG2 Dig Out 12 (+)	“	“	27	D 50
AWG2 Dig Out 12 (–)	“	“	27	C 50
AWG1 Dig Out GND	“	“	27	C 38
AWG2 Dig Out GND	“	“	27	D 38
AWG1 DIFFGATEH	LM-STAR	Differential TTL 30 ns pulse width (min)	8	A 17
AWG1 DIFFGATEL	“	See above	8	B 17
AWG1 DATAGATEH	“	See above	8	B 18
AWG1 DATAGATEL	“	See above	8	A 18

**Table A.5—AWG (continued)**

CTI name	Legacy system	Recommended attributes	Slot	Pin
FGEN FG_Trig	TETS	TTL	21,22	E 17
FGEN FG_Sync	IFTE	Voltage range: 0.01 to 16 Vpp Max freq: 100 MHz Impedance: 50 Ω	21,22	E 18
FGEN FG_Out	TETS	Voltage range: 0.01 to 16 Vpp Max freq: 50 MHz Impedance: 50 Ω	21,22	E 19
AWG-OUT/7 (Output of AWG divided by 7)	TETS	Voltage: 5 V Max freq: 100 MHz Impedance: 50 Ω	21,22	A 18
AWG-MARKER	TETS	Voltage 0 – 2.5V Impedance: 50 Ω	21,22	A 19
AWG-REF	TETS	Voltage: 5 V Max freq: 100 MHz Impedance: 50 Ω	21,22	B 18
AWG-STARTARM	TETS	Max freq: 20 MHz TTL level	21,22	B 19
AWG-STOPTRIGFSK	TETS	Voltage: 5 V Max freq: 100 MHz Impedance: 50 Ω	21,22	C 18
AWG-OUT	TETS	Voltage: 1 Vpp Max freq: 10MHz Impedance: 50 Ω to 75 Ω	21,22	C 19

Table A.6—AWG520

CTI name	Legacy system	Recommended attributes	Slot	Pin
AWG520 OutPut 1	LM-STAR	0.020 Vpp to 2 Vpp into 50 $\Omega$ 1.000 Hz to 100.0 MHz Sine, triangle, square, ramp, pulse, or dc	28	A 17
AWG520 Shield	“	“	28	B 17
AWG520 Output 2	“	“	28	B 18
AWG520 Shield	“	“	28	A 18
AWG520 MarkerOut 1	“	Max voltage: 2 V BW: 700 MHz (rise time 0.5 ns @ $\pm 0.5$ V)	28	A 19
AWG520 Shield	“	“	28	B 19
AWG520 MarkerOut 2	“	“	28	B 20
AWG520 Shield	“	“	28	A 20
AWG520 MarkerOut 3	“	“	28	A 21
AWG520 Shield	“	“	28	B 21
AWG520 MarkerOut 4	“	“	28	B 22
AWG520 Shield	“	“	28	A 22
AWG520 DigOut 0	“	Max voltage: $\pm 8$ V BW: 700 MHz	28	A 23
AWG520 Shield	“	“	28	B 23
AWG520 DigOut 1	“	“	28	B 24
AWG520 Shield	“	“	28	A 24
AWG520 DigOut 2	“	“	28	A 25
AWG520 Shield	“	“	28	B 25
AWG520 DigOut 3	“	“	28	B 26
AWG520 Shield	“	“	28	A 26
AWG520 DigOut 4	“	“	28	A 27
AWG520 Shield	“	“	28	B 27
AWG520 DigOut 5	“	“	28	B 28
AWG520 Shield	“	“	28	A 28
AWG520 DigOut 6	“	“	28	A 29
AWG520 Shield	“	“	28	B 29
AWG520 DigOut 7	“	“	28	C 17
AWG520 Shield	“	“	28	D 17
AWG520 DigOut 8	“	“	28	D 18
AWG520 Shield	“	“	28	C 18
AWG520 DigOut 9	“	“	28	C 19
AWG520 Shield	“	“	28	D 19
AWG520 Trig_In	“	Input impedance: 1 k $\Omega$ or 50 $\Omega$ Max voltage: $\pm 10$ V Min pulse width: 10 ns	28	D 20
AWG520 Shield	“	“	28	C 20
AWG520 Event Trig1	“	Max voltage: 5 V	28	C 21
AWG520 Shield	“	“	28	D 21
AWG520 Event Trig2	“	“	28	D 22
AWG520 Shield	“	“	28	C 22
AWG520 Event Trig3	“	“	28	C 23
AWG520 Shield	“	“	28	D 23
AWG520 Event Trig4	“	“	28	D 24



**Table A.6—AWG520 (continued)**

CTI name	Legacy system	Recommended attributes	Slot	Pin
AWG520 Shield	“	“	28	C 24
AWG520 Clock in	“	Impedance: 50 $\Omega$ Max voltage: $\pm 10$ V Freq: 900 MHz	28	C 25
AWG520 Shield	“	“	28	D 25
AWG520 Noise gen	“	Range: $-145$ dBm/Hz to $-105$ dBm/Hz @ 100 K reference Freq: 300 MHz	28	D 26
AWG520 Shield	“	“	28	C 26
AWG520 Clock out	“	Level: ECL 100 K compatible	28	C 27
AWG520 Shield	“	“	28	D 27
Logic Analyser (LA) trig in	LM-STAR	Trigger in arms logic analyzer. 15 ns typical delay TTL	28	D 28
LA trig shd	“	“	28	C 28
LA trig out	“	Trigger to trigger out. 150 ns typical delay TTL	28	C 29
LA trig shd	“	“	28	D 29

**Table A.7—DAC analog out**

CTI name	Legacy systems	Recommended attributes	Slot	Pin
DAC1 CH 1 (+)	IFTE, SAME, ESTS, IAIS, RAF	Max voltage: $\pm 20$ V Max current: $\pm 50$ mA Max freq: 100 MHz	8	A 21
DAC1 CH 1 (–)	“	“	8	B 21
DAC1 CH 2 (+)	“	“	8	B 22
DAC1 CH 2 (–)	“	“	8	A 22
DAC1 CH 3 (+)	“	“	8	A 23
DAC1 CH 3 (–)	“	“	8	B 23
DAC1 CH 4 (+)	“	“	8	B 24
DAC1 CH 4 (–)	“	“	8	A 24
DAC1 CH 5 (+)	IFTE, SAME, ESTS, IAIS	“	8	A 25
DAC1 CH 5 (–)	“	“	8	B 25
DAC1 CH 6 (+)	“	“	8	B 26
DAC1 CH 6 (–)	“	“	8	A 26
DAC1 CH 7 (+)	“	“	8	A 27
DAC1 CH 7 (–)	“	“	8	B 27
DAC1 CH 8 (+)	“	“	8	B 28
DAC1 CH 8 (–)	“	“	8	A 28
DAC1 CH 9 (+)	SAME, ESTS, IAIS	“	8	A 29
DAC1 CH 9 (–)	“	“	8	B 29
DAC1 CH 10 (+)	“	“	8	B 30
DAC1 CH 10 (–)	“	“	8	A 30
DAC1 CH 11 (+)	“	“	8	A 31
DAC1 CH 11 (–)	“	“	8	B 31
DAC1 CH 12 (+)	“	“	8	B 32

Table A.7—DAC analog out (continued)

CTI name	Legacy systems	Recommended attributes	Slot	Pin
DAC1 CH 12 (–)	“	“	8	A 32
DAC1 CH 13 (+)	SAMe, IAIS	“	8	A 33
DAC1 CH 13 (–)	“	“	8	B 33
DAC1 CH 14 (+)	“	“	8	B 34
DAC1 CH 14 (–)	“	“	8	A 34
DAC1 CH 15 (+)	“	“	8	C 21
DAC1 CH 15 (–)	“	“	8	D 21
DAC1 CH 16 (+)	“	“	8	D 22
DAC1 CH 16 (–)	“	“	8	C 22
DAC1 Trig_In (+)	“	Min trigger pulse: 100 ns Trigger input: 50 $\Omega$ Voltage: TTL	8	C 23
DAC1 Trig_In (–)	“	“	8	D 23
DAC1 Sense CH 1 (+)	ESTS, RAF	Max voltage: $\pm 20V$ Max current: $\pm 50$ mA Max freq: 100 MHz	8	D 24
DAC1 Sense CH 1 (–)	“	“	8	C 24
DAC1 Sense CH 2 (+)	“	“	8	C 25
DAC1 Sense CH 2 (–)	“	“	8	D 25
DAC1 Sense CH 3 (+)	“	“	8	D 26
DAC1 Sense CH 3 (–)	“	“	8	C 26
DAC1 Sense CH 4 (+)	“	“	8	C 27
DAC1 Sense CH 4 (–)	“	“	8	D 27
DAC1 Sense CH 5 (+)	ESTS	“	8	D 28
DAC1 Sense CH 5 (–)	“	“	8	C 28
DAC1 Sense CH 6 (+)	“	“	8	C 29
DAC1 Sense CH 6 (–)	“	“	8	D 29
DAC1 Sense CH 7 (+)	“	“	8	D 30
DAC1 Sense CH 7 (–)	“	“	8	C 30
DAC1 Sense CH 8 (+)	“	“	8	C 31
DAC1 Sense CH 8 (–)	“	“	8	D 31
DAC1 Sense CH 9 (+)	“	“	8	D 32
DAC1 Sense CH 9 (–)	“	“	8	C 32
DAC1 Sense CH 10 (+)	“	“	8	C 33
DAC1 Sense CH 10 (–)	“	“	8	D 33
DAC1 Sense CH 11 (+)	“	“	8	D 34
DAC1 Sense CH 11 (–)	“	“	8	C 34
DAC1 Sense CH 12 (+)	“	“	8	C 35
DAC1 Sense CH 12 (–)	“	“	8	D 35
DAC1 Shield 1	“	N/A	8	A 35
DAC1 Shield 2	“	N/A	8	B 35
DAC1 Key 1 (+)	IFTE, SAMe, IAIS	Voltage level: TTL Min pulse width: 8 $\mu$ s	28	B 30
DAC1 Key 1 (–)	“	“	28	A 30
DAC1 Key 2 (+)	“	“	28	A 31
DAC1 Key 2 (–)	“	“	28	B 31
DAC1 Key 3 (+)	“	“	28	B 32
DAC1 Key 3 (–)	“	“	28	A 32
DAC1 Key 4 (+)	“	“	28	A 33
DAC1 Key 4 (–)	“	“	28	B 33
DAC1 Key 5 (+)	“	“	28	D 30

**Table A.7—DAC analog out (continued)**

CTI name	Legacy systems	Recommended attributes	Slot	Pin
DAC1 Key 5 (-)	“	“	28	C 30
DAC1 Key 6 (+)	“	“	28	C 31
DAC1 Key 6 (-)	“	“	28	D 31
DAC1 Key 7 (+)	“	“	28	D 32
DAC1 Key 7 (-)	“	“	28	C 32
DAC1 Key 8 (+)	“	“	28	C 33
DAC1 Key 8 (-)	“	“	28	D 33
DAC2 CH 1 (+)	SAME, IAIS	Max voltage: $\pm 20V$ Max current: $\pm 50\text{ mA}$ Max freq: 100 MHz	18	C 1
DAC2 CH 1 (-)	“	“	18	D 1
DAC2 CH 2 (+)	“	“	18	D 2
DAC2 CH 2 (-)	“	“	18	C 2
DAC2 CH 3 (+)	“	“	18	C 3
DAC2 CH 3 (-)	“	“	18	D 3
DAC2 CH 4 (+)	“	“	18	D 4
DAC2 CH 4 (-)	“	“	18	C 4
DAC2 CH 5 (+)	“	“	18	C 5
DAC2 CH 5 (-)	“	“	18	D 5
DAC2 CH 6 (+)	“	“	18	D 6
DAC2 CH 6 (-)	“	“	18	C 6
DAC2 CH 7 (+)	“	“	18	C 7
DAC2 CH 7 (-)	“	“	18	D 7
DAC2 CH 8 (+)	“	“	18	D 8
DAC2 CH 8 (-)	“	“	18	C 8
DAC2 CH 9 (+)	“	“	18	C 9
DAC2 CH 9 (-)	“	“	18	D 9
DAC2 CH 10 (+)	“	“	18	D 10
DAC2 CH 10 (-)	“	“	18	C 10
DAC2 CH 11 (+)	“	“	18	C 11
DAC2 CH 11 (-)	“	“	18	D 11
DAC2 CH 12 (+)	“	“	18	D 12
DAC2 CH 12 (-)	“	“	18	C 12
DAC2 CH 13 (+)	“	“	18	C 13
DAC2 CH 13 (-)	“	“	18	D 13
DAC2 CH 14 (+)	“	“	18	D 14
DAC2 CH 14 (-)	“	“	18	C 14
DAC2 CH 15 (+)	“	“	18	C 15
DAC2 CH 15 (-)	“	“	18	D 15
DAC2 CH 16 (+)	“	“	18	D 16
DAC2 CH 16 (-)	“	“	18	C 16
DAC2 Trig_In (+)	“	Min trigger pulse: 100 ns Trigger input: 50 $\Omega$ Voltage: TTL	18	C 17
DAC2 Trig_In (-)	“	“	18	D 17
DAC2 Shield 1	“	“	18	D 18
DAC2 Shield 2	“	“	18	C 18
DAC2 Shield 3	“	“	18	C 19
DAC2 Shield 4	“	“	18	D 19
DAC2 Shield 5	“	“	18	D 20
DAC2 Shield 6	“	“	18	C 20

Table A.8—Digitizer

CTI name	Legacy system	Recommended attributes	Slot	Pin
Digitizer Probe A	IFTE, CASS, TETS	Max voltage: 250 V max Max current 140 mA Max freq: 500 MHz @ 50 $\Omega$	8	D 36
Digitizer Shield	“	“	8	C 36
Digitizer Probe B	IFTE, CASS	“	8	C 37
Digitizer Shield	“	“	8	D 37
Digitizer Ext Trigger	IFTE, TETS, RAF	“	8	D 38
Digitizer Shield	“	“	8	C 38
Digitizer TRIG OUT	ESTS, TETS, RAF	“	8	D 40
Digitizer Shield	“	“	8	C 40
Digitizer dc CAL	CASS	“	8	C 39
Digitizer Shield	“	“	8	D 39
Digitizer Wavfm Digtzr ChA	IFTE, CASS, LM-STAR, ESTS, TETS, IAIS, RAF	Max voltage: 250 V max Max current 140 mA Max freq: 500 MHz @ 50 $\Omega$	8	C 41
Digitizer Shield	“	“	8	D 41
Digitizer Wavfm Digtzr ChB	“	“	8	D 42
Digitizer Shield	“	“	8	C 42

**Table A.9—DMM**

CTI name	Legacy systems	Recommended attributes	Slot	Pin
DMM HI	IFTE, CASS, LM-STAR, ESTS, TETS, IAIS, C17, RAF	Max voltage: $\pm 300\text{V}$ Max freq: 100 kHz Max current: 3A	8	A 41
DMM HI Shield	IFTE, CASS, ESTS, TETS, C17	“	8	B 41
DMM LO	IFTE, CASS, LM-STAR, ESTS, TETS, IAIS, C17, RAF	“	8	B 42
DMM LO Shield	IFTE, CASS, ESTS, TETS, C17	“	8	A 42
DMM S(+)	IFTE, CASS, LM-STAR, ESTS, TETS, IAIS, C17, RAF	“	8	A 43
DMM S(+) Shield	IFTE, CASS, ESTS, TETS, C17	“	8	B 43
DMM S(-)	IFTE, CASS, LM-STAR, ESTS, TETS, IAIS, C17, RAF	“	8	B 44
DMM S(-) Shield	IFTE, CASS, ESTS, TETS, C17	“	8	A 44
DMM GUARD	CASS, LM-STAR, TEST, IAIS, C17	“	8	A 48
DMM CURRENT	CASS, LM-STAR, TEST, IAIS, RAF	“	8	B 48
DMM TRIG	ESTS, TETS, C17, RAF	Impedance: 1 M $\Omega$	8	A 45
DMM TRIG shd	“	Impedance 1 M $\Omega$	8	B 45
DMM Probe (+)	CASS, C17	Impedance 1 M $\Omega$	8	B 46
DMM Probe (-)	CASS, C17	Impedance 1 M $\Omega$	8	A 46
DMM DMM Done (+)	TETS, RAF	TTL Impedance: 1 M $\Omega$	8	A 47
DMM DMM Done (-)	TETS	TTL Impedance: 1 M $\Omega$	8	B 47

**Table A.10—Frequency interval counter and RF counter**

CTI name	Legacy systems	Recommended attributes	Slot	Pin
FTIC CH A	IFTE, CASS, LM-STAR, ESTS, TETS, IAIS, C17, RAF	Max voltage $\pm 10$ V Max freq: 220 MHz Impedance: 50 $\Omega$	8	C 9
FTIC Shield	“	“	8	D 9
FTIC CH B	“	“	8	D 10
FTIC Shield	“	“	8	C 10
FTIC Trig/Gate	IFTE, CASS, LM-STAR, ESTS, TETS, IAIS, RAF	“	8	C 11
FTIC Shield	“	“	8	D 11
RFCTR - Inh	ESTS	Max voltage $\pm 10$ V Max freq: 220 MHz Impedance: 50 $\Omega$ and 1 M $\Omega$	21,22	B 13
RFCTR - Thrshld	“	“	21,22	C 13

**Table A.11—Low-frequency calibrator**

CTI name	Legacy systems	Recommended attributes	Slot	Pin
Low Freq CAL HI	CASS	Max voltage: 200 Vdc Max current: 50 mA Max freq: 1.19 MHz and Max voltage: 200 Vrms Max current: 2.2 Arms Max freq: 1 kHz	9	C 39
Low Freq CAL LO	“	“	9	D 39
Low Freq Cal Shield	“	“	9	D 40
Low Freq CAL S+	“	Max voltage: 200 Vdc Max freq: 1.19 MHz and Max voltage: 200 Vrms Max freq: 1 kHz	9	C 40
Low Freq CAL S-	“	“	9	C 41
Low Freq Cal Guard	“	“	9	D 41

**Table A.12—Open collector driver**

CTI name	Legacy systems	Recommended attributes	Slot	Pin
Open Collector driver CH 1 (+)	LM-STAR, TETS, IAIS, C17	Max voltage: 60 V Max current: 1 A	7	A 5
Open Collector driver CH 1 (–)	“	“	7	B 5
Open Collector driver CH 2 (+)	“	“	7	B 6
Open Collector driver CH 2 (–)	“	“	7	A 6
Open Collector driver CH 3 (+)	“	“	7	A 7
Open Collector driver CH 3 (–)	“	“	7	B 7
Open Collector driver CH 4 (+)	“	“	7	B 8
Open Collector driver CH 4 (–)	“	“	7	A 8
Open Collector driver CH 5 (+)	“	“	7	A 9
Open Collector driver CH 5 (–)	“	“	7	B 9
Open Collector driver CH 6 (+)	“	“	7	B 10
Open Collector driver CH 6 (–)	“	“	7	A 10
Open Collector driver CH 7 (+)	“	“	7	A 11
Open Collector driver CH 7 (–)	“	“	7	B 11
Open Collector driver CH 8 (+)	“	“	7	B 12
Open Collector driver CH 8 (–)	“	“	7	A 12
Open Collector driver CH 9 (+)	“	“	7	A 13
Open Collector driver CH 9 (–)	“	“	7	B 13
Open Collector driver CH 10 (+)	“	“	7	B 14
Open Collector driver CH 10 (–)	“	“	7	A 14
Open Collector driver CH 11 (+)	“	“	7	A 15
Open Collector driver CH 11 (–)	“	“	7	B 15
Open Collector driver CH 12 (+)	“	“	7	B 16
Open Collector driver CH 12 (–)	“	“	7	A 16
Open Collector driver CH 13 (+)	“	“	7	C 5
Open Collector driver CH 13 (–)	“	“	7	D 5
Open Collector driver CH 14 (+)	“	“	7	D 6
Open Collector driver CH 14 (–)	“	“	7	C 6
Open Collector driver CH 15 (+)	“	“	7	C 7
Open Collector driver CH 15 (–)	“	“	7	D 7
Open Collector driver CH 16 (+)	“	“	7	D 8
Open Collector driver CH 16 (–)	“	“	7	C 8
Open Collector driver CH 17 (+)	“	“	7	C 9
Open Collector driver CH 17 (–)	“	“	7	D 9
Open Collector driver CH 18 (+)	“	“	7	D 10
Open Collector driver CH 18 (–)	“	“	7	C 10
Open Collector driver CH 19 (+)	“	“	7	C 11
Open Collector driver CH 19 (–)	“	“	7	D 11
Open Collector driver CH 20 (+)	“	“	7	D 12
Open Collector driver CH 20 (–)	“	“	7	C 12
Open Collector driver CH 21 (+)	“	“	7	C 13
Open Collector driver CH 21 (–)	“	“	7	D 13
Open Collector driver CH 22 (+)	“	“	7	D 14
Open Collector driver CH 22 (–)	“	“	7	C 14
Open Collector driver CH 23 (+)	“	“	7	C 15
Open Collector driver CH 23 (–)	“	“	7	D 15
Open Collector driver CH 24 (+)	“	“	7	D 16
Open Collector driver CH 24 (–)	“	“	7	C 16
Open Collector driver CH 25 (+)	“	“	19	A 1
Open Collector driver CH 25 (–)	“	“	19	B 1
Open Collector driver CH 26 (+)	“	“	19	B 2
Open Collector driver CH 26 (–)	“	“	19	A 2
Open Collector driver CH 27 (+)	“	“	19	A 3



Table A.12—Open collector driver (continued)

CTI name	Legacy systems	Recommended attributes	Slot	Pin
Open Collector driver CH 27 (–)	“	“	19	B 3
Open Collector driver CH 28 (+)	“	“	19	B 4
Open Collector driver CH 28 (–)	“	“	19	A 4
Open Collector driver CH 29 (+)	“	“	19	A 5
Open Collector driver CH 29 (–)	“	“	19	B 5
Open Collector driver CH 30 (+)	“	“	19	B 6
Open Collector driver CH 30 (–)	“	“	19	A 6
Open Collector driver CH 31 (+)	“	“	19	A 7
Open Collector driver CH 31 (–)	“	“	19	B 7
Open Collector driver CH 32 (+)	LM-STAR, IAIS, C17	“	19	B 8
Open Collector driver CH 32 (–)	“	“	19	A 8
Open Collector driver CH 33 (+)	“	“	19	A 9
Open Collector driver CH 33 (–)	“	“	19	B 9
Open Collector driver CH 34 (+)	“	“	19	B 10
Open Collector driver CH 34 (–)	“	“	19	A 10
Open Collector driver CH 35 (+)	“	“	19	A 11
Open Collector driver CH 35 (–)	“	“	19	B 11
Open Collector driver CH 36 (+)	“	“	19	B 12
Open Collector driver CH 36 (–)	“	“	19	A 12
Open Collector driver CH 37 (+)	“	“	19	A 13
Open Collector driver CH 37 (–)	“	“	19	B 13
Open Collector driver CH 38 (+)	“	“	19	B 14
Open Collector driver CH 38 (–)	“	“	19	A 14
Open Collector driver CH 39 (+)	“	“	19	A 15
Open Collector driver CH 39 (–)	“	“	19	B 15
Open Collector driver CH 40 (+)	“	“	19	B 16
Open Collector driver CH 40 (–)	“	“	19	A 16
Open Collector driver CH 41 (+)	“	“	19	C 1
Open Collector driver CH 41 (–)	“	“	19	D 1
Open Collector driver CH 42 (+)	“	“	19	D 2
Open Collector driver CH 42 (–)	“	“	19	C 2
Open Collector driver CH 43 (+)	“	“	19	C 3
Open Collector driver CH 43 (–)	“	“	19	D 3
Open Collector driver CH 44 (+)	“	“	19	D 4
Open Collector driver CH 44 (–)	“	“	19	C 4
Open Collector driver CH 45 (+)	“	“	19	C 5
Open Collector driver CH 45 (–)	“	“	19	D 5
Open Collector driver CH 46 (+)	“	“	19	D 6
Open Collector driver CH 46 (–)	“	“	19	C 6
Open Collector driver CH 47 (+)	“	“	19	C 7
Open Collector driver CH 47 (–)	“	“	19	D 7
Open Collector driver CH 48 (+)	“	“	19	D 8
Open Collector driver CH 48 (–)	“	“	19	C 8
Open Collector driver CH 49 (+)	“	“	19	C 9
Open Collector driver CH 49 (–)	“	“	19	D 9
Open Collector driver CH 50 (+)	“	“	19	D 10
Open Collector driver CH 50 (–)	“	“	19	C 10
Open Collector driver CH 51 (+)	“	“	19	C 11
Open Collector driver CH 51 (–)	“	“	19	D 11
Open Collector driver CH 52 (+)	“	“	19	D 12
Open Collector driver CH 52 (–)	“	“	19	C 12
Open Collector driver CH 53 (+)	“	“	19	C 13
Open Collector driver CH 53 (–)	“	“	19	D 13

**Table A.12—Open collector driver (continued)**

CTI name	Legacy systems	Recommended attributes	Slot	Pin
Open Collector driver CH 54 (+)	“	“	19	D 14
Open Collector driver CH 54 (–)	“	“	19	C 14
Open Collector driver CH 55 (+)	“	“	19	C 15
Open Collector driver CH 55 (–)	“	“	19	D 15
Open Collector driver CH 56 (+)	“	“	19	D 16
Open Collector driver CH 56 (–)	“	“	19	C 16
Open Collector driver CH 57 (+)	“	“	20	A 1
Open Collector driver CH 57 (–)	“	“	20	B 1
Open Collector driver CH 58 (+)	“	“	20	B 2
Open Collector driver CH 58 (–)	“	“	20	A 2
Open Collector driver CH 59 (+)	“	“	20	A 3
Open Collector driver CH 59 (–)	“	“	20	B 3
Open Collector driver CH 60 (+)	“	“	20	B 4
Open Collector driver CH 60 (–)	“	“	20	A 4
Open Collector driver CH 61 (+)	“	“	20	A 5
Open Collector driver CH 61 (–)	“	“	20	B 5
Open Collector driver CH 62 (+)	“	“	20	B 6
Open Collector driver CH 62 (–)	“	“	20	A 6
Open Collector driver CH 63 (+)	“	“	20	A 7
Open Collector driver CH 63 (–)	“	“	20	B 7
Open Collector driver CH 64 (+)	“	“	20	B 8
Open Collector driver CH 64 (–)	“	“	20	A 8
Open Collector driver CH 65 (+)	LM-STAR, IAIS	“	20	A 9
Open Collector driver CH 65 (–)	“	“	20	B 9
Open Collector driver CH 66 (+)	“	“	20	B 10
Open Collector driver CH 66 (–)	“	“	20	A 10
Open Collector driver CH 67 (+)	“	“	20	A 11
Open Collector driver CH 67 (–)	“	“	20	B 11
Open Collector driver CH 68 (+)	“	“	20	B 12
Open Collector driver CH 68 (–)	“	“	20	A 12
Open Collector driver CH 69 (+)	“	“	20	A 13
Open Collector driver CH 69 (–)	“	“	20	B 13
Open Collector driver CH 70 (+)	“	“	20	B 14
Open Collector driver CH 70 (–)	“	“	20	A 14
Open Collector driver CH 71 (+)	“	“	20	A 15
Open Collector driver CH 71 (–)	“	“	20	B 15
Open Collector driver CH 72 (+)	“	“	20	B 16
Open Collector driver CH 72 (–)	“	“	20	A 16
Open Collector driver CH 73 (+)	“	“	20	C 1
Open Collector driver CH 73 (–)	“	“	20	D 1
Open Collector driver CH 74 (+)	“	“	20	D 2
Open Collector driver CH 74 (–)	“	“	20	C 2
Open Collector driver CH 75 (+)	“	“	20	C 3
Open Collector driver CH 75 (–)	“	“	20	D 3
Open Collector driver CH 76 (+)	“	“	20	D 4
Open Collector driver CH 76 (–)	“	“	20	C 4
Open Collector driver CH 77 (+)	“	“	20	C 5
Open Collector driver CH 77 (–)	“	“	20	D 5
Open Collector driver CH 78 (+)	“	“	20	D 6
Open Collector driver CH 78 (–)	“	“	20	C 6
Open Collector driver CH 79 (+)	“	“	20	C 7
Open Collector driver CH 79 (–)	“	“	20	D 7
Open Collector driver CH 80 (+)	“	“	20	D 8

Table A.12—Open collector driver (continued)

CTI name	Legacy systems	Recommended attributes	Slot	Pin
Open Collector driver CH 80 (-)	“	“	20	C 8
Open Collector driver CH 81 (+)	“	“	20	C 9
Open Collector driver CH 81 (-)	“	“	20	D 9
Open Collector driver CH 82 (+)	“	“	20	D 10
Open Collector driver CH 82 (-)	“	“	20	C 10
Open Collector driver CH 83 (+)	“	“	20	C 11
Open Collector driver CH 83 (-)	“	“	20	D 11
Open Collector driver CH 84 (+)	“	“	20	D 12
Open Collector driver CH 84 (-)	“	“	20	C 12
Open Collector driver CH 85 (+)	“	“	20	C 13
Open Collector driver CH 85 (-)	“	“	20	D 13
Open Collector driver CH 86 (+)	“	“	20	D 14
Open Collector driver CH 86 (-)	“	“	20	C 14
Open Collector driver CH 87 (+)	“	“	20	C 15
Open Collector driver CH 87 (-)	“	“	20	D 15
Open Collector driver CH 88 (+)	“	“	20	D 16
Open Collector driver CH 88 (-)	“	“	20	C 16
Open Collector driver CH 89 (+)	“	“	27	B 28
Open Collector driver CH 89 (-)	“	“	27	A 28
Open Collector driver CH 90 (+)	“	“	27	A 29
Open Collector driver CH 90 (-)	“	“	27	B 29
Open Collector driver CH 91 (+)	“	“	27	B 30
Open Collector driver CH 91 (-)	“	“	27	A 30
Open Collector driver CH 92 (+)	“	“	27	A 31
Open Collector driver CH 92 (-)	“	“	27	B 31
Open Collector driver CH 93 (+)	“	“	27	B 32
Open Collector driver CH 93 (-)	“	“	27	A 32
Open Collector driver CH 94 (+)	“	“	27	A 33
Open Collector driver CH 94 (-)	“	“	27	B 33
Open Collector driver CH 95 (+)	“	“	27	B 34
Open Collector driver CH 95 (-)	“	“	27	A 34
Open Collector driver CH 96 (+)	“	“	27	A 35
Open Collector driver CH 96 (-)	“	“	27	B 35
Open Collector driver I/O*1-8	LM-STAR	TTL Levels	27	B 36
Open Collector driver I/O*9-16	“	TTL Levels	27	A 36
Open Collector driver I/O*17-24	“	TTL Levels	27	A 37
Open Collector driver I/O*25-32	“	TTL Levels	27	B 37
Open Collector driver I/O*33-40	“	TTL Levels	27	B 38
Open Collector driver I/O*41-48	“	TTL Levels	27	A 38
Open Collector driver I/O*49-56	“	TTL Levels	27	D 28
Open Collector driver I/O*57-64	“	TTL Levels	27	C 28
Open Collector driver I/O*65-72	“	TTL Levels	27	C 29
Open Collector driver I/O*73-80	“	TTL Levels	27	D 29
Open Collector driver I/O*81-88	“	TTL Levels	27	D 30
Open Collector driver I/O*89-96	“	TTL Levels	27	C 30
Open Collector driver I/O Return	“	TTL Levels	27	C 31
Open Collector driver CLK*1-8	“	TTL Levels	27	D 31
Open Collector driver CLK*9-16	“	TTL Levels	27	D 32
Open Collector driver CLK*17-24	“	TTL Levels	27	C 32
Open Collector driver CLK*25-32	“	TTL Levels	27	C 33
Open Collector driver CLK*33-40	“	TTL Levels	27	D 33

**Table A.12—Open collector driver (continued)**

CTI name	Legacy systems	Recommended attributes	Slot	Pin
Open Collector driver CLK*41-48	“	TTL Levels	27	D 34
Open Collector driver CLK*49-56	“	TTL Levels	27	C 34
Open Collector driver CLK*57-64	“	TTL Levels	27	C 35
Open Collector driver CLK*65-72	“	TTL Levels	27	D 35
Open Collector driver CLK*73-80	“	TTL Levels	27	D 36
Open Collector driver CLK*81-88	“	TTL Levels	27	C 36
Open Collector driver CLK*89-96	“	TTL Levels	27	C 37
Open Collector driver CLK Return	“		27	D 37

**Table A.13—Pulse generator**

CTI name	Legacy systems	Recommended attributes	Slot	Pin
Pulse Gen 1 ChA	CASS, LM-STAR, C17	Max voltage: $\pm 5V$ Max freq: 250 MHz	8	C 1
Pulse Gen 1 Shield	“		8	D 1
Pulse Gen 1 ChB	“	Max voltage: $\pm 5V$ Max freq: 250 MHz	8	D 2
Pulse Gen 1 Shield	“		8	C 2
Pulse Gen 1 Trig Out	“	Max voltage: TTL Max freq: 100 MHz	8	C 3
Pulse Gen 1 Shield	“		8	D 3
Pulse Gen 1 Trig In	“	Max voltage: $\pm 5V$ Max freq: 100 MHz	8	D 4
Pulse Gen 1 Shield	“		8	C 4

**Table A.14—Pulse generator 2**

CTI name	Legacy systems	Recommended attributes	Slot	Pin
Pulse Gen 2 ChA	LM-STAR	Max voltage: $\pm 5V$ Max freq: 250 MHz	8	C 5
Pulse Gen 2 Shield	“		8	D 5
Pulse Gen 2 ChB	“	Max voltage: $\pm 5V$ Max freq: 250 MHz	8	D 6
Pulse Gen 2 Shield	“		8	C 6
Pulse Gen 2 Trig Out	“	Max voltage: TTL Max freq: 100 MHz	8	C 7
Pulse Gen 2 Shield	“		8	D 7
Pulse Gen 2 Trig In	“	Max voltage: $\pm 10V$ Min Pulse: 3 ns	8	D 8
Pulse Gen 2 Shield	“		8	C 8

**Table A.15—Resistive load**

CTI name	Legacy systems	Recommended attributes	Slot	Pin
Resistive Load 1 (+)	CASS, LM-STAR, RAF	Maximum voltage: 200 V Max current: 500 mA Max power 5 W	9	A 41
Resistive Load 1 (-)	“	“	9	B 41

**Table A.16—Scope**

CTI name	Legacy system	Recommended attributes	Slot	Pin
Scope CH 1	LM-STAR, C17	BW: 1 GHz Max voltage: $\pm 250$ V	21,22	A 13
Scope CH 2	“	“	21,22	A 14
Scope CH 3	“	“	21,22	A 15
Scope CH 4	“	“	21,22	A 16
Scope AuxOut	“	Max voltage: $\pm 2.4$ V	21,22	A 17

**Table A.17—Synchro-resolver**

CTI name	Legacy systems	Recommended attributes	Slot	Pin
SYN1CRSE S1	IFTE, CASS, LM-STAR, ESTS, TETS, IAIS, C17	Max voltage: 90 Vrms Max current: 1.5 A Max freq: 1 kHz	18	A 16
SYN1CRSE S2	“	“	18	A 17
SYN1CRSE S3	“	“	18	A 18
SYN1CRSE S4	IFTE, CASS, ESTS, TETS, C17	“	18	A 19
SYN1Ind CRSE S1	IFTE, CASS, LM-STAR, ESTS, TETS, IAIS, C17	“	18	A 20
SYN1Ind CRSE S2	“	“	18	A 21
SYN1Ind CRSE S3	“	“	18	A 22
SYN1Ind CRSE S4	IFTE, CASS, ESTS, TETS, C17	“	18	A 23
SYN1Shield	IFTE, CASS, LM-STAR, ESTS, TETS, IAIS, C17	“	18	A 24
SYN1FINE S1	CASS, LM-STAR, TETS, IAIS, C17	“	18	A 25
SYN1FINE S2	“	“	18	A 26
SYN1FINE S3	“	“	18	A 27
SYN1FINE S4	CASS, TETS	“	18	A 28
SYN1Ind FINE S1	CASS, LM-STAR, TETS, IAIS, C17	“	18	A 29
SYN1Ind FINE S2	“	“	18	A 30
SYN1Ind FINE S3	“	“	18	A 31
Ext. Trigger (+)	ESTS	“	18	C 33
Ext. Trigger (-)	“	“	18	C 34
SYN1(EXT)Ref +	IFTE, CASS, LM-STAR, ESTS, TETS, IAIS, C17	Max voltage: 130 Vrms Max current: 1.5 A Max freq: 1 kHz	18	A 33

**Table A. 17—Synchro-resolver (continued)**

CTI name	Legacy systems	Recommended attributes	Slot	Pin
SYN1(EXT) Ref -	“	“	18	A34
SYN1IND FINE S4	“	“	18	A 32
SYN1 Ind Ref +	IFTE, CASS, ESTS, TETS, C17	“	18	A 35
SYN1 Ind Ref -	“	“	18	A36
SYN2Ind FINE S4	IFTE, CASS, ESTS, TETS, C17	“	18	B 32
SYN2Ind FINE S4	“	See above	18	D 28
SYN2 CRSE S1	CASS, LM-STAR, ESTS, TETS, IAIS	Max voltage: 90 Vrms Max current: 1.5 A Max freq: 1 kHz	18	B 16
SYN2 CRSE S2	“	“	18	B 17
SYN2 CRSE S3	“	“	18	B 18
SYN2 CRSE S4	CASS, ESTS, TETS,	“	18	B 19
SYN2 Ind CRSE S1	CASS, LM-STAR, ESTS, TETS, IAIS	“	18	B 20
SYN2 Ind CRSE S2	“	“	18	B 21
SYN2 Ind CRSE S3	“	“	18	B 22
SYN2 Ind CRSE S4	CASS, ESTS, TETS,	“	18	B 23
SYN2 Shield	CASS, LM-STAR, ESTS, TETS, IAIS	“	18	C 24
SYN2 FINE S1	CASS, LM-STAR, TETS, IAIS	“	18	B 25
SYN2 FINE S2	“	“	18	B 26
SYN2 FINE S3	“	“	18	B 27
SYN2 FINE S4	CASS, TETS	“	18	B 28
SYN2 Ind FINE S1	CASS, LM-STAR, TETS, IAIS	“	18	B 29
SYN2 Ind FINE S2	“	“	18	B 30
SYN2 Ind FINE S3	“	“	18	B 31
SYN2 Ext Ref +	CASS, LM-STAR, ESTS, TETS, IAIS	Max voltage: 130 Vrms Max current: 1.5 A Max freq: 1 kHz	18	B 34
SYN2 Ext Ref -	“	“	18	B 33
SYN2 Ind Ref +	CASS, ESTS, TETS	“	18	B 36
SYN2 Ind Ref -	“	“	18	B 35
SYN3 CRSE S1	CASS, LM-STAR, ESTS, IAIS	Max voltage: 90 Vrms Max current: 1.5 A Max freq: 1 kHz	18	C 21
SYN3 CRSE S2	“	“	18	C 22
SYN3 CRSE S3	“	“	18	C 23
SYN3 CRSE S4	CASS, ESTS	“	18	C 24
SYN3 Ind CRSE S1	CASS, LM-STAR, ESTS, IAIS	“	18	C 25
SYN3 Ind CRSE S2	“	“	18	C 26

**Table A.17—Synchro-resolver (continued)**

CTI name	Legacy systems	Recommended attributes	Slot	Pin
SYN3 Ind CRSE S3	“	“	18	C 27
SYN3 Ind CRSE S4	CASS, ESTS	“	18	C 28
SYN3 Shield	CASS, LM-STAR, ESTS, IAIS	“	18	D 29
SYN3 FINE S1	CASS, LM-STAR, IAIS	Max voltage: 90 Vrms Max current: 1.5 A Max freq: 1 kHz	18	D 21
SYN3 FINE S2	“	“	18	D 22
SYN3 FINE S3	“	“	18	D 23
SYN3 FINE S4	CASS	“	18	D 24
SYN3 Ind FINE S1	CASS, LM-STAR, IAIS	“	18	D 25
SYN3 Ind FINE S2	“	“	18	D 26
SYN3 Ind FINE S3	“	“	18	D 27
SYN3 Ext Ref +	CASS, LM-STAR, ESTS, IAIS	Max voltage: 130 Vrms Max current: 1.5 A Max freq: 1 kHz	18	C 29
SYN3 Ext Ref –	“	“	18	C 30
SYN3 Ind Ref +	CASS, ESTS	“	18	C 31
SYN3 Ind Ref –	“	“	18	C 32

**Table A.18—Video**

CTI name	Legacy systems	Recommended attributes	Slot	Pin
CLK ECL –	ESTS	100 Ω TSP PECL	26	C 18
CLK ECL +	“	100 Ω TSP PECL	26	D 18
DAS 1 Blue Stroke Z –	IFTE, ESTS, IAIS	75 Ω CX	26	B 5
DAS 1 Blue Stroke Z +	“	75 Ω CX	26	A 5
DAS 1 Blue Stroke Z S –	ESTS	100 Ω TSP PECL	26	A 24
DAS 1 Blue Stroke Z S	“	100 Ω TSP PECL	26	B 24
DAS 1 Green Stroke Y –	IFTE, ESTS, IAIS	75 Ω CX	26	C 4
DAS 1 Green Stroke Y +	“	75 Ω CX	26	D 4
DAS 1 Green Stroke Y S –	ESTS	100 Ω TSP PECL	26	C 22
DAS 1 Green Stroke Y S	“	100 Ω TSP PECL	26	D 22
DAS 1 Red Stroke X –	IFTE, ESTS, IAIS	75 Ω CX	26	D 3
DAS 1 Red Stroke X +	“	75 Ω CX	26	C 3
DAS 1 Red Stroke X S –	ESTS	100 Ω TSP PECL	26	D 21
DAS 1 Red Stroke X S +	“	100 Ω TSP PECL	26	C 21
DAS Blue Raster Vert –	IFTE, ESTS, IAIS	75 Ω CX	26	A 4
DAS Blue Raster Vert +	“	75 Ω CX	26	B 4
DAS Blue Vert S –	ESTS	100 Ω TSP PECL	26	A 22
DAS Blue Vert S +	“	100 Ω TSP PECL	26	B 22
DAS Green Raster Horiz –	IFTE, ESTS, IAIS	75 Ω CX	26	B 3
DAS Green Raster Horiz +	“	75 Ω CX	26	A 3
DAS Green S –	ESTS	100 Ω TSP PECL	26	B 21
DAS Green S +	“	100 Ω TSP PECL	26	A 21
DAS Red Horiz S –	“	100 Ω TSP PECL	26	D 19
DAS Red Horiz S +	“	100 Ω TSP PECL	26	C 19
DAS Red Raster Horiz –	IFTE, ESTS, IAIS	75 Ω CX	26	C 2
DAS Red Raster Horiz +	IFTE, ESTS	75 Ω CX	26	D 2
DAS RSIA Enable –	“	100 Ω TSP PECL	26	B 9
DAS RSIA Enable +	“	100 Ω TSP PECL	26	A 9
Det Field Out–	“	100 Ω TSP PECL	26	A 16
Det Field Out+	“	100 Ω TSP PECL	26	B 16
Det Vert Sync Out–	“	100 Ω TSP PECL	26	D 15



Table A.18—Video (continued)

CTI name	Legacy systems	Recommended attributes	Slot	Pin
Det Vert Sync Out+	“	100 $\Omega$ TSP PECL	26	C 15
Ext Cmp Vid Enable-	“	100 $\Omega$ TSP PECL	26	A 12
Ext Cmp Vid Enable+	“	100 $\Omega$ TSP PECL	26	B 12
Ext Horiz Sync In-	“	100 $\Omega$ TSP PECL	26	D 9
Ext Horiz Sync In+	“	100 $\Omega$ TSP PECL	26	C 9
Ext Ready Out-	“	100 $\Omega$ TSP PECL	26	D 13
Ext Ready Out+	“	100 $\Omega$ TSP PECL	26	C 13
Ext Stroke Gen Clk In-	“	100 $\Omega$ TSP PECL	26	B 13
Ext Stroke Gen Clk In+	“	100 $\Omega$ TSP PECL	26	A 13
Ext Stroke Trig In-	“	100 $\Omega$ TSP PECL	26	C 10
Ext Stroke Trig In+	“	100 $\Omega$ TSP PECL	26	D 10
Ext Sys Clk In-	“	100 $\Omega$ TSP PECL	26	C 12
Ext Sys Clk In+	“	100 $\Omega$ TSP PECL	26	D 12
Ext Vert Sync In-	“	100 $\Omega$ TSP PECL	26	A 10
Ext Vert Sync In+	“	100 $\Omega$ TSP PECL	26	B 10
Horiz Sync Out-	“	100 $\Omega$ TSP PECL	26	B 19
Horiz Sync Out+	“	100 $\Omega$ TSP PECL	26	A 19
Local Horiz Sync Out-	“	100 $\Omega$ TSP PECL	26	B 15
Local Horiz Sync Out+	“	100 $\Omega$ TSP PECL	26	A 15
System Clock Out-	“	100 $\Omega$ TSP PECL	26	C 16
System Clock Out+	“	100 $\Omega$ TSP PECL	26	D 16
Vert Sync Out-	“	100 $\Omega$ TSP PECL	26	A 18
Vert Sync Out+	“	100 $\Omega$ TSP PECL	26	B 18
Video CH 0-	“	75 $\Omega$ CX	26	B 1
Video CH 0+	“	75 $\Omega$ CX	26	A 1
Video CH 1-	“	75 $\Omega$ CX	26	A 2
Video CH 1+	“	75 $\Omega$ CX	26	B 2

**Table A.18—Video (continued)**

CTI name	Legacy systems	Recommended attributes	Slot	Pin
Video CH 2–	IAIS	75 Ω CX	26	D 1
Video CH 2+	“	75 Ω CX	26	C 1
Video CH 3–	“	75 Ω CX RS170–	26	B 7
Video CH 3+	“	75 Ω CX RS170+	26	A 7
Video CH 4–	“	SE2	26	D 7
Video CH 4+	“	SE1	26	C 7
Video CH 5–	“	SE	26	A 8
Video CH 5+	“	SE	26	B 8
Video CH 6–	“	SE	26	C 8
Video CH 6+	“	SE	26	D 8
Video CH 7–	“	100 Ω TSP	26	B 11
Video CH 7+	“	100 Ω TSP	26	A 11
Video CH 8–	“	100 Ω TSP	26	D 11
Video CH 8+	“	100 Ω TSP	26	C 11
Video CH 9–	“	100 Ω TSP	26	A 14
Video CH 9+	“	100 Ω TSP	26	B 14
Video CH 10–	“	100 Ω TSP	26	C 14
Video CH 10+	“	100 Ω TSP	26	D 14
Video CH 11–	“	100 Ω TSP	26	B 17
Video CH 11+	“	100 Ω TSP	26	A 17
Video CH 12–	“	100 Ω TSP	26	D 17
Video CH 12+	“	100 Ω TSP	26	C 17
Video CH 13–	“	100 Ω TSP	26	A 20
Video CH 13+	“	100 Ω TSP	26	B 20
Video CH 14–	“	100 Ω TSP	26	C 20
Video CH 14+	“	100 Ω TSP	26	D 20
Video CH 15–	“	100 Ω TSP	26	B 23
Video CH 15+	“	100 Ω TSP	26	A 23
Video CH 16–	“	100 Ω TSP	26	D 23
Video CH 16+	“	100 Ω TSP	26	C 23
Video CH 17–	“	100 Ω TSP PECL	26	A 30
Video CH 17+	“	100 Ω TSP PECL	26	B 30
Video CH 18–	“	100 Ω TSP	26	C 30
Video CH 18+	“	100 Ω TSP	26	D 30
Video CH 19–	“	100 Ω TSP PECL	26	B 31
Video CH 19+	“	100 Ω TSP PECL	26	A 31
Video CH 20–	“	100 Ω TSP	26	D 31
Video CH 20+	“	100 Ω TSP	26	C 31
Video CH 21–	“	100 Ω TSP	26	A 32
Video CH 21+	“	100 Ω TSP	26	B 32
Video CH 22–	“	100 Ω TSP	26	C 32
Video CH 22+	“	100 Ω TSP	26	D 32
Video CH 23–	“	100 Ω TSP PECL	26	B 33
Video CH 23+	“	100 Ω TSP PECL	26	A 33
Video CH 24–	“	100 Ω TSP PECL	26	D 33

Table A.18—Video (continued)

CTI name	Legacy systems	Recommended attributes	Slot	Pin
Video CH 24+	“	100 Ω TSP PECL	26	C 33
Video CH 25–	“	100 Ω TSP PECL	26	A 34
Video CH 25+	“	100 Ω TSP PECL	26	B 34
Video CH 26–	“	100 Ω TSP PECL	26	C 34
Video CH 26+	“	100 Ω TSP PECL	26	D 34
Video CH 27–	“	100 Ω TSP	26	B 35
Video CH 27+	“	100 Ω TSP	26	A 35
Video CH 28–	“	100 Ω TSP	26	D 35
Video CH 28+	“	100 Ω TSP	26	C 35
Video CH 29–	“	120 Ω TX PECL	26	A 36
Video CH 29+	“	120 Ω TX PECL	26	B 36
Video CH 30–	“	120 Ω TX	26	C 36
Video CH 30+	“	120 Ω TX	26	D 36
Video CH 31–	“	120 Ω TX 30 Hz PECL	26	B 37
Video CH 31+	“	120 Ω TX2+ 30 Hz PECL	26	A 37
Video CH 32–	“	120 Ω TX	26	D 37
Video CH 32+	“	120 Ω TX	26	C 37
Video CH 33–	“	120 Ω TX	26	A 38
Video CH 33+	“	120 Ω TX	26	B 38
Video CH 34–	“	120 Ω TX	26	C 38
Video CH 34+	“	120 Ω TX	26	D 38
Video CH 35–	“	120 Ω TX	26	B 39
Video CH 35+	“	120 Ω TX	26	A 39
Video CH 36–	“	120 Ω TX	26	D 39
Video CH 36+	“	120 Ω TX	26	C 39
Video CH 37–	“	120 Ω TX	26	A 40
Video CH 37+	“	120 Ω TX	26	B 40
Video CH 38–	“	120 Ω TX	26	C 40
Video CH 38+	“	120 Ω TX	26	D 40
Video CH 39–	“	120 Ω TX	26	B 41
Video CH 39+	“	120 Ω TX	26	A 41
Video CH 40–	“	120 Ω TX	26	D 41
Video CH 40+	“	120 Ω TX	26	C 41
Video CH 41–	“	120 Ω TX	26	A 42
Video CH 41+	“	120 Ω TX	26	B 42
Video CH 42–	“	120 Ω TX	26	C 42
Video CH 42+	“	120 Ω TX	26	D 42
Video CH 43–	“	120 Ω TX	26	B 43
Video CH 43+	“	120 Ω TX	26	A 43
Video CH 44–	“	120 Ω TX	26	D 43
Video CH 44+	“	120 Ω TX	26	C 43
Video CH 45–	“	120 Ω TX	26	A 44
Video CH 45+	“	120 Ω TX	26	B 44

**Table A.18—Video (continued)**

CTI name	Legacy systems	Recommended attributes	Slot	Pin
Video CH 46–	“	120 Ω TX	26	C 44
Video CH 46+	“	120 Ω TX	26	D 44
Video CH 47–	“	120 Ω TX	26	B 45
Video CH 47+	“	120 Ω TX	26	A 45
Video CH 48–	“	120 Ω TX	26	D 45
Video CH 48+	“	120 Ω TX	26	C 45
Video CH 49–	“	120 Ω TX	26	A 46
Video CH 49+	“	120 Ω TX	26	B 46
Video CH 50–	“	120 Ω TX	26	C 46
Video CH 50+	“	120 Ω TX	26	D 46
Video CH 51–	“	120 Ω TX	26	B 47
Video CH 51+	“	120 Ω TX	26	A 47
Video CH 52–	“	120 Ω TX	26	D 47
Video CH 52+	“	120 Ω TX	26	C 47
Video CH 53–	“	120 Ω TX	26	A 48
Video CH 53+	“	120 Ω TX	26	B 48
Video CH 54–	“	SE	26	C 48
Video CH 54+	“	SE	26	D 48
Video CH 55–	“	120 Ω TX	26	B 49
Video CH 55+	“	120 Ω TX	26	A 49
Video CH 56–	“	SE	26	D 49
Video CH 56+	“	SE	26	C 49
Video CH 57–	“	120 Ω TX	26	A 50
Video CH 57+	“	120 Ω TX	26	B 50
Video CH 58–	“	SE	26	C 50
Video CH 58+	“	SE	26	D 50
Video CH 59–	“	75 Ω CX	26	D 5
Video CH 59+	IFTE, ESTS	75 Ω CX	26	C 5
Video CH 60–	“	75 Ω CX	26	A 6
Video CH 60+	IFTE, ESTS	75 Ω CX	26	B 6
Video shield	“	75 Ω CX	26	D 6
VPG blue analog video return	CASS	100 Ω TSP PECL	26	B 27
VPG blue analog video	“	100 Ω TSP PECL	26	A 27
VPG green analog video return	“	100 Ω TSP	26	C 26
VPG green analog video	“	100 Ω TSP	26	D 26
VPG Horizontal Composite SYNC HI	“	100 Ω TSP PECL	26	A 25
VPG Horizontal Composite SYNC LO	“	100 Ω TSP PECL	26	B 25
VPG NTSC or PAL television return	“	100 Ω TSP PECL	26	C 24
VPG NTSC or PAL television	“	100 Ω TSP PECL	26	D 24
VPG red analog video return	“	100 Ω TSP	26	A 26
VPG red analog video	“	100 Ω TSP	26	B 26
VPG trigger HI	“	100 Ω TSP	26	C 29
VPG trigger LO	“	100 Ω TSP	26	D 29
VPG TTL blue intensity	“	100 Ω TSP	26	C 28
VPG TTL blue	“	100 Ω TSP	26	D 28
VPG TTL green intensity	“	100 Ω TSP PECL	26	A 28
VPG TTL green	“	100 Ω TSP PECL	26	B 28

**Table A.18—Video (continued)**

CTI name	Legacy systems	Recommended attributes	Slot	Pin
VPG TTL ground	IFTE, CASS, ESTS	75 $\Omega$ CX	26	C 6
VPG TTL horizontal SYNC	CASS	100 $\Omega$ TSP PECL	26	A 29
VPG TTL red intensity	“	100 $\Omega$ TSP	26	D 27
VPG TTL red	“	100 $\Omega$ TSP	26	C 27
VPG TTL vertical SYNC	“	100 $\Omega$ TSP PECL	26	B 29
VPG vertical SYNC HI	“	100 $\Omega$ TSP PECL	26	C 25
VPG vertical SYNC LO	“	100 $\Omega$ TSP PECL	26	D 25

**Table A.19—Programmable bus**

CTI name	Legacy system	Recommended attributes	Slot	Pin
Comm Bus 1 CH A+	IFTE, CASS, ESTS, TETS, C17, RAF	Function: 1553\CAN+ Voltage: $\pm 25$ V Freq: 500 MHz Impedance: 100 $\Omega$	7	A 33
Comm Bus 1 CH A-	CASS, C17, RAF	“	7	B 33
Comm Bus 1553 GND	CASS, SAME, ESTS, TETS, C17	“	7	A 49
Comm Bus 1 CH B+	IFTE, CASS, ESTS, TETS, C17, RAF	Function: 1553\CAN- Voltage: $\pm 25$ V Freq: 500 MHz Impedance: 100 $\Omega$	7	B 34
Comm Bus 1 CH B-	CASS, C17, RAF	“	7	A 34
Comm Bus 1553 GND	CASS, SAME, ESTS, TETS, C17	“	7	B 49
Comm Bus 1 CH C+	CASS, ESTS, RAF	Function: Programmable Voltage: $\pm 25$ V Freq: 500 MHz Impedance: 100 $\Omega$	7	A 35
Comm Bus 1 CH C-	CASS, ESTS	“	7	B 35
Comm Bus 1 CH D+	CASS, ESTS, RAF	“	7	B 36
Comm Bus 1 CH D-	CASS, ESTS	“	7	A 36
Comm Bus 1 CH E+	IFTE, CASS, ESTS, RAF	“	7	A 37
Comm Bus 1 CH E-	CASS	“	7	B 37
Comm Bus 1 CH F+	IFTE, CASS, ESTS, RAF	“	7	B 38
Comm Bus 1 CH F-	CASS	“	7	A 38
Comm Bus 1 CH G+	CASS, ESTS, RAF	“	7	A 39
Comm Bus 1 CH G-	CASS, ESTS	“	7	B 39
Comm Bus 1 CH H+	CASS, RAF	“	7	B 40
Comm Bus 1 CH H-	CASS	“	7	A 40
Comm Bus 2 CH A+	IFTE, CASS, C17, RAF	Function: MIC\UBIC BUS A+ Voltage: $\pm 25$ V Freq: 500 MHz Impedance: 100 $\Omega$	7	A 41

**Table A.19—Programmable bus (continued)**

CTI name	Legacy system	Recommended attributes	Slot	Pin
Comm Bus 2 CH A–	CASS, SAME, C17	“	7	B 41
Comm Bus 2 CH B+	IFTE, CASS, SAME, C17	Function: MIC\UBIC BUS A– Voltage: ± 25 V Freq: 500 MHz Impedance: 100 Ω	7	B 42
Comm Bus 2 CH B–	CASS, SAME, C17	“	7	A 42
Comm Bus 2 CH C+	IFTE, CASS, SAME, ESTS	Function: Programmable Voltage: ± 25 V Freq: 500 MHz Impedance: 100 Ω	7	A 43
Comm Bus 2 CH C–	CASS, SAME, ESTS	“	7	B 43
Comm Bus 2 CH D+	IFTE, CASS, SAME, ESTS	“	7	B 44
Comm Bus 2 CH D–	CASS, SAME, ESTS	“	7	A 44
Comm Bus 2 CH E+	CASS, SAME	Function: MIC\UBIC BUS B+ Voltage: ± 25 V Freq: 500 MHz Impedance: 100 Ω	7	A 45
Comm Bus 2 CH E–	“	“	7	B 45
Comm Bus 2 CH F+	IFTE, CASS, SAME	Function: MIC\UBIC BUS B– Voltage: ± 25 V Freq: 500 MHz Impedance: 100 Ω	7	B 46
Comm Bus 2 CH F–	CASS, SAME	“	7	A 46
Comm Bus 2 CH G+	IFTE, CASS, SAME, ESTS	Function: Programmable Voltage: ± 25 V Freq: 500 MHz Impedance: 100 Ω	7	A 47
Comm Bus 2 CH G–	CASS, SAME, ESTS	“	7	B 47
Comm Bus 2 CH H+	CASS, SAME	“	7	B 48
Comm Bus 2 CH H–	CASS, SAME	“	7	A 48
Comm Bus 3 CH A+	CASS, SAME, C17	Function: Programmable Voltage: ± 25 V Freq: 500 MHz Impedance: 70 Ω	7	C 33
Comm Bus 3 CH A–	“	“	7	D 33
Comm Bus 3 CH B+	“	“	7	D 34
Comm Bus 3 CH B–	“	“	7	C 34
Comm Bus 3 CH C+	CASS, SAME	“	7	C 35
Comm Bus 3 CH C–	“	“	7	D 35
Comm Bus 3 CH D+	“	“	7	D 36
Comm Bus 3 CH D–	“	“	7	C 36
Comm Bus 3 CH E+	SAME	“	7	C 37
Comm Bus 3 CH E–	CASS, SAME	“	7	D 37
Comm Bus 3 CH F+	SAME, ESTS	“	7	D 38
Comm Bus 3 CH F–	CASS, SAME, ESTS	“	7	C 38
Comm Bus 3 CH G+	SAME, ESTS	“	7	C 39
Comm Bus 3 CH G–	CASS, SAME	“	7	D 39
Comm Bus 3 CH H+	SAME, ESTS	“	7	D 40
Comm Bus 3 CH H–	CASS, SAME	“	7	C 40

**Table A.19—Programmable bus (continued)**

CTI name	Legacy system	Recommended attributes	Slot	Pin
Comm Bus 4 CH A+	IFTE, SAME, ESTS, TETS, C17	Function: CAN+ Voltage: $\pm 25$ V Freq: 500 MHz Impedance: 100 $\Omega$	7	C 41
Comm Bus 4 CH A–	CASS, SAME, C17	“	7	D 41
Comm Bus 4 CH B+	IFTE, SAME, ESTS, TETS, C17	Function: CAN– Voltage: $\pm 25$ V Freq: 500 MHz Impedance: 100 $\Omega$	7	D 42
Comm Bus 4 CH B–	CASS, SAME, C17	“	7	C 42
Comm Bus 4 CH C+	SAME, ESTS, C17	Function: Programmable Voltage: $\pm 25$ V Freq: 500 MHz Impedance: 100 $\Omega$	7	C 43
Comm Bus 4 CH C–	CASS, SAME, ESTS, C17	“	7	D 43
Comm Bus 4 CH D+	ESTS	“	7	D 44
Comm Bus 4 CH D–		“	7	C 44
Comm Bus 4 CH E+	IFTE, ESTS	“	7	C 45
Comm Bus 4 CH E–		“	7	D 45
Comm Bus 4 CH F+	IFTE, ESTS	“	7	D 46
Comm Bus 4 CH F–		“	7	C 46
Comm Bus 4 CH G+	CASS, ESTS	“	7	C 47
Comm Bus 4 CH G–	“	“	7	D 47
Comm Bus 4 CH H+	“	“	7	D 48
Comm Bus 4 CH H–	CASS	“	7	C 48
Comm Bus 5 CH A+	CASS, LM-STAR, IAIS, C17	Function: MIC\UBIC BUS A+ Voltage: $\pm 25$ V Freq: 500 MHz Impedance: 100 $\Omega$	28	A 1
Comm Bus 5 CH A–	“	“	28	B 1
Comm Bus 1553 GND		“	7	C 49
Comm Bus 5 CH B+	“	Function: MIC\UBIC BUS A– Voltage: $\pm 25$ V Freq: 500 MHz Impedance: 100 $\Omega$	28	B 2
Comm Bus 5 CH B–	“	“	28	A 2
Comm Bus 1553 GND		Function: Programmable Voltage: $\pm 25$ V Freq: 500 MHz Impedance: 100 $\Omega$	7	D 49

**Table A.19—Programmable bus (continued)**

CTI name	Legacy system	Recommended attributes	Slot	Pin
Comm Bus 5 CH C+	CASS, LM-STAR, IAIS	“	28	A 3
Comm Bus 5 CH C–	“	“	28	B 3
Comm Bus 5 CH D+	“	“	28	B 4
Comm Bus 5 CH D–	“	“	28	A 4
Comm Bus 5 CH E+	“	Function: MIC\UBIC BUS B+ Voltage: ± 25 V Freq: 500 MHz Impedance: 100 Ω	28	A 5
Comm Bus 5 CH E–	“	“	28	B 5
Comm Bus 5 CH F+	“	Function: MIC\UBIC BUS B– Voltage: ± 25 V Freq: 500 MHz Impedance: 100 Ω	28	B 6
Comm Bus 5 CH F–	“	“	28	A 6
Comm Bus 5 CH G+	“	Function: Programmable Voltage: ± 25 V Freq: 500 MHz Impedance: 100 Ω	28	A 7
Comm Bus 5 CH G–	“	“	28	B 7
Comm Bus 5 CH H+	“	“	28	B 8
Comm Bus 5 CH H–	“	“	28	A 8
Comm Bus 6 CH A+	CASS, LM-STAR, IAIS, C17	Function: Programmable Voltage: ± 25 V Freq: 500 MHz Impedance: 70 Ω	28	A 9
Comm Bus 6 CH A–	“	“	28	B 9
Comm Bus 6 CH B+	“	“	28	B 10
Comm Bus 6 CH B–	“	“	28	A 10
Comm Bus 6 CH C+	“	“	28	A 11
Comm Bus 6 CH C–	“	“	28	B 11
Comm Bus 6 CH D+	CASS, LM-STAR, IAIS	“	28	B 12
Comm Bus 6 CH D–	“	“	28	A 12
Comm Bus 6 CH E+	“	“	28	A 13
Comm Bus 6 CH E–	“	“	28	B 13
Comm Bus 6 CH F+	“	“	28	B 14
Comm Bus 6 CH F–	“	“	28	A 14
Comm Bus 6 CH G+	“	“	28	A 15
Comm Bus 6 CH G–	“	“	28	B 15
Comm Bus 6 CH H+	“	“	28	B 16
Comm Bus 6 CH H–	“	“	28	A 16
Comm Bus 7 CH A+	CASS, LM-STAR, IAIS, C17	“	28	C 1
Comm Bus 7 CH A–	“	“	28	D 1
Comm Bus 7 CH B+	“	“	28	D 2
Comm Bus 7 CH B–	“	“	28	C 2
Comm Bus 7 CH C+	“	Function: Programmable Voltage: ± 25 V Freq: 500 MHz Impedance: 100 Ω	28	C 3
Comm Bus 7 CH C–	“	“	28	D 3



**Table A.19—Programmable bus (continued)**

CTI name	Legacy system	Recommended attributes	Slot	Pin
Comm Bus 7 CH D+	CASS, LM-STAR, IAIS	“	28	D 4
Comm Bus 7 CH D-	“	“	28	C 4
Comm Bus 7 CH E+	LM-STAR, IAIS	Function: Programmable Voltage: $\pm 25$ V Freq: 500 MHz Impedance: 100 $\Omega$	28	C 5
Comm Bus 7 CH E-	CASS, LM-STAR, IAIS	“	28	D 5
Comm Bus 7 CH F+	LM-STAR, IAIS	“	28	D 6
Comm Bus 7 CH F-	CASS, LM-STAR, IAIS	“	28	C 6
Comm Bus 7 CH G+	LM-STAR, IAIS	“	28	C 7
Comm Bus 7 CH G-	“	“	28	D 7
Comm Bus 7 CH H+	“	“	28	D 8
Comm Bus 7 CH H-	“	“	28	C 8
Comm Bus 8 CH A+	“	“	28	C 9
Comm Bus 8 CH A-	“	“	28	D 9
Comm Bus 8 CH B+	“	“	28	D 10
Comm Bus 8 CH B-	“	“	28	C 10
Comm Bus 8 CH C+	“	“	28	C 11
Comm Bus 8 CH C-	“	“	28	D 11
Comm Bus 8 CH D+	“	“	28	D 12
Comm Bus 8 CH D-	“	“	28	C 12
Comm Bus 8 CH E+	“	“	28	C 13
Comm Bus 8 CH E-	“	“	28	D 13
Comm Bus 8 CH F+	“	“	28	D 14
Comm Bus 8 CH F-	“	“	28	C 14
Comm Bus 8 CH G+	“	“	28	C 15
Comm Bus 8 CH G-	“	“	28	D 15
Comm Bus 8 CH H+	“	“	28	D 16
Comm Bus 8 CH H-	“	“	28	C 16

**Table A.20—IEEE 1149.1 bus**

CTI name	Legacy system	Recommended attributes	Slot	Pin
JTAG 1149.1_tck (Test Clock Output) (See NOTE)	LM-STAR	IEEE 1149.1 specification	3	C 44
JTAG 1149_shd	LM-STAR	IEEE 1149.1 specification	3	C 45
JTAG 1149.1_tdi (Test Data Input)	LM-STAR	IEEE 1149.1 specification	3	C 46
JTAG 1149_shd	LM-STAR	IEEE 1149.1 specification	3	C 47
JTAG 1149.1_tdo (Test Data Output)	LM-STAR	IEEE 1149.1 specification	3	C 48
JTAG 1149_shd	LM-STAR	IEEE 1149.1 specification	3	C 49
JTAG 1149.1_tms (Test Mode Select Output) (See NOTE)	LM-STAR	IEEE 1149.1 specification	3	D 44
JTAG 1149_shd	LM-STAR	IEEE 1149.1 specification	3	D 45
JTAG 1149.1_trst (Test Reset Output)	LM-STAR	IEEE 1149.1 specification	3	D 46
JTAG 1149_shd	LM-STAR	IEEE 1149.1 specification	3	D 47
JTAG mux_en (Scan Multiplex Enable)	LM-STAR	Contractor specific	3	D 48
JTAG pdi_1 (Programmable Digital Input 1)	LM-STAR	Contractor specific	28	B38
JTAG pdi_2	LM-STAR	Contractor specific	28	A39
JTAG pdi_3	LM-STAR	Contractor specific	28	B40
JTAG pdo_1 (Programmable Digital Output 1)	LM-STAR	Contractor specific	28	A41
JTAG pdo_2	LM-STAR	Contractor specific	28	B42
JTAG pdo_3	LM-STAR	Contractor specific	28	C39
JTAG pdo_4	LM-STAR	Contractor specific	28	D40
JTAG pdo_5	LM-STAR	Contractor specific	28	C41
JTAG pdo_6	LM-STAR	Contractor specific	28	D42
JTAG pdo_7	LM-STAR	Contractor specific	28	C42
NOTE—Terminated with 100 Ω to ground, TTL Logic.				

Table A.21—Digital channels

CTI name	Legacy system	Recommended attributes	Slot	Pin
DIGITAL CH 1 (+)	IFTE, CASS, LM-STAR, ESTS, SAME, TETS, IAIS, C17, RAF	Max data rate: 50 MHz Max voltage: $\pm 30$ V Max current: 60 mA	9	A 1
DIGITAL CH 1 (-)	“	“	9	B 1
DIGITAL CH 2 (+)	“	“	9	B 2
DIGITAL CH 2 (-)	“	“	9	A 2
DIGITAL CH 3 (+)	“	“	9	A 3
DIGITAL CH 3 (-)	“	“	9	B 3
DIGITAL CH 4 (+)	“	“	9	B 4
DIGITAL CH 4 (-)	“	“	9	A 4
DIGITAL CH 5 (+)	“	“	9	A 5
DIGITAL CH 5 (-)	“	“	9	B 5
DIGITAL CH 6 (+)	“	“	9	B 6
DIGITAL CH 6 (-)	“	“	9	A 6
DIGITAL CH 7 (+)	“	“	9	A 7
DIGITAL CH 7 (-)	“	“	9	B 7
DIGITAL CH 8 (+)	“	“	9	B 8
DIGITAL CH 8 (-)	“	“	9	A 8
DIGITAL CH 9 (+)	“	“	9	A 9
DIGITAL CH 9 (-)	“	“	9	B 9
DIGITAL CH 10 (+)	“	“	9	B 10
DIGITAL CH 10 (-)	“	“	9	A 10
DIGITAL CH 11 (+)	“	“	9	A 11
DIGITAL CH 11 (-)	“	“	9	B 11
DIGITAL CH 12 (+)	“	“	9	B 12
DIGITAL CH 12 (-)	“	“	9	A 12
DIGITAL CH 13 (+)	“	“	9	A 13
DIGITAL CH 13 (-)	“	“	9	B 13
DIGITAL CH 14 (+)	“	“	9	B 14
DIGITAL CH 14 (-)	“	“	9	A 14
DIGITAL CH 15 (+)	“	“	9	A 15
DIGITAL CH 15 (-)	“	“	9	B 15
DIGITAL CH 16 (+)	“	“	9	B 16
DIGITAL CH 16 (-)	“	“	9	A 16
DIGITAL CH 17 (+)	“	“	9	A 17
DIGITAL CH 17 (-)	“	“	9	B 17
DIGITAL CH 18 (+)	“	“	9	B 18
DIGITAL CH 18 (-)	“	“	9	A 18
DIGITAL CH 19 (+)	“	“	9	A 19
DIGITAL CH 19 (-)	“	“	9	B 19
DIGITAL CH 20 (+)	“	“	9	B 20
DIGITAL CH 20 (-)	“	“	9	A 20
DIGITAL CH 21 (+)	“	“	9	A 21
DIGITAL CH 21 (-)	“	“	9	B 21
DIGITAL CH 22 (+)	“	“	9	B 22
DIGITAL CH 22 (-)	“	“	9	A 22
DIGITAL CH 23 (+)	“	“	9	A 23
DIGITAL CH 23 (-)	“	“	9	B 23
DIGITAL CH 24 (+)	“	“	9	B 24
DIGITAL CH 24 (-)	“	“	9	A 24
DIGITAL CH 25 (+)	“	“	9	A 25

**Table A.21—Digital channels (continued)**

CTI name	Legacy system	Recommended attributes	Slot	Pin
DIGITAL CH 25 (-)	“	“	9	B 25
DIGITAL CH 26 (+)	“	“	9	B 26
DIGITAL CH 26 (-)	“	“	9	A 26
DIGITAL CH 27 (+)	“	“	9	A 27
DIGITAL CH 27 (-)	“	“	9	B 27
DIGITAL CH 28 (+)	“	“	9	B 28
DIGITAL CH 28 (-)	“	“	9	A 28
DIGITAL CH 29 (+)	“	“	9	A 29
DIGITAL CH 29 (-)	“	“	9	B 29
DIGITAL CH 30 (+)	“	“	9	B 30
DIGITAL CH 30 (-)	“	“	9	A 30
DIGITAL CH 31 (+)	“	“	9	A 31
DIGITAL CH 31 (-)	“	“	9	B 31
DIGITAL CH 32 (+)	“	“	9	B 32
DIGITAL CH 32 (-)	“	“	9	A 32
DIGITAL CH 33 (+)	“	“	9	C 1
DIGITAL CH 33 (-)	“	“	9	D 1
DIGITAL CH 34 (+)	“	“	9	D 2
DIGITAL CH 34 (-)	“	“	9	C 2
DIGITAL CH 35 (+)	“	“	9	C 3
DIGITAL CH 35 (-)	“	“	9	D 3
DIGITAL CH 36 (+)	“	“	9	D 4
DIGITAL CH 36 (-)	“	“	9	C 4
DIGITAL CH 37 (+)	“	“	9	C 5
DIGITAL CH 37 (-)	“	“	9	D 5
DIGITAL CH 38 (+)	“	“	9	D 6
DIGITAL CH 38 (-)	“	“	9	C 6
DIGITAL CH 39 (+)	“	“	9	C 7
DIGITAL CH 39 (-)	“	“	9	D 7
DIGITAL CH 40 (+)	“	“	9	D 8
DIGITAL CH 40 (-)	“	“	9	C 8
DIGITAL CH 41 (+)	“	“	9	C 9
DIGITAL CH 41 (-)	“	“	9	D 9
DIGITAL CH 42 (+)	“	“	9	D 10
DIGITAL CH 42 (-)	“	“	9	C 10
DIGITAL CH 43 (+)	“	“	9	C 11
DIGITAL CH 43 (-)	“	“	9	D 11
DIGITAL CH 44 (+)	“	“	9	D 12
DIGITAL CH 44 (-)	“	“	9	C 12
DIGITAL CH 45 (+)	“	“	9	C 13
DIGITAL CH 45 (-)	“	“	9	D 13
DIGITAL CH 46 (+)	“	“	9	D 14
DIGITAL CH 46 (-)	“	“	9	C 14
DIGITAL CH 47 (+)	“	“	9	C 15
DIGITAL CH 47 (-)	“	“	9	D 15
DIGITAL CH 48 (+)	“	“	9	D 16
DIGITAL CH 48 (-)	“	“	9	C 16
DIGITAL CH 49 (+)	“	“	9	C 17
DIGITAL CH 49 (-)	“	“	9	D 17
DIGITAL CH 50 (+)	“	“	9	D 18
DIGITAL CH 50 (-)	“	“	9	C 18
DIGITAL CH 51 (+)	“	“	9	C 19
DIGITAL CH 51 (-)	“	“	9	D 19

Table A.21—Digital channels (continued)

CTI name	Legacy system	Recommended attributes	Slot	Pin
DIGITAL CH 52 (+)	“	“	9	D 20
DIGITAL CH 52 (–)	“	“	9	C 20
DIGITAL CH 53 (+)	“	“	9	C 21
DIGITAL CH 53 (–)	“	“	9	D 21
DIGITAL CH 54 (+)	“	“	9	D 22
DIGITAL CH 54 (–)	“	“	9	C 22
DIGITAL CH 55 (+)	“	“	9	C 23
DIGITAL CH 55 (–)	“	“	9	D 23
DIGITAL CH 56 (+)	“	“	9	D 24
DIGITAL CH 56 (–)	“	“	9	C 24
DIGITAL CH 57 (+)	“	“	9	C 25
DIGITAL CH 57 (–)	“	“	9	D 25
DIGITAL CH 58 (+)	“	“	9	D 26
DIGITAL CH 58 (–)	“	“	9	C 26
DIGITAL CH 59 (+)	“	“	9	C 27
DIGITAL CH 59 (–)	“	“	9	D 27
DIGITAL CH 60 (+)	“	“	9	D 28
DIGITAL CH 60 (–)	“	“	9	C 28
DIGITAL CH 61 (+)	“	“	9	C 29
DIGITAL CH 61 (–)	“	“	9	D 29
DIGITAL CH 62 (+)	“	“	9	D 30
DIGITAL CH 62 (–)	“	“	9	C 30
DIGITAL CH 63 (+)	“	“	9	C 31
DIGITAL CH 63 (–)	“	“	9	D 31
DIGITAL CH 64 (+)	“	“	9	D 32
DIGITAL CH 64 (–)	“	“	9	C 32
Kelvin ground 1			9	A 33
Kelvin ground 1 Shield			9	B 33
DIGITAL CH 65 (+)	IFTE, CASS, LM-STAR, ESTS, SAMe, TETS, IAIS, C17, RAF	“	11	A 1
DIGITAL CH 65 (–)	“	“	11	B 1
DIGITAL CH 66 (+)	“	“	11	B 2
DIGITAL CH 66 (–)	“	“	11	A 2
DIGITAL CH 67 (+)	“	“	11	A 3
DIGITAL CH 67 (–)	“	“	11	B 3
DIGITAL CH 68 (+)	“	“	11	B 4
DIGITAL CH 68 (–)	“	“	11	A 4
DIGITAL CH 69 (+)	“	“	11	A 5
DIGITAL CH 69 (–)	“	“	11	B 5
DIGITAL CH 70 (+)	“	“	11	B 6
DIGITAL CH 70 (–)	“	“	11	A 6
DIGITAL CH 71 (+)	“	“	11	A 7
DIGITAL CH 71 (–)	“	“	11	B 7
DIGITAL CH 72 (+)	“	“	11	B 8
DIGITAL CH 72 (–)	“	“	11	A 8
DIGITAL CH 73 (+)	“	“	11	A 9
DIGITAL CH 73 (–)	“	“	11	B 9
DIGITAL CH 74 (+)	“	“	11	B 10
DIGITAL CH 74 (–)	“	“	11	A 10
DIGITAL CH 75 (+)	“	“	11	A 11
DIGITAL CH 75 (–)	“	“	11	B 11
DIGITAL CH 76 (+)	“	“	11	B 12

**Table A.21—Digital channels (continued)**

CTI name	Legacy system	Recommended attributes	Slot	Pin
DIGITAL CH 76 (-)	“	“	11	A 12
DIGITAL CH 77 (+)	“	“	11	A 13
DIGITAL CH 77 (-)	“	“	11	B 13
DIGITAL CH 78 (+)	“	“	11	B 14
DIGITAL CH 78 (-)	“	“	11	A 14
DIGITAL CH 79 (+)	“	“	11	A 15
DIGITAL CH 79 (-)	“	“	11	B 15
DIGITAL CH 80 (+)	“	“	11	B 16
DIGITAL CH 80 (-)	“	“	11	A 16
DIGITAL CH 81 (+)	“	“	11	A 17
DIGITAL CH 81 (-)	“	“	11	B 17
DIGITAL CH 82 (+)	“	“	11	B 18
DIGITAL CH 82 (-)	“	“	11	A 18
DIGITAL CH 83 (+)	“	“	11	A 19
DIGITAL CH 83 (-)	“	“	11	B 19
DIGITAL CH 84 (+)	“	“	11	B 20
DIGITAL CH 84 (-)	“	“	11	A 20
DIGITAL CH 85 (+)	“	“	11	A 21
DIGITAL CH 85 (-)	“	“	11	B 21
DIGITAL CH 86 (+)	“	“	11	B 22
DIGITAL CH 86 (-)	“	“	11	A 22
DIGITAL CH 87 (+)	“	“	11	A 23
DIGITAL CH 87 (-)	“	“	11	B 23
DIGITAL CH 88 (+)	“	“	11	B 24
DIGITAL CH 88 (-)	“	“	11	A 24
DIGITAL CH 89 (+)	“	“	11	A 25
DIGITAL CH 89 (-)	“	“	11	B 25
DIGITAL CH 90 (+)	“	“	11	B 26
DIGITAL CH 90 (-)	“	“	11	A 26
DIGITAL CH 91 (+)	“	“	11	A 27
DIGITAL CH 91 (-)	“	“	11	B 27
DIGITAL CH 92 (+)	“	“	11	B 28
DIGITAL CH 92 (-)	“	“	11	A 28
DIGITAL CH 93 (+)	“	“	11	A 29
DIGITAL CH 93 (-)	“	“	11	B 29
DIGITAL CH 94 (+)	“	“	11	B 30
DIGITAL CH 94 (-)	“	“	11	A 30
DIGITAL CH 95 (+)	“	“	11	A 31
DIGITAL CH 95 (-)	“	“	11	B 31
DIGITAL CH 96 (+)	“	“	11	B 32
DIGITAL CH 96 (-)	“	“	11	A 32

Table A.21—Digital channels (continued)

CTI name	Legacy system	Recommended attributes	Slot	Pin
DIGITAL CH 97 (+)	IFTE, CASS, LM-STAR, ESTS, SAME, TETS, IAIS, C17, RAF	“	11	A 33
DIGITAL CH 97 (–)	“	“	11	B 33
DIGITAL CH 98 (+)	“	“	11	B 34
DIGITAL CH 98 (–)	“	“	11	A 34
DIGITAL CH 99 (+)	“	“	11	A 35
DIGITAL CH 99 (–)	“	“	11	B 35
DIGITAL CH 100 (+)	“	“	11	B 36
DIGITAL CH 100 (–)	“	“	11	A 36
DIGITAL CH 101 (+)	“	“	11	A 37
DIGITAL CH 101 (–)	“	“	11	B 37
DIGITAL CH 102 (+)	“	“	11	B 38
DIGITAL CH 102 (–)	“	“	11	A 38
DIGITAL CH 103 (+)	“	“	11	A 39
DIGITAL CH 103 (–)	“	“	11	B 39
DIGITAL CH 104 (+)	“	“	11	B 40
DIGITAL CH 104 (–)	“	“	11	A 40
DIGITAL CH 105 (+)	“	“	11	A 41
DIGITAL CH 105 (–)	“	“	11	B 41
DIGITAL CH 106 (+)	“	“	11	B 42
DIGITAL CH 106 (–)	“	“	11	A 42
DIGITAL CH 107 (+)	“	“	11	A 43
DIGITAL CH 107 (–)	“	“	11	B 43
DIGITAL CH 108 (+)	“	“	11	B 44
DIGITAL CH 108 (–)	“	“	11	A 44
DIGITAL CH 109 (+)	“	“	11	A 45
DIGITAL CH 109 (–)	“	“	11	B 45
DIGITAL CH 110 (+)	“	“	11	B 46
DIGITAL CH 110 (–)	“	“	11	A 46
DIGITAL CH 111 (+)	“	“	11	A 47
DIGITAL CH 111 (–)	“	“	11	B 47
DIGITAL CH 112 (+)	“	“	11	B 48
DIGITAL CH 112 (–)	“	“	11	A 48
DIGITAL CH 113 (+)	“	“	11	C 1
DIGITAL CH 113 (–)	“	“	11	D 1
DIGITAL CH 114 (+)	“	“	11	D 2
DIGITAL CH 114 (–)	“	“	11	C 2
DIGITAL CH 115 (+)	“	“	11	C 3
DIGITAL CH 115 (–)	“	“	11	D 3
DIGITAL CH 116 (+)	“	“	11	D 4
DIGITAL CH 116 (–)	“	“	11	C 4
DIGITAL CH 117 (+)	“	“	11	C 5
DIGITAL CH 117 (–)	“	“	11	D 5
DIGITAL CH 118 (+)	“	“	11	D 6
DIGITAL CH 118 (–)	“	“	11	C 6
DIGITAL CH 119 (+)	“	“	11	C 7
DIGITAL CH 119 (–)	“	“	11	D 7
DIGITAL CH 120 (+)	“	“	11	D 8
DIGITAL CH 120 (–)	“	“	11	C 8
DIGITAL CH 121 (+)	“	“	11	C 9

**Table A.21—Digital channels (continued)**

CTI name	Legacy system	Recommended attributes	Slot	Pin
DIGITAL CH 121 (-)	“	“	11	D 9
DIGITAL CH 122 (+)	“	“	11	D 10
DIGITAL CH 122 (-)	“	“	11	C 10
DIGITAL CH 123 (+)	“	“	11	C 11
DIGITAL CH 123 (-)	“	“	11	D 11
DIGITAL CH 124 (+)	“	“	11	D 12
DIGITAL CH 124 (-)	“	“	11	C 12
DIGITAL CH 125 (+)	“	“	11	C 13
DIGITAL CH 125 (-)	“	“	11	D 13
DIGITAL CH 126 (+)	“	“	11	D 14
DIGITAL CH 126 (-)	“	“	11	C 14
DIGITAL CH 127 (+)	“	“	11	C 15
DIGITAL CH 127 (-)	“	“	11	D 15
DIGITAL CH 128 (+)	“	“	11	D 16
DIGITAL CH 128 (-)	“	“	11	C 16
DIGITAL CH 129 (+)	IFTE, CASS, LM-STAR, ESTS, TETS, IAIS, C17, RAF	“	11	C 17
DIGITAL CH 129 (-)	“	“	11	D 17
DIGITAL CH 130 (+)	“	“	11	D 18
DIGITAL CH 130 (-)	“	“	11	C 18
DIGITAL CH 131 (+)	“	“	11	C 19
DIGITAL CH 131 (-)	“	“	11	D 19
DIGITAL CH 132 (+)	“	“	11	D 20
DIGITAL CH 132 (-)	“	“	11	C 20
DIGITAL CH 133 (+)	“	“	11	C 21
DIGITAL CH 133 (-)	“	“	11	D 21
DIGITAL CH 134 (+)	“	“	11	D 22
DIGITAL CH 134 (-)	“	“	11	C 22
DIGITAL CH 135 (+)	“	“	11	C 23
DIGITAL CH 135 (-)	“	“	11	D 23
DIGITAL CH 136 (+)	“	“	11	D 24
DIGITAL CH 136 (-)	“	“	11	C 24
DIGITAL CH 137 (+)	“	“	11	C 25
DIGITAL CH 137 (-)	“	“	11	D 25
DIGITAL CH 138 (+)	“	“	11	D 26
DIGITAL CH 138 (-)	“	“	11	C 26
DIGITAL CH 139 (+)	“	“	11	C 27
DIGITAL CH 139 (-)	“	“	11	D 27
DIGITAL CH 140 (+)	“	“	11	D 28
DIGITAL CH 140 (-)	“	“	11	C 28
DIGITAL CH 141 (+)	“	“	11	C 29
DIGITAL CH 141 (-)	“	“	11	D 29
DIGITAL CH 142 (+)	“	“	11	D 30
DIGITAL CH 142 (-)	“	“	11	C 30
DIGITAL CH 143 (+)	“	“	11	C 31
DIGITAL CH 143 (-)	“	“	11	D 31
DIGITAL CH 144 (+)	“	“	11	D 32
DIGITAL CH 144 (-)	“	“	11	C 32
DIGITAL CH 145 (+)	“	“	11	C 33
DIGITAL CH 145 (-)	“	“	11	D 33
DIGITAL CH 146 (+)	“	“	11	D 34



Table A.21—Digital channels (*continued*)

CTI name	Legacy system	Recommended attributes	Slot	Pin
DIGITAL CH 146 (-)	“	“	11	C 34
DIGITAL CH 147 (+)	“	“	11	C 35
DIGITAL CH 147 (-)	“	“	11	D 35
DIGITAL CH 148 (+)	“	“	11	D 36
DIGITAL CH 148 (-)	“	“	11	C 36
DIGITAL CH 149 (+)	“	“	11	C 37
DIGITAL CH 149 (-)	“	“	11	D 37
DIGITAL CH 150 (+)	“	“	11	D 38
DIGITAL CH 150 (-)	“	“	11	C 38
DIGITAL CH 151 (+)	“	“	11	C 39
DIGITAL CH 151 (-)	“	“	11	D 39
DIGITAL CH 152 (+)	“	“	11	D 40
DIGITAL CH 152 (-)	“	“	11	C 40
DIGITAL CH 153 (+)	“	“	11	C 41
DIGITAL CH 153 (-)	“	“	11	D 41
DIGITAL CH 154 (+)	“	“	11	D 42
DIGITAL CH 154 (-)	“	“	11	C 42
DIGITAL CH 155 (+)	“	“	11	C 43
DIGITAL CH 155 (-)	“	“	11	D 43
DIGITAL CH 156 (+)	“	“	11	D 44
DIGITAL CH 156 (-)	“	“	11	C 44
DIGITAL CH 157 (+)	“	“	11	C 45
DIGITAL CH 157 (-)	“	“	11	D 45
DIGITAL CH 158 (+)	“	“	11	D 46
DIGITAL CH 158 (-)	“	“	11	C 46
DIGITAL CH 159 (+)	“	“	11	C 47
DIGITAL CH 159 (-)	“	“	11	D 47
DIGITAL CH 160 (+)	“	“	11	D 48
DIGITAL CH 160 (-)	“	“	11	C 48
Kelvin ground 2			11	A 49
Kelvin ground 2 Shield			11	B 49
DIGITAL CH 161 (+)	IFTE, CASS, LM-STAR, ESTS, TETS, IAIS, C17, RAF	“	12	A 1
DIGITAL CH 161 (-)	“	“	12	B 1
DIGITAL CH 162 (+)	“	“	12	B 2
DIGITAL CH 162 (-)	“	“	12	A 2
DIGITAL CH 163 (+)	“	“	12	A 3
DIGITAL CH 163 (-)	“	“	12	B 3
DIGITAL CH 164 (+)	“	“	12	B 4
DIGITAL CH 164 (-)	“	“	12	A 4
DIGITAL CH 165 (+)	“	“	12	A 5
DIGITAL CH 165 (-)	“	“	12	B 5
DIGITAL CH 166 (+)	“	“	12	B 6
DIGITAL CH 166 (-)	“	“	12	A 6
DIGITAL CH 167 (+)	“	“	12	A 7
DIGITAL CH 167 (-)	“	“	12	B 7
DIGITAL CH 168 (+)	“	“	12	B 8
DIGITAL CH 168 (-)	“	“	12	A 8
DIGITAL CH 169 (+)	“	“	12	A 9
DIGITAL CH 169 (-)	“	“	12	B 9

**Table A.21—Digital channels (continued)**

CTI name	Legacy system	Recommended attributes	Slot	Pin
DIGITAL CH 170 (+)	“	“	12	B 10
DIGITAL CH 170 (-)	“	“	12	A 10
DIGITAL CH 171 (+)	“	“	12	A 11
DIGITAL CH 171 (-)	“	“	12	B 11
DIGITAL CH 172 (+)	“	“	12	B 12
DIGITAL CH 172 (-)	“	“	12	A 12
DIGITAL CH 173 (+)	“	“	12	A 13
DIGITAL CH 173 (-)	“	“	12	B 13
DIGITAL CH 174 (+)	“	“	12	B 14
DIGITAL CH 174 (-)	“	“	12	A 14
DIGITAL CH 175 (+)	“	“	12	A 15
DIGITAL CH 175 (-)	“	“	12	B 15
DIGITAL CH 176 (+)	“	“	12	B 16
DIGITAL CH 176 (-)	“	“	12	A 16
DIGITAL CH 177 (+)	“	“	12	A 17
DIGITAL CH 177 (-)	“	“	12	B 17
DIGITAL CH 178 (+)	“	“	12	B 18
DIGITAL CH 178 (-)	“	“	12	A 18
DIGITAL CH 179 (+)	“	“	12	A 19
DIGITAL CH 179 (-)	“	“	12	B 19
DIGITAL CH 180 (+)	“	“	12	B 20
DIGITAL CH 180 (-)	“	“	12	A 20
DIGITAL CH 181 (+)	“	“	12	A 21
DIGITAL CH 181 (-)	“	“	12	B 21
DIGITAL CH 182 (+)	“	“	12	B 22
DIGITAL CH 182 (-)	“	“	12	A 22
DIGITAL CH 183 (+)	“	“	12	A 23
DIGITAL CH 183 (-)	“	“	12	B 23
DIGITAL CH 184 (+)	“	“	12	B 24
DIGITAL CH 184 (-)	“	“	12	A 24
DIGITAL CH 185 (+)	“	“	12	A 25
DIGITAL CH 185 (-)	“	“	12	B 25
DIGITAL CH 186 (+)	“	“	12	B 26
DIGITAL CH 186 (-)	“	“	12	A 26
DIGITAL CH 187 (+)	“	“	12	A 27
DIGITAL CH 187 (-)	“	“	12	B 27
DIGITAL CH 188 (+)	“	“	12	B 28
DIGITAL CH 188 (-)	“	“	12	A 28
DIGITAL CH 189 (+)	“	“	12	A 29
DIGITAL CH 189 (-)	“	“	12	B 29
DIGITAL CH 190 (+)	“	“	12	B 30
DIGITAL CH 190 (-)	“	“	12	A 30
DIGITAL CH 191 (+)	“	“	12	A 31
DIGITAL CH 191 (-)	“	“	12	B 31
DIGITAL CH 192 (+)	“	“	12	B 32
DIGITAL CH 192 (-)	“	“	12	A 32

Table A.21—Digital channels (*continued*)

CTI name	Legacy system	Recommended attributes	Slot	Pin
DIGITAL CH 193 (+)	IFTE, CASS, LM-STAR, ESTS, SAME, IAIS, C17, RAF	“	12	A 33
DIGITAL CH 193 (–)	“	“	12	B 33
DIGITAL CH 194 (+)	“	“	12	B 34
DIGITAL CH 194 (–)	“	“	12	A 34
DIGITAL CH 195 (+)	“	“	12	A 35
DIGITAL CH 195 (–)	“	“	12	B 35
DIGITAL CH 196 (+)	“	“	12	B 36
DIGITAL CH 196 (–)	“	“	12	A 36
DIGITAL CH 197 (+)	“	“	12	A 37
DIGITAL CH 197 (–)	“	“	12	B 37
DIGITAL CH 198 (+)	“	“	12	B 38
DIGITAL CH 198 (–)	“	“	12	A 38
DIGITAL CH 199 (+)	“	“	12	A 39
DIGITAL CH 199 (–)	“	“	12	B 39
DIGITAL CH 200 (+)	“	“	12	B 40
DIGITAL CH 200 (–)	“	“	12	A 40
DIGITAL CH 201 (+)	“	“	12	A 41
DIGITAL CH 201 (–)	“	“	12	B 41
DIGITAL CH 202 (+)	“	“	12	B 42
DIGITAL CH 202 (–)	“	“	12	A 42
DIGITAL CH 203 (+)	“	“	12	A 43
DIGITAL CH 203 (–)	“	“	12	B 43
DIGITAL CH 204 (+)	“	“	12	B 44
DIGITAL CH 204 (–)	“	“	12	A 44
DIGITAL CH 205 (+)	“	“	12	A 45
DIGITAL CH 205 (–)	“	“	12	B 45
DIGITAL CH 206 (+)	“	“	12	B 46
DIGITAL CH 206 (–)	“	“	12	A 46
DIGITAL CH 207 (+)	“	“	12	A 47
DIGITAL CH 207 (–)	“	“	12	B 47
DIGITAL CH 208 (+)	“	“	12	B 48
DIGITAL CH 208 (–)	“	“	12	A 48
DIGITAL CH 209 (+)	“	“	12	C 1
DIGITAL CH 209 (–)	“	“	12	D 1
DIGITAL CH 210 (+)	“	“	12	D 2
DIGITAL CH 210 (–)	“	“	12	C 2
DIGITAL CH 211 (+)	“	“	12	C 3
DIGITAL CH 211 (–)	“	“	12	D 3
DIGITAL CH 212 (+)	“	“	12	D 4
DIGITAL CH 212 (–)	“	“	12	C 4
DIGITAL CH 213 (+)	“	“	12	C 5
DIGITAL CH 213 (–)	“	“	12	D 5
DIGITAL CH 214 (+)	“	“	12	D 6
DIGITAL CH 214 (–)	“	“	12	C 6
DIGITAL CH 215 (+)	“	“	12	C 7
DIGITAL CH 215 (–)	“	“	12	D 7
DIGITAL CH 216 (+)	“	“	12	D 8
DIGITAL CH 216 (–)	“	“	12	C 8
DIGITAL CH 217 (+)	“	“	12	C 9

**Table A.21—Digital channels (continued)**

CTI name	Legacy system	Recommended attributes	Slot	Pin
DIGITAL CH 217 (-)	“	“	12	D 9
DIGITAL CH 218 (+)	“	“	12	D 10
DIGITAL CH 218 (-)	“	“	12	C 10
DIGITAL CH 219 (+)	“	“	12	C 11
DIGITAL CH 219 (-)	“	“	12	D 11
DIGITAL CH 220 (+)	“	“	12	D 12
DIGITAL CH 220 (-)	“	“	12	C 12
DIGITAL CH 221 (+)	“	“	12	C 13
DIGITAL CH 221 (-)	“	“	12	D 13
DIGITAL CH 222 (+)	“	“	12	D 14
DIGITAL CH 222 (-)	“	“	12	C 14
DIGITAL CH 223 (+)	“	“	12	C 15
DIGITAL CH 223 (-)	“	“	12	D 15
DIGITAL CH 224 (+)	“	“	12	D 16
DIGITAL CH 224 (-)	“	“	12	C 16
DIGITAL CH 225 (+)	IFTE, CASS, LM-STAR, ESTS, SAME, IAIS, C17, RAF	“	12	C 17
DIGITAL CH 225 (-)	“	“	12	D 17
DIGITAL CH 226 (+)	“	“	12	D 18
DIGITAL CH 226 (-)	“	“	12	C 18
DIGITAL CH 227 (+)	“	“	12	C 19
DIGITAL CH 227 (-)	“	“	12	D 19
DIGITAL CH 228 (+)	“	“	12	D 20
DIGITAL CH 228 (-)	“	“	12	C 20
DIGITAL CH 229 (+)	“	“	12	C 21
DIGITAL CH 229 (-)	“	“	12	D 21
DIGITAL CH 230 (+)	“	“	12	D 22
DIGITAL CH 230 (-)	“	“	12	C 22
DIGITAL CH 231 (+)	“	“	12	C 23
DIGITAL CH 231 (-)	“	“	12	D 23
DIGITAL CH 232 (+)	“	“	12	D 24
DIGITAL CH 232 (-)	“	“	12	C 24
DIGITAL CH 233 (+)	“	“	12	C 25
DIGITAL CH 233 (-)	“	“	12	D 25
DIGITAL CH 234 (+)	“	“	12	D 26
DIGITAL CH 234 (-)	“	“	12	C 26
DIGITAL CH 235 (+)	“	“	12	C 27
DIGITAL CH 235 (-)	“	“	12	D 27
DIGITAL CH 236 (+)	“	“	12	D 28
DIGITAL CH 236 (-)	“	“	12	C 28
DIGITAL CH 237 (+)	“	“	12	C 29
DIGITAL CH 237 (-)	“	“	12	D 29
DIGITAL CH 238 (+)	“	“	12	D 30
DIGITAL CH 238 (-)	“	“	12	C 30
DIGITAL CH 239 (+)	“	“	12	C 31
DIGITAL CH 239 (-)	“	“	12	D 31
DIGITAL CH 240 (+)	“	“	12	D 32
DIGITAL CH 240 (-)	“	“	12	C 32
DIGITAL CH 241 (+)	“	“	12	C 33
DIGITAL CH 241 (-)	“	“	12	D 33
DIGITAL CH 242 (+)	“	“	12	D 34

Table A.21—Digital channels (*continued*)

CTI name	Legacy system	Recommended attributes	Slot	Pin
DIGITAL CH 242 (-)	“	“	12	C 34
DIGITAL CH 243 (+)	“	“	12	C 35
DIGITAL CH 243 (-)	“	“	12	D 35
DIGITAL CH 244 (+)	“	“	12	D 36
DIGITAL CH 244 (-)	“	“	12	C 36
DIGITAL CH 245 (+)	“	“	12	C 37
DIGITAL CH 245 (-)	“	“	12	D 37
DIGITAL CH 246 (+)	“	“	12	D 38
DIGITAL CH 246 (-)	“	“	12	C 38
DIGITAL CH 247 (+)	“	“	12	C 39
DIGITAL CH 247 (-)	“	“	12	D 39
DIGITAL CH 248 (+)	“	“	12	D 40
DIGITAL CH 248 (-)	“	“	12	C 40
DIGITAL CH 249 (+)	“	“	12	C 41
DIGITAL CH 249 (-)	“	“	12	D 41
DIGITAL CH 250 (+)	“	“	12	D 42
DIGITAL CH 250 (-)	“	“	12	C 42
DIGITAL CH 251 (+)	“	“	12	C 43
DIGITAL CH 251 (-)	“	“	12	D 43
DIGITAL CH 252 (+)	“	“	12	D 44
DIGITAL CH 252 (-)	“	“	12	C 44
DIGITAL CH 253 (+)	“	“	12	C 45
DIGITAL CH 253 (-)	“	“	12	D 45
DIGITAL CH 254 (+)	“	“	12	D 46
DIGITAL CH 254 (-)	“	“	12	C 46
DIGITAL CH 255 (+)	“	“	12	C 47
DIGITAL CH 255 (-)	“	“	12	D 47
DIGITAL CH 256 (+)	“	“	12	D 48
DIGITAL CH 256 (-)	“	“	12	C 48
Kelvin ground 3	“	“	12	A 49
Kelvin ground 3 Shield	“	“	12	B 49
DIGITAL CH 257 (+)	IFTE, CASS, LM-STAR, ESTS, IAIS, C17, RAF	“	13	A 1
DIGITAL CH 257 (-)	“	“	13	B 1
DIGITAL CH 258 (+)	“	“	13	B 2
DIGITAL CH 258 (-)	“	“	13	A 2
DIGITAL CH 259 (+)	“	“	13	A 3
DIGITAL CH 259 (-)	“	“	13	B 3
DIGITAL CH 260 (+)	“	“	13	B 4
DIGITAL CH 260 (-)	“	“	13	A 4
DIGITAL CH 261 (+)	“	“	13	A 5
DIGITAL CH 261 (-)	“	“	13	B 5
DIGITAL CH 262 (+)	“	“	13	B 6
DIGITAL CH 262 (-)	“	“	13	A 6
DIGITAL CH 263 (+)	“	“	13	A 7
DIGITAL CH 263 (-)	“	“	13	B 7
DIGITAL CH 264 (+)	“	“	13	B 8
DIGITAL CH 264 (-)	“	“	13	A 8

**Table A.21—Digital channels (continued)**

CTI name	Legacy system	Recommended attributes	Slot	Pin
DIGITAL CH 265 (+)	“	“	13	A 9
DIGITAL CH 265 (-)	“	“	13	B 9
DIGITAL CH 266 (+)	“	“	13	B 10
DIGITAL CH 266 (-)	“	“	13	A 10
DIGITAL CH 267 (+)	“	“	13	A 11
DIGITAL CH 267 (-)	“	“	13	B 11
DIGITAL CH 268 (+)	“	“	13	B 12
DIGITAL CH 268 (-)	“	“	13	A 12
DIGITAL CH 269 (+)	“	“	13	A 13
DIGITAL CH 269 (-)	“	“	13	B 13
DIGITAL CH 270 (+)	“	“	13	B 14
DIGITAL CH 270 (-)	“	“	13	A 14
DIGITAL CH 271 (+)	“	“	13	A 15
DIGITAL CH 271 (-)	“	“	13	B 15
DIGITAL CH 272 (+)	“	“	13	B 16
DIGITAL CH 272 (-)	“	“	13	A 16
DIGITAL CH 273 (+)	“	“	13	A 17
DIGITAL CH 273 (-)	“	“	13	B 17
DIGITAL CH 274 (+)	“	“	13	B 18
DIGITAL CH 274 (-)	“	“	13	A 18
DIGITAL CH 275 (+)	“	“	13	A 19
DIGITAL CH 275 (-)	“	“	13	B 19
DIGITAL CH 276 (+)	“	“	13	B 20
DIGITAL CH 276 (-)	“	“	13	A 20
DIGITAL CH 277 (+)	“	“	13	A 21
DIGITAL CH 277 (-)	“	“	13	B 21
DIGITAL CH 278 (+)	“	“	13	B 22
DIGITAL CH 278 (-)	“	“	13	A 22
DIGITAL CH 279 (+)	“	“	13	A 23
DIGITAL CH 279 (-)	“	“	13	B 23
DIGITAL CH 280 (+)	“	“	13	B 24
DIGITAL CH 280 (-)	“	“	13	A 24
DIGITAL CH 281 (+)	“	“	13	A 25
DIGITAL CH 281 (-)	“	“	13	B 25
DIGITAL CH 282 (+)	“	“	13	B 26
DIGITAL CH 282 (-)	“	“	13	A 26
DIGITAL CH 283 (+)	“	“	13	A 27
DIGITAL CH 283 (-)	“	“	13	B 27
DIGITAL CH 284 (+)	“	“	13	B 28
DIGITAL CH 284 (-)	“	“	13	A 28
DIGITAL CH 285 (+)	“	“	13	A 29
DIGITAL CH 285 (-)	“	“	13	B 29
DIGITAL CH 286 (+)	“	“	13	B 30
DIGITAL CH 286 (-)	“	“	13	A 30
DIGITAL CH 287 (+)	“	“	13	A 31
DIGITAL CH 287 (-)	“	“	13	B 31
DIGITAL CH 288 (+)	“	“	13	B 32
DIGITAL CH 288 (-)	“	“	13	A 32

Table A.21—Digital channels (continued)

CTI name	Legacy system	Recommended attributes	Slot	Pin
DIGITAL CH 289 (+)	IFTE, CASS, LM-STAR, SAME, ESTS, IAIS, C17, RAF	“	13	A 33
DIGITAL CH 289 (–)	“	“	13	B 33
DIGITAL CH 290 (+)	“	“	13	B 34
DIGITAL CH 290 (–)	“	“	13	A 34
DIGITAL CH 291 (+)	“	“	13	A 35
DIGITAL CH 291 (–)	“	“	13	B 35
DIGITAL CH 292 (+)	“	“	13	B 36
DIGITAL CH 292 (–)	“	“	13	A 36
DIGITAL CH 293 (+)	“	“	13	A 37
DIGITAL CH 293 (–)	“	“	13	B 37
DIGITAL CH 294 (+)	“	“	13	B 38
DIGITAL CH 294 (–)	“	“	13	A 38
DIGITAL CH 295 (+)	“	“	13	A 39
DIGITAL CH 295 (–)	“	“	13	B 39
DIGITAL CH 296 (+)	“	“	13	B 40
DIGITAL CH 296 (–)	“	“	13	A 40
DIGITAL CH 297 (+)	“	“	13	A 41
DIGITAL CH 297 (–)	“	“	13	B 41
DIGITAL CH 298 (+)	“	“	13	B 42
DIGITAL CH 298 (–)	“	“	13	A 42
DIGITAL CH 299 (+)	“	“	13	A 43
DIGITAL CH 299 (–)	“	“	13	B 43
DIGITAL CH 300 (+)	“	“	13	B 44
DIGITAL CH 300 (–)	“	“	13	A 44
DIGITAL CH 301 (+)	“	“	13	A 45
DIGITAL CH 301 (–)	“	“	13	B 45
DIGITAL CH 302 (+)	“	“	13	B 46
DIGITAL CH 302 (–)	“	“	13	A 46
DIGITAL CH 303 (+)	“	“	13	A 47
DIGITAL CH 303 (–)	“	“	13	B 47
DIGITAL CH 304 (+)	“	“	13	B 48
DIGITAL CH 304 (–)	“	“	13	A 48
DIGITAL CH 305 (+)	“	“	13	C 1
DIGITAL CH 305 (–)	“	“	13	D 1
DIGITAL CH 306 (+)	“	“	13	D 2
DIGITAL CH 306 (–)	“	“	13	C 2
DIGITAL CH 307 (+)	“	“	13	C 3
DIGITAL CH 307 (–)	“	“	13	D 3
DIGITAL CH 308 (+)	“	“	13	D 4
DIGITAL CH 308 (–)	“	“	13	C 4
DIGITAL CH 309 (+)	“	“	13	C 5
DIGITAL CH 309 (–)	“	“	13	D 5
DIGITAL CH 310 (+)	“	“	13	D 6
DIGITAL CH 310 (–)	“	“	13	C 6
DIGITAL CH 311 (+)	“	“	13	C 7
DIGITAL CH 311 (–)	“	“	13	D 7
DIGITAL CH 312 (+)	“	“	13	D 8
DIGITAL CH 312 (–)	“	“	13	C 8
DIGITAL CH 313 (+)	“	“	13	C 9
DIGITAL CH 313 (–)	“	“	13	D 9
DIGITAL CH 314 (+)	“	“	13	D 10

**Table A.21—Digital channels (continued)**

CTI name	Legacy system	Recommended attributes	Slot	Pin
DIGITAL CH 314 (-)	“	“	13	C 10
DIGITAL CH 315 (+)	“	“	13	C 11
DIGITAL CH 315 (-)	“	“	13	D 11
DIGITAL CH 316 (+)	“	“	13	D 12
DIGITAL CH 316 (-)	“	“	13	C 12
DIGITAL CH 317 (+)	“	“	13	C 13
DIGITAL CH 317 (-)	“	“	13	D 13
DIGITAL CH 318 (+)	“	“	13	D 14
DIGITAL CH 318 (-)	“	“	13	C 14
DIGITAL CH 319 (+)	“	“	13	C 15
DIGITAL CH 319 (-)	“	“	13	D 15
DIGITAL CH 320 (+)	“	“	13	D 16
DIGITAL CH 320 (-)	“	“	13	C 16
DIGITAL CH 321 (+)	IFTE, CASS, LM-STAR, SAMe, ESTS, IAIS, C17, RAF	“	13	C 17
DIGITAL CH 321 (-)	“	“	13	D 17
DIGITAL CH 322 (+)	“	“	13	D 18
DIGITAL CH 322 (-)	“	“	13	C 18
DIGITAL CH 323 (+)	“	“	13	C 19
DIGITAL CH 323 (-)	“	“	13	D 19
DIGITAL CH 324 (+)	“	“	13	D 20
DIGITAL CH 324 (-)	“	“	13	C 20
DIGITAL CH 325 (+)	“	“	13	C 21
DIGITAL CH 325 (-)	“	“	13	D 21
DIGITAL CH 326 (+)	“	“	13	D 22
DIGITAL CH 326 (-)	“	“	13	C 22
DIGITAL CH 327 (+)	“	“	13	C 23
DIGITAL CH 327 (-)	“	“	13	D 23
DIGITAL CH 328 (+)	“	“	13	D 24
DIGITAL CH 328 (-)	“	“	13	C 24
DIGITAL CH 329 (+)	“	“	13	C 25
DIGITAL CH 329 (-)	“	“	13	D 25
DIGITAL CH 330 (+)	“	“	13	D 26
DIGITAL CH 330 (-)	“	“	13	C 26
DIGITAL CH 331 (+)	“	“	13	C 27
DIGITAL CH 331 (-)	“	“	13	D 27
DIGITAL CH 332 (+)	“	“	13	D 28
DIGITAL CH 332 (-)	“	“	13	C 28
DIGITAL CH 333 (+)	“	“	13	C 29
DIGITAL CH 333 (-)	“	“	13	D 29
DIGITAL CH 334 (+)	“	“	13	D 30
DIGITAL CH 334 (-)	“	“	13	C 30
DIGITAL CH 335 (+)	“	“	13	C 31
DIGITAL CH 335 (-)	“	“	13	D 31
DIGITAL CH 336 (+)	“	“	13	D 32
DIGITAL CH 336 (-)	“	“	13	C 32
DIGITAL CH 337 (+)	CASS, LM-STAR, SAMe, ESTS, IAIS, C17, RAF	“	13	C 33
DIGITAL CH 337 (-)	“	“	13	D 33



Table A.21—Digital channels (continued)

CTI name	Legacy system	Recommended attributes	Slot	Pin
DIGITAL CH 338 (+)	IFTE, CASS, LM-STAR, SAME, ESTS, IAIS, C17, RAF	“	13	D 34
DIGITAL CH 338 (–)	“	“	13	C 34
DIGITAL CH 339 (+)	“	“	13	C 35
DIGITAL CH 339 (–)	“	“	13	D 35
DIGITAL CH 340 (+)	CASS, LM-STAR, SAME, ESTS, IAIS, C17, RAF	“	13	D 36
DIGITAL CH 340 (–)	“	“	13	C 36
DIGITAL CH 341 (+)	IFTE, CASS, LM-STAR, SAME, ESTS, IAIS, C17, RAF	“	13	C 37
DIGITAL CH 341 (–)	“	“	13	D 37
DIGITAL CH 342 (+)	“	“	13	D 38
DIGITAL CH 342 (–)	“	“	13	C 38
DIGITAL CH 343 (+)	“	“	13	C 39
DIGITAL CH 343 (–)	“	“	13	D 39
DIGITAL CH 344 (+)	“	“	13	D 40
DIGITAL CH 344 (–)	“	“	13	C 40
DIGITAL CH 345 (+)	“	“	13	C 41
DIGITAL CH 345 (–)	“	“	13	D 41
DIGITAL CH 346 (+)	“	“	13	D 42
DIGITAL CH 346 (–)	“	“	13	C 42
DIGITAL CH 347 (+)	“	“	13	C 43
DIGITAL CH 347 (–)	“	“	13	D 43
DIGITAL CH 348 (+)	“	“	13	D 44
DIGITAL CH 348 (–)	“	“	13	C 44
DIGITAL CH 349 (+)	CASS, LM-STAR, SAME, ESTS, IAIS, C17, RAF	“	13	C 45
DIGITAL CH 349 (–)	“	“	13	D 45
DIGITAL CH 350 (+)	“	“	13	D 46
DIGITAL CH 350 (–)	“	“	13	C 46
DIGITAL CH 351 (+)	“	“	13	C 47
DIGITAL CH 351 (–)	“	“	13	D 47
DIGITAL CH 352 (+)	“	“	13	D 48
DIGITAL CH 352 (–)	“	“	13	C 48
DIGITAL CH 353 (+)	IFTE, CASS, LM- STAR, SAME, ESTS, IAIS, C17, RAF	“	14	A 1
DIGITAL CH 353 (–)	“	“	14	B 1
DIGITAL CH 354 (+)	“	“	14	B 2
DIGITAL CH 354 (–)	“	“	14	A 2
DIGITAL CH 355 (+)	“	“	14	A 3
DIGITAL CH 355 (–)	“	“	14	B 3
DIGITAL CH 356 (+)	“	“	14	B 4
DIGITAL CH 356 (–)	“	“	14	A 4
DIGITAL CH 357 (+)	“	“	14	A 5
DIGITAL CH 357 (–)	“	“	14	B 5

**Table A.21—Digital channels (continued)**

CTI name	Legacy system	Recommended attributes	Slot	Pin
DIGITAL CH 358 (+)	IFTE, CASS, LM-STAR, SAME, IAIS, C17, RAF	“	14	B 6
DIGITAL CH 358 (–)	“	“	14	A 6
DIGITAL CH 359 (+)	“	“	14	A 7
DIGITAL CH 359 (–)	“	“	14	B 7
DIGITAL CH 360 (+)	“	“	14	B 8
DIGITAL CH 360 (–)	“	“	14	A 8
DIGITAL CH 361 (+)	“	“	14	A 9
DIGITAL CH 361 (–)	“	“	14	B 9
DIGITAL CH 362 (+)	“	“	14	B 10
DIGITAL CH 362 (–)	“	“	14	A 10
DIGITAL CH 363 (+)	“	“	14	A 11
DIGITAL CH 363 (–)	“	“	14	B 11
DIGITAL CH 364 (+)	“	“	14	B 12
DIGITAL CH 364 (–)	“	“	14	A 12
DIGITAL CH 365 (+)	“	“	14	A 13
DIGITAL CH 365 (–)	“	“	14	B 13
DIGITAL CH 366 (+)	“	“	14	B 14
DIGITAL CH 366 (–)	“	“	14	A 14
DIGITAL CH 367 (+)	“	“	14	A 15
DIGITAL CH 367 (–)	“	“	14	B 15
DIGITAL CH 368 (+)	“	“	14	B 16
DIGITAL CH 368 (–)	“	“	14	A 16
DIGITAL CH 369 (+)	CASS, LM-STAR, SAME, IAIS, C17	“	14	A 17
DIGITAL CH 369 (–)	“	“	14	B 17
DIGITAL CH 370 (+)	IFTE, CASS, LM-STAR, SAME, IAIS, C17	“	14	B 18
DIGITAL CH 370 (–)	“	“	14	A 18
DIGITAL CH 371 (+)	“	“	14	A 19
DIGITAL CH 371 (–)	“	“	14	B 19
DIGITAL CH 372 (+)	CASS, LM-STAR, SAME, IAIS, C17	“	14	B 20
DIGITAL CH 372 (–)	“	“	14	A 20
DIGITAL CH 373 (+)	“	“	14	A 21
DIGITAL CH 373 (–)	“	“	14	B 21
DIGITAL CH 374 (+)	“	“	14	B 22
DIGITAL CH 374 (–)	“	“	14	A 22
DIGITAL CH 375 (+)	“	“	14	A 23
DIGITAL CH 375 (–)	“	“	14	B 23
DIGITAL CH 376 (+)	“	“	14	B 24
DIGITAL CH 376 (–)	“	“	14	A 24
DIGITAL CH 377 (+)	“	“	14	A 25
DIGITAL CH 377 (–)	“	“	14	B 25
DIGITAL CH 378 (+)	“	“	14	B 26
DIGITAL CH 378 (–)	“	“	14	A 26
DIGITAL CH 379 (+)	“	“	14	A 27
DIGITAL CH 379 (–)	“	“	14	B 27
DIGITAL CH 380 (+)	“	“	14	B 28

Table A.21—Digital channels (*continued*)

CTI name	Legacy system	Recommended attributes	Slot	Pin
DIGITAL CH 380 (-)	“	“	14	A 28
DIGITAL CH 381 (+)	“	“	14	A 29
DIGITAL CH 381 (-)	“	“	14	B 29
DIGITAL CH 382 (+)	“	“	14	B 30
DIGITAL CH 382 (-)	“	“	14	A 30
DIGITAL CH 383 (+)	“	“	14	A 31
DIGITAL CH 383 (-)	“	“	14	B 31
DIGITAL CH 384 (+)	“	“	14	B 32
DIGITAL CH 384 (-)	“	“	14	A 32
DIGITAL CH 385 (+)	C17	“	14	A 33
DIGITAL CH 385 (-)	“	“	14	B 33
DIGITAL CH 386 (+)	“	“	14	B 34
DIGITAL CH 386 (-)	“	“	14	A 34
DIGITAL CH 387 (+)	“	“	14	A 35
DIGITAL CH 387 (-)	“	“	14	B 35
DIGITAL CH 388 (+)	“	“	14	B 36
DIGITAL CH 388 (-)	“	“	14	A 36
DIGITAL CH 389 (+)	“	“	14	A 37
DIGITAL CH 389 (-)	“	“	14	B 37
DIGITAL CH 390 (+)	“	“	14	B 38
DIGITAL CH 390 (-)	“	“	14	A 38
DIGITAL CH 391 (+)	“	“	14	A 39
DIGITAL CH 391 (-)	“	“	14	B 39
DIGITAL CH 392 (+)	“	“	14	B 40
DIGITAL CH 392 (-)	“	“	14	A 40
DIGITAL CH 393 (+)	“	“	14	A 41
DIGITAL CH 393 (-)	“	“	14	B 41
DIGITAL CH 394 (+)	“	“	14	B 42
DIGITAL CH 394 (-)	“	“	14	A 42
DIGITAL CH 395 (+)	“	“	14	A 43
DIGITAL CH 395 (-)	“	“	14	B 43
DIGITAL CH 396 (+)	“	“	14	B 44
DIGITAL CH 396 (-)	“	“	14	A 44
DIGITAL CH 397 (+)	“	“	14	A 45
DIGITAL CH 397 (-)	“	“	14	B 45
DIGITAL CH 398 (+)	“	“	14	B 46
DIGITAL CH 398 (-)	“	“	14	A 46
DIGITAL CH 399 (+)	“	“	14	A 47
DIGITAL CH 399 (-)	“	“	14	B 47
DIGITAL CH 400 (+)	“	“	14	B 48
DIGITAL CH 400 (-)	“	“	14	A 48
DIGITAL CH 401 (+)	“	“	14	C 1
DIGITAL CH 401 (-)	“	“	14	D 1
DIGITAL CH 402 (+)	“	“	14	D 2
DIGITAL CH 402 (-)	“	“	14	C 2
DIGITAL CH 403 (+)	“	“	14	C 3
DIGITAL CH 403 (-)	“	“	14	D 3
DIGITAL CH 404 (+)	“	“	14	D 4
DIGITAL CH 404 (-)	“	“	14	C 4
DIGITAL CH 405 (+)	“	“	14	C 5
DIGITAL CH 405 (-)	“	“	14	D 5
DIGITAL CH 406 (+)	“	“	14	D 6

**Table A.21—Digital channels (continued)**

CTI name	Legacy system	Recommended attributes	Slot	Pin
DIGITAL CH 406 (-)	“	“	14	C 6
DIGITAL CH 407 (+)	“	“	14	C 7
DIGITAL CH 407 (-)	“	“	14	D 7
DIGITAL CH 408 (+)	“	“	14	D 8
DIGITAL CH 408 (-)	“	“	14	C 8
DIGITAL CH 409 (+)	“	“	14	C 9
DIGITAL CH 409 (-)	“	“	14	D 9
DIGITAL CH 410 (+)	“	“	14	D 10
DIGITAL CH 410 (-)	“	“	14	C 10
DIGITAL CH 411 (+)	“	“	14	C 11
DIGITAL CH 411 (-)	“	“	14	D 11
DIGITAL CH 412 (+)	“	“	14	D 12
DIGITAL CH 412 (-)	“	“	14	C 12
DIGITAL CH 413 (+)	“	“	14	C 13
DIGITAL CH 413 (-)	“	“	14	D 13
DIGITAL CH 414 (+)	“	“	14	D 14
DIGITAL CH 414 (-)	“	“	14	C 14
DIGITAL CH 415 (+)	“	“	14	C 15
DIGITAL CH 415 (-)	“	“	14	D 15
DIGITAL CH 416 (+)	“	“	14	D 16
DIGITAL CH 416 (-)	“	“	14	C 16
DIGITAL CH 417 (+)	C17	“	14	C 17
DIGITAL CH 417 (-)	“	“	14	D 17
DIGITAL CH 418 (+)	“	“	14	D 18
DIGITAL CH 418 (-)	“	“	14	C 18
DIGITAL CH 419 (+)	“	“	14	C 19
DIGITAL CH 419 (-)	“	“	14	D 19
DIGITAL CH 420 (+)	“	“	14	D 20
DIGITAL CH 420 (-)	“	“	14	C 20
DIGITAL CH 421 (+)	“	“	14	C 21
DIGITAL CH 421 (-)	“	“	14	D 21
DIGITAL CH 422 (+)	“	“	14	D 22
DIGITAL CH 422 (-)	“	“	14	C 22
DIGITAL CH 423 (+)	“	“	14	C 23
DIGITAL CH 423 (-)	“	“	14	D 23
DIGITAL CH 424 (+)	“	“	14	D 24
DIGITAL CH 424 (-)	“	“	14	C 24
DIGITAL CH 425 (+)	“	“	14	C 25
DIGITAL CH 425 (-)	“	“	14	D 25
DIGITAL CH 426 (+)	“	“	14	D 26
DIGITAL CH 426 (-)	“	“	14	C 26
DIGITAL CH 427 (+)	“	“	14	C 27
DIGITAL CH 427 (-)	“	“	14	D 27
DIGITAL CH 428 (+)	“	“	14	D 28
DIGITAL CH 428 (-)	“	“	14	C 28
DIGITAL CH 429 (+)	“	“	14	C 29
DIGITAL CH 429 (-)	“	“	14	D 29
DIGITAL CH 430 (+)	“	“	14	D 30
DIGITAL CH 430 (-)	“	“	14	C 30
DIGITAL CH 431 (+)	“	“	14	C 31
DIGITAL CH 431 (-)	“	“	14	D 31
DIGITAL CH 432 (+)	“	“	14	D 32

Table A.21—Digital channels (*continued*)

CTI name	Legacy system	Recommended attributes	Slot	Pin
DIGITAL CH 432 (-)	“	“	14	C 32
DIGITAL CH 433 (+)	“	“	14	C 33
DIGITAL CH 433 (-)	“	“	14	D 33
DIGITAL CH 434 (+)	“	“	14	D 34
DIGITAL CH 434 (-)	“	“	14	C 34
DIGITAL CH 435 (+)	“	“	14	C 35
DIGITAL CH 435 (-)	“	“	14	D 35
DIGITAL CH 436 (+)	“	“	14	D 36
DIGITAL CH 436 (-)	“	“	14	C 36
DIGITAL CH 437 (+)	“	“	14	C 37
DIGITAL CH 437 (-)	“	“	14	D 37
DIGITAL CH 438 (+)	“	“	14	D 38
DIGITAL CH 438 (-)	“	“	14	C 38
DIGITAL CH 439 (+)	“	“	14	C 39
DIGITAL CH 439 (-)	“	“	14	D 39
DIGITAL CH 440 (+)	C17	“	14	D 40
DIGITAL CH 440 (-)	“	“	14	C 40
DIGITAL CH 441 (+)	“	“	14	C 41
DIGITAL CH 441 (-)	“	“	14	D 41
DIGITAL CH 442 (+)	“	“	14	D 42
DIGITAL CH 442 (-)	“	“	14	C 42
DIGITAL CH 443 (+)	“	“	14	C 43
DIGITAL CH 443 (-)	“	“	14	D 43
DIGITAL CH 444 (+)	“	“	14	D 44
DIGITAL CH 444 (-)	“	“	14	C 44
DIGITAL CH 445 (+)	“	“	14	C 45
DIGITAL CH 445 (-)	“	“	14	D 45
DIGITAL CH 446 (+)	“	“	14	D 46
DIGITAL CH 446 (-)	“	“	14	C 46
DIGITAL CH 447 (+)	“	“	14	C 47
DIGITAL CH 447 (-)	“	“	14	D 47
DIGITAL CH 448 (+)	“	“	14	D 48
DIGITAL CH 448 (-)	“	“	14	C 48

**Table A.22—Clocks**

CTI name	Legacy systems	Recommended attributes	Slot	Pin
TOCYCLE+	CASS, LM-STAR, TETS, IAIS, C17, RAF	Max voltage: Diff ECL Max freq: 20 MHz	23,24	H 11
TOCYCLE-	“	“	23,24	H 12
EXTCLK+	“	“	23,24	H 13
EXTCLK-	“	“	23,24	H 14
FEXCLK+	CASS, LM-STAR, IAIS, C17, RAF	Max voltage: Diff ECL Max freq: 50 MHz	23,24	H 15
FEXCLK-	“	“	23,24	H 16
CLUTCH1+	CASS, LM-STAR, TETS, IAIS, C17, RAF	“	23,24	H 17
CLUTCH1-	“	“	23,24	H 18
CLUTCH2+	“	“	23,24	H 19
CLUTCH2-	“	“	23,24	G 11
EXT1	CASS, LM-STAR, IAIS, C17, RAF	“	23,24	G 12
EXT2	“	“	23,24	G 13
EXT REF+	“	Voltage: -1.29 V Max freq: 50 MHz	23,24	G 14
EXT REF-	“	“	23,24	G 14
SYNC 1+	TETS, C17, RAF	ECL: 20 MHz	23,24	G 15
SYNC 1 -	“	“	23,24	G 15
SYNC 2 +	“	“	23,24	G 16
SYNC 2 -	“	“	23,24	G 16
SYNC 3 +	“	“	23,24	G 17
SYNC 3 -	“	“	23,24	G 17
SYNC 4 +	“	“	23,24	G 18
SYNC 4 -	“	“	23,24	G 18
Clock 1 +	“	“	23,24	F 16
Clock 1 -	“	“	23,24	F 16
Clock 2 +	“	“	23,24	F 17
Clock 2 -	“	“	23,24	F 17
Clock 3 +	“	“	23,24	F 18
Clock 3 -	“	“	23,24	F 18
Clock 4 +	“	“	23,24	F 19
Clock 4 -	“	“	23,24	F 19
Kelvin ground 4			23, 24	G 19

Table A.23—External control

CTI name	Legacy systems	Recommended attributes	Slot	Pin
ExtCtrl CH 1 (+)	RAF	Voltage: TTL Max freq: 50 MHz Impedance: 50 $\Omega$ Max current: 60 mA	27	A 1
ExtCtrl CH 1 (–)	“	“	27	B 1
ExtCtrl CH 2 (+)	“	“	27	B 2
ExtCtrl CH 2 (–)	“	“	27	A 2
ExtCtrl CH 3 (+)	IFTE, ESTS, RAF	“	27	A 3
ExtCtrl CH 3 (–)	“	“	27	B 3
ExtCtrl CH 4 (+)	“	“	27	B 4
ExtCtrl CH 4 (–)	“	“	27	A 4
ExtCtrl CH 5 (+)	IFTE, ESTS	“	27	A 5
ExtCtrl CH 5 (–)	“	“	27	B 5
ExtCtrl CH 6 (+)	“	“	27	B 6
ExtCtrl CH 6 (–)	“	“	27	A 6
ExtCtrl CH 7 (+)	IFTE, ESTS, RAF	“	27	A 7
ExtCtrl CH 7 (–)	“	“	27	B 7
ExtCtrl CH 8 (+)	ESTS	“	27	B 8
ExtCtrl CH 8 (–)	“	“	27	A 8
ExtCtrl CH 9 (+)	IFTE	“	27	A 9
ExtCtrl CH 9 (–)	“	“	27	B 9
ExtCtrl CH 10 (+)	ESTS	“	27	B 10
ExtCtrl CH 10 (–)	“	“	27	A 10
ExtCtrl CH 11 (+)	IFTE	“	27	A 11
ExtCtrl CH 11 (–)	“	“	27	B 11
ExtCtrl CH 12 (+)	IFTE, ESTS	“	27	B 12
ExtCtrl CH 12 (–)	“	“	27	A 12
ExtCtrl CH 13 (+)	“	“	27	A 13
ExtCtrl CH 13 (–)	“	“	27	B 13
ExtCtrl CH 14 (+)	IFTE	“	27	B 14
ExtCtrl CH 14 (–)	“	“	27	A 14
ExtCtrl CH 15 (+)	IFTE, ESTS	“	27	A 15
ExtCtrl CH 15 (–)	“	“	27	B 15
ExtCtrl CH 16 (+)	“	“	27	B 16
ExtCtrl CH 16 (–)	“	“	27	A 16
ExtCtrl CH 17 (+)	IFTE	“	27	A 17
ExtCtrl CH 17 (–)	“	“	27	B 17
ExtCtrl CH 18 (+)	ESTS	“	27	B 18
ExtCtrl CH 18 (–)	“	“	27	A 18
ExtCtrl CH 19 (+)	IFTE	“	27	A 19
ExtCtrl CH 19 (–)	“	“	27	B 19
ExtCtrl CH 20 (+)	“	“	27	B 20
ExtCtrl CH 20 (–)	“	“	27	A 20
ExtCtrl CH 21 (+)	“	“	27	A 21
ExtCtrl CH 21 (–)	“	“	27	B 21
ExtCtrl CH 22 (+)	“	“	27	B 22
ExtCtrl CH 22 (–)	“	“	27	A 22
ExtCtrl CH 23 (+)	“	“	27	A 23
ExtCtrl CH 23 (–)	“	“	27	B 23

**Table A.23—External control (continued)**

CTI name	Legacy systems	Recommended attributes	Slot	Pin
ExtCtrl CH 24 (+)	IFTE, ESTS	“	27	B 24
ExtCtrl CH 24 (–)	“	“	27	A 24
ExtCtrl CH 25 (+)	“	“	27	A 25
ExtCtrl CH 25 (–)	“	“	27	B 25
ExtCtrl CH 26 (+)	IFTE	“	27	B 26
ExtCtrl CH 26 (–)	“	“	27	A 26
ExtCtrl CH 27 (+)	“	“	27	A 27
ExtCtrl CH 27 (–)	“	“	27	B 27
ExtCtrl CH 28 (+)	“	“	27	C 1
ExtCtrl CH 28 (–)	“	“	27	D 1
ExtCtrl CH 29 (+)	“	“	27	D 2
ExtCtrl CH 29 (–)	“	“	27	C 2
ExtCtrl CH 30 (+)	“	“	27	C 3
ExtCtrl CH 30 (–)	“	“	27	D 3
ExtCtrl CH 31 (+)	“	“	27	D 4
ExtCtrl CH 31 (–)	“	“	27	C 4
ExtCtrl CH 32 (+)	“	“	27	C 5
ExtCtrl CH 32 (–)	“	“	27	D 5
ExtCtrl CH 33 (+)	“	“	27	D 6
ExtCtrl CH 33 (–)	“	“	27	C 6
ExtCtrl CH 34 (+)	“	“	27	C 7
ExtCtrl CH 34 (–)	“	“	27	D 7
ExtCtrl CH 35 (+)	“	“	27	D 8
ExtCtrl CH 35 (–)	“	“	27	C 8
ExtCtrl CH 36 (+)	“	“	27	C 9
ExtCtrl CH 36 (–)	“	“	27	D 9
ExtCtrl CH 37 (+)	“	“	27	D 10
ExtCtrl CH 37 (–)	“	“	27	C 10
ExtCtrl CH 38 (+)	“	“	27	C 11
ExtCtrl CH 38 (–)	“	“	27	D 11
ExtCtrl CH 39 (+)	“	“	27	D 12
ExtCtrl CH 39 (–)	“	“	27	C 12
ExtCtrl CH 40 (+)	“	“	27	C 13
ExtCtrl CH 40 (–)	“	“	27	D 13
ExtCtrl CH 41 (+)	“	“	27	D 14
ExtCtrl CH 41 (–)	“	“	27	C 14
ExtCtrl CH 42 (+)	“	“	27	C 15
ExtCtrl CH 42 (–)	“	“	27	D 15
ExtCtrl CH 43 (+)	“	“	27	D 16
ExtCtrl CH 43 (–)	“	“	27	C 16
ExtCtrl CH 44 (+)	“	“	27	C 17
ExtCtrl CH 44 (–)	“	“	27	D 17
ExtCtrl CH 45 (+)	“	“	27	D 18
ExtCtrl CH 45 (–)	“	“	27	C 18
ExtCtrl CH 46 (+)	“	“	27	C 19
ExtCtrl CH 46 (–)	“	“	27	D 19
ExtCtrl CH 47 (+)	“	“	27	D 20
ExtCtrl CH 47 (–)	“	“	27	C 20
ExtCtrl CH 48 (+)	“	“	27	C 21
ExtCtrl CH 48 (–)	“	“	27	D 21
ExtCtrl CH 49 (+)	“	“	27	D 22
ExtCtrl CH 49 (–)	“	“	27	C 22



**Table A.23—External control (continued)**

CTI name	Legacy systems	Recommended attributes	Slot	Pin
ExtCtrl CH 50 (+)	None	“	27	C 23
ExtCtrl CH 50 (–)	None	“	27	D 23
ExtCtrl CH 51 (+)	None	“	27	D 24
ExtCtrl CH 51 (–)	None	“	27	C 24
ExtCtrl CH 52 (+)	IFTE	“	27	C 25
ExtCtrl CH 52 (–)	“	“	27	D 25
ExtCtrl CH 53 (+)	“	“	27	D 26
ExtCtrl CH 53 (–)	“	“	27	C 26
ExtCtrl CH 54 (+)	“	“	27	C 27
ExtCtrl CH 54 (–)	“	“	27	D 27

**Table A.24—Spectrum analyzer**

CTI name	Legacy systems	Recommended attributes	Slot	Pin
Spec An Trig	IFTE, ESTS, TETS, RAF	Freq: 3 GHz Impedance: 50 $\Omega$ Voltage: –120 to 30 dBm	21,22	C 12
Spec An Det Video	IFTE, ESTS, RAF	“	21,22	D 12
Spec An RFMEAS IN	TETS, RAF	“	21,22	E 12
321.4 MHz IF	CASS, LM-STAR	Voltage: $\pm$ 8 V Current: 1 A Freq: 160 MHz Impedance: 50 $\Omega$	21,22	D 13

**Table A.25—Modulation source**

CTI name	Legacy systems	Recommended attributes	Slot	Pin
RF Mod Src 1 PM	ESTS, TETS, RAF	Freq: 3 GHz Impedance: 50 $\Omega$ Voltage: –120 to 30 dBm	21,22	B 15
RF Mod Src 1 AM	ESTS, TETS, RAF	“	21,22	B 16
RF Mod Src 1 FM	“	“	21,22	B 17
AM-MOD Src 2	ESTS, RAF	“	21,22	C 15
PAM-MOD Src 2	“	“	21,22	C 16
FM-MOD Src 2	ESTS	“	21,22	C 17
PAM-MOD/PAM-TRIG Src 3	RAF	“	21,22	D 15
AM-MOD Src 3	“	“	21,22	D 16
FM-MOD Src 3	None	“	21,22	D 17
Stim 1 Ext. Trig. IN	C17	Contractor specific	21,22	E 13
Stim 2 Ext. Trig. IN	“	“	21,22	E 14
Stim 3 Ext. Trig. IN	“	“	21,22	E 15
MTA Ext. Trig. IN	C17	“	21,22	E 16

**Table A.26—Power meter**

CTI name	Legacy systems	Recommended attributes	Slot	Pin
Power Meter Recorder	TETS	Freq: 3 GHz Impedance: 50 $\Omega$ Voltage: -120 to 30 dBm	21,22	B 11
Power Meter Ext Trig In	CASS, LM-STAR, TETS	Freq: 106 MHz Impedance: 50 $\Omega$ Current: 1 A Voltage: $\pm$ 8 V	21,22	C 11
Power Meter Video1 Out	LM-STAR, RAF	Freq: 3 GHz Impedance: 50 $\Omega$ Voltage: -120 to 30 dBm	21,22	D 11
Power Meter Video2 Out	LM-STAR	“	21,22	E 11

**Table A.27—Hi current dc load**

CTI name	Comments	Recommended attributes	Slot	Pin
High Current Load 1A (+)	IFTE, CASS	Max current: 30 A Max voltage: 500 V Max power: 750 W (See NOTE)	1,2	B 16
High Current Load 1B (+)	“		1,2	A 17
High Current Load 1A (-)	“	“	1,2	A 16
High Current Load 1B (-)	“		1,2	B 17
High Current Load 2A (+)	IFTE	Max current: 30 A Max voltage: 50 V (See NOTE)	1,2	B 18
High Current Load 2B (+)	“		1,2	A 19
High Current Load 2A (-)	“	“	1,2	A 18
High Current Load 2B (-)	“		1,2	B 19

NOTE—Pins are tied together to handle maximum current.

**Table A.28—AC/DC load**

CTI name	Legacy systems	Recommended attributes	Slot	Pin
DC Load 3 (+)	IFTE, ESTS	Max voltage: 50 Vdc or 50 Vrms Max current: 15 A Max power: 300 W	1,2	D 16
DC Load 3 (–)	“		1,2	C 16
DC Load 4 (+)	IFTE	Max voltage: 50 Vdc or 50 Vrms Max current: 15 A Max power: 300 W	1,2	C 17
DC Load 4 (–)	“		1,2	D 17
DC Load 5 (+)	“	Max voltage: 130 Vdc or 130 Vrms Max current: 15 A Max power: 750 W	1,2	D 18
DC Load 5 (–)	“	Max voltage: 130 Vdc or 130 Vrms Max current: 15 A Max power: 750 W	1,2	C 18
DC Load 6 (+)	“	Max voltage: 130 Vdc or 130 Vrms Max current: 15 A Max power: 750 W	1,2	C 19
DC Load 6 (–)	“	Max voltage: 130 Vdc or 130 Vrms Max current: 15 A Max power: 750 W	1,2	D 19
DC Load 7 (+)	“	Max voltage: 130 Vdc or 130 Vrms Max current: 15 A Max power: 750 W	29	A 17
DC Load 7 (–)	“	Max voltage: 130 Vdc or 130 Vrms Max current: 15 A Max power: 750 W	29	A 18
DC Load 8 (+)	“	Max voltage: 250 Vdc or 250 Vrms Max current: 5 A Max power: 750 W	29	A 19
DC Load 8 (–)	“	“	29	A 20

**Table A.29—Load modulation**

CTI name	Legacy system	Recommended attributes	Slot	Pin
Load Modulation Control (+)	IFTE, RAF	Max voltage: 10 V Freq range: dc – 8 kHz Max current: 100 mA	1,2	E 19
Load Modulation Control (–)	“	“	1,2	E 18

**Table A.30—High current DCPS**

CTI name	Legacy system	Recommended attributes	Slot	Pin
High Current DCPS 1(A+)	IFTE, CASS, LM-STAR, ESTS, TETS, IAIS, C17, RAF	Max voltage: 50 V Max current: 33 A (See NOTE)	6	A 1
High Current DCPS 1(B+)			6	B 2
High Current DCPS 1A(-)			6	B 1
High Current DCPS 1B(-)			6	A 2
High Current DCPS 2A(+)	CASS, LM-STAR, ESTS, TETS, IAIS, C17	Max voltage: 50 V Max current: 33 A (See NOTE)	6	A 3
High Current DCPS 2B(+)			6	B 4
High Current DCPS 2A(-)			6	B 3
High Current DCPS 2B(-)			6	A 4
High Current DCPS 3A(+)	CASS, LM-STAR, ESTS, IAIS, C17	Max voltage: 50 V Max current: 33 A (See NOTE)	6	A 5
High Current DCPS 3B(+)			6	B 6
High Current DCPS 3A(-)			6	B 5
High Current DCPS 3B(-)			6	A 6
High Current DCPS 4A(+)	“	Max voltage: 50 V Max current: 33 A (See NOTE)	6	A 7
High Current DCPS 4B(+)			6	B 8
High Current DCPS 4A(-)			6	B 7
High Current DCPS 4B(-)			6	A 8
High Current DCPS 5 A(+)	“	Max voltage: 50 V Max current: 33 A (See NOTE)	6	A 9
High Current DCPS 5B(+)			6	B 10
High Current DCPS 5 A(-)			6	B 9
High Current DCPS 5B(-)			6	A 10
High Current DCPS 6A(+)	CASS, LM-STAR, IAIS	Max voltage: 50 V Max current: 33 A (See NOTE)	6	A 11
High Current DCPS 6B(+)			6	B 12
High Current DCPS 6A(-)			6	B 11
High Current DCPS 6B(-)			6	A 12
High Current DCPS 7A(+)	“	Max voltage: 50 V Max current: 33 A (See NOTE)	6	A 13
High Current DCPS 7B(+)			6	B 14
High Current DCPS 7A(-)			6	B 13
High Current DCPS 7B(-)			6	A 14
High Current DCPS 8A(+)	“	Max voltage: 50 V Max current: 33 A (See NOTE)	6	A 15
High Current DCPS 8B(+)			6	B 16
High Current DCPS 8A(-)			6	B 15
High Current DCPS 8B(-)			6	A 16
High Current DCPS 9A(+)	IFTE	Max voltage: 16V Max current: 21 A (See NOTE)	1,2	H 18
High Current DCPS 9B(+)			1,2	G 19
High Current DCPS 9A(-)			1,2	G 18
High Current DCPS 9B(-)			1,2	H 19
High Current DCPS 10A(+)	IFTE	Max voltage: 16V Max current: 21 A (See NOTE)	29	C 17
High Current DCPS 10B(+)			29	C 19
High Current DCPS 10A(-)			29	C 18
High Current DCPS 10B(-)			29	C 20

NOTE—Pins are tied together to handle maximum current.

Table A.31—DCPS

CTI name	Legacy systems	Recommended attributes	Slot	Pin
DCPS 11(+)	IFTE, CASS, LM-STAR, ESTS, TETS, C17, RAF	Max voltage: 100 V Max current: 5 A	6	A 17
DCPS 11(-)	“	Max voltage: 100 V Max current: 5 A	6	A 18
DCPS 12(+)	IFTE, CASS, LM-STAR, ESTS, TETS, IAIS, RAF	Max voltage: 100 V Max current: 5 A	6	B 18
DCPS 12(-)	“	Max voltage: 100 V Max current: 5 A	6	B 17
DCPS 13(+)	“	Max voltage: 100 V Max current: 5 A	6	C 1
DCPS 13(-)	“	Max voltage: 100 V Max current: 5 A	6	C 2
DCPS 14(+)	IFTE, CASS, ESTS, TETS, RAF	Max voltage: 100 V Max current: 5 A	6	C 3
DCPS 14(-)	“	Max voltage: 100 V Max current: 5 A	6	C 4
DCPS 15(+)	IFTE, ESTS, TETS, RAF	Max voltage: 100 V Max current: 5 A	6	C 5
DCPS 15(-)	“	Max voltage: 100 V Max current: 5 A	6	C 6
DCPS 16(+)	“	Max voltage: 100 V Max current: 5 A	6	C 7
DCPS 16(-)	“	Max voltage: 100 V Max current: 5 A	6	C 8
DCPS 17(+)	“	Max voltage: 100 V Max current: 5 A	6	C 9
DCPS 17(-)	“	Max voltage: 100 V Max current: 5 A	6	C 10
DCPS 18(+)	“	Max voltage: 100 V Max current: 5 A	6	C 11
DCPS 18(-)	“	Max voltage: 100 V Max current: 5 A	6	C 12
DCPS 19(+)	IFTE, ESTS, TETS	Max voltage: 100 V Max current: 5 A	6	C 13
DCPS 19(-)	“	Max voltage: 100 V Max current: 5 A	6	C 14
DCPS 20(+)	CASS	Max voltage: 450 V Max current: 15 A	6	C 15
DCPS 20(-)	“	Max voltage: 450 V Max current: 15 A	6	C 16
DCPS 21(+)	“	Max voltage: 450 V Max current: 15 A	6	C 17
DCPS 21(-)	“	Max voltage: 450 V Max current: 15 A	6	C 18
DCPS 22(+)	“	Max voltage: 100 V Max current: 5 A	1,2	F 18
DCPS 22(-)	“	Max voltage: 100 V Max current: 5 A	1,2	F 19

**Table A.32—ACPS 3 phase**

CTI name	Legacy system	Recommended attributes	Slot	Pin
Fixed 3 Phase PHA1	CASS, LM-STAR, IAIS	Max voltage: 115 Vac	1,2	A 1
		Max current: 30 A		
Fixed 3 Phase PHA2	“	Max freq: 400 Hz (See NOTE)	1,2	B 1
Fixed 3 Phase PHB1		Max voltage: 115 Vac	1,2	A 2
	“	Max current: 30 A		
Fixed 3 Phase PHB2		Max freq: 400 Hz (See NOTE)	1,2	B 2
Fixed 3 Phase PHC1	“	Max voltage: 115 Vac	1,2	A 3
		Max current: 30 A		
Fixed 3 Phase PHC2	“	Max freq: 400 Hz (See NOTE)	1,2	B 3
Fixed 3 Phase N1		Max voltage: 115 Vac	1,2	A 4
	“	Max current: 30 A		
Fixed 3 Phase N2		Max freq: 400 Hz (See NOTE)	1,2	B 4
ACPS Chassis ground 1	“	Max voltage: 115 Vac	1,2	A 5
		Max current: 30 A		
ACPS Chassis ground 2	“	Max freq: 400 Hz (See NOTE)	1,2	B 5

NOTE—Pins are tied together to handle maximum current.

**Table A.33—ACPS programmable**

CTI name	Legacy systems	Recommended attributes	Slot	Pin
Programmable ACPS1 Phase	IFTE, CASS, LM-STAR, IAIS, C17, RAF	Max voltage: 270 Vac Max current: 10 A Freq range: 45 Hz to 5000 Hz	6	A 19
Programmable ACPS1 Return	“	“	6	B 19
Programmable ACPS2 Phase	IFTE, CASS, ESTS, IAIS, C17	“	1,2	C 1
Programmable ACPS2 Return	“	“	1,2	D 1
Programmable ACPS3 Phase	IFTE, CASS, ESTS, IAIS, C17	“	1,2	D 2
Programmable ACPS3 Return	“	“	1,2	C 2
Programmable ACPS4 Phase	IFTE, CASS, ESTS	“	1,2	C 3
Programmable ACPS4 Return	“	“	1,2	D 3
ACPS Chassis ground 3	IFTE, CASS, LM-STAR, ESTS, IAIS, C17	“	1,2	D 4
ACPS Chassis ground 4	IFTE, CASS, LM-STAR, ESTS, IAIS	“	1,2	C 4
Aux. Phase A	ESTS	Max voltage: 30.5 V Max current: 2 A Freq: 400 Hz	28	C47
Aux. Phase A Return	“	“	28	D47
Aux. Phase B	“	“	28	D48
Aux. Phase B Return	“	“	28	C48
Aux. Phase C	“	“	28	C49
Aux. Phase C Return	“	“	28	D49
Aux. Phase D	“	“	28	D50
Aux. Phase D Return	“	“	28	C50

**Table A.34—DCPS sense**

CTI name	Legacy systems	Recommended attributes	Slot	Pin
Sense DCPS1 (+)	IFTE, CASS, LM-STAR, ESTS, TETS, IAIS, C17, RAF	Max voltage: 50 V Current: 0.5 A	7	A 1
Sense DCPS1 (-)	“	“	7	B 1
Sense DCPS2 (+)	CASS, LM-STAR, ESTS, TETS, IAIS, C17	“	7	B 2
Sense DCPS2 (-)	“	“	7	A 2
Sense DCPS3 (+)	CASS, LM-STAR, ESTS, IAIS, C17	“	7	A 3
Sense DCPS3 (-)	“	“	7	B 3
Sense DCPS4 (+)	“	“	7	B 4
Sense DCPS4 (-)	“	“	7	A 4
Sense DCPS5 (+)	CASS, LM-STAR, ESTS, C17	“	7	C 1
Sense DCPS5 (-)	“	“	7	D 1
Sense DCPS6 (+)	CASS, LM-STAR	“	7	D 2
Sense DCPS6 (-)	“	“	7	C 2
Sense DCPS7 (+)	“	“	7	C 3
Sense DCPS7 (-)	“	“	7	D 3
Sense DCPS8 (+)	“	“	7	D 4
Sense DCPS8 (-)	“	“	7	C 4
Sense DCPS9 (+)	IFTE, LM-STAR, IAIS, C17	Max voltage: 16 V Current: 0.5 A	8	A 1
Sense DCPS9 (-)	“	“	8	B 1
Sense DCPS10 (+)	IFTE, LM-STAR, IAIS	“	8	B 2
Sense DCPS10 (-)	“	“	8	A 2
Sense DCPS11 (+)	IFTE, CASS, LM-STAR, ESTS, TETS, IAIS, RAF	Max voltage: 100 V Current: 0.5 A	8	A 3
Sense DCPS11 (-)	“	“	8	B 3
Sense DCPS12 (+)	TETS, RAF	“	8	B 4
Sense DCPS12 (-)	“	“	8	A 4
Sense DCPS13 (+)	IFTE, CASS, TETS, RAF	“	8	A 5
Sense DCPS13 (-)	“	“	8	B 5
Sense DCPS14 (+)	ESTS, TETS, RAF	“	8	B 6
Sense DCPS14 (-)	“	“	8	A 6
Sense DCPS15 (+)	IFTE, TETS, RAF	“	8	A 7
Sense DCPS15 (-)	“	“	8	B 7
Sense DCPS16 (+)	“	“	8	B 8
Sense DCPS16 (-)	“	“	8	A 8
Sense DCPS17 (+)	IFTE, ESTS, TETS, RAF	“	8	A 9
Sense DCPS17 (-)	“	“	8	B 9
Sense DCPS18 (+)	IFTE, TETS	“	8	B 10
Sense DCPS18 (-)	“	“	8	A 10
Sense DCPS19 (+)	“	“	8	A 11
Sense DCPS19 (-)	“	“	8	B 11
Sense DCPS20 (+)	CASS	Max voltage: 450 V Current: 0.5 A	3	A 46
Sense DCPS20 (-)	“	“	3	B 46
Sense DCPS21 (+)	“	“	3	B 47
Sense DCPS21 (-)	“	“	3	A 47
Sense DCPS22 (+)	“	Max voltage: 100 V Current: 0.5 A	28	A 43
Sense DCPS22 (-)	“	“	28	B 43



**Table A.35—ACPS sense**

CTI name	Legacy systems	Recommended attributes	Slot	Pin
Sense ACPS1 Phase	IFTE, CASS, LM-STAR, IAIS, C17	Max voltage: 270 Vac Max current: 0.5 A Freq range: 45 Hz to 5000 Hz	1,2	C 5
Sense ACPS1 Return	“	“	1,2	D 5
Sense ACPS2 Phase	IFTE, CASS, ESTS, IAIS, C17	“	1,2	D 6
Sense ACPS2 Return	“	“	1,2	C 6
Sense ACPS3 Phase	“	“	1,2	C 7
Sense ACPS3 Return	“	“	1,2	D 7
Sense ACPS4 Phase	IFTE, CASS, ESTS	“	1,2	D 8
Sense ACPS4 Return	“	“	1,2	C 8

**Table A.36—Load sense**

CTI name	Legacy systems	Recommended attributes	Slot	Pin
Load Sense (+)	CASS, LM-STAR	Max voltage: 500 V Max current: 500 mA	3	A 48
Load Sense (-)	“	“	3	B 48
Load Chassis ground 1	LM-STAR	N/A	3	A 49
Load Chassis ground 2	“	N/A	3	B 49

**Table A.37—28 V control**

CTI name	Legacy systems	Recommended attributes	Slot	Pin
28 V Control (+)	IFTE, CASS, ESTS, TETS	Max voltage: 28 V Current: 1 A	19	B 50
28 V Control (-)	“	“	19	A 50

**Table A.38—Coax 1x4 switch**

CTI name	Legacy systems	Recommended attributes	Slot	Pin
Coax 2x8 MUX 01 (or 1x4 sw 01)	IFTE, CASS, LM-STAR, ESTS, TETS, RAF	Impedance: 50 $\Omega$ Freq range: dc to 1 GHz Max power: 2 W Max Capacitance: 15 pF VSWR Max: (@ 1 GHz) 1.15+0.01f(GHz) RF leakage: -60 db @ 1Ghz Bandwidth: 100 MHz to 1.2 GHz Path Resistance: <2 $\Omega$ @ 1 mA Current: 2 A	4	A 1
Coax 2x8 MUX 01 (or 1x4 sw 01)	IFTE, CASS, LM-STAR, ESTS, TETS, RAF	“	4	A 2
Coax 2x8 MUX 01 (or 1x4 sw 01)	IFTE, CASS, LM-STAR, ESTS, TETS, RAF	“	4	A 3
Coax 2x8 MUX 01 (or 1x4 sw 01)	IFTE, CASS, LM-STAR, ESTS, TETS	“	4	A 4
Coax 2x8 MUX 01 (or 1x4 sw 01)	IFTE, CASS, LM-STAR	“	4	A 5
Coax 2x8 MUX 01 (or 1x4 sw 02)	IFTE, CASS, LM-STAR, ESTS, RAF	“	4	A 6
Coax 2x8 MUX 01 (or 1x4 sw 02)	IFTE, CASS, LM-STAR, ESTS, TETS, RAF	“	4	A 7
Coax 2x8 MUX 01 (or 1x4 sw 02)	IFTE, CASS, LM-STAR, ESTS, TETS, RAF	“	4	A 8
Coax 2x8 MUX 01 (or 1x4 sw 02)	IFTE, CASS, LM-STAR, ESTS, TETS	“	4	A 9
Coax 2x8 MUX 01 (or 1x4 sw 02)	IFTE, CASS, LM-STAR	“	4	A 10
Coax 2x8 MUX 02 (or 1x4 sw 03)	IFTE, CASS, LM-STAR, ESTS, TETS, RAF	“	4	A 11
Coax 2x8 MUX 02 (or 1x4 sw 03)	IFTE, CASS, LM-STAR, ESTS, TETS, RAF	“	4	A 12
Coax 2x8 MUX 02 (or 1x4 sw 03)	IFTE, CASS, LM-STAR, ESTS, TETS, RAF	“	4	A 13
Coax 2x8 MUX 02 (or 1x4 sw 03)	IFTE, CASS, LM-STAR, ESTS, TETS	“	4	A 14
Coax 2x8 MUX 02 (or 1x4 sw 03)	IFTE, CASS, LM-STAR	“	4	A 15
Coax 2x8 MUX 02 (or 1x4 sw 04)	IFTE, CASS, LM-STAR, ESTS, RAF	“	4	A 16
Coax 2x8 MUX 02 (or 1x4 sw 04)	IFTE, CASS, LM-STAR, ESTS, TETS, RAF	“	4	A 17

**Table A.38—Coax 1x4 switch (continued)**

CTI name	Legacy systems	Recommended attributes	Slot	Pin
Coax 2x8 MUX 02 (or 1x4 sw 04)	IFTE, CASS, LM-STAR, ESTS, TETS, RAF	“	4	A 18
Coax 2x8 MUX 02 (or 1x4 sw 04)	IFTE, CASS, LM-STAR, ESTS, TETS	“	4	A 19
Coax 2x8 MUX 02 (or 1x4 sw 04)	IFTE, CASS, LM-STAR	“	4	A 20
Coax 2x8 MUX 03 (or 1x4 sw 05)	IFTE, CASS, LM-STAR, ESTS, TETS, RAF	“	4	B 1
Coax 2x8 MUX 03 (or 1x4 sw 05)	IFTE, CASS, LM-STAR, ESTS, TETS, RAF	“	4	B 2
Coax 2x8 MUX 03 (or 1x4 sw 05)	IFTE, CASS, LM-STAR, ESTS, TETS, RAF	“	4	B 3
Coax 2x8 MUX 03 (or 1x4 sw 05)	IFTE, CASS, LM-STAR, ESTS, TETS	“	4	B 4
Coax 2x8 MUX 03 (or 1x4 sw 05)	IFTE, CASS, LM-STAR	“	4	B 5
Coax 2x8 MUX 03 (or 1x4 sw 06)	IFTE, CASS, LM-STAR, ESTS, RAF	“	4	B 6
Coax 2x8 MUX 03 (or 1x4 sw 06)	IFTE, CASS, LM-STAR, ESTS, TETS, RAF	“	4	B 7
Coax 2x8 MUX 03 (or 1x4 sw 06)	IFTE, CASS, LM-STAR, ESTS, TETS, RAF	“	4	B 8
Coax 2x8 MUX 03 (or 1x4 sw 06)	IFTE, CASS, LM-STAR, ESTS, TETS	“	4	B 9
Coax 2x8 MUX 03 (or 1x4 sw 06)	IFTE, CASS, LM-STAR	“	4	B 10
Coax 2x8 MUX 04 (or 1x4 sw 07)	IFTE, CASS, LM-STAR, ESTS, TETS, RAF	“	4	B 11
Coax 2x8 MUX 04 (or 1x4 sw 07)	IFTE, CASS, LM-STAR, ESTS, TETS, RAF	“	4	B 12
Coax 2x8 MUX 04 (or 1x4 sw 07)	IFTE, CASS, LM-STAR, ESTS, TETS, RAF	“	4	B 13
Coax 2x8 MUX 04 (or 1x4 sw 07)	IFTE, CASS, LM-STAR, ESTS, TETS	“	4	B 14
Coax 2x8 MUX 04 (or 1x4 sw 07)	IFTE, CASS, LM-STAR	“	4	B 15
Coax 2x8 MUX 04 (or 1x4 sw 08)	IFTE, CASS, LM-STAR, ESTS, RAF	“	4	C 1

**Table A.38—Coax 1x4 switch (continued)**

CTI name	Legacy systems	Recommended attributes	Slot	Pin
Coax 2x8 MUX 04 (or 1x4 sw 08)	IFTE, CASS, LM-STAR, ESTS, TETS, RAF	“	4	C 2
Coax 2x8 MUX 04 (or 1x4 sw 08)	IFTE, CASS, LM-STAR, ESTS, TETS, RAF	“	4	C 3
Coax 2x8 MUX 04 (or 1x4 sw 08)	IFTE, CASS, LM-STAR, ESTS, TETS	“	4	C 4
Coax 2x8 MUX 04 (or 1x4 sw 08)	IFTE, CASS, LM-STAR	“	4	C 5
Coax 2x8 MUX 05 (or 1x4 sw 09)	IFTE, CASS, LM-STAR, ESTS, RAF	“	4	C 6
Coax 2x8 MUX 05 (or 1x4 sw 09)	IFTE, CASS, LM-STAR, ESTS, RAF	“	4	C 7
Coax 2x8 MUX 05 (or 1x4 sw 09)	IFTE, CASS, LM-STAR, ESTS, RAF	“	4	C 8
Coax 2x8 MUX 05 (or 1x4 sw 09)	IFTE, CASS, LM-STAR, ESTS	“	4	C 9
Coax 2x8 MUX 05 (or 1x4 sw 09)	IFTE, CASS, LM-STAR	“	4	C 10
Coax 2x8 MUX 05 (or 1x4 sw 10)	IFTE, CASS, LM-STAR	“	4	C 11
Coax 2x8 MUX 05 (or 1x4 sw 10)	IFTE, CASS, LM-STAR	“	4	C 12
Coax 2x8 MUX 05 (or 1x4 sw 10)	IFTE, CASS, LM-STAR	“	4	C 13
Coax 2x8 MUX 05 (or 1x4 sw 10)	IFTE, CASS, LM-STAR	“	4	C 14
Coax 2x8 MUX 05 (or 1x4 sw 10)	IFTE, CASS, LM-STAR	“	4	C 15
Coax 2x8 MUX 06 (or 1x4 sw 11)	IFTE, CASS, LM-STAR, RAF	“	21,22	A 1
Coax 2x8 MUX 06 (or 1x4 sw 11)	IFTE, CASS, LM-STAR, RAF	“	21,22	A 2
Coax 2x8 MUX 06 (or 1x4 sw 11)	IFTE, CASS, LM-STAR, RAF	“	21,22	A 3
Coax 2x8 MUX 06 (or 1x4 sw 11)	IFTE, CASS, LM-STAR	“	21,22	A 4
Coax 2x8 MUX 06 (or 1x4 sw 11)	IFTE, CASS, LM-STAR	“	21,22	A 5
Coax 2x8 MUX 06 (or 1x4 sw 12)	IFTE, CASS, LM-STAR, RAF	“	21,22	A 6
Coax 2x8 MUX 06 (or 1x4 sw 12)	IFTE, CASS, LM-STAR, RAF	“	21,22	A 7
Coax 2x8 MUX 06 (or 1x4 sw 12)	IFTE, CASS, LM-STAR, RAF	“	21,22	A 8
Coax 2x8 MUX 06 (or 1x4 sw 12)	IFTE, CASS, LM-STAR	“	21,22	A 9
Coax 2x8 MUX 06 (or 1x4 sw 12)	IFTE, CASS, LM-STAR	“	21,22	A 10
Coax 2x8 MUX 07 (or 1x4 sw 13)	IFTE, CASS, LM-STAR, RAF	“	21,22	B 1
Coax 2x8 MUX 07 (or 1x4 sw 13)	IFTE, CASS, LM-STAR, RAF	“	21,22	B 2

**Table A.38—Coax 1x4 switch (continued)**

CTI name	Legacy systems	Recommended attributes	Slot	Pin
Coax 2x8 MUX 07 (or 1x4 sw 13)	IFTE, CASS, LM-STAR, RAF	“	21,22	B 3
Coax 2x8 MUX 07 (or 1x4 sw 13)	IFTE, CASS, LM-STAR	“	21,22	B 4
Coax 2x8 MUX 07 (or 1x4 sw 13)	IFTE, CASS, LM-STAR	“	21,22	B 5
Coax 2x8 MUX 07 (or 1x4 sw 14)	IFTE, CASS, LM-STAR, RAF	“	21,22	B 6
Coax 2x8 MUX 07 (or 1x4 sw 14)	IFTE, CASS, LM-STAR, RAF	“	21,22	B 7
Coax 2x8 MUX 07 (or 1x4 sw 14)	IFTE, CASS, LM-STAR, RAF	“	21,22	B 8
Coax 2x8 MUX 07 (or 1x4 sw 14)	IFTE, CASS, LM-STAR	“	21,22	B 9
Coax 2x8 MUX 07 (or 1x4 sw 14)	IFTE, CASS, LM-STAR	“	21,22	B 10
Coax 2x8 MUX 08 (or 1x4 sw 15)	IFTE, CASS, LM-STAR, RAF	“	21,22	C 1
Coax 2x8 MUX 08 (or 1x4 sw 15)	IFTE, CASS, LM-STAR, RAF	“	21,22	C 2
Coax 2x8 MUX 08 (or 1x4 sw 15)	IFTE, CASS, LM-STAR, RAF	“	21,22	C 3
Coax 2x8 MUX 08 (or 1x4 sw 15)	IFTE, CASS, LM-STAR,	“	21,22	C 4
Coax 2x8 MUX 08 (or 1x4 sw 15)	IFTE, CASS, LM-STAR	“	21,22	C 5
Coax 2x8 MUX 08 (or 1x4 sw 16)	IFTE, CASS, LM-STAR, RAF	“	21,22	C 6
Coax 2x8 MUX 08 (or 1x4 sw 16)	IFTE, CASS, LM-STAR, RAF	“	21,22	C 7
Coax 2x8 MUX 08 (or 1x4 sw 16)	IFTE, CASS, LM-STAR, RAF	“	21,22	C 8
Coax 2x8 MUX 08 (or 1x4 sw 16)	IFTE, CASS, LM-STAR,	“	21,22	C 9
Coax 2x8 MUX 08 (or 1x4 sw 16)	IFTE, CASS, LM-STAR,	“	21,22	C 10
Coax 2x8 MUX 09 (or 1x4 sw 17)	IFTE, CASS, LM-STAR,	“	21,22	D 1
Coax 2x8 MUX 09 (or 1x4 sw 17)	IFTE, CASS, LM-STAR,	“	21,22	D 2
Coax 2x8 MUX 09 (or 1x4 sw 17)	IFTE, CASS, LM-STAR,	“	21,22	D 3
Coax 2x8 MUX 09 (or 1x4 sw 17)	IFTE, CASS, LM-STAR,	“	21,22	D 4
Coax 2x8 MUX 09 (or 1x4 sw 17)	IFTE, CASS, LM-STAR,	“	21,22	D 5
Coax 2x8 MUX 09 (or 1x4 sw 18)	IFTE, CASS, LM-STAR,	“	21,22	D 6
Coax 2x8 MUX 09 (or 1x4 sw 18)	IFTE, CASS, LM-STAR,	“	21,22	D 7
Coax 2x8 MUX 09 (or 1x4 sw 18)	IFTE, CASS, LM-STAR,	“	21,22	D 8
Coax 2x8 MUX 09 (or 1x4 sw 18)	IFTE, CASS, LM-STAR,	“	21,22	D 9

**Table A.38—Coax 1x4 switch (continued)**

CTI name	Legacy systems	Recommended attributes	Slot	Pin
Coax 2x8 MUX 09 (or 1x4 sw 18)	IFTE, CASS, LM-STAR,	“	21,22	D 10
Coax 2x8 MUX 10 (or 1x4 sw 19)	IFTE, CASS, LM-STAR, RAF	“	21,22	E 1
Coax 2x8 MUX 10 (or 1x4 sw 19)	IFTE, CASS, LM-STAR, RAF	“	21,22	E 2
Coax 2x8 MUX 10 (or 1x4 sw 19)	IFTE, CASS, LM-STAR, RAF	“	21,22	E 3
Coax 2x8 MUX 10 (or 1x4 sw 19)	IFTE, CASS, LM-STAR,	“	21,22	E 4
Coax 2x8 MUX 10 (or 1x4 sw 19)	IFTE, CASS, LM-STAR,	“	21,22	E 5
Coax 2x8 MUX 10 (or 1x4 sw 20)	IFTE, CASS, LM-STAR,	“	21,22	E 6
Coax 2x8 MUX 10 (or 1x4 sw 20)	IFTE, CASS, LM-STAR,	“	21,22	E 7
Coax 2x8 MUX 10 (or 1x4 sw 20)	IFTE, CASS, LM-STAR,	“	21,22	E 8
Coax 2x8 MUX 10 (or 1x4 sw 20)	IFTE, CASS, LM-STAR,	“	21,22	E 9
Coax 2x8 MUX 10 (or 1x4 sw 20)	IFTE, CASS, LM-STAR,	“	21,22	E 10
Coax 2x8 MUX 11 (or 1x4 sw 21)	IFTE, CASS, LM-STAR, RAF	“	21,22	F 1
Coax 2x8 MUX 11 (or 1x4 sw 21)	IFTE, CASS, LM-STAR, RAF	“	21,22	F 2
Coax 2x8 MUX 11 (or 1x4 sw 21)	IFTE, CASS, LM-STAR, RAF	“	21,22	F 3
Coax 2x8 MUX 11 (or 1x4 sw 21)	IFTE, CASS, LM-STAR,	“	21,22	F 4
Coax 2x8 MUX 11 (or 1x4 sw 21)	IFTE, CASS, LM-STAR,	“	21,22	F 5
Coax 2x8 MUX 11 (or 1x4 sw 22)	IFTE, CASS, LM-STAR, RAF	“	21,22	F 6
Coax 2x8 MUX 11 (or 1x4 sw 22)	IFTE, CASS, LM-STAR, RAF	“	21,22	F 7
Coax 2x8 MUX 11 (or 1x4 sw 22)	IFTE, CASS, LM-STAR, RAF	“	21,22	F 8
Coax 2x8 MUX 11 (or 1x4 sw 22)	IFTE, CASS, LM-STAR,	“	21,22	F 9
Coax 2x8 MUX 11 (or 1x4 sw 22)	IFTE, CASS, LM-STAR,	“	21,22	F 10
Coax 2x8 MUX 12 (or 1x4 sw 23)	IFTE, CASS, LM-STAR, RAF	“	21,22	G 1
Coax 2x8 MUX 12 (or 1x4 sw 23)	IFTE, CASS, LM-STAR, RAF	“	21,22	G 2
Coax 2x8 MUX 12 (or 1x4 sw 23)	IFTE, CASS, LM-STAR, RAF	“	21,22	G 3
Coax 2x8 MUX 12 (or 1x4 sw 23)	IFTE, CASS, LM-STAR,	“	21,22	G 4
Coax 2x8 MUX 12 (or 1x4 sw 23)	IFTE, CASS, LM-STAR,	“	21,22	G 5
Coax 2x8 MUX 12 (or 1x4 sw 24)	IFTE, CASS, LM-STAR, RAF	“	21,22	G 6

**Table A.38—Coax 1x4 switch (continued)**

CTI name	Legacy systems	Recommended attributes	Slot	Pin
Coax 2x8 MUX 12 (or 1x4 sw 24)	IFTE, CASS, LM-STAR, RAF	“	21,22	G 7
Coax 2x8 MUX 12 (or 1x4 sw 24)	IFTE, CASS, LM-STAR, RAF	“	21,22	G 8
Coax 2x8 MUX 12 (or 1x4 sw 24)	IFTE, CASS, LM-STAR,	“	21,22	G 9
Coax 2x8 MUX 12 (or 1x4 sw 24)	IFTE, CASS, LM-STAR,	“	21,22	G 10
Coax 2x8 MUX 13 (or 1x4 sw 25)	IFTE, CASS, LM-STAR, RAF	“	21,22	H 1
Coax 2x8 MUX 13 (or 1x4 sw 25)	IFTE, CASS, LM-STAR, RAF	“	21,22	H 2
Coax 2x8 MUX 13 (or 1x4 sw 25)	IFTE, CASS, LM-STAR, RAF	“	21,22	H 3
Coax 2x8 MUX 13 (or 1x4 sw 25)	IFTE, CASS, LM-STAR,	“	21,22	H 4
Coax 2x8 MUX 13 (or 1x4 sw 25)	IFTE, CASS, LM-STAR,	“	21,22	H 5
Coax 2x8 MUX 13 (or 1x4 sw 26)	IFTE, CASS, LM-STAR, RAF	“	21,22	H 6
Coax 2x8 MUX 13 (or 1x4 sw 26)	IFTE, CASS, LM-STAR, RAF	“	21,22	H 7
Coax 2x8 MUX 13 (or 1x4 sw 26)	IFTE, CASS, LM-STAR, RAF	“	21,22	H 8
Coax 2x8 MUX 13 (or 1x4 sw 26)	IFTE, CASS, LM-STAR,	“	21,22	H 9
Coax 2x8 MUX 13 (or 1x4 sw 26)	IFTE, CASS, LM-STAR,	“	21,22	H 10
Coax 2x8 MUX 14 (or 1x4 sw 27)	IFTE, CASS, LM-STAR, RAF	“	23,24	A 1
Coax 2x8 MUX 14 (or 1x4 sw 27)	IFTE, CASS, LM-STAR, RAF	“	23,24	A 2
Coax 2x8 MUX 14 (or 1x4 sw 27)	IFTE, CASS, LM-STAR, RAF	“	23,24	A 3
Coax 2x8 MUX 14 (or 1x4 sw 27)	IFTE, CASS, LM-STAR,	“	23,24	A 4
Coax 2x8 MUX 14 (or 1x4 sw 27)	IFTE, CASS, LM-STAR,	“	23,24	A 5
Coax 2x8 MUX 14 (or 1x4 sw 28)	IFTE, CASS, LM-STAR, RAF	“	23,24	A 6
Coax 2x8 MUX 14 (or 1x4 sw 28)	IFTE, CASS, LM-STAR, RAF	“	23,24	A 7
Coax 2x8 MUX 14 (or 1x4 sw 28)	IFTE, CASS, LM-STAR, RAF	“	23,24	A 8
Coax 2x8 MUX 14 (or 1x4 sw 28)	IFTE, CASS, LM-STAR,	“	23,24	A 9
Coax 2x8 MUX 15 (or 1x4 sw 29)	IFTE, CASS, LM-STAR,	“	23,24	A 10
Coax 2x8 MUX 15 (or 1x4 sw 29)	IFTE, CASS, LM-STAR, RAF	“	23,24	A 11
Coax 2x8 MUX 15 (or 1x4 sw 29)	IFTE, CASS, LM-STAR, RAF	“	23,24	A 12
Coax 2x8 MUX 15 (or 1x4 sw 29)	IFTE, CASS, LM-STAR, RAF	“	23,24	A 13

**Table A.38—Coax 1x4 switch (continued)**

CTI name	Legacy systems	Recommended attributes	Slot	Pin
Coax 2x8 MUX 15 (or 1x4 sw 29)	IFTE, CASS, LM-STAR,	“	23,24	A 14
Coax 2x8 MUX 15 (or 1x4 sw 30)	IFTE, CASS, LM-STAR,	“	23,24	A 15
Coax 2x8 MUX 15 (or 1x4 sw 30)	CASS, LM-STAR	“	23,24	B 1
Coax 2x8 MUX 15 (or 1x4 sw 30)	IFTE, CASS, LM-STAR,	“	23,24	B 2
Coax 2x8 MUX 15 (or 1x4 sw 30)	IFTE, CASS, LM-STAR,	“	23,24	B 3
Coax 2x8 MUX 15 (or 1x4 sw 30)	IFTE, CASS, LM-STAR,	“	23,24	B 4
Coax 2x8 MUX 16 (or 1x4 sw 31)	IFTE, CASS, LM-STAR,	“	23,24	B 5
Coax 2x8 MUX 16 (or 1x4 sw 31)	CASS, LM-STAR, RAF	“	23,24	B 6
Coax 2x8 MUX 16 (or 1x4 sw 31)	IFTE, CASS, LM-STAR, RAF	“	23,24	B 7
Coax 2x8 MUX 16 (or 1x4 sw 31)	IFTE, CASS, LM-STAR, RAF	“	23,24	B 8
Coax 2x8 MUX 16 (or 1x4 sw 31)	IFTE, CASS, LM-STAR	“	23,24	B 9
Coax 2x8 MUX 16 (or 1x4 sw 32)	IFTE, CASS, LM-STAR	“	23,24	B 10
Coax 2x8 MUX 16 (or 1x4 sw 32)	CASS, LM-STAR, RAF	“	23,24	B 11
Coax 2x8 MUX 16 (or 1x4 sw 32)	IFTE, CASS, LM-STAR, RAF	“	23,24	B 12
Coax 2x8 MUX 16 (or 1x4 sw 32)	IFTE, CASS, LM-STAR, RAF	“	23,24	B 13
Coax 2x8 MUX 16 (or 1x4 sw 32)	IFTE, CASS, LM-STAR	“	23,24	B 14
Coax 2x8 MUX 17 (or 1x4 sw 33)	IFTE, CASS, LM-STAR	“	23,24	B 15
Coax 2x8 MUX 17 (or 1x4 sw 33)	CASS, LM-STAR, RAF	“	23,24	C 1
Coax 2x8 MUX 17 (or 1x4 sw 33)	IFTE, CASS, LM-STAR, RAF	“	23,24	C 2
Coax 2x8 MUX 17 (or 1x4 sw 33)	IFTE, CASS, LM-STAR, RAF	“	23,24	C 3
Coax 2x8 MUX 17 (or 1x4 sw 33)	IFTE, CASS, LM-STAR	“	23,24	C 4
Coax 2x8 MUX 17 (or 1x4 sw 34)	IFTE, CASS, LM-STAR	“	23,24	C 5
Coax 2x8 MUX 17 (or 1x4 sw 34)	CASS, LM-STAR, RAF	“	23,24	C 6
Coax 2x8 MUX 17 (or 1x4 sw 34)	IFTE, CASS, LM-STAR, RAF	“	23,24	C 7
Coax 2x8 MUX 17 (or 1x4 sw 34)	IFTE, CASS, LM-STAR, RAF	“	23,24	C 8
Coax 2x8 MUX 17 (or 1x4 sw 34)	IFTE, LM-STAR	“	23,24	C 9
Coax 2x8 MUX 18 (or 1x4 sw 35)	IFTE, LM-STAR	“	23,24	C 10



**Table A.38—Coax 1x4 switch (continued)**

CTI name	Legacy systems	Recommended attributes	Slot	Pin
Coax 2x8 MUX 18 (or 1x4 sw 35)	CASS, LM-STAR, RAF	“	23,24	C 11
Coax 2x8 MUX 18 (or 1x4 sw 35)	IFTE, CASS, LM-STAR, RAF	“	23,24	C 12
Coax 2x8 MUX 18 (or 1x4 sw 35)	IFTE, CASS, LM-STAR, RAF	“	23,24	C 13
Coax 2x8 MUX 18 (or 1x4 sw 35)	IFTE, LM-STAR	“	23,24	C 14
Coax 2x8 MUX 18 (or 1x4 sw 36)	IFTE, LM-STAR	“	23,24	C 15
Coax 2x8 MUX 18 (or 1x4 sw 36)	CASS, LM-STAR, RAF	“	23,24	D 1
Coax 2x8 MUX 18 (or 1x4 sw 36)	IFTE, CASS, LM-STAR, RAF	“	23,24	D 2
Coax 2x8 MUX 18 (or 1x4 sw 36)	IFTE, CASS, LM-STAR, RAF	“	23,24	D 3
Coax 2x8 MUX 18 (or 1x4 sw 36)	IFTE, LM-STAR	“	23,24	D 4
Coax 2x8 MUX 19 (or 1x4 sw 37)	IFTE, LM-STAR	“	23,24	D 5
Coax 2x8 MUX 19 (or 1x4 sw 37)	CASS, LM-STAR, RAF	“	23,24	D 6
Coax 2x8 MUX 19 (or 1x4 sw 37)	IFTE, CASS, LM-STAR, RAF	“	23,24	D 7
Coax 2x8 MUX 19 (or 1x4 sw 37)	IFTE, CASS, LM-STAR, RAF	“	23,24	D 8
Coax 2x8 MUX 19 (or 1x4 sw 37)	IFTE, LM-STAR	“	23,24	D 9
Coax 2x8 MUX 19 (or 1x4 sw 38)	IFTE, LM-STAR	“	23,24	D 10
Coax 2x8 MUX 19 (or 1x4 sw 38)	IFTE, CASS, LM-STAR, RAF	“	23,24	D 11
Coax 2x8 MUX 19 (or 1x4 sw 38)	IFTE, CASS, LM-STAR, RAF	“	23,24	D 12
Coax 2x8 MUX 19 (or 1x4 sw 38)	IFTE, CASS, LM-STAR, RAF	“	23,24	D 13
Coax 2x8 MUX 19 (or 1x4 sw 38)	IFTE, LM-STAR	“	23,24	D 14
Coax 2x8 MUX 20 (or 1x4 sw 39)	IFTE, LM-STAR	“	23,24	D 15
Coax 2x8 MUX 20 (or 1x4 sw 39)	IFTE, CASS, LM-STAR, RAF	“	23,24	E 1
Coax 2x8 MUX 20 (or 1x4 sw 39)	IFTE, CASS, LM-STAR, RAF	“	23,24	E 2
Coax 2x8 MUX 20 (or 1x4 sw 39)	IFTE, CASS, LM-STAR, RAF	“	23,24	E 3
Coax 2x8 MUX 20 (or 1x4 sw 39)	IFTE, LM-STAR	“	23,24	E 4
Coax 2x8 MUX 20 (or 1x4 sw 40)	IFTE, LM-STAR	“	23,24	E 5
Coax 2x8 MUX 20 (or 1x4 sw 40)	CASS, LM-STAR	“	23,24	E 6
Coax 2x8 MUX 20 (or 1x4 sw 40)	IFTE, CASS, LM-STAR, RAF	“	23,24	E 7

**Table A.38—Coax 1x4 switch (continued)**

CTI name	Legacy systems	Recommended attributes	Slot	Pin
Coax 2x8 MUX 20 (or 1x4 sw 40)	IFTE, CASS, LM-STAR, RAF	“	23,24	E 8
Coax 2x8 MUX 20 (or 1x4 sw 40)	IFTE, LM-STAR, RAF	“	23,24	E 9
Coax 2x8 MUX 21 (or 1x4 sw 41)	IFTE, LM-STAR, RAF	“	23,24	E 10
Coax 2x8 MUX 21 (or 1x4 sw 41)	IFTE, CASS	“	23,24	E 11
Coax 2x8 MUX 21 (or 1x4 sw 41)	IFTE, CASS	“	23,24	E 12
Coax 2x8 MUX 21 (or 1x4 sw 41)	IFTE, CASS	“	23,24	E 13
Coax 2x8 MUX 21 (or 1x4 sw 41)	IFTE	“	23,24	E 14
Coax 2x8 MUX 21 (or 1x4 sw 42)	IFTE	“	23,24	E 15
Coax 2x8 MUX 21 (or 1x4 sw 42)	IFTE, CASS	“	23,24	F 1
Coax 2x8 MUX 21 (or 1x4 sw 42)	IFTE, CASS	“	23,24	F 2
Coax 2x8 MUX 21 (or 1x4 sw 42)	IFTE, CASS	“	23,24	F 3
Coax 2x8 MUX 21 (or 1x4 sw 42)	IFTE	“	23,24	F 4
Coax 2x8 MUX 15 (or 1x4 sw 29)	IFTE	“	23,24	F 5
Coax 2x8 MUX 22 (or 1x4 sw 43)	IFTE	“	23,24	F 6
Coax 2x8 MUX 22 (or 1x4 sw 43)	IFTE	“	23,24	F 7
Coax 2x8 MUX 22 (or 1x4 sw 43)	IFTE	“	23,24	F 8
Coax 2x8 MUX 22 (or 1x4 sw 43)	IFTE	“	23,24	F 9
Coax 2x8 MUX 22 (or 1x4 sw 43)	IFTE	“	23,24	F 10
Coax 2x8 MUX 22 (or 1x4 sw 44)	IFTE	“	23,24	F 11
Coax 2x8 MUX 22 (or 1x4 sw 44)	IFTE	“	23,24	F 12
Coax 2x8 MUX 22 (or 1x4 sw 44)	IFTE	“	23,24	F 13
Coax 2x8 MUX 22 (or 1x4 sw 44)	IFTE	“	23,24	F 14
Coax 2x8 MUX 22 (or 1x4 sw 44)	IFTE	“	23,24	F 15
Coax 2x8 MUX 23 (or 1x4 sw 45)		“	23,24	G 1
Coax 2x8 MUX 23 (or 1x4 sw 45)	IFTE	“	23,24	G 2
Coax 2x8 MUX 23 (or 1x4 sw 45)	IFTE	“	23,24	G 3
Coax 2x8 MUX 23 (or 1x4 sw 45)	IFTE	“	23,24	G 4

**Table A.38—Coax 1x4 switch (continued)**

CTI name	Legacy systems	Recommended attributes	Slot	Pin
Coax 2x8 MUX 23 (or 1x4 sw 45)	IFTE	“	23,24	G 5
Coax 2x8 MUX 23 (or 1x4 sw 46)		“	23,24	G 6
Coax 2x8 MUX 23 (or 1x4 sw 46)	IFTE	“	23,24	G 7
Coax 2x8 MUX 23 (or 1x4 sw 46)	IFTE	“	23,24	G 8
Coax 2x8 MUX 23 (or 1x4 sw 46)	IFTE	“	23,24	G 9
Coax 2x8 MUX 23 (or 1x4 sw 46)	IFTE	“	23,24	G 10
Coax 2x8 MUX 24 (or 1x4 sw 47)		“	23,24	H 1
Coax 2x8 MUX 24 (or 1x4 sw 47)	IFTE	“	23,24	H 2
Coax 2x8 MUX 24 (or 1x4 sw 47)	IFTE	“	23,24	H 3
Coax 2x8 MUX 24 (or 1x4 sw 47)	IFTE	“	23,24	H 4
Coax 2x8 MUX 24 (or 1x4 sw 47)	IFTE	“	23,24	H 5
Coax 2x8 MUX 24 (or 1x4 sw 48)		“	23,24	H 6
Coax 2x8 MUX 24 (or 1x4 sw 48)	IFTE	“	23,24	H 7
Coax 2x8 MUX 24 (or 1x4 sw 48)	IFTE	“	23,24	H 8
Coax 2x8 MUX 24 (or 1x4 sw 48)	IFTE	“	23,24	H 9
Coax 2x8 MUX 24 (or 1x4 sw 48)	IFTE	“	23,24	H10

NOTE—Capacitance measured at the CTI, which includes CSW, internal cabling, and switch capacitance, shall not exceeded 100 pF.

**Table A.39—1x2 coax switch**

CTI name	Legacy systems	Recommended attributes	Slot	Pin
	LM-STAR, C17	Impedance: 50 Ω Freq range: dc to 1 GHz Max power: 2 W Max Capacitance: 15 pF VSWR max: (@ 1 GHz): 1.15+0.01f(GHz) RF leakage: -60 db @ 1 GHz Bandwidth: 100 MHz to 1.2 GHz Path resistance: <2 Ω @ 1 mA		
1x2 CSW 1 Common			21,22	F 11
1x2 CSW 1 Port1	“	“	21,22	F 12
1x2 CSW 1 Port2	“	“	21,22	F 13
1x2 CSW 2 Common	“	“	21,22	F 14
1x2 CSW 2 Port1	“	“	21,22	F 15
1x2 CSW 2 Port2	“	“	21,22	F 16
1x2 CSW 3 Common	“	“	21,22	F 17
1x2 CSW 3 Port1	“	“	21,22	F 18
1x2 CSW 3 Port2	“	“	21,22	F 19
1x2 CSW 4 Common	“	“	21,22	G 11
1x2 CSW 4 Port1	“	“	21,22	G 12
1x2 CSW 4 Port2	“	“	21,22	G 13
1x2 CSW 5 Common	“	“	21,22	G 14
1x2 CSW 5 Port1	“	“	21,22	G 15
1x2 CSW 5 Port2	“	“	21,22	G 16
1x2 CSW 6 Common	“	“	21,22	G 17
1x2 CSW 6 Port1	“	“	21,22	G 18
1x2 CSW 6 Port2	“	“	21,22	G 19
1x2 CSW 7 Common	LM-STAR	“	21,22	H 11
1x2 CSW 7 Port1	“	“	21,22	H 12
1x2 CSW 7 Port2	“	“	21,22	H 13
1x2 CSW 8 Common	“	“	21,22	H 14
1x2 CSW 8 Port1	“	“	21,22	H 15
1x2 CSW 8 Port2	“	“	21,22	H 16
1x2 CSW 9 Common	“	“	21,22	H 17
1x2 CSW 9 Port1	“	“	21,22	H 18
1x2 CSW 9 Port2	“	“	21,22	H 19
NOTE—Capacitance measured at the CTI, which includes CSW, internal cabling, and switch capacitance, shall not exceed 100 pF.				

Table A.40—1x4 power switch

CTI name	Legacy systems	Recommended attributes	Slot	Pin
1x4 PSW1 Common	CASS, LM-STAR, IAIS	Max voltage: 300 V Max current: 18.75 A Switch impedance: <20 mΩ @ max current Freq. range: dc to 1 kHz Breakdown voltage: 1 kV	1,2	A 6
1x4 PSW1 Port1	“	“	1,2	A 7
1x4 PSW1 Port2	“	“	1,2	A 8
1x4 PSW1 Port3	“	“	1,2	A 9
1x4 PSW1 Port4	“	“	1,2	A 10
1x4 PSW2 Common	“	“	1,2	A 11
1x4 PSW2 Port1	“	“	1,2	A 12
1x4 PSW2 Port2	“	“	1,2	A 13
1x4 PSW2 Port3	“	“	1,2	A 14
1x4 PSW2 Port4	“	“	1,2	A 15
1x4 PSW3 Common	“	“	1,2	B 6
1x4 PSW3 Port1	“	“	1,2	B 7
1x4 PSW3 Port2	“	“	1,2	B 8
1x4 PSW3 Port3	“	“	1,2	B 9
1x4 PSW3 Port4	“	“	1,2	B 10
1x4 PSW4 Common	“	“	1,2	B 11
1x4 PSW4 Port1	“	“	1,2	B 12
1x4 PSW4 Port2	“	“	1,2	B 13
1x4 PSW4 Port3	“	“	1,2	B 14
1x4 PSW4 Port4	“	“	1,2	B 15
1x4 PSW5 Common	“	“	1,2	C 11
1x4 PSW5 Port1	“	“	1,2	C 12
1x4 PSW5 Port2	“	“	1,2	C 13
1x4 PSW5 Port3	“	“	1,2	C 14
1x4 PSW5 Port4	“	“	1,2	C 15
1x4 PSW6 Common	IAIS	Max voltage: 300 V Max current: 20 A Switch impedance: <100 mΩ @ max current Freq. range: dc to 1 kHz Breakdown voltage: 1 kV	1,2	D 11
1x4 PSW6 Port1	“	“	1,2	D 12
1x4 PSW6 Port2	“	“	1,2	D 13
1x4 PSW6 Port3	“	“	1,2	D 14
1x4 PSW6 Port4	“	“	1,2	D 15

**Table A.41—1x2 power switch**

CTI name	Legacy systems	Recommended attributes	Slot	Pin
1x2 PSW 1 Common	LM-STAR, C17	Max voltage: 220 Vac/dc Max current: 10 A Switch path resistance: <100 mΩ @ max current Freq. range: dc to 1 kHz Breakdown voltage: 1 kV	1,2	E 1
1x2 PSW 1 Port1	“	“	1,2	E 2
1x2 PSW 1 Port2	“	“	1,2	E 3
1x2 PSW 2 Common	“	“	1,2	F 1
1x2 PSW 2 Port1	“	“	1,2	F 2
1x2 PSW 2 Port2	“	“	1,2	F 3
1x2 PSW 3 Common	“	“	1,2	F 4
1x2 PSW 3 Port1	“	“	1,2	F 5
1x2 PSW 3 Port2	“	“	1,2	F 6
1x2 PSW 4 Common	CASS, LM-STAR, C17	Max voltage: 300 V Max current: 20 A Switch path Resistance: <20 mΩ @ max current Freq. range: dc to 1 kHz Breakdown voltage: 1 kV	1,2	F 7
1x2 PSW 4 Port1	“	“	1,2	F 8
1x2 PSW 4 Port2	“	“	1,2	F 9
1x2 PSW 5 Common	IFTE, LM-STAR, TETS, C17, RAF	Max voltage: 220 Vac/dc Max current: 10 A Switch path resistance: <100 mΩ @ max current Freq. range: dc to 1 kHz Breakdown voltage: 1 kV	1,2	F 10
1x2 PSW 5 Port1	“	“	1,2	F 11
1x2 PSW 5 Port2	LM-STAR, C17	“	1,2	F 12
1x2 PSW 6 Common	IFTE, LM-STAR, TETS, C17	“	1,2	F 13
1x2 PSW 6 Port1	“	“	1,2	F 14
1x2 PSW 6 Port2	LM-STAR, C17	“	1,2	F 15
1x2 PSW 7 Common	IFTE, LM-STAR, TETS, C17, RAF	“	1,2	G 1
1x2 PSW 7 Port1	“	“	1,2	G 2
1x2 PSW 7 Port2	LM-STAR, C17	“	1,2	G 3
1x2 PSW 8 Common	IFTE, LM-STAR, TETS, C17, RAF	“	1,2	G 4
1x2 PSW 8 Port1	“	“	1,2	G 5
1x2 PSW 8 Port2	LM-STAR, C17	“	1,2	G 6
1x2 PSW 9 Common	IFTE, LM-STAR, TETS, C17	“	1,2	G 7
1x2 PSW 9 Port1	“	“	1,2	G 8
1x2 PSW 9 Port2	LM-STAR, C17	“	1,2	G 9
1x2 PSW 10 Common	IFTE, LM-STAR, TETS, C17	“	1,2	G 10
1x2 PSW 10 Port1	“	“	1,2	G 11
1x2 PSW 10 Port2	LM-STAR, C17	“	1,2	G 12
1x2 PSW 11 Common	LM-STAR, TETS, C17	“	1,2	G 13
1x2 PSW 11 Port1	“	“	1,2	G 14
1x2 PSW 11 Port2	LM-STAR, C17	“	1,2	G 15

Table A.41—1x2 power switch (continued)

CTI name	Legacy systems	Recommended attributes	Slot	Pin
1x2 PSW 12 Common	LM-STAR, TETS, C17	“	1,2	H 1
1x2 PSW 12 Port1	“	“	1,2	H 2
1x2 PSW 12 Port2	LM-STAR, C17	“	1,2	H 3
1x2 PSW 13 Common	“	“	1,2	H 4
1x2 PSW 13 Port1	“	“	1,2	H 5
1x2 PSW 13 Port2	“	“	1,2	H 6
1x2 PSW 14 Common	None	“	1,2	H 7
1x2 PSW 14 Port1	None	“	1,2	H 8
1x2 PSW 14 Port2	None	“	1,2	H 9
1x2 PSW 15 Common	None	“	1,2	H 10
1x2 PSW 15 Port1	None	“	1,2	H 11
1x2 PSW 15 Port2	None	“	1,2	H 12
1x2 PSW 16 Common	None	“	1,2	H 13
1x2 PSW 16 Port1	None	“	1,2	H 14
1x2 PSW 16 Port2	None	“	1,2	H 15
1x2 PSW 17 Common	IFTE, CASS, LM-STAR	Max voltage: 300 V Max current: 10 A Switch path resistance: <40 mΩ @ max current Freq. range: dc to 1 kHz Breakdown voltage: 1 kV	29	A 1
1x2 PSW 17 Port1	“	“	29	A 2
1x2 PSW 17 Port2	CASS, LM-STAR	“	29	A 3
1x2 PSW 18 Common	IFTE, CASS, LM- STAR	“	29	A 4
1x2 PSW 18 Port1	“	“	29	A 5
1x2 PSW 18 Port2	CASS, LM-STAR	“	29	A 6
1x2 PSW 19 Common	IFTE, CASS, LM- STAR	“	29	A 7
1x2 PSW 19 Port1	“	“	29	A 8
1x2 PSW 19 Port2	CASS, LM-STAR	“	29	A 9
1x2 PSW 20 Common	IFTE, CASS, LM- STAR	“	29	A 10
1x2 PSW 20 Port1	“	“	29	A 11
1x2 PSW 20 Port2	CASS, LM-STAR	“	29	A 12
1x2 PSW 21 Common	IFTE, CASS, LM- STAR	“	29	B 1
1x2 PSW 21 Port1	“	“	29	B 2
1x2 PSW 21 Port2	CASS, LM-STAR	“	29	B 3
1x2 PSW 22 Common	IFTE, CASS, LM- STAR	“	29	B 4
1x2 PSW 22 Port1	“	“	29	B 5
1x2 PSW 22 Port2	CASS, LM-STAR	“	29	B 6
1x2 PSW 23 Common	IFTE, CASS, LM- STAR	“	29	B 7
1x2 PSW 23 Port1	“	“	29	B 8
1x2 PSW 23 Port2	CASS, LM-STAR	“	29	B 9
1x2 PSW 24 Common	IFTE, CASS, LM- STAR	“	29	B 10
1x2 PSW 24 Port1	“	“	29	B 11
1x2 PSW 24 Port2	CASS, LM-STAR	“	29	B 12
1x2 PSW 25 Common	IFTE, CASS	“	29	C 1
1x2 PSW 25 Port1	“	“	29	C 2
1x2 PSW 25 Port2	CASS	“	29	C 3

**Table A.41—1x2 power switch (continued)**

CTI name	Legacy systems	Recommended attributes	Slot	Pin
1x2 PSW 26 Common	IFTE, CASS, C17	“	29	C 4
1x2 PSW 26 Port1	“	“	29	C 5
1x2 PSW 26 Port2	CASS, C17	“	29	C 6
1x2 PSW 27 Common	IFTE, CASS, C17	“	29	C 7
1x2 PSW 27 Port1	“	“	29	C 8
1x2 PSW 27 Port2	CASS, C17	“	29	C 9
1x2 PSW 28 Common	IFTE, CASS, C17	“	29	C 10
1x2 PSW 28 Port1	“	“	29	C 11
1x2 PSW 28 Port2	CASS, C17	“	29	C 12

**Table A.42—DPDT power switch**

CTI name	Legacy systems	Recommended attributes	Slot	Pin
	CASS	Max voltage: 300 V Max current: 20 A Switch impedance: <20 mΩ @ max current Freq. range: dc to 1 kHz Breakdown voltage: 1 kV		
2x2 PSW 1 Common			29	A 13
2x2 PSW 1 Port1NC	“	“	29	B 13
2x2 PSW 1 Port1NO	“	“	29	C 13
2x2 PSW 1 Common	“	“	29	A 14
2x2 PSW 1 Port2NC	“	“	29	B 14
2x2 PSW 1 Port2NO	“	“	29	C 14
2x2 PSW 2 Common	“	“	29	A 15
2x2 PSW 2 Port1NC	“	“	29	B 15
2x2 PSW 2 Port1NO	“	“	29	C 15
2x2 PSW 2 Common	“	“	29	A 16
2x2 PSW 2 Port2NC	“	“	29	B 16
2x2 PSW 2 Port2NO	“	“	29	C 16



**Table A.43—1x1 power switch**

CTI name	Legacy systems	Recommended attributes	Slot	Pin
1x1 PSW1 Common	CASS, TETS, C17, RAF	Max voltage: 220 Vac/dc Max current: 10 A Switch path resistance: <100 mΩ @ max current Freq. range: dc to 1 kHz Breakdown voltage: 1 kV	1,2	C 9
1x1 PSW1 Port1	“	“	1,2	C 10
1x1 PSW2 Common	“	“	1,2	D 9
1x1 PSW2 Port1	“	“	1,2	D 10
1x1 PSW3 Common	“	“	1,2	E 4
1x1 PSW3 Port1	“	“	1,2	E 5
1x1 PSW4 Common	“	“	1,2	E 6
1x1 PSW4 Port1	“	“	1,2	E 7
1x1 PSW5 Common	“	“	1,2	E 8
1x1 PSW5 Port1	“	“	1,2	E 9
1x1 PSW6 Common	“	“	1,2	E 10
1x1 PSW6 Port1	“	“	1,2	E 11
1x1 PSW7 Common	“	“	1,2	E 12
1x1 PSW7 Port1	“	“	1,2	E 13
1x1 PSW8 Common	“	“	1,2	E 14
1x1 PSW8 Port1	“	“	1,2	E 15
1x1 PSW9 Common	“	“	1,2	E 16
1x1 PSW9 Port1	“	“	1,2	E 17
1x1 PSW10 Common	“	“	1,2	F 16
1x1 PSW10 Port1	“	“	1,2	F 17
1x1 PSW11 Common	“	“	1,2	G 16
1x1 PSW11 Port1	“	“	1,2	G 17
1x1 PSW12 Common	“	“	1,2	H 16
1x1 PSW12 Port1	“	“	1,2	H 17

**Table A.44—1x8 switch**

CTI name	Legacy systems	Recommended attributes	Slot	Pin
Signal 1x8 Mux1 Common (+)	ESTS, TETS	Max current: 2 A Max voltage: 300 Vdc/ 300 Vac Max switching power (dc): 60 W Max switching power (ac): 125 VA Max freq: 10 MHz	15	B 14
Signal 1x8 Mux1 Common (-)	“	“	15	A 14
Signal 1x8 Mux1 Channel 1(+)	“	“	15	A 15
Signal 1x8 Mux1 Channel 1(-)	“	“	15	B 15
Signal 1x8 Mux1 Channel 2(+)	“	“	15	B 16
Signal 1x8 Mux1 Channel 2(-)	“	“	15	A 16
Signal 1x8 Mux1 Channel 3(+)	“	“	15	A 17
Signal 1x8 Mux1 Channel 3(-)	“	“	15	B 17
Signal 1x8 Mux1 Channel 4(+)	“	“	15	B 18
Signal 1x8 Mux1 Channel 4(-)	“	“	15	A 18
Signal 1x8 Mux1 Channel 5(+)	“	“	15	A 19
Signal 1x8 Mux1 Channel 5(-)	“	“	15	B 19
Signal 1x8 Mux1 Channel 6(+)	“	“	15	B 20
Signal 1x8 Mux1 Channel 6(-)	“	“	15	A 20
Signal 1x8 Mux1 Channel 7(+)	TETS	“	15	A 21
Signal 1x8 Mux1 Channel 7(-)	“	“	15	B 21
Signal 1x8 Mux1 Channel 8(+)	“	“	15	B 22
Signal 1x8 Mux1 Channel 8(-)	“	“	15	A 22
Signal 1x8 Mux2 Common (+)	ESTS, TETS	“	15	A 23
Signal 1x8 Mux2 Common (-)	“	“	15	B 23
Signal 1x8 Mux2 Channel 1(+)	“	“	15	B 24
Signal 1x8 Mux2 Channel 1(-)	“	“	15	A 24
Signal 1x8 Mux2 Channel 2(+)	“	“	15	A 25
Signal 1x8 Mux2 Channel 2(-)	“	“	15	B 25
Signal 1x8 Mux2 Channel 3(+)	“	“	15	B 26
Signal 1x8 Mux2 Channel 3(-)	“	“	15	A 26
Signal 1x8 Mux2 Channel 4(+)	“	“	15	A 27
Signal 1x8 Mux2 Channel 4(-)	“	“	15	B 27
Signal 1x8 Mux2 Channel 5(+)	“	“	15	B 28
Signal 1x8 Mux2 Channel 5(-)	“	“	15	A 28
Signal 1x8 Mux2 Channel 6(+)	“	“	15	A 29
Signal 1x8 Mux2 Channel 6(-)	“	“	15	B 29
Signal 1x8 Mux2 Channel 7(+)	TETS	“	15	B 30
Signal 1x8 Mux2 Channel 7(-)	“	“	15	A 30
Signal 1x8 Mux2 Channel 8(+)	“	“	15	A 31
Signal 1x8 Mux2 Channel 8(-)	“	“	15	B 31
Signal 1x8 Mux3 Common (+)	ESTS, TETS	“	15	B 32
Signal 1x8 Mux3 Common (-)	“	“	15	A 32
Signal 1x8 Mux3 Channel 1(+)	“	“	15	A 33
Signal 1x8 Mux3 Channel 1(-)	“	“	15	B 33
Signal 1x8 Mux3 Channel 2(+)	“	“	15	B 34
Signal 1x8 Mux3 Channel 2(-)	“	“	15	A 34
Signal 1x8 Mux3 Channel 3(+)	“	“	15	A 35
Signal 1x8 Mux3 Channel 3(-)	“	“	15	B 35
Signal 1x8 Mux3 Channel 4(+)	“	“	15	B 36
Signal 1x8 Mux3 Channel 4(-)	“	“	15	A 36
Signal 1x8 Mux3 Channel 5(+)	“	“	15	A 37

Table A.44—1x8 switch (continued)

CTI name	Legacy systems	Recommended attributes	Slot	Pin
Signal 1x8 Mux3 Channel 5(-)	“	“	15	B 37
Signal 1x8 Mux3 Channel 6(+)	“	“	15	B 38
Signal 1x8 Mux3 Channel 6(-)	“	“	15	A 38
Signal 1x8 Mux3 Channel 7(+)	TETS	“	15	A 39
Signal 1x8 Mux3 Channel 7(-)	“	“	15	B 39
Signal 1x8 Mux3 Channel 8(+)	“	“	15	B 40
Signal 1x8 Mux3 Channel 8(-)	“	“	15	A 40
Signal 1x8 Mux4 Common (+)	ESTS, TETS	“	15	A 41
Signal 1x8 Mux4 Common (-)	“	“	15	B 41
Signal 1x8 Mux4 Channel 1(+)	“	“	15	B 42
Signal 1x8 Mux4 Channel 1(-)	“	“	15	A 42
Signal 1x8 Mux4 Channel 2(+)	“	“	15	A 43
Signal 1x8 Mux4 Channel 2(-)	“	“	15	B 43
Signal 1x8 Mux4 Channel 3(+)	“	“	15	B 44
Signal 1x8 Mux4 Channel 3(-)	“	“	15	A 44
Signal 1x8 Mux4 Channel 4(+)	“	“	15	A 45
Signal 1x8 Mux4 Channel 4(-)	“	“	15	B 45
Signal 1x8 Mux4 Channel 5(+)	“	“	15	B 46
Signal 1x8 Mux4 Channel 5(-)	“	“	15	A 46
Signal 1x8 Mux4 Channel 6(+)	“	“	15	A 47
Signal 1x8 Mux4 Channel 6(-)	“	“	15	B 47
Signal 1x8 Mux4 Channel 7(+)	TETS	“	15	B 48
Signal 1x8 Mux4 Channel 7(-)	“	“	15	A 48
Signal 1x8 Mux4 Channel 8(+)	“	“	15	A 49
Signal 1x8 Mux4 Channel 8(-)	“	“	15	B 49
Signal 1x8 Mux5 Common (+)	ESTS, TETS	“	15	D 14
Signal 1x8 Mux5 Common (-)	“	“	15	C 14
Signal 1x8 Mux5 Channel 1(+)	“	“	15	C 15
Signal 1x8 Mux5 Channel 1(-)	“	“	15	D 15
Signal 1x8 Mux5 Channel 2(+)	“	“	15	D 16
Signal 1x8 Mux5 Channel 2(-)	“	“	15	C 16
Signal 1x8 Mux5 Channel 3(+)	“	“	15	C 17
Signal 1x8 Mux5 Channel 3(-)	“	“	15	D 17
Signal 1x8 Mux5 Channel 4(+)	“	“	15	D 18
Signal 1x8 Mux5 Channel 4(-)	“	“	15	C 18
Signal 1x8 Mux5 Channel 5(+)	“	“	15	C 19
Signal 1x8 Mux5 Channel 5(-)	“	“	15	D 19
Signal 1x8 Mux5 Channel 6(+)	“	“	15	D 20
Signal 1x8 Mux5 Channel 6(-)	“	“	15	C 20
Signal 1x8 Mux5 Channel 7(+)	TETS	“	15	C 21
Signal 1x8 Mux5 Channel 7(-)	“	“	15	D 21
Signal 1x8 Mux5 Channel 8(+)	“	“	15	D 22
Signal 1x8 Mux5 Channel 8(-)	“	“	15	C 22
Signal 1x8 Mux6 Common (+)	ESTS, TETS	“	15	C 23
Signal 1x8 Mux6 Common (-)	“	“	15	D 23
Signal 1x8 Mux6 Channel 1(+)	“	“	15	D 24
Signal 1x8 Mux6 Channel 1(-)	“	“	15	C 24
Signal 1x8 Mux6 Channel 2(+)	“	“	15	C 25
Signal 1x8 Mux6 Channel 2(-)	“	“	15	D 25
Signal 1x8 Mux6 Channel 3(+)	“	“	15	D 26
Signal 1x8 Mux6 Channel 3(-)	“	“	15	C 26

**Table A.44—1x8 switch (continued)**

CTI name	Legacy systems	Recommended attributes	Slot	Pin
Signal 1x8 Mux6 Channel 4(+)	“	“	15	C 27
Signal 1x8 Mux6 Channel 4(-)	“	“	15	D 27
Signal 1x8 Mux6 Channel 5(+)	“	“	15	D 28
Signal 1x8 Mux6 Channel 5(-)	“	“	15	C 28
Signal 1x8 Mux6 Channel 6(+)	“	“	15	C 29
Signal 1x8 Mux6 Channel 6(-)	“	“	15	D 29
Signal 1x8 Mux6 Channel 7(+)	TETS	“	15	D 30
Signal 1x8 Mux6 Channel 7(-)	“	“	15	C 30
Signal 1x8 Mux6 Channel 8(+)	“	“	15	C 31
Signal 1x8 Mux6 Channel 8(-)	“	“	15	D 31
Signal 1x8 Mux7 Common (+)	ESTS, TETS	“	15	D 32
Signal 1x8 Mux7 Common (-)	“	“	15	C 32
Signal 1x8 Mux7 Channel 1(+)	“	“	15	C 33
Signal 1x8 Mux7 Channel 1(-)	“	“	15	D 33
Signal 1x8 Mux7 Channel 2(+)	“	“	15	D 34
Signal 1x8 Mux7 Channel 2(-)	“	“	15	C 34
Signal 1x8 Mux7 Channel 3(+)	“	“	15	C 35
Signal 1x8 Mux7 Channel 3(-)	“	“	15	D 35
Signal 1x8 Mux7 Channel 4(+)	“	“	15	D 36
Signal 1x8 Mux7 Channel 4(-)	“	“	15	C 36
Signal 1x8 Mux7 Channel 5(+)	“	“	15	C 37
Signal 1x8 Mux7 Channel 5(-)	“	“	15	D 37
Signal 1x8 Mux7 Channel 6(+)	“	“	15	D 38
Signal 1x8 Mux7 Channel 6(-)	“	“	15	C 38
Signal 1x8 Mux7 Channel 7(+)	TETS	“	15	C 39
Signal 1x8 Mux7 Channel 7(-)	“	“	15	D 39
Signal 1x8 Mux7 Channel 8(+)	“	“	15	D 40
Signal 1x8 Mux7 Channel 8(-)	“	“	15	C 40
Signal 1x8 Mux8 Common (+)	ESTS, TETS	“	15	C 41
Signal 1x8 Mux8 Common (-)	“	“	15	D 41
Signal 1x8 Mux8 Channel 1(+)	“	“	15	D 42
Signal 1x8 Mux8 Channel 1(-)	“	“	15	C 42
Signal 1x8 Mux8 Channel 2(+)	“	“	15	C 43
Signal 1x8 Mux8 Channel 2(-)	“	“	15	D 43
Signal 1x8 Mux8 Channel 3(+)	“	“	15	D 44
Signal 1x8 Mux8 Channel 3(-)	“	“	15	C 44
Signal 1x8 Mux8 Channel 4(+)	“	“	15	C 45
Signal 1x8 Mux8 Channel 4(-)	“	“	15	D 45
Signal 1x8 Mux8 Channel 5(+)	“	“	15	D 46
Signal 1x8 Mux8 Channel 5(-)	“	“	15	C 46
Signal 1x8 Mux8 Channel 6(+)	“	“	15	C 47
Signal 1x8 Mux8 Channel 6(-)	“	“	15	D 47
Signal 1x8 Mux8 Channel 7(+)	TETS	“	15	D 48
Signal 1x8 Mux8 Channel 7(-)	“	“	15	C 48
Signal 1x8 Mux8 Channel 8(+)	“	“	15	C 49
Signal 1x8 Mux8 Channel 8(-)	“	“	15	D 49
Signal 1x8 Mux9 Common (+)	ESTS, TETS	“	16	B 14
Signal 1x8 Mux9 Common (-)	“	“	16	A 14
Signal 1x8 Mux9 Channel 1(+)	“	“	16	A 15
Signal 1x8 Mux9 Channel 1(-)	“	“	16	B 15
Signal 1x8 Mux9 Channel 2(+)	“	“	16	B 16

Table A.44—1x8 switch (continued)

CTI name	Legacy systems	Recommended attributes	Slot	Pin
Signal 1x8 Mux9 Channel 2(-)	“	“	16	A 16
Signal 1x8 Mux9 Channel 3(+)	“	“	16	A 17
Signal 1x8 Mux9 Channel 3(-)	“	“	16	B 17
Signal 1x8 Mux9 Channel 4(+)	“	“	16	B 18
Signal 1x8 Mux9 Channel 4(-)	“	“	16	A 18
Signal 1x8 Mux9 Channel 5(+)	“	“	16	A 19
Signal 1x8 Mux9 Channel 5(-)	“	“	16	B 19
Signal 1x8 Mux9 Channel 6(+)	“	“	16	B 20
Signal 1x8 Mux9 Channel 6(-)	“	“	16	A 20
Signal 1x8 Mux9 Channel 7(+)	TETS	“	16	A 21
Signal 1x8 Mux9 Channel 7(-)	“	“	16	B 21
Signal 1x8 Mux9 Channel 8(+)	“	“	16	B 22
Signal 1x8 Mux9 Channel 8(-)	“	“	16	A 22
Signal 1x8 Mux10 Common (+)	ESTS, TETS	“	16	A 23
Signal 1x8 Mux10 Common (-)	“	“	16	B 23
Signal 1x8 Mux10 Channel 1(+)	“	“	16	B 24
Signal 1x8 Mux10 Channel 1(-)	“	“	16	A 24
Signal 1x8 Mux10 Channel 2(+)	“	“	16	A 25
Signal 1x8 Mux10 Channel 2(-)	“	“	16	B 25
Signal 1x8 Mux10 Channel 3(+)	“	“	16	B 26
Signal 1x8 Mux10 Channel 3(-)	“	“	16	A 26
Signal 1x8 Mux10 Channel 4(+)	“	“	16	A 27
Signal 1x8 Mux10 Channel 4(-)	“	“	16	B 27
Signal 1x8 Mux10 Channel 5(+)	“	“	16	B 28
Signal 1x8 Mux10 Channel 5(-)	“	“	16	A 28
Signal 1x8 Mux10 Channel 6(+)	“	“	16	A 29
Signal 1x8 Mux10 Channel 6(-)	“	“	16	B 29
Signal 1x8 Mux10 Channel 7(+)	TETS	“	16	B 30
Signal 1x8 Mux10 Channel 7(-)	“	“	16	A 30
Signal 1x8 Mux10 Channel 8(+)	“	“	16	A 31
Signal 1x8 Mux10 Channel 8(-)	“	“	16	B 31
Signal 1x8 Mux11 Common (+)	ESTS, TETS	“	16	B 32
Signal 1x8 Mux11 Common (-)	“	“	16	A 32
Signal 1x8 Mux11 Channel 1(+)	“	“	16	A 33
Signal 1x8 Mux11 Channel 1(-)	“	“	16	B 33
Signal 1x8 Mux11 Channel 2(+)	“	“	16	B 34
Signal 1x8 Mux11 Channel 2(-)	“	“	16	A 34
Signal 1x8 Mux11 Channel 3(+)	“	“	16	A 35
Signal 1x8 Mux11 Channel 3(-)	“	“	16	B 35
Signal 1x8 Mux11 Channel 4(+)	“	“	16	B 36
Signal 1x8 Mux11 Channel 4(-)	“	“	16	A 36
Signal 1x8 Mux11 Channel 5(+)	“	“	16	A 37
Signal 1x8 Mux11 Channel 5(-)	“	“	16	B 37
Signal 1x8 Mux11 Channel 6(+)	“	“	16	B 38
Signal 1x8 Mux11 Channel 6(-)	“	“	16	A 38
Signal 1x8 Mux11 Channel 7(+)	TETS	“	16	A 39
Signal 1x8 Mux11 Channel 7(-)	“	“	16	B 39
Signal 1x8 Mux11 Channel 8(+)	“	“	16	B 40
Signal 1x8 Mux11 Channel 8(-)	“	“	16	A 40
Signal 1x8 Mux12 Common (+)	ESTS, TETS	“	16	A 41
Signal 1x8 Mux12 Common (-)	“	“	16	B 41
Signal 1x8 Mux12 Channel 1(+)	“	“	16	B 42
Signal 1x8 Mux12 Channel 1(-)	“	“	16	A 42

**Table A.44—1x8 switch (continued)**

CTI name	Legacy systems	Recommended attributes	Slot	Pin
Signal 1x8 Mux12 Channel 2(+)	“	“	16	A 43
Signal 1x8 Mux12 Channel 2(-)	“	“	16	B 43
Signal 1x8 Mux12 Channel 3(+)	“	“	16	B 44
Signal 1x8 Mux12 Channel 3(-)	“	“	16	A 44
Signal 1x8 Mux12 Channel 4(+)	“	“	16	A 45
Signal 1x8 Mux12 Channel 4(-)	“	“	16	B 45
Signal 1x8 Mux12 Channel 5(+)	“	“	16	B 46
Signal 1x8 Mux12 Channel 5(-)	“	“	16	A 46
Signal 1x8 Mux12 Channel 6(+)	“	“	16	A 47
Signal 1x8 Mux12 Channel 6(-)	“	“	16	B 47
Signal 1x8 Mux12 Channel 7(+)	TETS	“	16	B 48
Signal 1x8 Mux12 Channel 7(-)	“	“	16	A 48
Signal 1x8 Mux12 Channel 8(+)	“	“	16	A 49
Signal 1x8 Mux12 Channel 8(-)	“	“	16	B 49
Signal 1x8 Mux13 Common (+)	ESTS, TETS	“	16	D 14
Signal 1x8 Mux13 Common (-)	“	“	16	C 14
Signal 1x8 Mux13 Channel 1(+)	“	“	16	C 15
Signal 1x8 Mux13 Channel 1(-)	“	“	16	D 15
Signal 1x8 Mux13 Channel 2(+)	“	“	16	D 16
Signal 1x8 Mux13 Channel 2(-)	“	“	16	C 16
Signal 1x8 Mux13 Channel 3(+)	“	“	16	C 17
Signal 1x8 Mux13 Channel 3(-)	“	“	16	D 17
Signal 1x8 Mux13 Channel 4(+)	“	“	16	D 18
Signal 1x8 Mux13 Channel 4(-)	“	“	16	C 18
Signal 1x8 Mux13 Channel 5(+)	“	“	16	C 19
Signal 1x8 Mux13 Channel 5(-)	“	“	16	D 19
Signal 1x8 Mux13 Channel 6(+)	“	“	16	D 20
Signal 1x8 Mux13 Channel 6(-)	“	“	16	C 20
Signal 1x8 Mux13 Channel 7(+)	TETS	“	16	C 21
Signal 1x8 Mux13 Channel 7(-)	“	“	16	D 21
Signal 1x8 Mux13 Channel 8(+)	“	“	16	D 22
Signal 1x8 Mux13 Channel 8(-)	“	“	16	C 22
Signal 1x8 Mux14 Common (+)	ESTS, TETS	“	16	C 23
Signal 1x8 Mux14 Common (-)	“	“	16	D 23
Signal 1x8 Mux14 Channel 1(+)	“	“	16	D 24
Signal 1x8 Mux14 Channel 1(-)	“	“	16	C 24
Signal 1x8 Mux14 Channel 2(+)	“	“	16	C 25
Signal 1x8 Mux14 Channel 2(-)	“	“	16	D 25
Signal 1x8 Mux14 Channel 3(+)	“	“	16	D 26
Signal 1x8 Mux14 Channel 3(-)	“	“	16	C 26
Signal 1x8 Mux14 Channel 4(+)	“	“	16	C 27
Signal 1x8 Mux14 Channel 4(-)	“	“	16	D 27
Signal 1x8 Mux14 Channel 5(+)	“	“	16	D 28
Signal 1x8 Mux14 Channel 5(-)	“	“	16	C 28
Signal 1x8 Mux14 Channel 6(+)	“	“	16	C 29
Signal 1x8 Mux14 Channel 6(-)	“	“	16	D 29
Signal 1x8 Mux14 Channel 7(+)	TETS	“	16	D 30
Signal 1x8 Mux14 Channel 7(-)	“	“	16	C 30
Signal 1x8 Mux14 Channel 8(+)	“	“	16	C 31
Signal 1x8 Mux14 Channel 8(-)	“	“	16	D 31

Table A.44—1x8 switch (continued)

CTI name	Legacy systems	Recommended attributes	Slot	Pin
Signal 1x8 Mux15 Common (+)	ESTS, TETS	“	16	D 32
Signal 1x8 Mux15 Common (-)	“	“	16	C 32
Signal 1x8 Mux15 Channel 1(+)	“	“	16	C 33
Signal 1x8 Mux15 Channel 1(-)	“	“	16	D 33
Signal 1x8 Mux15 Channel 2(+)	“	“	16	D 34
Signal 1x8 Mux15 Channel 2(-)	“	“	16	C 34
Signal 1x8 Mux15 Channel 3(+)	“	“	16	C 35
Signal 1x8 Mux15 Channel 3(-)	“	“	16	D 35
Signal 1x8 Mux15 Channel 4(+)	“	“	16	D 36
Signal 1x8 Mux15 Channel 4(-)	“	“	16	C 36
Signal 1x8 Mux15 Channel 5(+)	“	“	16	C 37
Signal 1x8 Mux15 Channel 5(-)	“	“	16	D 37
Signal 1x8 Mux15 Channel 6(+)	“	“	16	D 38
Signal 1x8 Mux15 Channel 6(-)	“	“	16	C 38
Signal 1x8 Mux15 Channel 7(+)	TETS	“	16	C 39
Signal 1x8 Mux15 Channel 7(-)	“	“	16	D 39
Signal 1x8 Mux15 Channel 8(+)	“	“	16	D 40
Signal 1x8 Mux15 Channel 8(-)	“	“	16	C 40
Signal 1x8 Mux16 Common (+)	ESTS, TETS	“	16	C 41
Signal 1x8 Mux16 Common (-)	“	“	16	D 41
Signal 1x8 Mux16 Channel 1(+)	“	“	16	D 42
Signal 1x8 Mux16 Channel 1(-)	“	“	16	C 42
Signal 1x8 Mux16 Channel 2(+)	“	“	16	C 43
Signal 1x8 Mux16 Channel 2(-)	“	“	16	D 43
Signal 1x8 Mux16 Channel 3(+)	“	“	16	D 44
Signal 1x8 Mux16 Channel 3(-)	“	“	16	C 44
Signal 1x8 Mux16 Channel 4(+)	“	“	16	C 45
Signal 1x8 Mux16 Channel 4(-)	“	“	16	D 45
Signal 1x8 Mux16 Channel 5(+)	“	“	16	D 46
Signal 1x8 Mux16 Channel 5(-)	“	“	16	C 46
Signal 1x8 Mux16 Channel 6(+)	“	“	16	C 47
Signal 1x8 Mux16 Channel 6(-)	“	“	16	D 47
Signal 1x8 Mux16 Channel 7(+)	TETS	“	16	D 48
Signal 1x8 Mux16 Channel 7(-)	“	“	16	C 48
Signal 1x8 Mux16 Channel 8(+)	“	“	16	C 49
Signal 1x8 Mux16 Channel 8(-)	“	“	16	D 49

**Table A.45—8x24 MUX**

CTI name	Legacy systems	Recommended attributes	Slot	Pin
Signal 8x24 MUX 1 CH 1 (+)	IFTE, CASS, LM-STAR, ESTS, TETS, IAIS, RAF	Max current: 2 A Max voltage: 300 Vdc/ 300 Vac Max switching power (dc): 60 W Max switching power (ac): 125 VA	8	C 43
Signal 8x24 MUX 1 CH 1 (-)	“	“	8	D 43
Signal 8x24 MUX 1 CH 2 (+)	“	“	8	D 44
Signal 8x24 MUX 1 CH 2 (-)	“	“	8	C 44
Signal 8x24 MUX 1 CH 3 (+)	“	“	8	C 45
Signal 8x24 MUX 1 CH 3 (-)	“	“	8	D 45
Signal 8x24 MUX 1 CH 4 (+)	“	“	8	D 46
Signal 8x24 MUX 1 CH 4 (-)	“	“	8	C 46
Signal 8x24 MUX 1 CH 5 (+)	IFTE, CASS, LM-STAR, ESTS, IAIS, RAF	“	8	C 47
Signal 8x24 MUX 1 CH 5 (-)	“	“	8	D 47
Signal 8x24 MUX 1 CH 6 (+)	IFTE, LM-STAR, ESTS, IAIS, RAF	“	8	D 48
Signal 8x24 MUX 1 CH 6 (-)	“	“	8	C 48
Signal 8x24 MUX 1 CH 7 (+)	IFTE, CASS, LM-STAR, ESTS, IAIS, RAF	“	8	C 49
Signal 8x24 MUX 1 CH 7 (-)	“	“	8	D 49
Signal 8x24 MUX 1 CH 8 (+)	“	“	8	D 50
Signal 8x24 MUX 1 CH 8 (-)	“	“	8	C 50
Signal 8x24 MUX 1 CH 9 (+)	IFTE, CASS, LM-STAR, ESTS, TETS, IAIS, RAF	“	9	A 42
Signal 8x24 MUX 1 CH 9 (-)	“	“	9	A 43
Signal 8x24 MUX 1 CH 10 (+)	“	“	9	A 44
Signal 8x24 MUX 1 CH 10 (-)	“	(See NOTE)		
Signal 8x24 MUX 1 CH 11 (+)	“	“	9	A 45
Signal 8x24 MUX 1 CH 11 (-)	“	“	9	A 46
Signal 8x24 MUX 1 CH 12 (+)	“	“	9	A 47
Signal 8x24 MUX 1 CH 12 (-)	“	(See NOTE)		
Signal 8x24 MUX 1 CH 13 (+)	“	“	9	A 48
Signal 8x24 MUX 1 CH 13 (-)	“	“	9	A 49
Signal 8x24 MUX 1 CH 14 (+)	“	“	9	A 50
Signal 8x24 MUX 1 CH 14 (-)	“	(See NOTE)		
Signal 8x24 MUX 1 CH 15 (+)	“	“	9	B 42
Signal 8x24 MUX 1 CH 15 (-)	“	“	9	B 43
Signal 8x24 MUX 1 CH 16 (+)	“	“	9	B 44
Signal 8x24 MUX 1 CH 16 (-)	“	(See NOTE)		
Signal 8x24 MUX 1 CH 17 (+)	“	“	9	B 45
Signal 8x24 MUX 1 CH 17 (-)	“	“	9	B 46
Signal 8x24 MUX 1 CH 18 (+)	“	“	9	B 47
Signal 8x24 MUX 1 CH 18 (-)	“	(See NOTE)		



**Table A.45—8x24 MUX (continued)**

CTI name	Legacy systems	Recommended attributes	Slot	Pin
Signal 8x24 MUX 1 CH 19 (+)	IFTE, CASS, LM-STAR, ESTS, IAIS, RAF	“	9	B 48
Signal 8x24 MUX 1 CH 19 (–)	“	“	9	B 49
Signal 8x24 MUX 1 CH 20 (+)	“	“	9	B 50
Signal 8x24 MUX 1 CH 20 (–)	“	(See NOTE)		
Signal 8x24 MUX 1 CH 21 (+)	IFTE, CASS, LM-STAR, ESTS, TETS, IAIS, RAF	“	9	C 42
Signal 8x24 MUX 1 CH 21 (–)	“	“	9	C 43
Signal 8x24 MUX 1 CH 22 (+)	“	“	9	C 44
Signal 8x24 MUX 1 CH 22 (–)	“	(See NOTE)		
Signal 8x24 MUX 1 CH 23 (+)	“	“	9	C 45
Signal 8x24 MUX 1 CH 23 (–)	“	“	9	C 46
Signal 8x24 MUX 1 CH 24 (+)	“	“	9	C 47
Signal 8x24 MUX 1 CH 24 (–)	“	(See NOTE)		
Signal 8x24 MUX 1 CH 25 (+)	IFTE, CASS, LM-STAR, TETS, IAIS, RAF	“	9	C 48
Signal 8x24 MUX 1 CH 25 (–)	“	“	9	C 49
Signal 8x24 MUX 1 CH 26 (+)	“	“	9	C 50
Signal 8x24 MUX 1 CH 26 (–)	“	(See NOTE)		
Signal 8x24 MUX 1 CH 27 (+)	IFTE, CASS, LM-STAR, IAIS, RAF	“	9	D 42
Signal 8x24 MUX 1 CH 27 (–)	“	“	9	D 43
Signal 8x24 MUX 1 CH 28 (+)	IFTE, LM-STAR, IAIS, RAF	“	9	D 44
Signal 8x24 MUX 1 CH 28 (–)	“	(See NOTE)		
Signal 8x24 MUX 1 CH 29 (+)	IFTE, CASS, LM-STAR, IAIS, RAF	“	9	D 45
Signal 8x24 MUX 1 CH 29 (–)	“	“	9	D 46
Signal 8x24 MUX 1 CH 30 (+)	“	“	9	D 47
Signal 8x24 MUX 1 CH 30 (–)	“	(See NOTE)		
Signal 8x24 MUX 1 CH 31 (+)	“	“	9	D 48
Signal 8x24 MUX 1 CH 31 (–)	“	“	9	D 49
Signal 8x24 MUX 1 CH 32 (+)	“	“	9	D 50
Signal 8x24 MUX 1 CH 32 (–)	“	(See NOTE)		
Signal 8x24 MUX 2 CH 1 (+)	IFTE, CASS, LM-STAR, ESTS, TETS, IAIS, RAF	“	15	A 1
Signal 8x24 MUX 2 CH 1 (–)	“	“	15	B 1
Signal 8x24 MUX 2 CH 2 (+)	IFTE, CASS, LM-STAR, ESTS, TETS, IAIS	“	15	B 2
Signal 8x24 MUX 2 CH 2 (–)	“	“	15	A 2

**Table A.45—8x24 MUX (continued)**

CTI name	Legacy systems	Recommended attributes	Slot	Pin
Signal 8x24 MUX 2 CH 3 (+)	IFTE, CASS, LM-STAR, ESTS, TETS, IAIS,RAF	“	15	A 3
Signal 8x24 MUX 2 CH 3 (–)	“	“	15	B 3
Signal 8x24 MUX 2 CH 4 (+)	“	“	15	B 4
Signal 8x24 MUX 2 CH 4 (–)	“	“	15	A 4
Signal 8x24 MUX 2 CH 5 (+)	IFTE, CASS,LM-STAR, ESTS, IAIS, RAF	“	15	C 1
Signal 8x24 MUX 2 CH 5 (–)	“	“	15	D 1
Signal 8x24 MUX 2 CH 6 (+)	IFTE, LM-STAR, IAIS, RAF	“	15	D 2
Signal 8x24 MUX 2 CH 6 (–)	“	“	15	C 2
Signal 8x24 MUX 2 CH 7 (+)	IFTE, CASS, LM-STAR, IAIS, RAF	“	15	C 3
Signal 8x24 MUX 2 CH 7 (–)	“	“	15	D 3
Signal 8x24 MUX 2 CH 8 (+)	“	“	15	D 4
Signal 8x24 MUX 2 CH 8 (–)	“	“	15	C 4
Signal 8x24 MUX 2 CH 9 (+)	IFTE, CASS, LM-STAR, ESTS, TETS, IAIS, RAF	“	15	A 5
Signal 8x24 MUX 2 CH 9 (–)	“	“	15	A 6
Signal 8x24 MUX 2 CH 10 (+)	“	“	15	A 7
Signal 8x24 MUX 2 CH 10 (–)	“	(See NOTE)		
Signal 8x24 MUX 2 CH 11 (+)	“	“	15	A 8
Signal 8x24 MUX 2 CH 11 (–)	“	“	15	A 9
Signal 8x24 MUX 2 CH 12 (+)	“	“	15	A 10
Signal 8x24 MUX 2 CH 12 (–)	“	(See NOTE)		
Signal 8x24 MUX 2 CH 13 (+)	“	“	15	A 11
Signal 8x24 MUX 2 CH 13 (–)	“	“	15	A 12
Signal 8x24 MUX 2 CH 14 (+)	“	“	15	A 13
Signal 8x24 MUX 2 CH 14 (–)	“	(See NOTE)		
Signal 8x24 MUX 2 CH 15 (+)	“	“	15	B 5
Signal 8x24 MUX 2 CH 15 (–)	“	“	15	B 6
Signal 8x24 MUX 2 CH 16 (+)	“	“	15	B 7
Signal 8x24 MUX 2 CH 16 (–)	“	(See NOTE)		
Signal 8x24 MUX 2 CH 17 (+)	“	“	15	B 8
Signal 8x24 MUX 2 CH 17 (–)	“	“	15	B 9
Signal 8x24 MUX 2 CH 18 (+)	“	“	15	B 10
Signal 8x24 MUX 2 CH 18 (–)	“	(See NOTE)		
Signal 8x24 MUX 2 CH 19 (+)	IFTE, CASS, LM-STAR, ESTS, IAIS, RAF	“	15	B 11
Signal 8x24 MUX 2 CH 19 (–)	“	“	15	B 12
Signal 8x24 MUX 2 CH 20 (+)	“	“	15	B 13
Signal 8x24 MUX 2 CH 20 (–)	“	“		

**Table A.45—8x24 MUX (continued)**

CTI name	Legacy systems	Recommended attributes	Slot	Pin
Signal 8x24 MUX 2 CH 21 (+)	IFTE, CASS, LM-STAR, ESTS, TETS, IAIS, RAF	“	15	C 5
Signal 8x24 MUX 2 CH 21 (–)	“	“	15	C 6
Signal 8x24 MUX 2 CH 22 (+)	“	“	15	C 7
Signal 8x24 MUX 2 CH 22 (–)	“	(See NOTE)		
Signal 8x24 MUX 2 CH 23 (+)	“	“	15	C 8
Signal 8x24 MUX 2 CH 23 (–)	“	“	15	C 9
Signal 8x24 MUX 2 CH 24 (+)	“	“	15	C 10
Signal 8x24 MUX 2 CH 24 (–)	“	(See NOTE)		
Signal 8x24 MUX 2 CH 25 (+)	“	“	15	C 11
Signal 8x24 MUX 2 CH 25 (–)	“	“	15	C 12
Signal 8x24 MUX 2 CH 26 (+)	IFTE, CASS, LM-STAR, TETS, IAIS, RAF	“	15	C 13
Signal 8x24 MUX 2 CH 26 (–)	“	(See NOTE)		
Signal 8x24 MUX 2 CH 27 (+)	IFTE, CASS, LM-STAR, IAIS, RAF	“	15	D 5
Signal 8x24 MUX 2 CH 27 (–)	“	“	15	D 6
Signal 8x24 MUX 2 CH 28 (+)	IFTE, LM-STAR, IAIS, RAF	“	15	D 7
Signal 8x24 MUX 2 CH 28 (–)	“	(See NOTE)		
Signal 8x24 MUX 2 CH 29 (+)	IFTE, CASS, LM-STAR, IAIS, RAF	“	15	D 8
Signal 8x24 MUX 2 CH 29 (–)	“	“	15	D 9
Signal 8x24 MUX 2 CH 30 (+)	“	“	15	D 10
Signal 8x24 MUX 2 CH 30 (–)	“	(See NOTE)		
Signal 8x24 MUX 2 CH 31 (+)	“	“	15	D 11
Signal 8x24 MUX 2 CH 31 (–)	“	“	15	D 12
Signal 8x24 MUX 2 CH 32 (+)	“	“	15	D 13
Signal 8x24 MUX 2 CH 32 (–)	“	(See NOTE)		
Signal 8x24 MUX 3 CH 1 (+)	IFTE, CASS, LM-STAR, TETS, IAIS, RAF	“	16	A 1
Signal 8x24 MUX 3 CH 1 (–)	“	“	16	B 1
Signal 8x24 MUX 3 CH 2 (+)	“	“	16	B 2
Signal 8x24 MUX 3 CH 2 (–)	“	“	16	A 2
Signal 8x24 MUX 3 CH 3 (+)	“	“	16	A 3
Signal 8x24 MUX 3 CH 3 (–)	“	“	16	B 3
Signal 8x24 MUX 3 CH 4 (+)	IFTE, CASS, LM-STAR, TETS, IAIS	“	16	B 4
Signal 8x24 MUX 3 CH 4 (–)	“	“	16	A 4
Signal 8x24 MUX 3 CH 5 (+)	IFTE, CASS, LM-STAR, IAIS, RAF	“	16	C 1
Signal 8x24 MUX 3 CH 5 (–)	“	“	16	D 1

**Table A.45—8x24 MUX (continued)**

CTI name	Legacy systems	Recommended attributes	Slot	Pin
Signal 8x24 MUX 3 CH 6 (+)	IFTE, LM-STAR, IAIS, RAF	“	16	D 2
Signal 8x24 MUX 3 CH 6 (–)	“	“	16	C 2
Signal 8x24 MUX 3 CH 7 (+)	IFTE, CASS, LM-STAR, IAIS, RAF	“	16	C 3
Signal 8x24 MUX 3 CH 7 (–)	“	“	16	D 3
Signal 8x24 MUX 3 CH 8 (+)	“	“	16	D 4
Signal 8x24 MUX 3 CH 8 (–)	“	“	16	C 4
Signal 8x24 MUX 3 CH 9 (+)	IFTE, CASS, LM-STAR, TETS, IAIS, RAF	“	16	A 5
Signal 8x24 MUX 3 CH 9 (–)	“	“	16	A 6
Signal 8x24 MUX 3 CH 10 (+)	“	“	16	A 7
Signal 8x24 MUX 3 CH 10 (–)	“	(See NOTE)		
Signal 8x24 MUX 3 CH 11 (+)	“	“	16	A 8
Signal 8x24 MUX 3 CH 11 (–)	“	“	16	A 9
Signal 8x24 MUX 3 CH 12 (+)	“	“	16	A 10
Signal 8x24 MUX 3 CH 12 (–)	“	(See NOTE)		
Signal 8x24 MUX 3 CH 13 (+)	“	“	16	A 11
Signal 8x24 MUX 3 CH 13 (–)	“	“	16	A 12
Signal 8x24 MUX 3 CH 14 (+)	“	“	16	A 13
Signal 8x24 MUX 3 CH 14 (–)	“	(See NOTE)		
Signal 8x24 MUX 3 CH 15 (+)	“	“	16	B 5
Signal 8x24 MUX 3 CH 15 (–)	“	“	16	B 6
Signal 8x24 MUX 3 CH 16 (+)	“	“	16	B 7
Signal 8x24 MUX 3 CH 16 (–)	“	(See NOTE)		
Signal 8x24 MUX 3 CH 17 (+)	“	“	16	B 8
Signal 8x24 MUX 3 CH 17 (–)	“	“	16	B 9
Signal 8x24 MUX 3 CH 18 (+)	“	“	16	B 10
Signal 8x24 MUX 3 CH 18 (–)	“	(See NOTE)		
Signal 8x24 MUX 3 CH 19 (+)	IFTE, CASS, LM-STAR, IAIS, RAF	“	16	B 11
Signal 8x24 MUX 3 CH 19 (–)	“	“	16	B 12
Signal 8x24 MUX 3 CH 20 (+)	“	“	16	B 13
Signal 8x24 MUX 3 CH 20 (–)	“	(See NOTE)		
Signal 8x24 MUX 3 CH 21 (+)	IFTE, CASS, LM-STAR, TETS, IAIS, RAF	“	16	C 5
Signal 8x24 MUX 3 CH 21 (–)	“	“	16	C 6
Signal 8x24 MUX 3 CH 22 (+)	“	“	16	C 7
Signal 8x24 MUX 3 CH 22 (–)	“	(See NOTE)		
Signal 8x24 MUX 3 CH 23 (+)	“	“	16	C 8
Signal 8x24 MUX 3 CH 23 (–)	“	“	16	C 9
Signal 8x24 MUX 3 CH 24 (+)	“	“	16	C 10

**Table A.45—8x24 MUX (continued)**

CTI name	Legacy systems	Recommended attributes	Slot	Pin
Signal 8x24 MUX 3 CH 24 (-)	“	(See NOTE)		
Signal 8x24 MUX 3 CH 25 (+)	“	“	16	C 11
Signal 8x24 MUX 3 CH 25 (-)	“	“	16	C 12
Signal 8x24 MUX 3 CH 26 (+)	“	“	16	C 13
Signal 8x24 MUX 3 CH 26 (-)	“	(See NOTE)		
Signal 8x24 MUX 3 CH 27 (+)	IFTE, CASS, LM-STAR, IAIS, RAF	“	16	D 5
Signal 8x24 MUX 3 CH 27 (-)	“	“	16	D 6
Signal 8x24 MUX 3 CH 28 (+)	IFTE, LM-STAR, IAIS, RAF	“	16	D 7
Signal 8x24 MUX 3 CH 28 (-)	“	(See NOTE)		
Signal 8x24 MUX 3 CH 29 (+)	IFTE, CASS, LM-STAR, IAIS, RAF	“	16	D 8
Signal 8x24 MUX 3 CH 29 (-)	“	“	16	D 9
Signal 8x24 MUX 3 CH 30 (+)	“	“	16	D 10
Signal 8x24 MUX 3 CH 30 (-)	“	(See NOTE)		
Signal 8x24 MUX 3 CH 31 (+)	“	“	16	D 11
Signal 8x24 MUX 3 CH 31 (-)	“	“	16	D 12
Signal 8x24 MUX 3 CH 32 (+)	“	“	16	D 13
Signal 8x24 MUX 3 CH 32 (-)	“	(See NOTE)		
Signal 8x24 MUX 4 CH 1 (+)	IFTE, CASS, LM-STAR, TETS, IAIS, RAF	“	17	A 1
Signal 8x24 MUX 4 CH 1 (-)	“	“	17	B 1
Signal 8x24 MUX 4 CH 2 (+)	“	“	17	B 2
Signal 8x24 MUX 4 CH 2 (-)	“	“	17	A 2
Signal 8x24 MUX 4 CH 3 (+)	“	“	17	A 3
Signal 8x24 MUX 4 CH 3 (-)	“	“	17	B 3
Signal 8x24 MUX 4 CH 4 (+)	“	“	17	B 4
Signal 8x24 MUX 4 CH 4 (-)	“	“	17	A 4
Signal 8x24 MUX 4 CH 5 (+)	IFTE, CASS, LM-STAR, IAIS, RAF	“	17	C 1
Signal 8x24 MUX 4 CH 5 (-)	“	“	17	D 1
Signal 8x24 MUX 4 CH 6 (+)	IFTE, LM-STAR, IAIS	“	17	D 2
Signal 8x24 MUX 4 CH 6 (-)	“	“	17	C 2
Signal 8x24 MUX 4 CH 7 (+)	IFTE, CASS, LM-STAR, IAIS, RAF	“	17	C 3
Signal 8x24 MUX 4 CH 7 (-)	“	“	17	D 3
Signal 8x24 MUX 4 CH 8 (+)	“	“	17	D 4
Signal 8x24 MUX 4 CH 8 (-)	“	“	17	C 4

**Table A.45—8x24 MUX (continued)**

CTI name	Legacy systems	Recommended attributes	Slot	Pin
Signal 8x24 MUX 4 CH 9 (+)	IFTE, CASS, LM-STAR, TETS, IAIS, RAF	“	17	A 5
Signal 8x24 MUX 4 CH 9 (–)	“	“	17	A 6
Signal 8x24 MUX 4 CH 10 (+)	“	“	17	A 7
Signal 8x24 MUX 4 CH 10 (–)	“	(See NOTE)		
Signal 8x24 MUX 4 CH 11 (+)	“	“	17	A 8
Signal 8x24 MUX 4 CH 11 (–)	“	“	17	A 9
Signal 8x24 MUX 4 CH 12 (+)	“	“	17	A 10
Signal 8x24 MUX 4 CH 12 (–)	“	(See NOTE)		
Signal 8x24 MUX 4 CH 13 (+)	“	“	17	A 11
Signal 8x24 MUX 4 CH 13 (–)	“	“	17	A 12
Signal 8x24 MUX 4 CH 14 (+)	“	“	17	A 13
Signal 8x24 MUX 4 CH 14 (–)	“	(See NOTE)		
Signal 8x24 MUX 4 CH 15 (+)	“	“	17	B 5
Signal 8x24 MUX 4 CH 15 (–)	“	“	17	B 6
Signal 8x24 MUX 4 CH 16 (+)	“	“	17	B 7
Signal 8x24 MUX 4 CH 16 (–)	“	(See NOTE)		
Signal 8x24 MUX 4 CH 17 (+)	“	“	17	B 8
Signal 8x24 MUX 4 CH 17 (–)	“	“	17	B 9
Signal 8x24 MUX 4 CH 18 (+)	“	“	17	B 10
Signal 8x24 MUX 4 CH 18 (–)	“	(See NOTE)		
Signal 8x24 MUX 4 CH 19 (+)	IFTE, CASS, LM-STAR, IAIS, RAF	“	17	B 11
Signal 8x24 MUX 4 CH 19 (–)	“	“	17	B 12
Signal 8x24 MUX 4 CH 20 (+)	“	“	17	B 13
Signal 8x24 MUX 4 CH 20 (–)	“	(See NOTE)		
Signal 8x24 MUX 4 CH 21 (+)	IFTE, CASS, LM-STAR, TETS, IAIS, RAF	“	17	C 5
Signal 8x24 MUX 4 CH 21 (–)	“	“	17	C 6
Signal 8x24 MUX 4 CH 22 (+)	“	“	17	C 7
Signal 8x24 MUX 4 CH 22 (–)	“	(See NOTE)		
Signal 8x24 MUX 4 CH 23 (+)	“	“	17	C 8
Signal 8x24 MUX 4 CH 23 (–)	“	“	17	C 9
Signal 8x24 MUX 4 CH 24 (+)	“	“	17	C 10
Signal 8x24 MUX 4 CH 24 (–)	“	(See NOTE)		
Signal 8x24 MUX 4 CH 25 (+)	“	“	17	C 11
Signal 8x24 MUX 4 CH 25 (–)	“	“	17	C 12
Signal 8x24 MUX 4 CH 26 (+)	“	“	17	C 13
Signal 8x24 MUX 4 CH 26 (–)	“	(See NOTE)		

**Table A.45—8x24 MUX (continued)**

CTI name	Legacy systems	Recommended attributes	Slot	Pin
Signal 8x24 MUX 4 CH 27 (+)	IFTE, CASS, LM-STAR, IAIS, RAF	“	17	D 5
Signal 8x24 MUX 4 CH 27 (–)	“	“	17	D 6
Signal 8x24 MUX 4 CH 28 (+)	IFTE, LM-STAR, IAIS, RAF	“	17	D 7
Signal 8x24 MUX 4 CH 28 (–)	“	(See NOTE)		
Signal 8x24 MUX 4 CH 29 (+)	IFTE, CASS, LM-STAR, IAIS, RAF	“	17	D 8
Signal 8x24 MUX 4 CH 29 (–)	“	“	17	D 9
Signal 8x24 MUX 4 CH 30 (+)	“	“	17	D 10
Signal 8x24 MUX 4 CH 30 (–)	“	(See NOTE)		
Signal 8x24 MUX 4 CH 31 (+)	“	“	17	D 11
Signal 8x24 MUX 4 CH 31 (–)	“	“	17	D 12
Signal 8x24 MUX 4 CH 32 (+)	“	“	17	D 13
Signal 8x24 MUX 4 CH 32 (–)	“	(See NOTE)		
Signal 8x24 MUX 5 CH 1 (+)	IFTE, CASS, TETS, RAF	“	17	A 14
Signal 8x24 MUX 5 CH 1 (–)	“	“	17	B 14
Signal 8x24 MUX 5 CH 2 (+)	“	“	17	B 15
Signal 8x24 MUX 5 CH 2 (–)	“	“	17	A 15
Signal 8x24 MUX 5 CH 3 (+)	“	“	17	A 16
Signal 8x24 MUX 5 CH 3 (–)	“	“	17	B 16
Signal 8x24 MUX 5 CH 4 (+)	“	“	17	B 17
Signal 8x24 MUX 5 CH 4 (–)	“	“	17	A 17
Signal 8x24 MUX 5 CH 5 (+)	IFTE, CASS, RAF	“	17	C 14
Signal 8x24 MUX 5 CH 5 (–)	“	“	17	D 14
Signal 8x24 MUX 5 CH 6 (+)	IFTE, RAF	“	17	D 15
Signal 8x24 MUX 5 CH 6 (–)	“	“	17	C 15
Signal 8x24 MUX 5 CH 7 (+)	IFTE, CASS, RAF	“	17	C 16
Signal 8x24 MUX 5 CH 7 (–)	“	“	17	D 16
Signal 8x24 MUX 5 CH 8 (+)	IFTE, CASS	“	17	D 17
Signal 8x24 MUX 5 CH 8 (–)	“	“	17	C 17
Signal 8x24 MUX 5 CH 9 (+)	IFTE, CASS, TETS, RAF	“	17	A 18
Signal 8x24 MUX 5 CH 9 (–)	“	“	17	A 19
Signal 8x24 MUX 5 CH 10 (+)	“	“	17	A 20
Signal 8x24 MUX 5 CH 10 (–)	“	(See NOTE)		
Signal 8x24 MUX 5 CH 11 (+)	“	“	17	A 21
Signal 8x24 MUX 5 CH 11 (–)	“	“	17	A 22
Signal 8x24 MUX 5 CH 12 (+)	“	“	17	A 23
Signal 8x24 MUX 5 CH 12 (–)	“	(See NOTE)		
Signal 8x24 MUX 5 CH 13 (+)	“	“	17	A 24
Signal 8x24 MUX 5 CH 13 (–)	“	“	17	A 25
Signal 8x24 MUX 5 CH 14 (+)	“	“	17	A 26

**Table A.45—8x24 MUX (continued)**

CTI name	Legacy systems	Recommended attributes	Slot	Pin
Signal 8x24 MUX 5 CH 14 (–)	“	(See NOTE)		
Signal 8x24 MUX 5 CH 15 (+)	“	“	17	B 18
Signal 8x24 MUX 5 CH 15 (–)	“	“	17	B 19
Signal 8x24 MUX 5 CH 16 (+)	“	“	17	B 20
Signal 8x24 MUX 5 CH 16 (–)	“	(See NOTE)		
Signal 8x24 MUX 5 CH 17 (+)	“	“	17	B 21
Signal 8x24 MUX 5 CH 17 (–)	“	“	17	B 22
Signal 8x24 MUX 5 CH 18 (+)	“	“	17	B 23
Signal 8x24 MUX 5 CH 18 (–)	“	(See NOTE)		
Signal 8x24 MUX 5 CH 19 (+)	IFTE, CASS	“	17	B 24
Signal 8x24 MUX 5 CH 19 (–)	“	“	17	B 25
Signal 8x24 MUX 5 CH 20 (+)	“	“	17	B 26
Signal 8x24 MUX 5 CH 20 (–)	“	(See NOTE)		
Signal 8x24 MUX 5 CH 21 (+)	IFTE, CASS, TETS	“	17	C 18
Signal 8x24 MUX 5 CH 21 (–)	“	“	17	C 19
Signal 8x24 MUX 5 CH 22 (+)	“	“	17	C 20
Signal 8x24 MUX 5 CH 22 (–)	“	(See NOTE)		
Signal 8x24 MUX 5 CH 23 (+)	“	“	17	C 21
Signal 8x24 MUX 5 CH 23 (–)	“	“	17	C 22
Signal 8x24 MUX 5 CH 24 (+)	“	“	17	C 23
Signal 8x24 MUX 5 CH 24 (–)	“	(See NOTE)		
Signal 8x24 MUX 5 CH 25 (+)	“	“	17	C 24
Signal 8x24 MUX 5 CH 25 (–)	“	“	17	C 25
Signal 8x24 MUX 5 CH 26 (+)	“	“	17	C 26
Signal 8x24 MUX 5 CH 26 (–)	“	(See NOTE)		
Signal 8x24 MUX 5 CH 27 (+)	IFTE, CASS	“	17	D 18
Signal 8x24 MUX 5 CH 27 (–)	IFTE, CASS	“	17	D 19
Signal 8x24 MUX 5 CH 28 (+)	IFTE	“	17	D 20
Signal 8x24 MUX 5 CH 28 (–)	“	(See NOTE)		
Signal 8x24 MUX 5 CH 29 (+)	IFTE, CASS	“	17	D 21
Signal 8x24 MUX 5 CH 29 (–)	“	“	17	D 22
Signal 8x24 MUX 5 CH 30 (+)	“	“	17	D 23
Signal 8x24 MUX 5 CH 30 (–)	“	(See NOTE)		
Signal 8x24 MUX 5 CH 31 (+)	“	“	17	D 24
Signal 8x24 MUX 5 CH 31 (–)	“	“	17	D 25
Signal 8x24 MUX 5 CH 32 (+)	“	“	17	D 26
Signal 8x24 MUX 5 CH 32 (–)	“	(See NOTE)		
Signal 8x24 MUX 6 CH 1 (+)	IFTE, CASS, TETS	“	17	A 27
Signal 8x24 MUX 6 CH 1 (–)	“	“	17	B 27
Signal 8x24 MUX 6 CH 2 (+)	“	“	17	B 28
Signal 8x24 MUX 6 CH 2 (–)	“	“	17	A 28
Signal 8x24 MUX 6 CH 3 (+)	“	“	17	A 29
Signal 8x24 MUX 6 CH 3 (–)	“	“	17	B 29
Signal 8x24 MUX 6 CH 4 (+)	“	“	17	B 30



Table A.45—8x24 MUX (continued)

CTI name	Legacy systems	Recommended attributes	Slot	Pin
Signal 8x24 MUX 6 CH 4 (–)	“	“	17	A 30
Signal 8x24 MUX 6 CH 5 (+)	“	“	17	C 27
Signal 8x24 MUX 6 CH 5 (–)	“	“	17	D 27
Signal 8x24 MUX 6 CH 6 (+)	IFTE	“	17	D 28
Signal 8x24 MUX 6 CH 6 (–)	IFTE	“	17	C 28
Signal 8x24 MUX 6 CH 7 (+)	IFTE, CASS, TETS	“	17	C 29
Signal 8x24 MUX 6 CH 7 (–)	“	“	17	D 29
Signal 8x24 MUX 6 CH 8 (+)	IFTE, CASS	“	17	D 30
Signal 8x24 MUX 6 CH 8 (–)	“	“	17	C 30
Signal 8x24 MUX 6 CH 9 (+)	IFTE, CASS, TETS	“	17	A 31
Signal 8x24 MUX 6 CH 9 (–)	“	“	17	A 32
Signal 8x24 MUX 6 CH 10 (+)	“	“	17	A 33
Signal 8x24 MUX 6 CH 10 (–)	“	(See NOTE)		
Signal 8x24 MUX 6 CH 11 (+)	“	“	17	A 34
Signal 8x24 MUX 6 CH 11 (–)	“	“	17	A 35
Signal 8x24 MUX 6 CH 12 (+)	“	“	17	A 36
Signal 8x24 MUX 6 CH 12 (–)	“	(See NOTE)		
Signal 8x24 MUX 6 CH 13 (+)	“	“	17	A 37
Signal 8x24 MUX 6 CH 13 (–)	“	“	17	A 38
Signal 8x24 MUX 6 CH 14 (+)	“	“	17	A 39
Signal 8x24 MUX 6 CH 14 (–)	“	(See NOTE)		
Signal 8x24 MUX 6 CH 15 (+)	“	“	17	B 31
Signal 8x24 MUX 6 CH 15 (–)	“	“	17	B 32
Signal 8x24 MUX 6 CH 16 (+)	“	“	17	B 33
Signal 8x24 MUX 6 CH 16 (–)	“	(See NOTE)		
Signal 8x24 MUX 6 CH 17 (+)	“	“	17	B 34
Signal 8x24 MUX 6 CH 17 (–)	“	“	17	B 35
Signal 8x24 MUX 6 CH 18 (+)	“	“	17	B 36
Signal 8x24 MUX 6 CH 18 (–)	“	(See NOTE)		
Signal 8x24 MUX 6 CH 19 (+)	IFTE, CASS	“	17	B 37
Signal 8x24 MUX 6 CH 19 (–)	“	“	17	B 38
Signal 8x24 MUX 6 CH 20 (+)	“	“	17	B 39
Signal 8x24 MUX 6 CH 20 (–)	“	(See NOTE)		
Signal 8x24 MUX 6 CH 21 (+)	IFTE, CASS, TETS	“	17	C 31
Signal 8x24 MUX 6 CH 21 (–)	“	“	17	C 32
Signal 8x24 MUX 6 CH 22 (+)	“	“	17	C 33
Signal 8x24 MUX 6 CH 22 (–)	“	(See NOTE)		
Signal 8x24 MUX 6 CH 23 (+)	IFTE, CASS	“	17	C 34
Signal 8x24 MUX 6 CH 23 (–)	“	“	17	C 35
Signal 8x24 MUX 6 CH 24 (+)	“	“	17	C 36
Signal 8x24 MUX 6 CH 24 (–)	“	(See NOTE)		
Signal 8x24 MUX 6 CH 25 (+)	“	“	17	C 37
Signal 8x24 MUX 6 CH 25 (–)	“	“	17	C 38
Signal 8x24 MUX 6 CH 26 (+)	“	“	17	C 39

**Table A.45—8x24 MUX (continued)**

CTI name	Legacy systems	Recommended attributes	Slot	Pin
Signal 8x24 MUX 6 CH 26 (–)	“	(See NOTE)		
Signal 8x24 MUX 6 CH 27 (+)	“	“	17	D 31
Signal 8x24 MUX 6 CH 27 (–)	“	“	17	D 32
Signal 8x24 MUX 6 CH 28 (+)	IFTE	“	17	D 33
Signal 8x24 MUX 6 CH 28 (–)	“	(See NOTE)		
Signal 8x24 MUX 6 CH 29 (+)	IFTE, CASS	“	17	D 34
Signal 8x24 MUX 6 CH 29 (–)	“	“	17	D 35
Signal 8x24 MUX 6 CH 30 (+)	“	“	17	D 36
Signal 8x24 MUX 6 CH 30 (–)	“	(See NOTE)		
Signal 8x24 MUX 6 CH 31 (+)	“	“	17	D 37
Signal 8x24 MUX 6 CH 31 (–)	“	“	17	D 38
Signal 8x24 MUX 6 CH 32 (+)	“	“	17	D 39
Signal 8x24 MUX 6 CH 32 (–)	“	(See NOTE)		
NOTE—Output return pins tie together to save on pin count.				

Table A.46—1x4 switch

CTI name	Legacy systems	Recommended attributes	Slot	Pin
1x4 SSW1 Common	CASS, LM-STAR, TETS, C17	Max voltage: 300 V Max current: 2 A Min switch speed: 15 ms Min breakdown Voltage: 1 kVdc Freq range: dc to 10 MHz Max switch path resistance (@ 1 mA): 1 $\Omega$ Min open switch isolation: 10 000 M $\Omega$	8	A 36
1x4 SSW1 Port1	“	“	8	A 37
1x4 SSW1 Port2	“	“	8	A 38
1x4 SSW1 Port3	CASS, LM-STAR, TETS	“	8	A 39
1x4 SSW1 Port4	“	“	8	A 40
1x4 SSW2 Common	CASS, LM-STAR, TETS, C17	“	8	B 36
1x4 SSW2 Port1	“	“	8	B 37
1x4 SSW2 Port2	“	“	8	B 38
1x4 SSW2 Port3	CASS, LM-STAR, TETS	“	8	B 39
1x4 SSW2 Port4	“	“	8	B 40
1x4 SSW3 Common	CASS, LM-STAR, TETS, C17	“	9	A 36
1x4 SSW3 Port1	“	“	9	A 37
1x4 SSW3 Port2	“	“	9	A 38
1x4 SSW3 Port3	CASS, LM-STAR, TETS	“	9	A 39
1x4 SSW3 Port4	“	“	9	A 40
1x4 SSW4 Common	CASS, LM-STAR, TETS, C17	“	9	B 36
1x4 SSW4 Port1	“	“	9	B 37
1x4 SSW4 Port2	“	“	9	B 38
1x4 SSW4 Port3	CASS, LM-STAR, TETS	“	9	B 39
1x4 SSW4 Port4	“	“	9	B 40
1x4 SSW5 Common	CASS, LM-STAR, TETS, C17	“	17	A 40
1x4 SSW5 Port1	“	“	17	A 41
1x4 SSW5 Port2	“	“	17	A 42
1x4 SSW5 Port3	CASS, LM-STAR, TETS	“	17	A 43
1x4 SSW5 Port4	“	“	17	A 44
1x4 SSW6 Common	CASS, LM-STAR, TETS, C17	“	17	A 45
1x4 SSW6 Port1	“	“	17	A 46
1x4 SSW6 Port2	“	“	17	A 47
1x4 SSW6 Port3	CASS, LM-STAR, TETS	“	17	A 48
1x4 SSW6 Port4	“	“	17	A 49
1x4 SSW7 Common	LM-STAR, TETS, C17	“	17	B 40
1x4 SSW7 Port1	“	“	17	B 41
1x4 SSW7 Port2	“	“	17	B 42
1x4 SSW7 Port3	LM-STAR	“	17	B 43
1x4 SSW7 Port4	LM-STAR	“	17	B 44
1x4 SSW8 Common	LM-STAR, TETS, C17	“	17	B 45
1x4 SSW8 Port1	“	“	17	B 46
1x4 SSW8 Port2	“	“	17	B 47
1x4 SSW8 Port3	LM-STAR	“	17	B 48
1x4 SSW8 Port4	LM-STAR	“	17	B 49

**Table A.46—1x4 switch (continued)**

CTI name	Legacy systems	Recommended attributes	Slot	Pin
1x4 SSW9 Common	LM-STAR, TETS, C17	“	17	C 40
1x4 SSW9 Port1	“	“	17	C 41
1x4 SSW9 Port2	“	“	17	C 42
1x4 SSW9 Port3	LM-STAR	“	17	C 43
1x4 SSW9 Port4	LM-STAR	“	17	C 44
1x4 SSW10 Common	LM-STAR, TETS, C17	“	17	D 40
1x4 SSW10 Port1	“	“	17	D 41
1x4 SSW10 Port2	“	“	17	D 42
1x4 SSW10 Port3	LM-STAR	“	17	D 43
1x4 SSW10 Port4	LM-STAR	“	17	D 44
1x4 SSW11 Common	LM-STAR, TETS, C17	“	18	A 1
1x4 SSW11 Port1	“	“	18	A 2
1x4 SSW11 Port2	“	“	18	A 3
1x4 SSW11 Port3	LM-STAR	“	18	A 4
1x4 SSW11 Port4	LM-STAR	“	18	A 5
1x4 SSW12 Common	LM-STAR, TETS, C17	“	18	A 6
1x4 SSW12 Port1	“	“	18	A 7
1x4 SSW12 Port2	“	“	18	A 8
1x4 SSW12 Port3	LM-STAR	“	18	A 9
1x4 SSW12 Port4	LM-STAR	“	18	A 10
1x4 SSW13 Common	“	“	18	A 11
1x4 SSW13 Port1	“	“	18	A 12
1x4 SSW13 Port2	“	“	18	A 13
1x4 SSW13 Port3	“	“	18	A 14
1x4 SSW13 Port4	“	“	18	A 15
1x4 SSW14 Common	“	“	18	B 1
1x4 SSW14 Port1	“	“	18	B 2
1x4 SSW14 Port2	“	“	18	B 3
1x4 SSW14 Port3	“	“	18	B 4
1x4 SSW14 Port4	“	“	18	B 5
1x4 SSW15 Common	“	“	18	B 6
1x4 SSW15 Port1	“	“	18	B 7
1x4 SSW15 Port2	“	“	18	B 8
1x4 SSW15 Port3	“	“	18	B 9
1x4 SSW15 Port4	“	“	18	B 10
1x4 SSW16 Common	“	“	18	B 11
1x4 SSW16 Port1	“	“	18	B 12
1x4 SSW16 Port2	“	“	18	B 13
1x4 SSW16 Port3	“	“	18	B 14
1x4 SSW16 Port4	“	“	18	B 15

Table A.47—1x2 switch

CTI name	Legacy systems	Recommended attributes	Slot	Pin
1x2 SSW 1 Common	IFTE, CASS, LM-STAR, TETS, IAIS, C17, RAF	Max voltage: 300 V Max current: 2 A Min switch speed: 15 ms Min breakdown voltage: 1000 Vdc Freq range: dc to 10 MHz Max switch path resistance (@ 1 mA): 1 Ω Min open switch isolation: 10 000 MΩ	3	A 1
1x2 SSW 1 Port1	IFTE, CASS, LM-STAR, IAIS, C17	“	3	A 2
1x2 SSW 1 Port2	IFTE, CASS, LM-STAR, IAIS, C17, TETS, RAF	“	3	A 3
1x2 SSW 2 Common	IFTE, CASS, LM-STAR, IAIS, C17, TETS, RAF	“	3	A 4
1x2 SSW 2 Port1	IFTE, CASS, LM-STAR, IAIS, C17	“	3	A 5
1x2 SSW 2 Port2	IFTE, CASS, LM-STAR, IAIS, C17, TETS, RAF	“	3	A 6
1x2 SSW 3 Common	IFTE, CASS, LM-STAR, IAIS, C17, TETS, RAF	“	3	A 7
1x2 SSW 3 Port1	IFTE, CASS, LM-STAR, IAIS, C17	“	3	A 8
1x2 SSW 3 Port2	IFTE, CASS, LM-STAR, IAIS, C17, TETS, RAF	“	3	A 9
1x2 SSW 4 Common	IFTE, CASS, LM-STAR, IAIS, C17, TETS, RAF	“	3	A 10
1x2 SSW 4 Port1	IFTE, CASS, LM-STAR, IAIS, C17	“	3	A 11
1x2 SSW 4 Port2	IFTE, CASS, LM-STAR, IAIS, C17, TETS, RAF	“	3	A 12
1x2 SSW 5 Common	IFTE, CASS, LM-STAR, IAIS, C17, TETS, RAF	“	3	A 13
1x2 SSW 5 Port1	IFTE, CASS, LM-STAR, IAIS, C17	“	3	A 14
1x2 SSW 5 Port2	IFTE, CASS, LM-STAR, IAIS, C17, TETS, RAF	“	3	A 15
1x2 SSW 6 Common	IFTE, CASS, LM-STAR, IAIS, C17, TETS, RAF	“	3	A 16
1x2 SSW 6 Port1	IFTE, CASS, LM-STAR, IAIS, C17	“	3	A 17
1x2 SSW 6 Port2	IFTE, CASS, LM-STAR, IAIS, C17, TETS, RAF	“	3	A 18
1x2 SSW 7 Common	IFTE, CASS, LM-STAR, IAIS, C17, TETS, RAF	“	3	A 19
1x2 SSW 7 Port1	IFTE, CASS, LM-STAR, IAIS, C17	“	3	A 20
1x2 SSW 7 Port2	IFTE, CASS, LM-STAR, IAIS, C17, TETS, RAF	“	3	A 21
1x2 SSW 8 Common	IFTE, CASS, LM-STAR, IAIS, C17, TETS, RAF	“	3	A 22

**Table A.47—1x2 switch (continued)**

CTI name	Legacy systems	Recommended attributes	Slot	Pin
1x2 SSW 8 Port1	IFTE, CASS, LM-STAR, IAIS, C17	“	3	A 23
1x2 SSW 8 Port2	IFTE, CASS, LM-STAR, IAIS, C17, TETS, RAF	“	3	A 24
1x2 SSW 9 Common	IFTE, CASS, LM-STAR, IAIS, C17, TETS, RAF	“	3	A 25
1x2 SSW 9 Port1	IFTE, CASS, LM-STAR, IAIS, C17	“	3	A 26
1x2 SSW 9 Port2	IFTE, CASS, LM-STAR, IAIS, C17, TETS, RAF	“	3	A 27
1x2 SSW 10 Common	IFTE, CASS, LM-STAR, IAIS, C17, TETS, RAF	“	3	A 28
1x2 SSW 10 Port1	IFTE, CASS, LM-STAR, IAIS, C17	“	3	A 29
1x2 SSW 10 Port2	IFTE, CASS, LM-STAR, IAIS, C17, TETS, RAF	“	3	A 30
1x2 SSW 11 Common	IFTE, CASS, LM-STAR, IAIS, C17, TETS, RAF	“	3	A 31
1x2 SSW 11 Port1	IFTE, CASS, LM-STAR, IAIS, C17	“	3	A 32
1x2 SSW 11 Port2	IFTE, CASS, LM-STAR, IAIS, C17, TETS, RAF	“	3	A 33
1x2 SSW 12 Common	IFTE, CASS, LM-STAR, IAIS, C17, TETS, RAF	“	3	A 34
1x2 SSW 12 Port1	IFTE, CASS, LM-STAR, IAIS, C17	“	3	A 35
1x2 SSW 12 Port2	IFTE, CASS, LM-STAR, IAIS, C17, TETS, RAF	“	3	A 36
1x2 SSW 13 Common	IFTE, CASS, LM-STAR, IAIS, C17, TETS, RAF	“	3	A 37
1x2 SSW 13 Port1	IFTE, CASS, LM-STAR, IAIS, C17	“	3	A 38
1x2 SSW 13 Port2	IFTE, CASS, LM-STAR, IAIS, C17, TETS, RAF	“	3	A 39
1x2 SSW 14 Common	IFTE, CASS, LM-STAR, IAIS, C17, TETS, RAF	“	3	A 40
1x2 SSW 14 Port1	IFTE, CASS, LM-STAR, IAIS, C17	“	3	A 41
1x2 SSW 14 Port2	IFTE, CASS, LM-STAR, IAIS, C17, TETS, RAF	“	3	A 42
1x2 SSW 15 Common	IFTE, CASS, LM-STAR, IAIS, C17, TETS, RAF	“	3	A 43
1x2 SSW 15 Port1	IFTE, CASS, LM-STAR, IAIS, C17	“	3	A 44
1x2 SSW 15 Port2	IFTE, CASS, LM-STAR, IAIS, C17, TETS, RAF	“	3	A 45
1x2 SSW 16 Common	IFTE, CASS, LM-STAR, IAIS, C17, TETS, RAF	“	3	B 1
1x2 SSW 16 Port1	IFTE, CASS, LM-STAR, IAIS, C17	“	3	B 2
1x2 SSW 16 Port2	IFTE, CASS, LM-STAR, IAIS, C17, TETS, RAF	“	3	B 3

Table A.47—1x2 switch (continued)

CTI name	Legacy systems	Recommended attributes	Slot	Pin
1x2 SSW 17 Common	IFTE, CASS, LM-STAR, IAIS, C17, TETS, RAF	“	3	B 4
1x2 SSW 17 Port1	IFTE, CASS, LM-STAR, IAIS, C17	“	3	B 5
1x2 SSW 17 Port2	IFTE, CASS, LM-STAR, IAIS, C17, TETS, RAF	“	3	B 6
1x2 SSW 18 Common	IFTE, CASS, LM-STAR, IAIS, C17, TETS, RAF	“	3	B 7
1x2 SSW 18 Port1	IFTE, CASS, LM-STAR, IAIS, C17	“	3	B 8
1x2 SSW 18 Port2	IFTE, CASS, LM-STAR, IAIS, C17, TETS, RAF	“	3	B 9
1x2 SSW 19 Common	IFTE, CASS, LM-STAR, IAIS, C17, TETS, RAF	“	3	B 10
1x2 SSW 19 Port1	IFTE, CASS, LM-STAR, IAIS, C17	“	3	B 11
1x2 SSW 19 Port2	IFTE, CASS, LM-STAR, IAIS, C17, TETS, RAF	“	3	B 12
1x2 SSW 20 Common	IFTE, CASS, LM-STAR, IAIS, C17, TETS, RAF	“	3	B 13
1x2 SSW 20 Port1	IFTE, CASS, LM-STAR, IAIS, C17	“	3	B 14
1x2 SSW 20 Port2	IFTE, CASS, LM-STAR, IAIS, C17, TETS, RAF	“	3	B 15
1x2 SSW 21 Common	IFTE, CASS, LM-STAR, IAIS, C17, TETS, RAF	“	3	B 16
1x2 SSW 21 Port1	IFTE, CASS, LM-STAR, IAIS, C17	“	3	B 17
1x2 SSW 21 Port2	IFTE, CASS, LM-STAR, IAIS, C17, TETS, RAF	“	3	B 18
1x2 SSW 22 Common	IFTE, CASS, LM-STAR, IAIS, C17, TETS, RAF	“	3	B 19
1x2 SSW 22 Port1	IFTE, CASS, LM-STAR, IAIS, C17	“	3	B 20
1x2 SSW 22 Port2	IFTE, CASS, LM-STAR, IAIS, C17, TETS, RAF	“	3	B 21
1x2 SSW 23 Common	IFTE, CASS, LM-STAR, IAIS, C17, TETS, RAF	“	3	B 22
1x2 SSW 23 Port1	IFTE, CASS, LM-STAR, IAIS, C17	“	3	B 23
1x2 SSW 23 Port2	IFTE, CASS, LM-STAR, IAIS, C17, TETS, RAF	“	3	B 24
1x2 SSW 24 Common	IFTE, CASS, LM-STAR, IAIS, C17, TETS, RAF	“	3	B 25
1x2 SSW 24 Port1	IFTE, CASS, LM-STAR, IAIS, C17	“	3	B 26
1x2 SSW 24 Port2	IFTE, CASS, LM-STAR, IAIS, C17, TETS, RAF	“	3	B 27
1x2 SSW 25 Common	IFTE, CASS, LM-STAR, IAIS, C17, TETS, RAF	“	3	B 28
1x2 SSW 25 Port1	IFTE, CASS, LM-STAR, IAIS, C17	“	3	B 29

**Table A.47—1x2 switch (continued)**

CTI name	Legacy systems	Recommended attributes	Slot	Pin
1x2 SSW 25 Port2	IFTE, CASS, LM-STAR, IAIS, C17, TETS, RAF	“	3	B 30
1x2 SSW 26 Common	IFTE, CASS, LM-STAR, IAIS, C17, TETS	“	3	B 31
1x2 SSW 26 Port1	IFTE, CASS, LM-STAR, IAIS, C17	“	3	B 32
1x2 SSW 26 Port2	IFTE, CASS, LM-STAR, IAIS, C17, TETS	“	3	B 33
1x2 SSW 27 Common	IFTE, CASS, LM-STAR, IAIS, C17, TETS	“	3	B 34
1x2 SSW 27 Port1	IFTE, CASS, LM-STAR, IAIS, C17	“	3	B 35
1x2 SSW 27 Port2	IFTE, CASS, LM-STAR, IAIS, C17, TETS	“	3	B 36
1x2 SSW 28 Common	IFTE, CASS, LM-STAR, IAIS, C17, TETS	“	3	B 37
1x2 SSW 28 Port1	IFTE, CASS, LM-STAR, IAIS, C17	“	3	B 38
1x2 SSW 28 Port2	IFTE, CASS, LM-STAR, IAIS, C17, TETS	“	3	B 39
1x2 SSW 29 Common	IFTE, CASS, LM-STAR, IAIS, C17, TETS	“	3	B 40
1x2 SSW 29 Port1	IFTE, CASS, LM-STAR, IAIS, C17	“	3	B 41
1x2 SSW 29 Port2	IFTE, CASS, LM-STAR, IAIS, C17, TETS	“	3	B 42
1x2 SSW 30 Common	IFTE, CASS, LM-STAR, IAIS, C17, TETS	“	3	B 43
1x2 SSW 30 Port1	IFTE, CASS, LM-STAR, IAIS, C17	“	3	B 44
1x2 SSW 30 Port2	IFTE, CASS, LM-STAR, IAIS, C17, TETS	“	3	B 45
1x2 SSW 31 Common	IFTE, CASS, LM-STAR, C17, TETS	“	3	C 1
1x2 SSW 31 Port1	IFTE, CASS, LM-STAR, C17	“	3	C 2
1x2 SSW 31 Port2	IFTE, CASS, LM-STAR, C17, TETS	“	3	C 3
1x2 SSW 32 Common	IFTE, CASS, LM-STAR, C17, TETS	“	3	C 4
1x2 SSW 32 Port1	IFTE, CASS, LM-STAR, C17	“	3	C 5
1x2 SSW 32 Port2	IFTE, CASS, LM-STAR, C17, TETS	“	3	C 6
1x2 SSW 33 Common	CASS, LM-STAR, TETS, C17	“	3	C 7
1x2 SSW 33 Port1	CASS, LM-STAR, C17,	“	3	C 8
1x2 SSW 33 Port2	CASS, LM-STAR, TETS, C17	“	3	C 9
1x2 SSW 34 Common	CASS, LM-STAR, TETS, C17	“	3	C 10



Table A.47—1x2 switch (continued)

CTI name	Legacy systems	Recommended attributes	Slot	Pin
1x2 SSW 34 Port1	CASS, LM-STAR, C17	“	3	C 11
1x2 SSW 34 Port2	CASS, LM-STAR, TETS, C17	“	3	C 12
1x2 SSW 35 Common	CASS, LM-STAR, TETS, C17	“	3	C 13
1x2 SSW 35 Port1	CASS, LM-STAR, C17	“	3	C 14
1x2 SSW 35 Port2	CASS, LM-STAR, TETS, C17	“	3	C 15
1x2 SSW 36 Common	CASS, LM-STAR, TETS, C17	“	3	C 16
1x2 SSW 36 Port1	CASS, LM-STAR, C17	“	3	C 17
1x2 SSW 36 Port2	CASS, LM-STAR, TETS, C17	“	3	C 18
1x2 SSW 37 Common	CASS, LM-STAR, TETS, C17	“	3	C 19
1x2 SSW 37 Port1	CASS, LM-STAR, C17	“	3	C 20
1x2 SSW 37 Port2	CASS, LM-STAR, TETS, C17	“	3	C 21
1x2 SSW 38 Common	CASS, LM-STAR, TETS, C17	“	3	C 22
1x2 SSW 38 Port1	CASS, LM-STAR, C17	“	3	C 23
1x2 SSW 38 Port2	CASS, LM-STAR, TETS, C17	“	3	C 24
1x2 SSW 39 Common	CASS, LM-STAR, TETS, C17, RAF	“	3	C 25
1x2 SSW 39 Port1	CASS, LM-STAR, C17	“	3	C 26
1x2 SSW 39 Port2	CASS, LM-STAR, TETS, C17, RAF	“	3	C 27
1x2 SSW 40 Common	CASS, LM-STAR, TETS, C17, RAF	“	3	C 28
1x2 SSW 40 Port1	CASS, LM-STAR, C17	“	3	C 29
1x2 SSW 40 Port2	CASS, LM-STAR, TETS, C17, RAF	“	3	C 30
1x2 SSW 41 Common	CASS, LM-STAR, TETS, C17, RAF	“	3	C 31
1x2 SSW 41 Port1	CASS, LM-STAR, C17	“	3	C 32
1x2 SSW 41 Port2	CASS, LM-STAR, TETS, C17, RAF	“	3	C 33
1x2 SSW 42 Common	CASS, LM-STAR, TETS, C17	“	3	C 34
1x2 SSW 42 Port1	CASS, LM-STAR, C17	“	3	C 35
1x2 SSW 42 Port2	CASS, LM-STAR, TETS, C17	“	3	C 36
1x2 SSW 43 Common	CASS, LM-STAR, TETS, C17	“	3	C 37
1x2 SSW 43 Port1	CASS, LM-STAR, C17	“	3	C 38
1x2 SSW 43 Port2	CASS, LM-STAR, TETS, C17	“	3	C 39
1x2 SSW 44 Common	CASS, LM-STAR, TETS, C17	“	3	C 40
1x2 SSW 44 Port1	CASS, LM-STAR, C17	“	3	C 41
1x2 SSW 44 Port2	CASS, LM-STAR, TETS, C17	“	3	C 42

**Table A.47—1x2 switch (continued)**

CTI name	Legacy systems	Recommended attributes	Slot	Pin
1x2 SSW 45 Common	CASS, LM-STAR, TETS, C17	“	3	D 1
1x2 SSW 45 Port1	CASS, LM-STAR, C17	“	3	D 2
1x2 SSW 45 Port2	CASS, LM-STAR, TETS, C17	“	3	D 3
1x2 SSW 46 Common	CASS, LM-STAR, TETS, C17	“	3	D 4
1x2 SSW 46 Port1	CASS, LM-STAR, C17	“	3	D 5
1x2 SSW 46 Port2	CASS, LM-STAR, TETS, C17	“	3	D 6
1x2 SSW 47 Common	CASS, LM-STAR, TETS, C17	“	3	D 7
1x2 SSW 47 Port1	CASS, LM-STAR, C17	“	3	D 8
1x2 SSW 47 Port2	CASS, LM-STAR, TETS, C17	“	3	D 9
1x2 SSW 48 Common	CASS, LM-STAR, TETS, C17	“	3	D 10
1x2 SSW 48 Port1	CASS, LM-STAR, C17	“	3	D 11
1x2 SSW 48 Port2	CASS, LM-STAR, TETS, C17	“	3	D 12
1x2 SSW 49 Common	CASS, LM-STAR, TETS, C17	“	3	D 13
1x2 SSW 49 Port1	CASS, LM-STAR, C17	“	3	D 14
1x2 SSW 49 Port2	CASS, LM-STAR, TETS, C17	“	3	D 15
1x2 SSW 50 Common	CASS, LM-STAR, TETS, C17	“	3	D 16
1x2 SSW 50 Port1	CASS, LM-STAR, C17	“	3	D 17
1x2 SSW 50 Port2	CASS, LM-STAR, TETS, C17	“	3	D 18
1x2 SSW 51 Common	CASS, LM-STAR, ESTS, C17, TETS,	Max current: 4 A Min switch speed: 15 ms Min breakdown voltage: 1000 Vdc Freq range: dc to 1 MHz Max switch path resistance (@ 1 mA): 1 Ω Min open switch isolation: 10 000 MΩ	3	D 19
1x2 SSW 51 Port1	CASS, LM-STAR, ESTS, C17	“	3	D 20
1x2 SSW 51 Port2	CASS, LM-STAR, ESTS, C17, TETS,	“	3	D 21
1x2 SSW 52 Common	CASS, LM-STAR, ESTS, C17, TETS,	“	3	D 22
1x2 SSW 52 Port1	CASS, LM-STAR, ESTS, C17	“	3	D 23
1x2 SSW 52 Port2	CASS, LM-STAR, ESTS, C17, TETS,	“	3	D 24
1x2 SSW 53 Common	CASS, LM-STAR, ESTS, C17, TETS,	“	3	D 25
1x2 SSW 53 Port1	CASS, LM-STAR, ESTS, C17	“	3	D 26
1x2 SSW 53 Port2	CASS, LM-STAR, ESTS, C17, TETS,	“	3	D 27

**Table A.47—1x2 switch (continued)**

CTI name	Legacy systems	Recommended attributes	Slot	Pin
1x2 SSW 54 Common	CASS, LM-STAR, ESTS, C17, TETS,	“	3	D 28
1x2 SSW 54 Port1	CASS, LM-STAR, ESTS, C17	“	3	D 29
1x2 SSW 54 Port2	CASS, LM-STAR, ESTS, C17, TETS,	“	3	D 30
1x2 SSW 55 Common	CASS, LM-STAR, ESTS, C17, TETS,	“	3	D 31
1x2 SSW 55 Port1	CASS, LM-STAR, ESTS, C17	“	3	D 32
1x2 SSW 55 Port2	CASS, LM-STAR, ESTS, C17, TETS,	“	3	D 33
1x2 SSW 56 Common	CASS, LM-STAR, ESTS, C17, TETS,	“	3	D 34
1x2 SSW 56 Port1	CASS, LM-STAR, ESTS, C17	“	3	D 35
1x2 SSW 56 Port2	CASS, LM-STAR, ESTS, C17, TETS,	“	3	D 36
1x2 SSW 57 Common	CASS, LM-STAR, ESTS, C17, TETS,	“	3	D 37
1x2 SSW 57 Port1	CASS, LM-STAR, ESTS, C17	“	3	D 38
1x2 SSW 57 Port2	CASS, LM-STAR, ESTS, C17, TETS,	“	3	D 39
1x2 SSW 58 Common	CASS, LM-STAR, ESTS, C17, TETS,	“	3	D 40
1x2 SSW 58 Port1	CASS, LM-STAR, ESTS, C17	“	3	D 41
1x2 SSW 58 Port2	CASS, LM-STAR, ESTS, C17, TETS	“	3	D 42
1x2 SSW 59 Common	CASS, LM-STAR, ESTS, TETS, C17	“	19	A 17
1x2 SSW 59 Port1	CASS, LM-STAR, ESTS, C17	“	19	A 18
1x2 SSW 59 Port2	CASS, LM-STAR, ESTS, TETS, C17	“	19	A 19
1x2 SSW 60 Common	CASS, LM-STAR, ESTS, TETS, C17	“	19	A 20
1x2 SSW 60 Port1	CASS, LM-STAR, ESTS, C17	“	19	A 21
1x2 SSW 60 Port2	CASS, LM-STAR, ESTS, TETS, C17	“	19	A 22
1x2 SSW 61 Common	CASS, LM-STAR, ESTS, TETS, C17	“	19	A 23
1x2 SSW 61 Port1	CASS, LM-STAR, ESTS, C17	“	19	A 24
1x2 SSW 61 Port2	CASS, LM-STAR, ESTS, TETS, C17	“	19	A 25
1x2 SSW 62 Common	CASS, LM-STAR, ESTS, TETS, C17	“	19	A 26
1x2 SSW 62 Port1	CASS, LM-STAR, ESTS, C17	“	19	A 27

**Table A.47—1x2 switch (continued)**

CTI name	Legacy systems	Recommended attributes	Slot	Pin
1x2 SSW 62 Port2	CASS, LM-STAR, ESTS, TETS, C17	“	19	A 28
1x2 SSW 63 Common	CASS, LM-STAR, ESTS, TETS, C17	“	19	A 29
1x2 SSW 63 Port1	CASS, LM-STAR, ESTS, C17	“	19	A 30
1x2 SSW 63 Port2	CASS, LM-STAR, ESTS, TETS, C17	“	19	A 31
1x2 SSW 64 Common	CASS, LM-STAR, ESTS, TETS, C17	“	19	A 32
1x2 SSW 64 Port1	CASS, LM-STAR, ESTS, C17	“	19	A 33
1x2 SSW 64 Port2	CASS, LM-STAR, ESTS, TETS, C17	“	19	A 34
1x2 SSW 65 Common	CASS, LM-STAR, ESTS, TETS, C17	“	19	A 35
1x2 SSW 65 Port1	CASS, LM-STAR, ESTS, C17	“	19	A 36
1x2 SSW 65 Port2	CASS, LM-STAR, ESTS, TETS, C17	“	19	A 37
1x2 SSW 66 Common	CASS, LM-STAR, ESTS, TETS, C17	“	19	A 38
1x2 SSW 66 Port1	CASS, LM-STAR, ESTS, C17	“	19	A 39
1x2 SSW 66 Port2	CASS, LM-STAR, ESTS, TETS, C17	“	19	A 40
1x2 SSW 67 Common	CASS, LM-STAR, ESTS, TETS, C17	“	19	A 41
1x2 SSW 67 Port1	CASS, LM-STAR, ESTS, C17	“	19	A 42
1x2 SSW 67 Port2	CASS, LM-STAR, ESTS, TETS, C17	“	19	A 43
1x2 SSW 68 Common	CASS, LM-STAR, ESTS, TETS, C17	“	19	A 44
1x2 SSW 68 Port1	CASS, LM-STAR, ESTS, C17	“	19	A 45
1x2 SSW 68 Port2	CASS, LM-STAR, ESTS, TETS, C17	“	19	A 46
1x2 SSW 69 Common	CASS, LM-STAR, ESTS, TETS, C17	“	19	A 47
1x2 SSW 69 Port1	CASS, LM-STAR, ESTS, C17	“	19	A 48
1x2 SSW 69 Port2	CASS, LM-STAR, ESTS, TETS, C17	“	19	A 49
1x2 SSW 70 Common	CASS, LM-STAR, ESTS, TETS, C17	“	19	B 17
1x2 SSW 70 Port1	CASS, LM-STAR, ESTS, C17	“	19	B 18
1x2 SSW 70 Port2	CASS, LM-STAR, ESTS, C17, TETS	“	19	B 19
1x2 SSW 71 Common	LM-STAR, TETS, ESTS, C17	“	19	B 20
1x2 SSW 71 Port1	LM-STAR, ESTS, C17	“	19	B 21

**Table A.47—1x2 switch (continued)**

CTI name	Legacy systems	Recommended attributes	Slot	Pin
1x2 SSW 71 Port2	LM-STAR, ESTS, C17, TETS	“	19	B 22
1x2 SSW 72 Common	LM-STAR, ESTS, C17, TETS	“	19	B 23
1x2 SSW 72 Port1	LM-STAR, ESTS, C17	“	19	B 24
1x2 SSW 72 Port2	LM-STAR, ESTS, C17, TETS	“	19	B 25
1x2 SSW 73 Common	LM-STAR, ESTS, C17, TETS	“	19	B 26
1x2 SSW 73 Port1	LM-STAR, ESTS, C17	“	19	B 27
1x2 SSW 73 Port2	LM-STAR, ESTS, C17, TETS	“	19	B 28
1x2 SSW 74 Common	LM-STAR, ESTS, C17, TETS	“	19	B 29
1x2 SSW 74 Port1	LM-STAR, ESTS, C17	“	19	B 30
1x2 SSW 74 Port2	LM-STAR, ESTS, C17, TETS	“	19	B 31
1x2 SSW 75 Common	LM-STAR, ESTS, C17, TETS	“	19	B 32
1x2 SSW 75 Port1	LM-STAR, ESTS, C17	“	19	B 33
1x2 SSW 75 Port2	LM-STAR, ESTS, C17, TETS	“	19	B 34
1x2 SSW 76 Common	LM-STAR, ESTS, C17, TETS	“	19	B 35
1x2 SSW 76 Port1	LM-STAR, ESTS, C17	“	19	B 36
1x2 SSW 76 Port2	LM-STAR, ESTS, C17, TETS	“	19	B 37
1x2 SSW 77 Common	LM-STAR, ESTS, C17, TETS	“	19	B 38
1x2 SSW 77 Port1	LM-STAR, ESTS, C17	“	19	B 39
1x2 SSW 77 Port2	LM-STAR, ESTS, C17, TETS	“	19	B 40
1x2 SSW 78 Common	LM-STAR, ESTS, C17, TETS	“	19	B 41
1x2 SSW 78 Port1	LM-STAR, ESTS, C17	“	19	B 42
1x2 SSW 78 Port2	LM-STAR, ESTS, C17, TETS	“	19	B 43
1x2 SSW 79 Common	LM-STAR, ESTS, C17, TETS	“	19	B 44
1x2 SSW 79 Port1	LM-STAR, ESTS, C17	“	19	B 45
1x2 SSW 79 Port2	LM-STAR, ESTS, C17, TETS	“	19	B 46
1x2 SSW 80 Common	LM-STAR, ESTS, C17, TETS	“	19	B 47
1x2 SSW 80 Port1	LM-STAR, ESTS, C17	“	19	B 48
1x2 SSW 80 Port2	LM-STAR, ESTS, C17, TETS	“	19	B 49
1x2 SSW 81 Common	IFTE, LM-STAR, ESTS, TETS, C17	“	19	C 17
1x2 SSW 81 Port1	LM-STAR, ESTS, C17	“	19	C 18
1x2 SSW 81 Port2	IFTE, LM-STAR, ESTS, TETS, C17	“	19	C 19
1x2 SSW 82 Common	IFTE, LM-STAR, ESTS, TETS, C17	“	19	C 20

**Table A.47—1x2 switch (continued)**

CTI name	Legacy systems	Recommended attributes	Slot	Pin
1x2 SSW 82 Port1	LM-STAR, ESTS, C17	“	19	C 21
1x2 SSW 82 Port2	IFTE, LM-STAR, ESTS, TETS, C17	“	19	C 22
1x2 SSW 83 Common	IFTE, LM-STAR, TETS, C17	“	19	C 23
1x2 SSW 83 Port1	LM-STAR, C17	“	19	C 24
1x2 SSW 83 Port2	IFTE, LM-STAR, TETS, C17	“	19	C 25
1x2 SSW 84 Common	IFTE, LM-STAR, TETS, C17	“	19	C 26
1x2 SSW 84 Port1	LM-STAR, C17	“	19	C 27
1x2 SSW 84 Port2	IFTE, LM-STAR, TETS, C17	“	19	C 28
1x2 SSW 85 Common	IFTE, LM-STAR, TETS, C17	“	19	C 29
1x2 SSW 85 Port1	LM-STAR, C17	“	19	C 30
1x2 SSW 85 Port2	IFTE, LM-STAR, TETS, C17	“	19	C 31
1x2 SSW 86 Common	IFTE, LM-STAR, TETS, C17	“	19	C 32
1x2 SSW 86 Port1	LM-STAR, C17	“	19	C 33
1x2 SSW 86 Port2	IFTE, LM-STAR, TETS, C17	“	19	C 34
1x2 SSW 87 Common	IFTE, LM-STAR, TETS, C17	“	19	C 35
1x2 SSW 87 Port1	LM-STAR, C17	“	19	C 36
1x2 SSW 87 Port2	IFTE, LM-STAR, TETS, C17	“	19	C 37
1x2 SSW 88 Common	IFTE, LM-STAR, TETS, C17	“	19	C 38
1x2 SSW 88 Port1	LM-STAR, C17	“	19	C 39
1x2 SSW 88 Port2	IFTE, LM-STAR, TETS, C17	“	19	C 40
1x2 SSW 89 Common	IFTE, LM-STAR, TETS, C17	“	19	C 41
1x2 SSW 89 Port1	LM-STAR, C17	“	19	C 42
1x2 SSW 89 Port2	IFTE, LM-STAR, TETS, C17	“	19	C 43
1x2 SSW 90 Common	IFTE, LM-STAR, TETS, C17	“	19	C 44
1x2 SSW 90 Port1	LM-STAR, C17	“	19	C 45
1x2 SSW 90 Port2	IFTE, LM-STAR, TETS, C17	“	19	C 46
1x2 SSW 91 Common	IFTE, LM-STAR, TETS, C17	“	19	D 17
1x2 SSW 91 Port1	LM-STAR, C17	“	19	D 18
1x2 SSW 91 Port2	IFTE, LM-STAR, TETS, C17	“	19	D 19
1x2 SSW 92 Common	IFTE, LM-STAR, TETS, C17	“	19	D 20
1x2 SSW 92 Port1	LM-STAR, C17	“	19	D 21
1x2 SSW 92 Port2	IFTE, LM-STAR, TETS, C17	“	19	D 22
1x2 SSW 93 Common	IFTE, LM-STAR, TETS, C17	“	19	D 23

**Table A.47—1x2 switch (continued)**

CTI name	Legacy systems	Recommended attributes	Slot	Pin
1x2 SSW 93 Port1	LM-STAR, C17	“	19	D 24
1x2 SSW 93 Port2	IFTE, LM-STAR, TETS, C17	“	19	D 25
1x2 SSW 94 Common	IFTE, LM-STAR, TETS, C17	“	19	D 26
1x2 SSW 94 Port1	LM-STAR, C17	“	19	D 27
1x2 SSW 94 Port2	IFTE, LM-STAR, TETS, C17	“	19	D 28
1x2 SSW 95 Common	IFTE, LM-STAR, TETS, C17	“	19	D 29
1x2 SSW 95 Port1	LM-STAR, C17	“	19	D 30
1x2 SSW 95 Port2	IFTE, LM-STAR, TETS, C17	“	19	D 31
1x2 SSW 96 Common	IFTE, LM-STAR, TETS, C17	“	19	D 32
1x2 SSW 96 Port1	LM-STAR, C17	“	19	D 33
1x2 SSW 96 Port2	IFTE, LM-STAR, TETS, C17	“	19	D 34
1x2 SSW 97 Common	IFTE, LM-STAR, C17	“	19	D 35
1x2 SSW 97 Port1	LM-STAR, C17	“	19	D 36
1x2 SSW 97 Port2	IFTE, LM-STAR, C17	“	19	D 37
1x2 SSW 98 Common	IFTE, LM-STAR, C17	“	19	D 38
1x2 SSW 98 Port1	LM-STAR, C17	“	19	D 39
1x2 SSW 98 Port2	IFTE, LM-STAR, C17	“	19	D 40
1x2 SSW 99 Common	LM-STAR, C17	“	19	D 41
1x2 SSW 99 Port1	“	“	19	D 42
1x2 SSW 99 Port2	“	“	19	D 43
1x2 SSW 100 Common	“	“	19	D 44
1x2 SSW 100 Port1	“	“	19	D 45
1x2 SSW 100 Port2	“	“	19	D 46

**Table A.48—ETE ground**

CTI name	Legacy systems	Recommended attributes	Slot	Pin
ETE GND 1	N/A	Maximum voltage: 300 Vdc Maximum current: 5 A	3	D50
ETE GND 2	“	“	7	D50
ETE GND 3	“	“	14	D50

**Table A.49—Frequency standard**

CTI name	Legacy systems	Recommended attributes	Slot	Pin
100 MHz ref	LM-STAR	Max freq: 100 MHz Impedance: 50 Ω Max voltage: 1.6 V Stability: 10 ppm/year	21,22	A 12
10 MHz Ref	IFTE, CASS, LM-STAR, IAIS	Max freq: 10 MHz Impedance: 50 Ω Max voltage: 1.6 V Stability: 10 ppm/year	21,22	B 12

**Table A.50—System trigger**

CTI name	Legacy systems	Recommended attributes	Slot	Pin
System Trigger STA System Ext. Input	CASS, LM-STAR, IAIS	Max voltage: ±5 V Max current: 100 mA Min pulse width: 3 ns	9	D 38
System Trigger Shield	“	“	9	C 38
System Trigger STA Sys Trigger A+	CASS, LM-STAR, IAIS	Max voltage: Diff ECL Max current: 50 mA Min period: 10 ns	9	C 37
System Trigger Shield STA Sys Trigger A-	“	“	9	C 36
System Trigger STA Sys Trig A Shield	CASS, LM-STAR	“	9	C 35
System Trigger STA Sys Trig B+	CASS, LM-STAR, IAIS	“	9	D 36
System Trigger STA Sys Trig B-	“	“	9	D 37
System Trigger STA Sys Trig B Shield	CASS, LM-STAR	“	9	D 35



**Table A.51—Interrupts, interlocks, and shutdown**

CTI name	Legacy systems	Recommended attributes	Slot	Pin
System ID 1	N/A	TTL/GND	18	A 37
System ID 2	N/A	“	18	A 38
System ID 3	N/A	“	18	A 39
System ID 4	N/A	“	18	A 40
System ID 5	N/A	“	18	B 37
System ID 6	N/A	“	18	B 38
System ID 7	N/A	“	18	B 39
System ID 8	N/A	“	18	B 40
System ID 9	N/A	“	18	C 40
UUT Interrupt 1	CASS, LM-STAR, IAIS, RAF	Max voltage: 32 V Current: 21 mA	28	A 34
UUT Interrupt 2	CASS, LM-STAR, IAIS	“	28	A 35
UUT Interrupt 3	“	“	28	A 36
UUT Interrupt 4	“	“	28	A 37
UUT Interrupt 5	“	“	28	B 34
UUT Interrupt 6	“	“	28	B 35
UUT Interrupt 7	“	“	28	B 36
UUT Interrupt 8	“	“	28	B 37
UUT Interrupt 9	“	“	28	C 34
UUT Interrupt 10	“	“	28	C 35
UUT Interrupt Rtn1	CASS, LM-STAR, IAIS, RAF	“	28	C 36
UUT Interrupt Rtn2	LM-STAR, IAIS	“	28	C 37
UUT Intlk	CASS, LM-STAR, IAIS	J28-D34 and J28-D35 shall be shorted together by the connection of a UUT to the ID, and the “.UUTINTLK” global variable should be set in the TPS software. If the UUT or ID is removed during testing and if the .UUTINTLK global variable is set by the TPS, UUT power and stimulus is removed in accordance with either the default or TPS defined sequential shutdown file, and TPS execution is aborted.	28	D 34
UUT Intlk Rtn	LM-STAR, IAIS		28	D 35
Interlock ID Intlk 1		J7-A50 and J7-B50 shall be shorted together in the ID, and the “.IDOPEN” global variable should be set in the TPS software. If the ID is opened during testing and if the .IDOPEN global variable is set by the TPS, all UUT power and stimulus is removed in accordance with either the default or TPS defined sequential shutdown file, and TPS execution is aborted.	7	A 50
Interlock ID Intlk 1 Rtn			7	B 50
GPI Interlock N.O	CASS, TETS		3	D50
GPI Interlock N.C	CASS, TETS		3	C50

**Table A.51—Interrupts, interlocks, and shutdown (continued)**

CTI name	Legacy systems	Recommended attributes	Slot	Pin
Interlock ID Intlk 2		J3-C43 and J3-D43 shall be shorted together in the ID, and the “.IDOPEN” global variable should be set in the TPS software. If the ID is opened during testing and if the .IDOPEN global variable is set by the TPS, all UUT power and stimulus is removed in accordance with either the default or TPS defined sequential shutdown file, and TPS execution is aborted.	3	C 43
Interlock ID Intlk 2 Rtn			3	D 43
Interlock ID Intlk 3		J12-D50 and J12-C50 shall be shorted together in the ID, and the “.IDOPEN” global variable should be set in the TPS software. If the ID is opened during testing and if the .IDOPEN global variable is set by the TPS, all UUT power and stimulus is removed in accordance with either the default or TPS defined sequential shutdown file, and TPS execution is aborted.	12	D 50
Interlock ID Intlk 3 Rtn			12	C 50
Interlock ID Intlk 4	CASS, LM-STAR, IAIS	J28-D38 and J28-C38 shall be shorted together in the ID, and the “.IDOPEN” global variable should be set in the TPS software. If the ID is opened during testing and if the .IDOPEN global variable is set by the TPS, all UUT power and stimulus is removed in accordance with either the default or TPS defined sequential shutdown file, and TPS execution is aborted.	28	D 38
Interlock ID Intlk 4 Rtn	LM-STAR, ISIA		28	C 38
UUT Shut Dwn	CASS, LM-STAR, IAIS	J28-D36 and J28-D37 should be in parallel to the “EMER OFF - UUT” button. When shorted, all power and stimulus is removed from the UUT in accordance with either the default or TPS defined sequential shutdown file. Also, the UUT test program is aborted and removed from the test queue.	28	D 36
UUT Shutdwn Rtn	CASS, LM-STAR, IAIS		28	D 37

**Table A.52—Safety ground**

CTI name	Legacy systems	Recommended attributes	Slot	Pin
Safety GND	IFTE, CASS, ESTS	Voltage: 55 V Current: 20 A	6	A 20
Safety GND	IFTE, CASS	Voltage: 55 V Current: 20 A	6	C 20

## Annex B

(informative)

### Bibliography

[B1] Automatic Test System Critical Interfaces Report, Release 1, 9/30/96, <http://grouper.ieee.org/groups/scc20/HiWG/CIWG%20Report.doc>.

[B2] DoD Instruction 5000.2, “Operation of the Defense Acquisition System,” May 12, 2003.<sup>12</sup>

[B3] EIA/ECA-310-E (2005), Cabinets, Racks, Panels, and Associated Equipment.<sup>13</sup>

[B4] IEEE/ASTM SI 10<sup>TM</sup>-2002, American National Standard for Use of the International System of Units (SI): The Modern Metric System.<sup>14, 15</sup>

[B5] IEEE 100<sup>TM</sup>, *The Authoritative Dictionary of IEEE Standards Terms*, Seventh Edition. New York, Institute of Electrical Electronics Engineers, Inc.

[B6] IEEE Std 260.1<sup>TM</sup>-2004, IEEE Standard Letter Symbols for Units of Measurement (SI Units, Customary Inch-Pound Units, and Certain Other Units).

[B7] IEEE Std 260.3<sup>TM</sup>-1993 (Reaff 2006), IEEE Standard for Mathematical Signs and Symbols for Use in Physical Sciences and Technology.

[B8] IEEE Std 280<sup>TM</sup>-1982, IEEE Standard Letter Symbols for Quantities Used in Electrical Science and Electrical Engineering.

[B9] IEEE Std 315<sup>TM</sup>-1975 (Reaff 1993), IEEE Standard Graphic Symbols for Electrical and Electronics Diagrams (Including Reference Designation Letters).

[B10] IEEE Std 945<sup>TM</sup>-1984 (Reaff 2002), IEEE Recommended Practice for Preferred Metric Units for Use in Electrical and Electronics Science and Technology.

[B11] IEEE Std 991<sup>TM</sup>-1986 (Reaff 1994), IEEE Standard for Logic Circuit Diagrams.

[B12] IEEE Std 1014<sup>TM</sup>-1987 (Reaff 2008); IEEE Standard for Versatile Backplane Bus: VMEBUS.

[B13] IEEE Std 1149.1<sup>TM</sup>-2001 (Reaff 2008), IEEE Standard Access Port and Boundary-Scan Architecture.

[B14] *IEEE-SA Standards Board Bylaws*. New York: Institute of Electrical and Electronics Engineers, Inc.

[B15] *IEEE-SA Standards Board Operations Manual*, New York: Institute of Electrical and Electronics Engineers, Inc.

[B16] *IEEE-SA Standards Companion*. New York: Institute of Electrical and Electronics Engineers, Inc.

<sup>12</sup> DoD Instruction available from Defense Technical Information Center (DTIC) (<http://www.dtic.mil/whs/directives/index.html>).

<sup>13</sup> EIA/ECA publications are available from Global Engineering Documents, 15 Inverness Way East, Englewood, Colorado 80112, USA (<http://global.ihs.com/>).

<sup>14</sup> IEEE publications are available from the Institute of Electrical and Electronics Engineers Inc., 445 Hoes Lane, Piscataway, NJ 08854, USA (<http://standards.ieee.org/>).

<sup>15</sup> The IEEE standards or products referred to in this annex are trademarks owned by the Institute of Electrical and Electronics Engineers, Incorporated.

[B17] *IEEE Standards Style Manual*. New York: Institute of Electrical and Electronics Engineers, Inc.

[B18] Joint Service Automatic Test Systems Research and Development Integrated Product Team (ARI), government/industry Critical Interfaces Working Group; USAF-CIWG Contract Report, Washington, DC, 6/1/98.

[B19] MIL-C-83733, Rectangular Rack and Panel Connectors.<sup>16</sup>

[B20] MIL-DTL-55302/179-180, Connectors, Printed Circuit Subassembly and Accessories.

[B21] MIL-HDBK-217, Reliability Prediction of Electronic Equipment.

[B22] MIL-PRF-28800, General Specification for Test Equipment for Use with Electrical and Electronic Equipment.

---

<sup>16</sup> MIL publications are available from Customer Service, Defense Printing Service, 700 Robbins Ave., Bldg. 4D, Philadelphia, PA 19111-5094 and SAI Global, 610 Winters Ave, Paramus, NJ 07652, <http://www.saiglobal.com/>.

**Annex C**

(informative)

**IEEE List of Participants**

At the time this standard was submitted to the IEEE-SA Standards Board for approval, the Hardware Interfaces Working Group had the following membership:

**David Droste**, *Co-Chair*

**Michael Stora**, *Co-Chair*

Larry Boykin  
Malcolm Brown  
Kahn Chun  
Anthony Estrada  
Anthony Geneva  
Chris Gorringer  
David Heck  
Orman (Bob) Horton  
Ashley Hulme  
Mark Kaufman  
John Knowles

Harry Lambert  
James Langlois  
William Maciejewski  
Stephen Mann  
Alex Meloni  
Scott Misha  
Ion Neag  
Kenney Nordstrom  
Leslie Orlidge  
Richard Patrick

Ted Ronnenburg  
William Ross  
Howard Savage  
Mike Seavey  
P. A. Sedberry, Jr.  
John Sheppard  
Roger Sowada  
Rob Spinner  
Mario Tobias  
Timothy Wilmering  
Dave Wilson

The following members of the individual balloting committee voted on this standard. Balloters may have voted for approval, disapproval, or abstention.

Malcom Brown  
Keith Chow  
Tommy Cooper  
David Droste  
James Dumser  
William Frank  
Anthony Geneva  
Chris Gorringer  
Randall Groves

Werner Hoelzl  
James Langlois  
William Maciejewski  
Scott Misha  
Prajit Nair  
Michael S. Newman  
Leslie Orlidge  
Richard Patrick

Ulrich Pohl  
Mike Seavey  
P. A. Sedberry, Jr.  
James E. Smith  
Joseph Stanco  
Michael Stora  
Walter Struppler  
Ronald Taylor  
Robert White

When the IEEE-SA Standards Board approved this standard on 26 September 2008, it had the following membership:

**Robert M. Grow**, *Chair*  
**Thomas Prevost**, *Vice Chair*  
**Steve M. Mills**, *Past Chair*  
**Judith Gorman**, *Secretary*

Victor Berman  
Richard DeBlasio  
Andy Drozd  
Mark Epstein  
Alexander Gelman  
William R. Goldbach  
Arnold M. Greenspan  
Kenneth S. Hanus

Jim Hughes  
Richard H. Hulett  
Young Kyun Kim  
Joseph L. Koepfinger\*  
John Kulick  
David J. Law  
Glenn Parsons

Ronald C. Petersen  
Chuck Powers  
Narayanan Ramachandran  
Jon Walter Rosdahl  
Anne-Marie Sahazizian  
Malcolm V. Thaden  
Howard L. Wolfman  
Don Wright

\*Member Emeritus

Also included are the following nonvoting IEEE-SA Standards Board liaisons:

Satish K. Aggarwal, *NRC Representative*  
Michael H. Kelley, *NIST Representative*

Jennie Steinhagen  
*IEEE Standards Program Manager, Document Development*

Kathryn Cush  
*IEEE Standards Program Manager, Technical Program Development*



# British Standards Institution (BSI)

BSI is the national body responsible for preparing British Standards and other standards-related publications, information and services.

BSI is incorporated by Royal Charter. British Standards and other standardization products are published by BSI Standards Limited.

## About us

We bring together business, industry, government, consumers, innovators and others to shape their combined experience and expertise into standards-based solutions.

The knowledge embodied in our standards has been carefully assembled in a dependable format and refined through our open consultation process. Organizations of all sizes and across all sectors choose standards to help them achieve their goals.

## Information on standards

We can provide you with the knowledge that your organization needs to succeed. Find out more about British Standards by visiting our website at [bsigroup.com/standards](http://bsigroup.com/standards) or contacting our Customer Services team or Knowledge Centre.

## Buying standards

You can buy and download PDF versions of BSI publications, including British and adopted European and international standards, through our website at [bsigroup.com/shop](http://bsigroup.com/shop), where hard copies can also be purchased.

If you need international and foreign standards from other Standards Development Organizations, hard copies can be ordered from our Customer Services team.

## Subscriptions

Our range of subscription services are designed to make using standards easier for you. For further information on our subscription products go to [bsigroup.com/subscriptions](http://bsigroup.com/subscriptions).

With **British Standards Online (BSOL)** you'll have instant access to over 55,000 British and adopted European and international standards from your desktop. It's available 24/7 and is refreshed daily so you'll always be up to date.

You can keep in touch with standards developments and receive substantial discounts on the purchase price of standards, both in single copy and subscription format, by becoming a **BSI Subscribing Member**.

**PLUS** is an updating service exclusive to BSI Subscribing Members. You will automatically receive the latest hard copy of your standards when they're revised or replaced.

To find out more about becoming a BSI Subscribing Member and the benefits of membership, please visit [bsigroup.com/shop](http://bsigroup.com/shop).

With a **Multi-User Network Licence (MUNL)** you are able to host standards publications on your intranet. Licences can cover as few or as many users as you wish. With updates supplied as soon as they're available, you can be sure your documentation is current. For further information, email [bsmusales@bsigroup.com](mailto:bsmusales@bsigroup.com).

## Revisions

Our British Standards and other publications are updated by amendment or revision.

We continually improve the quality of our products and services to benefit your business. If you find an inaccuracy or ambiguity within a British Standard or other BSI publication please inform the Knowledge Centre.

## Copyright

All the data, software and documentation set out in all British Standards and other BSI publications are the property of and copyrighted by BSI, or some person or entity that owns copyright in the information used (such as the international standardization bodies) and has formally licensed such information to BSI for commercial publication and use. Except as permitted under the Copyright, Designs and Patents Act 1988 no extract may be reproduced, stored in a retrieval system or transmitted in any form or by any means – electronic, photocopying, recording or otherwise – without prior written permission from BSI. Details and advice can be obtained from the Copyright & Licensing Department.

## Useful Contacts:

### Customer Services

**Tel:** +44 845 086 9001

**Email (orders):** [orders@bsigroup.com](mailto:orders@bsigroup.com)

**Email (enquiries):** [cservices@bsigroup.com](mailto:cservices@bsigroup.com)

### Subscriptions

**Tel:** +44 845 086 9001

**Email:** [subscriptions@bsigroup.com](mailto:subscriptions@bsigroup.com)

### Knowledge Centre

**Tel:** +44 20 8996 7004

**Email:** [knowledgecentre@bsigroup.com](mailto:knowledgecentre@bsigroup.com)

### Copyright & Licensing

**Tel:** +44 20 8996 7070

**Email:** [copyright@bsigroup.com](mailto:copyright@bsigroup.com)

## BSI Group Headquarters

389 Chiswick High Road London W4 4AL UK

