

BS IEC 62530:2011



BSI Standards Publication

SystemVerilog — Unified Hardware Design, Specification and Verification Language

bsi.

...making excellence a habit.™

National foreword

This British Standard is the UK implementation of IEC 62530:2011. It supersedes BS IEC 62530:2007 which is withdrawn.

The UK participation in its preparation was entrusted to Technical Committee GEL/93, Design automation.

A list of organizations represented on this committee can be obtained on request to its secretary.

This publication does not purport to include all the necessary provisions of a contract. Users are responsible for its correct application.

© BSI 2011

ISBN 978 0 580 75663 4

ICS 25.040.01; 35.060

Compliance with a British Standard cannot confer immunity from legal obligations.

This British Standard was published under the authority of the Standards Policy and Strategy Committee on 31 July 2011.

Amendments issued since publication

Amd. No.	Date	Text affected
-----------------	-------------	----------------------



IEC 62530

Edition 2.0 2011-05

INTERNATIONAL STANDARD

IEEE Std 1800™



**SystemVerilog –
Unified Hardware Design, Specification, and Verification Language**

INTERNATIONAL
ELECTROTECHNICAL
COMMISSION

PRICE CODE **XX**

Contents

Part One:

Design and Verification Constructs

1. Overview.....	2
1.1 Scope.....	2
1.2 Purpose.....	2
1.3 Merger of IEEE Std 1364-2005 and IEEE Std 1800-2005.....	3
1.4 Special terms.....	3
1.5 Conventions used in this standard.....	3
1.6 Syntactic description.....	4
1.7 Use of color in this standard.....	5
1.8 Contents of this standard.....	5
1.9 Deprecated clauses.....	8
1.10 Examples.....	8
1.11 Prerequisites.....	8
2. Normative references.....	9
3. Design and verification building blocks.....	11
3.1 General.....	11
3.2 Design elements.....	11
3.3 Modules.....	11
3.4 Programs.....	12
3.5 Interfaces.....	13
3.6 Checkers.....	14
3.7 Primitives.....	14
3.8 Subroutines.....	14
3.9 Packages.....	14
3.10 Configurations.....	15
3.11 Overview of hierarchy.....	15
3.12 Compilation and elaboration.....	16
3.13 Name spaces.....	18
3.14 Simulation time units and precision.....	19
4. Scheduling semantics.....	23
4.1 General.....	23
4.2 Execution of a hardware model and its verification environment.....	23
4.3 Event simulation.....	23
4.4 The stratified event scheduler.....	24
4.5 The SystemVerilog simulation reference algorithm.....	29
4.6 Determinism.....	29
4.7 Nondeterminism.....	30
4.8 Race conditions.....	30
4.9 Scheduling implication of assignments.....	30
4.10 The PLI callback control points.....	32
5. Lexical conventions.....	33
5.1 General.....	33
5.2 Lexical tokens.....	33
5.3 White space.....	33
5.4 Comments.....	33
5.5 Operators.....	33
5.6 Identifiers, keywords, and system names.....	34
5.7 Numbers.....	35
5.8 Time literals.....	40

5.9	String literals	40
5.10	Structure literals	42
5.11	Array literals	43
5.12	Attributes	43
5.13	Built-in methods	45
6.	Data types	47
6.1	General	47
6.2	Data types and data objects	47
6.3	Value set	47
6.4	Singular and aggregate types	48
6.5	Nets and variables	49
6.6	Net types	50
6.7	Net declarations	56
6.8	Variable declarations	58
6.9	Vector declarations	60
6.10	Implicit declarations	61
6.11	Integer data types	62
6.12	Real, shortreal and realtime data types	63
6.13	Void data type	63
6.14	Chandle data type	63
6.15	Class	64
6.16	String data type	64
6.17	Event data type	69
6.18	User-defined types	70
6.19	Enumerations	71
6.20	Constants	77
6.21	Scope and lifetime	84
6.22	Type compatibility	86
6.23	Type operator	89
6.24	Casting	90
7.	Aggregate data types	97
7.1	General	97
7.2	Structures	97
7.3	Unions	99
7.4	Packed and unpacked arrays	102
7.5	Dynamic arrays	106
7.6	Array assignments	109
7.7	Arrays as arguments to subroutines	110
7.8	Associative arrays	111
7.9	Associative array methods	114
7.10	Queues	117
7.11	Array querying functions	121
7.12	Array manipulation methods	121
8.	Classes	127
8.1	General	127
8.2	Overview	127
8.3	Syntax	128
8.4	Objects (class instance)	129
8.5	Object properties and object parameter data	130
8.6	Object methods	130
8.7	Constructors	131
8.8	Static class properties	132
8.9	Static methods	133

8.10	This	133
8.11	Assignment, renaming, and copying	134
8.12	Inheritance and subclasses	135
8.13	Overridden members	136
8.14	Super	137
8.15	Casting	137
8.16	Chaining constructors	138
8.17	Data hiding and encapsulation	138
8.18	Constant class properties	139
8.19	Virtual methods	140
8.20	Abstract classes and pure virtual methods	141
8.21	Polymorphism: dynamic method lookup	141
8.22	Class scope resolution operator ::	142
8.23	Out-of-block declarations	144
8.24	Parameterized classes	145
8.25	Typedef class	148
8.26	Classes and structures	149
8.27	Memory management	149
9.	Processes	151
9.1	General	151
9.2	Structured procedures	151
9.3	Block statements	155
9.4	Procedural timing controls	161
9.5	Process execution threads	170
9.6	Process control	171
9.7	Fine-grain process control	175
10.	Assignment statements	177
10.1	General	177
10.2	Overview	177
10.3	Continuous assignments	178
10.4	Procedural assignments	181
10.5	Variable declaration assignment (variable initialization)	186
10.6	Procedural continuous assignments	186
10.7	Assignment extension and truncation	188
10.8	Assignment-like contexts	189
10.9	Assignment patterns	190
10.10	Unpacked array concatenation	194
10.11	Net aliasing	197
11.	Operators and expressions	199
11.1	General	199
11.2	Overview	199
11.3	Operators	200
11.4	Operator descriptions	204
11.5	Operands	224
11.6	Expression bit lengths	227
11.7	Signed expressions	230
11.8	Expression evaluation rules	231
11.9	Tagged union expressions and member access	232
11.10	String literal expressions	234
11.11	Operator overloading	235
11.12	Minimum, typical, and maximum delay expressions	237
11.13	Let construct	238
12.	Procedural programming statements	245

12.1	General	245
12.2	Overview	245
12.3	Syntax	245
12.4	Conditional if–else statement	246
12.5	Case statement	251
12.6	Pattern matching conditional statements	256
12.7	Loop statements	260
12.8	Jump statements	264
13.	Tasks and functions (subroutines)	267
13.1	General	267
13.2	Overview	267
13.3	Tasks	267
13.4	Functions	271
13.5	Subroutine calls and argument passing	277
13.6	Import and export functions	282
13.7	Task and function names	282
14.	Clocking blocks	283
14.1	General	283
14.2	Overview	283
14.3	Clocking block declaration	283
14.4	Input and output skews	285
14.5	Hierarchical expressions	286
14.6	Signals in multiple clocking blocks	287
14.7	Clocking block scope and lifetime	287
14.8	Multiple clocking blocks example	287
14.9	Interfaces and clocking blocks	288
14.10	Clocking block events	289
14.11	Cycle delay: ##	289
14.12	Default clocking	290
14.13	Input sampling	291
14.14	Global clocking	292
14.15	Synchronous events	293
14.16	Synchronous drives	293
15.	Interprocess synchronization and communication	299
15.1	General	299
15.2	Overview	299
15.3	Semaphores	299
15.4	Mailboxes	301
15.5	Named events	304
16.	Assertions	309
16.1	General	309
16.2	Overview	309
16.3	Immediate assertions	309
16.4	Deferred assertions	312
16.5	Concurrent assertions overview	316
16.6	Boolean expressions	318
16.7	Sequences	320
16.8	Declaring sequences	323
16.9	Sequence operations	331
16.10	Local variables	353
16.11	Calling subroutines on match of a sequence	359
16.12	System functions	360
16.13	Declaring properties	360

16.14 Multiclock support	385
16.15 Concurrent assertions	393
16.16 Disable iff resolution	410
16.17 Clock resolution	412
16.18 Expect statement	417
16.19 Clocking blocks and concurrent assertions	419
17. Checkers	421
17.1 Overview	421
17.2 Checker declaration	421
17.3 Checker instantiation	424
17.4 Context inference	427
17.5 Checker procedures	427
17.6 Covergroups in checkers	428
17.7 Checker variables	429
17.8 Functions in checkers	435
17.9 Complex checker example	435
18. Constrained random value generation	437
18.1 General	437
18.2 Overview	437
18.3 Concepts and usage	437
18.4 Random variables	440
18.5 Constraint blocks	442
18.6 Randomization methods	457
18.7 In-line constraints—randomize() with	459
18.8 Disabling random variables with rand_mode()	461
18.9 Controlling constraints with constraint_mode()	463
18.10 Dynamic constraint modification	464
18.11 In-line random variable control	464
18.12 Randomization of scope variables—std::randomize()	465
18.13 Random number system functions and methods	467
18.14 Random stability	468
18.15 Manually seeding randomize	471
18.16 Random weighted case—randcase	471
18.17 Random sequence generation—randsequence	472
19. Functional coverage	483
19.1 General	483
19.2 Overview	483
19.3 Defining the coverage model: covergroup	484
19.4 Using covergroup in classes	486
19.5 Defining coverage points	488
19.6 Defining cross coverage	498
19.7 Specifying coverage options	503
19.8 Predefined coverage methods	507
19.9 Predefined coverage system tasks and system functions	509
19.10 Organization of option and type_option members	509
19.11 Coverage computation	510
20. Utility system tasks and system functions	515
20.1 General	515
20.2 Simulation control system tasks	516
20.3 Simulation time system functions	516
20.4 Timescale system tasks	518
20.5 Conversion functions	521
20.6 Data query functions	522

20.7	Array querying functions	524
20.8	Math functions	526
20.9	Severity tasks	528
20.10	Elaboration system tasks	528
20.11	Assertion control system tasks	530
20.12	Assertion action control system tasks	531
20.13	Assertion system functions	533
20.14	Coverage system functions	534
20.15	Probabilistic distribution functions	534
20.16	Stochastic analysis tasks and functions	536
20.17	Programmable logic array (PLA) modeling system tasks	538
20.18	Miscellaneous tasks and functions	542
21.	I/O system tasks and system functions	543
21.1	General	543
21.2	Display system tasks	543
21.3	File input-output system tasks and system functions	554
21.4	Loading memory array data from a file	565
21.5	Writing memory array data to a file	568
21.6	Command line input	569
21.7	Value change dump (VCD) files	572
22.	Compiler directives	593
22.1	General	593
22.2	Overview	593
22.3	`resetall	593
22.4	`include	594
22.5	`define, `undef and `undefineall	594
22.6	`ifdef, `else, `elsif, `endif, `ifndef	600
22.7	`timescale	603
22.8	`default_nettype	604
22.9	`unconnected_drive and `nounconnected_drive	605
22.10	`celldefine and `endcelldefine	605
22.11	`pragma	605
22.12	`line	606
22.13	`__FILE__ and `__LINE__	607
22.14	`begin_keywords, `end_keywords	608

Part Two:

Hierarchy Constructs

23.	Modules and hierarchy	614
23.1	General	614
23.2	Module definitions	614
23.3	Module instances (hierarchy)	626
23.4	Nested modules	636
23.5	Extern modules	637
23.6	Hierarchical names	638
23.7	Member selects and hierarchical names	641
23.8	Upwards name referencing	642
23.9	Scope rules	644
23.10	Overriding module parameters	646
23.11	Binding auxiliary code to scopes or instances	654
24.	Programs	659
24.1	General	659
24.2	Overview	659

24.3	The program construct	659
24.4	Eliminating testbench races	663
24.5	Blocking tasks in cycle/event mode.....	663
24.6	Programwide space and anonymous programs.....	664
24.7	Program control tasks	664
25.	Interfaces.....	665
25.1	General.....	665
25.2	Overview.....	665
25.3	Interface syntax.....	666
25.4	Ports in interfaces.....	670
25.5	Modports.....	671
25.6	Interfaces and specify blocks.....	677
25.7	Tasks and functions in interfaces.....	678
25.8	Parameterized interfaces.....	684
25.9	Virtual interfaces.....	686
25.10	Access to interface objects.....	691
26.	Packages.....	693
26.1	General.....	693
26.2	Package declarations.....	693
26.3	Referencing data in packages.....	694
26.4	Using packages in module headers.....	698
26.5	Search order rules.....	699
26.6	Exporting imported names from packages.....	701
26.7	The std built-in package.....	702
27.	Generate constructs.....	705
27.1	General.....	705
27.2	Overview.....	705
27.3	Generate construct syntax.....	705
27.4	Loop generate constructs.....	707
27.5	Conditional generate constructs.....	711
27.6	External names for unnamed generate blocks.....	714
28.	Gate-level and switch-level modeling.....	717
28.1	General.....	717
28.2	Overview.....	717
28.3	Gate and switch declaration syntax.....	717
28.4	and, nand, nor, or, xor, and xnor gates.....	723
28.5	buf and not gates.....	724
28.6	bufif1, bufif0, notif1, and notif0 gates.....	725
28.7	MOS switches.....	726
28.8	Bidirectional pass switches.....	727
28.9	CMOS switches.....	728
28.10	pullup and pulldown sources.....	729
28.11	Logic strength modeling.....	729
28.12	Strengths and values of combined signals.....	731
28.13	Strength reduction by nonresistive devices.....	744
28.14	Strength reduction by resistive devices.....	744
28.15	Strengths of net types.....	744
28.16	Gate and net delays.....	745
29.	User defined primitives (UDPs).....	749
29.1	General.....	749
29.2	Overview.....	749
29.3	UDP definition.....	749
29.4	Combinational UDPs.....	753

29.5	Level-sensitive sequential UDPs	754
29.6	Edge-sensitive sequential UDPs	754
29.7	Sequential UDP initialization	755
29.8	UDP instances.....	757
29.9	Mixing level-sensitive and edge-sensitive descriptions.....	758
29.10	Level-sensitive dominance.....	759
30.	Specify blocks.....	761
30.1	General.....	761
30.2	Overview.....	761
30.3	Specify block declaration.....	761
30.4	Module path declarations.....	762
30.5	Assigning delays to module paths.....	771
30.6	Mixing module path delays and distributed delays.....	775
30.7	Detailed control of pulse filtering behavior.....	776
31.	Timing checks.....	785
31.1	General.....	785
31.2	Overview.....	785
31.3	Timing checks using a stability window.....	788
31.4	Timing checks for clock and control signals.....	795
31.5	Edge-control specifiers.....	804
31.6	Notifiers: user-defined responses to timing violations.....	805
31.7	Enabling timing checks with conditioned events.....	807
31.8	Vector signals in timing checks.....	808
31.9	Negative timing checks.....	809
32.	Backannotation using the standard delay format (SDF).....	815
32.1	General.....	815
32.2	Overview.....	815
32.3	The SDF annotator.....	815
32.4	Mapping of SDF constructs to SystemVerilog.....	815
32.5	Multiple annotations.....	820
32.6	Multiple SDF files.....	821
32.7	Pulse limit annotation.....	821
32.8	SDF to SystemVerilog delay value mapping.....	822
32.9	Loading timing data from an SDF file.....	822
33.	Configuring the contents of a design.....	825
33.1	General.....	825
33.2	Overview.....	825
33.3	Libraries.....	826
33.4	Configurations.....	828
33.5	Using libraries and configs.....	834
33.6	Configuration examples.....	835
33.7	Displaying library binding information.....	837
33.8	Library mapping examples.....	837
34.	Protected envelopes.....	841
34.1	General.....	841
34.2	Overview.....	841
34.3	Processing protected envelopes.....	841
34.4	Protect pragma directives.....	843
34.5	Protect pragma keywords.....	845

Part Three:**Application Programming Interfaces**

35. Direct programming interface (DPI).....	862
35.1 General.....	862
35.2 Overview.....	862
35.3 Two layers of the DPI.....	863
35.4 Global name space of imported and exported functions.....	864
35.5 Imported tasks and functions.....	865
35.6 Calling imported functions.....	872
35.7 Exported functions.....	874
35.8 Exported tasks.....	875
35.9 Disabling DPI tasks and functions.....	875
36. Programming language interface (PLI/VPI) overview.....	877
36.1 General.....	877
36.2 PLI purpose and history.....	877
36.3 User-defined system task and system function names.....	878
36.4 User-defined system task and system function arguments.....	879
36.5 User-defined system task and system function types.....	879
36.6 User-supplied PLI applications.....	879
36.7 PLI include files.....	879
36.8 VPI sizetf, compiletf and calltf routines.....	879
36.9 PLI mechanism.....	880
36.10 VPI access to SystemVerilog objects and simulation objects.....	882
36.11 List of VPI routines by functional category.....	883
36.12 VPI backwards compatibility features and limitations.....	885
37. VPI object model diagrams.....	891
37.1 General.....	891
37.2 VPI Handles.....	891
37.3 VPI object classifications.....	892
37.4 Key to data model diagrams.....	898
37.5 Module.....	901
37.6 Interface.....	902
37.7 Modport.....	902
37.8 Interface task or function declaration.....	902
37.9 Program.....	903
37.10 Instance.....	904
37.11 Instance arrays.....	906
37.12 Scope.....	907
37.13 IO declaration.....	908
37.14 Ports.....	909
37.15 Reference objects.....	910
37.16 Nets.....	913
37.17 Variables.....	917
37.18 Packed array variables.....	920
37.19 Variable select.....	921
37.20 Memory.....	922
37.21 Variable drivers and loads.....	922
37.22 Object Range.....	923
37.23 Typespec.....	924
37.24 Structures and unions.....	926
37.25 Named events.....	927
37.26 Parameter, spec param, def param, param assign.....	928
37.27 Class definition.....	929

37.28 Class typespec	930
37.29 Class variables and class objects.....	932
37.30 Constraint, constraint ordering, distribution	934
37.31 Primitive, prim term.....	935
37.32 UDP.....	936
37.33 Intermodule path	936
37.34 Constraint expression	937
37.35 Module path, path term	937
37.36 Timing check	938
37.37 Task and function declaration	939
37.38 Task and function call	940
37.39 Frames	942
37.40 Threads	943
37.41 Delay terminals	943
37.42 Net drivers and loads	944
37.43 Continuous assignment	945
37.44 Clocking block	946
37.45 Assertion	947
37.46 Concurrent assertions	948
37.47 Property declaration	949
37.48 Property specification	950
37.49 Sequence declaration	951
37.50 Sequence expression	952
37.51 Immediate assertions	953
37.52 Multiclock sequence expression	954
37.53 Let	954
37.54 Simple expressions	955
37.55 Expressions	956
37.56 Atomic statement	959
37.57 Event statement	960
37.58 Process	960
37.59 Assignment	961
37.60 Event control	961
37.61 While, repeat	962
37.62 Waits	962
37.63 Delay control.....	962
37.64 Repeat control	963
37.65 Forever	963
37.66 If, if-else	963
37.67 Case, pattern	964
37.68 Expect	965
37.69 For	965
37.70 Do-while, foreach	965
37.71 Alias statement	966
37.72 Disables.....	967
37.73 Return statement	967
37.74 Assign statement, deassign, force, release.....	967
37.75 Callback	968
37.76 Time queue.....	968
37.77 Active time format.....	969
37.78 Attribute	970
37.79 Iterator.....	971
37.80 Generates	972
38. VPI routine definitions.....	975

38.1	General	975
38.2	vpi_chk_error()	975
38.3	vpi_compare_objects()	976
38.4	vpi_control()	978
38.5	vpi_flush()	979
38.6	vpi_get()	979
38.7	vpi_get64()	980
38.8	vpi_get_cb_info()	980
38.9	vpi_get_data()	981
38.10	vpi_get_delays()	982
38.11	vpi_get_str()	984
38.12	vpi_get_systf_info()	985
38.13	vpi_get_time()	986
38.14	vpi_get_userdata()	987
38.15	vpi_get_value()	987
38.16	vpi_get_value_array()	993
38.17	vpi_get_vlog_info()	997
38.18	vpi_handle()	998
38.19	vpi_handle_by_index()	999
38.20	vpi_handle_by_multi_index()	999
38.21	vpi_handle_by_name()	1000
38.22	vpi_handle_multi()	1001
38.23	vpi_iterate()	1001
38.24	vpi_mcd_close()	1002
38.25	vpi_mcd_flush()	1003
38.26	vpi_mcd_name()	1003
38.27	vpi_mcd_open()	1004
38.28	vpi_mcd_printf()	1005
38.29	vpi_mcd_vprintf()	1006
38.30	vpi_printf()	1006
38.31	vpi_put_data()	1007
38.32	vpi_put_delays()	1009
38.33	vpi_put_userdata()	1012
38.34	vpi_put_value()	1012
38.35	vpi_put_value_array()	1015
38.36	vpi_register_cb()	1019
38.37	vpi_register_systf()	1027
38.38	vpi_release_handle()	1030
38.39	vpi_remove_cb()	1031
38.40	vpi_scan()	1031
38.41	vpi_vprintf()	1032
39.	Assertion API	1033
39.1	General	1033
39.2	Overview	1033
39.3	Static information	1033
39.4	Dynamic information	1034
39.5	Control functions	1038
40.	Code coverage control and API	1043
40.1	General	1043
40.2	Overview	1043
40.3	SystemVerilog real-time coverage access	1044
40.4	FSM recognition	1049
40.5	VPI coverage extensions	1051
41.	Data read API	1057

Part Four:

Annexes

Annex A (normative) Formal syntax	1060
A.1 Source text	1060
A.2 Declarations	1068
A.3 Primitive instances	1079
A.4 Instantiations	1081
A.5 UDP declaration and instantiation	1082
A.6 Behavioral statements	1084
A.7 Specify section	1090
A.8 Expressions	1094
A.9 General	1100
A.10 Footnotes (normative)	1102
Annex B (normative) Keywords	1105
Annex C (normative) Deprecation	1107
C.1 General	1107
C.2 Constructs that have been deprecated	1107
C.3 Accellera SystemVerilog 3.1a-compatible access to packed data	1108
C.4 Constructs identified for deprecation	1108
Annex D (informative) Optional system tasks and system functions	1111
D.1 General	1111
D.2 \$countdrivers	1111
D.3 \$getpattern	1112
D.4 \$input	1113
D.5 \$key and \$nokey	1113
D.6 \$list	1113
D.7 \$log and \$nolog	1114
D.8 \$reset, \$reset_count, and \$reset_value	1114
D.9 \$save, \$restart, and \$incsave	1115
D.10 \$scale	1116
D.11 \$scope	1116
D.12 \$showscopes	1116
D.13 \$showvars	1116
D.14 \$readmemb and \$readmemh	1117
Annex E (informative) Optional compiler directives	1119
E.1 General	1119
E.2 `default_decay_time	1119
E.3 `default_trireg_strength	1119
E.4 `delay_mode_distributed	1120
E.5 `delay_mode_path	1120
E.6 `delay_mode_unit	1120
E.7 `delay_mode_zero	1120
Annex F (normative) Formal semantics of concurrent assertions	1121
F.1 General	1121
F.2 Overview	1121
F.3 Abstract syntax	1122
F.4 Rewriting algorithms	1128
F.5 Semantics	1132
F.6 Extended expressions	1141
F.7 Recursive properties	1141
Annex G (normative) Std package	1145
G.1 General	1145
G.2 Overview	1145

G.3 Semaphore.....	1145
G.4 Mailbox.....	1145
G.5 Randomize.....	1146
G.6 Process.....	1146
Annex H (normative) DPI C layer.....	1147
H.1 General.....	1147
H.2 Overview.....	1147
H.3 Naming conventions.....	1148
H.4 Portability.....	1148
H.5 svdpi.h include file.....	1148
H.6 Semantic constraints.....	1149
H.7 Data types.....	1152
H.8 Argument passing modes.....	1155
H.9 Context tasks and functions.....	1158
H.10 Include files.....	1163
H.11 Arrays.....	1166
H.12 Open arrays.....	1168
H.13 SV3.1a-compatible access to packed data (deprecated functionality).....	1174
Annex I (normative) svdpi.h.....	1181
I.1 General.....	1181
I.2 Overview.....	1181
I.3 Source code.....	1181
Annex J (normative) Inclusion of foreign language code.....	1191
J.1 General.....	1191
J.2 Overview.....	1191
J.3 Location independence.....	1192
J.4 Object code inclusion.....	1192
Annex K (normative) vpi_user.h.....	1195
K.1 General.....	1195
K.2 Source code.....	1195
Annex L (normative) vpi_compatibility.h.....	1213
L.1 General.....	1213
L.2 Source code.....	1213
Annex M (normative) sv_vpi_user.h.....	1217
M.1 General.....	1217
M.2 Source code.....	1217
Annex N (normative) Algorithm for probabilistic distribution functions.....	1227
N.1 General.....	1227
N.2 Source code.....	1227
Annex O (informative) Encryption/decryption flow.....	1235
O.1 General.....	1235
O.2 Overview.....	1235
O.3 Tool vendor secret key encryption system.....	1235
O.4 IP author secret key encryption system.....	1236
O.5 Digital envelopes.....	1237
Annex P (informative) Glossary.....	1239
Annex Q (informative) Mapping of IEEE Std 1364-2005 and IEEE Std 1800-2005 clauses into IEEE Std 1800-2009.....	1243
Annex R (informative) Bibliography.....	1247
Annex S (informative) IEEE List of Participants.....	1249

List of figures

Figure 4-1—Event scheduling regions	28
Figure 6-1—Simulation values of a trireg and its driver	53
Figure 6-2—Simulation results of a capacitive network	54
Figure 6-3—Simulation results of charge sharing	55
Figure 7-1—VInt type with packed qualifier.....	102
Figure 7-2—Instr type with packed qualifier.....	102
Figure 9-1—Intra-assignment repeat event control utilizing a clock edge.....	170
Figure 14-1—Sample and drive times including skew with respect to the positive edge of the clock	286
Figure 16-1—Sampling a variable in a simulation time step	317
Figure 16-2—Concatenation of sequences	322
Figure 16-3—Value change expressions	337
Figure 16-4—Future value change	341
Figure 16-5—ANDing (and) two sequences	343
Figure 16-6—ANDing (and) two sequences, including a time range	344
Figure 16-7—ANDing (and) two Boolean expressions.....	344
Figure 16-8—Intersecting two sequences.....	345
Figure 16-9—ORing (or) two Boolean expressions	346
Figure 16-10—ORing (or) two sequences.....	347
Figure 16-11—ORing (or) two sequences, including a time range	348
Figure 16-12—Match with throughout restriction fails.....	350
Figure 16-13—Match with throughout restriction succeeds	351
Figure 16-14—Conditional sequence matching	367
Figure 16-15—Conditional sequences.....	368
Figure 16-16—Results without the condition.....	368
Figure 16-17—Clocking blocks and concurrent assertion.....	419
Figure 17-1—Non-deterministic free checker variable	430
Figure 18-1—Example of randc	442
Figure 18-2—Global constraints.....	451
Figure 18-3—Truth tables for conjunction, disjunction, and negation rules.....	455
Figure 21-1—Creating the 4-state VCD file.....	572
Figure 21-2—Creating the extended VCD file.....	582
Figure 23-1—Scopes available to upward name referencing.....	646
Figure 28-1—Schematic diagram of interconnections in array of instances.....	723
Figure 28-2—Scale of strengths	731
Figure 28-3—Combining unequal strengths.....	731
Figure 28-4—Combination of signals of equal strength and opposite values	732
Figure 28-5—Weak x signal strength.....	732
Figure 28-6—Bufifs with control inputs of x	733
Figure 28-7—Strong H range of values.....	733

Figure 28-8—Strong L range of values	733
Figure 28-9—Combined signals of ambiguous strength	734
Figure 28-10—Range of strengths for an unknown signal	734
Figure 28-11—Ambiguous strengths from switch networks	735
Figure 28-12—Range of two strengths of a defined value	735
Figure 28-13—Range of three strengths of a defined value	735
Figure 28-14—Unknown value with a range of strengths	736
Figure 28-15—Strong X range	736
Figure 28-16—Ambiguous strength from gates	736
Figure 28-17—Ambiguous strength signal from a gate	737
Figure 28-18—Weak 0	737
Figure 28-19—Ambiguous strength in combined gate signals	737
Figure 28-20—Elimination of strength levels	738
Figure 28-21—Result showing a range and the elimination of strength levels of two values	739
Figure 28-22—Result showing a range and the elimination of strength levels of one value	740
Figure 28-23—A range of both values	741
Figure 28-24—Wired logic with unambiguous strength signals	741
Figure 28-25—Wired logic and ambiguous strengths	743
Figure 28-26—Trireg net with capacitance	748
Figure 29-1—Module schematic and simulation times of initial value propagation	757
Figure 30-1—Module path delays	763
Figure 30-2—Difference between parallel and full connection paths	769
Figure 30-3—Module path delays longer than distributed delays	776
Figure 30-4—Module path delays shorter than distributed delays	776
Figure 30-5—Example of pulse filtering	777
Figure 30-6—On-detect versus on-event	779
Figure 30-7—Current event cancellation problem and correction	781
Figure 30-8—NAND gate with nearly simultaneous input switching where one event is scheduled prior to another that has not matured	782
Figure 30-9—NAND gate with nearly simultaneous input switching with output event scheduled at same time	783
Figure 31-1—Sample \$timeskew	797
Figure 31-2—Sample \$timeskew with remain_active_flag set	798
Figure 31-3—Sample \$fullskew	800
Figure 31-4—Data constraint interval, positive setup/hold	809
Figure 31-5—Data constraint interval, negative setup/hold	810
Figure 31-6—Timing check violation windows	813
Figure 37-1—Example of object relationships diagram	893
Figure 37-2—Accessing a class of objects using tags	894
Figure 38-1—s_vpi_error_info structure definition	976
Figure 38-2—s_cb_data structure definition	981

Figure 38-3—s_vpi_delay structure definition	982
Figure 38-4—s_vpi_time structure definition	982
Figure 38-5—s_vpi_systf_data structure definition	985
Figure 38-6—s_vpi_time structure definition	986
Figure 38-7—s_vpi_value structure definition	988
Figure 38-8—s_vpi_vecval structure definition	988
Figure 38-9—s_vpi_strengthval structure definition	988
Figure 38-10—s_vpi_vlog_info structure definition	997
Figure 38-11—s_vpi_delay structure definition	1010
Figure 38-12—s_vpi_time structure definition	1010
Figure 38-13—s_vpi_value structure definition	1014
Figure 38-14—s_vpi_time structure definition	1014
Figure 38-15—s_vpi_vecval structure definition	1015
Figure 38-16—s_vpi_strengthval structure definition	1015
Figure 38-17—s_cb_data structure definition	1019
Figure 38-18—s_vpi_systf_data structure definition	1027
Figure 39-1—Assertions with global clocking future sampled value functions.....	1038
Figure 40-1—Hierarchical instance example	1046
Figure 40-2—FSM specified with pragmas.....	1051

List of tables

Table 3-1—Time unit strings.....	19
Table 4-1—PLI callbacks.....	32
Table 5-1—Specifying special characters in string literals.....	41
Table 6-1—Net types.....	50
Table 6-2—Truth table for wire and tri nets.....	51
Table 6-3—Truth table for wand and triand nets.....	52
Table 6-4—Truth table for wor and trior nets.....	52
Table 6-5—Truth table for tri0 net.....	56
Table 6-6—Truth table for tri1 net.....	56
Table 6-7—Default values.....	60
Table 6-8—Integer data types.....	62
Table 6-9—String operators.....	66
Table 6-10—Enumeration element ranges.....	73
Table 6-11—Differences between specparams and parameters.....	83
Table 7-1—Value read from a nonexistent associative array entry.....	114
Table 8-1—Comparison of pointer and handle types.....	129
Table 9-1—fork-join control options.....	157
Table 9-2—Detecting posedge and negedge.....	163
Table 9-3—Intra-assignment timing control equivalence.....	169
Table 10-1—Legal left-hand forms in assignment statements.....	177
Table 11-1—Operators and data types.....	201
Table 11-2—Operator precedence and associativity.....	202
Table 11-3—Arithmetic operators defined.....	205
Table 11-4—Power operator rules.....	206
Table 11-5—Unary operators defined.....	206
Table 11-6—Examples of modulus and power operators.....	206
Table 11-7—Data type interpretation by arithmetic operators.....	207
Table 11-8—Definitions of relational operators.....	208
Table 11-9—Definitions of equality operators.....	209
Table 11-10—Wildcard equality and wildcard inequality operators.....	209
Table 11-11—Bitwise binary and operator.....	211
Table 11-12—Bitwise binary or operator.....	211
Table 11-13—Bitwise binary exclusive or operator.....	212
Table 11-14—Bitwise binary exclusive nor operator.....	212
Table 11-15—Bitwise unary negation operator.....	212
Table 11-16—Reduction unary and operator.....	213
Table 11-17—Reduction unary or operator.....	213
Table 11-18—Reduction unary exclusive or operator.....	213
Table 11-19—Results of unary reduction operations.....	214

Table 11-20—Ambiguous condition results for conditional operator	215
Table 11-21—Bit lengths resulting from self-determined expressions	228
Table 16-1—Operator precedence and associativity	331
Table 16-2—Global clocking future sampled value functions	341
Table 16-3—Sequence and property operator precedence and associativity	363
Table 18-1—rand_mode argument	462
Table 18-2—constraint_mode argument	463
Table 19-1—Instance-specific coverage options	503
Table 19-2—Coverage options per-syntactic level	505
Table 19-3—Coverage group type (static) options	505
Table 19-4—Coverage type options	507
Table 19-5—Predefined coverage methods	507
Table 20-1—Diagnostics for \$finish	516
Table 20-2—\$timeformat units_number arguments	519
Table 20-3—\$timeformat default value for arguments	520
Table 20-4—SystemVerilog to C real math function cross-listing	527
Table 20-5—VPI callbacks for assertion control tasks	531
Table 20-6—VPI callbacks for assertion action control tasks	532
Table 20-7—Types of queues of \$q_type values	536
Table 20-8—Argument values for \$q_exam system task	537
Table 20-9—Status code values	537
Table 20-10—PLA modeling system tasks	538
Table 21-1—Escape sequences for printing special characters	544
Table 21-2—Escape sequences for format specifications	545
Table 21-3—Format specifications for real numbers	547
Table 21-4—Logic value component of strength format	550
Table 21-5—Mnemonics for strength levels	550
Table 21-6—Explanation of strength formats	551
Table 21-7—Types for file descriptors	555
Table 21-8—\$fscanf input field characters	559
Table 21-9—Rules for left-extending vector values	578
Table 21-10—How the VCD can shorten values	578
Table 21-11—Keyword commands	579
Table 21-12—VCD type mapping	591
Table 22-1—IEEE Std 1364-1995 reserved keywords	610
Table 22-2—IEEE Std 1364-2001 additional reserved keywords	611
Table 22-3—IEEE Std 1364-2005 additional reserved keywords	611
Table 22-4—IEEE Std 1800-2005 additional reserved keywords	612
Table 22-5—IEEE Std 1800-2009 additional reserved keywords	612
Table 23-1—Net types resulting from dissimilar port connections	635

Table 26-1—Scoping rules for package importation.....	700
Table 28-1—Built-in gates and switches.....	718
Table 28-2—Valid gate types for strength specifications.....	719
Table 28-3—Truth tables for multiple input logic gates	724
Table 28-4—Truth tables for multiple output logic gates	725
Table 28-5—Truth tables for three-state logic gates	726
Table 28-6—Truth tables for MOS switches	727
Table 28-7—Strength levels for scalar net signal values.....	730
Table 28-8—Strength reduction rules.....	744
Table 28-9—Rules for propagation delays.....	745
Table 29-1—UDP table symbols.....	752
Table 29-2—Initial statements in UDPs and modules.....	755
Table 29-3—Mixing of level-sensitive and edge-sensitive entries.....	759
Table 30-1—List of valid operators in state-dependent path delay expression.....	766
Table 30-2—Associating path delay expressions with transitions	773
Table 30-3—Calculating delays for x transitions	774
Table 31-1—\$setup arguments	788
Table 31-2—\$hold arguments	789
Table 31-3—\$setuphold arguments	790
Table 31-4—\$removal arguments	792
Table 31-5—\$recovery arguments	793
Table 31-6—\$recrem arguments	794
Table 31-7—\$skew arguments	796
Table 31-8—\$timeskew arguments.....	797
Table 31-9—\$fullskew arguments.....	799
Table 31-10—\$width arguments	801
Table 31-11—\$period arguments	802
Table 31-12—\$nochange arguments	803
Table 31-13—Notifier value responses to timing violations	805
Table 32-1—Mapping of SDF delay constructs to SystemVerilog declarations.....	816
Table 32-2—Mapping of SDF timing check constructs to SystemVerilog.....	817
Table 32-3—SDF annotation of interconnect delays.....	819
Table 32-4—SDF to SystemVerilog delay value mapping	822
Table 32-5—mtm_spec argument.....	823
Table 32-6—scale_type argument	824
Table 34-1—protect pragma keywords	844
Table 34-2—Encoding algorithm identifiers	848
Table 34-3—Encryption algorithm identifiers.....	850
Table 34-4—Message digest algorithm identifiers.....	855
Table 36-1—VPI routines for simulation-related callbacks	883

Table 36-2—VPI routines for system task or system function callbacks	884
Table 36-3—VPI routines for traversing SystemVerilog hierarchy	884
Table 36-4—VPI routines for accessing properties of objects	884
Table 36-5—VPI routines for accessing objects from properties.....	884
Table 36-6—VPI routines for delay processing	884
Table 36-7—VPI routines for logic and strength value processing.....	884
Table 36-8—VPI routines for simulation time processing	885
Table 36-9—VPI routines for miscellaneous utilities	885
Table 36-10—Summary of VPI incompatibilities across standard versions.....	886
Table 37-1—Part-select parent expressions.....	958
Table 38-1—Return error constants for vpi_chk_error().....	976
Table 38-2—Size of the s_vpi_delay->da array	983
Table 38-3—Return value field of the s_vpi_value structure union.....	989
Table 38-4—Size of the s_vpi_delay->da array	1010
Table 38-5—Value format field of cb_data_p->value->format	1021
Table 38-6—cbStmt callbacks	1023
Table 40-1—Coverage control return values.....	1045
Table 40-2—Instance coverage permutations	1046
Table 40-3—Assertion coverage results.....	1053
Table B.1—Reserved keywords	1105
Table D.1—Argument return value for \$countdriver function.....	1112
Table H.1—Mapping data types	1153
Table N.1—SystemVerilog to C function cross-listing.....	1227
Table Q.1—Mapping of LRM clauses.....	1243

List of syntax excerpts

Syntax 5-1—Syntax for system tasks and system functions (excerpt from Annex A).....	35
Syntax 5-2—Syntax for integer and real numbers (excerpt from Annex A).....	36
Syntax 5-3—Syntax for attributes (excerpt from Annex A).....	44
Syntax 6-1—Syntax for net declarations (excerpt from Annex A).....	57
Syntax 6-2—Syntax for variable declarations (excerpt from Annex A).....	59
Syntax 6-3—User-defined types (excerpt from Annex A).....	70
Syntax 6-4—Enumerated types (excerpt from Annex A).....	72
Syntax 6-5—Parameter declaration syntax (excerpt from Annex A).....	78
Syntax 6-6—Casting (excerpt from Annex A).....	90
Syntax 7-1—Structure declaration syntax (excerpt from Annex A).....	97
Syntax 7-2—Union declaration syntax (excerpt from Annex A).....	99
Syntax 7-3—Dynamic array new constructor syntax (excerpt from Annex A).....	107
Syntax 7-4—Declaration of queue dimension (excerpt from Annex A).....	118
Syntax 7-5—Array method call syntax (not in Annex A).....	121
Syntax 8-1—Class syntax (excerpt from Annex A).....	129
Syntax 9-1—Syntax for structured procedures (excerpt from Annex A).....	151
Syntax 9-2—Syntax for sequential block (excerpt from Annex A).....	155
Syntax 9-3—Syntax for parallel block (excerpt from Annex A).....	156
Syntax 9-4—Delay and event control syntax (excerpt from Annex A).....	162
Syntax 9-5—Syntax for wait statement (excerpt from Annex A).....	167
Syntax 9-6—Syntax for intra-assignment delay and event control (excerpt from Annex A).....	168
Syntax 9-7—Syntax for process control statements (excerpt from Annex A).....	171
Syntax 10-1—Syntax for continuous assignment (excerpt from Annex A).....	178
Syntax 10-2—Blocking assignment syntax (excerpt from Annex A).....	182
Syntax 10-3—Nonblocking assignment syntax (excerpt from Annex A).....	183
Syntax 10-4—Syntax for procedural continuous assignments (excerpt from Annex A).....	186
Syntax 10-5—Assignment patterns syntax (excerpt from Annex A).....	191
Syntax 10-6—Syntax for net aliasing (excerpt from Annex A).....	197
Syntax 11-1—Operator syntax (excerpt from Annex A).....	200
Syntax 11-2—Conditional operator syntax (excerpt from Annex A).....	215
Syntax 11-3—Inside expression syntax (excerpt from Annex A).....	218
Syntax 11-4—Streaming concatenation syntax (excerpt from Annex A).....	220
Syntax 11-5—With expression syntax (excerpt from Annex A).....	222
Syntax 11-6—Tagged union syntax (excerpt from Annex A).....	232
Syntax 11-7—Operator overloading syntax (excerpt from Annex A).....	235
Syntax 11-8—Syntax for min:typ:max expression (excerpt from Annex A).....	238
Syntax 11-9—Let syntax (excerpt from Annex A).....	239
Syntax 12-1—Procedural statement syntax (excerpt from Annex A).....	246
Syntax 12-2—Syntax for if-else statement (excerpt from Annex A).....	246

Syntax 12-3—Syntax for case statements (excerpt from Annex A).....	251
Syntax 12-4—Pattern syntax (excerpt from Annex A).....	256
Syntax 12-5—Loop statement syntax (excerpt from Annex A).....	260
Syntax 12-6—Jump statement syntax (excerpt from Annex A).....	264
Syntax 13-1—Task syntax (excerpt from Annex A).....	268
Syntax 13-2—Function syntax (excerpt from Annex A).....	272
Syntax 13-3—Task or function call syntax (excerpt from Annex A).....	278
Syntax 14-1—Clocking block syntax (excerpt from Annex A).....	284
Syntax 14-2—Cycle delay syntax (excerpt from Annex A).....	289
Syntax 14-3—Default clocking syntax (excerpt from Annex A).....	290
Syntax 14-4—Global clocking syntax (excerpt from Annex A).....	292
Syntax 14-5—Synchronous drive syntax (excerpt from Annex A).....	294
Syntax 15-1—Event trigger syntax (excerpt from Annex A).....	305
Syntax 15-2—Wait_order event sequencing syntax (excerpt from Annex A).....	306
Syntax 16-1—Immediate assertion syntax (excerpt from Annex A).....	310
Syntax 16-2—Deferred immediate assertion syntax (excerpt from Annex A).....	312
Syntax 16-3—Sequence syntax (excerpt from Annex A).....	320
Syntax 16-4—Sequence concatenation syntax (excerpt from Annex A).....	321
Syntax 16-5—Declaring sequence syntax (excerpt from Annex A).....	324
Syntax 16-6—Sequence repetition syntax (excerpt from Annex A).....	332
Syntax 16-7—And operator syntax (excerpt from Annex A).....	342
Syntax 16-8—Intersect operator syntax (excerpt from Annex A).....	344
Syntax 16-9—Or operator syntax (excerpt from Annex A).....	345
Syntax 16-10—First_match operator syntax (excerpt from Annex A).....	348
Syntax 16-11—Throughout construct syntax (excerpt from Annex A).....	350
Syntax 16-12—Within construct syntax (excerpt from Annex A).....	351
Syntax 16-13—Assertion variable declaration syntax (excerpt from Annex A).....	353
Syntax 16-14—Variable assignment syntax (excerpt from Annex A).....	354
Syntax 16-15—Subroutine call in sequence syntax (excerpt from Annex A).....	359
Syntax 16-16—Property construct syntax (excerpt from Annex A).....	362
Syntax 16-17—Implication syntax (excerpt from Annex A).....	366
Syntax 16-18—Followed-by syntax (excerpt from Annex A).....	370
Syntax 16-19—Property statement case syntax (excerpt from Annex A).....	378
Syntax 16-20—Concurrent assert construct syntax (excerpt from Annex A).....	394
Syntax 16-21—Default clocking and default disable syntax (excerpt from Annex A).....	410
Syntax 16-22—Expect statement syntax (excerpt from Annex A).....	418
Syntax 17-1—Checker declaration syntax (excerpt from Annex A).....	422
Syntax 17-2—Checker instantiation syntax (excerpt from Annex A).....	424
Syntax 18-1—Random variable declaration syntax (excerpt from Annex A).....	440
Syntax 18-2—Constraint syntax (excerpt from Annex A).....	443

Syntax 18-3—Constraint distribution syntax (excerpt from Annex A)	446
Syntax 18-4—Constraint implication syntax (excerpt from Annex A)	447
Syntax 18-5—If–else constraint syntax (excerpt from Annex A)	448
Syntax 18-6—Foreach iterative constraint syntax (excerpt from Annex A)	449
Syntax 18-7—Solve...before constraint ordering syntax (excerpt from Annex A)	452
Syntax 18-8—Static constraint syntax (excerpt from Annex A)	453
Syntax 18-9—In-line constraint syntax (excerpt from Annex A)	459
Syntax 18-10—Scope randomize function syntax (not in Annex A)	465
Syntax 18-11—Randcase syntax (excerpt from Annex A)	471
Syntax 18-12—Randsequence syntax (excerpt from Annex A)	473
Syntax 18-13—Random production weights syntax (excerpt from Annex A)	474
Syntax 18-14—If–else conditional random production syntax (excerpt from Annex A)	475
Syntax 18-15—Case random production syntax (excerpt from Annex A)	475
Syntax 18-16—Repeat random production syntax (excerpt from Annex A)	476
Syntax 18-17—Rand join random production syntax (excerpt from Annex A)	476
Syntax 18-18—Random production syntax (excerpt from Annex A)	478
Syntax 19-1—Covergroup syntax (excerpt from Annex A)	484
Syntax 19-2—Coverage point syntax (excerpt from Annex A)	488
Syntax 19-3—Transition bin syntax (excerpt from Annex A)	492
Syntax 19-4—Cross coverage syntax (excerpt from Annex A)	498
Syntax 20-1—Syntax for simulation control tasks (not in Annex A)	516
Syntax 20-2—Syntax for time system functions (not in Annex A)	516
Syntax 20-3—Syntax for \$printtimescale (not in Annex A)	518
Syntax 20-4—Syntax for \$timeformat (not in Annex A)	519
Syntax 20-5—Type name function syntax (not in Annex A)	522
Syntax 20-6—Size function syntax (not in Annex A)	523
Syntax 20-7—Range function syntax (not in Annex A)	524
Syntax 20-8—Array querying function syntax (not in Annex A)	524
Syntax 20-9—Severity system task syntax (not in Annex A)	528
Syntax 20-10—Elaboration system task syntax (excerpt from Annex A)	529
Syntax 20-11—Assertion control syntax (not in Annex A)	530
Syntax 20-12—Assertion action control syntax (not in Annex A)	531
Syntax 20-13—Assertion system function syntax (not in Annex A)	533
Syntax 20-14—Syntax for \$random (not in Annex A)	534
Syntax 20-15—Syntax for probabilistic distribution functions (not in Annex A)	535
Syntax 20-16—Syntax for PLA modeling system task (not in Annex A)	538
Syntax 20-17—System function syntax (not in Annex A)	542
Syntax 21-1—Syntax for \$display and \$write system tasks (not in Annex A)	544
Syntax 21-2—Syntax for \$strobe system tasks (not in Annex A)	553
Syntax 21-3—Syntax for \$monitor system tasks (not in Annex A)	553

Syntax 21-4—Syntax for \$fopen and \$fclose system tasks (not in Annex A)	554
Syntax 21-5—Syntax for file output system tasks (not in Annex A)	556
Syntax 21-6—Syntax for formatting data tasks (not in Annex A)	557
Syntax 21-7—Syntax for file read system functions (not in Annex A).....	558
Syntax 21-8—Syntax for file positioning system functions (not in Annex A).....	563
Syntax 21-9—Syntax for file flush system task (not in Annex A)	564
Syntax 21-10—Syntax for file I/O error detection system function (not in Annex A)	564
Syntax 21-11—Syntax for end-of-file file detection system function (not in Annex A)	564
Syntax 21-12—Syntax for memory load system tasks (not in Annex A).....	565
Syntax 21-13—Writemem system task syntax (not in Annex A).....	568
Syntax 21-14—Syntax for \$dumpfile task (not in Annex A)	573
Syntax 21-15—Syntax for \$dumpvars task (not in Annex A).....	573
Syntax 21-16—Syntax for \$dumpoff and \$dumpon tasks (not in Annex A)	574
Syntax 21-17—Syntax for \$dumpall task (not in Annex A)	575
Syntax 21-18—Syntax for \$dumplimit task (not in Annex A).....	575
Syntax 21-19—Syntax for \$dumpflush task (not in Annex A)	575
Syntax 21-20—Syntax for output 4-state VCD file (not in Annex A)	577
Syntax 21-21—Syntax for \$dumpports task (not in Annex A)	582
Syntax 21-22—Syntax for \$dumpportsoff and \$dumpportson system tasks (not in Annex A)	583
Syntax 21-23—Syntax for \$dumpportsall system task (not in Annex A)	584
Syntax 21-24—Syntax for \$dumpportslimit system task (not in Annex A).....	584
Syntax 21-25—Syntax for \$dumpportsflush system task (not in Annex A)	585
Syntax 21-26—Syntax for \$vcdclose keyword (not in Annex A).....	585
Syntax 21-27—Syntax for output extended VCD file (not in Annex A)	587
Syntax 21-28—Syntax for extended VCD node information (not in Annex A)	587
Syntax 21-29—Syntax for value change section (not in Annex A).....	589
Syntax 22-1—Syntax for include compiler directive (not in Annex A).....	594
Syntax 22-2—Syntax for text macro definition (not in Annex A)	595
Syntax 22-3—Syntax for text macro usage (not in Annex A).....	596
Syntax 22-4—Syntax for undef compiler directive (not in Annex A).....	600
Syntax 22-5—Syntax for conditional compilation directives (not in Annex A)	600
Syntax 22-6—Syntax for timescale compiler directive (not in Annex A).....	603
Syntax 22-7—Syntax for default_nettype compiler directive (not in Annex A).....	605
Syntax 22-8—Syntax for pragma compiler directive (not in Annex A).....	606
Syntax 22-9—Syntax for line compiler directive (not in Annex A).....	607
Syntax 22-10—Syntax for begin_keywords and end_keywords compiler directives (not in Annex A).....	608
Syntax 23-1—Module declaration syntax (excerpt from Annex A).....	615
Syntax 23-2—Non-ANSI style module header declaration syntax (excerpt from Annex A)	616
Syntax 23-3—Non-ANSI style port declaration syntax (excerpt from Annex A).....	617
Syntax 23-4—ANSI style list_of_port_declarations syntax (excerpt from Annex A).....	620

Syntax 23-5—Module item syntax (excerpt from Annex A)	626
Syntax 23-6—Module instance syntax (excerpt from Annex A)	627
Syntax 23-7—Syntax for hierarchical path names (excerpt from Annex A).....	639
Syntax 23-8—Syntax for upward name referencing (not in Annex A)	642
Syntax 23-9—Bind construct syntax (excerpt from Annex A)	655
Syntax 24-1—Program declaration syntax (excerpt from Annex A)	660
Syntax 25-1—Interface syntax (excerpt from Annex A).....	666
Syntax 25-2—Modport clocking declaration syntax (excerpt from Annex A)	676
Syntax 25-3—Virtual interface declaration syntax (excerpt from Annex A).....	686
Syntax 26-1—Package declaration syntax (excerpt from Annex A).....	694
Syntax 26-2—Package import syntax (excerpt from Annex A).....	695
Syntax 26-3—Package import in header syntax (excerpt from Annex A)	699
Syntax 26-4—Package export syntax (excerpt from Annex A)	701
Syntax 26-5—Std package import syntax (not in Annex A)	703
Syntax 27-1—Syntax for generate constructs (excerpt from Annex A).....	707
Syntax 28-1—Syntax for gate instantiation (excerpt from Annex A)	718
Syntax 29-1—Syntax for UDPs (excerpt from Annex A).....	750
Syntax 29-2—Syntax for UDP instances (excerpt from Annex A).....	757
Syntax 30-1—Syntax for specify block (excerpt from Annex A)	761
Syntax 30-2—Syntax for module path declaration (excerpt from Annex A).....	762
Syntax 30-3—Syntax for simple module path (excerpt from Annex A)	763
Syntax 30-4—Syntax for edge-sensitive path declaration (excerpt from Annex A)	764
Syntax 30-5—Syntax for state-dependent paths (excerpt from Annex A).....	765
Syntax 30-6—Syntax for path delay value (excerpt from Annex A)	772
Syntax 30-7—Syntax for PATHPULSE\$ pulse control (excerpt from Annex A)	777
Syntax 30-8—Syntax for pulse style declarations (excerpt from Annex A)	779
Syntax 30-9—Syntax for showcanceled declarations (excerpt from Annex A).....	780
Syntax 31-1—Syntax for system timing checks (excerpt from Annex A)	786
Syntax 31-2—Syntax for time check conditions and timing check events (excerpt from Annex A).....	787
Syntax 31-3—Syntax for \$setup (excerpt from Annex A)	788
Syntax 31-4—Syntax for \$hold (excerpt from Annex A)	789
Syntax 31-5—Syntax for \$setuphold (excerpt from Annex A).....	790
Syntax 31-6—Syntax for \$removal (excerpt from Annex A)	792
Syntax 31-7—Syntax for \$recovery (excerpt from Annex A).....	792
Syntax 31-8—Syntax for \$recrem (excerpt from Annex A)	793
Syntax 31-9—Syntax for \$skew (excerpt from Annex A)	795
Syntax 31-10—Syntax for \$timeskew (excerpt from Annex A)	796
Syntax 31-11—Syntax for \$fullskew (excerpt from Annex A).....	799
Syntax 31-12—Syntax for \$width (excerpt from Annex A)	801
Syntax 31-13—Syntax for \$period (excerpt from Annex A)	802

Syntax 31-14—Syntax for \$nochange (excerpt from Annex A)	803
Syntax 31-15—Syntax for edge-control specifier (excerpt from Annex A).....	804
Syntax 31-16—Syntax for controlled timing check events (excerpt from Annex A)	807
Syntax 32-1—Syntax for \$sdf_annotate system task (not in Annex A).....	823
Syntax 33-1—Syntax for cell (excerpt from Annex A).....	826
Syntax 33-2—Syntax for declaring library in library map file (excerpt from Annex A).....	827
Syntax 33-3—Syntax for include command (excerpt from Annex A).....	828
Syntax 33-4—Syntax for configurations (excerpt from Annex A)	829
Syntax 35-1—DPI import declaration syntax (excerpt from Annex A).....	869
Syntax 35-2—DPI export declaration syntax (excerpt from Annex A)	874

INTERNATIONAL ELECTROTECHNICAL COMMISSION

**SystemVerilog –
Unified Hardware Design, Specification,
and Verification Language**

FOREWORD

1) The International Electrotechnical Commission (IEC) is a worldwide organization for standardization comprising all national electrotechnical committees (IEC National Committees). The object of IEC is to promote international co-operation on all questions concerning standardization in the electrical and electronic fields. To this end and in addition to other activities, IEC publishes International Standards, Technical Specifications, Technical Reports, Publicly Available Specifications (PAS) and Guides (hereafter referred to as "IEC Publication(s)"). Their preparation is entrusted to technical committees; any IEC National Committee interested in the subject dealt with may participate in this preparatory work. International, governmental and non-governmental organizations liaising with the IEC also participate in this preparation. IEC collaborates closely with the International Organization for Standardization (ISO) in accordance with conditions determined by agreement between the two organizations.

2) The formal decisions or agreements of IEC on technical matters express, as nearly as possible, an international consensus of opinion on the relevant subjects since each technical committee has representation from all interested IEC National Committees.

3) IEC Publications have the form of recommendations for international use and are accepted by IEC National Committees in that sense. While all reasonable efforts are made to ensure that the technical content of IEC Publications is accurate, IEC cannot be held responsible for the way in which they are used or for any misinterpretation by any end user.

4) In order to promote international uniformity, IEC National Committees undertake to apply IEC Publications transparently to the maximum extent possible in their national and regional publications. Any divergence between any IEC Publication and the corresponding national or regional publication shall be clearly indicated in the latter.

5) IEC itself does not provide any attestation of conformity. Independent certification bodies provide conformity assessment services and, in some areas, access to IEC marks of conformity. IEC is not responsible for any services carried out by independent certification bodies.

6) Attention is drawn to the possibility that some of the elements of this IEC Publication may be the subject of patent rights. IEC shall not be held responsible for identifying any or all such patent rights.

International Standard IEC 62530/IEEE Std 1800 has been processed through IEC technical committee 93: *Design automation*.

This second edition cancels and replaces the first edition published in 2007. This edition constitutes a technical revision.

The text of this standard is based on the following documents:

IEEE Std	FDIS	Report on voting
1800 (2009)	93/303/FDIS	93/305/RVD

Full information on the voting for the approval of this standard can be found in the report on voting indicated in the above table.

The committee has decided that the contents of this publication will remain unchanged until the stability date indicated on the IEC web site under "<http://webstore.iec.ch>" in the data related to the specific publication. At this date, the publication will be

- reconfirmed,
- withdrawn,
- replaced by a revised edition, or
- amended.

IMPORTANT – The 'color inside' logo on the cover page of this publication indicates that it contains colors which are considered to be useful for the correct understanding of its contents. Users should therefore print this document using a color printer.

IEC/IEEE Dual Logo International Standards

This Dual Logo International Standard is the result of an agreement between the IEC and the Institute of Electrical and Electronics Engineers, Inc. (IEEE). The original IEEE Standard was submitted to the IEC for consideration under the agreement, and the resulting IEC/IEEE Dual Logo International Standard has been published in accordance with the ISO/IEC Directives.

IEEE Standards documents are developed within the IEEE Societies and the Standards Coordinating Committees of the IEEE Standards Association (IEEE-SA) Standards Board. The IEEE develops its standards through a consensus development process, approved by the American National Standards Institute, which brings together volunteers representing varied viewpoints and interests to achieve the final product. Volunteers are not necessarily members of the Institute and serve without compensation. While the IEEE administers the process and establishes rules to promote fairness in the consensus development process, the IEEE does not independently evaluate, test, or verify the accuracy of any of the information contained in its standards.

Use of an IEC/IEEE Dual Logo International Standard is wholly voluntary. The IEC and IEEE disclaim liability for any personal injury, property or other damage, of any nature whatsoever, whether special, indirect, consequential, or compensatory, directly or indirectly resulting from the publication, use of, or reliance upon this or any other IEC or IEEE Standard document.

The IEC and IEEE do not warrant or represent the accuracy or content of the material contained herein, and expressly disclaim any express or implied warranty, including any implied warranty of merchantability or fitness for a specific purpose, or that the use of the material contained herein is free from patent infringement. IEC/IEEE Dual Logo International Standards documents are supplied "AS IS".

The existence of an IEC/IEEE Dual Logo International Standard does not imply that there are no other ways to produce, test, measure, purchase, market, or provide other goods and services related to the scope of the IEC/IEEE Dual Logo International Standard. Furthermore, the viewpoint expressed at the time a standard is approved and issued is subject to change brought about through developments in the state of the art and comments received from users of the standard.

Every IEEE Standard is subjected to review at least every five years for revision or reaffirmation. When a document is more than five years old and has not been reaffirmed, it is reasonable to conclude that its contents, although still of some value, do not wholly reflect the present state of the art. Users are cautioned to check to determine that they have the latest edition of any IEEE Standard.

In publishing and making this document available, the IEC and IEEE are not suggesting or rendering professional or other services for, or on behalf of, any person or entity. Neither the IEC nor IEEE is undertaking to perform any duty owed by any other person or entity to another. Any person utilizing this, and any other IEC/IEEE Dual Logo International Standards or IEEE Standards document, should rely upon the advice of a competent professional in determining the exercise of reasonable care in any given circumstances.

Interpretations – Occasionally questions may arise regarding the meaning of portions of standards as they relate to specific applications. When the need for interpretations is brought to the attention of IEEE, the Institute will initiate action to prepare appropriate responses. Since IEEE Standards represent a consensus of concerned interests, it is important to ensure that any interpretation has also received the concurrence of a balance of interests. For this reason, IEEE and the members of its societies and Standards Coordinating Committees are not able to provide an instant response to interpretation requests except in those cases where the matter has previously received formal consideration.

Comments for revision of IEC/IEEE Dual Logo International Standards are welcome from any interested party, regardless of membership affiliation with the IEC or IEEE. Suggestions for changes in documents should be in the form of a proposed change of text, together with appropriate supporting comments. Comments on standards and requests for interpretations should be addressed to:

Secretary, IEEE-SA Standards Board, 445 Hoes Lane, Piscataway, NJ 08854, USA and/or General Secretary, IEC, 3, rue de Varembe, PO Box 131, 1211 Geneva 20, Switzerland.

Authorization to photocopy portions of any individual standard for internal or personal use is granted by the Institute of Electrical and Electronics Engineers, Inc., provided that the appropriate fee is paid to Copyright Clearance Center. To arrange for payment of licensing fee, please contact Copyright Clearance Center, Customer Service, 222 Rosewood Drive, Danvers, MA 01923 USA; +1 978 750 8400. Permission to photocopy portions of any individual standard for educational classroom use can also be obtained through the Copyright Clearance Center.

NOTE – Attention is called to the possibility that implementation of this standard may require use of subject matter covered by patent rights. By publication of this standard, no position is taken with respect to the existence or validity of any patent rights in connection therewith. The IEEE shall not be responsible for identifying patents for which a license may be required by an IEEE standard or for conducting inquiries into the legal validity or scope of those patents that are brought to its attention.

IEEE Standard for SystemVerilog — Unified Hardware Design, Specification, and Verification Language

Sponsor
Design Automation Standards Committee
of the
IEEE Computer Society

and the
IEEE Standards Association Corporate Advisory Group

Approved 11 November 2009
IEEE-SA Standards Board

Abstract: This standard represents a merger of two previous standards: IEEE Std 1364™-2005 Verilog hardware description language (HDL) and IEEE Std 1800-2005 SystemVerilog unified hardware design, specification, and verification language. The 2005 SystemVerilog standard defines extensions to the 2005 Verilog standard. These two standards were designed to be used as one language. Merging the base Verilog language and the SystemVerilog extensions into a single standard provides users with all information regarding syntax and semantics in a single document.

Keywords: assertions, design automation, design verification, hardware description language, HDL, HDVL, PLI, programming language interface, SystemVerilog, Verilog, VPI

IEEE introduction

The purpose of this standard is to provide the electronic design automation (EDA), semiconductor, and system design communities with a well-defined and official IEEE unified hardware design, specification, and verification standard language. The language is designed to coexist and enhance the hardware description and verification languages (HDVLS) presently used by designers while providing the capabilities lacking in those languages.

SystemVerilog is a unified hardware design, specification, and verification language based on the Accellera SystemVerilog 3.1a extensions to the Verilog HDL [B3]^a, published in 2004. Accellera is a consortium of EDA, semiconductor, and system companies. IEEE Std 1800 enables a productivity boost in design and validation and covers design, simulation, validation, and formal assertion-based verification flows.

SystemVerilog enables the use of a unified language for abstract and detailed specification of the design, specification of assertions, coverage, and testbench verification based on manual or automatic methodologies. SystemVerilog offers application programming interfaces (APIs) for coverage and assertions, a vendor-independent API to access proprietary waveform file formats, and a direct programming interface (DPI) to access proprietary functionality. SystemVerilog offers methods that allow designers to continue to use present design languages when necessary to leverage existing designs and intellectual property. This standardization project will provide the VLSI design engineers with a well-defined IEEE standard, which meets their requirements in design and validation, and which enables a step function increase in their productivity. This standardization project will also provide the EDA industry with a standard to which they can adhere and which they can support in order to deliver their solutions in this area.

Notice to users

Laws and regulations

Users of these documents should consult all applicable laws and regulations. Compliance with the provisions of this standard does not imply compliance to any applicable regulatory requirements. Implementers of the standard are responsible for observing or referring to the applicable regulatory requirements. IEEE does not, by the publication of its standards, intend to urge action that is not in compliance with applicable laws, and these documents may not be construed as doing so.

Copyrights

This document is copyrighted by the IEEE. It is made available for a wide variety of both public and private uses. These include both use, by reference, in laws and regulations, and use in private self-regulation, standardization, and the promotion of engineering practices and methods. By making this document available for use and adoption by public authorities and private users, the IEEE does not waive any rights in copyright to this document.

^aThe numbers in brackets correspond to the numbers in the bibliography in [Annex R](#).

Updating of IEEE documents

Users of IEEE standards should be aware that these documents may be superseded at any time by the issuance of new editions or may be amended from time to time through the issuance of amendments, corrigenda, or errata. An official IEEE document at any point in time consists of the current edition of the document together with any amendments, corrigenda, or errata then in effect. In order to determine whether a given document is the current edition and whether it has been amended through the issuance of amendments, corrigenda, or errata, visit the IEEE Standards Association website at <http://ieeexplore.ieee.org/xpl/standards.jsp>, or contact the IEEE at the address listed previously.

For more information about the IEEE Standards Association or the IEEE standards development process, visit the IEEE-SA website at <http://standards.ieee.org>.

Errata

Errata, if any, for this and all other standards can be accessed at the following URL: <http://standards.ieee.org/reading/ieee/updates/errata/index.html>. Users are encouraged to check this URL for errata periodically.

Interpretations

Current interpretations can be accessed at the following URL: <http://standards.ieee.org/reading/ieee/interp/index.html>.

Patents

Attention is called to the possibility that implementation of this amendment may require use of subject matter covered by patent rights. By publication of this amendment, no position is taken with respect to the existence or validity of any patent rights in connection therewith. The IEEE is not responsible for identifying Essential Patent Claims for which a license may be required, for conducting inquiries into the legal validity or scope of Patents Claims or determining whether any licensing terms or conditions provided in connection with submission of a Letter of Assurance, if any, or in any licensing agreements are reasonable or non-discriminatory. Users of this amendment are expressly advised that determination of the validity of any patent rights, and the risk of infringement of such rights, is entirely their own responsibility. Further information may be obtained from the IEEE Standards Association.

IMPORTANT NOTICE: This standard is not intended to ensure safety, security, health, or environmental protection in all circumstances. Implementers of the standard are responsible for determining appropriate safety, security, environmental, and health practices or regulatory requirements.

This IEEE document is made available for use subject to important notices and legal disclaimers. These notices and disclaimers appear in all publications containing this document and may be found under the heading "Important Notice" or "Important Notices and Disclaimers Concerning IEEE Documents." They can also be obtained on request from IEEE or viewed at <http://standards.ieee.org/IPR/disclaimers.html>.

Part One: Design and Verification Constructs

SystemVerilog — Unified Hardware Design, Specification, and Verification Language

1. Overview

1.1 Scope

This SystemVerilog standard (IEEE Std 1800) is a Unified Hardware Design, Specification, and Verification language. IEEE Std 1364™-2005 Verilog is a design language. Both standards were approved by the IEEE-SASB in November 2005. This standard creates new revisions of the IEEE 1364 Verilog and IEEE 1800 SystemVerilog standards, which include errata fixes and resolutions, enhancements, enhanced assertion language, merger of Verilog Language Reference Manual (LRM) and SystemVerilog 1800 LRM into a single LRM, integration with Verilog-AMS, and ensures interoperability with other languages such as SystemC and VHDL.

1.2 Purpose

The purpose of this project is to provide the EDA, Semiconductor, and System Design communities with a solid and well-defined IEEE Unified Hardware Design, Specification and Verification standard language, while resolving errata and developing enhancements to the current IEEE 1800 SystemVerilog standard. The language is designed to co-exist, be interoperable, possibly merge, and enhance those hardware description languages presently used by designers.

1.3 Merger of IEEE Std 1364-2005 and IEEE Std 1800-2005

This standard represents a merger of two previous standards: the IEEE Std 1364-2005¹ Verilog Hardware Description Language (HDL) and the IEEE Std 1800-2005 SystemVerilog Unified Hardware Design, Specification, and Verification Language. In these previous standards, Verilog was the base language and defined a completely self-contained standard. SystemVerilog defined a number of significant extensions to Verilog, but IEEE Std 1800-2005 was not a self-contained standard; IEEE Std 1800-2005 referred to, and relied on, IEEE Std 1364-2005. These two standards were designed to be used as one language. Merging the base Verilog language and the SystemVerilog extensions into a single standard enables users to have all information regarding syntax and semantics in a single document.

This standard serves as a complete specification of the SystemVerilog language. This standard contains the following:

- The formal syntax and semantics of all SystemVerilog constructs
- Simulation system tasks and system functions, such as text output display commands
- Compiler directives, such as text substitution macros and simulation time scaling
- The Programming Language Interface (PLI) mechanism
- The formal syntax and semantics of the SystemVerilog Verification Procedural Interface (VPI)
- An Application Programming Interface (API) for coverage access not included in VPI
- Direct programming interface (DPI) for interoperation with the C programming language
- VPI, API, and DPI header files
- Concurrent assertion formal semantics
- The formal syntax and semantics of standard delay format (SDF) constructs
- Informative usage examples

1.4 Special terms

Throughout this standard, the following terms apply:

- *SystemVerilog* refers to the unified Verilog base language (IEEE Std 1364) with the SystemVerilog extensions to Verilog.
- *SystemVerilog 3.1a* refers to the Accellera SystemVerilog Language Reference Manual [B3],² a precursor to IEEE Std 1800-2005.
- *Verilog* refers to IEEE Std 1364-2005 for the Verilog HDL.
- *Language Reference Manual (LRM)* refers to the document describing a Verilog or SystemVerilog standard.
- *Tool* refers to a software implementation that reads SystemVerilog source code, such as a logic simulator.

NOTE—In the IEEE Std 1800-2005 version of the standard, *SystemVerilog* referred to just the extensions to the IEEE Std 1364-2005 Verilog language, and did not include the Verilog base language.³

1.5 Conventions used in this standard

This standard is organized into clauses, each of which focuses on a specific area of the language. There are subclauses within each clause to discuss individual constructs and concepts. The discussion begins with an

¹Information on references can be found in [Clause 2](#).

²The numbers in brackets correspond to those of the bibliography in [Annex R](#).

³Notes in text, tables, and figures are given for information only and do not contain requirements needed to implement the standard.

introduction and an optional rationale for the construct or the concept, followed by syntax and semantic descriptions, followed by examples and notes.

The terminology conventions used throughout this standard are as follows:

- The word *shall* is used to indicate mandatory requirements strictly to be followed in order to conform to the standard and from which no deviation is permitted (*shall* equals *is required to*).
- The word *should* is used to indicate that among several possibilities one is recommended as particularly suitable, without mentioning or excluding others; or that a certain course of action is preferred but not necessarily required; or that (in the negative form) a certain course of action is deprecated but not prohibited (*should* equals *is recommended that*).
- The word *may* is used to indicate a course of action permissible within the limits of the standard (*may* equals *is permitted to*).
- The word *can* is used for statements of possibility and capability, whether material, physical, or causal (*can* equals *is able to*).

1.6 Syntactic description

The main text uses the following conventions:

- *Italicized* font when a term is being defined
- Constant-width font for examples, file names, and references to constants, especially 0, 1, x, and z values
- **Boldface constant-width** font for SystemVerilog keywords, when referring to the actual keyword

The formal syntax of SystemVerilog is described using Backus-Naur Form (BNF). The following conventions are used:

- Lowercase words, some containing embedded underscores, denote syntactic categories. For example:

```
module_declaration
```

- **Boldface-red** characters denote reserved keywords, operators, and punctuation marks as a required part of the syntax. For example:

```
module => ;
```

- A vertical bar (|) that is not in boldface-red separates alternative items. For example:

```
unary_operator ::=  
+ | - | ! | ~ | & | ~& | | | ~ | ^ | ~^ | ^~
```

- Square brackets ([]) that are not in boldface-red enclose optional items. For example:

```
function_declaration ::= function [ lifetime ] function_body_declaration
```

- Braces ({ }) that are not in boldface-red enclose a repeated item. The item may appear zero or more times; the repetitions occur from left to right as with an equivalent left-recursive rule. Thus, the following two rules are equivalent:

```
list_of_param_assignments ::= param_assignment { , param_assignment }  
list_of_param_assignments ::=  
    param_assignment  
    | list_of_param_assignments , param_assignment
```

A *qualified term* in the syntax is a term such as *array_identifier* for which the “array” portion represents some semantic intent and the “identifier” term indicates that the qualified term reduces to the “identifier” term in the syntax. The syntax does not completely define the semantics of such qualified terms; for example while an identifier which would qualify semantically as an *array_identifier* is created by a declaration, such declaration forms are not explicitly described using *array_identifier* in the syntax.

1.7 Use of color in this standard

This standard uses a minimal amount of color to enhance readability. The coloring is not essential and does not affect the accuracy of this standard when viewed in pure black and white. The places where color is used are the following:

- Cross references that are hyperlinked to other portions of this standard are shown in underlined-blue text (hyperlinking works when this standard is viewed interactively as a PDF file).
- Syntactic keywords and tokens in the formal language definitions are shown in **boldface-red text**.
- Some figures use a minimal amount of color to enhance readability.

1.8 Contents of this standard

A synopsis of the clauses and annexes is presented as a quick reference. All clauses and several of the annexes are normative parts of this standard. Some annexes are included for informative purposes only.

Part One: Design and Verification Constructs

[Clause 1](#) describes the contents of this standard and the conventions used in this standard.

[Clause 2](#) lists references to other standards that are required in order to implement this standard.

[Clause 3](#) introduces the major building blocks that make up a SystemVerilog design and verification environment: modules, programs, interfaces, checkers, packages and configurations. This clause also discusses primitives, name spaces, the `$unit` compilation space, and the concept of simulation time.

[Clause 4](#) describes the SystemVerilog simulation scheduling semantics.

[Clause 5](#) describes the lexical tokens used in SystemVerilog source text and their conventions.

[Clause 6](#) describes SystemVerilog data objects and types, including nets and variables, their declaration syntax and usage rules, and charge strength of the values on nets. This clause also discusses strings and string methods, enumerated types, user-defined types, constants, data scope and lifetime, and type compatibility.

[Clause 7](#) describes SystemVerilog compound data types: structures, unions, arrays, including packed and unpacked arrays, dynamic arrays, associative arrays, and queues. This clause also describes various array methods.

[Clause 8](#) describes the object-oriented programming capabilities in SystemVerilog. Topics include defining classes, dynamically constructing objects, inheritance and subclasses, data hiding and encapsulation, polymorphism, and parameterized classes.

[Clause 9](#) describes the SystemVerilog procedural blocks: **initial**, **always**, **always_comb**, **always_ff**, **always_latch**, and **final**. Sequential and parallel statement grouping, block names, statement labels, and process control are also described.

[Clause 10](#) describes continuous assignments, blocking and nonblocking procedural assignments, and procedural continuous assignments.

[Clause 11](#) describes the operators and operands that can be used in expressions. This clause also discusses operations on arrays, operator methods, and operator overloading.

[Clause 12](#) describes SystemVerilog procedural programming statements, such as decision statements and looping constructs.

[Clause 13](#) describes tasks and functions, which are subroutines that can be called from more than one place in a behavioral model.

[Clause 14](#) defines clocking blocks, input and output skews, cycle delays, and default clocking.

[Clause 15](#) describes interprocess communications using event types and event controls, and built-in semaphore and mailbox classes.

[Clause 16](#) describes immediate and concurrent assertions, properties, sequences, sequence operations, multiclock sequences, and clock resolution.

[Clause 17](#) describes checkers. Checkers allow the encapsulation of assertions and modeling code to create a single verification entity.

[Clause 18](#) describes generating random numbers, constraining random number generation, dynamically changing constraints, seeding random number generators (RNGs), and randomized `case` statement execution.

[Clause 19](#) describes coverage groups, coverage points, cross coverage, coverage options, and coverage methods.

[Clause 20](#) describes most of the built-in system tasks and system functions.

[Clause 21](#) describes additional system tasks and system functions that are specific to I/O operations.

[Clause 22](#) describes various compiler directives, including a directive for controlling reserved keyword compatibility between versions of previous Verilog and SystemVerilog standards.

Part Two: Hierarchy Constructs

[Clause 23](#) describes how hierarchies are created in SystemVerilog using module instances and interface instances, and port connection rules. This clause also discusses the \$root top-level instances, nested modules, extern modules, identifier search rules, how parameter values can be overridden, and binding auxiliary code to scopes or instances.

[Clause 24](#) describes the testbench program construct, the elimination of testbench race conditions, and program control tasks.

[Clause 25](#) describes interface syntax, interface ports, modports, interface subroutines, parameterized interfaces, virtual interfaces, and accessing objects within interfaces.

[Clause 26](#) describes user-defined packages and the std built-in package.

[Clause 27](#) describes the generate construct and how generated constructs can be used to do conditional or multiple instantiations of procedural code or hierarchy.

[Clause 28](#) describes the gate- and switch-level primitives and logic strength modeling.

[Clause 29](#) describes how a User Defined Primitive (UDP) can be defined and how these primitives are included in SystemVerilog models.

[Clause 30](#) describes how to specify timing relationships between input and output ports of a module.

[Clause 31](#) describes how timing checks are used in specify blocks to determine whether signals obey the timing constraints.

[Clause 32](#) describes the syntax and semantics of SDF constructs.

[Clause 33](#) describes how to configure the contents of a design.

[Clause 34](#) describes encryption and decryption of source text regions.

Part Three: Application Programming Interfaces (APIs)

[Clause 35](#) describes SystemVerilog's direct programming interface (DPI), a direct interface to foreign languages and the syntax for importing functions from a foreign language and exporting subroutines to a foreign language.

[Clause 36](#) provides an overview of the Programming Language Interface (PLI and VPI).

[Clause 37](#) presents the VPI data model diagrams, which document the VPI object relationships and access methods.

[Clause 38](#) describes the VPI routines.

[Clause 39](#) describes the assertion API in SystemVerilog.

[Clause 40](#) describes the coverage API in SystemVerilog.

Part Four: Annexes

[Annex A](#) (normative) defines the formal syntax of SystemVerilog, using BNF.

[Annex B](#) (normative) lists the SystemVerilog keywords.

[Annex C](#) (informative) lists constructs that have been deprecated from SystemVerilog. The annex also discusses the possible deprecation of the `defparam` statement and the procedural `assign/deassign` statements.

[Annex D](#) (informative) describes system tasks and system functions that are frequently used, but that are not required in this standard.

[Annex E](#) (informative) describes compiler directives that are frequently used, but that are not required in this standard.

[Annex F](#) (normative) describes a formal semantics for SystemVerilog concurrent assertions.

[Annex G](#) (normative) describes the SystemVerilog standard package, containing type definitions for mailbox, semaphore, randomize, and process.

[Annex H](#) (normative) defines the C-language layer for the SystemVerilog DPI.

[Annex I](#) (normative) defines the standard `svdpi.h` include file for use with SystemVerilog DPI applications.

[Annex J](#) (normative) describes common guidelines for the inclusion of foreign language code into a SystemVerilog application.

[Annex K](#) (normative) provides a listing of the contents of the `vpi_user.h` file.

[Annex L](#) (normative) provides a listing of the contents of the `vpi_compatibility.h` file, which extends the `vpi_user.h` include file.

[Annex M](#) (normative) provides a listing of the contents of the `sv_vpi_user.h` file, which extends the `vpi_user.h` include file.

[Annex N](#) (normative) provides the C source code for the SystemVerilog random distribution system functions.

[Annex O](#) (informative) describes various scenarios that can be used for intellectual property (IP) protection, and it also shows how the relevant pragmas can be used to achieve the desired effect of securely protecting, distributing, and decrypting the model.

[Annex P](#) (informative) defines terms that are used in this standard.

[Annex Q](#) (informative) provides a general mapping of clause numbers from IEEE Std 1364-2005 Verilog standard and IEEE Std 1800-2005 SystemVerilog standard into this standard.

[Annex R](#) (informative) lists reference documents that are related to this standard.

1.9 Deprecated clauses

[Annex C](#) lists constructs that appeared in previous versions of either IEEE Std 1364 or IEEE Std 1800, but that have been deprecated and do not appear in this standard. This annex also lists constructs that appear in this standard, but that are under consideration for deprecation in a future version of this standard.

1.10 Examples

Small SystemVerilog code examples are shown throughout this standard. These examples are informative. They are intended to illustrate the usage of SystemVerilog constructs in a simple context and do not define the full syntax.

1.11 Prerequisites

Some clauses of this standard presuppose a working knowledge of the C programming language.

2. Normative references

The following referenced documents are indispensable for the application of this standard (i.e., they must be understood and used, so each referenced document is cited in the text and its relationship to this document is explained). For dated references, only the edition cited applies. For undated references, the latest edition of the referenced document (including any amendments or corrigenda) applies.

Anderson, R., Biham, E., and Knudsen, L. "Serpent: A Proposal for the Advanced Encryption Standard," NIST AES Proposal, 1998, <http://www.cl.cam.ac.uk/~rja14/Papers/serpent.tar.gz>.

ANSI Std X9.52-1998, American National Standard for Financial Services—Triple Data Encryption Algorithm Modes of Operation.⁴

ElGamal, T., "A Public-Key Cryptosystem and a Signature Scheme Based on Discrete Logarithms," *IEEE Transactions on Information Theory*, vol. IT-31, no. 4, pp. 469–472, July 1985.

FIPS 46-3 (October 1999), Data Encryption Standard (DES).⁵

FIPS 180-2 (August 2002), Secure Hash Standard (SHS).

FIPS 197 (November 2001), Advanced Encryption Standard (AES).

IEC 62530:2007, Standard for SystemVerilog—Unified Hardware Design, Specification, and Verification Language. †

IEEE Std 1800™-2005, IEEE Standard for SystemVerilog—Unified Hardware Design, Specification, and Verification Language.

NOTE—IEEE Std 1800™-2005 was adopted as IEC 62530:2007.

IEEE Std 754™, IEEE Standard for Binary Floating-Point Arithmetic.^{6, 7}

IEEE Std 1003.1™, IEEE Standard for Information Technology—Portable Operating System Interface (POSIX®).

IEEE Std 1364™-1995, IEEE Standard Hardware Description Language Based on the Verilog™ Hardware Description Language.

IEEE Std 1364™-2001, IEEE Standard for Verilog Hardware Description Language.

IEEE Std 1364™-2005, IEEE Standard for Verilog Hardware Description Language.

IETF RFC 1319 (April 1992), The MD2 Message-Digest Algorithm.⁸

IETF RFC 1321 (April 1992), The MD5 Message-Digest Algorithm.

IETF RFC 2045 (November 1996), Multipurpose Internet Mail Extensions (MIME), Part One: Format of Internet Message Bodies.

IETF RFC 2144 (May 1997), The CAST-128 Encryption Algorithm.

⁴ANSI publications are available from the Sales Department, American National Standards Institute, 25 West 43rd Street, 4th Floor, New York, NY 10036, USA (<http://www.ansi.org/>).

⁵FIPS publications are available from the National Technical Information Service (NTIS), U. S. Dept. of Commerce, 5285 Port Royal Rd., Springfield, VA 22161 (<http://www.ntis.org/>).

⁶IEEE publications are available from the Institute of Electrical and Electronics Engineers, 445 Hoes Lane, Piscataway, NJ 08854, USA (<http://standards.ieee.org/>).

⁷The IEEE standards or products referred to in this clause are trademarks of the Institute of Electrical and Electronics Engineers, Inc.

⁸IETF requests for comments (RFCs) are available from the Internet Engineering Task Force (<http://www.ietf.org/>).

IETF RFC 2437 (October 1998), PKCS #1: RSA Cryptography Specifications, Version 2.0.

IETF RFC 2440 (November 1998), OpenPGP Message Format.

ISO/IEC 10118-3:2004, Information technology—Security techniques—Hash-functions—Part 3: Dedicated hash-functions.⁹

Schneier, B., “Description of a New Variable-Length Key, 64-Bit Block Cipher (Blowfish),” *Fast Software Encryption, Cambridge Security Workshop Proceedings (December 1993)*, Springer-Verlag, 1994, pp. 191–204.

Schneier, B., et al, *The Twofish Encryption Algorithm: A 128-Bit Block Cipher*, 1st ed., Wiley, 1999.

⁹ISO/IEC publications are available from the ISO Central Secretariat, Case Postale 56, 1 chemin de la Voie-Creuse, CH-1211 Genève 20, Switzerland/Suisse (<http://www.iso.ch/>) and from the IEC Central Office, Case Postale 131, 3 rue de Varembe, CH-1211 Genève 20, Switzerland/Suisse (<http://www.iec.ch/>). ISO/IEC publications are also available in the United States from Global Engineering Documents, 15 Inverness Way East, Englewood, Colorado 80112, USA (<http://global.ihs.com/>). Electronic copies are available in the United States from the American National Standards Institute, 25 West 43rd Street, 4th Floor, New York, NY 10036, USA (<http://www.ansi.org/>).

3. Design and verification building blocks

3.1 General

This clause describes the following:

- The purpose of modules, programs, interfaces, checkers, and primitives
- An overview of subroutines
- An overview of packages
- An overview of configurations
- An overview of design hierarchy
- Definition of compilation and elaboration
- Declaration name spaces
- Simulation time, time units, and time precision

This clause defines several important SystemVerilog terms and concepts that are used throughout this document. The clause also provides an overview of the purpose and usage of the modeling blocks used to represent a hardware design and its verification environment.

3.2 Design elements

A *design element* is a SystemVerilog module (see [Clause 23](#)), program (see [Clause 24](#)), interface (see [Clause 25](#)), checker (see [Clause 17](#)), package (see [Clause 26](#)), primitive (see [Clause 28](#)) or configuration (see [Clause 33](#)). These constructs are introduced by the keywords **module**, **program**, **interface**, **checker**, **package**, **primitive**, and **config**, respectively.

Design elements are the primary building blocks used to model and build up a design and verification environment. These building blocks are the containers for the declarations and procedural code that are discussed in subsequent clauses of this document.

This clause describes the purpose of these building blocks. Full details on the syntax and semantics of these blocks are defined in later clauses of this standard.

3.3 Modules

The basic building block in SystemVerilog is the module, enclosed between the keywords **module** and **endmodule**. Modules are primarily used to represent design blocks, but can also serve as containers for verification code and interconnections between verification blocks and design blocks. Some of the constructs that modules can contain include the following:

- Ports, with port declarations
- Data declarations, such as nets, variables, structures, and unions
- Constant declarations
- User-defined type definitions
- Class definitions
- Imports of declarations from packages
- Subroutine definitions
- Instantiations of other modules, interfaces, programs, interfaces, checkers, and primitives
- Instantiations of class objects
- Continuous assignments

- Procedural blocks
- Generate blocks
- Specify blocks

Each of the constructs in the list above is discussed in detail in subsequent clauses of this standard.

NOTE—The list above is not all inclusive. Modules can contain additional constructs, which are also discussed in subsequent clauses of this standard.

Following is a simple example of a module that represents a 2-to-1 multiplexer.

```
module mux2to1 (input wire a, b, sel, // combined port and type declaration
               output logic y);

    always_comb begin // procedural block
        if (sel) y = a; // procedural statement
        else     y = b;
    end
endmodule: mux2to1
```

Modules are presented in more detail in [Clause 23](#). See also [3.11](#) on creating design hierarchy with modules.

3.4 Programs

The program building block is enclosed between the keywords **program...endprogram**. This construct is provided for modeling the testbench environment. The module construct works well for the description of hardware. However, for the testbench, the emphasis is not on the hardware-level details such as wires, structural hierarchy, and interconnects, but in modeling the complete environment in which a design is verified.

The program block serves the following three basic purposes:

- It provides an entry point to the execution of testbenches.
- It creates a scope that encapsulates program-wide data, tasks, and functions.
- It provides a syntactic context that specifies scheduling in the Reactive region.

The program construct serves as a clear separator between design and testbench, and, more importantly, it specifies specialized simulation execution semantics. Together with **clocking** blocks (see [Clause 14](#)), the program construct provides for race-free interaction between the design and the testbench and enables cycle- and transaction-level abstractions.

A program block can contain data declarations, class definitions, subroutine definitions, object instances, and one or more initial or final procedures. It cannot contain always procedures, primitive instances, module instances, interface instances, or other program instances.

The abstraction and modeling constructs of SystemVerilog simplify the creation and maintenance of testbenches. The ability to instantiate and individually connect each program instance enables their use as generalized models.

A sample program declaration is as follows:

```
program test (input clk, input [16:1] addr, inout [7:0] data);
    initial begin
        ...
    endprogram
```

The program construct is discussed more fully in [Clause 24](#).

3.5 Interfaces

The interface construct, enclosed between the keywords **interface...endinterface**, encapsulates the communication between design blocks, and between design and verification blocks, allowing a smooth migration from abstract system-level design through successive refinement down to lower level register-transfer and structural views of the design. By encapsulating the communication between blocks, the interface construct also facilitates design reuse.

At its lowest level, an interface is a named bundle of nets or variables. The interface is instantiated in a design and can be connected to interface ports of other instantiated modules, interfaces and programs. An interface can be accessed through a port as a single item, and the component nets or variables referenced where needed. A significant proportion of a design often consists of port lists and port connection lists, which are just repetitions of names. The ability to replace a group of names by a single name can significantly reduce the size of a description and improve its maintainability.

Additional power of the interface comes from its ability to encapsulate functionality as well as connectivity, making an interface, at its highest level, more like a class template. An interface can have parameters, constants, variables, functions, and tasks. The types of elements in an interface can be declared, or the types can be passed in as parameters. The member variables and functions are referenced relative to the instance name of the interface as instance members. Thus, modules that are connected via an interface can simply call the subroutine members of that interface to drive the communication. With the functionality thus encapsulated in the interface and isolated from the module, the abstraction level and/or granularity of the communication protocol can be easily changed by replacing the interface with a different interface containing the same members, but implemented at a different level of abstraction. The modules connected via the interface do not need to change at all.

To provide direction information for module ports and to control the use of subroutines within particular modules, the **modport** construct is provided. As the name indicates, the directions are those seen from the module.

In addition to subroutine methods, an interface can also contain processes (i.e., initial or always procedures) and continuous assignments, which are useful for system-level modeling and testbench applications. This allows the interface to include, for example, its own protocol checker, which automatically verifies that all modules connected via the interface conform to the specified protocol. Other applications, such as functional coverage recording and reporting, protocol checking, and assertions can also be built into the interface.

A simple example of an interface definition and usage is as follows:

```

interface simple_bus(input logic clk); // Define the interface
    logic req, gnt;
    logic [7:0] addr, data;
    logic [1:0] mode;
    logic start, rdy;
endinterface: simple_bus

module memMod(simple_bus a); // simple_bus interface port
    logic avail;
    // When memMod is instantiated in module top, a.req is the req
    // signal in the sb_intf instance of the 'simple_bus' interface
    always @(posedge clk) a.gnt <= a.req & avail;
endmodule

module cpuMod(simple_bus b); // simple_bus interface port
    ...
endmodule

```

```
module top;
  logic clk = 0;

  simple_bus sb_intf(.clk(clk)); // Instantiate the interface

  memMod mem(.a(sb_intf)); // Connect interface to module instance
  cpuMod cpu(.b(sb_intf)); // Connect interface to module instance

endmodule
```

See [Clause 25](#) for a full description of interfaces.

3.6 Checkers

The checker construct, enclosed by the keywords **checker...endchecker**, represents a verification block encapsulating assertions along with the modeling code. The intended use of checkers is to serve as verification library units, or as building blocks for creating abstract auxiliary models used in formal verification. The checker construct is discussed in detail in [Clause 17](#).

3.7 Primitives

The *primitive* building block is used to represent low-level logic gates and switches. SystemVerilog includes a number of built-in primitive types. Designers can supplement the built-in primitives with *user-defined primitives* (UDPs). A user-defined primitive is enclosed between the keywords **primitive...endprimitive**. The built-in and user-defined primitive constructs allow modeling timing-accurate digital circuits, commonly referred to as *gate-level models*. Gate-level modeling is discussed more fully in [Clause 28](#) through [Clause 31](#).

3.8 Subroutines

Subroutines provide a mechanism to encapsulate executable code that can be invoked from one or more places. There are two forms of subroutines, tasks ([13.3](#)) and functions ([13.4](#)).

A task is called as a statement. A task can have any number of input, output, inout, and ref arguments, but does not return a value. Tasks can block simulation time during execution. That is, the task exit can occur at a later simulation time than when the task was called.

A function can return a value or can be defined as a void function, which does not return a value. A nonvoid function call is used as an operand within an expression. A void function is called as a statement. A function can have input, output, inout, and ref arguments. Functions must execute without blocking simulation time, but can fork off processes that do block time.

3.9 Packages

Modules, interfaces, programs, and checkers provide a local name space for declarations. Identifiers declared within a module, interface, program, or checker are local to that scope, and do not affect or conflict with declarations in other building blocks.

Packages provide a declaration space, which can be shared by other building blocks. Package declarations can be imported into other building blocks, including other packages.

A package is defined between the keywords `package...endpackage`. For example:

```

package ComplexPkg;
  typedef struct {
    shortreal i, r;
  } Complex;

  function Complex add(Complex a, b);
    add.r = a.r + b.r;
    add.i = a.i + b.i;
  endfunction

  function Complex mul(Complex a, b);
    mul.r = (a.r * b.r) - (a.i * b.i);
    mul.i = (a.r * b.i) + (a.i * b.r);
  endfunction
endpackage : ComplexPkg

```

The full syntax and semantics of packages are described in [Clause 26](#).

3.10 Configurations

SystemVerilog provides the ability to specify design configurations, which specify the binding information of module instances to specific SystemVerilog source code. Configurations utilize libraries. A library is a collection of modules, interfaces, programs, checkers, primitives, packages, and other configurations. Separate library map files specify the source code location for the cells contained within the libraries. The names of the library map files are typically specified as invocation options to simulators or other software tools reading in SystemVerilog source code.

See [Clause 33](#) for details of configurations.

3.11 Overview of hierarchy

The basic building blocks of modules, programs, interfaces, checkers, and primitives are used to build up a *design hierarchy*. Hierarchy is created by one building block *instantiating* another building block. When a module contains an *instance* of another module, interface, program, or checker, a new level of hierarchy is created. Communication through levels of hierarchy is primarily through connections to the ports of the instantiated module, interface, program, or checker.

Following is a simple example of two module declarations that utilize some simple declarations. Module `top` contains an instance of module `mux2to1`, creating a design with two levels of hierarchy.

```

module top;    // module with no ports
  logic in1, in2, select;    // variable declarations
  wire out1;    // net declaration

  mux2to1 m1 (.a(in1), .b(in2), .sel(select), .y(out1)); // module instance

endmodule: top

module mux2to1 (input wire a, b, sel, // combined port and type declaration
               output logic y);
  // netlist using built-in primitive instances
  not g1 (sel_n, sel);
  and g2 (a_s, a, sel_n);

```

```
    and g3 (b_s, b, sel);  
    or  g4 (y, a_s, b_s);  
endmodule: mux2to1
```

Modules can instantiate other modules, programs, interfaces, checkers, and primitives, creating a hierarchy tree. Interfaces can also instantiate other building blocks and create a hierarchy tree. Programs and checkers can instantiate other checkers. Primitives cannot instantiate other building blocks; they are leaves in a hierarchy tree.

Normally, a module or program that is elaborated but not explicitly instantiated is implicitly instantiated once at the top of the hierarchy tree and becomes a *top-level hierarchy block* (see [23.3](#) and [24.3](#)). SystemVerilog permits multiple top-level blocks.

Identifiers within any level of hierarchy can be referenced from any other level of hierarchy using *hierarchical path names* (see [23.6](#)).

Instantiation syntax and design hierarchy are presented in more detail in [Clause 23](#).

3.12 Compilation and elaboration

Compilation is the process of reading in SystemVerilog source code, decrypting encrypted code, and analyzing the source code for syntax and semantic errors. Implementations may execute compilation in one or more passes. Implementations may save compiled results in a proprietary intermediate format, or may pass the compiled results directly to an elaboration phase. Not all syntax and semantics can be checked during the compilation process. Some checking can only be done during or at the completion of elaboration.

SystemVerilog supports both single file and multiple file compilation through the use of compilation units (see [3.12.1](#)).

Elaboration is the process of binding together the components that make up a design. These components can include module instances, program instances, interface instances, checker instances, primitive instances, and the top level of the design hierarchy. Elaboration occurs after parsing the source code and before simulation; and it involves expanding instantiations, computing parameter values, resolving hierarchical names, establishing net connectivity and in general preparing the design for simulation. See [23.10.4](#) for additional details on the elaboration process.

Although this standard defines the results of compilation and elaboration, the compilation and elaboration steps are not required to be distinct phases in an implementation. Throughout this standard the terms compilation, compile and compiler normally refer to the combined compilation and elaboration process. So, for example, when the standard refers to a “compile time error,” an implementation is permitted to report the error at any time prior to the start of simulation.

This standard does not normally specify requirements regarding the order of compilation for design elements. The two exceptions are the rules regarding “compilation units” (see [3.12.1](#)) where actual file boundaries during compilation are significant, and the rules regarding references to package items (see [26.3](#)) where the compilation of a package is required to precede references to it.

3.12.1 Compilation units

SystemVerilog supports separate compilation using compiled units. The following terms and definitions are provided:

- **compilation unit:** A collection of one or more SystemVerilog source files compiled together.

- **compilation-unit scope:** A scope that is local to the compilation unit. It contains all declarations that lie outside any other scope.
- **Sunit:** The name used to explicitly access the identifiers in the compilation-unit scope.

The exact mechanism for defining which files constitute a compilation unit is tool-specific. However, compliant tools shall provide use models that allow both of the following cases:

- a) All files on a given compilation command line make a single compilation unit (in which case the declarations within those files are accessible following normal visibility rules throughout the entire set of files).
- b) Each file is a separate compilation unit (in which case the declarations in each compilation-unit scope are accessible only within its corresponding file).

The contents of files included using one or more `#include` directives become part of the compilation unit of the file within which they are included.

If there is a declaration that is incomplete at the end of a file, then the compilation unit including that file will extend through each successive file until there are no incomplete declarations at the end of the group of files.

There are other possible mappings of files to compilation units, and the mechanisms for defining them are tool-specific and may not be portable.

Although the compilation-unit scope is not a package, it can contain any item that can be defined within a package (see [26.2](#)), and bind constructs as well (see [23.11](#)). These items are in the compilation-unit scope name space (see [3.13](#)).

The following items are visible in all compilation units: modules, primitives, programs, interfaces, and packages. Items defined in the compilation-unit scope cannot be accessed by name from outside the compilation unit. The items in a compilation-unit scope can be accessed using the PLI, which must provide an iterator to traverse all the compilation units.

Items in a compilation-unit scope can have hierarchical references to identifiers. For upwards name referencing (see [23.8](#)), the compilation-unit scope is treated like a top-level design unit. This means that if these are not references to identifiers created within the compilation-unit scope or made visible by import of a package into the compilation unit scope, they are treated as full path names starting at the top of the design (`$root`, described in [23.3.1](#)).

Within a separately compiled unit, compiler directives once seen by a tool apply to all subsequent source text. However, compiler directives from one separately compiled unit shall not affect other compilation units. This may result in a difference of behavior between compiling the units separately or as a single compilation unit containing the entire source.

When an identifier is referenced within a scope

- First, the nested scope is searched (see [23.9](#)) (including nested module declarations), including any identifiers made available through package import declarations.
- Next, the portion of the compilation-unit scope defined prior to the reference is searched (including any identifiers made available through package import declarations).
- Finally, if the identifier follows hierarchical name resolution rules, the instance hierarchy is searched (see [23.8](#) and [23.9](#)).

`$unit` is the name of the scope that encompasses a compilation unit. Its purpose is to allow the unambiguous reference to declarations at the outermost level of a compilation unit (i.e., those in the

compilation-unit scope). This is done via the same scope resolution operator used to access package items (see [26.3](#)).

For example:

```
bit b;
task t;
  int b;
  b = 5 + $unit::b;    // $unit::b is the one outside
endtask
```

Other than for task and function names (see [23.8.1](#)), references shall only be made to names already defined in the compilation unit. The use of an explicit `$unit::` prefix only provides for name disambiguation and does not add the ability to refer to later compilation unit items.

For example:

```
task t;
  int x;
  x = 5 + b;           // illegal - "b" is defined later
  x = 5 + $unit::b;   // illegal - $unit adds no special forward referencing
endtask
bit b;
```

The compilation-unit scope allows users to easily share declarations (e.g., types) across the unit of compilation, but without having to declare a package from which the declarations are subsequently imported. Because it has no name, the compilation-unit scope cannot be used with an import declaration, and the identifiers declared within the scope are not accessible via hierarchical references. Within a particular compilation unit, however, the special name `$unit` can be used to explicitly access the declarations of its compilation-unit scope.

3.13 Name spaces

SystemVerilog has eight name spaces for identifiers: two are global (definitions name space and package name space), two are global to the compilation unit (compilation unit name space and text macro name space), and four are local. The eight name spaces are described as follows:

- a) The *definitions name space* unifies all the non-nested **module**, **primitive**, **program**, and **interface** identifiers defined outside all other declarations. Once a name is used to define a module, primitive, program, or interface within one compilation unit, the name shall not be used again (in any compilation unit) to declare another non-nested module, primitive, program, or interface outside all other declarations.
- b) The *package name space* unifies all the **package** identifiers defined among all compilation units. Once a name is used to define a package within one compilation unit, the name shall not be used again to declare another package within any compilation unit.
- c) The *compilation-unit scope name space* exists outside the **module**, **interface**, **package**, **checker**, **program**, and **primitive** constructs. It unifies the definitions of the functions, tasks, checkers, parameters, named events, net declarations, variable declarations, and user-defined types within the compilation-unit scope.
- d) The *text macro name space* is global within the compilation unit. Because text macro names are introduced and used with a leading ``` character, they remain unambiguous with any other name space. The text macro names are defined in the linear order of appearance in the set of input files that make up the compilation unit. Subsequent definitions of the same name override the previous definitions for the balance of the input files.

- e) The *module name space* is introduced by the **module**, **interface**, **package**, **program**, **checker**, and **primitive** constructs. It unifies the definition of modules, interfaces, programs, checkers, functions, tasks, named blocks, instance names, parameters, named events, net declarations, variable declarations, and user-defined types within the enclosing construct.
- f) The *block name space* is introduced by named or unnamed blocks, the **specify**, **function**, and **task** constructs. It unifies the definitions of the named blocks, functions, tasks, parameters, named events, variable type of declaration, and user-defined types within the enclosing construct.
- g) The *port name space* is introduced by the **module**, **interface**, **primitive**, and **program** constructs. It provides a means of structurally defining connections between two objects that are in two different name spaces. The connection can be unidirectional (either **input** or **output**) or bidirectional (**inout** or **ref**). The port name space overlaps the module and the block name spaces. Essentially, the port name space specifies the type of connection between names in different name spaces. The port type of declarations includes **input**, **output**, **inout**, and **ref**. A port name introduced in the port name space can be reintroduced in the module name space by declaring a variable or a net with the same name as the port name.
- h) The *attribute name space* is enclosed by the (* and *) constructs attached to a language element (see 5.12). An attribute name can be defined and used only in the attribute name space. Any other type of name cannot be defined in this name space.

Within a name space, it shall be illegal to redeclare a name already declared by a prior declaration.

3.14 Simulation time units and precision

An important aspect of simulation is time. The term *simulation time* is used to refer to the time value maintained by the simulator to model the actual time it would take for the system description being simulated. The term *time* is used interchangeably with simulation time.

Time values are used in design elements to represent propagation delays and the amount of simulation time between when procedural statements execute. Time values have two components, a *time unit* and a *time precision*.

- The *time unit* represents the unit of measurement for times and delays, and can be specified in units ranging from 100 second units down to 1 femtosecond units.
- The *time precision* specifies the degree of accuracy for delays.

Both the time units and time precision are represented using one of the character strings: *s*, *ms*, *us*, *ns*, *ps*, and *fs* with an order of magnitude of 1, 10, or 100. The definition of these character strings is given in [Table 3-1](#).

Table 3-1—Time unit strings

Character string	Unit of measurement
s	seconds
ms	milliseconds
us	microseconds
ns	nanoseconds
ps	picoseconds
fs	femtoseconds

NOTE—While *s*, *ms*, *ns*, *ps*, and *fs* are the usual SI unit symbols for second, millisecond, nanosecond, picosecond, and femtosecond, due to lack of the Greek letter μ (*mu*) in coding character sets, ‘*us*’ represents the SI unit symbol for microsecond, properly μ s.

The time precision of a design element shall be at least as precise as the time unit; it cannot be a longer unit of time than the time unit.

3.14.1 Time value rounding

Within a design element, such as a module, program or interface, the time precision specifies how delay values are rounded before being used in simulation.

The time precision is relative to the time units. If the precision is the same as the time units, then delay values are rounded off to whole numbers (integers). If the precision is one order of magnitude smaller than the time units, then delay values are rounded off to one decimal place. For example, if the time unit specified is 1ns and the precision is 100ps, then delay values are rounded off to one decimal place (1ps is equivalent to 0.1ns). Thus, a delay of 2.75ns would be rounded off to 2.8ns.

The time values in a design element are accurate to within the unit of time precision specified for that design element, even if there is a smaller time precision specified elsewhere in the design.

3.14.2 Specifying time units and precision

The time unit and time precision can be specified in two ways:

- Using the compiler directive ``timescale`
- Using the keywords `timeunit` and `timeprecision`

3.14.2.1 The ``timescale` compiler directive

The ``timescale` compiler directive specifies the default time unit and precision for all design elements that follow this directive and that do not have `timeunit` and `timeprecision` constructs specified within the design element. The ``timescale` directive remains in effect from when it is encountered in the source code until another ``timescale` compiler directive is read. The ``timescale` directive only affects the current compilation unit; it does not span multiple compilation units (see [3.12.1](#)).

The general syntax for the ``timescale` directive is (see [22.7](#) for more details):

```
`timescale time_unit / time_precision
```

The following example specifies a time unit of 1ns with a precision of 10 ps (2 decimal places of accuracy). The compiler directive affects both module A and B. A second ``timescale` directive replaces the first directive, specifying a time unit of 1 ps and precision of 1 ps (zero decimal places of accuracy) for module C.

```
`timescale 1 ns / 10 ps
module A (...);
...
endmodule

module B (...);
...
endmodule

`timescale 1ps/1ps
module C (...);
...
endmodule
```

The ``timescale` directive can result in file order dependency problems. If the three modules above were compiled in the order of A, B, C (as shown) then module B would simulate with time units in nanoseconds. If the same three files were compiled in the order of C, B, A then module would simulate with time units in picoseconds. This could cause very different simulation results, depending on the time values specified in module B.

3.14.2.2 The `timeunit` and `timeprecision` keywords

The time unit and precision can be declared by the `timeunit` and `timeprecision` keywords, respectively, and set to a time literal (see 5.8). The time precision may also be declared using an optional second argument to the `timeunit` keyword using the slash separator. For example:

```

module D (...);
    timeunit 100ps;
    timeprecision 10fs;
    ...
endmodule

module E (...);
    timeunit 100ps / 10fs; // timeunit with optional second argument
    ...
endmodule

```

Defining the `timeunit` and `timeprecision` constructs within the design element removes the file order dependency problems with compiler directives.

There shall be at most one time unit and one time precision for any module, program, package, or interface definition or in any compilation-unit scope. This shall define a time scope. If specified, the `timeunit` and `timeprecision` declarations shall precede any other items in the current time scope. The `timeunit` and `timeprecision` declarations can be repeated as later items, but must match the previous declaration within the current time scope.

3.14.2.3 Precedence of `timeunit`, `timeprecision` and ``timescale`

If a `timeunit` is not specified within a module, program, package, or interface definition, then the time unit shall be determined using the following rules of precedence:

- a) If the module or interface definition is nested, then the time unit shall be inherited from the enclosing module or interface (programs and packages cannot be nested).
- b) Else, if a ``timescale` directive has been previously specified (within the compilation unit), then the time unit shall be set to the units of the last ``timescale` directive.
- c) Else, if the compilation-unit scope specifies a time unit (outside all other declarations), then the time unit shall be set to the time units of the compilation unit.
- d) Else, the default time unit shall be used.

The time unit of the compilation-unit scope can only be set by a `timeunit` declaration, not a ``timescale` directive. If it is not specified, then the default time unit shall be used.

If a `timeprecision` is not specified in the current time scope, then the time precision shall be determined following the same precedence as with time units.

The default time unit and precision are implementation-specific.

It shall be an error if some design elements have a time unit and precision specified and others do not.

3.14.3 Simulation time unit

The *global time precision*, also called the *simulation time unit*, is the minimum of all the `timeprecision` statements, all the time precision arguments to `timeunit` declarations, and the smallest time precision argument of all the `timescale` compiler directives in the design.

The `step` time unit is equal to the global time precision. Unlike other time units, which represent physical units, a `step` cannot be used to set or modify either the precision or the time unit.

4. Scheduling semantics

4.1 General

This clause describes the following:

- Event-based simulation scheduling semantics
- SystemVerilog's stratified event scheduling algorithm
- Determinism and nondeterminism of event ordering
- Possible sources of race conditions
- PLI callback control points

4.2 Execution of a hardware model and its verification environment

The balance of the clauses of this standard describe the behavior of each of the elements of the language. This clause gives an overview of the interactions between these elements, especially with respect to the scheduling and execution of events.

The elements that make up the SystemVerilog language can be used to describe the behavior, at varying levels of abstraction, of electronic hardware. SystemVerilog is a parallel programming language. The execution of certain language constructs is defined by parallel execution of blocks or processes. It is important to understand what execution order is guaranteed to the user and what execution order is indeterminate.

Although SystemVerilog is used for more than simulation, the semantics of the language are defined for simulation, and everything else is abstracted from this base definition.

4.3 Event simulation

The SystemVerilog language is defined in terms of a discrete event execution model. The discrete event simulation is described in more detail in this clause to provide a context to describe the meaning and valid interpretation of SystemVerilog constructs. These resulting definitions provide the standard SystemVerilog reference algorithm for simulation, which all compliant simulators shall implement. Within the following event execution model definitions, there is a great deal of choice, and differences in some details of execution are to be expected between different simulators. In addition, SystemVerilog simulators are free to use different algorithms from those described in this clause, provided the user-visible effect is consistent with the reference algorithm.

A SystemVerilog description consists of connected threads of execution or processes. Processes are objects that can be evaluated, that can have state, and that can respond to changes on their inputs to produce outputs. Processes are concurrently scheduled elements, such as **initial** procedures. Example of processes include, but are not limited to, primitives; **initial**, **always**, **always_comb**, **always_latch**, and **always_ff** procedures; continuous assignments; asynchronous tasks; and procedural assignment statements.

Every change in state of a net or variable in the system description being simulated is considered an *update event*.

Processes are sensitive to update events. When an update event is executed, all the processes that are sensitive to that event are considered for evaluation in an arbitrary order. The evaluation of a process is also an event, known as an *evaluation event*.

Evaluation events also include PLI callbacks, which are points in the execution model where PLI application routines can be called from the simulation kernel.

In addition to events, another key aspect of a simulator is time. The term *simulation time* is used to refer to the time value maintained by the simulator to model the actual time it would take for the system description being simulated. The term *time* is used interchangeably with *simulation time* in this clause.

To fully support clear and predictable interactions, a single time slot is divided into multiple regions where events can be scheduled that provide for an ordering of particular types of execution. This allows properties and checkers to sample data when the design under test is in a stable state. Property expressions can be safely evaluated, and testbenches can react to both properties and checkers with zero delay, all in a predictable manner. This same mechanism also allows for nonzero delays in the design, clock propagation, and/or stimulus and response code to be mixed freely and consistently with cycle-accurate descriptions.

4.4 The stratified event scheduler

A compliant SystemVerilog simulator shall maintain some form of data structure that allows events to be dynamically scheduled, executed, and removed as the simulator advances through time. The data structure is normally implemented as a time-ordered set of linked lists, which are divided and subdivided in a well-defined manner.

The first division is by time. Every event has one and only one simulation execution time, which at any given point during simulation can be the current time or some future time. All scheduled events at a specific time define a time slot. Simulation proceeds by executing and removing all events in the current simulation time slot before moving on to the next nonempty time slot, in time order. This procedure guarantees that the simulator never goes backwards in time.

A time slot is divided into a set of ordered regions:

- a) Preponed
- b) Pre-Active
- c) Active
- d) Inactive
- e) Pre-NBA
- f) NBA
- g) Post-NBA
- h) Pre-Observed
- i) Observed
- j) Post-Observed
- k) Reactive
- l) Re-Inactive
- m) Pre-Re-NBA
- n) Re-NBA
- o) Post-Re-NBA
- p) Pre-Postponed
- q) Postponed

The purpose of dividing a time slot into these ordered regions is to provide predictable interactions between the design and testbench code.

NOTE—These regions essentially encompass the IEEE Std 1364-2005 reference model for simulation, with exactly the same level of determinism. In other words, legacy Verilog code should continue to run correctly without modification within the SystemVerilog mechanism.

4.4.1 Active region sets and reactive region sets

There are two important groupings of event regions that are used to help define the scheduling of System-Verilog activity, the active region set and the reactive region set. Events scheduled in the Active, Inactive, Pre-NBA, NBA, and Post-NBA regions are *active region set* events. Events scheduled in the Reactive, Re-Inactive, Pre- Re-NBA, Re-NBA, and Post-Re-NBA regions are *reactive region set* events.

The Active, Inactive, Pre-NBA, NBA, Post-NBA, Pre-Observed, Observed, Post- Observed, Reactive, Re-Inactive, Pre-Re-NBA, Re-NBA, Post-Re-NBA, and Pre-Postponed regions are known as the *iterative regions*.

In addition to the active region set and reactive region set, all of the event regions of each time slot can be categorized as *simulation regions* (see [4.4.2](#)) or *PLI regions* (see [4.4.3](#)).

4.4.2 Simulation regions

The simulation regions of a time slot are the Preponed, Active, Inactive, NBA, Observed, Reactive, Re-Inactive, Re-NBA and Postponed regions. The flow of execution of the event regions is specified in [Figure 4-1](#).

4.4.2.1 Preponed events region

The #1step sampling delay provides the ability to sample data immediately before entering the current time slot. #1step sampling is identical to taking the data samples in the Preponed region of the current time slot. Sampling in the Preponed region is equivalent to sampling in the previous Postponed region.

Preponed region PLI events are also scheduled in this region (see [4.4.3.1](#)).

4.4.2.2 Active events region

The Active region holds the current active region set events being evaluated and can be processed in any order.

4.4.2.3 Inactive events region

The Inactive region holds the events to be evaluated after all the Active events are processed.

If events are being executed in the active region set, an explicit #0 delay control requires the process to be suspended and an event to be scheduled into the Inactive region of the current time slot so that the process can be resumed in the next Inactive to Active iteration.

4.4.2.4 NBA events region

The NBA (nonblocking assignment update) region holds the events to be evaluated after all the Inactive events are processed.

If events are being executed in the active region set, a nonblocking assignment creates an event in the NBA region scheduled for the current or a later simulation time.

4.4.2.5 Observed events region

The Observed region is for evaluation of property expressions when they are triggered. During property evaluation, pass/fail code shall be scheduled in the Reactive region of the current time slot. PLI callbacks are not allowed in the Observed region.

4.4.2.6 Reactive events region

The Reactive region holds the current reactive region set events being evaluated and can be processed in any order.

The code specified by blocking assignments in program blocks and the code in action blocks of concurrent assertions are scheduled in the Reactive region. The Reactive region is the reactive region set dual of the Active region (see [4.4.2.2](#)).

4.4.2.7 Re-Inactive events region

The Re-Inactive region holds the events to be evaluated after all the Reactive events are processed.

If events are being executed in the reactive region set, an explicit #0 delay control requires the process to be suspended and an event to be scheduled into the Re-Inactive region of the current time slot so that the process can be resumed in the next Re-Inactive to Reactive iteration. The Re-Inactive region is the reactive region set dual of the Inactive region (see [4.4.2.3](#)).

4.4.2.8 Re-NBA events region

The Re-NBA region holds the events to be evaluated after all the Re-Inactive events are processed.

If events are being executed in the reactive region set, a nonblocking assignment creates an event in the Re-NBA update region scheduled for the current or a later simulation time. The Re-NBA region is the reactive region set dual of the NBA region (see [4.4.2.4](#)).

4.4.2.9 Postponed events region

`$monitor`, `$strobe` and other similar events are scheduled in the Postponed region.

No new value changes are allowed to happen in the current time slot once the Postponed region is reached. Within this region, it is illegal to write values to any net or variable or to schedule an event in any previous region within the current time slot.

Postponed region PLI events are also scheduled in this region (see [4.4.3.10](#)).

4.4.3 PLI regions

In addition to the simulation regions, where PLI callbacks can be scheduled, there are additional PLI-specific regions. The PLI regions of a time slot are the Preponed, Pre-Active, Pre-NBA, Post-NBA, Pre-Observed, Post-Observed, Pre-Re-NBA, Post-Re-NBA and Pre-Postponed regions. The flow of execution of the PLI regions is specified in [Figure 4-1](#).

4.4.3.1 Preponed PLI region

The Preponed region provides for a PLI callback control point that allows PLI application routines to access data at the current time slot before any net or variable has changed state. Within this region, it is illegal to write values to any net or variable or to schedule an event in any other region within the current time slot.

NOTE—The PLI currently does not schedule callbacks in the Preponed region.

4.4.3.2 Pre-Active PLI region

The Pre-Active region provides for a PLI callback control point that allows PLI application routines to read and write values and create events before events in the Active region are evaluated (see [4.5](#)).

4.4.3.3 Pre-NBA PLI region

The Pre-NBA region provides for a PLI callback control point that allows PLI application routines to read and write values and create events before the events in the NBA region are evaluated (see [4.5](#)).

4.4.3.4 Post-NBA PLI region

The Post-NBA region provides for a PLI callback control point that allows PLI application routines to read and write values and create events after the events in the NBA region are evaluated (see [4.5](#)).

4.4.3.5 Pre-Observed PLI region

The Pre-Observed region provides for a PLI callback control point that allows PLI application routines to read values after the active region set has stabilized. Within this region, it is illegal to write values to any net or variable or to schedule an event within the current time slot.

4.4.3.6 Post-Observed PLI region

The Post-Observed region provides for a PLI callback control point that allows PLI application routines to read values after properties are evaluated (in the Observed or an earlier region).

NOTE—The PLI currently does not schedule callbacks in the Post-Observed region.

4.4.3.7 Pre-Re-NBA PLI region

The Pre-Re-NBA region provides for a PLI callback control point that allows PLI application routines to read and write values and create events before the events in the Re-NBA region are evaluated (see [4.5](#)).

4.4.3.8 Post-Re-NBA PLI region

The Post-Re-NBA region provides for a PLI callback control point that allows PLI application routines to read and write values and create events after the events in the Re-NBA region are evaluated (see [4.5](#)).

4.4.3.9 Pre-Postponed PLI region

The Pre-Postponed region provides a PLI callback control point that allows PLI application routines to read and write values and create events after processing all other regions except the Postponed region.

4.4.3.10 Postponed PLI region

The Postponed region provides a PLI callback control point that allows PLI application routines to create read-only events after processing all other regions. PLI `cbReadOnlySynch` and other similar events are scheduled in the Postponed region.

The SystemVerilog flow of time slots and event regions is shown in [Figure 4-1](#).

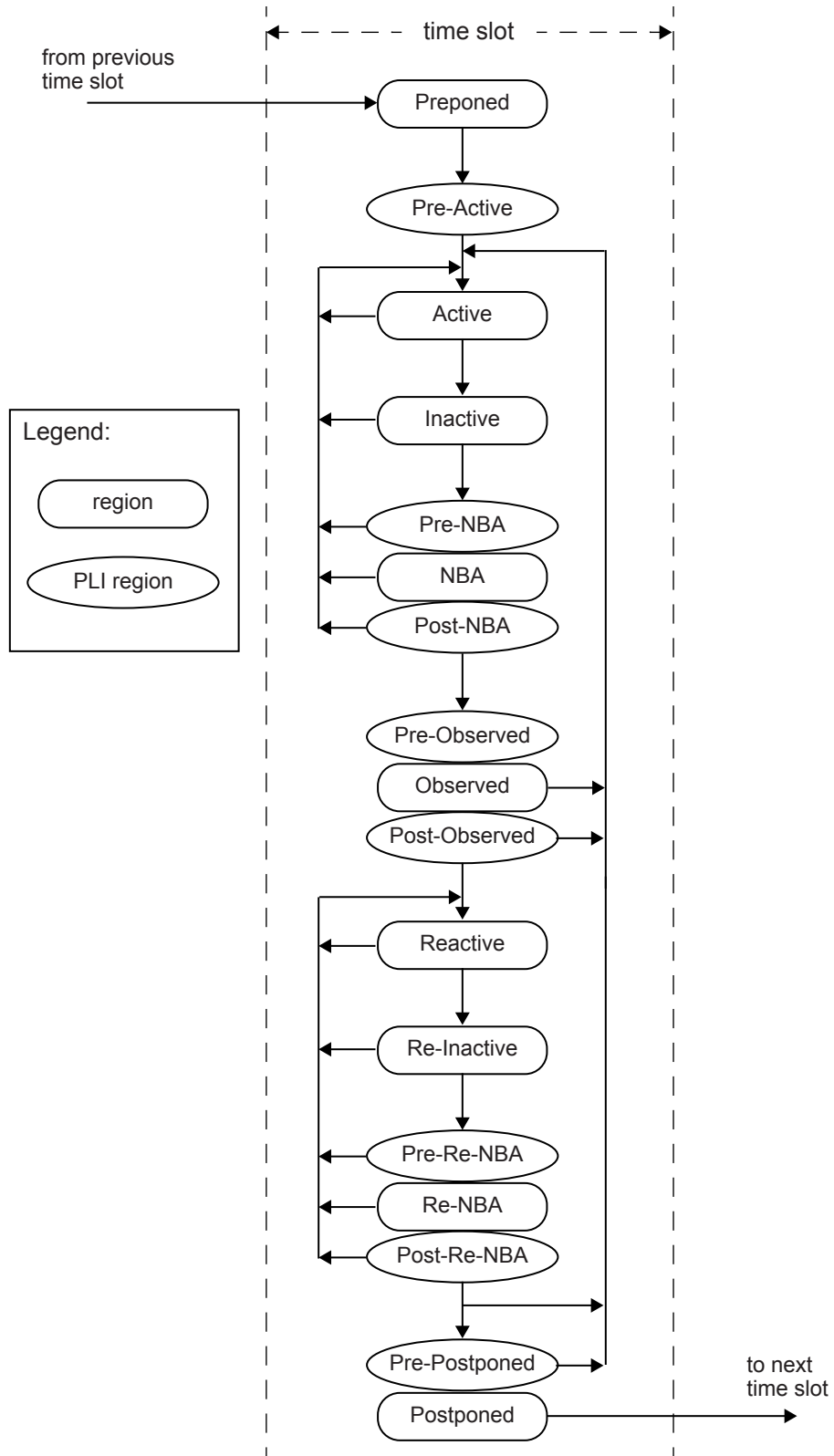

Figure 4-1—Event scheduling regions

4.5 The SystemVerilog simulation reference algorithm

```

execute_simulation {
    T = 0;
    initialize the values of all nets and variables;
    schedule all initialization events into time 0 slot;
    while (some time slot is nonempty) {
        move to the first nonempty time slot and set T;
        execute_time_slot (T);
    }
}

execute_time_slot {
    execute_region (Preponed);
    execute_region (Pre-Active);
    while (any region in [Active ... Pre-Postponed] is nonempty) {
        while (any region in [Active ... Post-Observed] is nonempty) {
            execute_region (Active);
            R = first nonempty region in [Active ... Post-Observed];
            if (R is nonempty)
                move events in R to the Active region;
        }
        while (any region in [Reactive ... Post-Re-NBA] is nonempty) {
            execute_region (Reactive);
            R = first nonempty region in [Reactive ... Post-Re-NBA];
            if (R is nonempty)
                move events in R to the Reactive region;
        }
        if (all regions in [Active ... Post-Re-NBA] are empty)
            execute_region (Pre-Postponed);
    }
    execute_region (Postponed);
}

execute_region {
    while (region is nonempty) {
        E = any event from region;
        remove E from the region;
        if (E is an update event) {
            update the modified object;
            schedule evaluation event for any process sensitive to the object;
        } else { /* E is an evaluation event */
            evaluate the process associated with the event and possibly
                schedule further events for execution;
        }
    }
}

```

The Iterative regions and their order are Active, Inactive, Pre-NBA, NBA, Post-NBA, Pre-Observed, Observed, Post-Observed, Reactive, Re-Inactive, Pre-Re-NBA, Re-NBA, Post-Re-NBA, and Pre-Postponed. As shown in the algorithm, once the Reactive, Re-Inactive Pre-Re-NBA, Re-NBA, or Post-Re-NBA regions are processed, iteration over the other regions does not resume until these five regions are empty.

4.6 Determinism

This standard guarantees a certain scheduling order:

- a) Statements within a begin-end block shall be executed in the order in which they appear in that begin-end block. Execution of statements in a particular begin-end block can be suspended in favor of other processes in the model; however, in no case shall the statements in a begin-end block be executed in any order other than that in which they appear in the source.
- b) Nonblocking assignment updates shall be performed in the order the statements were executed (see [10.4.2](#)).

Consider the following example:

```
module test;
  logic a;
  initial begin
    a <= 0;
    a <= 1;
  end
endmodule
```

When this block is executed, there will be two events added to the NBA region (nonblocking assign update region). The previous rule requires that they be entered in the event region in execution order, which, in a sequential begin-end block, is source order. This rule requires that they be taken from the NBA region and performed in execution order as well. Hence, at the end of simulation time 0, the variable `a` will be assigned 0 and then 1.

4.7 Nondeterminism

One source of nondeterminism is the fact that active events can be taken off the Active or Reactive event region and processed in any order. Another source of nondeterminism is that statements without time-control constructs in procedural blocks do not have to be executed as one event. Time control statements are the `#` expression and `@` expression constructs (see [9.4](#)). At any time while evaluating a procedural statement, the simulator may suspend execution and place the partially completed event as a pending event in the event region. The effect of this is to allow the interleaving of process execution, although the order of interleaved execution is nondeterministic and not under control of the user.

4.8 Race conditions

Because the execution of expression evaluation and net update events may be intermingled, race conditions are possible: For example:

```
assign p = q;
initial begin
  q = 1;
  #1 q = 0;
  $display(p);
end
```

The simulator is correct in displaying either a 1 or a 0. The assignment of 0 to `q` enables an update event for `p`. The simulator may either continue and execute the `$display` task or execute the update for `p`, followed by the `$display` task.

4.9 Scheduling implication of assignments

Assignments are translated into processes and events as detailed in [4.9.1](#) through [4.9.7](#).

4.9.1 Continuous assignment

A continuous assignment statement (see [10.3](#)) corresponds to a process, sensitive to the source elements in the expression. When the value of the expression changes, it causes an active update event to be added to the event region, using current values to determine the target. A continuous assignment process is also evaluated at time 0 in order to propagate constant values. This includes implicit continuous assignments inferred from port connections (see [4.9.6](#)).

4.9.2 Procedural continuous assignment

A procedural continuous assignment (which is the **assign** or **force** statement; see [10.6](#)) corresponds to a process that is sensitive to the source elements in the expression. When the value of the expression changes, it causes an active update event to be added to the event region, using current values to determine the target.

A **deassign** or a **release** statement deactivates any corresponding **assign** or **force** statement(s).

4.9.3 Blocking assignment

A blocking assignment statement (see [10.4.1](#)) with an intra-assignment delay computes the right-hand side value using the current values, then causes the executing process to be suspended and scheduled as a future event. If the delay is 0, the process is scheduled as an Inactive event for the current time. If a blocking assignment with zero delay is executed from a Reactive region, the process is scheduled as a Re-Inactive event.

When the process is returned (or if it returns immediately if no delay is specified), the process performs the assignment to the left-hand side and enables any events based upon the update of the left-hand side. The values at the time the process resumes are used to determine the target(s). Execution may then continue with the next sequential statement or with other Active or Reactive events.

4.9.4 Nonblocking assignment

A nonblocking assignment statement (see [10.4.2](#)) always computes the updated value and schedules the update as an NBA update event, either in the current time step if the delay is zero or as a future event if the delay is nonzero. The values in effect when the update is placed in the event region are used to compute both the right-hand value and the left-hand target.

4.9.5 Switch (transistor) processing

The event-driven simulation algorithm described in [4.5](#) depends on unidirectional signal flow and can process each event independently. The inputs are read, the result is computed, and the update is scheduled.

SystemVerilog provides switch-level modeling in addition to behavioral and gate-level modeling. Switches provide bidirectional signal flow and require coordinated processing of nodes connected by switches.

The source elements that model switches are various forms of transistors, called **tran**, **tranif0**, **tranif1**, **rtran**, **rtranif0**, and **rtranif1**.

Switch processing shall consider all the devices in a bidirectional switch-connected net before it can determine the appropriate value for any node on the net because the inputs and outputs interact. A simulator can do this using a relaxation technique. The simulator can process **tran** at any time. It can process a subset of **tran**-connected events at a particular time, intermingled with the execution of other active events.

Further refinement is required when some transistors have gate value x . A conceptually simple technique is to solve the network repeatedly with these transistors set to all possible combinations of fully conducting

and nonconducting transistors. Any node that has a unique logic level in all cases has steady-state response equal to this level. All other nodes have steady-state response x .

4.9.6 Port connections

Ports connect processes through implicit continuous assignment statements or implicit bidirectional connections. Bidirectional connections are analogous to an always-enabled `tran` connection between the two nets, but without any strength reduction.

Ports can always be represented as declared objects connected, as follows:

- If an input port, then a continuous assignment from an outside expression to a local (input) net or variable
- If an output port, then a continuous assignment from a local output expression to an outside net or variable
- If an inout port, then a non-strength-reducing transistor connecting the local net to an outside net

Primitive terminals, including UDP terminals, are different from module ports. Primitive output and inout terminals shall be connected directly to 1-bit nets or 1-bit structural net expressions (see [23.3.3](#)), with no intervening process that could alter the strength. Changes from primitive evaluations are scheduled as active update events in the connected nets. Input terminals connected to 1-bit nets or 1-bit structural net expressions are also connected directly, with no intervening process that could affect the strength. Input terminals connected to other kinds of expressions are represented as implicit continuous assignments from the expression to an implicit net that is connected to the input terminal.

4.9.7 Subroutines

Subroutine argument passing is by value, and it copies in on invocation and copies out on return. The copy-out-on-the-return function behaves in the same manner as does any blocking assignment.

4.10 The PLI callback control points

There are two kinds of PLI callbacks: those that are executed immediately when some specific activity occurs and those that are explicitly registered as a one-shot evaluation event.

[Table 4-1](#) provides the mapping from the various PLI callbacks.

Table 4-1—PLI callbacks

Callback	Event region
cbAfterDelay	Pre-Active
cbNextSimTime	Pre-Active
cbReadWriteSynch	Pre-NBA or Post-NBA
cbAtStartOfSimTime	Pre-Active
cbNBASynch	Pre-NBA
cbAtEndOfSimTime	Pre-postponed
cbReadOnlySynch	Postponed

5. Lexical conventions

5.1 General

This clause describes the following:

- Lexical tokens (white space, comments, operators)
- Integer, real, string, array, structure and time literals
- Built-in method calls
- Attributes

5.2 Lexical tokens

SystemVerilog source text files shall be a stream of lexical tokens. A *lexical token* shall consist of one or more characters. The layout of tokens in a source file shall be free format; that is, spaces and newlines shall not be syntactically significant other than being token separators, except for escaped identifiers (see [5.6.1](#)).

The types of lexical tokens in the language are as follows:

- White space
- Comment
- Operator
- Number
- String literal
- Identifier
- Keyword

5.3 White space

White space shall contain the characters for spaces, tabs, newlines, and formfeeds. These characters shall be ignored except when they serve to separate other lexical tokens. However, blanks and tabs shall be considered significant characters in string literals (see [5.9](#)).

5.4 Comments

SystemVerilog has two forms to introduce comments. A *one-line comment* shall start with the two characters `//` and end with a newline. A *block comment* shall start with `/*` and end with `*/`. Block comments shall not be nested. The one-line comment token `//` shall not have any special meaning in a block comment.

5.5 Operators

Operators are single-, double-, or triple-character sequences and are used in expressions. [Clause 11](#) discusses the use of operators in expressions.

Unary operators shall appear to the left of their operand. *Binary operators* shall appear between their operands. A *conditional operator* shall have two operator characters that separate three operands.

5.6 Identifiers, keywords, and system names

An *identifier* is used to give an object a unique name so it can be referenced. An identifier is either a *simple identifier* or an *escaped identifier* (see [5.6.1](#)). A *simple identifier* shall be any sequence of letters, digits, dollar signs (\$), and underscore characters (_).

The first character of a simple identifier shall not be a digit or \$; it can be a letter or an underscore. Identifiers shall be case sensitive.

For example:

```
shiftreg_a  
busa_index  
error_condition  
merge_ab  
_bus3  
n$657
```

Implementations may set a limit on the maximum length of identifiers, but the limit shall be at least 1024 characters. If an identifier exceeds the implementation-specific length limit, an error shall be reported.

5.6.1 Escaped identifiers

Escaped identifiers shall start with the backslash character (\) and end with white space (space, tab, new-line). They provide a means of including any of the printable ASCII characters in an identifier (the decimal values 33 through 126, or 21 through 7E in hexadecimal).

Neither the leading backslash character nor the terminating white space is considered to be part of the identifier. Therefore, an escaped identifier `\cpu3` is treated the same as a nonescaped identifier `cpu3`.

For example:

```
\busa+index  
\-clock  
\***error-condition***  
\net1/\net2  
\{a,b}  
\a*(b+c)
```

5.6.2 Keywords

Keywords are predefined nonescaped identifiers that are used to define the language constructs. A SystemVerilog keyword preceded by an escape character is not interpreted as a keyword.

All keywords are defined in lowercase only. [Annex B](#) gives a list of all defined keywords. Subclause [22.14](#) discusses compatibility of reserved keywords with previous versions of the IEEE 1364 and IEEE 1800 standards.

5.6.3 System tasks and system functions

The dollar sign (\$) introduces a language construct that enables development of user-defined system tasks and system functions. System constructs are not design semantics, but refer to simulator functionality. A name following the \$ is interpreted as a *system task* or a *system function*.

The syntax for system tasks and system functions is given in [Syntax 5-1](#).

```

system_tf_call ::=
    system_tf_identifier [ ( list_of_arguments ) ]
    | system_tf_identifier ( data_type [ , expression ] )
system_tf_identifier46 ::= $[ a-zA-Z0-9_$ ] { [ a-zA-Z0-9_$ ] }

```

//from [A.8.2](#)

//from [A.9.3](#)

46) The \$ character in a system_tf_identifier shall not be followed by white_space. A system_tf_identifier shall not be escaped.

Syntax 5-1—Syntax for system tasks and system functions (excerpt from [Annex A](#))

SystemVerilog defines a standard set of system tasks and system functions in this document (see [Clause 20](#) and [Clause 21](#)). Additional *user-defined system tasks* and *system functions* can be defined using the PLI, as described in [Clause 36](#). Software implementations can also specify additional system tasks and system functions, which may be tool-specific (see [Annex D](#) for some common additional system tasks and system functions). Additional system tasks and system functions are not part of this standard.

For example:

```

$display ("display a message");

$finish;

```

5.6.4 Compiler directives

The ``` character (the ASCII value 0x60, called *grave accent*) introduces a language construct used to implement compiler directives. The compiler behavior dictated by a compiler directive shall take effect as soon as the compiler reads the directive. The directive shall remain in effect for the rest of the compilation unless a different compiler directive specifies otherwise. A compiler directive in one description file can, therefore, control compilation behavior in multiple description files. The effects of a compiler directive are limited to a compilation unit (see [3.12.1](#)) and shall not affect other compilation units.

For example:

```

`define wordsize 8

```

SystemVerilog defines a standard set of compiler directives in this document (see [Clause 22](#)). Software implementations can also specify additional compiler directives, which may be tool-specific (see [Annex E](#) for some common additional compiler directives). Additional compiler directives are not part of this standard.

5.7 Numbers

Constant numbers can be specified as integer constants (see [5.7.1](#)) or real constants (see [5.7.2](#)). The formal syntax for numbers is listed in [Syntax 5-2](#).

```

primary_literal ::= number | time_literal | unbased_undefined_literal | string_literal //from A.8.4
time_literal40 ::=
    unsigned_number time_unit
    | fixed_point_number time_unit
time_unit ::= s | ms | us | ns | ps | fs
number ::= //from A.8.7
    integral_number
    | real_number
integral_number ::=
    decimal_number
    | octal_number
    | binary_number
    | hex_number
decimal_number ::=
    unsigned_number
    | [ size ] decimal_base unsigned_number
    | [ size ] decimal_base x_digit { - }
    | [ size ] decimal_base z_digit { - }
binary_number ::= [ size ] binary_base binary_value
octal_number ::= [ size ] octal_base octal_value
hex_number ::= [ size ] hex_base hex_value
sign ::= + | -
size ::= non_zero_unsigned_number
non_zero_unsigned_number29 ::= non_zero_decimal_digit { _ | decimal_digit }
real_number29 ::=
    fixed_point_number
    | unsigned_number [ . unsigned_number ] exp [ sign ] unsigned_number
fixed_point_number29 ::= unsigned_number . unsigned_number
exp ::= e | E
unsigned_number29 ::= decimal_digit { _ | decimal_digit }
binary_value29 ::= binary_digit { _ | binary_digit }
octal_value29 ::= octal_digit { _ | octal_digit }
hex_value29 ::= hex_digit { _ | hex_digit }
decimal_base29 ::= '[s]d' | '[s]D'
binary_base29 ::= '[s]b' | '[s]B'
octal_base29 ::= '[s]o' | '[s]O'
hex_base29 ::= '[s]h' | '[s]H'
non_zero_decimal_digit ::= 1 | 2 | 3 | 4 | 5 | 6 | 7 | 8 | 9
decimal_digit ::= 0 | 1 | 2 | 3 | 4 | 5 | 6 | 7 | 8 | 9
binary_digit ::= x_digit | z_digit | 0 | 1
octal_digit ::= x_digit | z_digit | 0 | 1 | 2 | 3 | 4 | 5 | 6 | 7
hex_digit ::= x_digit | z_digit | 0 | 1 | 2 | 3 | 4 | 5 | 6 | 7 | 8 | 9 | a | b | c | d | e | f | A | B | C | D | E | F
x_digit ::= x | X
z_digit ::= z | Z | ?
unbased_undefined_literal ::= '0' | '1' | 'z_or_x'44
string_literal ::= " { Any_ASCII_Characters } " //from A.8.8

```

²⁹) Embedded spaces are illegal.

⁴⁰) The unsigned number or fixed-point number in time_literal shall not be followed by a white_space.

⁴⁴) The apostrophe (') in unbased_undefined_literal shall not be followed by white_space.

5.7.1 Integer literal constants

Integer literal constants can be specified in decimal, hexadecimal, octal, or binary format.

There are two forms to express integer literal constants. The first form is a simple decimal number, which shall be specified as a sequence of digits 0 through 9, optionally starting with a plus or minus unary operator. The second form specifies a *based literal constant*, which shall be composed of up to three tokens—an optional size constant, an apostrophe character (' , ASCII 0x27) followed by a base format character, and the digits representing the value of the number. It shall be legal to macro-substitute these three tokens.

The first token, a size constant, shall specify the size of the integer literal constant in terms of its exact number of bits. It shall be specified as a nonzero unsigned decimal number. For example, the size specification for two hexadecimal digits is eight because one hexadecimal digit requires 4 bits.

The second token, a `base_format`, shall consist of a case insensitive letter specifying the base for the number, optionally preceded by the single character `s` (or `S`) to indicate a signed quantity, preceded by the apostrophe character. Legal base specifications are `d`, `D`, `h`, `H`, `o`, `O`, `b`, or `B` for the bases decimal, hexadecimal, octal, and binary, respectively.

The apostrophe character and the base format character shall not be separated by any white space.

The third token, an unsigned number, shall consist of digits that are legal for the specified base format. The unsigned number token shall immediately follow the base format, optionally preceded by white space. The hexadecimal digits `a` to `f` shall be case insensitive.

Simple decimal numbers without the size and the base format shall be treated as *signed integers*, whereas the numbers specified with the base format shall be treated as signed integers if the `s` designator is included or as *unsigned integers* if the base format only is used. The `s` designator does not affect the bit pattern specified, only its interpretation.

A plus or minus operator preceding the size constant is a unary plus or minus operator. A plus or minus operator between the base format and the number is an illegal syntax.

Negative numbers shall be represented in twos-complement form.

An `x` represents the *unknown value* in hexadecimal, octal, and binary literal constants. A `z` represents the *high-impedance value*. See [6.3](#) for a discussion of the SystemVerilog value set. An `x` shall set 4 bits to unknown in the hexadecimal base, 3 bits in the octal base, and 1 bit in the binary base. Similarly, a `z` shall set 4 bits, 3 bits, and 1 bit, respectively, to the high-impedance value.

If the size of the unsigned number is smaller than the size specified for the literal constant, the unsigned number shall be padded to the left with zeros. If the leftmost bit in the unsigned number is an `x` or a `z`, then an `x` or a `z` shall be used to pad to the left, respectively. If the size of the unsigned number is larger than the size specified for the literal constant, the unsigned number shall be truncated from the left.

The number of bits that make up an unsized number (which is a simple decimal number or a number with a base specifier but no size specification) shall be at least 32. Unsized unsigned literal constants where the high-order bit is unknown (`x` or `x`) or three-state (`z` or `z`) shall be extended to the size of the expression containing the literal constant.

NOTE—In IEEE Std 1364-1995, in unsized literal constants where the high-order bit is unknown or three-state, the `x` or `z` was only extended to 32 bits.

An unsized single-bit value can be specified by preceding the single-bit value with an apostrophe ('), but without the base specifier. All bits of the unsized value shall be set to the value of the specified bit. In a

self-determined context, an unsized single-bit value shall have a width of 1 bit, and the value shall be treated as unsigned.

```
'0, '1, 'X, 'x, 'Z, 'z // sets all bits to specified value
```

The use of `x` and `z` in defining the value of a number is case insensitive.

When used in a number, the question mark (?) character is a SystemVerilog alternative for the `z` character. It sets 4 bits to the high-impedance value in hexadecimal numbers, 3 bits in octal, and 1 bit in binary. The question mark can be used to enhance readability in cases where the high-impedance value is a do-not-care condition. See the discussion of `casez` and `casex` in [12.5.1](#). The question mark character is also used in user-defined primitive (UDP) state tables. See [Table 29-1](#) in [29.3.6](#).

In a decimal literal constant, the unsigned number token shall not contain any `x`, `z`, or `?` digits, unless there is exactly one digit in the token, indicating that every bit in the decimal literal constant is `x` or `z`.

The underscore character (`_`) shall be legal anywhere in a number except as the first character. The underscore character is ignored. This feature can be used to break up long numbers for readability purposes.

Several examples of specifying literal integer numbers are as follows:

Example 1—Unsized literal constant numbers

```
659 // is a decimal number
'h 837FF // is a hexadecimal number
'o7460 // is an octal number
4af // is illegal (hexadecimal format requires 'h)
```

Example 2—Sized literal constant numbers

```
4'b1001 // is a 4-bit binary number
5 'D 3 // is a 5-bit decimal number
3'b01x // is a 3-bit number with the least
// significant bit unknown
12'hx // is a 12-bit unknown number
16'hz // is a 16-bit high-impedance number
```

Example 3—Using sign with literal constant numbers

```
8 'd -6 // this is illegal syntax
-8 'd 6 // this defines the two's complement of 6,
// held in 8 bits—equivalent to -(8'd 6)
4 'shf // this denotes the 4-bit number '1111', to
// be interpreted as a 2's complement number,
// or '-1'. This is equivalent to -4'h 1
-4 'sd15 // this is equivalent to -(-4'd 1), or '0001'
16'sd? // the same as 16'sbz
```

Example 4—Automatic left padding of literal constant numbers

```
logic [11:0] a, b, c, d;
logic [84:0] e, f, g;
initial begin
  a = 'h x; // yields xxx
  b = 'h 3x; // yields 03x
  c = 'h z3; // yields zz3
```

```

d = 'h 0z3;    // yields 0z3

e = 'h5;       // yields {82{1'b0},3'b101}
f = 'hx;       // yields {85{1'hx}}
g = 'hz;       // yields {85{1'hz}}

end

```

Example 5—Automatic left padding of constant literal numbers using a single-bit value

```

logic [15:0] a, b, c, d;
a = '0;        // sets all 16 bits to 0
b = '1;        // sets all 16 bits to 1
c = 'x;        // sets all 16 bits to x
d = 'z;        // sets all 16 bits to z

```

Example 6—Underscores in literal constant numbers

```

27_195_000           // unsized decimal 27195000
16'b0011_0101_0001_1111 // 16-bit binary number
32 'h 12ab_f001      // 32-bit hexadecimal number

```

Sized negative literal constant numbers and sized signed literal constant numbers are sign-extended when assigned to a data object of type **logic**, regardless of whether the type itself is signed.

The default length of *x* and *z* is the same as the default length of an integer.

5.7.2 Real literal constants

The *real literal constant numbers* shall be represented as described by *IEEE Std 754*, an IEEE standard for double-precision floating-point numbers.

Real numbers can be specified in either decimal notation (for example, 14.72) or in scientific notation (for example, 39e8, which indicates 39 multiplied by 10 to the eighth power). Real numbers expressed with a decimal point shall have at least one digit on each side of the decimal point.

For example:

```

1.2
0.1
2394.26331
1.2E12 (the exponent symbol can be e or E)
1.30e-2
0.1e-0
23E10
29E-2
236.123_763_e-12 (underscores are ignored)

```

The following are invalid forms of real numbers because they do not have at least one digit on each side of the decimal point:

```

.12
9.
4.E3
.2e-7

```

The default type for fixed-point format (e.g., 1.2), and exponent format (e.g., 2.0e10) shall be **real**.

A cast can be used to convert literal real values to the **shortreal** type (e.g., **shortreal'** (1.2)). Casting is described in [6.24](#).

Real numbers shall be converted to integers by rounding the real number to the nearest integer, rather than by truncating it. Implicit conversion shall take place when a real number is assigned to an integer. The ties shall be rounded away from zero. For example:

- The real numbers 35.7 and 35.5 both become 36 when converted to an integer and 35.2 becomes 35.
- Converting -1.5 to integer yields -2 , converting 1.5 to integer yields 2.

5.8 Time literals

Time is written in integer or fixed-point format, followed without a space by a time unit (**fs ps ns us ms s**). For example:

```
2.1ns
40ps
```

The time literal is interpreted as a **realtime** value scaled to the current time unit and rounded to the current time precision.

5.9 String literals

A *string literal* is a sequence of characters enclosed by double quotes ("").

Nonprinting and other special characters are preceded with a backslash.

A string literal shall be contained in a single line unless the new line is immediately preceded by a \ (backslash). In this case, the backslash and the new line are ignored. There is no predefined limit to the length of a string literal.

Example 1:

```
$display("Humpty Dumpty sat on a wall. \
Humpty Dumpty had a great fall.");
```

prints

```
Humpty Dumpty sat on a wall. Humpty Dumpty had a great fall.
```

Example 2:

```
$display("Humpty Dumpty sat on a wall.\n\
Humpty Dumpty had a great fall.");
```

prints

```
Humpty Dumpty sat on a wall.
Humpty Dumpty had a great fall.
```

String literals used as operands in expressions and assignments shall be treated as unsigned integer constants represented by a sequence of 8-bit ASCII values, with one 8-bit ASCII value representing one character.

A string literal can be assigned to an integral type, such as a packed array. If the size differs, it is right justified. To fully store a string literal, the integral type should be declared with a width equal to the number of characters in the string multiplied by 8. For example:

```
byte c1 = "A" ;
bit [7:0] d = "\n" ;
```

The rules of SystemVerilog assignments shall be followed if the packed array width does not match the number of characters multiplied by 8. When an integral type is larger than required to hold the literal string value being assigned, the value is right-justified, and the leftmost bits are padded with zeros, as is done with nonstring values. If a string literal is larger than the destination integral type, the string is right-justified, and the leftmost characters are truncated.

For example, to store the 12-character string "Hello world\n" requires a variable 8×12 , or 96 bits wide.

```
bit [8*12:1] stringvar = "Hello world\n";
```

Alternatively, a multidimensional packed array can be used, with 8-bit subfields, as in:

```
bit [0:11] [7:0] stringvar = "Hello world\n" ;
```

A string literal can be assigned to an unpacked array of bytes. If the size differs, it is left justified.

```
byte c3 [0:12] = "hello world\n" ;
```

Packed and unpacked arrays are discussed in [7.4](#).

String literals can also be cast to a packed or unpacked array type, which shall follow the same rules as assigning a string literal to a packed or unpacked array. Casting is discussed in [6.24](#).

SystemVerilog also includes a **string** data type to which a string literal can be assigned. Variables of type **string** have arbitrary length; they are dynamically resized to hold any string. String literals are packed arrays (of a width that is a multiple of 8 bits), and they are implicitly converted to the **string** type when assigned to a **string** type or used in an expression involving **string** type operands (see [6.16](#)).

String literals stored in vectors can be manipulated using the SystemVerilog operators. The value being manipulated by the operator is the sequence of 8-bit ASCII values. See [11.10](#) for operations on string literals.

5.9.1 Special characters in strings

Certain characters can only be used in string literals when preceded by an introductory character called an *escape character*. [Table 5-1](#) lists these characters in the right-hand column, with the escape sequence that represents the character in the left-hand column.

Table 5-1—Specifying special characters in string literals

Escape string	Character produced by escape string
\n	Newline character
\t	Tab character
\\	\ character
\"	" character

Table 5-1—Specifying special characters in string literals (continued)

Escape string	Character produced by escape string
<code>\v</code>	vertical tab
<code>\f</code>	form feed
<code>\a</code>	bell
<code>\ddd</code>	A character specified in 1 to 3 octal_digits (see Syntax 5-2). If fewer than three characters are used, the following character shall not be an octal_digit. Implementations may issue an error if the character represented is greater than <code>\377</code> . It shall be illegal for an octal_digit in an escape sequence to be an x_digit or a z_digit (see Syntax 5-2).
<code>\xdd</code>	A character specified in 1 to 2 hex_digits (see Syntax 5-2). If only one digit is used, the following character shall not be a hex_digit. It shall be illegal for a hex_digit in an escape sequence to be an x_digit or a z_digit (see Syntax 5-2).

5.10 Structure literals

Structure literals are structure assignment patterns or pattern expressions with constant member expressions (see [10.9.2](#)). A structure literal must have a type, which may be either explicitly indicated with a prefix or implicitly indicated by an assignment-like context (see [10.8](#)).

```
typedef struct {int a; shortreal b;} ab;
ab c;
c = '{0, 0.0}; // structure literal type determined from
              // the left-hand context (c)
```

Nested braces shall reflect the structure. For example:

```
ab abarr[1:0] = '{{1, 1.0}, {2, 2.0}};
```

The C-like alternative `{1, 1.0, 2, 2.0}` for the preceding example is not allowed.

Structure literals can also use member name and value or use data type and default value (see [10.9.2](#)):

```
c = '{a:0, b:0.0}; // member name and value for that member
c = '{default:0}; // all elements of structure c are set to 0
d = ab'{int:1, shortreal:1.0}; // data type and default value for all
                               // members of that type
```

When an array of structures is initialized, the nested braces shall reflect the array and the structure. For example:

```
ab abarr[1:0] = '{{1, 1.0}, {2, 2.0}};
```

Replication operators can be used to set the values for the exact number of members. The inner pair of braces in a replication is removed.

```
struct {int X,Y,Z;} XYZ = '{3{1}};
typedef struct {int a,b[4];} ab_t;
int a,b,c;
ab_t v1[1:0] [2:0];
v1 = '{2{'{3{'{a, '{2{b,c}}}}}}};

/* expands to '{ '{3{ '{ a, '{2{ b, c }} } }},
```

```

        '{3{ '{ a, '{2{ b, c }} }} }
    } */

/* expands to '{ '{ '{ a, '{2{ b, c }} },
                '{ a, '{2{ b, c }} },
                '{ a, '{2{ b, c }} }
            },
        '{ '{ a, '{2{ b, c }} },
          '{ a, '{2{ b, c }} },
          '{ a, '{2{ b, c }} }
        }
    } */

/* expands to '{ '{ '{ a, '{ b, c, b, c } },
                '{ a, '{ b, c, b, c } },
                '{ a, '{ b, c, b, c } }
            },
        '{ '{ a, '{ b, c, b, c } },
          '{ a, '{ b, c, b, c } },
          '{ a, '{ b, c, b, c } }
        }
    } */

```

5.11 Array literals

Array literals are syntactically similar to C initializers, but with the replication operator (`{{}}`) allowed.

```
int n[1:2][1:3] = '{ '{0,1,2}, '{3{4}}};
```

The nesting of braces shall follow the number of dimensions, unlike in C. However, replication operators can be nested. The inner pair of braces in a replication is removed. A replication expression only operates within one dimension.

```
int n[1:2][1:6] = '{2{ '{3{4, 5}}}}; // same as
' '{4,5,4,5,4,5}, '{4,5,4,5,4,5}
```

Array literals are array assignment patterns or pattern expressions with constant member expressions (see [10.9.1](#)). An array literal must have a type, which may be either explicitly indicated with a prefix or implicitly indicated by an assignment-like context (see [10.8](#)).

```
typedef int triple [1:3];
$mydisplay(triple '{0,1,2});
```

Array literals can also use their index or type as a key and use a default key value (see [10.9.1](#)).

```
triple b = '{1:1, default:0}; // indices 2 and 3 assigned 0
```

5.12 Attributes

A mechanism is included for specifying properties about objects, statements, and groups of statements in the SystemVerilog source that can be used by various tools, including simulators, to control the operation or behavior of the tool. These properties are referred to as *attributes*. This subclause specifies the syntactic mechanism used for specifying attributes, without standardizing on any particular attributes.

The syntax for specifying an attribute is shown in [Syntax 5-3](#).

```
attribute_instance ::= (* attr_spec { , attr_spec } *) //from A.9.1  
attr_spec ::= attr_name [ = constant_expression ]  
attr_name ::= identifier
```

Syntax 5-3—Syntax for attributes (excerpt from [Annex A](#))

An attribute_instance can appear in the SystemVerilog description as a prefix attached to a declaration, a module item, a statement, or a port connection. It can appear as a suffix to an operator or a function name in an expression.

The default type of an attribute with no value is **bit**, with a value of 1. Otherwise, the attribute takes the type of the expression.

If the same attribute name is defined more than once for the same language element, the last attribute value shall be used; and a tool can issue a warning that a duplicate attribute specification has occurred.

Nesting of attribute instances is disallowed. It shall be illegal to specify the value of an attribute with a constant expression that contains an attribute instance.

Refer to [Annex A](#) for the syntax of specifying an attribute instance on specific language elements. Several examples are illustrated below.

Example 1—The following example shows how to attach attributes to a case statement:

```
(* full_case, parallel_case *)  
case (a)  
<rest_of_case_statement>
```

or

```
(* full_case=1 *)  
(* parallel_case=1 *) // Multiple attribute instances also OK  
case (a)  
<rest_of_case_statement>
```

or

```
(* full_case, // no value assigned  
parallel_case=1 *)  
case (a)  
<rest_of_case_statement>
```

Example 2—To attach the full_case attribute, but not the parallel_case attribute:

```
(* full_case *) // parallel_case not specified  
case (a)  
<rest_of_case_statement>
```

or

```
(* full_case=1, parallel_case = 0 *)  
case (a)  
<rest_of_case_statement>
```

Example 3—To attach an attribute to a module definition:

```
(* optimize_power *)
module mod1 (<port_list>);
```

or

```
(* optimize_power=1 *)
module mod1 (<port_list>);
```

Example 4—To attach an attribute to a module instantiation:

```
(* optimize_power=0 *)
mod1 synth1 (<port_list>);
```

Example 5—To attach an attribute to a variable declaration:

```
(* fsm_state *) logic [7:0] state1;
(* fsm_state=1 *) logic [3:0] state2, state3;
logic [3:0] reg1; // reg1 does NOT have fsm_state set
(* fsm_state=0 *) logic [3:0] reg2; // nor does reg2
```

Example 6—To attach an attribute to an operator:

```
a = b + (* mode = "cla" *) c; // sets the value for the attribute mode
// to be the string cla.
```

Example 7—To attach an attribute to a function call:

```
a = add (* mode = "cla" *) (b, c);
```

Example 8—To attach an attribute to a conditional operator:

```
a = b ? (* no_glitch *) c : d;
```

5.13 Built-in methods

SystemVerilog uses a C++ -like class method calling syntax, in which a subroutine is called using the dot notation (.):

```
object.task_or_function()
```

The object uniquely identifies the data on which the subroutine operates. Hence, the method concept is naturally extended to built-in types in order to add functionality, which traditionally was done via system tasks or system functions. Unlike system tasks, built-in methods are not prefixed with a \$ because they require no special prefix to avoid collisions with user-defined identifiers. Thus, the method syntax allows extending the language without the addition of new keywords or the cluttering of the global name space with system tasks.

Built-in methods, unlike system tasks, cannot be redefined by users via PLI tasks. Thus, only functions that users should not be allowed to redefine are good candidates for built-in method calls.

In general, a built-in method is preferred over a system task when a particular functionality applies to all data types or when it applies to a specific data type. For example:

```
dynamic_array.size, associative_array.num, and string.len
```

These are all similar concepts, but they represent different things. A dynamic array has a size, an associative array contains a given number of items, and a string has a given length. Using the same system task, such as `$size`, for all of them would be less clear and intuitive.

A built-in method can only be associated with a particular data type. Therefore, if some functionality is a simple side effect (i.e., `$stop` or `$reset`) or it operates on no specific data (i.e., `$random`), then a system task must be used.

When a subroutine built-in method call specifies no arguments, the empty parenthesis, `()`, following the subroutine name is optional. This is also true for subroutines that require arguments, when all arguments have defaults specified. For a method, this rule allows simple calls to appear as properties of the object or built-in type. Similar rules are defined for subroutines in [13.5.5](#).

6. Data types

6.1 General

This clause describes the following:

- The SystemVerilog logic value and strength set
- Net declarations
- Singular variable declarations
- Constants
- Scope and lifetime of data
- Type compatibility
- Type operator and type casting

6.2 Data types and data objects

SystemVerilog makes a distinction between an object and its data type. A data type is a set of values and a set of operations that can be performed on those values. Data types can be used to declare data objects or to define user-defined data types that are constructed from other data types. A data object is a named entity that has a data value and a data type associated with it, such as a parameter, a variable, or a net.

6.3 Value set

6.3.1 Logic values

The SystemVerilog value set consists of the following four basic values:

- 0—represents a logic zero, or a false condition
- 1—represents a logic one, or a true condition
- x—represents an unknown logic value
- z—represents a high-impedance state

The values 0 and 1 are logical complements of one another.

When the z value is present at the input of a gate or when it is encountered in an expression, the effect is usually the same as an x value. Notable exceptions are the metal-oxide semiconductor (MOS) primitives, which can pass the z value.

The name of this primitive data type is **logic**. This name can be used to declare objects and to construct other data types from the 4-state data type.

Several SystemVerilog data types are 4-state types, which can store all four logic values. All bits of 4-state vectors can be independently set to one of the four basic values. Some SystemVerilog data types are 2-state, and only store 0 or 1 values in each bit of a vector. Other exceptions are the event type (see [6.17](#)), which has no storage, and the real types (see [6.12](#)).

6.3.2 Strengths

The language includes *strength* information in addition to the basic value information for nets. This is described in detail in [Clause 28](#). The additional strength information associated with bits of a net is not considered part of the data type.

Two types of *strengths* can be specified in a net declaration, as follows:

- *Charge strength* shall only be used when declaring a net of type **trireg**.
- *Drive strength* shall only be used when placing a continuous assignment on a net in the same statement that declares the net.

Gate declarations can also specify a drive strength. See [Clause 28](#) for more information on gates and for information on strengths.

6.3.2.1 Charge strength

The charge strength specification shall be used only with **trireg** nets. A **trireg** net shall be used to model charge storage; charge strength shall specify the relative size of the capacitance indicated by one of the following keywords:

- **small**
- **medium**
- **large**

The default charge strength of a **trireg** net shall be **medium**.

A **trireg** net can model a charge storage node whose charge decays over time. The simulation time of a charge decay shall be specified in the delay specification for the **trireg** net (see [28.16.2](#)).

For example:

```
trireg a; // trireg net of charge strength medium
trireg (large) #(0,0,50) cap1; // trireg net of charge strength large
// with charge decay time 50 time units
trireg (small) signed [3:0] cap2; // signed 4-bit trireg vector of
// charge strength small
```

6.3.2.2 Drive strength

The drive strength specification allows a continuous assignment to be placed on a net in the same statement that declares that net. See [Clause 10](#) for more details. Net drive strength properties are described in detail in [Clause 28](#).

6.4 Singular and aggregate types

Data types are categorized as either *singular* or *aggregate*. A singular type shall be any data type except an unpacked structure, unpacked union, or unpacked array (see [7.4](#) on arrays). An aggregate type shall be any unpacked structure, unpacked union, or unpacked array data type. A singular variable or expression represents a single value, symbol, or handle. Aggregate expressions and variables represent a set or collection of singular values. Integral types (see [6.11.1](#)) are always singular even though they can be sliced into multiple singular values. The **string** data type is singular even though a string can be indexed in a similar way to an unpacked array of bytes.

These categories are defined so that operators and functions can simply refer to these data types as a collective group. For example, some functions recursively descend into an aggregate variable until reaching a singular value and then perform an operation on each singular value.

Although a class is a type, there are no variables or expressions of class type directly, only class object handles that are singular. Therefore, classes need not be categorized in this manner (see [Clause 8](#) on classes).

6.5 Nets and variables

There are two main groups of data objects: variables and nets. These two groups differ in the way in which they are assigned and hold values.

A net can be written by one or more continuous assignments, by primitive outputs, or through module ports. The resultant value of multiple drivers is determined by the resolution function of the net type. A net cannot be procedurally assigned. If a net on one side of a port is driven by a variable on the other side, a continuous assignment is implied. A **force** statement can override the value of a net. When released, the net returns to the resolved value.

Variables can be written by one or more procedural statements, including procedural continuous assignments. The last write determines the value. Alternatively, variables can be written by one continuous assignment or one port.

Variables can be packed or unpacked aggregates of other types (see [7.4](#) for packed and unpacked types). Multiple assignments made to independent elements of a variable are examined individually. Independent elements include different members of a structure, or different elements of an array. Each bit in a packed type is also an independent element. Thus, in an aggregate of packed types, each bit in the aggregate is an independent element.

An assignment where the left-hand side contains a slice is treated as a single assignment to the entire slice. Thus, a structure or array can have one element assigned procedurally and another element assigned continuously. And, elements of a structure or array can be assigned with multiple continuous assignments, provided that each element is covered by no more than a single continuous assignment.

The precise rule is that it shall be an error to have multiple continuous assignments or a mixture of procedural and continuous assignments writing to any term in the expansion of a written longest static prefix of a variable (see [11.5.3](#) for the definition of a longest static prefix).

For example, assume the following structure declaration:

```
struct {
    bit [7:0] A;
    bit [7:0] B;
    byte C;
} abc;
```

The following statements are legal assignments to **struct** abc:

```
assign abc.C = sel ? 8'hBE : 8'hEF;

not    (abc.A[0], abc.B[0]),
      (abc.A[1], abc.B[1]),
      (abc.A[2], abc.B[2]),
      (abc.A[3], abc.B[3]);

always @(posedge clk) abc.B <= abc.B + 1;
```

The following additional statements are illegal assignments to **struct** abc:

```
// Multiple continuous assignments to abc.C
assign abc.C = sel ? 8'hDE : 8'hED;

// Mixing continuous and procedural assignments to abc.A[3]
```



```
always @(posedge clk) abc.A[7:3] <= !abc.B[7:3];
```

For the purposes of the preceding rule, a declared variable initialization or a procedural continuous assignment is considered a procedural assignment. The **force** statement overrides the procedural assignment statement, which in turn overrides the normal assignments. A **force** statement is neither a continuous nor a procedural assignment.

A continuous assignment shall be implied when a variable is connected to an input port declaration. This makes assignments to a variable declared as an input port illegal. A continuous assignment shall be implied when a variable is connected to the output port of an instance. This makes additional procedural or continuous assignments to a variable connected to the output port of an instance illegal.

Variables cannot be connected to either side of an **inout** port. Variables can be shared across ports with the **ref** port type. See [23.3.3](#) for more information about ports and port connection rules.

The compiler can issue a warning if a continuous assignment could drive strengths other than **st0**, **st1**, **stX**, or **hiZ** to a variable. In any case, automatic type conversion shall be applied to the assignment, and the strength is lost.

Unlike nets, a variable cannot have an implicit continuous assignment as part of its declaration. An assignment as part of the declaration of a variable is a variable initialization, not a continuous assignment. For example:

```
wire w = vara & varb;           // net with a continuous assignment

logic v = consta & constb;     // variable with initialization

logic vw;                      // no initial assignment
assign vw = vara & varb;       // continuous assignment to a variable

real circ;
assign circ = 2.0 * PI * R;     // continuous assignment to a variable
```

Data shall be declared before they are used, apart from implicit nets (see [6.10](#)).

Within a name space (see [3.13](#)), it shall be illegal to redeclare a name already declared by a net, variable, or other declaration.

6.6 Net types

The *net* types can represent physical connections between structural entities, such as gates. A net shall not store a value (except for the **triereg** net). Instead, its value shall be determined by the values of its drivers, such as a continuous assignment or a gate. See [Clause 10](#) and [Clause 28](#) for definitions of these constructs. If no driver is connected to a net, its value shall be high-impedance (*z*) unless the net is a **triereg**, in which case it shall hold the previously driven value.

There are several distinct types of nets, as shown in [Table 6-1](#).

Table 6-1—Net types

wire	tri	tri0	supply0
wand	triand	tri1	supply1
wor	trior	triereg	uwire

6.6.1 Wire and tri nets

The *wire* and *tri* nets connect elements. The net types **wire** and **tri** shall be identical in their syntax and functions; two names are provided so that the name of a net can indicate the purpose of the net in that model. A **wire** net can be used for nets that are driven by a single gate or continuous assignment. The **tri** net type can be used where multiple drivers drive a net.

Logical conflicts from multiple sources of the same strength on a **wire** or a **tri** net result in x (unknown) values.

[Table 6-2](#) is a truth table for resolving multiple drivers on **wire** and **tri** nets. It assumes equal strengths for both drivers. See [28.11](#) for a discussion of logic strength modeling.

Table 6-2—Truth table for wire and tri nets

wire/tri	0	1	x	z
0	0	x	x	0
1	x	1	x	1
x	x	x	x	x
z	0	1	x	z

6.6.2 Unresolved nets

The **uwire** net is an unresolved or unidriver wire and is used to model nets that allow only a single driver. The **uwire** type can be used to enforce this restriction. It shall be an error to connect any bit of a **uwire** net to more than one driver. It shall be an error to connect a **uwire** net to a bidirectional terminal of a bidirectional pass switch.

The port connection rule in [23.3.3.6](#) enforces this restriction across the net hierarchy or shall issue a warning if not.

6.6.3 Wired nets

Wired nets are of type **wor**, **wand**, **trior**, and **triand** and are used to model wired logic configurations. Wired nets use different truth tables to resolve the conflicts that result when multiple drivers drive the same net. The **wor** and **trior** nets shall create *wired or* configurations so that when any of the drivers is 1, the resulting value of the net is 1. The **wand** and **triand** nets shall create *wired and* configurations so that if any driver is 0, the value of the net is 0.

The net types **wor** and **trior** shall be identical in their syntax and functionality. The net types **wand** and **triand** shall be identical in their syntax and functionality. [Table 6-3](#) and [Table 6-4](#) give the truth tables for wired nets, assuming equal strengths for both drivers. See [28.11](#) for a discussion of logic strength modeling.

Table 6-3—Truth table for wand and triand nets

wand/triand	0	1	x	z
0	0	0	0	0
1	0	1	x	1
x	0	x	x	x
z	0	1	x	z

Table 6-4—Truth table for wor and trior nets

wor/trior	0	1	x	z
0	0	1	x	0
1	1	1	1	1
x	x	1	x	x
z	0	1	x	z

6.6.4 Trireg net

The *trireg* net stores a value and is used to model charge storage nodes. A *trireg* net can be in one of two states, as follows:

- Driven state* When at least one driver of a **trireg** net has a value of 1, 0, or x, the resolved value propagates into the **trireg** net and is the driven value of the **trireg** net.
- Capacitive state* When all the drivers of a **trireg** net are at the high-impedance value (z), the **trireg** net retains its last driven value; the high-impedance value does not propagate from the driver to the **trireg**.

The strength of the value on the **trireg** net in the capacitive state can be **small**, **medium**, or **large**, depending on the size specified in the declaration of the **trireg** net. The strength of a **trireg** net in the driven state can be **supply**, **strong**, **pull**, or **weak**, depending on the strength of the driver.

For example, [Figure 6-1](#) shows a schematic that includes a **trireg** net whose size is **medium**, its driver, and the simulation results.

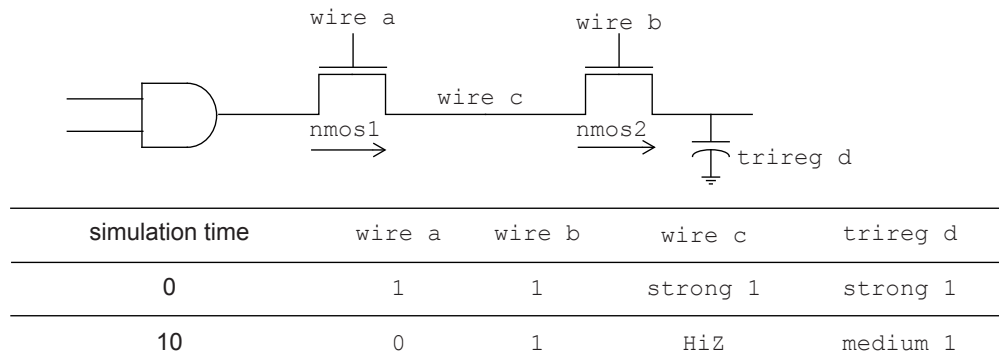

Figure 6-1—Simulation values of a trireg and its driver

- a) At simulation time 0, wire a and wire b have a value of 1. A value of 1 with a **strong** strength propagates from the **and** gate through the **nmos** switches connected to each other by wire c into trireg net d.
- b) At simulation time 10, wire a changes value to 0, disconnecting wire c from the **and** gate. When wire c is no longer connected to the **and** gate, the value of wire c changes to HiZ. The value of wire b remains 1 so wire c remains connected to trireg net d through the **nmos2** switch. The HiZ value does not propagate from wire c into trireg net d. Instead, **trireg** net d enters the capacitive state, storing its last driven value of 1. It stores the 1 with a **medium** strength.

6.6.4.1 Capacitive networks

A capacitive network is a connection between two or more trireg nets. In a capacitive network whose trireg nets are in the capacitive state, logic and strength values can propagate between trireg nets.

For example, [Figure 6-2](#) shows a capacitive network in which the logic value of some trireg nets change the logic value of other trireg nets of equal or smaller size.

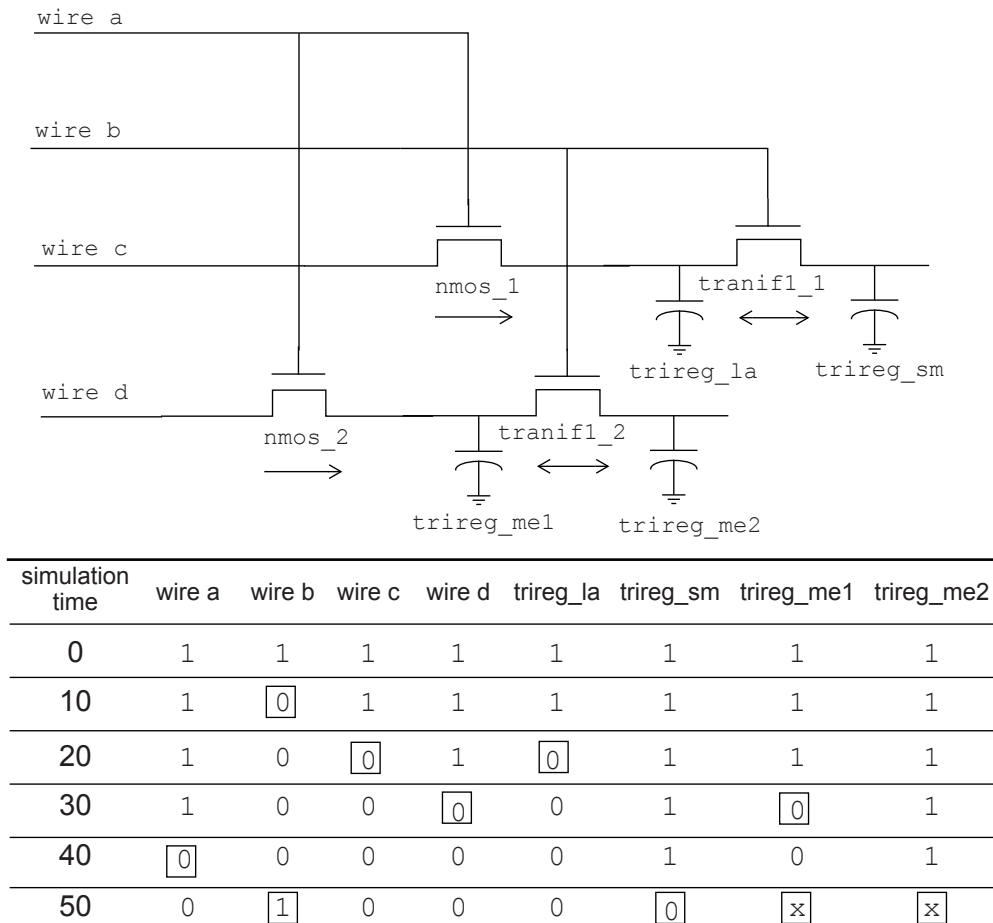

Figure 6-2—Simulation results of a capacitive network

In [Figure 6-2](#), the capacitive strength of `trireg_la` net is **large**, `trireg_me1` and `trireg_me2` are **medium**, and `trireg_sm` is **small**. Simulation reports the following sequence of events:

- At simulation time 0, wire a and wire b have a value of 1. The wire c drives a value of 1 into `trireg_la` and `trireg_sm`; wire d drives a value of 1 into `trireg_me1` and `trireg_me2`.
- At simulation time 10, the value of wire b changes to 0, disconnecting `trireg_sm` and `trireg_me2` from their drivers. These `trireg` nets enter the capacitive state and store the value 1, their last driven value.
- At simulation time 20, wire c drives a value of 0 into `trireg_la`.
- At simulation time 30, wire d drives a value of 0 into `trireg_me1`.
- At simulation time 40, the value of wire a changes to 0, disconnecting `trireg_la` and `trireg_me1` from their drivers. These `trireg` nets enter the capacitive state and store the value 0.
- At simulation time 50, the value of wire b changes to 1.
- This change of value in wire b connects `trireg_sm` to `trireg_la`; these `trireg` nets have different sizes and stored different values. This connection causes the smaller `trireg` net to store the value of the larger `trireg` net, and `trireg_sm` now stores a value of 0.

This change of value in wire b also connects `trireg_me1` to `trireg_me2`; these `trireg` nets have the same size and stored different values. The connection causes both `trireg_me1` and `trireg_me2` to change value to x.

In a capacitive network, charge strengths propagate from a larger trireg net to a smaller trireg net. [Figure 6-3](#) shows a capacitive network and its simulation results.

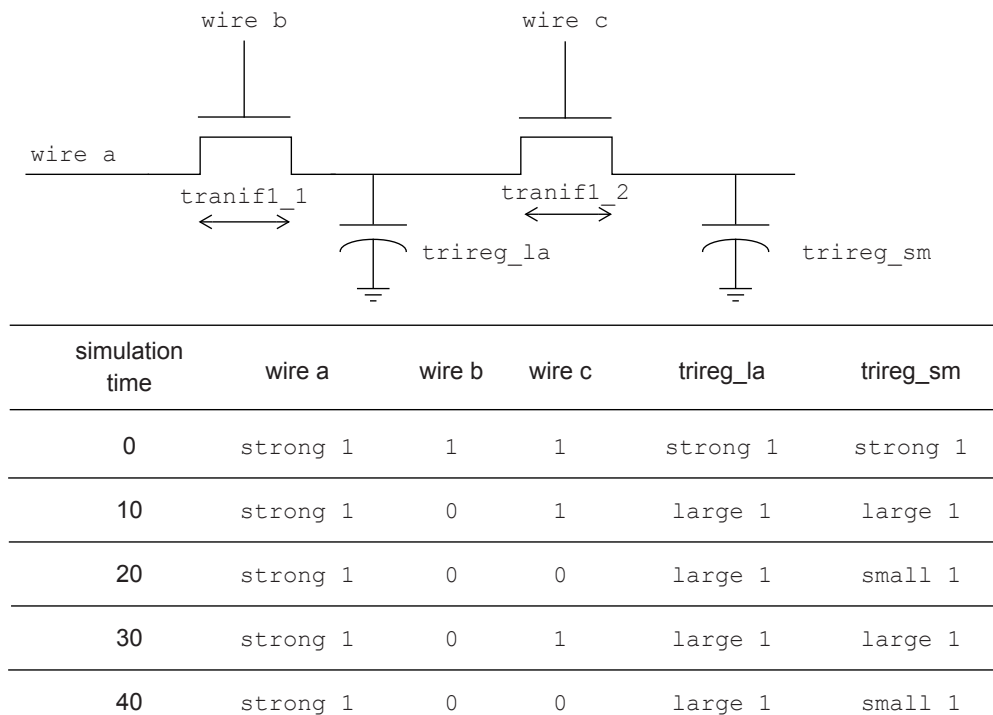

Figure 6-3—Simulation results of charge sharing

In [Figure 6-3](#), the capacitive strength of `trireg_la` is **large**, and the capacitive strength of `trireg_sm` is **small**. Simulation reports the following results:

- At simulation time 0, the values of wire a, wire b, and wire c are 1, and wire a drives a **strong 1** into `trireg_la` and `trireg_sm`.
- At simulation time 10, the value of wire b changes to 0, disconnecting `trireg_la` and `trireg_sm` from wire a. The `trireg_la` and `trireg_sm` nets enter the capacitive state. Both trireg nets share the **large** charge of `trireg_la` because they remain connected through `tranifl_2`.
- At simulation time 20, the value of wire c changes to 0, disconnecting `trireg_sm` from `trireg_la`. The `trireg_sm` no longer shares **large** charge of `trireg_la` and now stores a **small** charge.
- At simulation time 30, the value of wire c changes to 1, connecting the two trireg nets. These trireg nets now share the same charge.
- At simulation time 40, the value of wire c changes again to 0, disconnecting `trireg_sm` from `trireg_la`. Once again, `trireg_sm` no longer shares the **large** charge of `trireg_la` and now stores a **small** charge.

6.6.4.2 Ideal capacitive state and charge decay

A `trireg` net can retain its value indefinitely, or its charge can decay over time. The simulation time of charge decay is specified in the delay specification of the `trireg` net. See [28.16.2](#) for charge decay explanation.

6.6.5 Tri0 and tri1 nets

The `tri0` and `tri1` nets model nets with resistive *pulldown* and resistive *pullup* devices on them. A `tri0` net is equivalent to a wire net with a continuous 0 value of `pull` strength driving it. A `tri1` net is equivalent to a wire net with a continuous 1 value of `pull` strength driving it.

When no driver drives a `tri0` net, its value is 0 with strength `pull`. When no driver drives a `tri1` net, its value is 1 with strength `pull`. When there are drivers on a `tri0` or `tri1` net, the drivers combine with the strength `pull` value implicitly driven on the net to determine the net's value. See [28.11](#) for a discussion of logic strength modeling.

[Table 6-5](#) and [Table 6-6](#) are truth tables for modeling multiple drivers of strength `strong` on `tri0` and `tri1` nets. The resulting value on the net has strength `strong`, unless both drivers are `z`, in which case the net has strength `pull`.

Table 6-5—Truth table for tri0 net

<code>tri0</code>	0	1	x	z
0	0	x	x	0
1	x	1	x	1
x	x	x	x	x
z	0	1	x	0

Table 6-6—Truth table for tri1 net

<code>tri1</code>	0	1	x	z
0	0	x	x	0
1	x	1	x	1
x	x	x	x	x
z	0	1	x	1

6.6.6 Supply nets

The `supply0` and `supply1` nets can be used to model the power supplies in a circuit. These nets shall have `supply` strengths.

6.7 Net declarations

The syntax for net declarations is given in [Syntax 6-1](#).

```

net_declaration11 ::=
    net_type [ drive_strength | charge_strength ] [ vectored | scalared ]
    data_type_or_implicit [ delay3 ] list_of_net_decl_assignments ;
    
```

// from [A.2.1.3](#)

```

net_type ::= // from A.2.2.1
    supply0 | supply1 | tri | triand | trior | trireg | tri0 | tri1 | uwire | wire | wand | wor
drive_strength ::= // from A.2.2.2
    ( strength0 , strength1 )
    | ( strength1 , strength0 )
    | ( strength0 , highz1 )
    | ( strength1 , highz0 )
    | ( highz0 , strength1 )
    | ( highz1 , strength0 )
strength0 ::= supply0 | strong0 | pull0 | weak0
strength1 ::= supply1 | strong1 | pull1 | weak1
charge_strength ::= ( small ) | ( medium ) | ( large )
delay3 ::= // from A.2.2.3
    # delay_value | # ( mintypmax_expression [ , mintypmax_expression [ , mintypmax_expression ] ] )
delay2 ::= # delay_value | # ( mintypmax_expression [ , mintypmax_expression ] )
delay_value ::=
    unsigned_number
    | real_number
    | ps_identifier
    | time_literal
    | 1step
list_of_net_decl_assignments ::= net_decl_assignment { , net_decl_assignment } // from A.2.3
net_decl_assignment ::= net_identifier { unpacked_dimension } [ = expression ] // from A.2.4

```

11) A charge strength shall only be used with the **trireg** keyword. When the **vectored** or **scalared** keyword is used, there shall be at least one packed dimension.

Syntax 6-1—Syntax for net declarations (excerpt from [Annex A](#))

Net declarations without assignments are described in this clause. Net declarations with assignments are described in [Clause 10](#).

A net declaration begins with a net type that determines how the values of the nets in the declaration are resolved. The declaration can include optional information such as delay values, drive or charge strength, and a data type.

If a set of nets share the same characteristics, they can be declared in the same declaration statement.

Any 4-state data type can be used to declare a net. For example:

```

trireg (large) logic #(0,0,0) cap1;
typedef logic [31:0] addressT;
wire addressT w1;
wire struct packed { logic ecc; logic [7:0] data; } memsig;

```

If a data type is not specified in the net declaration or if only a range and/or signing is specified, then the data type of the net is implicitly declared as **logic**. For example:

```

wire w;           // equivalent to "wire logic w;"
wire [15:0] ww;   // equivalent to "wire logic [15:0] ww;"

```

Certain restrictions apply to the data type of a net. A valid data type for a net shall be one of the following:

- a) A 4-state integral type, including a packed array or packed structure.
- b) A fixed-size unpacked array or unpacked structure, where each element has a valid data type for a net.

The effect of this recursive definition is that a net is composed entirely of 4-state bits and is treated accordingly. In addition to a signal value, each bit of a net shall have additional strength information. When bits of signals combine, the strength and value of the resulting signal shall be determined as described in [28.12](#).

A lexical restriction applies to the use of the `reg` keyword in a net or port declaration. A net type keyword shall not be followed directly by the `reg` keyword. Thus, the following declarations are in error:

```
tri reg r;
inout wire reg p;
```

The `reg` keyword can be used in a net or port declaration if there are lexical elements between the net type keyword and the `reg` keyword.

The default initialization value for a net shall be the value z. Nets with drivers shall assume the output value of their drivers. The `triereg` net is an exception. The `triereg` net shall default to the value x, with the strength specified in the net declaration (`small`, `medium`, or `large`).

6.8 Variable declarations

A *variable* is an abstraction of a data storage element. A variable shall store a value from one assignment to the next. An assignment statement in a procedure acts as a trigger that changes the value in the data storage element.

The syntax for variable declarations is given in [Syntax 6-2](#)

```
data_declaration9 ::= // from A.2.1.3
  [ const ] [ var ] [ lifetime ] data_type_or_implicit list_of_variable_decl_assignments ;
  | type_declaration
  ...
data_type ::= // from A.2.2.1
  integer_vector_type [ signing ] { packed_dimension }
  | integer_atom_type [ signing ]
  | non_integer_type
  | struct_union [ packed [ signing ] ] { struct_union_member { struct_union_member } }
    { packed_dimension }12
  | enum [ enum_base_type ] { enum_name_declaration { , enum_name_declaration } }
    { packed_dimension }
  | string
  | chandle
  | virtual [ interface ] interface_identifier
  | [ class_scope | package_scope ] type_identifier { packed_dimension }
  | class_type
  | event
  | ps_covergroup_identifier
  | type_reference13
integer_type ::= integer_vector_type | integer_atom_type
integer_atom_type ::= byte | shortint | int | longint | integer | time
```

```

integer_vector_type ::= bit | logic | reg
non_integer_type ::= shortreal | real | realtime
signing ::= signed | unsigned
simple_type ::= integer_type | non_integer_type | ps_type_identifier
data_type_or_void ::= data_type | void
variable_decl_assignment ::= //from A.2.4
    variable_identifier { variable_dimension } [ = expression ]
    | dynamic_array_variable_identifier unsized_dimension { variable_dimension }
      [ = dynamic_array_new ]
    | class_variable_identifier [ = class_new ]

```

- 9) In a data_declaration that is not within a procedural context, it shall be illegal to use the **automatic** keyword. In a data_declaration, it shall be illegal to omit the explicit data_type before a list_of_variable_decl_assignments unless the **var** keyword is used.
- 12) When a packed dimension is used with the **struct** or **union** keyword, the **packed** keyword shall also be used.
- 13) When a type_reference is used in a net declaration, it shall be preceded by a net type keyword; and when it is used in a variable declaration, it shall be preceded by the **var** keyword.

Syntax 6-2—Syntax for variable declarations (excerpt from [Annex A](#))

One form of variable declaration consists of a data type followed by one or more instances.

```
shortint s1, s2[0:9];
```

Another form of variable declaration begins with the keyword **var**. The data type is optional in this case. If a data type is not specified or if only a range and/or signing is specified, then the data type is implicitly declared as **logic**.

```

var byte my_byte;    // equivalent to "byte my_byte;"
var v;              // equivalent to "var logic v;"
var [15:0] vw;      // equivalent to "var logic [15:0] vw;"
var enum bit { clear, error } status;
input var logic data_in;
var reg r;

```

If a set of variables share the same characteristics, they can be declared in the same declaration statement.

A variable can be declared with an initializer, for example:

```
int i = 0;
```

Setting the initial value of a static variable as part of the variable declaration (including static class members) shall occur before any initial or always procedures are started (also see [6.21](#) and [10.5](#) on variable initialization with static and automatic lifetimes).

NOTE—In IEEE Std 1364-2005, an initialization value specified as part of the declaration was executed as if the assignment were made from an initial procedure, after simulation has started.

Initial values are not constrained to simple constants; they can include run-time expressions, including dynamic memory allocation. For example, a static class handle or a mailbox can be created and initialized by calling its new method (see [15.4.1](#)), or static variables can be initialized to random values by calling the \$urandom system task. This may require a special pre-initial pass at run time.

[Table 6-7](#) contains the default values for variables if no initializer is specified.

Table 6-7—Default values

Type	Default initial value
4-state integral	'X
2-state integral	'0
real , shortreal	0.0
enumeration	base type default initial value
string	"" (empty string)
event	new event
class	null
chandle (Opaque handle)	null

Nets and variables can be assigned negative values, but only signed types shall retain the significance of the sign. The **byte**, **shortint**, **int**, **integer**, and **longint** types are signed types by default. Other net and variable types can be explicitly declared as signed. See [11.4.3.1](#) for a description of how signed and unsigned nets and variables are treated by certain operators.

6.9 Vector declarations

A data object declared as **reg**, **logic**, or **bit** (or as a matching user-defined type or implicitly as **logic**) without a range specification shall be considered 1 bit wide and is known as a *scalar*. A multibit data object of one of these types shall be declared by specifying a range, and is known as a *vector*. Vectors are packed arrays of scalars (see [7.4](#)).

6.9.1 Specifying vectors

The range specification gives addresses to the individual bits in a multibit **reg**, **logic**, or **bit** vector. The most significant bit specified by the *msb* constant expression is the left-hand value in the range, and the least significant bit specified by the *lsb* constant expression is the right-hand value in the range.

Both the *msb* constant expression and the *lsb* constant expression shall be constant integer expressions. The *msb* and *lsb* constant expressions (see [11.2.1](#)) may be any integer value—positive, negative, or zero. It shall be illegal for them to contain any unknown (x) or high-impedance bits. The *lsb* value may be greater than, equal to, or less than the *msb* value.

Vectors shall obey laws of arithmetic modulo-2 to the power n (2^n), where n is the number of bits in the vector. Vectors of **reg**, **logic**, and **bit** types shall be treated as unsigned quantities, unless declared to be signed or connected to a port that is declared to be signed (see [23.2.2.1](#) and [23.3.3.8](#)).

Examples:

```

wand w;                // a scalar "wand" net
tri [15:0] busa;       // a 16-bit bus
trireg (small) storeit; // a charge storage node of strength small
logic a;               // a scalar variable
logic[3:0] v;          // a 4-bit vector made up of (from most to
                        // least significant)v[3], v[2], v[1], and v[0]

```

```

logic signed [3:0] signed_reg; // a 4-bit vector in range -8 to 7
logic [-1:4] b; // a 6-bit vector
wire w1, w2; // declares two nets
logic [4:0] x, y, z; // declares three 5-bit variables

```

Implementations may set a limit on the maximum length of a vector, but the limit shall be at least 65536 (2^{16}) bits.

Implementations are not required to detect overflow of integer operations.

6.9.2 Vector net accessibility

Vectored and *scalared* shall be optional advisory keywords to be used in vector net declarations. If these keywords are implemented, certain operations on vector nets may be restricted. If the keyword **vectored** is used, bit-selects and part-selects and strength specifications may not be permitted, and the PLI may consider the net *unexpanded*. If the keyword **scalared** is used, bit-selects and part-selects of the net shall be permitted, and the PLI shall consider the net *expanded*.

For example:

```

tri1 scalared [63:0] bus64; //a bus that will be expanded
tri vectored [31:0] data; //a bus that may or may not be expanded

```

6.10 Implicit declarations

The syntax shown in [6.7](#) and [6.8](#) shall be used to declare nets and variables explicitly. In the absence of an explicit declaration, an implicit net of default net type shall be assumed in the following circumstances:

- If an identifier is used in a port expression declaration, then an implicit net of default net type shall be assumed, with the vector width of the port expression declaration. See [23.2.2.1](#) for a discussion of port expression declarations.
- If an identifier is used in the terminal list of a primitive instance or a module instance, and that identifier has not been declared previously in the scope where the instantiation appears or in any scope whose declarations can be directly referenced from the scope where the instantiation appears (see [23.9](#)), then an implicit scalar net of default net type shall be assumed.
- If an identifier appears on the left-hand side of a continuous assignment statement, and that identifier has not been declared previously in the scope where the continuous assignment statement appears or in any scope whose declarations can be directly referenced from the scope where the continuous assignment statement appears (see [23.9](#)), then an implicit scalar net of default net type shall be assumed. See [10.3](#) for a discussion of continuous assignment statements.

The implicit net declaration shall belong to the scope in which the net reference appears. For example, if the implicit net is declared by a reference in a generate block, then the net is implicitly declared only in that generate block. Subsequent references to the net from outside the generate block or in another generate block within the same module either would be illegal or would create another implicit declaration of a different net (depending on whether the reference meets the above criteria). See [Clause 27](#) for information about generate blocks.

See [22.8](#) for a discussion of control of the type for implicitly declared nets with the ``default_nettype` compiler directive.

6.11 Integer data types

SystemVerilog provides several integer data types, as shown in [Table 6-8](#).

Table 6-8—Integer data types

shortint	2-state data type, 16-bit signed integer
int	2-state data type, 32-bit signed integer
longint	2-state data type, 64-bit signed integer
byte	2-state data type, 8-bit signed integer or ASCII character
bit	2-state data type, user-defined vector size
logic	4-state data type, user-defined vector size
reg	4-state data type, user-defined vector size
integer	4-state data type, 32-bit signed integer
time	4-state data type, 64-bit unsigned integer

6.11.1 Integral types

The term *integral* is used throughout this standard to refer to the data types that can represent a single basic integer data type, packed array, packed structure, packed union, enum variable, or time variable.

The term *simple bit vector type* is used throughout this standard to refer to the data types that can directly represent a one-dimensional packed array of bits. The integer types listed in [Table 6-8](#) are simple bit vector types with predefined widths. The packed structure types (see [7.2](#)) and multidimensional packed array types (see [7.4](#)) are not simple bit vector types, but each is equivalent (see [6.22.2](#)) to some simple bit vector type, to and from which it can be easily converted.

6.11.2 2-state (two-value) and 4-state (four-value) data types

Types that can have unknown and high-impedance values are called *4-state types*. These are **logic**, **reg**, **integer**, and **time**. The other types do not have unknown values and are called *2-state types*, for example, **bit** and **int**.

The difference between **int** and **integer** is that **int** is a 2-state type and **integer** is a 4-state type. The 4-state values have additional bits, which encode the x and z states. The 2-state data types can simulate faster, take less memory, and are preferred in some design styles.

The keyword **reg** does not always accurately describe user intent, as it could be perceived to imply a hardware register. The keyword **logic** is a more descriptive term. **logic** and **reg** denote the same type.

Automatic type conversions from a smaller number of bits to a larger number of bits involve zero extensions if unsigned or sign extensions if signed. Automatic type conversions from a larger number of bits to a smaller number of bits involve truncations of the most significant bits (MSBs). When a 4-state value is automatically converted to a 2-state value, any unknown or high-impedance bits shall be converted to zeros.

6.11.3 Signed and unsigned integer types

Integer types use integer arithmetic and can be signed or unsigned. This affects the meaning of certain operators (see [Clause 11](#) on operators and expressions).

The data types `byte`, `shortint`, `int`, `integer`, and `longint` default to signed. The data types `bit`, `reg`, and `logic` default to unsigned, as do arrays of these types. The signedness can be explicitly defined using the keywords `signed` and `unsigned`.

```
int unsigned ui;
int signed si;
```

6.12 Real, shortreal and realtime data types

The `real`¹⁰ data type is the same as a C `double`. The `shortreal` data type is the same as a C `float`. The `realtime` declarations shall be treated synonymously with `real` declarations and can be used interchangeably. Variables of these three types are collectively referred to as *real variables*.

6.12.1 Operators and real numbers

The result of using logical or relational operators on real numbers and real variables is a single-bit scalar value. Not all operators can be used with expressions involving real numbers and real variables (see [11.3.1](#)). Real number constants and real variables are also prohibited in the following cases:

- Edge event controls (`posedge`, `negedge`, `edge`) applied to real variables
- Bit-select or part-select references of variables declared as `real`
- Real number index expressions of bit-select or part-select references of vectors

6.12.2 Conversion

Real numbers shall be converted to integers by rounding the real number to the nearest integer, rather than by truncating it. Implicit conversion shall take place when a real number is assigned to an integer. If the fractional part of the real number is exactly 0.5, it shall be rounded away from zero.

Implicit conversion shall also take place when an expression is assigned to a real. Individual bits that are `x` or `z` in the net or the variable shall be treated as zero upon conversion.

Explicit conversion can be specified using casting (see [6.24](#)) or using system tasks (see [20.5](#)).

6.13 Void data type

The `void` data type represents nonexistent data. This type can be specified as the return type of functions to indicate no return value. This type can also be used for members of tagged unions (see [7.3.2](#)).

6.14 Chandle data type

The `chandle` data type represents storage for pointers passed using the DPI (see [Clause 35](#)). The size of a value of this data type is platform dependent, but shall be at least large enough to hold a pointer on the machine on which the tool is running.

The syntax to declare a handle is as follows:

```
chandle variable_name ;
```

¹⁰The `real` and `shortreal` types are represented as described by IEEE Std 754.

where `variable_name` is a valid identifier. Chandles shall always be initialized to the value `null`, which has a value of 0 on the C side. Chandles are restricted in their usage, with the only legal uses being as follows:

- Only the following operators are valid on **chandle** variables:
 - Equality (`==`), inequality (`!=`) with another **chandle** or with `null`
 - Case equality (`===`), case inequality (`!==`) with another **chandle** or with `null` (same semantics as `==` and `!=`)
- Chandles can be tested for a Boolean value, which shall be 0 if the **chandle** is `null` and 1 otherwise.
- Only the following assignments can be made to a **chandle**:
 - Assignment from another **chandle**
 - Assignment to `null`
- Chandles can be inserted into associative arrays (refer to [7.8](#)), but the relative ordering of any two entries in such an associative array can vary, even between successive runs of the same tool.
- Chandles can be used within a class.
- Chandles can be passed as arguments to subroutines.
- Chandles can be returned from functions.

The use of chandles is restricted as follows:

- Ports shall not have the **chandle** data type.
- Chandles shall not be assigned to variables of any other type.
- Chandles shall not be used as follows:
 - In any expression other than as permitted in this subclause
 - As ports
 - In sensitivity lists or event expressions
 - In continuous assignments
 - In untagged unions
 - In packed types

6.15 Class

A class variable can hold a handle to a class object. Defining classes and creating objects is discussed in [Clause 8](#).

6.16 String data type

The **string** data type is an ordered collection of characters. The length of a **string** variable is the number of characters in the collection. Variables of type **string** are dynamic as their length may vary during simulation. A single character of a **string** variable may be selected for reading or writing by indexing the variable. A single character of a **string** variable is of type **byte**.

SystemVerilog also includes a number of special methods to work with strings, which are defined in this subclause.

A string variable does not represent a string in the same way as a string literal (see [5.9](#)). String literals behave like packed arrays of a width that is a multiple of 8 bits. A string literal assigned to a packed array of an integral variable of a different size is either truncated to the size of the variable or padded with zeros to the left as necessary. When using the **string** data type instead of an integral variable, strings can be of arbitrary length.

trary length and no truncation occurs. String literals are implicitly converted to the **string** type when assigned to a **string** type or used in an expression involving **string** type operands.

The indices of string variables shall be numbered from 0 to $N-1$ (where N is the length of the string) so that index 0 corresponds to the first (leftmost) character of the string and index $N-1$ corresponds to the last (rightmost) character of the string. The string variables can take on the special value "", which is the empty string. Indexing an empty string variable shall be an out-of-bounds access.

A string variable shall not contain the special character "\0". Assigning the value 0 to a string character shall be ignored.

The syntax to declare a string variable is as follows:

```
string variable_name [= initial_value];
```

where `variable_name` is a valid identifier and the optional `initial_value` can be a string literal, the value "" for an empty string, or a string data type expression. For example:

```
parameter string default_name = "John Smith";  
string myName = default_name;
```

If an initial value is not specified in the declaration, the variable is initialized to "", the empty string. An empty string has zero length.

SystemVerilog provides a set of operators that can be used to manipulate combinations of string variables and string literals. The basic operators defined on the **string** data type are listed in [Table 6-9](#).

A string literal can be assigned to a variable of a **string** or an integral data type. When assigning to a variable of integral data type, if the number of bits of the data object is not equal to the number of characters in the string literal multiplied by 8, the literal is right justified and either truncated on the left or zero filled on the left, as necessary. For example:

```
byte c = "A";           // assigns to c "A"  
bit [10:0] b = "\x41";  // assigns to b 'b000_0100_0001  
bit [1:4][7:0] h = "hello" ; // assigns to h "ello"
```

A string literal or an expression of **string** type can be assigned directly to a variable of **string** type (a *string variable*). Values of integral type can be assigned to a string variable, but require a cast. When casting an integral value to a string variable, that variable shall grow or shrink to accommodate the integral value. If the size of the integral value is not a multiple of 8 bits, then the value shall be zero-filled on the left so that its size is a multiple of 8 bits.

A string literal assigned to a string variable is converted according to the following steps:

- All "\0" characters in the string literal are ignored (i.e., removed from the string).
- If the result of the first step is an empty string literal, the string is assigned the empty string.
- Otherwise, the string is assigned the remaining characters in the string literal.

Casting an integral value to a string variable proceeds in the following steps:

- If the size (in bits) of the integral value is not a multiple of 8, the integral value is left extended and filled with zeros until its bit size is a multiple of 8. The extended value is then treated the same as a string literal, where each successive 8 bits represent a character.
- The steps described above for string literal conversion are then applied to the extended value.

For example:

```
string s0 = "String literal assign";// sets s0 to "String literal assign"
string s1 = "hello\0world";          // sets s1 to "helloworld"
bit [11:0] b = 12'ha41;
string s2 = string'(b);              // sets s2 to 16'h0a41
```

As a second example:

```
typedef logic [15:0] r_t;
r_t r;
integer i = 1;
string b = "";
string a = {"Hi", b};

r = r_t'(a);          // OK
b = string'(r);      // OK
b = "Hi";            // OK
b = {5{"Hi"}};       // OK
a = {i{"Hi"}};       // OK (non-constant replication)
r = {i{"Hi"}};       // invalid (non-constant replication)
a = {i{b}};          // OK
a = {a,b};           // OK
a = {"Hi",b};        // OK
r = {"H", ""};       // yields "H\0". "" is converted to 8'b0
b = {"H", ""};       // yields "H". "" is the empty string
a[0] = "h";          // OK, same as a[0] = "cough"
a[0] = b;            // invalid, requires a cast
a[1] = "\0";         // ignored, a is unchanged
```

Table 6-9—String operators

Operator	Semantics
Str1 == Str2	<i>Equality.</i> Checks whether the two string operands are equal. Result is 1 if they are equal and 0 if they are not. Both operands can be expressions of string type, or one can be an expression of string type and the other can be a string literal, which shall be implicitly converted to string type for the comparison. If both operands are string literals, the operator is the same equality operator as for integral types.
Str1 != Str2	<i>Inequality.</i> Logical negation of ==
Str1 < Str2 Str1 <= Str2 Str1 > Str2 Str1 >= Str2	<i>Comparison.</i> Relational operators return 1 if the corresponding condition is true using the lexicographic ordering of the two strings Str1 and Str2. The comparison uses the compare string method. Both operands can be expressions of string type, or one can be an expression of string type and the other can be a string literal, which shall be implicitly converted to string type for the comparison. If both operands are string literals, the operator is the same comparison operator as for integral types.
{Str1, Str2, ..., Strn}	<i>Concatenation.</i> Each operand can be a string literal or an expression of string type. If all the operands are string literals the expression shall behave as a concatenation of integral values; if the result of such a concatenation is used in an expression involving string types then it shall be implicitly converted to string type. If at least one operand is an expression of string type, then any operands that are string literals shall be converted to string type before the concatenation is performed, and the result of the concatenation shall be of string type.

Table 6-9—String operators (continued)

Operator	Semantics
{multiplier{Str}}	<i>Replication:</i> Str can be a string literal or an expression of string type. multiplier shall be an expression of integral type, and is not required to be a constant expression. If multiplier is non-constant or Str is an expression of string type, the result is a string containing <i>N</i> concatenated copies of Str, where <i>N</i> is specified by the multiplier. If Str is a literal and the multiplier is constant, the expression behaves like numeric replication (if the result is used in another expression involving string types, it is implicitly converted to the string type).
Str[index]	<i>Indexing.</i> Returns a byte, the ASCII code at the given index. Indices range from 0 to <i>N</i> -1, where <i>N</i> is the number of characters in the string. If given an index out of range, returns 0. Semantically equivalent to Str.getc(index), in 6.16.3 .
Str.method(...)	The dot (.) operator is used to invoke a specified method on strings.

SystemVerilog also includes a number of special methods to work with strings, which use the built-in method notation. These methods are described in [6.16.1](#) through [6.16.15](#).

6.16.1 Len()

```
function int len();
```

- str.len() returns the length of the string, i.e., the number of characters in the string (excluding any terminating character).
- If str is "", then str.len() returns 0.

6.16.2 Putc()

```
function void putc(int i, byte c);
```

- str.putc(i, c) replaces the *i*th character in *str* with the given integral value.
- putc does not change the size of *str*: If $i < 0$ or $i \geq \text{str.len}()$, then *str* is unchanged.
- if the second argument to putc is zero, the string is unaffected.

The putc method assignment `str.putc(j, x)` is semantically equivalent to `str[j] = x`.

6.16.3 Getc()

```
function byte getc(int i);
```

- str.getc(i) returns the ASCII code of the *i*th character in *str*.
- If $i < 0$ or $i \geq \text{str.len}()$, then str.getc(i) returns 0.

The getc method assignment `x = str.getc(j)` is semantically equivalent to `x = str[j]`.

6.16.4 Toupper()

```
function string toupper();
```

- str.toupper() returns a string with characters in *str* converted to uppercase.

- `str` is unchanged.

6.16.5 Tolower()

```
function string tolower();
```

- `str.tolower()` returns a string with characters in `str` converted to lowercase.
- `str` is unchanged.

6.16.6 Compare()

```
function int compare(string s);
```

- `str.compare(s)` compares `str` and `s`, as in the ANSI C `strcmp` function with regard to lexical ordering and return value.

See the relational string operators in [Table 6-9](#).

6.16.7 Icompare()

```
function int icode(string s);
```

- `str.icode(s)` compares `str` and `s`, like the ANSI C `strcmp` function with regard to lexical ordering and return value, but the comparison is case insensitive.

6.16.8 Substr()

```
function string substr(int i, int j);
```

- `str.substr(i, j)` returns a new string that is a substring formed by characters in position `i` through `j` of `str`.
- If `i < 0`, `j < i`, or `j >= str.len()`, `substr()` returns "" (the empty string).

6.16.9 Atoi(), atohex(), atooc(), atobin()

```
function integer atoi();  
function integer atohex();  
function integer atooc();  
function integer atobin();
```

- `str.atoi()` returns the integer corresponding to the ASCII decimal representation in `str`. For example:

```
str = "123";  
int i = str.atoi(); // assigns 123 to i.
```

The conversion scans all leading digits and underscore characters (`_`) and stops as soon as it encounters any other character or the end of the string. It returns zero if no digits were encountered. It does not parse the full syntax for integer literals (sign, size, apostrophe, base).

- `atohex` interprets the string as hexadecimal.
- `atooc` interprets the string as octal.
- `atobin` interprets the string as binary.

NOTE—These ASCII conversion functions return a 32-bit integer value. Truncation is possible without warning. For converting integer values greater than 32-bits, see `$sscanf` in [21.3.4](#).

6.16.10 `atoreal()`

```
function real atoreal();
```

- `str.atoreal()` returns the real number corresponding to the ASCII decimal representation in `str`.

The conversion parses for real constants. The scan stops as soon as it encounters any character that does not conform to this syntax or the end of the string. It returns zero if no digits were encountered.

6.16.11 `ltoa()`

```
function void ltoa(integer i);
```

- `str.ltoa(i)` stores the ASCII decimal representation of `i` into `str` (inverse of `atoi`).

6.16.12 `hextoa()`

```
function void hextoa(integer i);
```

- `str.hextoa(i)` stores the ASCII hexadecimal representation of `i` into `str` (inverse of `atohex`).

6.16.13 `octtoa()`

```
function void octtoa(integer i);
```

- `str.octtoa(i)` stores the ASCII octal representation of `i` into `str` (inverse of `atooct`).

6.16.14 `bintoa()`

```
function void bintoa(integer i);
```

- `str.bintoa(i)` stores the ASCII binary representation of `i` into `str` (inverse of `atobin`).

6.16.15 `realtoa()`

```
function void realtoa(real r);
```

- `str.realtoa(r)` stores the ASCII real representation of `r` into `str` (inverse of `atoreal`).

6.17 Event data type

An event object gives a powerful and efficient means of describing the communication between, and synchronization of, two or more concurrently active processes. A basic example of this is a small waveform clock generator that synchronizes control of a synchronous circuit by signaling the occurrence of an explicit event periodically while the circuit waits for the event to occur.

The **event** data type provides a handle to a synchronization object. The object referenced by an event variable can be explicitly triggered and waited for. Furthermore, event variables have a persistent triggered state

that lasts for the duration of the entire time step. Its occurrence can be recognized by using the event control syntax described in [9.4.2](#).

An event variable can be assigned or compared to another event variable or assigned the special value `null`. When assigned another event variable, both event variables refer to the same synchronization object. When assigned `null`, the association between the synchronization object and the event variable is broken.

If an initial value is not specified in the declaration of an event variable, then the variable is initialized to a new synchronization object.

Examples:

```
event done;                // declare a new event called done
event done_too = done;     // declare done_too as alias to done
event empty = null;       // event variable with no synchronization object
```

Event operations and semantics are discussed in detail in [15.5](#).

6.18 User-defined types

SystemVerilog's data types can be extended with user-defined types using `typedef`. The syntax for declaring user-defined types is shown in [Syntax 6-3](#).

```
type_declaration ::=                                     //from A.2.1.3
  typedef data_type type_identifier { variable_dimension } ;
  | typedef interface_instance_identifier constant_bit_select . type_identifier type_identifier ;
  | typedef [ enum | struct | union | class ] type_identifier ;
```

Syntax 6-3—User-defined types (excerpt from [Annex A](#))

A `typedef` may be used to give a user-defined name to an existing data type. For example:

```
typedef int intP;
```

The named data type can then be used as follows:

```
intP a, b;
```

User-defined data type names must be used for complex data types in casting (see [6.24](#)), which only allows simple data type names, and as type parameter values (see [6.20.3](#)) when unpacked array types are used.

A type parameter may also be used to declare a *type identifier*. The declaration of a user-defined data type shall precede any reference to its *type identifier*. User-defined data type identifiers have the same scoping rules as data identifiers, except that hierarchical references to *type identifier* shall not be allowed. References to type identifiers defined within an interface through ports are not considered hierarchical references and are allowed provided they are locally redefined before being used. Such a `typedef` is called an *interface based typedef*.

```
interface intf_i;
  typedef int data_t;
endinterface

module sub(intf_i p);
```

```

typedef p.data_t my_data_t;
my_data_t data;
    // type of 'data' will be int when connected to interface above
endmodule

```

Sometimes a user-defined type needs to be declared before the contents of the type have been defined. This is of use with user-defined types derived from the basic data types: **enum**, **struct**, **union**, and **class**. Support for this is provided by the following forms for a *forward typedef*:

```

typedef enum type_identifier;
typedef struct type_identifier;
typedef union type_identifier;
typedef class type_identifier;
typedef type_identifier;

```

NOTE—While an empty user-defined type declaration is useful for coupled definitions of classes as shown in 8.25, it cannot be used for coupled definitions of structures because structures are statically declared and there is no support for handles to structures.

The last form shows that the basic data type of the user-defined type does not have to be defined in the forward declaration.

The actual data type definition of a forward **typedef** declaration shall be resolved within the same local scope or **generate** block. It shall be an error if the *type_identifier* does not resolve to a data type. It shall be an error if a basic data type was specified by the forward type declaration and the actual type definition does not conform to the specified basic data type. It shall be legal to have a forward type declaration in the same scope, either before or after the final type definition. It shall be legal to have multiple forward type declarations for the same type identifier in the same scope. The use of the term *forward* type declaration does not require the forward type declaration to precede the final type definition.

A forward typedef shall be considered incomplete prior to the final type definition. While incomplete forward types, type parameters, and types defined by an interface based typedef may resolve to class types, use of the class scope resolution operator (see 8.22) to select a type with such a prefix shall be restricted to a typedef declaration. It shall be an error if the prefix does not resolve to a class.

Example:

```

typedef C;
C::T x;           // illegal; C is an incomplete forward type
typedef C::T c_t; // legal; reference to C::T is made by a typedef
c_t y;
class C;
    typedef int T;
endclass

```

6.19 Enumerations

Enumerated types shall be defined using the syntax shown in [Syntax 6-4](#).

```

data_type ::= // from A.2.2.1
...
| enum [ enum_base_type ] { enum_name_declaration { , enum_name_declaration } }
    { packed_dimension }
...
enum_base_type ::=

```

```
integer_atom_type [ signing ]  
| integer_vector_type [ signing ] [ packed_dimension ]  
| type_identifier [ packed_dimension ]14  
enum_name_declaration ::=  
enum_identifier [ [ : integral_number [ : integral_number ] ] ] [ = constant_expression ]
```

¹⁴⁾ A `type_identifier` shall be legal as an `enum_base_type` if it denotes an `integer_atom_type`, with which an additional packed dimension is not permitted, or an `integer_vector_type`.

Syntax 6-4—Enumerated types (excerpt from [Annex A](#))

An enumerated type declares a set of integral named constants. Enumerated data types provide the capability to abstractly declare strongly typed variables without either a data type or data value(s) and later add the required data type and value(s) for designs that require more definition. Enumerated data types also can be easily referenced or displayed using the enumerated names as opposed to the enumerated values.

In the absence of a data type declaration, the default data type shall be `int`. Any other data type used with enumerated types shall require an explicit data type declaration.

An enumerated type defines a set of named values. In the following example, `light1` and `light2` are defined to be variables of the anonymous (unnamed) enumerated `int` type that includes the three members: `red`, `yellow`, and `green`.

```
enum {red, yellow, green} light1, light2; // anonymous int type
```

An enumerated name with `x` or `z` assignments assigned to an `enum` with no explicit data type or an explicit 2-state declaration shall be a syntax error.

```
// Syntax error: IDLE=2'b00, XX=2'bx <ERROR>, S1=2'b01, S2=2'b10  
enum bit [1:0] {IDLE, XX='x, S1=2'b01, S2=2'b10} state, next;
```

An `enum` declaration of a 4-state type, such as `integer`, that includes one or more names with `x` or `z` assignments shall be permitted.

```
// Correct: IDLE=0, XX='x, S1=1, S2=2  
enum integer {IDLE, XX='x, S1='b01, S2='b10} state, next;
```

An unassigned enumerated name that follows an `enum` name with `x` or `z` assignments shall be a syntax error.

```
// Syntax error: IDLE=0, XX='x, S1=??, S2=??  
enum integer {IDLE, XX='x, S1, S2} state, next;
```

The values can be cast to integer types and increment from an initial value of 0. This can be overridden.

```
enum {bronze=3, silver, gold} medal; // silver=4, gold=5
```

The values can be set for some of the names and not set for other names. The optional value of an `enum` named constant is an elaboration time constant expression (see [6.20](#)) and can include references to parameters, local parameters, genvars, other `enum` named constants, and constant functions of these. Hierarchical names and `const` variables are not allowed. A name without a value is automatically assigned an increment of the value of the previous name. It shall be an error to automatically increment the maximum representable value of the `enum`.

```
// c is automatically assigned the increment-value of 8
```

```
enum {a=3, b=7, c} alphabet;
```

Both the enumeration names and their integer values shall be unique. It shall be an error to set two values to the same name or to set the same value to two names, regardless of whether the values are set explicitly or by automatic incrementing.

```
// Error: c and d are both assigned 8
enum {a=0, b=7, c, d=8} alphabet;
```

If the first name is not assigned a value, it is given the initial value of 0.

```
// a=0, b=7, c=8
enum {a, b=7, c} alphabet;
```

The integer value expressions are evaluated in the context of a cast to the `enum` base type. Any enumeration encoding value that is outside the representable range of the `enum` base type shall be an error. For an unsigned base type, this occurs if the cast truncates the value and any of the discarded bits are nonzero. For a signed base type, this occurs if the cast truncates the value and any of the discarded bits are not equal to the sign bit of the result. If the integer value expression is a sized literal constant, it shall be an error if the size is different from the `enum` base type, even if the value is within the representable range. The value after the cast is the value used for the name, including in the uniqueness check and automatic incrementing to get a value for the next name.

```
// Correct declaration - bronze and gold are unsized
enum bit [3:0] {bronze='h3, silver, gold='h5} medal2;

// Correct declaration - bronze and gold sizes are redundant
enum bit [3:0] {bronze=4'h3, silver, gold=4'h5} medal3;

// Error in the bronze and gold member declarations
enum bit [3:0] {bronze=5'h13, silver, gold=3'h5} medal4;

// Error in c declaration, requires at least 2 bits
enum bit [0:0] {a,b,c} alphabet;
```

Type checking of enumerated types used in assignments, as arguments, and with operators is covered in [6.19.3](#). As in C, there is no overloading of literals; therefore, `medal2` and `medal3` cannot be defined in the same scope because they contain the same names.

6.19.1 Defining new data types as enumerated types

A type name can be given so that the same type can be used in many places.

```
typedef enum {NO, YES} boolean;
boolean myvar; // named type
```

6.19.2 Enumerated type ranges

A range of enumeration elements can be specified automatically, via the syntax shown in [Table 6-10](#).

Table 6-10—Enumeration element ranges

name	Associates the next consecutive number with name.
name = C	Associates the constant C to name.

Table 6-10—Enumeration element ranges (continued)

name [N]	Generates N named constants in the sequence: name0, name1,..., nameN-1. N shall be a positive integral number.
name [N] = C	Optionally, a constant can be assigned to the generated named constants to associate that constant to the first generated named constant; subsequent generated named constants are associated consecutive values. N shall be a positive integral number.
name [N:M]	Creates a sequence of named constants starting with nameN and incrementing or decrementing until reaching named constant nameM. N and M shall be nonnegative integral numbers.
name [N:M] = C	Optionally, a constant can be assigned to the generated named constants to associate that constant to the first generated named constants; subsequent generated named constants are associated consecutive values. N and M shall be nonnegative integral numbers.

For example:

```
typedef enum { add=10, sub[5], jmp[6:8] } E1;
```

This example defines the enumerated type `E1`, which assigns the number 10 to the enumerated named constant `add`. It also creates the enumerated named constants `sub0`, `sub1`, `sub2`, `sub3`, and `sub4` and assigns them the values 11...15, respectively. Finally, the example creates the enumerated named constants `jmp6`, `jmp7`, and `jmp8` and assigns them the values 16 through 18, respectively.

```
enum { register[2] = 1, register[2:4] = 10 } vr;
```

The example above declares enumerated variable `vr`, which creates the enumerated named constants `register0` and `register1`, which are assigned the values 1 and 2, respectively. Next, it creates the enumerated named constants `register2`, `register3`, and `register4` and assigns them the values 10, 11, and 12.

6.19.3 Type checking

Enumerated types are strongly typed; thus, a variable of type `enum` cannot be directly assigned a value that lies outside the enumeration set unless an explicit cast is used or unless the `enum` variable is a member of a union. This is a powerful type-checking aid, which prevents users from accidentally assigning nonexistent values to variables of an enumerated type. The enumeration values can still be used as constants in expressions, and the results can be assigned to any variable of a compatible integral type.

Enumerated variables are type-checked in assignments, arguments, and relational operators. Enumerated variables are auto-cast into integral values, but assignment of arbitrary expressions to an enumerated variable requires an explicit cast.

For example:

```
typedef enum { red, green, blue, yellow, white, black } Colors;
```

This operation assigns a unique number to each of the color identifiers and creates the new data type `Colors`. This type can then be used to create variables of that type.

```
Colors c;  
c = green;  
c = 1;           // Invalid assignment
```

```
if ( 1 == c )    // OK. c is auto-cast to integer
```

In the example above, the value `green` is assigned to the variable `c` of type `Colors`. The second assignment is invalid because of the strict typing rules enforced by enumerated types.

Casting can be used to perform an assignment of a different data type, or an out-of-range value, to an enumerated type. Casting is discussed in [6.19.4](#), [6.24.1](#), and [6.24.2](#).

6.19.4 Enumerated types in numerical expressions

Elements of enumerated type variables can be used in numerical expressions. The value used in the expression is the numerical value associated with the enumerated value. For example:

```
typedef enum { red, green, blue, yellow, white, black } Colors;

Colors col;
integer a, b;

a = blue * 3;
col = yellow;
b = col + green;
```

From the previous declaration, `blue` has the numerical value 2. This example assigns `a` the value of 6 ($2*3$), and it assigns `b` a value of 4 ($3+1$).

An `enum` variable or identifier used as part of an expression is automatically cast to the base type of the `enum` declaration (either explicitly or using `int` as the default). A cast shall be required for an expression that is assigned to an `enum` variable where the type of the expression is not equivalent to the enumeration type of the variable.

Casting to an `enum` type shall cause a conversion of the expression to its base type without checking the validity of the value (unless a dynamic cast is used as described in [6.24.2](#)).

```
typedef enum {Red, Green, Blue} Colors;
typedef enum {Mo,Tu,We,Th,Fr,Sa,Su} Week;
Colors C;
Week W;
int I;

C = Colors'(C+1);           // C is converted to an integer, then added to
                           // one, then converted back to a Colors type

C = C + 1; C++; C+=2; C = I; // Illegal because they would all be
                           // assignments of expressions without a cast

C = Colors'(Su);           // Legal; puts an out of range value into C

I = C + W;                 // Legal; C and W are automatically cast to int
```

6.19.5 Enumerated type methods

SystemVerilog includes a set of specialized methods to enable iterating over the values of enumerated types, which are defined in [6.19.5.1](#) through [6.19.5.6](#).

6.19.5.1 First()

The prototype for the `first()` method is as follows:

```
function enum first();
```

The `first()` method returns the value of the first member of the enumeration.

6.19.5.2 Last()

The prototype for the `last()` method is as follows:

```
function enum last();
```

The `last()` method returns the value of the last member of the enumeration.

6.19.5.3 Next()

The prototype for the `next()` method is as follows:

```
function enum next( int unsigned N = 1 );
```

The `next()` method returns the Nth next enumeration value (default is the next one) starting from the current value of the given variable. A wrap to the start of the enumeration occurs when the end of the enumeration is reached. If the given value is not a member of the enumeration, the `next()` method returns the default initial value for the enumeration (see [Table 6-7](#)).

6.19.5.4 Prev()

The prototype for the `prev()` method is as follows:

```
function enum prev( int unsigned N = 1 );
```

The `prev()` method returns the Nth previous enumeration value (default is the previous one) starting from the current value of the given variable. A wrap to the end of the enumeration occurs when the start of the enumeration is reached. If the given value is not a member of the enumeration, the `prev()` method returns the default initial value for the enumeration (see [Table 6-7](#)).

6.19.5.5 Num()

The prototype for the `num()` method is as follows:

```
function int num();
```

The `num()` method returns the number of elements in the given enumeration.

6.19.5.6 Name()

The prototype for the `name()` method is as follows:

```
function string name();
```

The `name()` method returns the string representation of the given enumeration value. If the given value is not a member of the enumeration, the `name()` method returns the empty string.

6.19.5.7 Using enumerated type methods

The following code fragment shows how to display the name and value of all the members of an enumeration:

```
typedef enum { red, green, blue, yellow } Colors;
Colors c = c.first;
forever begin
    $display( "%s : %d\n", c.name, c );
    if( c == c.last ) break;
    c = c.next;
end
```

6.20 Constants

Constants are named data objects that never change. SystemVerilog provides three elaboration-time constants: `parameter`, `localparam`, and `specparam`. SystemVerilog also provides a run-time constant, `const` (see [6.20.6](#)).

The `parameter`, `localparam`, and `specparam` constants are collectively referred to as *parameter* constants.

Parameter constants can be initialized with a literal.

```
localparam byte colon1 = ":" ;
specparam delay = 10 ; // specparams are used for specify blocks
parameter logic flag = 1 ;
```

SystemVerilog provides four methods for setting the value of parameter constants. Each parameter may be assigned a default value when declared. The value of a parameter of an instantiated module, interface or program can be overridden in each instance using one of the following:

- Assignment by ordered list (e.g., `m #(value, value) u1 (...);`) (see [23.10.2.1](#))
- Assignment by name
(e.g., `m #(.param1(value), .param2(value)) u1 (...);`) (see [23.10.2.2](#))
- `defparam` statements, using hierarchical path names to redefine each parameter (see [23.10.1](#))

NOTE—The `defparam` statement might be removed from future versions of the language. See [C.4.1](#).

6.20.1 Parameter declaration syntax

```
local_parameter_declaration ::= // from A.2.1.1
    localparam data_type_or_implicit list_of_param_assignments
    | localparam type list_of_type_assignments
parameter_declaration ::=
    parameter data_type_or_implicit list_of_param_assignments
    | parameter type list_of_type_assignments
specparam_declaration ::=
    specparam [ packed_dimension ] list_of_specparam_assignments ;
data_type_or_implicit ::= // from A.2.2.1
    data_type
    | implicit_data_type
```

```

implicit_data_type ::= [ signing ] { packed_dimension }
list_of_param_assignments ::= param_assignment { , param_assignment } //from A.2.3
list_of_specparam_assignments ::= specparam_assignment { , specparam_assignment }
list_of_type_assignments ::= type_assignment { , type_assignment }
param_assignment ::= //from A.2.4
    parameter_identifier { unpacked_dimension } [ = constant_param_expression ]18
specparam_assignment ::=
    specparam_identifier = constant_mintypmax_expression
    | pulse_control_specparam
type_assignment ::=
    type_identifier [ = data_type ]18
parameter_port_list ::= //from A.1.3
    # ( list_of_param_assignments { , parameter_port_declaration } )
    | # ( parameter_port_declaration { , parameter_port_declaration } )
    | # ( )
parameter_port_declaration ::=
    parameter_declaration
    | local_parameter_declaration
    | data_type list_of_param_assignments
    | type list_of_type_assignments

```

¹⁸⁾ In a `param_assignment` it shall be illegal to omit the `constant_param_expression` except within a `parameter_declaration` in a `parameter_port_list`. In a `type_assignment` it shall be illegal to omit the `data_type` except within a `parameter_declaration` in a `parameter_port_list`.

Syntax 6-5—Parameter declaration syntax (excerpt from Annex A)

The *list_of_param_assignments* can appear in a module, interface, program, class, or package or in the *parameter_port_list* of a module (see 23.2), interface, program, or class. If the declaration of a design element uses a *parameter_port_list* (even an empty one), then in any *parameter_declaration* directly contained within the declaration, the **parameter** keyword shall be a synonym for the **localparam** keyword (see 6.20.4). All *param_assignments* appearing within a class body shall become **localparam** declarations regardless of the presence or absence of a *parameter_port_list*. All *param_assignments* appearing within a package shall become **localparam** declarations.

The **parameter** keyword can be omitted in a parameter port list. For example:

```

class vector #(size = 1); // size is a parameter in a parameter port list
    logic [size-1:0] v;
endclass

interface simple_bus #(AWIDTH = 64, type T = word) // parameter port list
    (input logic clk) ; // port list
    ...
endinterface

```

In a list of parameter constants, a parameter can depend on earlier parameters. In the following declaration, the default value of the second parameter depends on the value of the first parameter. The third parameter is a type, and the fourth parameter is a value of that type.

```

module mc #(int N = 5, M = N*16, type T = int, T x = 0)
    ( ... );

```

```
...
endmodule
```

In the declaration of a parameter in a parameter port list, the specification for its default value may be omitted, in which case the parameter shall have no default value. If no default value is specified for a parameter of a design element, then an overriding parameter value shall be specified in every instantiation of that design element (see [23.10](#)). Also, if no default value is specified for a parameter of a design element, then a tool shall not implicitly instantiate that design element (see [23.3](#), [23.4](#), and [24.3](#)). If no default value is specified for a parameter of a class, then an overriding parameter value shall be specified in every specialization of that class (see [8.24](#)).

```
class Mem #(type T, int size);
    T words[size];
    ...
endclass

typedef Mem#(byte, 1024) Kbyte;
```

6.20.2 Value parameters

A parameter constant can have a *type* specification and a *range* specification. The type and range of parameters shall be in accordance with the following rules:

- A parameter declaration with no type or range specification shall default to the type and range of the final value assigned to the parameter, after any value overrides have been applied. If the expression is real, the parameter is real. If the expression is integral, the parameter is a **logic** vector of the same size with range `[size-1:0]`.
- A parameter with a range specification, but with no type specification, shall have the range of the parameter declaration and shall be unsigned. The sign and range shall not be affected by value overrides.
- A parameter with a type specification, but with no range specification, shall be of the type specified. A signed parameter shall default to the range of the final value assigned to the parameter, after any value overrides have been applied.
- A parameter with a signed type specification and with a range specification shall be signed and shall have the range of its declaration. The sign and range shall not be affected by value overrides.
- A parameter with no range specification and with either a signed type specification or no type specification shall have an implied range with an *lsb* equal to 0 and an *msb* equal to one less than the size of the final value assigned to the parameter.
- A parameter with no range specification, with either a signed type specification or no type specification, and for which the final value assigned to it is unsized shall have an implied range with an *lsb* equal to 0 and an *msb* equal to an implementation-dependent value of at least 31.

In an assignment to, or override of, a parameter with an explicit type declaration, the type of the right-hand expression shall be assignment compatible with the declared type (see [6.22.3](#)).

The conversion rules between real and integer values described in [6.12.2](#) apply to parameters as well.

Bit-selects and part-selects of parameters that are of integral types shall be allowed (see [6.11.1](#)).

A value parameter (**parameter**, **localparam**, or **specparam**) can only be set to an expression of literals, value parameters or local parameters, genvars, enumerated names, or a constant function of these. Package references are allowed. Hierarchical names are not allowed. A **specparam** can also be set to an expression containing one or more **specparams**.

Examples:

```

parameter msb = 7; // defines msb as a constant value 7
parameter e = 25, f = 9; // defines two constant numbers
parameter r = 5.7; // declares r as a real parameter
parameter byte_size = 8,
byte_mask = byte_size - 1;
parameter average_delay = (r + f) / 2;

parameter signed [3:0] mux_selector = 0;
parameter real r1 = 3.5e17;
parameter p1 = 13'h7e;
parameter [31:0] dec_const = 1'b1; // value converted to 32 bits
parameter newconst = 3'h4; // implied range of [2:0]
parameter newconst = 4; // implied range of at least [31:0]

```

A parameter can also be declared as an aggregate type, such as an unpacked array or an unpacked structure. An aggregate parameter must be assigned to or overridden as a whole; individual members of an aggregate parameter may not be assigned or overridden separately. However, an individual member of an aggregate parameter may be used in an expression. For example:

```

parameter logic [31:0] P1 [3:0] = '{ 1, 2, 3, 4 } ; // unpacked array
// parameter declaration
initial begin
if ( P1[2][7:0] ) ... // use part-select of individual element of the array

```

6.20.2.1 \$ as a parameter value

The value \$ can be assigned to parameters of integer types. A parameter to which \$ is assigned shall only be used wherever \$ can be specified as a literal constant.

For example, \$ represents unbounded range specification, where the upper index can be any integer.

```

parameter r2 = $;
property inq1(r1,r2);
@(posedge clk) a ##[r1:r2] b ##1 c |=> d;
endproperty
assert inq1(3);

```

A system function is provided to test whether a constant is a \$. The syntax of the system function is

```
$isunbounded(constant_expression);
```

\$isunbounded returns true if *constant expression* is unbounded. Typically, \$isunbounded would be used as a condition in the generate statement.

The example below illustrates the benefit of using \$ in writing properties concisely where the range is parameterized. The checker in the example verifies that a bus driven by signal *en* remains 0, i.e. quiet for the specified minimum (*min_quiet*) and maximum (*max_quiet*) quiet time.

NOTE—The function \$isunbounded is used for checking the validity of the actual arguments.

```

interface quiet_time_checker #(parameter min_quiet = 0,
parameter max_quiet = 0)
(input logic clk, reset_n, logic [1:0]en);

generate

```

```

if ( max_quiet == 0) begin
  property quiet_time;
    @(posedge clk) reset_n |-> ($countones(en) == 1);
  endproperty
  a1: assert property (quiet_time);
end
else begin
  property quiet_time;
    @(posedge clk)
      (reset_n && ($past(en) != 0) && en == 0)
      |->(en == 0) [*min_quiet:max_quiet]
      ##1 ($countones(en) == 1);
  endproperty
  a1: assert property (quiet_time);
end
if ((min_quiet == 0) && ($isunbounded(max_quiet))
  $display(warning_msg);
endgenerate
endinterface

quiet_time_checker #(0, 0) quiet_never (clk,1,enables);
quiet_time_checker #(2, 4) quiet_in_window (clk,1,enables);
quiet_time_checker #(0, $) quiet_any (clk,1,enables);

```

Another example below illustrates that by testing for \$, a property can be configured according to the requirements. When parameter max_cks is unbounded, it is not required to test for expr to become false.

```

interface width_checker #(parameter min_cks = 1, parameter max_cks = 1)
  (input logic clk, reset_n, expr);

  generate
    if ($isunbounded(max_cks)) begin
      property width;
        @(posedge clk)
          (reset_n && $rose(expr)) |-> (expr [* min_cks]);
      endproperty
      a2: assert property (width);
    end
    else begin
      property assert_width_p;
        @(posedge clk)
          (reset_n && $rose(expr)) |-> (expr[* min_cks:max_cks])
          ##1 (!expr);
      endproperty
      a2: assert property (width);
    end
  endgenerate
endinterface

width_checker #(3, $) max_width_unspecified (clk,1,enables);
width_checker #(2, 4) width_specified (clk,1,enables);

```

6.20.3 Type parameters

A parameter constant can also specify a data type, allowing modules, interfaces or programs to have ports and data objects whose type is set for each instance.

```
module ma    #( parameter p1 = 1, parameter type p2 = shortint )
              (input logic [p1:0] i, output logic [p1:0] o);
  p2 j = 0; // type of j is set by a parameter, (shortint unless redefined)
  always @(i) begin
    o = i;
    j++;
  end
endmodule

module mb;
  logic [3:0] i,o;
  ma #(.p1(3), .p2(int)) u1(i,o); //redefines p2 to a type of int
endmodule
```

In an assignment to, or override of, a type parameter, the right-hand expression shall represent a data type.

A data-type parameter (**parameter type**) can only be set to a data type. Package references are allowed. Hierarchical names are not allowed.

It shall be illegal to override a type parameter with a **defparam** statement.

6.20.4 Local parameters (**localparam**)

Local parameters are identical to parameters except that they cannot directly be modified by **defparam** statements (see [23.10.1](#)) or instance parameter value assignments (see [23.10.2](#)). Local parameters can be assigned constant expressions (see [11.2.1](#)) containing parameters, which in turn *can* be modified with **defparam** statements or instance parameter value assignments.

Unlike nonlocal parameters, local parameters can be declared in a **generate** block, package, class body, or compilation-unit scope. In these contexts, the **parameter** keyword can be used as a synonym for the **localparam** keyword.

Local parameters may be declared in a module's *parameter_port_list*. Any parameter declaration appearing in such a list between a **localparam** keyword and the next **parameter** keyword (or the end of the list, if there is no next **parameter** keyword) shall be a local parameter. Any other parameter declaration in such a list shall be a nonlocal parameter that may be overridden as described in [23.10](#).

6.20.5 Specify parameters

The keyword **specparam** declares a special type of parameter that is intended only for providing timing and delay values, but can appear in any expression that is not assigned to a parameter and is not part of the range specification of a declaration. Specify parameters (also called *specparams*) are permitted both within the specify block (see [Clause 30](#)) and in the main module body.

A specify parameter declared outside a specify block shall be declared before it is referenced. The value assigned to a specify parameter can be any constant expression. A specify parameter can be used as part of a constant expression for a subsequent specify parameter declaration. Unlike the **parameter** constant, a specify parameter cannot be modified from within the language, but it can be modified through SDF annotation (see [Clause 32](#)).

Specify parameters and **parameter** constants are not interchangeable. In addition, **parameter** and **localparam** shall not be assigned a constant expression that includes any specify parameters. [Table 6-11](#) summarizes the differences between the two types of parameter declarations.

Table 6-11—Differences between specparams and parameters

Specparams (specify parameter)	Parameters
Use keyword specparam	Use keyword parameter
Shall be declared <i>inside</i> a module or specify block	Shall be declared <i>outside</i> specify blocks
May only be used inside a module or specify block	May not be used inside specify blocks
May be assigned specparams and parameters	May not be assigned specparams
Use SDF annotation to override values	Use defparam or instance declaration parameter value passing to override values

A specify parameter can have a range specification. The range of specify parameters shall be in accordance with the following rules:

- A **specparam** declaration with no range specification shall default to the range of the final value assigned to the parameter, after any value overrides have been applied.
- A **specparam** with a range specification shall have the range of the parameter declaration. The range shall not be affected by value overrides.

Examples:

```

specify
  specparam tRise_clk_q = 150, tFall_clk_q = 200;
  specparam tRise_control = 40, tFall_control = 50;
endspecify
    
```

The lines between the keywords **specify** and **endspecify** declare four specify parameters. The first line declares specify parameters called `tRise_clk_q` and `tFall_clk_q` with values 150 and 200, respectively; the second line declares `tRise_control` and `tFall_control` specify parameters with values 40 and 50, respectively.

```

module RAM16GEN ( output [7:0] DOUT,
                  input [7:0] DIN,
                  input [5:0] ADR,
                  input WE, CE);
  specparam dhold = 1.0;
  specparam ddly = 1.0;
  parameter width = 1;
  parameter regsize = dhold + 1.0; // Illegal - cannot assign
                                   // specparams to parameters
endmodule
    
```

6.20.6 Const constants

A **const** form of constant differs from a **localparam** constant in that the **localparam** shall be set during elaboration, whereas a **const** can be set during simulation, such as in an automatic task.

A static constant declared with the **const** keyword can be set to an expression of literals, parameters, local parameters, genvars, enumerated names, a constant function of these, or other constants. Hierarchical names are allowed because constants declared with the **const** keyword are calculated after elaboration.

```
const logic option = a.b.c ;
```

An automatic constant declared with the **const** keyword can be set to any expression that would be legal without the **const** keyword.

An instance of a class (an object handle) can also be declared with the **const** keyword.

```
const class_name object = new(5,3);
```

In other words, the object acts like a variable that cannot be written. The arguments to the **new** method shall be constant expressions (see [11.2.1](#)). The members of the object can be written (except for those members that are declared **const**).

6.21 Scope and lifetime

Variables declared outside a module, program, interface, checker, task, or function are local to the compilation unit and have a static lifetime (exist for the whole simulation). This is roughly equivalent to C static variables declared outside a function, which are local to a file. Variables declared inside a module, interface, program, or checker, but outside a task, process, or function, are local in scope and have a static lifetime.

Variables declared inside a static task, function, or block are local in scope and default to a static lifetime. Specific variables within a static task, function, or block can be explicitly declared as automatic. Such variables have the lifetime of the call or block and are initialized on each entry to the call or block (also see [6.8](#) on variable initialization). This is roughly equivalent to a C automatic variable.

Tasks and functions may be declared as **automatic**. Variables declared in an automatic task, function, or block are local in scope, default to the lifetime of the call or block and are initialized on each entry to the call or block (also see [6.8](#) on variable initialization). An automatic block is one in which declarations are automatic by default. Specific variables within an automatic task, function, or block can be explicitly declared as static. Such variables have a static lifetime. This is roughly equivalent to C static variables declared within a function.

The lifetime of a fork-join block (see [9.3.2](#)) shall encompass the execution of all processes spawned by the block. The lifetime of a scope enclosing any fork-join block includes the lifetime of the fork-join block.

A variable declaration shall precede any simple reference (non-hierarchical) to that variable. Variable declarations shall precede any statements within a procedural block. Variables may also be declared in unnamed blocks. These variables are visible to the unnamed block and any nested blocks below it. Hierarchical references shall not be used to access these variables by name.

```
module msl;
  int st0;           // static
  initial begin
    int st1;        // static
    static int st2; // static
    automatic int auto1; // automatic
  end
  task automatic t1();
    int auto2;      // automatic
    static int st3; // static
```

```

    automatic int auto3;    // automatic
endtask
endmodule

```

Variables declared in a static task, function, or procedural block default to a static lifetime and a local scope. However, an explicit **static** keyword shall be required when an initialization value is specified as part of a static variable's declaration to indicate the user's intent of executing that initialization only once at the beginning of simulation. The **static** keyword shall be optional where it would not be legal to declare the variables as automatic. For example:

```

module top_legal;
    int svar1 = 1;                // static keyword optional
    initial begin
        for (int i=0; i<3; i++) begin
            automatic int loop3 = 0;    // executes every loop
            for (int j=0; j<3; j++) begin
                loop3++;
                $display(loop3);
            end
        end // prints 1 2 3 1 2 3 1 2 3
        for (int i=0; i<3; i++) begin
            static int loop2 = 0;    // executes once before time 0
            for (int j=0; j<3; j++) begin
                loop2++;
                $display(loop2);
            end
        end // prints 1 2 3 4 5 6 7 8 9
    end
endmodule : top_legal

module top_illegal;                // should not compile
    initial begin
        int svar2 = 2;                // static/automatic needed to show intent
        for (int i=0; i<3; i++) begin
            int loop3 = 0;            // illegal statement
            for (int i=0; i<3; i++) begin
                loop3++;
                $display(loop3);
            end
        end
    end
endmodule : top_illegal

```

An optional qualifier can be used to specify the default lifetime of all variables declared in a task, function, or block defined within a module, interface, package, or program. The lifetime qualifier is **automatic** or **static**. The default lifetime is **static**.

```

program automatic test ;
    int i;                            // not within a procedural block - static
    task t ( int a );                // arguments and variables in t are automatic
    ...                               // unless explicitly declared static
endtask
endprogram

```

It is permissible to hierarchically reference any static variable unless the variable is declared inside an unnamed block. This includes static variables declared inside automatic tasks and functions.

Class methods (see [Clause 8](#)) and declared `for` loop variables (see [12.7.1](#)) are by default automatic, regardless of the lifetime attribute of the scope in which they are declared.

Automatic variables and members or elements of dynamic variables—class properties and dynamically sized variables—shall not be written with nonblocking, continuous, or procedural continuous assignments. References to automatic variables and elements or members of dynamic variables shall be limited to procedural blocks.

See also [Clause 13](#) on tasks and functions.

6.22 Type compatibility

Some constructs and operations require a certain level of type compatibility for their operands to be legal. There are five levels of type compatibility, formally defined here: matching, equivalent, assignment compatible, cast compatible, and nonequivalent.

SystemVerilog does not require a category for identical types to be defined here because there is no construct in the SystemVerilog language that requires it. For example, as defined below, `int` can be interchanged with `bit signed [31:0]` wherever it is syntactically legal to do so. Users can define their own level of type identity by using the `$typename` system function (see [20.6.1](#)) or through use of the PLI.

The scope of a data type identifier shall include the hierarchical instance scope. In other words, each instance with a user-defined type declared inside the instance creates a unique type. To have type matching or equivalence among multiple instances of the same module, interface, program, or checker, a class, `enum`, unpacked structure, or unpacked union type must be declared at a higher level in the compilation-unit scope than the declaration of the module, interface, program, or checker, or imported from a package. For type matching, this is true even for packed structure and packed union types.

6.22.1 Matching types

Two data types shall be defined as *matching data types* using the following inductive definition. If two data types do not match using the following definition, then they shall be defined to be nonmatching.

- a) Any built-in type matches every other occurrence of itself, in every scope.
- b) A simple `typedef` or type parameter override that renames a built-in or user-defined type matches that built-in or user-defined type within the scope of the type identifier.

```
typedef bit node;          // 'bit' and 'node' are matching types
typedef type1 type2;      // 'type1' and 'type2' are matching types
```

- c) An anonymous `enum`, `struct`, or `union` type matches itself among data objects declared within the same declaration statement and no other data types.

```
struct packed {int A; int B;} AB1, AB2; // AB1, AB2 have matching types
struct packed {int A; int B;} AB3;     // the type of AB3 does not match
                                        // the type of AB1
```

- d) A `typedef` for an `enum`, `struct`, `union`, or `class` matches itself and the type of data objects declared using that data type within the scope of the data type identifier.

```
typedef struct packed {int A; int B;} AB_t;
AB_t AB1; AB_t AB2; // AB1 and AB2 have matching types

typedef struct packed {int A; int B;} otherAB_t;
```

```
otherAB_t AB3;    // the type of AB3 does not match the type of AB1 or AB2
```

- e) A simple bit vector type that does not have a predefined width and one that does have a predefined width match if both are 2-state or both are 4-state, both are signed or both are unsigned, both have the same width, and the range of the simple bit vector type without a predefined width is [width-1:0].

```
typedef bit signed [7:0] BYTE;    // matches the byte type
typedef bit signed [0:7] ETYB;   // does not match the byte type
```

- f) Two array types match if they are both packed or both unpacked, are the same kind of array (fixed-size, dynamic, associative, or queue), have matching index types (for associative arrays), and have matching element types. Fixed-size arrays shall also have the same left and right range bounds. Note that the element type of a multidimensional array is itself an array type.

```
typedef byte MEM_BYTES [256];
typedef bit signed [7:0] MY_MEM_BYTES [256];    // MY_MEM_BYTES matches
                                                // MEM_BYTES

typedef logic [1:0] [3:0] NIBBLES;
typedef logic [7:0] MY_BYTE; // MY_BYTE and NIBBLES are not matching types

typedef logic MD_ARY [] [2:0];
typedef logic MD_ARY_TOO [] [0:2]; // Does not match MD_ARY
```

- g) Explicitly adding **signed** or **unsigned** modifiers to a type that does not change its default signing creates a type that matches the type without the explicit signing specification.

```
typedef byte signed MY_CHAR; // MY_CHAR matches the byte type
```

- h) A **typedef** for an **enum**, **struct**, **union**, or **class** type declared in a package always matches itself, regardless of the scope into which the type is imported.

6.22.2 Equivalent types

Two data types shall be defined as *equivalent data types* using the following inductive definition. If the two data types are not defined as equivalent using the following definition, then they shall be defined to be nonequivalent.

- a) If two types match, they are equivalent.
- b) An anonymous **enum**, unpacked **struct**, or unpacked **union** type is equivalent to itself among data objects declared within the same declaration statement and no other data types.

```
struct {int A; int B;} AB1, AB2;    // AB1, AB2 have equivalent types
struct {int A; int B;} AB3;        // AB3 is not type equivalent to AB1
```

- c) Packed arrays, packed structures, packed unions, and built-in integral types are equivalent if they contain the same number of total bits, are either all 2-state or all 4-state, and are either all signed or all unsigned.

NOTE—If any bit of a packed structure or union is 4-state, the entire structure or union is considered 4-state.

```
typedef bit signed [7:0] BYTE;    // equivalent to the byte type
typedef struct packed signed {bit[3:0] a, b;} uint8;
                                                // equivalent to the byte type
```

- d) Unpacked fixed-size array types are equivalent if they have equivalent element types and equal size; the actual range bounds may differ. Note that the element type of a multidimensional array is itself an array type.

```

bit [9:0] A [0:5];
bit [1:10] B [6];
typedef bit [10:1] uint10;
uint10 C [6:1];           // A, B and C have equivalent types
typedef int anint [0:0]; // anint is not type equivalent to int

```

- e) Dynamic array, associative array and queue types are equivalent if they are the same kind of array (dynamic, associative, or queue), have equivalent index types (for associative arrays), and have equivalent element types.

The following example is assumed to be within one compilation unit, although the package declaration need not be in the same unit:

```

package p1;
  typedef struct {int A;} t_1;
endpackage

typedef struct {int A;} t_2;

module sub();
  import p1::t_1;
  parameter type t_3 = int;
  parameter type t_4 = int;
  typedef struct {int A;} t_5;
  t_1 v1; t_2 v2; t_3 v3; t_4 v4; t_5 v5;
endmodule

module top();
  typedef struct {int A;} t_6;
  sub #(.t_3(t_6)) s1 ();
  sub #(.t_3(t_6)) s2 ();

  initial begin
    s1.v1 = s2.v1; // legal - both types from package p1 (rule 8)
    s1.v2 = s2.v2; // legal - both types from $unit (rule 4)
    s1.v3 = s2.v3; // legal - both types from top (rule 2)
    s1.v4 = s2.v4; // legal - both types are int (rule 1)
    s1.v5 = s2.v5; // illegal - types from s1 and s2 (rule 4)
  end
endmodule

```

6.22.3 Assignment compatible

All equivalent types, and all nonequivalent types that have implicit casting rules defined between them, are *assignment-compatible types*. For example, all integral types are assignment compatible. Conversion between assignment-compatible types can involve loss of data by truncation or rounding.

Unpacked arrays are assignment compatible with certain other arrays that are not of equivalent type. Assignment compatibility of unpacked arrays is discussed in detail in [7.6](#).

Compatibility can be in one direction only. For example, an **enum** can be converted to an integral type without a cast, but not the other way around. Implicit casting rules are defined in [6.24](#).

6.22.4 Cast compatible

All assignment-compatible types, plus all nonequivalent types that have defined explicit casting rules, are *cast-compatible types*. For example, an integral type requires a cast to be assigned to an **enum**.

Explicit casting rules are defined in [6.24](#).

6.22.5 Type incompatible

Type incompatible includes all the remaining nonequivalent types that have no defined implicit or explicit casting rules. Class handles and chandles are type incompatible with all other types.

6.23 Type operator

The **type** operator provides a way to refer to the data type of an expression. A type reference can be used like a type name or local type parameter, for example, in casts, data object declarations, and type parameter assignments and overrides. It can also be used in equality/inequality and case equality/inequality comparisons with other type references, and such comparisons are considered to be constant expressions (see [11.2.1](#)). When a type reference is used in a net declaration, it shall be preceded by a net type keyword; and when it is used in a variable declaration, it shall be preceded by the **var** keyword.

```
var type (a+b) c, d;

c = type (i+3) ' (v[15:0]);
```

The **type** operator applied to an expression shall represent the self-determined result type of that expression. The expression shall not be evaluated and shall not contain any hierarchical references or references to elements of dynamic objects.

The type operator can also be applied to a data type.

```
localparam type T = type (bit[12:0]);
```

When a type reference is used in an equality/inequality or case equality/inequality comparison, it shall only be compared with another type reference. Two type references shall be considered equal in such comparisons if, and only if, the types to which they refer match (see [6.22.1](#)).

```
bit [12:0] A_bus, B_bus;
parameter type bus_t = type (A_bus);
generate
  case (type (bus_t))
    type (bit[12:0]): addfixed_int # (bus_t) (A_bus, B_bus);
    type (real): add_float # (type (A_bus)) (A_bus, B_bus);
  endcase
endgenerate
```

6.24 Casting

6.24.1 Cast operator

A data type can be changed by using a cast (') operation. The syntax for cast operations is shown in [Syntax 6-6](#).

```
constant_cast ::= // from A.8.4
    casting_type ' ( constant_expression )
cast ::=
    casting_type ' ( expression )
casting_type ::= simple_type | constant_primary | signing | string | const // from A.2.2.1
simple_type ::= integer_type | non_integer_type | ps_type_identifier | ps_parameter_identifier
```

Syntax 6-6—Casting (excerpt from [Annex A](#))

In a static cast, the expression to be cast shall be enclosed in parentheses that are prefixed with the casting type and an apostrophe. If the expression is assignment compatible with the casting type, then the cast shall return the value that a variable of the casting type would hold after being assigned the expression. If the expression is not assignment compatible with the casting type, then if the casting type is an enumerated type, the behavior shall be as described as in [6.19.4](#), and if the casting type is a bit-stream type, the behavior shall be as described in [6.24.3](#).

```
int'(2.0 * 3.0)
shortint'({8'hFA,8'hCE})
```

Thus, in the following example, if expressions `expr_1` and `expr_2` are assignment compatible with data types `cast_t1` and `cast_t2`, respectively, then

```
A = cast_t1'(expr_1) + cast_t2'(expr_2);
```

is the same as

```
cast_t1 temp1;
cast_t2 temp2;

temp1 = expr_1;
temp2 = expr_2;
A = temp1 + temp2;
```

Thus, an implicit cast (e.g., `temp1 = expr1`), if defined, gives the same results as the corresponding explicit cast (`cast_t1'(expr1)`).

If the casting type is a constant expression with a positive integral value, the expression in parentheses shall be padded or truncated to the size specified. It shall be an error if the size specified is zero or negative.

Examples:

```
17'(x - 2)

parameter P = 16;
(P+1)'(x - 2)
```

The signedness can also be changed.

signed' (x)

The expression inside the cast shall be an integral value when changing the size or signing.

When changing the size, the cast shall return the value that a packed array type with a single $[n-1:0]$ dimension would hold after being assigned the expression, where n is the cast size. The signedness shall pass through unchanged, i.e., the signedness of the result shall be the self-determined signedness of the expression inside the cast. The array elements shall be of type **bit** if the expression inside the cast is 2-state, otherwise they shall be of type **logic**.

When changing the signing, the cast shall return the value that a packed array type with a single $[n-1:0]$ dimension would hold after being assigned the expression, where n is the number of bits in the expression to be cast ($\$bits(expression)$). The signedness of the result shall be the signedness specified by the cast type. The array elements shall be of type **bit** if the expression inside the cast is 2-state; otherwise, they shall be of type **logic**.

NOTE—The $\$signed()$ and $\$unsigned()$ system functions (see [11.7](#)) return the same results as **signed'** () and **unsigned'** (), respectively.

Examples:

```
logic [7:0] regA;
logic signed [7:0] regS;

regA = unsigned'(-4); // regA = 8'b11111100
regS = signed'(4'b1100); // regS = -4
```

An expression may be changed to a constant with a **const** cast.

const' (x)

When casting an expression as a constant, the type of the expression to be cast shall pass through unchanged. The only effect is to treat the value as though it had been used to define a **const** variable of the type of the expression.

When casting to a predefined type, the prefix of the cast shall be the predefined type keyword. When casting to a user-defined type, the prefix of the cast shall be the user-defined type identifier.

When a **shortreal** is converted to an **int** or to 32 bits using either casting or assignment, its value is rounded (see [6.12](#)). Therefore, the conversion can lose information. To convert a **shortreal** to its underlying bit representation without a loss of information, use $\$shortrealtobits$ as defined in [20.5](#). To convert from the bit representation of a shortreal value into a **shortreal**, use $\$bitstoshortreal$ as defined in [20.5](#).

Structures can be converted to bits preserving the bit pattern. In other words, they can be converted back to the same value without any loss of information. When unpacked data are converted to the packed representation, the order of the data in the packed representation is such that the first field in the structure occupies the MSBs. The effect is the same as a concatenation of the data items (**struct** fields or array elements) in order. The type of the elements in an unpacked structure or array shall be valid for a packed representation in order to be cast to any other type, whether packed or unpacked.

An explicit cast between packed types is not required because they are implicitly cast as integral values, but a cast can be used by tools to perform stronger type checking.

The following example demonstrates how `$bits` can be used to obtain the size of a structure in bits (the `$bits` system function is discussed in [20.6.2](#)), which facilitates conversion of the structure into a packed array:

```
typedef struct {
    bit isfloat;
    union { int i; shortreal f; } n; // anonymous type
} tagged_st; // named structure

typedef bit [$bits(tagged_st) - 1 : 0] tagbits; // tagged_st defined above

tagged_st a [7:0]; // unpacked array of structures

tagbits t = tagbits'(a[3]); // convert structure to array of bits
a[4] = tagged_st'(t); // convert array of bits back to structure
```

Note that the `bit` data type loses `x` values. If these are to be preserved, the `logic` type should be used instead.

The size of a union in bits is the size of its largest member. The size of a `logic` in bits is 1.

The functions `$itor`, `$rtoi`, `$bitstoreal`, `$realtobits`, `$signed`, and `$unsigned` can also be used to perform type conversions (see [Clause 20](#)).

6.24.2 \$cast dynamic casting

The `$cast` system task can be used to assign values to variables that might not ordinarily be valid because of differing data type. `$cast` can be called as either a task or a function.

The syntax for `$cast` is as follows:

```
function int $cast( singular dest_var, singular source_exp );
```

or

```
task $cast( singular dest_var, singular source_exp );
```

The `dest_var` is the variable to which the assignment is made.

The `source_exp` is the expression that is to be assigned to the destination variable.

Use of `$cast` as either a task or a function determines how invalid assignments are handled.

When called as a task, `$cast` attempts to assign the source expression to the destination variable. If the assignment is invalid, a run-time error occurs, and the destination variable is left unchanged.

When called as a function, `$cast` attempts to assign the source expression to the destination variable and returns 1 if the cast is legal. If the cast fails, the function does not make the assignment and returns 0. When called as a function, no run-time error occurs, and the destination variable is left unchanged.

It is important to note that `$cast` performs a run-time check. No type checking is done by the compiler, except to check that the destination variable and source expression are singulars.

For example:

```
typedef enum { red, green, blue, yellow, white, black } Colors;
Colors col;
$cast( col, 2 + 3 );
```

This example assigns the expression (5 => black) to the enumerated type. Without `$cast` or a static compile-time cast operation, this type of assignment is illegal.

The following example shows how to use the `$cast` to check whether an assignment will succeed:

```
if ( ! $cast( col, 2 + 8 ) ) // 10: invalid cast
    $display( "Error in cast" );
```

Alternatively, the preceding examples can be cast using a static cast operation. For example:

```
col = Colors'(2 + 3);
```

However, this is a compile-time cast, i.e, a coercion that always succeeds at run time and does not provide for error checking or warn if the expression lies outside the enumeration values.

Allowing both types of casts gives full control to the user. If users know that certain expressions assigned to an enumerated variable lie within the enumeration values, the faster static compile-time cast can be used. If users need to check if an expression lies within the enumeration values, it is not necessary to write a lengthy case statement manually. The compiler automatically provides that functionality via the `$cast` function. By providing both types of casts, SystemVerilog enables users to balance the trade-offs of performance and checking associated with each cast type.

NOTE—`$cast` is similar to the `dynamic_cast` function available in C++. However, `$cast` allows users to check whether the operation will succeed, whereas `dynamic_cast` always raises a C++ exception.

6.24.3 Bit-stream casting

Type casting can also be applied to unpacked arrays and structs. It is thus possible to convert freely between bit-stream types using explicit casts. Types that can be packed into a stream of bits are called *bit-stream types*. A bit-stream type is a type consisting of the following:

- Any integral, packed, or string type
- Unpacked arrays, structures, or classes of the above types
- Dynamically sized arrays (dynamic, associative, or queues) of any of the above types

This definition is recursive so that, for example, a structure containing a queue of `int` is a bit-stream type.

Assuming A is of bit-stream type `source_t` and B is of bit-stream type `dest_t`, it is legal to convert A into B by an explicit cast:

```
B = dest_t'(A);
```

The conversion from A of type `source_t` to B of type `dest_t` proceeds in two steps:

- a) Conversion from `source_t` to a generic packed value containing the same number of bits as `source_t`. If `source_t` contains any 4-state data, the entire packed value is 4-state; otherwise, it is 2-state.
- b) Conversion from the generic packed value to `dest_t`. If the generic packed value is a 4-state type and parts of `dest_t` designate 2-state types, then those parts in `dest_t` are assigned as if cast to a 2-state.

When a dynamic array, queue, or string type is converted to the packed representation, the item at index 0 occupies the MSBs. When an associative array is converted to the packed representation, items are packed in index-sorted order with the first indexed element occupying the MSBs. An associative array type or class shall be illegal as a destination type. A class handle with local or protected members shall be illegal as a source type except when the handle is the current instance **this** (see [8.10](#) and [8.17](#)).

Both `source_t` and `dest_t` can include one or more dynamically sized data in any position (for example, a structure containing a dynamic array followed by a queue of bytes). If the source type, `source_t`, includes dynamically sized variables, they are all included in the bit stream. If the destination type, `dest_t`, includes unbounded dynamically sized types, the conversion process is greedy: compute the size of the `source_t`, subtract the size of the fixed-size data items in the destination, and then adjust the size of the first dynamically sized item in the destination to the remaining size; any remaining dynamically sized items are left empty.

For the purposes of a bit-stream cast, a string type is considered a dynamic array of bytes.

Regardless of whether the destination type contains only fixed-size items or dynamically sized items, data are extracted into the destination in left-to-right order. It is thus legal to fill a dynamically sized item with data extracted from the middle of the packed representation.

If both `source_t` and `dest_t` are fixed-size types of different sizes and either type is unpacked, then a cast generates a compile-time error. If `source_t` or `dest_t` contain dynamically sized types, then a difference in their sizes will issue an error either at compile time or at run time, as soon as it is possible to determine the size mismatch. For example:

```
// Illegal conversion from 24-bit struct to 32 bit int - compile time error
struct {bit[7:0] a; shortint b;} a;
int b = int'(a);

// Illegal conversion from 20-bit struct to int (32 bits) - run time error
struct {bit a[$]; shortint b;} a = {{1,2,3,4}, 67};
int b = int'(a);

// Illegal conversion from int (32 bits) to struct dest_t (25 or 33 bits),
// compile time error
typedef struct {byte a[$]; bit b;} dest_t;
int a;
dest_t b = dest_t'(a);
```

Bit-stream casting can be used to convert between different aggregate types, such as two structure types, or a structure and an array or queue type. This conversion can be useful to model packet data transmission over serial communication streams. For example, the code below uses bit-stream casting to model a control packet transfer over a data stream:

```
typedef struct {
    shortint address;
    logic [3:0] code;
    byte command [2];
} Control;

typedef bit Bits [36:1];

Control p;
Bits stream[$];

p = ... // initialize control packet
```

```
stream.push_back(Bits'(p)); // append packet to unpacked queue of Bits

Bits b;
Control q;
stream.pop_front(b); // get packet (as Bits) from stream
q = Control'(b); // convert packet bits back to a Control packet
```

The following example uses bit-stream casting to model a data packet transfer over a byte stream:

```
typedef struct {
    byte length;
    shortint address;
    byte payload[];
    byte chksum;
} Packet;
```

The above type defines a generic data packet in which the size of the payload field is stored in the length field. Below is a function that randomly initializes the packet and computes the checksum.

```
function Packet genPkt();
    Packet p;

    void'( randomize( p.address, p.length, p.payload )
        with { p.length > 1 && p.payload.size == p.length; } );
    p.chksum = p.payload.xor();
    return p;
endfunction
```

The byte stream is modeled using a queue, and a bit-stream cast is used to send the packet over the stream.

```
typedef byte channel_type[$];
channel_type channel;
channel = {channel, channel_type'(genPkt())};
```

And the code to receive the packet:

```
Packet p;
int size;

size = channel[0] + 4;
p = Packet'( channel[0 : size - 1] ); // convert stream to Packet
channel = channel[ size : $ ]; // update the stream so it now
// lacks that packet
```

7. Aggregate data types

7.1 General

This clause describes the following:

- Structure definitions and usage
- Union definitions and usage
- Packed arrays, unpacked arrays, dynamic arrays, associative arrays, and queues
- Array query and manipulation methods

7.2 Structures

A *structure* represents a collection of data types that can be referenced as a whole, or the individual data types that make up the structure can be referenced by name. By default, structures are unpacked, meaning that there is an implementation-dependent packing of the data types. Unpacked structures can contain any data type.

Structure declarations follow the C syntax, but without the optional structure tags before the '{'. The syntax for structure declarations is shown in [Syntax 7-1](#).

```

data_type ::= // from A.2.2.1
...
| struct_union [ packed [ signing ] ] { struct_union_member { struct_union_member } }
  { packed_dimension }12
struct_union_member16 ::=
  { attribute_instance } [random_qualifier] data_type_or_void list_of_variable_decl_assignments ;
data_type_or_void ::= data_type | void
struct_union ::= struct | union [ tagged ]

```

¹²) When a packed dimension is used with the **struct** or **union** keyword, the **packed** keyword shall also be used.

¹⁶) It shall be legal to declare a **void** struct_union_member only within tagged unions.

Syntax 7-1—Structure declaration syntax (excerpt from [Annex A](#))

Examples of declaring structures are as follows:

```

struct { bit [7:0] opcode; bit [23:0] addr; }IR; // anonymous structure
// defines variable IR
IR.opcode = 1; // set field in IR.

typedef struct {
    bit [7:0] opcode;
    bit [23:0] addr;
} instruction; // named structure type
instruction IR; // define variable

```

7.2.1 Packed structures

A packed structure is a mechanism for subdividing a vector into subfields, which can be conveniently accessed as members. Consequently, a packed structure consists of bit fields, which are packed together in memory without gaps. An unpacked structure has an implementation-dependent packing, normally matching the C compiler. A packed structure differs from an unpacked structure in that, when a packed structure appears as a primary, it shall be treated as a single vector.

A packed structure can be used as a whole with arithmetic and logical operators. The first member specified is the most significant and subsequent members follow in decreasing significance. The structures are declared using the **packed** keyword, which can be followed by the **signed** or **unsigned** keyword, according to the desired arithmetic behavior. The default is unsigned.

```
struct packed signed {
    int a;
    shortint b;
    byte c;
    bit [7:0] d;
} pack1; // signed, 2-state

struct packed unsigned {
    time a;
    integer b;
    logic [31:0] c;
} pack2; // unsigned, 4-state
```

The signing of unpacked structures is not allowed. The following declaration would be considered illegal:

```
typedef struct signed {
    int f1 ;
    logic f2 ;
} sIllegalSignedUnpackedStructType; // illegal declaration
```

If all data types within a packed structure are 2-state, the structure as a whole is treated as a 2-state vector.

If any data type within a packed structure is 4-state, the structure as a whole is treated as a 4-state vector. If there are also 2-state members in the structure, there is an implicit conversion from 4-state to 2-state when reading those members and from 2-state to 4-state when writing them.

One or more bits of a packed structure can be selected as if it were a packed array with the range $[n-1:0]$:

```
pack1 [15:8] // c
```

Only packed data types and the integer data types summarized in [Table 6-8](#) (see [6.11](#)) shall be legal in packed structures.

A packed structure can be used with a **typedef**.

```
typedef struct packed { // default unsigned
    bit [3:0] GFC;
    bit [7:0] VPI;
    bit [11:0] VCI;
    bit CLP;
    bit [3:0] PT ;
    bit [7:0] HEC;
    bit [47:0] [7:0] Payload;
    bit [2:0] filler;
} s_atmcell;
```

7.2.2 Assigning to structures

A structure can be assigned as a whole and passed to or from a subroutine as a whole.

Members of a structure data type can be assigned individual default member values by using an initial assignment with the declaration of each member. The assigned expression shall be a constant expression.

An example of initializing members of a structure type is as follows:

```
typedef struct {
    int addr = 1 + constant;
    int crc;
    byte data [4] = '{4{1}}';
} packet1;
```

The structure can then be instantiated.

```
packet1 p1;    // initialization defined by the typedef.
              // p1.crc will use the default value for an int
```

If an explicit initial value expression is used with the declaration of a variable, the initial assignment expression within the structure data type shall be ignored. Subclause [5.10](#) discusses assigning initial values to a structure. For example:

```
packet1 pi = '{1,2,'{2,3,4,5}}'; //suppresses the typedef initialization
```

Members of unpacked structures containing a union as well as members of packed structures shall not be assigned individual default member values.

The initial assignment expression within a data type shall be ignored when using a data type to declare a net (see [6.7](#)).

7.3 Unions

A *union* is a data type that represents a single piece of storage which can be accessed using one of the named member data types. Only one of the data types in the union can be used at a time. By default, a union is unpacked, meaning there is no required representation for how members of the union are stored. Dynamic types and handle types can only be used in tagged unions.

The syntax for union declarations is shown in [Syntax 7-2](#).

```
data_type ::= // from A.2.2.1
...
| struct_union [ packed [ signing ] ] { struct_union_member { struct_union_member } }
  { packed_dimension }12
struct_union_member16 ::=
  { attribute_instance } [random_qualifier] data_type_or_void list_of_variable_decl_assignments ;
data_type_or_void ::= data_type | void
struct_union ::= struct | union [ tagged ]
```

¹²) When a packed dimension is used with the **struct** or **union** keyword, the **packed** keyword shall also be used.

¹⁶) It shall be legal to declare a **void** struct_union_member only within tagged unions.

Examples:

```
typedef union { int i; shortreal f; } num;           // named union type
num n;
n.f = 0.0; // set n in floating point format

typedef struct {
    bit isfloat;
    union { int i; shortreal f; } n;           // anonymous union type
} tagged_st;                                     // named structure
```

If no initial value is specified in the declaration of a variable of an unpacked union type, then the variable shall be initialized to the default initial value for variables of the type of the first member in declaration order of the union type.

One special provision exists in order to simplify the use of unpacked unions: if an unpacked union contains several unpacked structures that share a common initial sequence and if the unpacked union object currently contains one of these structures, it is permitted to inspect the common initial part of any of them anywhere that a declaration of the complete type of the union is visible. Two structures share a common initial sequence if corresponding members have equivalent types for a sequence of one or more initial members.

7.3.1 Packed unions

Packed unions shall only contain members that are of integral data types. The members of a packed, untagged union shall all be the same size (in contrast to an unpacked union or a packed, tagged union, where the members can be different sizes). Thus, a union member that was written as another member can be read back. A packed union can also be used as a whole with arithmetic and logical operators, and its behavior is determined by the **signed** or **unsigned** keyword, the latter being the default. One or more bits of a packed union can be selected as if it were a packed array with the range $[n-1:0]$.

Only packed data types and the integer data types summarized in [Table 6-8](#) (see [6.11](#)) shall be legal in packed unions.

If a packed union contains a 2-state member and a 4-state member, the entire union is 4-state. There is an implicit conversion from 4-state to 2-state when reading and from 2-state to 4-state when writing the 2-state member.

For example, a union can be accessible with different access widths:

```
typedef union packed { // default unsigned
    s_atmcell acell;
    bit [423:0] bit_slice;
    bit [52:0][7:0] byte_slice;
} u_atmcell;

u_atmcell u1;
byte b; bit [3:0] nib;
b = u1.bit_slice[415:408]; // same as b = u1.byte_slice[51];
nib = u1.bit_slice [423:420]; // same as nib = u1.acell.GFC;
```

With packed unions, writing one member and reading another is independent of the byte ordering of the machine, unlike an unpacked union of unpacked structures, which are C-compatible and have members in ascending address order.

7.3.2 Tagged unions

The qualifier **tagged** in a union declares it as a *tagged union*, which is a type-checked union. An ordinary (untagged) union can be updated using a value of one member type and read as a value of another member type, which is a potential type loophole. A tagged union stores both the member value and a *tag*, i.e., additional bits representing the current member name. The tag and value can only be updated together consistently using a statically type-checked tagged union expression (see [11.9](#)). The member value can only be read with a type that is consistent with the current tag value (i.e., member name). Thus, it is impossible to store a value of one type and (mis)interpret the bits as another type.

Dynamic types and *chandle* types shall not be used in untagged unions, but may be used in tagged unions.

Members of tagged unions can be referenced as tagged expressions. See [11.9](#).

In addition to type safety, the use of member names as tags also makes code simpler and smaller than code that has to track unions with explicit tags. Tagged unions can also be used with pattern matching (see [12.6](#)), which improves readability even further.

In tagged unions, members can be declared with type **void**, when all the information is in the tag itself, as in the following example of an integer together with a valid bit:

```
typedef union tagged {
    void Invalid;
    int Valid;
} VInt;
```

A value of `VInt` type is either `Invalid` (and contains nothing) or `Valid` (and contains an **int**). Subclause [11.9](#) describes how to construct values of this type and also describes how it is impossible to read an integer out of a `VInt` value that currently has the `Invalid` tag.

For example:

```
typedef union tagged {
    struct {
        bit [4:0] reg1, reg2, regd;
    } Add;
    union tagged {
        bit [9:0] JmpU;
        struct {
            bit [1:0] cc;
            bit [9:0] addr;
        } JmpC;
    } Jmp;
} Instr;
```

A value of `Instr` type is either an `Add` instruction, in which case it contains three 5-bit register fields, or it is a `Jmp` instruction. In the latter case, it is either an unconditional jump, in which case it contains a 10-bit destination address, or it is a conditional jump, in which case it contains a 2-bit condition-code register field and a 10-bit destination address. Subclause [11.9](#) describes how to construct values of `Instr` type and describes how, in order to read the `cc` field, for example, the instruction must have opcode `Jmp` and sub-opcode `JmpC`.

When the **packed** qualifier is used on a tagged union, all the members shall have packed types, but they do not have to be of the same size. The (standard) representation for a packed tagged union is the following:

- The size is always equal to the number of bits needed to represent the tag plus the maximum of the sizes of the members.

- The size of the tag is the minimum number of bits needed to code for all the member names (e.g., five to eight members would need 3 tag bits).
- The tag bits are always left-justified (i.e., towards the MSBs).
- For each member, the member bits are always right-justified [i.e., towards the least significant bits (LSBs)].
- The bits between the tag bits and the member bits are undefined. In the extreme case of a void member, only the tag is significant and all the remaining bits are undefined.

The representation scheme is applied recursively to any nested tagged unions.

For example, if the `VInt` type definition had the `packed` qualifier, `Invalid` and `Valid` values will have the layouts shown in [Figure 7-1](#), respectively.

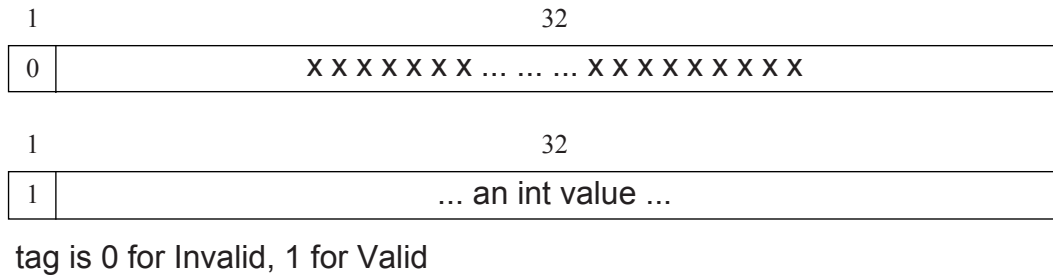
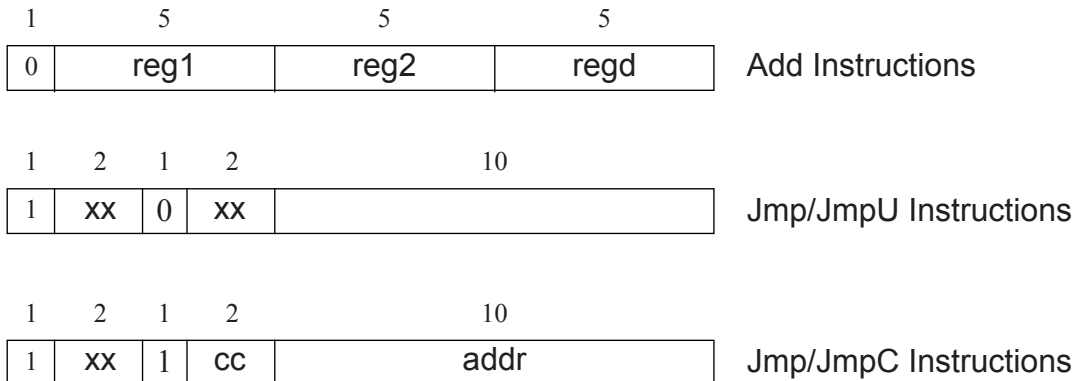

Figure 7-1—VInt type with packed qualifier

For example, if the `Instr` type had the `packed` qualifier, its values will have the layouts shown in [Figure 7-2](#).



Outer tag is 0 for Add, 1 for Jmp
 Inner tag is 0 for JmpU, 1 for JmpC

Figure 7-2—Instr type with packed qualifier

7.4 Packed and unpacked arrays

SystemVerilog supports both packed arrays and unpacked arrays of data. The term *packed array* is used to refer to the dimensions declared before the data identifier name. The term *unpacked array* is used to refer to the dimensions declared after the data identifier name.

```

bit [7:0] c1;          // packed array of scalar bit types
real u [7:0];        // unpacked array of real types

```

A one-dimensional packed array is often referred to as a *vector* (see [6.9](#)). Multidimensional packed arrays are also allowed.

Unpacked arrays may be fixed-size arrays (see [7.4.2](#)), dynamic arrays (see [7.5](#)), associative arrays (see [7.8](#)), or queues (see [7.10](#)). Unpacked arrays are formed from any data type, including other packed or unpacked arrays (see [7.4.5](#)).

7.4.1 Packed arrays

A packed array is a mechanism for subdividing a vector into subfields, which can be conveniently accessed as array elements. Consequently, a packed array is guaranteed to be represented as a contiguous set of bits. An unpacked array may or may not be so represented. A packed array differs from an unpacked array in that, when a packed array appears as a primary, it is treated as a single vector.

If a packed array is declared as signed, then the array viewed as a single vector shall be signed. The individual elements of the array are unsigned unless they are of a named type declared as signed. A part-select of a packed array shall be unsigned.

Packed arrays allow arbitrary length integer types; therefore, a 48-bit integer can be made up of 48 bits. These integers can then be used for 48-bit arithmetic. The maximum size of a packed array can be limited, but shall be at least 65 536 (2^{16}) bits.

Packed arrays can be made of only the single bit data types (**bit**, **logic**, **reg**), enumerated types, and recursively other packed arrays and packed structures.

Integer types with predefined widths shall not have packed array dimensions declared. These types are **byte**, **shortint**, **int**, **longint**, **integer**, and **time**. Although an integer type with a predefined width n is not a packed array, it matches (see [6.22](#)), and can be selected from as if it were, a packed array type with a single $[n-1:0]$ dimension.

```

byte c2;          // same as bit signed [7:0] c2;
integer i1;      // same as logic signed [31:0] i1;

```

7.4.2 Unpacked arrays

Unpacked arrays can be made of any data type. Arrays whose elements are themselves arrays are declared as multidimensional arrays (see [7.4.5](#)). Unpacked arrays shall be declared by specifying the element address range(s) after the declared identifier.

Elements of net arrays can be used in the same fashion as a scalar or vector net. Net arrays are useful for connecting to ports of module instances inside loop generate constructs (see [27.4](#)).

Each fixed-size dimension shall be represented by an address range, such as $[1:1024]$, or a single positive number to specify the size of a fixed-size unpacked array, as in C. In other words, $[size]$ becomes the same as $[0:size-1]$.

The following examples declare equivalent size two-dimensional fixed-size arrays of **int** variables:

```

int Array[0:7][0:31]; // array declaration using ranges

int Array[8][32];     // array declaration using sizes

```

The expressions that specify an address range shall be constant integer expressions. The value of the constant expression can be a positive integer, a negative integer, or zero. It shall be illegal for them to contain any unknown (x) or high-impedance bits.

Implementations may limit the maximum size of an array, but they shall allow at least 16 777 216 (2^{24}) elements.

7.4.3 Operations on arrays

The following operations can be performed on all arrays, packed or unpacked. The examples provided with these rules assume that A and B are arrays of the same shape and type.

- Reading and writing the array, e.g., A = B
- Reading and writing a slice of the array, e.g., A[i:j] = B[i:j]
- Reading and writing a variable slice of the array, e.g., A[x+:c] = B[y+:c]
- Reading and writing an element of the array, e.g., A[i] = B[i]
- Equality operations on the array or slice of the array, e.g., A==B, A[i:j] != B[i:j]

The following operations can be performed on packed arrays, but not on unpacked arrays. The examples provided with these rules assume that A is an array.

- Assignment from an integer, e.g., A = 8'b11111111;
- Treatment as an integer in an expression, e.g., (A + 3)

If an unpacked array is declared as signed, then this applies to the individual elements of the array because the whole array cannot be viewed as a single vector.

See [7.6](#) for rules for assigning to packed and unpacked arrays.

7.4.4 Memories

A one-dimensional array with elements of types **reg**, **logic** or **bit** is also called a *memory*. Memory arrays can be used to model read-only memories (ROMs), random access memories (RAMs), and register files. An element of the packed dimension in the array is known as a memory *element* or *word*.

```

logic [7:0] mema [0:255]; // declares a memory array of 256 8-bit
                          // elements. The array indices are 0 to 255

mem_a[5] = 0;           // Write to word at address 5

data = mem_a[addr];    // Read word at address indexed by addr
  
```

7.4.5 Multidimensional arrays

A *multidimensional array* is an array of arrays. Multidimensional arrays can be declared by including multiple dimensions in a single declaration. The dimensions preceding the identifier set the packed dimensions. The dimensions following the identifier set the unpacked dimensions.

```

bit [3:0] [7:0] joe [1:10]; // 10 elements of 4 8-bit bytes
                             // (each element packed into 32 bits)
  
```

can be used as follows:

```

joe[9] = joe[8] + 1; // 4 byte add
joe[7][3:2] = joe[6][1:0]; // 2 byte copy
  
```

In a multidimensional declaration, the dimensions declared following the type and before the name ([3:0][7:0] in the preceding declaration) vary more rapidly than the dimensions following the name ([1:10] in the preceding declaration). When referenced, the packed dimensions ([3:0], [7:0]) follow the unpacked dimensions ([1:10]).

In a list of dimensions, the rightmost one varies most rapidly, as in C. However, a packed dimension varies more rapidly than an unpacked one.

```

bit [1:10] v1 [1:5];    // 1 to 10 varies most rapidly; compatible with
                        // memory arrays

bit v2 [1:5] [1:10];   // 1 to 10 varies most rapidly, compatible with C

bit [1:5] [1:10] v3 ;  // 1 to 10 varies most rapidly

bit [1:5] [1:6] v4 [1:7] [1:8]; // 1 to 6 varies most rapidly, followed by
                        // 1 to 5, then 1 to 8 and then 1 to 7

```

Multiple packed dimensions can also be defined in stages with **typedef**.

```

typedef bit [1:5] bsix;
bsix [1:10] v5; // 1 to 5 varies most rapidly

```

Multiple unpacked dimensions can also be defined in stages with **typedef**.

```

typedef bsix mem_type [0:3]; // array of four 'bsix' elements
mem_type ba [0:7];           // array of eight 'mem_type' elements

```

A *subarray* is an array that is an element of another array. As in the C language, subarrays are referenced by omitting indices for one or more array dimensions, always omitting the ones that vary most rapidly. Omitting indices for all the dimensions references the entire array.

```

int A[2][3][4], B[2][3][4], C[5][4];
...
A[0][2] = B[1][1]; // assign a subarray composed of four ints
A[1] = B[0];       // assign a subarray composed of three arrays of
                  // four ints each
A = B;             // assign an entire array
A[0][1] = C[4];    // assign compatible subarray of four ints

```

A comma-separated list of array declarations can be specified. All arrays in the list shall have the same data type and the same packed array dimensions.

```

bit [7:0] [31:0] v7 [1:5] [1:10], v8 [0:255]; // two arrays declared

```

7.4.6 Indexing and slicing of arrays

An expression can select part of a packed array, or any integer type, which is assumed to be numbered down to 0.

The term *part-select* refers to a selection of one or more contiguous bits of a single-dimension packed array.

```

logic [63:0] data;
logic [7:0] byte2;
byte2 = data[23:16]; // an 8-bit part-select from data

```

The term *slice* refers to a selection of one or more contiguous elements of an array.

NOTE—IEEE Std 1364-2005 only permitted a single element of an array to be selected.

A single element of a packed or unpacked array can be selected using an indexed name.

```
bit [3:0] [7:0] j; // j is a packed array
byte k;
k = j[2]; // select a single 8-bit element from j
```

One or more contiguous elements can be selected using a slice name. A slice name of a packed array is a packed array. A slice name of an unpacked array is an unpacked array.

```
bit signed [31:0] busA [7:0] ; // unpacked array of 8 32-bit vectors
int busB [1:0]; // unpacked array of 2 integers
busB = busA[7:6]; // select a 2-vector slice from busA
```

The size of the part-select or slice shall be constant, but the position can be variable.

```
int i = bitvec[j +: k]; // k must be constant.
int a[x:y], b[y:z], e;
a = {b[c -: d], e}; // d must be constant
```

Slices of an array can only apply to one dimension, but other dimensions can have single index values in an expression.

If an index expression is out of the address bounds or if any bit in the address is *x* or *z*, then the index shall be invalid. The result of reading from an array with an invalid index shall return the default uninitialized value for the array element type. Writing to an array with an invalid index shall perform no operation. Implementations may issue a warning if an invalid index occurs for a read or write operation of an array.

See [11.5.1](#) and [11.5.2](#) for more information on vector and array element selecting and slicing.

7.5 Dynamic arrays

A dynamic array is an unpacked array whose size can be set or changed at run time. The default size of an uninitialized dynamic array is zero. The size of a dynamic array is set by the **new** constructor or array assignment, described in [7.5.1](#) and [7.6](#) respectively. Dynamic arrays support all variable data types as element types, including arrays.

Dynamic array dimensions are denoted in the array declaration by []. Any unpacked dimension in an array declaration may be a dynamic array dimension.

For example:

```
bit [3:0] nibble[]; // Dynamic array of 4-bit vectors
integer mem[2][]; // Fixed-size unpacked array composed
// of 2 dynamic subarrays of integers
```

Note that in order for an identifier to represent a dynamic array, it must be declared with a dynamic array dimension as the leftmost unpacked dimension.

The **new**[] constructor is used to set or change the size of the array and initialize its elements (see [7.5.1](#)).

The **size()** built-in method returns the current size of the array (see [7.5.2](#)).

The **delete()** built-in method clears all the elements yielding an empty array (zero size) (see [7.5.3](#)).

7.5.1 New[]

The **new** constructor sets the size of a dynamic array and initializes its elements. It may appear in place of the right-hand side expression of variable declaration assignments and blocking procedural assignments when the left-hand side indicates a dynamic array.

```
blocking_assignment ::= //from A.6.2
...
| nonrange_variable_lvalue = dynamic_array_new
...
dynamic_array_new ::= new [ expression ] [ ( expression ) ] //from A.2.4
```

Syntax 7-3—Dynamic array new constructor syntax (excerpt from [Annex A](#))

[expression]:

The desired size of the dynamic array. The type of this operand is **longint**. It shall be an error if the value of this operand is negative. If this operand is zero, the array shall become empty.

(expression):

Optional. An array with which to initialize the dynamic array.

The **new** constructor follows the SystemVerilog precedence rules. Because both the square brackets [] and the parenthesis () have the same precedence, the arguments to the **new** constructor are evaluated left to right: [expression] first, and (expression) second.

Dynamic array declarations may include a declaration assignment with the **new** constructor as the right-hand side:

```
int arr1 [][2][3] = new [4]; // arr1 sized to length 4; elements are
                             // fixed-size arrays and so do not require
                             // initializing

int arr2 [][] = new [4];    // arr2 sized to length 4; dynamic subarrays
                             // remain unsized and uninitialized

int arr3 [1][2][] = new [4]; // Error - arr3 is not a dynamic array, though
                             // it contains dynamic subarrays
```

Dynamic arrays may be initialized in procedural contexts using the **new** constructor in blocking assignments:

```
int arr[2][][];
arr[0] = new [4]; // dynamic subarray arr[0] sized to length 4

arr[0][0] = new [2]; // legal, arr[0][n] created above for n = 0..3

arr[1][0] = new [2]; // illegal, arr[1] not initialized so arr[1][0] does
                    // not exist

arr[0][] = new [2]; // illegal, syntax error - dimension without
                    // subscript on left hand side

arr[0][1][1] = new[2]; // illegal, arr[0][1][1] is an int, not a dynamic
                       // array
```

In either case, if the **new** constructor call does not specify an initialization expression, the elements are initialized to the default value for their type.

The optional initialization expression is used to initialize the dynamic array. When present, it shall be an array that is assignment-compatible with the left-hand-side dynamic array.

```
int idest[], isrc[3] = {5, 6, 7};  
idest = new [3] (isrc); // set size and array element data values (5, 6, 7)
```

The size argument need not match the size of the initialization array. When the initialization array's size is greater, it is truncated to match the size argument; when it is smaller, the initialized array is padded with default values to attain the specified size.

```
int src[], dest1[], dest2[];  
src = new [3] ({2, 3, 4});  
dest1 = new[2] (src); // dest1's elements are {2, 3}.  
dest2 = new[4] (src); // dest2's elements are {2, 3, 4, 0}.
```

This behavior provides a mechanism for resizing a dynamic array while preserving its contents. An existing dynamic array can be resized by using it both as the left-hand side term and the initialization expression.

```
integer addr[]; // Declare the dynamic array.  
addr = new[100]; // Create a 100-element array.  
...  
// Double the array size, preserving previous values.  
// Preexisting references to elements of addr are outdated.  
addr = new[200] (addr);
```

Resizing or reinitializing a previously-initialized dynamic array using **new** is destructive; no preexisting array data is preserved (unless reinitialized with its old contents—see above), and all preexisting references to array elements become outdated.

7.5.2 Size()

The prototype for the `size()` method is as follows:

```
function int size();
```

The `size()` method returns the current size of a dynamic array or returns zero if the array has not been created.

```
int j = addr.size;  
addr = new[ addr.size() * 4 ] (addr); // quadruple addr array
```

The `size` dynamic array method is equivalent to `$size(addr, 1)` array query system function (see [20.7](#)).

7.5.3 Delete()

The prototype for the `delete()` method is as follows:

```
function void delete();
```

The `delete()` method empties the array, resulting in a zero-sized array.

```
int ab [] = new[ N ]; // create a temporary array of size N
```

```
// use ab
ab.delete;           // delete the array contents
$display( "%d", ab.size ); // prints 0
```

7.6 Array assignments

For the purposes of assignment, a packed array is treated as a vector. Any vector expression can be assigned to any packed array. The packed array bounds of the target packed array do not affect the assignment. A packed array cannot be directly assigned to an unpacked array without an explicit cast.

Associative arrays are assignment compatible only with associative arrays, as described in [7.9.9](#). A fixed-size unpacked array, dynamic array or queue, or a slice of such an array, shall be assignment compatible with any other such array or slice if all the following conditions are satisfied:

- The element types of source and target shall be equivalent.
- If the target is a fixed-size array or a slice, the source array shall have the same number of elements as the target.

Here *element* refers to elements of the slowest-varying array dimension. These elements may themselves be of some unpacked array type. Consequently, for two arrays to be assignment compatible it is necessary (but not sufficient) that they have the same number of unpacked dimensions. Assignment compatibility of unpacked arrays is a weaker condition than type equivalence because it does not require their slowest-varying dimensions to be of the same unpacked array kind (queue, dynamic or fixed-size). This weaker condition applies only to the slowest-varying dimension. Any faster-varying dimensions must meet the requirements for equivalence (see [6.22.2](#)) for the entire arrays to be assignment compatible.

Assignment shall be done by assigning each element of the source array to the corresponding element of the target array. Correspondence between elements is determined by the left-to-right order of elements in each array. For example, if array A is declared as `int A[7:0]` and array B is declared as `int B[1:8]`, the assignment `A = B;` will assign element B[1] to element A[7], and so on. If the target of the assignment is a queue or dynamic array, it shall be resized to have the same number of elements as the source expression and assignment shall then follow the same left-to-right element correspondence as described above.

```
int A[10:1];        // fixed-size array of 10 elements
int B[0:9];        // fixed-size array of 10 elements
int C[24:1];       // fixed-size array of 24 elements

A = B;             // ok. Compatible type and same size
A = C;             // type check error: different sizes
```

An array of wires can be assigned to an array of variables, and vice versa, if the source and target arrays' data types are assignment compatible.

```
logic [7:0] V1[10:1];
logic [7:0] V2[10];
wire [7:0] W[9:0];    // data type is logic [7:0] W[9:0]
assign W = V1;
initial #10 V2 = W;
```

When a dynamic array or queue is assigned to a fixed-size array, the size of the source array cannot be determined until run time. An attempt to copy a dynamic array or queue into a fixed-size array target having a different number of elements shall result in a run time error and no operation shall be performed. Example code showing assignment of a dynamic array to a fixed-size array follows.

```
int A[2][100:1];
```

```

int B[] = new[100];    // dynamic array of 100 elements
int C[] = new[8];     // dynamic array of 8 elements
int D [3][][];        // multidimensional array with dynamic subarrays
D[2] = new [2];       // initialize one of D's dynamic subarrays
D[2][0] = new [100];

A[1] = B;              // OK. Both are arrays of 100 ints
A[1] = C;              // type check error: different sizes (100 vs. 8 ints)
A = D[2];              // A[0:1][100:1] and subarray D[2][0:1][0:99] both
                       // comprise 2 subarrays of 100 ints

```

Examples showing assignment to a dynamic array are below. (See [7.5.1](#) for additional assignment examples involving the dynamic array **new** constructor).

```

int A[100:1];         // fixed-size array of 100 elements
int B[];              // empty dynamic array
int C[] = new[8];    // dynamic array of size 8

B = A;                // ok. B has 100 elements
B = C;                // ok. B has 8 elements

```

The last statement above is equivalent to:

```
B = new[ C.size ] (C);
```

Similarly, the source of an assignment can be a complex expression involving array slices or concatenations. For example:

```

string d[1:5] = '{ "a", "b", "c", "d", "e" }';
string p[];
p = { d[1:3], "hello", d[4:5] };

```

The preceding example creates the dynamic array `p` with contents "a", "b", "c", "hello", "d", "e".

7.7 Arrays as arguments to subroutines

Arrays can be passed as arguments to subroutines. The rules that govern array argument passing by value are the same as for array assignment (see [7.6](#)). When an array argument is passed by value, a copy of the array is passed to the called subroutine. This is true for all array types: fixed-size, dynamic, queue, or associative.

The rules that govern whether an array actual argument can be associated with a given formal argument are the same as the rules for whether a source array's values can be assigned to a destination array (see [7.6](#)). If a dimension of a formal is unsized (unsized dimensions can occur in dynamic arrays, queues, and formal arguments of import DPI functions), then it matches any size of the actual argument's corresponding dimension.

For example, the declaration

```
task fun(int a[3:1][3:1]);
```

declares task `fun` that takes one argument, a two-dimensional array with each dimension of size 3. A call to `fun` must pass a two-dimensional array and with the same dimension size 3 for all the dimensions. For example, given the above description for `fun`, consider the following actuals:

```

int b[3:1][3:1];     // OK: same type, dimension, and size

int b[1:3][0:2];     // OK: same type, dimension, & size (different ranges)

```

```
logic b[3:1][3:1]; // error: incompatible element type
event b[3:1][3:1]; // error: incompatible type
int b[3:1]; // error: incompatible number of dimensions
int b[3:1][4:1]; // error: incompatible size (3 vs. 4)
```

A subroutine that accepts a fixed-size array can also be passed a dynamic array or queue with compatible type and equal size.

For example, the declaration

```
task t ( string arr[4:1] );
```

declares a task that accepts one argument, an array of 4 strings. This task can accept the following actual arguments:

```
string b[4:1]; // OK: same type and size
string b[5:2]; // OK: same type and size (different range)
string b[] = new[4]; // OK: same type, number of dimensions, and
// dimension size; requires run-time check
```

A subroutine that accepts a dynamic array or queue can be passed a dynamic array, queue, or fixed-size array of a compatible type.

For example, the declaration

```
task t ( string arr[] );
```

declares a task that accepts one argument, a dynamic array of strings. This task can accept any one-dimensional unpacked array of strings or any one-dimensional dynamic array or queue of strings.

The rules that govern dynamic array and queue formal arguments also govern the behavior of unpacked dimensions of DPI open array formal arguments (see 7.6). DPI open arrays can also have a solitary unsized, packed dimension (see 34.5.6.1). A dynamic array or queue shall not be passed as an actual argument if the DPI formal argument has unsized dimensions and an output direction mode.

7.8 Associative arrays

Dynamic arrays are useful for dealing with contiguous collections of variables whose number changes dynamically. When the size of the collection is unknown or the data space is sparse, an associative array is a better option. Associative arrays do not have any storage allocated until it is used, and the index expression is not restricted to integral expressions, but can be of any type.

An associative array implements a lookup table of the elements of its declared type. The data type to be used as an index serves as the lookup key and imposes an ordering.

The syntax to declare an associative array is as follows:

```
data_type array_id [ index_type ];
```

where

`data_type` is the data type of the array elements. Can be any type allowed for fixed-size arrays.

`array_id` is the name of the array being declared.

`index_type` is the data-type to be used as an index or is `*`. If `*` is specified, then the array is indexed by any integral expression of arbitrary size. An index type restricts the indexing expressions to a particular type. It shall be illegal for `index_type` to declare a type.

Examples of associative array declarations are as follows:

```
integer i_array[*];           // associative array of integer (unspecified
                               // index)

bit [20:0] array_b[string]; // associative array of 21-bit vector,
                               // indexed by string

event ev_array[myClass];    // associative array of event indexed by class
                               // myClass
```

Array elements in associative arrays are allocated dynamically; an entry is created the first time it is written. The associative array maintains the entries that have been assigned values and their relative order according to the index data type. Associative array elements are unpacked. In other words, other than for copying or comparing arrays, an individual element must be selected out of the array before it can be used in most expressions.

7.8.1 Wildcard index type

For example:

```
int array_name [*];
```

Associative arrays that specify a wildcard index type have the following properties:

- The array may be indexed by any integral expression. Because the index expressions may be of different sizes, the same numerical value can have multiple representations, each of a different size. SystemVerilog resolves this ambiguity by removing the leading zeros and computing the minimal length and using that representation for the value.
- Nonintegral index values are illegal and result in an error.
- A 4-state index value containing `x` or `z` is invalid.
- Indexing expressions are self-determined and treated as unsigned.
- A string literal index is automatically cast to a bit vector of equivalent size.
- The ordering is numerical (smallest to largest).
- Associative arrays that specify a wildcard index type shall not be used in a **foreach** loop (see [12.7.3](#)) or with an array manipulation method (see [7.12](#)) that returns an index value or array of values.

7.8.2 String index

For example:

```
int array_name [ string ];
```

Associative arrays that specify a string index have the following properties:

- Indices can be strings or string literals of any length. Other types are illegal and shall result in a type check error.
- An empty string `""` index is valid.
- The ordering is lexicographical (lesser to greater).

7.8.3 Class index

For example:

```
int array_name [ some_Class ];
```

Associative arrays that specify a class index have the following properties:

- Indices can be objects of that particular type or derived from that type. Any other type is illegal and shall result in a type check error.
- A null index is valid.
- The ordering is deterministic but arbitrary.

7.8.4 Integral index

For example:

```
int array_name1 [ integer ];
typedef bit signed [4:1] SNibble;
int array_name2 [ SNibble ];
typedef bit [4:1] UNibble;
int array_name3 [ UNibble ];
```

Associative arrays that specify an index of integral data type shall have the following properties:

- The index expression shall be evaluated in terms of a cast to the index type, except that an implicit cast from a real or shortreal data type shall be illegal.
- A 4-state index expression containing X or Z is invalid.
- The ordering is signed or unsigned numerical, depending on the signedness of the index type.

7.8.5 Other user-defined types

For example:

```
typedef struct {byte B; int I[*];} Unpkt;
int array_name [ Unpkt ];
```

In general, associative arrays that specify an index of any type have the following properties:

- Declared indices shall have the equality operator defined for its type to be legal. This includes all of the dynamically sized types as legal index types. However, **real** or **shortreal** data types, or a type containing a **real** or **shortreal** shall be an illegal index type.
- An index expression that is or contains x or z in any of its elements is invalid.
- An index expression that is or contains an empty value or null for any of its elements does not make the index invalid.
- If the relational operator is defined for the index type, the ordering is as defined in the preceding clauses. If not, the relative ordering of any two entries in such an associative array can vary, even between successive runs of the same tool. However, the relative ordering shall remain the same within the same simulation run while no indices have been added or deleted.

7.8.6 Accessing invalid indices

If an invalid index (i.e., 4-state expression has X's) is used during a read operation or an attempt is made to read a nonexistent entry, then a warning shall be issued; and the default initial value for the array type shall

be returned, as shown in [Table 7-1](#). A user specified default shall not issue a warning and returns the value specified in [7.9.11](#).

Table 7-1—Value read from a nonexistent associative array entry

Type of array	Value read
4-state integral type	'X
2-state integral type	'0
enumeration	base type default initial value
string	""
class	null
event	null

If an invalid index is used -during a write operation, the write shall be ignored, and a warning shall be issued.

7.9 Associative array methods

In addition to the indexing operators, several built-in methods are provided, which allow users to analyze and manipulate associative arrays, as well as iterate over its indices or keys.

7.9.1 Num() and size()

The syntax for the `num()` and `size()` methods is as follows:

```
function int num();  
function int size();
```

The `num()` and `size()` methods return the number of entries in the associative array. If the array is empty, they return 0.

```
int imem[int];  
imem[ 2'b3 ] = 1;  
imem[ 16'hffff ] = 2;  
imem[ 4b'1000 ] = 3;  
$display( "%0d entries\n", imem.num ); // prints "3 entries"
```

7.9.2 Delete()

The syntax for the `delete()` method is as follows:

```
function void delete( [input index] );
```

where `index` is an optional index of the appropriate type for the array in question.

If the `index` is specified, then the `delete()` method removes the entry at the specified index. If the entry to be deleted does not exist, the method issues no warning.

If the `index` is not specified, then the `delete()` method removes all the elements in the array.

```

int map[ string ];
map[ "hello" ] = 1;
map[ "sad" ] = 2;
map[ "world" ] = 3;
map.delete( "sad" ); // remove entry whose index is "sad" from "map"
map.delete;         // remove all entries from the associative array "map"

```

7.9.3 Exists()

The syntax for the `exists()` method is as follows:

```

function int exists( input index );

```

where `index` is an index of the appropriate type for the array in question.

The `exists()` function checks whether an element exists at the specified index within the given array. It returns 1 if the element exists; otherwise, it returns 0.

```

if ( map.exists( "hello" ) )
    map[ "hello" ] += 1;
else
    map[ "hello" ] = 0;

```

7.9.4 First()

The syntax for the `first()` method is as follows:

```

function int first( ref index );

```

where `index` is an index of the appropriate type for the array in question. Associative arrays that specify a wildcard index type shall not be allowed.

The `first()` method assigns to the given index variable the value of the first (smallest) index in the associative array. It returns 0 if the array is empty; otherwise, it returns 1.

```

string s;
if ( map.first( s ) )
    $display( "First entry is : map[ %s ] = %0d\n", s, map[s] );

```

7.9.5 Last()

The syntax for the `last()` method is as follows:

```

function int last( ref index );

```

where `index` is an index of the appropriate type for the array in question. Associative arrays that specify a wildcard index type shall not be allowed.

The `last()` method assigns to the given index variable the value of the last (largest) index in the associative array. It returns 0 if the array is empty; otherwise, it returns 1.

```

string s;
if ( map.last( s ) )
    $display( "Last entry is : map[ %s ] = %0d\n", s, map[s] );

```

7.9.6 Next()

The syntax for the `next()` method is as follows:

```
function int next( ref index );
```

where `index` is an index of the appropriate type for the array in question. Associative arrays that specify a wildcard index type shall not be allowed.

The `next()` method finds the smallest index whose value is greater than the given index argument.

If there is a next entry, the index variable is assigned the index of the next entry, and the function returns 1. Otherwise, the index is unchanged, and the function returns 0.

```
string s;  
if ( map.first( s ) )  
  do  
    $display( "%s : %d\n", s, map[ s ] );  
  while ( map.next( s ) );
```

7.9.7 Prev()

The syntax for the `prev()` method is as follows:

```
function int prev( ref index );
```

where `index` is an index of the appropriate type for the array in question. Associative arrays that specify a wildcard index type shall not be allowed.

The `prev()` function finds the largest index whose value is smaller than the given index argument. If there is a previous entry, the index variable is assigned the index of the previous entry, and the function returns 1. Otherwise, the index is unchanged, and the function returns 0.

```
string s;  
if ( map.last( s ) )  
  do  
    $display( "%s : %d\n", s, map[ s ] );  
  while ( map.prev( s ) );
```

7.9.8 Arguments to Traversal Methods

The argument that is passed to any of the four associative array traversal methods `first()`, `last()`, `next()`, and `prev()` shall be assignment compatible with the index type of the array. If the argument has an integral type that is smaller than the size of the corresponding array index type, then the function returns -1 and shall truncate in order to fit into the argument. For example:

```
string aa[int];  
byte ix;  
int status;  
aa[ 1000 ] = "a";  
status = aa.first( ix );  
// status is -1  
// ix is 232 (least significant 8 bits of 1000)
```

7.9.9 Associative array assignment

Associative arrays can be assigned only to another associative array of a compatible type and with the same index type. Other types of arrays cannot be assigned to an associative array, nor can associative arrays be assigned to other types of arrays, whether fixed-size or dynamic.

Assigning an associative array to another associative array causes the target array to be cleared of any existing entries, and then each entry in the source array is copied into the target array.

7.9.10 Associative array arguments

Associative arrays can be passed as arguments only to associative arrays of a compatible type and with the same index type. Other types of arrays, whether fixed-size or dynamic, cannot be passed to subroutines that accept an associative array as an argument. Likewise, associative arrays cannot be passed to subroutines that accept other types of arrays.

Passing an associative array by value causes a local copy of the associative array to be created.

7.9.11 Associative array literals

Associative array literals use the `{index:value}` syntax with an optional default index. Like all other arrays, an associative array can be written one entry at a time, or the whole array contents can be replaced using an array literal.

For example:

```
// an associative array of strings indexed by 2-state integers,  
// default is "hello".  
string words [int] = '{default: "hello"}';  
  
// an associative array of 4-state integers indexed by strings, default is -1  
integer tab [string] = '{"Peter":20, "Paul":22, "Mary":23, default:-1 }';
```

If a default value is specified, then reading a nonexistent element shall yield the specified default value, and no warning shall be issued. Otherwise, the default initial value as described in [Table 7-1](#) shall be returned.

Defining a default value shall not affect the operation of the associative array methods (see [7.9](#)).

7.10 Queues

A queue is a variable-size, ordered collection of homogeneous elements. A queue supports constant-time access to all its elements as well as constant-time insertion and removal at the beginning or the end of the queue. Each element in a queue is identified by an ordinal number that represents its position within the queue, with 0 representing the first, and `$` representing the last. A queue is analogous to a one-dimensional unpacked array that grows and shrinks automatically. Thus, like arrays, queues can be manipulated using the indexing, concatenation, slicing operator syntax, and equality operators.

Queues are declared using the same syntax as unpacked arrays, but specifying `$` as the array size. The maximum size of a queue can be limited by specifying its optional right bound (last index).

Queue values may be written using assignment patterns or unpacked array concatenations (see [10.9](#), [10.10](#)).

The syntax for declaring queues is shown in [Syntax 7-4](#).

```
variable_dimension ::= // from A.2.5
    unsized_dimension
    | unpacked_dimension
    | associative_dimension
    | queue_dimension
queue_dimension ::= [ $ [ : constant_expression ] ]
```

Syntax 7-4—Declaration of queue dimension (excerpt from [Annex A](#))

constant_expression shall evaluate to a positive integer value.

For example:

```
byte q1[$];           // A queue of bytes
string names[$] = { "Bob" }; // A queue of strings with one element
integer Q[$] = { 3, 2, 7 }; // An initialized queue of integers
bit q2[$:255];       // A queue whose maximum size is 256 bits
```

The empty array literal {} is used to denote an empty queue. If an initial value is not provided in the declaration, the queue variable is initialized to the empty queue.

7.10.1 Queue operators

Queues shall support the same operations that can be performed on unpacked arrays. In addition, queues shall support the following operations:

- A queue shall resize itself to accommodate any queue value that is written to it, except that its maximum size may be bounded as described in [7.10](#).
- In a queue slice expression such as $Q[a:b]$, the slice bounds may be arbitrary integral expressions and, in particular, are not required to be constant expressions.
- Queues shall support methods as described in [7.10.2](#).

Unlike arrays, the empty queue, {}, is a valid queue and the result of some queue operations. The following rules govern queue operators:

- $Q[a : b]$ yields a queue with $b - a + 1$ elements.
 - If $a > b$, then $Q[a:b]$ yields the empty queue {}.
 - $Q[n : n]$ yields a queue with one item, the one at position n . Thus, $Q[n : n] === \{ Q[n] \}$.
 - If n lies outside Q 's range ($n < 0$ or $n > \$$), then $Q[n:n]$ yields the empty queue {}.
 - If either a or b are 4-state expressions containing x or z values, it yields the empty queue {}.
- $Q[a : b]$ where $a < 0$ is the same as $Q[0 : b]$.
- $Q[a : b]$ where $b > \$$ is the same as $Q[a : \$]$.
- An invalid index value (i.e., a 4-state expression with x 's or z 's, or a value that lies outside $0..\$$) shall cause a read operation ($e = Q[n]$) to return the default initial value for the type of queue item (as described in [Table 7-1](#)).
- An invalid index (i.e., a 4-state expression with x 's or z 's, or a value that lies outside $0..\$+1$) shall cause a write operation to be ignored and a run-time warning to be issued; however, writing to $Q[\$+1]$ is legal.

- A queue declared with a right bound using the syntax [$\$: N$] is known as a *bounded queue* and shall be limited to have indices not greater than N (its size shall not exceed $N+1$). The additional rules governing bounded queues are described in [7.10.5](#).

7.10.2 Queue methods

In addition to the array operators, queues provide several built-in methods. Assume these declarations for the examples that follow:

```
typedef mytype element_t; // mytype is any legal type for a queue
typedef element_t queue_t[$];
element_t e;
queue_t Q;
int i;
```

7.10.2.1 Size()

The prototype for the `size()` method is as follows:

```
function int size();
```

The `size()` method returns the number of items in the queue. If the queue is empty, it returns 0.

```
for ( int j = 0; j < Q.size; j++ ) $display( Q[j] );
```

7.10.2.2 Insert()

The prototype of the `insert()` method is as follows:

```
function void insert(input int index, input element_t item);
```

The `insert()` method inserts the given item at the specified index position.

7.10.2.3 Delete()

The syntax for the `delete()` method is as follows:

```
function void delete( [int index] );
```

where `index` is an optional index.

If the index is specified, then the `delete()` method deletes the item at the specified index position.

If the index is not specified, then the `delete()` method deletes all the elements in the queue, leaving the queue empty.

7.10.2.4 Pop_front()

The prototype of the `pop_front()` method is as follows:

```
function element_t pop_front();
```

The `pop_front()` method removes and returns the first element of the queue.

7.10.2.5 Pop_back()

The prototype of the `pop_back()` method is as follows:

```
function element_t pop_back();
```

The `pop_back()` method removes and returns the last element of the queue.

7.10.2.6 Push_front()

The prototype of the `push_front()` method is as follows:

```
function void push_front(input element_t item);
```

The `push_front()` method inserts the given element at the front of the queue.

7.10.2.7 Push_back()

The prototype of the `push_back()` method is as follows:

```
function void push_back(input element_t item);
```

The `push_back()` method inserts the given element at the end of the queue.

7.10.3 Persistence of references to elements of a queue

As described in [13.5.2](#), it is possible for an element of a queue to be passed by reference to a task that continues to hold the reference while other operations are performed on the queue. Some operations on the queue shall cause any such reference to become outdated (as defined in [13.5.2](#)). This subclause defines the situations in which a reference to a queue element shall become outdated.

When any of the queue methods described in [7.10.2](#) updates a queue, a reference to any existing element that is not deleted by the method shall not become outdated. All elements that are removed from the queue by the method shall become outdated references.

When the target of an assignment is an entire queue, references to any element of the original queue shall become outdated.

As a consequence of this clause, inserting elements in a queue using unpacked array concatenation syntax, as illustrated in the examples in [7.10.4](#), will cause all references to any element of the existing queue to become outdated. Use of the `delete`, `pop_front` and `pop_back` methods will outdate any reference to the popped or deleted element, but will leave references to all other elements of the queue unaffected. By contrast, use of the `insert`, `push_back` and `push_front` methods on a queue can never give rise to outdated references (except that `insert` or `push_front` on a bounded queue would cause the highest-numbered element of the queue to be deleted if the new size of the queue were to exceed the queue's bound).

7.10.4 Updating a queue using assignment and unpacked array concatenation

As described in [7.10](#), a queue variable may be updated by assignment. Together with unpacked array concatenation, this offers a flexible alternative to the queue methods described in [7.10.2](#) when performing operations on a queue variable.

The following examples show queue assignment operations that exhibit behaviors similar to those of queue methods. In each case the resulting value of the queue variable shall be the same as if the queue method had

been applied, but any reference to elements of the queue will become outdated by the assignment operation (see [7.10.3](#)):

```

int q[$] = { 2, 4, 8 };
int e, pos, junk;

// assignment                                // method call yielding the
//                                           // same value in variable q
// -----                                // -----
q = { q, 6 };                                // q.push_back(6)
q = { e, q };                                // q.push_front(e)
q = q[1:$];                                  // q.pop_front(junk) or q.delete(0)
q = q[0:$-1];                                // q.pop_back(junk) or q.delete(q.size-1)
q = { q[0:pos-1], e, q[pos:$] };             // q.insert(pos, e)
q = { q[0:pos], e, q[pos+1:$] };             // q.insert(pos+1, e)
q = {};                                       // q.delete()

```

Some useful operations that cannot be implemented as a single queue method call are illustrated in the following examples. As in the examples above, assignment to the queue variable outdates any reference to its elements.

```

q = q[2:$];          // a new queue lacking the first two items
q = q[1:$-1];       // a new queue lacking the first and last items

```

7.10.5 Bounded queues

A bounded queue shall not have an element whose index is higher than the queue’s declared upper bound. Operations on bounded queues shall behave exactly as if the queue were unbounded except that if, after any operation that writes to a bounded queue variable, that variable has any elements beyond its bound, then all such out-of-bounds elements shall be discarded and a warning shall be issued.

NOTE—Implementations may meet this requirement in any way that achieves the same result. In particular, they are not required to write the out-of-bounds elements before discarding them.

7.11 Array querying functions

SystemVerilog provides new system functions to return information about an array. These are `$left`, `$right`, `$low`, `$high`, `$increment`, `$size`, `$dimensions`, and `$unpacked_dimensions`. These functions are described in [20.7](#).

7.12 Array manipulation methods

SystemVerilog provides several built-in methods to facilitate array searching, ordering, and reduction.

The general syntax to call these array methods is as follows:

```

array_method_call ::=
  expression . array_method_name { attribute_instance } [ ( iterator_argument ) ]
  [ with ( expression ) ]

```

Syntax 7-5—Array method call syntax (not in [Annex A](#))

The optional **with** clause accepts an expression enclosed in parentheses. In contrast, the **with** clause used by the `randomize` method (see [18.7](#)) accepts a set of constraints enclosed in braces.

If the expression contained in the **with** clause includes any side effects, the results may be unpredictable.

Array manipulation methods iterate over the array elements, which are then used to evaluate the expression specified by the **with** clause. The *iterator_argument* optionally specifies the name of the variable used by the **with** expression to designate the element of the array at each iteration. If it is not specified, the name `item` is used by default. The scope for the *iterator_argument* is the **with** expression. Specifying an *iterator_argument* without also specifying a **with** clause shall be illegal.

7.12.1 Array locator methods

Array locator methods operate on any unpacked array, including queues, but their return type is a queue. These locator methods allow searching an array for elements (or their indices) that satisfy a given expression. Array locator methods traverse the array in an unspecified order.

Index locator methods return a queue of `int` for all arrays except associative arrays, which return a queue of the same type as the associative index type. Associative arrays that specify a wildcard index type shall not be allowed.

If no elements satisfy the given expression or the array is empty (in the case of a queue or dynamic array), then an empty queue is returned. Otherwise, these methods return a queue containing all items that satisfy the expression. Index locator methods return a queue with the indices of all items that satisfy the expression. The optional expression specified by the **with** clause shall evaluate to a Boolean value.

The following locator methods are supported (the **with** clause is mandatory):

- `find()` returns all the elements satisfying the given expression.
- `find_index()` returns the indices of all the elements satisfying the given expression.
- `find_first()` returns the first element satisfying the given expression.
- `find_first_index()` returns the index of the first element satisfying the given expression.
- `find_last()` returns the last element satisfying the given expression.
- `find_last_index()` returns the index of the last element satisfying the given expression.

The first or last element is defined as being closest to the leftmost or rightmost indexed element respectively, except for an associative array, which shall use the element closest to the index returned by the first or last method for the associative array index type.

For the following locator methods, the **with** clause (and its expression) may be omitted if the relational operators (`<`, `>`, `==`) are defined for the element type of the given array. If a **with** clause is specified, the relational operators (`<`, `>`, `==`) shall be defined for the type of the expression.

- `min()` returns the element with the minimum value or whose expression evaluates to a minimum.
- `max()` returns the element with the maximum value or whose expression evaluates to a maximum.
- `unique()` returns all elements with unique values or whose expression evaluates to a unique value. The queue returned contains one and only one entry for each of the values found in the array. The ordering of the returned elements is unrelated to the ordering of the original array.
- `unique_index()` returns the indices of all elements with unique values or whose expression evaluates to a unique value. The queue returned contains one and only one entry for each of the values found in the array. The ordering of the returned elements is unrelated to the ordering of the original array. The index returned for duplicate valued entries may be the index for one of the duplicates.

Examples:

```

string SA[10], qs[$];
int IA[int], qi[$];

// Find all items greater than 5
qi = IA.find( x ) with ( x > 5 );
qi = IA.find( x ); // shall be an error

// Find indices of all items equal to 3
qi = IA.find_index with ( item == 3 );

// Find first item equal to Bob
qs = SA.find_first with ( item == "Bob" );

// Find last item equal to Henry
qs = SA.find_last( y ) with ( y == "Henry" );

// Find index of last item greater than Z
qi = SA.find_last_index( s ) with ( s > "Z" );

// Find smallest item
qi = IA.min;

// Find string with largest numerical value
qs = SA.max with ( item.atoi );

// Find all unique string elements
qs = SA.unique;

// Find all unique strings in lowercase
qs = SA.unique( s ) with ( s.toLowerCase );

```

7.12.2 Array ordering methods

Array ordering methods reorder the elements of any unpacked array (fixed or dynamically sized) except for associative arrays.

The prototype for the ordering methods is as follows:

```

function void ordering_method ( array_type iterator = item );

```

The following ordering methods are supported:

- `reverse()` reverses the order of the elements in the array. Specifying a **with** clause shall be a compiler error.
- `sort()` sorts the array in ascending order, optionally using the expression in the **with** clause. The **with** clause (and its expression) is optional when the relational operators (<, >, ==) are defined for the array element type. If a **with** clause is specified, the relational operators (<, >, ==) shall be defined for the type of the expression.
- `rsort()` sorts the array in descending order, optionally using the expression in the **with** clause. The **with** clause (and its expression) is optional when the relational operators (<, >, ==) are defined for the array element type. If a **with** clause is specified, the relational operators (<, >, ==) shall be defined for the type of the expression.
- `shuffle()` randomizes the order of the elements in the array. Specifying a **with** clause shall be a compiler error.

Examples:

```

string s[] = { "hello", "sad", "world" };
s.reverse;           // s becomes { "world", "sad", "hello" };

int q[$] = { 4, 5, 3, 1 };
q.sort;             // q becomes { 1, 3, 4, 5 }

struct { byte red, green, blue; } c [512];
c.sort with ( item.red ); // sort c using the red field only
c.sort( x ) with ( {x.blue, x.green} ); // sort by blue then green

```

7.12.3 Array reduction methods

Array reduction methods may be applied to any unpacked array of integral values to reduce the array to a single value. The expression within the optional **with** clause is used to specify the values to use in the reduction. The values produced by evaluating this expression for each array element are used by the reduction method. This is in contrast to the array locator methods (see [7.12.1](#)) where the **with** clause is used as a selection criteria.

The prototype for these methods is as follows:

```

function expression_or_array_type reduction_method (array_type iterator = item);

```

The method returns a single value of the same type as the array element type or, if specified, the type of the expression in the **with** clause. The **with** clause may be omitted if the corresponding arithmetic or Boolean reduction operation is defined for the array element type. If a **with** clause is specified, the corresponding arithmetic or Boolean reduction operation shall be defined for the type of the expression.

The following reduction methods are supported:

- **sum()** returns the sum of all the array elements or, if a **with** clause is specified, returns the sum of the values yielded by evaluating the expression for each array element.
- **product()** returns the product of all the array elements or, if a **with** clause is specified, returns the product of the values yielded by evaluating the expression for each array element.
- **and()** returns the bitwise AND (&) of all the array elements or, if a **with** clause is specified, returns the bitwise AND of the values yielded by evaluating the expression for each array element.
- **or()** returns the bitwise OR (|) of all the array elements or, if a **with** clause is specified, returns the bitwise OR of the values yielded by evaluating the expression for each array element.
- **xor()** returns the bitwise XOR (^) of all the array elements or, if a **with** clause is specified, returns the bitwise XOR of the values yielded by evaluating the expression for each array element.

Examples:

```

byte b[] = { 1, 2, 3, 4 };
int y;
y = b.sum ; // y becomes 10 => 1 + 2 + 3 + 4
y = b.product ; // y becomes 24 => 1 * 2 * 3 * 4
y = b.xor with ( item + 4 ); // y becomes 12 => 5 ^ 6 ^ 7 ^ 8

logic [7:0] m [2][2] = '{ {5, 10}, {15, 20} }';
int y;
y = m.sum with (item.sum with (item)); // y becomes 50 => 5+10+15+20

logic bit_arr [1024];
int y;

```

```
y = bit_arr.sum with ( int'(item) ); // forces result to be 32-bit
```

The last example shows how the result of calling `sum` on a bit array can be forced to be a 32-bit quantity. By default, the result of calling `sum` would be of type `logic` in this example. Summing the values of 1024 bits could overflow the result. This overflow can be avoided by using a `with` clause. When specified, the `with` clause is used to determine the type of the result. Casting `item` to an `int` in the `with` clause causes the array elements to be extended to 32 bits before being summed. The result of calling `sum` in this example is 32-bits since the width of the reduction method result shall be the same as the width of the expression in the `with` clause.

7.12.4 Iterator index querying

The expressions used by array manipulation methods sometimes need the actual array indices at each iteration, not just the array element. The `index` method of an iterator returns the index value of the specified dimension. The prototype of the `index` method is as follows:

```
function int_or_index_type index ( int dimension = 1 );
```

The array dimensions are numbered as defined in [20.7](#): The slowest varying is dimension 1. Successively faster varying dimensions have sequentially higher dimension numbers. If the dimension is not specified, the first dimension is used by default.

The return type of the `index` method is an `int` for all array iterator items except associative arrays, which return an index of the same type as the associative index type. Associative arrays that specify a wildcard index type shall not be allowed.

For example:

```
int arr[];  
int q[$];  
...  
  
// find all items equal to their position (index)  
q = arr.find with ( item == item.index );
```

8. Classes

8.1 General

This clause describes the following:

- Class definitions
- Virtual classes and methods
- Polymorphism
- Parameterized classes
- Memory management

8.2 Overview

A class is a type that includes data and subroutines (functions and tasks) that operate on those data. A class's data are referred to as *class properties*, and its subroutines are called *methods*; both are members of the class. The class properties and methods, taken together, define the contents and capabilities of some kind of object.

For example, a packet might be an object. It might have a command field, an address, a sequence number, a time stamp, and a packet payload. In addition, there are various things that can be done with a packet: initialize the packet, set the command, read the packet's status, or check the sequence number. Each packet is different; but as a class, packets have certain intrinsic properties that can be captured in a definition.

```

class Packet ;
    //data or class properties
    bit [3:0] command;
    bit [40:0] address;
    bit [4:0] master_id;
    integer time_requested;
    integer time_issued;
    integer status;

    // initialization
    function new();
        command = IDLE;
        address = 41'b0;
        master_id = 5'bx;
    endfunction

    // methods
    // public access entry points
    task clean();
        command = 0; address = 0; master_id = 5'bx;
    endtask

    task issue_request( int delay );
        // send request to bus
    endtask

    function integer current_status();
        current_status = status;
    endfunction
endclass

```

The object-oriented class extension allows objects to be created and destroyed dynamically. Class instances, or objects, can be passed around via object handles, which provides a safe-pointer capability. An object can be declared as an argument with direction **input**, **output**, **inout**, or **ref**. In each case, the argument copied is the object handle, not the contents of the object.

8.3 Syntax

```

class_declaration ::=
    [ virtual ] class [ lifetime ] class_identifier [ parameter_port_list ]
    [ extends class_type [ ( list_of_arguments ) ] ];
    { class_item }
    endclass [ : class_identifier]
                                                                    //from A.1.2

class_item ::=
    { attribute_instance } class_property
  | { attribute_instance } class_method
  | { attribute_instance } class_constraint
  | { attribute_instance } class_declaration
  | { attribute_instance } covergroup_declaration
  | local_parameter_declaration ;
  | parameter_declaration7 ;
  | ;
                                                                    //from A.1.9

class_property ::=
    { property_qualifier } data_declaration
  | const { class_item_qualifier } data_type const_identifier [ = constant_expression ] ;

class_method ::=
    { method_qualifier } task_declaration
  | { method_qualifier } function_declaration
  | extern { method_qualifier } method_prototype ;
  | { method_qualifier } class_constructor_declaration
  | extern { method_qualifier } class_constructor_prototype

class_constructor_prototype ::=
    function new ( [ tf_port_list ] ) ;

class_constraint ::=
    constraint_prototype
  | constraint_declaration

class_item_qualifier8 ::=
    static
  | protected
  | local

property_qualifier8 ::=
    random_qualifier
  | class_item_qualifier

random_qualifier8 ::=
    rand
  | randc

method_qualifier8 ::=
    [ pure ] virtual
  | class_item_qualifier
  
```

```
method_prototype ::=
    task_prototype
  | function_prototype
```

- 7) In a parameter_declaration that is a class_item, the **parameter** keyword shall be a synonym for the **local-param** keyword.
- 8) In any one declaration, only one of **protected** or **local** is allowed, only one of **rand** or **randc** is allowed, and **static** and/or **virtual** can appear only once.

Syntax 8-1—Class syntax (excerpt from Annex A)

8.4 Objects (class instance)

A class defines a data type. An object is an instance of that class. An object is used by first declaring a variable of that class type (that holds an object handle) and then creating an object of that class (using the **new** function) and assigning it to the variable.

```
Packet p; // declare a variable of class Packet
p = new; // initialize variable to a new allocated object
// of the class Packet
```

The variable `p` is said to hold an object handle to an object of class `Packet`.

Uninitialized object handles are set by default to the special value **null**. An uninitialized object can be detected by comparing its handle with **null**.

For example: The task `task1` below checks whether the object is initialized. If it is not, it creates a new object via the **new** command.

```
class obj_example;
    ...
endclass

task task1(integer a, obj_example myexample);
    if (myexample == null) myexample = new;
endtask
```

Accessing nonstatic members (see 8.8) or virtual methods (see 8.19) via a **null** object handle is illegal. The result of an illegal access via a null object is indeterminate, and implementations may issue an error.

SystemVerilog objects are referenced using an object handle. There are some differences between a C pointer and a SystemVerilog object handle (see Table 8-1). C pointers give programmers a lot of latitude in how a pointer can be used. The rules governing the usage of SystemVerilog object handles are much more restrictive. A C pointer can be incremented, for example; but a SystemVerilog object handle cannot. In addition to object handles, 6.14 introduces the **chandle** data type for use with the DPI (see Clause 35).

Table 8-1—Comparison of pointer and handle types

Operation	C pointer	SV object handle	SV chandle
Arithmetic operations (such as incrementing)	Allowed	Not allowed	Not allowed
For arbitrary data types	Allowed	Not allowed	Not allowed

Table 8-1—Comparison of pointer and handle types (continued)

Operation	C pointer	SV object handle	SV chandle
Dereference when null	Error	Error, see text above	Not allowed
Casting	Allowed	Limited	Not allowed
Assignment to an address of a data type	Allowed	Not allowed	Not allowed
Unreferenced objects are garbage collected	No	Yes	No
Default value	Undefined	null	null
For classes	(C++)	Allowed	Not allowed

Only the following operators are valid on object handles:

- Equality (==), inequality (!=) with another class object or with **null**. One of the objects being compared must be assignment compatible with the other.
- Case equality (===), case inequality (!==) with another class object or with **null** (same semantics as == and !=).
- Conditional operator (see [11.4.11](#)).
- Assignment of a class object whose class datatype is assignment compatible with the target class object.
- Assignment of **null**.

8.5 Object properties and object parameter data

The data fields of an object can be used by qualifying class property names with an instance name. Using the earlier example, the commands for the `Packet` object `p` can be used as follows:

```
Packet p = new;
p.command = INIT;
p.address = $random;
packet_time = p.time_requested;
```

There are no restrictions on the data type of a class property.

The parameter data values of an object can also be accessed by qualifying the class value parameter or local value parameter name with an instance name. Example:

```
class vector #(parameter width = 7);
endclass

vector #(3) v = new;

initial $display (v.width);
```

Such an expression is not a constant expression.

8.6 Object methods

An object's methods can be accessed using the same syntax used to access class properties:

```
Packet p = new;
status = p.current_status();
```

The above assignment to `status` cannot be written as follows:

```
status = current_status(p);
```

The focus in object-oriented programming is the object, in this case the packet, not the function call. Also, objects are self-contained, with their own methods for manipulating their own properties. Therefore, the object does not have to be passed as an argument to `current_status()`. A class's properties are freely and broadly available to the methods of the class, but each method only accesses the properties associated with its object, i.e., its instance.

The lifetime of methods declared as part of a class type shall be automatic. It shall be illegal to declare a class method with a static lifetime.

8.7 Constructors

SystemVerilog does not require the complex memory allocation and deallocation of C++. Construction of an object is straightforward; and garbage collection, as in Java, is implicit and automatic. There can be no memory leaks or other subtle behaviors, which are so often the bane of C++ programmers.

SystemVerilog provides a mechanism for initializing an instance at the time the object is created. When an object is created, for example,

```
Packet p = new;
```

The system executes the `new` function associated with the class:

```
class Packet;
  integer command;

  function new();
    command = IDLE;
  endfunction
endclass
```

As shown above, `new` is now being used in two very different contexts with very different semantics. The variable declaration creates an object of class `Packet`. In the course of creating this instance, the `new` function is invoked, in which any specialized initialization required can be done. The `new` function is also called the *class constructor*.

The `new` operation is defined as a function with no return type, and like any other function, it shall be non-blocking. Even though `new` does not specify a return type, the left-hand side of the assignment determines the return type.

If a class does not provide an explicit user defined `new` method, an implicit `new` method shall be provided automatically. The `new` method of a derived class shall first call its base class constructor [`super.new()` as described in [8.14](#)]. After the base class constructor call (if any) has completed, each property defined in the class shall be initialized to its explicit default value or its uninitialized value if no default is provided. After the properties are initialized, the remaining code in a user-defined constructor shall be evaluated. The default constructor has no additional effect after the property initialization. The value of a property prior to its initialization shall be undefined.

Example:

```
class C;
  int c1 = 1;
  int c2 = 1;
  int c3 = 1;
  function new(int a);
    c2 = 2;
    c3 = a;
  endfunction
endclass

class D extends C;
  int d1 = 4;
  int d2 = c2;
  int d3 = 6;
  function new;
    super.new(d3);
  endfunction
endclass
```

After the construction of an object of type D is complete, the properties are as follows:

- c1 has the value 1
- c2 has the value 2 since the constructor assignment happens after the property initialization
- c3 has an undefined value since the constructor call from D passes in the value of d3 which is undefined when the `super.new(d3)` call is made.
- d1 has the value 4
- d2 has the value 2 since the `super.new` call is complete when d2 is initialized
- d3 has the value 6

It is also possible to pass arguments to the constructor, which allows run-time customization of an object:

```
Packet p = new(STARTUP, $random, $time);
```

where the `new` initialization task in `Packet` might now look like the following:

```
function new(int cmd = IDLE, bit[12:0] adrs = 0, int cmd_time );
  command = cmd;
  address = adrs;
  time_requested = cmd_time;
endfunction
```

The conventions for arguments are the same as for any other procedural subroutine calls, such as the use of default arguments.

A constructor may be declared as a `local` or `protected` method (see [8.17](#)). A constructor shall not be declared as a `static` (see [8.9](#)) or `virtual` method (see [8.19](#)).

8.8 Static class properties

The previous examples have only declared instance class properties. Each instance of the class (i.e., each object of type `Packet`) has its own copy of each of its six variables. Sometimes only one version of a variable is required to be shared by all instances. These class properties are created using the keyword `static`. Thus, for example, in the following case, all instances of a class need access to a common file descriptor:

```
class Packet ;  
    static integer fileID = $fopen( "data", "r" );
```

Now, `fileID` shall be created and initialized once. Thereafter, every `Packet` object can access the file descriptor in the usual way:

```
Packet p;  
c = $fgetc( p.fileID );
```

The static class properties can be used without creating an object of that type.

8.9 Static methods

Methods can be declared as **static**. A static method is subject to all the class scoping and access rules, but behaves like a regular subroutine that can be called outside the class, even with no class instantiation. A static method has no access to nonstatic members (class properties or methods), but it can directly access static class properties or call static methods of the same class. Access to nonstatic members or to the special **this** handle within the body of a static method is illegal and results in a compiler error. Static methods cannot be virtual.

```
class id;  
    static int current = 0;  
    static function int next_id();  
        next_id = ++current; // OK to access static class property  
    endfunction  
endclass
```

A static method is different from a task with static lifetime. The former refers to the lifetime of the method within the class, while the latter refers to the lifetime of the arguments and variables within the task.

```
class TwoTasks;  
    static task t1(); ... endtask // static class method with  
                                // automatic variable lifetime  
  
    task static t2(); ... endtask // ILLEGAL: nonstatic class method with  
                                // static variable lifetime  
endclass
```

8.10 This

The **this** keyword is used to unambiguously refer to class properties, value parameters, local value parameters or methods of the current instance. The **this** keyword denotes a predefined object handle that refers to the object that was used to invoke the subroutine that **this** is used within. The **this** keyword shall only be used within nonstatic class methods; otherwise, an error shall be issued. For example, the following declaration is a common way to write an initialization task:

```
class Demo ;  
    integer x;  
  
    function new (integer x);  
        this.x = x;  
    endfunction  
endclass
```

The `x` is now both a property of the class and an argument to the function `new`. In the function `new`, an unqualified reference to `x` shall be resolved by looking at the innermost scope, in this case, the subroutine argument declaration. To access the instance class property, it is qualified with the `this` keyword, to refer to the current instance.

NOTE—In writing methods, members can be qualified with `this` to refer to the current instance, but it is usually unnecessary.

8.11 Assignment, renaming, and copying

Declaring a class variable only creates the name by which the object is known. Thus,

```
Packet p1;
```

creates a variable, `p1`, that can hold the handle of an object of class `Packet`, but the initial value of `p1` is `null`. The object does not exist, and `p1` does not contain an actual handle, until an instance of type `Packet` is created:

```
p1 = new;
```

Thus, if another variable is declared and assigned the old handle, `p1`, to the new one, as in

```
Packet p2;  
p2 = p1;
```

then there is still only one object, which can be referred to with either the name `p1` or `p2`. In this example, `new` was executed only once; therefore, only one object has been created.

If, however, the example above is rewritten as follows, a copy of `p1` shall be made:

```
Packet p1;  
Packet p2;  
p1 = new;  
p2 = new p1;
```

The last statement has `new` executing a second time, thus creating a new object `p2`, whose class properties are copied from `p1`. This is known as a *shallow copy*. All of the variables are copied across integers, strings, instance handles, etc. Objects, however, are not copied, only their handles; as before, two names for the same object have been created. This is true even if the class declaration includes the instantiation operator `new`.

A *shallow copy* executes in the following manner:

- 1) An object of the class type being copied is allocated. This allocation shall not call the object's constructor or execute any variable declaration initialization assignments.
- 2) All class properties, including the internal states used for randomization and coverage are copied to the new object. Object handles are copied; this includes the object handles for covergroup objects (see [Clause 19](#)). An exception is made for embedded covergroups (see [19.4](#)). The object handle of an embedded covergroup shall be set to null in the new object. The internal states for randomization include the random number generator (RNG) state, the `constraint_mode` status of constraints, the `rand_mode` status of random variables, and the cyclic state of `randc` variables (see [Clause 18](#)).
- 3) A handle to the newly created object is assigned to the variable on the left-hand side.

NOTE—A shallow copy does not create new coverage objects (covergroup instances). As a result, the properties of the new object are not covered.

```

class baseA ;
  integer j = 5;
endclass

class B ;
  integer i = 1;
  baseA a = new;
endclass

class xtndA extends baseA;
  rand int x;
  constraint cst1 { x < 10; }
endclass

function integer test;
  xtndA xtnd1;
  baseA base2, base3;
  B b1 = new;           // Create an object of class B
  B b2 = new b1;       // Create an object that is a copy of b1
  b2.i = 10;           // i is changed in b2, but not in b1
  b2.a.j = 50;         // change a.j, shared by both b1 and b2
  test = b1.i;         // test is set to 1 (b1.i has not changed)
  test = b1.a.j;       // test is set to 50 (a.j has changed)
  xtnd1 = new;         // create a new instance of class xtndA
  xtnd1.x = 3;
  base2 = xtnd1;       // base2 refers to the same object as xtnd1
  base3 = new base2;   // Creates a shallow copy of xtnd1
endfunction

```

In the last statement `base3` is assigned a shallow copy of `base2`. The type of the variable `base3` is a handle to the base class `baseA`. When the shallow copy is invoked, this variable contains a handle to an instance of the extended class `xtndA`. The shallow copy creates a duplicate of the referenced object, resulting in a duplicate instance of the extended class `xtndA`. The handle to this instance is then assigned to the variable `base3`.

Several things are noteworthy. First, class properties and instantiated objects can be initialized directly in a class declaration. Second, the shallow copy does not copy objects. Third, instance qualifications can be chained as needed to reach into objects or to reach through objects:

```

b1.a.j           // reaches into a, which is a property of b1
p.next.next.next.val // chain through a sequence of handles to get to val

```

To do a full (deep) copy, where everything (including nested objects) is copied, custom code is typically needed. For example:

```

Packet p1 = new;
Packet p2 = new;
p2.copy(p1);

```

where `copy(Packet p)` is a custom method written to copy the object specified as its argument into its instance.

8.12 Inheritance and subclasses

The previous subclauses defined a class called `Packet`. This class can be extended so that the packets can be chained together into a list. One solution would be to create a new class called `LinkedPacket` that contains a variable of type `Packet` called `packet_c`.

To refer to a class property of `Packet`, the variable `packet_c` needs to be referenced.

```
class LinkedPacket;
    Packet packet_c;
    LinkedPacket next;

    function LinkedPacket get_next();
        get_next = next;
    endfunction
endclass
```

Because `LinkedPacket` is a special form of `Packet`, a more elegant solution is to extend the class creating a new subclass that *inherits* the members of the base class. Thus, for example:

```
class LinkedPacket extends Packet;
    LinkedPacket next;

    function LinkedPacket get_next();
        get_next = next;
    endfunction
endclass
```

Now, all of the methods and class properties of `Packet` are part of `LinkedPacket` (as if they were defined in `LinkedPacket`), and `LinkedPacket` has additional class properties and methods.

The methods of the base class can also be overridden to change their definitions.

The mechanism provided by SystemVerilog is called *single inheritance*, that is, each class is derived from a single base class.

8.13 Overridden members

Subclass objects are also legal representative objects of their base classes. For example, every `LinkedPacket` object is a perfectly legal `Packet` object.

The handle of a `LinkedPacket` object can be assigned to a `Packet` variable:

```
LinkedPacket lp = new;
Packet p = lp;
```

In this case, references to `p` access the methods and class properties of the `Packet` class. So, for example, if class properties and methods in `LinkedPacket` are overridden, these overridden members referred to through `p` get the original members in the `Packet` class. From `p`, `new` and all overridden members in `LinkedPacket` are now hidden.

```
class Packet;
    integer i = 1;
    function integer get();
        get = i;
    endfunction
endclass

class LinkedPacket extends Packet;
    integer i = 2;
    function integer get();
        get = -i;
    endfunction
endclass
```

```

    endfunction
endclass

LinkedPacket lp = new;
Packet p = lp;
j = p.i;           // j = 1, not 2
j = p.get();      // j = 1, not -1 or -2

```

To call the overridden method via a base class object (p in the example), the method needs to be declared **virtual** (see [8.19](#)).

8.14 Super

The **super** keyword is used from within a derived class to refer to members, class value parameters or local value parameters of the base class. It is necessary to use **super** to access members, value parameters or local value parameters of a base class when those are overridden by the derived class. An expression using **super** to access the value parameter or local value parameter is not a constant expression.

```

class Packet;                               // base class
    integer value;
    function integer delay();
        delay = value * value;
    endfunction
endclass

class LinkedPacket extends Packet;          // derived class
    integer value;
    function integer delay();
        delay = super.delay()+ value * super.value;
    endfunction
endclass

```

The member, value parameter or local value parameter can be declared a level up or be inherited by the class one level up. There is no way to reach higher (for example, `super.super.count` is not allowed).

Subclasses (or derived classes) are classes that are extensions of the current class whereas superclasses (base classes) are classes from which the current class is extended, beginning with the original base class.

A **super.new** call shall be the first statement executed in the constructor. This is because the superclass shall be initialized before the current class and, if the user code does not provide an initialization, the compiler shall insert a call to **super.new** automatically.

8.15 Casting

It is always legal to assign a subclass variable to a variable of a class higher in the inheritance tree. It is never legal to directly assign a superclass variable to a variable of one of its subclasses. However, it is legal to assign a superclass handle to a subclass variable if the superclass handle refers to an object of the given subclass.

To check whether the assignment is legal, the dynamic cast function `$cast` is used (see [6.24.2](#)).

The syntax for `$cast` is as follows:

```

task $cast( singular dest_handle, singular source_handle );

```

or

```
function int $cast( singular dest_handle, singular source_handle );
```

When used with object handles, `$cast` checks the hierarchy tree (super and subclasses) of the *source_handle* to see whether it contains the class of *dest_handle*. If it does, `$cast` does the assignment. Otherwise, the error handling is as described in [6.24.2](#).

8.16 Chaining constructors

When a subclass is instantiated, the class method `new()` is invoked. The first action that `new()` takes, before any code defined in the function is evaluated, is to invoke the `new()` method of its superclass and so on up the inheritance hierarchy. Thus, all the constructors are called, in the proper order, beginning with the root base class and ending with the current class. Class property initialization occurs during this sequence as described in [8.7](#).

If the initialization method of the superclass requires arguments, there are two choices: to always supply the same arguments or to use the `super` keyword. If the arguments are always the same, then they can be specified at the time the class is extended:

```
class EtherPacket extends Packet(5);
```

This passes 5 to the `new` routine associated with `Packet`.

A more general approach is to use the `super` keyword, to call the superclass constructor:

```
function new();  
    super.new(5);  
endfunction
```

To use this approach, `super.new(...)` shall be the first executable statement in the function `new`.

If the arguments are specified at the time the class is extended, the subclass constructor shall not contain a `super.new()` call. The compiler shall insert a call to `super.new()` automatically, as whenever the subclass constructor does not contain a `super.new()` call (see [8.14](#)).

NOTE—Declaring a class constructor as a `local` method makes that class inextensible since the reference to `super.new()` in a subclass would be illegal.

8.17 Data hiding and encapsulation

In SystemVerilog, unqualified class properties and methods are public, available to anyone who has access to the object's name. Often, it is desirable to restrict access to class properties and methods from outside the class by hiding their names. This keeps other programmers from relying on a specific implementation, and it also protects against accidental modifications to class properties that are internal to the class. When all data become hidden (i.e., being accessed only by public methods), testing and maintenance of the code become much easier.

Class parameters and class local parameters are also public.

A member identified as `local` is available only to methods inside the class. Further, these local members are not visible within subclasses. Of course, nonlocal methods that access local class properties or methods can be inherited and work properly as methods of the subclass.

A **protected** class property or method has all of the characteristics of a **local** member, except that it can be inherited; it is visible to subclasses.

Within a class, a local method or class property of the same class can be referenced, even if it is in a different instance of the same class. For example:

```
class Packet;
  local integer i;
  function integer compare (Packet other);
    compare = (this.i == other.i);
  endfunction
endclass
```

A strict interpretation of encapsulation might say that `other.i` should not be visible inside this packet because it is a local class property being referenced from outside its instance. Within the same class, however, these references are allowed. In this case, `this.i` shall be compared to `other.i` and the result of the logical comparison returned.

Class members can be identified as either **local** or **protected**; class properties can be further defined as **const**, and methods can be defined as **virtual**. There is no predefined ordering for specifying these modifiers; however, they can only appear once per member. It shall be an error to define members to be both **local** and **protected** or to duplicate any of the other modifiers.

8.18 Constant class properties

Class properties can be made read-only by a **const** declaration like any other SystemVerilog variable. However, because class objects are dynamic objects, class properties allow two forms of read-only variables: global constants and instance constants.

Global constant class properties include an initial value as part of their declaration. They are similar to other **const** variables in that they cannot be assigned a value anywhere other than in the declaration.

```
class Jumbo_Packet;
  const int max_size = 9 * 1024; // global constant
  byte payload [];
  function new( int size );
    payload = new[ size > max_size ? max_size : size ];
  endfunction
endclass
```

Instance constants do not include an initial value in their declaration, only the **const** qualifier. This type of constant can be assigned a value at run time, but the assignment can only be done once in the corresponding class constructor.

```
class Big_Packet;
  const int size; // instance constant
  byte payload [];
  function new();
    size = $random % 4096; //one assignment in new -> ok
    payload = new[ size ];
  endfunction
endclass
```

Typically, global constants are also declared **static** because they are the same for all instances of the class. However, an instance constant cannot be declared **static** because doing so would disallow all assignments in the constructor.

8.19 Virtual methods

A method of a class may be identified with the keyword **virtual**. Virtual methods are a basic polymorphic construct. A virtual method shall override a method in all of its base classes, whereas a non-virtual method shall only override a method in that class and its descendants. One way to view this is that there is only one implementation of a virtual method per class hierarchy, and it is always the one in the latest derived class.

Virtual methods provide prototypes for the methods that later override them, i.e., all of the information generally found on the first line of a method declaration: the encapsulation criteria, the type and number of arguments, and the return type if it is needed. Later, when subclasses override virtual methods, they shall follow the prototype exactly by having matching return types and matching argument names, types, and directions. It is not necessary to have matching default expressions, but the presence of a default shall match.

```
class BasePacket;
    int A = 1;
    int B = 2;
    function void printA;
        $display("BasePacket::A is %d", A);
    endfunction : printA
    virtual function void printB;
        $display("BasePacket::B is %d", B);
    endfunction : printB
endclass : BasePacket

class My_Packet extends BasePacket;
    int A = 3;
    int B = 4;
    function void printA;
        $display("My_Packet::A is %d", A);
    endfunction: printA
    virtual function void printB;
        $display("My_Packet::B is %d", B);
    endfunction : printB
endclass : My_Packet

BasePacket P1 = new;
My_Packet P2 = new;

initial begin
    P1.printA; // displays 'BasePacket::A is 1'
    P1.printB; // displays 'BasePacket::B is 2'
    P1 = P2; // P1 has a handle to a My_packet object
    P1.printA; // displays 'BasePacket::A is 1'
    P1.printB; // displays 'My_Packet::B is 4' - latest derived method
    P2.printA; // displays 'My_Packet::A is 3'
    P2.printB; // displays 'My_Packet::B is 4'
end
```

A virtual method may override a non-virtual method, but once a method has been identified as virtual, it shall remain virtual in any subclass that overrides it. In that case, the **virtual** keyword may be used in later declarations, but is not required.

8.20 Abstract classes and pure virtual methods

A set of classes may be created that can be viewed as all being derived from a common base class. For example, a common base class of type `BasePacket`, that sets out the structure of packets but is incomplete, would never be constructed. This is characterized as an *abstract class*. From this abstract base class, however, a number of useful subclasses may be derived, such as Ethernet packets, token ring packets, GPSS packets, and satellite packets. Each of these packets might look very similar, all needing the same set of methods, but they could vary significantly in terms of their internal details.

A base class may be characterized as being abstract by identifying it with the keyword `virtual`:

```
virtual class BasePacket;  
    ...  
endclass
```

An object of an abstract class shall not be constructed directly. Its constructor may only be called indirectly through the chaining of constructor calls originating in an extended non-abstract object.

A virtual method in an abstract class may be declared as a prototype without providing an implementation. This is called a *pure virtual method* and shall be indicated with the keyword `pure` together with not providing a method body. An extended subclass may provide an implementation by overriding the pure virtual method with a virtual method having a method body.

Abstract classes may be extended to further abstract classes, but all pure virtual methods shall have overridden implementations in order to be extended by a non-abstract class. By having implementations for all its methods, the class is complete and may now be constructed. Any class may be extended into an abstract class, and may provide additional or overridden pure virtual methods.

```
virtual class BasePacket;  
    pure virtual function integer send(bit[31:0] data); // No implementation  
endclass  
  
class EtherPacket extends BasePacket;  
    virtual function integer send(bit[31:0] data);  
        // body of the function  
    ...  
endfunction  
endclass
```

`EtherPacket` is now a class that can have an object of its type constructed.

NOTE—A method without a statement body is still a legal, callable method. For example, if the function `send` was declared as follows, it would have an implementation:

```
virtual function integer send(bit[31:0] data); // Will return 'x'  
endfunction
```

8.21 Polymorphism: dynamic method lookup

Polymorphism allows the use of a variable of the superclass type to hold subclass objects and to reference the methods of those subclasses directly from the superclass variable. As an example, assume the base class for the `Packet` objects, `BasePacket`, defines, as virtual functions, all of the public methods that are to be generally used by its subclasses. Such methods include `send`, `receive`, and `print`. Even though `BasePacket` is abstract, it can still be used to declare a variable:

```
BasePacket packets[100];
```

Now, instances of various packet objects can be created and put into the array:

```
EtherPacket ep = new; // extends BasePacket
TokenPacket tp = new; // extends BasePacket
GPSSPacket gp = new; // extends EtherPacket
packets[0] = ep;
packets[1] = tp;
packets[2] = gp;
```

If the data types were, for example, integers, bits, and strings, all of these types could not be stored into a single array, but with polymorphism, it can be done. In this example, because the methods were declared as **virtual**, the appropriate subclass methods can be accessed from the superclass variable, even though the compiler did not know—at compile time—what was going to be loaded into it.

For example, `packets[1]`

```
packets[1].send();
```

shall invoke the `send` method associated with the `TokenPacket` class. At run time, the system correctly binds the method from the appropriate class.

This is a typical example of polymorphism at work, providing capabilities that are far more powerful than what is found in a nonobject-oriented framework.

8.22 Class scope resolution operator ::

The class scope resolution operator `::` is used to specify an identifier defined within the scope of a class. It has the following form:

```
class_type :: { class_type :: } identifier
```

The left operand of the scope resolution operator `::` shall be a class type name, package name (see [26.2](#)), **covergroup** type name, **coverpoint** name, **cross** name (see [19.5](#), [19.6](#)), **typedef** name or type parameter. When a type name is used, the name shall resolve to a class or covergroup type after elaboration.

Because classes and other scopes can have the same identifiers, the class scope resolution operator uniquely identifies a member, a parameter or local parameter of a particular class. In addition to disambiguating class scope identifiers, the `::` operator also allows access to static members (class properties and methods), class parameters, and class local parameters from outside the class, as well as access to public or protected elements of a superclass from within the derived classes. A class parameter or local parameter is a public element of a class. A class scoped parameter or local parameter is a constant expression.

```
class Base;
  typedef enum {bin,oct,dec,hex} radix;
  static task print( radix r, integer n ); ... endtask
endclass
...
Base b = new;
int bin = 123;
b.print( Base::bin, bin ); // Base::bin and bin are different
Base::print( Base::hex, 66 );
```

In SystemVerilog, the class scope resolution operator applies to all static elements of a class: static class properties, static methods, typedefs, enumerations, parameters, local parameters, constraints, structures, unions, and nested class declarations. Class scope resolved expressions can be read (in expressions), written

(in assignments or subroutines calls), or triggered off (in event expressions). A class scope can also be used as the prefix of a type or a method call.

Like modules, classes are scopes and can nest. Nesting allows hiding of local names and local allocation of resources. This is often desirable when a new type is needed as part of the implementation of a class. Declaring types within a class helps prevent name collisions and the cluttering of the outer scope with symbols that are used only by that class. Type declarations nested inside a class scope are public and can be accessed outside the class.

```

class StringList;
  class Node; // Nested class for a node in a linked list.
    string name;
    Node link;
  endclass
endclass

class StringTree;
  class Node; // Nested class for a node in a binary tree.
    string name;
    Node left, right;
  endclass
endclass
// StringList::Node is different from StringTree::Node

```

The class scope resolution operator enables the following:

- Access to static public members (methods and class properties) from outside the class hierarchy.
- Access to public or protected class members of a superclass from within the derived classes.
- Access to constraints, type declarations and enumeration named constants declared inside the class from outside the class hierarchy or from within derived classes.
- Access to parameters and local parameters declared inside the class from outside the class hierarchy or from within derived classes.

Nested classes shall have the same access rights as methods do in the containing class. They have full access rights to **local** and **protected** methods and properties of the containing class. Nested classes have lexically-scoped, unqualified access to the **static** properties and methods, parameters, and local parameters of the containing class. They shall not have implicit access to non-static properties and methods except through a handle either passed to it or otherwise accessible by it. There is no implicit **this** handle to the outer class. For example:

```

class Outer;
  int                outerProp;
  local int         outerLocalProp;
  static int       outerStaticProp;
  static local int outerLocalStaticProp;
  class Inner;
    function void innerMethod(Outer h);
      outerStaticProp = 0;
      // Legal, same as Outer::outerStaticProp
      outerLocalStaticProp = 0;
      // Legal, nested classes may access local's in outer class
      outerProp = 0;
      // Illegal, unqualified access to non-static outer
      h.outerProp = 0;
      // Legal, qualified access.
      h.outerLocalProp = 0;

```

```
        // Legal, qualified access and locals to outer class allowed.  
    endfunction  
endclass  
endclass
```

The class resolution operator has special rules when used with a prefix that is the name of a parameterized class; see [8.24.1](#) for details.

8.23 Out-of-block declarations

It is convenient to be able to move method definitions out of the body of the class declaration. This is done in two steps. First, within the class body, declare the method prototypes, i.e., whether it is a function or task, any qualifiers (**local**, **protected**, or **virtual**), and the full argument specification plus the **extern** qualifier. The **extern** qualifier indicates that the body of the method (its implementation) is to be found outside the declaration. Second, outside the class declaration, declare the full method (e.g., the prototype but without the qualifiers), and, to tie the method back to its class, qualify the method name with the class name and a pair of colons:

```
class Packet;  
    Packet next;  
    function Packet get_next(); // single line  
        get_next = next;  
    endfunction  
  
    // out-of-body (extern) declaration  
    extern protected virtual function int send(int value);  
endclass  
  
function int Packet::send(int value);  
    // dropped protected virtual, added Packet::  
    // body of method  
    ...  
endfunction
```

The out-of-block method declaration shall match the prototype declaration exactly; the only syntactical difference is that the method name is preceded by the class name and the class scope resolution operator `::`.

An out-of-block declaration shall be declared in the same scope as the class declaration and shall follow the class declaration. It shall be an error if more than one out-of-block declaration is provided for a particular **extern** method.

The class resolution operator is required in some situations in order to name the return type of a method with an out-of-block declaration. When the return type of the out-of-block declaration is defined within the class, the scope resolution operator shall be used to indicate the internal return type.

Example:

```
typedef real T;  
  
class C;  
    typedef int T;  
    extern function T f();  
    extern function real f2();  
endclass
```

```

function C::T C::f(); // the return must use the scope resolution
                        // since the type is defined within the class
    return 1;
endfunction

function real C::f2();
    return 1.0;
endfunction

```

An out-of-block method declaration shall be able to access all declarations of the class in which the corresponding prototype is declared. Following normal resolution rules, the prototype has access to class types only if they are declared prior to the prototype. It shall be an error if an identifier referenced in the prototype does not resolve to the same declaration as the declaration resolved for the corresponding identifier in the out-of-block method declaration's header.

Example:

```

typedef int T;
class C;
    extern function void f(T x);
    typedef real T;
endclass

function void C::f(T x);
endfunction

```

In this example, identifier `T` in the prototype for method `f` resolves to the declaration of `T` in the outer scope. In the out-of-block declaration for method `f` the identifier `T` resolves to `C::T` since the out-of-block declaration has visibility to all types in class `C`. Since the resolution of `T` in the out-of-block declaration does not match the resolution in the prototype, an error shall be reported.

8.24 Parameterized classes

It is often useful to define a generic class whose objects can be instantiated to have different array sizes or data types. This avoids writing similar code for each size or type and allows a single specification to be used for objects that are fundamentally different and (like a templated class in C++) not interchangeable.

The SystemVerilog parameter mechanism is used to parameterize a class:

```

class vector #(int size = 1);
    bit [size-1:0] a;
endclass

```

Instances of this class can then be instantiated like modules or interfaces:

```

vector #(10) vten; // object with vector of size 10
vector #(.size(2)) vtwo; // object with vector of size 2
typedef vector#(4) Vfour; // Class with vector of size 4

```

This feature is particularly useful when using types as parameters:

```

class stack #(type T = int);
    local T items[];
    task push( T a ); ... endtask

```



```

    task pop( ref T a ); ... endtask
  endclass

```

The above class defines a generic *stack* class, which can be instantiated with any arbitrary type:

```

stack is;                // default: a stack of int's
stack#(bit[1:10]) bs;   // a stack of 10-bit vector
stack#(real) rs;       // a stack of real numbers

```

Any type can be supplied as a parameter, including a user-defined type such as a **class** or **struct**.

The combination of a generic class and the actual parameter values is called a *specialization*. Each specialization of a class has a separate set of **static** member variables (this is consistent with C++ templated classes). To share static member variables among several class specializations, they shall be placed in a non-parameterized base class.

```

class vector #(int size = 1);
  bit [size-1:0] a;
  static int count = 0;
  function void disp_count();
    $display( "count: %d of size %d", count, size );
  endfunction
endclass

```

The variable `count` in the example above can only be accessed by the corresponding `disp_count` method. Each specialization of the class *vector* has its own unique copy of `count`.

A specialization is the combination of a specific generic class with a unique set of parameters. Two sets of parameters shall be unique unless all parameters are the same as defined by the following rules:

- a) A parameter is a type parameter and the two types are matching types.
- b) A parameter is a value parameter and both their type and their value are the same.

All matching specializations of a particular generic class shall represent the same type. The set of matching specializations of a generic class is defined by the context of the class declaration. Because generic classes in a package are visible throughout the system, all matching specializations of a package generic class are the same type. In other contexts, such as modules or programs, each instance of the scope containing the generic class declaration creates a unique generic class, thus defining a new set of matching specializations.

A generic class is not a type; only a concrete specialization represents a type. In the example above, the class *vector* becomes a concrete type only when it has had parameters applied to it, for example:

```

typedef vector my_vector; // use default size of 1
vector#(6) vx;           // use size 6

```

To avoid having to repeat the specialization either in the declaration or to create parameters of that type, a **typedef** should be used:

```

typedef vector#(4) Vfour;
typedef stack#(Vfour) Stack4;
Stack4 s1, s2; // declare objects of type Stack4

```

A parameterized class can extend another parameterized class. For example:

```

class C #(type T = bit); ... endclass // base class
class D1 #(type P = real) extends C; // T is bit (the default)

```

```

class D2 #(type P = real) extends C #(integer); // T is integer
class D3 #(type P = real) extends C #(P); // T is P
class D4 #(type P = C#(real)) extends P; // for default T is real

```

Class D1 extends the base class C using the base class's default type (**bit**) parameter. Class D2 extends the base class C using an **integer** parameter. Class D3 extends the base class C using the parameterized type (P) with which the extended class is parameterized. Class D4 extends the base class specified by the type parameter P.

When a type parameter or typedef name is used as a base class, as in class D4 above, the name shall resolve to a class type after elaboration.

The default specialization of a parameterized class is the specialization of the parameterized class with an empty parameter override list. For a parameterized class C, the default specialization is C#(). Other than as the prefix of the scope resolution operator, use of the unadorned name of a parameterized class shall denote the default specialization of the class. Not all parameterized classes have a default specialization since it is legal for a class to not provide parameter defaults. In that case all specializations shall override at least those parameters with no defaults.

Example:

```

class C #(int p = 1);
...
endclass
class D #(int p);
...
endclass

C obj; // legal; equivalent to "C#() obj";
D obj; // illegal; D has no default specialization

```

8.24.1 Class resolution operator for parameterized classes

Use of the class resolution operator with a prefix that is the unadorned name of a parameterized class (see [8.24](#)) shall be restricted to use within the scope of the named parameterized class and within its out-of-block declarations (see [8.23](#)). In such cases, the unadorned name of the parameterized class does not denote the default specialization but is used to unambiguously refer to members of the parameterized class. When referring to the default specialization as the prefix to the class resolution operator, the explicit default specialization form of #() shall be used.

Outside the context of a parameterized class or its out-of-block declarations, the class resolution operator may be used to access any of the class parameters. In such a context, the explicit specialization form shall be used; the unadorned name of the parameterized class shall be illegal. The explicit specialization form may denote a specific parameter or the default specialization form. The class resolution operator may access value as well as type parameters that are either local or parameters to the class.

Example:

```

class C #(int p = 1);
  parameter int q = 5; // local parameter
  static task t;
  int p;
  int x = C::p; // C::p disambiguates p
               // C::p is not p in the default specialization
  endtask
endclass

```

```

int x = C::p;           // illegal; C:: is not permitted in this context
int y = C#()::p;       // legal; refers to parameter p in the default
                        // specialization of C
typedef C T;           // T is a default specialization, not an alias to
                        // the name "C"
int z = T::p;          // legal; T::p refers to p in the default specialization
int v = C#(3)::p;      // legal; parameter p in the specialization of C#(3)
int w = C#()::q;       // legal; refers to the local parameter
T obj = new();
int u = obj.q;         // legal; refers to the local parameter
bit arr[obj.q];        // illegal: local parameter is not a constant expression

```

In the context of a parameterized class method out-of-block declaration, use of the class scope resolution operator shall be a reference to the name as though it was made inside the parameterized class; no specialization is implied.

Example:

```

class C #(int p = 1, type T = int);
    extern static function T f();
endclass

function C::T C::f();
    return p + C::p;
endfunction

initial $display("%0d %0d", C#()::f(),C#(5)::f()); // output is "2 10"

```

8.25 Typedef class

Sometimes a class variable needs to be declared before the class itself has been declared. For example, if two classes each need a handle to the other. When, in the course of processing the declaration for the first class, the compiler encounters the reference to the second class, that reference is undefined and the compiler flags it as an error.

This is resolved using **typedef** to provide a forward declaration for the second class:

```

typedef class C2;       // C2 is declared to be of type class
class C1;
    C2 c;
endclass
class C2;
    C1 c;
endclass

```

In this example, C2 is declared to be of type **class**, a fact that is reinforced later in the source code. The **class** construct always creates a type and does not require a **typedef** declaration for that purpose (as in **typedef class ...**).

In the preceding example, the **class** keyword in the statement **typedef class C2;** is not necessary and is used only for documentation purposes. The statement **typedef C2;** is equivalent and shall work the same way.

As with other forward typedefs as described in [6.18](#), the actual class definition of a forward class declaration shall be resolved within the same local scope or generate block.

A forward **typedef** to a class may refer to a class with a parameter port list.

Example:

```

typedef class C ;
module top ;
    C#(1, real) v2 ;           // positional parameter override
    C#(.p(2), .T(real)) v3 ; // named parameter override
endmodule

class C #(parameter p = 2, type T = int);
endclass

```

8.26 Classes and structures

On the surface, it might appear that **class** and **struct** provide equivalent functionality, and only one of them is needed. However, that is not true; **class** differs from **struct** in the following three fundamental ways:

- a) SystemVerilog structs are strictly static objects; they are created either in a static memory location (global or module scope) or on the stack of an automatic task. Conversely, SystemVerilog objects (i.e., class instances) are exclusively dynamic; their declaration does not create the object. Creating an object is done by calling **new**.
- b) SystemVerilog objects are implemented using handles, thereby providing C-like pointer functionality. But, SystemVerilog disallows casting handles onto other data types; thus, SystemVerilog handles do not have the risks associated with C pointers.
- c) SystemVerilog objects form the basis of an Object-Oriented data abstraction that provides true polymorphism. Class inheritance, abstract classes, and dynamic casting are powerful mechanisms, which go way beyond the mere encapsulation mechanism provided by structs.

8.27 Memory management

Memory for objects, strings, and dynamic and associative arrays is allocated dynamically. When objects are created, SystemVerilog allocates more memory. When an object is no longer needed, SystemVerilog automatically reclaims the memory, making it available for reuse. The automatic memory management system is an integral part of SystemVerilog. Without automatic memory management, SystemVerilog's multi-threaded, reentrant environment creates many opportunities for users to run into problems. A manual memory management system, such as the one provided by C's `malloc` and `free`, would not be sufficient.

For example, consider the following example:

```

myClass obj = new;
fork
    task1 ( obj );
    task2 ( obj );
join_none

```

In this example, the main process (the one that forks off the two tasks) does not know when the two processes might be done using the object `obj`. Similarly, neither `task1` nor `task2` knows when any of the other two processes will no longer be using the object `obj`. It is evident from this simple example that no single process has enough information to determine when it is safe to free the object. The only two options available to the user are as follows:

- Play it safe and never reclaim the object, or

- Add some form of reference count that can be used to determine when it might be safe to reclaim the object.

Adopting the first option can cause the system to quickly run out of memory. The second option places a large burden on users, who, in addition to managing their testbench, must also manage the memory using less than ideal schemes. To avoid these shortcomings, SystemVerilog manages all dynamic memory automatically. Users do not need to worry about dangling references, premature deallocation, or memory leaks. The system shall automatically reclaim any object that is no longer being used. In the example above, all that users do is assign `null` to the handle `obj` when they no longer need it. Similarly, when an object goes out of scope, the system implicitly assigns `null` to the object.

9. Processes

9.1 General

This clause describes the following:

- Structured procedures (initial procedures, always procedures, final procedures)
- Block statements (begin-end sequential blocks, fork-join parallel blocks)
- Timing control (delays, events, waits, intra-assignment)
- Process threads and process control

9.2 Structured procedures

All structured procedures in SystemVerilog are specified within one of the following constructs:

- *initial* procedure, denoted with the keyword **initial** (see [9.2.1](#))
- *always* procedure, denoted with the keywords:
 - **always** (see [9.2.2.1](#))
 - **always_comb** (see [9.2.2.2](#))
 - **always_latch** (see [9.2.2.3](#))
 - **always_ff** (see [9.2.2.4](#))
- *final* procedure, denoted with the keyword **final** (see [9.2.3](#))
- Task
- Function

The syntax for these structured procedures is shown in [Syntax 9-1](#).

```

initial_construct ::= initial statement_or_null // from A.6.2
always_construct ::= always_keyword statement
always_keyword ::= always | always_comb | always_latch | always_ff
final_construct ::= final function_statement
function_declaration ::= function [ lifetime ] function_body_declaration // from A.2.6
task_declaration ::= task [ lifetime ] task_body_declaration // from A.2.7

```

Syntax 9-1—Syntax for structured procedures (excerpt from [Annex A](#))

The initial and always procedures are enabled at the beginning of a simulation. The initial procedure shall execute only once, and its activity shall cease when the statement has finished. In contrast, an always procedure shall execute repeatedly, and its activity shall cease only when the simulation is terminated.

There shall be no implied order of execution between initial and always procedures. The initial procedures need not be scheduled and executed before the always procedures. There shall be no limit to the number of initial and always procedures that can be defined in a module. See [6.8](#) for the order of variable initialization relative to the execution of procedures.

The final procedures are enabled at the end of simulation time and execute only once.

Tasks and functions are procedures that are enabled from one or more places in other procedures. Tasks and functions are described in [Clause 13](#).

In addition to these structured procedures, SystemVerilog contains other procedural contexts, such as coverage point expressions ([19.5](#)), assertion sequence match items ([16.10](#), [16.11](#)) and action blocks ([16.15](#)).

SystemVerilog has the following types of control flow within a procedure:

- Selection, loops, and jumps (see [Clause 12](#))
- Subroutine calls (see [Clause 13](#))
- Sequential and parallel blocks (see [9.3](#))
- Timing control (see [9.4](#))
- Process control (see [9.5](#) through [9.7](#))

9.2.1 Initial procedures

An **initial** procedure shall execute only once, and its activity shall cease when the statement has finished.

The following example illustrates use of an initial procedure for initialization of variables at the start of simulation.

```
initial begin
  a = 0;           // initialize a
  for (int index = 0; index < size; index++)
    memory[index] = 0; // initialize memory word
end
```

Another typical usage of the initial procedure is specification of waveform descriptions that execute once to provide stimulus to the main part of the circuit being simulated.

```
initial begin
  inputs = 'b000000; // initialize at time zero
  #10 inputs = 'b011001; // first pattern
  #10 inputs = 'b011011; // second pattern
  #10 inputs = 'b011000; // third pattern
  #10 inputs = 'b001000; // last pattern
end
```

9.2.2 Always procedures

There are four forms of always procedures: **always**, **always_comb**, **always_latch**, and **always_ff**. All forms of always procedures repeat continuously throughout the duration of the simulation.

9.2.2.1 General purpose always procedure

The **always** keyword represents a general purpose always procedure, which can be used to represent repetitive behavior such as clock oscillators. The construct can also be used with proper timing controls to represent combinational, latched, and sequential hardware behavior.

The general purpose **always** procedure, because of its looping nature, is only useful when used in conjunction with some form of timing control. If an **always** procedure has no control for simulation time to advance, it will create a simulation deadlock condition.

The following code, for example, creates a zero-delay infinite loop:

```
always areg = ~areg;
```

Providing a timing control to the above code creates a potentially useful description as shown in the following:

```
always #half_period areg = ~areg;
```

9.2.2.2 Combinational logic `always_comb` procedure

SystemVerilog provides a special `always_comb` procedure for modeling combinational logic behavior. For example:

```
always_comb
  a = b & c;

always_comb
  d <= #1ns b & c;
```

The `always_comb` procedure provides functionality that is different from the general purpose `always` procedure:

- There is an inferred sensitivity list that includes the expressions defined in [9.2.2.2.1](#).
- The variables written on the left-hand side of assignments shall not be written to by any other process. However, multiple assignments made to independent elements of a variable are allowed as long as their longest static prefixes do not overlap (see [11.5.3](#)). For example, an unpacked structure or array can have one bit assigned by an `always_comb` procedure and another bit assigned continuously or by another `always_comb` procedure, etc. See [6.5](#) for more details.
- The procedure is automatically triggered once at time zero, after all `initial` and `always` procedures have been started so that the outputs of the procedure are consistent with the inputs.

Software tools should perform additional checks to warn if the behavior within an `always_comb` procedure does not represent combinational logic, such as if latched behavior can be inferred.

9.2.2.2.1 Implicit `always_comb` sensitivities

The implicit sensitivity list of an `always_comb` includes the expansions of the longest static prefix of each variable or select expression that is read within the block or within any function called within the block with the following exceptions:

- a) Any expansion of a variable declared within the block or within any function called within the block
- b) Any expression that is also written within the block or within any function called within the block

For the definition of the longest static prefix, see [11.5.3](#).

Hierarchical function calls and function calls from packages are analyzed as normal functions. References to class objects and method calls of class objects do not add anything to the sensitivity list of an `always_comb`.

9.2.2.2.2 `always_comb` compared to `always @*`

The SystemVerilog `always_comb` procedure differs from `always @*` (see [9.4.2.2](#)) in the following ways:

- `always_comb` automatically executes once at time zero, whereas `always @*` waits until a change occurs on a signal in the inferred sensitivity list.
- `always_comb` is sensitive to changes within the contents of a function, whereas `always @*` is only sensitive to changes to the arguments of a function.

- Variables on the left-hand side of assignments within an **always_comb** procedure, including variables from the contents of a called function, shall not be written to by any other processes, whereas **always @*** permits multiple processes to write to the same variable.
- Statements in an **always_comb** shall not include those that block, have blocking timing or event controls, or fork-join statements.

9.2.2.3 Latched logic **always_latch** procedure

SystemVerilog also provides a special **always_latch** procedure for modeling latched logic behavior. For example:

```
always_latch  
  if(ck) q <= d;
```

The **always_latch** construct is identical to the **always_comb** construct except that software tools should perform additional checks and warn if the behavior in an **always_latch** construct does not represent latched logic, whereas in an **always_comb** construct, tools should check and warn if the behavior does not represent combinational logic. All statements in [9.2.2.2](#) shall apply to **always_latch**.

9.2.2.4 Sequential logic **always_ff** procedure

The **always_ff** procedure can be used to model synthesizable sequential logic behavior. For example:

```
always_ff @(posedge clock iff reset == 0 or posedge reset) begin  
  r1 <= reset ? 0 : r2 + 1;  
  ...  
end
```

The **always_ff** procedure imposes the restriction that it contains one and only one event control and no blocking timing controls. Variables on the left-hand side of assignments within an **always_ff** procedure, including variables from the contents of a called function, shall not be written to by any other process.

Software tools should perform additional checks to warn if the behavior within an **always_ff** procedure does not represent sequential logic.

9.2.3 Final procedures

The **final** procedure is like an **initial** procedure, defining a procedural block of statements, except that it occurs at the end of simulation time and executes without delays. A **final** procedure is typically used to display statistical information about the simulation.

The only statements allowed inside a **final** procedure are those permitted inside a function declaration, so that they execute within a single simulation cycle. Unlike an **initial** procedure, the **final** procedure does not execute as a separate process; instead, it executes in zero time, as a series of function calls from a single process. All **final** procedures shall execute in an arbitrary order. No remaining scheduled events shall execute after all final procedures have executed.

A **final** procedure executes when simulation ends due to an explicit or implicit call to `$finish`.

```
final  
  begin  
    $display("Number of cycles executed %d", $time/period);  
    $display("Final PC = %h", PC);  
  end
```

Execution of `$finish`, `tf_dofinish()`, or `vpi_control(vpiFinish,...)` from within a **final** procedure shall cause the simulation to end immediately. A **final** procedure can only trigger once in a simulation.

A **final** procedure shall execute before any PLI callbacks that indicate the end of simulation.

SystemVerilog **final** procedures execute in an arbitrary but deterministic sequential order. This is possible because **final** procedures are limited to the legal set of statements allowed for functions.

NOTE—SystemVerilog does not specify the ordering in which final procedures are executed, but implementations should define rules that preserve the ordering between runs. This helps keep the output log file stable because **final** procedures are mainly used for displaying statistics.

9.3 Block statements

Block statements are a means of grouping statements together so that they act syntactically like a single statement. There are two types of blocks, as follows:

- *Sequential block*, also called *begin-end block*
- *Parallel block*, also called *fork-join block*

The sequential block shall be delimited by the keywords **begin** and **end**. The procedural statements in a sequential block shall be executed sequentially in the given order.

The parallel block shall be delimited by the keywords **fork** and **join**, **join_any**, or **join_none**. The procedural statements in a parallel block shall be executed concurrently.

9.3.1 Sequential blocks

A *sequential block* shall have the following characteristics:

- Statements shall be executed in sequence, one after another.
- Delay values for each statement shall be treated relative to the simulation time of the execution of the previous statement.
- Control shall pass out of the block after the last statement executes.

[Syntax 9-2](#) gives the formal syntax for a sequential block.

```
seq_block ::= // from A.6.3
  begin [ : block_identifier ] { block_item_declaration } { statement_or_null }
  end [ : block_identifier ]

block_item_declaration ::= // from A.2.8
  { attribute_instance } data_declaration
  | { attribute_instance } local_parameter_declaration ;
  | { attribute_instance } parameter_declaration ;
  | { attribute_instance } overload_declaration
  | { attribute_instance } let_declaration
```

Syntax 9-2—Syntax for sequential block (excerpt from [Annex A](#))

Example 1—A sequential block enables the following two assignments to have a deterministic result:

```
begin
  areg = breg;
```

```
    creg = areg;      // creg stores the value of breg
end
```

The first assignment is performed, and areg is updated before control passes to the second assignment.

Example 2—An event control (see [9.4.2](#)) can be used in a sequential block to separate the two assignments in time.

```
begin
    areg = breg;
    @(posedge clock) creg = areg; // assignment delayed until
end                               // posedge on clock
```

Example 3—The following example shows how the combination of the sequential block and delay control can be used to specify a time-sequenced waveform:

```
parameter d = 50; // d declared as a parameter and
logic [7:0] r;    // r declared as an 8-bit variable

begin // a waveform controlled by sequential delays
    #d r = 'h35;
    #d r = 'hE2;
    #d r = 'h00;
    #d r = 'hF7;
end
```

9.3.2 Parallel blocks

The fork-join *parallel block* construct enables the creation of concurrent processes from each of its parallel statements. A parallel block shall have the following characteristics:

- Statements shall execute concurrently.
- Delay values for each statement shall be considered relative to the simulation time of entering the block.
- Delay control can be used to provide time-ordering for assignments.
- Control shall pass out of the block when the last time-ordered statement executes based on the type of join keyword.
- Has restricted usage inside function calls (see [13.4](#)).

[Syntax 9-3](#) gives the formal syntax for a parallel block.

```
par_block ::=                                                                    //from 4.6.3
    fork [ : block_identifier ] { block_item_declaration } { statement_or_null }
    join_keyword [ : block_identifier ]
join_keyword ::= join | join_any | join_none
block_item_declaration ::=                                                       //from 4.2.8
    { attribute_instance } data_declaration
    | { attribute_instance } local_parameter_declaration ;
    | { attribute_instance } parameter_declaration ;
    | { attribute_instance } overload_declaration
    | { attribute_instance } let_declaration
```

Syntax 9-3—Syntax for parallel block (excerpt from [Annex A](#))

One or more statements can be specified; each statement shall execute as a concurrent process. The timing controls in a fork-join block do not have to be ordered sequentially in time.

The following example codes the waveform description shown in Example 3 of 9.3.1 by using a parallel block instead of a sequential block. The waveform produced on the variable is exactly the same for both implementations.

```
fork
  #50 r = 'h35;
  #100 r = 'hE2;
  #150 r = 'h00;
  #200 r = 'hF7;
join
```

SystemVerilog provides three choices for specifying when the parent (forking) process resumes execution, which are summarized in Table 9-1.

Table 9-1—fork-join control options

Option	Description
join	The parent process blocks until all the processes spawned by this fork complete.
join_any	The parent process blocks until any one of the processes spawned by this fork completes.
join_none	The parent process continues to execute concurrently with all the processes spawned by the fork. The spawned processes do not start executing until the parent thread executes a blocking statement.

When defining a fork-join block, encapsulating the entire fork within a begin-end block causes the entire block to execute as a single process, with each statement executing sequentially.

```
fork
  begin
    statement1; // one process with 2 statements
    statement2;
  end
join
```

In the following example, two processes are forked. The first one waits for 20 ns and the second one waits for the named event `eventA` to be triggered. Because the `join` keyword is specified, the parent process shall block until the two processes complete, i.e., until 20 ns have elapsed and `eventA` has been triggered.

```
fork
  begin
    $display( "First Block\n" );
    # 20ns;
  end
  begin
    $display( "Second Block\n" );
    @eventA;
  end
join
```

A `return` statement within the context of a fork-join block is illegal and shall result in a compilation error. For example:

```
task wait_20;  
  fork  
    # 20;  
    return ;    // Illegal: cannot return; task lives in another process  
  join_none  
endtask
```

Variables declared in the *block_item_declaration* of a fork-join block shall be initialized to their initialization value expression whenever execution enters their scope and before any processes are spawned. Within a **fork-join_any** or **fork-join_none** block, it shall be illegal to refer to formal arguments passed by reference other than in the initialization value expressions of variables declared in a *block_item_declaration* of the fork. These variables are useful in processes spawned by looping constructs to store unique, per-iteration data. For example:

```
initial  
  for( int j = 1; j <= 3; ++j )  
    fork  
      automatic int k = j; // local copy, k, for each value of j  
      #k $write( "%0d", k );  
      begin  
        automatic int m = j; // the value of m is undetermined  
        ...  
      end  
    join_none
```

The example above generates the output 123.

9.3.3 Statement block start and finish times

Both sequential and parallel blocks have the notion of a start and finish time. For sequential blocks, the start time is when the first statement is executed, and the finish time is when the last statement has been executed. For parallel blocks, the start time is the same for all the statements, and the finish time is controlled by the type of join construct used (see [9.3.2](#), [Table 9-1](#)).

Sequential and parallel blocks can be embedded within each other, allowing complex control structures to be expressed easily and with a high degree of structure. When blocks are embedded within each other, the timing of when a block starts and finishes is important. Execution shall not continue to the statement following a block until the finish time for the block has been reached, that is, until the block has completely finished executing.

Example 1—The following example shows the statements from the example in [9.3.2](#) written in the reverse order and still producing the same waveform.

```
fork  
  #200 r = 'hF7;  
  #150 r = 'h00;  
  #100 r = 'hE2;  
  #50 r = 'h35;  
join
```

Example 2—When an assignment is to be made after two separate events have occurred, known as the *joining of events*, a **fork-join** block can be useful.

```
begin  
  fork  
    @Aevent;
```

```

        @Bevent;
    join
    areg = breg;
end

```

The two events can occur in any order (or even at the same simulation time), the **fork-join** block will complete once both events have occurred, and the assignment will be made. In contrast, if the **fork-join** block was a **begin-end** block and the `Bevent` occurred before the `Aevent`, then the block would be waiting for the next `Bevent`.

Example 3—This example shows two sequential blocks, each of which will execute when its controlling event occurs. Because the event controls are within a **fork-join** block, they execute in parallel, and the sequential blocks can, therefore, also execute in parallel.

```

fork
  @enable_a
  begin
    #ta wa = 0;
    #ta wa = 1;
    #ta wa = 0;
  end
  @enable_b
  begin
    #tb wb = 1;
    #tb wb = 0;
    #tb wb = 1;
  end
end
join

```

9.3.4 Block names

Both sequential and parallel blocks can be named by adding `: name_of_block` after the keywords **begin** or **fork**. A named block creates a new hierarchy scope. The naming of blocks serves the following purposes:

- It allows local variables, parameters, and named events to be referenced hierarchically, using the block name.
- It allows the block to be referenced in statements such as the **disable** statement (see [9.6.2](#)).

An unnamed block creates a new hierarchy scope only if it directly contains a block item declaration, such as a variable declaration or a type declaration. This hierarchy scope is unnamed and the items declared in it cannot be hierarchically referenced (see [6.21](#)).

All variables shall be static; that is, a unique location exists for all variables, and leaving or entering blocks shall not affect the values stored in them.

The block names give a means of uniquely identifying all variables at any simulation time.

A matching block name may be specified after the block **end**, **join**, **join_any**, or **join_none** keyword, preceded by a colon. This can help document which **end** or **join**, **join_any**, or **join_none** is associated with which **begin** or **fork** when there are nested blocks. A name at the end of the block is not required. It shall be an error if the name at the end is different from the block name at the beginning.

```

begin: blockB    // block name after the begin or fork
...
end: blockB

```

Similarly, a matching block name may be specified after the following block end keywords, preceded by a colon:

- **endchecker** (see [17.2](#))
- **endclass** (see [8.3](#))
- **endclocking** (see [14.3](#))
- **endconfig** (see [33.4](#))
- **endfunction** (see [13.4](#))
- **endgroup** (see [19.2](#))
- **endinterface** (see [25.3](#))
- **endmodule** (see [23.2.1](#))
- **endpackage** (see [26.2](#))
- **endprimitive** (see [29.3](#))
- **endprogram** (see [24.3](#))
- **endproperty** (see [16.2](#))
- **endsequence** (see [16.8](#))
- **endtask** (see [13.3](#))

A matching block name may also follow the keyword **end** at the end of a generate block (see [27.3](#)). A name at the end of the block is not required. It shall be an error if the name at the end is different from the block name at the beginning.

9.3.5 Statement labels

A label can be specified before any procedural statement (any non-declaration statement that can appear inside a begin-end block), as in C. A statement label is used to identify a single statement. The label name is specified before the statement, followed by a colon.

```
labelA: statement
```

A begin-end or fork-join block is considered a statement, and can have a statement label before the block. Specifying a statement label before a **begin** or **fork** keyword is equivalent to specifying a block name after the keyword, and a matching block name may be specified after the block **end**, **join**, **join_any**, or **join_none** keyword. For example:

```
labelB: fork    // label before the begin or fork
...
join_none : labelB
```

It shall be illegal to have both a label before a **begin** or **fork** and a block name after the **begin** or **fork**. A label cannot appear before the **end**, **join**, **join_any**, or **join_none**, as these keywords do not form a statement.

A statement label on a **foreach** loop, or on a **for** loop with variables declared as part of the **for_initialization**, names the implicit block created by the loop. For other types of statements, a statement label creates a named begin-end block around the statement and creates a new hierarchy scope.

A label may also be specified before a generate begin-end block (see [27.3](#)).

A label may also be specified before a concurrent assertion (see [16.5](#)).

A statement with a label can be disabled using a **disable** statement. Disabling a statement shall have the same behavior as disabling a named block. See [9.6.2](#) on disable statements and process control.

9.4 Procedural timing controls

SystemVerilog has two types of explicit timing control over when procedural statements can occur. The first type is a *delay control*, in which an expression specifies the time duration between initially encountering the statement and when the statement actually executes. The delay expression can be a dynamic function of the state of the circuit, but it can be a simple number that separates statement executions in time. The delay control is an important feature when specifying stimulus waveform descriptions. It is described in [9.4.1](#) and [9.4.5](#).

The second type of timing control is the *event expression*, which allows statement execution to be delayed until the occurrence of some simulation event occurring in a procedure executing concurrently with this procedure. A simulation event can be a change of value on a net or variable (an *implicit event*) or the occurrence of an explicitly named event that is triggered from other procedures (an *explicit event*). Most often, an event control is a positive or negative edge on a clock signal. Event control is discussed in [9.4.2](#) through [9.4.5](#).

The procedural statements encountered so far all execute without advancing simulation time. Simulation time can advance by one of the following three methods:

- A *delay control*, which is introduced by the symbol #
- An *event control*, which is introduced by the symbol @
- The *wait* statement, which operates like a combination of the event control and the while loop

The three procedural timing control methods are discussed in [9.4.1](#) through [9.4.5](#). [Syntax 9-4](#) shows the syntax of timing control in procedural statements.

```

procedural_timing_control_statement ::=                                     //from 4.6.5
    procedural_timing_control_statement_or_null
delay_or_event_control ::=
    delay_control
    | event_control
    | repeat ( expression ) event_control
delay_control ::=
    # delay_value
    | # ( mintypmax_expression )
event_control ::=
    @ hierarchical_event_identifier
    | @ ( event_expression )
    | @*
    | @ ( * )
    | @ ps_or_hierarchical_sequence_identifier
event_expression27 ::=
    [ edge_identifier ] expression [ iff expression ]
    | sequence_instance [ iff expression ]
    | event_expression or event_expression
    | event_expression , event_expression
    | ( event_expression )
procedural_timing_control ::=
    delay_control

```



```

| event_control
| cycle_delay
...
wait_statement ::=
    wait ( expression ) statement_or_null
| wait fork ;
| wait_order ( hierarchical_identifier { , hierarchical_identifier } ) action_block
edge_identifier ::= posedge | negedge | edge //from A.7.4

```

27) Parentheses are required when an event expression that contains comma-separated event expressions is passed as an actual argument using positional binding.

Syntax 9-4—Delay and event control syntax (excerpt from Annex A)

The gate and net delays also advance simulation time, as discussed in [Clause 28](#).

9.4.1 Delay control

A procedural statement following the delay control shall be delayed in its execution with respect to the procedural statement preceding the delay control by the specified delay. If the delay expression evaluates to an unknown or high-impedance value, it shall be interpreted as zero delay. If the delay expression evaluates to a negative value, it shall be interpreted as a two's-complement unsigned integer of the same size as a time variable. Specify parameters are permitted in the delay expression. They can be overridden by SDF annotation, in which case the expression is reevaluated.

Example 1—The following example delays the execution of the assignment by 10 time units:

```
#10 rega = regb;
```

Example 2—The next three examples provide an expression following the number sign (#). Execution of the assignment is delayed by the amount of simulation time specified by the value of the expression.

```
#d rega = regb;           // d is defined as a parameter
#((d+e)/2) rega = regb;  // delay is average of d and e
#regr regr = regr + 1;   // delay is the value in regr
```

9.4.2 Event control

The execution of a procedural statement can be synchronized with a value change on a net or variable or the occurrence of a declared event. The value changes on nets and variables can be used as events to trigger the execution of a statement. This is known as *detecting an implicit event*. The event can also be based on the direction of the change, that is, toward the value 1 (**posedge**) or toward the value 0 (**negedge**). The behavior of posedge and negedge events is shown in [Table 9-2](#) and can be described as follows:

- A *negedge* shall be detected on the transition from 1 to x, z, or 0, and from x or z to 0
- A *posedge* shall be detected on the transition from 0 to x, z, or 1, and from x or z to 1

Table 9-2—Detecting posedge and negedge

From	To			
	0	1	x	z
0	No edge	posedge	posedge	posedge
1	negedge	No edge	negedge	negedge
x	negedge	posedge	No edge	No edge
z	negedge	posedge	No edge	No edge

In addition to **posedge** and **negedge**, a third edge event, **edge**, indicates a change towards either 1 or 0. More precisely, the behavior of an edge event can be described as:

- An *edge* shall be detected whenever *negedge* or *posedge* is detected.

An implicit event shall be detected on any change in the value of the expression. An edge event shall be detected only on the least significant bit of the expression. A change of value in any operand of the expression without a change in the result of the expression shall not be detected as an event.

The following example shows illustrations of edge-controlled statements:

```
@r rega = regb; // controlled by any value change in the reg r
@(posedge clock) rega = regb; // controlled by posedge on clock
forever @(negedge clock) rega = regb; // controlled by negedge on clock
forever @(edge clock) rega = regb; // controlled by edge on clock
```

If the expression denotes a **clocking** block **input** or **inout** (see [Clause 14](#)), the event control operator uses the synchronous values, that is, the values sampled by the clocking event. The expression can also denote a **clocking** block name (with no edge qualifier) to be triggered by the clocking event.

A variable used with the event control can be any one of the integral data types (see [6.11.1](#)) or string. The variable can be either a simple variable or a **ref** argument (variable passed by reference); it can be a member of an array, associative array, or object (class instance) of the aforementioned types.

Event expressions shall return singular values. Aggregate types can be used in an expression provided the expression reduces to a singular value. The object members or aggregate elements can be any type as long as the result of the expression is a singular value.

If the event expression is a reference to a simple object handle or handle variable, an event is created when a write to that variable is not equal to its previous value.

Nonvirtual methods of an object and built-in methods or system functions for an aggregate type are allowed in event control expressions as long as the type of the return value is singular and the method is defined as a function, not a task.

Changing the value of object data members, aggregate elements, or the size of a dynamically sized array referenced by a method or function shall cause the event expression to be reevaluated. An implementation can cause the event expression to be reevaluated when changing the value or size even if the members are not referenced by the method or function.

```

real AOR[]; // dynamic array of reals
byte stream[$]; // queue of bytes
initial wait(AOR.size() > 0) ....; // waits for array to be allocated
initial wait($bits(stream) > 60)...; // waits for total number of bits
// in stream greater than 60

Packet p = new; // Packet 1 -- Packet is defined in 8.2
Packet q = new; // Packet 2
initial fork
  @(p.status); // Wait for status in Packet 1 to change
  @p; // Wait for a change to handle p
  # 10 p = q; // triggers @p.
  // @(p.status) now waits for status in Packet 2 to change,
  // if not already different from Packet 1
join

```

9.4.2.1 Event or operator

The logical or of any number of events can be expressed so that the occurrence of any one of the events triggers the execution of the procedural statement that follows it. The keyword **or** or a comma character (,) is used as an event logical or operator. A combination of these can be used in the same event expression. Comma-separated sensitivity lists shall be synonymous to **or**-separated sensitivity lists.

The next two examples show the logical or of two and three events, respectively:

```

@(trig or enable) rega = regb; // controlled by trig or enable

@(posedge clk_a or posedge clk_b or trig) rega = regb;

```

The following examples show the use of the comma (,) as an event logical **or** operator:

```

always @(a, b, c, d, e)

always @(posedge clk, negedge rstn)

always @(a or b, c, d or e)

```

9.4.2.2 Implicit event_expression list

An incomplete event_expression list of an event control is a common source of bugs in register transfer level (RTL) simulations. The implicit event_expression, @*, is a convenient shorthand that eliminates these problems by adding all nets and variables that are read by the statement (which can be a statement group) of a *procedural_timing_control_statement* to the *event_expression*.

NOTE—The **always_comb** procedure (see 9.2.2.2) is preferred over using the @* implicit event_expression list when used at the beginning of an always procedure as a sensitivity list. See 9.2.2.2 for a comparison of **always_comb** and @*.

All net and variable identifiers that appear in the statement will be automatically added to the event expression with the following exceptions:

- Identifiers that only appear in wait or event expressions.
- Identifiers that only appear as a *hierarchical_variable_identifier* in the *variable_lvalue* of the left-hand side of assignments.

Nets and variables that appear on the right-hand side of assignments, in subroutine calls, in case and conditional expressions, as an index variable on the left-hand side of assignments, or as variables in case item expressions shall all be included by these rules.

Example 1

```
always @(*) // equivalent to @(a or b or c or d or f)
  y = (a & b) | (c & d) | myfunction(f);
```

Example 2

```
always @* begin // equivalent to @(a or b or c or d or tmp1 or tmp2)
  tmp1 = a & b;
  tmp2 = c & d;
  y = tmp1 | tmp2;
end
```

Example 3

```
always @* begin // equivalent to @(b)
  @(i) kid = b; // i is not added to @*
end
```

Example 4

```
always @* begin // equivalent to @(a or b or c or d)
  x = a ^ b;
  @* // equivalent to @(c or d)
  x = c ^ d;
end
```

Example 5

```
always @* begin // same as @(a or en)
  y = 8'hff;
  y[a] = !en;
end
```

Example 6

```
always @* begin // same as @(state or go or ws)
  next = 4'b0;
  case (1'b1)
    state[IDLE]: if (go) next[READ] = 1'b1;
                 else next[IDLE] = 1'b1;
    state[READ]: next[DLY ] = 1'b1;
    state[DLY ]: if (!ws) next[DONE] = 1'b1;
                 else next[READ] = 1'b1;
    state[DONE]: next[IDLE] = 1'b1;
  endcase
end
```

9.4.2.3 Conditional event controls

The @ event control can have an **iff** qualifier.

```
module latch (output logic [31:0] y, input [31:0] a, input enable);
```

```
always @(a iff enable == 1)
    y <= a; //latch is in transparent mode
endmodule
```

The event expression only triggers if the expression after the **iff** is true, in this case when `enable` is equal to 1. This type of expression is evaluated when `a` changes and not when `enable` changes. Also, in similar event expressions of this type, **iff** has precedence over **or**. This can be made clearer by the use of parentheses.

9.4.2.4 Sequence events

A sequence instance can be used in event expressions to control the execution of procedural statements based on the successful match of the sequence. This allows the end point of a named sequence to trigger multiple actions in other processes. [Syntax 16-3](#) and [Syntax 16-5](#) describe the syntax for declaring named sequences and sequence instances. A sequence instance can be used directly in an event expression, as shown in [Syntax 9-4](#).

When a sequence instance is specified in an event expression, the process executing the event control shall block until the specified sequence reaches its end point. A sequence reaches its end point whenever there is a match for the entire sequence. A process resumes execution following the Observed region in which the end point is detected.

An example of using a sequence as an event control is shown below.

```
sequence abc;
    @(posedge clk) a ##1 b ##1 c;
endsequence

program test;
    initial begin
        @ abc $display( "Saw a-b-c" );
        L1 : ...
    end
endprogram
```

In the example above, when the named sequence `abc` reaches its end point, the **initial** procedure in the program block `test` is unblocked, then displays the string "Saw a-b-c", and continues execution with the statement labeled `L1`. In this case, the end of the sequence acts as the trigger to unblock the event.

A sequence used in an event control is instantiated (as if by an assert property statement); the event control is used to synchronize to the end of the sequence, regardless of its start time. Arguments to these sequences shall be static; automatic variables used as sequence arguments shall result in an error.

9.4.3 Level-sensitive event control

The execution of a procedural statement can also be delayed until a condition becomes true. This is accomplished using the *wait* statement, which is a special form of event control. The nature of the wait statement is level-sensitive, as opposed to basic event control (specified by the `@` character), which is edge-sensitive.

The wait statement shall evaluate a condition; and, if it is false, the procedural statements following the wait statement shall remain blocked until that condition becomes true before continuing. The wait statement has the form given in [Syntax 9-5](#).

```
wait_statement ::= //from A.6.5
    wait ( expression ) statement_or_null
  | wait fork ;
  | wait_order ( hierarchical_identifier { , hierarchical_identifier } ) action_block
```

Syntax 9-5—Syntax for wait statement (excerpt from [Annex A](#))

The following example shows the use of the wait statement to accomplish level-sensitive event control:

```
begin
    wait (!enable) #10 a = b;
    #10 c = d;
end
```

If the value of `enable` is 1 when the block is entered, the wait statement will delay the evaluation of the next statement (`#10 a = b;`) until the value of `enable` changes to 0. If `enable` is already 0 when the begin-end block is entered, then the assignment “`a = b;`” is evaluated after a delay of 10 and no additional delay occurs.

See also [9.6](#) on process control.

9.4.4 Level-sensitive sequence controls

The execution of procedural code can be delayed until a sequence termination status is true. This is accomplished using the level-sensitive `wait` statement in conjunction with the built-in method that returns the current end status of a named sequence: `triggered`.

The `triggered` sequence method evaluates to true if the given sequence has reached its end point at that particular point in time (in the current time step) and false otherwise. The triggered status of a sequence is set during the Observed region and persists through the remainder of the time step (i.e., until simulation time advances).

For example:

```
sequence abc;
    @(posedge clk) a ##1 b ##1 c;
endsequence

sequence de;
    @(negedge clk) d ##[2:5] e;
endsequence

program check;
    initial begin
        wait( abc.triggered || de.triggered );
        if( abc.triggered )
            $display( "abc succeeded" );
        if( de.triggered )
            $display( "de succeeded" );
        L2 : ...
    end
endprogram
```

In the above example, the `initial` procedure in program `check` waits for the end point (success) of either sequence `abc` or sequence `de`. When either condition evaluates to true, the `wait` statement unblocks the process, displays the sequences that caused the process to unblock, and then continues to execute the statement labeled `L2`.

9.4.5 Intra-assignment timing controls

The delay and event control constructs previously described precede a statement and delay its execution. In contrast, *intra-assignment delay and event controls* are contained within an assignment statement and modify the flow of activity in a different way. This subclause describes the purpose of intra-assignment timing controls and the repeat timing control that can be used in intra-assignment delays.

An intra-assignment delay or event control shall delay the assignment of the new value to the left-hand side, but the right-hand expression shall be evaluated before the delay, instead of after the delay. The syntax for intra-assignment delay and event control is given in [Syntax 9-6](#).

```
blocking_assignment ::=                                     //from A.6.2
    variable_lvalue = delay_or_event_control expression
    | ...
nonblocking_assignment ::=
    variable_lvalue <= [ delay_or_event_control ] expression
```

Syntax 9-6—Syntax for intra-assignment delay and event control (excerpt from [Annex A](#))

The `delay_or_event_control` syntax is shown in [Syntax 9-4](#) in [9.4](#).

The intra-assignment delay and event control can be applied to both blocking assignments and nonblocking assignments. The *repeat* event control shall specify an intra-assignment delay of a specified number of occurrences of an event. If the *repeat* count literal, or signed variable holding the *repeat* count, is less than or equal to 0 at the time of evaluation, the assignment occurs as if there is no *repeat* construct.

For example:

```
repeat (3) @ (event_expression)
    // will execute event_expression three times

repeat (-3) @ (event_expression)
    // will not execute event_expression.

repeat (a) @ (event_expression)
    // if a is assigned -3, it will execute the event_expression if a is
    // declared as an unsigned variable, but not if a is signed
```

This construct is convenient when events have to be synchronized with counts of clock signals.

[Table 9-3](#) illustrates the philosophy of intra-assignment timing controls by showing the code that could accomplish the same timing effect without using intra-assignment timing.

Table 9-3—Intra-assignment timing control equivalence

<i>intra-assignment timing control</i>	
With intra-assignment construct	Without intra-assignment construct
<pre>a = #5 b;</pre>	<pre>begin temp = b; #5 a = temp; end</pre>
<pre>a = @(posedge clk) b;</pre>	<pre>begin temp = b; @(posedge clk) a = temp; end</pre>
<pre>a = repeat(3) @(posedge clk) b;</pre>	<pre>begin temp = b; @(posedge clk); @(posedge clk); @(posedge clk) a = temp; end</pre>

The next three examples use the fork-join behavioral construct. All statements between the keywords **fork** and **join** execute concurrently. This construct is described in more detail in [9.3.2](#).

The following example shows a race condition that could be prevented by using intra-assignment timing control:

```
fork
  #5 a = b;
  #5 b = a;
join
```

The code in this example samples and sets the values of both *a* and *b* at the same simulation time, thereby creating a race condition. The intra-assignment form of timing control used in the next example prevents this race condition.

```
fork                                // data swap
  a = #5 b;
  b = #5 a;
join
```

Intra-assignment timing control works because the intra-assignment delay causes the values of *a* and *b* to be evaluated before the delay and causes the assignments to be made after the delay.

Intra-assignment waiting for events is also effective. In the following example, the right-hand expressions are evaluated when the assignment statements are encountered, but the assignments are delayed until the rising edge of the clock signal:

```
fork                                // data shift
  a = @(posedge clk) b;
  b = @(posedge clk) c;
join
```

The following is an example of a repeat event control as the intra-assignment delay of a nonblocking assignment:

```
a <= repeat(5) @(posedge clk) data;
```

Figure 9-1 illustrates the activities that result from this `repeat` event control.

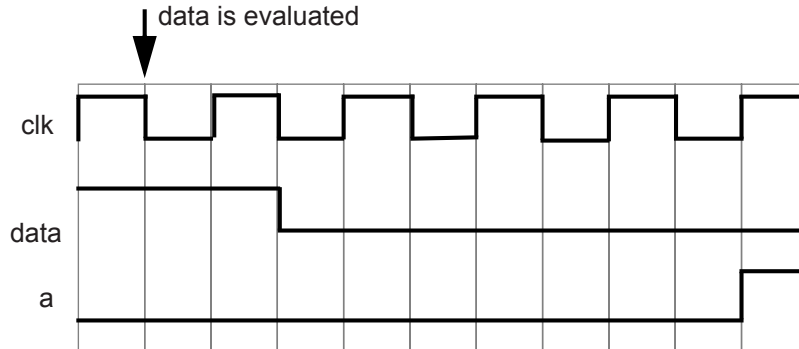

Figure 9-1—Intra-assignment repeat event control utilizing a clock edge

In this example, the value of `data` is evaluated when the assignment is encountered. After five occurrences of `posedge clk`, `a` is assigned the value of `data`.

The following is an example of a repeat event control as the intra-assignment delay of a procedural assignment:

```
a = repeat(num) @(clk) data;
```

In this example, the value of `data` is evaluated when the assignment is encountered. After the number of transitions of `clk` equals the value of `num`, `a` is assigned the value of `data`.

The following is an example of a repeat event control with expressions containing operations to specify both the number of event occurrences and the event that is counted:

```
a <= repeat(a+b) @(posedge phi1 or negedge phi2) data;
```

In this example, the value of `data` is evaluated when the assignment is encountered. After the sum of the positive edges of `phi1` and the negative edges of `phi2` equals the sum of `a` and `b`, `a` is assigned the value of `data`. Even if `posedge phi1` and `negedge phi2` occurred at the same simulation time, each will be detected and counted separately.

If `phi1` and `phi2` refer to the same signal, then the assignment above can be simplified as:

```
a <= repeat(a+b) @(edge phi1) data;
```

9.5 Process execution threads

SystemVerilog creates a thread of execution for the following:

- Each `initial` procedure
- Each `final` procedure
- Each `always`, `always_comb`, `always_latch` and `always_ff` procedure

- Each parallel statement in a **fork-join** (or **join_any** or **join_none**) statement group
- Each dynamic process

Each continuous assignment can also be considered its own thread (see [10.3](#)).

9.6 Process control

SystemVerilog provides constructs that allow one process to terminate or wait for the completion of other processes. The **wait fork** construct waits for the completion of processes. The **disable** construct stops the execution of all activity within a named block or task, without regard to parent-child relationship (a child process can terminate execution of a parent or one process can terminate execution of an unrelated process). The **disable fork** construct stops the execution of processes, but with consideration of parent-child relationships.

The process control statements have the syntax form shown in [Syntax 9-7](#).

```
wait_statement ::= // from A.6.5
    wait ( expression ) statement_or_null
  | wait fork ;
  | wait_order ( hierarchical_identifier { , hierarchical_identifier } ) action_block
disable_statement ::=
    disable hierarchical_task_identifier ;
  | disable hierarchical_block_identifier ;
  | disable fork ;
```

Syntax 9-7—Syntax for process control statements (excerpt from [Annex A](#))

9.6.1 Wait fork statement

The **wait fork** statement blocks process execution flow until all immediate child subprocesses (processes created by the current process, excluding their descendants) have completed their execution.

The syntax for **wait fork** is as follows:

```
wait fork ; // from A.6.5
```

Specifying **wait fork** causes the calling process to block until all its immediate child subprocesses have completed.

Simulation automatically terminates when there is no further activity of any kind. Simulation also automatically terminates when all its program blocks finish executing (i.e, they reach the end of their execute block), regardless of the status of any child processes (see [24.7](#)). The **wait fork** statement allows a program block to wait for the completion of all its concurrent threads before exiting.

In the following example, in the task `do_test`, the first two processes are spawned, and the task blocks until one of the two processes completes (either `exec1` or `exec2`). Next, two more processes are spawned in the background. The **wait fork** statement shall block the execution flow of the task `do_test` until all four spawned processes complete before returning to its caller.

```
task do_test;
  fork
    exec1 ();
```

```
    exec2 ();  
    join_any  
    fork  
        exec3 ();  
        exec4 ();  
    join_none  
    wait fork;           // block until execl ... exec4 complete  
endtask
```

9.6.2 Disable statement

The *disable* statement provides the ability to terminate the activity associated with concurrently active processes, while maintaining the structured nature of procedural descriptions. The disable statement gives a mechanism for terminating a task before it executes all its statements, breaking from a looping statement, or skipping statements in order to continue with another iteration of a looping statement. It is useful for handling exception conditions such as hardware interrupts and global resets. The disable statement can also be used to terminate execution of a labeled statement, including a deferred assertion (see [16.4](#)) or a procedural concurrent assertion (see [16.15.6](#)).

The disable statement shall terminate the activity of a task or a named block. Execution shall resume at the statement following the block or following the task-enabling statement. All activities enabled within the named block or task shall be terminated as well. If task enable statements are nested (that is, one task enables another, and that one enables yet another), then disabling a task within the chain shall disable all tasks downward on the chain. If a task is enabled more than once, then disabling such a task shall disable all activations of the task.

The results of the following activities that can be initiated by a task are not specified if the task is disabled:

- Results of output and inout arguments
- Scheduled, but not executed, nonblocking assignments
- Procedural continuous assignments (assign and force statements)

The disable statement can be used within blocks and tasks to disable the particular block or task containing the disable statement. The disable statement can be used to disable named blocks within a function, but cannot be used to disable functions. In cases where a disable statement within a function disables a block or a task that called the function, the behavior is undefined. Disabling an automatic task or a block inside an automatic task proceeds as for regular tasks for all concurrent executions of the task.

Example 1—This example illustrates how a block disables itself.

```
begin : block_name  
    rega = regb;  
    disable block_name;  
    regc = rega; // this assignment will never execute  
end
```

Example 2—This example shows the disable statement being used within a named block in a manner similar to a forward *goto*. The next statement executed after the disable statement is the one following the named block.

```
begin : block_name  
    ...  
    ...  
    if (a == 0)  
        disable block_name;  
    ...
```

```

end          // end of named block
// continue with code following named block
...

```

Example 3—This example illustrates using the `disable` construct to terminate execution of a named block that does not contain the `disable` statement. If the block is currently executing, this causes control to jump to the statement immediately after the block. If the block is a loop body, it acts like a `continue` (see [12.8](#)). If the block is not currently executing, the `disable` has no effect.

```

module m (...);
  always
    begin : always1
      ...
      t1: task1( ); // task call
      ...
    end
  ...

  always
    begin
      ...
      disable m.always1; // exit always1, which will exit task1,
                        // if it was currently executing
    end
endmodule

```

Example 4—This example shows the `disable` statement being used as an early return from a task. However, a task disabling itself using a `disable` statement is not a shorthand for the `return` statement (see [12.8](#)).

SystemVerilog has `return` from a task, which shall terminate execution of the process in which the return is executed. If `disable` is applied to a task, all currently active executions of the task are disabled.

```

task proc_a;
  begin
    ...
    ...
    if (a == 0)
      disable proc_a; // return if true
    ...
    ...
  end
endtask

```

Example 5—This example shows the `disable` statement being used in an equivalent way to the two statements `continue` and `break` (see [12.8](#)). The example illustrates control code that would allow a named block to execute until a loop counter reaches `n` iterations or until the variable `a` is set to the value of `b`. The named block `outer_block` contains the code that executes until `a == b`, at which point the `disable outer_block;` statement terminates execution of that block. The named block `inner_block` contains the code that executes for each iteration of the `for` loop. Each time this code executes the `disable inner_block;` statement, the `inner_block` block terminates, and execution passes to the next iteration of the `for` loop. For each iteration of the `inner_block` block, a set of statements executes if `(a != 0)`. Another set of statements executes if `(a! = b)`.

```

begin : outer_block
  for (i = 0; i < n; i = i+1) begin : inner_block
    @clk
    if (a == 0) // "continue" loop

```

```
        disable inner_block ;
        ... // statements
        ... // statements
    @clk
    if (a == b) // "break" from loop
        disable outer_block;
        ... // statements
        ... // statements
    end
end
```

NOTE—The C-like **break** and **continue** statements (see [12.8](#)) may be a more intuitive way to code the preceding example.

Example 6—This example shows the **disable** statement being used to disable concurrently a sequence of timing controls and the task named `action` when the `reset` event occurs. The example shows a fork-join block within which are a named sequential block (`event_expr`) and a **disable** statement that waits for occurrence of the event `reset`. The sequential block and the wait for `reset` execute in parallel. The `event_expr` block waits for one occurrence of event `ev1` and three occurrences of event `trig`. When these four events have happened, plus a delay of `d` time units, the task `action` executes. When the event `reset` occurs, regardless of events within the sequential block, the fork-join block terminates—including the task `action`.

```
fork
begin : event_expr
    @ev1;
    repeat (3) @trig;
    #d action (areg, breg);
end
@reset disable event_expr;
join
```

Example 7—The next example is a behavioral description of a retriggerable monostable. The named event `retrig` restarts the monostable time period. If `retrig` continues to occur within 250 time units, then `q` will remain at 1.

```
always begin : monostable
    #250 q = 0;
end

always @retrig begin
    disable monostable;
    q = 1;
end
```

9.6.3 Disable fork statement

The **disable fork** statement terminates all active descendants (subprocesses) of the calling process.

The syntax for **disable fork** is as follows:

```
disable fork ; //from A.6.5
```

The **disable fork** statement terminates all descendants of the calling process as well as the descendants of the process's descendants. In other words, if any of the child processes have descendants of their own, the **disable fork** statement shall terminate them as well.

In the example below, the task `get_first` spawns three versions of a task that wait for a particular device (1, 7, or 13). The task `wait_device` waits for a particular device to become ready and then returns the device's address. When the first device becomes available, the `get_first` task shall resume execution and proceed to kill the outstanding `wait_device` processes.

```

task get_first( output int adr );
  fork
    wait_device( 1, adr );
    wait_device( 7, adr );
    wait_device( 13, adr );
  join_any
  disable fork;
endtask

```

The `disable` construct terminates a process when applied to the named block or statement being executed by the process. The `disable fork` statement differs from `disable` in that `disable fork` considers the dynamic parent-child relationship of the processes, whereas `disable` uses the static, syntactical information of the disabled block. Thus, `disable` shall end all processes executing a particular block, whether the processes were forked by the calling thread or not, while `disable fork` shall end only the processes that were spawned by the calling thread.

9.7 Fine-grain process control

A process is a built-in class that allows one process to access and control another process once it has started. Users can declare variables of type `process` and safely pass them through tasks or incorporate them into other objects. The prototype for the process class is as follows:

```

class process;
  enum state { FINISHED, RUNNING, WAITING, SUSPENDED, KILLED };

  static function process self();
  function state status();
  function void kill();
  task await();
  function void suspend();
  function void resume();
endclass

```

Objects of type `process` are created internally when processes are spawned. Users cannot create objects of type `process`; attempts to call `new` shall not create a new process and shall instead result in an error. The process class cannot be extended. Attempts to extend it shall result in a compilation error. Objects of type `process` are unique; they become available for reuse once the underlying process terminates and all references to the object are discarded.

The `self()` function returns a handle to the current process, that is, a handle to the process making the call.

The `status()` function returns the process status, as defined by the state enumeration:

- **FINISHED** means the process terminated normally.
- **RUNNING** means the process is currently running (not in a blocking statement).
- **WAITING** means the process is waiting in a blocking statement.
- **SUSPENDED** means the process is stopped awaiting a resume.
- **KILLED** means the process was forcibly killed (via `kill` or `disable`).

The `kill()` function terminates the given process and all its subprocesses, that is, processes spawned using `fork` statements by the process being killed. If the process to be terminated is not blocked waiting on some other condition, such as an event, `wait` expression, or a delay, then the process shall be terminated at some unspecified time in the current time step.

The `await()` task allows one process to wait for the completion of another process. It shall be an error to call this task on the current process, i.e., a process cannot wait for its own completion.

The `suspend()` function allows a process to suspend either its own execution or that of another process. If the process to be suspended is not blocked waiting on some other condition, such as an event, `wait` expression, or a delay, then the process shall be suspended at some unspecified time in the current time step. Calling this method more than once, on the same (suspended) process, has no effect.

The `resume()` function restarts a previously suspended process. Calling `resume` on a process that was suspended while blocked on another condition shall resensitize the process to the event expression or to wait for the wait condition to become true or for the delay to expire. If the wait condition is now true or the original delay has transpired, the process is scheduled onto the Active or Reactive region to continue its execution in the current time step. Calling `resume` on a process that suspends itself causes the process to continue to execute at the statement following the call to suspend.

The methods `kill()`, `await()`, `suspend()`, and `resume()` shall be restricted to a process created by an initial procedure, always procedure, or fork block from one of those procedures.

The example below starts an arbitrary number of processes, as specified by the task argument *N*. Next, the task waits for the last process to start executing and then waits for the first process to terminate. At that point, the parent process forcibly terminates all forked processes that have not yet completed.

```
task do_n_way( int N );
  process job[1:N];

  for ( int j = 1; j <= N; j++ )
    fork
      automatic int k = j;
      begin job[k] = process::self(); ... ; end
    join_none

  for( int j = 1; j <= N; j++ )    // wait for all processes to start
    wait( job[j] != null );

  job[1].await();                // wait for first process to finish

  for ( int k = 1; k <= N; k++ ) begin
    if ( job[k].status != process::FINISHED )
      job[k].kill();
  end
endtask
```

10. Assignment statements

10.1 General

This clause describes the following:

- Continuous assignments
- Procedural blocking and nonblocking assignments
- Procedural continuous assignments (assign, deassign, force, release)
- Net aliasing

10.2 Overview

The assignment is the basic mechanism for placing values into nets and variables. There are two basic forms of assignments:

- The *continuous assignment*, which assigns values to nets or variables
- The *procedural assignment*, which assigns values to variables

Continuous assignments drive nets or variables in a manner similar to the way gates drive nets or variables. The expression on the right-hand side can be thought of as a combinational circuit that drives the net or variable continuously. In contrast, procedural assignments put values in variables. The assignment does not have duration; instead, the variable holds the value of the assignment until the next procedural assignment to that variable.

There are two additional forms of assignments, **assign/deassign** and **force/release**, which are called *procedural continuous assignments*, described in [10.6](#).

An assignment consists of two parts, a left-hand side and a right-hand side, separated by the equals (=) character; or, in the case of nonblocking procedural assignment, the less-than-equals (<=) character pair. The right-hand side can be any expression that evaluates to a value. The left-hand side indicates the net or variable to which the right-hand side value is to be assigned. The left-hand side can take one of the forms given in [Table 10-1](#), depending on whether the assignment is a continuous assignment or a procedural assignment.

Table 10-1—Legal left-hand forms in assignment statements

Statement type	Left-hand side
Continuous assignment	Net or variable (vector or scalar) Constant bit-select of a vector net or packed variable Constant part-select of a vector net or packed variable Concatenation or nested concatenation of any of the above left-hand sides
Procedural assignment	Variable (vector or scalar) Bit-select of a packed variable Part-select of a packed variable Memory word Array Array element select Array slice Concatenation or nested concatenation of any of the above left-hand sides

SystemVerilog also allows a time unit to be specified in the assignment statement, as follows:

```
#1ns r = a;
r = #1ns a;
r <= #1ns a;
assign #2.5ns sum = a + b;
```

10.3 Continuous assignments

Continuous assignments shall drive values onto nets or variables, both vector (packed) and scalar. This assignment shall occur whenever the value of the right-hand side changes. Continuous assignments provide a way to model combinational logic without specifying an interconnection of gates. Instead, the model specifies the logical expression that drives the net or variable.

There are two forms of continuous assignments: *net declaration assignments* (see [10.3.1](#)) and *continuous assign statements* (see [10.3.2](#)).

The syntax for continuous assignments is given in [Syntax 10-1](#).

```
net_declaration11 ::= // from A.2.1.3
    net_type [ drive_strength | charge_strength ] [ vectored | scalared ]
    data_type_or_implicit [ delay3 ] list_of_net_decl_assignments ;
list_of_net_decl_assignments ::= net_decl_assignment { , net_decl_assignment } // from A.2.3
net_decl_assignment ::= net_identifier { unpacked_dimension } [ = expression ] // from A.2.4
continuous_assign ::= // from A.6.1
    assign [ drive_strength ] [ delay3 ] list_of_net_assignments ;
    | assign [ delay_control ] list_of_variable_assignments ;
list_of_net_assignments ::= net_assignment { , net_assignment }
list_of_variable_assignments ::= variable_assignment { , variable_assignment }
net_assignment ::= net_lvalue = expression
```

¹¹⁾ A charge strength shall only be used with the **tri**reg keyword. When the **vector**ed or **scal**ared keyword is used, there shall be at least one packed dimension.

Syntax 10-1—Syntax for continuous assignment (excerpt from [Annex A](#))

10.3.1 The net declaration assignment

The *net declaration assignment*, allows a continuous assignment to be placed on a net in the same statement that declares the net.

The following is an example of the net declaration form of a continuous assignment:

```
wire (strong1, pull0) mynet = enable;
```

Because a net can be declared only once, only one net declaration assignment can be made for a particular net. This contrasts with the continuous assignment statement; one net can receive multiple assignments of the continuous assignment form.

10.3.2 The continuous assignment statement

The continuous assignment statement shall place a continuous assignment on a net or variable data type. The net may be explicitly declared or may inherit an implicit declaration in accordance with the implicit declaration rules defined in [6.10](#). Variables shall be explicitly declared prior to the continuous assignment statement.

Assignments on nets or variables shall be continuous and automatic. In other words, whenever an operand in the right-hand expression changes value, the whole right-hand side shall be evaluated. If the new value is different from the previous value, then the new value shall be assigned to the left-hand side.

Nets can be driven by multiple continuous assignments or by a mixture of primitive outputs, module outputs, and continuous assignments. Variables can only be driven by one continuous assignment or by one primitive output or module output. It shall be an error for a variable driven by a continuous assignment or output to have an initializer in the declaration or any procedural assignment. See also [6.5](#).

Example 1—The following is an example of a continuous assignment to a net that has been previously declared:

```
wire mynet ;
assign (strong1, pull0) mynet = enable;
```

Example 2—The following is an example of the use of a continuous assignment to model a 4-bit adder with carry. The assignment could not be specified directly in the declaration of the nets because it requires a concatenation on the left-hand side.

```
module adder (sum_out, carry_out, carry_in, ina, inb);
  output [3:0] sum_out;
  output carry_out;
  input [3:0] ina, inb;
  input carry_in;

  wire carry_out, carry_in;
  wire [3:0] sum_out, ina, inb;

  assign {carry_out, sum_out} = ina + inb + carry_in;
endmodule
```

Example 3—The following example describes a module with one 16-bit output bus. It selects between one of four input busses and connects the selected bus to the output bus.

```
module select_bus(busout, bus0, bus1, bus2, bus3, enable, s);
  parameter n = 16;
  parameter Zee = 16'bz;
  output [1:n] busout;
  input [1:n] bus0, bus1, bus2, bus3;
  input enable;
  input [1:2] s;

  tri [1:n] data;          // net declaration

  // net declaration with continuous assignment
  tri [1:n] busout = enable ? data : Zee;

  // assignment statement with four continuous assignments
  assign
```

```
data = (s == 0) ? bus0 : Zee,  
data = (s == 1) ? bus1 : Zee,  
data = (s == 2) ? bus2 : Zee,  
data = (s == 3) ? bus3 : Zee;  
endmodule
```

The following sequence of events is experienced during simulation of this example:

- a) The value of *s*, a bus selector input variable, is checked in the **assign** statement. Based on the value of *s*, the net *data* receives the data from one of the four input buses.
- b) The setting of net *data* triggers the continuous assignment in the net declaration for *busout*. If *enable* is set, the contents of *data* are assigned to *busout*; if *enable* is 0, the contents of *Zee* are assigned to *busout*.

10.3.3 Continuous assignment delays

A delay given to a continuous assignment shall specify the time duration between a right-hand operand value change and the assignment made to the left-hand side. If the left-hand side references a scalar net, then the delay shall be treated in the same way as for gate delays; that is, different delays can be given for the output rising, falling, and changing to high impedance (see [28.16](#)).

If the left-hand side references a vector net, then up to three delays can be applied. The following rules determine which delay controls the assignment:

- If the right-hand side makes a transition from nonzero to zero, then the falling delay shall be used.
- If the right-hand side makes a transition to *z*, then the turn-off delay shall be used.
- For all other cases, the rising delay shall be used.

Specifying the delay in a continuous assignment that is part of the net declaration shall be treated differently from specifying a net delay and then making a continuous assignment to the net. A delay value can be applied to a net in a net declaration, as in the following example:

```
wire #10 wireA;
```

This syntax, called a *net delay*, means that any value change that is to be applied to *wireA* by some other statement shall be delayed for ten time units before it takes effect. When there is a continuous assignment in a declaration, the delay is part of the continuous assignment and is not a net delay. Thus, it shall not be added to the delay of other drivers on the net. Furthermore, if the assignment is to a vector net, then the rising and falling delays shall not be applied to the individual bits if the assignment is included in the declaration.

In situations where a right-hand operand changes before a previous change has had time to propagate to the left-hand side, then the following steps are taken:

- a) The value of the right-hand expression is evaluated.
- b) If this right-hand side value differs from the value currently scheduled to propagate to the left-hand side, then the currently scheduled propagation event is descheduled.
- c) If the new right-hand side value equals the current left-hand side value, no event is scheduled.
- d) If the new right-hand side value differs from the current left-hand side value, a delay is calculated in the standard way using the current value of the left-hand side, the newly calculated value of the right-hand side, and the delays indicated on the statement; a new propagation event is then scheduled to occur delay time units in the future.

10.3.4 Continuous assignment strengths

The driving strength of a continuous assignment can be specified by the user. This applies only to assignments to scalar nets, except for nets of types **supply0** and **supply1**.

Continuous assignments driving strengths can be specified either in a net declaration or in a stand-alone assignment, using the **assign** keyword. The strength specification, if provided, shall immediately follow the keyword (either the keyword for the net type or **assign**) and precede any delay specified. Whenever the continuous assignment drives the net, the strength of the value shall be simulated as specified.

A drive strength specification shall contain one strength value that applies when the value being assigned to the net is 1 and a second strength value that applies when the assigned value is 0. The following keywords shall specify the strength value for an assignment of 1:

supply1 **strong1** **pull1** **weak1** **highz1**

The following keywords shall specify the strength value for an assignment of 0:

supply0 **strong0** **pull0** **weak0** **highz0**

The order of the two strength specifications shall be arbitrary. The following two rules shall constrain the use of drive strength specifications:

- The strength specifications (**highz1**, **highz0**) and (**highz0**, **highz1**) shall be treated as illegal constructs.
- If drive strength is not specified, it shall default to (**strong1**, **strong0**).

10.4 Procedural assignments

Procedural assignments occur within procedures such as **always**, **initial** (see 9.2), **task**, and **function** (see Clause 13) and can be thought of as “triggered” assignments. The trigger occurs when the flow of execution in the simulation reaches an assignment within a procedure. Reaching the assignment can be controlled by conditional statements. Event controls, delay controls, **if** statements, **case** statements, and looping statements can all be used to control whether assignments are evaluated. Clause 12 gives details and examples.

The right-hand side of a procedural assignment can be any expression that evaluates to a value, however the variable type on the left-hand side may restrict what is a legal expression on the right-hand side. The left-hand side shall be a variable that receives the assignment from the right-hand side. The left-hand side of a procedural assignment can take one of the following forms:

- Singular variables, as described in 6.4
- Aggregate variables, as described in Clause 7
- Bit-selects, part-selects and slices of packed arrays
- Slices of unpacked arrays

SystemVerilog contains three types of procedural assignment statements:

- Blocking procedural assignment statements (see 10.4.1)
- Nonblocking procedural assignment statements (see 10.4.2)
- Assignment operators (see 11.4.1)

Blocking and nonblocking procedural assignment statements specify different procedural flows in sequential blocks.

10.4.1 Blocking procedural assignments

A *blocking procedural assignment* statement shall be executed before the execution of the statements that follow it in a sequential block (see [9.3.1](#)). A blocking procedural assignment statement shall not prevent the execution of statements that follow it in a parallel block (see [9.3.2](#)).

The syntax for a blocking procedural assignment is given in [Syntax 10-2](#).

```
blocking_assignment ::= //from A.6.3
    variable_lvalue = delay_or_event_control expression
  | nonrange_variable_lvalue = dynamic_array_new
  | [ implicit_class_handle . | class_scope | package_scope ] hierarchical_variable_identifier
    select = class_new
  | operator_assignment
operator_assignment ::= variable_lvalue assignment_operator expression
assignment_operator ::=
    = | += | -= | *= | /= | %= | &= | |= | ^= | <<= | >>= | <<<= | >>>=
```

Syntax 10-2—Blocking assignment syntax (excerpt from [Annex A](#))

In this syntax, *variable_lvalue* is a data type that is valid for a procedural assignment statement, = is the assignment operator, and *delay_or_event_control* is the optional intra-assignment timing control (see [9.4.5](#)). The expression is the right-hand side value that shall be assigned to the left-hand side. If *variable_lvalue* requires an evaluation, it shall be evaluated at the time specified by the intra-assignment timing control. The order of evaluation of the *variable_lvalue* and the expression on the right-hand side is undefined if a timing control is not specified. See [4.9.3](#).

The = assignment operator used by blocking procedural assignments is also used by procedural continuous assignments and continuous assignments.

The following examples show blocking procedural assignments:

```
rega = 0;
rega[3] = 1;           // a bit-select
rega[3:5] = 7;        // a part-select
mema[address] = 8'hff; // assignment to a mem element
{carry, acc} = rega + regb; // a concatenation
```

Additional assignment operators, such as +=, are described in [11.4.1](#).

10.4.2 Nonblocking procedural assignments

The *nonblocking procedural assignment* allows assignment scheduling without blocking the procedural flow. The nonblocking procedural assignment statement can be used whenever several variable assignments within the same time step can be made without regard to order or dependence upon each other.

It shall be illegal to make nonblocking assignments to automatic variables.

The syntax for a nonblocking procedural assignment is given in [Syntax 10-3](#).

nonblocking_assignment ::= variable_lvalue <= [delay_or_event_control] expression // from [A.6.3](#)

Syntax 10-3—Nonblocking assignment syntax (excerpt from [Annex A](#))

In this syntax, *variable_lvalue* is a data type that is valid for a procedural assignment statement, <= is the nonblocking assignment operator, and *delay_or_event_control* is the optional intra-assignment timing control (see [9.4.5](#)). If *variable_lvalue* requires an evaluation, it shall be evaluated at the same time as the expression on the right-hand side. The order of evaluation of the *variable_lvalue* and the expression on the right-hand side is undefined (see [4.9.4](#)).

The nonblocking assignment operator is the same operator as the less-than-or-equal-to relational operator. The interpretation shall be decided from the context in which <= appears. When <= is used in an expression, it shall be interpreted as a relational operator; and when it is used in a nonblocking procedural assignment, it shall be interpreted as an assignment operator.

The nonblocking procedural assignments shall be evaluated in two steps as discussed in [Clause 4](#). These two steps are shown in the following example:

Example 1

```
module evaluates (out);
  output out;
  logic a, b, c;

  initial begin
    a = 0;
    b = 1;
    c = 0;
  end

  always c = #5 ~c;

  always @(posedge c) begin
    a <= b; // evaluates, schedules,
    b <= a; // and executes in two steps
  end
endmodule
```

Step 1: At posedge c, the simulator evaluates the right-hand sides of the nonblocking assignments and schedules the assignments of the new values at the end of the *nonblocking assign update* events NBA region (see [4.5](#)).

Step 2: When the simulator activates the *nonblocking assign update* events, the simulator updates the left-hand side of each nonblocking assignment statement.

Nonblocking assignment schedules change at time 5

a = 0
b = 1

assignment values

a = 1
b = 0

At the end of the time step means that the nonblocking assignments are the last assignments executed in a time step—with one exception. Nonblocking assignment events can create blocking assignment events. These blocking assignment events shall be processed after the scheduled nonblocking events.

Unlike an event or delay control for blocking assignments, the nonblocking assignment does not block the procedural flow. The nonblocking assignment evaluates and schedules the assignment, but it does not block the execution of subsequent statements in a begin-end block.

Example 2

```

module nonblock1;
  logic a, b, c, d, e, f;

  // blocking assignments
  initial begin
    a = #10 1; // a will be assigned 1 at time 10
    b = #2 0; // b will be assigned 0 at time 12
    c = #4 1; // c will be assigned 1 at time 16
  end

  // nonblocking assignments
  initial begin
    d <= #10 1; // d will be assigned 1 at time 10
    e <= #2 0; // e will be assigned 0 at time 2
    f <= #4 1; // f will be assigned 1 at time 4
  end
endmodule

```

*scheduled
changes at
time 2*

e = 0

*scheduled
changes at
time 4*

f = 1

*scheduled
changes at
time 10*

d = 1

As shown in the previous example, the simulator evaluates and schedules assignments for the end of the current time step and can perform swapping operations with the nonblocking procedural assignments.

Example 3

```

module nonblock2;
  logic a, b;
  initial begin
    a = 0;
    b = 1;
    a <= b; // evaluates, schedules,
    b <= a; // and executes in two steps
  end

  initial begin
    $monitor ($time, , "a = %b b = %b", a, b);
    #100 $finish;
  end
endmodule

```

Step 1: The simulator evaluates the right-hand side of the nonblocking assignments and schedules the assignments for the end of the current time step.

Step 2: At the end of the current time step, the simulator updates the left-hand side of each nonblocking assignment statement.

*assignment
values*

a = 1

b = 0

The order of the execution of distinct nonblocking assignments to a given variable shall be preserved. In other words, if there is clear ordering of the execution of a set of nonblocking assignments, then the order of the resulting updates of the destination of the nonblocking assignments shall be the same as the ordering of the execution (see [4.6](#)).

Example 4

```

module multiple;
  logic a;

  initial a = 1;
  // The assigned value of the variable is determinate

  initial begin
    a <= #4 0; // schedules a = 0 at time 4
    a <= #4 1; // schedules a = 1 at time 4
  end

```

```

    end                // At time 4, a = 1
endmodule

```

If the simulator executes two procedural blocks concurrently and if these procedural blocks contain non-blocking assignment operators to the same variable, the final value of that variable is indeterminate. For example, the value of variable *a* is indeterminate in the following example:

Example 5

```

module multiple2;
    logic a;

    initial a = 1;
    initial a <= #4 0; // schedules 0 at time 4
    initial a <= #4 1; // schedules 1 at time 4

    // At time 4, a = ??
    // The assigned value of the variable is indeterminate
endmodule

```

The fact that two nonblocking assignments targeting the same variable are in different blocks is not by itself sufficient to make the order of assignments to a variable indeterminate. For example, the value of variable *a* at the end of time cycle 16 is determinate in the following example:

Example 6

```

module multiple3;
    logic a;

    initial #8 a <= #8 1; // executed at time 8;
                        // schedules an update of 1 at time 16
    initial #12 a <= #4 0; // executed at time 12;
                        // schedules an update of 0 at time 16

    // Because it is determinate that the update of a to the value 1
    // is scheduled before the update of a to the value 0,
    // then it is determinate that a will have the value 0
    // at the end of time slot 16.
endmodule

```

The following example shows how the value of *i*[0] is assigned to *r1* and how the assignments are scheduled to occur after each time delay:

Example 7

```

module multiple4;
    logic r1;
    logic [2:0] i;

    initial begin
        // makes assignments to r1 without cancelling previous assignments
        for (i = 0; i <= 5; i++)
            r1 <= # (i*10) i[0];
    end
endmodule

```

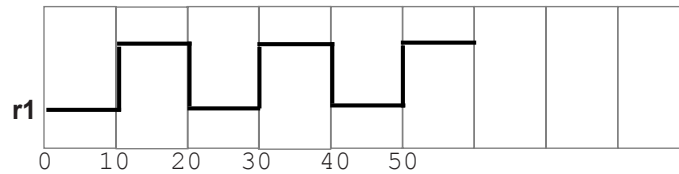
10.5 Variable declaration assignment (variable initialization)

Unlike nets, a variable cannot have an implicit continuous assignment as part of its declaration. An assignment as part of the declaration of a variable is a variable initialization, not a continuous assignment.

The variable declaration assignment is a special case of procedural assignment as it assigns a value to a variable. It allows an initial value to be placed in a variable in the same statement that declares the variable (see 6.8). The assignment does not have duration; instead, the variable holds the value until the next assignment to that variable.

For example:

```

wire w = vara & varb;           // net with a continuous assignment
logic v = consta & constb;     // variable with initialization

```

Setting the initial value of a static variable as part of the variable declaration (including static class members) shall occur before any initial or always procedures are started. See also 6.21.

10.6 Procedural continuous assignments

The *procedural continuous assignments* (using keywords **assign** and **force**) are procedural statements that allow expressions to be driven continuously onto variables or nets. The syntax for these statements is given in [Syntax 10-4](#).

```

procedural_continuous_assignment ::=                                     // from 4.6.2
    assign variable_assignment
  | deassign variable_lvalue
  | force variable_assignment
  | force net_assignment
  | release variable_lvalue
  | release net_lvalue
variable_assignment ::= variable_lvalue = expression
net_assignment ::= net_lvalue = expression                             // from 4.6.1

```

Syntax 10-4—Syntax for procedural continuous assignments (excerpt from [Annex A](#))

The right-hand side of an **assign** procedural continuous assignment or a **force** statement can be an expression. This shall be treated just as a continuous assignment; that is, if any variable on the right-hand side of the assignment changes, the assignment shall be reevaluated while the assign or force is in effect. For example:

```
force a = b + f(c) ;
```

Here, if `b` changes or `c` changes, `a` will be forced to the new value of the expression `b+f(c)`.

10.6.1 The assign and deassign procedural statements

The **assign** procedural continuous assignment statement shall override all procedural assignments to a variable. The **deassign** procedural statement shall end a procedural continuous assignment to a variable. The value of the variable shall remain the same until the variable is assigned a new value through a procedural assignment or a procedural continuous assignment. The assign and deassign procedural statements allow, for example, modeling of asynchronous clear/preset on a D-type edge-triggered flip-flop, where the clock is inhibited when the clear or preset is active.

The left-hand side of the assignment in the *assign statement* shall be a singular variable reference or a concatenation of variables. It shall not be a bit-select or a part-select of a variable.

If the keyword **assign** is applied to a variable for which there is already a procedural continuous assignment, then this new procedural continuous assignment shall deassign the variable before making the new procedural continuous assignment.

The following example shows a use of the assign and deassign procedural statements in a behavioral description of a D-type flip-flop with preset and clear inputs:

```
module dff (q, d, clear, preset, clock);
  output q;
  input d, clear, preset, clock;
  logic q;

  always @(clear or preset)
    if (!clear)
      assign q = 0;
    else if (!preset)
      assign q = 1;
    else
      deassign q;

  always @(posedge clock)
    q = d;
endmodule
```

If either `clear` or `preset` is low, then the output `q` will be held continuously to the appropriate constant value, and a positive edge on the `clock` will not affect `q`. When both the `clear` and `preset` are high, then `q` is deassigned.

NOTE—The procedural assign and deassign constructs are under consideration for deprecation. See [Annex C](#).

10.6.2 The force and release procedural statements

Another form of procedural continuous assignment is provided by the **force** and **release** procedural statements. These statements have a similar effect to the **assign-deassign** pair, but a force can be applied to nets as well as to variables. The left-hand side of the assignment can be a reference to a singular variable, a net, a constant bit-select of a vector net, a constant part-select of a vector net, or a concatenation of these. It shall not be a bit-select or a part-select of a variable. A **force** or **release** statement shall not be applied to a variable that is being assigned by a mixture of continuous and procedural assignments.

A **force** statement to a variable shall override a procedural assignment, continuous assignment or an **assign** procedural continuous assignment to the variable until a **release** procedural statement is executed on the variable. When released, then if the variable is not driven by a continuous assignment and does not currently have an active **assign** procedural continuous assignment, the variable shall not immediately change value and shall maintain its current value until the next procedural assignment to the variable is executed. Releasing a variable that is driven by a continuous assignment or currently has an active **assign** procedural continuous assignment shall reestablish that assignment and schedule a reevaluation in the continuous assignment's scheduling region.

A **force** procedural statement on a net shall override all drivers of the net—gate outputs, module outputs, and continuous assignments—until a **release** procedural statement is executed on the net. When released, the net shall immediately be assigned the value determined by the drivers of the net.

For example:

```
module test;
  logic a, b, c, d;
  wire e;

  and and1 (e, a, b, c);

  initial begin
    $monitor("%d d=%b,e=%b", $stime, d, e);
    assign d = a & b & c;
    a = 1;
    b = 0;
    c = 1;
    #10;
    force d = (a | b | c);
    force e = (a | b | c);
    #10;
    release d;
    release e;
    #10 $finish;
  end
endmodule
```

```
Results:
  0 d=0,e=0
 10 d=1,e=1
 20 d=0,e=0
```

In this example, an **and** gate instance, `and1`, is “patched” to act like an **or** gate by a **force** procedural statement that forces its output to the value of its ORed inputs, and an **assign** procedural statement of ANDed values is “patched” to act like an assign statement of ORed values.

10.7 Assignment extension and truncation

The size of the left-hand side of an assignment forms the context for the right-hand expression.

The following are the steps for evaluating an assignment:

- Determine the size of the left-hand side and right-hand side by the standard expression size determination rules (see [11.8.1](#)).

- When the right-hand side evaluates to fewer bits than the left-hand side, the right-hand side value is padded to the size of the left-hand side. If the right-hand side is unsigned, it is padded according to the rules specified in [11.6.1](#). If the right-hand side is signed, it is sign-extended.
- If the left-hand side is smaller than the right-hand side, truncation shall occur, as described in the following paragraphs.

If the width of the right-hand expression is larger than the width of the left-hand side in an assignment, the MSBs of the right-hand expression shall be discarded to match the size of the left-hand side. Implementations can, but are not required to, warn or report any errors related to assignment size mismatch or truncation. Size casting can be used to indicate explicit intent to change the size (see [6.24.1](#)). Truncating the sign bit of a signed expression may change the sign of the result.

Some examples of assignment truncation follow.

Example 1:

```
logic [5:0] a;
logic signed [4:0] b;

initial begin
    a = 8'hff;      // After the assignment, a = 6'h3f
    b = 8'hff;      // After the assignment, b = 5'h1f
end
```

Example 2:

```
logic [0:5] a;
logic signed [0:4] b, c;

initial begin
    a = 8'sh8f;     // After the assignment, a = 6'h0f
    b = 8'sh8f;     // After the assignment, b = 5'h0f
    c = -113;       // After the assignment, c = 15
                    // 1000_1111 = (-'h71 = -113) truncates to ('h0F = 15)
end
```

Example 3:

```
logic [7:0] a;
logic signed [7:0] b;
logic signed [5:0] c, d;

initial begin
    a = 8'hff;
    c = a;          // After the assignment, c = 6'h3f
    b = -113;
    d = b;          // After the assignment, d = 6'h0f
end
```

10.8 Assignment-like contexts

An assignment-like context is as follows:

- A continuous or procedural assignment
- For a parameter with an explicit type declaration:
 - A parameter value assignment in a module, interface, program, or class

- A parameter value override in the instantiation of a module, interface, or program
- A parameter value override in the instantiation of a class or in the left-hand side of a class scope operator
- A port connection to an input or output port of a module, interface, or program
- The passing of a value to a subroutine input, output, or inout port
- A return statement in a function
- A tagged union expression
- For an expression that is used as the right-hand value in an assignment-like context:
 - If a parenthesized expression, then the expression within the parentheses
 - If a mintypmax expression, then the colon-separated expressions
 - If a conditional operator expression, then the second and third operand
- A nondefault correspondence between an expression in an assignment pattern and a field or element in a data object or data value

No other contexts shall be considered assignment-like contexts. In particular, none of the following shall be considered assignment-like contexts:

- A static cast
- A default correspondence between an expression in an assignment pattern and a field or element in a data object or data value
- A port expression in a module, interface, or program declaration
- The passing of a value to a subroutine **ref** port
- A port connection to an **inout** or **ref** port of a module, interface, or program

10.9 Assignment patterns

Assignment patterns are used for assignments to describe patterns of assignments to structure fields and array elements.

An assignment pattern specifies a correspondence between a collection of expressions and the fields and elements in a data object or data value. An assignment pattern has no self-determined data type, but can be used as one of the sides in an assignment-like context (see [10.8](#)) when the other side has a self-determined data type. An assignment pattern is built from braces, keys, and expressions and is prefixed with an apostrophe. For example:

```
var int A[N] = '{default:1};  
var integer i = '{31:1, 23:1, 15:1, 8:1, default:0};  
  
typedef struct {real r, th;} C;  
var C x = '{th:PI/2.0, r:1.0};  
var real y [0:1] = '{0.0, 1.1}, z [0:9] = '{default: 3.1416};
```

A positional notation without keys can also be used. For example:

```
var int B[4] = '{a, b, c, d};  
var C y = '{1.0, PI/2.0};  
'{a, b, c, d} = B;
```

When an assignment pattern is used as the left-hand side of an assignment-like context, the positional notation shall be required; and each member expression shall have a bit-stream data type that is assignment

compatible with and has the same number of bits as the data type of the corresponding element on the right-hand side.

The assignment pattern syntax is listed in [Syntax 10-5](#).

```

assignment_pattern ::= // from A.6.7.1
  '{ expression { , expression } }'
  | '{ structure_pattern_key : expression { , structure_pattern_key : expression } }'
  | '{ array_pattern_key : expression { , array_pattern_key : expression } }'
  | '{ constant_expression { expression { , expression } } }'
structure_pattern_key ::= member_identifier | assignment_pattern_key
array_pattern_key ::= constant_expression | assignment_pattern_key
assignment_pattern_key ::= simple_type | default
assignment_pattern_expression ::=
  [ assignment_pattern_expression_type ] assignment_pattern
assignment_pattern_expression_type ::=
  ps_type_identifier
  | ps_parameter_identifier
  | integer_atom_type
  | type_reference
constant_assignment_pattern_expression28 ::= assignment_pattern_expression

```

²⁸⁾ In a constant_assignment_pattern_expression, all member expressions shall be constant expressions.

Syntax 10-5—Assignment patterns syntax (excerpt from [Annex A](#))

An assignment pattern can be used to construct or deconstruct a structure or array by prefixing the pattern with the name of a data type to form an assignment pattern expression. Unlike an assignment pattern, an assignment pattern expression has a self-determined data type and is not restricted to being one of the sides in an assignment-like context. When an assignment pattern expression is used in a right-hand expression, it shall yield the value that a variable of the data type would hold if it were initialized using the assignment pattern.

```

typedef logic [1:0] [3:0] T;
shortint'({T'{1,2}, T'{3,4}}) // yields 16'sh1234

```

When an assignment pattern expression is used in a left-hand expression, the positional notation shall be required; and each member expression shall have a bit-stream data type that is assignment compatible with and has the same number of bits as the corresponding element in the data type of the assignment pattern expression. If the right-hand expression has a self-determined data type, then it shall be assignment compatible with and have the same number of bits as the data type of the assignment pattern expression.

```

typedef byte U[3];
var U A = '{1, 2, 3};
var byte a, b, c;
U'{a, b, c} = A;
U'{c, a, b} = '{a+1, b+1, c+1};

```

An assignment pattern expression shall not be used in a port expression in a module, interface, or program declaration.

10.9.1 Array assignment patterns

Concatenation braces are used to construct and deconstruct simple bit vectors. A similar syntax is used to support the construction and deconstruction of arrays. The expressions shall match element for element, and the braces shall match the array dimensions. Each expression item shall be evaluated in the context of an assignment to the type of the corresponding element in the array. In other words, the following examples are not required to cause size warnings:

```
bit  unpackedbits [1:0] = '{1,1};           // no size warning required as
                                           // bit can be set to 1
int  unpackedints [1:0] = '{1'b1, 1'b1};    // no size warning required as
                                           // int can be set to 1'b1
```

A syntax resembling replications (see [11.4.12.1](#)) can be used in array assignment patterns as well. Each replication shall represent an entire single dimension.

```
unpackedbits = '{2 {y}} ;                 // same as '{y, y}
int  n[1:2][1:3] = '{2{'{3{y}}}};         // same as '{'{y,y,y}','{y,y,y}}
```

SystemVerilog determines the context of the braces when used in the context of an assignment.

It can sometimes be useful to set array elements to a value without having to keep track of how many members there are. This can be done with the **default** keyword:

```
initial unpackedints = '{default:2};      // sets elements to 2
```

For arrays of structures, it is useful to specify one or more matching type keys, as described under structure assignment patterns below in [10.9.2](#).

```
struct {int a; time b;} abkey[1:0];
abkey = '{a:1, b:2ns}, '{int:5, time:$time};
```

The matching rules are as follows:

- An **index:value** specifies an explicit value for a keyed element index. The value is evaluated in the context of an assignment to the indexed element and shall be castable to its type. It shall be an error to specify the same index more than once in a single array pattern expression.
- For **type:value**, if the element or subarray type of the array matches this type, then each element or subarray that has not already been set by an index key above shall be set to the value. The value shall be castable to the array element or subarray type. Otherwise, if the array is multidimensional, then there is a recursive descent into each subarray of the array using the rules in this clause and the type and default keys. Otherwise, if the array is an array of structures, there is a recursive descent into each element of the array using the rules for structure assignment patterns and the type and default keys. If more than one type matches the same element, the last value shall be used.
- The **default:value** applies to elements or subarrays that are not matched by either index or type key. If the type of the element or subarray is a simple bit vector type, matches the self-determined type of the value, or is not an array or structure type, then the value is evaluated in the context of each assignment to an element or subarray by the default and shall be castable to the type of the element or subarray; otherwise, an error is generated. For unmatched subarrays, the type and default specifiers are applied recursively according to the rules in this clause to each of its elements or subarrays. For unmatched structure elements, the type and default keys are applied to the element according to the rules for structures.

Every element shall be covered by one of these rules.

If the type key, default key, or replication operator is used on an expression with side effects, the number of times that expression evaluates is undefined.

10.9.2 Structure assignment patterns

A structure can be constructed and deconstructed with a structure assignment pattern built from member expressions using braces and commas, with the members in declaration order. Replication operators can be used to set the values for the exact number of members. Each member expression shall be evaluated in the context of an assignment to the type of the corresponding member in the structure. It can also be built with the names of the members.

```

module mod1;

    typedef struct {
        int x;
        int y;
    } st;

    st s1;
    int k = 1;

    initial begin
        #1 s1 = '{1, 2+k};           // by position
        #1 $display( s1.x, s1.y);
        #1 s1 = '{x:2, y:3+k};      // by name
        #1 $display( s1.x, s1.y);
        #1 $finish;
    end
endmodule

```

It can sometimes be useful to set structure members to a value without having to keep track of how many members there are or what the names are. This can be done with the **default** keyword:

```

initial s1 = '{default:2}; // sets x and y to 2

```

The '{member:value} or '{data_type: default_value} syntax can also be used:

```

ab abkey[1:0] = '{a:1, b:1.0}, '{int:2, shortreal:2.0}};

```

Use of the **default** keyword applies to members in nested structures or elements in unpacked arrays in structures.

```

struct {
    int A;
    struct {
        int B, C;
    } BC1, BC2;
} ABC, DEF;

ABC = '{A:1, BC1:'{B:2, C:3}, BC2:'{B:4,C:5}};
DEF = '{default:10};

```

To deal with the problem of members of different types, a type can be used as the key. This overrides the default for members of that type:

```

typedef struct {
    logic [7:0] a;

```



```
    bit b;  
    bit signed [31:0] c;  
    string s;  
} sa;  
  
sa s2;  
initial s2 = '{int:1, default:0, string:""}; // set all to 0 except the  
// array of bits to 1 and  
// string to ""
```

Similarly, an individual member can be set to override the general default and the type default:

```
initial #10 s2 = '{default:'1, s : ""}; // set all to 1 except s to ""
```

SystemVerilog determines the context of the braces when used in the context of an assignment.

The matching rules are as follows:

- A `member:value` specifies an explicit value for a named member of the structure. The named member shall be at the top level of the structure; a member with the same name in some level of substructure shall not be set. The value shall be castable to the member type and is evaluated in the context of an assignment to the named member; otherwise, an error is generated.
- The `type:value` specifies an explicit value for each field in the structure whose type matches the type (see [6.22.1](#)) and has not been set by a field name key above. If the same type key is mentioned more than once, the last value is used. The value is evaluated in the context of an assignment to the matching type.
- The `default:value` applies to members that are not matched by either member name or type key. If the member type is a simple bit vector type, matches the self-determined type of the value, or is not an array or structure type, then the value is evaluated in the context of each assignment to a member by the default and shall be castable to the member type; otherwise, an error is generated. For unmatched structure members, the type and default specifiers are applied recursively according to the rules in this clause to each member of the substructure. For unmatched array members, the type and default keys are applied to the array according to the rules for arrays.

Every member shall be covered by one of these rules.

If the type key, default key, or replication operator is used on an expression with side effects, the number of times that expression evaluates is undefined.

10.10 Unpacked array concatenation

Unpacked array concatenation provides a flexible way to compose an unpacked array value from a collection of elements and arrays. An unpacked array concatenation may appear as the source expression in an assignment-like context, and shall not appear in any other context. The target of such assignment-like context shall be an array whose slowest-varying dimension is an unpacked fixed-size, queue or dynamic dimension. A target of any other type (including associative array) shall be illegal.

An unpacked array concatenation shall be written as a comma-separated list, enclosed in braces, of zero or more items. If the list has zero items, then the concatenation shall denote an array value with no elements. Otherwise, each item shall represent one or more elements of the resulting array value, interpreted as follows:

- An item whose self-determined type is assignment-compatible with the element type of the target array shall represent a single element

- An item whose self-determined type is an unpacked array whose slowest-varying dimension's element type is assignment compatible with the element type of the target array shall represent as many elements as exist in that item, arranged in the same left-to-right order as they would appear in the array item itself
- An item of any other type, or an item that has no self-determined type, shall be illegal except that the literal value `null` shall be legal if the target array's elements are of class type

The elements thus represented shall be arranged in left-to-right order to form the resulting array. It shall be an error if the size of the resulting array differs from the number of elements in a fixed-size target. If the size exceeds the maximum number of elements of a bounded queue, then elements beyond the upper bound of the target shall be ignored and a warning shall be issued.

10.10.1 Unpacked array concatenations compared with array assignment patterns

Array assignment patterns have the advantage that they can be used to create assignment pattern expressions of self-determined type by prefixing the pattern with a type name. Furthermore, items in an assignment pattern can be replicated using syntax such as `{ n{element} }`, and can be defaulted using the `default:` syntax. However, every element item in an array assignment pattern must be of the same type as the element type of the target array. By contrast, unpacked array concatenations forbid replication, defaulting and explicit typing, but they offer the additional flexibility of composing an array value from an arbitrary mix of elements and arrays. In some simple cases both forms can have the same effect, as in the following example:

```
int A3[1:3];
A3 = {1, 2, 3}; // unpacked array concatenation: A3[1]=1, A3[2]=2, A3[3]=3
A3 = '{1, 2, 3}; // array assignment pattern: A3[1]=1, A3[2]=2, A3[3]=3
```

The next examples illustrate some differences between the two forms:

```
typedef int AI3[1:3];
AI3 A3;
int A9[1:9];

A3 = '{1, 2, 3};
A9 = '{3{A3}}; // illegal, A3 is wrong element type
A9 = '{A3, 4, 5, 6, 7, 8, 9}; // illegal, A3 is wrong element type
A9 = {A3, 4, 5, A3, 6}; // legal, gives A9='{1,2,3,4,5,1,2,3,6}
A9 = '{9{1}}; // legal, gives A9='{1,1,1,1,1,1,1,1,1}
A9 = {9{1}}; // illegal, no replication in unpacked
// array concatenation
A9 = {A3, {4,5,6,7,8,9}}; // illegal, {...} is not self-determined here
A9 = {A3, '{4,5,6,7,8,9}}; // illegal, '{...' is not self-determined
A9 = {A3, 4, AI3'{5, 6, 7}, 8, 9}; // legal, A9='{1,2,3,4,5,6,7,8,9}
```

Unpacked array concatenation is especially useful for writing values of queue type, as shown in the examples in [7.10.4](#).

10.10.2 Relationship with other constructs that use concatenation syntax

Concatenation syntax with braces can be used in other SystemVerilog constructs, including vector concatenation and string concatenation. These forms of concatenation are expressions of self-determined type, unlike unpacked array concatenation which does not have a self-determined type and which must appear as the source expression in an assignment-like context. If concatenation braces appear in an assignment-like context with an unpacked array target, they unambiguously act as unpacked array concatenation and must conform to the rules given in [10.10](#), above. Otherwise, they form a vector or string concatenation according

to the rules given in [11.4.12](#). The following examples illustrate how the same expression can have different meanings in different contexts without ambiguity.

```
string S, hello;
string SA[2];
byte B;
byte BA[2];

hello = "hello";

S = {hello, " world"}; // string concatenation: "hello world"
SA = {hello, " world"}; // array concatenation:
                        // SA[0]="hello", SA[1]=" world"

B = {4'h6, 4'hf};      // vector concatenation: B=8'h6f
BA = {4'h6, 4'hf};    // array concatenation: BA[0]=8'h06, BA[1]=8'h0f
```

10.10.3 Nesting of unpacked array concatenations

Each item of an unpacked array concatenation shall have a self-determined type (see [10.10](#)), but a complete unpacked array concatenation has no self-determined type. Consequently it shall be illegal for an unpacked array concatenation to appear as an item in another unpacked array concatenation. This rule makes it possible for a vector or string concatenation to appear as an item in an unpacked array concatenation without ambiguity, as illustrated in the following example.

```
string S1, S2;
typedef string T_SQ[$];
T_SQ SQ;

S1 = "S1";
S2 = "S2";
SQ = {"element 0", "element 1"}; // assignment pattern, two strings
SQ = {S1, SQ, {"element 3 is ", S2} };
```

In the last line of the example above, the outer pair of braces encloses an unpacked array concatenation whereas the inner pair of braces encloses a string concatenation, so that the resulting queue of strings is

```
'{"S1", "element 0", "element 1", "element 3 is S2"}
```

Alternatively the third item in the unpacked array concatenation could instead represent an array of strings, if it were written as an assignment pattern expression. The unpacked array concatenation would still be valid in this case, but now it would treat its third item as an array of two strings, each forming one element of the resulting array:

```
SQ = {S1, SQ, T_SQ{"element 3 is ", S2} };
// result: {"S1", "element 0", "element 1", "element 3 is ", "S2"}
```

With the exception of **default**: items, each item of an assignment pattern or an assignment pattern expression is in an assignment-like context (see [10.9](#)). Consequently an unpacked array concatenation may appear as a non-default item in an assignment pattern. The following example uses a two-dimensional queue to build a jagged array of arrays of int, using both an assignment pattern expression and unpacked array concatenations to represent the subarrays:

```
typedef int T_QI[$];
T_QI jagged_array[$] = '{ {1}, T_QI{2,3,4}, {5,6} }';
```

```
// jagged_array[0][0] = 1 -- jagged_array[0] is a queue of 1 int

// jagged_array[1][0] = 2 -- jagged_array[1] is a queue of 3 ints
// jagged_array[1][1] = 3
// jagged_array[1][2] = 4

// jagged_array[2][0] = 5 -- jagged_array[2] is a queue of 2 ints
// jagged_array[2][1] = 6
```

10.11 Net aliasing

An alias statement declares multiple names for the same physical net, or bits within a net. The syntax for an alias statement is as follows:

```
net_alias ::= alias net_lvalue = net_lvalue { = net_lvalue } ; //from A.6.1
net_lvalue ::= //from A.8.5
  ps_or_hierarchical_net_identifier constant_select
  | { net_lvalue { , net_lvalue } }
  | [ assignment_pattern_expression_type ] assignment_pattern_net_lvalue
```

Syntax 10-6—Syntax for net aliasing (excerpt from [Annex A](#))

The continuous **assign** statement is a unidirectional assignment and can incorporate a delay and strength change. To model a bidirectional short circuit connection, it is necessary to use the **alias** statement. The members of an alias list are signals whose bits share the same physical nets. The following example implements a byte order swapping between bus A and bus B:

```
module byte_swap (inout wire [31:0] A, inout wire [31:0] B);
  alias {A[7:0],A[15:8],A[23:16],A[31:24]} = B;
endmodule
```

This example strips out the LSB and MSB from a 4-byte bus:

```
module byte_rip (inout wire [31:0] W, inout wire [7:0] LSB, MSB);
  alias W[7:0] = LSB;
  alias W[31:24] = MSB;
endmodule
```

The bit overlay rules are the same as for a packed union with the same member types: each member shall be the same size, and connectivity is independent of the simulation host. The nets connected with an **alias** statement shall be type compatible, that is, they have to be of the same net type. For example, it is illegal to connect a **wand** net to a **wor** net with an **alias** statement. This rule is stricter than the rule applied to nets joining at ports because the scope of an alias is limited and such connections are more likely to be a design error. Variables and hierarchical references cannot be used in **alias** statements. Any violation of these rules shall be considered a fatal error.

The same nets can appear in multiple **alias** statements. The effects are cumulative. The following two examples are equivalent. In either case, `low12[11:4]` and `high12[7:0]` share the same wires.

```
module overlap(inout wire [15:0] bus16, inout wire [11:0] low12, high12);
  alias bus16[11:0] = low12;
  alias bus16[15:4] = high12;
endmodule
```

```

module overlap(inout wire [15:0] bus16, inout wire [11:0] low12, high12);
  alias bus16 = {high12, low12[3:0]};
  alias high12[7:0] = low12[11:4];
endmodule

```

To avoid errors in specification, it is not allowed to specify an alias from an individual signal to itself or to specify a given alias more than once. The following version of the code above would be illegal because the top 4 bits and bottom 4 bits are the same in both statements:

```

alias bus16 = {high12[11:8], low12};
alias bus16 = {high12, low12[3:0]};

```

This alternative is also illegal because the bits of `bus16` are being aliased to itself:

```

alias bus16 = {high12, bus16[3:0]} = {bus16[15:12], low12};

```

alias statements can appear anywhere module instance statements can appear. If an identifier that has not been declared as a data type appears in an **alias** statement, then an implicit net is assumed, following the same rules as implicit nets for a module instance. The following example uses **alias** along with the automatic name binding to connect pins on cells from different libraries to create a standard macro:

```

module lib1_dff(Reset, Clk, Data, Q, Q_Bar);
  ...
endmodule

module lib2_dff(reset, clock, data, q, qbar);
  ...
endmodule

module lib3_dff(RST, CLK, D, Q, Q_);
  ...
endmodule

module my_dff(rst, clk, d, q, q_bar); // wrapper cell
  input rst, clk, d;
  output q, q_bar;
  alias rst = Reset = reset = RST;
  alias clk = Clk = clock = CLK;
  alias d = Data = data = D;
  alias q = Q;
  alias Q_ = q_bar = Q_Bar = qbar;
  `LIB_DFF my_dff (.*) ; // LIB_DFF is any of lib1_dff, lib2_dff or lib3_dff
endmodule

```

Using a net in an **alias** statement does not modify its syntactic behavior in other statements. Aliasing is performed at elaboration time and cannot be undone.

11. Operators and expressions

11.1 General

This clause describes the following:

- Expression semantics
- Operations on expressions
- Operator precedence
- Operand size extension rules
- Signed and unsigned operation rules
- Bit and part-select operations and longest static prefix
- Bit-stream operations
- Operator overloading

11.2 Overview

This clause describes the operators and operands available in SystemVerilog and how to use them to form expressions.

An *expression* is a construct that combines *operands* with *operators* to produce a result that is a function of the values of the operands and the semantic meaning of the operator. Any legal operand, such as a net bit-select, without any operator is considered an expression. Wherever a value is needed in a SystemVerilog statement, an expression can be used.

An *operand* can be one of the following:

- Constant literal number, including real literals
- String literal
- Parameter, including local and specify parameters
- Parameter bit-select or part-select, including local and specify parameters
- Net (see [6.7](#))
- Net bit-select or part-select
- Variable (see [6.8](#))
- Variable bit-select or part-select
- Structure, either packed or unpacked
- Structure member
- Packed structure bit-select or part-select
- Union, packed, unpacked, or tagged
- Union member
- Packed union bit-select or part-select
- Array, either packed or unpacked
- Packed array bit-select, part-select, element, or slice
- Unpacked array element bit-select or part-select, element, or slice
- A call to a user-defined function, system-defined function or method that returns any of the above

11.2.1 Constant expressions

Some statement constructs require an expression to be a *constant expression*. The operands of a constant expression consist of constant numbers, strings, parameters, constant bit-selects and part-selects of parameters, *constant function calls* (see [13.4.3](#)), and *constant system function calls* only. Constant expressions can use any of the operators defined in [Table 11-1](#).

Constant system function calls are calls to certain built-in system functions where the arguments meet conditions outlined in this subclause. When used in constant expressions, these function calls shall be evaluated at elaboration time. The system functions that may be used in constant system function calls are *pure functions*, i.e., those whose value depends only on their input arguments and which have no side effects.

Certain built-in system functions where the arguments are constant expressions are constant system function calls. Specifically, these are the conversion system functions listed in [20.5](#) and the mathematical system functions listed in [20.8](#).

The data query system functions listed in [20.6](#) and the array query system functions listed in [20.7](#) are normally also constant system function calls even when their arguments are not constant. See those sections for the conditions under which these query system function calls are considered to be constant expressions.

11.2.2 Aggregate expressions

Unpacked structure and array data objects, as well as unpacked structure and array constructors, can all be used as aggregate expressions. A multi-element slice of an unpacked array can also be used as an aggregate expression.

Aggregate expressions can be copied in an assignment, through a port, or as an argument to a subroutine. Aggregate expressions can also be compared with equality or inequality operators.

If the two operands of a comparison operator are aggregate expressions, they shall be of equivalent type as defined in [6.22.2](#). Assignment compatibility of aggregate expressions is defined in [6.22.3](#) and, for arrays, in [7.6](#).

11.3 Operators

The symbols for the SystemVerilog operators are similar to those in the C programming language. [Syntax 11-1](#) and [Table 11-1](#) list these operators.

```

assignment_operator ::=                                     // from A.6.2
    = | += | -= | *= | /= | %= | &= | |= | ^= | <<= | >>= | <<<= | >>>=
conditional_expression ::=                                 // from A.8.3
    cond_predicate ? { attribute_instance } expression : expression
unary_operator ::=                                       // from A.8.6
    + | - | ! | ~ | & | ~& | | | ~ | ^ | ~^ | ^~
binary_operator ::=
    + | - | * | / | % | == | != | === | !== | ==? | !=? | && | || | **
    | < | <= | > | >= | & | | | ^ | ^~ | ~^ | >> | << | >>> | <<<<
    | -> | <->
inc_or_dec_operator ::= ++ | --
stream_operator ::= >> | <<                                     // from A.8.1

```

Syntax 11-1—Operator syntax (excerpt from [Annex A](#))

Table 11-1—Operators and data types

Operator token	Name	Operand data types
=	binary assignment operator	any
+= -= /= *=	binary arithmetic assignment operators	integral, real , shortreal
%=	binary arithmetic modulus assignment operator	integral
&= = ^=	binary bit-wise assignment operators	integral
>>= <<=	binary logical shift assignment operators	integral
>>>= <<<=	binary arithmetic shift assignment operators	integral
?:	conditional operator	any
+ -	unary arithmetic operators	integral, real , shortreal
!	unary logical negation operator	integral, real , shortreal
~ & ~& ~ ^ ~^ ^~	unary logical reduction operators	integral
+ - * / **	binary arithmetic operators	integral, real , shortreal
%	binary arithmetic modulus operator	integral
& ^ ^~ ~^	binary bit-wise operators	integral
>> <<	binary logical shift operators	integral
>>> <<<	binary arithmetic shift operators	integral
&& -> <->	binary logical operators	integral, real , shortreal
< <= > >=	binary relational operators	integral, real , shortreal
=== !=	binary case equality operators	any except real and shortreal
== !=	binary logical equality operators	any
==? !=?	binary wildcard equality operators	integral
++ --	unary increment, decrement operators	integral, real , shortreal
inside	binary set membership operator	singular for the left operand
dist ^a	binary distribution operator	integral
{ } {{}}	concatenation, replication operators	integral
{<<{}} {>>{}}	stream operators	integral

^aThe **dist** operator is described in [16.15.2](#) (Assume statement) and [18.5.4](#) (Distribution).

11.3.1 Operators with real operands

[Table 11-1](#), above, shows what operators may be applied to real operands.

The result of using logical or relational operators or the **inside** operator on real operands shall be a single-bit scalar value.

For other operators, if any operand, except before the ? in the conditional operator, is **real**, the result is **real**. Otherwise, if any operand, except before the ? in the conditional operator, is **shortreal**, the result is **shortreal**.

Real operands can also be used in the following expressions:

```
str.realval // structure or union member
realarray[intval] // array element
```

See [6.12.1](#) for more information on use of real numbers.

11.3.2 Operator precedence

Operator precedence and associativity are listed in [Table 11-2](#). The highest precedence is listed first.

Table 11-2—Operator precedence and associativity

Operator	Associativity	Precedence
() [] :: .	left	highest  lowest
+ - ! ~ & ~& ~ ^ ~^ ^~ ++ -- (unary)		
**	left	
* / %	left	
+ - (binary)	left	
<< >> <<< >>>	left	
< <= > >= inside dist	left	
== != === !== ==? !=?	left	
& (binary)	left	
^ ~^ ^~ (binary)	left	
(binary)	left	
&&	left	
	left	
?: (conditional operator)	right	
-> <->	right	
= += -= *= /= %= &= ^= = <<= >>= <<<= >>>= := :/ <=	none	
{ } { }	concatenation	

Operators shown on the same row in [Table 11-2](#) shall have the same precedence. Rows are arranged in order of decreasing precedence for the operators. For example, *, /, and % all have the same precedence, which is higher than that of the binary + and – operators.

All operators shall associate left to right with the exception of the conditional (?:), implication (->), and equivalence (<->) operators, which shall associate right to left. Associativity refers to the order in which the operators having the same precedence are evaluated. Thus, in the following example, B is added to A, and then C is subtracted from the result of A+B.

A + B - C

When operators differ in precedence, the operators with higher precedence shall associate first. In the following example, B is divided by C (division has higher precedence than addition), and then the result is added to A.

A + B / C

Parentheses can be used to change the operator precedence.

(A + B) / C // not the same as A + B / C

11.3.3 Using integer literals in expressions

Integer literals can be used as operands in expressions. An integer literal can be expressed as

- An unsized, unbased integer (e.g., 12)
- An unsized, based integer (e.g., 'd12, 'sd12)
- A sized, based integer (e.g., 16'd12, 16'sd12)

See [5.7.1](#) for integer literal syntax.

A negative value for an integer with no base specifier shall be interpreted differently from an integer with a base specifier. An integer with no base specifier shall be interpreted as a signed value in twos-complement form. An integer with an unsigned base specifier shall be interpreted as an unsigned value.

The following example shows four ways to write the expression “minus 12 divided by 3.” Note that -12 and -'d12 both evaluate to the same twos-complement bit pattern, but, in an expression, the -'d12 loses its identity as a signed negative number.

```
int IntA;
IntA = -12 / 3; // The result is -4

IntA = -'d 12 / 3; // The result is 1431655761

IntA = -'sd 12 / 3; // The result is -4

IntA = -4'sd 12 / 3; // -4'sd12 is the negative of the 4-bit
// quantity 1100, which is -4. -(-4) = 4
// The result is 1
```

11.3.4 Operations on logic (4-state) and bit (2-state) types

Operators may be applied to 2-state values or to a mixture of 2-state and 4-state values. The result is the same as if all values were treated as 4-state values. In most cases, if all operands are 2-state, the result is in the 2-state value set. The only exceptions involve operators which produce an x result for operands in the 2-state value set (e.g., division by zero).

```
int n = 8, zero = 0;
int res = 'b01xz | n; // res gets 'b11xz coerced to int, or 'b1100
int sum = n + n; // sum gets 16 coerced to int, or 16
int sumx = 'x + n; // sumx gets 'x coerced to int, or 0
int div2 = n/zero + n; // div2 gets 'x coerced to int, or 0
integer div4 = n/zero + n; // div4 gets 'x
```

11.3.5 Operator expression short circuiting

The operators shall follow the associativity rules while evaluating an expression as described in [11.3.2](#). Some operators (&&, ||, ->, and ?:) shall use *short circuit evaluation*; in other words, some of their operand expressions shall not be evaluated if their value is not required to determine the final value of the operation. The detailed short circuiting behavior of each of these operators is described in its corresponding section ([11.4.7](#) and [11.4.11](#)). All other operators shall not use short circuit evaluation—all of their operand expressions are always evaluated. When short circuiting occurs, any side effects or runtime errors that would have occurred due to evaluation of the short circuited operand expression shall not occur.

For example:

```
logic regA, regB, regC, result ;

function logic myFunc(logic x);
    ...
endfunction

result = regA & (regB | myFunc(regC)) ;
```

Even if `regA` is known to be zero, the subexpression `(regB | myFunc(regC))` will be evaluated and any side effects caused by calling `myFunc(regC)` will occur.

Note that implementations are free to optimize by omitting evaluation of subexpressions as long as the simulation behavior (including side effects) is as if the standard rules were followed.

11.3.6 Assignment within an expression

An expression can include a blocking assignment, provided it does not have a timing control. These blocking assignments shall be enclosed in parentheses to avoid common mistakes such as using `a=b` for `a==b` or using `a|=b` for `a!=b`.

```
if ((a=b)) b = (a+=1);

a = (b = (c = 5));
```

The semantics of such an assignment expression is that of a function that evaluates the right-hand side, casts the right-hand side to the left-hand data type, stacks it, updates the left-hand side, and returns the stacked value. The data type of the value that is returned is the data type of the left-hand side. If the left-hand side is a concatenation, then the data type of the value that is returned shall be an unsigned integral data type whose bit length is the sum of the length of its operands.

It shall be illegal to include an assignment operator in an event expression, in an expression within a procedural continuous assignment, or in an expression that is not within a procedural statement.

11.4 Operator descriptions

11.4.1 Assignment operators

In addition to the simple assignment operator, `=`, SystemVerilog includes the C assignment operators and special bitwise assignment operators: `+=`, `-=`, `*=`, `/=`, `%=`, `&=`, `|=`, `^=`, `<<=`, `>>=`, `<<<=`, and `>>>=`. An assignment operator is semantically equivalent to a blocking assignment, with the exception that any left-hand index expression is only evaluated once. For example:

```
a[i]+=2; // same as a[i] = a[i] +2;
```

11.4.2 Increment and decrement operators

SystemVerilog includes the C increment and decrement assignment operators `++i`, `--i`, `i++`, and `i--`. These do not need parentheses when used in expressions. These increment and decrement assignment operators behave as blocking assignments.

The ordering of assignment operations relative to any other operation within an expression is undefined. An implementation can warn whenever a variable is both written and read-or-written within an integral expression or in other contexts where an implementation cannot guarantee order of evaluation. For example:

```
i = 10;
j = i++ + (i = i - 1);
```

After execution, the value of `j` can be 18, 19, or 20 depending upon the relative ordering of the increment and the assignment statements.

The increment and decrement operators, when applied to real operands, increment or decrement the operand by 1.0.

11.4.3 Arithmetic operators

The binary arithmetic operators are given in [Table 11-3](#).

Table 11-3—Arithmetic operators defined

<code>a + b</code>	a plus b
<code>a - b</code>	a minus b
<code>a * b</code>	a multiplied by b (or a times b)
<code>a / b</code>	a divided by b
<code>a % b</code>	a modulo b
<code>a ** b</code>	a to the power of b

The integer division shall truncate any fractional part toward zero. For the division or modulus operators, if the second operand is a zero, then the entire result value shall be ∞ . The modulus operator (for example, `a % b`) gives the remainder when the first operand is divided by the second and thus is zero when `b` divides `a` exactly. The result of a modulus operation shall take the sign of the first operand.

If either operand of the power operator is real, then the result type shall be real (see [11.3.1](#)). The result of the power operator is unspecified if the first operand is zero and the second operand is nonpositive or if the first operand is negative and the second operand is not an integral value.

If neither operand of the power operator is real, then the result type shall be determined as outlined in [11.6.1](#) and [11.8.1](#). The result value is ∞ if the first operand is zero and the second operand is negative. The result value is 1 if the second operand is zero.

In all cases, the second operand of the power operator shall be treated as self-determined.

These statements are illustrated in [Table 11-4](#).

Table 11-4—Power operator rules

	op1 is negative < -1	op1 is -1	op1 is zero	op1 is 1	op1 is positive > 1
op2 is positive	op1 ** op2	op2 is odd -> -1 op2 is even -> 1	0	1	op1 ** op2
op2 is zero	1	1	1	1	1
op2 is negative	0	op2 is odd -> -1 op2 is even -> 1	'x	1	0

The unary arithmetic operators shall take precedence over the binary operators. The unary operators are given in [Table 11-5](#).

Table 11-5—Unary operators defined

+m	Unary plus m (same as m)
-m	Unary minus m

For the arithmetic operators, if any operand bit value is the unknown value x or the high-impedance value z, then the entire result value shall be x.

[Table 11-6](#) gives examples of some modulus and power operations.

Table 11-6—Examples of modulus and power operators

Expression	Result	Comments
10 % 3	1	10/3 yields a remainder of 1.
11 % 3	2	11/3 yields a remainder of 2.
12 % 3	0	12/3 yields no remainder.
-10 % 3	-1	The result takes the sign of the first operand.
11 % -3	2	The result takes the sign of the first operand.
-4'd12 % 3	1	-4'd12 is seen as a large positive number that leaves a remainder of 1 when divided by 3.
3 ** 2	9	3 × 3
2 ** 3	8	2 × 2 × 2
2 ** 0	1	Anything to the zero exponent is 1.
0 ** 0	1	Zero to the zero exponent is also 1.
2.0 ** -3'sb1	0.5	2.0 is real, giving real reciprocal.
2 ** -3 'sb1	0	2 ** -1 = 1/2. Integer division truncates to zero.
0 ** -1	'x	0 ** -1 = 1/0. Integer division by zero is 'x.
9 ** 0.5	3.0	Real square root.

Table 11-6—Examples of modulus and power operators (continued)

Expression	Result	Comments
9.0 ** (1/2)	1.0	Integer division truncates exponent to zero.
-3.0 ** 2.0	9.0	Defined because real 2.0 is still integral value.

11.4.3.1 Arithmetic expressions with unsigned and signed types

Nets and variables can be explicitly declared as unsigned or signed. The **byte**, **shortint**, **int**, **integer**, and **longint** data types are signed by default. Other data types are unsigned by default.

A value assigned to an unsigned variable or net shall be treated as an *unsigned* value. A value assigned to a signed variable or net shall be treated as *signed*. Signed values, except for those assigned to real variables, shall use a twos-complement representation. Values assigned to real variables shall use a floating-point representation. Conversions between signed and unsigned values shall keep the same bit representation; only the interpretation changes.

[Table 11-7](#) lists how arithmetic operators interpret each data type.

Table 11-7—Data type interpretation by arithmetic operators

Data type	Interpretation
unsigned net	unsigned
signed net	signed, twos complement
unsigned variable	unsigned
signed variable	signed, twos complement
real variable	signed, floating point

The following example shows various ways to divide “minus twelve by three”—using **integer** and **logic** variables in expressions.

```

integer intS;
var logic [15:0] U;
var logic signed [15:0] S;

intS = -4'd12;
U = intS / 3;           // expression result is -4,
                       // intS is an integer data type, U is 65532

U = -4'd12;           // U is 65524
intS = U / 3;         // expression result is 21841,
                       // U is a logic data type

intS = -4'd12 / 3;    // expression result is 1431655761.
                       // -4'd12 is effectively a 32-bit logic data type

U = -12 / 3;          // expression result is -4, -12 is effectively
                       // an integer data type. U is 65532

S = -12 / 3;          // expression result is -4. S is a signed logic
    
```

```
S = -4'sd12 / 3;    // expression result is 1. -4'sd12 is actually 4.
                   // The rules for integer division yield 4/3==1
```

11.4.4 Relational operators

[Table 11-8](#) lists and defines the relational operators.

Table 11-8—Definitions of relational operators

a < b	a less than b
a > b	a greater than b
a <= b	a less than or equal to b
a >= b	a greater than or equal to b

An expression using these *relational operators* shall yield the scalar value 0 if the specified relation is false or the value 1 if it is true. If either operand of a relational operator contains an unknown (x) or high-impedance (z) value, then the result shall be a 1-bit unknown value (x).

When one or both operands of a relational expression are unsigned, the expression shall be interpreted as a comparison between unsigned values. If the operands are of unequal bit lengths, the smaller operand shall be zero-extended to the size of the larger operand.

When both operands are signed, the expression shall be interpreted as a comparison between signed values. If the operands are of unequal bit lengths, the smaller operand shall be sign-extended to the size of the larger operand. See [11.8.2](#) for more information.

If either operand is a real operand, then the other operand shall be converted to an equivalent real value and the expression shall be interpreted as a comparison between real values.

All the relational operators shall have the same precedence. Relational operators shall have lower precedence than arithmetic operators.

The following examples illustrate the implications of this precedence rule:

```
a < b - 1          // this expression is the same as
a < (b - 1)       // this expression, but . . .
b - (1 < a)       // this one is not the same as
b - 1 < a         // this expression
```

When `b - (1 < a)` evaluates, the relational expression evaluates first, and then either zero or one is subtracted from `b`. When `b - 1 < a` evaluates, the value of `b` operand is reduced by one and then compared with `a`.

11.4.5 Equality operators

The *equality operators* shall rank lower in precedence than the relational operators. [Table 11-9](#) lists and defines the equality operators.

Table 11-9—Definitions of equality operators

a === b	a equal to b, including x and z
a !== b	a not equal to b, including x and z
a == b	a equal to b, result can be unknown
a != b	a not equal to b, result can be unknown

All four equality operators shall have the same precedence. These four operators compare operands bit for bit. As with the relational operators, the result shall be 0 if comparison fails and 1 if it succeeds.

When one or both operands are unsigned, the expression shall be interpreted as a comparison between unsigned values. If the operands are of unequal bit lengths, the smaller operand shall be zero-extended to the size of the larger operand.

When both operands are signed, the expression shall be interpreted as a comparison between signed values. If the operands are of unequal bit lengths, the smaller operand shall be sign-extended to the size of the larger operand. See [11.8.2](#) for more information.

If either operand is a real operand, then the other operand shall be converted to an equivalent real value, and the expression shall be interpreted as a comparison between real values.

The logical equality (or case equality) operator is a legal operation if either operand is a class object or the literal `null`, and one of the operands is assignment compatible with the other. The logical equality (or case equality) operator is a legal operation if either operand is a `chandle` or the literal `null`. In both cases, the operator compares the values of the class objects or chandles.

For the *logical equality* and *logical inequality* operators (`==` and `!=`), if, due to unknown or high-impedance bits in the operands, the relation is ambiguous, then the result shall be a 1-bit unknown value (`x`).

For the *case equality* and *case inequality* operators (`===` and `!==`), the comparison shall be done just as it is in the procedural case statement (see [12.5](#)). Bits that are `x` or `z` shall be included in the comparison and shall match for the result to be considered equal. The result of these operators shall always be a known value, either 1 or 0.

11.4.6 Wildcard equality operators

The *wildcard equality operators* shall have the same precedence as the equality operators. [Table 11-10](#) lists and defines the wildcard equality operators.

Table 11-10—Wildcard equality and wildcard inequality operators

Operator	Usage	Description
<code>==?</code>	a ==? b	a equals b, X and Z values in b act as wildcards
<code>!=?</code>	a !=? b	a does not equal b, X and Z values in b act as wildcards

The wildcard equality operator (`==?`) and inequality operator (`!=?`) treat `x` and `z` values in a given bit position of their right operand as a wildcard. `x` and `z` values in the left operand are not treated as wildcards. A wildcard bit matches any bit value (0, 1, Z, or X) in the corresponding bit of the left operand being compared against it. Any other bits are compared as for the logical equality and logical inequality operators.

These operators compare operands bit for bit and return a 1-bit self-determined result. If the operands to the wildcard equality/inequality are of unequal bit length, the operands are extended in the same manner as for the logical equality/inequality operators. If the relation is true, the operator yields a 1. If the relation is false, it yields a 0. If the relation is unknown, it yields X.

The different types of equality (and inequality) operators in SystemVerilog behave differently when their operands contain unknown values (`x` or `z`). The `==` and `!=` operators may result in `x` if any of their operands contains an `x` or `z`. The `===` and `!==` operators explicitly check for 4-state values; therefore, `x` and `z` values shall either match or mismatch, never resulting in `x`. The `==?` and `!=?` operators may result in `x` if the left operand contains an `x` or `z` that is not being compared with a wildcard in the right operand.

The wildcard equality operator is equivalent to the logical equality operator if its operands are class objects, handles or the literal `null`.

11.4.7 Logical operators

The operators *logical and* (`&&`), *logical or* (`||`), *logical implication* (`->`), and *logical equivalence* (`<->`) are logical connectives. The result of the evaluation of a logical operation shall be 1 (defined as true), 0 (defined as false), or, if the result is ambiguous, the unknown value (`x`). The precedence of `&&` is greater than that of `||`, and both are lower than relational and equality operators. The precedence of `->` and `<->` is at the same level, the binding of operands between the two operations is governed by associativity (right), both are lower than other logical operators and the conditional operator.

The logical implication `expression1 -> expression2` is logically equivalent to `(!expression1 || expression2)`, and the logical equivalence `expression1 <-> expression2` is logically equivalent to `((expression1 -> expression2) && (expression2 -> expression1))`. Each of the two operands of the logical equivalence operator shall be evaluated exactly once.

The unary *logical negation* operator (`!`) converts a nonzero or true operand into 0 and a zero or false operand into 1. An ambiguous truth value remains as `x`.

Example 1—If variable `alpha` holds the integer value 237 and `beta` holds the value zero, then the following examples perform as described:

```
regA = alpha && beta;    // regA is set to 0
regB = alpha || beta;   // regB is set to 1
```

Example 2—The following expression performs a logical and of three subexpressions without needing any parentheses:

```
a < size-1 && b != c && index != lastone
```

However, it is recommended for readability purposes that parentheses be used to show very clearly the precedence intended, as in the following rewrite of this example:

```
(a < size-1) && (b != c) && (index != lastone)
```

Example 3—A common use of ! is in constructions like the following:

```
if (!inword)
```

In some cases, the preceding construct makes more sense to someone reading the code than this equivalent construct:

```
if (inword == 0)
```

The && and || operators shall use short circuit evaluation as follows:

- The first operand expression shall always be evaluated.
- For &&, if the first operand value is logically false then the second operand shall not be evaluated.
- For ||, if the first operand value is logically true then the second operand shall not be evaluated.

11.4.8 Bitwise operators

The *bitwise operators* shall perform bitwise manipulations on the operands; that is, the operator shall combine a bit in one operand with its corresponding bit in the other operand to calculate 1 bit for the result. [Table 11-11](#) through [Table 11-15](#) show the results for each possible calculation.

Table 11-11—Bitwise binary and operator

&	0	1	x	z
0	0	0	0	0
1	0	1	x	x
x	0	x	x	x
z	0	x	x	x

Table 11-12—Bitwise binary or operator

	0	1	x	z
0	0	1	x	x
1	1	1	1	1
x	x	1	x	x
z	x	1	x	x

Table 11-13—Bitwise binary exclusive or operator

\wedge	0	1	x	z
0	0	1	x	x
1	1	0	x	x
x	x	x	x	x
z	x	x	x	x

Table 11-14—Bitwise binary exclusive nor operator

$\wedge\sim$ $\sim\wedge$	0	1	x	z
0	1	0	x	x
1	0	1	x	x
x	x	x	x	x
z	x	x	x	x

Table 11-15—Bitwise unary negation operator

\sim	
0	1
1	0
x	x
z	x

11.4.9 Reduction operators

The *unary reduction operators* shall perform a bitwise operation on a single operand to produce a single-bit result. For *reduction and*, *reduction or*, and *reduction xor* operators, the first step of the operation shall apply the operator between the first bit of the operand and the second using [Table 11-16](#) through [Table 11-18](#). The second and subsequent steps shall apply the operator between the 1-bit result of the prior step and the next bit of the operand using the same logic table. For *reduction nand*, *reduction nor*, and *reduction xnor* operators, the result shall be computed by inverting the result of the reduction and, reduction or, and reduction xor operation, respectively.

Table 11-16—Reduction unary and operator

&	0	1	x	z
0	0	0	0	0
1	0	1	x	x
x	0	x	x	x
z	0	x	x	x

Table 11-17—Reduction unary or operator

 	0	1	x	z
0	0	1	x	x
1	1	1	1	1
x	x	1	x	x
z	x	1	x	x

Table 11-18—Reduction unary exclusive or operator

^	0	1	x	z
0	0	1	x	x
1	1	0	x	x
x	x	x	x	x
z	x	x	x	x

For example, [Table 11-19](#) shows the results of applying reduction operators on different operands.

Table 11-19—Results of unary reduction operations

Operand	&	~&		~	^	~^	Comments
4'b0000	0	1	0	1	0	1	No bits set
4'b1111	1	0	1	0	0	1	All bits set
4'b0110	0	1	1	0	0	1	Even number of bits set
4'b1000	0	1	1	0	1	0	Odd number of bits set

11.4.10 Shift operators

There are two types of *shift operators*: the logical shift operators, << and >>, and the arithmetic shift operators, <<< and >>>. The left shift operators, << and <<<, shall shift their left operand to the left by the number of bit positions given by the right operand. In both cases, the vacated bit positions shall be filled with zeros. The right shift operators, >> and >>>, shall shift their left operand to the right by the number of bit positions given by the right operand. The logical right shift shall fill the vacated bit positions with zeros. The arithmetic right shift shall fill the vacated bit positions with zeros if the result type is unsigned. It shall fill the vacated bit positions with the value of the most significant (i.e., *sign*) bit of the left operand if the result type is signed. If the right operand has an x or z value, then the result shall be unknown. The right operand is always treated as an unsigned number and has no effect on the signedness of the result. The result signedness is determined by the left-hand operand and the remainder of the expression, as outlined in [11.8.1](#).

Example 1—In this example, the variable `result` is assigned the binary value 0100, which is 0001 shifted to the left two positions and zero-filled.

```

module shift;
  logic [3:0] start, result;
  initial begin
    start = 1;
    result = (start << 2);
  end
endmodule

```

Example 2—In this example, the variable `result` is assigned the binary value 1110, which is 1000 shifted to the right two positions and sign-filled.

```

module ashift;
  logic signed [3:0] start, result;
  initial begin
    start = 4'b1000;
    result = (start >>> 2);
  end
endmodule

```

11.4.11 Conditional operator

The *conditional operator* shall be right associative and shall be constructed using three operands separated by two operators in the format given in [Syntax 11-2](#).

```

conditional_expression ::=                                     //from A.8.3
    cond_predicate ? { attribute_instance } expression : expression
cond_predicate ::=                                         //from A.6.6
    expression_or_cond_pattern { &&& expression_or_cond_pattern }
expression_or_cond_pattern ::=
    expression | cond_pattern
cond_pattern ::= expression matches pattern
    
```

Syntax 11-2—Conditional operator syntax (excerpt from [Annex A](#))

This subclause describes the traditional notation where *cond_predicate* is just a single expression. System-Verilog also allows *cond_predicate* to perform pattern matching, which is described in [12.6](#).

If *cond_predicate* is true, the operator returns the value of the first *expression* without evaluating the second expression; if false, it returns the value of the second *expression* without evaluating the first expression. If *cond_predicate* evaluates to an ambiguous value (x or z), then both the first *expression* and the second *expression* shall be evaluated, and their results shall be combined bit by bit using [Table 11-20](#) to calculate the final result unless either the first or second expression is real, in which case the result shall be 0. The first and second expressions are extended to the same width, as described in [11.6.1](#) and [11.8.2](#).

Table 11-20—Ambiguous condition results for conditional operator

?:	0	1	x	z
0	0	x	x	x
1	x	1	x	x
x	x	x	x	x
z	x	x	x	x

The following example of a three-state output bus illustrates a common use of the conditional operator:

```
wire [15:0] busa = drive_busa ? data : 16'bz;
```

The bus called *data* is driven onto *busa* when *drive_busa* is 1. If *drive_busa* is unknown, then an unknown value is driven onto *busa*. Otherwise, *busa* is not driven.

The conditional operator can be used with nonintegral types (see [6.11.1](#)) and aggregate expressions (see [11.2.2](#)) using the following rules:

- If both the first *expression* and second *expression* are of integral types, the operation proceeds as defined.
- If the first *expression* or second *expression* is an integral type and the opposing expression can be implicitly cast to an integral type, the cast is made and proceeds as defined.
- If the first *expression* or second *expression* is a class data type, the condition expression is legal in the following cases:

- a) If both first *expression* and second *expression* are the literal value **null**, the result of the entire conditional expression is as if the expression were the literal **null**.
- b) else, if either first *expression* or second *expression* is the literal **null**, the resulting type is the type of the non-null expression.
- c) else, if the first *expression* is assignment compatible with the second *expression*, the resulting type is the type of the second *expression*,
- d) else, if the second *expression* is assignment compatible with the first *expression*, the resulting type is the type of the first *expression*,
- e) else, if the first *expression* and second *expression* are of a class type deriving from a common base class type, the resulting type is the closest common inherited class type.

In the above cases, the resulting value is the value of the first *expression* if the condition evaluates to TRUE or the value of the second *expression* if the condition evaluates to FALSE.

- For all other cases, the type of the first *expression* and second *expression* shall be equivalent (see [6.22.2](#)).

For nonintegral and aggregate expressions, if *cond_predicate* evaluates to an ambiguous value, then:

- If the first *expression* and the second *expression* are of a class data type and if the conditional operation is legal, then the resulting type is determined as defined above and the result is null.
- Otherwise, both the first *expression* and second *expression* shall be evaluated, and their results shall be combined element by element. If the elements match, the element is returned. If they do not match, then the default-uninitialized value for that element's type shall be returned.

11.4.12 Concatenation operators

A concatenation is the result of the joining together of bits resulting from one or more expressions. The concatenation shall be expressed using the brace characters { and }, with commas separating the expressions within.

Unsize constant numbers shall not be allowed in concatenations. This is because the size of each operand in the concatenation is needed to calculate the complete size of the concatenation.

The following example concatenates four expressions:

```
{a, b[3:0], w, 3'b101}
```

The example above is equivalent to the following example:

```
{a, b[3], b[2], b[1], b[0], w, 1'b1, 1'b0, 1'b1}
```

The concatenation is treated as a packed vector of bits. It can be used on the left-hand side of an assignment or in an expression.

```
logic log1, log2, log3;  
{log1, log2, log3} = 3'b111;  
{log1, log2, log3} = {1'b1, 1'b1, 1'b1}; // same effect as 3'b111
```

One or more bits of a concatenation can be selected as if the concatenation were a packed array with the range [n-1:0]. Such a select shall not be legal as a *net_lvalue*, *variable_lvalue* or in any equivalent use, such as on the left-hand side of an assignment. Example:

```
byte a, b ;  
bit [1:0] c ;  
c = {a + b}[1:0]; // 2 lsb's of sum of a and b
```

A concatenation is not the same as a structure literal (see 5.10) or an array literal (see 5.11). Concatenations are enclosed in just braces ({ }), whereas structure and array literals are enclosed in braces that begin with an apostrophe (' { }).

11.4.12.1 Replication operator

A *replication* operator (also called a *multiple concatenation*) is expressed by a concatenation preceded by a non-negative, non-x and non-z constant expression, called a *replication constant*, enclosed together within brace characters. A replication indicates a joining together of that many copies of the concatenation. Unlike regular concatenations, expressions containing replications shall not appear on the left-hand side of an assignment and shall not be connected to **output** or **inout** ports.

This example replicates *w* four times.

```
{4{w}} // yields the same value as {w, w, w, w}
```

The following examples show illegal replications:

```
{1'bz{1'b0}} // illegal
{1'bx{1'b0}} // illegal
```

The next example illustrates a replication nested within a concatenation:

```
{b, {3{a, b}}} // yields the same value as {b, a, b, a, b, a, b}
```

A replication operation may have a replication constant with a value of zero. This is useful in parameterized code. A replication with a zero replication constant is considered to have a size of zero and is ignored. Such a replication shall appear only within a concatenation in which at least one of the operands of the concatenation has a positive size.

For example:

```
parameter P = 32;

// The following is legal for all P from 1 to 32

assign b[31:0] = { {32-P{1'b1}}, a[P-1:0] } ;

// The following is illegal for P=32 because the zero
// replication appears alone within a concatenation

assign c[31:0] = { {{32-P{1'b1}}}, a[P-1:0] }

// The following is illegal for P=32

initial
  $displayb({32-P{1'b1}}, a[P-1:0]);
```

When a replication expression is evaluated, the operands shall be evaluated exactly once, even if the replication constant is zero. For example:

```
result = {4{func(w)}} ;
```

would be computed as

```
y = func(w) ;  
result = {y, y, y, y} ;
```

11.4.12.2 String concatenation

A concatenation of data objects of type **string** is allowed. In general, if any of the operands is of the data type **string**, the concatenation is treated as a string, and all other arguments are implicitly converted to the **string** data type (as described in [6.16](#)). String concatenation is not allowed on the left-hand side of an assignment, only as an expression.

```
string hello = "hello";  
string s;  
s = { hello, " ", "world" };  
$display( "%s\n", s );           // displays 'hello world'  
s = { s, " and goodbye" };  
$display( "%s\n", s );           // displays 'hello world and goodbye'
```

The replication operator form of braces can also be used with data objects of type **string**. In the case of string replication, a non-constant multiplier is allowed.

```
int n = 3;  
string s = {n { "boo " }};  
$display( "%s\n", s ); // displays 'boo boo boo '
```

Unlike bit concatenation, the result of a string concatenation or replication is not truncated. Instead, the destination variable (of type **string**) is resized to accommodate the resulting string.

11.4.13 Set membership operator

SystemVerilog supports singular value sets and set membership operators.

The syntax for the set membership operator is as follows:

```
inside_expression ::= expression inside { open_range_list }           //from A.8.3
```

Syntax 11-3—Inside expression syntax (excerpt from [Annex A](#))

The *expression* on the left-hand side of the **inside** operator is any singular expression.

The set-membership *open_range_list* on the right-hand side of the **inside** operator is a comma-separated list of expressions or ranges. If an expression in the list is an unpacked array, its elements are traversed by descending into the array until reaching a singular value. The members of the set are scanned until a match is found and the operation returns 1'b1. Values can be repeated; therefore, values and value ranges can overlap. The order of evaluation of the expressions and ranges is nondeterministic.

```
int a, b, c;  
if ( a inside {b, c} ) ...  
int array [$] = '{3,4,5};  
if ( ex inside {1, 2, array} ) ... // same as { 1, 2, 3, 4, 5}
```

The **inside** operator uses the equality (==) operator on nonintegral expressions to perform the comparison. If no match is found, the **inside** operator returns 1'b0. Integral expressions use the wildcard equality (==?) operator so that an x or z bit in a value in the set is treated as a do-not-care in that bit position (see

[11.4.6](#)). As with wildcard equality, an x or z in the expression on the left-hand side of the inside operator is not treated as a do-not-care.

```
logic [2:0] val;
while ( val inside {3'b1?1} ) ... // matches 3'b101, 3'b111, 3'b1x1, 3'b1z1
```

If no match is found, but some of the comparisons result in x, the inside operator shall return 1'bx. The return value is effectively the or reduction of all the comparisons in the set with the expression on the left-hand side.

```
wire r;
assign r=3'bz11 inside {3'b1?1, 3'b011}; // r = 1'bx
```

A range can be specified with a low and high bound enclosed by square braces [] and separated by a colon (:), as in [low_bound:high_bound]. A bound specified by \$ shall represent the lowest or highest value for the type of the expression on the left-hand side. A match is found if the expression on the left-hand side is inclusively within the range. When specifying a range, the expressions shall be of a singular type for which the relation operators (<=, >=) are defined. If the bound to the left of the colon is greater than the bound to the right, the range is empty and contains no values.

For example:

```
bit ba = a inside { [16:23], [32:47] };
string I;
if ( I inside [{"a rock":"hard place"}] ) ...
    // I between "a rock" and a "hard place"
```

11.4.14 Streaming operators (pack/unpack)

The bit-stream casting described in [6.24.3](#) is most useful when the conversion operation can be easily expressed using only a type cast and the specific ordering of the bit stream is not important. Sometimes, however, a stream that matches a particular machine organization is required. The streaming operators perform packing of bit-stream types (see [6.24.3](#)) into a sequence of bits in a user-specified order. When used in the left-hand side, the streaming operators perform the reverse operation, i.e., unpack a stream of bits into one or more variables.

If the data being packed contains any 4-state types, the result of a pack operation is a 4-state stream; otherwise, the result of a pack is a 2-state stream. In the remainder of this subclause the word bit, without other qualification, denotes either a 2-state or a 4-state bit as required by this paragraph.

The syntax of the bit-stream concatenation is as follows:

```
streaming_concatenation ::= { stream_operator [ slice_size ] stream_concatenation } //from A.8.1
stream_operator ::= >> | <<
slice_size ::= simple_type | constant_expression
stream_concatenation ::= { stream_expression { , stream_expression } }
stream_expression ::= expression [ with [ array_range_expression ] ]
array_range_expression ::=
    expression
    | expression : expression
    | expression +: expression
    | expression -: expression
```

primary ::= // from [A.8.4](#)
...
| streaming_concatenation

Syntax 11-4—Streaming concatenation syntax (excerpt from [Annex A](#))

A *streaming_concatenation* (as specified in the syntax above) shall be used either as the target of an assignment, or as the source of an assignment, or as the operand of a bit-stream cast, or as a *stream_expression* in another *streaming_concatenation*. Use of *streaming_concatenation* as the target of an assignment, and the associated unpack operation, is described in [11.4.14.3](#) below.

It shall be an error to use a *streaming_concatenation* as an operand in an expression without first casting it to a bit-stream type. When a *streaming_concatenation* is used as the source of an assignment, the target of that assignment shall be either a data object of bit-stream type or a *streaming_concatenation*.

If the target is a data object of bit-stream type, the stream created by the source *streaming_concatenation* shall be implicitly cast to the type of the target. If this target represents a fixed-size variable and the stream is larger than the variable, an error will be generated. If the target variable is larger than the stream, the stream is left-aligned and zero-filled on the right. If the target represents a dynamically sized variable, such as a queue or dynamic array, the variable is resized to accommodate the entire stream. If, after resizing, the variable is larger than the stream, the stream is left-aligned and zero-filled on the right.

The pack operation performed by a *streaming_concatenation* is described in two steps for convenience, but the intermediate result between the two steps is never visible and therefore tools are free to implement it in any way that yields the same overall result. First, all integral data in the *stream_expressions* are concatenated into a single stream of bits, similarly to bit-stream casting (as described in [6.2.4.3](#)) but with fewer restrictions. Second, the resulting stream may be re-ordered in a manner specified by the *stream_operator* and *slice_size*. These two steps are described in more detail in [11.4.14.1](#) and [11.4.14.2](#) below.

11.4.14.1 Concatenation of stream_expressions

Each *stream_expression* within the *stream_concatenation*, starting with the leftmost and proceeding from left to right through the comma-separated list of *stream_expressions*, is converted to a bit-stream and appended to a packed array (*stream*) of bits, the *generic stream*, by recursively applying the following procedure:

- if the expression is a *streaming_concatenation* or it is of any bit-stream type,
 - it shall be cast to a packed array of bit using a bit-stream cast, including casting 2-state to 4-state if necessary, and that packed array shall then be appended to the right-hand end of the generic stream;
- else if the expression is an unpacked array (i.e. a queue, dynamic array, associative array or fixed-size unpacked array)
 - this procedure shall be applied in turn to each element of the array. An associative array is processed in index-sorted order. Other unpacked arrays are processed in the order in which they would be traversed by a **foreach** loop (see [12.7.3](#)) having exactly one index variable;
- else if the expression is of a struct type
 - this procedure shall be applied in turn to each element of the struct, in declaration order;
- else if the expression is of an untagged union type
 - this procedure shall be applied to the first-declared member of the union;
- else if the expression is a null class handle

the expression shall be skipped (not streamed), and a warning may be issued;

else if the expression is a non-null class handle

this procedure shall be applied in turn to each data member of the referenced object, and not the handle itself. Class members shall be streamed in declaration order. Extended class members shall be streamed after members of their base class. The result of streaming an object hierarchy that contains cycles shall be undefined, and an error may be issued. It shall be illegal to stream a class handle with local or protected members if those members would not be accessible at the point of the streaming operator;

else

the expression shall be skipped (not streamed), and an error shall be issued.

In the description above, the phrase *skipped* (not *streamed*) means that the expression in question is not appended to the stream, and operation of the procedure then proceeds with the next item in turn. Implementations are not required to continue the procedure after issuing an error.

11.4.14.2 Re-ordering of the generic stream

The stream resulting from the operation described in [11.4.14.1](#) is then re-ordered by slicing it into blocks and then re-ordering those blocks.

The *slice_size* determines the size of each block, measured in bits. If a *slice_size* is not specified, the default is 1. If specified, it may be a constant integral expression, or a simple type. If a type is used, the block size shall be the number of bits in that type. If a constant integral expression is used, it shall be an error for the value of the expression to be zero or negative.

The *stream_operator* << or >> determines the order in which blocks of data are streamed: >> causes blocks of data to be streamed in left-to-right order, while << causes blocks of data to be streamed in right-to-left order. Left-to-right streaming using >> shall cause the *slice_size* to be ignored, and no re-ordering performed. Right-to-left streaming using << shall reverse the order of blocks in the stream, preserving the order of bits within each block. For right-to-left streaming using <<, the stream is sliced into blocks with the specified number of bits, starting with the right-most bit. If as a result of slicing the last (left-most) block has fewer bits than the block size, the last block has the size of the remaining bits; there is no padding or truncation.

For example:

```
int j = { "A", "B", "C", "D" };
{ >> {j}} // generates stream "A" "B" "C" "D"
{ << byte {j}} // generates stream "D" "C" "B" "A" (little endian)
{ << 16 {j}} // generates stream "C" "D" "A" "B"
{ << { 8'b0011_0101 }} // generates stream 'b1010_1100 (bit reverse)
{ << 4 { 6'b11_0101 }} // generates stream 'b0101_11
{ >> 4 { 6'b11_0101 }} // generates stream 'b1101_01 (same)
{ << 2 { { << { 4'b1101 } } }} // generates stream 'b1110
```

11.4.14.3 Streaming concatenation as an assignment target (unpack)

When a *streaming_concatenation* appears as the target of an assignment, the streaming operators perform the reverse operation; i.e. to unpack a stream of bits into one or more variables. The source expression shall be of bit-stream type, or the result of another *streaming_concatenation*. If the source expression contains more bits than are needed, the appropriate number of bits shall be consumed from its left (most significant) end. However, if more bits are needed than are provided by the source expression, an error shall be generated.

Unpacking a 4-state stream into a 2-state target is done by casting to a 2-state type, and vice versa. Null handles are skipped by both the pack and unpack operations; therefore, the unpack operation shall not create class objects. If a particular object hierarchy is to be reconstructed from a stream, the object hierarchy into which the stream is to be unpacked must be created before the streaming operator is applied. The unpack operation shall only modify explicitly declared properties; it will not modify implicitly declared properties such as random modes (see [Clause 18](#)).

For example:

```

int a, b, c;
logic [10:0] up [3:0];
logic [11:1] p1, p2, p3, p4;
bit [96:1] y = {>>{ a, b, c }}; // OK: pack a, b, c
int j = {>>{ a, b, c }}; // error: j is 32 bits < 96 bits
bit [99:0] d = {>>{ a, b, c }}; // OK: d is padded with 4 bits
{>>{ a, b, c }} = 23'b1; // error: too few bits in stream
{>>{ a, b, c }} = 96'b1; // OK: unpack a = 0, b = 0, c = 1
{>>{ a, b, c }} = 100'b1; // OK: unpack as above (4 bits unread)
{ >> {p1, p2, p3, p4}} = up; // OK: unpack p1 = up[3], p2 = up[2],
// p3 = up[1], p4 = up[0]

```

11.4.14.4 Streaming dynamically sized data

If the unpack operation includes unbounded dynamically sized types, the process is greedy (as in a cast): the first dynamically sized item is resized to accept all the available data (excluding subsequent fixed-size items) in the stream; any remaining dynamically sized items are left empty. This mechanism is sufficient to unpack a packet-sized stream that contains only one dynamically sized data item. However, when the stream contains multiple variable-size data packets, or each data packet contains more than one variable-size data item, or the size of the data to be unpacked is stored in the middle of the stream, this mechanism can become cumbersome and error-prone. To overcome these problems, the unpack operation allows a **with** expression to explicitly specify the extent of a variable-size field within the unpack operation.

The syntax of the **with** expression is as follows:

```

stream_expression ::= expression [ with [ array_range_expression ] ] //from A.8.1
array_range_expression ::=
    expression
    | expression : expression
    | expression +: expression
    | expression -: expression

```

Syntax 11-5—With expression syntax (excerpt from [Annex A](#))

The array range expression within the **with** construct shall be of integral type and evaluate to values that lie within the bounds of a fixed-size array or to positive values for dynamic arrays or queues. The expression before the **with** can be any one-dimensional unpacked array (including a queue). The expression within the **with** is evaluated immediately before its corresponding array is streamed (i.e., packed or unpacked). Thus, the expression can refer to data that are unpacked by the same operator but before the array. If the expression refers to variables that are unpacked after the corresponding array (to the right of the array), then the expression is evaluated using the previous values of the variables.

When used within the context of an unpack operation and the array is a variable-size array, it shall be resized to accommodate the range expression. If the array is a fixed-size array and the range expression evaluates to

a range outside the extent of the array, only the range that lies within the array is unpacked and an error is generated. If the range expression evaluates to a range smaller than the extent of the array (fixed or variable size), only the specified items are unpacked into the designated array locations; the remainder of the array is unmodified.

When used within the context of a pack (on the right-hand side), it behaves the same as an array slice. The specified number of array items are packed into the stream. If the range expression evaluates to a range smaller than the extent of the array, only the specified array items are streamed. If the range expression evaluates to a range greater than the extent of the array size, the entire array is streamed, and the remaining items are generated using the default value (as described in [Table 7-1](#)) for the given array.

For example, the code below uses streaming operators to model a packet transfer over a byte stream that uses little-endian encoding:

```

byte stream[$]; // byte stream

class Packet;
    rand int header;
    rand int len;
    rand byte payload[];
    int crc;

    constraint G { len > 1; payload.size == len ; }

    function void post_randomize; crc = payload.sum; endfunction
endclass

...
send: begin // Create random packet and transmit
    byte q[$];
    Packet p = new;
    void'(p.randomize());
    q = {<< byte{p.header, p.len, p.payload, p.crc}}; // pack
    stream = {stream, q}; // append to stream
end

...
receive: begin // Receive packet, unpack, and remove
    byte q[$];
    Packet p = new;
    {<< byte{ p.header, p.len, p.payload with [0 +: p.len], p.crc }} = stream;
    stream = stream[ $bits(p) / 8 : $ ]; // remove packet
end

```

In the example above, the pack operation could have been written as either:

```
q = {<<byte{p.header, p.len, p.payload with [0 +: p.len], p.crc}};
```

or

```
q = {<<byte{p.header, p.len, p.payload with [0 : p.len-1], p.crc}};
```

or

```
q = {<<byte{p}};
```

The result in this case would be the same because `p.len` is the size of `p.payload` as specified by the constraint.

11.5 Operands

There are several types of operands that can be specified in expressions. The simplest type is a reference to a net, variable, or parameter in its complete form; that is, just the name of the net, variable, or parameter is given. In this case, all of the bits making up the net, variable, or parameter value shall be used as the operand.

If a single bit of a vector net, vector variable, packed array, packed structure or parameter is required, then a bit-select operand shall be used. A part-select operand shall be used to reference a group of adjacent bits in a vector net, vector variable, packed array, packed structure, or parameter.

An unpacked array element can be referenced as an operand.

A concatenation of other operands (including nested concatenations) can be specified as an operand.

A function call is an operand.

Each of the types of operands mentioned above is an example of a *simple operand*. An operand is simple if it is not parenthesized and is a *primary* as defined in [A.8.4](#). In the following example, the expressions `1'b1 - 2'b00` and `(1'b1 + 1'b1)` are operands, but are not simple operands.

```
1'b1 - 2'b00 + (1'b1 + 1'b1)
```

11.5.1 Vector bit-select and part-select addressing

Bit-selects extract a particular bit from a vector, packed array, packed structure, parameter, or concatenation. The bit can be addressed using an expression that shall be evaluated in a self-determined context. If the bit-select is out of the address bounds or the bit-select is `x` or `z`, then the value returned by the reference shall be `x`. A bit-select or part-select of a scalar, or of a real variable or real parameter, shall be illegal.

Several contiguous bits can be addressed and are known as *part-selects*. There are two types of part-selects, a *non-indexed part-select* and an *indexed part-select*. A *non-indexed part-select* is given with the following syntax:

```
vect[msb_expr:lsb_expr]
```

Both *msb_expr* and *lsb_expr* shall be constant integer expressions. Each of these expressions shall be evaluated in a self-determined context. The first expression shall address a more significant bit than the second expression.

An *indexed part-select* is given with the following syntax:

```
logic [15:0] down_vect;  
logic [0:15] up_vect;  
  
down_vect[lsb_base_expr +: width_expr]  
up_vect[msb_base_expr +: width_expr]  
  
down_vect[msb_base_expr -: width_expr]  
up_vect[lsb_base_expr -: width_expr]
```

The *msb_base_expr* and *lsb_base_expr* shall be integer expressions, and the *width_expr* shall be a positive constant integer expression. Each of these expressions shall be evaluated in a self-determined context. The *lsb_base_expr* and *msb_base_expr* can vary at run time. The first two examples select bits starting at the base and ascending the bit range. The number of bits selected is equal to the width expression. The second two examples select bits starting at the base and descending the bit range.

A *constant bit-select* is a bit-select whose position is constant. A *constant part-select* is a part-select whose position and width are both constant. The width of a part-select is always constant. Thus, a non-indexed part-select is always a constant part-select, and an indexed part-select is a constant part-select if its base is a constant value as well as its width.

A part-select that addresses a range of bits that are completely out of the address bounds of the vector, packed array, packed structure, parameter or concatenation, or a part-select that is *x* or *z* shall yield the value *x* when read and shall have no effect on the data stored when written. Part-selects that are partially out of range shall, when read, return *x* for the bits that are out of range and shall, when written, only affect the bits that are in range.

For example:

```

logic [31: 0] a_vect;
logic [0 :31] b_vect;
logic [63: 0] dword;
integer sel;

a_vect[ 0 +: 8]      // == a_vect[ 7 : 0]
a_vect[15 -: 8]      // == a_vect[15 : 8]

b_vect[ 0 +: 8]      // == b_vect[0 : 7]
b_vect[15 -: 8]      // == b_vect[8 :15]

dword[8*sel +: 8]    // variable part-select with fixed width

```

The following example specifies the single bit of vector *acc* that is addressed by the operand *index*:

```
acc[index]
```

The actual bit that is accessed by an address is, in part, determined by the declaration of *acc*. For instance, each of the declarations of *acc* shown in the next example causes a particular value of *index* to access a different bit:

```

logic [15:0] acc;
logic [2:17] acc;

```

The next example and the bullet items that follow it illustrate the principles of bit addressing. The code declares an 8-bit variable called *vect* and initializes it to a value of 4. The list describes how the separate bits of that vector can be addressed.

```

logic [7:0] vect;
vect = 4; // fills vect with the pattern 00000100
          // msb is bit 7, lsb is bit 0

```

- If the value of *addr* is 2, then *vect*[*addr*] returns 1.
- If the value of *addr* is out of bounds, then *vect*[*addr*] returns *x*.
- If *addr* is 0, 1, or 3 through 7, *vect*[*addr*] returns 0.
- *vect*[3:0] returns the bits 0100.

- `vect[5:1]` returns the bits 00010.
- `vect[expression that returns x]` returns `x`.
- `vect[expression that returns z]` returns `x`.
- If any bit of `addr` is `x` or `z`, then the value of `addr` is `x`.

NOTE 1—Part-select indices that evaluate to `x` or `z` may be flagged as a compile time error.

NOTE 2—Bit-select or part-select indices that are outside the declared range may be flagged as a compile time error.

11.5.2 Array and memory addressing

Declaration of arrays and memories (one-dimensional arrays of **reg**, **logic**, or **bit**) are discussed in [7.4](#). This subclause discusses array addressing.

The following example declares a memory of 1024 eight-bit words:

```
logic [7:0] mem_name[0:1023];
```

The syntax for a memory address shall consist of the name of the memory and an expression for the address, specified with the following format:

```
mem_name[addr_expr]
```

The *addr_expr* can be any integer expression; therefore, memory indirections can be specified in a single expression. The next example illustrates memory indirection:

```
mem_name[mem_name[3]]
```

In this example, `mem_name[3]` addresses word three of the memory called `mem_name`. The value at word three is the index into `mem_name` that is used by the memory address `mem_name[mem_name[3]]`. As with bit-selects, the address bounds given in the declaration of the memory determine the effect of the address expression. If the index is out of the address bounds or if any bit in the address is `x` or `z`, then the value of the reference shall be `x`.

The next example declares an array of 256-by-256 eight-bit elements and an array 256-by-256-by-8 one-bit elements:

```
logic [7:0] twod_array[0:255][0:255];  
wire threed_array[0:255][0:255][0:7];
```

The syntax for access to the array shall consist of the name of the memory or array and an integer expression for each addressed dimension:

```
twod_array[addr_expr][addr_expr]  
threed_array[addr_expr][addr_expr][addr_expr]
```

As before, the *addr_expr* can be any integer expression. The array `twod_array` accesses a whole 8-bit vector, while the array `threed_array` accesses a single bit of the three-dimensional array.

To express bit-selects or part-selects of array elements, the desired word shall first be selected by supplying an address for each dimension. Once selected, bit-selects and part-selects shall be addressed in the same manner as net and variable bit-selects and part-selects (see [11.5.1](#)).

For example:

```

twod_array[14][1][3:0]    // access lower 4 bits of word
twod_array[1][3][6]      // access bit 6 of word
twod_array[1][3][sel]    // use variable bit-select
threed_array[14][1][3:0] // Illegal

```

11.5.3 Longest static prefix

Informally, the *longest static prefix* of a select is the longest part of the select for which an analysis tool has known values following elaboration. This concept is used when describing implicit sensitivity lists (see [9.2.2.2](#)) and when describing error conditions for drivers of logic ports (see [6.5](#)). The remainder of this clause defines what constitutes the “longest static prefix” of a select.

A field select is defined as a hierarchical name where the right-hand side of the last “.” hierarchy separator identifies a field of a variable whose type is a **struct** or **union** declaration. The field select prefix is defined to be the left-hand side of the final “.” hierarchy separator in a field select.

An indexing select is a single indexing operation. The indexing select prefix is either an identifier or, in the case of a multidimensional select, another indexing select. Array selects, bit-selects, part-selects, and indexed part-selects are examples of indexing selects.

The definition of a static prefix is recursive and is defined as follows:

- An identifier is a static prefix.
- A hierarchical reference to an object is a static prefix.
- A package reference to net or variable is a static prefix.
- A field select is a static prefix if the field select prefix is a static prefix.
- An indexing select is a static prefix if the indexing select prefix is a static prefix and the select expression is a constant expression.

The definition of the longest static prefix is defined as follows:

- An identifier that is not the field select prefix or indexing select prefix of an expression that is a static prefix.
- A field select that is not the field select prefix or indexing select prefix of an expression that is a static prefix.
- An indexing select that is not the field select prefix or indexing select prefix of an expression that is a static prefix.

Examples:

```

localparam p = 7;
reg [7:0] m [5:1][5:1];
integer i;

m[1][i]    // longest static prefix is m[1]

m[p][1]    // longest static prefix is m[p][1]

m[i][1]    // longest static prefix is m

```

11.6 Expression bit lengths

The number of bits of an expression is determined by the operands and the context. Casting can be used to set the size context of an intermediate value (see [6.24](#)).

Controlling the number of bits that are used in expression evaluations is important if consistent results are to be achieved. Some situations have a simple solution; for example, if a bitwise and operation is specified on two 16-bit variables, then the result is a 16-bit value. However, in some situations, it is not obvious how many bits are used to evaluate an expression or what size the result should be.

For example, should an arithmetic add of two 16-bit values perform the evaluation using 16 bits, or should the evaluation use 17 bits in order to allow for a possible carry overflow? The answer depends on the type of device being modeled and whether that device handles carry overflow.

SystemVerilog uses the bit length of the operands to determine how many bits to use while evaluating an expression. The bit length rules are given in [11.6.1](#). In the case of the addition operator, the bit length of the largest operand, including the left-hand side of an assignment, shall be used.

For example:

```

logic [15:0] a, b;    // 16-bit variables
logic [15:0] sumA;   // 16-bit variable
logic [16:0] sumB;   // 17-bit variable

sumA = a + b;         // expression evaluates using 16 bits
sumB = a + b;         // expression evaluates using 17 bits
  
```

11.6.1 Rules for expression bit lengths

The rules governing the expression bit lengths have been formulated so that most practical situations have a natural solution.

The number of bits of an expression (known as the *size* of the expression) shall be determined by the operands involved in the expression and the context in which the expression is given.

A *self-determined expression* is one where the bit length of the expression is solely determined by the expression itself—for example, an expression representing a delay value.

A *context-determined expression* is one where the bit length of the expression is determined by the bit length of the expression and by the fact that it is part of another expression. For example, the bit size of the right-hand expression of an assignment depends on itself and the size of the left-hand side.

[Table 11-21](#) shows how the form of an expression shall determine the bit lengths of the results of the expression. In [Table 11-21](#), *i*, *j*, and *k* represent expressions of an operand, and $L(i)$ represents the bit length of the operand represented by *i*.

Table 11-21—Bit lengths resulting from self-determined expressions

Expression	Bit length	Comments
Unsize constant number	Same as integer	
Sized constant number	As given	
<i>i op j</i> , where op is: + - * / % & ^ ~ ^	$\max(L(i),L(j))$	
op <i>i</i> , where op is: + - ~	$L(i)$	
<i>i op j</i> , where op is: === !== == != > >= < <=	1 bit	Operands are sized to $\max(L(i),L(j))$

Table 11-21—Bit lengths resulting from self-determined expressions (continued)

Expression	Bit length	Comments
i op j, where op is: && -> <->	1 bit	All operands are self-determined
op i, where op is: & ~& ~ ^ ~^ ^~ !	1 bit	All operands are self-determined
i op j, where op is: >> << ** >>> <<<	L(i)	j is self-determined
i ? j : k	max(L(j),L(k))	i is self-determined
{i,...j}	L(i)+..+L(j)	All operands are self-determined
{i{j,...k}}	i × (L(j)+..+L(k))	All operands are self-determined

Multiplication may be performed without losing any overflow bits by assigning the result to something wide enough to hold it.

11.6.2 Example of expression bit-length problem

During the evaluation of an expression, interim results shall take the size of the largest operand (in case of an assignment, this also includes the left-hand side). Care has to be taken to prevent loss of a significant bit during expression evaluation. The example below describes how the bit lengths of the operands could result in the loss of a significant bit.

Given the following declarations:

```
logic [15:0] a, b, answer; // 16-bit variables
```

the intent is to evaluate the expression

```
answer = (a + b) >> 1; // will not work properly
```

where *a* and *b* are to be added, which can result in an overflow, and then shifted right by 1 bit to preserve the carry bit in the 16-bit answer.

A problem arises, however, because all operands in the expression are of a 16-bit width. Therefore, the expression $(a + b)$ produces an interim result that is only 16 bits wide, thus losing the carry bit before the evaluation performs the 1-bit right shift operation.

The solution is to force the expression $(a + b)$ to evaluate using at least 17 bits. For example, adding an integer value of 0 to the expression will cause the evaluation to be performed using the bit size of integers. The following example will produce the intended result:

```
answer = (a + b + 0) >> 1; // will work correctly
```

In the following example:

```
module bitlength();
  logic [3:0] a, b, c;
  logic [4:0] d;

  initial begin
```

```

    a = 9;
    b = 8;
    c = 1;
    $display("answer = %b", c ? (a&b) : d);
end
endmodule

```

the `$display` statement will display

```
answer = 01000
```

By itself, the expression `a&b` would have the bit length 4, but because it is in the context of the conditional expression, which uses the maximum bit length, the expression `a&b` actually has length 5, the length of `d`.

11.6.3 Example of self-determined expressions

```

logic [3:0] a;
logic [5:0] b;
logic [15:0] c;

initial begin
    a = 4'hF;
    b = 6'hA;
    $display("a*b=%h", a*b); // expression size is self-determined
    c = {a**b}; // expression a**b is self-determined
                    // due to concatenation operator {}
    $display("a**b=%h", c);
    c = a**b; // expression size is determined by c
    $display("c=%h", c);
end

```

Simulator output for this example:

```

a*b=16 // 'h96 was truncated to 'h16 since expression size is 6
a**b=1 // expression size is 4 bits (size of a)
c=ac61 // expression size is 16 bits (size of c)

```

11.7 Signed expressions

Controlling the sign of an expression is important if consistent results are to be achieved. [11.8.1](#) outlines the rules that determine if an expression is signed or unsigned.

The cast operator can be used to change either the signedness or type of an expression (see [6.24.1](#)). In addition to the cast operator, the `$signed` and `$unsigned` system functions are available for casting the signedness of expressions. These functions shall evaluate the input expression and return a one-dimensional packed array with the same number of bits and value of the input expression and the signedness defined by the function.

`$signed` — returned value is signed

`$unsigned` — returned value is unsigned

For example:

```

logic [7:0] regA, regB;
logic signed [7:0] regS;

```

```

regA = $unsigned(-4);           // regA = 8'b11111100
regB = $unsigned(-4'sd4);       // regB = 8'b00001100
regS = $signed (4'b1100);       // regS = -4

regA = unsigned'(-4);          // regA = 8'b11111100
regS = signed'(4'b1100);       // regS = -4

regS = regA + regB;             // will do unsigned addition
regS = byte'(regA) + byte'(regB); // will do signed addition
regS = signed'(regA) + signed'(regB); // will do signed addition
regS = $signed(regA) + $signed(regB); // will do signed addition

```

11.8 Expression evaluation rules

11.8.1 Rules for expression types

The following are the rules for determining the resulting type of an expression:

- Expression type depends only on the operands. It does not depend on the left-hand side (if any).
- Decimal numbers are signed.
- Based numbers are unsigned, except where the *s* notation is used in the base specifier (as in `4'sd12`).
- Bit-select results are unsigned, regardless of the operands.
- Part-select results are unsigned, regardless of the operands even if the part-select specifies the entire vector.

```

logic [15:0] a;
logic signed [7:0] b;

initial
    a = b[7:0]; // b[7:0] is unsigned and therefore zero-extended

```

- Concatenate results are unsigned, regardless of the operands.
- Comparison and reduction operator results are unsigned, regardless of the operands.
- Reals converted to integers by type coercion are signed
- The sign and size of any self-determined operand are determined by the operand itself and independent of the remainder of the expression.
- For non-self-determined operands, the following rules apply:
 - If any operand is real, the result is real.
 - If any operand is unsigned, the result is unsigned, regardless of the operator.
 - If all operands are signed, the result will be signed, regardless of operator, except when specified otherwise.

11.8.2 Steps for evaluating an expression

The following are the steps for evaluating an expression:

- Determine the expression size based upon the standard rules of expression size determination.
- Determine the sign of the expression using the rules outlined in [11.8.1](#).
- Propagate the type and size of the expression (or self-determined subexpression) back down to the context-determined operands of the expression. In general, any context-determined operand of an

operator shall be the same type and size as the result of the operator. However, there are two exceptions:

- If the result type of the operator is real and if it has a context-determined operand that is not real, that operand shall be treated as if it were self-determined and then converted to real just before the operator is applied.
- The relational and equality operators have operands that are neither fully self-determined nor fully context-determined. The operands shall affect each other as if they were context-determined operands with a result type and size (maximum of the two operand sizes) determined from them. However, the actual result type shall always be 1 bit unsigned. The type and size of the operand shall be independent of the rest of the expression and vice versa.
- When propagation reaches a simple operand as defined in 11.5, then that operand shall be converted to the propagated type and size. If the operand shall be extended, then it shall be sign-extended only if the propagated type is signed.

11.8.3 Steps for evaluating an assignment

The following are the steps for evaluating an assignment:

- Determine the size of the right-hand side by the standard assignment size determination rules (see 11.6).
- If needed, extend the size of the right-hand side, performing sign extension if, and only if, the type of the right-hand side is signed.

11.8.4 Handling X and Z in signed expressions

If a signed operand is to be resized to a larger signed width and the value of the sign bit is *x*, the resulting value shall be bit-filled with *x*. If the sign bit of the value is *z*, then the resulting value shall be bit-filled with *z*. If any bit of a signed value is *x* or *z*, then any nonlogical operation involving the value shall result in the entire resultant value being an *x* and the type consistent with the expression's type.

11.9 Tagged union expressions and member access

```
expression ::= // from A.8.3  
    ...  
    | tagged_union_expression  
tagged_union_expression ::=  
    tagged member_identifier [ expression ]
```

Syntax 11-6—Tagged union syntax (excerpt from [Annex A](#))

A tagged union expression (packed or unpacked) is expressed using the keyword **tagged** followed by a tagged union member identifier, followed by an expression representing the corresponding member value. For **void** members the member value expression is omitted.

Example:

```
typedef union tagged {  
    void Invalid;  
    int Valid;  
} VInt;
```

```
VInt vi1, vi2;

vi1 = tagged Valid (23+34); // Create Valid int
vi2 = tagged Invalid;     // Create an Invalid value
```

In the tagged union expressions below, the expressions in braces are structure assignment patterns (see [10.9.2](#)).

```
typedef union tagged {
    struct {
        bit [4:0] reg1, reg2, regd;
    } Add;
    union tagged {
        bit [9:0] JmpU;
        struct {
            bit [1:0] cc;
            bit [9:0] addr;
        } JmpC;
    } Jmp;
} Instr;

Instr i1, i2;

// Create an Add instruction with its 3 register fields
i1 = ( e
    ? tagged Add '{ e1, 4, ed }; // struct members by position
    : tagged Add '{ reg2:e2, regd:3, reg1:19 }; // by name (order irrelevant)

// Create a Jump instruction, with "unconditional" sub-opcode
i1 = tagged Jmp (tagged JmpU 239);

// Create a Jump instruction, with "conditional" sub-opcode
i2 = tagged Jmp (tagged JmpC '{ 2, 83 }); // inner struct by position
i2 = tagged Jmp (tagged JmpC '{ cc:2, addr:83 }); // by name
```

The type of a tagged union expression shall be known from its context (e.g., it is used in the right-hand side of an assignment to a variable whose type is known, or it has a cast, or it is used inside another expression from which its type is known). The expression evaluates to a tagged union value of that type. The tagged union expression can be completely type-checked statically: the only member names allowed after the **tagged** keyword are the member names for the expression type, and the member expression shall have the corresponding member type.

An uninitialized variable of tagged union type shall be undefined. This includes the tag bits. A variable of tagged union type can be initialized with a tagged union expression provided the member value expression is a legal initializer for the member type.

Members of tagged unions can be read or assigned using the usual dot notation. Such accesses are completely type-checked, i.e., the value read or assigned shall be consistent with the current tag. In general, this can require a run-time check. An attempt to read or assign a value whose type is inconsistent with the tag results in a run-time error.

All the following examples are legal only if the instruction variable `i1` currently has tag `Add`:

```
x = i1.Add.reg1;
i1.Add = '{19, 4, 3};
i1.Add.reg2 = 4;
```

11.10 String literal expressions

This subclause discusses operations on string literals (see [5.9](#)) and string literals stored in bit vectors and other packed types. SystemVerilog also has string variables, which store strings differently than vectors. The **string** data type has several special built-in methods for manipulating strings. See [6.16](#) for a discussion of the **string** data type and associated methods.

String literal operands shall be treated as constant numbers consisting of a sequence of 8-bit ASCII codes, one per character. Any SystemVerilog operator can manipulate string literal operands. The operator shall behave as though the entire string were a single numeric value.

When a vector is larger than required to hold the string literal value being assigned, the contents after the assignment shall be padded on the left with zeros. This is consistent with the padding that occurs during assignment of nonstring unsigned values.

The following example declares a vector variable large enough to hold 14 characters and assigns a value to it. The example then manipulates the stored value using the concatenation operator.

```
module string_test;
  bit [8*14:1] stringvar;

  initial begin
    stringvar = "Hello world";
    $display("%s is stored as %h", stringvar, stringvar);
    stringvar = {stringvar, "!!!"};
    $display("%s is stored as %h", stringvar, stringvar);
  end
endmodule
```

The result of simulating the above description is as follows:

```
Hello world is stored as 00000048656c6c6f20776f726c64
Hello world!!! is stored as 48656c6c6f20776f726c64212121
```

11.10.1 String literal operations

SystemVerilog operators support the common string operations *copy*, *concatenate*, and *compare* for string literals and string literals stored in vectors. Copy is provided by simple assignment. Concatenation is provided by the concatenation operator. Comparison is provided by the equality operators.

When manipulating string literal values in vectors, the vectors should be at least $8*n$ bits (where n is the number of ASCII characters) in order to preserve the 8-bit ASCII code.

11.10.2 String literal value padding and potential problems

When string literals are assigned to vectors, the values stored shall be padded on the left with zeros. Padding can affect the results of comparison and concatenation operations. The comparison and concatenation operators shall not distinguish between zeros resulting from padding and the original string characters ($\backslash 0$, ASCII NUL).

The following example illustrates the potential problem:

```
bit [8*10:1] s1, s2;
initial begin
  s1 = "Hello";
```

```

s2 = " world!";
if ({s1,s2} == "Hello world!")
    $display("strings are equal");
end

```

The comparison in this example fails because during the assignment the variables `s1` and `s2` are padded as illustrated in the next example:

```

s1 = 000000000048656c6c6f
s2 = 00000020776f726c6421

```

The concatenation of `s1` and `s2` includes the zero padding, resulting in the following value:

```
000000000048656c6c6f00000020776f726c6421
```

Because the string literal "Hello world!" contains no zero padding, the comparison fails, as shown in the following example:

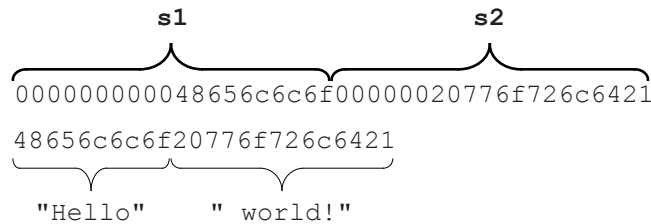

This comparison yields a result of zero, which represents false.

11.10.3 Null string literal handling

The null string literal ("") shall be considered equivalent to the ASCII NUL ("\0"), which has a value zero (0), which is different from a string "0".

11.11 Operator overloading

There are various kinds of arithmetic that can be useful: saturating, arbitrary size floating point, carry save, etc. It is convenient to use the normal arithmetic operators for readability, rather than relying on function calls.

```

overload_declaration ::= // from A.2.8
    bind overload_operator function data_type function_identifier ( overload_proto_formals ) ;
overload_operator ::= + | ++ | - | -- | * | ** | / | % | == | != | < | <= | > | >= | =
overload_proto_formals ::= data_type { , data_type }

```

Syntax 11-7—Operator overloading syntax (excerpt from [Annex A](#))

The overload declaration allows the arithmetic operators to be applied to data types that are normally illegal for them, such as unpacked structures. It does not change the meaning of the operators for data types where it is legal to apply them. In other words, such code does not change behavior when operator overloading is used.

The overload declaration links an operator to a function prototype. The arguments are matched, and the data type of the result is then checked. Multiple functions can have the same arguments and different return data types. If no expected data type exists because the operator is in a self-determined context, then a cast shall be used to select the correct function. Similarly if more than one expected data type is possible, due to nested operators, and could match more than one function, a cast shall be used to select the correct function.

An expected result data type exists in any of the following contexts:

- Right-hand side of an assignment or assignment expression
- Actual input argument of a subroutine call
- Input port connection of a module, interface, or program
- Actual parameter to a module, interface, program, or class
- Relational operator with unambiguous comparison
- Inside a cast

For example, suppose there is a structure type float:

```
typedef struct {
    bit sign;
    bit [3:0] exponent;
    bit [10:0] mantissa;
} float;
```

The + operator can be applied to this structure by invoking a function as indicated in the overloading declarations below:

```
bind + function float faddif(int, float);
bind + function float faddfi(float, int);
bind + function float faddrf(real, float);
bind + function float faddrf(shortreal, float);
bind + function float faddfr(float, real);
bind + function float faddfr(float, shortreal);
bind + function float faddff(float, float);
bind + function float fcopyf(float); // unary +
bind + function float fcopyi(int); // unary +
bind + function float fcopyr(real); // unary +
bind + function float fcopyr(shortreal); // unary +

float A, B, C, D;
assign A = B + C; //equivalent to A = faddff(B, C);
assign D = A + 1.0; //equivalent to A = faddfr(A, 1.0);
```

The overloading declaration links the + operator to each function prototype according to the corresponding argument data types in the overloaded expression, which normally shall match exactly. The exception is if the actual argument is an integral type and there is only one prototype with a corresponding integral argument, in which case the normal implicit casting rules apply when calling the function. For example, the fcopyi function can be defined with an int argument:

```
function float fcopyi (int i);
    float o;
    o.sign = i[31];
    o.exponent = 0;
    o.mantissa = 0;
    ...
    return o;
endfunction
```

Overloading the assignment operator also serves to overload implicit assignments or casting. Here these are using the same functions as the unary +.

```
bind = function float fcopyi(int);           // cast int to float
bind = function float fcopyr(real);         // cast real to float
bind = function float fcopyr(shortreal);    // cast shortreal to float
```

The operators that can be overloaded are the arithmetic operators, the relational operators, and assignment. The assignment operator from a float to a float cannot be overloaded above because it is already legal in the three preceding **bind** statements. Similarly, equality and inequality between floats cannot be overloaded.

No format can be assumed for 0 or 1; therefore, the user cannot rely on subtraction to give equality or on addition to give increment. Similarly, no format can be assumed for positive or negative; therefore, comparison shall be explicitly coded.

An assignment operator such as += is automatically built from both the + and = operators successively, where the = has its normal meaning. For example:

```
float A, B;
bind + function float faddff(float, float);
always @(posedge clock) A += B;    // equivalent to A = A + B
```

The scope and visibility of the overload declaration follows the same search rules as a data declaration. The overload declaration shall be defined before use in a scope that is visible. The function bound by the overload declaration uses the same scope search rules as a function call from the scope where the operator is invoked.

11.12 Minimum, typical, and maximum delay expressions

SystemVerilog delay expressions can be specified as three expressions separated by colons and enclosed by parentheses. This is intended to represent minimum, typical, and maximum values—in that order. The syntax is given in [Syntax 11-8](#).

```
mintypmax_expression ::= //from A.8.3
  expression
  | expression : expression : expression
constant_mintypmax_expression ::=
  constant_expression
  | constant_expression : constant_expression : constant_expression
expression ::=
  primary
  | unary_operator { attribute_instance } primary
  | inc_or_dec_expression
  | ( operator_assignment )
  | expression binary_operator { attribute_instance } expression
  | conditional_expression
  | inside_expression
  | tagged_union_expression
constant_expression ::=
  constant_primary
  | unary_operator { attribute_instance } constant_primary
  | constant_expression binary_operator { attribute_instance } constant_expression
```

```

    | constant_expression ? { attribute_instance } constant_expression : constant_expression
constant_primary ::= //from A.8.4
    primary_literal
    | ps_parameter_identifier constant_select
    | specparam_identifier [ [ constant_range_expression ] ]
    | genvar_identifier35
    | [ package_scope | class_scope ] enum_identifier
    | constant_concatenation
    | constant_multiple_concatenation
    | constant_function_call
    | ( constant_mintypmax_expression )
    | constant_cast
    | constant_assignment_pattern_expression
    | type_reference36
primary_literal ::= number | time_literal | unbased_unsized_literal | string_literal

```

³⁶⁾ It shall be legal to use a type_reference constant_primary as the casting_type in a static cast. It shall be illegal for a type_reference constant_primary to be used with any operators except the equality/inequality and case equality/inequality operators.

³⁵⁾ A genvar_identifier shall be legal in a constant_primary only within a genvar_expression.

Syntax 11-8—Syntax for min:typ:max expression (excerpt from [Annex A](#))

SystemVerilog models typically specify three values for delay expressions. The three values allow a design to be tested with minimum, typical, or maximum delay values, known as a *min:typ:max expression*.

Values expressed in min:typ:max format can be used in expressions. The min:typ:max format can be used wherever expressions can appear.

Example 1—This example shows an expression that defines a single triplet of delay values. The minimum value is the sum of a+d; the typical value is b+e; the maximum value is c+f, as follows:

```
(a:b:c) + (d:e:f)
```

Example 2—The next example shows a typical expression that is used to specify min:typ:max format values:

```
val = (32'd 50: 32'd 75: 32'd 100)
```

11.13 Let construct

```

assertion_item_declaration ::= //from A.2.10
    ...
    | let_declaration
let_declaration ::=
    let let_identifier [ ( [ let_port_list ] ) ] = expression ;
let_identifier ::=
    identifier
let_port_list ::=

```

```

    let_port_item { , let_port_item }
let_port_item ::=
    { attribute_instance } let_formal_type port_identifier { variable_dimension } [ = expression ]
let_formal_type ::=
    data_type_or_implicit
let_expression ::=
    [ package_scope ] let_identifier [ ( [ let_list_of_arguments ] ) ]
let_list_of_arguments ::=
    [ let_actual_arg ] { , [ let_actual_arg ] } { , . identifier ( [ let_actual_arg ] ) }
    | . identifier ( [ let_actual_arg ] ) { , . identifier ( [ let_actual_arg ] ) }
let_actual_arg ::=
    expression
primary ::=
    ...
    | let_expression
    ...

```

//from [A.8.4](#)

Syntax 11-9—Let syntax (excerpt from [Annex A](#))

A **let** declaration defines a template expression (a **let** body), customized by its ports. A **let** construct may be instantiated in other expressions.

let declarations can be used for customization and can replace the text macros in many cases. The **let** construct is safer because it has a local scope, while the scope of compiler directives is global within the compilation unit. Including **let** declarations in packages (see [Clause 26](#)) is a natural way to implement a well-structured customization for the design code.

Example 1

```

package pex_gen9_common_expressions;
    let valid_arb(request, valid, override) = |(request & valid) || override;
    ...
endpackage

module my_checker;
    import pex_gen9_common_expressions::*;
    logic a, b;
    wire [1:0] req;
    wire [1:0] vld;
    logic ovr;
    ...
        if (valid_arb(.request(req), .valid(vld), .override(ovr))) begin
            ...
        end
    ...
endmodule

```

Example 2

```

let mult(x, y) = ($bits(x) + $bits(y))'(x * y);

```

Just as properties and sequences serve as templates for concurrent assertions (see [16.5](#)), the **let** construct can serve this purpose for immediate assertions. For example:

```
let at_least_two(sig, rst = 1'b0) = rst || ($countones(sig) >= 2);  
logic [15:0] sig1;  
logic [3:0] sig2;  
  
always_comb begin  
    q1: assert (at_least_two(sig1));  
    q2: assert (at_least_two(~sig2));  
end
```

Another intended use of **let** is to provide shortcuts for identifiers or subexpressions. For example:

```
task write_value;  
    input logic [31:0] addr;  
    input logic [31:0] value;  
    ...  
endtask  
...  
let addr = top.block1.unit1.base + top.block1.unit2.displ;  
...  
write_value(addr, 0);
```

The formal arguments may optionally be typed and also may have optional default values. If a formal argument of a **let** is typed then the type shall be event or one of the types allowed in [16.6.1](#). The following rules apply to typed formal arguments and their corresponding actual arguments, including default actual arguments declared in a **let**:

- 1) If the formal argument is of type event, then the actual argument shall be an *event_expression* and each reference to the formal argument shall be in a place where an *event_expression* may be written.
- 2) Otherwise, the self-determined result type of the actual argument shall be cast compatible (see [6.22.4](#)) with the type of the formal argument. The actual argument shall be cast to the type of the formal argument before being substituted for a reference to the formal argument in the rewriting algorithm (see [F.4.1](#)).

Variables used in a **let** that are not formal arguments to the **let** are resolved according to the scoping rules from the scope in which the **let** is declared. In the scope of declaration, a **let** body shall be defined before it is used. No hierarchical references to **let** declarations are allowed.

The **let** body gets expanded with the actual arguments by replacing the formal arguments with the actual arguments. Semantic checks are performed to verify that the expanded **let** body with the actual arguments is legal. The result of the substitution is enclosed in parentheses (...) so as to preserve the priority of evaluation of the **let** body. Recursive **let** instantiations are not permitted.

A **let** body may contain sampled value function calls (see [16.9.3](#) and [16.9.4](#)). Their clock, if not explicitly specified, is inferred in the instantiation context in the same way as if the functions were used directly in the instantiation context. It shall be an error if the clock is required, but cannot be inferred in the instantiation context.

A **let** may be declared in any of the following:

- A module
- An interface
- A program
- A checker
- A clocking block

- A package
- A compilation-unit scope
- A generate block
- A sequential or parallel block
- A subroutine

Examples:

- a) **let** with arguments and without arguments.

```

module m;
  logic clk, a, b;
  logic p, q, r;

  // let with formal arguments and default value on y
  let eq(x, y = b) = x == y;

  // without parameters, binds to a, b above
  let tmp = a && b;
  ...
  a1: assert property (@(posedge clk) eq(p,q));
  always_comb begin
    a2: assert (eq(r)); // use default for y
    a3: assert (tmp);
  end
endmodule : m

```

The effective code after expanding **let** expressions:

```

module m;
  bit clk, a, b;
  logic p, q, r;
  // let eq(x, y = b) = x == y;
  // let tmp = a && b;
  ...
  a1: assert property (@(posedge clk) (m.p == m.q));
  always_comb begin
    a2: assert ((m.r == m.b)); // use default for y
    a3: assert ((m.a && m.b));
  end
endmodule : m

```

- b) Declarative context binding of **let** arguments

```

module top;
  logic x = 1'b1;
  logic a, b;
  let y = x;
  ...
  always_comb begin
    // y binds to preceding definition of x
    // in the declarative context of let
    bit x = 1'b0;
    b = a | y;
  end
endmodule : top

```

The effective code after expanding **let** expressions:

```

module top;
  bit x = 1'b1;

```



```

    bit a;
    // let y = x;
    ...
    always_comb begin
        // y binds to preceding definition of x
        // in the declarative context of let
        bit x = 1'b0;
        b = a | (top.x);
    end
endmodule : top

```

c) Sequences (and properties) with **let** in structural context (see [16.8](#)):

```

module top;
    logic a, b;
    let x = a || b;
    sequence s;
        x ##1 b;
    endsequence : s
    ...
endmodule : top

```

The effective code after expanding **let** expressions:

```

module top;
    logic a, b;
    // let x = a || b;
    sequence s;
        (top.a || top.b) ##1 b;
    endsequence : s
    ...
endmodule : top

```

d) **let** declared in a **generate** block

```

module m(...);
    wire a, b;
    wire [2:0] c;
    wire [2:0] d;
    wire e;
    ...
    for (genvar i = 0; i < 3; i++) begin : L0
        if (i != 1) begin : L1
            let my_let(x) = !x || b && c[i];
            s1: assign d[2 - i] = my_let(a); // OK
        end : L1
    end : L0
    s2: assign e = L0[0].L1.my_let(a); // Illegal
endmodule : m

```

Statement *s1* becomes two statements `L0[0].L1.s1` and `L0[2].L1.s1`, the first of them being

```
assign d[2] = (!m.a || m.b && m.c[0]);
```

and the second one being

```
assign d[0] = (!m.a || m.b && m.c[2]);
```

Statement *s2* is illegal since it references the **let** expression hierarchically, while hierarchical references to **let** expressions are not allowed.

e) **let** with typed arguments

```

module m(input clock);
  logic [15:0] a, b;
  logic c, d;
  typedef bit [15:0] bits;
  ...
  let ones_match(bits x, y) = x == y;
  let same(logic x, y) = x === y;

  always_comb
    a1: assert(ones_match(a, b));

  property toggles(bit x, y);
    same(x, y) |=> !same(x, y);
  endproperty

  a2: assert property (@(posedge clock) toggles(c, d));
endmodule : m

```

In this example the **let** expression `ones_match` checks that both arguments have bits set to 1 at the same position. Because of the explicit specification of the formal arguments to be of the 2-state type **bit** in the **let** declaration, all argument bits having unknown logic value or a high-impedance value become 0, and therefore the comparison captures the match of the bits set to 1. The **let** expression `same` tests for the case equality (see [11.4.6](#)) of its operands. When instantiated in the property `toggles` its actual arguments will be of type **bit**. The effective code after expanding **let** expressions:

```

module m(input clock);
  logic [15:0] a, b;
  logic c, d;
  typedef bit [15:0] bits;
  ...
  // let ones_match(bits x, y) = x == y;
  // let same(logic x, y) = x === y;

  always_comb
    a1:assert((bits'(a) == bits'(b)));

  property toggles(bit x, y);
    (logic'(x) === logic'(y)) |=> ! (logic'(x) === logic'(y));
  endproperty

  a2: assert property (@(posedge clock) toggles(c, d));
endmodule : m

```

f) Sampled value functions in **let**

```

module m(input clock);
  logic a;
  let p1(x) = $past(x);
  let p2(x) = $past(x,,@(posedge clock));
  let s(x) = $sampled(x);
  always_comb begin
    a1: assert(p1(a));
    a2: assert(p2(a));
    a3: assert(s(a));
  end
  a4: assert property(@(posedge clock) p1(a));
  ...
endmodule : m

```

The effective code after expanding **let** expressions:

```
module m(input clock);  
  logic a;  
  // let p1(x) = $past(x);  
  // let p2(x) = $past(x,,,@(posedge clock));  
  // let s(x) = $sampled(x);  
  always_comb begin  
    a1: assert($past(a)); // Illegal: no clock can be inferred  
    a2: assert($past(a,,,@(posedge clock)));  
    a3: assert($sampled (a));  
  end  
  a4: assert property(@(posedge clock) ($past(a))); // @(posedge clock)  
                                                // is inferred  
  ...  
endmodule : m
```

12. Procedural programming statements

12.1 General

This clause describes the following:

- Selection statements (if–else, case, casez, casex, unique, unique0, priority)
- Loop statements (for, repeat, foreach, while, do...while, forever)
- Jump statements (break, continue, return)

12.2 Overview

Procedural programming statements shall be contained within any of the following constructs:

- Procedural blocks that automatically activate, introduced with one of the keywords:
 - **initial**
 - **always**
 - **always_comb**
 - **always_latch**
 - **always_ff**
 - **final**

See [Clause 9](#) for a description of each type of procedural block.
- Procedural blocks that activate when called, introduced with one of the keywords:
 - **task**
 - **function**

See [Clause 13](#) for a description of tasks and functions.

Procedural programming statements include the following:

- Selection statements (see [12.4](#) and [12.5](#))
- Loop statements (see [12.7](#))
- Jump statements (see [12.8](#))
- Sequential and parallel blocks (see [9.3](#))
- Timing controls (see [9.4](#))
- Process control (see [9.5](#) through [9.7](#))
- Procedural assignments (see [10.4](#) through [10.9](#))
- Subroutine calls (see [Clause 13](#))

12.3 Syntax

The syntax for procedural statements is as follows in [Syntax 12-1](#):

```

statement_or_null ::=
    statement
    | { attribute_instance } ;
statement ::= [ block_identifier : ] { attribute_instance } statement_item
statement_item ::=
    blocking_assignment ;
    | nonblocking_assignment ;
    | procedural_continuous_assignment ;
  
```

// from [A.6.4](#)

```

| case_statement
| conditional_statement
| inc_or_dec_expression ;
| subroutine_call_statement
| disable_statement
| event_trigger
| loop_statement
| jump_statement
| par_block
| procedural_timing_control_statement
| seq_block
| wait_statement
| procedural_assertion_statement
| clocking_drive ;
| randsequence_statement
| randcase_statement
| expect_property_statement

```

Syntax 12-1—Procedural statement syntax (excerpt from [Annex A](#))

12.4 Conditional if–else statement

The *conditional statement* (or *if–else statement*) is used to make a decision about whether a statement is executed. Formally, the syntax is given in [Syntax 12-2](#).

```

conditional_statement ::= // from A.6.6
    [ unique_priority ] if ( cond_predicate ) statement_or_null
    { else if ( cond_predicate ) statement_or_null }
    [ else statement_or_null ]
unique_priority ::= unique | unique0 | priority
cond_predicate ::=
    expression_or_cond_pattern { &&& expression_or_cond_pattern }
expression_or_cond_pattern ::=
    expression | cond_pattern
cond_pattern ::= expression matches pattern

```

Syntax 12-2—Syntax for if–else statement (excerpt from [Annex A](#))

If the *cond_predicate* expression evaluates to true (that is, has a nonzero known value), the first statement shall be executed. If it evaluates to false (that is, has a zero value or the value is *x* or *z*), the first statement shall not execute. If there is an else statement and the *cond_predicate* expression is false, the else statement shall be executed.

Because the numeric value of the *if* expression is tested for being zero, certain shortcuts are possible. For example, the following two statements express the same logic:

```

if (expression)
if (expression != 0)

```

Because the **else** part of an if-else is optional, there can be confusion when an **else** is omitted from a nested **if** sequence. This is resolved by always associating the else with the closest previous if that lacks an else. In the example below, the else goes with the inner **if**, as shown by indentation.

```

if (index > 0)
  if (rega > regb)
    result = rega;
  else // else applies to preceding if
    result = regb;

```

If that association is not desired, a begin-end block statement shall be used to force the proper association, as in the following example:

```

if (index > 0)
  begin
    if (rega > regb)
      result = rega;
    end
  else result = regb;

```

12.4.1 if-else-if construct

The if-else construct can be chained.

```

if (expression)      statement;
else if (expression) statement;
else if (expression) statement;
else                 statement;

```

This sequence of if-else statements (known as an *if-else-if* construct) is the most general way of writing a multiway decision. The expressions shall be evaluated in order. If any expression is true, the statement associated with it shall be executed, and this shall terminate the whole chain. Each statement is either a single statement or a block of statements.

The last else of the if-else-if construct handles the none-of-the-above or default case where none of the other conditions were satisfied. Sometimes there is no explicit action for the default. In that case, the trailing else statement can be omitted, or it can be used for error checking to catch an unexpected condition.

The following module fragment uses the if-else statement to test the variable `index` to decide whether one of three `modify_segn` variables has to be added to the memory address and which increment is to be added to the `index` variable.

```

// declare variables and parameters
logic [31:0]  instruction,
           segment_area[255:0];
logic [7:0]  index;
logic [5:0]  modify_seg1,
           modify_seg2,
           modify_seg3;

parameter
  segment1 = 0,  inc_seg1 = 1,
  segment2 = 20, inc_seg2 = 2,
  segment3 = 64, inc_seg3 = 4,
  data = 128;

// test the index variable
if (index < segment2) begin

```

```

    instruction = segment_area [index + modify_seg1];
    index = index + inc_seg1;
  end
  else if (index < segment3) begin
    instruction = segment_area [index + modify_seg2];
    index = index + inc_seg2;
  end
  else if (index < data) begin
    instruction = segment_area [index + modify_seg3];
    index = index + inc_seg3;
  end
  else
    instruction = segment_area [index];
  end

```

12.4.2 unique-if, unique0-if, and priority-if

The keywords **unique**, **unique0**, and **priority** can be used before an **if** to perform certain *violation checks*.

If the keywords **unique** or **priority** are used, a *violation report* shall be issued if no condition matches unless there is an explicit **else**. For example:

```

unique if ((a==0) || (a==1)) $display("0 or 1");
else if (a == 2) $display("2");
else if (a == 4) $display("4"); // values 3,5,6,7 cause a violation report

priority if (a[2:1]==0) $display("0 or 1");
else if (a[2] == 0) $display("2 or 3");
else $display("4 to 7"); // covers all other possible values,
                        // so no violation report

```

If the keyword **unique0** is used, there shall be no violation if no condition is matched. For example:

```

unique0 if ((a==0) || (a==1)) $display("0 or 1");
else if (a == 2) $display("2");
else if (a == 4) $display("4"); // values 3,5,6,7
                        // cause no violation report

```

Unique-if and *unique0-if* assert that there is no overlap in a series of if-else-if conditions, i.e., they are mutually exclusive and hence it is safe for the conditions to be evaluated in parallel.

In *unique-if* and *unique0-if*, the conditions may be evaluated and compared in any order. The implementation shall continue the evaluations and comparisons after finding a true condition. A *unique-if* or *unique0-if* is *violated* if more than one condition is found true. The implementation shall issue a violation report and execute the statement associated with the true condition that appears first in the **if** statement, but not the statements associated with other true conditions.

After finding a uniqueness violation, the implementation is not required to continue evaluating and comparing additional conditions. The implementation is not required to try more than one order of evaluations and comparisons of conditions. The presence of side-effects in conditions may cause non-deterministic results.

A *priority-if* indicates that a series of if-else-if conditions shall be evaluated in the order listed. In the preceding example, if the variable *a* had a value of 0, it would satisfy both the first and second conditions, requiring priority logic.

The **unique**, **unique0**, and **priority** keywords apply to the entire series of if–else–if conditions. In the preceding examples, it would have been illegal to insert any of these keywords after any of the occurrences of **else**. To nest another **if** statement within such a series of conditions, a begin–end block should be used.

12.4.2.1 Violation reports generated by unique-if, unique0-if, and priority-if constructs

The descriptions in [12.4.2](#) mention several cases in which a violation report shall be generated by unique-if, unique0-if, or priority-if statements. These violation checks shall be immune to false violation reports due to zero-delay glitches in the active region set (see [4.4.1](#)).

A unique, unique0, or priority violation check is evaluated at the time the statement is executed, but violation reporting is deferred until the Observed region of the current time step (see [4.4](#)).

Once a violation is detected, a *pending violation report* is scheduled in the Observed region of the current time step. It is scheduled on a *violation report queue* associated with the currently executing process. A *violation report flush point* is said to be reached if any of the following conditions are met:

- The procedure, having been suspended earlier due to reaching an event control or wait statement, resumes execution.
- The procedure was declared by an **always_comb** or **always_latch** statement, and its execution is resumed due to a transition on one of its dependent signals.

If a violation report flush point is reached in a process, its violation report queue is cleared. Any pending violation reports are discarded.

In the Observed region of each simulation time step, each pending violation report shall mature, or be confirmed for reporting. Once a report matures, it shall no longer be flushed. A tool-specific violation report mechanism is then used to report each violation, and the pending violation report is cleared from the appropriate process violation report queue.

The following is an example of a unique-if that is immune to zero-delay glitches in the active region set:

```
always_comb begin
    not_a = !a;
end

always_comb begin : a1
    u1: unique if (a)
        z = a | b;
    else if (not_a)
        z = a | c;
end
```

In this example, **unique if** u1 is checking for overlap in the two conditional expressions. When a and not_a are in a state of 0 and 1 respectively and a transitions to 1, this **unique if** could be executed while a and not_a are both true, so the violation check for uniqueness will fail. Since this check is in the active region set, the failure is not immediately reported. After the update to not_a, process a1 will be rescheduled, which results in a flush of the original violation report. The violation check will now pass, and no violation will be reported.

Another example shows how looping constructs are likewise immune to zero-delay glitches in the active region set:

```
always_comb begin
```



```

    for (int j = 0; j < 3; j++)
        not_a[j] = !a[j];
end

always_comb begin : a1
    for (int j = 0; j < 3; j++)
        unique if (a[j])
            z[j] = a[j] | b[j];
        else if (not_a[j])
            z[j] = a[j] | c[j];
    end
end

```

This example is identical to the previous example but adds loop statements. Each loop iteration independently checks for a uniqueness violation in the exact same manner as the previous example. Any iteration in the loop can report a uniqueness violation. If the process `a1` is rescheduled, all violations in the loop are flushed and the entire loop is reevaluated.

12.4.2.2 If statement violation reports and multiple processes

As described in the above subclauses (see [12.4.2](#) and [12.4.2.1](#)), violation reports are inherently associated with the process in which they are executed. This means that a violation check within a task or function may be executed several times due to the task or function being called by several different processes, and each of these different process executions is independent. The following example illustrates this situation:

```

module fsm(...);
    function bit f1(bit a, bit not_a, ...)
        ...
        a1: unique if (a)
            ...
        else if (not_a)
            ...
        endfunction
    ...
    always_comb begin : b1
        some_stuff = f1(c, d, ...);
        ...
    end

    always_comb begin : b2
        other_stuff = f1(e, f, ...);
        ...
    end
endmodule

```

In this case, there are two different processes which may call process `a1`: `b1` and `b2`. Suppose simulation executes the following scenario in the first passage through the Active region of each time step. Note that this example refers to three distinct points in simulation time and how glitch resolution is handled for each specific time step:

- a) In time step 1, `b1` executes with `c=1` and `d=1`, and `b2` executes with `e=1` and `f=1`.

In this first time step, since `a1` fails independently for processes `b1` and `b2`, its failure is reported twice.

- b) In time step 2, `b1` executes with `c=1` and `d=1`, then again with `c=1` and `d=0`.

In this second time step, the failure of *a1* in process *b1* is flushed when the process is re-triggered, and since the final execution passes, no failure is reported.

- c) In time step 3, *b1* executes with *c*=1 and *d*=1, then *b2* executes with *e*=1 and *f*=0.

In this third time step, the failure in process *b1* does not see a flush point, so that failure is reported. In process *b2*, the violation check passes, so no failure is reported from that process.

12.5 Case statement

The *case* statement is a multiway decision statement that tests whether an expression matches one of a number of other expressions and branches accordingly. The case statement has the syntax shown in [Syntax 12-3](#).

```

case_statement ::=
    [ unique_priority ] case_keyword ( case_expression )
        case_item { case_item } endcase
    | [ unique_priority ] case_keyword (case_expression )matches
        case_pattern_item { case_pattern_item } endcase
    | [ unique_priority ] case ( case_expression ) inside
        case_inside_item { case_inside_item } endcase
case_keyword ::= case | casez | casex
case_expression ::= expression
case_item ::=
    case_item_expression { , case_item_expression } : statement_or_null
    | default [ : ] statement_or_null
case_pattern_item ::=
    pattern [ &&& expression ] : statement_or_null
    | default [ : ] statement_or_null
case_inside_item ::=
    open_range_list : statement_or_null
    | default [ : ] statement_or_null
case_item_expression ::= expression

```

Syntax 12-3—Syntax for case statements (excerpt from [Annex A](#))

The *default* statement shall be optional. Use of multiple default statements in one case statement shall be illegal.

The *case_expression* and *case_item_expressions* are not required to be constant expressions.

A simple example of the use of the case statement is the decoding of variable *data* to produce a value for *result* as follows:

```

logic [15:0] data;
logic [9:0] result;

case (data)
    16'd0: result = 10'b0111111111;
    16'd1: result = 10'b1011111111;

```

```

16'd2: result = 10'b1101111111;
16'd3: result = 10'b1110111111;
16'd4: result = 10'b1111011111;
16'd5: result = 10'b1111101111;
16'd6: result = 10'b1111110111;
16'd7: result = 10'b1111111011;
16'd8: result = 10'b1111111101;
16'd9: result = 10'b1111111110;
default result = 'x;
endcase

```

The *case_expression* shall be evaluated exactly once and before any of the *case_item_expressions*. The *case_item_expressions* shall be evaluated and then compared in the exact order in which they appear. If there is a default *case_item*, it is ignored during this linear search. During the linear search, if one of the *case_item_expressions* matches the *case_expression*, then the statement associated with that *case_item* shall be executed, and the linear search shall terminate. If all comparisons fail and the default item is given, then the default item statement shall be executed. If the default statement is not given and all of the comparisons fail, then none of the *case_item* statements shall be executed.

Apart from syntax, the case statement differs from the multiway if–else–if construct in two important ways:

- a) The conditional expressions in the if–else–if construct are more general than comparing one expression with several others, as in the case statement.
- b) The case statement provides a definitive result when there are *x* and *z* values in an expression.

In a *case_expression* comparison, the comparison only succeeds when each bit matches exactly with respect to the values 0, 1, *x*, and *z*. As a consequence, care is needed in specifying the expressions in the case statement. The bit length of all the expressions needs to be equal, so that exact bitwise matching can be performed. Therefore, the length of all the *case_item_expressions*, as well as the *case_expression*, shall be made equal to the length of the longest *case_expression* and *case_item_expressions*. If any of these expressions is unsigned, then all of them shall be treated as unsigned. If all of these expressions are signed, then they shall be treated as signed.

The reason for providing a *case_expression* comparison that handles the *x* and *z* values is that it provides a mechanism for detecting such values and reducing the pessimism that can be generated by their presence.

Example 1—The following example illustrates the use of a case statement to handle *x* and *z* values properly:

```

case (select[1:2])
  2'b00: result = 0;
  2'b01: result = flaga;
  2'b0x,
  2'b0z: result = flaga ? 'x : 0;
  2'b10: result = flagb;
  2'bx0,
  2'bz0: result = flagb ? 'x : 0;
  default result = 'x;
endcase

```

In this example, if *select[1]* is 0 and *flaga* is 0, then even if the value of *select[2]* is *x* or *z*, *result* should be 0—which is resolved by the third *case_item*.

Example 2—The following example shows another way to use a case statement to detect *x* and *z* values:

```

case (sig)

```

```

1'bz:    $display("signal is floating");
1'bx:    $display("signal is unknown");
default: $display("signal is %b", sig);
endcase

```

12.5.1 Case statement with do-not-cares

Two other types of case statements are provided to allow handling of do-not-care conditions in the case comparisons. One of these treats high-impedance values (z) as do-not-cares, and the other treats both high-impedance and unknown (x) values as do-not-cares. These case statements can be used in the same way as the traditional case statement, but they begin with keywords **casez** and **casex**, respectively.

Do-not-care values (z values for **casez**, z and x values for **casex**) in any bit of either the *case_expression* or the *case_items* shall be treated as do-not-care conditions during the comparison, and that bit position shall not be considered.

The syntax of literal numbers allows the use of the question mark (?) in place of z in these case statements. This provides a convenient format for specification of do-not-care bits in case statements.

Example 1—The following is an example of the casez statement. It demonstrates an instruction decode, where values of the most significant bits select which task should be called. If the most significant bit of *ir* is a 1, then the task *instruction1* is called, regardless of the values of the other bits of *ir*.

```

logic [7:0] ir;

casez (ir)
  8'b1??????: instruction1(ir);
  8'b01?????: instruction2(ir);
  8'b00010???: instruction3(ir);
  8'b000001???: instruction4(ir);
endcase

```

Example 2—The following is an example of the casex statement. It demonstrates an extreme case of how do-not-care conditions can be dynamically controlled during simulation. In this example, if $r = 8'b01100110$, then the task *stat2* is called.

```

logic [7:0] r, mask;

mask = 8'bx0x0x0x0;
casex (r ^ mask)
  8'b001100xx: stat1;
  8'b1100xx00: stat2;
  8'b00xx0011: stat3;
  8'bx010100: stat4;
endcase

```

12.5.2 Constant expression in case statement

A constant expression can be used for the *case_expression*. The value of the constant expression shall be compared against the *case_item_expressions*.

The following example demonstrates the usage by modeling a 3-bit priority encoder:

```

logic [2:0] encode ;

case (1)

```

```
    encode[2] : $display("Select Line 2") ;  
    encode[1] : $display("Select Line 1") ;  
    encode[0] : $display("Select Line 0") ;  
    default   $display("Error: One of the bits expected ON");  
endcase
```

In this example, the *case_expression* is a constant expression (1). The *case_items* are expressions (bit-selects) and are compared against the constant expression for a match.

12.5.3 unique-case, unique0-case, and priority-case

The **case**, **casez**, and **casex** keywords can be qualified by **priority**, **unique**, or **unique0** keywords to perform certain *violation checks*. These are collectively referred to as a *priority-case*, *unique-case* or *unique0-case*. A priority-case shall act on the first match only. Unique-case and unique0-case assert that there are no overlapping *case_items* and hence that it is safe for the *case_items* to be evaluated in parallel.

In unique-case and unique0-case, the *case_expression* shall be evaluated exactly once and before any of the *case_item_expressions*. The *case_item_expressions* may be evaluated in any order and compared in any order. The implementation shall continue the evaluations and comparisons after finding a matching *case_item*. Unique-case and unique0-case are *violated* if more than one *case_item* is found to match the *case_expression*. The implementation shall issue a violation report and execute the statement associated with the matching *case_item* that appears first in the case statement, but not the statements associated with other matching *case_items*.

After finding a uniqueness violation, the implementation is not required to continue evaluating and comparing additional *case_items*. It is not a violation of uniqueness for a single *case_item* to contain more than one *case_item_expression* that matches the *case_expression*. If a *case_item_expression* matches the *case_expression*, the implementation is not required to evaluate additional *case_item_expressions* in the same *case_item*. The implementation is not required to try more than one order of evaluations and comparisons of *case_item_expressions*. The presence of side-effects in *case_item_expressions* may cause non-deterministic results.

If the case is qualified as priority or unique, the simulator shall issue a violation report if no *case_item* matches. A violation report may be issued at compile time if it is possible then to determine the violation. If it is not possible to determine the violation at compile time, a violation report shall be issued during run time. If the case is qualified as **unique0**, the implementation shall not issue a violation report if no *case_item* matches.

NOTE—By specifying **unique** or **priority**, it is not necessary to code a **default** case to trap unexpected case values.

Consider the following example:

```
bit [2:0] a;  
unique case(a) // values 3,5,6,7 cause a violation report  
    0,1: $display("0 or 1");  
    2: $display("2");  
    4: $display("4");  
endcase  
  
priority casez(a) // values 4,5,6,7 cause a violation report  
    3'b00?: $display("0 or 1");  
    3'b0??: $display("2 or 3");  
endcase  
  
unique0 case(a) // values 3,5,6,7 do not cause a violation report
```

```

    0,1: $display("0 or 1");
    2: $display("2");
    4: $display("4");
endcase

```

12.5.3.1 Violation reports generated by unique-case, unique0-case, and priority-case constructs

The descriptions in [12.5.3](#) mention several cases in which a violation report shall be generated by unique-case, unique0-case, or priority-case statements. These violation checks shall be immune to false violation reports due to zero-delay glitches in the active region set (see [4.4.1](#)).

The mechanics of handling zero-delay glitches shall be identical to those used when processing zero-delay glitches for unique-if, unique0-if, and priority-if constructs (see [12.4.2.1](#)).

The following is an example of a unique-case that is immune to zero-delay glitches in the active region set:

```

always_comb begin
    not_a = !a;
end

always_comb begin : a1
    unique case (1'b1)
        a      : z = b;
        not_a  : z = c;
    endcase
end

```

In this example the **unique case** is checking for overlap in the two *case_item* selects. When *a* and *not_a* are in state 0 and 1 respectively and *a* transitions to 1, this **unique case** could be executed while *a* and *not_a* are both true, so the violation check for uniqueness will fail. But since this violation check is in the active region set, the failure is not reported immediately. After the update to *not_a*, process *a1* will be rescheduled, which results in a flush of the original violation report. The violation check will now pass, and no violation will be reported.

12.5.3.2 Case statement violation reports and multiple processes

Case violation reports shall behave in the same manner as *if* violation reports when dealing with multiple processes (see [12.4.2.2](#)).

12.5.4 Set membership case statement

The keyword **inside** can be used after the parenthesized expression to indicate a set membership (see [11.4.13](#)). In a *case-inside* statement, the *case_expression* shall be compared with each *case_item_expression* (*open_range_list*) using the set membership inside operator. The **inside** operator uses asymmetric wildcard matching (see [11.4.6](#)). Accordingly, the *case_expression* shall be the left operand, and each *case_item_expression* shall be the right operand. The *case_expression* and each *case_item_expression* in braces shall be evaluated in the order specified by a normal case, unique-case, or priority-case statement. A *case_item* shall be matched when the inside operation compares the *case_expression* to the *case_item_expressions* and returns 1'b1 and no match when the operation returns 1'b0 or 1'bx. If all comparisons do not match and the default item is given, the default item statement shall be executed.

For example:

```

logic [2:0] status;
always @(posedge clock)
  priority case (status) inside
    1, 3 : task1; // matches 'b001 and 'b011
    3'b0?0, [4:7]: task2; // matches 'b000 'b010 'b0x0 'b0z0
                        // 'b100 'b101 'b110 'b111
  endcase // priority case fails all other values including
           // 'b00x 'b01x 'bxxx

```

12.6 Pattern matching conditional statements

Pattern matching provides a visual and succinct notation to compare a value against structures, tagged unions, and constants and to access their members. Pattern matching can be used with case and if-else statements and with conditional expressions. Before describing pattern matching in those contexts, the general concepts are described first.

A pattern is a nesting of tagged union and structure expressions with identifiers, constant expressions (see [11.2.1](#)), and the wildcard pattern “.*” at the leaves. For tagged union patterns, the identifier following the **tagged** keyword is a union member name. For **void** members, the nested member pattern is omitted.

```

pattern ::= // from A.6.7.1
  . variable_identifier
  | .*
  | constant_expression
  | tagged member_identifier [ pattern ]
  | '{ pattern { , pattern } }'
  | '{ member_identifier : pattern { , member_identifier : pattern } }'

```

Syntax 12-4—Pattern syntax (excerpt from [Annex A](#))

A pattern always occurs in a context of known type because it is matched against an expression of known type. Recursively, its nested patterns also have known type. A constant expression pattern shall be of integral type. Thus a pattern can always be statically type-checked.

Each pattern introduces a new scope; the extent of this scope is described separately below for case statements, if-else statements, and conditional expressions. Each pattern identifier is implicitly declared as a new variable within the pattern’s scope, with the unique type that it shall have based on its position in the pattern. Pattern identifiers shall be unique in the pattern, i.e., the same identifier cannot be used in more than one position in a single pattern.

In pattern-matching, the value V of an expression is always matched against a pattern, and static type checking verifies that V and the pattern have the same type. The result of a pattern match is as follows:

- A 1-bit determined value: 0 (false, or fail) or 1 (true, or succeed). The result cannot be x or z even if the value and pattern contain such bits.
- If the match succeeds, the pattern identifiers are bound to the corresponding members from V , using ordinary procedural assignment.
- Each pattern is matched using the following simple recursive rule:
 - An identifier pattern always succeeds (matches any value), and the identifier is bound to that value (using ordinary procedural assignment).

- The wildcard pattern “.*” always succeeds.
- A constant expression pattern succeeds if V is equal to its value.
- A tagged union pattern succeeds if the value has the same tag and, recursively, if the nested pattern matches the member value of the tagged union.
- A structure pattern succeeds if, recursively, each of the nested member patterns matches the corresponding member values in V . In structure patterns with named members, the textual order of members does not matter, and members can be omitted. Omitted members are ignored.

Conceptually, if the value V is seen as a flattened vector of bits, the pattern specifies which bits to match, with what values they should be matched, and, if the match is successful, which bits to extract and bind to the pattern identifiers. Matching can be insensitive to x and z values, as described in the individual constructs below.

12.6.1 Pattern matching in case statements

In a pattern-matching case statement, the expression in parentheses is followed by the keyword `matches`, and the statement contains a series of *case pattern items*. The left-hand side of a case item, before the colon (`:`), consists of a *pattern* and, optionally, the operator `&&&` followed by a Boolean filter *expression*. The right-hand side of a case item is a statement. Each pattern introduces a new scope, in which its pattern identifiers are implicitly declared; this scope extends to the optional filter expression and the statement in the right-hand side of the same case item. Thus different case items can reuse pattern identifiers.

All the patterns are completely statically type-checked. The expression being tested in the pattern-matching case statement shall have a known type, which is the same as the type of the pattern in each case item.

The expression in parentheses in a pattern-matching case statement shall be evaluated exactly once. Its value V shall be matched against the left-hand sides of the case items, one at a time, in the exact order given, ignoring the default case item if any. During this linear search, if a case item is selected, its statement is executed and the linear search is terminated. If no case item is selected and a default case item is given, then its statement is executed. If no case item is selected and no default case item is given, no statement is executed.

For a case item to be selected, the value V shall match the pattern (and the pattern identifiers are assigned the corresponding member values in V), and then the Boolean filter expression shall evaluate to true (a determined value other than 0).

Example 1:

```
typedef union tagged {
    void Invalid;
    int Valid;
} VInt;
...
VInt v;
...
case (v) matches
    tagged Invalid : $display ("v is Invalid");
    tagged Valid .n : $display ("v is Valid with value %d", n);
endcase
```

In the case statement, if `v` currently has the `Invalid` tag, the first pattern is matched. Otherwise, it must have the `Valid` tag, and the second pattern is matched. The identifier `n` is bound to the value of the `Valid` member, and this value is displayed. It is impossible to access the integer member value (`n`) when the tag is `Invalid`.

Example 2:

```

typedef union tagged {
  struct {
    bit [4:0] reg1, reg2, regd;
  } Add;
  union tagged {
    bit [9:0] JmpU;
    struct {
      bit [1:0] cc;
      bit [9:0] addr;
    } JmpC;
  } Jmp;
} Instr;
...
Instr instr;
...
case (instr) matches
  tagged Add '{.r1, .r2, .rd} &&& (rd != 0) : rf[rd] = rf[r1] + rf[r2];
  tagged Jmp .j : case (j) matches
    tagged JmpU .a : pc = pc + a;
    tagged JmpC '{.c, .a}: if (rf[c]) pc = a;
  endcase
endcase

```

If *instr* holds an Add instruction, the first pattern is matched, and the identifiers *r1*, *r2*, and *rd* are bound to the three register fields in the nested structure value. The right-hand statement executes the instruction on the register file *rf*. It is impossible to access these register fields if the tag is Jmp. If *instr* holds a Jmp instruction, the second pattern is matched, and the identifier *j* is bound to the nested tagged union value. The inner case statement, in turn, matches this value against JmpU and JmpC patterns and so on.

Example 3—(same as previous example, but using wildcard and constant patterns to eliminate the *rd* = 0 case; in some processors, register 0 is a special “discard” register):

```

case (instr) matches
  tagged Add '{.*, .*, 0} : ; // no op
  tagged Add '{.r1, .r2, .rd} : rf[rd] = rf[r1] + rf[r2];
  tagged Jmp .j : case (j) matches
    tagged JmpU .a : pc = pc + a;
    tagged JmpC '{.c, .a} : if (rf[c]) pc = a;
  endcase
endcase

```

Example 4—(same as previous example except that the first inner case statement involves only structures and constants but no tagged unions):

```

case (instr) matches
  tagged Add s: case (s) matches
    '{.*, .*, 0} : ; // no op
    '{.r1, .r2, .rd} : rf[rd] = rf[r1] + rf[r2];
  endcase
  tagged Jmp .j: case (j) matches
    tagged JmpU .a : pc = pc + a;
    tagged JmpC '{.c, .a} : if (rf[c]) pc = a;
  endcase
endcase

```

Example 5—(same as previous example, but using nested tagged union patterns):

```

case (instr) matches
  tagged Add '{.r1, .r2, .rd} &&& (rd != 0) : rf[rd] = rf[r1] + rf[r2];
  tagged Jmp (tagged JmpU .a) : pc = pc + a;
  tagged Jmp (tagged JmpC '{.c, .a}) : if (rf[c]) pc = a;
endcase

```

Example 6—(same as previous example, with named structure components):

```

case (instr) matches
  tagged Add '{reg2:.r2,regd:.rd,reg1:.r1} &&& (rd != 0):
                                          rf[rd] = rf[r1] + rf[r2];
  tagged Jmp (tagged JmpU .a) : pc = pc + a;
  tagged Jmp (tagged JmpC '{addr:.a,cc:.c}) : if (rf[c]) pc = a;
endcase

```

The **casez** and **casex** keywords can be used instead of **case**, with the same semantics. In other words, during pattern matching, wherever 2 bits are compared (whether they are tag bits or members), the **casez** form ignores *z* bits, and the **casex** form ignores both *z* and *x* bits.

The **priority** and **unique** qualifiers can also be used. **priority** implies that some case item must be selected. **unique** implies that some case item must be selected and also implies that exactly one case item will be selected so that they can be evaluated in parallel.

12.6.2 Pattern matching in if statements

The predicate in an if-else statement can be a series of clauses separated with the **&&&** operator. Each clause is either an expression (used as a Boolean filter) or has the form: *expression matches pattern*. The clauses represent a sequential conjunction from left to right (i.e., if any clause fails, the remaining clauses are not evaluated) and all of them shall succeed for the predicate to be true. Boolean expression clauses are evaluated as usual. Each pattern introduces a new scope, in which its pattern identifiers are implicitly declared; this scope extends to the remaining clauses in the predicate and to the corresponding “true” arm of the if-else statement.

In each *e matches p* clause, *e* and *p* shall have the same known statically-known type. The value of *e* is matched against the pattern *p* as described above.

Even though the pattern matching clauses always return a defined 1-bit result, the overall result can be ambiguous because of the Boolean filter expressions in the predicate. The standard semantics of if-else statements holds, i.e., the first statement is executed if, and only if, the result is a determined value other than 0.

Example 1:

```

if (e matches (tagged Jmp (tagged JmpC '{cc:.c,addr:.a})))
  ... // c and a can be used here
else
  ...

```

Example 2—(same as previous example, illustrating a sequence of two pattern matches with identifiers bound in the first pattern used in the second pattern):

```

if (e matches (tagged Jmp .j) &&&
  j matches (tagged JmpC '{cc:.c,addr:.a}))
  ... // c and a can be used here

```

```

else
...

```

Example 3—(same as first example, but adding a Boolean expression to the sequence of clauses). The idea expressed is “if *e* is a conditional jump instruction and the condition register is not equal to zero ...”.

```

if (e matches (tagged Jump (tagged JumpC '{cc:.c,addr:.a}'))
    &&& (rf[c] != 0))
    ... // c and a can be used here
else
...

```

The **priority** and **unique** qualifiers can be used even if they use pattern matching.

12.6.3 Pattern matching in conditional expressions

A conditional expression ($e_1 ? e_2 : e_3$) can also use pattern matching, i.e., the predicate e_1 can be a sequence of expressions and “*expression matches pattern*” clauses separated with the **&&&** operator, just like the predicate of an if–else statement. The clauses represent a sequential conjunction from left to right, (i.e., if any clause fails, the remaining clauses are not evaluated) and all of them shall succeed for the predicate to be true. Boolean expression clauses are evaluated as usual. Each pattern introduces a new scope, in which its pattern identifiers are implicitly declared; this scope extends to the remaining clauses in the predicate and to the consequent expression e_2 .

As described in the previous subclass, e_1 can evaluate to true, false, or an ambiguous value. The semantics of the overall conditional expression is described in [11.4.11](#), based on these three possible outcomes for e_1 .

12.7 Loop statements

SystemVerilog provides six types of looping constructs, as shown in [Syntax 12-5](#).

```

loop_statement ::=
    forever statement_or_null
    | repeat ( expression ) statement_or_null
    | while ( expression ) statement_or_null
    | for ( for_initialization ; expression ; for_step )
      statement_or_null
    | do statement_or_null while ( expression ) ;
    | foreach ( ps_or_hierarchical_array_identifier [ loop_variables ] ) statement
for_initialization ::=
    list_of_variable_assignments
    | for_variable_declaration { , for_variable_declaration }
for_variable_declaration ::=
    data_type variable_identifier = expression { , variable_identifier = expression }
for_step ::= for_step_assignment { , for_step_assignment }
for_step_assignment ::=
    operator_assignment
    | inc_or_dec_expression
    | function_subroutine_call
loop_variables ::= [ index_variable_identifier ] { , [ index_variable_identifier ] }

```

Syntax 12-5—Loop statement syntax (excerpt from [Annex A](#))

12.7.1 The for-loop

The *for-loop* controls execution of its associated statement(s) by a three-step process, as follows:

- a) Executes one or more *for_initialization* assignments, which are normally used to initialize a variable that controls the number of times the loop is executed.
- b) Evaluates an *expression*. If the result is zero, the for-loop shall exit. If it is not zero, the for-loop shall execute its associated statement(s) and then perform step c). If the expression evaluates to an unknown or high-impedance value, it shall be treated as zero.
- c) Executes one or more *for_step* assignments, normally used to modify the value of the loop-control variable, then repeats step b).

The variables used to control a for-loop can be declared prior to the loop. If loops in two or more parallel processes use the same loop control variable, there is a potential of one loop modifying the variable while other loops are still using it.

The variables used to control a for-loop can also be declared within the loop, as part of the *for_initialization* assignments. This creates an implicit begin-end block around the loop, containing declarations of the loop variables with automatic lifetime. This block creates a new hierarchical scope, making the variables local to the loop scope. The block is unnamed by default, but can be named by adding a statement label (9.3.5) to the for-loop statement. Thus, other parallel loops cannot inadvertently affect the loop control variable. For example:

```

module m;

    initial begin
        for (int i = 0; i <= 255; i++)
            ...
    end

    initial begin
        loop2: for (int i = 15; i >= 0; i--)
            ...
    end
endmodule

```

This is equivalent to the following:

```

module m;
    initial begin
        begin
            automatic int i;
            for (i = 0; i <= 255; i++)
                ...
        end
    end

    initial begin
        begin : loop2
            automatic int i;
            for (i = 15; i >= 0; i--)
                ...
        end
    end
endmodule

```

Only for-loop statements containing variable declarations as part of the for-initialization assignments create implicit begin-end blocks around them.

The initial declaration or assignment statement can be one or more comma-separated statements. The step assignment can also be one or more comma-separated assignment statements, increment or decrement expressions, or function calls.

```

for ( int count = 0; count < 3; count++ )
    value = value + ((a[count]) * (count+1));

for ( int count = 0, done = 0, j = 0; j * count < 125; j++, count++)
    $display("Value j = %d\n", j );
  
```

In a for-loop initialization, either all or none of the control variables shall be locally declared. In the second loop of the example above, `count`, `done`, and `j` are all locally declared. The following would be illegal because it attempts to locally declare `y` whereas `x` was not locally declared:

```

for (x = 0, int y = 0; ...)
  ...
  
```

In a for-loop initialization that declares multiple local variables, the initialization expression of a local variable can use earlier local variables.

```

for (int i = 0, j = i+offset; i < N; i++,j++)
  ...
  
```

12.7.2 The repeat loop

The *repeat-loop* executes a statement a fixed number of times. If the expression evaluates to unknown or high impedance, it shall be treated as zero, and no statement shall be executed.

In the following example of a repeat-loop, add and shift operators implement a multiplier:

```

parameter size = 8, longsize = 16;
logic [size:1] opa, opb;
logic [longsize:1] result;

begin : mult
  logic [longsize:1] shift_opa, shift_opb;
  shift_opa = opa;
  shift_opb = opb;
  result = 0;
  repeat (size) begin
    if (shift_opb[1])
      result = result + shift_opa;
      shift_opa = shift_opa << 1;
      shift_opb = shift_opb >> 1;
  end
end
  
```

12.7.3 The foreach loop

The *foreach-loop* construct specifies iteration over the elements of an array. Its argument is an identifier that designates any type of array followed by a comma-separated list of loop variables enclosed in square brackets. Each loop variable corresponds to one of the dimensions of the array. The foreach-loop is similar to a repeat-loop that uses the array bounds to specify the repeat count instead of an expression.

Examples:

```

string words [2] = '{ "hello", "world" };
int prod [1:8] [1:3];

foreach( words [ j ] )
    $display( j , words[j] );    // print each index and value

foreach( prod[ k, m ] )
    prod[k][m] = k * m;         // initialize

```

The number of loop variables shall not be greater than the number of dimensions of the array variable. Loop variables may be omitted to indicate no iteration over that dimension of the array, and trailing commas in the list may also be omitted. As in a for-loop (12.7.1), a foreach-loop creates an implicit begin-end block around the loop statement, containing declarations of the loop variables with automatic lifetime. This block creates a new hierarchical scope, making the variables local to the loop scope. The block is unnamed by default, but can be named by adding a statement label (9.3.5) to the foreach statement. foreach-loop variables are read-only. The type of each loop variable is implicitly declared to be consistent with the type of array index. It shall be an error for any loop variable to have the same identifier as the array.

The mapping of loop variables to array indices is determined by the dimension cardinality, as described in 20.7. The foreach-loop arranges for higher cardinality indices to change more rapidly.

```

//      1  2  3          3  4          1  2  -> Dimension numbers
int A [2][3][4];    bit [3:0][2:1] B [5:1][4];

foreach( A [ i, j, k ] ) ...
foreach( B [ q, r, , s ] ) ...

```

The first foreach-loop causes *i* to iterate from 0 to 1, *j* from 0 to 2, and *k* from 0 to 3. The second foreach-loop causes *q* to iterate from 5 to 1, *r* from 0 to 3, and *s* from 2 to 1 (iteration over the third index is skipped).

If the dimensions of a dynamically sized array are changed while iterating over a foreach-loop construct, the results are undefined and may cause invalid index values to be generated.

Multiple loop variables correspond to nested loops that iterate over the given indices. The nesting of the loops is determined by the dimension cardinality; outer loops correspond to lower cardinality indices. In the first example above, the outermost loop iterates over *i*, and the innermost loop iterates over *k*.

When loop variables are used in expressions other than as indices to the designated array, they are auto-cast into a type consistent with the type of index. For fixed-size and dynamic arrays, the auto-cast type is `int`. For associative arrays indexed by a specific index type, the auto-cast type is the same as the index type. To use different types, an explicit cast can be used.

12.7.4 The while loop

The *while-loop* executes a statement until an expression becomes false. If the expression starts out false, the statement shall not be executed at all.

The following example counts the number of logic 1 values in data:

```

begin : count1s
    logic [7:0] tempreg;
    count = 0;

```

```

tempreg = data;
while (tempreg) begin
    if (tempreg[0])
        count++;
    tempreg >>= 1;
end
end

```

12.7.5 The do...while loop

The *do...while-loop* differs from the while-loop in that a do...while-loop tests its control expression at the end of the loop. Loops with a test at the end are sometimes useful to save duplication of the loop body.

```

string s;
if ( map.first( s ) )
    do
        $display( "%s : %d\n", s, map[ s ] );
    while ( map.next( s ) );

```

The condition can be any expression that can be treated as a Boolean. It is evaluated after the statement.

12.7.6 The forever loop

The *forever-loop* continuously executes a statement. To avoid a zero-delay infinite loop, which could hang the simulation event scheduler, the forever loop should only be used in conjunction with the timing controls or the disable statement. For example:

```

initial begin
    clock1 <= 0;
    clock2 <= 0;
    fork
        forever #10 clock1 = ~clock1;
        #5 forever #10 clock2 = ~clock2;
    join
end

```

12.8 Jump statements

```

jump_statement ::=
    return [ expression ] ;
| break ;
| continue ;

```

//from [A.6.5](#)

Syntax 12-6—Jump statement syntax (excerpt from [Annex A](#))

SystemVerilog provides the C-like jump statements **break**, **continue**, and **return**.

```

break           // break out of loop, as in C
continue       // skip to end of loop, as in C
return expression // exit from a function
return         // exit from a task or void function

```

The **continue** and **break** statements can only be used in a loop. The **continue** statement jumps to the end of the loop and executes the loop control if present. The **break** statement jumps out of the loop.

The **continue** and **break** statements cannot be used inside a fork-join block to control a loop outside the fork-join block.

The **return** statement can only be used in a subroutine. In a function returning a value, the return statement shall have an expression of the correct type.

NOTE—SystemVerilog does not include the C **goto** statement.

13. Tasks and functions (subroutines)

13.1 General

This clause describes the following:

- Task declarations
- Function declarations
- Calling tasks and functions

13.2 Overview

Tasks and functions provide the ability to execute common procedures from several different places in a description. They also provide a means of breaking up large procedures into smaller ones to make it easier to read and debug the source descriptions. This clause discusses the differences between tasks and functions, describes how to define and invoke tasks and functions, and presents examples of each.

Tasks and functions are collectively referred to as *subroutines*.

The following rules distinguish tasks from functions, with exceptions noted in [13.4.4](#):

- The statements in the body of a function shall execute in one simulation time unit; a task may contain time-controlling statements.
- A function cannot enable a task; a task can enable other tasks and functions.
- A nonvoid function shall return a single value; a task or void function shall not return a value.
- A nonvoid function can be used as an operand in an expression; the value of that operand is the value returned by the function.

For example:

Either a task or a function can be defined to switch bytes in a 16-bit word. The task would return the switched word in an output argument; therefore, the source code to enable a task called `switch_bytes` could look like the following example:

```
switch_bytes (old_word, new_word);
```

The task `switch_bytes` would take the bytes in `old_word`, reverse their order, and place the reversed bytes in `new_word`.

A word-switching function would return the switched word as the return value of the function. Thus, the function call for the function `switch_bytes` could look like the following example:

```
new_word = switch_bytes (old_word);
```

13.3 Tasks

A task shall be enabled from a statement that defines the argument values to be passed to the task and the variables that receive the results. Control shall be passed back to the enabling process after the task has completed. Thus, if a task has timing controls inside it, then the time of enabling a task can be different from the time at which the control is returned. A task can enable other tasks, which in turn can enable still other tasks—with no limit on the number of tasks enabled. Regardless of how many tasks have been enabled, control shall not return until all enabled tasks have completed.

The syntax for task declarations is as follows in [Syntax 13-1](#).

```

task_declaration ::= task [ lifetime ] task_body_declaration //from A.2.7
task_body_declaration ::=
    [ interface_identifier . | class_scope ] task_identifier ;
    { tf_item_declaration }
    { statement_or_null }
    endtask [ : task_identifier ]
    | [ interface_identifier . | class_scope ] task_identifier ( [ tf_port_list ] ) ;
    { block_item_declaration }
    { statement_or_null }
    endtask [ : task_identifier ]
tf_item_declaration ::=
    block_item_declaration
    | tf_port_declaration
tf_port_list ::=
    tf_port_item { , tf_port_item }
tf_port_item23 ::=
    { attribute_instance }
    [ tf_port_direction ] [ var ] data_type_or_implicit
    [ port_identifier { variable_dimension } [ = expression ] ]
tf_port_direction ::= port_direction | const ref
tf_port_declaration ::=
    { attribute_instance } tf_port_direction [ var ] data_type_or_implicit list_of_tf_variable_identifiers ;
lifetime ::= static | automatic //from A.2.1
signing ::= signed | unsigned //from A.2.2.1
data_type_or_implicit ::=
    data_type
    | implicit_data_type
implicit_data_type ::= [ signing ] { packed_dimension }

```

²³⁾ In a `tf_port_item`, it shall be illegal to omit the explicit `port_identifier` except within a function prototype or task prototype.

Syntax 13-1—Task syntax (excerpt from [Annex A](#))

A task declaration has the formal arguments either in parentheses (like ANSI C) or in declarations and directions.

```

task mytask1 (output int x, input logic y);
    ...
endtask

task mytask2;
    output x;
    input y;
    int x;
    logic y;
    ...
endtask

```

Each formal argument has one of the following directions:

```

input           // copy value in at beginning
output          // copy value out at end
inout          // copy in at beginning and out at end
ref            // pass reference (see 13.5.2)

```

There is a default direction of **input** if no direction has been specified. Once a direction is given, subsequent formals default to the same direction. In the following example, the formal arguments *a* and *b* default to inputs, and *u* and *v* are both outputs:

```

task mytask3(a, b, output logic [15:0] u, v);
  ...
endtask

```

Each formal argument has a data type that can be explicitly declared or inherited from the previous argument. If the data type is not explicitly declared, then the default data type is **logic** if it is the first argument or if the argument direction is explicitly specified. Otherwise, the data type is inherited from the previous argument.

An array can be specified as a formal argument to a task. For example:

```

// the resultant declaration of b is input [3:0][7:0] b[3:0]
task mytask4(input [3:0][7:0] a, b[3:0], output [3:0][7:0] y[1:0]);
  ...
endtask

```

Multiple statements can be written between the task declaration and **endtask**. Statements are executed sequentially, the same as if they were enclosed in a **begin ... end** group. It shall also be legal to have no statements at all.

A task exits when the **endtask** is reached. The **return** statement can be used to exit the task before the **endtask** keyword.

A call to a task is also referred to as a *task enable* (see [13.5](#) for more details on calling tasks).

Example 1—The following example illustrates the basic structure of a task definition with five arguments:

```

task my_task;
  input a, b;
  inout c;
  output d, e;
  . . .           // statements that perform the work of the task
  . . .
  c = a;          // the assignments that initialize result outputs
  d = b;
  e = c;
endtask

```

Or using the second form of a task declaration, the task could be defined as follows:

```

task my_task (input a, b, inout c, output d, e);
  . . .           // statements that perform the work of the task
  . . .
  c = a;          // the assignments that initialize result variables
  d = b;

```

```
e = c;
endtask
```

The following statement calls the task:

```
initial
  my_task (v, w, x, y, z);
```

The task call arguments (v, w, x, y, and z) correspond to the arguments (a, b, c, d, and e) defined by the task. At the time of the call, the input and inout type arguments (a, b, and c) receive the values passed in v, w, and x. Thus, execution of the call effectively causes the following assignments:

```
a = v;
b = w;
c = x;
```

As part of the processing of the task, the task definition for `my_task` places the computed result values into c, d, and e. When the task completes, the following assignments to return the computed values to the calling process are performed:

```
x = c;
y = d;
z = e;
```

Example 2—The following example illustrates the use of tasks by describing a traffic light sequencer:

```
module traffic_lights;
  logic clock, red, amber, green;
  parameter on = 1, off = 0, red_tics = 350,
             amber_tics = 30, green_tics = 200;

  // initialize colors
  initial red = off;
  initial amber = off;
  initial green = off;

  always begin                                // sequence to control the lights
    red = on;                                  // turn red light on
    light(red, red_tics);                       // and wait.
    green = on;                                 // turn green light on
    light(green, green_tics);                   // and wait.
    amber = on;                                 // turn amber light on
    light(amber, amber_tics);                   // and wait.
  end

  // task to wait for 'tics' positive edge clocks
  // before turning 'color' light off
  task light (output color, input [31:0] tics);
    repeat (tics) @ (posedge clock);
    color = off;                                // turn light off.
  endtask: light

  always begin                                // waveform for the clock
    #100 clock = 0;
    #100 clock = 1;
  end
endmodule: traffic_lights
```

13.3.1 Static and automatic tasks

Tasks defined within a module, interface, program, or package default to being static, with all declared items being statically allocated. These items shall be shared across all uses of the task executing concurrently.

Tasks can be defined to use automatic storage in the following two ways:

- Explicitly declared using the optional `automatic` keyword as part of the task declaration.
- Implicitly declared by defining the task within a module, interface, program, or package that is defined as `automatic`.

Tasks defined within a class default to being automatic. Tasks can be defined to use static storage by explicitly defining the task as `static`.

All items declared inside automatic tasks are allocated dynamically for each invocation. All formal arguments and local variables are stored on the stack.

Automatic task items cannot be accessed by hierarchical references. Automatic tasks can be invoked through use of their hierarchical name.

Specific local variables can be declared as `automatic` within a static task or as `static` within an automatic task.

13.3.2 Task memory usage and concurrent activation

A task may be enabled more than once concurrently. All variables of an automatic task shall be replicated on each concurrent task invocation to store state specific to that invocation. All variables of a static task shall be static in that there shall be a single variable corresponding to each declared local variable in a module instance, regardless of the number of concurrent activations of the task. However, static tasks in different instances of a module shall have separate storage from each other.

Variables declared in static tasks, including `input`, `output`, and `inout` type arguments, shall retain their values between invocations. They shall be initialized to the default initialization value as described in [6.8](#).

Variables declared in automatic tasks, including `output` type arguments, shall be initialized to the default initialization value whenever execution enters their scope. `input` and `inout` type arguments shall be initialized to the values passed from the expressions corresponding to these arguments listed in the task-enabling statements.

Because variables declared in automatic tasks are deallocated at the end of the task invocation, they shall not be used in certain constructs that might refer to them after that point:

- They shall not be assigned values using nonblocking assignments or procedural continuous assignments.
- They shall not be referenced by procedural continuous assignments or procedural force statements.
- They shall not be referenced in intra-assignment event controls of nonblocking assignments.
- They shall not be traced with system tasks such as `$monitor` and `$dumpvars`.

13.4 Functions

The primary purpose of a function is to return a value that is to be used in an expression. A void function can also be used instead of a task to define a subroutine that executes and returns within a single time step. The rest of this clause explains how to define and use functions.

Functions have restrictions that make certain they return without suspending the process that enable them. The following rules shall govern their usage, with exceptions noted in [13.4.4](#):

- a) A function shall not contain any time-controlled statements. That is, any statements containing #, ##, @, **fork**, **wait**, **wait_order**, or **expect**.
- b) A function shall not enable tasks regardless of whether those tasks contain time-controlling statements.
- c) Functions may enable fine-grain process control methods to suspend its own or another process (see [9.7](#)).

The syntax for defining a function is given in [Syntax 13-2](#).

```

function_declaration ::= function [ lifetime ] function_body_declaration //from A.2.6
function_body_declaration ::=
    function_data_type_or_implicit
        [ interface_identifier . | class_scope ] function_identifier ;
    { tf_item_declaration }
    { function_statement_or_null }
    endfunction [ : function_identifier ]
| function_data_type_or_implicit
    [ interface_identifier . | class_scope ] function_identifier ( [ tf_port_list ] ) ;
    { block_item_declaration }
    { function_statement_or_null }
    endfunction [ : function_identifier ]
function_data_type_or_implicit ::=
    data_type_or_void
    | implicit_data_type
data_type ::= //from A.2.2.1
    integer_vector_type [ signing ] { packed_dimension }
    | integer_atom_type [ signing ]
    | non_integer_type
    | struct_union [ packed [ signing ] ] { struct_union_member { struct_union_member } }
        { packed_dimension }12
    | enum [ enum_base_type ] { enum_name_declaration { , enum_name_declaration } }
        { packed_dimension }
    | string
    | chandle
    | virtual [ interface ] interface_identifier
    | [ class_scope | package_scope ] type_identifier { packed_dimension }
    | class_type
    | event
    | ps_covergroup_identifier
    | type_reference13
signing ::= signed | unsigned
lifetime ::= static | automatic //from A.2.1.3

```

¹²⁾ When a packed dimension is used with the **struct** or **union** keyword, the **packed** keyword shall also be used.

¹³⁾ When a type_reference is used in a net declaration, it shall be preceded by a net type keyword; and when it is used in a variable declaration, it shall be preceded by the **var** keyword.

To indicate the return type of a function, its declaration can either include an explicit *data_type_or_void* or use an implicit syntax that indicates only the ranges of the packed dimensions and, optionally, the signedness. When the implicit syntax is used, the return type is the same as if the implicit syntax had been immediately preceded by the **logic** keyword. In particular, the implicit syntax can be empty, in which case the return type is a **logic** scalar. A function can also be **void**, without a return value (see [13.4.1](#)).

A function declaration has the formal arguments either in parentheses (like ANSI C) or in declarations and directions:

```
function logic [15:0] myfunc1(int x, int y);
...
endfunction

function logic [15:0] myfunc2;
  input int x;
  input int y;
  ...
endfunction
```

Functions can have the same formal arguments as tasks. Function argument directions are as follows:

```
input      // copy value in at beginning
output     // copy value out at end
inout     // copy in at beginning and out at end
ref        // pass reference (see 13.5.2)
```

Function declarations default to the formal direction **input** if no direction has been specified. Once a direction is given, subsequent formals default to the same direction. In the following example, the formal arguments *a* and *b* default to inputs, and *u* and *v* are both outputs:

```
function logic [15:0] myfunc3(int a, int b, output logic [15:0] u, v);
...
endfunction
```

Each formal argument has a data type that can be explicitly declared or inherited from the previous argument. If the data type is not explicitly declared, then the default data type is **logic** if it is the first argument or if the argument direction is explicitly specified. Otherwise the data type is inherited from the previous argument. An array can be specified as a formal argument to a function, for example:

```
function [3:0][7:0] myfunc4(input [3:0][7:0] a, b[3:0]);
...
endfunction
```

It shall be illegal to call a function with **output**, **inout**, or **ref** arguments in an event expression, in an expression within a procedural continuous assignment, or in an expression that is not within a procedural statement. However, a **const ref** function argument shall be legal in this context (see [13.5.2](#)).

Multiple statements can be written between the function header and **endfunction**. Statements are executed sequentially, as if they were enclosed in a **begin-end** group. It is also legal to have no statements at all, in which case the function returns the current value of the implicit variable that has the same name as the function.

13.4.1 Return values and void functions

The function definition shall implicitly declare a variable, internal to the function, with the same name as the function. This variable has the same type as the function return value. Function return values can be specified in two ways, either by using a **return** statement or by assigning a value to the internal variable with the same name as the function. For example:

```
function [15:0] myfunc1 (input [7:0] x,y);  
    myfunc1 = x * y - 1;    // return value assigned to function name  
endfunction  
  
function [15:0] myfunc2 (input [7:0] x,y);  
    return x * y - 1;    //return value is specified using return statement  
endfunction
```

The **return** statement shall override any value assigned to the function name. When the return statement is used, nonvoid functions shall specify an expression with the return.

A function return can be a structure or union. In this case, a hierarchical name used inside the function and beginning with the function name is interpreted as a member of the return value. If the function name is used outside the function, the name indicates the scope of the whole function. If the function name is used within a hierarchical name, it also indicates the scope of the whole function.

Functions can be declared as type **void**, which do not have a return value. Function calls may be used as expressions unless of type **void**, which are statements:

```
a = b + myfunc1(c, d); // call myfunc1 (defined above) as an expression  
  
myprint(a);           // call myprint (defined below) as a statement  
  
function void myprint (int a);  
    ...  
endfunction
```

Functions that return a value may be used in an assignment or an expression. Calling a nonvoid function as if it has no return value shall be legal, but shall issue a warning. The function can be used as a statement and the return value discarded without a warning by casting the function call to the **void** type.

```
void'(some_function());
```

It shall be illegal to declare another object with the same name as the function in the scope where the function is declared or explicitly imported. It shall also be illegal to declare another object with the same name as the function inside the function scope.

13.4.2 Static and automatic functions

Functions defined within a module, interface, program or package default to being static, with all declared items being statically allocated. These items shall be shared across all uses of the function executing concurrently.

Functions can be defined to use automatic storage in the following two ways:

- Explicitly declared using the optional automatic keyword as part of the function declaration.
- Implicitly declared by defining the function within a module, interface, program or package that is defined as automatic.

Functions defined within a class default to being automatic. Functions can be defined to use static storage by explicitly defining the task as static.

An automatic function is reentrant, with all the function declarations allocated dynamically for each concurrent function call. Automatic function items cannot be accessed by hierarchical references. Automatic functions can be invoked through the use of their hierarchical name.

Specific local variables can be declared as **automatic** within a static function or as **static** within an automatic function.

The following example defines a function called `factorial` that returns an integer value. The `factorial` function is called iteratively and the results are printed.

```

module tryfact;

    // define the function
    function automatic integer factorial (input [31:0] operand);
        integer i;
        if (operand >= 2)
            factorial = factorial (operand - 1) * operand;
        else
            factorial = 1;
        endfunction: factorial

    // test the function
    integer result;
    initial begin
        for (int n = 0; n <= 7; n++) begin
            result = factorial(n);
            $display("%0d factorial=%0d", n, result);
        end
    end
endmodule: tryfact

```

The simulation results are as follows:

```

0 factorial=1
1 factorial=1
2 factorial=2
3 factorial=6
4 factorial=24
5 factorial=120
6 factorial=720
7 factorial=5040

```

13.4.3 Constant functions

Constant functions are a subset of normal functions that shall meet the following constraints:

- A constant function shall not have output, inout, or ref arguments.
- A void function shall not be a constant function.
- A DPI import function (see [35.2.1](#)) shall not be a constant function.
- A constant function shall not contain a statement that directly schedules an event to execute after the function has returned.
- A constant function shall not contain any fork constructs.
- Constant functions shall contain no hierarchical references.

- Any function invoked within a constant function shall be a constant function local to the current module.
- It shall be legal to call any system function that is allowed in a constant_expression (see [11.2.1](#)). This includes \$bits and the array query functions. Calls to other system functions shall be illegal.
- All system task calls within a constant function shall be ignored.
- All parameter values used within the function shall be defined before the use of the invoking constant function call (i.e., any parameter use in the evaluation of a constant function call constitutes a use of that parameter at the site of the original constant function call). A constant function may reference parameters defined in packages or \$unit.
- All identifiers that are not parameters or functions shall be declared locally to the current function.
- If constant functions use any parameter value that is affected directly or indirectly by a defparam statement (see [23.10.1](#)), the result shall be undefined. This can produce an error or the constant function can return an indeterminate value.
- Constant functions shall not be declared inside a generate block (see [Clause 27](#)).
- Constant functions shall not themselves use constant functions in any context requiring a constant expression.
- A constant function may have default argument values (see [13.5.3](#)), but any such default argument value shall be a constant expression.

Constant function calls are used to support the building of complex calculations of values at elaboration time (see [3.12](#)). A constant function call is a function call of a constant function local to the calling module or from a package or \$unit where the arguments to the function are all constant expressions (see [11.2.1](#)).

Constant function calls are evaluated at elaboration time. Their execution has no effect on the initial values of the variables used either at simulation time or among multiple invocations of a function at elaboration time. In each of these cases, the variables are initialized as they would be for normal simulation.

The following example defines a function called clogb2 that returns an integer with the value of the ceiling of the log base 2.

```
module ram_model (address, write, chip_select, data);
  parameter data_width = 8;
  parameter ram_depth = 256;
  localparam addr_width = clogb2(ram_depth);
  input [addr_width - 1:0] address;
  input write, chip_select;
  inout [data_width - 1:0] data;

  //define the clogb2 function
  function integer clogb2 (input [31:0] value);
    value = value - 1;
    for (clogb2 = 0; value > 0; clogb2 = clogb2 + 1)
      value = value >> 1;
  endfunction

  logic [data_width - 1:0] data_store[0:ram_depth - 1];
  //the rest of the ram model
endmodule: ram_model
```

An instance of this ram_model with parameters assigned is as follows:

```
ram_model #(32,421) ram_a0(a_addr,a_wr,a_cs,a_data);
```

13.4.4 Background processes spawned by function calls

Functions shall execute with no delay. Thus, a process calling a function shall return immediately. Statements that do not block shall be allowed inside a function; specifically, nonblocking assignments, event triggers, clocking drives, and `fork-join_none` constructs shall be allowed inside a function.

Calling a function that tries to schedule an event that cannot become active until after that function returns shall be allowed provided that the thread calling the function is created by an initial procedure, always procedure, or fork block from one of those procedures and in a context in which a side effect is allowed. Implementations shall issue an error either at compile time or run time when these provisions have not been met.

Within a function, a `fork-join_none` construct may contain any statements that are legal within a task. Examples of a legal and illegal usage of `fork-join_none` in a function are shown below.

```

class IntClass;
  int a;
endclass

IntClass address=new(), stack=new();

function automatic bit watch_for_zero( IntClass p );
  fork
    forever @p.a begin
      if ( p.a == 0 ) $display ("Unexpected zero");
    end
  join_none
  return ( p.a == 0 );
endfunction

function bit start_check();
  return ( watch_for_zero( address ) | watch_for_zero( stack ) );
endfunction

bit y = watch_for_zero( stack );           // illegal

initial if ( start_check() ) $display ( "OK"); // legal

initial fork
  if (start_check() ) $display( "OK too");    // legal
join_none

```

13.5 Subroutine calls and argument passing

Tasks and void functions are called as statements within procedural blocks (see [9.2](#)). A nonvoid *function call* may be an operand within an expression.

The syntax for calling a subroutine as a statement is shown in [Syntax 13-3](#):

```

subroutine_call_statement ::=                                     //from A.6.9
  subroutine_call ;
  | void ' ( function_subroutine_call ) ;

subroutine_call ::=                                           //from A.8.2
  tf_call

```

```

| system_tf_call
| method_call
| [ std:: ] randomize_call
tf_call33 ::= ps_or_hierarchical_tf_identifier { attribute_instance } [ ( list_of_arguments ) ]
list_of_arguments ::=
  [ expression ] { , [ expression ] } { , . identifier ( [ expression ] ) }
  | . identifier ( [ expression ] ) { , . identifier ( [ expression ] ) }
ps_or_hierarchical_tf_identifier ::= [ package_scope ] tf_identifier | hierarchical_tf_identifier //from 4.9.3

```

- ³³) It shall be illegal to omit the parentheses in a `tf_call` unless the subroutine is a task, void function, or class method. If the subroutine is a nonvoid class function method, it shall be illegal to omit the parentheses if the call is directly recursive.

Syntax 13-3—Task or function call syntax (excerpt from [Annex A](#))

If an argument in the subroutine is declared as an **input**, then the corresponding expression in the subroutine call can be any expression. The order of evaluation of the expressions in the argument list is undefined.

If the argument in the subroutine is declared as an **output** or an **inout**, then the corresponding expression in the subroutine call shall be restricted to an expression that is valid on the left-hand side of a procedural assignment (see [10.4](#)).

The execution of the subroutine call shall pass input values from the expressions listed in the arguments of the call. Execution of the return from the subroutine shall pass values from the **output** and **inout** type arguments to the corresponding variables in the subroutine call.

SystemVerilog provides two means for passing arguments to tasks and functions: by value and by reference. Arguments can also be bound by name as well as by position. Subroutine arguments can also be given default values, allowing the call to the subroutine to not pass arguments.

13.5.1 Pass by value

Pass by value is the default mechanism for passing arguments to subroutines. This argument passing mechanism works by copying each argument into the subroutine area. If the subroutine is automatic, then the subroutine retains a local copy of the arguments in its stack. If the arguments are changed within the subroutine, the changes are not visible outside the subroutine. When the arguments are large, it can be undesirable to copy the arguments. Also, programs sometimes need to share a common piece of data that is not declared global.

For example, calling the function below copies 1000 bytes each time the call is made.

```

function automatic int crc( byte packet [1000:1] );
  for( int j= 1; j <= 1000; j++ ) begin
    crc ^= packet[j];
  end
endfunction

```

13.5.2 Pass by reference

Arguments passed by reference are not copied into the subroutine area, rather, a reference to the original argument is passed to the subroutine. The subroutine can then access the argument data via the reference. Arguments passed by reference shall be matched with equivalent data types (see [6.22.2](#)). No casting shall be permitted. To indicate argument passing by reference, the argument declaration is preceded by the **ref**

keyword. It shall be illegal to use argument passing by reference for subroutines with a lifetime of **static**. The general syntax is as follows:

```
subroutine( ref type argument );
```

For example, the example above can be written as follows:

```
function automatic int crc( ref byte packet [1000:1] );  
  for( int j= 1; j <= 1000; j++ ) begin  
    crc ^= packet[j];  
  end  
endfunction
```

As shown in the preceding example, no change other than addition of the **ref** keyword is needed. The compiler knows that `packet` is now addressed via a reference, but users do not need to make these references explicit either in the callee or at the point of the call. In other words, the call to either version of the `crc` function remains the same:

```
byte packet1[1000:1];  
int k = crc( packet1 ); // pass by value or by reference: call is the same
```

When the argument is passed by reference, both the caller and the subroutine share the same representation of the argument; therefore, any changes made to the argument, within either the caller or the subroutine, shall be visible to each other. The semantics of assignments to variables passed by reference is that changes are seen outside the subroutine immediately (before the subroutine returns).

Only the following shall be legal to pass by reference:

- a variable,
- a class property,
- a member of an unpacked structure, or
- an element of an unpacked array.

Nets and selects into nets shall not be passed by reference.

Because a variable passed by reference may be an automatic variable, a **ref** argument shall not be used in any context forbidden for automatic variables.

Elements of dynamic arrays, queues, and associative arrays that are passed by reference may get removed from the array or the array may get resized before the called subroutine completes. The specific array element passed by reference shall continue to exist within the scope of the called subroutines until they complete. Changes made to the values of array elements by the called subroutine shall not be visible outside the scope of those subroutines if those array elements were removed from the array before the changes were made. These references shall be called *outdated references*.

The following operations on a variable-size array shall cause existing references to elements of that array to become outdated references:

- A dynamic array is resized with an implicit or explicit **new** [] .
- A dynamic array is deleted with the `delete()` method.
- The element of an associative array being referenced is deleted with the `delete()` method.
- The queue or dynamic array containing the referenced element is updated by assignment.
- The element of a queue being referenced is deleted by a queue method.

Passing an argument by reference is a unique argument-passing qualifier, different from **input**, **output**, or **inout**. Combining **ref** with any other directional qualifier shall be illegal. For example, the following declaration results in a compiler error:

```
task automatic incr( ref input int a );// incorrect: ref cannot be qualified
```

A **ref** argument is similar to an **inout** argument except that an **inout** argument is copied twice: once from the actual into the argument when the subroutine is called and once from the argument into the actual when the subroutine returns. Passing object handles is no exception and has similar semantics when passed as **ref** or **inout** arguments. Thus, a **ref** of an object handle allows changes to the object handle (for example, assigning a new object) in addition to modification of the contents of the object.

To protect arguments passed by reference from being modified by a subroutine, the **const** qualifier can be used together with **ref** to indicate that the argument, although passed by reference, is a read-only variable.

```
task automatic show ( const ref byte data [] );  
  for ( int j = 0; j < data.size ; j++ )  
    $display( data[j] ); // data can be read but not written  
endtask
```

When the formal argument is declared as a **const ref**, the subroutine cannot alter the variable, and an attempt to do so shall generate a compiler error.

13.5.3 Default argument values

To handle common cases or allow for unused arguments, SystemVerilog allows a subroutine declaration to specify a default value for each singular argument.

The syntax to declare a default argument in a subroutine is as follows:

```
subroutine( [ direction ] [ type ] argument = default_expression);
```

The optional direction can be **input**, **inout**, **output**, or **ref**.

The *default expression* is evaluated in the scope containing the subroutine declaration each time a call using the default is made. If the default is not used, the default expression is not evaluated. The use of defaults shall only be allowed with the ANSI style declarations.

When the subroutine is called, arguments with defaults can be omitted from the call, and the compiler shall insert their corresponding values. Unspecified (or empty) arguments can be used as placeholders for default arguments. If an unspecified argument is used for an argument that does not have a default, a compiler error shall be issued.

```
task read(int j = 0, int k, int data = 1 );  
  ...  
endtask
```

This example declares a task `read()` with two default arguments, `j` and `data`. The task can then be called using various default arguments:

```
read( , 5 );           // is equivalent to read( 0, 5, 1 );  
read( 2, 5 );         // is equivalent to read( 2, 5, 1 );  
read( , 5, 7 );       // is equivalent to read( 0, 5, 7 );  
read( 1, 5, 2 );      // is equivalent to read( 1, 5, 2 );
```

```
read( );           // error; k has no default value
read( 1, , 7 );   // error; k has no default value
```

The following example shows an output argument with a default expression:

```
module m;
  logic a, w;

  task t1 (output o = a) ; // default binds to m.a
    ...
  endtask :t1

  task t2 (output o = b) ; // illegal, b cannot be resolved
    ...
  endtask :t2

  task t3 (inout io = w) ; // default binds to m.w
    ...
  endtask :t1
endmodule :m

module n;
  logic a;

  initial begin
    m.t1(); // same as m.t1(m.a), not m.t1(n.a);
            // at end of task, value of t1.o is copied to m.a
    m.t3(); // same as m.t3(m.w)
            // value of m.w is copied to t3.io at start of task and
            // value of t3.io is copied to m.w at end of task
  end
endmodule :n
```

13.5.4 Argument binding by name

SystemVerilog allows arguments to tasks and functions to be bound by name as well as by position. This allows specifying nonconsecutive default arguments and easily specifying the argument to be passed at the call. For example:

```
function int fun( int j = 1, string s = "no" );
  ...
endfunction
```

The `fun` function can be called as follows:

```
fun( .j(2), .s("yes") ); // fun( 2, "yes" );
fun( .s("yes") );       // fun( 1, "yes" );
fun( , "yes" );        // fun( 1, "yes" );
fun( .j(2) );          // fun( 2, "no" );
fun( .s("yes"), .j(2) ); // fun( 2, "yes" );
fun( .s(), .j() );     // fun( 1, "no" );
fun( 2 );              // fun( 2, "no" );
fun( );                // fun( 1, "no" );
```

If the arguments have default values, they are treated like parameters to module instances. If the arguments do not have a default, then they shall be given, or the compiler shall issue an error.

If both positional and named arguments are specified in a single subroutine call, then all the positional arguments shall come before the named arguments. Then, using the same example as above:

```
fun( .s("yes"), 2 );      // illegal  
fun( 2, .s("yes") );    // OK
```

13.5.5 Optional argument list

When a void function or class function method specifies no arguments, the empty parenthesis, (), following the subroutine name shall be optional. This is also true for tasks, void functions, and class methods that require arguments, when all arguments have defaults specified. It shall be illegal to omit the parenthesis in a directly recursive nonvoid class function method call that is not hierarchically qualified.

13.6 Import and export functions

SystemVerilog provides a direct programming interface (DPI) that allows importing foreign language subroutines, such as C functions, into SystemVerilog. An imported subroutine is called in the same way as a SystemVerilog subroutine. SystemVerilog tasks and functions can also be exported to a foreign language. See [Clause 35](#) for details on the DPI.

13.7 Task and function names

Task and function names are resolved following slightly different rules than other references. Even when used as a simple name, a task or function name follows a modified form of the upwards hierarchical name resolution rules. This means that “forward” references to a task or function defined later in the same or an enclosing scope can be resolved. See [23.8.1](#) for the rules that govern task and function name resolution.

14. Clocking blocks

14.1 General

This clause describes the following:

- Clocking block declarations
- Input and output skews
- Clocking block signal events
- Cycle delays
- Synchronous events
- Synchronous drives

14.2 Overview

Module port connections and interfaces can specify the signals or nets through which a testbench communicates with a device under test (DUT). However, such specification does not explicitly denote any timing disciplines, synchronization requirements, or clocking paradigms.

The *clocking block* construct identifies clock signals and captures the timing and synchronization requirements of the blocks being modeled. A clocking block is defined between the keywords **clocking** and **endclocking**.

A clocking block assembles signals that are synchronous to a particular clock and makes their timing explicit. The clocking block is a key element in a cycle-based methodology, which enables users to write testbenches at a higher level of abstraction. Rather than focusing on signals and transitions in time, the test can be defined in terms of cycles and transactions. Depending on the environment, a testbench can contain one or more clocking blocks, each containing its own clock plus an arbitrary number of signals.

The clocking block separates the timing and synchronization details from the structural, functional, and procedural elements of a testbench. Thus, the timing for sampling and driving clocking block signals is implicit and relative to the clocking block's clock. This enables a set of key operations to be written very succinctly, without explicitly using clocks or specifying timing. These operations are as follows:

- Synchronous events
- Input sampling
- Synchronous drives

14.3 Clocking block declaration

The syntax for the clocking block is as follows in [Syntax 14-1](#).

```
clocking_declaration ::= // from A.6.11
    [ default ] clocking [ clocking_identifier ] clocking_event ;
    { clocking_item }
    endclocking [ : clocking_identifier ]
    | global clocking [ clocking_identifier ] clocking_event ; endclocking [ : clocking_identifier ]

clocking_event ::=
    @ identifier
    | @ ( event_expression )
```

```
clocking_item ::=
    default default_skew ;
    | clocking_direction list_of_clocking_decl_assign ;
    | { attribute_instance } assertion_item_declaration
default_skew ::=
    input clocking_skew
    | output clocking_skew
    | input clocking_skew output clocking_skew
clocking_direction ::=
    input [ clocking_skew ]
    | output [ clocking_skew ]
    | input [ clocking_skew ] output [ clocking_skew ]
    | inout
list_of_clocking_decl_assign ::= clocking_decl_assign { , clocking_decl_assign }
clocking_decl_assign ::= signal_identifier [ = expression ]
clocking_skew ::=
    edge_identifier [ delay_control ]
    | delay_control
edge_identifier ::= posedge | negedge | edge // from A.7.4
delay_control ::= // from A.6.5
    # delay_value
    | # ( mintymax_expression )
```

Syntax 14-1—Clocking block syntax (excerpt from [Annex A](#))

The *delay_control* shall be either a time literal or a constant expression that evaluates to a positive integer value.

The *clocking_identifier* specifies the name of the clocking block being declared. Only default clocking blocks may be unnamed. Declarations in unnamed clocking blocks may not be referenced.

The *signal_identifier* specifies a signal (a net or variable) in the scope enclosing the clocking block declaration, and defines a *clockvar* in the clocking block. The specified signal is called a *clocking signal*. Unless a hierarchical expression is used, both the clocking signal and the clockvar names shall be the same. It shall be illegal for a clocking signal to designate a variable restricted to a procedural block (see [6.21](#)).

The *clocking_event* designates a particular event to act as the clock for the clocking block. The timing used to drive and sample all other signals specified in a given clocking block is governed by its clocking event. See [14.13](#) and [14.16](#) for details on the precise timing semantics of sampling and driving clocking signals. Bidirectional signals (inout) are sampled as well as driven. An output signal cannot be read, and an input signal cannot be driven.

The *clocking_skew* determines how many time units away from the clock event a signal is to be sampled or driven. Input skews are implicitly negative, that is, they always refer to a time before the clock, whereas output skews always refer to a time after the clock (see [14.4](#)). When the clocking event specifies a simple edge, instead of a number, the skew can be specified as the specific edge of the signal. A single skew can be specified for the entire block by using a **default** clocking item.

```
clocking ck1 @(posedge clk);
    default input #1step output negedge; // legal
    // outputs driven on the negedge clk
    input ... ;
```

```

    output ... ;
endclocking

clocking ck2 @(clk); // no edge specified!
    default input #1step output negedge; // legal
    input ... ;
    output ... ;
endclocking

```

The *hierarchical_identifier* specifies that, instead of a local port, the signal to be associated with the clocking block is specified by its hierarchical name (cross-module reference).

Example:

```

clocking bus @(posedge clock1);
    default input #10ns output #2ns;
    input data, ready, enable = top.mem1.enable;
    output negedge ack;
    input #1step addr;
endclocking

```

In the above example, the first line declares a clocking block called `bus` that is to be clocked on the positive edge of the signal `clock1`. The second line specifies that by default all signals in the clocking block shall use a 10ns input skew and a 2ns output skew. The next line adds three input signals to the clocking block: `data`, `ready`, and `enable`; the last signal refers to the hierarchical signal `top.mem1.enable`. The fourth line adds the signal `ack` to the clocking block and overrides the default output skew so that `ack` is driven on the negative edge of the clock. The last line adds the signal `addr` and overrides the default input skew so that `addr` is sampled one step before the positive edge of the clock.

Unless otherwise specified, the default `input` skew is `1step` and the default `output` skew is `0`. A step is a special time unit whose value is defined in 3.14.3. A `1step` input skew allows input signals to sample their steady-state values in the time step immediately before the clock event (i.e., in the preceding Postponed region).

14.4 Input and output skews

Input (or inout) signals are sampled at the designated clock event. If an input skew is specified, then the signal is sampled at *skew* time units *before* the clock event. Similarly, output (or inout) signals are driven *skew* simulation time units *after* the corresponding clock event. [Figure 14-1](#) shows the basic sample and drive timing for a positive edge clock.

A skew shall be a constant expression and can be specified as a parameter. If the skew does not specify a time unit, the current time unit is used. If a number is used, the skew is interpreted using the timescale of the current scope.

```

clocking dram @(clk);
    input #1ps address;
    input #5 output #6 data;
endclocking

```

An input skew of `1step` indicates that the signal is to be sampled at the end of the previous time step. In other words, the value sampled is always the signal's last value immediately before the corresponding clock edge.

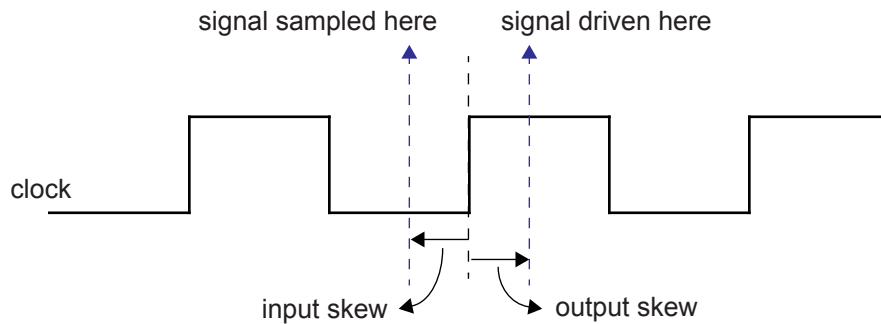

Figure 14-1—Sample and drive times including skew with respect to the positive edge of the clock

NOTE—A clocking block does not eliminate potential races when an event control outside a program block is sensitive to the same clock as the clocking block and a statement after the event control attempts to read a member of the clocking block. The race is between reading the old sampled value and the new sampled value.

Inputs with explicit #0 skew shall be sampled at the same time as their corresponding clocking event, but to avoid races, they are sampled in the Observed region. Likewise, clocking block outputs with no skew (or explicit #0 skew) shall be driven at the same time as their specified clocking event, in the Re-NBA region.

Skews are declarative constructs; thus, they are semantically very different from the syntactically similar procedural delay statement. In particular, an explicit #0 skew does not suspend any process, nor does it execute or sample values in the Inactive region.

14.5 Hierarchical expressions

Any signal in a clocking block can be associated with an arbitrary hierarchical expression. As described in [14.3](#), a hierarchical expression is introduced by appending an equal sign (=) followed by the hierarchical expression:

```
clocking cd1 @(posedge phil);
    input #1step state = top.cpu.state;
endclocking
```

However, hierarchical expressions are not limited to simple names or signals in other scopes. They can be used to declare slices and concatenations (or combinations thereof) of signals in other scopes or in the current scope.

```
clocking mem @(clock);
    input instruction = { opcode, regA, regB[3:1] };
endclocking
```

In a clocking block, any expression assigned to a signal in its declaration shall be an expression that would be legal in a port connection to a port of appropriate direction. Any expression assigned to a signal in a clocking **input** or **inout** declaration shall be an expression that would be legal for connection to a module's input port. Any expression assigned to a signal in a clocking **output** or **inout** declaration shall be an expression that would be legal for connection to a module's output port.

A clocking `inout` declaration is not an `inout` port; it is shorthand for two clocking declarations, one input and one output, with the same signal. Consequently, such a signal must meet the requirements for both a clocking input and a clocking output, but it is not required to meet the stricter requirements for connection to a module's `inout` port. In particular, it is acceptable to specify a variable as a clocking `inout` signal.

14.6 Signals in multiple clocking blocks

The same signals—clock, inputs, inouts, or outputs—can appear in more than one clocking block. When clocking blocks use the same clock (or clocking expression), they shall share the same synchronization event, in the same manner as several latches can be controlled by the same clock. Input semantics are described in [14.13](#), and output semantics is described in [14.16](#).

14.7 Clocking block scope and lifetime

A clocking block is both a declaration and an instance of that declaration. A separate instantiation step is not necessary. Instead, one copy is created for each instance of the block containing the declaration (like an always procedure). Once declared, the clocking signals are available via the clocking block name and the dot (`.`) operator:

```
dom.sig // signal sig in clocking dom
```

Multiple clocking blocks cannot be nested. They cannot be declared inside functions, tasks, or packages or outside all declarations in a compilation unit. A clocking block can only be declared inside a module, interface, checker, or program (see [Clause 24](#)).

A clocking block has static lifetime and scope local to its enclosing module, interface, or program.

14.8 Multiple clocking blocks example

In this example, a simple test program includes two clocking blocks. The program construct used in this example is discussed in [Clause 24](#).

```
program test( input phi1, input [15:0] data, output logic write,
             input phi2, inout [8:1] cmd, input enable
             );
  reg [8:1] cmd_reg;

  clocking cd1 @(posedge phi1);
    input data;
    output write;
    input state = top.cpu.state;
  endclocking

  clocking cd2 @(posedge phi2);
    input #2 output #4ps cmd;
    input enable;
  endclocking

  initial begin
    // program begins here
    ...
    // user can access cd1.data , cd2.cmd , etc...
  end
  assign cmd = enable ? cmd_reg : 'x;
```

```
endprogram
```

The test program can be instantiated and connected to a DUT (cpu and mem).

```
module top;
  logic phi1, phi2;
  wire [8:1] cmd; // cannot be logic (two bidirectional drivers)
  logic [15:0] data;

  test main( phi1, data, write, phi2, cmd, enable );
  cpu cpu1( phi1, data, write );
  mem mem1( phi2, cmd, enable );
endmodule
```

14.9 Interfaces and clocking blocks

A clocking block encapsulates a set of signals that share a common clock; therefore, specifying a clocking block using a SystemVerilog **interface** (see [Clause 25](#)) can significantly reduce the amount of code needed to connect the testbench. Furthermore, because the signal directions in the clocking block within the testbench are with respect to the testbench and not the design under test, a **modport** declaration (see [25.5](#)) can appropriately describe either direction. A testbench program can be contained within a program, and its ports can be interfaces that correspond to the signals declared in each clocking block. The interface's wires shall have the same direction as specified in the clocking block when viewed from the testbench side (i.e., **modport test**) and reversed when viewed from the DUT (i.e., **modport dut**).

For example, the previous example could be rewritten using interfaces as follows:

```
interface bus_A (input clk);
  logic [15:0] data;
  logic write;
  modport test (input data, output write);
  modport dut (output data, input write);
endinterface

interface bus_B (input clk);
  logic [8:1] cmd;
  logic enable;
  modport test (input enable);
  modport dut (output enable);
endinterface

program test( bus_A.test a, bus_B.test b );

  clocking cd1 @(posedge a.clk);
    input data = a.data;
    output write = a.write;
    inout state = top.cpu.state;
  endclocking

  clocking cd2 @(posedge b.clk);
    input #2 output #4ps cmd = b.cmd;
    input en = b.enable;
  endclocking

  initial begin
    // program begins here
    ...
  end
```

```

        // user can access cd1.data, cd1.write, cd1.state,
        // cd2.cmd, and cd2.en
    end
endprogram

```

The test module can be instantiated and connected as before:

```

module top;
    logic phi1, phi2;

    bus_A a(phi1);
    bus_B b(phi2);

    test main( a, b );
    cpu cpu1( a );
    mem mem1( b );
endmodule

```

14.10 Clocking block events

The clocking event of a clocking block is available directly by using the clocking block name, regardless of the actual clocking event used to declare the clocking block.

For example:

```

clocking dram @(posedge phi1);
    inout data;
    output negedge #1 address;
endclocking

```

The clocking event of the `dram` clocking block can be used to wait for that particular event:

```
@( dram );
```

The above statement is equivalent to `@(posedge phi1)`.

14.11 Cycle delay:

The `##` operator can be used to delay execution by a specified number of clocking events or clock cycles.

The syntax for the cycle delay statement is as follows in [Syntax 14-2](#).

```

procedural_timing_control_statement ::= // from A.6.5
    procedural_timing_control_statement_or_null
procedural_timing_control ::=
    ...
    | cycle_delay
cycle_delay ::= // from A.6.11
    ## integral_number
    | ## identifier
    | ## ( expression )

```

Syntax 14-2—Cycle delay syntax (excerpt from [Annex A](#))

The *expression* can be any SystemVerilog expression that evaluates to a positive integer value.

What constitutes a cycle is determined by the default clocking in effect (see [14.12](#)). If no default clocking has been specified for the current module, interface, checker, or program, then the compiler shall issue an error.

Example:

```
##5;          // wait 5 cycles (clocking events) using the default clocking

##(j + 1);   // wait j+1 cycles (clocking events) using the default clocking
```

The cycle delay timing control shall wait for the specified number of clocking events. This implies that for a ##1 statement that is executed at a simulation time that is not coincident with the associated clocking event, the calling process shall be delayed a fraction of the associated clock cycle.

Cycle delays of ##0 are treated specially. If a clocking event has not yet occurred in the current time step, a ##0 cycle delay shall suspend the calling process until the clocking event occurs. When a process executes a ##0 cycle delay and the associated clocking event has already occurred in the current time step, the process shall continue execution without suspension. When used on the right-hand side of a synchronous drive, a ##0 cycle delay shall have no effect, as if it were not present.

Cycle delay timing controls shall not be legal for use in intra-assignment delays in either blocking or non-blocking assignment statements.

14.12 Default clocking

One clocking block can be specified as the default for all cycle delay operations within a given module, interface, program, or checker.

The syntax for default clocking specification statement is as follows in [Syntax 14-3](#).

```
module_or_generate_item_declaration ::=                               //from A.1.4
...
| default clocking clocking_identifier ;
...
checker_or_generate_item_declaration ::=                             //from A.1.8
...
| default clocking clocking_identifier ;
...
clocking_declaration ::=                                           //from A.6.11
[ default ] clocking [ clocking_identifier ] clocking_event ;
  { clocking_item }
endclocking [ : clocking_identifier ]
...
```

Syntax 14-3—Default clocking syntax (excerpt from [Annex A](#))

The *clocking_identifier* shall be the name of a clocking block.

Only one default clocking can be specified in a module, interface, program, or checker. Specifying a default clocking more than once in the same module, interface, program, or checker shall result in a compiler error.

A default clocking is valid only within the scope containing the default clocking specification statement. This scope includes the module, interface, program, or checker that contains the declaration as well as any nested modules, interfaces, or checkers. It does not include instantiated modules, interfaces, or checkers.

Example 1: Declaring a clocking as the default:

```

program test( input logic clk, input logic [15:0] data );
  default clocking bus @(posedge clk);
  inout data;
endclocking

  initial begin
    ## 5;
    if ( bus.data == 10 )
      ## 1;
    else
      ...
  end
endprogram

```

Example 2: Assigning an existing clocking to be the default:

```

module processor ...
  clocking busA @(posedge clk1); ... endclocking
  clocking busB @(negedge clk2); ... endclocking
  module cpu( interface y );
    default clocking busA ;
    initial begin
      ## 5; // use busA => (posedge clk1)
      ...
    end
  endmodule
endmodule

```

14.13 Input sampling

All clocking block inputs (input or inout) are sampled at the corresponding clocking event. If the input skew is not an explicit #0, then the value sampled corresponds to the signal value at the Postponed region of the time step skew time units prior to the clocking event (see [Figure 14-1](#) in [14.4](#)). If the input skew is an explicit #0, then the value sampled corresponds to the signal value in the Observed region. In this case, the newly sampled values shall be available for reading at the end of the Observed region processing. If upon processing the Re-Active region, the simulation must process Active events without advancing time (thereby executing the Observed region more than once), clocking inputs sampled with #0 skew shall not be resampled unless a new clocking event occurs in the active region set.

NOTE—When the clocking event is triggered by the execution of a program, there is a potential race between the update of a clocking block input value and programs that read that value without synchronizing with the corresponding clocking event. This race does not exist when the clocking block event is triggered from within a module.

Upon processing its specified clocking event, a clocking block shall update its sampled values before triggering the event associated with the clocking block name. This event shall be triggered in the Observed region. Thus, a process that waits for the clocking block itself is guaranteed to read the updated sampled values, regardless of the scheduling region in which either the waiting or the triggering processes execute. For example:

```

clocking cb @(negedge clk);
  input v;

```

```
endclocking

always @(cb) $display(cb.v);

always @(negedge clk) $display(cb.v);
```

The first **always** procedure above is guaranteed to display the updated sampled value of signal *v*. In contrast, the second **always** exhibits a potential race, and may display the old or the newly updated sampled value.

When an **input** or **inout** clockvar appears in any expression its value is the signal's sampled value. That is, the value that the clocking block sampled at the most recent clocking event.

When the same signal is an input to multiple clocking blocks, the semantics is straightforward; each clocking block samples the corresponding signal with its own clocking event.

14.14 Global clocking

One clocking block may be declared as the global clocking for an entire elaborated SystemVerilog model.

The syntax for the global clocking declaration is as follows in [Syntax 14-4](#).

```
clocking_declaration ::= // from A.6.11
...
| global clocking [ clocking_identifier ] clocking_event ; endclocking [ : clocking_identifier ]
```

Syntax 14-4—Global clocking syntax (excerpt from [Annex A](#))

There shall be at most one **global clocking** declaration anywhere in an entire elaborated SystemVerilog model. It shall be an error if there is more than one such **global clocking** declaration. It shall be an error to place a global clocking declaration within a program block.

The system function `$global_clock` returns the event expression specified in the unique **global clocking** declaration. The function has no arguments. It shall be an error to invoke the `$global_clock` system function if there is no global clocking declaration in the elaborated SystemVerilog model. Otherwise, `$global_clock` may be invoked anywhere that a clocking event may be specified.

The main purpose of global clocking is to specify which clocking event in simulation corresponds to the primary clock used in formal verification.

The following is an example of a **global clocking** declaration:

```
module top;
  logic clk1, clk2;
  global clocking sys @(clk1 or clk2); endclocking
  // ...
endmodule
```

In this example, `sys` is declared as the global clocking event and is defined to occur if, and only if, there is a change of either of two signals, `clk1` and `clk2`. Specification of the name `sys` in the global clocking declaration is optional since the global clocking event may be referenced by `$global_clock` from anywhere in the SystemVerilog model.

Any *clocking_event* may be specified in a **global clocking** declaration.

14.15 Synchronous events

Explicit synchronization is done via the event control operator, @, which allows a process to wait for a particular signal value change or a clocking event (see [14.10](#)).

The syntax for the synchronization operator is given in [9.4.2](#).

The expression used with the event control can denote clocking block input (**input** or **inout**) or a slice thereof. Slices can include dynamic indices, which are evaluated once when the @ expression executes.

These are some examples of synchronization statements:

- Wait for the next change of signal `ack_1` of clocking block `ram_bus`
`@(ram_bus.ack_1);`
- Wait for the next clocking event in clocking block `ram_bus`
`@(ram_bus);`
- Wait for the positive edge of the signal `ram_bus.enable`
`@(posedge ram_bus.enable);`
- Wait for the falling edge of the specified 1-bit slice `dom.sign[a]`
`@(negedge dom.sign[a]);`
NOTE—The index `a` is evaluated at run time.
- Wait for either the next positive edge of `dom.sig1` or the next change of `dom.sig2`, whichever happens first
`@(posedge dom.sig1 or dom.sig2);`
- Wait for either the negative edge of `dom.sig1` or the positive edge of `dom.sig2`, whichever happens first
`@(negedge dom.sig1 or posedge dom.sig2);`
- Wait for the edge (either the negative edge or the positive edge, whichever happens first) of `dom.sig1`.
`@(edge dom.sig1);`
Or equivalently
`@(negedge dom.sig1 or posedge dom.sig1);`

The values used by the synchronization event control are the synchronous values, that is, the values sampled at the corresponding clocking event.

14.16 Synchronous drives

Clocking block outputs (**output** or **inout**) are used to drive values onto their corresponding signals, but at a specified time. In other words, the corresponding signal changes value at the indicated clocking event as modified by the output skew.

For zero skew clocking block outputs with no cycle delay, synchronous drives shall schedule new values in the Re-NBA region of the time step corresponding to the clocking event. For clocking block outputs with non-zero skew, or drives with non-zero cycle delay, the corresponding signal shall be scheduled to change value in the Re-NBA region of a future time step.

For each clocking block output whose target is a net, a driver on that net shall be created. The driver so created shall have (**strong1**, **strong0**) drive strength and shall be updated as if by a continuous assignment from a variable inside the clocking block. This implicit variable, which is invisible to user code, shall be updated in the Re-NBA region by the execution of a synchronous drive to the corresponding clockvar. The created driver shall be initialized to 'z', hence, the driver has no influence on its target net until a synchronous drive is performed to the corresponding clockvar.

The syntax to specify a synchronous drive is similar to an assignment and is shown in [Syntax 14-5](#).

```

statement ::= [ block_identifier : ] { attribute_instance } statement_item           //from A.6.4
statement_item ::=
    ...
    | clocking_drive ;
clocking_drive ::=                                                                    //from A.6.11
    clockvar_expression <= [ cycle_delay ] expression
cycle_delay ::= ## expression
clockvar ::= hierarchical_identifier
clockvar_expression ::= clockvar select
  
```

Syntax 14-5—Synchronous drive syntax (excerpt from [Annex A](#))

The *clockvar_expression* is a bit-select, slice, or the entire clocking block output whose corresponding signal is to be driven (concatenation is not allowed):

```

dom.sig           // entire clockvar
dom.sig[2]        // bit-select
dom.sig[8:2]      // slice
  
```

The *expression* (in the *clocking_drive* production) can be any valid expression that is assignment compatible with the type of the corresponding signal.

The optional *cycle_delay* construct, appearing on the right-hand side of a *clocking_drive* statement, is syntactically similar to an intra-assignment delay in a nonblocking assignment. Like a nonblocking intra-assignment delay, it shall not cause execution of the statement to block. The right-hand side expression shall be evaluated immediately even when a *cycle_delay* is present. However, updating of the target signal shall be postponed for the specified number of cycles of the target clockvar's clocking block, plus any clocking output skew specified for that clockvar.

No other form of intra-assignment delay syntax shall be legal in a synchronous drive to a clockvar.

A procedural cycle delay, as described in [14.11](#), can be used as a prefix to any procedural statement. If a procedural cycle delay is used as a prefix to a synchronous drive, it shall block for its specified number of cycles of the default clocking exactly as it would if used as a prefix to any other procedural statement.

Examples:

```

bus.data[3:0] <= 4'h5; // drive data in Re-NBA region of the current cycle

##1 bus.data <= 8'hz; // wait 1 default clocking cycle, then drive data

##2; bus.data <= 2; // wait 2 default clocking cycles, then drive data

bus.data <= ##2 r; // remember the value of r and then drive
// data 2 (bus) cycles later

bus.data <= #4 r; // error: regular intra-assignment delay not allowed
// in synchronous drives

```

Regardless of whether the synchronous drive takes effect on the current clocking event or at some future clocking event as a result of a *cycle_delay*, the corresponding signal shall be updated at a time after that clocking event as specified by the output skew.

It is possible for a drive statement to execute at a time that is not coincident with its clocking event. Such drive statements shall execute without blocking, but shall perform their drive action as if they had executed at the time of the next clocking event. The expression on the right-hand side of the drive statement shall be evaluated immediately, but the processing of the drive is delayed until the time of the next clocking event.

For example:

```

default clocking cb @(posedge clk); // Assume clk has a period of #10 units
output v;
endclocking

initial begin
    #3 cb.v <= expr1; // Matures in cycle 1; equivalent to ##1 cb.v <= expr1
end

```

It shall be an error to write to a clockvar except by using the synchronous drive syntax described in this sub-clause. Thus, it is illegal to use any continuous assignment, force statement, or procedural continuous assignment to write to a clockvar.

14.16.1 Drives and nonblocking assignments

Although synchronous drives use the same operator syntax as nonblocking variable assignments, they are not the same. One difference is that synchronous drives do not support intra-assignment delay syntax. A key feature of synchronous drives to inout clockvars is that a drive does not change the clocking block input. This is because reading the input always yields the last sampled value, and not the driven value.

For example, consider the following code:

```

clocking cb @(posedge clk);
    inout a;
    output b;
endclocking

initial begin
    cb.a <= c; // The value of a will change in the Re-NBA region
    cb.b <= cb.a; // b is assigned the value of a before the change
end

```

14.16.2 Driving clocking output signals

When more than one synchronous drive on the same clocking block output (or inout) is scheduled to mature in the same Re-NBA region of the same time step, the last value is the only value driven onto the output signal. This is true whether the synchronous drives execute at times coincident with clocking events, or at times in between clocking events (within the same clock cycle).

For example:

```

default clocking pe @(posedge clk);
  output nibble;    // four bit output
endclocking

initial begin
  ##2;
  pe.nibble <= 4'b0101;
  pe.nibble <= 4'b0011;
end

```

The driven value of `nibble` is `4'b0011`, regardless of whether `nibble` is a variable or a net.

It is possible for the scheduling loop described in 4.4 to iterate through the Re-NBA region more than once in a given time step. If this happens, synchronous drives will cause their associated clocking signal to glitch (i.e., change value more than once in a time step) if they assign different values to their associated clockvar in different iterations of the scheduling loop.

In the following example, variable `a` will glitch `1 -> 0 -> 1` at the first posedge of `clk`.

```

module m;
  bit a = 1'b1;
  default clocking cb @(posedge clk);
  output a;
endclocking

  initial begin
    ## 1;
    cb.a <= 1'b0;
    @(x); // x is triggered by reactive stimulus running in same time step
    cb.a <= 1'b1;
  end
endmodule

```

If a given clocking output is driven by multiple synchronous drives that are scheduled to mature at different future times due to the use of cycle delay, the drives shall each mature in their corresponding future cycles.

For example:

```

bit v;
default clocking cb @(posedge clk);
  output v;
endclocking

initial begin
  ##1;                                // Wait until cycle 1
  cb.v <= expr1;                        // Matures in cycle 1, v is assigned expr1
  cb.v <= ##2 expr2;                   // Matures in cycle 3
  #1 cb.v <= ##2 expr3;                // Matures in cycle 3
end

```

```

    ##1 cb.v <= ##1 expr4; // Matures in cycle 3, v is assigned expr4
end

```

When the same variable is an output from multiple clocking blocks, the last drive determines the value of the variable. This allows a single module to model multirate devices, such as a DDR memory, using a different **clocking** block to model each active edge. For example:

```

reg j;

clocking pe @(posedge clk);
    output j;
endclocking

clocking ne @(negedge clk);
    output j;
endclocking

```

The variable *j* is an output from two clocking blocks using different clocking events, **@(posedge clk)** versus **@(negedge clk)**. When driven, the variable *j* shall take on the value most recently assigned by either **clocking** block. A clocking block output only assigns a value to its associated signal in clock cycles where a synchronous drive occurs.

With the **edge** event, this is equivalent to the following simplified declaration:

```

reg j;
clocking e @(edge clk);
    output j;
endclocking

```

Multiple clocking block outputs driving a net cause the net to be driven to its resolved signal value. As described in [14.16](#) above, when a clocking block output corresponds to a net, a driver on that net is created. This semantic model applies to each clocking block output that drives the net. The driving values of all these driver(s), together with any other drivers on the net, shall be resolved as determined by the net's type.

It is possible to use a procedural assignment to assign to a signal associated with an output clockvar. When the associated signal is a variable, the procedural assignment assigns a new value to the variable, and the variable shall hold that value until another assignment occurs (either from a drive to a clocking block output, or another procedural assignment).

If a synchronous drive and a procedural nonblocking assignment write to the same variable in the same time step, the writes shall take place in an arbitrary order.

It shall be illegal to write to a variable with a continuous assignment, a procedural continuous assignment, or a primitive when that variable is associated with an output clockvar.

15. Interprocess synchronization and communication

15.1 General

This clause describes the following:

- Semaphores
- Mailboxes
- Named events

15.2 Overview

High-level and easy-to-use synchronization and communication mechanisms are essential to control the kinds of interactions that occur between dynamic processes used to model a complex system or a highly reactive testbench.

The basic synchronization mechanism is the named event type, along with the event trigger and event control constructs (i.e., `->` and `@`). This type of control is limited to static objects. It is adequate for synchronization at the hardware level and simple system-level, but falls short of the needs of a highly dynamic, reactive testbench.

SystemVerilog also provides a powerful and easy-to-use set of synchronization and communication mechanisms which can be created and reclaimed dynamically. This set comprises of a semaphore built-in class, which can be used for synchronization and mutual exclusion to shared resources, and a mailbox built-in class, which can be used as a communication channel between processes.

Semaphores and mailboxes are built-in types; nonetheless, they are classes and can be used as base classes for deriving additional higher level classes. These built-in classes reside in the built-in `std` package (see [26.7](#)); thus, they can be redefined by user code in any other scope.

15.3 Semaphores

Conceptually, a semaphore is a bucket. When a semaphore is allocated, a bucket that contains a fixed number of keys is created. Processes using semaphores must first procure a key from the bucket before they can continue to execute. If a specific process requires a key, only a fixed number of occurrences of that process can be in progress simultaneously. All others must wait until a sufficient number of keys is returned to the bucket. Semaphores are typically used for mutual exclusion, access control to shared resources, and basic synchronization.

An example of creating a semaphore is as follows:

```
semaphore smTx;
```

Semaphore is a built-in class that provides the following methods:

- Create a semaphore with a specified number of keys: `new()`
- Obtain one or more keys from the bucket: `get()`
- Return one or more keys into the bucket: `put()`
- Try to obtain one or more keys without blocking: `try_get()`

15.3.1 New()

Semaphores are created with the `new()` method.

The prototype for `new()` is as follows:

```
function new(int keyCount = 0 );
```

The `keyCount` specifies the number of keys initially allocated to the semaphore bucket. The number of keys in the bucket can increase beyond `keyCount` when more keys are put into the semaphore than are removed. The default value for `keyCount` is 0.

The `new()` function returns the semaphore handle.

15.3.2 Put()

The semaphore `put()` method is used to return keys to a semaphore.

The prototype for `put()` is as follows:

```
function void put(int keyCount = 1);
```

The `keyCount` specifies the number of keys being returned to the semaphore. The default is 1.

When the `semaphore.put()` function is called, the specified number of keys is returned to the semaphore. If a process has been suspended waiting for a key, that process shall execute if enough keys have been returned.

15.3.3 Get()

The semaphore `get()` method is used to procure a specified number of keys from a semaphore.

The prototype for `get()` is as follows:

```
task get(int keyCount = 1);
```

The `keyCount` specifies the required number of keys to obtain from the semaphore. The default is 1.

If the specified number of keys is available, the method returns and execution continues. If the specified number of keys is not available, the process blocks until the keys become available.

The semaphore waiting queue is first-in first-out (FIFO). This does not guarantee the order in which processes arrive at the queue, only that their arrival order shall be preserved by the semaphore.

15.3.4 Try_get()

The semaphore `try_get()` method is used to procure a specified number of keys from a semaphore, but without blocking.

The prototype for `try_get()` is as follows:

```
function int try_get(int keyCount = 1);
```

The `keyCount` specifies the required number of keys to obtain from the semaphore. The default is 1.

If the specified number of keys is available, the method returns a positive integer and execution continues. If the specified number of keys is not available, the method returns 0.

15.4 Mailboxes

A mailbox is a communication mechanism that allows messages to be exchanged between processes. Data can be sent to a mailbox by one process and retrieved by another.

Conceptually, mailboxes behave like real mailboxes. When a letter is delivered and put into the mailbox, a person can retrieve the letter (and any data stored within). However, if the letter has not been delivered when a person checks the mailbox, he must choose whether to wait for the letter or to retrieve the letter on a subsequent trip to the mailbox. Similarly, SystemVerilog's mailboxes provide processes to transfer and retrieve data in a controlled manner. Mailboxes are created as having either a bounded or unbounded queue size. A bounded mailbox becomes full when it contains the bounded number of messages. A process that attempts to place a message into a full mailbox shall be suspended until enough room becomes available in the mailbox queue. Unbounded mailboxes never suspend a thread in a send operation.

An example of creating a mailbox is as follows:

```
mailbox mbxRcv;
```

Mailbox is a built-in class that provides the following methods:

- Create a mailbox: `new()`
- Place a message in a mailbox: `put()`
- Try to place a message in a mailbox without blocking: `try_put()`
- Retrieve a message from a mailbox: `get()` or `peek()`
- Try to retrieve a message from a mailbox without blocking: `try_get()` or `try_peek()`
- Retrieve the number of messages in the mailbox: `num()`

15.4.1 New()

Mailboxes are created with the `new()` method.

The prototype for mailbox `new()` is as follows:

```
function new(int bound = 0);
```

The `new()` function returns the mailbox handle. If the `bound` argument is 0, then the mailbox is unbounded (the default) and a `put()` operation shall never block. If `bound` is nonzero, it represents the size of the mailbox queue.

The bound shall be positive. Negative bounds are illegal and can result in indeterminate behavior, but implementations can issue a warning.

15.4.2 Num()

The number of messages in a mailbox can be obtained via the `num()` method.

The prototype for `num()` is as follows:

```
function int num();
```

The `num()` method returns the number of messages currently in the mailbox.

The returned value should be used with care because it is valid only until the next `get()` or `put()` is executed on the mailbox. These mailbox operations can be from different processes from the one executing the `num()` method. Therefore, the validity of the returned value depends on the time that the other methods start and finish.

15.4.3 Put()

The `put()` method places a message in a mailbox.

The prototype for `put()` is as follows:

```
task put( singular message );
```

The `message` is any singular expression, including object handles.

The `put()` method stores a message in the mailbox in strict FIFO order. If the mailbox was created with a bounded queue, the process shall be suspended until there is enough room in the queue.

15.4.4 Try_put()

The `try_put()` method attempts to place a message in a mailbox.

The prototype for `try_put()` is as follows:

```
function int try_put( singular message );
```

The `message` is any singular expression, including object handles.

The `try_put()` method stores a message in the mailbox in strict FIFO order. This method is meaningful only for bounded mailboxes. If the mailbox is not full, then the specified message is placed in the mailbox, and the function returns a positive integer. If the mailbox is full, the method returns 0.

15.4.5 Get()

The `get()` method retrieves a message from a mailbox.

The prototype for `get()` is as follows:

```
task get( ref singular message );
```

The `message` can be any singular expression, and it shall be a valid left-hand expression.

The `get()` method retrieves one message from the mailbox, that is, removes one message from the mailbox queue. If the mailbox is empty, then the current process blocks until a message is placed in the mailbox. If the type of the `message` variable is not equivalent to the type of the message in the mailbox, a run-time error is generated.

Nonparameterized mailboxes are typeless (see [15.4.9](#)), that is, a single mailbox can send and receive different types of data. Thus, in addition to the data being sent (i.e., the message queue), a mailbox implementation shall maintain the message data type placed by `put()`. This is required in order to enable the run-time type checking.

The mailbox waiting queue is FIFO. This does not guarantee the order in which processes arrive at the queue, only that their arrival order shall be preserved by the mailbox.

15.4.6 Try_get()

The `try_get()` method attempts to retrieve a message from a mailbox without blocking.

The prototype for `try_get()` is as follows:

```
function int try_get( ref singular message );
```

The `message` can be any singular expression, and it shall be a valid left-hand expression.

The `try_get()` method tries to retrieve one message from the mailbox. If the mailbox is empty, then the method returns 0. If the type of the `message` variable is not equivalent to the type of the message in the mailbox, the method returns a negative integer. If a message is available and the message type is equivalent to the type of the `message` variable, the message is retrieved, and the method returns a positive integer.

15.4.7 Peek()

The `peek()` method copies a message from a mailbox without removing the message from the queue.

The prototype for `peek()` is as follows:

```
task peek( ref singular message );
```

The `message` can be any singular expression, and it shall be a valid left-hand expression.

The `peek()` method copies one message from the mailbox without removing the message from the mailbox queue. If the mailbox is empty, then the current process blocks until a message is placed in the mailbox. If the type of the `message` variable is not equivalent to the type of the message in the mailbox, a run-time error is generated.

Calling the `peek()` method can also cause one message to unblock more than one process. As long as a message remains in the mailbox queue, any process blocked in either a `peek()` or `get()` operation shall become unblocked.

15.4.8 Try_peek()

The `try_peek()` method attempts to copy a message from a mailbox without blocking.

The prototype for `try_peek()` is as follows:

```
function int try_peek( ref singular message );
```

The `message` can be any singular expression, and it shall be a valid left-hand expression.

The `try_peek()` method tries to copy one message from the mailbox without removing the message from the mailbox queue. If the mailbox is empty, then the method returns 0. If the type of the `message` variable is not equivalent to the type of the message in the mailbox, the method returns a negative integer. If a message is available and its type is equivalent to the type of the message variable, the message is copied, and the method returns a positive integer.

15.4.9 Parameterized mailboxes

The default mailbox is typeless, that is, a single mailbox can send and receive any type of data. This is a very powerful mechanism, which, unfortunately, can also result in run-time errors due to type mismatches (types not equivalent) between a message and the type of the variable used to retrieve the message. Frequently, a mailbox is used to transfer a particular message type, and, in that case, it is useful to detect type mismatches at compile time.

Parameterized mailboxes use the same parameter mechanism as parameterized classes (see [8.24](#)), modules, and interfaces:

```
mailbox #(type = dynamic_type)
```

where `dynamic_type` represents a special type that enables run-time type checking (the default).

A parameterized mailbox of a specific type is declared by specifying the type:

```
typedef mailbox #(string) s_mbox;  
  
s_mbox sm = new;  
string s;  
  
sm.put( "hello" );  
...  
sm.get( s ); // s <- "hello"
```

Parameterized mailboxes provide all the same standard methods as dynamic mailboxes: `num()`, `new()`, `get()`, `peek()`, `put()`, `try_get()`, `try_peek()`, `try_put()`.

The only difference between a generic (dynamic) mailbox and a parameterized mailbox is that for a parameterized mailbox, the compiler verifies that the calls to `put`, `try_put`, `peek`, `try_peek`, `get`, and `try_get` methods use argument types equivalent to the mailbox type so that all type mismatches are caught by the compiler and not at run time.

15.5 Named events

An identifier declared as an event data type is called a *named event*. A named event can be triggered explicitly. It can be used in an event expression to control the execution of procedural statements in the same manner as event controls described in [9.4.2](#). A named event may also be used as a handle assigned from another named event.

A named event provides a handle to an underlying synchronization object. When a process waits for an event to be triggered, the process is put on a queue maintained within the synchronization object. Processes can wait for a named event to be triggered either via the `@` operator or by the use of the `wait()` construct to examine their triggered state.

15.5.1 Triggering an event

An event is made to occur by the activation of an event triggering statement with the syntax given in [Syntax 15-1](#).

```

event_trigger ::= // from A.6.5
    -> hierarchical_event_identifier ;
    | ->> [ delay_or_event_control ] hierarchical_event_identifier ;

```

Syntax 15-1—Event trigger syntax (excerpt from [Annex A](#))

An event is not made to occur by changing the index of a named event array in an event control expression.

Named events triggered via the `->` operator unblock all processes currently waiting on that event. When triggered, named events behave like a one shot, i.e., the trigger state itself is not observable, only its effect. This is similar to the way in which an edge can trigger a flip-flop, but the state of the edge cannot be ascertained, i.e., if `(posedge clock)` is illegal.

Nonblocking events are triggered using the `->>` operator. The effect of the `->>` operator is that the statement executes without blocking and it creates a nonblocking assign update event in the time in which the delay control expires or the event control occurs. The effect of this update event shall be to trigger the referenced event in the nonblocking assignment region of the simulation cycle.

15.5.2 Waiting for an event

The basic mechanism to wait for an event to be triggered is via the event control operator, `@`.

```
@ hierarchical_event_identifier;
```

The `@` operator blocks the calling process until the given event is triggered.

For a trigger to unblock a process waiting on an event, the waiting process shall execute the `@` statement before the triggering process executes the trigger operator, `->`. If the trigger executes first, then the waiting process remains blocked.

15.5.3 Persistent trigger: triggered property

SystemVerilog can distinguish the event trigger itself, which is instantaneous, from the event's triggered state, which persists throughout the time step (i.e., until simulation time advances). The `triggered` event property allows users to examine this state.

The `triggered` property is invoked using a method-like syntax:

```
hierarchical_event_identifier.triggered
```

The `triggered` event property evaluates to true if the given event has been triggered in the current time step and false otherwise. If `event_identifier` is `null`, then the `triggered` event property evaluates to false.

The `triggered` event property is most useful when used in the context of a `wait` construct:

```
wait ( hierarchical_event_identifier.triggered )
```

Using this mechanism, an event trigger shall unblock the waiting process whether the `wait` executes before or at the same simulation time as the trigger operation. The `triggered` event property, thus, helps eliminate a common race condition that occurs when both the trigger and the `wait` happen at the same time. A process that blocks waiting for an event might or might not unblock, depending on the execution order of the waiting

and triggering processes. However, a process that waits on the triggered state always unblocks, regardless of the order of execution of the wait and trigger operations.

Example:

```
event done, blast;           // declare two new events
event done_too = done;       // declare done_too as alias to done

task trigger( event ev );
    -> ev;
endtask

...

fork
    @ done_too;               // wait for done through done_too
    #1 trigger( done );      // trigger done through task trigger
join

fork
    -> blast;
    wait ( blast.triggered );
join
```

The first fork in the example shows how two event identifiers, `done` and `done_too`, refer to the same synchronization object and also how an event can be passed to a generic task that triggers the event. In the example, one process waits for the event via `done_too`, while the actual triggering is done via the `trigger` task that is passed `done` as an argument.

In the second fork, one process can trigger the event `blast` before the other process (if the processes in the `fork...join` execute in source order) has a chance to execute, and wait for the event. Nonetheless, the second process unblocks and the fork terminates. This is because the process waits for the event's triggered state, which remains in its triggered state for the duration of the time step.

15.5.4 Event sequencing: `wait_order()`

The `wait_order` construct suspends the calling process until all of the specified events are triggered in the given order (left to right) or any of the untriggered events are triggered out of order and thus causes the operation to fail.

The syntax for the `wait_order` construct is as follows in [Syntax 15-2](#).

```
wait_statement ::= //from A.6.5
    ...
    | wait_order ( hierarchical_identifier { , hierarchical_identifier } ) action_block
action_block ::=
    statement_or_null
    | [ statement ] else statement
```

Syntax 15-2—Wait_order event sequencing syntax (excerpt from [Annex A](#))

For `wait_order` to succeed, at any point in the sequence, the subsequent events, which shall all be untriggered at this point or the sequence would have already failed, shall be triggered in the prescribed order.

Preceding events are not limited to occur only once. In other words, once an event occurs in the prescribed order, it can be triggered again without causing the construct to fail.

Only the first event in the list can wait for the persistent `triggered` property.

The action taken when the construct fails depends on whether the optional `action_block else` statement (the fail statement) is specified. If it is specified, then the given statement is executed upon failure of the construct. If the fail statement is not specified, a failure generates a run-time error.

For example:

```
wait_order( a, b, c );
```

suspends the current process until events `a`, `b`, and `c` trigger in the order `a -> b -> c`. If the events trigger out of order, a run-time error is generated.

For example:

```
wait_order( a, b, c ) else $display( "Error: events out of order" );
```

In this example, the fail statement specifies that, upon failure of the construct, a user message be displayed, but without an error being generated.

For example:

```
bit success;  
wait_order( a, b, c ) success = 1; else success = 0;
```

In this example, the completion status is stored in the variable `success`, without an error being generated.

15.5.5 Operations on named event variables

An event is a unique data type with several important properties. Named events can be assigned to one another. When one event is assigned to another, the synchronization queue of the source event is shared by both the source and the destination event. In this sense, events act as full-fledged variables and not merely as labels.

15.5.5.1 Merging events

When one event variable is assigned to another, the two become merged. Thus, executing `->` on either event variable affects processes waiting on either event variable.

For example:

```
event a, b, c;  
a = b;  
-> c;  
-> a;    // also triggers b  
-> b;    // also triggers a  
a = c;  
b = a;  
-> a;    // also triggers b and c  
-> b;    // also triggers a and c  
-> c;    // also triggers a and b
```

When events are merged, the assignment only affects the execution of subsequent event control or wait operations. If a process is blocked waiting for `event1` when another event is assigned to `event1`, the currently waiting process shall never unblock. For example:

```
fork
  T1: forever @ E2;
  T2: forever @ E1;
  T3: begin
      E2 = E1;
      forever -> E2;
  end
join
```

This example forks off three concurrent processes. Each process starts at the same time. Thus, at the same time that processes `T1` and `T2` are blocked, process `T3` assigns event `E1` to `E2`. As a result, process `T1` shall never unblock because the event `E2` is now `E1`. To unblock both threads `T1` and `T2`, the merger of `E2` and `E1` must take place before the fork.

15.5.5.2 Reclaiming events

When an event variable is assigned the special `null` value, the association between the event variable and the underlying synchronization queue is broken. When no event variable is associated with an underlying synchronization queue, the resources of the queue itself become available for reuse.

Triggering a `null` event shall have no effect. The outcome of waiting on a `null` event is undefined, and implementations can issue a run-time warning.

For example:

```
event E1 = null;
@ E1;                // undefined: might block forever or not at all
wait( E1.triggered ); // undefined
-> E1;                // no effect
```

15.5.5.3 Events comparison

Event variables can be compared against other event variables or the special value `null`. Only the following operators are allowed for comparing event variables:

- Equality (`==`) with another event or with `null`
- Inequality (`!=`) with another event or with `null`
- Case equality (`===`) with another event or with `null` (same semantics as `==`)
- Case inequality (`!==`) with another event or with `null` (same semantics as `!=`)
- Test for a Boolean value that shall be 0 if the event is `null` and 1 otherwise

Example:

```
event E1, E2;
if ( E1 ) // same as if ( E1 != null )
  E1 = E2;
if ( E1 == E2 )
  $display( "E1 and E2 are the same event" );
```

16. Assertions

16.1 General

This clause describes the following:

- Immediate assertions
- Concurrent assertions
- Sequence specifications
- Property specifications

16.2 Overview

An assertion specifies a behavior of the system. Assertions are primarily used to validate the behavior of a design. In addition, assertions can be used to provide functional coverage and to flag that input stimulus, which is used for validation, does not conform to assumed requirements.

An assertion appears as an assertion statement that states the verification function to be performed. The statement shall be of one of the following kinds:

- **assert**, to specify the property as an obligation for the design that is to be checked to verify that the property holds.
- **assume**, to specify the property as an assumption for the environment. Simulators check that the property holds, while formal tools use the information to generate input stimulus.
- **cover**, to monitor the property evaluation for coverage.
- **restrict**, to specify the property as a constraint on formal verification computations. Simulators do not check the property.

There are two kinds of assertions: concurrent and immediate.

- Immediate assertions follow simulation event semantics for their execution and are executed like a statement in a procedural block. Immediate assertions are primarily intended to be used with simulation. There is no immediate **restrict** assertion statement.
- Concurrent assertions are based on clock semantics and use sampled values of variables. One of the goals of SystemVerilog assertions is to provide a common semantic meaning for assertions so that they can be used to drive various design and verification tools. Many tools, such as formal verification tools, evaluate circuit descriptions using cycle-based semantics, which typically relies on a clock signal or signals to drive the evaluation of the circuit. Any timing or event behavior between clock edges is abstracted away. Concurrent assertions incorporate this clock semantics. While this approach generally simplifies the evaluation of a circuit description, there are a number of scenarios under which this cycle-based evaluation provides different behavior from the standard event-based evaluation of SystemVerilog.

This clause describes both types of assertions.

16.3 Immediate assertions

The immediate assertion statement is a test of an expression performed when the statement is executed in the procedural code. The expression is nontemporal and is interpreted the same way as an expression in the condition of a procedural **if** statement. In other words, if the expression evaluates to x , z , or 0 , then it is interpreted as being false, and the assertion statement is said to fail. Otherwise, the expression is interpreted as being true, and the assertion statement is said to pass or, equivalently, to succeed.

There are two types of immediate assertions, *simple immediate assertions* and *deferred immediate assertions*. In a simple immediate assertion, pass and fail actions take place immediately upon assertion evaluation. In a deferred immediate assertion, the actions are delayed until later in the time step, providing some level of protection against unintended multiple executions on transient or “glitch” values. Deferred immediate assertions are described in detail in [16.4](#).

The *immediate_assertion_statement* is a *statement_item* and can be specified anywhere a procedural statement is specified. The execution of immediate assertions can be controlled by using assertion control system tasks (see [20.11](#)).

```

procedural_assertion_statement ::=                                     // from A.6.10
    ...
    | immediate_assertion_statement
    ...
immediate_assertion_statement ::=
    simple_immediate_assertion_statement
    | deferred_immediate_assertion_statement
simple_immediate_assertion_statement ::=
    simple_immediate_assert_statement
    | simple_immediate_assume_statement
    | simple_immediate_cover_statement
simple_immediate_assert_statement ::=
    assert ( expression ) action_block
simple_immediate_assume_statement ::=
    assume ( expression ) action_block
simple_immediate_cover_statement ::=
    cover ( expression ) statement_or_null
deferred_immediate_assertion_item ::= [ block_identifier : ] deferred_immediate_assertion_statement
deferred_immediate_assertion_statement ::=
    deferred_immediate_assert_statement
    | deferred_immediate_assume_statement
    | deferred_immediate_cover_statement
deferred_immediate_assert_statement ::=
    assert #0 ( expression ) action_block
deferred_immediate_assume_statement ::=
    assume #0 ( expression ) action_block
deferred_immediate_cover_statement ::=
    cover #0 ( expression ) statement_or_null
action_block ::=                                                 // from A.6.3
    statement_or_null
    | [ statement ] else statement_or_null

```

Syntax 16-1—Immediate assertion syntax (excerpt from [Annex A](#))

There are three types of immediate assertions: immediate **assert**, immediate **assume**, and immediate **cover**.

The immediate **assert** statement specifies that its expression is required to hold. Failure of an immediate **assert** statement indicates a violation of the requirement and thus a potential error in the design. If an

assert statement fails and no **else** clause is specified, the tool shall, by default, call `$error`, unless `$assertfailoff` is used to suppress the failure.

The immediate **assume** statement specifies that its expression is assumed to hold. For example, immediate **assume** statements can be used with formal verification tools to specify assumptions on design inputs that constrain the verification computation. When used in this way, they specify the expected behavior of the environment of the design as opposed to that of the design itself. In simulation, an immediate **assume** may behave as an immediate **assert** to verify that the environment behaves as assumed. A simulation tool shall provide the capability to check the immediate **assume** statement in this way.

The *action_block* of an immediate **assert** or **assume** statement specifies what actions are taken upon success or failure of the assertion. The statement associated with success is the first statement. It is called the *pass statement* and shall be executed if the *expression* evaluates to true. The pass statement can, for example, record the number of successes for a coverage log, but can be omitted altogether. If the pass statement is omitted, then no user-specified action is taken when the *assert expression* of the immediate **assert** or **assume** statement is true. The statement associated with **else** is called the *fail statement* and shall be executed if the *expression* evaluates to false. The **else** statement can also be omitted. The action block shall be enabled to execute immediately after the evaluation of the *assert expression* of the immediate **assert** or **assume** statement. The execution of pass and fail statements can be controlled by using assertion action control tasks. The assertion action control tasks are described in [20.12](#).

The immediate **cover** statement specifies that successful evaluation of its *expression* is a coverage goal. Tools shall collect coverage information and report the results at the end of simulation or on demand via an assertion API (see [Clause 39](#)). The results of coverage for an immediate **cover** statement shall contain the following:

- Number of times evaluated
- Number of times succeeded

A pass statement for an immediate **cover** may be specified in *statement_or_null*. The pass statement shall be executed if the expression evaluates to true. The pass statement shall be enabled to execute immediately after the evaluation of the expression of the immediate **cover**.

The optional statement label (identifier and colon) creates a named block around the assertion statement (or any other statement) and the hierarchical name of the scope can be displayed using the `%m` format specification.

The information about assertion failure can be printed using one of the following severity system tasks in the action block:

- `$fatal` is a run-time fatal.
- `$error` is a run-time error.
- `$warning` is a run-time warning.
- `$info` indicates that the assertion failure carries no specific severity.

The syntax for these severity system tasks is shown in [20.9](#).

The severity system tasks can be used in assertion pass or fail statements. These tasks shall print the same tool-specific message when used either in a pass or a fail statement. For example:

```
assert_f: assert(f) $info("passed"); else $error("failed");

assume_inputs: assume (in_a || in_b) $info("assumption holds");
else $error("assumption does not hold");
```

```
cover_a_and_b: cover (in_a && in_b) $info("in_a && in_b == 1 covered");
```

For example, a formal verification tool might prove `assert_f` under the assumption `assume_inputs` expressing the condition that `in_a` and `in_b` are not both 0 at the same time. The `cover` statement detects whether `in_a` and `in_b` are both simultaneously 1.

If more than one of these system tasks is included in the action block, then each shall be executed as specified.

If the severity system task is executed at a time other than when the immediate `assert` or `assume` fails, the actual failure time of the immediate `assert` or `assume` can be recorded and displayed programmatically. For example:

```
time t;

always @(posedge clk)
  if (state == REQ)
    assert (req1 || req2)
    else begin
      t = $time;
      #5 $error("assert failed at time %0t",t);
    end
```

If the immediate `assert` fails at time 10, the error message shall be printed at time 15, but the user-defined string printed will be “assert failed at time 10”.

Because the fail statement, like the pass statement, is any legal SystemVerilog procedural statement, it can also be used to signal a failure to another part of the testbench.

```
assert (myfunc(a,b)) count1 = count + 1; else ->event1;
assert (y == 0) else flag = 1;
```

16.4 Deferred assertions

```
immediate_assertion_statement ::= //from A.6.10
...
| deferred_immediate_assertion_statement
deferred_immediate_assertion_item ::= [ block_identifier : ] deferred_immediate_assertion_statement
deferred_immediate_assertion_statement ::=
  deferred_immediate_assert_statement
  | deferred_immediate_assume_statement
  | deferred_immediate_cover_statement
deferred_immediate_assert_statement ::=
  assert #0 ( expression ) action_block
deferred_immediate_assume_statement ::=
  assume #0 ( expression ) action_block
deferred_immediate_cover_statement ::=
  cover #0 ( expression ) statement_or_null
```

Syntax 16-2—Deferred immediate assertion syntax (excerpt from [Annex A](#))

Deferred assertions are a kind of immediate assertion. They can be used to suppress false reports that occur due to glitching activity on combinational inputs to immediate assertions. Since deferred assertions are a subset of immediate assertions, the term *deferred assertion* (often used for brevity) is equivalent to the term *deferred immediate assertion*. The term *simple immediate assertion* refers to an immediate assertion that is not deferred.

A deferred assertion is similar to a simple immediate assertion, but with the following key differences:

- Syntax: Deferred assertions use #0 after the verification directive.
- Deferral: Reporting is delayed rather than being reported immediately.
- Action block limitations: Action blocks may only contain a single subroutine call.
- Use outside procedures: A deferred assertion may be used as a *module_common_item*.

Deferred assertion syntax is similar to simple immediate assertion syntax, with the difference being the specification of a #0 delay control after the keyword:

```
assert #0 (expression) action_block
```

As with all immediate assertions, a deferred assertion's *expression* is evaluated at the time the deferred assertion statement is processed. However, in order to facilitate glitch avoidance, the reporting or action blocks are scheduled at a later point in the current time step.

The pass and fail statements in a deferred assertion's *action_block*, if present, shall each consist of a single subroutine call. The subroutine can be a task, task method, void function, void function method, or system task. The subroutine shall be scheduled in the Reactive region. A subroutine argument may be passed by value as an input or passed by reference as a **ref** or **const ref**. Actual argument expressions that are passed by value use the values of the underlying variables at the instant the deferred assertion expression was evaluated. Actual argument expressions that are passed by reference use or assign the current values of the underlying variables in the Reactive region. It shall be an error to pass automatic or dynamic variables as actuals to a **ref** or **const ref** formal. The requirement of a single subroutine call implies that no begin-end construct shall surround the pass or fail statements, as **begin** is itself a statement which is not a subroutine call.

Deferred assertions may also be used outside procedural code, as a *module_common_item*. This is explained in more detail in [16.4.3](#).

In addition to deferred **assert** statements, deferred **assume** and **cover** statements are also defined. Other than the deferred evaluation as described in this section, these **assume** and **cover** statements behave the same way as the simple immediate **assume** and **cover** statements described in [16.3](#). A deferred **assume** will often be useful in cases where a combinational condition is checked in a function, but needs to be used as an assumption rather than a proof target by formal tools. A deferred **cover** is useful to avoid crediting tests for covering a condition that is only met in passing by glitched values.

16.4.1 Deferred assertion reporting

When a deferred assertion declared with **assert** #0 passes or fails, the action block is not executed immediately. Instead, the action block subroutine call (or `$error`, if an **assert** or **assume** fails and no *action_block* is present) and the current values of its input arguments are placed in a *deferred assertion report queue* associated with the currently executing process. Such a call is said to be a *pending assertion report*.

If a *deferred assertion flush point* (see [16.4.2](#)) is reached in a process, its deferred assertion report queue is cleared. Any pending assertion reports will not be executed.

In the Observed region of each simulation time step, each pending assertion report that has not been flushed from its queue shall *mature*, or be confirmed for reporting. Once a report matures, it may no longer be flushed. Then the associated subroutine call (or `$error`, if the assertion fails and no action block is present) is executed in the Reactive region, and the pending assertion report is cleared from the appropriate process's deferred assertion report queue.

Note that if code in the Reactive region modifies signals and causes another pass to the Active region to occur, this still may create glitching behavior, as the new passage in the Active region may re-execute some of the deferred assertions with different reported results. In general, deferred assertions prevent glitches due to order of procedural execution, but do not prevent glitches caused by execution loops between regions that the assignments from the Reactive region may cause.

16.4.2 Deferred assertion flush points

A process is defined to have reached a deferred assertion flush point if any of the following occur:

- The process, having been suspended earlier due to reaching an event control or wait statement, resumes execution.
- The process was declared by an `always_comb` or `always_latch`, and its execution is resumed due to a transition on one of its dependent signals.
- The outermost scope of the process is disabled by a `disable` statement (see [16.4.4](#))

The following example shows how deferred assertions might be used to avoid undesired reports of a failure due to transitional combinational values in a single simulation time step:

```
assign not_a = !a;
always_comb begin : b1
  a1: assert (not_a != a);
  a2: assert #0 (not_a != a); // Should pass once values have settled
end
```

When `a` changes, a simulator could evaluate assertions `a1` and `a2` twice—once for the change in `a` and once for the change in `not_a` after the evaluation of the continuous assignment. A failure could thus be reported during the first execution of `a1`. The failure during the first execution of `a2` will be scheduled on the process's deferred assertion report queue. When `not_a` changes, the deferred assertion queue is flushed due to the activation of `b1`, so no failure of `a2` will be reported.

This example illustrates the behavior of deferred assertions in the presence of time delays:

```
always @(a or b) begin : b1
  a3: assert #0 (a == b) rptobj.success(0) else rptobj.error(0, a, b);
  #1;
  a4: assert #0 (a == b) rptobj.success(1) else rptobj.error(1, a, b);
end
```

In this case, due to the time delay in the middle of the procedure, an Observed region will always be reached after the execution of `a3` and before a flush point. Thus any passes or failures of `a3` will always be reported. For `a4`, during cycles where either `a` or `b` changes after it has been executed, failures will be flushed and never reported. In general, deferred assertions must be used carefully when mixed with time delays.

The following example illustrates a typical use of a deferred `cover` statement:

```
assign a = ...;
assign b = ...;
always_comb begin : b1
```

```

    c1: cover (b != a);
    c2: cover #0 (b != a);
end

```

In this example, it is important to make sure some test is covering the case where *a* and *b* have different values. Due to the arbitrary order of the assignments in the simulator, it might be the case that in a cycle where both variables are being assigned the same value, *b1* executes while *a* has been assigned but *b* still holds its previous value. Thus *c1* will be triggered, but this is actually a glitch, and probably not a useful piece of coverage information. In the case of *c2*, this coverage will get added to the deferred report queue, but when *b1* is executed the next time (after *b* has also been assigned its new value), that coverage point will be flushed, and *c2* will correctly not get reported as having been covered during that time step.

16.4.3 Deferred assertions outside procedural code

A deferred assertion statement may also appear outside procedural code, used as a *module_common_item*. In such cases, it is treated as if it were contained in an **always_comb** procedure. For example:

```

module m (input a, b);
    a1: assert #0 (a == b);
endmodule

```

This is equivalent to the following:

```

module m (input a, b);
    always_comb begin
        a1: assert #0 (a == b);
    end
endmodule

```

16.4.4 Disabling deferred assertions

The **disable** statement shall interact with deferred assertions as follows:

- A specific deferred assertion may be disabled. Any pending assertion reports for that assertion are cancelled.
- When a **disable** is applied to the outermost scope of a procedure that has an active deferred assertion queue, in addition to normal disable activities (see [9.6.2](#)), the deferred assertion report queue is flushed and all pending assertion reports on the queue are cleared.

Disabling a task or a non-outermost scope of a procedure does not cause flushing of any pending reports.

The following example illustrates how user code can explicitly flush a pending assertion report. In this case, failures of *a1* are only reported in time steps where *bad_val_ok* does not settle at a value of 1.

```

always @(bad_val or bad_val_ok) begin : b1
    a1: assert #0 (bad_val) else $fatal("Sorry");
    if (bad_val_ok) begin
        disable a1;
    end
end

```

The following example illustrates how user code can explicitly flush all pending assertion reports on the deferred assertion queue of process *b2*:

```

always @(a or b or c) begin : b2
    if (c == 8'hff) begin

```

```
        a2: assert #0 (a && b);  
    end else begin  
        a3: assert #0 (a || b);  
    end  
end  
  
    always @(clear_b2) begin : b3  
        disable b2;  
    end
```

16.4.5 Deferred assertions and multiple processes

As described in the above subclauses, deferred assertions are inherently associated with the process in which they are executed. This means that a deferred assertion within a function may be executed several times due to the function being called by several different processes, and each of these different process executions is independent. The following example illustrates this situation:

```
module fsm(...);  
    function bit f (int a, int b)  
        ...  
        a1: assert #0 (a == b);  
        ...  
    endfunction  
    ...  
    always_comb begin : b1  
        some_stuff = f(x,y) ? ...  
        ...  
    end  
    always_comb begin : b2  
        other_stuff = f(z,w) ? ...  
        ...  
    end  
endmodule
```

In this case, there are two different processes which may call assertion a1: b1 and b2. Suppose simulation executes the following scenario in the first passage through the Active region of each time step:

- In time step 1, b1 executes with $x \neq y$, and b2 executes with $z \neq w$.
- In time step 2, b1 executes with $x \neq y$, then again with $x = y$.
- In time step 3, b1 executes with $x \neq y$, then b2 executes with $z = w$.

In the first time step, since a1 fails independently for processes b1 and b2, its failure is reported twice.

In the second time step, the failure of a1 in process b1 is flushed when the process is re-triggered, and since the final execution passes, no failure is reported.

In the third time step, the failure in process b1 does not see a flush point, so that failure is reported. In process b2, the assertion passes, so no failure is reported from that process.

16.5 Concurrent assertions overview

Concurrent assertions describe behavior that spans over time. Unlike immediate assertions, the evaluation model is based on a clock so that a concurrent assertion is evaluated only at the occurrence of a clock tick.

All variables in a concurrent assertion use the value sampled in the Preponed region of a time slot with the exception of local variables, constant casts and automatic variables in procedural code (see [16.15.6](#)), and

free checker variables (see [17.7.2](#)). The assertions are evaluated during the Observed region. If a variable used in an assertion is a **clocking** block input variable, the variable shall be sampled by the **clocking** block with `#1step` sampling. Any other type of sampling for the **clocking** block variable shall result in an error. The assertion using the **clocking** block variable shall not do its own sampling on the variable, but rather use the sampled value produced by the **clocking** block. This is explained in [Clause 14](#).

The timing model employed in a concurrent assertion specification is based on clock ticks and uses a generalized notion of clock cycles. The definition of a clock is explicitly specified by the user and can vary from one expression to another.

A *clock tick* is an atomic moment in time that itself spans no duration of time. A clock shall tick only once at any simulation time, and the sampled values for that simulation time are used for evaluation of concurrent assertions. In an assertion, the sampled value is the only valid value of a variable at a clock tick. [Figure 16-1](#) shows the values of a variable as the clock progresses. The value of signal `req` is low at clock ticks 1 and 2. At clock tick 3, the value is sampled as high and remains high until clock tick 6. The sampled value of variable `req` at clock tick 6 is low and remains low up to and including clock tick 9. Notice that the simulation value transitions to high at clock tick 9. However, the sampled value at clock tick 9 is low.

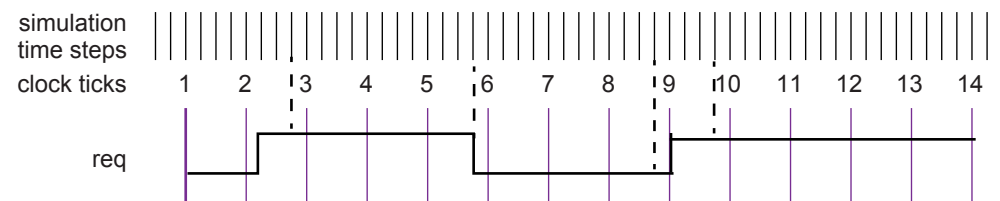

Figure 16-1—Sampling a variable in a simulation time step

An expression used in an assertion is always tied to a clock definition, except for the use of constant or automatic values from procedural code (see [16.15.6](#)) and free checker variables (see [17.7.2](#)). The sampled values are used to evaluate value change expressions or Boolean subexpressions that are required to determine a match of a sequence.

For concurrent assertions, the following statements apply:

- It is important that the defined clock behavior be glitch free. Otherwise, wrong values can be sampled.
- If a variable that appears in the expression for clock also appears in an expression with an assertion, the values of the two usages of the variable can be different. The current value of the variable is used in the clock expression, while the sampled value of the variable is used within the assertion.

The clock expression that controls evaluation of a sequence can be more complex than just a single signal name. Expressions such as `(clk && gating_signal)` and `(clk iff gating_signal)` can be used to represent a gated clock. Other more complex expressions are possible. However, in order to verify proper behavior of the system and conform as closely as possible to truly cycle-based semantics, the user should ensure that the clock expression is glitch-free and only transitions once at any simulation time.

A reference to `$global_clock` (see [14.14](#)) is understood to be a reference to the *clocking_event* defined in the **global clocking** declaration. The global clock behaves just as any other clocking event. In formal verification, however, `$global_clock` has additional significance, as it is considered to be the primary system clock (see [F.5.1](#)). Thus, in the following example:

```
global clocking @clk; endclocking
...
assert property (@$global_clock a);
```

the assertion states that `a` is true at each tick of the global clock. This assertion is logically equivalent to:

```
assert property (@clk a);
```

An example of a concurrent assertion is as follows:

```
base_rule1: assert property (cont_prop(rst,in1,in2)) $display("%m, passing");  
           else $display("%m, failed");
```

The keyword **property** distinguishes a concurrent assertion from an immediate assertion. The syntax of concurrent assertions is discussed in [16.15](#).

16.6 Boolean expressions

The outcome of the evaluation of an expression is Boolean and is interpreted the same way as an expression is interpreted in the condition of a procedural **if** statement. In other words, if the expression evaluates to `x`, `z`, or `0`, then it is interpreted as being false. Otherwise, it is true.

There are certain restrictions on the expressions that can appear in concurrent assertions. The restrictions on operand types, variables, and operators are specified in [16.6.1](#), [16.6.2](#), and [16.6.3](#).

Expressions are allowed to include function calls, but the following semantic restrictions are imposed:

- Functions that appear in expressions shall not contain output or **ref** arguments (**const ref** is allowed).
- Functions shall be automatic (or preserve no state information) and have no side effects.

There are two places where Boolean expressions occur in concurrent assertions. They are as follows:

- In a sequence or property expression
- In the disable condition inferred for an assertion, specified either in a top-level **disable iff** clause (see [16.13](#)) or in a default **disable iff** declaration (see [16.16](#))

The Boolean expressions used in defining a sequence or property expression shall be evaluated over the sampled values of all variables (other than local variables as described in [16.10](#)) and the current values of local variables and of the sequence Boolean methods `triggered` and `matched` (see [16.14.6](#)). The preceding rule shall not, however, apply to expressions in a clocking event (see [16.5](#)).

The expressions in a disable condition are evaluated using the current values of variables (not sampled) and may contain the sequence Boolean method `triggered`. They shall not contain any reference to local variables or to the sequence method `matched`. If a sampled value function other than `$sampled` (see [16.9.3](#)) is used in an expression in a disable condition, the sampling clock shall be explicitly specified in the actual argument list. For example:

```
assert property ( @(posedge clk)  
                disable iff (a && $rose(b, @(posedge clk))) trigger | => test_expr );
```

The disable condition specified in the **disable iff** clause will preempt the evaluation of the assertion in a time step where `a` is 1 and the sampled value function returns a 1 as determined by the rules of evaluation for use outside sequences described in [16.9.3](#).

16.6.1 Operand types

The following types are not allowed:

- Noninteger types (**shortreal**, **real**, and **realtime**)

- `string`
- `event`
- `chandle`
- `class`
- Associative arrays
- Dynamic arrays

Fixed-size arrays, packed or unpacked, can be used as a whole or as part-selects or as indexed bit-selects or part-selects. The indices can be constants, parameters, or variables.

The following example shows some possible forms of comparison of members of structures and unions:

```
typedef int array [4];
typedef struct {int a, b, c, d;} record;
union { record r; array a; } p, q;
```

The following comparisons are legal in expressions:

```
p.a == q.a
```

and

```
p.r == q.r
```

The following example provides further illustration of the use of arrays in expressions:

```
logic [7:0] arrayA [16], arrayB[16];
```

The following comparisons are legal:

```
arrayA == arrayB
arrayA != arrayB
arrayA[i] >= arrayB[j]
arrayB[i][j+:2] == arrayA[k][m-:2]
(arrayA[i] & (~arrayB[j])) == 0
```

16.6.2 Variables

The variables that can appear in expressions shall be static design variables, function calls returning values of types described in [16.6.1](#), or local variables. Static variables declared in programs, interfaces, or `clocking` blocks can also be accessed. If a reference is to a static variable declared in a task, that variable is sampled as any other variable, independent of calls to the task.

16.6.3 Operators

All operators that are valid for the types described in [16.6.1](#) are allowed with the exception of assignment operators and increment and decrement operators. SystemVerilog includes the C assignment operators, such as `+=`, and the C increment and decrement operators, `++` and `--`. These operators cannot be used in expressions that appear in assertions. This restriction prevents side effects.

16.7 Sequences

```

sequence_expr ::=
    cycle_delay_range sequence_expr { cycle_delay_range sequence_expr }
  | sequence_expr cycle_delay_range sequence_expr { cycle_delay_range sequence_expr }
  | expression_or_dist [ boolean_abbrev ]
  | sequence_instance [ sequence_abbrev ]
  | ( sequence_expr { , sequence_match_item } ) [ sequence_abbrev ]
  | sequence_expr and sequence_expr
  | sequence_expr intersect sequence_expr
  | sequence_expr or sequence_expr
  | first_match ( sequence_expr { , sequence_match_item } )
  | expression_or_dist throughout sequence_expr
  | sequence_expr within sequence_expr
  | clocking_event sequence_expr

cycle_delay_range ::=
    ## constant_primary
  | ## [ cycle_delay_const_range_expression ]
  | ## [*]
  | ## [+]

sequence_match_item ::=
    operator_assignment
  | inc_or_dec_expression
  | subroutine_call

sequence_instance ::=
    ps_or_hierarchical_sequence_identifier [ ( [ sequence_list_of_arguments ] ) ]

sequence_list_of_arguments ::=
    [sequence_actual_arg] { , [sequence_actual_arg] } { , . identifier ( [sequence_actual_arg] ) }
  | . identifier ( [sequence_actual_arg] ) { , . identifier ( [sequence_actual_arg] ) }

sequence_actual_arg ::=
    event_expression
  | sequence_expr

boolean_abbrev ::=
    consecutive_repetition
  | non_consecutive_repetition
  | goto_repetition

sequence_abbrev ::= consecutive_repetition
consecutive_repetition ::=
    [* const_or_range_expression ]
  | [*]
  | [+]

non_consecutive_repetition ::= [= const_or_range_expression ]
goto_repetition ::= [-> const_or_range_expression ]

const_or_range_expression ::=
    constant_expression
  | cycle_delay_const_range_expression

cycle_delay_const_range_expression ::=
    constant_expression : constant_expression
  | constant_expression : $

expression_or_dist ::= expression [ dist { dist_list } ]

```

Syntax 16-3—Sequence syntax (excerpt from [Annex A](#))

Properties are often constructed out of sequential behaviors. The **sequence** feature provides the capability to build and manipulate sequential behaviors. The simplest sequential behaviors are linear. A linear sequence is a finite list of SystemVerilog Boolean expressions in a linear order of increasing time. The linear sequence is said to match along a finite interval of consecutive clock ticks provided the first Boolean expression evaluates to true at the first clock tick, the second Boolean expression evaluates to true at the second clock tick, and so forth, up to and including the last Boolean expression evaluating to true at the last clock tick. A single Boolean expression is an example of a simple linear sequence, and it matches at a single clock tick provided the Boolean expression evaluates to true at that clock tick.

More complex sequential behaviors are described by SystemVerilog sequences. A sequence is a regular expression over the SystemVerilog Boolean expressions that concisely specifies a set of zero, finitely many, or infinitely many linear sequences. If at least one of the linear sequences from this set matches along a finite interval of consecutive clock ticks, then the sequence is said to match along that interval.

A property may involve checking of one or more sequential behaviors beginning at various times. An attempted evaluation of a sequence is a search for a match of the sequence beginning at a particular clock tick. To determine whether such a match exists, appropriate Boolean expressions are evaluated beginning at the particular clock tick and continuing at each successive clock tick until either a match is found or it is deduced that no match can exist.

Sequences can be composed by concatenation, analogous to a concatenation of lists. The concatenation specifies a delay, using ##, from the end of the first sequence until the beginning of the second sequence.

The syntax for sequence concatenation is shown in [Syntax 16-4](#).

```
sequence_expr ::= // from A.2.10
    cycle_delay_range sequence_expr { cycle_delay_range sequence_expr }
    | sequence_expr cycle_delay_range sequence_expr { cycle_delay_range sequence_expr }
    ...
cycle_delay_range ::=
    ## constant_primary
    | ## [ cycle_delay_const_range_expression ]
    | ## [*]
    | ## [+]
cycle_delay_const_range_expression ::=
    constant_expression : constant_expression
    | constant_expression : $
```

Syntax 16-4—Sequence concatenation syntax (excerpt from [Annex A](#))

In this syntax, the following statements apply:

- *constant_primary* includes *constant_expression* which is computed at compile time and shall result in an integer value. Furthermore, *constant_expression* and the bounds in *cycle_delay_const_range_expression* can only be 0 or greater.
- The \$ token is used to indicate the end of simulation. For formal verification tools, \$ is used to indicate a finite, but unbounded, range.
- ## [*] is used as an equivalent representation of ## [0 : \$].
- ## [+] is used as an equivalent representation of ## [1 : \$].
- When a range is specified with two expressions, the second expression shall be greater than or equal to the first expression.

- In a *cycle_delay_range*, it shall be illegal for a *constant_primary* to contain a *constant_mintypmax_expression* that is not also a *constant_expression*.

The context in which a sequence occurs determines when the sequence is evaluated. The first expression in a sequence is checked at the first occurrence of the clock tick at or after the expression that triggered evaluation of the sequence. Each successive element (if any) in the sequence is checked at the next subsequent occurrence of the clock.

A *##* followed by a number or range specifies the delay from the current clock tick to the beginning of the sequence that follows. The delay *##1* indicates that the beginning of the sequence that follows is one clock tick later than the current clock tick. The delay *##0* indicates that the beginning of the sequence that follows is at the same clock tick as the current clock tick.

When used as a concatenation between two sequences, the delay is from the end of the first sequence to the beginning of the second sequence. The delay *##1* indicates that the beginning of the second sequence is one clock tick later than the end of the first sequence. The delay *##0* indicates that the beginning of the second sequence is at the same clock tick as the end of the first sequence.

The following are examples of delay expressions. ``true` is a Boolean expression that always evaluates to true and is used for visual clarity. It can be defined as follows:

```
`define true 1

##0 a      // means a
##1 a      // means `true ##1 a
##2 a      // means `true ##1 `true ##1 a
##[0:3]a   // means (a) or (`true ##1 a) or (`true ##1 `true ##1 a) or
            (`true ##1 `true ##1 `true ##1 a)
a ##2 b    // means a ##1 `true ##1 b
```

The sequence

```
req ##1 gnt ##1 !req
```

specifies that `req` be true on the current clock tick, `gnt` shall be true on the first subsequent tick, and `req` shall be false on the next clock tick after that. The *##1* operator specifies one clock tick separation. A delay of more than one clock tick can be specified, as in the following:

```
req ##2 gnt
```

This specifies that `req` shall be true on the current clock tick, and `gnt` shall be true on the second subsequent clock tick, as shown in [Figure 16-2](#).

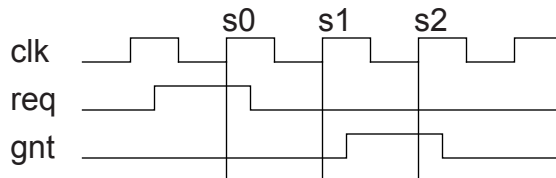

Figure 16-2—Concatenation of sequences

The following specifies that signal `b` shall be true on the *N*th clock tick after signal `a`:

```
a ##N b      // check b on the Nth sample
```

To specify a concatenation of overlapped sequences, where the end point of one sequence coincides with the start of the next sequence, a value of 0 is used, as follows:

```
a ##1 b ##1 c // first sequence seq1
d ##1 e ##1 f // second sequence seq2
(a ##1 b ##1 c) ##0 (d ##1 e ##1 f) // overlapped concatenation
```

In the above example, *c* must be true at the end point of sequence *seq1*, and *d* must be true at the start of sequence *seq2*. When concatenated with 0 clock tick delay, *c* and *d* must be true at the same time, resulting in a concatenated sequence equivalent to the following:

```
a ##1 b ##1 c&&d ##1 e ##1 f
```

It should be noted that no other form of overlapping between the sequences can be expressed using the concatenation operation.

In cases where the delay can be any value in a range, a time window can be specified as follows:

```
req ##[4:32] gnt
```

In the above case, signal *req* must be true at the current clock tick, and signal *gnt* must be true at some clock tick between the 4th and the 32nd clock tick after the current clock tick.

The time window can extend to a finite, but unbounded, range by using *\$* as in the following example:

```
req ##[4:$] gnt
```

A sequence can be unconditionally extended by concatenation with ``true`.

```
a ##1 b ##1 c ##3 `true
```

After satisfying signal *c*, the sequence length is extended by three clock ticks. Such adjustments in the length of sequences can be required when complex sequences are constructed by combining simpler sequences.

16.8 Declaring sequences

A named **sequence** may be declared in the following:

- A module
- An interface
- A program
- A **clocking** block
- A package
- A compilation-unit scope
- A checker
- A generate block

Named sequences are declared using [Syntax 16-5](#).

```

assertion_item_declaration ::= //from A.2.10
    ...
    | sequence_declaration
sequence_declaration ::=
    sequence sequence_identifier [ ( [ sequence_port_list ] ) ] ;
    { assertion_variable_declaration }
    sequence_expr ;
    endsequence [ : sequence_identifier ]
sequence_port_list ::=
    sequence_port_item { , sequence_port_item }
sequence_port_item ::=
    { attribute_instance } [ local [ sequence_lvar_port_direction ] ] sequence_formal_type
    port_identifier { variable_dimension } [ = sequence_actual_arg ]
sequence_lvar_port_direction ::= input | inout | output
sequence_formal_type ::=
    data_type_or_implicit
    | sequence
    | event
    | untyped
sequence_instance ::=
    ps_or_hierarchical_sequence_identifier [ ( [ sequence_list_of_arguments ] ) ]
sequence_list_of_arguments ::=
    [ sequence_actual_arg ] { , [ sequence_actual_arg ] } { , . identifier ( [ sequence_actual_arg ] ) }
    | . identifier ( [ sequence_actual_arg ] ) { , . identifier ( [ sequence_actual_arg ] ) }
sequence_actual_arg ::=
    event_expression
    | sequence_expr
assertion_variable_declaration ::=
    var_data_type list_of_variable_decl_assignments ;

```

Syntax 16-5—Declaring sequence syntax (excerpt from [Annex A](#))

A named sequence may be declared with formal arguments in the optional *sequence_port_list*.

A formal argument may be typed by specifying the type prior to the *port_identifier* of the formal argument. A type shall apply to all formal arguments whose identifiers both follow the type and precede the next type, if any, specified in the port list. Rules particular to the specification and use of typed formal arguments are discussed in [16.8.1](#).

Rules particular to the specification and use of local variable formal arguments are discussed in [16.8.2](#).

A formal argument is said to be *untyped* if there is no type specified prior to its *port_identifier* in the port list. There is no default type for a formal argument.

The supported data types for sequence formal arguments are the types that are allowed for operands in assertion expressions (see [16.6.1](#)) and the keyword **untyped**.

A default actual argument may be specified for a formal argument in the optional associated declaration assignment. The *default_expression* is resolved in the scope containing the sequence declaration.

Requirements for the type of the default actual argument of a typed formal argument are described in [16.8.1](#). The default actual argument of an untyped formal argument may be of any type provided its substitution results in a valid sequence as described in the rewriting algorithm (see [F.4.1](#)).

A formal argument may be referenced in the body of the declaration of the named sequence. A reference to a formal argument may be written in place of various syntactic entities, such as the following:

- identifier
- expression
- `sequence_expr`
- `event_expression`
- the terminal \$ in a *cycle_delay_const_range_expression*

A named sequence may be instantiated by referencing its name. The reference may be a hierarchical name (see [23.6](#)). A named sequence may be instantiated anywhere that a *sequence_expr* may be written, including prior to its declaration. A named sequence may also be instantiated as part of a *sequence_method_call* (see [16.9.11](#), [16.14.5](#)) or as an `event_expression` (see [9.4.2.4](#)). It shall be an error if a cyclic dependency among named sequences results from their instantiations. A cyclic dependency among named sequences results if, and only if, there is a cycle in the directed graph whose nodes are the named sequences and whose edges are defined by the following rule: there is a directed edge from one named sequence to a second named sequence if, and only if, either the first named sequence instantiates the second named sequence within its declaration, including an instance within the declaration of a default actual argument, or there is an instance of the first named sequence that instantiates the second named sequence within an actual argument.

In an instance of a named sequence, actual arguments may be passed to formal arguments. The instance shall provide an actual argument in the list of arguments for each formal argument that does not have a default actual argument declared. The instance may provide an actual argument for a formal argument that has a default actual argument, thereby overriding the default. Actual arguments in the list of arguments may be bound to formal arguments by name or by position.

The terminal \$ may be an actual argument in an instance of a named sequence, either declared as a default actual argument or passed in the list of arguments of the instance. If \$ is an actual argument, then the corresponding formal argument shall be untyped and each of its references either shall be an upper bound in a *cycle_delay_const_range_expression* or shall itself be an actual argument in an instance of a named sequence.

If an instance of a named sequence is within the scope of a local variable (see [16.10](#)), then an actual argument in the list of arguments of the instance may reference the local variable.

Names other than formal arguments that appear in the declaration of a named sequence, including those that appear in default actual arguments, shall be resolved according to the scoping rules from the scope of the declaration of the named sequence. Names appearing in actual arguments in the list of arguments of the instance shall be resolved according to the scoping rules from the scope of the instance of the named sequence.

The sequential behavior and matching semantics of an instance of a named sequence are the same as those of the flattened sequence that is obtained from the body of the declaration of the named sequence by the rewriting algorithm defined in [F.4.1](#). The rewriting algorithm substitutes actual arguments for references to the corresponding formal arguments in the body of the declaration of the named sequence. The rewriting algorithm does not itself account for name resolution and assumes that names have been resolved prior to the substitution of actual arguments. If the flattened sequence is not legal, then the instance is not legal and there shall be an error.

The substitution of an actual argument for a reference to the corresponding untyped formal argument in the rewriting algorithm retains the actual as an expression term. An actual argument shall be enclosed in parentheses and shall be cast to its self-determined type before being substituted for a reference to the corresponding formal argument unless one of the following conditions holds:

- The actual argument is \$.
- The actual argument is a *variable_lvalue*.
- The reference to the formal argument stands as the *sequence_instance* in a *sequence_method_call*.

If the result of the rewriting algorithm is an invalid sequence, an error shall occur.

```
sequence s1;
  @(posedge clk) a ##1 b ##1 c;
endsequence
sequence s2;
  @(posedge clk) d ##1 e ##1 f;
endsequence
sequence s3;
  @(negedge clk) g ##1 h ##1 i;
endsequence
sequence s4;
  @(edge clk) j ##1 k ##1 l;
endsequence
```

In this example, named sequences *s1* and *s2* are evaluated on successive **posedge** events of *clk*. The named sequence *s3* is evaluated on successive **negedge** events of *clk*. The named sequence *s4* is evaluated on successive alternating **posedge** and **negedge** events of *clk*.

Another example of named sequence declaration, which includes arguments, is shown below:

```
sequence s20_1(data,en);
  (!frame && (data==data_bus)) ##1 (c_be[0:3] == en);
endsequence
```

Named sequence *s20_1* does not specify a clock. In this case, a clock would be inherited from some external source, such as a **property** or an **assert** statement. An example of instantiating a named sequence is shown below:

```
sequence s;
  a ##1 b ##1 c;
endsequence
sequence rule;
  @(posedge sysclk)
  trans ##1 start_trans ##1 s ##1 end_trans;
endsequence
```

Named sequence *rule* in the preceding example is equivalent to the following:

```
sequence rule;
  @(posedge sysclk)
  trans ##1 start_trans ##1 (a ##1 b ##1 c) ##1 end_trans ;
endsequence
```

The following example illustrates an illegal cyclic dependency among the named sequences *s1* and *s2*:

```
sequence s1;
  @(posedge sysclk) (x ##1 s2);
```

```

endsequence
sequence s2;
  @(posedge sysclk) (y ##1 s1);
endsequence

```

16.8.1 Typed formal arguments in sequence declarations

The data type specified for a formal argument of a sequence may be the keyword **untyped**. A formal argument shall be untyped (see [16.8](#)) if its data type is **untyped**. The semantics of binding an actual argument expression to a formal with a data type of **untyped** shall be the same as the semantics for an untyped formal. The keyword **untyped** shall be used if an untyped formal argument follows a data type in the formal argument list.

If a formal argument of a named sequence is typed, then the type shall be **sequence**, **event**, or one of the types allowed in [16.6.1](#). The following rules apply to typed formal arguments and their corresponding actual arguments, including default actual arguments declared in a named sequence:

- If the formal argument is of type **sequence**, then the actual argument shall be a *sequence_expr* and each reference to the formal argument shall be in a place where a *sequence_expr* may be written.
- If the formal argument is of type **event**, then the actual argument shall be an *event_expression* and each reference to the formal argument shall be in a place where an *event_expression* may be written.
- Otherwise, the self-determined result type of the actual argument shall be cast compatible (see [6.22.4](#)) with the type of the formal argument. If the actual argument is a *variable_lvalue*, references to the formal shall be considered as having the formal's type with any assignment to the formal being treated as though there was a subsequent assignment from the formal to the actual argument. If the actual argument is not a *variable_lvalue*, the actual argument shall be cast to the type of the formal argument before being substituted for a reference to the formal argument in the rewriting algorithm (see [F.4.1](#)).

For example, a Boolean expression may be passed as actual argument to a formal argument of type **sequence** because a Boolean expression is a *sequence_expr*. A formal argument of type **sequence** may not be referenced as the *expression_or_dist* operand of a *goto_repetition* (see [16.9.2](#)), regardless of the corresponding actual argument, because a *sequence_expr* may not be written in that position.

A reference to a typed formal argument within a *sequence_match_item* (see [16.10](#)) shall not stand as the *variable_lvalue* in either an *operator_assignment* or an *inc_or_dec_expression* unless the formal argument is a local variable argument (see [16.8.2](#), [16.13.6](#)).

Two examples of declaring formal arguments are shown below. All of the formal arguments of *s1* are untyped. The formal arguments *w* and *y* of *s2* are untyped, while the formal argument *x* has type **bit**.

```

sequence s1(w, x, y);
  w ##1 x ##[2:10] y;
endsequence

sequence s2(w, y, bit x);
  w ##1 x ##[2:10] y;
endsequence

```

The following instances of *s1* and *s2* are equivalent:

```

s1(.w(a), .x(bit'(b)), .y(c))
s2(.w(a), .x(b), .y(c))

```

In the instance of *s2* above, if *b* happens to be 8 bits wide then it will be cast to **bit** by truncation since it is being passed to a formal argument of type **bit**. Similarly, if an expression of type **bit** is passed as actual argument to a formal argument of type **byte**, then the expression is extended to a **byte**.

If a reference to a typed formal argument appears in the specification of a *cycle_delay_range*, a *boolean_abbrev*, or a *sequence_abbrev* (see [16.9.2](#)), then the type of the formal argument shall be **shortint**, **int**, or **longint**. The following example illustrates such usage of formal arguments:

```
sequence delay_arg_example (max, shortint delay1, delay2, min);
  x ##delay1 y[*min:max] ##delay2 z;
endsequence

parameter my_delay=2;
cover property (delay_arg_example($, my_delay, my_delay-1, 3));
```

The cover property in the preceding example is equivalent to the following:

```
cover property (x ##2 y[*3:$] ##1 z);
```

The following shows an example of a formal argument with **event** type:

```
sequence event_arg_example (event ev);
  @(ev) x ##1 y;
endsequence

cover property (event_arg_example(posedge clk));
```

The cover property in the preceding example is equivalent to the following:

```
cover property (@(posedge clk) x ##1 y);
```

If the intent is to pass as actual argument an expression that will be combined with an *edge_identifier* to create an *event_expression*, then the formal argument shall not be typed with type **event**. The following example illustrates such usage:

```
sequence event_arg_example2 (reg sig);
  @(posedge sig) x ##1 y;
endsequence

cover property (event_arg_example2(clk));
```

The cover property in the preceding example is equivalent to the following:

```
cover property (@(posedge clk) x ##1 y);
```

Another example, in which a local variable is used to sample a formal argument, shows how to get the effect of “pass by value.” Pass by value is not currently supported as a mode of argument passing.

```
sequence s(bit a, bit b);
  bit loc_a;
  (1'b1, loc_a = a) ##0
  (t == loc_a) [*0:$] ##1 b;
endsequence
```

16.8.2 Local variable formal arguments in sequence declarations

A formal argument of a named sequence may be designated as a local variable argument by specifying the keyword **local** in the port item, followed optionally by one of the directions **input**, **inout**, or **output**. If no direction is specified explicitly, then the direction **input** shall be inferred. If the keyword **local** is specified in a port item, then the type of that argument shall be specified explicitly in that port item and shall not be inferred from a previous argument. The type of a local variable argument shall be one of the types allowed in [16.6.1](#). If one of the directions **input**, **inout**, or **output** is specified in a port item, then the keyword **local** shall be specified in that port item.

The designation of a formal argument as a local variable argument of a given direction and type shall apply to subsequent identifiers in the port list as long as none of the subsequent port items specifies the keyword **local** or an explicit type. In other words, if a port item consists only of an identifier and if the nearest preceding argument with an explicitly specified type also specifies the keyword **local**, then the port item is a local variable argument with the same direction and type as that preceding argument.

If a local variable formal argument has direction **input**, then a default actual argument may be specified for that argument in the optional declaration assignment in the port item, subject to the rules for default actual arguments described in [16.8](#). It shall be illegal to specify a default actual argument for a local variable argument of direction **inout** or **output**.

An example showing legal declaration of a named sequence using local variable formal arguments is as follows:

```

logic b_d, d_d;
sequence legal_loc_var_formal (
  local inout logic a,
  local logic b = b_d, // input inferred, default actual argument b_d
                c,      // local input logic inferred, no default
                // actual argument
  d = d_d, // local input logic inferred, default actual
                // argument d_d
  logic e, f          // e and f are not local variable formal arguments
);
logic g = c, h = g || d;
...
endsequence

```

An example showing illegal declaration of a named sequence using local variable formal arguments is shown as follows:

```

sequence illegal_loc_var_formal (
  output logic a, // illegal: local must be specified with
                  // direction
  local inout logic b,
  c = 1'b0, // default actual argument illegal for inout
  local d = expr, // illegal: type must be specified explicitly
  local event e, // illegal: event is a type disallowed in
                  // 16.6.1
  local logic f = g // g shall not refer to the local variable
                  // below and must be resolved upward from
                  // this declaration
);
logic g = b;
...
endsequence

```

In general, a local variable formal argument behaves in the same way as a local variable declared in an *assertion_variable_declaration*. The rules in [16.10](#) for assigning to and referencing local variables, including the rules of local variable flow, apply to local variable formal arguments with the following provisions:

- Without further specification, the term “*local variable*” shall mean either a local variable formal argument or a local variable declared in an *assertion_variable_declaration*.
- At the beginning of each evaluation attempt of an instance of a named sequence, a new copy of each of its local variable formal arguments shall be created.
- A local variable formal argument with direction **input** or **inout** shall be treated like a local variable declared in an *assertion_variable_declaration* with a declaration assignment. The initial value for the local variable formal argument is provided by the associated actual argument for the instance. The self-determined result type of the actual argument shall be cast compatible (see [6.22.4](#)) with the type of the local variable formal argument. The value of the actual argument shall be cast to the type of the local variable formal argument before being assigned as initial value to the local variable formal argument. This assignment is referred to as the “*initialization assignment*” of the local variable formal argument. Initialization of all input and inout local variable formal arguments shall be performed before initialization of any local variable declared in an *assertion_variable_declaration*. The expression of a declaration assignment to a local variable declared in an *assertion_variable_declaration* may refer to a local variable formal argument of direction **input** or **inout**.
- If a local variable formal argument of direction **input** or **inout** is bound to an actual argument in the argument list of an instance and if the actual argument references a local variable, then it shall be an error if that local variable is unassigned at the point of the reference in the context of the instance.
- A local variable formal argument of direction **output** shall be unassigned at the beginning of the evaluation attempt of the instance.
- The entire actual argument expression bound to an **inout** or **output** local variable formal argument shall itself be a reference to a local variable whose scope includes the instance and with whose type the type of the local variable formal argument is cast compatible. It shall be an error if references to the same local variable are bound as actual arguments to two or more local variable formal arguments of direction **inout** or **output**. It shall be an error if there exists a match of the named sequence for which an inout or output local variable formal argument is unassigned at the completion of the match. At the completion of a match of the instance of the named sequence, the value of the inout or output local variable formal argument shall be cast to the type of and assigned to the local variable whose reference is the associated actual argument. If multiple threads of evaluation of the instance of the named sequence match, then multiple threads of evaluation shall continue in the instantiation context, each with its own copy of the actual argument local variable. For each matching thread of the instance of the named sequence, at the completion of the match of that thread the value of the local variable formal argument in that thread shall be cast to the type of and assigned to the associated copy of the actual argument local variable.
- It shall be an error for an instance of a named sequence with an **inout** or **output** local variable formal argument to admit an empty match.
- It shall be an error to apply any of the sequence methods `triggered` (see [16.9.11](#), [16.14.6](#)) or `matched` (see [16.14.5](#)) to an instance of a named sequence with an input or inout local variable formal argument.

The following example illustrates legal usage of a local variable formal argument:

```
sequence sub_seq2(local inout int lv);  
    (a ##1 !a, lv += data_in)  
    ##1 !b[*0:$] ##1 b && (data_out == lv);  
endsequence  
sequence seq2;
```

```

int v1;
(c, v1 = data)
##1 sub_seq2(v1) // lv is initialized by assigning it the value of v1;
                // when the instance sub_seq2(v1) matches, v1 is
                // assigned the value of lv
##1 (do1 == v1);
endsequence

```

The matching behavior of seq2 is equivalent to that of seq2_inlined as follows:

```

sequence seq2_inlined;
int v1, lv;
(c, v1 = data) ##1
(
  (1, lv = v1) ##0
  (a ##1 !a, lv += data_in)
  ##1 (!b[*0:$] ##1 b && (data_out == lv), v1 = lv)
)
##1 (do1 == v1);
endsequence

```

Untyped arguments provide an alternative mechanism for passing local variables to an instance of a subsequence, including the capability to assign to the local variable in the subsequence and later reference the value assigned in the instantiation context (see [16.10](#)).

16.9 Sequence operations

16.9.1 Operator precedence

Operator precedence and associativity are listed in [Table 16-1](#). The highest precedence is listed first.

Table 16-1—Operator precedence and associativity

SystemVerilog expression operators	Associativity
[*] [=] [->]	—
##	Left
throughout	Right
within	Left
intersect	Left
and	Left
or	Left

16.9.2 Repetition in sequences

The syntax for sequence repetition is shown in [Syntax 16-6](#).

```

sequence_expr ::=
  ...
  | expression_or_dist [ boolean_abbrev ]
// from A.2.10

```

```

| sequence_instance [ sequence_abbrev ]
| ( sequence_expr { , sequence_match_item } ) [ sequence_abbrev ]
...
boolean_abbrev ::=
  consecutive_repetition
| non_consecutive_repetition
| goto_repetition
sequence_abbrev ::= consecutive_repetition
consecutive_repetition ::=
  [* const_or_range_expression ]
| [*]
| [+]
non_consecutive_repetition ::= [= const_or_range_expression ]
goto_repetition ::= [-> const_or_range_expression ]
const_or_range_expression ::=
  constant_expression
| cycle_delay_const_range_expression
cycle_delay_const_range_expression ::=
  constant_expression : constant_expression
| constant_expression : $

```

Syntax 16-6—Sequence repetition syntax (excerpt from [Annex A](#))

The number of iterations of a repetition can either be specified by exact count or be required to fall within a finite range. If specified by exact count, then the number of iterations is defined by a non-negative integer constant expression. If required to fall within a finite range, then the minimum number of iterations is defined by a non-negative integer constant expression; and the maximum number of iterations either is defined by a non-negative integer constant expression or is \$, indicating a finite, but unbounded, maximum.

If both the minimum and maximum numbers of iterations are defined by non-negative integer constant expressions (see [11.2.1](#)), then the minimum number shall be less than or equal to the maximum number.

The following three kinds of repetition are provided:

- *Consecutive repetition* ([*const_or_range_expression]): Consecutive repetition specifies finitely many iterative matches of the operand sequence, with a delay of one clock tick from the end of one match to the beginning of the next. The overall repetition sequence matches at the end of the last iterative match of the operand. [*] is an equivalent representation of [*0:\$] and [+] is an equivalent representation of [*1:\$].
- *Goto repetition* ([->const_or_range_expression]): Goto repetition specifies finitely many iterative matches of the operand Boolean expression, with a delay of one or more clock ticks from one match of the operand to the next successive match and no match of the operand strictly in between. The overall repetition sequence matches at the last iterative match of the operand.
- *Nonconsecutive repetition* ([=const_or_range_expression]): Nonconsecutive repetition specifies finitely many iterative matches of the operand Boolean expression, with a delay of one or more clock ticks from one match of the operand to the next successive match and no match of the operand strictly in between. The overall repetition sequence matches at or after the last iterative match of the operand, but before any later match of the operand.

The effect of consecutive repetition of a subsequence within a sequence can be achieved by explicitly iterating the subsequence, as follows:

a ##1 b ##1 b ##1 b ##1 c

Using the consecutive repetition operator [**3*], which indicates three iterations, this sequential behavior is specified more succinctly:

a ##1 b [**3*] ##1 c

A consecutive repetition specifies that the operand sequence shall match a specified number of times. The consecutive repetition operator [**N*] specifies that the operand sequence must match *N* times in succession. For example:

a [**3*] means a ##1 a ##1 a

Using 0 as the repetition number, an empty sequence results, as follows:

a [**0*]

An empty sequence is one that matches over zero clock ticks and does not match over any positive number of clock ticks. The following rules apply for concatenating sequences with empty sequences. An empty sequence is denoted as *empty*, and a sequence is denoted as *seq*.

- (empty ##0 seq) does not result in a match.
- (seq ##0 empty) does not result in a match.
- (empty ##n seq), where n is greater than 0, is equivalent to (##(n-1) seq).
- (seq ##n empty), where n is greater than 0, is equivalent to (seq ##(n-1) `true).

For example:

b ##1 (a[**0*] ##0 c)

produces no match of the sequence.

b ##1 a[**0:1*] ##2 c

is equivalent to

(b ##2 c) **or** (b ##1 a ##2 c)

The syntax allows combination of a delay and repetition in the same sequence. The following are both allowed:

```

`true ##3 (a [*3]) // means `true ##1 `true ##1 `true ##1 a ##1 a ##1 a
(`true ##2 a) [*3] // means (`true ##2 a) ##1 (`true ##2 a) ##1
// (`true ##2 a), which in turn means `true ##1 `true
##1
// a ##1 `true ##1 `true ##1 a ##1 `true ##1 `true ##1 a

```

A sequence can be repeated as follows:

(a ##2 b) [**5*]

This is the same as the following:

(a ##2 b ##1 a ##2 b ##1 a ##2 b ##1 a ##2 b ##1 a ##2 b)

A repetition with a range of minimum min and maximum max number of iterations can be expressed with the consecutive repetition operator $[* \text{min}:\text{max}]$.

For example:

$(a \ \#\#2 \ b) [*1:5]$

is equivalent to

$(a \ \#\#2 \ b)$
or $(a \ \#\#2 \ b \ \#\#1 \ a \ \#\#2 \ b)$
or $(a \ \#\#2 \ b \ \#\#1 \ a \ \#\#2 \ b \ \#\#1 \ a \ \#\#2 \ b)$
or $(a \ \#\#2 \ b \ \#\#1 \ a \ \#\#2 \ b \ \#\#1 \ a \ \#\#2 \ b \ \#\#1 \ a \ \#\#2 \ b)$
or $(a \ \#\#2 \ b \ \#\#1 \ a \ \#\#2 \ b \ \#\#1 \ a \ \#\#2 \ b \ \#\#1 \ a \ \#\#2 \ b \ \#\#1 \ a \ \#\#2 \ b)$

Similarly,

$(a[*0:3] \ \#\#1 \ b \ \#\#1 \ c)$

is equivalent to

$(b \ \#\#1 \ c)$
or $(a \ \#\#1 \ b \ \#\#1 \ c)$
or $(a \ \#\#1 \ a \ \#\#1 \ b \ \#\#1 \ c)$
or $(a \ \#\#1 \ a \ \#\#1 \ a \ \#\#1 \ b \ \#\#1 \ c)$

To specify a finite, but unbounded, number of iterations, the dollar sign ($\$$) is used. For example, the repetition

$a \ \#\#1 \ b [*1:\$] \ \#\#1 \ c$

matches over an interval of three or more consecutive clock ticks if a is true on the first clock tick, c is true on the last clock tick, and b is true at every clock tick strictly in between the first and the last.

Specifying the number of iterations of a repetition by exact count is equivalent to specifying a range in which the minimum number of repetitions is equal to the maximum number of repetitions. In other words, $\text{seq}[*n]$ is equivalent to $\text{seq}[*n:n]$.

The goto repetition (nonconsecutive exact repetition) takes a Boolean expression rather than a sequence as operand. It specifies the iterative matching of the Boolean expression at clock ticks that are not necessarily consecutive and ends at the last iterative match. For example:

$a \ \#\#1 \ b [->2:10] \ \#\#1 \ c$

matches over an interval of consecutive clock ticks provided a is true on the first clock tick, c is true on the last clock tick, b is true on the penultimate clock tick, and, including the penultimate, there are at least 2 and at most 10 not necessarily consecutive clock ticks strictly in between the first and last on which b is true. This sequence is equivalent to the following:

$a \ \#\#1 ((!b[*0:\$] \ \#\#1 \ b) [*2:10]) \ \#\#1 \ c$

The nonconsecutive repetition is like the goto repetition except that a match does not have to end at the last iterative match of the operand Boolean expression. The use of nonconsecutive repetition instead of goto repetition allows the match to be extended by arbitrarily many clock ticks provided the Boolean expression is false on all of the extra clock ticks. For example:

```
a ##1 b [=2:10] ##1 c
```

matches over an interval of consecutive clock ticks provided *a* is true on the first clock tick, *c* is true on the last clock tick, and there are at least 2 and at most 10 not necessarily consecutive clock ticks strictly in between the first and last on which *b* is true. This sequence is equivalent to the following:

```
a ##1 ((!b [*0:$] ##1 b) [*2:10]) ##1 !b[*0:$] ##1 c
```

The consecutive repetition operator can be applied to general sequence expressions, but the goto repetition and nonconsecutive repetition operators can be applied only to Boolean expressions. In particular, goto repetition and nonconsecutive repetition cannot be applied to a Boolean expression to which a sequence match item (see [16.10](#), [16.11](#)) has been attached. For example, the following is a legal sequence expression:

```
(b[->1], v = e) [*2]
```

but the following is illegal:

```
(b, v = e) [->2]
```

16.9.3 Sampled value functions

This subclause describes the system functions available for accessing sampled values of an expression. These functions include the capability to access current sampled value, access sampled value in the past, or detect changes in sampled value of an expression. Sampling of an expression is explained in [16.5](#). Automatic variables, such as loop control variables, local variables (see [16.10](#)) and the sequence methods `triggered` and `matched` are not allowed in the argument expressions passed to these functions. The following functions are provided:

```
$sampled ( expression )
$rose ( expression [ , [clocking_event] ] )
$fell ( expression [ , [clocking_event] ] )
$stable ( expression [ , [clocking_event] ] )
$changed ( expression [ , [clocking_event] ] )
$past ( expression [ , [number_of_ticks] [ , [expression2] [ , [clocking_event]] ] ] )
```

The use of these functions is not limited to assertion features; they may be used as expressions in procedural code as well. All variables referenced in the actual argument expressions passed to these functions shall be static. The clocking event, although optional as an explicit argument to the functions, `$past`, `$rose`, `$stable`, `$changed`, and `$fell`, is required for their semantics. The clocking event is used to sample the value of the argument expression.

The function `$sampled` does not use a clocking event.

For a sampled value function other than `$sampled`, the clocking event shall be explicitly specified as an argument or inferred from the code where the function is called. The following rules are used to infer the clocking event:

- If called in an assertion, the appropriate clocking event from the assertion is used.
- If called in an action block of a singly clocked assertion, the clock of the assertion is used.
- If called in an action block of a multiclocked assertion, the leading clock of the assertion is used.
- If called in a procedural block, the inferred clock, if any, for the procedural code (see [16.15.6](#)) is used.

Otherwise, default clocking (see [14.12](#)) is used.

The `$sampled` function returns the value of the expression sampled in the Preponed region of the simulation time step in which the function is called. The value is stable throughout the simulation step.

The value of an expression sampled in the Preponed region corresponding to time 0 is the result of evaluating the expression using the initial values of the variables comprising the expression. The initial value of a static variable is the value assigned in its declaration, or, in the absence of such an assignment, it is the default (or uninitialized) value of the corresponding type (see [6.8, Table 6-7](#)). The initial value of any other variable or signal is the default value of the corresponding type (see [6.8, Table 6-7](#)). For example, if `$sampled(y)` is called at time 0, and `y` is of type `logic`, the value returned is `x`.

The use of `$sampled` in assertions, although allowed, is redundant, as the result of the function is identical to the sampled value of the expression itself used in the assertion.

The following functions are called value change functions and are provided to detect changes in sampled values: `$rose`, `$fell`, `$stable`, and `$changed`.

A value change function detects a change (or, in the case of `$stable`, lack of change) in the sampled value of an expression. The change (or lack of change) is determined by comparing the sampled value of the expression from the Preponed region of the current time step with the sampled value of the expression from the Preponed region of the most recent strictly prior time step in which the clocking event occurred. Here, the current time step refers to the simulation time step in which the function is called. The result of a value change function is true or false and a call to a value change function may be used as a Boolean expression. The results of value change functions shall be determined as follows:

- `$rose` returns true if the least significant bit of the expression changed to 1. Otherwise, it returns false.
- `$fell` returns true if the least significant bit of the expression changed to 0. Otherwise, it returns false.
- `$stable` returns true if the value of the expression did not change. Otherwise, it returns false.
- `$changed` returns true if the value of the expression changed. Otherwise, it returns false.

When these functions are called at or before the simulation time step in which the first clocking event occurs, the results are computed by comparing the value of the expression sampled in the Preponed region of the current time step with the result of the expression evaluated using the initial values of the variables comprising the expression. The initial value of a static variable is the value assigned in its declaration, or in the absence of such an assignment it is the default (or uninitialized) value of the corresponding type (see [6.8, Table 6-7](#)). The initial value of any other variable or signal is the default value of the corresponding type (see [6.8, Table 6-7](#)).

[Figure 16-3](#) illustrates two examples of value changes:

- Value change expression `e1` is defined as `$rose(req)`.
- Value change expression `e2` is defined as `$fell(ack)`.

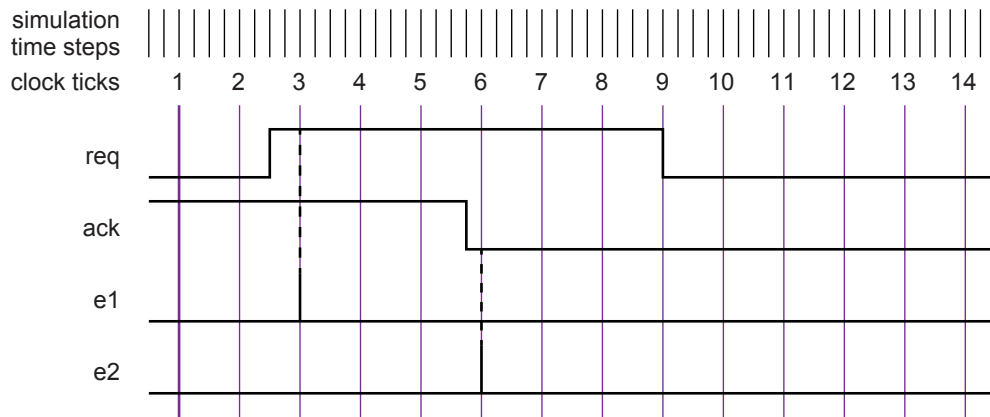

Figure 16-3—Value change expressions

The clock ticks used for sampling the variables are derived from the clock for the property, which is different from the simulation time steps. Assume, for now, that this clock is defined elsewhere. At clock tick 3, *e1* occurs because the value of *req* at clock tick 2 was low and the value at clock tick 3 is high. Similarly, *e2* occurs at clock tick 6 because the value of *ack* was sampled as high at clock tick 5 and sampled as low at clock tick 6.

The following example illustrates the use of `$rose` in SystemVerilog code outside assertions:

```
always @(posedge clk)
    reg1 <= a & $rose(b);
```

In this example, the clocking event `@(posedge clk)` is applied to `$rose`. `$rose` is true whenever the sampled value of *b* changed to 1 from its sampled value at the previous tick of the clocking event.

Past sampled values can be accessed with the `$past` function. The following three optional arguments are provided:

- *expression2* is used as a gating expression for the clocking event.
- *number_of_ticks* specifies the number of clock ticks in the past.
- *clocking_event* specifies the clocking event for sampling *expression1*.

expression1 and *expression2* may be any expression allowed in assertions. If *expression2* is not specified, then it defaults to `1'b1`.

number_of_ticks shall be 1 or greater. If *number_of_ticks* is not specified, then it defaults to 1.

`$past` returns the value of *expression1* that was sampled in the Preponed region of a particular time step strictly prior to the one in which `$past` is evaluated. If *number_of_ticks* equals *k* and if *ev* is the event expression underlying *clocking_event*, then the particular time step is the *k*th strictly prior time step in which the event *ev* **iff** *expression2* occurred. If there do not exist *k* strictly prior time steps in which the event *ev* **iff** *expression2* occurred, then the value returned from the `$past` function is the result of evaluating *expression1* using the initial values of the variables comprising it. The initial value of a static variable is the value assigned in its declaration, or in the absence of such an assignment it is the default (or uninitialized) value of the corresponding type (see 6.8, Table 6-7). The initial value of any other variable or signal is the default value of the corresponding type (see 6.8, Table 6-7).

The clocking event for `$past` shall be explicitly specified through the *clocking_event* argument or inferred from the code where `$past` is called. The rules for inferring the clocking event are described previously.

When intermediate optional arguments between two arguments are not needed, a comma shall be placed for each omitted argument. For example:

```
$past(in1, , enable);
```

Here, a comma is specified to omit *number_of_ticks*. The default of 1 is used for the empty *number_of_ticks* argument. There is no need to include a comma for the omitted *clocking_event* argument, as it does not fall within the specified arguments.

`$past` can be used in any SystemVerilog expression. An example is shown below.

```
always @(posedge clk)
  reg1 <= a & $past(b);
```

In this example, the inferred clocking event `@(posedge clk)` is applied to `$past`. `$past` is evaluated in the current occurrence of `(posedge clk)` and returns the value of `b` sampled at the previous occurrence of `(posedge clk)`.

When *expression2* is specified, the sampling of *expression1* is performed based on its clock gated with *expression2*. For example:

```
always @(posedge clk)
  if (enable) q <= d;

always @(posedge clk)
  assert property (done | => (out == $past(q, 2, enable)) );
```

In this example, the sampling of `q` for evaluating `$past` is based on the following clocking expression:

```
posedge clk iff enable
```

The clocking event argument of a sampled value function may be different from the clocking event of the context in which it is called, as determined by the clock resolution (see [16.17](#)).

Consider the following assertions:

```
bit clk, fclk, req, gnt, en;
...
a1: assert property
  (@(posedge clk) en && $rose(req) | => gnt);

a2: assert property
  (@(posedge clk) en && $rose(req, @(posedge fclk)) | => gnt);
```

Both assertions `a1` and `a2` read: “whenever `en` is high and `req` rises, at the next cycle `gnt` must be asserted.” In both assertions, the rise of `req` occurs if and only if the sampled value of `req` at the current `posedge` of `clk` is 1'b1 and the sampled value of `req` at a particular prior point is distinct from 1'b1. The assertions differ in the specification of the prior point. In `a1` the prior point is the preceding `posedge` of `clk`, while in `a2` the prior point is the most recent prior `posedge` of `fclk`.

As another example,

```
always_ff @(posedge clk1)
```

```
reg1 <= $rose(b, @(posedge clk2));
```

Here, `reg1` is updated in each time step in which `posedge clk1` occurs, using the value returned from the `$rose` sampled value function in that time step. `$rose` compares the sampled value of the least significant bit of `b` from the current time step (one in which `posedge clk1` occurs) with the sampled value of the least significant bit of `b` in the strictly prior time step in which `posedge clk2` occurs.

The following example is illegal if it is not within the scope of a default clocking because no clock can be inferred:

```
always @(posedge clk) begin
    ...
    @(negedge clk2);
    x = $past(y, 5); // illegal if not within default clocking
end
```

This example is legal if it is within the scope of a default clocking.

16.9.4 Global clocking past and future sampled value functions

This subclause describes the system functions available for accessing the nearest past and future values of an expression as sampled by the global clock. They may be used only if global clocking is defined (see [14.14](#)). These functions include the capability to access the sampled value at the global clock tick that immediately precedes or follows the time step at which the function is called. Sampled value is explained in [16.5](#). The following functions are provided:

Global clocking past sampled value functions are as follows:

```
$past_gclk ( expression )
$rose_gclk ( expression )
$fell_gclk ( expression )
$stable_gclk ( expression )
$changed_gclk ( expression )
```

Global clocking future sampled value functions are as follows:

```
$future_gclk ( expression )
$rising_gclk ( expression )
$falling_gclk ( expression )
$steady_gclk ( expression )
$changing_gclk ( expression )
```

The behavior of the global clocking past sampled value functions can be defined using the sampled value functions as follows (the symbol \equiv means here “is equivalent by definition”):

```
$past_gclk(v)      ≡ $past(v, , , @ $global_clock)
$rose_gclk(v)      ≡ $rose(v, @ $global_clock)
$fell_gclk(v)      ≡ $fell(v, @ $global_clock)
$stable_gclk(v)    ≡ $stable(v, @ $global_clock)
$changed_gclk(v)   ≡ $changed(v, @ $global_clock)
```

The global clocking future sampled value functions are similar except that they use the subsequent value of the expression.

`$future_gclk(v)` is the sampled value of `v` at the next global clocking tick.

The other functions are defined as follows:

- `$rising_gclk(expression)` returns true if the sampled value of the least significant bit of the expression is changing to 1 at the next global clocking tick. Otherwise, it returns false.
- `$falling_gclk(expression)` returns true if the sampled value of the least significant bit of the expression is changing to 0 at the next global clocking tick. Otherwise, it returns false.
- `$steady_gclk(expression)` returns true if the sampled value of the expression does not change at the next global clock tick. Otherwise, it returns false.
- `$changing_gclk(expression)` is the complement of `$steady_gclk`, i.e., `!$steady_gclk(expression)`.

The global clocking sampled value functions may be invoked only in *property_expr* or in *sequence_expr*; this implies that they shall not be used in assertion action blocks. The global clocking past sampled value functions are a special case of the sampled value functions, and therefore the regular restrictions imposed on the sampled value function arguments apply (see [16.9.3](#)). Additional restrictions are imposed on the usage of the global clocking future sampled value functions: they shall not be nested and they shall not be used in assertions containing sequence match items (see [16.10](#), [16.11](#)).

The following example illustrates the illegal usage of the global clocking future sampled value functions:

```
// Illegal: global clocking future sampled value functions
// shall not be nested
a1: assert property (@clk $future_gclk(a || $rising_gclk(b));
sequence s;
    bit v;
    (a, v = a) ##1 (b == v) [->1];
endsequence : s

// Illegal: a global clocking future sampled value function shall not
// be used in an assertion containing sequence match items
a2: assert property (@clk s | => $future_gclk(c));
```

Even though global clocking future sampled value functions depend on future values of their arguments, the interval of simulation time steps for an evaluation attempt of an assertion containing global clocking future sampled value functions is defined as though the future sampled values were known in advance. The end of the evaluation attempt is defined to be the last tick of the assertion clock and is not delayed any additional time steps up to the next global clocking tick.

The behavior of **disable iff** and other asynchronous assertion related controls such as `$assertkill` (see [20.11](#) and [20.12](#)) is with respect to the interval of the evaluation attempt defined above. If, for example, `$assertkill` is executed in a time step strictly after the last tick of the assertion clock for the evaluation attempt, then it shall not affect that attempt, even if `$assertkill` is executed no later than the next global clocking tick.

Execution of the action block of an assertion containing global clocking future sampled value functions shall be delayed until the global clocking tick that follows the last tick of the assertion clock for the attempt. If the evaluation attempt fails and `$error` is called by default (see [16.15.1](#)), then `$error` shall be called at the global clocking tick that follows the last tick of the assertion clock.

A tool specific message that reports the starting or ending time step of an evaluation attempt of an assertion containing global clocking future sampled functions shall be consistent with the definition above of the interval of simulation time steps for the evaluation attempt. The message may also report the time step in

which it is written, which may be that of the global clocking tick that follows the last tick of the assertion clock.

Example 1:

[Table 16-2](#) shows the values returned by the global clocking future sampled value functions for `sig` at different time moments.

The following assertion states that the signal may change only on falling clock:

```
a1: assert property (@$global_clock $changing_gclk(sig)
                        |-> $falling_gclk(clk))
    else $error("sig is not stable");
```

[Figure 16-4](#) shows that this property is violated at time 80. The vertical arrows indicate the ticks of the global clock. The error message `$error("sig is not stable")` is executed at time 90.

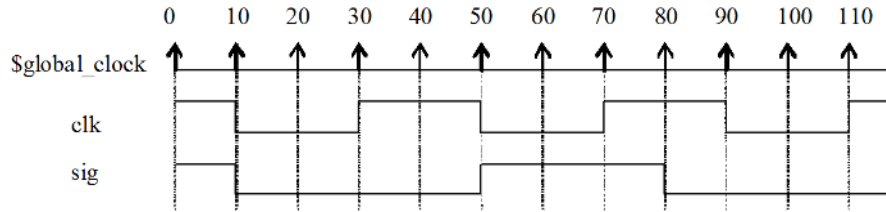

Figure 16-4—Future value change

Table 16-2—Global clocking future sampled value functions

Time	\$sampled(sig)	\$future_gclk(sig)	\$rising_gclk(sig)	\$falling_gclk(sig)	\$changing_gclk(sig)	\$steady_gclk(sig)
10	1'b1	1'b0	1'b0	1'b1	1'b1	1'b0
30	1'b0	1'b0	1'b0	1'b0	1'b0	1'b1
40	1'b0	1'b0	1'b0	1'b0	1'b0	1'b1
50	1'b0	1'b1	1'b1	1'b0	1'b1	1'b0
80	1'b1	1'b0	1'b0	1'b1	1'b1	1'b0

Example 2:

The following assumption states that a signal `sig` must remain stable between two falling edges of a clock `clk` as sampled by global clocking. This differs from the property in Example 1 in the case where the first falling edge of `clk` has not yet occurred. In Example 1, `sig` is not allowed to change in that case, but in this example `sig` can toggle freely while waiting for `clk` to begin.

```
a2: assume property (@$global_clock
                      $falling_gclk(clk) ##1 (!$falling_gclk(clk) [*1:$]) |->
                      $steady_gclk(sig));
```

Example 3:

Assume that the signal `rst` is high between times 82 and 84, and is low at all other time moments. Then the following assertion:

```
a3: assert property (@$global_clock disable iff (rst) $changing_gclk(sig)
                    |-> $falling_gclk(clk))
    else $error("sig is not stable");
```

fails at time 80 (see [Figure 16-4](#)) since `rst` is inactive at time 80. The interval of the failing evaluation attempt starts and ends at time 80. Although `rst` is active prior to the execution of the action block at time 90, the attempt is not disabled.

Example 4:

In some cases, the global clocking future value functions provide a more natural expression of a property than the past value functions. For example, the following two assertions are equivalent:

```
// A ##1 is needed in a4 due to the corner case at cycle 0
a4: assert property (##1 $stable_gclk(sig));

// In a5, there is no issue at cycle 0
a5: assert property ($steady_gclk(sig));
```

16.9.5 AND operation

The binary operator **and** is used when both operands are expected to match, but the end times of the operand sequences can be different (see [Syntax 16-7](#)).

```
sequence_expr ::= // from A.2.10
...
| sequence_expr and sequence_expr
```

Syntax 16-7—And operator syntax (excerpt from [Annex A](#))

The two operands of **and** are sequences. The requirement for the match of the **and** operation is that both the operands shall match. The operand sequences start at the same time. When one of the operand sequences matches, it waits for the other to match. The end time of the composite sequence is the end time of the operand sequence that completes last.

When `te1` and `te2` are sequences, then the composite sequence

```
te1 and te2
```

matches if `te1` and `te2` match. The end time is the end time of either `te1` or `te2`, whichever matches last.

The following example is a sequence with operator **and**, where the two operands are sequences:

```
(te1 ##2 te2) and (te3 ##2 te4 ##2 te5)
```

The operation as illustrated in [Figure 16-5](#) shows the evaluation attempt at clock tick 8. Here, the two operand sequences are `(te1 ##2 te2)` and `(te3 ##2 te4 ##2 te5)`. The first operand sequence requires that first `te1` evaluates to true followed by `te2` two clock ticks later. The second sequence requires that first `te3` evaluates to true followed by `te4` two clock ticks later, followed by `te5` two clock ticks later.

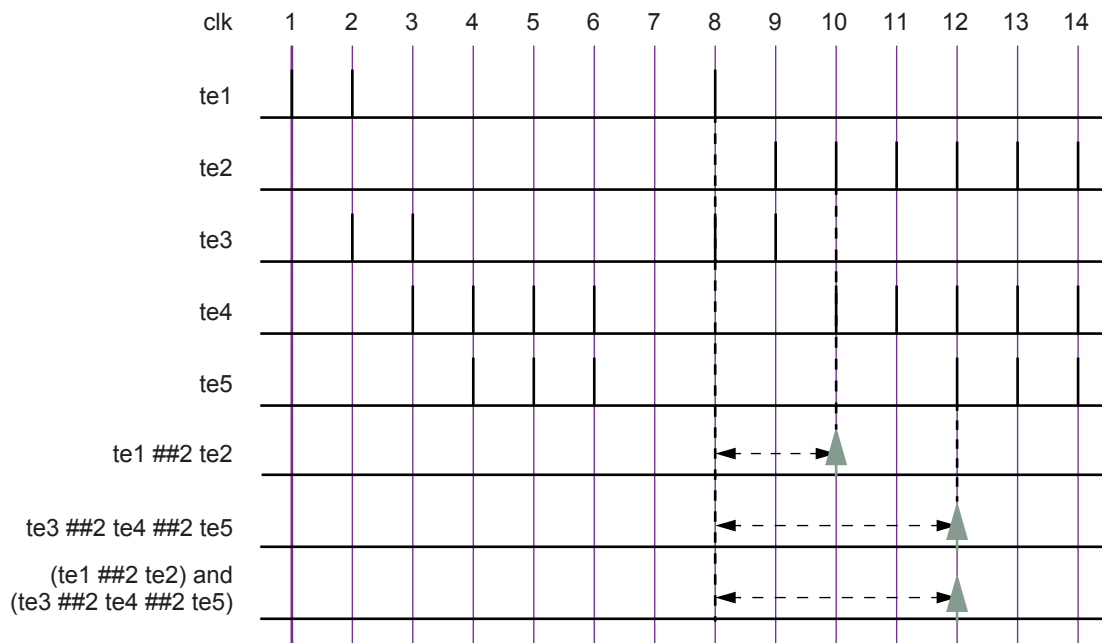

Figure 16-5—ANDing (and) two sequences

This attempt results in a match because both operand sequences match. The end times of matches for the individual sequences are clock ticks 10 and 12. The end time for the composite sequence is the later of the two end times; therefore, a match is recognized for the composite sequence at clock tick 12.

In the following example, the first operand sequence has a concatenation operator with range from 1 to 5:

`(te1 ##[1:5] te2) and (te3 ##2 te4 ##2 te5)`

The first operand sequence requires that `te1` evaluate to true and that `te2` evaluate to true 1, 2, 3, 4, or 5 clock ticks later. The second operand sequence is the same as in the previous example. To consider all possibilities of a match of the composite sequence, the following steps can be taken:

- Five threads of evaluation are started for the five possible linear sequences associated with the first sequence operand.
- The second operand sequence has only one associated linear sequence; therefore, only one thread of evaluation is started for it.
- [Figure 16-6](#) shows the evaluation attempt beginning at clock tick 8. All five linear sequences for the first operand sequence match, as shown in a time window; therefore, there are five matches of the first operand sequence, ending at clock ticks 9, 10, 11, 12, and 13, respectively. The second operand sequence matches at clock tick 12.
- Each match of the first operand sequence is combined with the single match of the second operand sequence, and the rules of the AND operation determine the end time of the resulting match of the composite sequence.

The result of this computation is five matches of the composite sequence, four of them ending at clock tick 12, and the fifth ending at clock tick 13. [Figure 16-6](#) shows the matches of the composite sequence ending at clock ticks 12 and 13.

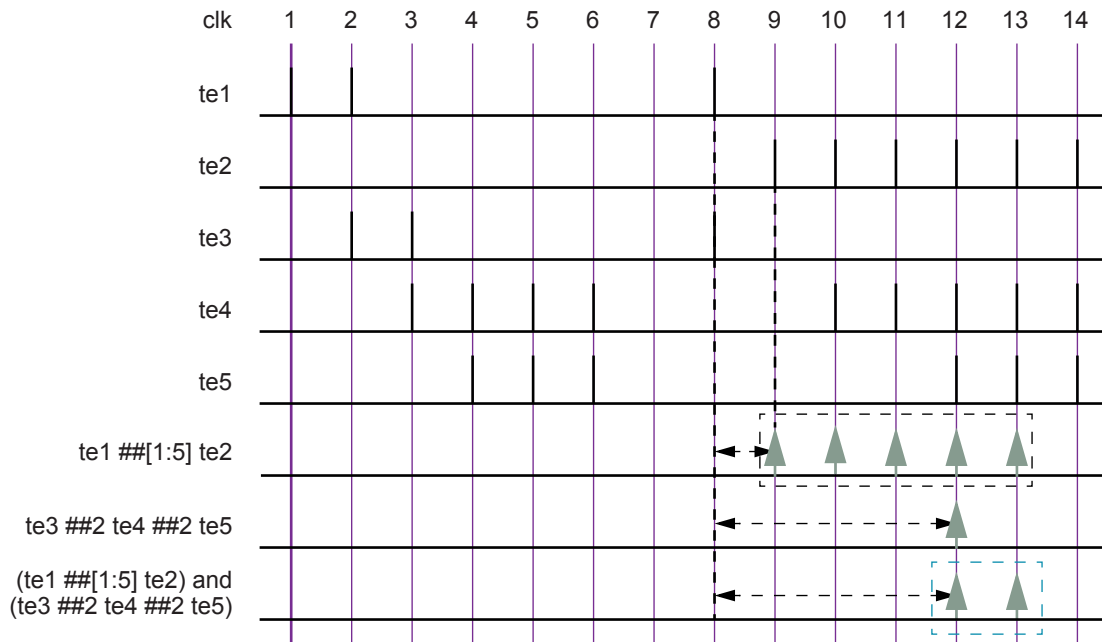

Figure 16-6—ANDing (and) two sequences, including a time range

If $te1$ and $te2$ are sampled expressions (not sequences), the sequence $(te1 \text{ and } te2)$ matches if $te1$ and $te2$ both evaluate to true.

An example is illustrated in Figure 16-7, which shows the results for attempts at every clock tick. The sequence matches at clock tick 1, 3, 8, and 14 because both $te1$ and $te2$ are simultaneously true. At all other clock ticks, match of the AND operation fails because either $te1$ or $te2$ is false.

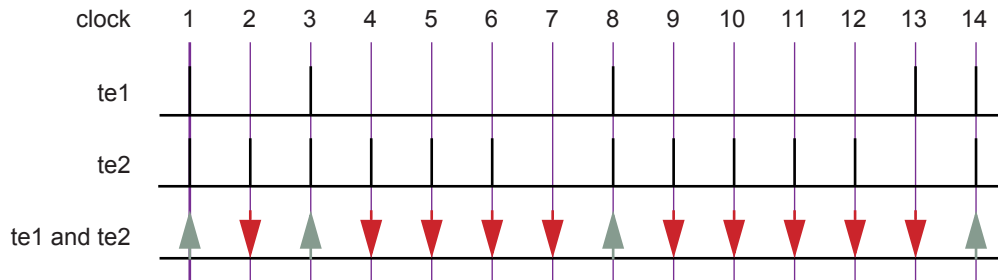

Figure 16-7—ANDing (and) two Boolean expressions

16.9.6 Intersection (AND with length restriction)

The binary operator `intersect` is used when both operand sequences are expected to match, and the end times of the operand sequences must be the same (see [Syntax 16-8](#)).

```
sequence_expr ::= // from A.2.10
...
| sequence_expr intersect sequence_expr
```

Syntax 16-8—`Intersect` operator syntax (excerpt from [Annex A](#))

The two operands of **intersect** are sequences. The requirements for match of the **intersect** operation are as follows:

- Both the operands shall match.
- The lengths of the two matches of the operand sequences shall be the same.

The additional requirement on the length of the sequences is the basic difference between **and** and **intersect**.

An attempted evaluation of an **intersect** sequence can result in multiple matches. The results of such an attempt can be computed as follows:

- Matches of the first and second operands that are of the same length are paired. Each such pair results in a match of the composite sequence, with length and end point equal to the shared length and end point of the paired matches of the operand sequences.
- If no such pair is found, then there is no match of the composite sequence.

[Figure 16-8](#) is similar to [Figure 16-6](#), except that **and** is replaced by **intersect**. In this case, unlike in [Figure 16-6](#), there is only a single match at clock tick 12.

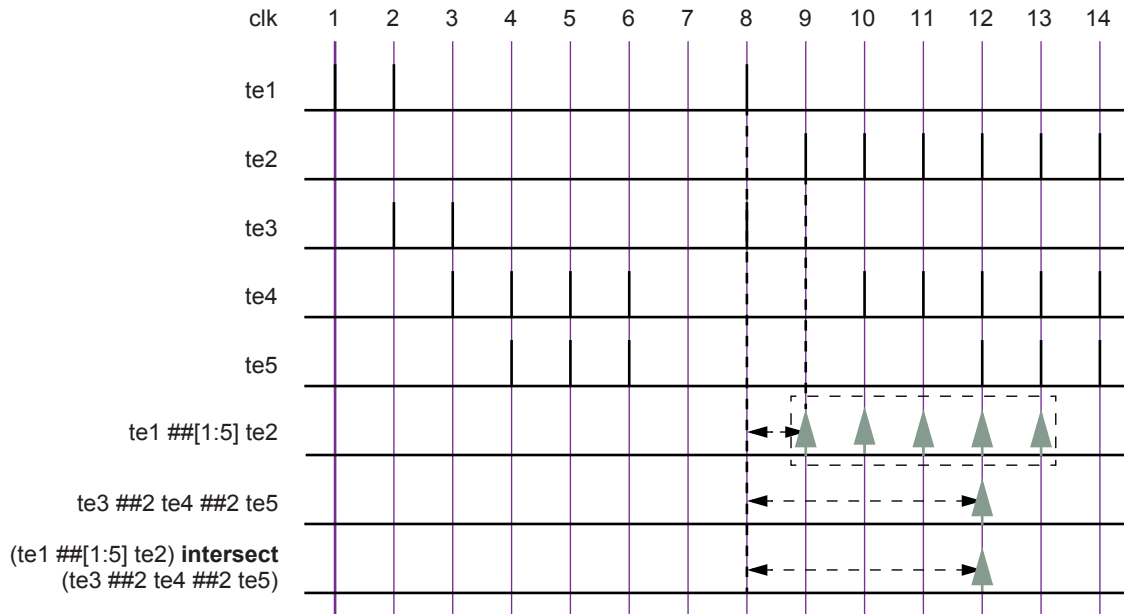

Figure 16-8—Intersecting two sequences

16.9.7 OR operation

The operator **or** is used when at least one of the two operand sequences is expected to match ([Syntax 16-9](#)).

```
sequence_expr ::= // from A.2.10
...
| sequence_expr or sequence_expr
```

Syntax 16-9—Or operator syntax (excerpt from [Annex A](#))

The two operands of **or** are sequences.

If the operands *te1* and *te2* are expressions, then

te1 or te2

matches at any clock tick on which at least one of *te1* and *te2* evaluates to true.

[Figure 16-9](#) illustrates an OR operation for which the operands *te1* and *te2* are expressions. The composite sequence does not match at clock ticks 7 and 13 because *te1* and *te2* are both false at those times. At all other clock ticks, the composite sequence matches, as at least one of the two operands evaluates to true.

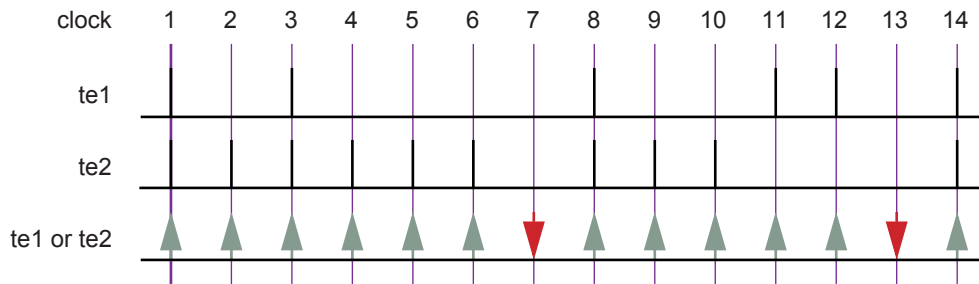

Figure 16-9—ORing (or) two Boolean expressions

When *te1* and *te2* are sequences, then the sequence

te1 or te2

matches if at least one of the two operand sequences *te1* and *te2* matches. Each match of either *te1* or *te2* constitutes a match of the composite sequence, and its end time as a match of the composite sequence is the same as its end time as a match of *te1* or of *te2*. In other words, the set of matches of *te1 or te2* is the union of the set of matches of *te1* with the set of matches of *te2*.

The following example shows a sequence with operator **or** where the two operands are sequences. [Figure 16-10](#) illustrates this example.

(*te1 ##2 te2*) **or** (*te3 ##2 te4 ##2 te5*)

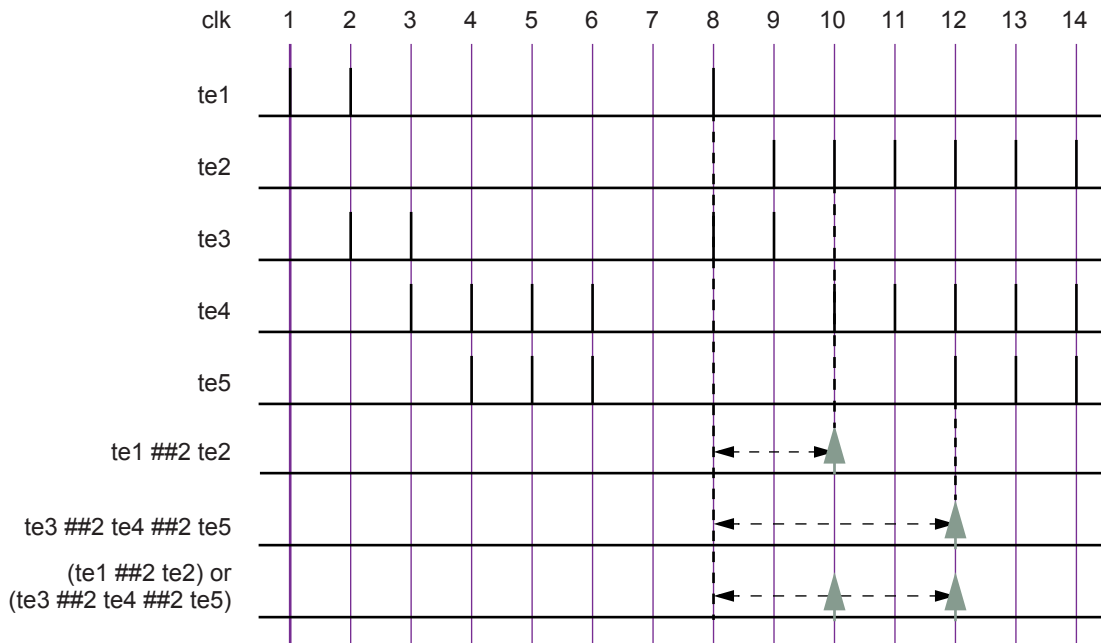

Figure 16-10—ORing (or) two sequences

Here, the two operand sequences are `(te1 ##2 te2)` and `(te3 ##2 te4 ##2 te5)`. The first sequence requires that `te1` first evaluates to true, followed by `te2` two clock ticks later. The second sequence requires that `te3` evaluates to true, followed by `te4` two clock ticks later, followed by `te5` two clock ticks later. In [Figure 16-10](#), the evaluation attempt for clock tick 8 is shown. The first sequence matches at clock tick 10, and the second sequence matches at clock tick 12. Therefore, two matches for the composite sequence are recognized.

In the following example, the first operand sequence has a concatenation operator with range from 1 to 5:

```
(te1 ##[1:5] te2) or (te3 ##2 te4 ##2 te5)
```

The first operand sequence requires that `te1` evaluate to true and that `te2` evaluate to true 1, 2, 3, 4, or 5 clock ticks later. The second operand sequence requires that `te3` evaluate to true, that `te4` evaluate to true two clock ticks later, and that `te5` evaluate to true another two clock ticks later. The composite sequence matches at any clock tick on which at least one of the operand sequences matches. As shown in [Figure 16-11](#), for the attempt at clock tick 8, the first operand sequence matches at clock ticks 9, 10, 11, 12, and 13, while the second operand matches at clock tick 12. The composite sequence, therefore, has one match at each of clock ticks 9, 10, 11, and 13 and has two matches at clock tick 12.

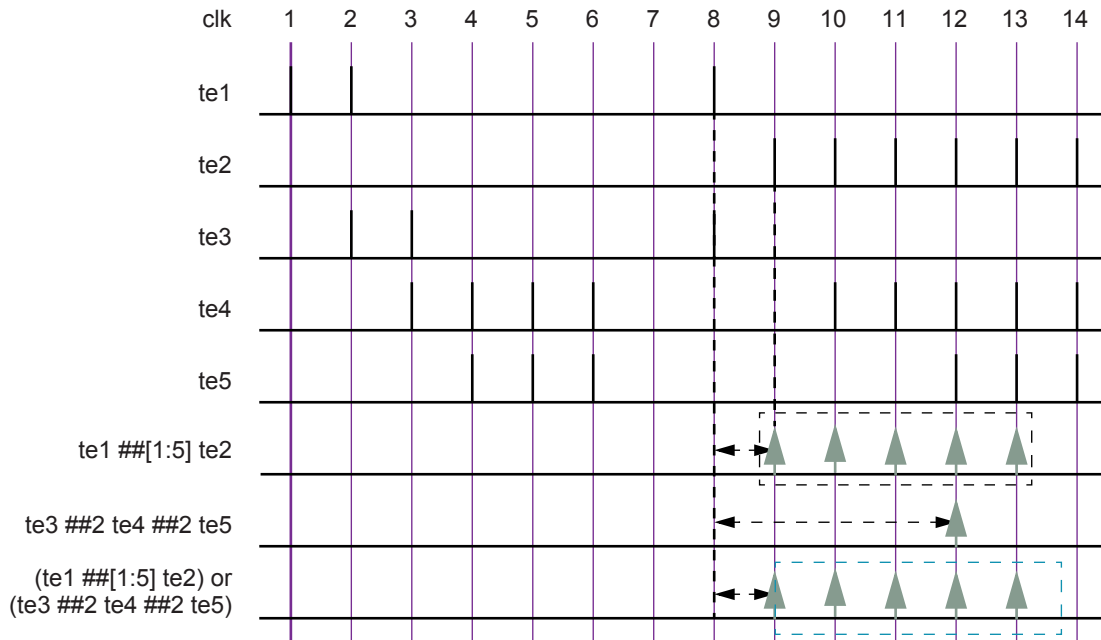

Figure 16-11—ORing (or) two sequences, including a time range

16.9.8 First_match operation

The **first_match** operator matches only the first of possibly multiple matches for an evaluation attempt of its operand sequence. This allows all subsequent matches to be discarded from consideration. In particular, when a sequence is a subsequence of a larger sequence, then applying the **first_match** operator has significant effect on the evaluation of the enclosing sequence (see [Syntax 16-10](#)).

```
sequence_expr ::= // from A.2.10
...
| first_match ( sequence_expr { , sequence_match_item } )
```

Syntax 16-10—First_match operator syntax (excerpt from [Annex A](#))

An evaluation attempt of **first_match**(seq) results in an evaluation attempt for the operand seq beginning at the same clock tick. If the evaluation attempt for seq produces no match, then the evaluation attempt for **first_match**(seq) produces no match. Otherwise, the match of seq with the earliest ending clock tick is a match of **first_match**(seq). If there are multiple matches of seq with the same ending clock tick as the earliest one, then all those matches are matches of **first_match**(seq).

The following example shows a variable delay specification:

```
sequence t1;
  te1 ## [2:5] te2;
endsequence
sequence ts1;
  first_match(te1 ## [2:5] te2);
endsequence
```

Here, `te1` and `te2` are expressions. Each attempt of sequence `t1` can result in matches for up to four of the following sequences:

```
te1 ##2 te2
te1 ##3 te2
te1 ##4 te2
te1 ##5 te2
```

However, sequence `ts1` can result in a match for only one of the above four sequences. Whichever match of the above four sequences ends first is a match of sequence `ts1`.

For example:

```
sequence t2;
  (a ##[2:3] b) or (c ##[1:2] d);
endsequence
sequence ts2;
  first_match(t2);
endsequence
```

Each attempt of sequence `t2` can result in matches for up to four of the following sequences:

```
a ##2 b
a ##3 b
c ##1 d
c ##2 d
```

Sequence `ts2` matches only the earliest ending match of these sequences. If `a`, `b`, `c`, and `d` are expressions, then it is possible to have matches ending at the same time for both.

```
a ##2 b
c ##2 d
```

If both of these sequences match and `(c ##1 d)` does not match, then evaluation of `ts2` results in these two matches.

Sequence match items can be attached to the operand sequence of the `first_match` operator. The sequence match items are placed within the same set of parentheses that enclose the operand. Thus, for example, the local variable assignment `x = e` can be attached to the first match of `seq` via

```
first_match(seq, x = e)
```

which is equivalent to the following:

```
first_match((seq, x = e))
```

See [16.10](#) and [16.11](#) for discussion of sequence match items.

16.9.9 Conditions over sequences

Sequences often occur under the assumptions of some conditions for correct behavior. A logical condition must hold true, for instance, while processing a transaction. Also, occurrence of certain values is prohibited while processing a transaction. Such situations can be expressed directly using the construct shown in [Syntax 16-11](#).

```
sequence_expr ::= //from A.2.10
...
| expression_or_dist throughout sequence_expr
```

Syntax 16-11—Throughout construct syntax (excerpt from [Annex A](#))

The construct `exp throughout seq` is an abbreviation for the following:

```
(exp) [*0:$] intersect seq
```

The composite sequence, `exp throughout seq`, matches along a finite interval of consecutive clock ticks provided `seq` matches along the interval and `exp` evaluates to true at each clock tick of the interval.

The following example is illustrated in [Figure 16-12](#).

```
sequence burst_rule1;
  @(posedge mclk)
    $fell(burst_mode) ##0
    ((!burst_mode) throughout (##2 ((trdy==0) && (irdy==0)) [*7]));
endsequence
```

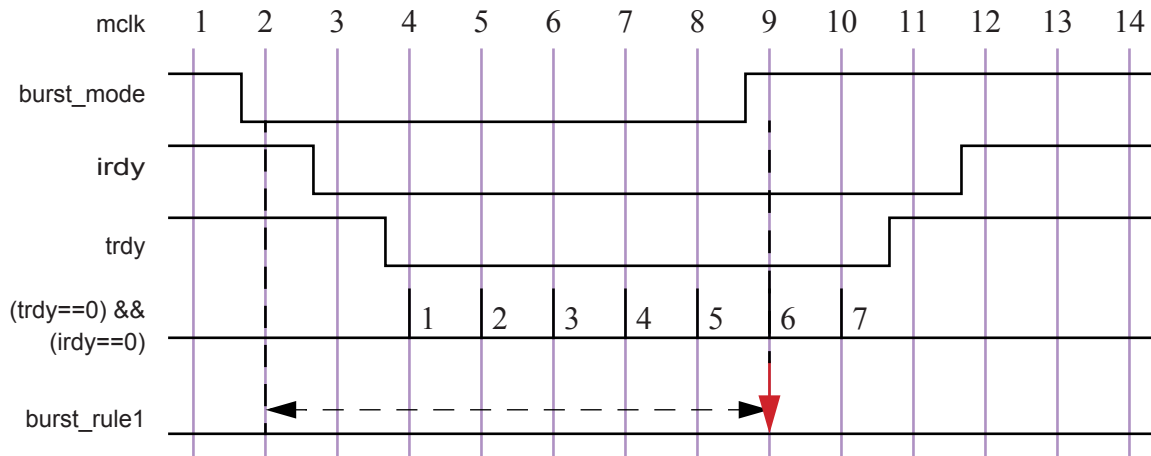

Figure 16-12—Match with throughout restriction fails

[Figure 16-13](#) illustrates the evaluation attempt for sequence `burst_rule1` beginning at clock tick 2. Because signal `burst_mode` is high at clock tick 1 and low at clock tick 2, `$fell(burst_mode)` is true at clock tick 2. To complete the match of `burst_rule1`, the value of `burst_mode` is required to be low throughout a match of the subsequence `(##2 ((trdy==0) && (irdy==0)) [*7])` beginning at clock tick 2. This subsequence matches from clock tick 2 to clock tick 10. However, at clock tick 9 `burst_mode` becomes high, thereby failing to match according to the rules for `throughout`.

If signal `burst_mode` were instead to remain low through at least clock tick 10, then there would be a match of `burst_rule1` from clock tick 2 to clock tick 10, as shown in [Figure 16-13](#).

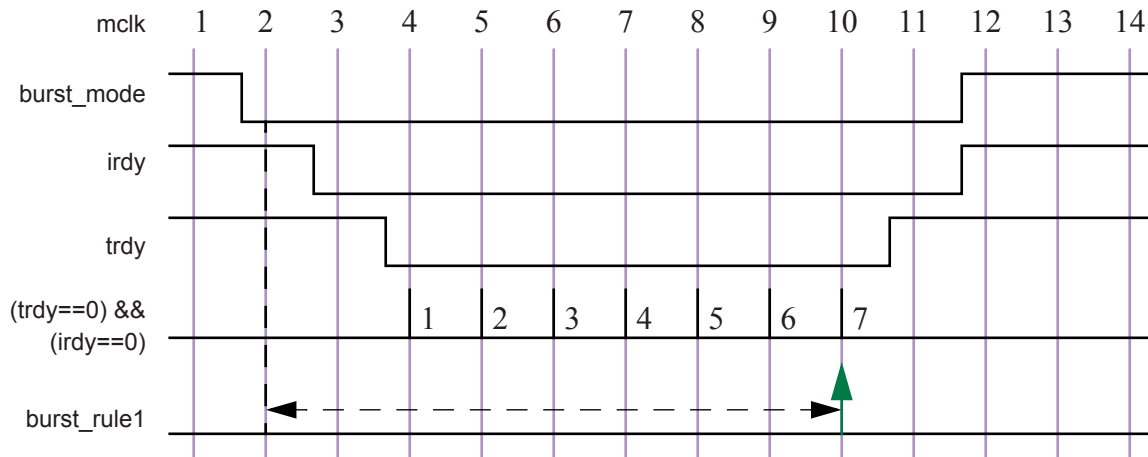

Figure 16-13—Match with throughput restriction succeeds

16.9.10 Sequence contained within another sequence

The containment of a sequence within another sequence is expressed as follows in [Syntax 16-12](#).

```
sequence_expr ::= // from A.2.10
...
| sequence_expr within sequence_expr
```

Syntax 16-12—Within construct syntax (excerpt from [Annex A](#))

The construct `seq1 within seq2` is an abbreviation for the following:

```
(1[*0:$] ##1 seq1 ##1 1[*0:$]) intersect seq2
```

The composite sequence `seq1 within seq2` matches along a finite interval of consecutive clock ticks provided `seq2` matches along the interval and `seq1` matches along some subinterval of consecutive clock ticks. In other words, the matches of `seq1` and `seq2` must satisfy the following:

- The start point of the match of `seq1` shall be no earlier than the start point of the match of `seq2`.
- The end point of the match of `seq1` shall be no later than the end point of the match of `seq2`.

For example, the sequence

```
!trdy[*7] within ($fell(irdy) ##1 !irdy[*8])
```

matches from clock tick 3 to clock tick 11 on the trace shown in [Figure 16-13](#).

16.9.11 Detecting and using end point of a sequence

There are two ways in which a complex sequence can be decomposed into simpler subsequences.

One is to instantiate a named sequence by referencing its name. Evaluation of such a reference requires the named sequence to match starting from the clock tick at which the reference is reached during the evaluation of the enclosing sequence. For example:

```

sequence s;
  a ##1 b ##1 c;
endsequence
sequence rule;
  @(posedge sysclk)
    trans ##1 start_trans ##1 s ##1 end_trans;
endsequence

```

Sequence `s` is evaluated beginning one tick after the evaluation of `start_trans` in the sequence rule.

Another way to use a sequence is to detect its end point in another sequence. The end point of a sequence is reached whenever the ending clock tick of a match of the sequence is reached, regardless of the starting clock tick of the match. The reaching of the end point can be tested by using the method `triggered`.

The syntax of the `triggered` method is as follows:

```
sequence_instance.triggered
```

`triggered` is a method on a sequence. The result of its operation is true or false. When method `triggered` is evaluated in an expression, it tests whether its operand sequence has reached its end point at that particular point in time. The result of `triggered` does not depend upon the starting point of the match of its operand sequence. An example is shown as follows:

```

sequence e1;
  @(posedge sysclk) $rose(ready) ##1 proc1 ##1 proc2 ;
endsequence
sequence rule;
  @(posedge sysclk) reset ##1 inst ##1 e1.triggered ##1 branch_back;
endsequence

```

In this example, sequence `e1` must match one clock tick after `inst`. If the method `triggered` is replaced with an instance of sequence `e1`, a match of `e1` must start one clock tick after `inst`. Notice that method `triggered` only tests for the end point of `e1` and has no bearing on the starting point of `e1.triggered` can be used on sequences that have formal arguments. For example, with the following declarations:

```

sequence e2(a,b,c);
  @(posedge sysclk) $rose(a) ##1 b ##1 c;
endsequence
sequence rule2;
  @(posedge sysclk) reset ##1 inst ##1 e2(ready,proc1,proc2).triggered
    ##1 branch_back;
endsequence

```

`rule2` is equivalent to `rule2a` as follows:

```

sequence e2_instantiated;
  e2(ready,proc1,proc2);
endsequence
sequence rule2a;
  @(posedge sysclk) reset ##1 inst ##1 e2_instantiated.triggered ##1
branch_back;
endsequence

```

There are additional restrictions on passing local variables into an instance of a sequence to which `triggered` is applied. See [16.10](#).

Method `triggered` can be used in the presence of multiple clocks. However, the ending clock of the sequence instance to which `triggered` is applied shall always be the same as the clock in the context where the application of method `triggered` appears. See [16.14.5](#).

16.10 Local variables

Data can be manipulated within named sequences (see [16.8](#)) and properties (see [16.13](#)) using dynamically created local variables. The use of a static SystemVerilog variable implies that only one copy exists. If data values need to be checked in pipelined designs, then for each quantum of data entering the pipeline, a separate variable can be used to store the predicted output of the pipeline for later comparison when the result actually exits the pipe. This storage can be built by using an array of variables arranged in a shift register to mimic the data propagating through the pipeline. However, in more complex situations where the latency of the pipe is variable and out of order, this construction could become very complex and error prone. Therefore, variables are needed that are local to and are used within a particular transaction check that can span an arbitrary interval of time and can overlap with other transaction checks. Such a variable will thus be dynamically created when needed within an instance of a sequence and removed when the end of the sequence is reached.

The dynamic creation of a local variable and its assignment is achieved by either using a local variable formal argument declaration (see [16.8.2](#), [16.13.18](#)) or using an assertion variable declaration within the declaration of a named sequence or property (see [16.13](#)). Without further specification, the term “*local variable*” shall mean either a local variable formal argument or a local variable declared in an *assertion_variable_declaration*. Without further specification, the term “*local variable initialization assignment*” shall mean either an initialization assignment to a local variable formal argument of direction **input** or **inout** of the value of the corresponding actual argument or a declaration assignment to a local variable declared in an *assertion_variable_declaration* (see [Syntax 16-13](#)).

```
assertion_variable_declaration ::= // from A.2.10
    var_data_type list_of_variable_decl_assignments ;
```

Syntax 16-13—Assertion variable declaration syntax (excerpt from [Annex A](#))

The data type of an assertion variable declaration shall be specified explicitly. The data type shall be one of the types allowed within assertions as defined in [16.6.1](#). The data type shall be followed by a comma-separated list of one or more identifiers with optional declaration assignments. A declaration assignment, if present, defines the initial value to be placed in the corresponding local variable. The initial value is defined by an expression, which need not be constant.

At the beginning of each evaluation attempt of an instance of a named sequence or property, a new copy of each of its local variables shall be created and, if present, the corresponding initialization assignment shall be performed. Initialization assignments shall be performed in the Observed region in the order that they appear in the sequence or property declaration. For the purposes of this rule, all initialization assignments to local variable formal arguments shall be performed before any initialization assignment to a local variable declared in an *assertion_variable_declaration*. Non-local variables appearing in the expression of an initialization assignment to a local variable shall be evaluated using the Preponed values from the time slot in which the evaluation attempt begins. The expression of an initialization assignment to a given local variable may refer to a previously declared local variable. In this case the previously declared local variable shall itself have an initialization assignment, and the initial value assigned to the previously declared local variable shall be used in the evaluation of the expression assigned to the given local variable. Local variables do not have default initial values. A local variable without an initialization assignment shall be unassigned at the beginning of the evaluation attempt.

For example, at the beginning of an evaluation attempt of an instance of

```
sequence s;
  logic u, v = a, w = v || b;
  ...
endsequence
```

the assignment of *a* to *v* is performed first and the assignment of *v* || *b* to *w* is performed second. The value assigned to *w* is the same as that which would result from the declaration assignment *w* = *a* || *b*. The local variable *u* is unassigned at the beginning of the evaluation attempt.

Local variables may be assigned and re-assigned within the body of the sequence or property in which they are declared.

```
sequence_expr ::= // from A.2.10
  ...
  | ( sequence_expr { , sequence_match_item } ) [ sequence_abbrev ]
  ...
sequence_match_item ::=
  operator_assignment
  | inc_or_dec_expression
  ...
```

Syntax 16-14—Variable assignment syntax (excerpt from [Annex A](#))

One or more local variables may be assigned at the end point of a syntactic subsequence by placing the subsequence, comma-separated from the list of local variable assignments, in parentheses. At the end of any non-empty match of the subsequence, the local variable assignments are performed in the order that they appear in the list. For example, if in

```
a ##1 b[->1] ##1 c[*2]
```

it is desired to assign *x* = *e* and then *y* = *x* && *f* at the match of *b*[->1], the sequence can be rewritten as

```
a ##1 (b[->1], x = e, y = x && f) ##1 c[*2]
```

A local variable may be reassigned later in the sequence or property, as in

```
a ##1 (b[->1], x = e, y = x && f) ##1 (c[*2], x &= g)
```

The subsequence to which a local variable assignment is attached shall not admit an empty match. For example, the sequence

```
a ##1 (b[*0:1], x = e) ##1 c[*2] // illegal
```

is illegal because the subsequence *b*[*0:1] can match the empty word. The sequence

```
(a ##1 b[*0:1], x = e) ##1 c[*2] // legal
```

is legal because the concatenated subsequence *a* ##1 *b*[*0:1] cannot match the empty word.

A local variable may be referenced within the sequence or property in which it is declared. The sequence or property shall assign a value to the local variable prior to the point at which the reference is made. The prior

assignment may be an initialization assignment or an assignment attached to a subsequence. There is an implicit reference associated with the use of an *inc_or_dec_operator* or an assignment operator other than “=”. Therefore, a local variable shall be assigned a value prior to being updated with an *inc_or_dec_operator* or with an assignment operator other than “=”.

Under certain circumstances, a local variable that is assigned later becomes unassigned. If a local variable does not flow out of a subsequence (see below), then the local variable shall become unassigned at the end of that subsequence, regardless of whether it was assigned a value prior to that point. The local variable shall not be referenced after the point from which it does not flow until after it has again been assigned a value. See [Annex F](#) for precise conditions defining local variable flow.

Hierarchical references to a local variable are not allowed.

As an example of local variable usage, assume a pipeline that has a fixed latency of five clock cycles. The data enter the pipe on `pipe_in` when `valid_in` is true, and the value computed by the pipeline appears five clock cycles later on the signal `pipe_out1`. The data as transformed by the pipe are predicted by a function that increments the data. The following property verifies this behavior:

```
property e;
  int x;
  (valid_in, x = pipe_in) |-> ##5 (pipe_out1 == (x+1));
endproperty
```

Property `e` is evaluated as follows:

- When `valid_in` is true, `x` is assigned the value of `pipe_in`. If five cycles later, `pipe_out1` is equal to `x+1`, then property `e` is true. Otherwise, property `e` is false.
- When `valid_in` is false, property `e` evaluates to true.

A local variable can be used to form expressions in the same way that a static variable of the same type can be used. This includes the use of local variables in expressions for bit-selects and part-selects of vectors or for indices of arrays.

Local variables may be used in sequences or properties.

```
sequence data_check;
  int x;
  a ##1 (!a, x = data_in) ##1 !b[*0:$] ##1 b && (data_out == x);
endsequence
property data_check_p
  int x;
  a ##1 (!a, x = data_in) |=> !b[*0:$] ##1 b && (data_out == x);
endproperty
```

Local variable assignments may be attached to the operand sequence of a repetition and accomplish accumulation of values.

```
sequence rep_v;
  int x = 0;
  (a[->1], x += data)[*4] ##1 b ##1 c && (data_out == x);
endsequence
```

An accumulating local variable may be used to count the number of times a condition is repeated, as in the following example:

```
sequence count_a_cycles;
```

```

int x;
($rose(a), x = 1)
##1 (a, x++)[*0:$]
##1 !a && (x <= MAX);
endsequence

```

The local variables declared within a sequence or property are not visible in the context where the sequence or property is instantiated. The following example illustrates an illegal access to local variable `v1` of sequence `sub_seq1` in sequence `seq1`.

```

sequence sub_seq1;
  int v1;
  (a ##1 !a, v1 = data_in) ##1 !b[*0:$] ##1 b && (data_out == v1);
endsequence
sequence seq1;
  c ##1 sub_seq1 ##1 (do1 == v1); // error because v1 is not visible
endsequence

```

It can be useful to assign a value to a local variable within an instance of a named sequence and reference the local variable in the instantiating context at or after the completion of a match of the instance. This capability is supported under the following conditions:

- The local variable shall be declared outside the named sequence, and its scope shall include both the instance of the named sequence and the desired reference in the instantiating context.
- The local variable shall be passed as an entire actual argument in the list of arguments of the instance of the named sequence.
- The corresponding formal argument shall be untyped.

The named sequence may specify assignments to the formal argument in one or more *sequence_match_items*.

The following example illustrates this usage:

```

sequence sub_seq2(lv);
  (a ##1 !a, lv = data_in) ##1 !b[*0:$] ##1 b && (data_out == lv);
endsequence
sequence seq2;
  int v1;
  c ##1 sub_seq2(v1) // v1 is bound to lv
  ##1 (do1 == v1); // v1 holds the value that was assigned to lv
endsequence

```

An alternative way to achieve a similar capability is by using local variable formal arguments (see [16.8.2](#)).

Local variables can be passed into an instance of a named sequence to which `triggered` is applied and accessed in a similar manner. For example:

```

sequence seq2a;
  int v1; c ##1 sub_seq2(v1).triggered ##1 (do1 == v1); // v1 is now bound
  to lv
endsequence

```

There are additional restrictions when passing local variables into an instance of a named sequence to which `triggered` is applied:

- Local variables can be passed in only as entire actual arguments, not as proper subexpressions of actual arguments.
- In the declaration of the named sequence, the formal argument to which the local variable is bound shall not be referenced before it is assigned.

The second restriction is met by `sub_seq2` because the assignment `lv = data_in` occurs before the reference to `lv` in `data_out == lv`.

If a local variable is assigned before being passed into an instance of a named sequence to which `triggered` is applied, then the restrictions prevent this assigned value from being visible within the named sequence. The restrictions are important because the use of `triggered` means that there is no guaranteed relationship between the point in time at which the local variable is assigned outside the named sequence and the beginning of the match of the instance.

A local variable that is passed in as actual argument to an instance of a named sequence to which `triggered` is applied will flow out of the application of `triggered` to that instance provided both of the following conditions are met:

- The local variable flows out of the end of the named sequence instance, as defined by the local variable flow rules for sequences. (See below and [Annex F](#).)
- The application of `triggered` to this instance is a maximal Boolean expression. In other words, the application of `triggered` cannot have negation or any other expression operator applied to it.

Both conditions are satisfied by `sub_seq2` and `seq2a`. Thus, in `seq2a`, the value in `v1` in the comparison `do1 == v1` is the value assigned to `lv` in `sub_seq2` by the assignment `lv = data_in`. However, in

```
sequence seq2b;
  int v1; c ##1 !sub_seq2(v1).triggered ##1 (do1 == v1); // v1 unassigned
endsequence
```

the second condition is violated because of the negation applied to `sub_seq2(v1).triggered`. Therefore, `v1` does not flow out of the application of `triggered` to this instance, and the reference to `v1` in `do1 == v1` is to an unassigned variable.

In a single cycle, there can be multiple matches of a sequence instance to which `triggered` is applied, and these matches can have different valuations of the local variables. The multiple matches are treated semantically the same way as matching both disjuncts of an `or` (see below). In other words, the thread evaluating the instance to which `triggered` is applied will fork to account for such distinct local variable valuations.

When a local variable is a formal argument of a sequence declaration, it is illegal to declare the variable, as shown in the following example:

```
sequence sub_seq3(lv);
  int lv; // illegal because lv is a formal argument
  (a ##1 !a, lv = data_in) ##1 !b[*0:$] ##1 b && (data_out == lv);
endsequence
```

There are special considerations when using local variables in sequences involving the branching operators `or`, `and`, and `intersect`. The evaluation of a composite sequence constructed from one of these operators can be thought of as forking two threads to evaluate the operand sequences in parallel. A local variable may have been assigned a value before the start of the evaluation of the composite sequence, either from an initialization assignment or from an assignment attached to a preceding subsequence. Such a local variable is said to flow in to each of the operand sequences. The local variable may be assigned or reassigned in one or both of the operand sequences. In general, there is no guarantee that evaluation of the two threads results

in consistent values for the local variable, or even that there is a consistent view of whether the local variable has been assigned a value. Therefore, the values assigned to the local variable before and during the evaluation of the composite sequence are not always allowed to be visible after the evaluation of the composite sequence.

In some cases, inconsistency in the view of the local variable's value does not matter, while in others it does. Precise conditions are given in [Annex F](#) to define static (i.e., compile-time computable) conditions under which a sufficiently consistent view of the local variable's value after the evaluation of the composite sequence is provided. If these conditions are satisfied, then the local variable is said to flow out of the composite sequence. Otherwise, the local variable shall become unassigned at the end of the composite sequence. An intuitive description of the conditions for local variable flow follows:

- a) Variables assigned on parallel threads cannot be accessed in sibling threads. For example:

```
sequence s4;
  int x;
  (a ##1 (b, x = data) ##1 c) or (d ##1 (e==x)); // illegal
endsequence
```

- b) In the case of **or**, a local variable flows out of the composite sequence if, and only if, it flows out of each of the operand sequences. If the local variable is not assigned before the start of the composite sequence and it is assigned in only one of the operand sequences, then it does not flow out of the composite sequence.
- c) Each thread for an operand of an **or** that matches its operand sequence continues as a separate thread, carrying with it its own latest assignments to the local variables that flow out of the composite sequence. These threads do not have to have consistent valuations for the local variables. For example:

```
sequence s5;
  int x,y;
  ((a ##1 (b, x = data, y = data1) ##1 c)
   or (d ##1 (`true, x = data) ##0 (e==x))) ##1 (y==data2);
  // illegal because y is not in the intersection
endsequence
sequence s6;
  int x,y;
  ((a ##1 (b, x = data, y = data1) ##1 c)
   or (d ##1 (`true, x = data) ##0 (e==x))) ##1 (x==data2);
  // legal because x is in the intersection
endsequence
```

- d) In the case of **and** and **intersect**, a local variable that flows out of at least one operand shall flow out of the composite sequence unless it is blocked. A local variable is blocked from flowing out of the composite sequence if either of the following statements applies:
- 1) The local variable is assigned in and flows out of each operand of the composite sequence, or
 - 2) The local variable is blocked from flowing out of at least one of the operand sequences.

The value of a local variable that flows out of the composite sequence is the latest assigned value. The threads for the two operands are merged into one at completion of evaluation of the composite sequence.

```
sequence s7;
  int x,y;
  ((a ##1 (b, x = data, y = data1) ##1 c)
   and (d ##1 (`true, x = data) ##0 (e==x))) ##1 (x==data2);
  // illegal because x is common to both threads
endsequence
sequence s8;
  int x,y;
```

```

(a ##1 (b, x = data, y = data1) ##1 c)
  and (d ##1 (`true, x = data) ##0 (e==x)) ##1 (y==data2);
// legal because y is in the difference
endsequence

```

16.11 Calling subroutines on match of a sequence

Tasks, task methods, void functions, void function methods, and system tasks can be called at the end of a successful non-empty match of a sequence. The subroutine calls, like local variable assignments, appear in the comma-separated list that follows the sequence. The subroutine calls are said to be attached to the sequence. It shall be an error to attach a subroutine call or any *sequence match item* to a sequence that admits an empty match. The sequence and the list that follows are enclosed in parentheses (see [Syntax 16-15](#)).

```

sequence_expr ::= //from A.2.10
...
| ( sequence_expr { , sequence_match_item } ) [ sequence_abbrev ]
...
sequence_match_item ::=
  operator_assignment
| inc_or_dec_expression
| subroutine_call

```

Syntax 16-15—Subroutine call in sequence syntax (excerpt from [Annex A](#))

For example:

```

sequence s1;
  logic v, w;
  (a, v = e) ##1
  (b[->1], w = f, $display("b after a with v = %h, w = %h\n", v, w));
endsequence

```

defines a sequence `s1` that matches at the first occurrence of `b` strictly after an occurrence of `a`. At the match, the system task `$display` is executed to write a message that announces the match and shows the values assigned to the local variables `v` and `w`.

All subroutine calls attached to a sequence are executed at every successful match of the sequence. For each successful match, the attached calls are executed in the order they appear in the list. Assertion evaluation does not wait on or receive data back from any attached subroutine. The subroutines are scheduled in the Reactive region, like an action block.

Each argument of a subroutine call attached to a sequence shall either be passed by value as an input or be passed by reference (either `ref` or `const ref`; see [13.5.2](#)). Actual argument expressions that are passed by value use sampled values of the underlying variables and are consistent with the variable values used to evaluate the sequence match. The variable passed by value as an input shall be of a type allowed in [16.6.1](#). An automatic variable shall not be passed as an argument to a subroutine call either as input or `ref` type. An automatic variable may be used as a constant input for a subroutine call from an assertion statement in procedural code (see [16.15.5](#)). The rules for passing elements of dynamic arrays, queues and associative arrays as `ref` arguments are described in [13.5.2](#).

Local variables can be passed into subroutine calls attached to a sequence. Any local variable that flows out of the sequence or that is assigned in the list following the sequence, but before the subroutine call, can be used in an actual argument expression for the call. If a local variable appears in an actual argument expression, then that argument shall be passed by value.

16.12 System functions

Assertions are commonly used to evaluate certain specific characteristics of a design implementation, such as whether a particular signal is “one-hot”. The following system functions are included to facilitate such common assertion functionality:

- `$onehot (<expression>)` returns true if only 1 bit of the expression is high.
- `$onehot0 (<expression>)` returns true if at most 1 bit of the expression is high.
- `$isunknown (<expression>)` returns true if any bit of the expression is x or z. This is equivalent to `^(<expression>) === 1'bx`.

All of the above system functions have a return type of **bit**. A return value of 1'b1 indicates true, and a return value of 1'b0 indicates false.

Another useful function provided for the Boolean expression is `$countones`, to count the number of ones in a bit vector expression.

```
$countones ( expression)
```

A bit with value X or Z is not counted towards the number of ones.

16.13 Declaring properties

A property defines a behavior of the design. A named property may be used for verification as an assumption, an obligation, or a coverage specification. In order to use the behavior for verification, an **assert**, **assume**, or **cover** statement must be used. A property declaration by itself does not produce any result.

A named **property** may be declared in any of the following:

- A module
- An interface
- A program
- A **clocking** block
- A package
- A compilation-unit scope
- A generate block
- A checker

To declare a named property, the **property** construct is used as shown in [Syntax 16-16](#).

```
assertion_item_declaration ::=                               //from A.2.10  
    property_declaration  
    ...  
property_declaration ::=  
    property property_identifier [ ( [ property_port_list ] ) ] ;
```

```

    { assertion_variable_declaration }
    property_statement_spec
endproperty [ : property_identifier ]
property_port_list ::=
    property_port_item { , property_port_item }
property_port_item ::=
    { attribute_instance } [ local [ property_lvar_port_direction ] ] property_formal_type
    port_identifier {variable_dimension} [ = property_actual_arg ]
property_lvar_port_direction ::= input
property_formal_type ::=
    sequence_formal_type
    | property
property_spec ::=
    [ clocking_event ] [ disable iff ( expression_or_dist ) ] property_expr
property_statement_spec ::=
    [ clocking_event ] [ disable iff ( expression_or_dist ) ] property_statement
property_statement ::=
    property_expr ;
    | case ( expression_or_dist ) property_case_item { property_case_item } endcase
    | if ( expression_or_dist ) property_expr [ else property_expr ]
property_case_item ::=
    expression_or_dist { , expression_or_dist } : property_statement
    | default [ : ] property_statement
property_expr ::=
    sequence_expr
    | strong ( sequence_expr )
    | weak ( sequence_expr )
    | ( property_expr )
    | not property_expr
    | property_expr or property_expr
    | property_expr and property_expr
    | sequence_expr -> property_expr
    | sequence_expr ==> property_expr
    | property_statement
    | sequence_expr ## property_expr
    | sequence_expr ## property_expr
    | nexttime property_expr
    | nexttime [ constant_expression ] property_expr
    | s_nexttime property_expr
    | s_nexttime [ constant_expression ] property_expr
    | always property_expr
    | always [ cycle_delay_const_range_expression ] property_expr
    | s_always [ constant_range ] property_expr
    | s_eventually property_expr
    | eventually [ constant_range ] property_expr
    | s_eventually [ cycle_delay_const_range_expression ] property_expr
    | property_expr until property_expr
    | property_expr s_until property_expr
    | property_expr until_with property_expr
    | property_expr s_until_with property_expr
    | property_expr implies property_expr

```



```

| property_expr iff property_expr
| accept_on ( expression_or_dist ) property_expr
| reject_on ( expression_or_dist ) property_expr
| sync_accept_on ( expression_or_dist ) property_expr
| sync_reject_on ( expression_or_dist ) property_expr
| property_instance
| clocking_event property_expr
assertion_variable_declaration ::=
    var_data_type list_of_variable_decl_assignments ;
property_instance ::=
    ps_or_hierarchical_property_identifier [ ( [ property_list_of_arguments ] ) ]
property_list_of_arguments ::=
    [property_actual_arg] { , [property_actual_arg] } { , . identifier ( [property_actual_arg] ) }
    | . identifier ( [property_actual_arg] ) { , . identifier ( [property_actual_arg] ) }
property_actual_arg ::=
    property_expr
    | sequence_actual_arg

```

Syntax 16-16—Property construct syntax (excerpt from [Annex A](#))

A named property may be declared with formal arguments in the optional *property_port_list*.

Except as described below, in [16.13.18](#), [16.13.19](#), and [16.13.17](#), the rules for declaring formal arguments and default actual arguments in named properties and for instantiating named properties with actual arguments are the same as those for named sequences as described in [16.8](#), [16.8.1](#), and [16.8.2](#).

Rules particular to the specification and use of typed formal arguments in named properties are discussed in [16.13.18](#).

Rules particular to the specification and use of local variable formal arguments in named properties are discussed in [16.13.19](#).

A formal argument may be referenced in the body *property_spec* of the declaration of the named property. A reference to a formal argument may be written in place of various syntactic entities, including, in addition to those listed in [16.8](#), the following:

- *property_expr*
- *property_spec*

A named property may be instantiated prior to its declaration. A named property may be instantiated anywhere a *property_spec* may be written. A named property may be instantiated in a place where a *property_expr* may be written provided the instance does not produce an illegal **disable iff** clause (see below). There may be cyclic dependencies among named properties resulting from their instantiations. A cyclic dependency among named properties results if, and only if, there is a cycle in the directed graph whose nodes are the named properties and whose edges are defined by the following rule: there is a directed edge from one named property to a second named property if, and only if, either the first named property instantiates the second named property within its declaration, including an instance within the declaration of a default actual argument, or there is an instance of the first named property that instantiates the second named property within an actual argument. Named properties with such cyclic dependencies are called *recursive* and are discussed in [16.13.17](#).

If \$ is an actual argument to an instance of a named property, then the corresponding formal argument shall be untyped and each of its references either shall be an upper bound in a

cycle_delay_const_range_expression or shall itself be an actual argument in an instance of a named sequence or property.

The behavior and semantics of an instance of a nonrecursive named property are the same as those of the flattened property that is obtained from the body of the declaration of the named property by the rewriting algorithm defined in [F.4.1](#). The rewriting algorithm substitutes actual arguments for references to the corresponding formal arguments in the body of the declaration of the named property. The rewriting algorithm does not itself account for name resolution and assumes that names have been resolved prior to the substitution of actual arguments. If the flattened property is not legal, then the instance is not legal and there shall be an error.

The result of property evaluation is either true or false. Properties may be built from other properties or sequences using instantiation, and the operators described in the following subclauses.

[Table 16-3](#) lists the sequence and property operators from highest to lowest precedence and shows the associativity of the non-unary operators. The precedence for the strong and weak sequence operators is not defined because these operators require parentheses.

Table 16-3—Sequence and property operator precedence and associativity

Sequence operators	Property operators	Associativity
[*], [=], [->]		—
##		Left
throughout		Right
within		Left
intersect		Left
	not, nexttime, s_nexttime	—
and	and	Left
or	or	Left
	iff	Right
	until, s_until, until_with, s_until_with, implies	Right
	->, =>, #-#, #=#	Right
	always, s_always, eventually, s_eventually, if-else, accept_on, reject_on, sync_accept_on, sync_reject_on	—

A **disable iff** clause can be attached to a *property_expr* to yield a *property_spec*.

disable iff (expression_or_dist) *property_expr*

The expression of the **disable iff** is called the *disable condition*. The **disable iff** clause allows preemptive resets to be specified. For an evaluation of the *property_spec*, there is an evaluation of the underlying *property_expr*. If prior to the completion of that evaluation the disable condition becomes true, then the overall evaluation of the property results in disabled. A property has disabled evaluation if it was preempted due to a **disable iff** condition. A disabled evaluation of a property does not result in success

or failure. Otherwise, the evaluation of the *property_spec* is the same as that of the *property_expr*. The disable condition is tested independently for different evaluation attempts of the *property_spec*. The values of variables used in the disable condition are those in the current simulation cycle, i.e., not sampled. The expression may contain a reference to an end point of a sequence by using the method *triggered* of that sequence. The disable conditions shall not contain any reference to local variables or the sequence method *matched*. If a sampled value function other than `$sampled` is used in the disable condition, the sampling clock shall be explicitly specified in its actual argument list as described in [16.9.3](#). Nesting of **disable iff** clauses, explicitly or through property instantiations, is not allowed.

16.13.1 Sequence property

Sequence properties have three forms: *sequence_expr*, **weak**(*sequence_expr*), and **strong**(*sequence_expr*). The **strong** and **weak** operators are called *sequence operators*. **strong**(*sequence_expr*) evaluates to true if, and only if, there is a nonempty match of the *sequence_expr*. **weak**(*sequence_expr*) evaluates to true if, and only if, there is no finite prefix that witnesses inability to match the *sequence_expr*. The *sequence_expr* of a sequential property shall not admit an empty match.

If the **strong** or **weak** operator is omitted, then the evaluation of the *sequence_expr* depends on the assertion statement in which it is used. If the assertion statement is **assert property** or **assume property**, then the *sequence_expr* is evaluated as **weak**(*sequence_expr*). Otherwise, the *sequence_expr* is evaluated as **strong**(*sequence_expr*).

NOTE—The IEEE Std 1800-2009 semantics for a *sequence_expr* definition is not backward compatible with IEEE Std 1800-2005. The IEEE Std 1800-2009 equivalent to a *sequence_expr* as defined in IEEE Std 1800-2005 is **strong**(*sequence_expr*).

Since only one match of a *sequence_expr* is needed for **strong**(*sequence_expr*) to hold, a property of the form **strong**(*sequence_expr*) evaluates to true if, and only if, the property **strong**(**first_match**(*sequence_expr*)) evaluates to true.

Similarly, a property of the form **weak**(*sequence_expr*) evaluates to true if, and only if, the property **weak**(**first_match**(*sequence_expr*)) evaluates to true. This is because a prefix witnesses inability to match *sequence_expr* if, and only if, it witnesses inability to match **first_match**(*sequence_expr*).

The following examples illustrate the sequential property forms:

```

property p3;
  b ##1 c;
endproperty

c1: cover property (@(posedge clk) a #-# p3);
a1: assert property (@(posedge clk) a |-> p3);

```

The sequential property *p3* is interpreted as strong in the cover property *c1*. An evaluation attempt of *c1* returns true if, and only if, *a* is true at the tick of **posedge** *clk* at which the attempt begins and both of the following conditions are satisfied:

- *b* is true at the tick of **posedge** *clk* at which the attempt begins.
- There exists a subsequent tick of **posedge** *clk* and *c* is true at the first such tick.

The sequential property *p3* is interpreted as weak in the **assert property** *a1*. An evaluation attempt of *a1* returns true if, and only if, either *a* is false at the tick of **posedge** *clk* at which the attempt begins or both of the following conditions are satisfied:

- *b* is true at the tick of **posedge** *clk* at which the attempt begins.
- If there exists a subsequent tick of **posedge** *clk*, then *c* is true at the first such tick.

16.13.2 Negation property

A property is a *negation* if it has the form `not property_expr`. For each evaluation attempt of the property, there is an evaluation attempt of `property_expr`. The keyword `not` states that the evaluation of the property returns the opposite of the evaluation of the underlying `property_expr`. Thus, if `property_expr` evaluates to true, then `not property_expr` evaluates to false; and if `property_expr` evaluates to false, then `not property_expr` evaluates to true.

The `not` operator switches the strength of a property. In particular, one should be careful when negating a sequence. For example, consider the following assertion:

```
a1: assert property (@clk not a ##1 b);
```

Since the sequential property `a ##1 b` is used in an assertion, it is weak. This means that if `clk` stops ticking and `a` holds at the last tick of `clk`, the weak sequential property `a ##1 b` will also hold beginning at that tick, and so the assertion `a1` will fail. In this case it is more reasonable to use:

```
a2: assert property (@clk not strong(a ##1 b));
```

16.13.3 Disjunction property

A property is a *disjunction* if it has the following form:

```
property_expr or property_expr
```

The property evaluates to true if, and only if, at least one of `property_expr1` and `property_expr2` evaluates to true.

16.13.4 Conjunction property

A property is a *conjunction* if it has the following form:

```
property_expr and property_expr
```

The property evaluates to true if, and only if, both `property_expr1` and `property_expr2` evaluate to true.

16.13.5 If-else property

A property is an *if-else* if it has either the following form:

```
if ( expression_or_dist ) property_expr
```

or the following form:

```
if ( expression_or_dist ) property_expr else property_expr
```

A property of the first form evaluates to true if, and only if, either `expression_or_dist` evaluates to false or `property_expr` evaluates to true. A property of the second form evaluates to true if, and only if, either `expression_or_dist` evaluates to true and `property_expr1` evaluates to true or `expression_or_dist` evaluates to false and `property_expr2` evaluates to true.

16.13.6 Implication

The implication construct specifies that the checking of a property is performed conditionally on the match of a sequential antecedent (see [Syntax 16-17](#)).

```
property_expr ::= //from A.2.10
...
| sequence_expr |-> property_expr
| sequence_expr |=> property_expr
```

Syntax 16-17—Implication syntax (excerpt from [Annex A](#))

This construct is used to precondition monitoring of a property expression and is allowed at the property level. The result of the implication is either true or false. The left-hand operand *sequence_expr* is called the *antecedent*, while the right-hand operand *property_expr* is called the *consequent*.

The following points should be noted for |-> implication:

- From a given start point, the antecedent *sequence_expr* can have zero, one, or more than one successful match.
- If there is no match of the antecedent *sequence_expr* from a given start point, then evaluation of the implication from that start point succeeds and returns true.
- For each successful match of the antecedent *sequence_expr*, the consequent *property_expr* is separately evaluated. The end point of the match of the antecedent *sequence_expr* is the start point of the evaluation of the consequent *property_expr*.
- From a given start point, evaluation of the implication succeeds and returns true if, and only if, for every match of the antecedent *sequence_expr* beginning at the start point, the evaluation of the consequent *property_expr* beginning at the end point of the match succeeds and returns true.

Two forms of implication are provided: overlapped using operator |-> and nonoverlapped using operator |=>. For overlapped implication, if there is a match for the antecedent *sequence_expr*, then the end point of the match is the start point of the evaluation of the consequent *property_expr*. For nonoverlapped implication, the start point of the evaluation of the consequent *property_expr* is the clock tick after the end point of the match. Therefore,

```
sequence_expr |=> property_expr
```

is equivalent to the following:

```
sequence_expr ##1 `true |-> property_expr
```

The use of implication when multiclock sequences and properties are involved is explained in [16.14](#).

The following example illustrates a bus operation for data transfer from a master to a target device. When the bus enters a data transfer phase, multiple data phases can occur to transfer a block of data. During the data transfer phase, a data phase completes on any rising clock edge on which *irdy* is asserted and either *trdy* or *stop* is asserted. In this example, an asserted signal implies a value of low. The end of a data phase can be expressed as follows:

```
property data_end;
    @(posedge mclk)
    data_phase |-> ((irdy==0) && ($fell(trdy) || $fell(stop))) ;
endproperty
```

Each time a data phase is true, a match for *data_phase* is recognized. The attempt at clock tick 6 is illustrated in [Figure 16-14](#). The values shown for the signals are the sampled values with respect to the clock. At clock tick 6, *data_end* is true because *stop* gets asserted while *irdy* is asserted.

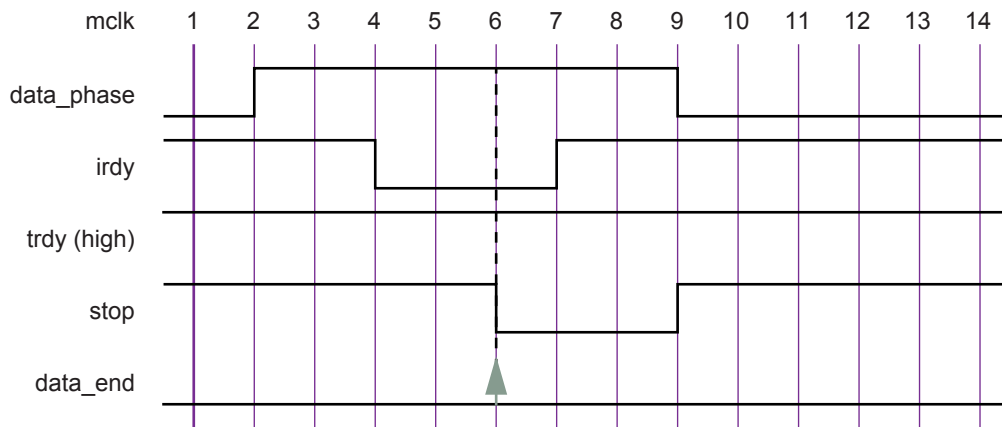

Figure 16-14—Conditional sequence matching

In another example, `data_end_exp` is used to verify that `frame` is deasserted (value high) within two clock ticks after `data_end_exp` occurs. Further, it is also required that `irdy` is deasserted (value high) one clock tick after `frame` is deasserted.

A property written to express this condition is as follows:

```

`define data_end_exp (data_phase && ((irdy==0)&&($fell(trdy)||$fell(stop)))
property data_end_rule1;
    @(posedge mclk)
    `data_end_exp |-> ##[1:2] $rose(frame) ##1 $rose(irdy);
endproperty

```

Property `data_end_rule1` first evaluates `data_end_exp` at every clock tick to test if its value is true. If the value is false, then that particular attempt to evaluate `data_end_rule1` is considered true. Otherwise, the following sequence is evaluated:

```
##[1:2] $rose(frame) ##1 $rose(irdy)
```

specifies looking for the rising edge of `frame` within two clock ticks in the future. After `frame` toggles high, `irdy` must also toggle high after one clock tick. This is illustrated in [Figure 16-15](#) for the evaluation attempt at clock tick 6. `data_end_exp` is acknowledged at clock tick 6. Next, `frame` toggles high at clock tick 7. Because this falls within the timing constraint imposed by `[1:2]`, it satisfies the sequence and continues to evaluate further. At clock tick 8, `irdy` is evaluated. Signal `irdy` transitions to high at clock tick 8, matching the sequence specification completely for the attempt that began at clock tick 6.

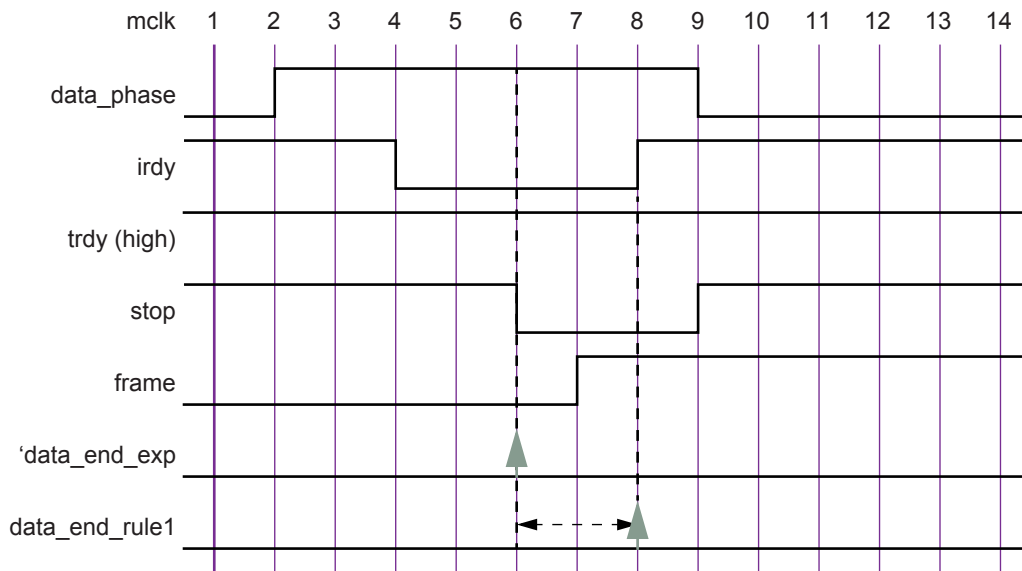

Figure 16-15—Conditional sequences

Generally, assertions are associated with preconditions so that the checking is performed only under certain specified conditions. As seen from the previous example, the `|->` operator provides this capability to specify preconditions with sequences that must be satisfied before evaluating their consequent properties. The next example modifies the preceding example to see the effect on the results of the assertion by removing the precondition for the consequent. This is shown below and illustrated in [Figure 16-16](#).

```
property data_end_rule2;
    @(posedge mclk) ##[1:2] $rose(frame) ##1 $rose(irdy);
endproperty
```

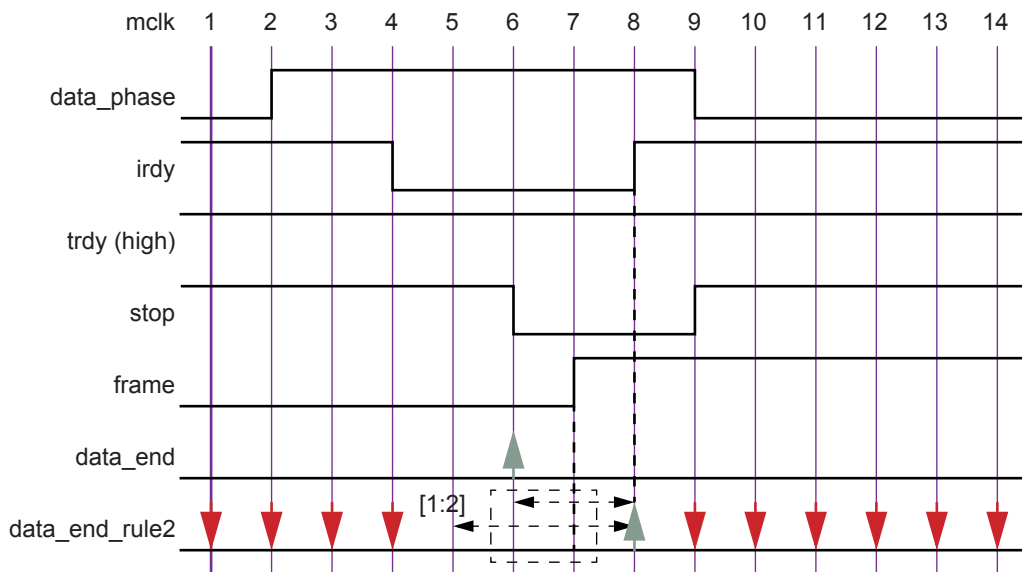

Figure 16-16—Results without the condition

The property is evaluated at every clock tick. For the evaluation at clock tick 1, the rising edge of signal `frame` does not occur at clock tick 2 or 3; therefore, the property fails at clock tick 1. Similarly, there is a failure at clock ticks 2, 3, and 4. For attempts starting at clock ticks 5 and 6, the rising edge of signal `frame` at clock tick 7 allows checking further. At clock tick 8, the sequences complete according to the specification, resulting in a match for attempts starting at clock ticks 5 and 6. All later attempts to match the sequence fail because `$rose(frame)` does not occur again.

[Figure 16-16](#) shows that removing the precondition of checking ``data_end_exp` from the assertion causes failures that are not relevant to the verification objective. It is important from the validation standpoint to determine these preconditions and use them to filter out inappropriate or extraneous situations.

An example of implication where the antecedent is a sequence follows:

```
(a ##1 b ##1 c) |-> (d ##1 e)
```

If the sequence `(a ##1 b ##1 c)` matches, then the sequence `(d ##1 e)` must also match. On the other hand, if the sequence `(a ##1 b ##1 c)` does not match, then the result is true.

Another example of implication is as follows:

```
property p16;
  (write_en & data_valid) ##0
  (write_en && (retire_address[0:4]==addr)) [*2] |->
  ##[3:8] write_en && !data_valid && (write_address[0:4]==addr);
endproperty
```

This property can be coded alternatively as a nested implication:

```
property p16_nested;
  (write_en & data_valid) |->
  (write_en && (retire_address[0:4]==addr)) [*2] |->
  ##[3:8] write_en && !data_valid && (write_address[0:4]==addr);
endproperty
```

Multiclock sequence implication is explained in [16.14](#).

16.13.7 Implies and iff properties

A property is an *implies* if it has the following form:

```
property_expr1 implies property_expr2
```

A property of this form evaluates to true if, and only if, either *property_expr1* evaluates to false or *property_expr2* evaluates to true.

A property is an *iff* if it has the following form:

```
property_expr1 iff property_expr2
```

A property of this form evaluates to true if, and only if, either both *property_expr1* evaluates to false and *property_expr2* evaluates to false or both *property_expr1* evaluates to true and *property_expr2* evaluates to true.

16.13.8 Property instantiation

An instance of a named property can be used as a *property_expr* or *property_spec*. In general, the instance is legal provided the body *property_spec* of the named property can be substituted in place of the instance, with actual arguments substituted for formal arguments, and result in a legal *property_expr* or *property_spec*. For example, if an instance of a named property is used as a *property_expr* operand for any property-building operator, then the named property must not have a **disable iff** clause.

16.13.9 Followed-by property

A property is a *followed-by* if it has one of the following forms, which use the followed-by operators shown in [Syntax 16-18](#).

```
property_expr ::= // from A.2.10
  ...
  | sequence_expr #-# property_expr
  | sequence_expr #=# property_expr
```

Syntax 16-18—Followed-by syntax (excerpt from [Annex A](#))

This clause is used to trigger monitoring of a property expression and is allowed at the property level.

The result of the followed-by is either true or false. The left-hand operand *sequence_expr* is called the *antecedent*, while the right-hand operand *property_expr* is called the *consequent*. For the followed-by property to succeed, the following must hold:

- From a given start point *sequence_expr* shall have at least one successful match.
- *property_expr* shall be successfully evaluated starting from the end point of some successful match of *sequence_expr*.

From a given start point, evaluation of the followed-by succeeds and returns true if, and only if, there exists a match of the antecedent *sequence_expr* beginning at the start point, and the evaluation of the consequent *property_expr* beginning at the end point of the match succeeds and returns true.

Two forms of followed-by are provided: Overlapped using operator #-# and nonoverlapped using operator #=#. For overlapped followed-by, there shall be a match for the antecedent *sequence_expr*, where the end point of this match is the start point of the evaluation of the consequent *property_expr*. For nonoverlapped followed-by, the start point of the evaluation of the consequent *property_expr* is the clock tick after the end point of the match.

The followed-by operators are the duals of the implication operators. Therefore, *sequence_expr* #-# *property_expr* is equivalent to the following:

```
not (sequence_expr |-> not property_expr)
```

and *sequence_expr* #=# *property_expr* is equivalent to the following:

```
not (sequence_expr |=> not property_expr)
```

Examples:

```
property p1;
  ##[0:5] done #-# always !rst;
endproperty
```

```

property p2;
    ##[0:5] done ==# always !rst;
endproperty

```

Property p1 says that `done` shall be asserted at some clock tick during the first 6 clock ticks, and starting from one of the clock ticks when `done` is asserted, `rst` shall always be low. Property p2 says that `done` shall be asserted at some clock tick during the first 6 clock ticks, and starting the clock tick after one of the clock ticks when `done` is asserted, `rst` shall always be low.

sequence_expr #-# **strong** (*sequence_expr1*) is semantically equivalent to **strong** (*sequence_expr* ##0 *sequence_expr1*), and *sequence_expr* ==# **strong** (*sequence_expr1*) is semantically equivalent to **strong** (*sequence_expr* ##1 *sequence_expr1*).

A followed-by operator is especially convenient for specifying a **cover property** directive over a sequence followed by a property.

16.13.10 Nexttime property

A property is a *nexttime* if it has one of the following forms, which use the nexttime operators:

nexttime *property_expr* (weak nexttime operator)

The weak nexttime property **nexttime** *property_expr* evaluates to true if, and only if, either the *property_expr* evaluates to true beginning at the next clock tick or there is no further clock tick.

nexttime [*constant_expression*] *property_expr* (indexed form of weak nexttime)

The indexed weak nexttime property **nexttime** [*constant_expression*] *property_expr* evaluates to true if, and only if, either there are not *constant_expression* clock ticks or *property_expr* evaluates to true beginning at the last of the next *constant_expression* clock ticks.

s_nexttime *property_expr* (strong nexttime)

The strong nexttime property **s_nexttime** *property_expr* evaluates to true if, and only if, there exists a next clock tick and *property_expr* evaluates to true beginning at that clock tick.

s_nexttime [*constant_expression*] *property_expr* (indexed form of strong nexttime)

The indexed strong nexttime property **s_nexttime** [*constant_expression*] *property_expr* evaluates to true if, and only if, there exist *constant_expression* clock ticks and *property_expr* evaluates to true beginning at the last of the next *constant_expression* clock ticks.

The comments in the following examples describe the conditions for the properties to be evaluated to true:

```

// if the clock ticks once more, then a shall be true at the next clock tick
property p1;
    nexttime a;
endproperty

// the clock shall tick once more and a shall be true at the next clock tick.
property p2;
    s_nexttime a;
endproperty

// as long as the clock ticks, a shall be true at each future clock tick
// starting from the next clock tick

```

```
property p3;
    nexttime always a;
endproperty

// the clock shall tick at least once more and as long as it ticks, a shall
// be true at every clock tick starting from the next one
property p4;
    s_nexttime always a;
endproperty

// if the clock ticks at least once more, it shall tick enough times for a to
// be true at some point in the future starting from the next clock tick
property p5;
    nexttime s_eventually a;
endproperty

// a shall be true sometime in the strict future
property p6;
    s_nexttime s_eventually a;
endproperty

// if there are at least two more clock ticks, a shall be true at the second
// future clock tick
property p7;
    nexttime[2] a;
endproperty

// there shall be at least two more clock ticks, and a shall be true at the
// second future clock tick
property p8;
    s_nexttime[2] a;
endproperty
```

16.13.11 Always property

A property is an *always* if it has one of the following forms, which use the always operators:

always *property_expr*

A property **always** *property_expr* evaluates to true if, and only if, *property_expr* holds at every current or future clock tick.

always [*cycle_delay_const_range_expression*] *property_expr* (ranged form of always)

A property **always** [*cycle_delay_const_range_expression*] *property_expr* evaluates to true if, and only if, *property_expr* holds at every current or future clock tick that is within the range of clock ticks specified by *cycle_delay_const_range_expression*. It is not required that all clock ticks within this range exist.

s_always [*constant_range*] *property_expr* (ranged strong form of s_always)

A property **s_always** [*constant_range*] *property_expr* evaluates to true if, and only if, all current or future clock ticks specified by *constant_range* exist and *property_expr* holds at each of these clock ticks.

The strong form of the always operator is allowed only with a bounded range.

There is also the implicit always that is associated with concurrent assertions (see [16.5](#)). A verification statement that is not placed inside an initial block specifies that an evaluation attempt of its top-level

property shall begin at each occurrence of its leading clocking event. In the following two examples, there is a one-to-one correspondence between the evaluation attempts of p specified by the implicit `always` from the verification statement `implicit_always` and the evaluation attempts of p specified by the explicit `always` operator in `explicit_always`:

Implicit form:

```
implicit_always: assert property (p);
```

Explicit form:

```
initial explicit_always: assert property (always p);
```

This is not shown as a practical example, but only for illustration of the meaning of `always`.

Examples:

```
initial a1: assume property ( @(posedge clk) reset[*5] ==# always !reset);

property p1;
  a ##1 b | => always c;
endproperty

property p2;
  always [2:5] a;
endproperty

property p3;
  s_always [2:5] a;
endproperty

property p4;
  always [2:$] a;
endproperty

property p5;
  s_always [2:$] a; // Illegal
endproperty
```

The assertion `a1` says that `reset` shall be true for the first 5 clock ticks and then remain 0 for the rest of the computation. The assumption is being evaluated once starting at the first clock tick. The property `p1` evaluates to true provided that if `a` is true at the first clock tick and `b` is true at the second clock tick, then `c` shall be true at every clock tick that follows the second. The properties `p2` and `p3` evaluate to true provided that `a` is true at each of the second through fifth clock ticks after the starting clock tick of the evaluation attempt. Property `p3` evaluates to true provided that these clock ticks exist, while property `p2` does not require that. The property `p4` evaluates to true if, and only if, `a` is true at every clock tick that is at least two clock ticks after the starting clock tick of the evaluation attempt. These clock ticks are not required to exist. The property `p5` is illegal since specifying an unbounded range is not permitted with the strong form of an `always` property.

16.13.12 Until property

A property is an *until* if it has one of the following forms, which use the until operators:

```
property_expr1 until property_expr2 (weak non-overlapping form)
property_expr1 s_until property_expr2 (strong non-overlapping form)
```

property_expr1 **until_with** property_expr2 (weak overlapping form)
property_expr1 **s_until_with** property_expr2 (strong overlapping form)

An until property of the non-overlapping form evaluates to true if *property_expr1* evaluates to true at every clock tick beginning with the starting clock tick of the evaluation attempt and continuing until at least one tick before a clock tick where *property_expr2* evaluates to true. An until property of one of the overlapping forms evaluates to true if *property_expr1* evaluates to true at every clock tick beginning with the starting clock tick of the evaluation attempt and continuing until and including a clock tick at which *property_expr2* evaluates to true. An until property of one of the strong forms requires a current or future clock tick exist at which *property_expr2* evaluates to true, while an until property of one of the weak forms does not make this requirement. An until property of one of the weak forms evaluates to true if *property_expr1* evaluates to true at each clock tick, even if *property_expr2* never holds.

Examples:

```
property p1;  
  a until b;  
endproperty  
  
property p2;  
  a s_until b;  
endproperty  
  
property p3;  
  a until_with b;  
endproperty  
  
property p4;  
  a s_until_with b;  
endproperty
```

Property p1 evaluates to true if, and only if, a is true at every clock tick beginning with the starting clock tick of the evaluation attempt and continuing until, but not necessarily including, a clock tick at which b is true. If there is no current or future clock tick at which b is true, then a shall be true at every current or future clock tick. If b is true at the starting clock tick of the evaluation attempt, then a need not be true at that clock tick. The property p2 evaluates to true provided that there exists a current or future clock tick at which b is true and that a is true at every clock tick beginning with the starting clock tick of the evaluation attempt and continuing until, but not necessarily including, the clock tick at which b is true. If b is true at the starting clock tick of the evaluation attempt, then a need not be true at that clock tick. The property p3 evaluates to true provided that a is true at every clock tick beginning with the starting clock tick of the evaluation attempt and continuing until and including a clock tick at which b is true. If there is no current or future clock tick at which b is true, then a shall be true at every current or future clock tick. The property p4 evaluates to true provided there exists a current or future clock tick at which b is true and that a is true at every clock tick beginning with the starting clock tick of the evaluation attempt and continuing until and including the clock tick at which b is true. The property p4 is equivalent to **strong**(a[*1:\$] ##0 b) (here a and b are Boolean expressions).

16.13.13 Eventually property

A property is an *eventually* if it has one of the following forms, which use the eventually operators:

```
s_eventually property_expr  
eventually [ constant_range ] property_expr (ranged weak form of eventually)  
s_eventually [ cycle_delay_const_range_expression ] property_expr  
  (ranged strong form of eventually)
```

The weak form of the eventually operator is allowed only with a bounded range.

s_eventually *property_expr* evaluates to true if, and only if, there exists a current or future clock tick at which *property_expr* evaluates to true. The ranged weak eventually property **eventually** [*constant_range*] *property_expr* evaluates to true if, and only if, either there exists a current or future clock tick within the range specified by *constant_range* at which *property_expr* evaluates to true or not all the current or future clock ticks within the range specified by *constant_range* exist. The ranged strong eventually property **s_eventually** [*cycle_delay_const_range_expression*] *property_expr* evaluates to true if, and only if, there exists a current or future clock tick within the range specified by *cycle_delay_const_range_expression* at which *property_expr* evaluates to true. The range for a strong eventually may be unbounded, but the range for a weak eventually shall be bounded.

In the following examples, a and b are Boolean expressions:

```

property p1;
  s_eventually a;
endproperty

property p2;
  s_eventually always a;
endproperty

property p3;
  always s_eventually a;
endproperty

property p4;
  eventually [2:5] a;
endproperty

property p5;
  s_eventually [2:5] a;
endproperty

property p6;
  eventually [2:$] a; // Illegal
endproperty

property p7;
  s_eventually [2:$] a;
endproperty

```

The property p1 evaluates to true if, and only if, there exists a current or future clock tick at which a is true. It is equivalent to **strong**(##[*0:\$] a). The property p2 evaluates to true if, and only if, there exist a current or future clock tick such that a is true both at that clock tick and also at every subsequent clock tick. On a computation with infinitely many clock ticks, the property p3 evaluates to true if, and only if, a is true at infinitely many of those clock ticks. On a computation with finitely many clock ticks, the property p3 evaluates to true provided that if there is at least one clock tick, then a holds at the last clock tick. The property p4 evaluates to true provided that if the second through fifth clock ticks from the starting clock tick of the evaluation attempt all exist, then a is true at one of these clock ticks. p4 is equivalent to **weak**(##[2:5] a). The property p5 evaluates to true if, and only if, there exist a clock tick at which a is true and that it is between the second and fifth clock ticks, inclusive, from the starting clock tick of the evaluation attempt. p5 is equivalent to **strong**(##[2:5] a). The property p7 evaluates to true if, and only if, there exist a clock tick at which a is true and that it is no earlier than the second clock tick after the starting clock tick of the evaluation attempt.

16.13.14 Abort properties

A property is an *abort* if it has one of the following forms:

accept_on (expression_or_dist) property_expr
reject_on (expression_or_dist) property_expr
sync_accept_on (expression_or_dist) property_expr
sync_reject_on (expression_or_dist) property_expr

where the *expression_or_dist* is called the *abort condition*. The properties **accept_on** and **reject_on** are called *asynchronous abort properties*, and the properties **sync_accept_on** and **sync_reject_on** are called *synchronous abort properties*.

For an evaluation of **accept_on** (*expression_or_dist*) *property_expr* and of **sync_accept_on** (*expression_or_dist*) *property_expr*, there is an evaluation of the underlying *property_expr*. If during the evaluation, the abort condition becomes true, then the overall evaluation of the property results in true. Otherwise, the overall evaluation of the property is equal to the evaluation of the *property_expr*.

For an evaluation of **reject_on** (*expression_or_dist*) *property_expr* and of **sync_reject_on** (*expression_or_dist*) *property_expr*, there is an evaluation of the underlying *property_expr*. If during the evaluation, the abort condition becomes true, then the overall evaluation of the property results in false. Otherwise, the overall evaluation of the property is equal to the evaluation of the *property_expr*.

The operators **accept_on** and **reject_on** are evaluated at the granularity of the simulation time step like **disable iff** but their abort condition is evaluated using sampled value as a regular Boolean expression in assertions. The operators **accept_on** and **reject_on** represent asynchronous resets.

The operators **sync_accept_on** and **sync_reject_on** are evaluated at the simulation time step when the clocking event happens, unlike **disable iff**, **accept_on** and **reject_on**. Their abort condition is evaluated using sampled value as for **accept_on** and **reject_on**. The operators **sync_accept_on** and **sync_reject_on** represent synchronous resets.

The semantics of **accept_on** is similar to **disable iff**, except for the following differences:

- **accept_on** operates at the property level rather than the concurrent assertion level.
- **accept_on** uses sampled values.
- While a disable condition of a **disable iff** in a *property_spec* may cause an evaluation of the *property_spec* to be disabled, an abort condition of **accept_on** in a *property_expr* may cause the evaluation of the *property_expr* to be true.

The semantics of **reject_on**(*expression_or_dist*) *property_expr* is the same as **not**(**accept_on**(*expression_or_dist*) **not**(*property_expr*)).

The semantics of **sync_accept_on** is similar to **accept_on**, except that it evaluates only at the time steps when the clocking event happens.

The semantics of **sync_reject_on**(*expression_or_dist*) *property_expr* is the same as **not**(**sync_accept_on**(*expression_or_dist*) **not**(*property_expr*)).

Any nesting of abort operators **accept_on**, **reject_on**, **sync_accept_on**, and **sync_reject_on** is allowed.

For example, whenever `go` is high, followed by two occurrences of `get` being high, then `stop` cannot be high until after `put` is asserted twice (not necessarily consecutive).

```
assert property (@(clk) go ##1 get[*2] |-> reject_on(stop) put[->2]);
```

In this example the `stop` is an asynchronous abort, its value is checked even between ticks of `clk`. The following is the synchronous version of the same example:

```
assert property (@(clk) go ##1 get[*2] |-> sync_reject_on(stop) put[->2]);
```

Here `stop` is checked only at the `clk` ticks. The latter assertion can also be written as follows:

```
assert property (@(clk) go ##1 get[*2] |-> !stop throughout put[->2]);
```

When the abort condition occurs at the same time step where the evaluation of the *property_expr* ends, the abort condition takes precedence. For example:

```
property p; (accept_on(a) p1) and (reject_on(b) p2); endproperty
```

If `a` becomes true during the evaluation of `p1`, the first term is ignored in deciding the truth of `p`. On the other hand, if `b` becomes true during the evaluation of `p2` then `p` evaluates to false.

```
property p; (accept_on(a) p1) or (reject_on(b) p2); endproperty
```

If `a` becomes true during the evaluation of `p1` then `p` evaluates to true. On the other hand, if `b` becomes true during the evaluation of `p2`, then the second term is ignored in deciding the truth of `p`.

```
property p; not (accept_on(a) p1); endproperty
```

not inverts the effect of the abort operator. Therefore, if `a` becomes true while evaluating `p1`, property `p` evaluates to false.

Nested **accept_on**, **reject_on**, **sync_accept_on** and **sync_reject_on** operators are evaluated in the lexical order (left to right). Therefore, if two nested operator conditions become true in the same time step during the evaluation of the argument property, then the outermost operator takes precedence. For example:

```
property p; accept_on(a) reject_on(b) p1; endproperty
```

If `a` becomes true in the same time step as `b` and during the evaluation of `p1`, then `p` succeeds in that time step. If `b` becomes true before `a` and during the evaluation of `p1`, then `p` fails.

The abort conditions may contain sampled value functions (see [16.9.3](#)). When sampled value functions other than `$sampled` are used in the abort condition, the clock argument shall be explicitly specified. Abort conditions shall not contain any reference to local variables and the sequence methods `triggered` and `matched`.

16.13.15 Weak and strong operators

The property operators **s_nexttime**, **s_always**, **s_eventually**, **s_until**, **s_until_with**, and sequence operator **strong** are strong: they require that some terminating condition happen in the future, and this includes the requirement that the property clock ticks enough time to enable the condition to happen.

The property operators **nexttime**, **always**, **until**, **eventually**, **until_with**, and sequence operator **weak** are weak: they do not impose any requirement on the terminating condition, and do not require the clock to tick.

The concept of weak and strong operators is closely related to an important notion of safety properties. Safety properties have the characteristic that all their failures happen at a finite time. For example, the property **always** *a* is a safety property since it is violated only if after finitely many clock ticks there is a clock tick at which *a* is false, even if there are infinitely many clock ticks in the computation. To the contrary, a failure of the property **s_eventually** *a* on a computation with infinitely many clock ticks cannot be identified at a finite time; if it is violated, the value of *a* must be false at each of the infinitely many clock ticks.

16.13.16 Case

The *case* property statement is a multiway decision that tests whether a Boolean expression matches one of a number of other Boolean expressions and branches accordingly (see [Syntax 16-19](#)).

```

property_statement ::= // from A.2.10
...
| case ( expression_or_dist ) property_case_item { property_case_item } endcase
...
property_case_item ::=
  expression_or_dist { , expression_or_dist } : property_statement
| default [ : ] property_statement

```

Syntax 16-19—Property statement case syntax (excerpt from [Annex A](#))

The *default* statement shall be optional. Use of multiple default statements in one property case statement shall be illegal.

A simple example of the use of the case property statement is the decoding of variable delay to produce a delay between the check of two signals as follows:

```

property p_delay(logic [1:0] delay);
  case (delay)
    2'd0   : a && b;
    2'd1   : a ##2 b;
    2'd2   : a ##4 b;
    2'd3   : a ##8 b;
    default: 0;           // cause a failure if delay has x or z values
  endcase
endproperty

```

During the linear search, if one of the case item expressions matches the case expression given in parentheses, then the property statement associated with that case item shall be evaluated, and the linear search shall terminate. If there is a default case item, it is ignored during this linear search. If all comparisons fail and the default item is given, then the default item property statement shall be executed. If the default property statement is not given and all of the comparisons fail, then none of the case item property statements shall be evaluated and the evaluation of the case property statement from that start point succeeds and returns true (vacuously).

The rules for comparing the case expression to the case item expressions are described in [12.5](#).

16.13.17 Recursive properties

SystemVerilog allows recursive properties. A named property is recursive if its declaration involves an instantiation of itself. Recursion provides a flexible framework for coding properties to serve as ongoing assumptions, obligations, or coverage monitors.

For example:

```
property prop_always(p);
  p and (1'b1 |=> prop_always(p));
endproperty
```

is a recursive property that says that the formal argument property *p* must hold at every cycle. This example is useful if the ongoing requirement that property *p* hold applies after a complicated triggering condition encoded in sequence *s*:

```
property p1(s,p);
  s |=> prop_always(p);
endproperty
```

As another example, the recursive property

```
property prop_weak_until(p,q);
  q or (p and (1'b1 |=> prop_weak_until(p,q)));
endproperty
```

says that formal argument property *p* must hold at every cycle up to, but not including, the first cycle at which formal argument property *q* holds. Formal argument property *q* is not required ever to hold, however. This example is useful if *p* must hold at every cycle after a complicated triggering condition encoded in sequence *s*, but the requirement on *p* is lifted by *q*:

```
property p2(s,p,q);
  s |=> prop_weak_until(p,q);
endproperty
```

More generally, several properties can be mutually recursive. For example:

```
property check_phase1;
  s1 |-> (phase1_prop and (1'b1 |=> check_phase2));
endproperty
property check_phase2;
  s2 |-> (phase2_prop and (1'b1 |=> check_phase1));
endproperty
```

There are four restrictions on recursive property declarations. They are as follows:

- RESTRICTION 1: The negation operator **not** and strong operators **s_nexttime**, **s_eventually**, **s_always**, **s_until**, and **s_until_with** cannot be applied to any property expression that instantiates a recursive property. In particular, the negation of a recursive property cannot be asserted or used in defining another property.

The following are examples of illegal property declarations that violate Restriction 1:

```
property illegal_recursion_1(p);
  not prop_always(not p);
endproperty
```

```
property illegal_recursion_2(p);  
  p and (1'b1 | => not illegal_recursion_2(p));  
endproperty
```

Furthermore, **not** cannot be applied to any property expression that instantiates a property that depends on a recursive property. The precise definition of dependency is given in [Annex F](#).

- RESTRICTION 2: The operator **disable iff** cannot be used in the declaration of a recursive property. This restriction is consistent with the restriction that **disable iff** cannot be nested.

The following is an example of an illegal property declaration that violates Restriction 2:

```
property illegal_recursion_3(p);  
  disable iff (b)  
  p and (1'b1 | => illegal_recursion_3(p));  
endproperty
```

The intent of `illegal_recursion_3` can be written legally as follows:

```
property legal_3(p);  
  disable iff (b) prop_always(p);  
endproperty
```

because `legal_3` is not a recursive property.

- RESTRICTION 3: If p is a recursive property, then, in the declaration of p , every instance of p must occur after a positive advance in time. In the case of mutually recursive properties, all recursive instances must occur after positive advances in time.

The following is an example of an illegal property declaration that violates Restriction 3:

```
property illegal_recursion_4(p);  
  p and (1'b1 | -> illegal_recursion_4(p));  
endproperty
```

If this form were legal, the recursion would be stuck in time, checking p over and over again at the same cycle.

- RESTRICTION 4: For every recursive instance of property q in the declaration of property p , each actual argument expression e of the instance satisfies at least one of the following conditions:
 - e is itself a formal argument of p .
 - No formal argument of p appears in e .
 - e is bound to a local variable formal argument of q .

For example:

```
property fibonacci1 (local input int a, b, n, int fib_sig);  
  (n > 0)  
  | ->  
  (  
    (fib_sig == a)  
    and  
    (1'b1 | => fibonacci1(b, a + b, n - 1, fib_sig))  
  );  
endproperty
```

is a legal declaration, but

```
property fibonacci2 (int a, b, n, fib_sig);
```

```

    (n > 0)
    |->
    (
        (fib_sig == a)
        and
        (1'b1 | => fibonacci2(b, a + b, n - 1, fib_sig))
    );
endproperty

```

is not legal because, in the recursive instance `fibonacci2(b, a+b, n-1, fib_sig)`, the actual argument expressions `a+b`, `n-1` are not themselves formal arguments of `fibonacci2`, are not bound to local variable formal arguments, and yet formal arguments of `fibonacci2` appear in these expressions.

The operators `accept_on`, `reject_on`, `sync_accept_on`, and `sync_reject_on` may be used inside a recursive property. For example, the following uses of `accept_on` and `reject_on` property are legal:

```

property p3(p, bit b, abort);
    (p and (1'b1 | => p4(p, b, abort)));
endproperty

property p4(p, bit b, abort);
    accept_on(b) reject_on(abort) p3(p, b, abort);
endproperty

```

Recursive properties can represent complicated requirements, such as those associated with varying numbers of data beats, out-of-order completions, retries, etc. Following is an example of using a recursive property to check complicated conditions of this kind.

For example, suppose that write data must be checked according to the following conditions:

- Acknowledgment of a write request is indicated by the signal `write_request` together with `write_request_ack`. When a write request is acknowledged, it gets a 4-bit tag, indicated by signal `write_request_ack_tag`. The tag is used to distinguish data beats for multiple write transactions in flight at the same time.
- It is understood that distinct write transactions in flight at the same time must be given distinct tags. For simplicity, this condition is not a part of what is checked in this example.
- Each write transaction can have between 1 data beat and 16 data beats, and each data beat is 8 bits. There is a model of the expected write data that is available at acknowledgment of a write request. The model is a 128-bit vector. The most significant group of 8 bits represents the expected data for the first beat, the next group of 8 bits represents the expected data for the second beat (if there is a second beat), and so forth.
- Data transfer for a write transaction occurs after acknowledgment of the write request and, barring retry, ends with the last data beat. The data beats for a single write transaction occur in order.
- A data beat is indicated by the `data_valid` signal together with the signal `data_valid_tag` to determine the relevant write transaction. The signal data are valid with `data_valid` and carry the data for that beat. The data for each beat must be correct according to the model of the expected write data.
- The last data beat is indicated by signal `last_data_valid` together with `data_valid` and `data_valid_tag`. For simplicity, this example does not represent the number of data beats and does not check that `last_data_valid` is signaled at the correct beat.
- At any time after acknowledgment of the write request, but not later than the cycle after the last data beat, a write transaction can be forced to retry. Retry is indicated by the signal `retry` together with signal `retry_tag` to identify the relevant write transaction. If a write transaction is forced to retry,

then its current data transfer is aborted, and the entire data transfer must be repeated. The transaction does not re-request, and its tag does not change.

- There is no limit on the number of times a write transaction can be forced to retry.
- A write transaction completes the cycle after the last data beat provided it is not forced to retry in that cycle.

The following is code to check these conditions:

```

property check_write;

  logic [0:127] expected_data; // local variable to sample model data
  logic [3:0] tag;           // local variable to sample tag

  disable iff (reset)
  (
    write_request && write_request_ack,
    expected_data = model_data,
    tag = write_request_ack_tag
  )
  |=>
  check_write_data_beat(expected_data, tag, 4'h0);

endproperty

property check_write_data_beat
(
  local input logic [0:127] expected_data,
  local input logic [3:0] tag, i
);
(
  (data_valid && (data_valid_tag == tag))
  ||
  (retry && (retry_tag == tag))
)[->1]
|->
(
  (
    (data_valid && (data_valid_tag == tag))
    |->
    (data == expected_data[i*8+:8])
  )
  and
  (
    if (retry && (retry_tag == tag))
    (
      1'b1 |=> check_write_data_beat(expected_data, tag, 4'h0)
    )
    else if (!last_data_valid)
    (
      1'b1 |=> check_write_data_beat(expected_data, tag, i+4'h1)
    )
  )
  else
  (
    ##1 (retry && (retry_tag == tag))
    |=>
    check_write_data_beat(expected_data, tag, 4'h0)
  )
)

```

```

    )
  );

  endproperty

```

16.13.18 Typed formal arguments in property declarations

The rules in [16.8.1](#) for typed formal arguments and their corresponding actual arguments apply to named properties, except as described next.

If a formal argument of a named property is typed, then the type shall be **property**, **sequence**, **event**, or one of the types allowed in [16.6.1](#). If the formal argument is of type **property**, then the corresponding actual argument shall be a *property_expr* and each reference to the formal argument shall be in a place where a *property_expr* may be written.

For example, a Boolean expression or a *sequence_expr* may be passed as actual argument to a formal argument of type **property** because each is a *property_expr*. A formal argument of type **property** may not be referenced as the antecedent of $| \rightarrow$ or $| \Rightarrow$ (see [16.13.6](#)), regardless of the corresponding actual argument, because a *property_expr* may not be written in that position.

16.13.19 Local variable formal arguments in property declarations

The rules in [16.8.2](#) for local variable formal arguments and their corresponding actual arguments apply to named properties, except as described next.

A local variable formal argument of a named property shall have direction **input**, either specified explicitly or inferred. It shall be illegal to declare a local variable formal argument of a named property with direction **inout** or **output**.

16.13.20 Property examples

The following examples illustrate the property forms:

```

property rule1;
  @(posedge clk) a |-> b ##1 c ##1 d;
endproperty
property rule2;
  @(clkev) disable iff (e) a |-> not(b ##1 c ##1 d);
endproperty

```

Property rule2 negates the sequence (b ##1 c ##1 d) in the consequent of the implication. clkev specifies the clock for the property.

```

property rule3;
  @(posedge clk) a[*2] |-> ((##[1:3] c) or (d | => e));
endproperty

```

Property rule3 says that if a holds and a also held last cycle, then either c must hold at some point one to three cycles after the current cycle or, if d holds in the current cycle, then e must hold one cycle later.

```

property rule4;
  @(posedge clk) a[*2] |-> ((##[1:3] c) and (d | => e));
endproperty

```

Property `rule4` says that if `a` holds and `a` also held last cycle, then `c` must hold at some point one to three cycles after the current cycle and, if `d` holds in the current cycle, then `e` must hold one cycle later.

```
property rule5;
  @(posedge clk)
  a ##1 (b || c) [->1] |->
    if (b)
      (##1 d |-> e)
    else // c
      f ;
endproperty
```

Property `rule5` has `a` followed by the next occurrence of either `b` or `c` as its antecedent. The consequent uses `if-else` to split cases on which of `b` or `c` is matched first.

```
property rule6(x, y);
  ##1 x |-> y;
endproperty
property rule5a;
  @(posedge clk)
  a ##1 (b || c) [->1] |->
    if (b)
      rule6(d, e)
    else // c
      f ;
endproperty
```

Property `rule5a` is equivalent to `rule5`, but it uses an instance of `rule6` as a property expression.

A property can optionally specify an event control for the clock. The clock derivation and resolution rules are described in [16.17](#).

A named property can be instantiated by referencing its name. A hierarchical name can be used, consistent with the SystemVerilog naming conventions. Like sequence declarations, variables used within a property that are not formal arguments to the property are resolved hierarchically from the scope in which the property is declared.

Properties that use more than one clock are described in [16.14](#).

16.13.21 Finite-length versus infinite-length behavior

The formal semantics in [Annex F](#) defines whether a given property holds on a given behavior. How the outcome of this evaluation relates to the design depends on the behavior that was analyzed. In dynamic verification, only behaviors that are finite in length are considered. In such a case, SystemVerilog defines the following four levels of satisfaction of a property:

- Holds strongly
 - No bad states have been seen.
 - All future obligations have been met.
 - The property will hold on any extension of the path.
- Holds (but does not hold strongly)
 - No bad states have been seen.
 - All future obligations have been met.
 - The property may or may not hold on a given extension of the path.

- Pending
 - No bad states have been seen.
 - Future obligations have not been met.
 - The property may or may not hold on a given extension of the path.
- Fails
 - A bad state has been seen.
 - Future obligations may or may not have been met.
 - The property will not hold on any extension of the path.

16.13.22 Nondegeneracy

It is possible to define sequences that can never be matched. For example:

```
(1'b1) intersect (1'b1 ##1 1'b1)
```

It is also possible to define sequences that admit only empty matches. For example:

```
1'b1[*0]
```

A sequence that admits no match or that admits only empty matches is called *degenerate*. A sequence that admits at least one nonempty match is called *nondegenerate*. A more precise definition of nondegeneracy is given in [Annex F](#).

The following restrictions apply:

- a) Any sequence that is used as a property shall be nondegenerate and shall not admit any empty match.
- b) Any sequence that is used as the antecedent of an overlapping implication ($| \rightarrow$) shall be nondegenerate.
- c) Any sequence that is used as the antecedent of a nonoverlapping implication ($| \Rightarrow$) shall admit at least one match. Such a sequence can admit only empty matches.

The reason for these restrictions is because the use of degenerate sequences in the forbidden ways results in counterintuitive property semantics, especially when the property is combined with a **disable iff** clause.

16.14 Multiclock support

Multiclock sequences and properties can be specified using the following syntax.

16.14.1 Multiclocked sequences

Multiclocked sequences are built by concatenating singly clocked subsequences using the single-delay concatenation operator **##1** or the zero-delay concatenation operator **##0**. The single delay indicated by **##1** is understood to be from the end point of the first sequence, which occurs at a tick of the first clock, to the nearest strictly subsequent tick of the second clock, where the second sequence begins. The zero delay indicated by **##0** is understood to be from the end point of the first sequence, which occurs at a tick of the first clock, to the nearest possibly overlapping tick of the second clock, where the second sequence begins.

Example 1:

```
@(posedge clk0) sig0 ##1 @(posedge clk1) sig1
```

A match of this sequence starts with a match of `sig0` at `posedge clk0`. Then `##1` moves the time to the nearest strictly subsequent `posedge clk1`, and the match of the sequence ends at that point with a match of `sig1`. If `clk0` and `clk1` are not identical, then the clocking event for the sequence changes after `##1`. If `clk0` and `clk1` are identical, then the clocking event does not change after `##1`, and the above sequence is equivalent to the singly clocked sequence

```
@(posedge clk0) sig0 ##1 sig1
```

Example 2:

```
@(posedge clk0) sig0 ##0 @(posedge clk1) sig1
```

A match of this sequence starts with a match of `sig0` at `posedge clk0`. Then `##0` moves the time to the nearest possibly overlapping `posedge clk1`, and the match of the sequence ends at that point with a match of `sig1`: if `posedge clk0` and `posedge clk1` happen simultaneously then the time does not move at `##0`, otherwise, it behaves as `##1`. If `clk0` and `clk1` are not identical, then the clocking event for the sequence changes after `##0`. If `clk0` and `clk1` are identical, then the clocking event does not change after `##0`, and the above sequence is equivalent to the following singly clocked sequence:

```
@(posedge clk0) sig0 ##0 sig1
```

which is equivalent to the following:

```
@(posedge clk0) sig0 && sig1
```

When concatenating differently clocked sequences, the maximal singly clocked subsequences are required to admit only nonempty matches. Thus, if `s1`, `s2` are sequence expressions with no clocking events, then the multiclocked sequence

```
@(posedge clk1) s1 ##1 @(posedge clk2) s2
```

is legal only if neither `s1` nor `s2` can match the empty word. The clocking event `@(posedge clk1)` applies throughout the match of `s1`, while the clocking event `@(posedge clk2)` applies throughout the match of `s2`. Because the match of `s1` is nonempty, there is an end point of this match at `posedge clk1`. The `##1` synchronizes between this end point and the first occurrence of `posedge clk2` strictly after it. That occurrence of `posedge clk2` is the start point of the match of `s2`.

A multiclocked sequence has well-defined starting and ending clocking events and well-defined clock changes because of the restriction that maximal singly clocked subsequences not match the empty word. If `clk1` and `clk2` are not identical, then the sequence

```
@(posedge clk0) sig0 ##1 @(posedge clk1) sig1[*0:1]
```

is illegal because of the possibility of an empty match of `sig1[*0:1]`, which would make ambiguous whether the ending clocking event is `@(posedge clk0)` or `@(posedge clk1)`.

Differently clocked or multiclocked sequence operands cannot be combined with any sequence operators other than `##1` and `##0`. For example, if `clk1` and `clk2` are not identical, then the following are illegal:

```
@(posedge clk1) s1 ##2 @(posedge clk2) s2
```

```
@(posedge clk1) s1 intersect @(posedge clk2) s2
```

16.14.2 Multiclocked properties

A clock may be explicitly specified with any property. The property is multiclocked if some of its subproperties have a clock different from the property clock, or some of its subproperties are multiclocked sequences.

As in the case of singly clocked properties, the result of evaluating a multiclocked property is either true or false. Multiclocked sequences are themselves multiclocked properties. For example:

```
@(posedge clk0) sig0 ##1 @(posedge clk1) sig1
```

is a multiclocked property. If a multiclocked sequence is evaluated as a property starting at some point, the evaluation returns true if, and only if, there is a match of the multiclocked sequence beginning at that point.

The following example shows how to form a multiclocked property using Boolean property operators:

```
(@(posedge clk0) sig0) and @(posedge clk1) sig1
```

This is a multiclocked property, but it is not a multiclocked sequence. This property evaluates to true at a point if, and only if, the two sequences

```
@(posedge clk0) sig0
```

and

```
@(posedge clk1) sig1
```

both have matches beginning at the point.

The meaning of multiclocked nonoverlapping implication is similar to that of singly clocked nonoverlapping implication. For example, if s_0 and s_1 are sequences with no clocking event, then in

```
@(posedge clk0) s0 |> @(posedge clk1) s1
```

$|>$ synchronizes between `posedge clk0` and `posedge clk1`. Starting at the point at which the implication is being evaluated, for each match of s_0 clocked by `clk0`, time is advanced from the end point of the match to the nearest strictly future occurrence of `posedge clk1`, and from that point there must exist a match of s_1 clocked by `clk1`.

The following example shows a combination of differently clocked properties using both implication and Boolean property operators:

```
@(posedge clk0) s0 |> ( @(posedge clk1) s1 ) and @(posedge clk2) s2
```

The multiclocked overlapping implication $|->$ has the following meaning: at the end of the antecedent the nearest tick of the consequent clock is awaited. If the consequent clock happens at the end of the antecedent, the consequent is started checking immediately. Otherwise, the meaning of the multiclocked overlapping implication is the same as the meaning of the multiclock nonoverlapping implication.

For example, if s_0 and s_1 are sequences with no clocking events, then

```
@(posedge clk0) s0 |-> @(posedge clk1) s1
```

means the following: at each match of s_0 the nearest **posedge** clk_1 is awaited. If it happens immediately then s_1 is checked without delay, otherwise its check starts at the next **posedge** clk_1 as in case with $|\Rightarrow$. In both cases the evaluation of s_1 is controlled by **posedge** clk_1 .

The semantics of multiclocked **if/if-else** operators is similar to the semantics of the overlapping implication. For example, if s_1 and s_2 are sequences with no clocking events, then

$$@(\text{posedge } clk_0) \text{ if } (b) @(\text{posedge } clk_1) s_1 \text{ else } @(\text{posedge } clk_2) s_2$$

has the following meaning: the condition b is checked at **posedge** clk_0 . If b is true then s_1 is checked at the nearest, possibly overlapping **posedge** clk_1 , else s_2 is checked at the nearest non-strictly subsequent **posedge** clk_2 .

16.14.3 Clock flow

Throughout this subclause, c and d denote clocking event expressions and $v, w, x, y,$ and z denote sequences with no clocking events.

Clock flow allows the scope of a clocking event to extend in a natural way through various parts of multiclocked sequences and properties and reduces the number of places at which the same clocking event must be specified.

Intuitively, clock flow provides that in a multiclocked sequence or property, the scope of a clocking event flows left to right across linear operators (e.g., repetition, concatenation, negation, implication, followed-by, and the **nexttime**, **always**, **eventually** operators) and distributes to the operands of branching operators (e.g., conjunction, disjunction, intersection, **if-else**, and the until operators) until it is replaced by a new clocking event.

For example:

$$@ (c) x |\Rightarrow @ (c) y \#\#1 @ (d) z$$

can be written more simply as

$$@ (c) x |\Rightarrow y \#\#1 @ (d) z$$

because clock c is understood to flow across $|\Rightarrow$.

Clock flow also makes the adjointness relationships between concatenation and implication clean for multiclocked properties:

$$@ (c) x \#\#1 y |\Rightarrow @ (d) z$$

is equivalent to

$$@ (c) x |\Rightarrow y |\Rightarrow @ (d) z$$

and

$$@ (c) x \#\#0 y |\Rightarrow @ (d) z$$

is equivalent to

$$@ (c) x |-\> y |\Rightarrow @ (d) z$$

The scope of a clocking event flows into parenthesized subexpressions and, if the subexpression is a sequence, also flows left to right across the parenthesized subexpression. However, the scope of a clocking event does not flow out of enclosing parentheses.

For example, in the following:

```
@(c) w ##1 (x ##1 @(d) y) |=> z
```

w, x, and z are clocked at c, and y is clocked at d. Clock c flows across ##1, across the parenthesized subsequence (x ##1 @(d) y), and across |=>. Clock c also flows into the parenthesized subsequence, but it does not flow through @(d). Clock d does not flow out of its enclosing parentheses.

As another example, in the following:

```
@(c) v |=> (w ##1 @(d) x) and (y ##1 z)
```

v, w, y, and z are clocked at c, and x is clocked at d. Clock c flows across |=>, distributes to both operands of the **and** (which is a property conjunction due to the multiple clocking), and flows into each of the parenthesized subexpressions. Within (w ##1 @(d) x), c flows across ##1 but does not flow through @(d). Clock d does not flow out of its enclosing parentheses. Within (y ##1 z), c flows across ##1.

Similarly, the scope of a clocking event flows into an instance of a named property. The scope of a clocking event flows into an instance of a named sequence provided neither method `triggered` nor method `matched` is applied to the instance of the sequence. The scope of a clocking event flows left to right across an instance of a sequence, regardless of whether method `triggered` or method `matched` is applied. A clocking event in the declaration of a sequence or property does not flow out of an instance of that sequence or property.

The scope of a clocking event does not flow into the disable condition of **disable iff**.

Juxtaposing two clocking events nullifies the first of them; therefore, the following two-clocking-event statement:

```
@(d) @(c) x
```

is equivalent to the following:

```
@(c) x
```

because the flow of clock d is immediately overridden by clock c.

16.14.4 Examples

The following are examples of multiclock specifications:

```
sequence s1;
  a ##1 b; // unclocked sequence
endsequence
sequence s2;
  c ##1 d; // unclocked sequence
endsequence
```

a) Multiclock sequence

```
sequence mult_s;
```

```
    @(posedge clk) a ##1 @(posedge clk1) s1 ##1 @(posedge clk2) s2;  
endsequence
```

- b) Property with a multiclock sequence

```
property mult_p1;  
    @(posedge clk) a ##1 @(posedge clk1) s1 ##1 @(posedge clk2) s2;  
endproperty
```

- c) Property with a named multiclock sequence

```
property mult_p2;  
    mult_s;  
endproperty
```

- d) Property with multiclock implication

```
property mult_p3;  
    @(posedge clk) a ##1 @(posedge clk1) s1 | => @(posedge clk2) s2;  
endproperty
```

- e) Property with implication, where antecedent and consequent are named multiclocked sequences

```
property mult_p6;  
    mult_s | => mult_s;  
endproperty
```

- f) Property using clock flow and overlapped implication

```
property mult_p7;  
    @(posedge clk) a ##1 b | -> c ##1 @(posedge clk1) d;  
endproperty
```

Here, a, b, and c are clocked at **posedge** clk.

- g) Property using clock flow and **if-else**

```
property mult_p8;  
    @(posedge clk) a ##1 b | ->  
    if (c)  
        (1 | => @(posedge clk1) d)  
    else  
        e ##1 @(posedge clk2) f ;  
endproperty
```

Here, a, b, c, e, and constant 1 are clocked at **posedge** clk.

16.14.5 Detecting and using end point of a sequence in multiclock context

Method `triggered` can be applied to detect the end point of a multiclocked sequence. Method `triggered` can also be applied to detect the end point of a sequence from within a multiclocked sequence. In both cases, the ending clock of the sequence instance to which `triggered` is applied shall be the same as the clock in the context where the application of method `triggered` appears.

To detect the end point of a sequence when the clock of the source sequence is different from the destination sequence, method `matched` on the source sequence is used. The end point of a sequence is reached whenever there is a match on its expression.

The syntax of the `matched` method is as follows:

```
sequence_instance.matched
```

`matched` is a method on a sequence that returns true or false. Unlike `triggered`, `matched` uses synchronization between the two clocks, by storing the result of the source sequence match until the arrival of the first destination clock tick after the match. The result of `matched` does not depend upon the starting point of the source sequence.

Like `triggered`, `matched` can be used on sequences that have formal arguments.

An example is shown as follows:

```
sequence e1(a,b,c);
  @(posedge clk) $rose(a) ##1 b ##1 c ;
endsequence
sequence e2;
  @(posedge sysclk) reset ##1 inst ##1 e1(ready,proc1,proc2).matched [->1]
  ##1 branch_back;
endsequence
```

In this example, source sequence `e1` is evaluated at clock `clk`, while the destination sequence `e2` is evaluated at clock `sysclk`. In `e2`, the end point of the instance `e1(ready,proc1,proc2)` is tested to occur sometime after the occurrence of `inst`. Notice that method `matched` only tests for the end point of `e1(ready,proc1,proc2)` and has no bearing on the starting point of `e1(ready,proc1,proc2)`.

Local variables can be passed into an instance of a named sequence to which `matched` is applied. The same restrictions apply as in the case of `triggered`. Values of local variables sampled in an instance of a named sequence to which `matched` is applied will flow out under the same conditions as for `triggered`. See [16.10](#).

As with `triggered`, a sequence instance to which `matched` is applied can have multiple matches in a single cycle of the destination sequence clock. The multiple matches are treated semantically the same way as matching both disjuncts of an `or`. In other words, the thread evaluating the destination sequence will fork to account for such distinct local variable valuations.

16.14.6 Sequence methods

Methods `triggered` and `matched` are available to identify the end point of a sequence. These methods are invoked using the following syntax:

```
sequence_instance.sequence_method
```

The results of these operations are true or false and do not depend upon the starting point of the match of their operand sequence. These methods can be invoked on sequences with formal arguments.

The value of method `triggered` evaluates to true if the given sequence has reached its end point at that particular point in time and false otherwise. The `triggered` status of the sequence is set in the Observed region and persists through the remainder of the time step. In addition to using this method in assertion statements, it may be used in `wait` statements (see [9.4.3](#)) or Boolean expressions outside a sequence context. It shall be considered an error to invoke this method outside a sequence context on sequences that

treat their formal arguments as local variables. A sequence treats its formal argument as a local variable if the formal argument is used as an lvalue in *operator_assignment* or *inc_or_dec_expression* in *sequence_match_item*. There shall be no circular dependencies between sequences induced by the use of `triggered`.

Unlike `triggered`, `matched` provides synchronization between two clocks by storing the result of the source sequence until the arrival of the first clock tick of the destination sequence after the match. The `matched` status of the sequence is set in the Observed region and persists until the Observed region following the arrival of the first clock tick of the destination sequence after the match. This method is used to detect the end point of a sequence used in a multiclocked sequence. `matched` can only be used in sequence expressions.

It shall be considered an error to use sequence methods in sampled value functions (see [16.9.3](#)) because the values of sequence methods are not available in the Preponed region.

An example of using the above methods on a sequence is shown as follows:

```
sequence e1;
  @(posedge sysclk) $rose(a) ##1 b ##1 c;
endsequence

sequence e2;
  @(posedge sysclk) reset ##1 inst ##1 e1.triggered ##1 branch_back;
endsequence

sequence e3;
  @(posedge clk) reset1 ##1 e1.matched ##1 branch_back1;
endsequence

program check;
  initial begin
    wait (e1.triggered || e2.triggered);
    if (e1.triggered)
      $display("e1 passed");
    if (e2.triggered)
      $display("e2 passed");
    L2: ...
  end
endprogram
```

In the example above, sequence `e2` tests for the end point of sequence `e1` using method `triggered` because both sequences use the same clock. The sequence `e3` tests for the end point of sequence `e1` using method `matched` because `e1` and `e3` use different clocks. The `initial` procedure in the program waits for the end point of either `e1` or `e2`. When either `e1` or `e2` evaluates to true, the `wait` statement unblocks the initial process. The process then displays the sequence that caused it to unblock, and then continues to execute at the statement labeled `L2`.

More details about sequence methods can be found in [9.4.4](#), [16.9.11](#), and [16.14.5](#).

16.14.7 Local variable initialization assignments

For singly-clocked sequences and properties, a local variable initialization assignment for an evaluation attempt of an instance of a named sequence or property is performed when the evaluation attempt begins. Such an evaluation attempt always begins in a time step in which there is a tick of the single governing clock.

For multiclock sequences and properties, a local variable initialization assignment for an evaluation attempt of an instance of a named sequence or property with a single semantic leading clock (see [16.17.1](#)) shall be performed at the earliest tick of the semantic leading clock that is at or after the beginning of the evaluation attempt. If there are two or more distinct semantic leading clocks for an instance of a named property, then a separate copy of the local variable shall be created for each semantic leading clock. For each copy of the local variable, the initialization assignment shall be performed at the earliest tick of the corresponding semantic leading clock that is at or after the beginning of the evaluation attempt, and that copy of the local variable shall be used in the evaluation of the subproperty associated with the corresponding semantic leading clock.

For example, let

```
property p;
  logic v = e;
  (@(posedge clk1) (a == v) [*1:$] |-> b)
  and
  (@(posedge clk2) c[*1:$] |-> d == v)
  ;
endproperty
a1: assert property (@(posedge clk) f |=> p);
```

where *f* is of type **logic**. The instance of *p* in assertion *a1* has two semantic leading clocks, **posedge** *clk1* and **posedge** *clk2*. Separate copies of the local variable *v* are created for the two subproperties governed by these clocks. Let *t0* be a time step in which **posedge** *clk* occurs and in which the sampled value of *f* is true. According to the structure of *a1*, an evaluation attempt of the instance of *p* starts strictly after *t0*. Let *t1* be the earliest time step after *t0* in which **posedge** *clk1* occurs, and let *t2* be the earliest time step after *t0* in which **posedge** *clk2* occurs. Then a declaration assignment *v* = *e* is performed in *t1*, and the value is assigned to the copy of *v* associated with **posedge** *clk1*. This value is used in the evaluation of the subproperty (a == v) [*1:\$] |-> b. Similarly, a declaration assignment *v* = *e* is performed in *t2*, and the value is assigned to the copy of *v* associated with **posedge** *clk2*. This value is used in the evaluation of the subproperty c[*1:\$] |-> d == v.

An equivalent declaration of *p* that does not use local variable declaration assignments is the following:

```
property p;
  logic v;
  (@(posedge clk1) (1, v = e) ##0 (a == v) [*1:$] |-> b)
  and
  (@(posedge clk2) (1, v = e) ##0 c[*1:$] |-> d == v)
  ;
endproperty
```

16.15 Concurrent assertions

A property on its own is never evaluated for checking an expression. It shall be used within an assertion statement (see [16.2](#)) for this to occur.

A concurrent assertion statement may be specified in any of the following:

- An always procedure or initial procedure as a statement, wherever these procedures may appear (see [9.2](#))
- A module
- An interface
- A program

- A generate block
- A checker

```

concurrent_assertion_item ::=                                     //from A.2.10
  [ block_identifier : ] concurrent_assertion_statement
  ...
procedural_assertion_statement ::=                             //from A.6.10
  concurrent_assertion_statement
  ...
concurrent_assertion_statement ::=
  assert_property_statement
  | assume_property_statement
  | cover_property_statement
  | cover_sequence_statement
  | restrict_property_statement
assert_property_statement ::=
  assert property ( property_spec ) action_block
assume_property_statement ::=
  assume property ( property_spec ) action_block
cover_property_statement ::=
  cover property ( property_spec ) statement_or_null
cover_sequence_statement ::=
  cover sequence ( [clocking_event] [ disable iff ( expression_or_dist ) ]
    sequence_expr ) statement_or_null
restrict_property_statement ::=
  restrict property ( property_spec ) ;

```

Syntax 16-20—Concurrent assert construct syntax (excerpt from [Annex A](#))

A concurrent assertion statement can be referenced by its optional name. A hierarchical name can be used consistent with the SystemVerilog naming conventions. When a name is not provided, a tool shall assign a name to the statement for the purpose of reporting. Assertion control system tasks are described in [20.11](#).

16.15.1 Assert statement

The **assert** statement is used to enforce a **property**. When the property for the **assert** statement is evaluated to be true, the pass statements of the action block are executed. When the property for the **assert** statement is evaluated to be false, the fail statements of the *action_block* are executed. When the property for the **assert** statement is evaluated to be disabled, no *action_block* statement is executed. The execution of pass and fail statements can be controlled by using assertion action control tasks. The assertion action control tasks are described in [20.12](#).

For example:

```

property abc(a, b, c);
  disable iff (a==2) @(posedge clk) not (b ##1 c);
endproperty
env_prop: assert property (abc(rst, in1, in2))
  $display("env_prop passed."); else $display("env_prop failed.");

```

When no action is needed, a null statement (i.e., ;) is specified. If no statement is specified for **else**, then `$error` is used as the statement when the assertion fails.

The *action_block* shall not include any concurrent **assert**, **assume**, or **cover** statement. The *action_block*, however, can contain immediate assertion statements.

The conventions regarding default severity (error) and the use of severity system tasks in concurrent assertion action blocks shall be the same as those specified for immediate assertions in [16.3](#).

The pass and fail statements of an assert statement are executed in the Reactive region. The regions of execution are explained in the scheduling semantics in [Clause 4](#).

16.15.2 Assume statement

The purpose of the **assume** statement is to allow properties to be considered as assumptions for formal analysis as well as for dynamic simulation tools. When a property is assumed, the tools constrain the environment so that the property holds.

For formal analysis, there is no obligation to verify that the assumed properties hold. An assumed property can be considered as a hypothesis to prove the asserted properties.

For simulation, the environment must be constrained so that the properties that are assumed shall hold. Like an asserted property, an assumed property must be checked and reported if it fails to hold. When the property for the **assume** statement is evaluated to be true, the pass statements of the *action_block* are executed. If it evaluates to false, the fail statements of the *action_block* are executed. For example:

```
property abc(a, b, c);
  disable iff (c) @(posedge clk) a |=> b;
endproperty
env_prop:
  assume property (abc(req, gnt, rst)) else $error("Assumption failed.");
```

If the property has a disabled evaluation, neither the pass nor fail statements of the *action_block* are executed. The execution of pass and fail statements can be controlled by using assertion action control tasks. The assertion action control tasks are described in [20.12](#).

Additionally, for random simulation, biasing on the inputs provides a way to make random choices. An expression can be associated with biasing as follows:

```
expression dist { dist_list } ; // from A.1.10
```

Distribution sets and the **dist** operator are explained in [18.5.4](#).

The biasing feature is useful when properties are considered as assumptions to drive random simulation. When a property with biasing is used within an **assert** or **cover** assertion statement, the **dist** operator is equivalent to **inside** operator, and the weight specification is ignored. For example:

```
a1:assume property ( @(posedge clk) req dist {0:=40, 1:=60} ) ;
property proto ;
  @(posedge clk) req |-> req[*1:$] ##0 ack;
endproperty
```

This is equivalent to the following:

```
a1_assertion:assert property ( @(posedge clk) req inside {0, 1} ) ;
```

```

property proto_assertion ;
  @(posedge clk) req |-> req[*1:$] ##0 ack;
endproperty

```

In the above example, signal `req` is specified with distribution in assumption `a1` and is converted to an equivalent assertion `a1_assertion`.

It should be noted that the properties that are assumed must hold in the same way with or without biasing. When using an assume statement for random simulation, the biasing simply provides a means to select values of free variables, according to the specified weights, when there is a choice of selection at a particular time.

Consider an example specifying a simple synchronous request and acknowledge protocol, where variable `req` can be raised at any time and must stay asserted until `ack` is asserted. In the next clock cycle, both `req` and `ack` must be deasserted.

Properties governing `req` are as follows:

```

property pr1;
  @(posedge clk) !reset_n |-> !req;           // when reset_n is asserted (0),
                                              // keep req 0
endproperty
property pr2;
  @(posedge clk) ack |=> !req;               // one cycle after ack, req
                                              // must be deasserted
endproperty
property pr3;
  @(posedge clk) req |-> req[*1:$] ##0 ack; // hold req asserted until
                                              // and including ack asserted
endproperty

```

Properties governing `ack` are as follows:

```

property pa1;
  @(posedge clk) !reset_n || !req |-> !ack;
endproperty
property pa2;
  @(posedge clk) ack |=> !ack;
endproperty

```

When verifying the behavior of a protocol controller that has to respond to requests on `req`, assertions `assert_ack1` and `assert_ack2` should be proven while assuming that statements `a1`, `assume_req1`, `assume_req2`, and `assume_req3` hold at all times.

```

a1:assume property (@(posedge clk) req dist {0:=40, 1:=60} );
assume_req1:assume property (pr1);
assume_req2:assume property (pr2);
assume_req3:assume property (pr3);

assert_ack1:assert property (pa1)
  else $display("\n ack asserted while req is still deasserted");
assert_ack2:assert property (pa2)
  else $display("\n ack is extended over more than one cycle");

```

16.15.3 Cover statement

There exist two categories of cover statements, **cover sequence** and **cover property**. The **cover sequence** statement specifies sequence coverage, while the **cover property** statement specifies property coverage. Both monitor behavioral aspects of the design for coverage. Tools shall collect coverage information and report the results at the end of simulation or on demand via an assertion API (refer to [Clause 39](#)). The difference between the two categories is that for sequence coverage, all matches per evaluation attempt are reported, whereas for property coverage the coverage count is incremented at most once per evaluation attempt. A cover statement may have an optional pass statement. The pass statement shall not include any concurrent **assert**, **assume**, or **cover** statement.

For property coverage, the statement appears as follows:

```
cover property ( property_spec ) statement_or_null
```

The results of this coverage statement for a property shall contain the following:

- Number of times attempted
- Number of times succeeded (maximum of one per attempt)
- Number of times succeeded because of vacuity

The pass statement specified in *statement_or_null* shall be executed once for each successful evaluation attempt of the underlying *property_spec*. The pass statement shall be executed in the Reactive region of the time step in which the corresponding evaluation attempt succeeds. The execution of *statement_or_null* can be controlled by using assertion action control tasks. The assertion action control tasks are described in [20.12](#).

The coverage counters above for success or vacuous success do not include disabled evaluations. The attempt counter includes the attempts which result in disabled evaluation. See [40.5.3](#) for details on obtaining assertion coverage results.

For sequence coverage, the statement appears as follows:

```
cover sequence (
  [clocking_event ] [ disable iff ( expression_or_dist ) ] sequence_expr )
  statement_or_null
```

Results of coverage for a sequence shall include the following:

- Number of times attempted
- Number of times matched (each attempt can generate multiple matches)

For a given attempt of the **cover sequence** statement, all matches of the *sequence_expr* that complete without the occurrence of the **disable iff** condition shall be counted, with multiplicity, toward the total number of times matched for the attempt. No other match shall be counted towards the total for the attempt. The pass statement specified in *statement_or_null* shall be executed, with multiplicity, for each match that is counted toward the total for the attempt. The pass statement shall be executed in the Reactive region of the time step in which the corresponding match completes. The execution of *statement_or_null* can be controlled by using assertion action control tasks. The assertion action control tasks are described in [20.12](#).

For a given attempt of the **cover sequence** statement, the total number of times matched for the attempt is equal to the number of times `increment_match_coverage()` is executed in the corresponding attempt of

```
assert property (
  [clocking_event] [ disable iff ( expression_or_dist ) ]
```

```
sequence_expr |-> ( 1'b1, increment_match_coverage() );
```

For each execution of `increment_match_coverage()`, the `pass` statement of the cover sequence statement is executed in the Reactive region of the same time step.

16.15.4 Restrict statement

In formal verification, for the tool to converge on a proof of a property or to initialize the design to a specific state, it is often necessary to constrain the state space. For this purpose, the assertion statement **restrict property** is introduced. It has the same semantics as **assume property**, however, in contrast to that statement, the **restrict property** statement is not verified in simulation and has no action block.

The statement has the following form:

```
restrict property ( property_spec );
```

There is no action block associated with the statement.

Example:

Suppose that when a control bit `ctr` has a value 0, an ALU performs an addition, and when it is 1, it performs a subtraction. It is required to formally verify that some behavior is correct when ALU does an addition (in another verification session it is possible to do the same for subtraction by changing the restriction). The behavior can thus be constrained using the statement.

```
restrict property (@(posedge clk) ctr == '0);
```

It does not mean that `ctr` cannot be 1 in any test case in the simulation, this is not an error.

16.15.5 Using concurrent assertion statements outside procedural code

A concurrent assertion statement can be used outside a procedural context. It can be used within a module, an interface, or a program. A concurrent assertion statement is an **assert**, an **assume**, a **cover**, or a **restrict** statement. Such a concurrent assertion statement uses the **always** semantics, meaning that it specifies that a new evaluation attempt of the underlying *property_spec* begins at every occurrence of its leading clock event.

The following two forms are equivalent:

```
assert property ( property_spec ) action_block  
always assert property ( property_spec ) action_block ;
```

Similarly, the following two forms are equivalent:

```
cover property ( property_spec ) statement_or_null  
always cover property ( property_spec ) statement_or_null
```

For example:

```
module top(input logic clk);  
  logic a,b,c;  
  property rule3;  
    @(posedge clk) a |-> b ##1 c;
```

```

    endproperty
    a1: assert property (rule3);
    ...
endmodule

```

rule3 is a property declared in module top. The assert statement a1 starts checking the property from the beginning to the end of simulation. The property is always checked. Similarly,

```

module top(input logic clk);
    logic a,b,c;
    sequence seq3;
        @(posedge clk) b ##1 c;
    endsequence
    c1: cover property (seq3);
    ...
endmodule

```

The cover statement c1 starts coverage of the sequence seq3 from beginning to the end of simulation. The sequence is always monitored for coverage.

16.15.6 Embedding concurrent assertions in procedural code

A concurrent assertion statement can also be embedded in a procedural block. For example:

```

property rule;
    a ##1 b ##1 c;
endproperty

always @(posedge clk) begin
    <statements>
    assert property (rule);
end

```

The term *procedural concurrent assertion* is used to refer to any concurrent assertion statement (see [16.2](#)) that appears in procedural code. Unlike an immediate assertion, a procedural concurrent assertion is not immediately evaluated when reached in procedural code. Instead, the assertion and the current values of all constant and automatic expressions appearing in its assertion arguments (see [16.15.6.1](#)) are placed in a *procedural assertion queue* associated with the currently executing process. Each of the entries in this queue is said to be a *pending procedural assertion instance*. Since any given statement in a procedure may be executed multiple times (as in a loop for example), a particular procedural concurrent assertion may result in many pending procedural assertion instances within a single time step. A concurrent assertion statement which appears outside procedural code is referred to as a *static concurrent assertion statement*.

In the Observed region of each simulation time step, each pending procedural assertion instance that is currently present in a procedural assertion queue shall *mature*, which means it is confirmed for execution. When a pending procedural assertion instance matures, if the current time step is one that corresponds to that assertion instance's leading clocking event, an evaluation attempt of the assertion begins immediately within the Observed region. If the assertion's leading clocking event has not occurred in this time step, the matured instance shall be placed on the *matured assertion queue*, which will cause the assertion to begin an evaluation attempt upon the next clocking event that corresponds to the leading clocking event of the assertion.

If a *procedural assertion flush point* (see [16.15.6.2](#)) is reached in a process, its procedural assertion queue is cleared. Any currently pending procedural assertion instances will not mature, unless again placed on the queue in the course of procedural execution.

If no clocking event is specified in a procedural concurrent assertion, the leading clocking event of the assertion shall be inferred from the procedural context, if possible. If no clock can be inferred from the procedural context, then the clocks shall be inferred from the default clocking (14.12), as if the assertion were instantiated immediately before the procedure.

A clock shall be inferred for the context of an always or initial procedure that satisfies the following requirements:

- a) There is no blocking timing control in the procedure.
- b) There is exactly one event control in the procedure.
- c) Within the event control of the procedure, there is exactly one event expression that satisfies both of the following conditions:
 - 1) The event expression is of the form *edge_identifier expression1 [iff expression2]* and is not a proper subexpression of an event expression of this form.
 - 2) No term in expression1 appears anywhere else in the body of the procedure.

If these requirements are satisfied, then the unique event expression from the third requirement shall be the clock inferred for the context of the procedure.

For example, in the following code fragment, the clocking event @(posedge mclk) is inferred as the clocking event of p1, while p2 is clocked by @(posedge scanclk) as written:

```

property r1;
  q != d;
endproperty
always @(posedge mclk) begin
  q <= d1;
  p1: assert property (r1);
  p2: assert property ( @(posedge scanclk) (r1) );
end

```

The resulting behavior of the above assertion p2 depends on the relative frequencies of mclk and scanclk. For example:

- If scanclk runs at twice the frequency of mclk, only every other posedge of scanclk will result in an evaluation of p2. It is only queued when reached during procedural execution, which happens on a rising edge of mclk.
- If mclk runs at twice the frequency of scanclk, then by every posedge of scanclk, two pending procedural instances of p2 will mature. Thus every posedge of scanclk will see p2 evaluated and results reported twice.

Also see 17.4 for the context clock inference in checkers.

Another, more complex example that is legal is as follows:

```

property r3;
  (q != d);
endproperty

always_ff @(posedge clock iff reset == 0 or posedge reset) begin
  r1 <= reset ? 0 : r1 + 1;
  q <= $past(d1);
  r3_p: assert property (r3);
end

```

In the example above, the inferred clock is `posedge clock iff reset == 0`. The inferred clock is not `posedge clock` because `posedge clock` is a proper subexpression of `posedge clock iff reset == 0`.

In contrast, no clock is inferred for the context of the `always_ff` in the following:

```
property r4;
    (q != d);
endproperty

always_ff @(clock iff reset == 0 or posedge reset) begin
    r1 <= reset ? 0 : r2 + 1;
    q <= $past(d1);           // no inferred clock
    r4_p: assert property (r4); // no inferred clock
end
```

The edge expression `posedge reset` cannot be inferred because `reset` is referenced within the procedure, and the expression `clock iff reset == 0` cannot be inferred because it does not have an edge identifier. In the absence of default clocking, the code above results in an error.

In the following example, no clock is inferred due to multiple event controls and delays in the `always` procedure.

```
property r5;
    q != d;
endproperty

always @(posedge mclk) begin
    #10 q <= d1; // delay prevents clock inference
    @(negedge mclk) // event control prevents clock inference
    #10 q1 <= !d1;
    r5_p: assert property (r5); // no inferred clock
end
```

16.15.6.1 Arguments to procedural concurrent assertions

As described in [16.15.5](#), a concurrent assertion outside procedural code uses the sampled values of each of its variables when being evaluated. Procedural concurrent assertions shall also use the sampled values of their arguments, with the following exception: a procedural concurrent assertion shall not sample any `const` expression or automatic variable, but shall instead save the value of the expression or variable at the time the assertion evaluation attempt is added to the procedural assertion queue. Using a `const` cast for expressions involving non-automatic variables provides a mechanism for avoiding sampling semantics for that variable. For example:

```
// Assume for this example that (posedge clk) will not occur at time 0
always @(posedge clk) begin
    int i = 10;
    for (i=0; i<10; i++) begin
        a1: assert property (foo[i] && bar[i]);
        a2: assert property (foo[const'(i)] && bar[i]);
        a3: assert property (foo[const'(i)] && bar[const'(i)]);
    end
end
```

In any given clock cycle, each of these assertions will result in 10 queued executions. Every execution of assertion `a1`, however, will be checking the value of `(foo[10] && bar[10])`, since the sampled value of

i will always be 10, its final value from the previous execution of the procedure. In the case of *a2*, its executions will be checking (*foo*[0] && *bar*[10]), (*foo*[1] && *bar*[10]), ... (*foo*[9] && *bar*[10]). Assertion *a3*, since it has **const** casts on both uses of *i*, will be checking (*foo*[0] && *bar*[0]), (*foo*[1] && *bar*[1]), ... (*foo*[9] && *bar*[9]). So the above code fragment is logically equivalent (aside from instance names) to the following:

```
default clocking @(posedge clk); endclocking
generate for (genvar i=0; i<10; i++) begin
  a1: assert property (foo[10] && bar[10]);
  a2: assert property (foo[i] && bar[10]);
  a3: assert property (foo[i] && bar[i]);
end
endgenerate
```

Since automatic variables also have their immediate values preserved, in the following example, all three properties *a4*, *a5*, and *a6* are logically equivalent:

```
always @(posedge clk) begin
  // variable declared in for statement is automatic (see 12.7.1)
  for (int i=0; i<10; i++) begin
    a4: assert property (foo[i] && bar[i]);
    a5: assert property (foo[const'(i)] && bar[i]);
    a6: assert property (foo[const'(i)] && bar[const'(i)]);
  end
end
```

When a procedural concurrent assertion contains temporal expressions and has matured, the execution flow of the procedure no longer directly affects the matured instance in future time steps. In other words, the procedural execution only affects the activation of the assertion instance, not the completion of temporal expressions in the future. However, any constant values that were passed into the assertion instance due to constant or automatic variables will remain constant for the duration of that instance's evaluation. The following example illustrates this behavior:

```
wire w;
always @(posedge clk) begin : procedural_block_1
  if (my_activation_condition == 1) begin
    for (int i=0; i<2; i++) begin
      a7: assume property (foo[i] | => bar[i] ##1 (w==1'b1));
    end
  end
end
```

During the time step when *my_activation_condition* is 1, two pending instances of *a7* will be placed on the procedural assertion queue, one for each value of *i*. Assume that they successfully mature, and *foo*[0] is true in the current time step. This means that on the next *posedge* of *clk*, regardless of the execution of *procedural_block_1* or the value of *my_activation_condition*, that matured instance of *a7* will be checking that *bar*[0] is true. The constant value of the automatic *i* from when the assertion was queued is still in effect, for this and any future clock cycles of this assertion evaluation. Then, one cycle later, the assertion will also be checking that the sampled value of *w* is 1'b1.

The same rules that apply to procedural concurrent assertion arguments also apply to variables appearing in their action blocks. Thus, constant or automatic values may be used in action blocks as well as the assertion statements themselves, where they behave as inputs to the action block that shall not be modified. The following example illustrates this behavior:

```
// Assume for this example that (posedge clk) will not occur at time 0
```

```

always @(posedge clk) begin
  int i = 10;
  for (i=0; i<10; i++) begin
    a8: assert property (foo[const'(i)] && bar[i]) else
      $error("a8 failed for const i=%d and i=%d",
             const'(i), $sampled(i));
  end
end

```

Upon a failure, any instance of the above assertion will show the constant value of *i* (may be from 0 to 9) that was used in that instance for “const i=”, while the string printed will always end in “i=10”, since 10 will be the sampled value captured from the Preponed region.

When embedding procedural concurrent assertions in code using conditionals, it is important to remember that the current values of the conditionals in the procedure are used, rather than the sampled values. This contrasts with the assertion’s arguments, where sampled values are the default (except for automatic variables and **const** casts as described previously.) The following example illustrates this situation:

```

// Assume a, b, c, and en are not automatic
always @(posedge clk) begin
  en = ...;
  if (en) begin
    a9: assert property p1(a,b,c);
  end
  if ($sampled(en)) begin
    a10: assert property p1(a,b,c);
  end
end

```

Assertion *a9* is queued on any time step when *en* becomes true, while *a10* is queued on any time step when the sampled value of *en* in the Preponed region was true. Thus, assuming nothing else in the code modifies *en*, checks of *a10* will happen a time step later than checks on *a9*, even though both use the sampled values of *a*, *b*, and *c* on their respective time steps.

NOTE—This is an area of backwards-incompatibility between this standard and 17.13 of IEEE Std 1800-2005. In the 2005 definition, *en* would have been detected as the *inferred enabling condition* (a definition that no longer exists in this standard) of *a9* and always sampled, so *a9* and *a10* would have identical behavior.

16.15.6.2 Procedural assertion flush points

A process is defined to have reached a procedural assertion flush point if any of the following occur:

- The process, having been suspended earlier due to reaching an event control or **wait** statement, resumes execution.
- The process was declared by an **always_comb** or **always_latch**, and its execution is resumed due to a transition on one of its dependent signals.
- The outermost scope of the process is disabled by a **disable** statement (see [16.15.6.4](#)).

The following example shows how procedural concurrent assertions inherently avoid multiple evaluations due to transitional combinational values in a single simulation time step:

```

assign not_a = !a;
default clocking @(posedge clk); endclocking
always_comb begin : b1
  // Probably better to not use consts in this example
  // ...but using them to illustrate effects of flushing method
  a1: assert property (const'(not_a) != const'(a));
end

```

When *a* changes in a time step during which a positive clock edge occurs, a simulator could evaluate assertion *a1* twice—once for the change in *a* and once for the change in *not_a* after the evaluation of the continuous assignment. The first execution of *a1*, which would have ended up reporting a failure, will be scheduled on the process's procedural assertion queue. When *not_a* changes, the procedural assertion queue is flushed due to the activation of *b1*, and a new pending instance of the procedural concurrent assertion will now be queued with the correct values, so no failure of *a1* will be reported.

The following example illustrates the behavior of procedural concurrent assertions in the presence of time delays:

```
default clocking @(posedge clk); endclocking
always @(a or b) begin : b1
    a2: assert property (a == b) r.success(0) else r.error(0, a, b);
    #1;
    a3: assert property (a == b) r.success(1) else r.error(1, a, b);
end
```

In this case, due to the time delay in the middle of the procedure, an Observed region will always be reached after the queuing of *a2* and before a flush point. Thus *a2* will always mature. For *a3*, during time steps where either *a* or *b* changes after it has been queued, the assertion will always be flushed from the queue and never mature. In general, procedural concurrent assertions must be used carefully when mixed with time delays.

The following example illustrates a typical use of a procedural concurrent assertion statement with a **cover** rather than an **assert**:

```
assign a = ...;
assign b = ...;
default clocking @(posedge clk); endclocking
always_comb begin : b1
    ...
    c1: cover property (const'(b) != const'(a));
end
```

In this example, the goal is to make sure some test is covering the case where *a* and *b* have different values at that point in the procedural code. Due to the arbitrary order of the assignments in the simulator, it might be the case that in a cycle where there is a positive clock edge and both variables are being assigned the same value, *b1* executes while *a* has been assigned but *b* still holds its previous value. Thus *c1* will be queued, but this is actually a glitch, and probably not a useful piece of coverage information. But, when *b1* is executed the next time (after *b* has also been assigned its new value), that coverage point will be flushed, and when the coverage point matures, *c2* will correctly not get reported as having been covered during that time step.

16.15.6.3 Procedural concurrent assertions and glitches

One common concern with assertion execution is glitches, where the same assertion executes multiple times in a time step, and reports undesired failures on temporary values that have not yet received their final values for the step. In general, procedural concurrent assertions are immune to glitches due to order of procedural execution due to the flushing mechanism, but are still subject to glitches caused by execution loops between regions.

For example, if code in the Reactive region modifies signals and causes another pass to the Active region to occur, this may create some glitching behavior, as the new passage in the Active region may re-queue procedural concurrent assertions, and a second evaluation attempt may be added to the matured assertion queue. The following code illustrates this situation.

```

always_comb begin : procedural_block_1
  if (en)
    foo = bar;
end

always_comb begin : procedural_block_2
  p1: assert property ( @(posedge clk) (const'(foo) == const'(bar)) );
end

```

Suppose `bar` is assigned a new value elsewhere in the code at the posedge of the clock, and `en` is 1 so the assignment in `procedural_block_1` takes place. Block `procedural_block_2` may be executed twice in the Active region: once upon the initial change to `bar`, and once after the assignment that updates `foo`. Upon the first execution of `procedural_block_2`, a pending instance of `p1` will be queued, and would result in failure of the assertion if it matured. But this instance will be flushed upon the second execution of the procedural block before maturing, and thus there will be no glitch.

However, now suppose that in the same example, `en` is 0, and the assignment of the `bar` value to `foo` happens through VPI code in the Reactive region. In this case, the Observed region has already occurred, so `p1` has matured and executed, and reported the assertion failure due to `foo` and `bar` having different values. After the Reactive region, there will be another Active region in which `procedural_block_2` will be executed, and this time a newly queued instance of `p1` will pass. But this is too late to prevent the report of the failure earlier in the time step.

16.15.6.4 Disabling procedural concurrent assertions

The `disable` statement shall interact with procedural concurrent assertions as follows:

- A specific procedural concurrent assertion may be disabled. Any pending procedural instances of that assertion are cleared from the queue. Any pending procedural instances of other assertions remain in the queue.
- When a `disable` is applied to the outermost scope of a procedure that has a pending procedural assertion queue, in addition to normal disable activities (see [9.6.2](#)), the pending procedural assertion queue is flushed and all pending assertion instances on the queue are cleared.

Once a procedural concurrent assertion evaluation attempt has matured, it shall not be impacted by any `disable`.

Disabling a task or a non-outermost scope of a procedure does not cause flushing of any pending procedural assertion instances.

The following example illustrates how user code can explicitly flush a pending procedural assertion instance. In this case, instances of `a1` only mature in time steps where `bad_val_ok` does not settle at a value of 1.

```

default clocking @(posedge clk); endclocking
always @(bad_val or bad_val_ok) begin : b1
  a1: assert property (bad_val) else $fatal("Sorry");
  if (bad_val_ok) begin
    disable a1;
  end
end
end

```

The following example illustrates how user code can explicitly flush all pending procedural assertion instances on the procedural assertion queue of process `b2`:

```

default clocking @(posedge clk); endclocking

```

```
always @(a or b or c) begin : b2
  if (c == 8'hff) begin
    a2: assert property (a && b);
  end else begin
    a3: assert property (a || b);
  end
end

always @(clear_b2) begin : b3
  disable b2;
end
```

16.15.7 Inferred value functions

The following elaboration time system functions are available to query the inferred clocking event expression and disable expression:

- `$inferred_clock` returns the expression of the inferred clocking event.
- `$inferred_disable` returns the inferred disable expression.

The inferred clocking event expression is the current resolved event expression that can be used in a clocking event definition. It is obtained by applying clock flow rules to the point where `$inferred_clock` is called. If there is no current resolved event expression when `$inferred_clock` is encountered then an error shall be issued.

The inferred disable expression is the disable condition from the default disable declaration whose scope includes the call to `$inferred_disable` (see [16.16](#)). If the call to `$inferred_disable` is not within the scope of any default disable declaration, then the call to `$inferred_disable` returns `1'b0` (false).

A call to an inferred expression function may only be used as the entire default value expression for a formal argument to a property or sequence declaration. A call to an inferred expression function shall not appear within the body expression of a property or sequence declaration. If a call to an inferred expression function is used as the entire default value expression for a formal argument to a property or sequence declaration, then it is replaced by the inferred expression as determined at the point where the property or sequence is instantiated. Therefore, if the property or sequence instance is the top-level property expression in an assertion statement, the event expression that is used to replace the default argument `$inferred_clock` is that as determined at the location of the assertion statement. If the property or sequence instance is not the top-level property expression in the assertion statement then the event expression determined by clock flow rules up to the instance location in the property expression is used as the default value of the argument.

Consider the following example:

```
module m(logic a, b, c, d, rst1, clk1, clk2);

  logic rst;

  default clocking @(negedge clk1); endclocking
  default disable iff rst1;

  property p_triggers(start_event, end_event, form, clk = $inferred_clock,
                    rst = $inferred_disable);
    @clk disable iff (rst)
    (start_event ##0 end_event[->1]) |=> form;
  endproperty

  property p_multiclock(clkw, clkx = $inferred_clock, clkz, w, x, y, z);
```

```

    @clkw w ##1 @clkx x |=> @clky y ##1 z;
endproperty

a1: assert property (p_triggers(a, b, c));
a2: assert property (p_triggers(a, b, c, posedge clk1, 1'b0) );

always @(posedge clk2 or posedge rst) begin
    if (rst) ... ;
    else begin
        a3: assert property (p_triggers(a, b, c));
        ...
    end
end

a4: assert property(p_multiclock(negedge clk2, , posedge clk1,
    a, b, c, d) );

endmodule

```

The above code is logically equivalent to the following:

```

module m(logic a, b, c, d, rst1, clk1, clk2);

    logic rst;

    a1: assert property (@(negedge clk1) disable iff (rst1)
        a ##0 b[->1] |=> c);

    a2: assert property (@(posedge clk1) disable iff (1'b0)
        a ##0 b[->1] |=> c);

    always @(posedge clk2 or posedge rst) begin
        if (rst) ... ;
        else begin
            ...
        end
    end

    a3: assert property
    (
        @(posedge clk2) disable iff (rst1)
        (a ##0 b[->1]) |=> c
    );

    a4: assert property (@(negedge clk2) a ##1 @(negedge clk1) b |=>
        @(posedge clk1) c ##1 d);

endmodule

```

In assertion a1 the clock event is inferred from the default clocking, therefore `$inferred_clock` is `negedge clk1` for a1. In assertion a2 the event expression `posedge clk1` is passed to the formal argument `clk` in the instance of property `p_triggers`. Therefore, the `$inferred_clock` is not used for `clk` in that instance. In assertion a3 the clocking event is inferred from the event control of the always procedure, therefore `$inferred_clock` is `posedge clk2` for a3.

In assertion a4, as the property `p_multiclock` is instantiated in the `assert property` statement, `clkw` is replaced by the actual argument (`negedge clk2`), `clkx` by the default argument value `$inferred_clock`, which is the default clocking clock (`negedge clk1`) at the location of the property

instance in the assertion. The third clock, `clky`, is replaced by the actual argument (`posedge clk1`) because it is explicitly specified.

The disable condition `rst1` is inferred for assertions `a1` and `a3` from the default disable statement. Assertion `a2` uses explicit reset value `1'b0` in which case the `disable iff` statement could be omitted altogether in the equivalent assertion.

16.15.8 Nonvacuous evaluations

An evaluation attempt of a property is either vacuous or nonvacuous. In the following, nonvacuous evaluation is described for the following kinds of properties: sequence, negation, disjunction, conjunction, if-else, implication, and instantiation.

- a) An evaluation attempt of a property that is a sequence is always nonvacuous.
- b) An evaluation attempt of a property of the form `strong (sequence_expr)` is always nonvacuous.
- c) An evaluation attempt of a property of the form `weak (sequence_expr)` is always nonvacuous.
- d) An evaluation attempt of a property of the form `not property_expr` is nonvacuous if, and only if, the underlying evaluation attempt of `property_expr` is nonvacuous.
- e) An evaluation attempt of a property of the form `property_expr1 or property_expr2` is nonvacuous if, and only if, either the underlying evaluation attempt of `property_expr1` is nonvacuous or the underlying evaluation attempt of `property_expr2` is nonvacuous.
- f) An evaluation attempt of a property of the form `property_expr1 and property_expr2` is nonvacuous if, and only if, either the underlying evaluation attempt of `property_expr1` is nonvacuous or the underlying evaluation attempt of `property_expr2` is nonvacuous.
- g) An evaluation attempt of a property of the form `if (expression_or_dist) property_expr1` is nonvacuous if, and only if, `expression_or_dist` evaluates to true and the underlying evaluation attempt of `property_expr1` is nonvacuous.

An evaluation attempt of a property of the form `if (expression_or_dist) property_expr1 else property_expr2` is nonvacuous if, and only if, either `expression_or_dist` evaluates to true and the underlying evaluation attempt of `property_expr1` is nonvacuous, or `expression_or_dist` evaluates to false and the underlying evaluation attempt of `property_expr2` is nonvacuous.

- h) An evaluation attempt of a property of the form `sequence_expression |-> property_expr` is nonvacuous if, and only if, there is a successful match of the antecedent `sequence_expression` and the evaluation attempt of `property_expr` that starts at the end point of the match is nonvacuous.

An evaluation attempt of a property of the form `sequence_expression |=> property_expr` is nonvacuous if, and only if, there is a successful match of the antecedent `sequence_expression` and the evaluation attempt of `property_expr` that starts at the clock event following the end point of the match is nonvacuous.

- i) An evaluation attempt of an instance of a property is nonvacuous if, and only if, the underlying evaluation attempt of the `property_expr` that results from substituting actual arguments for formal arguments is nonvacuous.
- j) An evaluation attempt of a property of the form `sequence_expression #-# property_expr` is nonvacuous if, and only if, there is a successful match of the antecedent `sequence_expression` and the evaluation attempt of `property_expr` that starts at the end point of the match is nonvacuous.
- k) An evaluation attempt of a property of the form `sequence_expression #=# property_expr` is nonvacuous if, and only if, there is a successful match of the antecedent `sequence_expression` and the evaluation attempt of `property_expr` that starts at the clock event following the end point of the match is nonvacuous.

- l) An evaluation attempt of a property of the form **nexttime** *property_expr* is nonvacuous if, and only if, there is at least one more clock event, and in the evaluation attempt that start in the next clock event, *property_expr* is nonvacuous.
- m) An evaluation attempt of a property of the form **nexttime** [*constant_expression*] *property_expr* is nonvacuous if, and only if, there is at least *constant_expression* more clock events, and *property_expr* is nonvacuous, in the evaluation attempt beginning at the last of the next *constant_expression* clock events.
- n) An evaluation attempt of a property of the form **s_nexttime** *property_expr* is nonvacuous if, and only if, there is at least one more clock event, and in the evaluation attempt starting at the next clock event *property_expr* is nonvacuous.
- o) An evaluation attempt of a property of the form **s_nexttime** [*constant_expression*] *property_expr* is nonvacuous if, and only if, there is at least *constant_expression* more clock events, and *property_expr* is nonvacuous, in the evaluation attempt beginning at the last of the next *constant_expression* clock events.
- p) An evaluation attempt of a property of the form **always** *property_expr* is nonvacuous if, and only if, there is a clock event where the evaluation attempt of *property_expr* is nonvacuous, and *property_expr* does not fail in prior clock events.
- q) An evaluation attempt of a property of the form **always** [*cycle_delay_const_range_expression*] *property_expr* is nonvacuous if, and only if, there is a clock event within the range specified by *cycle_delay_const_range_expression*, in which the evaluation attempt of *property_expr* is nonvacuous, and the *property_expr* does not fail in prior clock events that within the range specified by *cycle_delay_const_range_expression*.
- r) An evaluation attempt of a property of the form **s_always** [*constant_range*] *property_expr* is nonvacuous if, and only if, there is a clock event within the range specified by *constant_range*, in which the evaluation attempt of *property_expr* is nonvacuous, and *property_expr* does not fail in prior clock events within the range specified by *constant_range*.
- s) An evaluation attempt of a property of the form **s_eventually** *property_expr* is nonvacuous if, and only if, there is a clock event in which the evaluation attempt of *property_expr* is nonvacuous, and the *property_expr* does not hold in prior clock events.
- t) An evaluation attempt of a property of the form **s_eventually** [*cycle_delay_const_range_expression*] *property_expr* is nonvacuous if, and only if, there is a clock event within the range specified by *cycle_delay_const_range_expression*, in which the evaluation attempt of *property_expr* is nonvacuous, and *property_expr* does not hold in prior clock events within the range specified by *cycle_delay_const_range_expression*.
- u) An evaluation attempt of a property of the form **eventually** [*constant_range*] *property_expr* is nonvacuous if, and only if, there is a clock event within the range specified by *constant_range*, in which the evaluation attempt of *property_expr* is nonvacuous, and *property_expr* does not hold in prior clock events within the range specified by *constant_range*.
- v) An evaluation attempt of a property of the form *property_expr1* **until** *property_expr2* is nonvacuous if, and only if, there is a clock event in which either the evaluation attempt of *property_expr1* or the evaluation attempt of *property_expr2* is nonvacuous, *property_expr2* does not hold in prior clock events, and *property_expr1* holds in all prior clock events.
- w) An evaluation attempt of a property of the form *property_expr1* **s_until** *property_expr2* is nonvacuous if, and only if, there is a clock event in which either the evaluation attempt of *property_expr1* or the evaluation attempt of *property_expr2* is nonvacuous, *property_expr2* does not hold in prior clock events, and *property_expr1* holds in all prior clock events.
- x) An evaluation attempt of a property of the form *property_expr1* **until_with** *property_expr2* is nonvacuous if, and only if, there is a clock event in which the evaluation attempt of *property_expr1* is nonvacuous, *property_expr2* does not hold in prior clock events, and *property_expr1* holds in all prior clock events.

- y) An evaluation attempt of a property of the form *property_expr1 s_until_with property_expr2* is nonvacuous if, and only if, there is a clock event in which the evaluation attempt of *property_expr1* is nonvacuous, *property_expr2* does not hold in prior clock events, and *property_expr1* holds in all prior clock events.
- z) An evaluation attempt of a property of the form *property_expr1 implies property_expr2* is nonvacuous if, and only if, the evaluation attempt of *property_expr1* is nonvacuous.
- aa) An evaluation attempt of a property of the form *property_expr1 iff property_expr2* is nonvacuous if, and only if, either the evaluation attempt of *property_expr1* is nonvacuous or the evaluation attempt of *property_expr2* is nonvacuous.
- ab) An evaluation attempt of a property of the form **accept_on** (*expression_or_dist*) *property_expr* is nonvacuous if, and only if, the underlying evaluation attempt of *property_expr* is nonvacuous and *expression_or_dist* does not hold in any time step of that evaluation attempt.
- ac) An evaluation attempt of a property of the form **reject_on** (*expression_or_dist*) *property_expr* is nonvacuous if, and only if, the underlying evaluation attempt of *property_expr* is nonvacuous and *expression_or_dist* does not hold in any timestep of that evaluation attempt.
- ad) An evaluation attempt of a property of the form

```

case (expression_or_dist)
  expression_or_dist1 : property_stmt1
  ...
  expression_or_distn : property_stmtn
  [ default : property_stmtd ]
endcase

```

is nonvacuous if and only if:

- For some index *i* such that $1 \leq i \leq n$, (*expression_or_dist* === *expression_or_dist*_{*i*}) and
 - For each index *j* such that $1 \leq j < i$, (*expression_or_dist* !== *expression_or_dist*_{*j*}) and
 - The underlying evaluation attempt of *property_stmt*_{*i*} is nonvacuous
- or
- The default is present and
 - For each index *i* such that $1 \leq i \leq n$, (*expression_or_dist* !== *expression_or_dist*_{*i*}) and
 - The underlying evaluation attempt of *property_stmt*_{*d*} is nonvacuous.

- ae) An evaluation attempt of a property of the form **disable iff** (*expression_or_dist*) *property_expr* is nonvacuous if, and only if, the underlying evaluation attempt of *property_expr* is nonvacuous and *expression_or_dist* does not hold in any time step of that evaluation attempt.

An evaluation attempt of a property succeeds nonvacuously if, and only if, the property evaluates to true and the evaluation attempt is nonvacuous.

16.16 Disable iff resolution

```

module_or_generate_item_declaration ::= //from A.1.4
...
| default clocking clocking_identifier ;
| default disable iff expression_or_dist ;

```

Syntax 16-21—Default clocking and default disable syntax (excerpt from [Annex A](#))

A default **disable iff** may be declared within a generate block or within a module, interface, or program declaration. It provides a default disable condition to all concurrent assertions in the scope and subscopes of the default **disable iff** declaration. Furthermore, the default extends to any nested module, interface, or program declarations, and to nested generate blocks. However, if a nested module, interface, or program declaration, or a generate block itself has a default **disable iff** declaration, then that default **disable iff** applies within the nested declaration or generate block and overrides any default **disable iff** from outside. Any signals referenced in the **disable iff** declaration that are resolved using scopes will be resolved from the scope of the declaration.

The effect of a default **disable iff** declaration is independent of the position of the declaration within that scope. More than one default **disable iff** declaration within the same module, interface, program declaration, or generate block shall be an error. The scope does not extend into any instances of modules, interfaces or programs.

In the following example, module `m1` declares `rst1` to be the default disable condition, and there is no default **disable iff** declaration in the nested module `m2`. The default disable condition `rst1` applies throughout the declaration of `m1` and the nested declaration of `m2`. Therefore, the inferred disable condition of both assertions `a1` and `a2` is `rst1`.

```

module m1;
  bit clk, rst1;
  default disable iff rst1;
  a1: assert property (@(posedge clk) p1);    // property p1 is
                                             // defined elsewhere
  ...
  module m2;
    bit rst2;
    ...
    a2: assert property (@(posedge clk) p2); // property p2 is
                                             // defined elsewhere

  endmodule
  ...
endmodule

```

If there is a default **disable iff** declaration in the nested module `m2`, then within `m2` this default disable condition overrides the default disable condition declared in `m1`. Therefore, in the following example the inferred disable condition of `a1` is `rst1`, but the inferred disable condition of `a2` is `rst2`.

```

module m1;
  bit clk, rst1;
  default disable iff rst1;
  a1: assert property (@(posedge clk) p1);    // property p1 is
                                             // defined elsewhere
  ...
  module m2;
    bit rst2;
    default disable iff rst2;
    ...
    a2: assert property (@(posedge clk) p2); // property p2 is
                                             // defined elsewhere

  endmodule
  ...
endmodule

```

The following rules apply for resolution of the disable condition:

- a) If an assertion has a **disable iff** clause, then the disable condition specified in this clause shall be used and any default **disable iff** declaration ignored for this assertion.
- b) If an assertion does not contain a **disable iff** clause, but the assertion is within the scope of a default **disable iff** declaration, then the disable condition for the assertion is inferred from the default **disable iff** declaration.
- c) Otherwise, no inference is performed (this is equivalent to the inference of a 1'b0 disable condition).

Below are two example modules illustrating the application of these rules.

```
module examples_with_default (input logic a, b, clk, rst, rst1);
    default disable iff rst;
    property p1;
        disable iff (rst1) a |=> b;
    endproperty

    // Disable condition is rst1 - explicitly specified within a1
    a1 : assert property @(posedge clk) disable iff (rst1) a |=> b;

    // Disable condition is rst1 - explicitly specified within p1
    a2 : assert property @(posedge clk) p1;

    // Disable condition is rst - no explicit specification, inferred from
    // default disable iff declaration
    a3 : assert property @(posedge clk) a |=> b;

    // Disable condition is 1'b0. This is the only way to
    // cancel the effect of default disable.
    a4 : assert property @(posedge clk) disable iff (1'b0) a |=> b;
endmodule

module examples_without_default (input logic a, b, clk, rst);
    property p2;
        disable iff (rst) a |=> b;
    endproperty

    // Disable condition is rst - explicitly specified within a5
    a5 : assert property @(posedge clk) disable iff (rst) a |=> b;

    // Disable condition is rst - explicitly specified within p2
    a6 : assert property (@ (posedge clk) p2);

    // No disable condition
    a7 : assert property (@ (posedge clk) a |=> b);

endmodule
```

16.17 Clock resolution

There are a number of ways to specify a clock for a property. They are as follows:

- Sequence instance with a clock, for example:

```
sequence s2; @(posedge clk) a ##2 b; endsequence
property p2; not s2; endproperty
assert property (p2);
```

- Property, for example:

```
property p3; @(posedge clk) not (a ##2 b); endproperty
assert property (p3);
```

- Contextually inferred clock from a procedural block, for example:

```
always @(posedge clk) assert property (not (a ##2 b));
```

- A **clocking** block, for example:

```
clocking master_clk @(posedge clk);
    property p3; not (a ##2 b); endproperty
endclocking
assert property (master_clk.p3);
```

- Default clock, for example:

```
default clocking master_clk ; // master clock as defined above
property p4; (a ##2 b); endproperty
assert property (p4);
```

In general, a clocking event applies throughout its scope except where superseded by an inner clocking event, as with clock flow in multiclocked sequences and properties. The following rules apply:

- a) In a module, interface, program, or checker with a default clocking event, a concurrent assertion statement that has no otherwise specified leading clocking event is treated as though the default clocking event had been written explicitly as the leading clocking event. The default clocking event does not apply to a sequence or property declaration except in the case that the declaration appears in a **clocking** block whose clocking event is the default.
- b) The following rules apply within a **clocking** block:
 - 1) No explicit clocking event is allowed in any property or sequence declaration within the **clocking** block. All sequence and property declarations within the **clocking** block are treated as though the clocking event of the **clocking** block had been written explicitly as the leading clocking event.
 - 2) Multiclocked sequences and properties are not allowed within the **clocking** block.
 - 3) If a named sequence or property that is declared outside the **clocking** block is instantiated within the **clocking** block, the instance shall be singly clocked and its clocking event shall be identical to that of the **clocking** block.
- c) A contextually inferred clocking event from a procedural block supersedes a default clocking event. The contextually inferred clocking event is treated as though it had been written as the leading clocking event of any concurrent assertion statement to which the inferred clock applies. The maximal property of such a concurrent assertion statement shall be singly clocked.
- d) An explicitly specified leading clocking event in a concurrent assertion statement supersedes a default clocking event.
- e) A multiclocked sequence or property can inherit the default clocking event as its leading clocking event. If a multiclocked property is the maximal property of a concurrent assertion statement, then the property shall have a unique semantic leading clock (see [16.17.1](#)).
- f) If a concurrent assertion statement has no explicit leading clocking event, there is no default clocking event, and no contextually inferred clocking event applies to the assertion statement, then the maximal property of the assertion statement shall be an instance of a sequence or property for which a unique leading clocking event is determined.

The following are two example modules illustrating the application of these rules with some legal and some illegal declarations, as indicated by the comments:

```

module examples_with_default (input logic a, b, c, clk);

  property q1;
    $rose(a) |-> ##[1:5] b;
  endproperty

  property q2;
    @(posedge clk) q1;
  endproperty

  default clocking posedge_clk @(posedge clk);
    property q3;
      $fell(c) |=> q1;
      // legal: q1 has no clocking event
    endproperty

    property q4;
      $fell(c) |=> q2;
      // legal: q2 has clocking event identical to that of
      // the clocking block
    endproperty

    sequence s1;
      @(posedge clk) b[*3];
      // illegal: explicit clocking event in clocking block
    endsequence
  endclocking

  property q5;
    @(negedge clk) b[*3] |=> !b;
  endproperty

  always @(negedge clk)
  begin
    a1: assert property ($fell(c) |=> q1);
      // legal: contextually inferred leading clocking event,
      // @(negedge clk)
    a2: assert property (posedge_clk.q4);
      // legal: will be queued (pending) on negedge clk, then
      // (if matured) checked at next posedge clk (see 16.15.6)
    a3: assert property ($fell(c) |=> q2);
      // illegal: multiclocked property with contextually
      // inferred leading clocking event
    a4: assert property (q5);
      // legal: contextually inferred leading clocking event,
      // @(negedge clk)
  end

  property q6;
    q1 and q5;
  endproperty

  a5: assert property (q6);
    // illegal: default leading clocking event, @(posedge clk),
    // but semantic leading clock is not unique

```

```
a6: assert property ($fell(c) | => q6);
    // legal: default leading clocking event, @(posedge clk),
    // is the unique semantic leading clock

sequence s2;
    $rose(a) ##[1:5] b;
endsequence

c1: cover property (s2);
    // legal: default leading clocking event, @(posedge clk)
c2: cover property @(negedge clk) s2;
    // legal: explicit leading clocking event, @(negedge clk)

endmodule

module examples_without_default (input logic a, b, c, clk);

    property q1;
        $rose(a) |-> ##[1:5] b;
    endproperty

    property q5;
        @(negedge clk) b[*3] | => !b;
    endproperty

    property q6;
        q1 and q5;
    endproperty

a5: assert property (q6);
    // illegal: no leading clocking event
a6: assert property ($fell(c) | => q6);
    // illegal: no leading clocking event

sequence s2;
    $rose(a) ##[1:5] b;
endsequence

c1: cover property (s2);
    // illegal: no leading clocking event
c2: cover property @(negedge clk) s2;
    // legal: explicit leading clocking event, @(negedge clk)

sequence s3;
    @(negedge clk) s2;
endsequence

c3: cover property (s3);
    // legal: leading clocking event, @(negedge clk),
    // determined from declaration of s3
c4: cover property (s3 ##1 b);
    // illegal: no default, inferred, or explicit leading
    // clocking event and maximal property is not an instance

endmodule
```

16.17.1 Semantic leading clocks for multiclocked sequences and properties

Throughout this subclause, s , s_1 , and s_2 denote sequences without clocking events; p , p_1 , and p_2 denote properties without clocking events; m , m_1 , and m_2 denote multiclocked sequences, q , q_1 , and q_2 denote multiclocked properties; and c , c_1 , and c_2 denote nonidentical clocking event expressions.

This subclause defines a notion of the set of semantic leading clocks for a multiclocked sequence or property.

Some sequences and properties have no explicit leading clock event. Their initial clocking event is inherited from an outer clocking event according to the flow of clocking event scope. In this case, the semantic leading clock is said to be *inherited*. For example, in the property

$$@ (c) s \mid \Rightarrow p \text{ and } @ (c_1) p_1$$

the semantic leading clock of the subproperty p is inherited because the initial clock of p is the clock that flows across $\mid \Rightarrow$.

A multiclocked sequence has a unique semantic leading clock, defined inductively as follows:

- The semantic leading clock of s is *inherited*.
- The semantic leading clock of $@ (c) s$ is c .
- If *inherited* is the semantic leading clock of m , then the semantic leading clock of $@ (c) m$ is c . Otherwise, the semantic leading clock of $@ (c) m$ is equal to the semantic leading clock of m .
- The semantic leading clock of (m) is equal to the semantic leading clock of m .
- The semantic leading clock of $m_1 \#\#1 m_2$ is equal to the semantic leading clock of m_1 .
- The semantic leading clock of $m_1 \#\#0 m_2$ is equal to the semantic leading clock of m_1 .

The set of semantic leading clocks of a multiclocked property is defined inductively as follows:

- The set of semantic leading clocks of **strong** (m) is $\{c\}$, where c is the unique semantic leading clock of m .
- The set of semantic leading clocks of **weak** (m) is $\{c\}$, where c is the unique semantic leading clock of m .
- The set of semantic leading clocks of p is $\{inherited\}$.
- If *inherited* is an element of the set of semantic leading clocks of q , then the set of semantic leading clocks of $@ (c) q$ is obtained from the set of semantic leading clocks of q by replacing *inherited* by c . Otherwise, the set of semantic leading clocks of $@ (c) q$ is equal to the set of semantic leading clocks of q .
- The set of semantic leading clocks of (q) is equal to the set of semantic leading clocks of q .
- The set of semantic leading clocks of **not** q is equal to the set of semantic leading clocks of q .
- The set of semantic leading clocks of q_1 **and** q_2 is the union of the set of semantic leading clocks of q_1 with the set of semantic leading clocks of q_2 .
- The set of semantic leading clocks of q_1 **or** q_2 is the union of the set of semantic leading clocks of q_1 with the set of semantic leading clocks of q_2 .
- The set of semantic leading clocks of $m \mid \rightarrow p$ is equal to the set of semantic leading clocks of m .
- The set of semantic leading clocks of $m \mid \Rightarrow p$ is equal to the set of semantic leading clocks of m .
- The set of semantic leading clocks of **if** (b) q is $\{inherited\}$.
- The set of semantic leading clocks of **if** (b) q_1 **else** q_2 is $\{inherited\}$.
- The set of semantic leading clocks of **case** (b) $b_1: q_1 \dots b_n: q_n$ [**default**: q_d] **endcase** is $\{inherited\}$.

- The set of semantic leading clocks of `nexttime q` is *{inherited}*.
- The set of semantic leading clocks of `always q` is *{inherited}*.
- The set of semantic leading clocks of `s_eventually q` is *{inherited}*.
- The set of semantic leading clocks of `q1 until q2` is *{inherited}*.
- The set of semantic leading clocks of `q1 until_with q2` is *{inherited}*.
- The set of semantic leading clocks of `accept_on(b) q` is the set of semantic leading clocks of `q`.
- The set of semantic leading clocks of `reject_on(b) q` is the set of semantic leading clocks of `q`.
- The set of semantic leading clocks of `sync_accept_on(b) q` is *{inherited}*.
- The set of semantic leading clocks of `sync_reject_on(b) q` is *{inherited}*.
- The set of semantic leading clocks of a property instance is equal to the set of semantic leading clocks of the multiclocked property obtained from the body of its declaration by substituting in actual arguments.

For example, the multiclocked sequence

```
@(c1) s1 ##1 @(c2) s2
```

has `c1` as its unique semantic leading clock, while the multiclocked property

```
not (p1 and @(c2) p2)
```

has *{inherited, c₂}* as its set of semantic leading clocks.

In the presence of an incoming outer clock, the inherited semantic leading clock is always understood to refer to the incoming outer clock. Therefore, the clocking of a property `q` in the presence of incoming outer clock `c` is equivalent to the clocking of the property `@(c) q`.

A multiclocked property has a unique semantic leading clock in case when all its leading clocks are identical. Consider the following example:

```
wire clk1, clk2;
logic a, b;
...
assign clk2 = clk1;
a1: assert property (@(clk1) a and @(clk2) b); // Illegal
a2: assert property (@(clk1) a and @(clk1) b); // OK
always @(posedge clk1) begin
  a3: assert property(a and @(posedge clk2)); //Illegal
  a4: assert property(a and @(posedge clk1)); // OK
end
```

The assertions `a2` and `a4` are legal, while the assertions `a1` and `a3` are not. Though both clocks of `a1` have the same value, they are not identical. Therefore, `a1` does not have a unique semantic leading clock. The assertions `a3` and `a4` have `@(posedge clk1)` as their inferred clock. This clock is not identical to `@(posedge clk2)` therefore `a3` does not have a unique semantic leading clock.

16.18 Expect statement

The **expect** statement is a procedural blocking statement that allows waiting on a property evaluation. The syntax of the **expect** statement accepts a named property or a property declaration and is given in [Syntax 16-22](#).

```
expect_property_statement ::= //from A.2.10  
expect ( property_spec ) action_block
```

Syntax 16-22—Expect statement syntax (excerpt from [Annex A](#))

The **expect** statement accepts the same syntax used to assert a property. An **expect** statement causes the executing process to block until the given property succeeds or fails. The statement following the **expect** is scheduled to execute after processing the Observed region in which the property completes its evaluation. When the property succeeds or fails, the process unblocks, and the property stops being evaluated (i.e., no property evaluation is started until that **expect** statement is executed again).

When executed, the **expect** statement starts a single thread of evaluation for the given property on the subsequent clocking event, that is, the first evaluation shall take place on the next clocking event. If the property fails at its clocking event, the optional **else** clause of the action block is executed. If the property succeeds, the optional pass statement of the action block is executed. The execution of pass and fail statements can be controlled by using assertion action control tasks. The assertion action control tasks are described in [20.12](#).

```
program tst;  
  initial begin  
    # 200ms;  
    expect( @(posedge clk) a ##1 b ##1 c ) else $error( "expect failed" );  
    ABC: ...  
  end  
endprogram
```

In the above example, the **expect** statement specifies a property that consists of the sequence a ##1 b ##1 c. The **expect** statement (second statement in the **initial** procedure of program `tst`) blocks until the sequence a ##1 b ##1 c is matched or is determined not to match. The property evaluation starts on the occurrence of the **posedge** `clk` event following the 200 ms delay. If the sequence is matched, the process is unblocked and continues to execute on the statement labeled `ABC`. If the sequence fails to match, then the **else** clause is executed, which in this case generates a run-time error. For the **expect** above to succeed, the sequence a ##1 b ##1 c must match starting on the occurrence of the **posedge** `clk` event immediately after time 200ms. The sequence will not match if a, b, or c is evaluated to be false at the first, second, or third clocking event occurrence, respectively.

The **expect** statement can be incorporated in any procedural code, including tasks or class methods. Because it is a blocking statement, the property can refer to automatic variables as well as static variables. For example, the task below waits between 1 and 10 clock ticks for the variable `data` to equal a particular value, which is specified by the automatic argument value. The second argument, `success`, is used to return the result of the **expect** statement: 1 for success and 0 for failure.

```
integer data;  
...  
task automatic wait_for( integer value, output bit success );  
expect( @(posedge clk) ##[1:10] data == value ) success = 1;  
  else success = 0;  
endtask  
  
initial begin  
  bit ok;  
  wait_for( 23, ok ); // wait for the value 23  
  ...  
end
```

16.19 Clocking blocks and concurrent assertions

If a variable used in a concurrent assertion is a **clocking** block variable, it will be sampled only in the **clocking** block.

Examples:

```
module A;
  logic a, clk;

  clocking cb_with_input @(posedge clk);
    input a;
    property p1;
      a;
    endproperty
  endclocking

  clocking cb_without_input @(posedge clk);
    property p1;
      a;
    endproperty
  endclocking

  property p1;
    @(posedge clk) a;
  endproperty

  property p2;
    @(posedge clk) cb_with_input.a;
  endproperty

  a1: assert property (p1);
  a2: assert property (cb_with_input.p1);
  a3: assert property (p2);
  a4: assert property (cb_without_input.p1);

endmodule
```

Figure 16-17 explains the behavior of all the assertions. In the above example, a1, a2, a3, and a4 are equivalent.

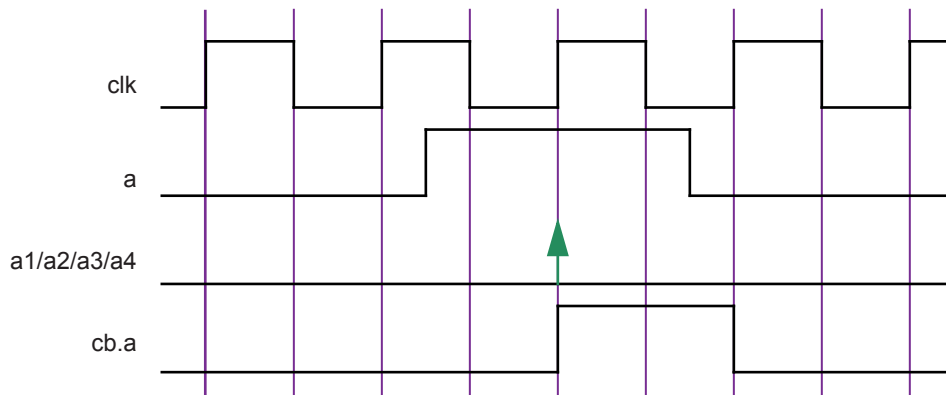

Figure 16-17—Clocking blocks and concurrent assertion

17. Checkers

17.1 Overview

Assertions provide building blocks to validate the behavior of the design. In many cases there is a need to group several assertions together into bigger blocks having a well-defined functionality. These verification blocks may also need to contain modeling code to compute values of auxiliary variables used in assertions or covergroup instances to be integrated with cover statements. The checker construct in SystemVerilog was specifically created to represent such verification blocks encapsulating assertions along with the modeling code. The intended use of checkers is to serve as verification library units, or as building blocks for creating abstract auxiliary models used in formal verification.

The modeling mechanism in checkers is limited to nonblocking assignments only. Each variable declared in a checker may be either deterministic or random. Checker modeling is explained in [17.7](#). Random variables are useful to build abstract nondeterministic models for formal verification. Reasoning about nondeterministic models is sometimes much easier than reasoning about deterministic RTL models.

Deterministic variables allow a conventional (deterministic) modeling for assertions. Using random variables instead of regular variables in checkers has the advantage that the same checker may be used for both deterministic and nondeterministic cases.

17.2 Checker declaration

```

checker_declaration ::= //from A.1.2
    checker checker_identifier [ ( [ checker_port_list ] ) ] ;
    { checker_or_generate_item }
    endchecker [ : checker_identifier ]

checker_port_list ::= //from A.1.8
    checker_port_item { , checker_port_item }

checker_port_item ::=
    { attribute_instance } property_formal_type port_identifier {variable_dimension}
    [ = property_actual_arg ]

checker_or_generate_item ::=
    checker_or_generate_item_declaration
    | initial_construct
    | checker_always_construct
    | final_construct
    | assertion_item
    | checker_generate_item

checker_or_generate_item_declaration ::=
    [ rand ] data_declaration
    | function_declaration
    | assertion_item_declaration
    | covergroup_declaration
    | overload_declaration
    | genvar_declaration
    | clocking_declaration
    | default clocking clocking_identifier ;
    | default disable iff expression_or_dist ;
    | ;

```

```
checker_generate_item6 ::=  
    loop_generate_construct  
    | conditional_generate_construct  
    | generate_region  
    | elaboration_system_task  
checker_always_construct ::= always statement  
checker_identifier ::=  
    identifier
```

//from [A.9.3](#)

6) It shall be illegal for a checker_generate_item to include any item that would be illegal in a checker_declaration outside a checker_generate_item.

Syntax 17-1—Checker declaration syntax (excerpt from [Annex A](#))

A checker may be declared in one of the following:

- A module
- An interface
- A program
- A checker
- A package
- A generate block
- A compilation unit scope

A checker is declared using the keyword **checker** followed by a name and optional formal argument list, and ending with the keyword **endchecker**.

The following elements from the scope enclosing the checker declaration shall not be referenced in a checker:

- Automatic variables and members or elements of dynamic variables. This includes dynamically sized variables and data in automatic tasks, functions, or blocks.
- Elements of **fork...join**, **fork...join_any**, or **fork...join_none** blocks.

Action blocks of assertions within a checker will be referred to as *checker action blocks*, and the rest of the checker will be referred to as a *checker body*.

A checker body may contain the following elements:

- Declarations of **let** constructs, sequences, properties and functions
- Deferred assertions (see [16.4](#))
- Concurrent assertions (see [16.15](#))
- Checker declarations
- Other checker instantiations
- Covergroup declarations and instances
- Checker variable declarations and assignments (see [17.7](#))
- **default clocking** and **default disable iff** declarations
- **initial**, **always** and **final** procedures (see [9.2](#))
- Generate blocks, containing any of the above elements

Modules, interfaces, programs, and packages shall not be declared inside checkers. Modules, interfaces, and programs shall not be instantiated inside checkers.

All checker formal arguments are inputs and they are processed in a similar way as property formal arguments, but the data types of checker formal arguments besides those legal for a property (see [16.13](#)), may also be **string** and non-integer types (**shortreal**, **real**, and **realtime**). Unlike modules, interfaces, and programs, checker formal arguments may not be connected to interfaces.

Below are examples of simple checkers:

Example 1:

```
// Simple checker containing concurrent assertions
checker my_check1 (logic test_sig, event clock);
  default clocking @clock; endclocking
  property p(logic sig);
  ...
  endproperty
  a1: assert property (p (test_sig));
  c1: cover property (!test_sig ##1 test_sig);
endchecker : my_check1
```

Example 2:

```
// Simple checker containing deferred assertions
checker my_check2 (logic a, b);
  a1: assert #0 ($onehot0({a, b}));
  c1: cover #0 (a == 0 && b == 0);
  c2: cover #0 (a == 1);
  c3: cover #0 (b == 1);
endchecker : my_check2
```

Type and data declarations within the checker are local to the checker scope and are static. Clock and **disable iff** contexts are inherited from the scope of the checker declaration (but see [17.4](#) for usage of context value functions for passing the instantiation context to the checker). For example:

```
module m;
  default clocking @clk1; endclocking
  default disable iff rst1;
  checker c1;
  // Inherits @clk1 and rst1
  ...
  endchecker : c1
  checker c2;
  // Explicitly redefines its default values
  default clocking @clk2; endclocking
  default disable iff rst2;
  ...
  endchecker : c2
  ...
endmodule : m
```

Variables used in a checker that are neither formal arguments to the checker nor internal variables of the checker are resolved according to the scoping rules from the scope in which the checker is declared.

17.3 Checker instantiation

```

concurrent_assertion_item ::=                                     //from A.2.10
...
| checker_instantiation
checker_instantiation ::=                                       //from A.4.1.4
  checker_identifier name_of_instance ( [list_of_checker_port_connections] ) ;
list_of_checker_port_connections25 ::=
  ordered_checker_port_connection { , ordered_checker_port_connection }
  | named_checker_port_connection { , named_checker_port_connection }
ordered_checker_port_connection ::= { attribute_instance } [ property_actual_arg ]
named_checker_port_connection ::=
  { attribute_instance } . port_identifier [ ( [ property_actual_arg ] ) ]
  | { attribute_instance } . *
checker_identifier ::=                                          //from A.9.3
  identifier

```

25) The `.*` token shall appear at most once in a list of port connections.

Syntax 17-2—Checker instantiation syntax (excerpt from [Annex A](#))

A checker may be instantiated wherever a concurrent assertion may appear (see [16.15](#)) with the following exceptions: it shall be illegal to instantiate checkers in `fork...join`, `fork...join_any`, or `fork...join_none` blocks.

A checker has different behavior depending on whether it is instantiated inside or outside procedural code. A checker instantiation in procedural code is referred to as a *procedural checker instance*. A checker instantiation outside procedural code is referred to as a *static checker instance*. The differences in behavior are described in [17.3.1](#). (See [16.15.6](#) for the corresponding definitions of procedural and static assertion statements.)

When a checker is instantiated, actual arguments are passed to the checker. The mechanism for passing arguments to a checker is similar to the mechanism for passing arguments to a property (see [16.13](#)), and each formal argument shall be assigned the sampled value of its actual argument during the Preponed region of each time step, with the following exceptions and clarifications:

- If $\$$ is an actual argument to a checker instance, then the corresponding formal argument shall be untyped and each of its references either shall be an upper bound in a *cycle_delay_const_range_expression* or shall itself be an actual argument in an instance of a named sequence or property, or in a checker instance.
- If an actual argument contains any subexpression that is a `const` cast or automatic value from procedural code, then the corresponding formal argument shall be used only in static assertion statements (see [16.15.6](#)) or static checker instances within the checker. In such cases, the current value of each such subexpression shall be substituted before sampling the full actual argument, whenever a static assertion statement in the checker or a statically instantiated subchecker is added to the pending procedural assertion queue (see [16.15.6.1](#) and [17.3.1](#)).
- Arguments that cannot be sampled, such as events, sequences, and properties, are treated similarly to such arguments for sequences and properties (see [16.8](#)): they are substituted directly for the formal argument when it is used in statements or expressions within the checker.

- If the checker is instantiated within another checker, then all formal arguments are considered to be directly connected to their actual arguments, as in a module instantiation. This also means that if the actual argument is connected to a formal in the parent checker that uses a `const` cast or automatic value from procedural code, it shall only appear in static assertion statements or static checker instantiations.

Checker formal arguments may be connected to their actual arguments in ways similar to module ports (see [23.3.2](#)):

- Positional connections by port order.
- Named port connections using fully explicit connections.
- Named port connections using implicit connections.
- Named port connections using a wildcard port name.

17.3.1 Behavior of instantiated checkers

All contents of a checker instance other than static assertion statements are considered to exist during every time step, regardless of whether the checker is static or procedural. One copy of these contents exists for each instantiation. Immediate assertions, including deferred assertions, are handled normally as described in [16.3](#) and [16.4](#). Procedural concurrent assertion statements in a checker shall be treated just like other procedural assertion statements as described in [16.15.6](#). However, static concurrent assertion statements within a checker are treated as if they appear at the checker's instantiation point:

- If the checker is static, the assertion statements are continually monitored, and begin execution on any time step matching their initial clock event.
- If the checker is procedural, all static assertion statements in the checker are added to the pending procedural assertion queue for their process when the checker instantiation is reached in process execution, and then may mature or be flushed like any procedural concurrent assertion (see [16.15.6.2](#)).
- If the checker is statically instantiated inside another checker, any of its static assertions are treated as if instantiated in the parent checker, and thus will also be queued when an instantiation of its top-level ancestor in the checker hierarchy is visited in procedural code.

The following example illustrates this behavior:

```

checker c1(event clk, logic[7:0] a, b);
  logic [7:0] sum;
  always @(clk) begin
    sum <= a + 1'b1;
    p0: assert property (sum < `MAX_SUM);
  end
  p1: assert property (@clk sum < `MAX_SUM);
  p2: assert property (@clk a != b);
endchecker

module m(input logic rst, clk, logic en, logic[7:0] in1, in2,
  in_array [20:0]);
  c1 check_outside(posedge clk, in1, in2);
  always @(posedge clk) begin
    automatic logic [7:0] v1=0;
    if (en) begin
      // v1 is automatic, so current procedural value is used
      c1 check_inside(posedge clk, in1, v1);
    end
    for (int i = 0; i < 4; i++) begin
      v1 = v1+5;
    end
  end

```



```
        if (i != 2) begin
            // v1 is automatic, so current procedural value is used
            c1 check_loop(posedge clk, in1, in_array[v1]);
        end
    end
end
endmodule : m
```

In this example, there are three instantiations of `c1`: `check_outside`, `check_inside`, and `check_loop`. They have the following characteristics:

- `check_outside` is a static instantiation, while `check_inside` and `check_loop` are procedural.
- Each of the three instantiations has its own version of `sum`, which is updated at every positive clock edge, regardless of whether that instance was visited in procedural code. Even in the case of `check_loop`, there is only one instance of `sum`, and it will be updated using the sampled value of `in1`.
- Each of the three instantiations will queue an evaluation of `p0` at every posedge of the clock (according to the rules in [16.15.6](#)), which will mature and report a violation during any time step when `sum` is not less than `MAX_SUM`, regardless of the behavior of the procedural code in module `m`.
- For instance `check_outside`, `p1` and `p2` are checked at every positive clock edge. For instance `check_inside`, `p1` and `p2` are queued to mature and be checked on any positive clock edge when `en` is true. For `check_loop`, three procedural instances of `p1` and `p2` are queued to mature on any positive clock edge. For `p1`, all three instances are identical, using the sampled value of `sum`; but for `p2`, the three instances compare the sampled value of `in1` to the sampled value of `in_array` indexed by constant `v1` values of 5, 10, and 20 respectively.

17.3.2 Nested checker instantiations

As described above, a checker instantiated in another checker is treated as if each of its formal arguments is directly connected to the corresponding actual argument, as in a module instantiation. However, a checker shall be evaluated statically or procedurally depending on its placement in the parent checker, and all restrictions on the usage of arguments given in [17.3](#) apply. The following example illustrates this behavior:

```
checker c3(event clk, logic a);
    p3: assert property (@clk a);
endchecker
checker c2(event clk, logic a);
    c3 c3_stat(clk, a);
    always @(clk) begin
        c3 c3_proc(clk, a); // ILLEGAL if c2 is instantiated as below
    end
endchecker

module m2(logic clk, logic [3:0] d);
    always @(posedge clk) begin
        for (int i = 0; i < 4; i++) begin
            c2 check_loop(posedge clk, d [const'(i)]);
        end
    end
endmodule : m2
```

In module `m2`, during each posedge of `clk`, checker `c2` will be visited four times, and four pending instances of assertion `c2.c3_stat.p3`, with current procedural values of `d[0]`, `d[1]`, `d[2]`, and `d[3]` for the value of `a`, will be queued and mature. However, since `c3_proc` is in the continually-executing procedural code of the checker, its use of the input `a`, which is connected to an expression containing a `const` cast subexpression in this instantiation, is illegal.

17.4 Context inference

Context value functions (see [16.15.7](#)) may be used as default values of formal arguments in a checker declaration. These functions enable adjusting the checker behavior depending on its instantiation context. For example:

```
// Context inference in a checker
checker check_in_context (logic test_sig,
                        event clock = $inferred_clock,
                        logic reset = $inferred_disable);
  property p(logic sig);
  ...
endproperty
a1: assert property (@clock disable iff (reset) p(test_sig));
c1: cover property (@clock !reset throughout !test_sig ##1 test_sig);
endchecker : check_in_context

module m(logic rst);
  wire clk;
  logic a, en;
  wire b = a && en;
  // No context inference
  check_in_context my_check1(.test_sig(b), .clock(clk), .reset(rst));
  always @(posedge clk) begin
    a <= ...;
    if (en) begin
      ...
      // inferred from context:
      // .clock(posedge clk)
      // .reset(1'b0)
      check_in_context my_check2(a);
    end
    en <= ...;
  end
endmodule : m
```

In the above example the default values of `clock` and `reset` in `check_in_context` are taken from the instantiation context. In the instantiation `my_check1` all formal arguments are provided explicitly. In the instantiation `my_check2` all optional arguments are passed their default value: the clock is inferred from the clock of the `always` procedure of the module `m`, the disable condition is inferred to be `1'b0`.

17.5 Checker procedures

The following procedures are allowed inside a checker body:

- **initial** procedure
- **always** procedure
- **final** procedure

An **initial** procedure in a checker body may contain deferred and concurrent assertions and a procedural timing control statement using an event control only.

An **always** procedure in a checker body may contain deferred and concurrent assertions, nonblocking variable assignments (see [17.7.1](#)) and a procedural timing control statement using an event control. All other statements shall not appear inside an **always** procedure.

A **final** procedure may be specified within a checker in the same manner as in a module (see [9.2.3](#)). This allows for the checker to check conditions with immediate assertions or print out statistics at the end of simulation. The operation of the **final** procedure is independent of the instantiation context of the checker that contains it. It will be executed once at the end of simulation for every instantiation of that checker. There is no implied ordering in the execution of multiple **final** procedures. A **final** procedure within a checker may include any construct which is allowed in a non-checker **final** procedure.

17.6 Covergroups in checkers

One or more **covergroup** declarations or instances (see [19.3](#)) are permitted within a checker. These declarations and instances shall not appear in any procedural block in the checker. A **covergroup** may reference any variable visible in its scope, including checker formal arguments and checker variables. However, it shall be an error if a formal argument referenced by a **covergroup** has a **const** actual argument. For example:

```
checker my_check(logic clk, active);
  bit active_d1 = 1'b0;

  always @(posedge clk) begin
    active_d1 <= active;
  end

  covergroup cg_active @(posedge clk);
    cp_active : coverpoint active
    {
      bins idle = { 1'b0 };
      bins active = { 1'b1 };
    }
    cp_active_d1 : coverpoint active_d1
    {
      bins idle = { 1'b0 };
      bins active = { 1'b1 };
    }
    option.per_instance = 1;
  endgroup
  cg_active cg_active_1 = new();
endchecker : my_check
```

A covergroup may also be triggered by a procedural call to its `sample()` method (see [19.8](#)). The following examples show how the `sample()` method may be called from a sequence match item to trigger a covergroup.

```
checker op_test (logic clk, vld_1, vld_2, logic [3:0] opcode);
  bit [3:0] opcode_d1;

  always @(posedge clk) opcode_d1 <= opcode;

  covergroup cg_op;
    cp_op : coverpoint opcode_d1;
  endgroup: cg_op
  cg_op cg_op_1 = new();

  sequence op_accept;
    @(posedge clk) vld_1 ##1 (vld2, cg_op_1.sample());
  endsequence
  cover property (op_accept);
endchecker
```

In this example, the coverpoint `cp_op` refers to the checker variable `opcode_d1` directly. It is triggered by a call to the default `sample()` method from a sequence match item. This function call occurs in the Reactive region, while nonblocking assignments to checker variables will occur in the Re-NBA region. As a result, the covergroup will sample the old value of the checker variable `opcode_d1`.

It is also possible to define a custom `sample()` method for a covergroup (see [19.8.1](#)). The following is an example of this:

```

checker op_test (logic clk, vld_1, vld_2, logic [3:0] opcode);
  bit [3:0] opcode_d1;

  always @(posedge clk) opcode_d1 <= opcode;

  covergroup cg_op with function sample(bit [3:0] opcode_d1);
    cp_op : coverpoint opcode_d1;
  endgroup: cg_op
  cg_op cg_op_1 = new();

  sequence op_accept;
    @(posedge clk) vld_1 ##1 (vld2, cg_op_1.sample(opcode_d1));
  endsequence
  cover property (op_accept);
endchecker

```

In this example, a custom `sample()` method has been defined for the covergroup `cg_op`, and the coverpoint `cp_op` references the formal argument of the custom `sample()` method. This custom method will be called in the Reactive region upon a sequence match, but the sampled value of the sequential checker variable `opcode_d1` will be passed to the `sample()` function. As a result, the covergroup will sample the value from the Preponed region.

17.7 Checker variables

Variables may be defined in checkers, but defining nets in the checker body shall be illegal. All variables defined in a checker body shall have static lifetime (see [17.2](#)). The variables defined in the checker body are referred to as *checker variables*. The following example illustrates checker variable usage:

```

checker counter_model(logic flag);
  bit [2:0] counter = '0;
  always @$global_clock
    counter <= counter + 1'b1;
  assert property (@$global_clock counter == 0 |-> flag);
endchecker : counter_model

```

Checker variables may have an optional **rand** qualifier. In this case, they are called *free variables*; free variables may behave non-deterministically.

Formal analysis tools shall take into account all possible values of the free checker variables imposed by the assumptions and assignments (see [17.7.1](#)). Simulators shall assign random values to the free variables as explained in [17.7.2](#).

The following example shows how free variables can be used for modeling for formal verification:

```

checker observer_model(bit valid, reset);
  default clocking @$global_clock; endclocking
  rand bit flag;

```

```

m1: assume property (reset | => !flag);
m2: assume property (!reset && flag | => flag);
m3: assume property ($rising_gclk(flag) | -> valid);
endchecker : observer_model

```

In this example, the following constraints are imposed on the free variable `flag`:

- If it is high, it remains high as long as there is no `reset`.
- If there is a `reset`, it becomes low at the next tick of the clock.
- It may rise only when `valid` is high.

Although the behavior of the free variable `flag` has been restricted by the assumptions `m1`, `m2`, and `m3`, it is still non-deterministic because it does not have to rise when `valid` is high. [Figure 17-1](#) shows two possible legal behaviors of this variable given the same behaviors of `reset` and `valid`. Formal analysis tools shall take all possible legal behaviors of `flag` into account. Simulators shall assign random values to the variable `flag` as explained in [17.7.2](#).

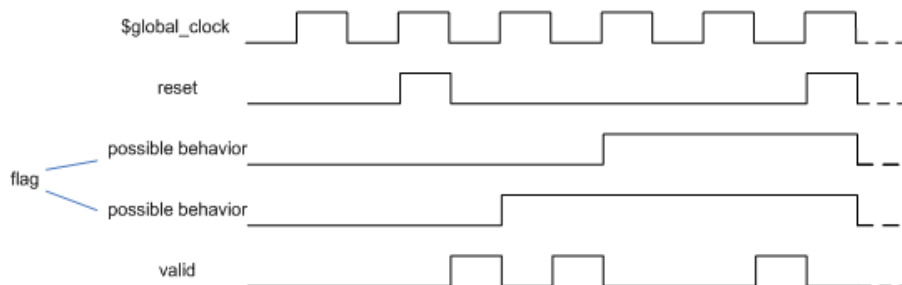

Figure 17-1—Non-deterministic free checker variable

The following example shows how free variables may be used to implement a nondeterministic choice:

```

// a may assume values 3 and 5 only
rand bit r;
let a = r ? 3'd3 : 3'd5;

```

A free variable declaration may have a `const` qualifier. If a constant free variable is initialized, it retains its initial value forever. An uninitialized constant free variable has a non-deterministic value at the initialization, and this value does not change. The following examples demonstrate the usage of constant free checker variables.

Formal analysis tools shall take into account any possible values of a constant free checker variable consistent with the imposed assumptions. Simulators shall assign a random constant value to a constant free variable as explained in [17.7.2](#).

Examples:

Reasoning about a representative bit:

```

checker reason_about_one_bit(bit [63:0] data1, bit [63:0] data2,
                             event clock);
    rand const bit [5:0] idx;
    a1: assert property (@clock data1[idx] == data2[idx]);
endchecker : reason_about_one_bit

```

In this example the assertion `a1` states that any fixed bit of `data1` has the same value as the corresponding bit of `data2`. Therefore, the checker `reason_about_one_bit` is equivalent in formal verification to the following checker (these two checkers are not equivalent in simulation):

```
checker reason_about_all_bit(bit [63:0] data1, bit [63:0] data2,
                             event clock);
    a1: assert property (@clock data1 == data2);
endchecker : reason_about_all_bit
```

The second realization of the checker compares two 64 bit values while the first one compares only one bit values, for every possible index. The first version may be more efficient for some formal tools.

Data integrity checking:

```
// If start_ev is asserted then the value of out_data at the next assertion
// of end_ev has to be equal to the current value of in_data at start_ev.
//
// It is assumed that in_data and out_data have the same size
checker data_legal(start_ev, end_ev, in_data, out_data);
    rand const bit [$bits(in_data)-1:0] mem_data;
    sequence transaction;
        start_ev && (in_data == mem_data) ##1 end_ev[->1];
    endsequence
    a1: assert property (@clock transaction |-> out_data == mem_data);
endchecker : data_legal
```

Since `mem_data` is a constant free variable, if `in_data` is equal to `mem_data` at the beginning of the transaction, then `mem_data` records that value and keeps it throughout the trace. In particular, at the end of the transaction, `mem_data` still holds that value and the assertion checks that it is equal to `out_data`. Moreover, `mem_data` was initialized with a non-deterministic value; it follows that for every value of `in_data`, there exists a computation in which `mem_data` is equal to that value of `in_data`, which in turn implies that the corresponding legality of data transfer through that transaction is being checked for formal verification. In simulation `mem_data` will be randomly initialized (see [17.7.2](#)), and it will only be checked that if at the transaction beginning `in_data` equals to `mem_data` then at the transaction end `out_data` will have the same value as `in_data` at the beginning of the transaction.

The latter example may be rewritten for formal verification using local variables instead of constant free variables (see [16.10](#); these implementations are not equivalent in simulation):

```
// If start_ev is asserted then the value of in_data has to be
// equal to the value of out_data at the next assertion of end_ev
//
// It is assumed that in_data and out_data have the same size
checker data_legal_with_loc(start_ev, end_ev, in_data, out_data);
    sequence transaction (loc_var);
        (start_ev, loc_var = in_data) ##1 end_ev[->1];
    endsequence
    property data_legal;
        bit [$bits(in_data)-1:0] mem_data;
        transaction(mem_data) |-> out_data == mem_data;
    endproperty
    a1: assert property (@clock data_legal);
endchecker : data_legal_with_loc
```

There is a difference between a constant and a non-constant free variable: a constant free variable does not change its value, while a non-constant free variable can assume a new value any time. If a non-constant free

variable has been initialized but is never assigned then it can assume any value at any time step in formal verification, or be randomized in subsequent time steps in simulation (see [17.7.2](#)), except the first one where its value is defined by the initialization. Consider the following declaration:

```
rand bit a = 1'b0, b;
```

The free variable *a* has initial value 0, but in other time steps its value may change. The free checker variable *b* may assume any value 0 or 1 at any time (in formal verification or randomized in simulation), as opposed to an uninitialized constant free checker variable, which keeps one specific value.

17.7.1 Checker variable assignments

Checker variables may be assigned using nonblocking procedural assignment only. Blocking procedural assignments to checker variables are not allowed. The formal semantics of free variable assignment is described in [F.3.4.6](#).

The following example illustrates usage of free variable assignments.

```
// Toggling variable:
// a may have either 0101... or 1010... pattern
rand bit a;
always @clk a <= !a;
```

The right-hand side of a checker variable assignment may contain the sequence method triggered (see [16.14.6](#)).

The following rules apply to both regular and free checker variables:

- It shall be illegal to reference a checker variable using its hierarchical name in assignments (see [23.6](#)). For example:

```
checker check(...)
  bit a;
  ...
endchecker

module m(...)
  ...
  check my_check(...);
  ...
  wire x = my_check.a; // Illegal
  bit y;
  ...
  always @(posedge clk) begin
    my_check.a = y; // Illegal
  ...
  end
  ...
endmodule
```

- Single Assignment Rule (SAR): it shall be illegal to use the same bit of a checker variable in several assignment-like contexts.

Example 1:

```
bit [2:0] a;
...
bit [2:0] b;
```

```

always @(posedge clk) begin
    b[1:0] <= a[1:0];
    b[2:1] <= a[2:1]; // Illegal: SAR violation
end

```

This is illegal because there are two assignment statements to `b[1]` (even though the two assignments are to the same value).

Example 2:

```

bit [2:0] a;
...
bit [2:0] b;
always @(posedge clk) begin
    b[1:0] <= a[2:1];
    b[2] <= a[0];
end

```

This is legal because each bit of `b` is assigned only once.

- The left hand side of an assignment shall be the longest static prefix of a select (see [11.5.3](#)). For example:

```

rand bit [3:0] a;
rand bit [1:0] i;
always @clk
    a[i] <= !a[i]; // Illegal

```

- A checker variable may not be assigned in an `initial` procedure. For example:

```

bit v;
initial v <= 1'b0; // Illegal

```

17.7.2 Checker variable randomization with assumptions

Checker `assume` statements are used to describe assumptions that may be made about the values of variables. They may be used by simulators to constrain the random generation of free checker variable values or by formal tools to constrain the formal computation. As with normal `assume` statements, checker `assume` statements shall also be checked for violation during simulation.

Assume-based checker variable randomization is the process of periodically solving a set of properties appearing in `assume` statements (called an *assume set*) to find satisfying values for the free checker variables, and updating those variables with the newfound values. Unlike class-based constrained random generation, solving is triggered by any of the clock events of the properties in the assume set (called an *assume set clock event*) rather than by an explicit procedural call [e.g., there is no `randomize()` for checkers]. Once updated with solution values, free checker variables shall remain constant until the next assume set clock event or the end of the time step, whichever comes first.

All non-`const` free checker variables are treated as either active or inactive for assume-based randomization, in the same way as `rand` variables for class-based constrained random generation (see [17.9](#)), but without an explicit control facility [such as `rand_mode()`]. All other variables (such as non-free checker variables and checker formals) are always treated as inactive. Any free checker variables that appear on the left-hand side of a checker variable assignment (see [17.7.1](#)) are inactive; all other free checker variables are active. Free checker variables are active or inactive for each singular element of the variable. For example, a packed array or structure is active or inactive monolithically, whereas the elements of an unpacked array or structure are separately active or inactive.

All free checker variables, both `const` and non-`const`, active and inactive, are initialized with unconstrained random values unless explicitly initialized in their declaration.

Each checker instance has one and only one assume set, which may be empty. Like checker procedures and variables, checker assume sets are considered to exist at every time step, regardless of whether the checker instance is static or procedural (see [17.3](#)).

The assume set of a checker instance is formed from the checker **assume** statements and child checker **assume** statements. Any of these **assume** statements that references a formal whose actual argument contains any subexpression that is a **const** cast or automatic value (see [17.3](#)) is excluded from the assume set. This restriction allows a single copy of the assume set to exist for each instantiation that is valid for the entire simulation, as described in [17.3.1](#). Among the remaining **assume** statements, those that reference active free variables of the checker are included in the assume set. For example:

```

module my_mod();
  bit mclk, v1, v2;
  checker c1(bit fclk, bit a, bit b);
    default clocking @ (posedge fclk); endclocking
  checker c2(bit bclk, bit x, bit y);
    default clocking @ (posedge bclk); endclocking
    rand bit m, n;
    u1: assume property (f1(x,m));
    u2: assume property (f2(y,n));
  endchecker
  rand bit q, r;
  c2 B1(fclk, q+r, r);
  always @ (posedge fclk)
    r <= a || q; // assignment makes r inactive
  u3: assume property (f3(a, q));
  u4: assume property (f4(b, r));
endchecker
  ...
  c1 F1(mclk, v1, const'(v2));
endmodule

```

The assume set of F1 consists of F1.u3 and F1.B1.u1. The property F1.B1.u1 is included because it references the formal *x*, whose actual expression *q+r* involves an active free checker variable. F1.u4 is excluded because it references the formal *b*, which is associated with the **const** cast actual *v2*. F1.B1.u2 is excluded because the only formal referenced is *y*, which is not associated with an active free variable actual (the actual *r* is inactive). However, checker instance F1.B1 has its own assume set, which includes *u2* as well as *u1*; neither of those **assume** statements involve formals with **const** cast or automatic actuals.

When a solution attempt is made on an assume set, values shall be sought for all active checker variables such that, together with the inactive variables and state, none of the assumptions will fail in that time step. If a set of such values is found, the solution attempt is successful. Otherwise, any values may be chosen for the active variables and the solution attempt is unsuccessful. There is no requirement that a solution be found if it exists or that “dead end” states (states where no solution exists) be avoided. For example,

```

u_deadend: assume property (@(posedge clk) x |=> ##5 1'b0);

```

If the value 1 is chosen for *x*, the property would not fail in the current time step; however, it would inevitably fail six clock cycles later. Such an inevitable future failure is called a *dead end*. Despite the dead end, selecting 1 for *x* is considered a successful solution attempt.

Empty assume sets shall be considered to have an implicit assume set clock event in every time step before the Observed region. Active variables in checkers with empty assume sets are called *implicitly clocked* active free variables; those with non-empty assume sets are *explicitly clocked*. Implicitly clocked active variables may be updated with unconstrained random values at every time step. Once updated, the variables stay constant until the end of the time step.

Active variables that do not appear in any property in a non-empty assume set are unconstrained but explicitly clocked. They may be updated with random values at every assume set clock event.

When an implementation is about to begin the Observed region, it shall solve for all the active free variables. When solving, non-active variables are either sampled or not as described in [17.3](#). Checker procedures and properties shall not use sampled values of active free checker variables; current values shall be read so that up-to-date solved values are visible. Note that checker procedures and properties execute in the Reactive and Observed regions (see [17.7.3](#)), and so have the new values available.

When a solution attempt is unsuccessful, any resulting assumption failure(s) do not occur until an unsatisfied property is clocked and checked in the Observed region.

17.7.3 Scheduling semantics

Statements and constructs within a checker that are sensitive to changes (e.g., clocking events) are scheduled in the Reactive region (similarly to programs, see [24.3.1](#)). The nonblocking assignments of checker variables schedule their updates in the Re-NBA region. The Re-NBA region is processed after the Reactive and Re-Inactive regions have been emptied of events. See [4.2](#). These scheduling rules make possible assignment of sequence endpoint values to checker variables. For example:

```
checker my_check(...);
...
sequence s; ...; endsequence
always @clk a <= s.triggered;
endchecker
```

For every transition of signal `clk`, the simulator will update the variable `a` in the Re-NBA region with the value of `s.triggered` captured in the Reactive region. Had the checker captured the value of `s.triggered` in the Active region, `a` would always be assigned `1'b0`, since `s.triggered` is evaluated in the Observed region, and the above code would be meaningless.

Concurrent assertions have invariant scheduling semantics, whether present in checker code or design code.

17.8 Functions in checkers

While procedural statements (`if`, `case`, etc.) may not be placed directly in the `initial` and in the `always` procedures, they may be used in functions called from the right-hand side of a checker variable assignment. The formal arguments and internal variables of functions used in checkers shall not be declared as free variables. However, free variables are allowed to be passed in as actual arguments to a function.

Expressions at the right hand side of checker variable assignments are allowed to include function calls with the same restrictions that are imposed on function calls in concurrent assertions (see [16.6](#)):

- Functions that appear in expressions shall not contain `output` or `ref` arguments (`const ref` is allowed).
- Functions shall be automatic (or preserve no state information) and have no side effects.

See an example of a function used in a checker in [17.9](#).

17.9 Complex checker example

The checker in the following example makes sure that the expression is true in a window delimited by `start_event` and `end_event`.

```
typedef enum { cover_none, cover_all } coverage_level;
checker assert_window (
    logic test_expr,          // Expression to be true in the window
    sequence start_event,    // Window opens at the completion of the start_event
    sequence end_event,      // Window closes at the completion of the end_event
    event clock = $inferred_clock,
    logic reset = $inferred_disable,
    string error_msg = "violation",
    coverage_level clevel = cover_all
);

default clocking @clock; endclocking
default disable iff reset;
bit window = 0;
let start_flag = start_event.triggered;
let end_flag = end_event.triggered;

// Compute next value of window
function bit next_window (bit win);
    if (reset || win && end_flag == 1'b1)
        return 1'b0;
    if (!win && start_flag == 1'b1)
        return 1'b1;
    return win;
endfunction

always @(clock)
    window <= next_window(window);

property p_window;
    start_flag && !window | => test_expr[*1:$] ##0 end_flag;
endproperty

a_window: assert property (p_window) else $error(error_msg);

generate if (coverage_level != cover_none) begin : cover_b
    cover_window_open: cover property (start_flag && !window)
        $display("win_open_covered");

    cover_window: cover property (
        start_flag && !window
        ##1 (!end_flag && window) [*0:$]
        ##1 end_flag && window
    ) $display("window covered");
end : cover_b
endgenerate
endchecker : assert_window
```

18. Constrained random value generation

18.1 General

This clause describes the following:

- Random variables
- Constraint blocks
- Randomization methods
- Disabling randomization
- Controlling constraints
- Scope variable randomization
- Seeding the random number generator
- Random weighted case statements
- Random sequence generation

18.2 Overview

Constraint-driven test generation allows users to automatically generate tests for functional verification. Random testing can be more effective than a traditional, directed testing approach. By specifying constraints, one can easily create tests that can find hard-to-reach corner cases. SystemVerilog allows users to specify constraints in a compact, declarative way. The constraints are then processed by a solver that generates random values that meet the constraints.

The random constraints are typically specified on top of an object-oriented data abstraction that models the data to be randomized as objects that contain random variables and user-defined constraints. The constraints determine the legal values that can be assigned to the random variables. Objects are ideal for representing complex aggregate data types and protocols such as Ethernet packets.

Subclause [18.3](#) provides an overview of object-based randomization and constraint programming. The rest of this clause provides detailed information on random variables, constraint blocks, and the mechanisms used to manipulate them.

18.3 Concepts and usage

This subclause introduces the basic concepts and uses for generating random stimulus within objects. SystemVerilog uses an object-oriented method for assigning random values to the member variables of an object, subject to user-defined constraints. For example:

```
class Bus;
    rand bit[15:0] addr;
    rand bit[31:0] data;

    constraint word_align {addr[1:0] == 2'b0;}
endclass
```

The `Bus` class models a simplified bus with two random variables: `addr` and `data`, representing the address and data values on a bus. The `word_align` constraint declares that the random values for `addr` must be such that `addr` is word-aligned (the low-order 2 bits are 0).

The `randomize()` method is called to generate new random values for a bus object:

```
Bus bus = new;

repeat (50) begin
  if ( bus.randomize() == 1 )
    $display ("addr = %16h data = %h\n", bus.addr, bus.data);
  else
    $display ("Randomization failed.\n");
end
```

Calling `randomize()` causes new values to be selected for all of the random variables in an object so that all of the constraints are true (satisfied). In the program test above, a `bus` object is created and then randomized 50 times. The result of each randomization is checked for success. If the randomization succeeds, the new random values for `addr` and `data` are printed; if the randomization fails, an error message is printed. In this example, only the `addr` value is constrained, while the `data` value is unconstrained. Unconstrained variables are assigned any value in their declared range.

Constraint programming is a powerful method that lets users build generic, reusable objects that can later be extended or constrained to perform specific functions. The approach differs from both traditional procedural and object-oriented programming, as illustrated in this example that extends the `Bus` class:

```
typedef enum {low, mid, high} AddrType;

class MyBus extends Bus;
  rand AddrType atype;
  constraint addr_range
  {
    (atype == low ) -> addr inside { [0 : 15] };
    (atype == mid ) -> addr inside { [16 : 127]};
    (atype == high) -> addr inside {[128 : 255]};
  }
endclass
```

The `MyBus` class inherits all of the random variables and constraints of the `Bus` class and adds a random variable called `atype` that is used to control the address range using another constraint. The `addr_range` constraint uses implication to select one of three range constraints depending on the random value of `atype`. When a `MyBus` object is randomized, values for `addr`, `data`, and `atype` are computed so that all of the constraints are satisfied. Using inheritance to build layered constraint systems enables the development of general-purpose models that can be constrained to perform application-specific functions.

Objects can be further constrained using the `randomize()` **with** construct, which declares additional constraints in line with the call to `randomize()`:

```
task exercise_bus (MyBus bus);
  int res;

  // EXAMPLE 1: restrict to low addresses
  res = bus.randomize() with {atype == low;};

  // EXAMPLE 2: restrict to address between 10 and 20
  res = bus.randomize() with {10 <= addr && addr <= 20;};

  // EXAMPLE 3: restrict data values to powers-of-two
  res = bus.randomize() with {(data & (data - 1)) == 0;};
endtask
```

This example illustrates several important properties of constraints, as follows:

- Constraints can be any SystemVerilog expression with variables and constants of integral type (e.g., **bit**, **reg**, **logic**, **integer**, **enum**, **packed struct**).
- The constraint solver shall be able to handle a wide spectrum of equations, such as algebraic factoring, complex Boolean expressions, and mixed integer and bit expressions. In the example above, the power-of-two constraint was expressed arithmetically. It could have also been defined with expressions using a shift operator. For example, $1 \ll n$, where n is a 5-bit random variable.
- If a solution exists, the constraint solver shall find it. The solver can fail only when the problem is over-constrained and there is no combination of random values that satisfy the constraints.
- Constraints interact bidirectionally. In this example, the value chosen for `addr` depends on `atype` and how it is constrained, and the value chosen for `atype` depends on `addr` and how it is constrained. All expression operators are treated bidirectionally, including the implication operator (`->`).
- Constraints support only 2-state values. The 4-state values (`x` or `z`) or 4-state operators (e.g., `===`, `!==`) are illegal and shall result in an error.

Sometimes it is desirable to disable constraints on random variables. For example, to deliberately generate an illegal address (nonword-aligned):

```
task exercise_illegal(MyBus bus, int cycles);
    int res;

    // Disable word alignment constraint.
    bus.word_align.constraint_mode(0);

    repeat (cycles) begin

        // CASE 1: restrict to small addresses.
        res = bus.randomize() with {addr[0] || addr[1]};
        ...
    end

    // Reenable word alignment constraint
    bus.word_align.constraint_mode(1);
endtask
```

The `constraint_mode()` method can be used to enable or disable any named constraint block in an object. In this example, the word-alignment constraint is disabled, and the object is then randomized with additional constraints forcing the low-order address bits to be nonzero (and thus unaligned).

The ability to enable or disable constraints allows users to design constraint hierarchies. In these hierarchies, the lowest level constraints can represent physical limits grouped by common properties into named constraint blocks, which can be independently enabled or disabled.

Similarly, the `rand_mode()` method can be used to enable or disable any random variable. When a random variable is disabled, it behaves in exactly the same way as other nonrandom variables.

Occasionally, it is desirable to perform operations immediately before or after randomization. That is accomplished via two built-in methods, `pre_randomize()` and `post_randomize()`, which are automatically called before and after randomization. These methods can be overridden with the desired functionality:

```
class XYPair;
    rand integer x, y;
endclass
```

```

class MyXYPair extends XYPair
  function void pre_randomize();
    super.pre_randomize();
    $display("Before randomize x=%0d, y=%0d", x, y);
  endfunction

  function void post_randomize();
    super.post_randomize();
    $display("After randomize x=%0d, y=%0d", x, y);
  endfunction
endclass

```

By default, `pre_randomize()` and `post_randomize()` call their overridden base class methods. When `pre_randomize()` or `post_randomize()` are overridden, care must be taken to invoke the base class's methods, unless the class is a base class (has no base class). Otherwise, the base class methods shall not be called.

The random stimulus generation capabilities and the object-oriented constraint-based verification methodology enable users to quickly develop tests that cover complex functionality and better assure design correctness.

18.4 Random variables

Class variables can be declared random using the **rand** and **randc** type-modifier keywords.

The syntax to declare a random variable in a class is as follows in [Syntax 18-1](#).

```

class_property ::= // from A.1.9
  { property_qualifier } data_declaration
property_qualifier8 ::=
  random_qualifier
  | class_item_qualifier
random_qualifier8 ::=
  rand
  | randc

```

8) In any one declaration, only one of **protected** or **local** is allowed, only one of **rand** or **randc** is allowed, and **static** and/or **virtual** can appear only once.

Syntax 18-1—Random variable declaration syntax (excerpt from [Annex A](#))

- The solver can randomize singular variables of any integral type.
- Arrays can be declared **rand** or **randc**, in which case all of their member elements are treated as **rand** or **randc**.
- Individual array elements can be constrained, in which case the index expression may include iterative constraint loop variables, constants, and state variables.
- Dynamic arrays, associative arrays and queues can be declared **rand** or **randc**. All of the elements in the array are randomized, overwriting any previous data.

- The size of a dynamic array or queue declared as **rand** or **randc** can also be constrained. In that case, the array shall be resized according to the size constraint, and then all the array elements shall be randomized. The array size constraint is declared using the `size` method. For example:

```
rand bit [7:0] len;
rand integer data[];
constraint db { data.size == len; }
```

The variable `len` is declared to be 8 bits wide. The randomizer computes a random value for the `len` variable in the 8-bit range of 0 to 255 and then randomizes the first `len` elements of the `data` array.

When a dynamic array is resized by `randomize`, the resized array is initialized (see 7.5.1) with the original array. When a queue is resized by `randomize`, elements are inserted or deleted (see 7.10.2.2 and 7.10.2.3) at the back (i.e., right side) of the queue as necessary to produce the new queue size; any new elements inserted take on the default value of the element type. That is, the resize grows or shrinks the array. This is significant for a dynamic array or queue of class handles. `Randomize` does not allocate any class objects. Up to the new size, existing class objects are retained and their content randomized. If the new size is greater than the original size, each of the additional elements has a **null** value requiring no randomization.

In resizing a dynamic array or queue by `randomize` or `new`, the `rand_mode` of each retained element is preserved and the `rand_mode` of each new element is set to active.

If a dynamic array's size is not constrained, then the array shall not be resized and all the array elements shall be randomized.

- An object handle can be declared **rand**, in which case all of that object's variables and constraints are solved concurrently with the variables and constraints of the object that contains the handle. Randomization shall not modify the actual object handle. Object handles shall not be declared **randc**.
- An unpacked structure can be declared **rand**, in which case all of that structure's random members are solved concurrently using one of the rules listed in this subclause. Unpacked structures shall not be declared **randc**. A member of an unpacked structure can be made random by having a **rand** or **randc** modifier in the declaration of its type. Members of unpacked structures containing a union as well as members of packed structures shall not be allowed to have a random modifier.

For example:

```
class packet;
typedef struct {
    randc int addr = 1 + constant;
    int crc;
    rand byte data [] = {1,2,3,4};
} header;
rand header h1;
endclass
packet p1=new;
```

18.4.1 Rand modifier

Variables declared with the **rand** keyword are standard random variables. Their values are uniformly distributed over their range. For example:

```
rand bit [7:0] y;
```

This is an 8-bit unsigned integer with a range of 0 to 255. If unconstrained, this variable shall be assigned any value in the range of 0 to 255 with equal probability. In this example, the probability of the same value repeating on successive calls to randomize is 1/256.

18.4.2 Randc modifier

Variables declared with the `randc` keyword are random-cyclic variables that cycle through all the values in a random permutation of their declared range.

To understand `randc`, consider a 2-bit random variable `y`:

```
randc bit [1:0] y;
```

The variable `y` can take on the values 0, 1, 2, and 3 (range of 0 to 3). Randomize computes an initial random permutation of the range values of `y` and then returns those values in order on successive calls. After it returns the last element of a permutation, it repeats the process by computing a new random permutation.

The basic idea is that `randc` randomly iterates over all the values in the range and that no value is repeated within an iteration. When the iteration finishes, a new iteration automatically starts (see [Figure 18-1](#)).

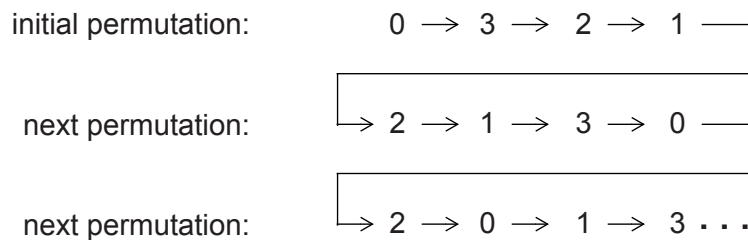

Figure 18-1—Example of randc

The permutation sequence for any given `randc` variable is recomputed whenever the constraints change on that variable or when none of the remaining values in the permutation can satisfy the constraints. The permutation sequence shall contain only 2-state values.

To reduce memory requirements, implementations may impose a limit on the maximum size of a `randc` variable, but it shall be no less than 8 bits.

The semantics of random-cyclical variables requires that they be solved before other random variables. A set of constraints that includes both `rand` and `randc` variables shall be solved so that the `randc` variables are solved first, and this can sometimes cause `randomize()` to fail.

If a random variable is declared as `static`, the `randc` state of the variable shall also be static. Thus `randomize` chooses the next cyclic value (from a single sequence) when the variable is randomized through any instance of the base class.

18.5 Constraint blocks

The values of random variables are determined using constraint expressions that are declared using constraint blocks. Constraint blocks are class members, like tasks, functions, and variables. Constraint block names shall be unique within a class.

The syntax to declare a constraint block is as follows in [Syntax 18-2](#).

```

constraint_declaration ::= //from A.1.10
    [ static ] constraint constraint_identifier constraint_block
constraint_block ::= { { constraint_block_item } }
constraint_block_item ::=
    solve solve_before_list before solve_before_list ;
    | constraint_expression
solve_before_list ::= solve_before_primary { , solve_before_primary }
solve_before_primary ::= [ implicit_class_handle . | class_scope ] hierarchical_identifier select
constraint_expression ::=
    expression_or_dist ;
    | expression -> constraint_set
    | if ( expression ) constraint_set [ else constraint_set ]
    | foreach ( ps_or_hierarchical_array_identifier [ loop_variables ] ) constraint_set
constraint_set ::=
    constraint_expression
    | { { constraint_expression } }
dist_list ::= dist_item { , dist_item }
dist_item ::= value_range [ dist_weight ]
dist_weight ::=
    := expression
    | :/ expression
constraint_prototype ::= [constraint_prototype_qualifier] [ static ] constraint constraint_identifier ;
constraint_prototype_qualifier ::= extern | pure
extern_constraint_declaration ::=
    [ static ] constraint class_scope constraint_identifier constraint_block
identifier_list ::= identifier { , identifier }
expression_or_dist ::= expression [ dist { dist_list } ] //from A.2.10
loop_variables ::= [ index_variable_identifier ] { , [ index_variable_identifier ] } //from A.6.8

```

Syntax 18-2—Constraint syntax (excerpt from [Annex A](#))

The *constraint_identifier* is the name of the constraint block. This name can be used to enable or disable a constraint using the `constraint_mode()` method (see [18.9](#)).

The *constraint_block* is a list of expression statements that restrict the range of a variable or define relations between variables. A *constraint_expression* is any SystemVerilog expression or one of the constraint-specific operators, **dist** and **->** (see [18.5.4](#) and [18.5.5](#), respectively).

The declarative nature of constraints imposes the following restrictions on constraint expressions:

- Functions are allowed with certain limitations (see [18.5.11](#)).
- Operators with side effects, such as **++** and **--**, are not allowed.
- **randc** variables cannot be specified in ordering constraints (see **solve...before** in [18.5.9](#)).
- **dist** expressions cannot appear in other expressions.

18.5.1 External constraint blocks

Constraint blocks can be declared outside their enclosing class declaration if a *constraint prototype* appears in the enclosing class declaration. A constraint prototype specifies that the class shall have a constraint of the specified name, but does not specify a constraint block to implement that constraint. A constraint prototype can take either of two forms, as shown in the following example:

```
class C;  
  rand int x;  
  constraint proto1;           // implicit form  
  extern constraint proto2;   // explicit form  
endclass
```

For both forms the constraint can be completed by providing an *external constraint block* using the class scope resolution operator, as in the following example:

```
constraint C::proto1 { x inside {-4, 5, 7}; }  
constraint C::proto2 { x >= 0; }
```

An external constraint block shall appear in the same scope as the corresponding class declaration, and shall appear after the class declaration in that scope. If the explicit form of constraint prototype is used, it shall be an error if no corresponding external constraint block is provided. If the implicit form of prototype is used and there is no corresponding external constraint block, the constraint shall be treated as an empty constraint and a warning may be issued. An empty constraint is one that has no effect on randomization, equivalent to a constraint block containing the constant expression 1.

For either form, it shall be an error if more than one external constraint block is provided for any given prototype, and it shall be an error if a constraint block of the same name as a prototype appears in the same class declaration.

18.5.2 Constraint inheritance

Constraints follow the same general rules for inheritance as other class members. The `randomize()` method is virtual and therefore honors constraints of the object on which it was called, regardless of the data type of the object handle through which the method was called.

A derived class shall inherit all constraints from its superclass. Any constraint in a derived class having the same name as a constraint in its superclass shall replace the inherited constraint of that name. Any constraint in a derived class that does not have the same name as a constraint in the superclass shall be an additional constraint.

If a derived class has a constraint prototype with the same name as a constraint in its superclass, that constraint prototype shall replace the inherited constraint. Completion of the derived class's constraint prototype shall then follow the rules described in [18.5.1](#), above.

An abstract class (i.e., a class declared using the syntax **virtual class**, as described in [8.20](#)) may contain *pure constraints*. A pure constraint is syntactically similar to a constraint prototype but uses the **pure** keyword, as in the example below:

```
virtual class D;  
  pure constraint Test;  
endclass
```

A pure constraint represents an obligation on any non-abstract derived class (i.e., a derived class that is not **virtual**) to provide a constraint of the same name. It shall be an error if a non-abstract class does not have

an implementation of every pure constraint that it inherits. It shall be an error to declare a pure constraint in a non-abstract class.

It shall be an error if a class containing a pure constraint also has a constraint block, constraint prototype or external constraint block of the same name. However, any class (whether abstract or not) may contain a constraint block or constraint prototype of the same name as a pure constraint that the class inherits; such a constraint shall override the pure constraint, and shall be a non-pure constraint for the class and any class derived from it.

An abstract class that inherits a constraint from its superclass may have a pure constraint of the same name. In this case, the pure constraint in the derived virtual class shall replace the inherited constraint.

A constraint that overrides a pure constraint may be declared using a constraint block in the body of the overriding class, or may be declared using a constraint prototype and external constraint as described in [18.5.1](#).

18.5.3 Set membership

Constraints support integer value sets and the set membership operator (as defined in [11.4.13](#)).

Absent any other constraints, all values (either single values or value ranges) have an equal probability of being chosen by the **inside** operator.

The negated form of the **inside** operator denotes that expression lies outside the set: `!(expression inside { set })`.

For example:

```

rand integer x, y, z;
constraint c1 {x inside {3, 5, [9:15], [24:32], [y:2*y], z};}

rand integer a, b, c;
constraint c2 {a inside {b, c};}

integer fives[4] = '{ 5, 10, 15, 20 }';
rand integer v;
constraint c3 { v inside {fives}; }

```

In SystemVerilog, the **inside** operator is bidirectional; thus, the second example above is equivalent to `a == b || a == c`.

18.5.4 Distribution

In addition to set membership, constraints support sets of weighted values called *distributions*. Distributions have two properties: they are a relational test for set membership, and they specify a statistical distribution function for the results.

The syntax to define a distribution expression is as follows in [Syntax 18-3](#).

```

constraint_expression ::=
    expression_or_dist ;
    ...
dist_list ::= dist_item { , dist_item }

```

// from [A.1.10](#)

```

dist_item ::= value_range [ dist_weight ]
dist_weight ::=
    := expression
  | :/ expression
expression_or_dist ::= expression [ dist { dist_list } ]

```

// from A.2.10

Syntax 18-3—Constraint distribution syntax (excerpt from Annex A)

The *expression* can be any integral SystemVerilog expression.

The distribution operator **dist** evaluates to true if the value of the expression is contained in the set; otherwise, it evaluates to false.

Absent any other constraints, the probability that the expression matches any value in the list is proportional to its specified weight. If there are constraints on some expressions that cause the distribution weights on these expressions to be not satisfiable, implementations are only required to satisfy the constraints. An exception to this rule is a weight of zero, which is treated as a constraint.

The distribution set is a comma-separated list of integral expressions and ranges. Optionally, each term in the list can have a weight, which is specified using the := or :/ operators. If no weight is specified for an item, the default weight is := 1. The weight can be any integral SystemVerilog expression.

The := operator assigns the specified weight to the item or, if the item is a range, to every value in the range.

The :/ operator assigns the specified weight to the item or, if the item is a range, to the range as a whole. If there are *n* values in the range, the weight of each value is *range_weight* / *n*.

For example:

```
x dist {100 := 1, 200 := 2, 300 := 5}
```

means *x* is equal to 100, 200, or 300 with weighted ratio of 1-2-5. If an additional constraint is added that specifies that *x* cannot be 200,

```
x != 200;
x dist {100 := 1, 200 := 2, 300 := 5}
```

then *x* is equal to 100 or 300 with weighted ratio of 1-5.

It is easier to think about mixing ratios, such as 1-2-5, than the actual probabilities because mixing ratios do not have to be normalized to 100%. Converting probabilities to mixing ratios is straightforward.

When weights are applied to ranges, they can be applied to each value in the range, or they can be applied to the range as a whole. For example:

```
x dist { [100:102] := 1, 200 := 2, 300 := 5 }
```

means *x* is equal to 100, 101, 102, 200, or 300 with a weighted ratio of 1-1-1-2-5, and

```
x dist { [100:102] :/ 1, 200 := 2, 300 := 5 }
```

means *x* is equal to one of 100, 101, 102, 200, or 300 with a weighted ratio of 1/3-1/3-1/3-2-5.

In general, distributions guarantee two properties: set membership and monotonic weighting. In other words, increasing a weight increases the likelihood of choosing those values.

Limitations are as follows:

- A **dist** operation shall not be applied to **randc** variables.
- A **dist** expression requires that expression contain at least one **rand** variable.

18.5.5 Implication

Constraints provide two constructs for declaring conditional (predicated) relations: implication and **if-else**.

The implication operator (\rightarrow) can be used to declare an expression that implies a constraint.

The syntax to define an implication constraint is as follows in [Syntax 18-4](#).

```
constraint_expression ::= // from A.1.10
    ...
    | expression  $\rightarrow$  constraint_set
```

Syntax 18-4—Constraint implication syntax (excerpt from [Annex A](#))

The *expression* can be any integral SystemVerilog expression.

The Boolean equivalent of the implication operator $a \rightarrow b$ is $(!a \ || \ b)$. This states that if the expression is true, then random numbers generated are constrained by the constraint (or constraint set). Otherwise, the random numbers generated are unconstrained.

The *constraint_set* represents any valid constraint or an unnamed constraint set. If the expression is true, all of the constraints in the constraint set shall also be satisfied.

For example:

```
mode == little  $\rightarrow$  len < 10;
mode == big  $\rightarrow$  len > 100;
```

In this example, the value of `mode` implies that the value of `len` shall be constrained to less than 10 (`mode == little`), greater than 100 (`mode == big`), or unconstrained (`mode != little` and `mode != big`).

In the example

```
bit [3:0] a, b;
constraint c { (a == 0)  $\rightarrow$  (b == 1); }
```

both `a` and `b` are 4 bits; therefore, there are 256 combinations of `a` and `b`. Constraint `c` says that `a == 0` implies that `b == 1`, thereby eliminating 15 combinations: $\{0,0\}$, $\{0,2\}$, ... $\{0,15\}$. Therefore, the probability that `a == 0` is thus $1/(256-15)$ or $1/241$.

18.5.6 if-else constraints

The **if-else** style constraints are also supported.

The syntax to define an **if-else** constraint is as follows in [Syntax 18-5](#).

```
constraint_expression ::= // from A.1.10
...
| if ( expression ) constraint_set [ else constraint_set ]
```

Syntax 18-5—If-else constraint syntax (excerpt from [Annex A](#))

The *expression* can be any integral SystemVerilog expression.

The *constraint_set* represents any valid constraint or an unnamed constraint block. If the expression is true, all of the constraints in the first constraint or constraint set shall be satisfied; otherwise, all of the constraints in the optional **else** constraint or constraint block shall be satisfied. Constraint sets can be used to group multiple constraints.

The **if-else** style constraint declarations are equivalent to implications

```
if (mode == little)
  len < 10;
else if (mode == big)
  len > 100;
```

which is equivalent to

```
mode == little -> len < 10 ;
mode == big -> len > 100 ;
```

In this example, the value of `mode` implies that the value of `len` is less than 10, greater than 100, or unconstrained.

Just like implication, **if-else** style constraints are bidirectional. In the declaration above, the value of `mode` constrains the value of `len`, and the value of `len` constrains the value of `mode`.

Because the **else** part of an **if-else** style constraint declaration is optional, there can be confusion when an **else** is omitted from a nested **if** sequence. This is resolved by always associating the **else** with the closest previous **if** that lacks an **else**. In the example below, the **else** goes with the inner **if**, as shown by indentation:

```
if (mode != big)
  if (mode == little)
    len < 10;
  else // the else applies to preceding if
    len > 100;
```

18.5.7 Iterative constraints

Iterative constraints allow arrayed variables to be constrained using loop variables and indexing expressions, or by using array reduction methods.

18.5.7.1 foreach iterative constraints

The syntax to define a **foreach** iterative constraint is as follows in [Syntax 18-6](#).

```
constraint_expression ::= //from A.1.10
...
| foreach ( ps_or_hierarchical_array_identifier [ loop_variables ] ) constraint_set
loop_variables ::= [ index_variable_identifier ] { , [ index_variable_identifier ] } //from A.6.8
```

Syntax 18-6—Foreach iterative constraint syntax (excerpt from [Annex A](#))

The **foreach** construct specifies iteration over the elements of an array. Its argument is an identifier that designates any type of array (fixed-size, dynamic, associative, or queue) followed by a list of loop variables enclosed in square brackets. Each loop variable corresponds to one of the dimensions of the array.

For example:

```
class C;
  rand byte A[] ;

  constraint C1 { foreach ( A [ i ] ) A[i] inside {2,4,8,16}; }
  constraint C2 { foreach ( A [ j ] ) A[j] > 2 * j; }
endclass
```

C1 constrains each element of the array A to be in the set [2,4,8,16]. C2 constrains each element of the array A to be greater than twice its index.

The number of loop variables shall not exceed the number of dimensions of the array variable. The scope of each loop variable is the **foreach** constraint construct, including its *constraint set*. The type of each loop variable is implicitly declared to be consistent with the type of array index. An empty loop variable indicates no iteration over that dimension of the array. As with default arguments, a list of commas at the end can be omitted; thus, **foreach**(arr [j]) is a shorthand for **foreach**(arr [j, , , ,]). It shall be an error for any loop variable to have the same identifier as the array.

The mapping of loop variables to array indices is determined by the dimension cardinality, as described in [20.7](#).

```
//      1 2 3           3 4       1 2       -> Dimension numbers
int A [2][3][4];   bit [3:0][2:1] B [5:1][4];

foreach( A [ i, j, k ] ) ...
foreach( B [ q, r, , s ] ) ...
```

The first **foreach** causes i to iterate from 0 to 1, j from 0 to 2, and k from 0 to 3. The second **foreach** causes q to iterate from 5 to 1, r from 0 to 3, and s from 2 to 1.

foreach iterative constraints can include predicates. For example:

```
class C;
  rand int A[] ;

  constraint c1 { A.size inside {[1:10]}; }
  constraint c2 { foreach ( A[ k ] ) (k < A.size - 1) -> A[k + 1] > A[k]; }
endclass
```

The first constraint, c1, constrains the size of the array A to be between 1 and 10. The second constraint, c2, constrains each array value to be greater than the preceding one, i.e., an array sorted in ascending order.

Within a **foreach**, predicate expressions involving only constants, state variables, object handle comparisons, loop variables, or the size of the array being iterated behave as guards against the creation of constraints, and not as logical relations. For example, the implication in constraint *c2* above involves only a loop variable and the size of the array being iterated; thus, it allows the creation of a constraint only when $k < A.size() - 1$, which in this case prevents an out-of-bounds access in the constraint. Guards are described in more detail in [18.5.12](#).

Index expressions can include loop variables, constants, and state variables. Invalid or out of bound array indices are not automatically eliminated; users must explicitly exclude these indices using predicates.

The size method of a dynamic array or queue can be used to constrain the size of the array (see constraint *c1* above). If an array is constrained by both size constraints and iterative constraints, the size constraints are solved first, and the iterative constraints next. As a result of this implicit ordering between size constraints and iterative constraints, the size method shall be treated as a state variable within the **foreach** block of the corresponding array. For example, the expression *A.size* is treated as a random variable in constraint *c1* and as a state variable in constraint *c2*. This implicit ordering can cause the solver to fail in some situations.

18.5.7.2 Array reduction iterative constraints

The array reduction methods can produce a single integral value from an unpacked array of integral values (See [7.12.3](#)). In the context of a constraint, an array reduction method is treated as an expression iterated over each element of the array, joined by the relevant operand for each method. The result returns a single value of the same type as the array element type or, if specified, the type of the expression in the **with** clause. For example:

```
class C;
  rand bit [7:0] A[] ;
  constraint c1 { A.size == 5 }
  constraint c2 { A.sum() with {int'(item)} < 1000; }
endclass
```

The constraint *c2* will be interpreted as

```
( int'(A[0])+int'(A[1])+int'(A[2])+int'(A[3])+int'(A[4]) ) < 1000
```

18.5.8 Global constraints

When an object member of a class is declared **rand**, all of its constraints and random variables are randomized simultaneously along with the other class variables and constraints. Constraint expressions involving random variables from other objects are called *global constraints* (see [Figure 18-2](#)).

```
class A; // leaf node
  rand bit [7:0] v;
endclass

class B extends A; // heap node
  rand A left;
  rand A right;

  constraint heapcond {left.v <= v; right.v <= v;}
endclass
```

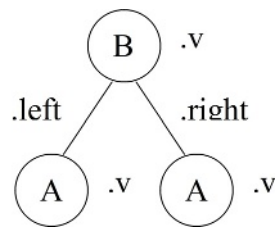

Figure 18-2—Global constraints

This example uses global constraints to define the legal values of an ordered binary tree. Class A represents a leaf node with an 8-bit value v . Class B extends class A and represents a heap node with value v , a left subtree, and a right subtree. Both subtrees are declared as **rand** in order to randomize them at the same time as other class variables. The constraint block named `heapcond` has two global constraints relating the left and right subtree values to the heap node value. When an instance of class B is randomized, the solver simultaneously solves for B and its left and right children, which in turn can be leaf nodes or more heap nodes.

The following rules determine which objects, variables, and constraints are to be randomized:

- a) First, determine the set of objects that are to be randomized as a whole. Starting with the object that invoked the `randomize()` method, add all objects that are contained within it, are declared **rand**, and are active (see `rand_mode` in 18.8). The definition is recursive and includes all of the active random objects that can be reached from the starting object. The objects selected in this step are referred to as the *active random objects*.
- b) Second, select all of the active constraints from the set of active random objects. These are the constraints that are applied to the problem.
- c) Third, select all of the active random variables from the set of active random objects. These are the variables that are to be randomized. All other variable references are treated as state variables, whose current value is used as a constant.

18.5.9 Variable ordering

The solver shall assure that the random values are selected to give a uniform value distribution over legal value combinations (that is, all combinations of legal values have the same probability of being the solution). This important property guarantees that all legal value combinations are equally probable, which allows randomization to better explore the whole design space.

Sometimes, however, it is desirable to force certain combinations to occur more frequently. Consider the case where a 1-bit control variable s constrains a 32-bit data value d :

```
class B;
  rand bit s;
  rand bit [31:0] d;

  constraint c { s -> d == 0; }
endclass
```

The constraint `c` says “ s implies d equals zero.” Although this reads as if s determines d , in fact s and d are determined together. There are 2^{33} possible combinations of $\{s, d\}$, but s is only true for $\{1, 0\}$. Thus, the probability that s is true is $1/2^{33}$, which is practically zero.

The constraints provide a mechanism for ordering variables so that *s* can be chosen independently of *d*. This mechanism defines a partial ordering on the evaluation of variables and is specified using the **solve** keyword.

```
class B;
  rand bit s;
  rand bit [31:0] d;
  constraint c { s -> d == 0; }
  constraint order { solve s before d; }
endclass
```

In this case, the order constraint instructs the solver to solve for *s* before solving for *d*. The effect is that *s* is now chosen true with 50% probability, and then *d* is chosen subject to the value of *s*. Accordingly, *d* == 0 shall occur 50% of the time, and *d* != 0 shall occur for the other 50%.

Variable ordering can be used to force selected corner cases to occur more frequently than they would otherwise. However, a “**solve...before...**” constraint does not change the solution space and, therefore, cannot cause the solver to fail.

The syntax to define variable order in a constraint block is as follows in [Syntax 18-7](#).

```
constraint_block_item ::= // from A.1.10
  solve solve_before_list before solve_before_list ;
  | constraint_expression
solve_before_list ::= solve_before_primary { , solve_before_primary }
solve_before_primary ::= [ implicit_class_handle . | class_scope ] hierarchical_identifier select
```

Syntax 18-7—Solve...before constraint ordering syntax (excerpt from [Annex A](#))

The following restrictions apply to variable ordering:

- Only random variables are allowed, that is, they shall be **rand**.
- **randc** variables are not allowed. **randc** variables are always solved before any other.
- The variables shall be integral values.
- A constraint block can contain both regular value constraints and ordering constraints.
- There shall be no circular dependencies in the ordering, such as “solve a before b” combined with “solve b before a.”
- Variables that are not explicitly ordered shall be solved with the last set of ordered variables. These values are deferred until as late as possible to assure a good distribution of values.
- Variables that are partially ordered shall be solved with the latest set of ordered variables so that all ordering constraints are met. These values are deferred until as late as possible to assure a good distribution of values.
- Variables can be solved in an order that is not consistent with the ordering constraints, provided that the outcome is the same. An example situation where this might occur is as follows:

```
x == 0;
x < y;
solve y before x;
```

In this case, because *x* has only one possible assignment (0), *x* can be solved for before *y*. The constraint solver can use this flexibility to speed up the solving process.

18.5.10 Static constraint blocks

A constraint block can be defined as static by including the **static** keyword in its definition.

The syntax to declare a static constraint block is as follows in [Syntax 18-8](#).

```
constraint_declaration ::= // from A.1.10
    [ static ] constraint constraint_identifier constraint_block
```

Syntax 18-8—Static constraint syntax (excerpt from [Annex A](#))

If a constraint block is declared as **static**, then calls to `constraint_mode()` shall affect all instances of the specified constraint in all objects. Thus, if a static constraint is set to OFF, it is off for all instances of that particular class.

When a constraint is declared using a constraint prototype and an external constraint block, the **static** keyword shall be applied to both the constraint prototype and the external constraint block, or to neither. It shall be an error if one but not the other is qualified **static**. Similarly, a pure constraint may be qualified **static** but any overriding constraint must match the pure constraint's qualification or absence thereof.

18.5.11 Functions in constraints

Some properties are unwieldy or impossible to express in a single expression. For example, the natural way to compute the number of ones in a packed array uses a loop:

```
function int count_ones ( bit [9:0] w );
    for( count_ones = 0; w != 0; w = w >> 1 )
        count_ones += w & 1'b1;
endfunction
```

Such a function could be used to constrain other random variables to the number of 1 bits:

```
constraint C1 { length == count_ones( v ) ; }
```

Without the ability to call a function, this constraint requires the loop to be unrolled and expressed as a sum of the individual bits:

```
constraint C2
{
    length == ((v>>9)&1) + ((v>>8)&1) + ((v>>7)&1) + ((v>>6)&1) + ((v>>5)&1) +
              ((v>>4)&1) + ((v>>3)&1) + ((v>>2)&1) + ((v>>1)&1) + ((v>>0)&1);
}
```

Unlike the `count_ones` function, more complex properties, which require temporary state or unbounded loops, may be impossible to convert into a single expression. The ability to call functions, thus, enhances the expressive power of the constraint language and reduces the likelihood of errors. The two constraints, C1 and C2, from above are not completely equivalent; C2 is bidirectional (`length` can constrain `v` and vice versa), whereas C1 is not.

To handle these common cases, SystemVerilog allows constraint expressions to include function calls, but it imposes certain semantic restrictions:

- Functions that appear in constraint expressions cannot contain **output** or **ref** arguments (**const ref** is allowed).

- Functions that appear in constraint expressions should be automatic (or preserve no state information) and have no side effects.
- Functions that appear in constraints cannot modify the constraints, for example, calling `rand_mode` or `constraint_mode` methods.
- Functions shall be called before constraints are solved, and their return values shall be treated as state variables.
- Random variables used as function arguments shall establish an implicit variable ordering or priority. Constraints that include only variables with higher priority are solved before other, lower priority constraints. Random variables solved as part of a higher priority set of constraints become state variables to the remaining set of constraints. For example:

```
class B;
  rand int x, y;
  constraint C { x <= F(y); }
  constraint D { y inside { 2, 4, 8 } ; }
endclass
```

forces `y` to be solved before `x`. Thus, constraint `D` is solved separately before constraint `C`, which uses the values of `y` and `F(y)` as state variables. In SystemVerilog, the behavior for variable ordering implied by function arguments differs from the behavior for ordering specified using the “`solve...before...`” constraint; function argument variable ordering subdivides the solution space thereby changing it. Because constraints on higher priority variables are solved without considering lower priority constraints at all, this subdivision can cause the overall constraints to fail. Within each prioritized set of constraints, cyclical (`randc`) variables are solved first.

- Circular dependencies created by the implicit variable ordering shall result in an error.
- Function calls in active constraints are executed an unspecified number of times (at least once) in an unspecified order.

18.5.12 Constraint guards

Constraint guards are predicate expressions that function as guards against the creation of constraints, and not as logical relations to be satisfied by the solver. These predicate expressions are evaluated before the constraints are solved and are characterized by involving only the following items:

- Constants
- State variables
- Object handle comparisons (comparisons between two handles or a handle and the constant `null`)

In addition to the above, iterative constraints (see [18.5.7](#)) also consider loop variables and the size of the array being iterated as state variables.

Treating these predicate expressions as constraint guards prevents the solver from generating evaluation errors, thereby failing on some seemingly correct constraints. This enables users to write constraints that avoid errors due to nonexistent object handles or array indices out of bounds. For example, the sort constraint of the singly linked list, `SList`, shown below is intended to assign a random sequence of numbers that is sorted in ascending order. However, the constraint expression will fail on the last element when `next.n` results in an evaluation error due to a nonexistent handle.

```
class SList;
  rand int n;
  rand SList next;

  constraint sort { n < next.n; }
endclass
```

The error condition above can be avoided by writing a predicate expression to guard against that condition:

```
constraint sort { if( next != null ) n < next.n; }
```

In the sort constraint above, the **if** prevents the creation of a constraint when `next == null`, which in this case avoids accessing a nonexistent object. Both implication (`->`) and **if...else** can be used as guards.

Guard expressions can themselves include subexpressions that result in evaluation errors (e.g., null references), and they are also guarded from generating errors. This logical sifting is accomplished by evaluating predicate subexpressions using the following 4-state representation:

- 0 FALSE Subexpression evaluates to FALSE.
- 1 TRUE Subexpression evaluates to TRUE.
- E ERROR Subexpression causes an evaluation error.
- R RANDOM Expression includes random variables and cannot be evaluated.

Every subexpression within a predicate expression is evaluated to yield one of the above four values. The subexpressions are evaluated in an arbitrary order, and the result of that evaluation plus the logical operation define the outcome in the alternate 4-state representation. A conjunction (`&&`), disjunction (`||`), or negation (`!`) of subexpressions can include some (perhaps all) guard subexpressions. The following rules specify the resulting value for the guard:

- Conjunction (`&&`): If any one of the subexpressions evaluates to FALSE, then the guard evaluates to FALSE. If any one subexpression evaluates to ERROR, then the guard evaluates to ERROR. Otherwise, the guard evaluates to TRUE.
 - If the guard evaluates to FALSE, then the constraint is eliminated.
 - If the guard evaluates to TRUE, then a (possibly conditional) constraint is generated.
 - If the guard evaluates to ERROR, then an error is generated and randomize fails.
- Disjunction (`||`): If any one of the subexpressions evaluates to TRUE, then the guard evaluates to TRUE. If any one subexpression evaluates to ERROR, then the guard evaluates to ERROR. Otherwise, the guard evaluates to FALSE.
 - If the guard evaluates to FALSE, then a (possibly conditional) constraint is generated.
 - If the guard evaluates to TRUE, then an unconditional constraint is generated.
 - If the guard evaluates to ERROR, then an error is generated and randomize fails.
- Negation (`!`): If the subexpression evaluates to ERROR, then the guard evaluates to ERROR. Otherwise, if the subexpression evaluates to TRUE or FALSE, then the guard evaluates to FALSE or TRUE, respectively.

These rules are codified by the truth tables shown in [Figure 18-3](#).

&&	0	1	E	R
0	0	0	0	0
1	0	1	E	R
E	0	E	E	E
R	0	R	E	R

Conjunction

	0	1	E	R
0	0	1	E	R
1	1	1	1	1
E	E	1	E	E
R	R	1	E	R

Disjunction

!	
0	1
1	0
E	E
R	R

Negation

Figure 18-3—Truth tables for conjunction, disjunction, and negation rules

These rules are applied recursively until all subexpressions are evaluated. The final value of the evaluated predicate expression determines the outcome as follows:

- If the result is **TRUE**, then an unconditional constraint is generated.
- If the result is **FALSE**, then the constraint is eliminated and can generate no error.
- If the result is **ERROR**, then an unconditional error is generated and the constraint fails.
- If the final result of the evaluation is **RANDOM**, then a conditional constraint is generated.

When the final value is **RANDOM**, a traversal of the predicate expression tree is needed to collect all conditional guards that evaluate to **RANDOM**. When the final value is **ERROR**, a subsequent traversal of the expression tree is not required, allowing implementations to issue only one error.

Example 1:

```
class D;  
  int x;  
endclass  
  
class C;  
  rand int x, y;  
  D a, b;  
  constraint c1 { (x < y || a.x > b.x || a.x == 5 ) -> x+y == 10; }  
endclass
```

In Example 1, the predicate subexpressions are $(x < y)$, $(a.x > b.x)$, and $(a.x == 5)$, which are all connected by disjunction. Some possible cases are as follows:

- Case 1: a is non-**null**, b is **null**, a.x is 5.
Because $(a.x == 5)$ is true, the fact that b.x generates an error does not result in an error.
The unconditional constraint $(x+y == 10)$ is generated.
- Case 2: a is **null**.
This always results in error, irrespective of the other conditions.
- Case 3: a is non-**null**, b is non-**null**, a.x is 10, b.x is 20.
All the guard subexpressions evaluate to **FALSE**.
The conditional constraint $(x < y) \rightarrow (x+y == 10)$ is generated.

Example 2:

```
class D;  
  int x;  
endclass  
  
class C;  
  rand int x, y;  
  D a, b;  
  constraint c1 { (x < y && a.x > b.x && a.x == 5 ) -> x+y == 10; }  
endclass
```

In Example 2, the predicate subexpressions are $(x < y)$, $(a.x > b.x)$, and $(a.x == 5)$, which are all connected by conjunction. Some possible cases are as follows:

- Case 1: a is non-**null**, b is **null**, a.x is 6.
Because $(a.x == 5)$ is false, the fact that b.x generates an error does not result in an error.
The constraint is eliminated.
- Case 2: a is **null**

This always results in error, irrespective of the other conditions.

- Case 3: a is non-**null**, b is non-**null**, a.x is 5, b.x is 2.

All the guard subexpressions evaluate to **TRUE**, producing constraint $(x < y) \rightarrow (x + y == 10)$.

Example 3:

```
class D;
  int x;
endclass

class C;
  rand int x, y;
  D a, b;
  constraint c1 { (x < y && (a.x > b.x || a.x == 5)) -> x + y == 10; }
endclass
```

In Example 3, the predicate subexpressions are $(x < y)$ and $(a.x > b.x || a.x == 5)$, which are connected by disjunction. Some possible cases are as follows:

- Case 1: a is non-**null**, b is **null**, a.x is 5.
The guard expression evaluates to $(\text{ERROR} || a.x == 5)$, which evaluates to $(\text{ERROR} || \text{TRUE})$
The guard subexpression evaluates to **TRUE**.
The conditional constraint $(x < y) \rightarrow (x + y == 10)$ is generated.
- Case 2: a is non-**null**, b is **null**, a.x is 8.
The guard expression evaluates to $(\text{ERROR} || \text{FALSE})$ and generates an error.
- Case 3: a is **null**
This always results in error, irrespective of the other conditions.
- Case 4: a is non-**null**, b is non-**null**, a.x is 5, b.x is 2.
All the guard subexpressions evaluate to **TRUE**.
The conditional constraint $(x < y) \rightarrow (x + y == 10)$ is generated.

18.6 Randomization methods

18.6.1 Randomize()

Variables in an object are randomized using the `randomize()` class method. Every class has a built-in `randomize()` virtual method, declared as follows:

```
virtual function int randomize();
```

The `randomize()` method is a virtual function that generates random values for all the active random variables in the object, subject to the active constraints.

The `randomize()` method returns 1 if it successfully sets all the random variables and objects to valid values; otherwise, it returns 0.

Example:

```
class SimpleSum;
  rand bit [7:0] x, y, z;
  constraint c { z == x + y; }
endclass
```

This class definition declares three random variables, *x*, *y*, and *z*. Calling the `randomize()` method shall randomize an instance of class `SimpleSum`:

```
SimpleSum p = new;  
int success = p.randomize();  
if (success == 1) ...
```

Checking the return status can be necessary because the actual value of state variables or addition of constraints in derived classes can render seemingly simple constraints unsatisfiable.

18.6.2 Pre_randomize() and post_randomize()

Every class contains `pre_randomize()` and `post_randomize()` methods, which are automatically called by `randomize()` before and after computing new random values.

The prototype for the `pre_randomize()` method is as follows:

```
function void pre_randomize();
```

The prototype for the `post_randomize()` method is as follows:

```
function void post_randomize();
```

When `obj.randomize()` is invoked, it first invokes `pre_randomize()` on `obj` and also all of its random object members that are enabled. After the new random values are computed and assigned, `randomize()` invokes `post_randomize()` on `obj` and also all of its random object members that are enabled.

Users can override the `pre_randomize()` in any class to perform initialization and set preconditions before the object is randomized. If the class is a derived class and no user-defined implementation of `pre_randomize()` exists, then `pre_randomize()` will automatically invoke `super.pre_randomize()`.

Users can override the `post_randomize()` in any class to perform cleanup, print diagnostics, and check post-conditions after the object is randomized. If the class is a derived class and no user-defined implementation of `post_randomize()` exists, then `post_randomize()` will automatically invoke `super.post_randomize()`.

If these methods are overridden, they shall call their associated base class methods; otherwise, their pre- and post-randomization processing steps shall be skipped.

The `pre_randomize()` and `post_randomize()` methods are not virtual. However, because they are automatically called by the `randomize()` method, which is virtual, they appear to behave as virtual methods.

18.6.3 Behavior of randomization methods

- Random variables declared as static are shared by all instances of the class in which they are declared. Each time the `randomize()` method is called, the variable is changed in every class instance.
- If `randomize()` fails, the constraints are infeasible, and the random variables retain their previous values.
- If `randomize()` fails, `post_randomize()` is not called.
- The `randomize()` method is built-in and cannot be overridden.

- The `randomize()` method implements object random stability. An object can be seeded by calling its `srandom()` method (see [18.13.3](#)).
- The built-in methods `pre_randomize()` and `post_randomize()` are functions and cannot block.

18.7 In-line constraints—`randomize()` with

By using the `randomize()` **with** construct, users can declare in-line constraints at the point where the `randomize()` method is called. These additional constraints are applied along with the object constraints.

The syntax for `randomize()` **with** is as follows in [Syntax 18-9](#).

```

inline_constraint_declaration ::=                                     // not in Annex A
  class_variable_identifier . randomize [ ( [ variable_identifier_list | null ] ) ]
    with [ ( [ identifier_list ] ) ] constraint_block
randomize_call ::=                                               // from A.1.10
  randomize { attribute_instance }
    [ ( [ variable_identifier_list | null ] ) ]
    [ with [ ( [ identifier_list ] ) ] constraint_block ]34

```

³⁴) In a `randomize_call` that is not a method call of an object of class type (i.e. a scope `randomize`), the optional parenthesized *identifier_list* after the keyword **with** shall be illegal, and the use of **null** shall be illegal.

Syntax 18-9—In-line constraint syntax (excerpt from [Annex A](#))

The *class_variable_identifier* is the name of an instantiated object.

The unnamed *constraint_block* contains additional in-line constraints to be applied along with the object constraints declared in the class.

For example:

```

class SimpleSum;
  rand bit [7:0] x, y, z;
  constraint c {z == x + y;}
endclass

task InlineConstraintDemo(SimpleSum p);
  int success;
  success = p.randomize() with {x < y;};
endtask

```

This is the same example used before; however, `randomize()` **with** is used to introduce an additional constraint that `x < y`.

The `randomize()` **with** construct can be used anywhere an expression can appear. The constraint block following **with** can define all of the same constraint types and forms as would otherwise be declared in a class.

The `randomize()` **with** constraint block can also reference local variables and subroutine arguments, eliminating the need for mirroring a local state as member variables in the object class. When the constraint block is not preceded by the optional parenthesized *identifier_list*, the constraint block is considered to be *unrestricted*. The scope for resolution of variable names referenced in an unrestricted constraint block

begins with the `randomize()` **with** object class; that is, the class of the object handle used in the method call to `randomize`. Then, if a name fails to resolve within the `randomize()` **with** object class, the name is resolved normally starting in the scope containing the inline constraint. Names qualified by **this** or **super** shall bind to the class of the object handle used in the call to the `randomize()` **with** method. Hence, it shall be an error if the qualified name fails to resolve within the `randomize()` **with** object class.

The `local::` qualifier (see [18.7.1](#)) is used to bypass the scope of the (`randomize()` **with** object) class and begin the name resolution procedure in the (local) scope that contains the `randomize` method call.

When the *constraint_block* is preceded by the optional parenthesized *identifier_list*, the constraint block is considered to be *restricted*. In a restricted constraint block, only variables whose name resolution begins with identifiers in the *identifier_list* shall resolve into the `randomize()` **with** object class; all other names shall resolve starting in the scope containing the `randomize` method call. When the parenthesized *identifier_list* is present and the `local::` qualifier is used, the qualified name shall resolve starting in the scope containing the `randomize` method call independent of whether the name is present in the *identifier_list*.

In the example below, the `randomize()` **with** class is C1.

```
class C1;
  rand integer x;
endclass

class C2;
  integer x;
  integer y;

  task doit(C1 f, integer x, integer z);
    int result;
    result = f.randomize() with {x < y + z};
  endtask
endclass
```

In the `f.randomize()` **with** constraint block, `x` is a member of class C1 and hides the `x` in class C2. It also hides the `x` argument in the `doit()` task. `y` is a member of C2. `z` is a local argument.

A restricted constraint block can be used to guarantee that local variable references will resolve into a local scope.

```
class C;
  rand integer x;
endclass

function int F(C obj, integer y);
  F = obj.randomize() with (x) { x < y; };
endfunction
```

In this example, only `x` is resolved into the object `obj` since only `x` is listed in the *identifier_list*. The reference to `y` will never bind into `obj` even if a later change adds a property named `y` into class C.

18.7.1 local:: Scope resolution

The `randomize()` **with** constraint block can reference both class properties and variables local to the method call. Unqualified names in an unrestricted in-lined constraint block are then resolved by searching first in the scope of the `randomize()` **with** object class followed by a search of the scope containing the method call—the local scope. The `local::` qualifier modifies the resolution search order. When applied to

an identifier within an in-line constraint, the `local::` qualifier bypasses the scope of the `[randomize() with object]` class and resolves the identifier in the local scope.

In the example below, the `randomize() with` class is `C`, and the local scope is the function `F()`:

```
class C;
  rand integer x;
endclass

function int F(C obj, integer x);
  F = obj.randomize() with { x < local::x; };
endfunction
```

In the unrestricted in-line constraint block of the `obj.randomize()` call, the unqualified name, `x`, binds to the property of class `C` (the scope of the object being randomized) while the qualified name `local::x` binds to the argument of the function `F()` (the local scope).

As a result of the above rules, the following apply:

- Names qualified only by `this` or `super` shall bind to the class of the object handle used in the `randomize() with` method call.
- Names qualified by `local::` shall bind to the scope containing the `randomize` method call, including the special names `this` or `super` (i.e., `local::this`).
- The `local::` prefix may be used to qualify class scopes and type names.
- As it pertains to wildcard package imports, the syntactic form `local::a` shall be semantically identical to the unqualified name `a` declared in the local scope.
- Given a method call `obj.randomize() with`, the name `local::obj` shall bind to the scope of the `randomize() with` object class.

18.8 Disabling random variables with `rand_mode()`

The `rand_mode()` method can be used to control whether a random variable is active or inactive. When a random variable is inactive, it is treated the same as if it had not been declared `rand` or `randc`. Inactive variables are not randomized by the `randomize()` method, and their values are treated as state variables by the solver. All random variables are initially active.

The syntax for the `rand_mode()` method is as follows:

```
task object[.random_variable]::rand_mode( bit on_off );
```

or

```
function int object.random_variable::rand_mode();
```

The *object* is any expression that yields the object handle in which the random variable is defined.

The *random_variable* is the name of the random variable to which the operation is applied. If it is not specified (only allowed when called as a task), the action is applied to all random variables within the specified object.

When called as a task, the argument to the `rand_mode` method determines the operation to be performed as shown in [Table 18-1](#).

Table 18-1—`rand_mode` argument

Value	Meaning	Description
0	OFF	Sets the specified variables to inactive so that they are not randomized on subsequent calls to the <code>randomize()</code> method.
1	ON	Sets the specified variables to active so that they are randomized on subsequent calls to the <code>randomize()</code> method.

For unpacked array variables, `random_variable` can specify individual elements using the corresponding index. Omitting the index results in all the elements of the array being affected by the call.

For unpacked structure variables, `random_variable` can specify individual members using the corresponding member. Omitting the member results in all the members of the structure being affected by the call.

If the random variable is an object handle, only the mode of the variable is changed, not the mode of random variables within that object (see global constraints in [18.5.8](#)).

A compiler error shall be issued if the specified variable does not exist within the class hierarchy or it exists but is not declared as `rand` or `randc`.

When called as a function, `rand_mode()` returns the current active state of the specified random variable. It returns 1 if the variable is active (ON) and 0 if the variable is inactive (OFF).

The function form of `rand_mode()` only accepts singular variables; thus, if the specified variable is an unpacked array, a single element shall be selected via its index.

Example:

```

class Packet;
    rand integer source_value, dest_value;
    ... other declarations
endclass

int ret;
Packet packet_a = new;
// Turn off all variables in object
packet_a.rand_mode(0);

// ... other code
// Enable source_value
packet_a.source_value.rand_mode(1);

ret = packet_a.dest_value.rand_mode();

```

This example first disables all random variables in the object `packet_a` and then enables only the `source_value` variable. Finally, it sets the `ret` variable to the active status of variable `dest_value`.

The `rand_mode()` method is built-in and cannot be overridden.

If a random variable is declared as **static**, the `rand_mode` state of the variable shall also be static. For example, if `rand_mode()` is set to `inactive`, the random variable is inactive in all instances of the base class.

18.9 Controlling constraints with `constraint_mode()`

The `constraint_mode()` method can be used to control whether a constraint is active or inactive. When a constraint is inactive, it is not considered by the `randomize()` method. All constraints are initially active.

The syntax for the `constraint_mode()` method is as follows:

```
task object[.constraint_identifier]::constraint_mode( bit on_off );
```

or

```
function int object.constraint_identifier::constraint_mode();
```

The *object* is any expression that yields the object handle in which the constraint is defined.

The *constraint identifier* is the name of the constraint block to which the operation is applied. The constraint name can be the name of any constraint block in the class hierarchy. If no constraint name is specified (only allowed when called as a task), the operation is applied to all constraints within the specified object.

When called as a task, the argument to the `constraint_mode` task method determines the operation to be performed as shown in [Table 18-2](#).

Table 18-2—constraint_mode argument

Value	Meaning	Description
0	OFF	Sets the specified constraint block to inactive so that it is not enforced by subsequent calls to the <code>randomize()</code> method.
1	ON	Sets the specified constraint block to active so that it is considered on subsequent calls to the <code>randomize()</code> method.

A compiler error shall be issued if the specified constraint block does not exist within the class hierarchy.

When called as a function, `constraint_mode()` returns the current active state of the specified constraint block. It returns 1 if the constraint is active (`ON`) and 0 if the constraint is inactive (`OFF`).

Example:

```
class Packet;
  rand integer source_value;
  constraint filter1 { source_value > 2 * m; }
endclass

function integer toggle_rand( Packet p );
  if ( p.filter1.constraint_mode() )
    p.filter1.constraint_mode(0);
  else
    p.filter1.constraint_mode(1);

  toggle_rand = p.randomize();
endfunction
```

In this example, the `toggle_rand` function first checks the current active state of the constraint `filter1` in the specified `Packet` object `p`. If the constraint is active, the function deactivates it; if it is inactive, the function activates it. Finally, the function calls the `randomize` method to generate a new random value for variable `source_value`.

The `constraint_mode()` method is built-in and cannot be overridden.

18.10 Dynamic constraint modification

There are several ways to dynamically modify randomization constraints, as follows:

- Implication and **if-else** style constraints allow declaration of predicated constraints.
- Constraint blocks can be made active or inactive using the `constraint_mode()` built-in method. Initially, all constraint blocks are active. Inactive constraints are ignored by the `randomize()` function.
- Random variables can be made active or inactive using the `rand_mode()` built-in method. Initially, all **rand** and **randc** variables are active. Inactive variables are not randomized by the `randomize()` method, and their values are treated as state variables by the solver.
- The weights in a **dist** constraint can be changed, affecting the probability that particular values in the set are chosen.

18.11 In-line random variable control

The `randomize()` method can be used to temporarily control the set of random and state variables within a class instance or object. When the `randomize` method is called with no arguments, it behaves as described in the previous subclauses, that is, it assigns new values to all random variables in an object—those declared as **rand** or **randc**—so that all of the constraints are satisfied. When `randomize` is called with arguments, those arguments designate the complete set of random variables within that object; all other variables in the object are considered state variables. For example, consider the following class and calls to `randomize`:

```
class CA;
    rand byte x, y;
    byte v, w;

    constraint c1 { x < v && y > w };
endclass

CA a = new;

a.randomize();           // random variables: x, y state variables: v, w
a.randomize( x );       // random variables: x state variables: y, v, w
a.randomize( v, w );    // random variables: v, w state variables: x, y
a.randomize( w, x );    // random variables: w, x state variables: y, v
```

This mechanism controls the set of active random variables for the duration of the call to `randomize`, which is conceptually equivalent to making a set of calls to the `rand_mode()` method to disable or enable the corresponding random variables. Calling `randomize()` with arguments allows changing the random mode of any class property, even those not declared as **rand** or **randc**. This mechanism, however, does not affect the cyclical random mode; it cannot change a nonrandom variable into a cyclical random variable (**randc**) and cannot change a cyclical random variable into a noncyclical random variable (change from **randc** to **rand**).

The scope of the arguments to the `randomize` method is the object class. Arguments are limited to the names of properties of the calling object; expressions are not allowed. The random mode of local class members

can only be changed when the call to `randomize` has access to those properties, that is, within the scope of the class in which the local members are declared.

18.11.1 In-line constraint checker

Normally, calling the `randomize` method of a class that has no random variables causes the method to behave as a checker. In other words, it assigns no random values and only returns a status: 1 if all constraints are satisfied and 0 otherwise. The in-line random variable control mechanism can also be used to force the `randomize()` method to behave as a checker.

The `randomize` method accepts the special argument `null` to indicate no random variables for the duration of the call. In other words, all class members behave as state variables. This causes the `randomize` method to behave as a checker instead of a generator. A checker evaluates all constraints and simply returns 1 if all constraints are satisfied and 0 otherwise. For example, if class `CA` defined previously executes the following call:

```
success = a.randomize( null ); // no random variables
```

then the solver considers all variables as state variables and only checks whether the constraint is satisfied, namely, that the relation $(x < v \ \&\& \ y > w)$ is true using the current values of `x`, `y`, `v`, and `w`.

18.12 Randomization of scope variables—`std::randomize()`

The built-in class `randomize` method operates exclusively on class member variables. Using classes to model the data to be randomized is a powerful mechanism that enables the creation of generic, reusable objects containing random variables and constraints that can be later extended, inherited, constrained, overridden, enabled, disabled, and merged with or separated from other objects. The ease with which classes and their associated random variables and constraints can be manipulated makes classes an ideal vehicle for describing and manipulating random data and constraints. However, some less-demanding problems that do not require the full flexibility of classes can use a simpler mechanism to randomize data that do not belong to a class. The scope `randomize` function, `std::randomize()`, enables users to randomize data in the current scope without the need to define a class or instantiate a class object.

The syntax of the scope `randomize` function is as follows in [Syntax 18-10](#).

```
scope_randomize ::=
  [ std:: ] randomize ( [ variable_identifier_list ] ) [ with constraint_block ]
```

Syntax 18-10—Scope randomize function syntax (not in [Annex A](#))

The scope `randomize` function behaves exactly the same as a class `randomize` method, except that it operates on the variables of the current scope instead of class member variables. Arguments to this function specify the variables that are to be assigned random values, i.e., the random variables.

For example:

```
module stim;
  bit [15:0] addr;
  bit [31:0] data;

  function bit gen_stim();
    bit success, rd_wr;
```



```

    success = randomize( addr, data, rd_wr ); // call std::randomize
    return rd_wr ;
endfunction

...
endmodule

```

The function `gen_stim` calls `std::randomize()` with three variables as arguments: `addr`, `data`, and `rd_wr`. Thus, `std::randomize()` assigns new random variables to the variables that are visible in the scope of the `gen_stim` function. In the preceding example, `addr` and `data` have module scope, whereas `rd_wr` has scope local to the function. The preceding example can also be written using a class:

```

class stimc;
    rand bit [15:0] addr;
    rand bit [31:0] data;
    rand bit rd_wr;
endclass

function bit gen_stim( stimc p );
    bit [15:0] addr;
    bit [31:0] data;
    bit success;
    success = p.randomize();
    addr = p.addr;
    data = p.data;
    return p.rd_wr;
endfunction

```

However, for this simple application, the scope `randomize` function leads to a straightforward implementation.

The scope `randomize` function returns 1 if it successfully sets all the random variables to valid values; otherwise, it returns 0. If the scope `randomize` function is called with no argument, it shall not change the value of any variable but instead it shall check its constraints. All constraint expressions in its `constraint_block` shall be evaluated, and if one or more of those expressions evaluates to false (0) then the `randomize` call shall return 0; otherwise it shall return 1.

18.12.1 Adding constraints to scope variables—`std::randomize()` with

The `std::randomize()` **with** form of the scope `randomize` function allows users to specify random constraints to be applied to the local scope variables. When specifying constraints, the arguments to the scope `randomize` function become random variables; all other variables are considered state variables.

```

task stimulus( int length );
    int a, b, c, success;

    success = std::randomize( a, b, c ) with { a < b ; a + b < length ; };
    ...
    success = std::randomize( a, b ) with { b - a > length ; };
    ...
endtask

```

The task `stimulus` above calls `std::randomize` twice resulting in two sets of random values for its local variables `a`, `b`, and `c`. In the first call, variables `a` and `b` are constrained so that variable `a` is less than `b` and their sum is less than the task argument `length`, which is designated as a state variable. In the second call, variables `a` and `b` are constrained so that their difference is greater than the state variable `length`.

18.13 Random number system functions and methods

18.13.1 \$urandom

The system function `$urandom` provides a mechanism for generating pseudo-random numbers. The function returns a new 32-bit random number each time it is called. The number shall be unsigned.

The syntax for `$urandom` is as follows:

```
function int unsigned $urandom[ (int seed ) ] ;
```

The `seed` is an optional argument that determines the sequence of random numbers generated. The seed can be any integral expression. The random number generator (RNG) shall generate the same sequence of random numbers every time the same seed is used.

The RNG is deterministic. Each time the program executes, it cycles through the same random sequence. This sequence can be made nondeterministic by seeding the `$urandom` function with an extrinsic random variable, such as the time of day.

For example:

```
bit [64:1] addr;
bit [ 3:0] number;

addr[32:1] = $urandom( 254 ); // Initialize the generator,
                             // get 32-bit random number
addr = { $urandom, $urandom }; // 64-bit random number
number = $urandom & 15;      // 4-bit random number
```

18.13.2 \$urandom_range()

The `$urandom_range()` function returns an unsigned integer within a specified range.

The syntax for `$urandom_range()` is as follows:

```
function int unsigned $urandom_range( int unsigned maxval,
                                       int unsigned minval = 0 );
```

The function shall return an unsigned integer in the range of `maxval ... minval`.

Example:

```
val = $urandom_range(7,0);
```

If `minval` is omitted, the function shall return a value in the range of `maxval ... 0`.

Example:

```
val = $urandom_range(7);
```

If `maxval` is less than `minval`, the arguments are automatically reversed so that the first argument is larger than the second argument.

Example:

```
val = $urandom_range(0,7);
```

All of the three previous examples produce a value in the range of 0 to 7, inclusive.

`$urandom_range()` is automatically thread stable (see [18.14.2](#)).

18.13.3 `srandom()`

The `srandom()` method allows manually seeding the RNG of objects or threads. The RNG of a process can be seeded using the `srandom()` method of the process (see [9.7](#)).

The prototype of the `srandom()` method is as follows:

```
function void srandom( int seed );
```

The `srandom()` method initializes an object's RNG using the value of the given seed.

18.13.4 `get_randstate()`

The `get_randstate()` method retrieves the current state of an object's RNG. The state of the RNG associated with a process is retrieved using the `get_randstate()` method of the process (see [9.7](#)).

The prototype of the `get_randstate()` method is as follows:

```
function string get_randstate();
```

The `get_randstate()` method returns a copy of the internal state of the RNG associated with the given object.

The RNG state is a string of unspecified length and format. The length and contents of the string are implementation dependent.

18.13.5 `set_randstate()`

The `set_randstate()` method sets the state of an object's RNG. The state of the RNG associated with a process is set using the `set_randstate()` method of the process (see [9.7](#)).

The prototype of the `set_randstate()` method is as follows:

```
function void set_randstate( string state );
```

The `set_randstate()` method copies the given state into the internal state of an object's RNG.

The RNG state is a string of unspecified length and format. Calling `set_randstate()` with a string value that was not obtained from `get_randstate()`, or from a different implementation of `get_randstate()`, is undefined.

18.14 Random stability

The RNG is localized to threads and objects. Because the sequence of random values returned by a thread or object is independent of the RNG in other threads or objects, this property is called *random stability*. Random stability applies to the following:

- The system randomization calls, `$urandom()` and `$urandom_range()`
- The object and process random seeding method, `srandom()`
- The object randomization method, `randomize()`

Testbenches with this feature exhibit more stable RNG behavior in the face of small changes to the user code. Additionally, it enables more precise control over the generation of random values by manually seeding threads and objects.

18.14.1 Random stability properties

Random stability encompasses the following properties:

- *Initialization RNG.* Each module instance, interface instance, program instance, and package has an initialization RNG. Each initialization RNG is seeded with the default seed. The default seed is an implementation-dependent value. An initialization RNG shall be used in the creation of static processes and static initializers (see the following bullets). Static processes are defined in [Annex P](#).
- *Thread stability.* Each thread has an independent RNG for all randomization system calls invoked from that thread. When a new dynamic thread is created, its RNG is seeded with the next random value from its parent thread. This property is called *hierarchical seeding*. When a static process is created, its RNG is seeded with the next value from the initialization RNG of the module instance, interface instance, program instance, or package containing the thread declaration.

Program and thread stability can be achieved as long as thread creation and random number generation are done in the same order as before. When adding new threads to an existing test, they can be added at the end of a code block in order to maintain random number stability of previously created work.

- *Object stability.* Each class instance (object) has an independent RNG for all randomization methods in the class. When an object is created using `new`, its RNG is seeded with the next random value from the thread that creates the object. When a class object is created by a static declaration initializer, there is no active thread; thus, the RNG of the created object is seeded with the next random value of the initialization RNG of the module instance, interface instance, program instance, or package in which the declaration occurred.

Object stability shall be preserved when object and thread creation and random number generation are done in the same order as before. In order to maintain random number stability, new objects, threads, and random numbers can be created after existing objects are created.

- *Manual seeding.* All noninitialization RNGs can be manually seeded. Combined with hierarchical seeding, this facility allows users to define the operation of a subsystem (hierarchy subtree) completely with a single seed at the root thread of the subsystem.

18.14.2 Thread stability

Random values returned from the `$urandom` system call are independent of thread execution order. For example:

```
integer x, y, z;
fork      //set a seed at the start of a thread
  begin process::self.srandom(100); x = $urandom; end
        //set a seed during a thread
  begin y = $urandom; process::self.srandom(200); end
        // draw 2 values from the thread RNG
  begin z = $urandom + $urandom ; end
join
```

The above program fragment illustrates the following several properties:

- *Thread locality.* The values returned for x , y , and z are independent of the order of thread execution. This is an important property because it allows development of subsystems that are independent, controllable, and predictable.
- *Hierarchical seeding.* When a thread is created, its random state is initialized using the next random value from the parent thread as a seed. The three forked threads are all seeded from the parent thread.

Each thread is seeded with a unique value, determined solely by its parent. The root of a thread execution subtree determines the random seeding of its children. This allows entire subtrees to be moved and preserves their behavior by manually seeding their root thread.

18.14.3 Object stability

The `randomize()` method built into every class exhibits object stability. This is the property that calls to `randomize()` in one instance are independent of calls to `randomize()` in other instances and are independent of calls to other randomize functions.

For example:

```
class C1;
    rand integer x;
endclass

class C2;
    rand integer y;
endclass

initial begin
    C1 c1 = new();
    C2 c2 = new();
    integer z;
    void' (c1.randomize());
    // z = $random;
    void' (c2.randomize());
end
```

- The values returned for `c1.x` and `c2.y` are independent of each other.
- The calls to `randomize()` are independent of the `$random` system call. If one uncomments the line `z = $random` above, there is no change in the values assigned to `c1.x` and `c2.y`.
- Each instance has a unique source of random values that can be seeded independently. That random seed is taken from the parent thread when the instance is created.
- Objects can be seeded at any time using the `srandom()` method.

```
class C3
    function new (integer seed);
        //set a new seed for this instance
        this.srandom(seed);
    endfunction
endclass
```

Once an object is created, there is no guarantee that the creating thread can change the object's random state before another thread accesses the object. Therefore, it is best that objects self-seed within their `new` method rather than externally.

An object's seed can be set from any thread. However, a thread's seed can only be set from within the thread itself.

18.15 Manually seeding randomize

Each object maintains its own internal RNG, which is used exclusively by its `randomize()` method. This allows objects to be randomized independently of each other and of calls to other system randomization functions. When an object is created, its RNG is seeded using the next value from the RNG of the thread that creates the object. This process is called *hierarchical object seeding*.

Sometimes it is desirable to manually seed an object's RNG using the `srandom()` method. This can be done either in a class method or external to the class definition:

An example of seeding the RNG internally, as a class method, is as follows:

```
class Packet;
  rand bit[15:0] header;
  ...
  function new (int seed);
    this.srandom(seed);
    ...
  endfunction
endclass
```

An example of seeding the RNG externally is as follows:

```
Packet p = new(200); // Create p with seed 200.
p.srandom(300);     // Re-seed p with seed 300.
```

Calling `srandom()` in an object's `new()` function assures the object's RNG is set with the new seed before any class member values are randomized.

18.16 Random weighted case—randcase

```
statement_item ::= //from A.6.4
  ...
  | randcase_statement
randcase_statement ::= //from A.6.7
  randcase randcase_item { randcase_item } endcase
randcase_item ::= expression : statement_or_null
```

Syntax 18-11—Randcase syntax (excerpt from [Annex A](#))

The keyword `randcase` introduces a `case` statement that randomly selects one of its branches. The *randcase_item expressions* are non-negative integral values that constitute the branch weights. An item's weight divided by the sum of all weights gives the probability of taking that branch. For example:

```
randcase
  3 : x = 1;
  1 : x = 2;
  4 : x = 3;
endcase
```

The sum of all weights is 8; therefore, the probability of taking the first branch is 0.375, the probability of taking the second is 0.125, and the probability of taking the third is 0.5.

If a branch specifies a zero weight, then that branch is not taken. If all *randcase_items* specify zero weights, then no branch is taken and a warning can be issued.

The randcase weights can be arbitrary expressions, not just constants. For example:

```
byte a, b;

randcase
  a + b : x = 1;
  a - b : x = 2;
  a ^ ~b : x = 3;
  12'b800 : x = 4;
endcase
```

The precision of each weight expression is self-determined. The sum of the weights is computed using standard addition semantics (maximum precision of all weights), where each summand is unsigned. Each weight expression is evaluated at most once (implementations can cache identical expressions) in an unspecified order. In the example above, the first three weight expressions are computed using 8-bit precision, and the fourth expression is computed using 12-bit precision. The resulting weights are added as unsigned values using 12-bit precision. The weight selection then uses unsigned 12-bit comparison.

Each call to **randcase** retrieves one random number in the range of 0 to the sum of the weights. The weights are then selected in declaration order: smaller random numbers correspond to the first (top) weight statements.

Randcase statements exhibit thread stability. The random numbers are obtained from `$urandom_range()`; thus, random values drawn are independent of thread execution order. This can result in multiple calls to `$urandom_range()` to handle greater than 32 bits.

18.17 Random sequence generation—randsequence

Parser generators, such as yacc, use a BNF or similar notation to describe the grammar of the language to be parsed. The grammar is thus used to generate a program that is able to check whether a stream of tokens represents a syntactically correct utterance in that language. SystemVerilog's sequence generator reverses this process. It uses the grammar to randomly create a correct utterance (i.e., a stream of tokens) of the language described by the grammar. The random sequence generator is useful for randomly generating structured sequences of stimulus such as instructions or network traffic patterns.

The sequence generator uses a set of rules and productions within a **randsequence** block. The syntax of the **randsequence** block is as follows in [Syntax 18-12](#).

```
statement_item ::= // from A.6.4
  ...
  | randsequence_statement
randsequence_statement ::= randsequence ( [ production_identifier ] ) // from A.6.12
  production { production }
  endsequence
production ::= [ data_type_or_void ] production_identifier [ ( tf_port_list ) ] : rs_rule { | rs_rule } ;
rs_rule ::= rs_production_list [ := weight_specification [ rs_code_block ] ]
```

```

rs_production_list ::=
  rs_prod { rs_prod }
  | rand join [ ( expression ) ] production_item production_item { production_item }
weight_specification ::=
  integral_number
  | ps_identifier
  | ( expression )
rs_code_block ::= { { data_declaration } { statement_or_null } }
rs_prod ::=
  production_item
  | rs_code_block
  | rs_if_else
  | rs_repeat
  | rs_case
production_item ::= production_identifier [ ( list_of_arguments ) ]
rs_if_else ::= if ( expression ) production_item [ else production_item ]
rs_repeat ::= repeat ( expression ) production_item
rs_case ::= case ( case_expression ) rs_case_item { rs_case_item } endcase
rs_case_item ::=
  case_item_expression { , case_item_expression } : production_item ;
  | default [ : ] production_item ;
case_expression ::= expression
case_item_expression ::= expression

```

//from [A.6.7](#)

Syntax 18-12—Randsequence syntax (excerpt from [Annex A](#))

A **randsequence** grammar is composed of one or more productions. Each production contains a name and a list of production items. Production items are further classified into terminals and nonterminals. Nonterminals are defined in terms of terminals and other nonterminals. A terminal is an indivisible item that needs no further definition than its associated code block. Ultimately, every nonterminal is decomposed into its terminals. A production list contains a succession of production items, indicating that the items must be streamed in sequence. A single production can contain multiple production lists separated by the | symbol. Production lists separated by a | imply a set of choices, which the generator will make at random.

A simple example illustrates the basic concepts:

```

randsequence( main )
  main      : first second done ;
  first     : add | dec ;
  second    : pop | push ;
  done      : { $display("done"); } ;
  add       : { $display("add"); } ;
  dec       : { $display("dec"); } ;
  pop       : { $display("pop"); } ;
  push      : { $display("push"); } ;
endsequence

```

The production `main` is defined in terms of three nonterminals: `first`, `second`, and `done`. When `main` is chosen, it generates the sequence, `first`, `second`, and `done`. When the first production is generated, it is decomposed into its productions, which specify a random choice between `add` and `dec`. Similarly, the second production specifies a choice between `pop` and `push`. All other productions are terminals; they are

completely specified by their code block, which in the example displays the production name. Thus, the grammar leads to the following possible outcomes:

```
add pop done
add push done
dec pop done
dec push done
```

When the **randsequence** statement is executed, it generates a grammar-driven stream of random productions. As each production is generated, the side effects of executing its associated code blocks produce the desired stimulus. In addition to the basic grammar, the sequence generator provides for random weights, interleaving, and other control mechanisms. Although the **randsequence** statement does not intrinsically create a loop, a recursive production will cause looping.

The **randsequence** statement creates an automatic scope. All production identifiers are local to the scope. In addition, each code block within the **randsequence** block creates an anonymous automatic scope. Hierarchical references to the variables declared within the code blocks are not allowed. To declare a static variable, the **static** prefix shall be used. The **randsequence** keyword can be followed by an optional production name (inside the parentheses) that designates the name of the top-level production. If unspecified, the first production becomes the top-level production.

18.17.1 Random production weights

The probability that a production list is generated can be changed by assigning weights to production lists. The probability that a particular production list is generated is proportional to its specified weight.

```
production ::= // from A.6.12
  [ data_type_or_void ] production_identifier [ ( tf_port_list ) ] : rs_rule { | rs_rule } ;
rs_rule ::= rs_production_list [ := weight_specification [ rs_code_block ] ]
```

Syntax 18-13—Random production weights syntax (excerpt from [Annex A](#))

The **:=** operator assigns the weight specified by the *weight_specification* to its production list. A *weight_specification* shall evaluate to an integral non-negative value. A weight is only meaningful when assigned to alternative productions, that is, production list separated by a |. Weight expressions are evaluated when their enclosing production is selected, thus allowing weights to change dynamically. For example, the first production of the previous example can be rewritten as follows:

```
first : add := 3
      | dec := (1 + 1) // 2
      ;
```

This defines the production *first* in terms of two weighted production lists, *add* and *dec*. The production *add* will be generated with 60% probability, and the production *dec* will be generated with 40% probability.

If no weight is specified, a production shall use a weight of 1. If only some weights are specified, the unspecified weights shall use a weight of 1.

18.17.2 if-else production statements

A production can be made conditionally by means of an **if-else** production statement. The syntax of the **if-else** production statement is as follows in [Syntax 18-14](#).

```
rs_if_else ::= if ( expression ) production_item [ else production_item ] //from A.6.12
```

Syntax 18-14—If-else conditional random production syntax (excerpt from [Annex A](#))

The *expression* can be any expression that evaluates to a Boolean value. If the expression evaluates to true, the production following the expression is generated; otherwise, the production following the optional else statement is generated. For example:

```
randsequence ()
...
PP_PO : if ( depth < 2 ) PUSH else POP ;
PUSH  : { ++depth; do_push(); };
POP   : { --depth; do_pop(); };
endsequence
```

This example defines the production PP_OP. If the variable depth is less than 2, then production PUSH is generated. Otherwise, production POP is generated. The variable depth is updated by the code blocks of both the PUSH and POP productions.

18.17.3 Case production statements

A production can be selected from a set of alternatives using a **case** production statement. The syntax of the **case** production statement is as follows in [Syntax 18-15](#).

```
rs_case ::= case ( case_expression ) rs_case_item { rs_case_item } endcase //from A.6.12
rs_case_item ::=
  case_item_expression { , case_item_expression } : production_item ;
  | default [ : ] production_item ;
case_expression ::= expression //from A.6.7
case_item_expression ::= expression
```

Syntax 18-15—Case random production syntax (excerpt from [Annex A](#))

The case production statement is analogous to the procedural **case** statement except as noted below. The *case expression* is evaluated, and its value is compared against the value of each *case_item expression*, all of which are evaluated and compared in the order in which they are given. The production generated is the one associated with the first *case_item expression* matching the *case expression*. If no matching *case_item expression* is found, then the production associated with the optional default item is generated, or nothing if there is no default item. Multiple default statements in one case production statement shall be illegal. The *case_item expressions* separated by commas allow multiple expressions to share the production. For example:

```
randsequence ()
SELECT : case ( device & 7 )
  0      : NETWORK ;
  1, 2   : DISK ;
  default : MEMORY ;
endcase ;
...
endsequence
```

This example defines the production `SELECT` with a **case** statement. The *case_expression* (`device & 7`) is evaluated and compared against the two *case_item_expressions*. If the expression matches 0, the production `NETWORK` is generated; and if it matches 1 or 2, the production `DISK` is generated. Otherwise, the production `MEMORY` is generated.

18.17.4 Repeat production statements

The **repeat** production statement is used to iterate over a production a specified number of times. The syntax of the **repeat** production statement is as follows in [Syntax 18-16](#).

```
rs_repeat ::= repeat ( expression ) production_item // from A.6.12
```

Syntax 18-16—Repeat random production syntax (excerpt from [Annex A](#))

The **repeat** expression shall evaluate to a non-negative integral value. That value specifies the number of times that the corresponding production is generated. For example:

```
randsequence ( )
...
PUSH_OPER : repeat( $urandom_range( 2, 6 ) ) PUSH ;
PUSH      : ...
endsequence
```

In this example, the `PUSH_OPER` production specifies that the `PUSH` production be repeated a random number of times (between 2 and 6) depending on the value returned by `$urandom_range()`.

The **repeat** production statement itself cannot be terminated prematurely. A **break** statement will terminate the entire **randsequence** block (see [18.17.6](#)).

18.17.5 Interleaving productions—rand join

The **rand join** production control is used to randomly interleave two or more production sequences while maintaining the relative order of each sequence. The syntax of the **rand join** production control is as follows in [Syntax 18-17](#).

```
rs_production_list ::= // from A.6.12
  rs_prod { rs_prod }
  | rand join [ ( expression ) ] production_item production_item { production_item }
```

Syntax 18-17—Rand join random production syntax (excerpt from [Annex A](#))

For example:

```
randsequence ( TOP )
  TOP : rand join S1 S2 ;
  S1  : A B ;
  S2  : C D ;
endsequence
```

The generator will randomly produce the following sequences:

```
A B C D
```

```
A C B D
A C D B
C D A B
C A B D
C A D B
```

The optional expression following the **rand join** keywords shall be a real number in the range of 0.0 to 1.0. The value of this expression represents the degree to which the length of the sequences to be interleaved affects the probability of selecting a sequence. A sequence's length is the number of productions not yet interleaved at a given time. If the expression is 0.0, the shortest sequences are given higher priority. If the expression is 1.0, the longest sequences are given priority. For instance, using the previous example,

```
TOP : rand join (0.0) S1 S2 ;
```

gives higher priority to the sequences: A B C D C D A B, and

```
TOP : rand join (1.0) S1 S2 ;
```

gives higher priority to the sequences: A C B D A C D B C A B D C A D B.

If unspecified, the generator used the default value of 0.5, which does not prioritize any sequence length.

At each step, the generator interleaves nonterminal symbols to depth of 1.

18.17.6 Aborting productions—break and return

Two procedural statements can be used to terminate a production prematurely: **break** and **return**. These two statements can appear in any code block; they differ in what they consider the scope from which to exit.

The **break** statement terminates the sequence generation. When a **break** statement is executed from within a production code block, it forces a jump out of the **randsequence** block. For example:

```
randsequence ()
  WRITE   : SETUP DATA ;
  SETUP   : { if( fifo_length >= max_length ) break; } COMMAND ;
  DATA   : ...
endsequence
next_statement : ...
```

When the example above executes the **break** statement within the **SETUP** production, the **COMMAND** production is not generated, and execution continues on the line labeled `next_statement`. Use of the **break** statement within a loop statement behaves as defined in [12.8](#). Thus, the **break** statement terminates the smallest enclosing looping statement; otherwise, it terminates the **randsequence** block.

The **return** statement aborts the generation of the current production. When a **return** statement is executed from within a production code block, the current production is aborted. Sequence generation continues with the next production following the aborted production. For example:

```
randsequence ()
  TOP : P1 P2 ;
  P1  : A B C ;
  P2  : A { if( flag == 1 ) return; } B C ;
  A   : { $display( "A" ); } ;
  B   : { if( flag == 2 ) return; $display( "B" ); } ;
  C   : { $display( "C" ); } ;
endsequence
```

Depending on the value of variable `flag`, the example above displays the following:

```
flag == 0 ==> A B C A B C
flag == 1 ==> A B C A
flag == 2 ==> A C A C
```

When `flag == 1`, production P2 is aborted in the middle, after generating A. When `flag == 2`, production B is aborted twice (once as part of P1 and once as part of P2); however, each time, generation continues with the next production, C.

18.17.7 Value passing between productions

Data can be passed down to a production about to be generated, and generated productions can return data to the nonterminals that triggered their generation. Passing data to a production is similar to a task call and uses the same syntax. Returning data from a production requires that a type be declared for the production, which uses syntax similar to a function declaration.

Productions that accept data include a formal argument list. The syntax for declaring the arguments to a production is similar to a task prototype; the syntax for passing data to the production is the same as a task call (see [Syntax 18-18](#)).

```
production ::=
  [ data_type_or_void ] production_identifier [ ( tf_port_list ) ] : rs_rule { | rs_rule } ; //from A.6.12
```

Syntax 18-18—Random production syntax (excerpt from [Annex A](#))

For example, the first example above could be written as follows:

```
randsequence( main )
  main                : first second gen ;
  first               : add | dec ;
  second              : pop | push ;
  add                 : gen("add") ;
  dec                 : gen("dec") ;
  pop                 : gen("pop") ;
  push                : gen("push") ;
  gen( string s = "done" ) : { $display( s ); } ;
endsequence
```

In this example, the production `gen` accepts a string argument whose default is "done". Five other productions generate this production, each with a different argument (the one in `main` uses the default).

A production creates a scope, which encompasses all its rules and code blocks. Thus, arguments passed down to a production are available throughout the production.

Productions that return data require a type declaration. The optional return type precedes the production. Productions that do not specify a return type shall assume a void return type.

A value is returned from a production by using the `return` with an expression. When the `return` statement is used with a production that returns a value, it shall specify an expression of the correct type, just like non-void functions. The `return` statement assigns the given expression to the corresponding production. The return value can be read in the code blocks of the production that triggered the generation of the production returning a value. Within these code blocks, return values are accessed using the production name plus an optional indexing expression.

Within a rule, a variable is implicitly declared for each production (of the rule) that returns a value. The type of the variable is determined by the return type of the production and the number of times the production syntactically appears with the rule. If a production appears only once in a rule the type of the implicit variable is the return type of the production. If a production appears multiple times the type is an array where the element type is the return type of the production. The array is indexed from 1 to the number of times the production appears within the rule. The elements of the array are assigned the values returned by the instances of the production according to the syntactic order of appearance.

Example 1:

```

randsequence( bin_op )
  void bin_op      : value operator value // void type is optional
                    { $display("%s %b %b", operator, value[1], value[2]); }
                    ;
  bit [7:0] value : { return $urandom; } ;
  string operator :  add  := 5 { return "+" ; }
                    | dec  := 2 { return "-" ; }
                    | mult := 1 { return "*" ; }
                    ;
endsequence

```

In the example above, the `operator` and `value` productions return a string and an 8-bit value, respectively. The production `bin_op` includes these two value-returning productions. Therefore, the code block associated with production `bin_op` has access to the following implicit variable declarations:

```

bit [7:0] value [1:2];
string operator;

```

Example 2:

```

int cnt;
...
randsequence( A )
  void A      : A1 A2;
  void A1     : { cnt = 1; } B repeat(5) C B
                { $display("c=%d, b1=%d, b2=%d", C, B[1], B[2]); }
                ;
  void A2     : if (cond) D(5) else D(20)
                { $display("d1=%d, d2=%d", D[1], D[2]); }
                ;
  int B       : C { return C; }
                | C C { return C[2]; }
                | C C C { return C[3]; }
                ;
  int C       : { cnt = cnt + 1; return cnt; };
  int D (int prm) : { return prm; };
endsequence

```

In example 2, the code block in production A1 has access to the implicit variable declarations:

```

int B[1:2];
int C;

```

The code block in production A2 has access to the implicit variable declaration:

```

int D[1:2];

```

If `cond` is true, the first element is assigned the value returned by `D(5)`. If `cond` is false, the second element is assigned the value returned by `D(20)`.

The code block in the first rule of production `B` has access to the implicit variable declaration:

```
int C;
```

The code block in the third rule of production `B` has access to the implicit variable declaration:

```
int C[1:3];
```

Accessing these implicit variables yields the values returned from the corresponding productions. When executed, Example 1, above, displays a simple three-item random sequence: an operator followed by two 8-bit values. The operators `+`, `-`, and `*` are chosen with a distribution of 5/8, 2/8, and 1/8, respectively.

Only the return values of productions already generated (i.e., to the left of the code block accessing them) can be retrieved. Attempting to read the return value of a production that has not been generated results in an undefined value. For example:

```
X : A {int y = B;} B ; // invalid use of B
X : A {int y = A[2];} B A ; // invalid use of A[2]
X : A {int y = A;} B {int j = A + B;} ; // valid
```

The sequences produced by `randsequence` can be driven directly into a system, as a side effect of production generation, or the entire sequence can be generated for future processing. For example, the following function generates and returns a queue of random numbers in the range given by its arguments. The first and last queue item correspond to the lower and upper bounds, respectively. Also, the size of the queue is randomly selected based on the production weights.

```
function int[$] GenQueue(int low, int high);
  int[$] q;

  randsequence()
  TOP      : BOUND(low) LIST BOUND(high) ;
  LIST     : LIST ITEM := 8 { q = { q, ITEM }; }
            | ITEM := 2 { q = { q, ITEM }; }
            ;
  int ITEM : { return $urandom_range( low, high ); } ;

  BOUND(int b) : { q = { q, b }; } ;
endsequence
GenQueue = q;
endfunction
```

When the `randsequence` in function `GenQueue` executes, it generates the `TOP` production, which causes three productions to be generated: `BOUND` with argument `low`, `LIST`, and `BOUND` with argument `high`. The `BOUND` production simply appends its argument to the queue. The `LIST` production consists of a weighted `LIST ITEM` production and an `ITEM` production. The `LIST ITEM` production is generated with 80% probability, which causes the `LIST` production to be generated recursively, thereby postponing the generation of the `ITEM` production. The selection between `LIST ITEM` and `ITEM` is repeated until the `ITEM` production is selected, which terminates the `LIST` production. Each time the `ITEM` production is generated, it produces a random number in the indicated range, which is later appended to the queue.

The following example uses a `randsequence` block to produce random traffic for a DSL packet network:

```
class DSL; ... endclass // class that creates valid DSL packets
```

```
randsequence (STREAM)
  STREAM : GAP DATA := 80
          | DATA      := 20 ;

  DATA   : PACKET(0)      := 94 { transmit( PACKET ); }
          | PACKET(1)      := 6  { transmit( PACKET ); } ;

  DSL PACKET (bit bad) : { DSL d = new;
                          if( bad ) d.crc ^= 23;    // mangle crc
                          return d;
                          };
  GAP: { ## {$urandom_range( 1, 20 )}; };
endsequence
```

In this example, the traffic consists of a stream of (good and bad) data packets and gaps. The first production, `STREAM`, specifies that 80% of the time the traffic consists of a `GAP` followed by some `DATA` and 20% of the time it consists of just `DATA` (no `GAP`). The second production, `DATA`, specifies that 94% of all data packets are good packets and the remaining 6% are bad packets. The `PACKET` production implements the `DSL` packet creation; if the production argument is 1, then a bad packet is produced by mangling the `crc` of a valid `DSL` packet. Finally, the `GAP` production implements the transmission gaps by waiting a random number of cycles between 1 and 20.

19. Functional coverage

19.1 General

This clause describes the following:

- Defining coverage groups
- Defining coverage points
- Defining cross coverage
- Coverage options
- Coverage system tasks and system functions
- Coverage computation

19.2 Overview

Functional verification comprises a large portion of the resources required to design and validate a complex system. Often, the validation must be comprehensive without redundant effort. To minimize wasted effort, coverage is used as a guide for directing verification resources by identifying tested and untested portions of the design.

Coverage is defined as the percentage of verification objectives that have been met. It is used as a metric for evaluating the progress of a verification project in order to reduce the number of simulation cycles spent in verifying a design.

Broadly speaking, there are two types of coverage metrics: those that can be automatically extracted from the design code, such as code coverage, and those that are user-specified in order to tie the verification environment to the design intent or functionality. The latter form is referred to as *functional coverage* and is the topic of this clause.

Functional coverage is a user-defined metric that measures how much of the design specification, as enumerated by features in the test plan, has been exercised. It can be used to measure whether interesting scenarios, corner cases, specification invariants, or other applicable design conditions—captured as features of the test plan—have been observed, validated, and tested.

The key aspects of functional coverage are as follows:

- It is user-specified and is not automatically inferred from the design.
- It is based on the design specification (i.e., its intent) and is thus independent of the actual design code or its structure.

Because it is fully specified by the user, functional coverage requires more up-front effort (someone has to write the coverage model). Functional coverage also requires a more structured approach to verification. Although functional coverage can shorten the overall verification effort and yield higher quality designs, its shortcomings can impede its adoption.

The SystemVerilog functional coverage extensions address these shortcomings by providing language constructs for easy specification of functional coverage models. This specification can be efficiently executed by the SystemVerilog simulation engine, thus enabling coverage data manipulation and analysis tools that speed up the development of high-quality tests. The improved set of tests can exercise more corner cases and required scenarios, without redundant work.

The SystemVerilog functional coverage constructs enable the following:

- Coverage of variables and expressions, as well as cross coverage between them

- Automatic as well as user-defined coverage bins
- Associate bins with sets of values, transitions, or cross products
- Filtering conditions at multiple levels
- Events and sequences to automatically trigger coverage sampling
- Procedural activation and query of coverage
- Optional directives to control and regulate coverage

19.3 Defining the coverage model: **covergroup**

The **covergroup** construct encapsulates the specification of a coverage model. Each **covergroup** specification can include the following components:

- A clocking event that synchronizes the sampling of coverage points
- A set of coverage points
- Cross coverage between coverage points
- Optional formal arguments
- Coverage options

The **covergroup** construct is a user-defined type. The type definition is written once, and multiple instances of that type can be created in different contexts. Similar to a class, once defined, a **covergroup** instance can be created via the **new()** operator. A **covergroup** can be defined in a package, module, program, interface, checker, or class (see [Syntax 19-1](#)).

```

covergroup_declaration ::=
    covergroup covergroup_identifier [ ( [ tf_port_list ] ) ] [ coverage_event ] ;
    { coverage_spec_or_option }
    endgroup [ : covergroup_identifier ]
coverage_spec_or_option ::=
    {attribute_instance} coverage_spec
    | {attribute_instance} coverage_option ;
coverage_option ::=
    option.member_identifier = expression
    | type_option.member_identifier = constant_expression
coverage_spec ::=
    cover_point
    | cover_cross
coverage_event ::=
    clocking_event
    | with function sample ( [ tf_port_list ] )
    | @@ ( block_event_expression )
block_event_expression ::=
    block_event_expression or block_event_expression
    | begin hierarchical_btf_identifier
    | end hierarchical_btf_identifier
hierarchical_btf_identifier ::=
    hierarchical_tf_identifier
    | hierarchical_block_identifier
    | hierarchical_identifier [ class_scope ] method_identifier

```

Syntax 19-1—Covergroup syntax (excerpt from [Annex A](#))

The identifier associated with the **covergroup** declaration defines the name of the coverage model. Using this name, an arbitrary number of coverage model instances can be created. For example:

```
covergroup cg; ... endgroup
cg cg_inst = new;
```

The above example defines a **covergroup** named `cg`. An instance of `cg` is declared as `cg_inst` and created using the **new** operator.

A covergroup can specify an optional list of arguments as described in 13.5. When the covergroup specifies a list of formal arguments, its instances shall provide to the **new** operator all the actual arguments that are not defaulted. Actual arguments are evaluated when the **new** operator is executed. A **ref** argument allows a different variable to be sampled by each instance of a covergroup. Input arguments will not track the value of their arguments; they will use the value passed to the **new** operator.

An **output** or **inout** shall be illegal as a formal argument. Since a covergroup cannot modify any argument to the **new** operator, a **ref** argument will be treated the same as a read-only **const ref** argument. The formal arguments of a covergroup cannot be accessed using a hierarchical name (the formals cannot be accessed outside the covergroup declaration).

If a clocking event is specified, it defines the event at which coverage points are sampled. Because it is in the scope of the covergroup, the clocking event can be based on **ref** arguments of the covergroup. If an automatic variable is passed by reference, behavior is undefined. If a clocking event is not specified, users must procedurally trigger the coverage sampling via the built-in `sample()` method (see 19.8). The predefined `sample()` method accepts no arguments, however, users may override this by specifying as the triggering function a sample method with an argument list (see 19.8.1). If the overridden `sample()` method specifies a list of formal arguments then each call to the `sample()` method must provide all the actual arguments that are not defaulted. If the `coverage_event` is omitted, the coverage group shall specify the predefined `sample()` method.

Optionally, the **strobe** option can be used to modify the sampling behavior. When the strobe option is not set (the default), a coverage point is sampled the instant the clocking event takes place, as if the process triggering the event were to call the built-in `sample()` method. If the clocking event occurs multiple times in a time step, the coverage point will also be sampled multiple times. The strobe option (see 19.7.1) can be used to specify that coverage points are sampled in the Postponed region, thereby filtering multiple clocking events so that only one sample per time slot is taken. The **strobe** option only applies to the scheduling of samples triggered by a clocking event. It shall have no effect on procedural calls to the built-in `sample()` method.

As an alternative to a clocking event or a sample method, a coverage group accepts a block event expression to indicate that the coverage sample is to be triggered by the start or the end of execution of a given named block, task, function, or class method. Block event expressions that specify the **begin** keyword followed by a hierarchical identifier denoting a named block, task, function, or class method shall be triggered immediately before the corresponding block, task, function, or method begins executing its first statement. Block event expressions that specify the **end** keyword followed by a hierarchical identifier denoting a named block, task, function, or class method shall be triggered immediately after the corresponding block, task, function, or method executes its last statement. Block event expressions that specify the end of execution shall not be triggered if the block, task, function, or method is disabled.

A covergroup can contain one or more coverage points. A coverage point can cover a variable or an expression.

Each coverage point includes a set of bins associated with its sampled values or its value transitions. Bins associated with value sets are referred to as *state bins* while bins associated with value transitions are referred to as *transition bins*. The bins can be explicitly defined by the user or automatically created by the tool. Coverage points are discussed in detail in 19.5.

```
enum { red, green, blue } color;

covergroup g1 @(posedge clk);
  c: coverpoint color;
endgroup
```

The above example defines coverage group `g1` with a single coverage point associated with variable `color`. The value of the variable `color` is sampled at the indicated clocking event: the positive edge of signal `clk`. Because the coverage point does not explicitly define any bins, the tool automatically creates three bins, one for each possible value of the enumerated type. Automatic bins are described in [19.5.2](#).

A coverage group can also specify cross coverage between two or more coverage points or variables. Any combination of more than two variables or previously declared coverage points is allowed. For example:

```
enum { red, green, blue } color;
bit [3:0] pixel_adr, pixel_offset, pixel_hue;

covergroup g2 @(posedge clk);
  Hue: coverpoint pixel_hue;
  Offset: coverpoint pixel_offset;

  AxC: cross color, pixel_adr; // cross 2 variables (implicitly declared
                               // coverpoints)
  all: cross color, Hue, Offset; // cross 1 variable and 2 coverpoints
endgroup
```

The example above creates coverage group `g2` that includes two coverage points and two cross coverage items. Explicit coverage points labeled `Offset` and `Hue` are defined for variables `pixel_offset` and `pixel_hue`. SystemVerilog implicitly declares coverage points for variables `color` and `pixel_adr` in order to track their cross coverage. Implicitly declared coverage points are described in [19.6](#).

A coverage group can also specify one or more options to control and regulate how coverage data are structured and collected. Coverage options can be specified for the coverage group as a whole or for specific items within the coverage group, that is, any of its coverage points or crosses. In general, a coverage option specified at the covergroup level applies to all of its items unless overridden by them. Coverage options are described in [19.7](#).

19.4 Using covergroup in classes

By embedding a coverage group within a class definition, the covergroup provides a simple way to cover a subset of the class properties. This integration of coverage with classes provides an intuitive and expressive mechanism for defining the coverage model associated with a class. For example:

In class `xyz`, defined below, members `m_x` and `m_y` are covered using an embedded **covergroup**:

```
class xyz;
  bit [3:0] m_x;
  int m_y;
  bit m_z;

  covergroup cov1 @m_z; // embedded covergroup
    coverpoint m_x;
    coverpoint m_y;
  endgroup
```

```

    function new(); cov1 = new; endfunction
endclass

```

In this example, data members `m_x` and `m_y` of class `xyz` are sampled on every change of data member `m_z`.

A **covergroup** declaration within a class is an *embedded covergroup* declaration. An embedded **covergroup** declaration declares an anonymous **covergroup** type and an instance variable of the anonymous type. The *covergroup_identifier* defines the name of the instance variable. In the above example, a variable `cov1` (of the anonymous coverage group) is implicitly declared.

An embedded covergroup can define a coverage model for protected and local class properties without any changes to the class data encapsulation. Class members can be used in coverpoint expressions or can be used in other coverage constructs, such as conditional guards or option initialization.

A class can have more than one covergroup. The following example shows two coverage groups in class `MC`.

```

class MC;
    logic [3:0] m_x;
    local logic m_z;
    bit m_e;
    covergroup cv1 @(posedge clk); coverpoint m_x; endgroup
    covergroup cv2 @m_e ; coverpoint m_z; endgroup
endclass

```

In **covergroup** `cv1`, public class member variable `m_x` is sampled at every positive edge of signal `clk`. Local class member `m_z` is covered by another **covergroup** `cv2`. Each coverage group is sampled by a different clocking event.

An embedded covergroup variable may only be assigned in the `new` method. An embedded coverage group can be explicitly instantiated in the `new` method. If it is not, then the coverage group is not created and no data will be sampled.

Below is an example of an embedded coverage group that does not have any passed-in arguments and uses explicit instantiation to synchronize with another object:

```

class Helper;
    int m_ev;
endclass

class MyClass;
    Helper m_obj;
    int m_a;
    covergroup Cov @(m_obj.m_ev);
        coverpoint m_a;
    endgroup

    function new();
        m_obj = new;

        Cov = new; // Create embedded covergroup after creating m_obj
    endfunction
endclass

```

In this example, **covergroup** `Cov` is embedded within class `MyClass`, which contains an object of type `Helper` class, called `m_obj`. The clocking event for the embedded coverage group refers to data member `m_ev` of `m_obj`. Because the coverage group `Cov` uses `m_obj`, `m_obj` must be instantiated before `Cov`.

Therefore, the coverage group `Cov` is instantiated after instantiating `m_obj` in the class constructor. As shown above, the instantiation of an embedded coverage group is done by assigning the result of the `new` operator to the coverage group identifier.

The following example shows how arguments passed in to an embedded coverage group can be used to set a coverage option of the coverage group:

```
class C1;
  bit [7:0] x;

  covergroup cv (int arg) @(posedge clk);
    option.at_least = arg;
    coverpoint x;
  endgroup

  function new(int p1);
    cv = new(p1);
  endfunction
endclass

initial begin
  C1 obj = new(4);
end
```

19.5 Defining coverage points

A covergroup can contain one or more coverage points. A coverage point specifies an integral expression that is to be covered. Each coverage point includes a set of bins associated with the sampled values or value transitions of the covered expression. The bins can be explicitly defined by the user or automatically created by SystemVerilog. The syntax for specifying coverage points is given in [Syntax 19-2](#). Evaluation of the coverage point expression (and of its enabling `iff` condition, if any) takes place when the covergroup is sampled. The expression shall be evaluated in a procedural context, and therefore it shall be legal for the expression to make access through a virtual interface (see [25.9](#)).

```
cover_point ::= // from A.2.11
  [ cover_point_identifier : ] coverpoint expression [ iff ( expression ) ] bins_or_empty
bins_or_empty ::=
  { {attribute_instance} { bins_or_options ; } }
  | ;
bins_or_options ::=
  coverage_option
  | [ wildcard ] bins_keyword bin_identifier [ [ [ expression ] ] ] = { open_range_list } [ iff ( expression ) ]
  | [ wildcard ] bins_keyword bin_identifier [ [ ] ] = trans_list [ iff ( expression ) ]
  | bins_keyword bin_identifier [ [ [ expression ] ] ] = default [ iff ( expression ) ]
  | bins_keyword bin_identifier = default sequence [ iff ( expression ) ]
bins_keyword ::= bins | illegal_bins | ignore_bins
open_range_list ::= open_value_range { , open_value_range }
open_value_range ::= value_range24
```

²⁴) It shall be legal to use the `$` primary in an `open_value_range` of the form `[expression : $]` or `[$: expression]`.

A **coverpoint** coverage point creates a hierarchical scope and can be optionally labeled. If the label is specified, then it designates the name of the coverage point. This name can be used to add this coverage point to a cross coverage specification or to access the methods of the coverage point. If the label is omitted and the coverage point is associated with a single variable, then the variable name becomes the name of the coverage point. Otherwise, an implementation can generate a name for the coverage point only for the purposes of coverage reporting, that is, generated names cannot be used within the language.

A coverpoint name has limited visibility. An identifier can only refer to a coverpoint in the following contexts:

- In the coverpoint list of a **cross** declaration (see [19.6](#)),
- In a hierarchical name where the prefix specifies the name of a covergroup variable. For example, `cov1.cp.option.weight` where `cov1` is the name of a covergroup variable and `cp` is the name of a coverpoint declared within the covergroup.
- Following `::`, where the left operand of the scope resolution operator refers to a covergroup. For example, `covtype :: cp :: type_option.weight`.

For example:

```
covergroup cg ( ref int x , ref int y, input int c);

  coverpoint x;           // creates coverpoint "x" covering the formal "x"
  x: coverpoint x;       // INVALID: coverpoint label "x" already exists
  b: coverpoint y;       // creates coverpoint "b" covering the formal "y"

  c: coverpoint x;       // creates coverpoint "c" covering the formal "x"

  option.weight = c;     // set weight of "cg" to value of formal "c"

  d: coverpoint x {
    option.weight = 2;   // set the weight of coverpoint "d"
  }
  d.option.weight = 2;   // INVALID use of "d", also syntax error

  cross x, y {           // Creates implicit coverpoint "y" covering
                        // the formal "y". Then creates a cross of
                        // coverpoints "x", "y"
    option.weight = c;   // set weight of cross to value of formal "c"
  }
  b: cross y, x;         // INVALID: coverpoint label "b" already exists

endgroup
```

A coverage point can sample the values that correspond to a particular scheduling region (see [Clause 4](#)) by specifying a clocking block signal. Thus, a coverage point that denotes a clocking block signal will sample the values made available by the clocking block. If the clocking block specifies a skew of `#1step`, the coverage point will sample the signal values from the Preponed region. If the clocking block specifies a skew of `#0`, the coverage point will sample the signal values from the Observed region.

The expression within the **iff** construct specifies an optional condition that disables coverage for that **coverpoint**. If the guard expression evaluates to false at a sampling point, the coverage point is ignored. For example:

```
covergroup g4;
  coverpoint s0 iff(!reset);
endgroup
```

In the preceding example, coverage point `s0` is covered only if the value `reset` is false.

A coverage point bin associates a name and a count with a set of values or a sequence of value transitions. If the bin designates a set of values, the count is incremented every time the coverage point matches one of the values in the set. If the bin designates a sequence of value transitions, the count is incremented every time the coverage point matches the entire sequence of value transitions.

The bins for a coverage point can be automatically created by SystemVerilog or explicitly defined using the **bins** construct to name each bin. If the bins are not explicitly defined, they are automatically created by SystemVerilog. The number of automatically created bins can be controlled using the `auto_bin_max` coverage option. Coverage options are described in [19.7](#).

The **bins** construct allows creating a separate bin for each value in the given range list or a single bin for the entire range of values. To create a separate bin for each value (an array of bins), the square brackets, `[]`, shall follow the bin name. To create a fixed number of bins for a set of values, a number can be specified inside the square brackets. The *open_range_list* used to specify the set of values associated with a bin shall be constant expressions (see [11.2.1](#)), instance constants (for classes only), or non-**ref** arguments to the coverage group. It shall be legal to use the `$` primary in an *open_value_range* of the form `[expression : $]` or `[$: expression]`.

If a fixed number of bins is specified and that number is smaller than the specified number of values, then the possible bin values are uniformly distributed among the specified bins. The first ‘n’ specified values are assigned to the first bin, the next ‘n’ specified values are assigned to the next bin, etc. Duplicate values are retained; thus the same value can be assigned to multiple bins. If the number of values is not divisible by the number of bins, then the last bin will include the remaining items. For example:

```
bins fixed [4] = { [1:10], 1, 4, 7 };
```

The 13 possible values are distributed as follows: `<1,2,3>`, `<4,5,6>`, `<7,8,9>`, `<10,1,4,7>`. If the number of bins exceeds the number of values, then some of the bins will be empty.

The expression within the **iff** construct at the end of a bin definition provides a per-bin guard condition. If the expression is false at a sampling point, the count for the bin is not incremented.

The **default** specification defines a bin that is associated with none of the defined value bins. The default bin catches the values of the coverage point that do not lie within any of the defined bins. However, the coverage calculation for a coverage point shall not take into account the coverage captured by the default bin. The default bin is also excluded from cross coverage (see [19.6](#)). The default is useful for catching unplanned or invalid values. The **default sequence** form can be used to catch all transitions (or sequences) that do not lie within any of the defined transition bins (see [19.5.1](#)). The **default sequence** specification does not accept multiple transition bins (i.e., the `[]` notation is not allowed).

```
bit [9:0] v_a;

covergroup cg @(posedge clk);

    coverpoint v_a
    {
        bins a = { [0:63], 65 };
        bins b[] = { [127:150], [148:191] }; // note overlapping values
        bins c[] = { 200, 201, 202 };
        bins d = { [1000:$] };
        bins others[] = default;
    }
endgroup
```

In the example above, the first **bins** construct associates bin *a* with the values of variable *v_a* between 0 and 63 and the value 65. The second **bins** construct creates a set of 65 bins *b*[127], *b*[128], . . . *b*[191]. Likewise, the third **bins** construct creates 3 bins: *c*[200], *c*[201], and *c*[202]. The fourth **bins** construct associates bin *d* with the values between 1000 and 1023 (*\$* represents the maximum value of *v_a*). Every value that does not match bins *a*, *b*[], *c*[], or *d* is added into its own distinct bin.

A **default** or **default sequence** bin specification cannot be explicitly ignored (see 19.5.4). It shall be an error for bins designated as **ignore_bins** to also specify a **default** or **default sequence**.

Generic coverage groups can be written by passing their traits as arguments to the constructor. For example:

```
covergroup cg (ref int ra, input int low, int high ) @(posedge clk);

    coverpoint ra // sample variable passed by reference
    {
        bins good = { [low : high] };
        bins bad[] = default;
    }
endgroup

...
int va, vb;

cg c1 = new( va, 0, 50 ); // cover variable va in the range 0 to 50
cg c2 = new( vb, 120, 600 ); // cover variable vb in the range 120 to 600
```

The example above defines a coverage group, *cg*, in which the signal to be sampled and the extent of the coverage bins are specified as arguments. Later, two instances of the coverage group are created; each instance samples a different signal and covers a different range of values.

19.5.1 Specifying bins for transitions

The syntax for specifying transition bins ([Syntax 19-3](#)) accepts a subset of the sequence syntax described in [16.9](#):

```
bins_or_options ::= //from A.2.11
...
| [ wildcard ] bins_keyword bin_identifier [ [ [ expression ] ] ] = { open_range_list } [ iff ( expression ) ]
| [ wildcard ] bins_keyword bin_identifier [ [ ] ] = trans_list [ iff ( expression ) ]
...
bins_keyword ::= bins | illegal_bins | ignore_bins
range_list ::= value_range { , value_range }
open_range_list ::= open_value_range { , open_value_range }
trans_list ::= ( trans_set ) { , ( trans_set ) }
trans_set ::= trans_range_list { => trans_range_list }
trans_range_list ::=
    trans_item
    | trans_item [* repeat_range ]
    | trans_item [-> repeat_range ]
    | trans_item [= repeat_range ]
trans_item ::= range_list
```

```
repeat_range ::=  
    expression  
    | expression : expression
```

Syntax 19-3—Transition bin syntax (excerpt from [Annex A](#))

A *trans_list* specifies one or more sets of ordered value transitions of the coverage point. A single value transition is thus specified as follows:

```
value1 => value2
```

It represents the value of coverage point at two successive sample points, that is, *value1* followed by *value2* at the next sample point.

A sequence of transitions is represented as follows:

```
value1 => value3 => value4 => value5
```

In this case, *value1* is followed by *value3*, followed by *value4*, and followed by *value5*. A sequence can be of any arbitrary length.

A set of transitions can be specified as follows:

```
range_list1 => range_list2
```

This specification expands to transitions between each value in *range_list1* and each value in *range_list2*. For example:

```
1, 5 => 6, 7
```

specifies the following four transitions:

```
( 1=>6 ), ( 1=>7 ), ( 5=>6 ), ( 5=>7 )
```

Consecutive repetitions of transitions are specified using:

```
trans_item [* repeat_range ]
```

Here, *trans_item* is repeated for *repeat_range* times. For example:

```
3 [* 5]
```

is the same as

```
3=>3=>3=>3=>3
```

An example of a range of repetitions is as follows:

```
3 [* 3:5]
```

which is the same as

```
( 3=>3=>3 ), ( 3=>3=>3=>3 ), ( 3=>3=>3=>3=>3 )
```

The goto repetition is specified using: *trans_item* [-> *repeat_range*]. The required number of occurrences of a particular value is specified by the *repeat_range*. Any number of sample points can occur before the first occurrence of the specified value and any number of sample points can occur between each occurrence of the specified value. The transition following the goto repetition must immediately follow the last occurrence of the repetition. For example:

3 [-> 3]

is the same as

...=>3...=>3...=>3

where the dots (...) represent any transition that does not contain the value 3.

A goto repetition followed by an additional value is represented as follows:

1 => 3 [-> 3] => 5

is the same as

1...=>3...=>3...=>3 =>5

The nonconsecutive repetition is specified using: *trans_item* [= *repeat_range*]. The required number of occurrences of a particular value is specified by the *repeat_range*. Any number of sample points can occur before the first occurrence of the specified value and any number of sample points can occur between each occurrence of the specified value. The transition following the nonconsecutive repetition may occur after any number of sample points so long as the repetition value does not occur again.

For example:

3 [= 2]

is same as

...=>3...=>3

A nonconsecutive repetition followed by an additional value is represented as follows:

1 => 3 [=2] => 6

is the same as

1...=>3...=>3...=>6

A *trans_list* specifies one or more sets of ordered value transitions of the coverage point. If the sequence of value transitions of the coverage point matches any complete sequence in the *trans_list*, the coverage count of the corresponding bin is incremented. For example:

```
bit [4:1] v_a;

covergroup cg @(posedge clk);

    coverpoint v_a
    {
        bins sa = (4 => 5 => 6), ([7:9],10=>11,12);
        bins sb[] = (4=> 5 => 6), ([7:9],10=>11,12);
    }

```

```

    bins sc = (12 => 3 [-> 1]);
    bins allother = default sequence ;
  }
endgroup

```

The example above defines three transition coverage bins. The first **bins** construct associates the following sequences with bin *sa*: 4=>5=>6, or 7=>11, 8=>11, 9=>11, 10=>11, 7=>12, 8=>12, 9=>12, 10=>12. The second **bins** construct associates an individual bin with each of the above sequences: *sb*[4=>5=>6], ..., *sb*[10=>12]. The third **bins** construct associates the unbounded sequence 12=>...=>3 with bin *sc*. The bin *allother* is incremented when none of the coverpoint's other nondefault sequence transition bins increments and none of the coverpoint's previously pending transition bins remains pending. For example, consider the following sequence of sampled values:

```
4 5 7 11 8 12 2 2 3
```

The bin *allother* increments twice. The bin *allother* increments on the sample of 7 because 5=>7 causes the matching of the pending sequence 4=>5=>6 to fail for bins *sa* and *sb*[4=>5=>6], and there were no other previously pending sequences or incremented bins. The bin *allother* increments on the sample of 8 since no other bin increments on the transition 11=>8 and no other sequences were previously pending. The bin *allother* does not increment during the transitions 12=>2=>2 because the bin *sc* remains pending throughout.

Transitions that specify sequences of unbounded or undetermined varying length cannot be used with the multiple bins construct (the [] notation). For example, the length of the transition 3[=2], which uses non-consecutive repetition, is unbounded and can vary during simulation. An attempt to specify multiple bins with such sequences shall result in an error.

A transition bin is incremented every time the sequence of value transitions of its corresponding coverage point matches a complete sequence, even when the sequences overlap. For example, given the definition

```

covergroup sg @(posedge clk);
  coverpoint v
  {
    bins b2 = ( 2 [-> 3:5] );           // 3 to 5 nonconsecutive 2's
    bins b3 = ( 3 [-> 3:5] );           // 3 to 5 nonconsecutive 3's
    bins b5 = ( 5 [* 3] );              // 3 consecutive 5's
    bins b6 = ( 1 => 3 [-> 4:6] => 1);   // 1 followed by
                                           // 4 to 6 goto nonconsecutive 3's
                                           // followed immediately by a 1
    bins b7 = ( 1 => 2 [= 3:6] => 5);   // 1 followed by
                                           // 3 to 6 non consecutive 2's
                                           // followed sometime later by a 5
  }
endgroup

```

and the sequence of sampled values for coverpoint variable *v*

```

1st Sample
|           5th           10th           15th
|           |           |           |
1 4 3 2 3 3 2 2 3 2 3 1 5 5 5 5 5 5

```

the above sequence causes transition bin *b2* to be incremented on the 8th sample (3 nonconsecutive twos), and transition bin *b3* to be incremented on the 6th sample (3 nonconsecutive threes). Likewise, transition bin *b2* is incremented on the 10th sample, and transition bin *b3* is incremented on the 9th and 11th samples.

Transition bin `b5` is incremented on the 15th, 16th, 17th, and 18th samples. Transition bin `b6` is incremented on the 12th sample. Transition bin `b7` is incremented on the 13th sample.

A transition bin is incremented at most once per sample. In the preceding example, on the 10th sample, the transition bin `b2` is incremented only once (1 is added to the bin count).

Transition bin specifications of length 0 shall be illegal. These are transition bin specifications containing a *trans_set* production of a single *value_range*, e.g., (0) or ([0:1]), or a single *value_range* with a *repeat_range* evaluating to 1, e.g., (0[*1]) or ([0:1][*1]).

19.5.2 Automatic bin creation for coverage points

If a coverage point does not define any bins, SystemVerilog automatically creates state bins. This provides an easy-to-use mechanism for binning different values of a coverage point. Users can either let the tool automatically create state bins for coverage points or explicitly define named bins for each coverage point.

When the automatic bin creation mechanism is used, SystemVerilog creates N bins to collect the sampled values of a coverage point. The value N is determined as follows:

- For an **enum** coverage point, N is the cardinality of the enumeration.
- For any other integral coverage point, N is the minimum of 2^M and the value of the `auto_bin_max` option, where M is the number of bits needed to represent the coverage point.

If the number of automatic bins is smaller than the number of possible values ($N < 2^M$), then the 2^M values are uniformly distributed in the N bins. If the number of values, 2^M , is not divisible by N , then the last bin will include the additional remaining items. For example, if M is 3 and N is 3, then the eight possible values are distributed as follows: <0:1>, <2:3>, <4,5,6,7>.

Automatically created bins only consider 2-state values; sampled values containing **X** or **Z** are excluded.

SystemVerilog implementations can impose a limit on the number of automatic bins. See the [19.7](#) for the default value of `auto_bin_max`.

Each automatically created bin will have a name of the form of `auto[value]` where `value` is either a single coverage point value or the range of coverage point values included in the bin—in the form `low:high`. For enumerated types, `value` is the named constant associated with a particular enumerated value.

19.5.3 Wildcard specification of coverage point bins

By default, a value or transition bin definition can specify 4-state values. When a bin definition includes an **X** or **Z**, it indicates that the bin count should only be incremented when the sampled value has an **X** or **Z** in the same bit positions, i.e., the comparison is done using `===`. A **wildcard** bin definition causes all **X**, **Z**, or **?** to be treated as wildcards for **0** or **1**. For example:

```
wildcard bins g12_15 = { 4'b11?? };
```

The count of bin `g12_15` is incremented when the sampled variable is between 12 and 15:

```
1100    1101    1110    1111
```

Similarly, transition bins can define **wildcard** bins. For example:

```
wildcard bins T0_3 = (2'b0x ==> 2'b1x);
```

The count of transition bin `T0_3` is incremented for the following transitions (as if by (0, 1=>2, 3)):

```
00 => 10    00 => 11    01 => 10    01 => 11
```

A wildcard bin definition only considers 2-state values; sampled values containing **X** or **Z** are excluded.

19.5.4 Excluding coverage point values or transitions

A set of values or transitions associated with a coverage point can be explicitly excluded from coverage by specifying them as **ignore_bins**. For example:

```
covergroup cg23;  
  coverpoint a  
  {  
    ignore_bins ignore_vals = {7,8};  
    ignore_bins ignore_trans = (1=>3=>5);  
  }  
endgroup
```

All values or transitions associated with ignored bins are excluded from coverage. For state bins, each ignored value is removed from the set of values associated with any coverage bin. For transition bins, any covered sequence is removed when it cannot be matched without also matching an ignored sequence. (For example, the ignored sequence 2=>3 would remove the covered sequence 1=>2=>3=>4.) The removal of ignored values shall occur after the distribution of values to the specified bins. An ignored value has no effect on a transition that includes the value. Ignored transition bins cannot specify a sequence of unbounded or undetermined varying length.

The above may result in a bin that is associated with no values or sequences. Such empty bins are excluded from coverage (see [19.11](#)).

19.5.5 Specifying illegal coverage point values or transitions

A set of values or transitions associated with a coverage point can be marked as illegal by specifying them as **illegal_bins**. For example:

```
covergroup cg3;  
  coverpoint b  
  {  
    illegal_bins bad_vals = {1,2,3};  
    illegal_bins bad_trans = (4=>5=>6);  
  }  
endgroup
```

All values or transitions associated with illegal bins are excluded from coverage. For state bins, each illegal value is removed from the set of values associated with any coverage bin. For transition bins, any covered sequence is removed when it cannot be matched without also matching an illegal sequence. (For example, the illegal sequence 2=>3 would remove the covered sequence 1=>2=>3=>4.) The removal of illegal values shall occur after the distribution of values to the specified bins. If an illegal value or transition occurs, a run-time error is issued. Illegal bins take precedence over any other bins, that is, they will result in a run-time error even if they are also included in another bin. Specifying an illegal value has no effect on a transition that includes the value. Illegal transition bins cannot specify a sequence of unbounded or undetermined varying length.

The above may result in a bin that is associated with no values or sequences. Such empty bins are excluded from coverage (see [19.11](#)).

19.5.6 Value resolution

A coverpoint expression and the expressions in a **bins** construct are involved in comparison operations in order to determine into which bins a particular value falls. Let *e* be the coverpoint expression and *b* be an expression in a **bins open_range_list**. The following rules shall apply when evaluating *e* and *b*: For **wildcard** bins, *x* and *z* values in *b* shall be treated as all possible 0 and 1 values prior to applying these rules.

- a) *e* shall be self-determined
- b) *b* shall be evaluated as though it were the right-hand side of an assignment to a variable whose type is **type**(*e*). Enumeration values in expressions *b* and *e* shall first be treated as being in an expression context. This implies that the type of an enumeration value is the base type of the enumeration and not the enumeration type itself. An implementation shall issue a warning under the following conditions:
 - 1) If *e* is unsigned and *b* is signed with a negative value.
 - 2) If assigning *b* to a variable of type **type**(*e*) would yield a value that is not equal to *b* under normal comparison rules for **==**.
 - 3) If *b* yields a value with any *x* or *z* bits. This rule does not apply to **wildcard** bins because *x* and *z* shall be treated as 0 and 1 as described above.

If a warning is issued for a bins element, the following rules shall apply:

- If an element of a **bins open_range_list** is a singleton value *b*, the element shall not participate in the bins values.
- If an element of a **bins open_range_list** is a range [*b1* : *b2*] and either *b1* or *b2* contains any *x* or *z* bits or every value in the range would generate a warning, then the element shall not participate in the bins values.
- If an element of a **bins open_range_list** is a range [*b1* : *b2*] and there exists at least one value in the range for which a warning would not be issued then the range shall be treated as containing the intersection of the values in the range and the values expressible by **type**(*e*).

Examples:

```

bit [2:0] p1;           // type expresses values in the range 0 to 7
bit signed [2:0] p2;   // type expresses values in the range -4 to 3
covergroup g1 @(posedge clk);
  coverpoint p1 {
    bins b1 = { 1, [2:5], [6:10] };
    bins b2 = { -1, [1:10], 15 };
  }
  coverpoint p2 {
    bins b3 = {1, [2:5], [6:10] };
    bins b4 = { -1, [1:10], 15 };
  }
endgroup

```

- For *b1*, a warning is issued for the range [6:10]. *b1* is treated as though it had the specification {1, [2:5], [6:7]}.
- For *b2*, a warning is issued for the range [1:10] and for the values -1 and 15. *b2* is treated as though it had the specification { [1:7] }.
- For *b3*, a warning is issued for the ranges [2:5] and [6:10]. *b3* is treated as though it had the specification { 1, [2:3] }.
- For *b4*, a warning is issued for the range [1:10] and for the value 15. *b2* is treated as though it had the specification { -1, [1:3] }.

19.6 Defining cross coverage

A coverage group can specify cross coverage between two or more coverage points or variables. Cross coverage is specified using the **cross** construct. When a variable *v* is part of a cross coverage, SystemVerilog implicitly creates a coverage point for the variable, as if it had been created by the statement `coverpoint v;`. Thus, a cross involves only coverage points. Expressions cannot be used directly in a cross; a coverage point must be explicitly defined first.

The syntax for specifying cross coverage is given in [Syntax 19-4](#).

```

cover_cross ::=
    [ cross_identifier : ] cross list_of_coverpoints [ iff ( expression ) ] select_bins_or_empty
list_of_coverpoints ::= cross_item , cross_item { , cross_item }
cross_item ::=
    cover_point_identifier
    | variable_identifier
select_bins_or_empty ::=
    { { bins_selection_or_option ; } }
    | ;
bins_selection_or_option ::=
    { attribute_instance } coverage_option
    | { attribute_instance } bins_selection
bins_selection ::= bins_keyword bin_identifier = select_expression [ iff ( expression ) ]
select_expression ::=
    select_condition
    | ! select_condition
    | select_expression && select_expression
    | select_expression || select_expression
    | ( select_expression )
select_condition ::= binsof ( bins_expression ) [ intersect { open_range_list } ]
bins_expression ::=
    variable_identifier
    | cover_point_identifier [ . bin_identifier ]
open_range_list ::= open_value_range { , open_value_range }
open_value_range ::= value_range24

```

²⁴) It shall be legal to use the **\$** primary in an open_value_range of the form [expression : \$] or [\$: expression].

Syntax 19-4—Cross coverage syntax (excerpt from [Annex A](#))

The label for a **cross** declaration provides an optional name. The label also creates a hierarchical scope for the **bins** defined within the cross.

A **cross** name has limited visibility. An identifier can only refer to a **cross** in the following contexts:

- In a hierarchical name where the prefix specifies the name of a covergroup variable. For example, `cov1.crs.option.weight` where `cov1` is the name of a covergroup variable and `crs` is the name of a **cross** declared within the covergroup.
- Following `::` where the left operand of the scope resolution operator refers to a covergroup. For example, `covtype :: crs :: type_option.weight`.

The expression within the optional **iff** provides a conditional guard for the cross coverage. If at any sample point, the condition evaluates to false, the cross coverage is ignored. The expression within the optional **iff** construct at the end of a cross bin definition provides a per-bin guard condition. If the expression is false, the cross bin is ignored.

Cross coverage of a set of N coverage points is defined as the coverage of all combinations of all bins associated with the N coverage points, that is, the Cartesian product of the N sets of coverage point bins. For example:

```

bit [3:0] a, b;

covergroup cov @(posedge clk);
    aXb : cross a, b;
endgroup

```

The coverage group `cov` in the example above specifies the cross coverage of two 4-bit variables, `a` and `b`. SystemVerilog implicitly creates a coverage point for each variable. Each coverage point has 16 bins, namely `auto[0]...auto[15]`. The cross of `a` and `b` (labeled `aXb`), therefore, has 256 cross products, and each cross product is a bin of `aXb`.

Cross coverage between expressions previously defined as coverage points is also allowed. For example:

```

bit [3:0] a, b, c;

covergroup cov2 @(posedge clk);
    BC: coverpoint b+c;
    aXb : cross a, BC;
endgroup

```

The coverage group `cov2` has the same number of cross products as the previous example, but in this case, one of the coverage points is the expression `b+c`, which is labeled `BC`.

```

bit [31:0] a_var;
bit [3:0] b_var;

covergroup cov3 @(posedge clk);
    A: coverpoint a_var { bins yy[] = { [0:9] }; }
    CC: cross b_var, A;
endgroup

```

The coverage group `cov3` crosses variable `b_var` with coverage point A (labeled `CC`). Variable `b_var` automatically creates 16 bins (`auto[0]...auto[15]`). Coverage point A explicitly creates 10 bins (`yy[0]...yy[9]`). The cross of two coverage points creates $16 \times 10 = 160$ cross product bins, namely the following pairs:

```

<auto[0], yy[0]>
<auto[0], yy[1]>
...
<auto[0], yy[9]>
<auto[1], yy[0]>
...
<auto[15], yy[9]>

```

No cross coverage bins shall be created for coverpoint bins that are specified as **default**, **ignored**, or **illegal** bins.

Cross coverage is allowed only between coverage points defined within the same coverage group. Coverage points defined in a coverage group other than the one enclosing the cross cannot participate in a cross. Attempts to cross items from different coverage groups shall result in a compiler error.

In addition to specifying the coverage points that are crossed, SystemVerilog includes a powerful set of operators that allow defining cross coverage bins. Cross coverage bins can be specified in order to group together a set of cross products. A cross coverage bin associates a name and a count with a set of cross products. The count of the bin is incremented every time any of the cross products match, i.e., every coverage point in the cross matches its corresponding bin in the cross product.

User-defined bins for cross coverage are defined using bin select expressions. The syntax for defining these bin select expressions is given in [Syntax 19-4](#).

User-defined cross bins and automatically-generated bins can co-exist in the same cross. Automatically-generated bins are retained for those cross products which do not intersect cross products specified by any user-defined cross bin.

Consider the following example code:

```

int i,j;
covergroup ct;
  coverpoint i { bins i[] = { [0:1] }; }
  coverpoint j { bins j[] = { [0:1] }; }
  x1: cross i,j;
  x2: cross i,j {
    bins i_zero = binsof(i) intersect { 0 };
  }
endgroup

```

Cross x1 has the following bins:

```

<i[0],j[0]>
<i[1],j[0]>
<i[0],j[1]>
<i[1],j[1]>

```

Cross x2 has the following bins:

```

i_zero          // user-specified bin for <i[0],j[0]> and <i[0],j[1]>
<i[1],j[0]>     // an automatically-generated bin that is retained
<i[1],j[1]>     // an automatically-generated bin that is retained

```

The automatically-generated cross bins (which are the same as the set given above for cross x1) are retained for those bins that do not overlap the explicitly-declared cross bins. In this particular case, since the explicitly declared bin covers all cases for which $i == 0$, the cross will have the explicitly declared bin (*i_zero*) plus automatically generated bins for cases where $i != 0$.

The **binsof** construct yields the bins of its expression, which can be either a coverage point (explicitly defined or implicitly defined for a single variable) or a coverage point bin. The resulting bins can be further selected by including (or excluding) only the bins whose associated values intersect a desired set of values. The desired set of values can be specified using a comma-separated list of *open_value_range* as shown in [Syntax 19-4](#). For example, the select expression

```

binsof( x ) intersect { y }

```

denotes the bins of coverage point x whose values intersect the range given by y . Its negated form

```
! binsof(  $x$  ) intersect {  $y$  }
```

denotes the bins of coverage point x whose values do not intersect the range given by y .

The *open_value_range* syntax can specify a single value, a range of values, or an open range, which denotes the following:

```
[ $ : value ] => The set of values less than or equal to value  
[ value : $ ] => The set of values greater or equal to value
```

The bins selected can be combined with other selected bins using the logical operators **&&** and **||**.

19.6.1 Example of user-defined cross coverage and select expressions

```
bit [7:0] v_a, v_b;  
  
covergroup cg @(posedge clk);  
  
  a: coverpoint v_a  
  {  
    bins a1 = { [0:63] };  
    bins a2 = { [64:127] };  
    bins a3 = { [128:191] };  
    bins a4 = { [192:255] };  
  }  
  
  b: coverpoint v_b  
  {  
    bins b1 = {0};  
    bins b2 = { [1:84] };  
    bins b3 = { [85:169] };  
    bins b4 = { [170:255] };  
  }  
  
  c : cross a, b  
  {  
    bins c1 = ! binsof(a) intersect {[100:200]}; // 4 cross products  
    bins c2 = binsof(a.a2) || binsof(b.b2); // 7 cross products  
    bins c3 = binsof(a.a1) && binsof(b.b4); // 1 cross product  
  }  
endgroup
```

The example above defines a coverage group named `cg` that samples its coverage points on the positive edge of signal `clk` (not shown). The coverage group includes two coverage points, one for each of the two 8-bit variables, `v_a` and `v_b`. Coverage point `a` associated with variable `v_a` defines four equal-sized bins for each possible value of variable `v_a`. Likewise, coverage point `b` associated with variable `v_b` defines four bins for each possible value of variable `v_b`. Cross definition `c` specifies the cross coverage of the two coverage points `a` and `b`. If the cross coverage of coverage points `a` and `b` were defined without any additional cross bins (select expressions), then cross coverage of `a` and `b` would include 16 cross products corresponding to all combinations of bins `a1` through `a4` with bins `b1` through `b4`, that is, cross products `<a1,b1>`, `<a1,b2>`, `<a1,b3>`, `<a1,b4>`...`<a4,b1>`, `<a4,b2>`, `<a4,b3>`, `<a4,b4>`.

The first user-defined cross bin, *c1*, specifies that *c1* should include only cross products of coverage point *a* that do not intersect the value range of 100 to 200. This select expression excludes bins *a2*, *a3*, and *a4*. Thus, *c1* will cover only four cross products of $\langle a1, b1 \rangle$, $\langle a1, b2 \rangle$, $\langle a1, b3 \rangle$, and $\langle a1, b4 \rangle$.

The second user-defined cross bin, *c2*, specifies that bin *c2* should include only cross products whose values are covered by bin *a2* of coverage point *a* or cross products whose values are covered by bin *b2* of coverage point *b*. This select expression includes the following seven cross products: $\langle a2, b1 \rangle$, $\langle a2, b2 \rangle$, $\langle a2, b3 \rangle$, $\langle a2, b4 \rangle$, $\langle a1, b2 \rangle$, $\langle a3, b2 \rangle$, and $\langle a4, b2 \rangle$.

The final user-defined cross bin, *c3*, specifies that *c3* should include only cross products whose values are covered by bin *a1* of coverage point *a* and cross products whose values are covered by bin *b4* of coverage point *b*. This select expression includes only one cross product: $\langle a1, b4 \rangle$.

Additionally, the cross retains those automatically-generated bins that represent cross products not intersecting any of the user-defined bins. There are 6 of these: $\langle a3, b1 \rangle$, $\langle a4, b1 \rangle$, $\langle a3, b3 \rangle$, $\langle a4, b3 \rangle$, $\langle a3, b4 \rangle$, and $\langle a4, b4 \rangle$.

When select expressions are specified on transition bins, the **binsof** operator uses the last value of the transition.

19.6.2 Excluding cross products

A group of bins can be excluded from coverage by specifying a select expression using **ignore_bins**. For example:

```
covergroup yy;  
  cross a, b  
  {  
    ignore_bins ignore = binsof(a) intersect { 5, [1:3] };  
  }  
endgroup
```

All cross products that satisfy the select expression are excluded from coverage. Ignored cross products are excluded even if they are included in other cross coverage bins of the enclosing cross.

19.6.3 Specifying illegal cross products

A group of bins can be marked as illegal by specifying a select expression using **illegal_bins**. For example:

```
covergroup zz(int bad);  
  cross x, y  
  {  
    illegal_bins illegal = binsof(y) intersect {bad};  
  }  
endgroup
```

All cross products that satisfy the select expression are excluded from coverage, and a run-time error is issued. Illegal cross products take precedence over any other cross products, that is, they will result in a run-time error even if they are also explicitly ignored (using an **ignore_bins**) or included in another cross bin.

19.7 Specifying coverage options

Options control the behavior of the **covergroup**, **coverpoint**, and **cross**. There are two types of options: those that are specific to an instance of a covergroup and those that specify an option for the covergroup type as a whole.

Specifying a value for the same option more than once within the same **covergroup** definition shall be an error.

[Table 19-1](#) lists instance-specific covergroup options and their description. Each instance of a covergroup can initialize an instance-specific option to a different value. The initialized option value affects only that instance.

Table 19-1—Instance-specific coverage options

Option name	Default	Description
weight=number	1	If set at the covergroup syntactic level, it specifies the weight of this covergroup instance for computing the overall instance coverage of the simulation. If set at the coverpoint (or cross) syntactic level, it specifies the weight of a coverpoint (or cross) for computing the instance coverage of the enclosing covergroup . The specified weight shall be a non-negative integral value.
goal=number	100	Specifies the target goal for a covergroup instance or for a coverpoint or a cross of an instance.
name=string	unique name	Specifies a name for the covergroup instance. If unspecified, a unique name for each instance is automatically generated by the tool.
comment=string	""	A comment that appears with a covergroup instance or with a coverpoint or cross of the covergroup instance. The comment is saved in the coverage database and included in the coverage report.
at_least=number	1	Minimum number of hits for each bin. A bin with a hit count that is less than <i>number</i> is not considered covered.
detect_overlap=boolean	0	When true, a warning is issued if there is an overlap between the range list (or transition list) of two bins of a coverpoint.
auto_bin_max=number	64	Maximum number of automatically created bins when no bins are explicitly defined for a coverpoint.
cross_num_print_missing=number	0	Number of missing (not covered) cross product bins that shall be saved to the coverage database and printed in the coverage report.
per_instance=boolean	0	Each instance contributes to the overall coverage information for the covergroup type. When true, coverage information for this covergroup instance shall be saved in the coverage database and included in the coverage report. When false, implementations are not required to save instance-specific information.
get_inst_coverage=boolean	0	Only applies when the <code>merge_instances</code> type option is set. Enables the tracking of per instance coverage with the <code>get_inst_coverage</code> built-in method. When false, the value returned by <code>get_inst_coverage</code> shall equal the value returned by <code>get_coverage</code> .

The instance-specific options mentioned above can be set in the **covergroup** definition. The syntax for setting these options in the **covergroup** definition is as follows:

```
option.member_name = expression ;
```

The identifier **option** is a built-in member of every covergroup, coverpoint and cross (see [19.10](#) for a description).

For example:

```
covergroup g1 (int w, string instComment) @(posedge clk) ;
// track coverage information for each instance of g1 in addition
// to the cumulative coverage information for covergroup type g1
option.per_instance = 1;

// comment for each instance of this covergroup
option.comment = instComment;

a : coverpoint a_var
{
    // Create 128 automatic bins for coverpoint "a" of each instance of g1
    option.auto_bin_max = 128;
}
b : coverpoint b_var
{
    // This coverpoint contributes w times as much to the coverage of an
    // instance of g1 as coverpoints "a" and "c1"
    option.weight = w;
}
c1 : cross a_var, b_var ;
endgroup
```

Option assignment statements in the **covergroup** definition are evaluated at the time that the covergroup is instantiated. The **per_instance** and **get_inst_coverage** options can only be set in the **covergroup** definition. The **auto_bin_max** and **detect_overlap** options can only be set in the **covergroup** or **coverpoint** definition. Other instance-specific options can be assigned procedurally after a covergroup has been instantiated.

For example:

```
covergroup gc (int maxA, int maxB) @(posedge clk) ;
    a : coverpoint a_var;
    b : coverpoint b_var;
endgroup
...
gc g1 = new (10,20);
g1.option.comment = "Here is a comment set for the instance g1";
g1.a.option.weight = 3; // Set weight for coverpoint "a" of instance g1
```

[Table 19-2](#) summarizes the syntactical level (**covergroup**, **coverpoint**, or **cross**) at which instance options can be specified. All instance options can be specified at the covergroup level. Except for the **weight**, **goal**, **comment**, and **per_instance** options, all other options set at the covergroup syntactic level act as a default value for the corresponding option of all coverpoints and crosses in the covergroup. Individual coverpoints or crosses can overwrite these default values. When set at the covergroup level, the **weight**, **goal**, **comment**, and **per_instance** options do not act as default values to the lower syntactic levels.

Table 19-2—Coverage options per-syntactic level

Option name	Allowed in syntactic level		
	covergroup	coverpoint	cross
name	Yes	No	No
weight	Yes	Yes	Yes
goal	Yes	Yes	Yes
comment	Yes	Yes	Yes
at_least	Yes (default for coverpoints & crosses)	Yes	Yes
detect_overlap	Yes (default for coverpoints)	Yes	No
auto_bin_max	Yes (default for coverpoints)	Yes	No
cross_num_print_missing	Yes (default for crosses)	No	Yes
per_instance	Yes	No	No

19.7.1 Covergroup type options

[Table 19-3](#) lists options that describe particular features (or properties) of the **covergroup** type as a whole. They are analogous to static data members of classes.

Table 19-3—Coverage group type (static) options

Option name	Default	Description
weight = <i>constant_number</i>	1	If set at the covergroup syntactic level, it specifies the weight of this covergroup for computing the overall cumulative (or type) coverage of the saved database. If set at the coverpoint (or cross) syntactic level, it specifies the weight of a coverpoint (or cross) for computing the cumulative (or type) coverage of the enclosing covergroup . The specified weight shall be a non-negative integral value.
goal = <i>constant_number</i>	100	Specifies the target goal for a covergroup type or for a coverpoint or cross of a covergroup type.
comment = <i>string_literal</i>	""	A comment that appears with the covergroup type or with a coverpoint or cross of the covergroup type. The comment is saved in the coverage database and included in the coverage report.
strobe = <i>boolean</i>	0	When true, all samples happen at the end of the time slot, like the <code>\$strobe</code> system task.
merge_instances = <i>boolean</i>	0	When true, cumulative (or type) coverage is computed by merging instances together as the union of coverage of all instances. When false, type coverage is computed as the weighted average of instances.

The **covergroup** type options mentioned above can be set in the **covergroup** definition. The syntax for setting these options in the **covergroup** definition is as follows:

```
type_option.member_name = constant_expression ;
```

The identifier `type_option` is a built-in static member of every `covergroup`, `coverpoint` and `cross` (see [19.10](#) for a description).

Different instances of a `covergroup` cannot assign different values to type options. This is syntactically disallowed because these options can only be initialized via constant expressions (see [11.2.1](#)). For example:

```
covergroup g1 (int w, string instComment) @(posedge clk) ;
  // track coverage information for each instance of g1 in addition
  // to the cumulative coverage information for covergroup type g1
  option.per_instance = 1;

  type_option.comment = "Coverage model for features x and y";

  type_option.strobe = 1;    // sample at the end of the time slot

  // compute type coverage as the merge of all instances
  type_option.merge_instances = 1;

  // comment for each instance of this covergroup
  option.comment = instComment;

  a : coverpoint a_var
  {
    // Use weight 2 to compute the coverage of each instance
    option.weight = 2;
    // Use weight 3 to compute the cumulative (type) coverage for g1
    type_option.weight = 3;
    // NOTE: type_option.weight = w would cause syntax error.
  }
  b : coverpoint b_var
  {
    // Use weight w to compute the coverage of each instance
    option.weight = w;
    // Use weight 5 to compute the cumulative (type) coverage of g1
    type_option.weight = 5;
  }
endgroup
```

In the above example, the coverage for each instance of `g1` is computed as follows:

$$(((\text{instance coverage of a}) \times 2) + ((\text{instance coverage of b}) \times w)) / (2 + w)$$

On the other hand, the coverage for `covergroup` type `g1` is computed as follows:

$$(((\text{merge of coverage of a from all instances}) \times 3) + ((\text{merge of coverage of b from all instances}) \times 5)) / (3 + 5)$$

The `strobe` type option can only be set in the `covergroup` definition. Other type options can be assigned procedurally at any time during simulation.

For example:

```
covergroup gc @(posedge clk) ;
  a : coverpoint a_var;
  b : coverpoint b_var;
endgroup
...
// Set the comment for all covergroups of type "gc"
gc::type_option.comment = "Here is a comment for covergroup g1";
```

```
// Set the weight for coverpoint "a" of all covergroups of type gc
gc::a::type_option.weight = 3;
gc gl = new;
```

Table 19-4 summarizes the syntactical level (**covergroup**, **coverpoint**, or **cross**) in which type options can be specified. When set at the covergroup level, the type options do not act as defaults for lower syntactic levels.

Table 19-4—Coverage type options

Option name	Allowed syntactic level		
	covergroup	coverpoint	cross
weight	Yes	Yes	Yes
goal	Yes	Yes	Yes
comment	Yes	Yes	Yes
strobe	Yes	No	No

19.8 Predefined coverage methods

The coverage methods in Table 19-5 are provided for the covergroup. These methods can be invoked procedurally at any time.

Table 19-5—Predefined coverage methods

Method (function)	Can be called on			Description
	covergroup	coverpoint	cross	
void sample()	Yes	No	No	Triggers sampling of the covergroup
real get_coverage() real get_coverage(ref int, ref int)	Yes	Yes	Yes	Calculates type coverage number (0...100)
real get_inst_coverage() real get_inst_coverage(ref int, ref int)	Yes	Yes	Yes	Calculates the coverage number (0...100)
void set_inst_name(string)	Yes	No	No	Sets the instance name to the given string
void start()	Yes	Yes	Yes	Starts collecting coverage information
void stop()	Yes	Yes	Yes	Stops collecting coverage information

The `get_coverage()` method returns the cumulative (or type) coverage, which considers the contribution of all instances of a particular coverage item; and it is a static method that is available on both types (via the `::` operator) and instances (using the `.` operator). In contrast, the `get_inst_coverage()` method returns the coverage of the specific instance on which it is invoked; thus, it can only be invoked via the `.` operator.

The `get_coverage()` and `get_inst_coverage()` methods both accept an optional set of arguments, a pair of `int` values passed by reference. When the optional arguments are specified, the `get_coverage()` and `get_inst_coverage()` methods assign to the first argument the number of covered bins and to the second argument the number of coverage bins defined for the given coverage item. When `get_inst_coverage()` is called on a **coverpoint** or **cross**, these two values correspond to the numerator and the denominator used for calculating the particular coverage number (i.e., the return value before scaling by 100); in other cases, these two values do not necessarily correspond to the numerator and denominator. When `get_inst_coverage()` is called on a **covergroup**, these values are aggregated numbers of bins from all constituent coverpoints and crosses of the same instance. When `get_coverage()` is called on a **coverpoint** or **cross**, these values are aggregated numbers of bins from the same **coverpoint** or **cross** in all instances. When `get_coverage()` is called on a **covergroup**, these values are aggregated numbers of bins from all coverpoints and crosses in all instances.

For example:

```
covergroup cg (int xb, yb, ref int x, y) ;
  coverpoint x {bins xbins[] = { [0:xb] }; }
  coverpoint y {bins ybins[] = { [0:yb] }; }
endgroup
cg cv1 = new (1,2,a,b); // cv1.x has 2 bins, cv1.y has 3 bins
cg cv2 = new (3,6,c,d); // cv2.x has 4 bins, cv2.y has 7 bins

initial begin
  cv1.x.get_inst_coverage(covered,total); // total = 2
  cv1.get_inst_coverage(covered,total); // total = 5
  cg::x::get_coverage(covered,total); // total = 6
  cg::get_coverage(covered,total); // total = 16
end
```

19.8.1 Overriding the built-in sample method

Overriding the pre-defined `sample()` method with a triggering function that accepts arguments facilitates sampling coverage data from contexts other than the scope enclosing the covergroup declaration. For example, an overridden sample method can be called with different arguments to pass directly to a covergroup the data to be sampled from within an automatic task or function, or from within a particular instance of a process, or from within a sequence or property of a concurrent assertion. Since concurrent assertions have special sampling semantics (values are sampled in the Preponed region), passing their values as arguments to an overridden sample method facilitates managing various aspects of assertion coverage, such as sampling of multiple covergroups by one property, sampling of multiple properties by the same covergroup, or sampling different branches of a sequence or property (including local variables) by any arbitrary covergroup.

For example:

```
covergroup p_cg with function sample(bit a, int x);
  coverpoint x;
  cross x, a;
endgroup : p_cg

p_cg cg1 = new;

property p1;
  int x;
  @(posedge clk) (a, x = b) ##1 (c, cg1.sample(a, x));
endproperty : p1
```

```

c1: cover property (p1);

function automatic void F(int j);
    bit d;
    ...
    cg1.sample( d, j );
endfunction

```

The example above declares covergroup `p_cg` whose sample method is overridden to accept two arguments: `a` and `x`. The sample method of an instance of this covergroup (`cg1`) is then called directly from within property `p1` and from the automatic function `F()`.

The formal arguments of an overridden sample method shall be searched before the enclosing scope; each such argument may only designate a coverpoint or conditional guard expression. It shall be an error to use a sample formal argument in any context other than a coverpoint or conditional guard expression. Formal sample arguments shall not designate an output direction. The formal arguments of an overridden sample method belong to the same lexical scope as the formal arguments to the covergroup (consumed by the covergroup new operator). Hence, it shall be an error for the same argument name to be specified in both argument lists.

For example:

```

covergroup C1 (int v) with function sample (int v, bit b); // error (v)
    coverpoint v;
    option.per_instance = b; // error: b may only designate a coverpoint
    option.weight = v;      // error: v is ambiguous
endgroup

```

19.9 Predefined coverage system tasks and system functions

SystemVerilog provides the following system tasks and system functions to help manage coverage data collection.

- `$set_coverage_db_name (filename)` sets the filename of the coverage database into which coverage information is saved at the end of a simulation run.
- `$load_coverage_db (filename)` loads from the given filename the cumulative coverage information for all coverage group types.
- `$get_coverage ()` returns as a real number in the range of 0 to 100 the overall coverage of all coverage group types. This number is computed as described above.

19.10 Organization of option and type_option members

The `option` and `type_option` members of a covergroup, coverpoint, and cross are implicitly declared structures with the following composition:

```

struct          // covergroup option declaration
{
    string name ;
    int weight ;
    int goal ;
    string comment ;
    int at_least ;
    int auto_bin_max ;
    int cross_num_print_missing ;
    bit detect_overlap ;
}

```

```
    bit    per_instance ;
    bit    get_inst_coverage ;
} option;

struct    // coverpoint option declaration
{
    int    weight ;
    int    goal ;
    string comment ;
    int    at_least ;
    int    auto_bin_max ;
    bit    detect_overlap ;
} option;

struct    // cross option declaration
{
    int    weight ;
    int    goal ;
    string comment ;
    int    at_least ;
    int    cross_num_print_missing ;
} option;

struct    // covergroup type_option declaration
{
    int    weight ;
    int    goal ;
    string comment ;
    bit    strobe ;
    bit    merge_instances ;
} type_option;

struct    // coverpoint and cross type_option declaration
{
    int    weight ;
    int    goal ;
    string comment ;
} type_option;
```

19.11 Coverage computation

This subclause describes how SystemVerilog computes functional coverage numbers. The cumulative (or type) coverage considers the contribution of all instances of a particular coverage item, and it is the value returned by the `get_coverage()` method. Thus, when applied to a covergroup, the `get_coverage()` method returns the contribution of all instances of that particular covergroup. In contrast, the `get_inst_coverage()` method returns the coverage of the specific coverage instance on which it is invoked. Because `get_coverage()` is a static method, it is available for both types (via the `::` operator) and instances (using the `.` operator). There are two different ways in which type coverage can be computed, selected with `type_option.merge_instances`. See [19.11.3](#).

The coverage of a coverage group, C_g , is the weighted average of the coverage of all items defined in the coverage group, and it is computed according to the following equation:

$$C_g = \frac{\sum_i W_i \times C_i}{\sum_i W_i}$$

where

- i ∈ set of coverage items (coverage points and crosses) defined in the coverage group
- W_i is the weight associated with item i
- C_i is the coverage of item i

The coverage of each item, C_i , is a measure of how much the item has been covered, and its computation depends on the type of coverage item: **coverpoint** or **cross**. Each of these is described in [19.11.1](#) and [19.11.2](#), respectively.

The rules for computation of the coverage C_i of an item may indicate that the item is to be excluded from the coverage computation. In this case, the contribution of the item is excluded from both the numerator and the denominator.

There are several circumstances that can result in the denominator of the covergroup calculation equation being zero:

- All items in a covergroup are excluded from coverage due to the rules for computation of C_i
- All weights W_i are zero
- A covergroup contains no coverpoints or crosses

Any zero denominator in the coverage calculation shall result in the following:

- a) The covergroup does not contribute to the overall coverage score.
- b) If the covergroup’s weight is non-zero, a value of 0.0 is returned by `get_coverage` and `get_inst_coverage`.
- c) If the covergroup’s weight is zero, a value of 100.0 is returned by `get_coverage` and `get_inst_coverage`.
- d) If `get_coverage` or `get_inst_coverage` is called with two arguments, zero is assigned to both arguments—the numerator and denominator.

Consistent with the above behavior, `$get_coverage` shall return a value of 100.0 if called on a design that has no covergroup instances, or if called on a design in which all covergroups have a weight of 0.

19.11.1 Coverpoint coverage computation

Coverage of a coverpoint item is computed differently depending on whether the bins of the coverage point are explicitly defined by the user (see [19.5.1](#)) or automatically created by the tool (see [19.5.2](#)). For user-defined bins, the coverage of a coverpoint is computed as follows:

$$C_i = \frac{|bins_{covered}|}{|bins|}$$

where

- $|bins|$ is the cardinality of the set of bins defined
- $|bins_{covered}|$ is the cardinality of the covered bins—the subset of all (defined) bins that are covered

For automatically generated bins, the coverage of a coverpoint is computed as follows:

$$C_i = \frac{|bins_{covered}|}{\text{MIN}(\text{auto_bin_max}, 2^M)}$$

where

- $|bins_{covered}|$ is the cardinality of the covered bins—the subset of all (auto-defined) bins that are covered
- M is the minimum number of bits needed to represent the coverpoint
- `auto_bin_max` is the value of the `auto_bin_max` option in effect (see [19.7](#))

If there is no value or transition associated with a bin, the bin is ignored and shall not contribute to the coverage computation. That is, the bin is excluded from both the numerator and the denominator of the coverage equation.

If none of the bins have an associated value or transition, the denominator of the coverage calculation is zero. In this case:

- a) The coverpoint does not contribute to the coverage computation (of the parent covergroup).
- b) If the coverpoint's weight is non-zero, a value of 0.0 is returned by `get_coverage` and `get_inst_coverage`.
- c) If the coverpoint's weight is zero, a value of 100.0 is returned by `get_coverage` and `get_inst_coverage`.
- d) If `get_coverage` or `get_inst_coverage` is called with two arguments, zero is assigned to both arguments—the numerator and denominator.

For example:

```

bit [2:0] a, b;
covergroup ct;
  coverpoint b {
    option.auto_bin_max = 4;
    ignore_bins ig = { [0:1], [5:6] };
  }
endgroup

```

In this case, coverpoint `b` will have 4 auto bins: `auto[0,1]`, `auto[2,3]`, `auto[4,5]`, `auto[6,7]`. The `ignore_bins` declaration specifies that the values 0,1,5,6 are ignored. After applying the `ignore_bins`, the bins are: `auto[]`, `auto[2,3]`, `auto[4]`, `auto[7]`. Since it no longer is associated with any value, `auto[]` does not contribute to coverage.

To determine whether a particular bin of a coverage group is covered, the cumulative coverage computation considers the value of the `at_least` option of all instances being accumulated. Consequently, a bin is not considered covered unless its hit count equals or exceeds the maximum of all the `at_least` values of all instances. Use of the maximum represents the more conservative choice.

19.11.2 Cross coverage computation

The coverage of a **cross** item is computed according to the following equation:

$$C_i = \frac{|bins_{covered}|}{B_c + B_u}$$

$$B_c = \left(\prod_j B_j \right) - B_b$$

where

- j ∈ set of coverpoints being crossed
- B_j is the cardinality (number of bins) of the j^{th} coverpoint being crossed
- B_c is the number of auto-cross bins
- B_u is the number of significant user-defined cross bins—excluding `ignore_bins` and `illegal_bins`
- B_b is the number of cross products that comprise all user-defined cross bins

The term B_u represents user-defined bins that contribute towards coverage.

If the denominator of the cross coverage calculation equation has a value of zero:

- a) The cross does not contribute to the coverage computation (of the parent covergroup).
- b) If the cross's weight is non-zero, a value of 0.0 is returned by `get_coverage` and `get_inst_coverage`.
- c) If the cross's weight is zero, a value of 100.0 is returned by `get_coverage` and `get_inst_coverage`.
- d) If `get_coverage` or `get_inst_coverage` is called with two arguments, zero is assigned to both arguments—the numerator and denominator.

19.11.3 Type coverage computation

Cumulative (or type) coverage is computed in two ways. When `type_option.merge_instances` is false, type coverage is computed as the weighted average of all instances. When `type_option.merge_instances` is true, type coverage is computed as if instances were merged together into the type, as a union of coverage of all instances.

When type coverage is computed as the weighted average of all instances, the covergroup type coverage depends on the instances only, not its coverpoints or crosses:

$$\frac{\sum W_i \times I_i}{\sum W_i}$$

where

- W_i is the option.weight of a covergroup instance
- I_i is the coverage of a covergroup instance

Likewise, the type coverage of a coverpoint or cross is computed from the coverage of that coverpoint or cross in each instance, weighted by `option.weight` in the coverpoint or cross scope for each instance.

The values returned by `get_coverage(ref int, ref int)` are consistent with the weighted sum above when `type_option.merge_instances` is false.

When type coverage is computed as the merge of coverage from all instances, the union of all bins from all instances must be computed. To determine when bins overlap among instances, the bin name is used as described in detail below. When bins overlap among instances, the cumulative coverage count of an overlapping bin is the sum of counts of that bin in all instances containing it. For example:

```

covergroup gt ( int l, h);
  coverpoint a { bins b[] = { [l:h] }; }
endgroup
gt gv1 = new (0,1);
gt gv2 = new (1,2);

```

In this case, bin “b[1]” overlaps between instances referenced by *gv1* and *gv2*. The covergroup *gt* has bins “b[0]”, “b[1]”, and “b[2]”. If *a==0* were sampled by *gv1* and *a==1* sampled by both *gv1* and *gv2*, the *gt::get_coverage()* value would be 66.6667 because 2 out of 3 type bins were covered; the cumulative count for the bin “b[1]” would be 2. If instance coverage were enabled with *option.get_inst_coverage* equal to 1 for both instances, *gv1.get_inst_coverage()* would return 100.0 and *gv2.get_inst_coverage()* would return 50.0.

To compute the union of all bins in all instances, bins are compared by name, so that bins with the same name are overlapping among instances. For state or transition bins declared as “binname”, all instances share the same name, so the bin overlaps in all instances. For state bins declared as “binname[]”, bin names are “binname[*value*]” (as specified in 19.5) for a set of scalar *values*. Instances sharing the same value have overlapping bins. For state bins declared as “binname[*N*]”, bin names range “binname[0]” through “binname[*N-1*]”. Instances sharing the same indices have overlapping bins. For automatically created bins, bin names are of the form “auto[*value*]” or “auto[*low:high*]” (as specified in 19.5.2), and these names are unaffected by ignored or illegal values in the coverpoint except inasmuch as they may empty an automatically created bin. Instances sharing the same value or low:high range have overlapping bins. For transition bins declared as “binname[]”, bin names are “binname[*transition*]” for some bounded transition (as specified in 19.5.1). Instances sharing the same transition have overlapping bins. For automatically created cross bins, bin names are of the form “<binname1,...,binnameN>” where the bin names are derived from the crossed coverpoint bins (as specified in 19.6). Instances sharing exactly the same cross product bin name have overlapping bins.

The following example shows automatically created bins:

```

bit [7:0] a;
covergroup ga ( int abm);
  option.auto_bin_max = abm;
  coverpoint a { ignore_bins i = {3}; }
endgroup
ga gv1 = new (64);
ga gv2 = new (32);

```

In this case, the bins of the instance referenced by *gv1* are “auto[0:3]” through “auto[252:255],” while the bins of the instance referenced by *gv2* are “auto[0:7]” through “auto[248:255].” Note how the ignored value 3 does not have an effect on the bin names. Because none of the bin names overlap between the two instances, the covergroup type *ga* has 96 cumulative bins.

20. Utility system tasks and system functions

20.1 General

This clause describes the utility system tasks and system functions that are part of SystemVerilog. [Clause 21](#) presents additional system tasks and system functions that are specific to I/O operations. The system tasks and system functions described in this clause are divided into several categories, as follows:

Simulation control tasks ([20.2](#))

\$finish \$stop
\$exit

Simulation time functions ([20.3](#))

\$realtime \$stime
\$time

Timescale tasks ([20.4](#))

\$sprinttimescale \$timeformat

Conversion functions ([20.5](#))

\$bitstoreal \$realtobits
\$bitstoshortreal \$shortrealtobits
\$itor \$rtoi
\$signed \$unsigned
\$cast

Data query functions ([20.6](#))

\$bits \$isunbounded
\$typename

Array query functions ([20.7](#))

\$unpacked_dimensions \$dimensions
\$left \$right
\$low \$high
\$increment \$size

Math functions ([20.8](#))

\$clog2 \$asin
\$ln \$acos
\$log10 \$atan
\$exp \$atan2
\$sqrt \$hypot
\$pow \$sinh
\$floor \$cosh
\$ceil \$tanh
\$sin \$asinh
\$cos \$acosh
\$tan \$atanh

Severity tasks ([20.9](#))

\$fatal \$error
\$warning \$info

Elaboration tasks ([20.10](#))

\$fatal \$error
\$warning \$info

Assertion control tasks ([20.11](#))

\$asserton \$assertoff
\$assertkill

Assertion action control tasks ([20.12](#))

\$assertpasson \$assertpassoff
\$assertfailon \$assertfailoff
\$assertnonvacuouson
\$assertvacuousoff

Assertion functions ([20.13](#))

\$onehot \$onehot0
\$isunknown \$sampled
\$rose \$fell
\$stable \$changed
\$past \$countones
\$past_gclk \$rose_gclk
\$fell_gclk \$stable_gclk
\$changed_gclk \$future_gclk
\$rising_gclk \$falling_gclk
\$steady_gclk \$changing_gclk

Coverage control functions ([20.14](#))

\$coverage_control \$coverage_get_max
\$coverage_get \$coverage_merge
\$coverage_save \$get_coverage
\$set_coverage_db_name \$load_coverage_db

Probabilistic distribution functions ([20.15](#))

\$random \$dist_chi_square
\$dist_erlang \$dist_exponential
\$dist_normal \$dist_poisson
\$dist_t \$dist_uniform

Stochastic analysis tasks and functions ([20.16](#))

\$q_initialize \$q_add
\$q_remove \$q_full
\$q_exam

PLA modeling tasks ([20.17](#))

\$async\$and\$array \$async\$and\$plane
\$async\$nand\$array \$async\$nand\$plane
\$async\$or\$array \$async\$or\$plane
\$async\$nor\$array \$async\$nor\$plane
\$sync\$and\$array \$sync\$and\$plane
\$sync\$nand\$array \$sync\$nand\$plane
\$sync\$or\$array \$sync\$or\$plane
\$sync\$nor\$array \$sync\$nor\$plane

Miscellaneous tasks and functions ([20.18](#))

\$system

20.2 Simulation control system tasks

This subclause defines the following three simulation control system tasks:

- a) `$finish`
- b) `$stop`
- c) `$exit`

```
simulation_control_task ::=
  $stop [ ( n ) ] ;
  $finish [ ( n ) ] ;
  $exit [ ( ) ] ;
```

Syntax 20-1—Syntax for simulation control tasks (not in [Annex A](#))

The `$stop` system task causes simulation to be suspended.

The `$finish` system task causes the simulator to exit and pass control back to the host operating system.

The `$exit` control task waits for all **program** blocks to complete, and then makes an implicit call to `$finish`. The usage of `$exit` is presented in [24.7](#) on program blocks.

The `$stop` and `$finish` system tasks take an optional expression argument (0, 1, or 2) that determines what type of diagnostic message is printed, as shown in [Table 20-1](#). If no argument is supplied, then a value of 1 is taken as the default.

Table 20-1—Diagnostics for `$finish`

Argument value	Diagnostic message
0	Prints nothing
1	Prints simulation time and location
2	Prints simulation time, location, and statistics about the memory and central processing unit (CPU) time used in simulation

20.3 Simulation time system functions

The following system functions provide access to current simulation time:

`$time` `$stime` `$realtime`

The syntax for time system functions is shown in [Syntax 20-2](#).

```
time_function ::=
  $time
  | $stime
  | $realtime
```

Syntax 20-2—Syntax for time system functions (not in [Annex A](#))

20.3.1 \$time

The `$time` system function returns an integer that is a 64-bit time, scaled to the time unit of the module that invoked it.

For example:

```
`timescale 10 ns / 1 ns
module test;
  logic set;
  parameter p = 1.55;
  initial begin
    $monitor($time, "set=", set);
    #p set = 0;
    #p set = 1;
  end
endmodule
```

The output from this example is as follows:

```
0 set=x
2 set=0
3 set=1
```

In this example, the variable `set` is assigned the value 0 at simulation time 16 ns, and the value 1 at simulation time 32 ns. The time values returned by the `$time` system function are determined by the following steps:

- The simulation times 16 ns and 32 ns are scaled to 1.6 and 3.2 because the time unit for the module is 10 ns; therefore, time values reported by this module are multiples of 10 ns.
- The value 1.6 is rounded to 2, and 3.2 is rounded to 3 because the `$time` system function returns an integer. The time precision does not cause rounding of these values.

NOTE—The times at which the assignments take place in this example do not match the times reported by `$time`.

20.3.2 \$stime

The `$stime` system function returns an unsigned integer that is a 32-bit time, scaled to the time unit of the module that invoked it. If the actual simulation time does not fit in 32 bits, the low order 32 bits of the current simulation time are returned.

20.3.3 \$realtime

The `$realtime` system function returns a real number time that, like `$time`, is scaled to the time unit of the module that invoked it.

For example:

```
`timescale 10 ns / 1 ns
module test;
  logic set;
  parameter p = 1.55;
  initial begin
    $monitor($realtime, "set=", set);
    #p set = 0;
    #p set = 1;
  end
endmodule
```

The output from this example is as follows:

```
0 set=x
1.6 set=0
3.2 set=1
```

In this example, the event times in the variable `set` are multiples of 10 ns because 10 ns is the time unit of the module. They are real numbers because `$realtime` returns a real number.

20.4 Timescale system tasks

This subclause defines the system tasks that display and set timescale printing information:

- a) `$printtimescale`
- b) `$timeformat`

See [22.7](#) for a discussion of timescale and time units.

20.4.1 `$printtimescale`

The `$printtimescale` system task displays the time unit and precision for a particular module. The syntax for the system task is shown in [Syntax 20-3](#).

```
printtimescale_task ::=
    $printtimescale [ ( hierarchical_identifier ) ] ;
```

Syntax 20-3—Syntax for `$printtimescale` (not in [Annex A](#))

This system task can be specified with or without an argument.

- When no argument is specified, `$printtimescale` displays the time unit and precision of the module that is the current scope.
- When an argument is specified, `$printtimescale` displays the time unit and precision of the module passed to it.

The timescale information shall appear in the following format:

```
Time scale of (module_name) is unit / precision
```

For example:

```
`timescale 1 ms / 1 us
module a_dat;
    initial
        $printtimescale(b_dat.c1);
endmodule

`timescale 10 fs / 1 fs
module b_dat;
    c_dat c1 ();
endmodule

`timescale 1 ns / 1 ns
module c_dat;
```

```

        .
        .
        .
    endmodule

```

In this example, module `a_dat` invokes the `$printtimescale` system task to display timescale information about another module `c_dat`, which is instantiated in module `b_dat`.

The information about `c_dat` shall be displayed in the following format:

```

    Time scale of (b_dat.c1) is 1ns / 1ns

```

20.4.2 \$timeformat

The syntax for the `$timeformat` system task is shown in [Syntax 20-4](#).

```

timeformat_task ::=
    $timeformat [ ( units_number , precision_number , suffix_string , minimum_field_width ) ] ;

```

Syntax 20-4—Syntax for \$timeformat (not in Annex A)

The `$timeformat` system task performs the following two functions:

- It specifies how the `%t` format specification reports time information for the `$write`, `$display`, `$strobe`, `$monitor`, `$fwrite`, `$fdisplay`, `$fstrobe`, and `$fmonitor` group of system tasks.
- It specifies the time unit for delays entered interactively.

The units number argument shall be an integer in the range from 0 to -15. This argument represents the time unit as shown in [Table 20-2](#).

Table 20-2—\$timeformat units_number arguments

Unit number	Time unit	Unit number	Time unit
0	1 s	-8	10 ns
-1	100 ms	-9	1 ns
-2	10 ms	-10	100 ps
-3	1 ms	-11	10 ps
-4	100 us	-12	1 ps
-5	10 us	-13	100 fs
-6	1 us	-14	10 fs
-7	100 ns	-15	1 fs

NOTE—While s, ms, ns, ps, and fs are the usual SI unit symbols for second, millisecond, nanosecond, picosecond, and femtosecond, due to lack of the Greek letter μ (mu) in coding character sets, 'us' represents the SI unit symbol for microsecond, properly μ s.

The `$timeformat` system task performs the following two operations:

- It sets the time unit for all later-entered delays entered interactively.

- It sets the time unit, precision number, suffix string, and minimum field width for all %t formats specified in all modules that follow in the source description until another \$timeformat system task is invoked.

The default \$timeformat system task arguments are given in [Table 20-3](#).

Table 20-3—\$timeformat default value for arguments

Argument	Default
units_number	The smallest time precision argument of all the `timescale compiler directives in the source description
precision_number	0
suffix_string	A null character string
minimum_field_width	20

The following example shows the use of %t with the \$timeformat system task to specify a uniform time unit, time precision, and format for timing information.

```

`timescale 1 ms / 1 ns
module cntrl;
  initial
    $timeformat(-9, 5, " ns", 10);
endmodule

`timescale 1 fs / 1 fs
module a1_dat;
  logic in1;
  integer file;
  buf #10000000 (o1,in1);
  initial begin
    file = $fopen("a1.dat");
    #00000000 $fmonitor(file,"%m: %t in1=%d o1=%h", $realtime,in1,o1);
    #10000000 in1 = 0;
    #10000000 in1 = 1;
  end
endmodule

`timescale 1 ps / 1 ps
module a2_dat;
  logic in2;
  integer file2;
  buf #10000 (o2,in2);
  initial begin
    file2=$fopen("a2.dat");
    #00000 $fmonitor(file2,"%m: %t in2=%d o2=%h", $realtime,in2,o2);
    #10000 in2 = 0;
    #10000 in2 = 1;
  end
endmodule

```

The contents of file a1.dat are as follows:

```

a1_dat: 0.00000 ns in1= x o1=x
a1_dat: 10.00000 ns in1= 0 o1=x

```

```
a1_dat: 20.00000 ns in1= 1 o1=0
a1_dat: 30.00000 ns in1= 1 o1=1
```

The contents of file `a2.dat` are as follows:

```
a2_dat: 0.00000 ns in2=x o2=x
a2_dat: 10.00000 ns in2=0 o2=x
a2_dat: 20.00000 ns in2=1 o2=0
a2_dat: 30.00000 ns in2=1 o2=1
```

In this example, the times of events written to the files by the `$fmonitor` system task in modules `a1_dat` and `a2_dat` are reported as multiples of 1 ns—even though the time units for these modules are 1 fs and 1 ps, respectively—because the first argument of the `$timeformat` system task is `-9` and the `%t` format specification is included in the arguments to `$fmonitor`. This time information is reported after the module names with five fractional digits, followed by an `ns` character string in a space wide enough for 10 ASCII characters.

20.5 Conversion functions

System functions are provided to convert values to and from real number values, and to convert values to signed or unsigned values.

The following system functions handle real number values (the `real` and `shortreal` types).

```
integer      $rtoi ( real_val )
real        $itor ( int_val )

[63:0]      $realtobits ( real_val )
real      $bitstoreal ( bit_val )

[31:0]      $shortrealtobits ( shortreal_val )
shortreal $bitstoshortreal ( bit_val )
```

These conversion system functions may be used in constant expressions, as specified in [11.2.1](#).

`$rtoi` converts real values to an `integer` type by truncating the real value (for example, 123.45 becomes 123). `$rtoi` differs from casting a real value to an `integer` or other integral type in that casting will perform rounding instead of truncation. Directly assigning a real value to an integral type will also round instead of truncate.

`$itor` converts integer values to real values (for example, 123 becomes 123.0).

`$realtobits` converts values from a `real` type to a 64-bit vector representation of the real number.

`$bitstoreal` converts a bit pattern created by `$realtobits` to a value of the `real` type.

`$shortrealtobits` converts values from a `shortreal` type to the 32-bit vector representation of the real number.

`$bitstoshortreal` converts a bit pattern created by `$shortrealtobits` to a value of the `shortreal` type.

NOTE—The real numbers accepted or generated by these functions shall conform to the *IEEE 754* representation of the single precision and double precision floating point numbers. The conversion shall round the result to the nearest valid representation.

The following example shows how the `$realtobits` and `$bitstoreal` functions can be used in port connections:

```

module driver (net_r);
  output [64:1] net_r;
  real r;
  wire [64:1] net_r = $realtobits(r);
endmodule

module receiver (net_r);
  input [64:1] net_r;
  wire [64:1] net_r;
  real r;
  initial assign r = $bitstoreal(net_r);
endmodule

```

NOTE—SystemVerilog allows directly passing real values across module, interface and program ports; it is not necessary to use the `$realtobits` and `$bitstoreal` conversion functions as shown in this example. IEEE Std 1364-2005 did not allow directly passing real values across module ports, and therefore utilized these system functions.

The `$signed` and `$unsigned` system functions can be used to cast the signedness (but not the type) of expressions. These functions shall evaluate the input expression and return a value with the same size and value of the input expression and the type defined by the function.

- `$signed` — returned value is signed
- `$unsigned` — returned value is unsigned

See [11.7](#) for examples of using `$signed` and `$unsigned`. The cast operator can also be used to change the signedness of an expression (see [6.24.1](#)).

The `$cast` system function performs a dynamic cast of an expression type. `$cast` is described in [6.24.2](#) and [8.15](#).

20.6 Data query functions

SystemVerilog provides system functions to query information about expressions, `$typename`, `$bits`, and `$isunbounded`.

20.6.1 Type name function

The `$typename` system function returns a string that represents the resolved type of its argument.

```

typename_function ::=
  $typename ( expression )
  | $typename ( data_type )

```

Syntax 20-5—Type name function syntax (not in [Annex A](#))

The return string is constructed in the following steps:

- a) A **typedef** that creates an equivalent type is resolved back to built-in or user-defined types.
- b) The default signing is removed, even if present explicitly in the source.
- c) System-generated names are created for anonymous structs, unions, and enums.
- d) A '\$' is used as the placeholder for the name of an anonymous unpacked array.
- e) Actual encoded values are appended with enumeration named constants.

- f) User-defined type names are prefixed with their defining package or scope name space.
- g) Array ranges are represented as unsized decimal numbers.
- h) White space in the source is removed and a single space is added to separate identifiers and key-words from each other.

This process is similar to the way that type matching (see [6.22.1](#)) is computed, except that simple bit vector types with predefined widths are distinguished from those with user-defined widths. Thus `$typename` can be used in string comparisons for stricter type comparison of arrays than with type references.

When called with an expression as its argument, `$typename` returns a string that represents the self-determined type result of the expression. The expression's return type is determined during elaboration, but never evaluated. When used as an elaboration time constant, the expression shall not contain any hierarchical references or references to elements of dynamic objects.

```

// source code                // $typename would return
typedef bit node;             // "bit"
node [2:0] X;                 // "bit [2:0]"
int signed Y;                // "int"
package A;
    enum {A,B,C=99} X;        // "enum{A=32'sd0,B=32'sd1,C=32'sd99}A::e$1"
    typedef bit [9:1'b1] word; // "A::bit[9:1]"
endpackage : A
import A::*;
module top;
    typedef struct {node A,B;} AB_t;
    AB_t AB[10];              // "struct{bit A;bit B;}top.AB_t$[0:9]"
    ...
endmodule

```

20.6.2 Expression size system function

The `$bits` system function returns the number of bits required to hold an expression as a bit stream. The return type is **integer**. See [6.24.3](#) for a definition of legal types. A 4-state value counts as 1 bit.

```

size_function ::=
    $bits ( expression )
  | $bits ( data_type )

```

Syntax 20-6—Size function syntax (not in [Annex A](#))

Given the declaration

```
logic [31:0] v;
```

then `$bits(v)` shall return 32, even if the implementation uses more than 32 bits of storage to represent the 4-state values. Given the declaration:

```

typedef struct {
    logic valid;
    bit [8:1] data;
} MyType;

```

the expression `$bits(MyType)` shall return 9, the number of data bits needed by a variable of type `MyType`.

The `$bits` function can be used as an elaboration time constant when used on fixed-size data types; hence, it can be used in the declaration of other data types, variables, or nets.

```
typedef bit[$bits(MyType):1] MyBits; //same as typedef bit [9:1] MyBits;
MyBits b;
```

Variable `b` can be used to hold the bit pattern of a variable of type `MyType` without loss of information.

The value returned by `$bits` shall be determined without actual evaluation of the expression it encloses. It shall be an error to enclose a function that returns a dynamically sized data type. The `$bits` return value shall be valid at elaboration only if the expression contains fixed-size data types.

The `$bits` system function returns 0 when called with a dynamically sized expression that is currently empty. It shall be an error to use the `$bits` system function directly with a dynamically sized data type identifier.

20.6.3 Range system function

The `$isunbounded` system function returns true if the argument is `$`.

```
range_function ::=
  $isunbounded ( constant_expression )
```

Syntax 20-7—Range function syntax (not in [Annex A](#))

Given the declaration

```
parameter int i = $;
```

then `$isunbounded(i)` shall return true. Otherwise, it shall return false. True and false are defined in [20.13](#).

20.7 Array querying functions

```
array_query_function ::=
  array_dimension_function ( array_identifier [ , dimension_expression ] )
  | array_dimension_function ( data_type [ , dimension_expression ] )
  | array_dimensions_function ( array_identifier )
  | array_dimensions_function ( data_type )
```

```
array_dimensions_function ::=
  $dimensions
  | $unpacked_dimensions
```

```
array_dimension_function ::=
  $left
  | $right
  | $low
  | $high
  | $increment
  | $size
```

```
dimension_expression ::= expression
```

Syntax 20-8—Array querying function syntax (not in [Annex A](#))

SystemVerilog provides system functions to return information about a particular dimension of an array (see [Clause 7](#)) or integral (see [6.11.1](#)) data type or of data objects of such a data type.

The return type is **integer**, and the default for the optional dimension expression is 1. The dimension expression can specify any fixed-size dimension (packed or unpacked) or any dynamically sized dimension (dynamic, associative, or queue). When used on a dynamic array or queue dimension, these functions return information about the current state of the array. For any dimension other than an associative array dimension:

- `$left` shall return the left bound of the dimension. For a packed dimension, this is the index of the most significant element. For a queue or dynamic array dimension, `$left` shall return 0.
- `$right` shall return the right bound of the dimension. For a packed dimension, this is the index of the least significant element. For a queue or dynamic array dimension whose current size is zero, `$right` shall return `-1`.
- For a fixed-size dimension, `$increment` shall return 1 if `$left` is greater than or equal to `$right` and `-1` if `$left` is less than `$right`. For a queue or dynamic array dimension, `$increment` shall return `-1`.
- `$low` shall return the same value as `$left` if `$increment` returns `-1`, and the same value as `$right` if `$increment` returns 1.
- `$high` shall return the same value as `$right` if `$increment` returns `-1`, and the same value as `$left` if `$increment` returns 1.
- `$size` shall return the number of elements in the dimension, which is equivalent to `$high - $low + 1`.
- `$dimensions` shall return the following:
 - The total number of dimensions in the array (packed and unpacked, static or dynamic)
 - 1 for the **string** data type or any other nonarray type that is equivalent to a simple bit vector type (see [6.11.1](#))
 - 0 for any other type
- `$unpacked_dimensions` shall return the following:
 - The total number of unpacked dimensions for an array (static or dynamic)
 - 0 for any other type

The dimensions of an array shall be numbered as follows: The slowest varying dimension (packed or unpacked) is dimension 1. Successively faster varying dimensions have sequentially higher dimension numbers. Intermediate type definitions are expanded first before numbering the dimensions.

For example:

```
//      Dimension numbers
//      3      4      1      2
logic [3:0][2:1] n [1:5][2:8];
typedef logic [3:0][2:1] packed_reg;
packed_reg n[1:5][2:8]; // same dimensions as in the lines above
```

For a fixed-size integer type (**integer**, **shortint**, **longint**, and **byte**), dimension 1 is predefined. For an integer *N* declared without a range specifier, its bounds are assumed to be [`$bits(N) - 1:0`].

If the first argument to an array query function would cause `$dimensions` to return 0 or if the second argument is out of range, then `'x` shall be returned.

It is an error to use these functions directly on a dynamically sized type identifier.

Use on associative array dimensions is restricted to index types with integral values. With integral indices, these functions shall return the following:

- `$left` shall return 0.
- `$right` shall return the highest possible index value.
- `$low` shall return the lowest currently allocated index value, but shall return 'x' if there are no elements currently allocated.
- `$high` shall return the largest currently allocated index value, but shall return 'x' if there are no elements currently allocated.
- `$increment` shall return -1.
- `$size` shall return the number of elements currently allocated.

It shall be legal to call any of these query functions within a constant expression if all three of the following conditions are true: (1) the call would be legal in an expression, (2) the first argument is a fixed-size type or is an expression of some fixed-size type, and (3) any optional dimension expression is a constant expression.

Given the declaration

```
typedef logic [16:1] Word;
Word Ram[0:9];
```

the following system functions return 16:

```
$size(Word)
(Ram,2)
```

20.7.1 Queries over multiple variable dimensions

If any of the functions described in [20.7](#) is called with arguments (*v*, *n*) where *v* denotes some array variable and *n* is greater than 1, then it shall be an error if the dimension indicated by *n* is a variable-sized dimension. The examples below illustrate this restriction. This restriction does not affect the `$dimensions` or `$unpacked_dimensions` functions, since they cannot accept a second argument.

```
int a[3][][5]; // array dimension 2 has variable size
$display( $unpacked_dimensions(a) ); // displays 3
a[2] = new[4];
a[2][2][0] = 220; // OK, a[2][2] is a 5-element array
$display( $size(a, 1) ); // OK, displays 3
$display( $size(a, 2) ); // ERROR, dimension 2 is dynamic
$display( $size(a[2], 1) ); // OK, displays 4 (a[2] is
// a 4-element dynamic array)
$display( $size(a[1], 1) ); // OK, displays 0 (a[1] is
// an empty dynamic array)
$display( $size(a, 3) ); // OK, displays 5 (fixed-size dimension)
```

20.8 Math functions

There are integer and real math functions. The math system functions may be used in constant expressions, as specified in [11.2.1](#).

20.8.1 Integer math functions

The system function `$clog2` shall return the ceiling of the log base 2 of the argument (the log rounded up to an integer value). The argument can be an integer or an arbitrary sized vector value. The argument shall be treated as an unsigned value, and an argument value of 0 shall produce a result of 0.

This system function can be used to compute the minimum address width necessary to address a memory of a given size or the minimum vector width necessary to represent a given number of states.

For example:

```
integer result;
result = $clog2(n);
```

20.8.2 Real math functions

The system functions in [Table 20-4](#) shall accept real value arguments and return a `real` result type. Their behavior shall match the equivalent C language standard math library function indicated.

Table 20-4—SystemVerilog to C real math function cross-listing

SystemVerilog function	Equivalent C function	Description
<code>\$ln(x)</code>	<code>log(x)</code>	Natural logarithm
<code>\$log10(x)</code>	<code>log10(x)</code>	Decimal logarithm
<code>\$exp(x)</code>	<code>exp(x)</code>	Exponential
<code>\$sqrt(x)</code>	<code>sqrt(x)</code>	Square root
<code>\$pow(x, y)</code>	<code>pow(x, y)</code>	$x^{**}y$
<code>\$floor(x)</code>	<code>floor(x)</code>	Floor
<code>\$ceil(x)</code>	<code>ceil(x)</code>	Ceiling
<code>\$sin(x)</code>	<code>sin(x)</code>	Sine
<code>\$cos(x)</code>	<code>cos(x)</code>	Cosine
<code>\$tan(x)</code>	<code>tan(x)</code>	Tangent
<code>\$asin(x)</code>	<code>asin(x)</code>	Arc-sine
<code>\$acos(x)</code>	<code>acos(x)</code>	Arc-cosine
<code>\$atan(x)</code>	<code>atan(x)</code>	Arc-tangent
<code>\$atan2(y,x)</code>	<code>atan2(y,x)</code>	Arc-tangent of y/x
<code>\$hypot(x, y)</code>	<code>hypot(x, y)</code>	$\sqrt{x^2+y^2}$
<code>\$sinh(x)</code>	<code>sinh(x)</code>	Hyperbolic sine
<code>\$cosh(x)</code>	<code>cosh(x)</code>	Hyperbolic cosine
<code>\$tanh(x)</code>	<code>tanh(x)</code>	Hyperbolic tangent
<code>\$asinh(x)</code>	<code>asinh(x)</code>	Arc-hyperbolic sine

Table 20-4—SystemVerilog to C real math function cross-listing (continued)

SystemVerilog function	Equivalent C function	Description
<code>\$acosh(x)</code>	<code>acosh(x)</code>	Arc-hyperbolic cosine
<code>\$atanh(x)</code>	<code>atanh(x)</code>	Arc-hyperbolic tangent

20.9 Severity tasks

```

severity_message_task ::=
    fatal_message_task
    | nonfatal_message_task
fatal_message_task ::= $fatal [ ( finish_number [ , list_of_arguments ] ) ] ;
nonfatal_message_task ::= severity_task [ ( [ list_of_arguments ] ) ] ;
severity_task ::= $error | $warning | $info
finish_number ::= 0 | 1 | 2

```

Syntax 20-9—Severity system task syntax (not in Annex A)

SystemVerilog provides special text messaging system tasks that can be used to flag various exception conditions. The tasks are defined as follows:

- `$fatal` shall generate a run-time fatal error, which terminates the simulation with an error code. The first argument passed to `$fatal` shall be consistent with the corresponding argument to the `$finish` system task (see 20.2), which sets the level of diagnostic information reported by the tool. Calling `$fatal` results in an implicit call to `$finish`.
- `$error` shall be a run-time error.
- `$warning` shall be a run-time warning.
- `$info` shall indicate that the message carries no specific severity.

Each of the severity system tasks can include optional user-defined information to be reported. The user-defined message shall use the same syntax as the `$display` system task (see 21.2.1) and thus can include any number of arguments.

All of the severity system tasks shall print a tool-specific message, indicating the severity of the exception condition and specific information about the condition, which shall include the following information:

- The file name and line number of the severity system task call. The file name and line number shall be same as `__FILE__` and `__LINE__` compiler directives respectively.
- The hierarchical name of the scope in which the severity system task call is made.
- For simulation tools, the simulation run time at which the severity system task is called.

The tool-specific message shall include the user-defined message if specified.

20.10 Elaboration system tasks

It is often necessary to validate the actual parameter values used in a SystemVerilog model and report any error without generating the executable simulation model. This is achieved by using elaboration system tasks. These tasks have the same names as the severity system tasks (see 20.9) that can be used during

simulation. However, the elaboration system tasks shall be called outside procedural code and their activation can be controlled by conditional generate constructs. If such a task is called from within a procedure, then it becomes a simulation-time severity system task.

```

elaboration_system_task ::= //from A.1.4
    $fatal [ ( finish_number [ , list_of_arguments ] ) ] ;
    | $error [ ( [ list_of_arguments ] ) ] ;
    | $warning [ ( [ list_of_arguments ] ) ] ;
    | $info [ ( [ list_of_arguments ] ) ] ;
finish_number ::= 0 | 1 | 2

```

Syntax 20-10—Elaboration system task syntax (excerpt from [Annex A](#))

list_of_arguments may only contain a formatting string and constant expressions, including constant function calls. If a call to such a task remains in the elaborated model after any generate construct expansion, the task is executed. Depending on the severity of the task the elaboration may be aborted or continue to successful completion. If more than one elaboration system task call is present, they may be executed in any order.

If `$fatal` is executed then after outputting the message the elaboration may be aborted, and in no case shall simulation be executed. Some of the elaboration system task calls may not be executed either. The *finish_number* may be used in an implementation-specific manner.

If `$error` is executed then the message is issued and the elaboration continues. However, no simulation shall be executed.

The other two tasks, `$warning` and `$info`, only output their text message but do not affect the rest of the elaboration and the simulation.

All of the elaboration system tasks shall print a tool-specific message, indicating the severity of the exception condition and specific information about the condition, which shall include the following information:

- The file name and line number of the elaboration system task call. The file name and line number shall be same as `__FILE__` and `__LINE__` compiler directives respectively.
- The hierarchical name of the scope in which the elaboration system task call is made.

The tool-specific message shall include the user-defined message if specified.

Example 1—Sometimes it is desirable to validate elaboration-time constants, such as bounds on a parameter, in a way that can be enforced during model elaboration. In this example, if the module parameter value is outside the range 1 to 8, an error is issued and the model elaboration is aborted.

```

module test #(N = 1) (input [N-1:0] in, output [N-1:0] out);
    if ((N < 1) || (N > 8)) // conditional generate construct
        $error("Parameter N has an invalid value of %0d", N);
    assign out = in;
endmodule

```

Example 2—In this simple example, the generate construct builds a concatenation (##1) of subsequences, each of length 1, over a bit from a vector passed as argument to the top sequence definition. Elaboration system tasks are used to indicate if the vector is only a 1-bit vector, otherwise informational messages are issued that indicate which conditional branches were generated.

```
generate
  if ($bits(vect) == 1) begin : err $error("Only a 1-bit vector"); end
  for (genvar i = 0; i < $bits(vect); i++) begin : Loop
    if (i==0) begin : Cond
      sequence t; vect[0]; endsequence
      $info("i=0 branch generated");
    end : Cond
    else begin : Cond
      sequence t; vect[i] ##1 Loop[i-1].Cond.t; endsequence
      $info("i = %0d branch generated", i);
    end : Cond
  end : Loop
endgenerate

// instantiate the last generated sequence in a property
property p;
  @(posedge clk) trig |-> Loop[$bits(vect)-1].Cond.t;
endproperty
```

20.11 Assertion control system tasks

```
assert_control_task ::=
  assert_task [ ( levels [ , list_of_modules_or_assertions ] ) ] ;
assert_task ::=
  $asserton
  | $assertoff
  | $assertkill
list_of_modules_or_assertions ::=
  module_or_assertion { , module_or_assertion }
module_or_assertion ::=
  module_identifier
  | assertion_identifier
  | hierarchical_identifier
```

Syntax 20-11—Assertion control syntax (not in [Annex A](#))

SystemVerilog provides the following three system tasks to control the evaluation of assertion statements:

- `$assertoff` shall stop the checking of all specified assertions until a subsequent `$asserton`. An assertion that is already executing, including execution of the pass or fail statement, is not affected. In the case of a deferred assertion (see [16.4](#)), currently queued reports are not flushed and may still mature, though further checking is prevented until the `$asserton`. In the case of a pending procedural assertion instance (see [16.15.6](#)), currently queued instances are not flushed and may still mature, though no new instances may be queued until the `$asserton`.
- `$assertkill` shall abort execution of any currently executing specified assertions and then stop the checking of all specified assertions until a subsequent `$asserton`. This also flushes any queued pending reports of deferred assertions (see [16.4](#)) or pending procedural assertion instances (see [16.15.6](#)) that have not yet matured.
- `$asserton` shall reenable the execution of all specified assertions.

The details related to the behavior of `$assertkill` and `$assertoff` for assertions referring to global clocking future sampled value functions are explained in [16.9.4](#).

When invoked with no arguments, the system task shall apply to all assertions. When the task is specified with arguments, the first argument indicates levels of the hierarchy, consistent with the corresponding argument to the \$dumpvars system task (see 21.7.1.2). Subsequent arguments specify which scopes of the model to control. These arguments can specify entire modules or individual assertions.

Table 20-5 lists the VPI callbacks (see 36.9.2 and 39.4) corresponding to the assertion control system task’s invocation.

Table 20-5—VPI callbacks for assertion control tasks

Task	No arguments – assertion system callback (see 39.4.1)	With arguments – assertion callback (see 39.4.2)
\$asserton	cbAssertionSysOn	cbAssertionEnable
\$assertoff	cbAssertionSysOff	cbAssertionDisable
\$assertkill	cbAssertionSysKill	cbAssertionReset + cbAssertionDisable

20.12 Assertion action control system tasks

```

assert_action_control_task ::=
    assert_action_task [ ( levels [ , list_of_modules_or_assertions ] ) ] ;
assert_action_task ::=
    $assertpasson
    | $assertpassoff
    | $assertfailon
    | $assertfailoff
    | $assertnonvacuouson
    | $assertvacuousoff
list_of_modules_or_assertions ::=
    module_or_assertion { , module_or_assertion }
module_or_assertion ::=
    module_identifier
    | assertion_identifier
    | hierarchical_identifier
    
```

Syntax 20-12—Assertion action control syntax (not in Annex A)

SystemVerilog provides the following six system tasks to control the execution of assertion action blocks that are associated with assertion statements and the **expect** statement:

- \$assertpassoff shall stop execution of the pass action for vacuous and nonvacuous success of all the specified assertions. Execution of the pass action for both vacuous and nonvacuous successes can be re-enabled subsequently by \$assertpasson, while the execution of pass action for only nonvacuous successes can be enabled subsequently by \$assertnonvacuouson. An assertion that is already executing, including execution of the pass or fail action, is not affected. By default, the pass action is executed.
- \$assertfailoff shall stop execution of the fail action of all the specified assertions until a subsequent \$assertfailon. An assertion that is already executing, including execution of the pass or

fail action, is not affected. By default, the fail action is executed. This task also affects the execution of default fail action block.

- `$assertvacuousoff` shall stop execution of the pass action of all the specified assertions on vacuous success until a subsequent `$assertpasson`. An assertion that is already executing, including execution of the pass or fail action, is not affected. By default, the pass action is executed on vacuous success. Refer to [16.15.8](#) for the definition of vacuous success.
- `$assertpasson` shall enable execution of the pass action for vacuous and nonvacuoussuccess of all the specified assertions. An assertion that is already executing, including execution of the pass or fail action, is not affected.
- `$assertfailon` shall enable execution of the fail action of all the specified assertions. An assertion that is already executing, including execution of the pass or fail action, is not affected. This task also affects the execution of the default fail action block.
- `$assertnonvacuouson` shall enable execution of the pass action of all the specified assertions on nonvacuous success. An assertion that is already executing, including execution of the pass or fail action, is not affected. Refer to [16.15.8](#) for the definition of vacuous success.

The details related to the behavior of `$assertpassoff`, `$assertfailoff`, and `$assertvacuousoff` for assertions referring to global clocking sampled future value functions are explained in [16.9.4](#).

When invoked with no arguments, the system task shall apply to all the assertions. When the system task is specified with arguments, the first argument indicates levels of the hierarchy, consistent with the corresponding argument to the `$dumpvars` system task (see [21.7.1.2](#)). Subsequent arguments specify which scopes of the model to control. These arguments can specify entire scopes (module, program, interface, always procedure, or initial procedure) or individual assertions.

These system tasks shall not affect the execution of pass or fail actions until the system task is executed. These system tasks shall not affect the statistics counters for the assertions.

[Table 20-6](#) lists the VPI callbacks (see [36.9.2](#) and [39.4](#)) corresponding to the assertion action control system tasks.

Table 20-6—VPI callbacks for assertion action control tasks

Task	No arguments – assertion system callback (see 39.4.1)	With arguments – assertion callback (see 39.4.2)
<code>\$assertpasson</code>	<code>cbAssertionSysEnablePassAction</code>	<code>cbAssertionEnablePassAction</code>
<code>\$assertfailon</code>	<code>cbAssertionSysEnableFailAction</code>	<code>cbAssertionEnableFailAction</code>
<code>\$assertpassoff</code>	<code>cbAssertionSysDisablePassAction</code>	<code>cbAssertionDisablePassAction</code>
<code>\$assertfailoff</code>	<code>cbAssertionSysDisableFailAction</code>	<code>cbAssertionDisableFailAction</code>
<code>\$assertnonvacuouson</code>	<code>cbAssertionSysEnableNonvacuousAction</code>	<code>cbAssertionEnableNonvacuousAction</code>
<code>\$assertvacuousoff</code>	<code>cbAssertionSysDisableVacuousAction</code>	<code>cbAssertionDisableVacuousAction</code>

20.13 Assertion system functions

```

assert_boolean_function ::=
    assert_function ( expression )
assert_function ::=
    $onehot
    | $onehot0
    | $isunknown

```

Syntax 20-13—Assertion system function syntax (not in [Annex A](#))

Assertions are commonly used to evaluate certain specific characteristics of a design implementation, such as whether a particular signal is “one-hot”. The following system functions are included to facilitate such common assertion functionality:

- `$onehot` returns true if 1 and only 1 bit of expression is high.
- `$onehot0` returns true if at most 1 bit of expression is high.
- `$isunknown` returns true if any bit of the expression is x or z. This is equivalent to `^expression === 'bx`.

All of the above system functions shall have a return type of `bit`. A return value of `1'b1` shall indicate true, and a return value of `1'b0` shall indicate false.

A function is provided to return the sampled value of an expression.

```
$sampled ( expression )
```

The following functions are provided for assertions to detect changes in values between two adjacent clock ticks:

```

$rose ( expression [ , [clocking_event] ] )
$fell ( expression [ , [clocking_event] ] )
$stable ( expression [ , [clocking_event] ] )
$changed ( expression [ , [clocking_event] ] )

```

The past values can be accessed with the `$past` function.

```
$past ( expression [ , [number_of_ticks] ] [ , [expression2] ] [ , [clocking_event]] ] )
```

Functions `$sampled`, `$rose`, `$fell`, `$stable`, `$changed`, and `$past` are discussed in [16.9.3](#).

The number of ones in a bit vector expression can be determined with the `$countones` function.

```
$countones ( expression )
```

`$countones` is discussed in [16.12](#).

The following functions allow to access the sampled value of an expression at the immediate past and future ticks of the global clock and to detect changes in the sampled value from the past (resp. current) tick of the global clock to its current (resp. next) tick.

Global clocking past sampled value functions:

```
$past_gclk ( expression )
```

`$rose_gclk (expression)`
`$fell_gclk (expression)`
`$stable_gclk (expression)`
`$changed_gclk (expression)`

Global clocking future sampled value functions:

`$future_gclk (expression)`
`$rising_gclk (expression)`
`$falling_gclk (expression)`
`$steady_gclk (expression)`
`$changing_gclk (expression)`

These functions are discussed in [16.9.4](#).

20.14 Coverage system functions

SystemVerilog has several built-in system functions for obtaining test coverage information: `$coverage_control`, `$coverage_get_max`, `$coverage_get`, `$coverage_merge`, and `$coverage_save`. The coverage system functions are described in [40.3.2](#).

System tasks and system functions are also provided to help manage coverage data collection and reporting: `$set_coverage_db_name`, `$load_coverage_db`, and `$get_coverage`. The coverage data system tasks and system functions are described in [19.9](#).

20.15 Probabilistic distribution functions

Constrained pseudo-random value generation (see [Clause 18](#)) uses the `.randomize` method and two special system functions, `$urandom` and `$urandom_range` (see [18.13](#)).

In addition to the constrained random value generation discussed in [Clause 18](#), SystemVerilog provides a set of random number generators that return integer values distributed according to standard probabilistic functions. These are: `$random`, `$dist_uniform`, `$dist_normal`, `$dist_exponential`, `$dist_poisson`, `$dist_chi_square`, `$dist_t`, and `$dist_erlang`.

The value generation algorithm for these system functions is part of this standard, ensuring repeatable random value sets across different implementations. The C source code for this algorithm is included in [Annex N](#).

20.15.1 \$random function

The syntax for the system function `$random` is shown in [Syntax 20-14](#).

```
random_function ::=  
    $random [ ( seed ) ]
```

Syntax 20-14—Syntax for \$random (not in [Annex A](#))

The system function `$random` provides a mechanism for generating random numbers. The function returns a new 32-bit random number each time it is called. The random number is a signed integer; it can be positive or negative. For further information on probabilistic random number generators, see [20.15.2](#).

The `seed` argument controls the numbers that `$random` returns so that different seeds generate different random streams. The `seed` argument shall be an integral variable. The seed value should be assigned to this variable prior to calling `$random`.

Example 1—Where `b` is greater than 0, the expression `($random % b)` gives a number in the following range: `[(-b+1) : (b-1)]`.

The following code fragment shows an example of random number generation between `-59` and `59`:

```
bit [23:0] rand;
rand = $random % 60;
```

Example 2—The following example shows how adding the concatenation operator to the preceding example gives `rand` a positive value from 0 to 59:

```
bit [23:0] rand;
rand = {$random} % 60;
```

20.15.2 Distribution functions

The syntax for the probabilistic distribution functions is shown in [Syntax 20-15](#).

```
dist_functions ::=
    $dist_uniform ( seed , start , end )
  | $dist_normal ( seed , mean , standard_deviation )
  | $dist_exponential ( seed , mean )
  | $dist_poisson ( seed , mean )
  | $dist_chi_square ( seed , degree_of_freedom )
  | $dist_t ( seed , degree_of_freedom )
  | $dist_erlang ( seed , k_stage , mean )
```

Syntax 20-15—Syntax for probabilistic distribution functions (not in [Annex A](#))

All arguments to the system functions are integer values. For the exponential, poisson, chi-square, t, and erlang functions, the arguments `mean`, `degree_of_freedom`, and `k_stage` shall be greater than 0.

Each of these functions returns a pseudo-random number whose characteristics are described by the function name. In other words, `$dist_uniform` returns random numbers uniformly distributed in the interval specified by its arguments.

For each system function, the `seed` argument is an `inout` argument; that is, a value is passed to the function, and a different value is returned. The system functions shall always return the same value given the same `seed`. This facilitates debugging by making the operation of the system repeatable. The `seed` argument should be an integral variable that is initialized by the user and only updated by the system function so that the desired distribution is achieved.

In the `$dist_uniform` function, the `start` and `end` arguments are integer inputs that bound the values returned. The `start` value should be smaller than the `end` value.

The `mean` argument, used by `$dist_normal`, `$dist_exponential`, `$dist_poisson`, and `$dist_erlang`, is an integer input that causes the average value returned by the function to approach the value specified.

The `standard_deviation` argument used with the `$dist_normal` function is an integer input that helps determine the shape of the density function. Larger numbers for `standard_deviation` spread the returned values over a wider range.

The `degree_of_freedom` argument used with the `$dist_chi_square` and `$dist_t` functions is an integer input that helps determine the shape of the density function. Larger numbers spread the returned values over a wider range.

20.16 Stochastic analysis tasks and functions

This subclause describes a set of system tasks and system functions that manage queues. These tasks facilitate implementation of stochastic queueing models.

The set of system tasks and system functions that create and manage queues follows:

```
$q_initialize ( q_id , q_type , max_length , status ) ;  
$q_add ( q_id , job_id , inform_id , status ) ;  
$q_remove ( q_id , job_id , inform_id , status ) ;  
$q_full ( q_id , status )  
$q_exam ( q_id , q_stat_code , q_stat_value , status ) ;
```

20.16.1 \$q_initialize

The `$q_initialize` system task creates new queues. The `q_id` argument is an integer input that shall uniquely identify the new queue. The `q_type` argument is an integer input. The value of the `q_type` argument specifies the type of the queue as shown in [Table 20-7](#).

Table 20-7—Types of queues of \$q_type values

q_type value	Type of queue
1	First-in, first-out
2	Last-in, first-out

The `max_length` argument is an integer input that specifies the maximum number of entries allowed on the queue. The success or failure of the creation of the queue is returned as an integer value in `status`. The error conditions and corresponding values of `status` are described in [Table 20-9](#) in [20.16.6](#).

20.16.2 \$q_add

The `$q_add` system task places an entry on a queue. The `q_id` argument is an integer input that indicates to which queue to add the entry. The `job_id` argument is an integer input that identifies the job.

The `inform_id` argument is an integer input that is associated with the queue entry. Its meaning is user-defined. For example, the `inform_id` argument can represent execution time for an entry in a CPU model. The `status` code reports on the success of the operation or error conditions as described in [Table 20-9](#).

20.16.3 \$q_remove

The \$q_remove system task receives an entry from a queue. The q_id argument is an integer input that indicates from which queue to remove. The job_id argument is an integer output that identifies the entry being removed. The inform_id argument is an integer output that the queue manager stored during \$q_add. Its meaning is user-defined. The status code reports on the success of the operation or error conditions as described in [Table 20-9](#).

20.16.4 \$q_full

The \$q_full system function checks whether there is room for another entry on a queue. It returns 0 when the queue is not full and 1 when the queue is full. The status code reports on the success of the operation or error conditions as described in [Table 20-9](#).

20.16.5 \$q_exam

The \$q_exam system task provides statistical information about activity at the queue q_id. It returns a value in q_stat_value depending on the information requested in q_stat_code. The values of q_stat_code and the corresponding information returned in q_stat_value are described in [Table 20-8](#). The status code reports on the success of the operation or error conditions as described in [Table 20-9](#).

Table 20-8—Argument values for \$q_exam system task

Value requested in q_stat_code	Information received back from q_stat_value
1	Current queue length
2	Mean interarrival time
3	Maximum queue length
4	Shortest wait time ever
5	Longest wait time for jobs still in the queue
6	Average wait time in the queue

20.16.6 Status codes

All of the queue management tasks and functions return an output status code. The status code values and corresponding information are described in [Table 20-9](#).

Table 20-9—Status code values

Status code values	What it means
0	OK
1	Queue full, cannot add
2	Undefined q_id
3	Queue empty, cannot remove
4	Unsupported queue type, cannot create queue
5	Specified length <= 0, cannot create queue

Table 20-9—Status code values (continued)

Status code values	What it means
6	Duplicate q_id, cannot create queue
7	Not enough memory, cannot create queue

20.17 Programmable logic array (PLA) modeling system tasks

The modeling of PLA devices is provided by a group of system tasks. This subclause describes the syntax and use of these system tasks and the formats of the logic array personality file. The syntax for PLA modeling system task is shown in [Syntax 20-16](#).

```

pla_system_task ::=
    $array_type$logic$format ( memory_identifier , input_terms , output_terms ) ;
array_type ::=
    sync | async
logic ::=
    and | or | nand | nor
format ::=
    array | plane
memory_identifier ::=
    identifier
input_terms ::=
    expression
output_terms ::=
    variable_lvalue
    
```

Syntax 20-16—Syntax for PLA modeling system task (not in [Annex A](#))

The input terms can be nets or variables whereas the output terms shall only be variables.

The PLA syntax allows for the system tasks as shown in [Table 20-10](#).

Table 20-10—PLA modeling system tasks

\$async\$and\$array	\$sync\$and\$array	\$async\$and\$plane	\$sync\$and\$plane
\$async\$nand\$array	\$sync\$nand\$array	\$async\$nand\$plane	\$sync\$nand\$plane
\$async\$or\$array	\$sync\$or\$array	\$async\$or\$plane	\$sync\$or\$plane
\$async\$nor\$array	\$sync\$nor\$array	\$async\$nor\$plane	\$sync\$nor\$plane

20.17.1 Array types

The modeling of both synchronous and asynchronous arrays is provided by the PLA system tasks. The synchronous forms control the time at which the logic array shall be evaluated and the outputs shall be updated. For the asynchronous forms, the evaluations are automatically performed whenever an input term changes value or any word in the personality memory is changed.

For both the synchronous and asynchronous forms, the output terms are updated without any delay.

An example of an asynchronous system call is as follows:

```

wire      a1, a2, a3, a4, a5, a6, a7;
logic     b1, b2, b3;
wire [1:7] awire;
logic [1:3] breg;

$async$and$array(mem, {a1, a2, a3, a4, a5, a6, a7}, {b1, b2, b3});

```

or

```

$async$and$array(mem, awire, breg);

```

An example of a synchronous system call is as follows:

```

$sync$or$plane(mem, {a1, a2, a3, a4, a5, a6, a7}, {b1, b2, b3});

```

20.17.2 Array logic types

The logic arrays are modeled with and, or, nand, and nor logic planes. This applies to all array types and formats.

An example of a nor plane system call is as follows:

```

$async$nor$plane(mem, {a1, a2, a3, a4, a5, a6, a7}, {b1, b2, b3});

```

An example of a nand plane system call is as follows:

```

$sync$nand$plane(mem, {a1, a2, a3, a4, a5, a6, a7}, {b1, b2, b3});

```

20.17.3 Logic array personality declaration and loading

The logic array personality is declared as an array of variables that is as wide as the number of input terms and as deep as the number of output terms.

The personality of the logic array is normally loaded into the memory from a text data file using the system tasks `$readmemb` or `$readmemh` (see 21.4). Alternatively, the personality data can be written directly into the memory using the procedural assignment statements. PLA personalities can be changed dynamically at any time during simulation simply by changing the contents of the memory. The new personality shall be reflected on the outputs of the logic array at the next evaluation.

The following example shows a logic array with n input terms and m output terms:

```

logic [1:n] mem[1:m];

```

As shown in the examples in 20.17, PLA input terms, output terms, and memory shall be specified in ascending order.

20.17.4 Logic array personality formats

Two separate personality formats are supported and are differentiated by using either an array system call or a plane system call. The array system call allows for a 1 or 0 in the memory that has been declared. A 1 means take the input value, and a 0 means do not take the input value.

The plane system call complies with the University of California at Berkeley format for Espresso¹¹. Each bit of the data stored in the array has the following meaning:

- 0 Take the complemented input value.
- 1 Take the true input value.
- x Take the “worst case” of the input value.
- z Do-not-care; the input value is of no significance.
- ? Same as z.

Example 1—The following example illustrates an array with logic equations:

```
b1 = a1 & a2  
b2 = a3 & a4 & a5  
b3 = a5 & a6 & a7
```

The PLA personality is as follows:

```
1100000 in mem[1]  
0011100 in mem[2]  
0000111 in mem[3]
```

The module for the PLA is as follows:

```
module async_array(a1,a2,a3,a4,a5,a6,a7,b1,b2,b3);  
  input a1, a2, a3, a4, a5, a6, a7 ;  
  output b1, b2, b3;  
  logic [1:7] mem[1:3]; // memory declaration for array personality  
  logic b1, b2, b3;  
  initial begin  
    // set up the personality from the file array.dat  
    $readmemb("array.dat", mem);  
    // set up an asynchronous logic array with the input  
    // and output terms expressed as concatenations  
    $asyncl$and$array(mem, {a1,a2,a3,a4,a5,a6,a7}, {b1,b2,b3});  
  end  
endmodule
```

Where the file `array.dat` contains the binary data for the PLA personality:

```
1100000  
0011100  
0000111
```

A synchronous version of this example has the following description:

```
module sync_array(a1,a2,a3,a4,a5,a6,a7,b1,b2,b3,clk);  
  input a1, a2, a3, a4, a5, a6, a7, clk;  
  output b1, b2, b3;  
  logic [1:7] mem[1:3]; // memory declaration  
  logic b1, b2, b3;  
  initial begin  
    // set up the personality  
    $readmemb("array.dat", mem);  
    // set up a synchronous logic array to be evaluated  
    // when a positive edge on the clock occurs
```

¹¹Information on Espresso can be found at <http://embedded.eecs.berkeley.edu/pubs/downloads/espresso/index.htm>.

```

    forever @(posedge clk)
        $async$and$array(mem, {a1, a2, a3, a4, a5, a6, a7}, {b1, b2, b3});
end
endmodule

```

Example 2—An example of the usage of the plane format tasks follows. The logical function of this PLA is shown first, followed by the PLA personality in the new format, the SystemVerilog description using the `$async$and$plane` system task, and finally the result of running the simulation.

The logical function of the PLA is as follows:

```

b[1] = a[1] & ~a[2];
b[2] = a[3];
b[3] = ~a[1] & ~a[3];
b[4] = 1;

```

The PLA personality is as follows:

```

3'b10?
3'b??1
3'b0?0
3'b???

```

An example of using the `$async$and$plane` system task is as follows:

```

module pla;
    `define rows 4
    `define cols 3
    logic [1:`cols] a, mem[1:`rows];
    logic [1:`rows] b;
    initial begin
        // PLA system call
        $async$and$plane(mem, a[1:3], b[1:4]);
        mem[1] = 3'b10?;
        mem[2] = 3'b??1;
        mem[3] = 3'b0?0;
        mem[4] = 3'b???;
        // stimulus and display
        #10 a = 3'b111;
        #10 $displayb(a, " -> ", b);
        #10 a = 3'b000;
        #10 $displayb(a, " -> ", b);
        #10 a = 3'bxxx;
        #10 $displayb(a, " -> ", b);
        #10 a = 3'b101;
        #10 $displayb(a, " -> ", b);
    end
endmodule

```

The output is as follows:

```

111 -> 0101
000 -> 0011
xxx -> xxx1
101 -> 1101

```

20.18 Miscellaneous tasks and functions

20.18.1 \$system

The syntax for \$system is shown in [Syntax 20-17](#).

```
system_call ::=  
    $system ( [ " terminal_command_line " ] )
```

Syntax 20-17—System function syntax (not in [Annex A](#))

\$system makes a call to the C function system(). The C function executes the argument passed to it as if the argument was executed from the terminal. \$system can be called as either a task or a function. When called as a function, it returns the return value of the call to system() with data type **int**. If \$system is called with no string argument, the C function system() will be called with the NULL string.

The example below calls \$system as a task to rename a file.

```
module top;  
    initial $system("mv design.v adder.v");  
endmodule
```

21. I/O system tasks and system functions

21.1 General

This clause describes input/output (I/O) system tasks and system functions. These system tasks and system functions are divided into several categories as follows:

Display tasks (21.2)

\$display	\$write
\$displayb	\$writeb
\$displayh	\$writeh
\$displayo	\$writeo
\$strobe	\$monitor
\$strobeb	\$monitorb
\$strobeh	\$monitoh
\$strobeo	\$monitoo
	\$monitoroff
	\$monitoron

File I/O tasks and functions (21.3)

\$fclose	\$fopen
\$fdisplay	\$fwrite
\$fdisplayb	\$fwriteb
\$fdisplayh	\$fwriteh
\$fdisplayo	\$fwriteo
\$fstrobe	\$fmonitor
\$fstrobeb	\$fmonitorb
\$fstrobeh	\$fmonitoh
\$fstrobeo	\$fmonitoo
\$fwrite	\$format
\$fwriteb	\$formatf
\$fwriteh	\$fgetc
\$fwriteo	\$fputc
\$fscanf	\$fgets
\$fread	\$sscanf
\$fseek	\$rewind
\$fflush	\$ftell
\$feof	\$ferror

Memory load tasks (21.4)

\$readmemb	\$readmemh
------------	------------

Memory dump tasks (21.5)

\$writememb	\$writememh
-------------	-------------

Command line input (21.6)

\$test\$plusargs	\$value\$plusargs
------------------	-------------------

VCD tasks (21.7)

\$dumpfile	\$dumpvars
\$dumpoff	\$dumpon
\$dumpall	\$dumplimit
\$dumpflush	\$dumpports
\$dumpportsoff	\$dumpportson
\$dumpportsall	\$dumpportslimit
\$dumpportsflush	

21.2 Display system tasks

The display group of system tasks is divided into three categories: the display and write tasks, strobed monitoring tasks, and continuous monitoring tasks.

21.2.1 The display and write tasks

The syntax for \$display and \$write system tasks is shown in [Syntax 21-1](#).

```
display_tasks ::=
    display_task_name [ ( list_of_arguments ) ] ;
display_task_name ::=
    $display | $displayb | $displayo | $displayh
    | $write | $writeb | $writeo | $writeh
```

Syntax 21-1—Syntax for \$display and \$write system tasks (not in Annex A)

These are the main system task routines for displaying information. The two sets of tasks are identical except that \$display automatically adds a newline character to the end of its output, whereas the \$write task does not.

The \$display and \$write tasks display their arguments in the same order as they appear in the argument list. Each argument can be a quoted string literal, an expression that returns a value, or an empty argument. (An empty argument is characterized by two adjacent commas in the argument list.) Any argument expression of either a **string** data type or an unpacked array of **byte** data type that has no corresponding format specification shall be formatted as a character string. Any expression argument of any other unpacked data type that has no corresponding format specification shall be illegal.

The contents of string literal arguments are output literally except when certain escape sequences are inserted to display special characters or to specify the display format for a subsequent expression.

Escape sequences are inserted into a string in the following three ways:

- The special character \ indicates that the character to follow is a literal or nonprintable character (see [Table 21-1](#)).
- The special character % indicates that the next character should be interpreted as a format specification that establishes the display format for a subsequent expression argument (see [Table 21-2](#)). For each % character (except %m, %l, and %%) that appears in a string, a corresponding expression argument shall be supplied after the string.
- The special character string %% indicates the display of the percent sign character % (see [Table 21-1](#)).

An empty argument produces a single space character in the display.

The \$display task, when invoked without arguments, simply prints a newline character. A \$write task supplied without arguments prints nothing at all.

21.2.1.1 Escape sequences for special characters

The escape sequences given in [Table 21-1](#), when included in a string argument, cause special characters to be displayed.

Table 21-1—Escape sequences for printing special characters

Escape string	Character produced by escape string
\n	Newline character
\t	Tab character
\\	\ character
\"	" character

Table 21-1—Escape sequences for printing special characters (continued)

Escape string	Character produced by escape string
\v	vertical tab
\f	form feed
\a	bell
%%	The % character
\ddd	A character specified in 1 to 3 octal digits, where $0 \leq d \leq 7$ If fewer than three characters are used, the following character shall not be an octal digit. Implementations may issue an error if the character represented is greater than \377.
\xdd	A character specified in 2 hexadecimal digits, where $0 \leq d \leq F$

For example:

```

module disp;
  initial begin
    $display("\t\n\"123");
  end
endmodule

```

Simulating this example shall display the following:

```

\t
"s

```

An escaped character not appearing in [Table 21-1](#) shall cause the character to be printed by itself. For example, a string argument “\b” shall print simply “b”.

21.2.1.2 Format specifications

[Table 21-2](#) shows the escape sequences used for format specifications. Each escape sequence, when included in a string literal argument, specifies the display format for a subsequent expression. For each % character (except %m, %l, and %%) that appears in a string literal, a corresponding expression shall follow the string in the argument list. The value of the expression replaces the format specification when the string is displayed. It shall be an error if an undefined format specifier appears in a string literal argument.

Any expression argument that has no corresponding format specification is displayed using the default decimal format in \$display and \$write, binary format in \$displayb and \$writeb, octal format in \$displayo and \$writeo, and hexadecimal format in \$displayh and \$writeh.

Table 21-2—Escape sequences for format specifications

Argument	Description
%h or %H %x or %X	Display in hexadecimal format
%d or %D	Display in decimal format
%o or %O	Display in octal format
%b or %B	Display in binary format

Table 21-2—Escape sequences for format specifications (continued)

Argument	Description
%c or %C	Display in ASCII character format
%l or %L	Display library binding information
%v or %V	Display net signal strength
%m or %M	Display hierarchical name
%p or %P	Display as an assignment pattern
%s or %S	Display as a string
%t or %T	Display in current time format
%u or %U	Unformatted 2 value data
%z or %Z	Unformatted 4 value data

The integer format specifiers, %h, %x, %d, %o, %b, %c, %u, and %z (uppercase or lowercase), may be used with any of the SystemVerilog integral data types, including enumerated types and packed aggregate data types. These format specifiers can also be used with user-defined types that have been defined (using `typedef`) to be represented using one of these basic types. They shall not be used with any unpacked aggregate type.

The formatting specification %l (or %L) is defined for displaying the library information of the specific module. This information shall be displayed as "library.cell" corresponding to the library name from which the current module instance was extracted and the cell name of the current module instance. See [Clause 33](#) for information on libraries and configuring designs.

The formatting specification %u (or %U) is defined for writing data without formatting (binary values). The application shall transfer the 2 value binary representation of the specified data to the output stream. This escape sequence can be used with any of the existing display system tasks, although \$fwrite (see [21.3.2](#)) should be the preferred one to use. Any unknown or high-impedance bits in the source shall be treated as zero. This formatting specifier is intended to be used to support transferring data to and from external programs that have no concept of x and z. Applications that require preservation of x and z are encouraged to use the %z I/O format specification.

- For packed data, %u and %z are defined to operate as though the operation were applied to the equivalent vector.
- For unpacked struct data, %u and %z are defined to apply as though the operation were performed on each member in declaration order.
- For unpacked union data, %u and %z are defined to apply as though the operation were performed on the first member in declaration order.
- %u and %z are not defined on unpacked arrays.
- The count of data items read by a %u or %z for an aggregate type is always either 1 or 0; the individual members are not counted separately.

The data shall be written to the file in the native endian format of the underlying system [i.e., in the same endian order as if the PLI was used and the C language write (2) system call was used]. The data shall be written in units of 32 bits with the word containing the LSB written first.

NOTE 1—For POSIX applications, it might be necessary to open files for unformatted I/O with the wb, wb+, or w+b specifiers to avoid the systems implementation of I/O altering patterns in the unformatted stream that match special characters.

The formatting specification %z (or %Z) is defined for writing data without formatting (binary values). The application shall transfer the 4 value binary representation of the specified data to the output stream. This escape sequence can be used with any of the existing display system tasks, although \$fwrite (see 21.3.2) should be the preferred one to use.

This formatting specifier is intended to be used to support transferring data to and from external programs that recognize and support the concept of x and z. Applications that do not require the preservation of x and z are encouraged to use the %u I/O format specification.

The data shall be written to the file in the native endian format of the underlying system [i.e., in the same endian order as if the PLI was used, the data were in a s_vpi_vecval structure (see Figure 38-8 in 38.15), and the C language write(2) system call was used to write the structure to disk]. The data shall be written in units of 32 bits with the structure containing the LSB written first.

NOTE 2—For POSIX applications, it might be necessary to open files for unformatted I/O with the wb, wb+, or w+b specifiers to avoid the systems implementation of I/O altering patterns in the unformatted stream that match special characters.

The format specifications in Table 21-3 are used with real numbers (i.e., real and shortreal types) and have the full formatting capabilities available in the C language. For example, the format specification %10.3g specifies a minimum field width of 10 with 3 fractional digits.

Table 21-3—Format specifications for real numbers

Argument	Description
%e or %E	Display 'real' in an exponential format
%f or %F	Display 'real' in a decimal format
%g or %G	Display 'real' in exponential or decimal format, whichever format results in the shorter printed output

The net signal strength, hierarchical name, assignment pattern, and string format specifications are described in 21.2.1.5 through 21.2.1.8.

The %t format specification works with the \$timeformat system task to specify a uniform time unit, time precision, and format for reporting timing information from various modules that use different time units and precisions. The \$timeformat task is described in 20.4.2.

For example:

```

module disp;
  logic [31:0] rval;
  pulldown (pd);
  initial begin
    rval = 101;
    $display("rval = %h hex %d decimal",rval,rval);
    $display("rval = %o octal\nrval = %b bin",rval,rval);
    $display("rval has %c ascii character value",rval);
    $display("pd strength value is %v",pd);
    $display("current scope is %m");
    $display("%s is ascii value for 101",101);
    $display("simulation time is %t", $time);
  end
endmodule

```

Simulating this example shall display the following:

```
rval = 00000065 hex          101 decimal
rval = 00000000145 octal
rval = 000000000000000000000000000000001100101 bin
rval has e ascii character value
pd strength value is StX
current scope is disp
e is ascii value for 101
simulation time is                0
```

21.2.1.3 Size of displayed data

For expression arguments, the values written to the output file (or terminal) are sized automatically.

For example, the result of a 12-bit expression would be allocated three characters when displayed in hexadecimal format and four characters when displayed in decimal format because the largest possible value for the expression is FFF (hexadecimal) and 4095 (decimal).

When displaying decimal values, leading zeros are suppressed and replaced by spaces. In other radices, leading zeros are always displayed.

The automatic sizing of displayed data can be overridden by inserting a field width between the % character and the letter that indicates the radix. The field width shall be a non-negative decimal integer constant. If the field width is 0, the result is displayed in the minimum width, with no leading spaces or zeros, as shown in the following example:

```
$display("d=%0h a=%0h", data, addr);
```

For example:

```
module printval;
  logic [11:0] r1;
  initial begin
    r1 = 10;
    $display( "Printing with maximum size - :%d: :%h:", r1,r1 );
    $display( "Printing with minimum size - :%0d: :%0h:", r1,r1 );
  end
endmodule
```

This example will print:

```
Printing with maximum size - : 10: :00a:
Printing with minimum size - :10: :a:
```

In this example, the result of a 12-bit expression is displayed. The first call to \$display uses the standard format specifier syntax and produces results requiring four and three columns for the decimal and hexadecimal radices, respectively. The second \$display call uses the %0 form of the format specifier syntax and produces results requiring two columns and one column, respectively.

If the value to be displayed has fewer characters than the field width, the field is padded on the left to the length specified by the field width. If the value is wider than the field width, the field is expanded to contain the converted result. Decimal and string values are expanded with leading spaces while hexadecimal, octal, and binary values use leading zeros. No truncation occurs.

Examples:

Format	Value	Displays
%d	32'd10	: 10:
%0d	32'd10	:10:
%h	32'd10	:0000000a:
%0h	32'd10	:a:
%3d	32'd5	: 5:
%3d	32'd100	:100:
%3d	32'd1234	:1234:
%3h	32'h5	:005:
%3h	32'h100	:100:
%3h	32'h1234	:1234:
%s	"abc"	:abc:
%3s	"a"	: a:
%3s	"abc"	:abc:
%3s	"abcdef"	:abcdef:

21.2.1.4 Unknown and high-impedance values

When the result of an expression contains an unknown or high-impedance value, certain rules apply to displaying that value.

In decimal (%d) format, the rules are as follows:

- If all bits are at the unknown value, a single lowercase *x* character is displayed.
- If all bits are at the high-impedance value, a single lowercase *z* character is displayed.
- If some, but not all, bits are at the unknown value, the uppercase *X* character is displayed.
- If some, but not all, bits are at the high-impedance value, the uppercase *Z* character is displayed, unless there are also some bits at the unknown value, in which case the uppercase *X* character is displayed.
- Decimal numerals always appear right-justified in a fixed-width field.

In hexadecimal (%h, %x) and octal (%o) formats, the rules are as follows:

- Each group of 4 bits is represented as a single hexadecimal digit; each group of 3 bits is represented as a single octal digit.
- If all bits in a group are at the unknown value, a lowercase *x* is displayed for that digit.
- If all bits in a group are at a high-impedance state, a lowercase *z* is printed for that digit.
- If some, but not all, bits in a group are unknown, an uppercase *X* is displayed for that digit.
- If some, but not all, bits in a group are at a high-impedance state, then an uppercase *Z* is displayed for that digit, unless there are also some bits at the unknown value, in which case an uppercase *X* is displayed for that digit.

In binary (%b) format, each bit is printed separately using the characters 0, 1, *x*, and *z*.

For example:

STATEMENT	RESULT
$\$display("%d", 1'bX);$	<i>x</i>
$\$display("%h", 14'bX01010);$	<i>xxXa</i>
$\$display("%h %o", 12'b001xxx101x01,$ $12'b001xxx101x01);$	<i>XXX 1x5X</i>

21.2.1.5 Strength format

The %v format specification is used to display the strength of scalar nets. For each %v specification that appears in a string, a corresponding scalar reference shall follow the string in the argument list.

The strength of a scalar net is reported in a three-character format. The first two characters indicate the strength. The third character indicates the current logic value of the scalar and can be any one of the values given in [Table 21-4](#).

Table 21-4—Logic value component of strength format

Argument	Description
0	For a logic 0 value
1	For a logic 1 value
X	For an unknown value
Z	For a high-impedance value
L	For a logic 0 or high-impedance value
H	For a logic 1 or high-impedance value

The first two characters—the strength characters—are either a two-letter mnemonic or a pair of decimal digits. Usually, a mnemonic is used to indicate strength information; however, in less typical cases, a pair of decimal digits can be used to indicate a range of strength levels. [Table 21-5](#) shows the mnemonics used to represent the various strength levels.

Table 21-5—Mnemonics for strength levels

Mnemonic	Strength name	Strength level
Su	Supply drive	7
St	Strong drive	6
Pu	Pull drive	5
La	Large capacitor	4
We	Weak drive	3
Me	Medium capacitor	2
Sm	Small capacitor	1
Hi	High impedance	0

There are four driving strengths and three charge storage strengths. The driving strengths are associated with gate outputs and continuous assignment outputs. The charge storage strengths are associated with the `tri-reg` type net. (See [Clause 28](#) for strength modeling.)

For the logic values 0 and 1, a mnemonic is used when there is no range of strengths in the signal. Otherwise, the logic value is preceded by two decimal digits, which indicate the maximum and minimum strength levels.

For the unknown value, a mnemonic is used when both the 0 and 1 strength components are at the same strength level. Otherwise, the unknown value x is preceded by two decimal digits, which indicate the 0 and 1 strength levels, respectively.

The high-impedance strength cannot have a known logic value; the only logic value allowed for this level is Z.

For the values L and H, a mnemonic is always used to indicate the strength level.

For example:

```
always
    #15 $display($time,, "group=%b signals=%v %v %v", {s1,s2,s3}, s1,s2,s3);
```

The example below shows the output that might result from such a call, while [Table 21-6](#) explains the various strength formats that appear in the output.

```
0 group=111 signals=St1 Pu1 St1
15 group=011 signals=Pu0 Pu1 St1
30 group=0xz signals=520 PuH HiZ
45 group=0xx signals=Pu0 65X StX
60 group=000 signals=Me0 St0 St0
```

Table 21-6—Explanation of strength formats

Argument	Description
St1	A strong driving 1 value
Pu0	A pull driving 0 value
HiZ	The high-impedance state
Me0	A 0 charge storage of medium capacitor strength
StX	A strong driving unknown value
PuH	A pull driving strength of 1 or high-impedance value
65X	An unknown value with a strong driving 0 component and a pull driving 1 component
520	An 0 value with a range of possible strength from pull driving to medium capacitor

21.2.1.6 Hierarchical name format

The %m format specifier does not accept an argument. Instead, it causes the display task to print the hierarchical name of the design element, subroutine, named block, or labeled statement that invokes the system task containing the format specifier. This is useful when there are many instances of the module that calls the system task. One obvious application is timing check messages in a flip-flop or latch module; the %m format specifier pinpoints the module instance responsible for generating the timing check message.

21.2.1.7 Assignment pattern format

The %p format specifier may be used to print aggregate expressions such as unpacked structures, arrays, and unions. For unpacked structure data types, it shall print the value as an assignment pattern with named elements. For unions, only the first declared elements shall be printed. In the case of a tagged union, it shall print “tag:value” along with the currently valid element. For unpacked array data types, it shall print the

value as an assignment pattern which may include the use of index labels. The use of white space is implementation dependent; however the output shall be a legal interpretation of the assignment pattern syntax (see [10.8](#)).

An unpacked data type is traversed until reaching a singular data type. Each element that is a singular type shall print its value as follows:

- A packed structure data type shall print its value as an assignment pattern with named elements. Each element shall be printed under one of these rules.
- An enumerated data type shall print its value as an enumeration name if the value is valid for that type. Otherwise the value shall print according to the base type of the enumeration.
- A string data type or string literal shall print its value as a string enclosed in quotes.
- A handle, class handle, event, or virtual interface shall print its value in an implementation dependent format, except that a null handle value shall print the word `null`.
- All other singular data types shall print their values as they would unformatted.

An implementation may use a “default” element to reduce its output and may set a limit on the maximum length of characters output, but that limit shall be at least 1024 characters. If that limit is reached, the output shall be truncated and a warning issued.

The `%p` format specifier may be used to print aggregate expressions such as unpacked structures, arrays, and unions in a shorter, implementation specific form. An implementation may set a limit on the maximum length of characters output as with `%p`.

The `%p` and `%0p` format specifiers can also be used to print singular expressions, in which case the expression is formatted as an element of an aggregate expression described above.

For example:

```
module top;
  typedef enum {ON, OFF} switch_e;
  typedef struct {switch_e sw; string s;} pair_t;
  pair_t va[int] = '{10: '{OFF, "switch10"}, 20: '{ON, "switch20"}';

  initial begin
    $display("va[int] = %p;", va);
    $display("va[int] = %0p;", va);
    $display("va[10].s = %p;", va[10].s);
  end
endmodule : top
```

This example may print:

```
va[int] = '{10: '{sw:OFF, s:"switch10"}, 20: '{sw:ON, s:"switch20"}' ;
va[int] = '{10: '{OFF, "switch10"}, 20: '{ON, "switch20"}' ;
va[10].s = "switch10";
```

21.2.1.8 String format

The `%s` format specifier is used to print ASCII codes as characters. For each `%s` specification that appears in a string, a corresponding argument shall follow the string in the argument list. The associated argument is interpreted as a sequence of 8-bit hexadecimal ASCII codes, with each 8 bits representing a single character. If the argument is a variable, its value should be right-justified so that the rightmost bit of the value is the least significant bit of the last character in the string. No termination character or value is required at the end of a string, and leading zeros are never printed.

The argument corresponding to a %s format specifier may also have a **string** type, or unpacked array of **byte** data types. Character ordering of the unpacked array is from left bound to right bound.

21.2.2 Strobed monitoring

The syntax for \$strobe system task is shown in [Syntax 21-2](#).

```
strobe_tasks ::=
    strobe_task_name [ ( list_of_arguments ) ] ;
strobe_task_name ::=
    $strobe | $strobeb | $stroboe | $strobeh
```

Syntax 21-2—Syntax for \$strobe system tasks (not in [Annex A](#))

The system task \$strobe provides the ability to display simulation data at a selected time. That time is the end of the current simulation time, when all the simulation events have occurred for that simulation time, just before simulation time is advanced. The arguments for this task are specified in exactly the same manner as for the \$display system task—including the use of escape sequences for special characters and format specifications (see [21.2.1](#)).

For example:

```
forever @(negedge clock)
    $strobe ("At time %d, data is %h", $time, data);
```

In this example, \$strobe writes the time and data information to the standard output and the log file at each negative edge of the clock. The action shall occur just before simulation time is advanced and after all other events at that time have occurred so that the data written are sure to be the correct data for that simulation time.

21.2.3 Continuous monitoring

The syntax for \$monitor system task is shown in [Syntax 21-3](#).

```
monitor_tasks ::=
    monitor_task_name [ ( list_of_arguments ) ] ;
    | $monitoron ;
    | $monitoroff ;
monitor_task_name ::=
    $monitor | $monitorb | $monitro | $monitorh
```

Syntax 21-3—Syntax for \$monitor system tasks (not in [Annex A](#))

The \$monitor task provides the ability to monitor and display the values of any variables or expressions specified as arguments to the task. The arguments for this task are specified in exactly the same manner as for the \$display system task—including the use of escape sequences for special characters and format specifications (see [21.2.1](#)).

When a \$monitor task is invoked with one or more arguments, the simulator sets up a mechanism whereby each time a variable or an expression in the argument list changes value—with the exception of the \$time, \$stime, or \$realtime system functions—the entire argument list is displayed at the end of the time step as

if reported by the `$display` task. If two or more arguments change value at the same time, only one display is produced that shows the new values.

Only one `$monitor` display list can be active at any one time; however, a new `$monitor` task with a new display list can be issued any number of times during simulation.

The `$monitoron` and `$monitoroff` tasks control a monitor flag that enables and disables the monitoring. Use `$monitoroff` to turn off the flag and disable monitoring. The `$monitoron` system task can be used to turn on the flag so that monitoring is enabled and the most recent call to `$monitor` can resume its display. A call to `$monitoron` shall produce a display immediately after it is invoked, regardless of whether a value change has taken place; this is used to establish the initial values at the beginning of a monitoring session. By default, the monitor flag is turned on at the beginning of simulation.

21.3 File input-output system tasks and system functions

The system tasks and system functions for file-based operations are divided into the following categories:

- System tasks and system functions that open and close files
- System tasks that output values into files
- System tasks that output values into variables
- System tasks and system functions that read values from files and load into variables or memories

21.3.1 Opening and closing files

The syntax for `$fopen` and `$fclose` system tasks is shown in [Syntax 21-4](#).

```
file_open_function ::=  
    multi_channel_descriptor = $fopen ( filename ) ;  
    | fd = $fopen ( filename , type ) ;  
file_close_task ::=  
    $fclose ( multi_channel_descriptor ) ;  
    | $fclose ( fd ) ;
```

Syntax 21-4—Syntax for `$fopen` and `$fclose` system tasks (not in [Annex A](#))

The function `$fopen` opens the file specified as the *filename* argument and returns either a 32-bit multichannel descriptor or a 32-bit file descriptor, determined by the absence or presence of the *type* argument.

filename is an expression that is a string literal, `string` data type, or an integral data type containing a character string that names the file to be opened.

type is an expression that is a string literal, `string` data type, or an integral data type containing a character string of one of the forms in [Table 21-7](#) that indicates how the file should be opened. If *type* is omitted, the file is opened for writing, and a multichannel descriptor *mcd* is returned. If *type* is supplied, the file is opened as specified by the value of *type*, and a file descriptor *fd* is returned.

Table 21-7—Types for file descriptors

Argument	Description
"r" or "rb"	Open for reading
"w" or "wb"	Truncate to zero length or create for writing
"a" or "ab"	Append; open for writing at end of file (EOF), or create for writing
"r+", "r+b", or "rb+"	Open for update (reading and writing)
"w+", "w+b", or "wb+"	Truncate or create for update
"a+", "a+b", or "ab+"	Append; open or create for update at EOF

The multichannel descriptor *mcd* is a 32-bit packed array value in which a single bit is set indicating which file is opened. The least significant bit (bit 0) of an *mcd* always refers to the standard output. Output is directed to two or more files opened with multichannel descriptors by bitwise OR-ing together their *mcd*s and writing to the resultant value.

The most significant bit (bit 31) of a multichannel descriptor is reserved and shall always be cleared, limiting an implementation to at most 31 files opened for output via multichannel descriptors.

The file descriptor *fd* is a 32-bit packed array value. The most significant bit (bit 31) of a *fd* is reserved and shall always be set; this allows implementations of the file input and output functions to determine how the file was opened. The remaining bits hold a small number indicating what file is opened. Three file descriptors are pre-opened; they are **STDIN**, **STDOUT**, and **STDERR**, which have the values `32'h8000_0000`, `32'h8000_0001`, and `32'h8000_0002`, respectively. **STDIN** is pre-opened for reading, and **STDOUT** and **STDERR** are pre-opened for append.

Unlike multichannel descriptors, file descriptors cannot be combined via bitwise OR in order to direct output to multiple files. Instead, files are opened via file descriptor for input, output, and both input and output, as well as for append operations, based on the value of *type*, according to [Table 21-7](#).

If a file cannot be opened (either the file does not exist and the *type* specified is "r", "rb", "r+", "r+b", or "rb+", or the permissions do not allow the file to be opened at that path), a zero is returned for the *mcd* or *fd*. Applications can call `$ferror` to determine the cause of the most recent error (see [21.3.7](#)).

The "b" in the above types exists to distinguish binary files from text files. Many systems make no distinction between binary and text files, and on these systems the "b" is ignored. However, some systems perform data mappings on certain binary values written to and read from files that are opened for text access.

The `$fclose` system task closes the file specified by *fd* or closes the file(s) specified by the multichannel descriptor *mcd*. No further output to or input from any file descriptor(s) closed by `$fclose` is allowed. Active `$fmonitor` and/or `$fstrobe` operations on a file descriptor or multichannel descriptor are implicitly cancelled by an `$fclose` operation. The `$fopen` function shall reuse channels that have been closed.

NOTE—The number of simultaneous input and output channels that can be open at any one time is dependent on the operating system. Some operating systems do not support opening files for update.

21.3.2 File output system tasks

The syntax for `$fdisplay`, `$fwrite`, `$fmonitor`, and `$fstrobe` system tasks is shown in [Syntax 21-5](#).

```

file_output_tasks ::=
    file_output_task_name ( multi_channel_descriptor [ , list_of_arguments ] ) ;
    | file_output_task_name ( fd [ , list_of_arguments ] ) ;
file_output_task_name ::=
    $fdisplay | $fdisplayb | $fdisplayh | $fdisplayo
    | $fwrite | $fwriteb | $fwriteh | $fwriteo
    | $fstrobe | $fstrobeb | $fstrobeh | $fstrobeo
    | $fmonitor | $fmonitorb | $fmonitorh | $fmonitoro

```

Syntax 21-5—Syntax for file output system tasks (not in [Annex A](#))

Each of the four formatted display tasks—`$display`, `$write`, `$monitor`, and `$strobe`—has a counterpart that writes to specific files as opposed to the standard output. These counterpart tasks—`$fdisplay`, `$fwrite`, `$fmonitor`, and `$fstrobe`—accept the same type of arguments as the tasks upon which they are based, with one exception: The first argument shall be either a multichannel descriptor or a file descriptor, which indicates where to direct the file output. Multichannel descriptors are described in detail in [21.3.1](#). A multichannel descriptor is either a variable or the result of an expression that takes the form of a 32-bit unsigned integer value.

The `$fstrobe` and `$fmonitor` system tasks work just like their counterparts, `$strobe` and `$monitor`, except that they write to files using the multichannel descriptor for control. Unlike `$monitor`, any number of `$fmonitor` tasks can be set up to be simultaneously active. However, there is no counterpart to `$monitoron` and `$monitroff` tasks. The task `$fclose` is used to cancel an active `$fstrobe` or `$fmonitor` task.

The following example shows how to set up multichannel descriptors. In this example, three different channels are opened using the `$fopen` function. The three multichannel descriptors that are returned by the function are then combined in a bitwise OR operation and assigned to the integer variable `messages`. The `messages` variable can then be used as the first argument in a file output task to direct output to all three channels at once. To create a descriptor that directs output to the standard output as well, the `messages` variable is a bitwise OR with the constant 1, which effectively enables channel 0.

```

integer
    messages, broadcast,
    cpu_chann, alu_chann, mem_chann;
initial begin
    cpu_chann = $fopen("cpu.dat");
    if (cpu_chann == 0) $finish;
    alu_chann = $fopen("alu.dat");
    if (alu_chann == 0) $finish;
    mem_chann = $fopen("mem.dat");
    if (mem_chann == 0) $finish;
    messages = cpu_chann | alu_chann | mem_chann;
    // broadcast includes standard output
    broadcast = 1 | messages;
end
endmodule

```

The following file output tasks show how the channels opened in the preceding example might be used:

```

$fdisplay( broadcast, "system reset at time %d", $time );

$fdisplay( messages, "Error occurred on address bus",

```

```

    " at time %d, address = %h", $time, address );

    forever @(posedge clock)
        $fdisplay( alu_chann, "acc= %h f=%h a=%h b=%h", acc, f, a, b );

```

21.3.3 Formatting data to a string

The syntax for the `$swrite` family of tasks and for `$sformat` system task is shown in [Syntax 21-6](#).

```

string_output_tasks ::=
    string_output_task_name ( output_var [ , list_of_arguments ] ) ;
string_output_task_name ::=
    $swrite | $swriteb | $swriteh | $swriteo
variable_format_string_output_task ::=
    $sformat ( output_var , format_string [ , list_of_arguments ] ) ;
variable_format_string_output_function ::=
    $sformatf ( format_string [ , list_of_arguments ] )

```

Syntax 21-6—Syntax for formatting data tasks (not in [Annex A](#))

The `$swrite` family of tasks is based on the `$fwrite` family of tasks and accepts the same type of arguments as the tasks upon which it is based, with one exception: The first argument to `$swrite` shall be a variable of integral, unpacked array of **byte**, or **string** data types to which the resulting string shall be written, instead of a variable specifying the file to which to write the resulting string. Character ordering of the unpacked array is from left bound to right bound.

The system task `$sformat` is similar to the system task `$swrite`, with one major difference. Unlike the display and write family of output system tasks, `$sformat` always interprets its second argument, and only its second argument, as a format string. This format argument can be a string literal, such as "data is %d", or may be an expression of integral, unpacked array of byte, or **string** data types whose content is interpreted as the formatting string. No other arguments are interpreted as format strings. `$sformat` supports all the format specifiers supported by `$display`, as documented in [21.2.1.2](#).

The remaining arguments to `$sformat`, if any, are processed using any format specifiers in the *format_string*, until all such format specifiers are used up. If not enough arguments are supplied for the format specifiers or too many are supplied, then the application shall issue a warning and continue execution. The application, if possible, can statically determine a mismatch in format specifiers and number of arguments and issue a compile time error message.

NOTE—If the *format_string* is a not a constant expression, it might not be possible to determine its value at compile time.

The variable *output_var* is assigned using the string literal assignment to variable rules, as specified in [11.10](#).

The system function `$sformatf` behaves like `$sformat` except that the string result is passed back as the function result value for `$sformatf`, not placed in the first argument as for `$sformat`. Thus `$sformatf` can be used where a string value would be valid.

21.3.4 Reading data from a file

```
file_read_functions ::=  
    $fgetc ( fd )  
    | $ungetc ( c , fd )  
    | $fgets ( str , fd )  
    | $fscanf ( fd , format , args )  
    | $sscanf ( str , format , args )  
    | $fread ( integral_var , fd )  
    | $fread ( mem , fd [ , [ start ] [ , count ] ] )
```

Syntax 21-7—Syntax for file read system functions (not in [Annex A](#))

Files opened using file descriptors (*fd*) can be read from only if they were opened with either the *r* or *r+* *type* values. See [21.3.1](#) for more information about opening files.

21.3.4.1 Reading a character at a time

A single character can be read from a file using `$fgetc`. For example:

Example 1:

```
integer c;  
c = $fgetc ( fd );
```

reads a byte from the file specified by *fd*. If an error occurs reading from the file, then *c* is set to `EOF` (-1). The code defines the width of variable *c* to be wider than 8 bits so that a return value from `$fgetc` of `EOF` (-1) can be differentiated from the character code `0xFF`. Applications can call `$ferror` to determine the cause of the most recent error (see [21.3.7](#)).

Example 2:

```
integer code;  
code = $ungetc ( c, fd );
```

inserts the character specified by *c* into the buffer specified by file descriptor *fd*. The character *c* shall be returned by the next `$fgetc` call on that file descriptor. The file itself is unchanged. If an error occurs pushing a character onto a file descriptor, then *code* is set to `EOF`. Otherwise, *code* is set to zero. Applications can call `$ferror` to determine the cause of the most recent error (see [21.3.7](#)).

NOTE—The features of the underlying implementation of file I/O on the host system limit the number of characters that can be pushed back onto a stream. Operations like `$fseek` might erase any pushed back characters.

21.3.4.2 Reading a line at a time

One line can be read from a file using `$fgets`. For example:

```
integer code;  
code = $fgets ( str, fd );
```

reads characters from the file specified by *fd* into the variable *str* until *str* is filled, or a newline character is read and transferred to *str*, or an `EOF` condition is encountered. If *str* is not an integral number of bytes in length, the most significant partial byte is not used in order to determine the size.

If an error occurs reading from the file, then `code` is set to zero. Otherwise, the number of characters read is returned in `code`. Applications can call `$ferror` to determine the cause of the most recent error (see [21.3.7](#)).

21.3.4.3 Reading formatted data

The `$fscanf` system function can be used to format data as it is read from a file. For example:

```
integer code ;
code = $fscanf ( fd, format, args );
code = $sscanf ( str, format, args );
```

`$fscanf` reads from the files specified by the file descriptor `fd`.

`$sscanf` reads from the argument `str`, which may be an expression of integral, unpacked array of byte, or **string** data type.

Both functions read characters, interpret them according to a format, and store the results. Both expect as arguments a control string, `format`, and a set of arguments specifying where to place the results. If there are insufficient arguments for the format, the behavior is undefined. If the format is exhausted while arguments remain, the excess arguments are ignored.

If an argument is too small to hold the converted input, then, in general, the least significant bits are transferred. Arguments of any length that is supported by SystemVerilog can be used. However, if the destination is a **real**, **shortreal**, or **realtime**, then the value `+Inf` (or `-Inf`) is transferred. The format can be an expression containing a string, **string** data type, or an integral data type. The string contains conversion specifications, which direct the conversion of input into the arguments. The control string can contain the following:

- a) White space characters (blanks, tabs, newlines, or formfeeds) that, except in one case described below, cause input to be read up to the next nonwhite space character. For `$sscanf`, null characters shall also be considered white space.
- b) An ordinary character (not `%`) that shall match the next character of the input stream.
- c) Conversion specifications consisting of the character `%`, an optional assignment suppression character `*`, a decimal digit string that specifies an optional numerical maximum field width, and a conversion code.

A conversion specification directs the conversion of the next input field; the result is placed in the variable specified in the corresponding argument unless assignment suppression was indicated by the character `*`. In this case, no argument shall be supplied.

The suppression of assignment provides a way of describing an input field that is to be skipped. An *input field* is defined as a string of nonspace characters; it extends to the next inappropriate character or until the maximum field width, if one is specified, is exhausted. For all descriptors except the character `c`, white space leading an input field is ignored. [Table 21-8](#) describes the input field characters for `$fscanf`.

Table 21-8—\$fscanf input field characters

Input Field	Description
<code>%</code>	A single <code>%</code> is expected in the input at this point; no assignment is done.
<code>b</code>	Matches a binary number, consisting of a sequence from the set <code>0,1,X,x,Z,z,?,</code> and <code>_</code> .

Table 21-8—\$fscanf input field characters (continued)

Input Field	Description
o	Matches a octal number, consisting of a sequence of characters from the set 0,1,2,3,4,5,6,7,X,x,Z,z,?, and _.
d	Matches an optionally signed decimal number, consisting of the optional sign from the set + or -, followed by a sequence of characters from the set 0,1,2,3,4,5,6,7,8,9, and _, or a single value from the set x,X,z,Z,?.
h or x	Matches a hexadecimal number, consisting of a sequence of characters from the set 0,1,2,3,4,5,6,7,8,9,a,A,b,B,c,C,d,D,e,E,f,F,x,X,z,Z,?, and _.
f, e, or g	Matches a floating point number. The format of a floating point number is an optional sign (either + or -), followed by a string of digits from the set 0,1,2,3,4,5,6,7,8,9 optionally containing a decimal point character (.), followed by an optional exponent part including e or E, followed by an optional sign, followed by a string of digits from the set 0,1,2,3,4,5,6,7,8,9.
v	Matches a net signal strength, consisting of a three-character sequence as specified in 21.2.1.5. This conversion is not extremely useful, as strength values are really only usefully assigned to nets and \$fscanf can only assign values to integral variables (if assigned to integral variables, the values are converted to the 4 value equivalent).
t	Matches a floating point number. The format of a floating point number is an optional sign (either + or -), followed by a string of digits from the set 0,1,2,3,4,5,6,7,8,9 optionally containing a decimal point character (.), followed by an optional exponent part including e or E, followed by an optional sign, followed by a string of digits from the set 0,1,2,3,4,5,6,7,8,9. The value matched is then scaled and rounded according to the current timescale as set by \$timeformat. For example, if the timescale is `timescale 1ns/100ps and the time format is \$timeformat(-3,2," ms",10);, then a value read with \$\$scanf("10.345", "%t", t) would return 10350000.0.
c	Matches a single character, whose 8-bit ASCII value is returned.
s	Matches a string, which is a sequence of nonwhite space characters.
u	<p>Matches unformatted (binary) data. The application shall transfer sufficient data from the input to fill the target variable. Typically, the data are obtained from a matching \$fwrite ("%u",data) or from an external application written in another programming language such as C, Perl, or FORTRAN.</p> <p>The application shall transfer the 2 value binary data from the input stream to the destination variable, expanding the data to the 4 value format. This escape sequence can be used with any of the existing input system tasks, although \$fscanf should be the preferred one to use. As the input data cannot represent x or z, it is not possible to obtain an x or z in the result variable. This formatting specifier is intended to be used to support transferring data to and from external programs that have no concept of x and z.</p> <p>Applications that require preservation of x and z are encouraged to use the %z I/O format specification.</p> <p>The data shall be read from the file in the native endian format of the underlying system (i.e., in the same endian order as if the PLI was used and the C language read(2) system call was used).</p> <p>For POSIX applications, it might be necessary to open files for unformatted I/O with the "rb", "rb+", or "r+b" specifiers to avoid the systems implementation of I/O altering patterns in the unformatted stream that match special characters.</p>

Table 21-8—\$fscanf input field characters (continued)

Input Field	Description
z	<p>The formatting specification %z (or %Z) is defined for reading data without formatting (binary values). The application shall transfer the 4 value binary representation of the specified data from the input stream to the destination variable. This escape sequence can be used with any of the existing input system tasks, although \$fscanf should be the preferred one to use.</p> <p>This formatting specifier is intended to be used to support transferring data to and from external programs that recognize and support the concept of x and z. Applications that do not require the preservation of x and z are encouraged to use the %u I/O format specification.</p> <p>The data shall be read from the file in the native endian format of the underlying system (i.e., in the same endian order as if the PLI was used, the data were in a s_vpi_vecval structure (see Figure 38-8 in 38.15), and the C language read(2) system call was used to read the data from disk).</p> <p>For POSIX applications, it might be necessary to open files for unformatted I/O with the "rb", "rb+", or "r+b" specifiers to avoid the systems implementation of I/O altering patterns in the unformatted stream that match special characters.</p>
m	<p>Returns the current hierarchical path as a string. Does not read data from the input file or str argument.</p>

The integer format specifiers, %h (or %H), %d (or %D), %o (or %O), %b (or %B), %c (or %C), %u (or %U), and %z (or %Z), may be used to read into any of the integral data types, including enumerated data types and packed aggregate data types. These format specifiers can also be used with user-defined data types that have been defined (using `typedef`) to be represented using one of these basic types. They shall not be used with any unpacked aggregate data type.

The string format specifier %s (or %S) may be used to read into a variable of integral, unpacked array of `byte`, or `string` data types.

If an invalid conversion character follows the %, the results of the operation are implementation dependent.

If the format string or the `str` argument to `$sscanf` contains unknown bits (x or z), then the system function shall return `EOF (-1)`.

If `EOF` is encountered during input, conversion is terminated. If `EOF` occurs before any characters matching the current directive have been read (other than leading white space, where permitted), execution of the current directive terminates with an input failure. Otherwise, unless execution of the current directive is terminated with a matching failure, execution of the following directive (if any) is terminated with an input failure.

If conversion terminates on a conflicting input character, the offending input character is left unread in the input stream. Trailing white space (including newline characters) is left unread unless matched by a directive. The success of literal matches and suppressed assignments is not directly determinable.

The number of successfully matched and assigned input items is returned in `code`; this number can be 0 in the event of an early matching failure between an input character and the control string. If the input ends before the first matching failure or conversion, `EOF (-1)` is returned. Applications can call `$ferror` to determine the cause of the most recent error (see [21.3.7](#)).

21.3.4.4 Reading binary data

`$fread` can be used to read binary data from a file. For example:

```
integer code ;  
code = $fread( integral_var, fd);  
code = $fread( mem, fd);  
code = $fread( mem, fd, start);  
code = $fread( mem, fd, start, count);  
code = $fread( mem, fd, , count);
```

read binary data from the file specified by `fd` into the variable `integral_var` or the memory `mem`.

The integral variable variant,

```
$fread(integral_var, fd);
```

is defined to be the one applied for all packed data.

`start` is an optional argument. If present, `start` shall be used as the address of the first element in the memory to be loaded. If not present, the lowest numbered location in the memory shall be used.

`count` is an optional argument. If present, `count` shall be the maximum number of locations in `mem` that shall be loaded. If not supplied, the memory shall be filled with what data are available.

`start` and `count` are ignored if `$fread` is loading an integral variable.

If no addressing information is specified within the system task and no address specifications appear within the data file, then the default start address is the lowest address given in the declaration of the memory. Consecutive words are loaded toward the highest address until either the memory is full or the data file is completely read. If the start address is specified in the task without the finish address, then loading starts at the specified start address and continues toward the highest address given in the declaration of the memory.

`start` is the address in the memory. For `start = 12` and the memory `up[10:20]`, the first data would be loaded at `up[12]`. For the memory `down[20:10]`, the first location loaded would be `down[12]`, then `down[13]`.

The data in the file shall be read byte by byte to fulfill the request. An 8-bit wide memory is loaded using 1 byte per memory word, while a 9-bit wide memory is loaded using 2 bytes per memory word. The data are read from the file in a big endian manner; the first byte read is used to fill the most significant location in the memory element. If the memory width is not evenly divisible by 8 (8, 16, 24, 32), not all data in the file are loaded into memory because of truncation.

For unpacked **struct** data, `$fread` is defined to apply as though the operation were performed on each member in declaration order.

For unpacked **union** data, `$fread` is defined to apply as though the operation were performed on the first member in declaration order.

The data loaded from the file are taken as 2 value data. A bit set in the data is interpreted as a 1, and bit not set is interpreted as a 0. It is not possible to read a value of `x` or `z` using `$fread`.

If an error occurs reading from the file, then `code` is set to zero. Otherwise, the number of characters read is returned in `code`. Applications can call `$ferror` to determine the cause of the most recent error (see [21.3.7](#)).

NOTE—There is not a “binary” mode and an “ASCII” mode; one can freely intermingle binary and formatted read commands from the same file.

21.3.5 File positioning

```
file_positioning_functions ::=
    $ftell ( fd )
    | $fseek ( fd , offset , operation )
    | $frewind ( fd )
```

Syntax 21-8—Syntax for file positioning system functions (not in [Annex A](#))

`$ftell` is used to determine the current read or write position within a file. For example:

```
integer pos ;
pos = $ftell ( fd );
```

returns in `pos` the offset from the beginning of the file of the current byte of the file `fd`, which shall be read or written by a subsequent operation on that file descriptor.

This value can be used by subsequent `$fseek` calls to reposition the file to this point. Any repositioning shall cancel any `$ungetc` operations. If an error occurs, EOF (-1) is returned. Applications can call `$ferror` to determine the cause of the most recent error (see [21.3.7](#)).

`$fseek` and `$frewind` can be used to change the current read or write position within a file. For example:

```
integer code ;
code = $fseek ( fd , offset , operation );
code = $frewind ( fd );
```

sets the position of the next input or output operation on the file specified by `fd`. The new position is at the signed distance offset bytes from the beginning, from the current position, or from the end of the file, according to an operation value of 0, 1, and 2, as follows:

- 0 sets position equal to offset bytes
- 1 sets position to current location plus offset
- 2 sets position to EOF plus offset

`$frewind` is equivalent to `$fseek (fd,0,0)`;

Repositioning the current file position with `$fseek` or `$frewind` shall cancel any `$ungetc` operations.

`$fseek()` allows the file position indicator to be set beyond the end of the existing data in the file. If data are later written at this point, subsequent reads of data in the gap shall return zero until data are actually written into the gap. `$fseek`, by itself, does not extend the size of the file.

When a file is opened for append (that is, when type is "a" or "a+"), it is impossible to overwrite information already in the file. `$fseek` can be used to reposition the file pointer to any position in the file, but when output is written to the file, the current file pointer is disregarded. All output is written at the end of the file and causes the file pointer to be repositioned at the end of the output.

If an error occurs repositioning the file, then code is set to -1. Otherwise, code is set to 0. Applications can call `$ferror` to determine the cause of the most recent error (see [21.3.7](#)).

21.3.6 Flushing output

```
file_flush_task ::=  
    $fflush ( [ mcd | fd ] ) ;
```

Syntax 21-9—Syntax for file flush system task (not in [Annex A](#))

The file I/O buffer can be flushed used `$fflush`. For example:

```
$fflush ( mcd );  
$fflush ( fd );  
$fflush ( );
```

writes any buffered output to the file(s) specified by `mcd`, to the file specified by `fd`, or if `$fflush` is invoked with no arguments, to all open files.

21.3.7 I/O error status

```
file_error_detect_function ::=  
    $ferror ( fd , str )
```

Syntax 21-10—Syntax for file I/O error detection system function (not in [Annex A](#))

Should any error be detected by one of the file I/O routines, an error code is returned. Often this is sufficient for normal operation (i.e., if the opening of an optional configuration file fails, the application typically would simply continue using default values). However, sometimes it is useful to obtain more information about the error for correct application operation. In this case, the `$ferror` function can be used:

```
integer errno ;  
errno = $ferror ( fd, str );
```

A string description of the type of error encountered by the most recent file I/O operation is written into the variable `str`, which should be a packed array of at least 640 bits wide or a **string** type. The integral value of the error code is returned in `errno`. If the most recent operation did not result in an error, then the value returned shall be zero, and the `str` variable shall be cleared.

21.3.8 Detecting EOF

```
file_eof_detect_function ::=  
    $feof ( fd )
```

Syntax 21-11—Syntax for end-of-file file detection system function (not in [Annex A](#))

End of file can be tested for using `$feof`. For example:

```
integer code;  
code = $feof ( fd );
```

returns a nonzero value when EOF has previously been detected reading the input file *fd*. It returns zero otherwise.

21.4 Loading memory array data from a file

Two system tasks—`$readmemb` and `$readmemh`—read and load data from a specified text file into a specified memory array (see [7.4.4](#)). The syntax for `$readmemb` and `$readmemh` system tasks is shown in [Syntax 21-12](#).

```
load_memory_tasks ::=
    $readmemb ( filename , memory_name [ , start_addr [ , finish_addr ] ] ) ;
  | $readmemh ( filename , memory_name [ , start_addr [ , finish_addr ] ] ) ;
```

Syntax 21-12—Syntax for memory load system tasks (not in [Annex A](#))

The *filename* is an expression that is a string literal, **string** data type, or an integral data type containing a character string that names the file to be opened.

The *memory_name* can be an unpacked array or a partially indexed multidimensional unpacked array that resolves to a lesser dimensioned unpacked array (see [21.4.3](#)). Higher order dimensions shall be specified with an index, rather than a complete or partial dimension range. The lowest dimension (i.e., the rightmost specified dimension in the identifier) can be specified with slice syntax. See [7.4.6](#) for details on legal array indexing in SystemVerilog.

The *start_addr* and *finish_addr* arguments apply to the addresses of the unpacked array selected by *memory_name*. This address range represents the highest dimension of data in the *filename*.

When slice syntax is used in the *memory_name* argument, any *start_addr* and *finish_addr* arguments shall fall within the bounds of the slice's range.

The direction of the highest dimension's file entries is given by the relative magnitudes of *start_addr* and *finish_addr*.

These tasks can be executed at any time during simulation.

The text file to be read shall contain only the following:

- White space (spaces, newlines, tabs, and formfeeds)
- Comments (both types of comment are allowed)
- Binary or hexadecimal numbers

The numbers shall have neither the length nor the base format specified. For `$readmemb`, each number shall be binary. For `$readmemh`, the numbers shall be hexadecimal. The unknown value (`x` or `X`), the high-impedance value (`z` or `Z`), and the underscore (`_`) can be used in specifying a number as in a SystemVerilog source description. White space and/or comments shall be used to separate the numbers.

In the following discussion, the term *address* refers to an index into the array that models the memory.

As the file is read, each number encountered is assigned to a successive word element of the memory. Addressing is controlled both by specifying start and/or finish addresses in the system task invocation and by specifying addresses in the data file.

When addresses appear in the data file, the format is an at character (@) followed by a hexadecimal number, as follows:

```
@hh...h
```

Both uppercase and lowercase digits are allowed in the number. No white space is allowed between the @ and the number. As many address specifications as needed within the data file can be used. When the system task encounters an address specification, it loads subsequent data starting at that memory address.

If no addressing information is specified within the system task and no address specifications appear within the data file, then the default start address shall be the lowest address in the memory. Consecutive words shall be loaded until either the highest address in the memory is reached or the data file is completely read. If the start address is specified in the task without the finish address, then loading shall start at the specified start address and shall continue upward toward the highest address in the memory. In both cases, loading shall continue upward even after an address specification in the data file.

If both start and finish addresses are specified as arguments to the task, then loading shall begin at the start address and shall continue toward the finish address. If the start address is greater than the finish address, then the address will be decremented between consecutive loads rather than being incremented. Loading shall continue to follow this direction even after an address specification in the data file.

When addressing information is specified both in the system task and in the data file, the addresses in the data file shall be within the address range specified by the system task arguments; otherwise, an error message is issued, and the load operation is terminated.

A warning shall be issued if the number of data words in the file differs from the number of words in the range implied by the start through finish addresses and no address specifications appear within the data file. In this case, the data words that are contained in the file shall be loaded into the memory beginning at the start address, and memory addresses for which the file does not contain data words are not modified by the operation.

For example:

```
logic [7:0] mem[1:256];
```

Given this declaration, each of the following statements load data into `mem` in a different manner:

```
initial $readmemb("mem.data", mem);  
initial $readmemb("mem.data", mem, 16);  
initial $readmemb("mem.data", mem, 128, 1);
```

The first statement loads up the memory at simulation time 0 starting at the memory address 1. The second statement begins loading at address 16 and continue on toward address 256. For the third and final statement, loading begins at address 128 and continue down toward address 1.

In the third case, when loading is complete, a final check is performed to verify that exactly 128 numbers are contained in the file. If the check fails, a warning is issued.

21.4.1 Reading packed data

`$readmemb` and `$readmemh` support unpacked arrays of packed data. In such cases, the system tasks treat each packed element as the vector equivalent and perform the normal operation.

When loading dynamic arrays and queues, the current size of the array is fixed; the array shall not be resized.

When loading associative arrays, indices shall be of integral types. Loading an address creates an element of that index, if it does not already exist. When an associative array's index is of an enumerated type, address entries in the pattern file are in numeric format and correspond to the numeric values associated with the elements of the enumerated type.

21.4.2 Reading 2-state types

`$readmemb` and `$readmemh` support packed data of 2-state types, such as `int` or enumerated types. For 2-state integer types, reading proceeds the same as for 4-state variable types (e.g., integer), with the exception that `x` or `z` data are converted to 0. For enumerated types, the file data represents the numeric values associated with each element of the enumerated type (see 6.19). If a numeric value is out of range for a given type, then an error shall be issued and no further reading shall take place.

21.4.3 File format considerations for multidimensional unpacked arrays

The `$readmemb` and `$readmemh` system tasks (and the `$writememb` and `$writememh` tasks) can work with multidimensional unpacked arrays.

The file contents are organized in row-major order, with each dimension's entries ranging from low to high address. This is backward compatible with one-dimensional memory arrays.

In this organization, the lowest dimension (i.e., the rightmost dimension in the array declaration) varies the most rapidly. There is a hierarchical sense to the file data. The higher dimensions contain words of lower dimension data, sorted in row-major order. Each successive lower dimension is entirely enclosed as part of higher dimension words.

As an example of file format organization, here is the layout of a file representing words for a memory declared:

```
logic [31:0] mem [0:2][0:4][5:8];
```

In the example word contents, `wzyx`,

- `z` corresponds to words of the `[0:2]` dimension.
- `y` corresponds to words of the `[0:4]` dimension.
- `x` corresponds to words of the `[5:8]` dimension.

```

w005 w006 w007 w008
w015 w016 w017 w018
w025 w026 w027 w028
w035 w036 w037 w038
w045 w046 w047 w048
w105 w106 w107 w108
w115 w116 w117 w118
w125 w126 w127 w128
w135 w136 w137 w138
w145 w146 w147 w148
w205 w206 w207 w208
w215 w216 w217 w218
w225 w226 w227 w228
w235 w236 w237 w238
w245 w246 w247 w248

```

The above diagram would be identical if one or more of the unpacked dimension declarations were reversed, as in the following:

```
logic [31:0] mem [2:0][0:4][8:5]
```

Address entries in the file exclusively address the highest dimension's words. In the above case, address entries in the file could look something as follows:

```
@0 w005 w006 w007 w008
    w015 w016 w017 w018
    w025 w026 w027 w028
    w035 w036 w037 w038
    w045 w046 w047 w048
@1 w105 w106 w107 w108
    w115 w116 w117 w118
    w125 w126 w127 w128
    w135 w136 w137 w138
    w145 w146 w147 w148
@2 w205 w206 w207 w208
    w215 w216 w217 w218
    w225 w226 w227 w228
    w235 w236 w237 w238
    w245 w246 w247 w248
```

When `$readmemb` or `$readmemb` is given a file without address entries, all data are read assuming that each dimension has complete data. i.e., each word in each dimension will be initialized with the appropriate value from the file. If the file contains incomplete data, the read operation will stop at the last initialized word, and any remaining array words or subwords will be left unchanged.

When `$readmemb` or `$readmemb` is given a file with address entries, initialization of the specified highest dimension words is done. If the file contains insufficient words to completely fill a highest dimension word, then the remaining subwords are left unchanged.

When a memory contains multiple packed dimensions, the memory words in the pattern file are composed of the sum total of all bits in the packed dimensions. The layout of packed bits in packed dimensions is defined in [7.4.5](#).

21.5 Writing memory array data to a file

The `$writememb` and `$writememb` system tasks can be used to dump memory array (see [7.4.4](#)) contents to files that are readable by `$readmemb` and `$readmemb`, respectively.

```
writemem_tasks ::=
    $writememb ( filename , memory_name [ , start_addr [ , finish_addr ] ] ) ;
| $writememb ( filename , memory_name [ , start_addr [ , finish_addr ] ] ) ;
```

Syntax 21-13—Writemem system task syntax (not in [Annex A](#))

If `filename` exists at the time `$writememb` or `$writememb` is called, the file will be overwritten (i.e., there is no append mode).

21.5.1 Writing packed data

`$writememb` and `$writememb` treat packed data identically to `$readmemb` and `$readmemb`. See [21.4.1](#).

21.5.2 Writing 2-state types

`$writememb` and `$writememh` can write out data corresponding to unpacked arrays of 2-state types, such as `int` or enumerated types. For enumerated types, values in the file correspond to the ordinal values of the enumerated type (see [6.19](#)).

21.5.3 Writing addresses to output file

When `$writememb` and `$writememh` write out data corresponding to unpacked or dynamic arrays, address specifiers (@-words) shall not be written to the output file.

When `$writememb` and `$writememh` write out data corresponding to associative arrays, address specifiers shall be written to the output file. As specified in [21.4.1](#), associative arrays shall have indices of integral types in order to be legal arguments to the `$writememb` and `$writememh` calls.

21.6 Command line input

An alternative to reading a file to obtain information for use in the simulation is specifying information with the command to invoke the simulator. This information is in the form of an optional argument provided to the simulation. These arguments are visually distinguished from other simulator arguments by their starting with the plus (+) character.

These arguments, referred to below as *plusargs*, are accessible through the system functions:

```
$test$plusargs ( string )
$value$plusargs ( user_string, variable )
```

The `$test$plusargs` system function searches the list of *plusargs* for a user specified *plusarg_string*. The string is specified in the argument to the system function as either a string or a integral variable that is interpreted as a string. If a variable is used to specify the string, leading nulls in the variable shall be ignored and shall not be considered as part of the matching string. This string shall not include the leading plus sign of the command line argument. The *plusargs* present on the command line are searched in the order provided. If the prefix of one of the supplied *plusargs* matches all characters in the provided string, the function returns a nonzero integer. If no *plusarg* from the command line matches the string provided, the function returns the integer value zero.

For example:

Run simulator with command: +HELLO

```
initial begin
  if ($test$plusargs("HELLO")) $display("Hello argument found.");
  if ($test$plusargs("HE")) $display("The HE subset string is detected.");
  if ($test$plusargs("H")) $display("Argument starting with H found.");
  if ($test$plusargs("HELLO_HERE")) $display("Long argument.");
  if ($test$plusargs("HI")) $display("Simple greeting.");
  if ($test$plusargs("LO")) $display("Does not match.");
end
```

This code would produce the following output:

```
Hello argument found.
The HE subset string is detected.
Argument starting with H found.
```

The `$value$plusargs` system function searches the list of *plusargs* (like the `$test$plusargs` system function) for a user-specified *plusarg_string*. The string is specified in the first argument to the system function as either a string or an integral variable that is interpreted as a string. If a variable is used to specify the string, leading nulls in the variable shall be ignored and shall not be considered as part of the matching string. This string shall not include the leading plus sign of the command line argument. The *plusargs* present on the command line are searched in the order provided. If the prefix of one of the supplied *plusargs* matches all characters in the provided string, the function returns a nonzero integer, the remainder of the string is converted to the type specified in the *user_string*, and the resulting value is stored in the variable provided. If no string is found matching, the function returns the integer value zero, and the variable provided is not modified. No warnings shall be generated when the function returns zero (0).

The *user_string* shall be of the following form: "*plusarg_string format_string*". The format strings are the same as the `$display` system tasks. These are the only valid ones (uppercase and lowercase as well as leading 0 forms are valid):

<code>%d</code>	decimal conversion
<code>%o</code>	octal conversion
<code>%h, %x</code>	hexadecimal conversion
<code>%b</code>	binary conversion
<code>%e</code>	real exponential conversion
<code>%f</code>	real decimal conversion
<code>%g</code>	real decimal or exponential conversion
<code>%s</code>	string (no conversion)

The first string from the list of *plusargs* provided to the simulator, which matches the *plusarg_string* portion of the *user_string* specified shall be the *plusarg* string available for conversion. The remainder string of the matching *plusarg* (the remainder is the part of the *plusarg* string after the portion that matches the user's *plusarg_string*) shall be converted from a string into the format indicated by the format string and stored in the variable provided. If there is no remaining string, the value stored into the variable shall be either a zero or an empty string value.

If the size of the variable is larger than the value after conversion, the value stored is zero-padded to the width of the variable. If the variable cannot contain the value after conversion, the value shall be truncated. If the value is negative, the value shall be considered larger than the variable provided. If characters exist in the string available for conversion that are illegal for the specified conversion, the variable shall be written with the value 'bx'.

Given the SystemVerilog code:

```
`define STRING logic [1024 * 8:1]

module goodtasks;
  `STRING str;
  integer i1;
  logic [31:0] vect;
  real realvar;

  initial
    begin
      if ($value$plusargs("TEST=%d", i1))
        $display("value was %d", i1);
      else
        $display("+TEST= not found");
      #100 $finish;
    end
```

```
endmodule

module ieee1364_example;
  real frequency;
  logic [8*32:1] testname;
  logic [64*8:1] pstring;
  logic clk;

  initial
  begin
    if ($value$plusargs("TESTNAME=%s",testname))
      begin
        $display(" TESTNAME= %s.",testname);
        $finish;
      end

    if (!($value$plusargs("FREQ+%0F",frequency)))
      frequency = 8.33333; // 166 MHz
      $display("frequency = %f",frequency);

    pstring = "TEST%d";
    if ($value$plusargs(pstring, testname))
      $display("Running test number %0d.",testname);
    end
  endmodule
```

and adding to the tool's command line the *plusarg*

```
+TEST=5
```

will result in the following output:

```
value was          5
frequency = 8.333330
Running text number x.
```

Adding to the tool's command line the *plusarg*

```
+TESTNAME=t1
```

will result in the following output:

```
+TEST= not found
TESTNAME=          t1.
```

Adding to the tool's command line the *plusarg*

```
+FREQ+9.234
```

will result in the following output:

```
+TEST= not found
frequency = 9.234000
```

Adding to the tool's command line the *plusarg*

```
+TEST23
```

will result in the following output:

```
+TEST= not found  
frequency = 8.333330  
Running test number 23.
```

21.7 Value change dump (VCD) files

A *VCD file* contains information about value changes on selected variables in the design stored by VCD system tasks. The following two types of VCD files exist:

- a) *4-state*: to represent variable changes in 0, 1, x, and z with no strength information.
- b) *Extended*: to represent variable changes in all states and strength information.

This clause describes how to generate both types of VCD files and their format.

21.7.1 Creating 4-state VCD file

The steps involved in creating the 4-state VCD file are listed below and illustrated in [Figure 21-1](#).

- a) Insert the VCD system tasks in the SystemVerilog source file to define the dump file name and to specify the variables to be dumped.
- b) Run the simulation.

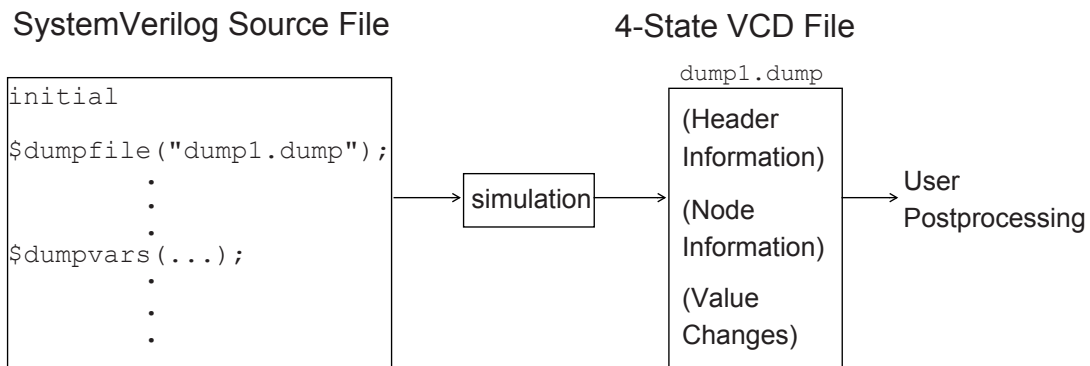

Figure 21-1—Creating the 4-state VCD file

A VCD file is an ASCII file that contains header information, variable definitions, and the value changes for all variables specified in the task calls.

Several system tasks can be inserted in the source description to create and control the VCD file.

21.7.1.1 Specifying name of dump file (\$dumpfile)

The `$dumpfile` task shall be used to specify the name of the VCD file. The syntax for the task is given in [Syntax 21-14](#).

```
dumpfile_task ::=
    $dumpfile ( filename ) ;
```

Syntax 21-14—Syntax for \$dumpfile task (not in [Annex A](#))

The *filename* is an expression that is a string literal, **string** data type, or an integral data type containing a character string that names the file to be opened. The *filename* is optional and defaults to the literal string `dump.vcd` if not specified.

For example:

```
initial $dumpfile ("module1.dump") ;
```

21.7.1.2 Specifying variables to be dumped (\$dumpvars)

The `$dumpvars` task shall be used to list which variables to dump into the file specified by `$dumpfile`. The `$dumpvars` task can be invoked as often as desired throughout the model (for example, within various blocks), but the execution of all the `$dumpvars` tasks shall be at the same simulation time.

The `$dumpvars` task can be used with or without arguments. The syntax for the `$dumpvars` task is given in [Syntax 21-15](#).

```
dumpvars_task ::=
    $dumpvars ;
    | $dumpvars ( levels [ , list_of_modules_or_variables ] ) ;
list_of_modules_or_variables ::=
    module_or_variable { , module_or_variable }
module_or_variable ::=
    module_identifier
    | variable_identifier
```

Syntax 21-15—Syntax for \$dumpvars task (not in [Annex A](#))

When invoked with no arguments, `$dumpvars` dumps all the variables in the model to the VCD file.

When the `$dumpvars` task is specified with arguments, the first argument indicates how many *levels* of the hierarchy below each specified module instance to dump to the VCD file. Subsequent arguments specify which scopes of the model to dump to the VCD file. These arguments can specify entire modules or individual variables within a module.

Setting the first argument to 0 causes a dump of all variables in the specified module and in all module instances below the specified module. The argument 0 applies only to subsequent arguments that specify module instances, and not to individual variables.

Example 1:

```
$dumpvars (1, top);
```

Because the first argument is a 1, this invocation dumps all variables within the module `top`; it does not dump variables in any of the modules instantiated by module `top`.

Example 2:

```
$dumpvars (0, top);
```

In this example, the `$dumpvars` task shall dump all variables in the module `top` and in all module instances below module `top` in the hierarchy.

Example 3: This example shows how the `$dumpvars` task can specify both modules and individual variables.

```
$dumpvars (0, top.mod1, top.mod2.net1);
```

This call shall dump all variables in module `mod1` and in all module instances below `mod1`, along with variable `net1` in module `mod2`. The argument `0` applies only to the module instance `top.mod1` and not to the individual variable `top.mod2.net1`.

21.7.1.3 Stopping and resuming the dump (`$dumpoff`/`$dumpon`)

Executing the `$dumpvars` task causes the value change dumping to start at the end of the current simulation time unit. To suspend the dump, the `$dumpoff` task can be invoked. To resume the dump, the `$dumpon` task can be invoked. The syntax of these two tasks is given in [Syntax 21-16](#).

```
dumpoff_task ::=  
    $dumpoff ;  
dumpon_task ::=  
    $dumpon ;
```

Syntax 21-16—Syntax for `$dumpoff` and `$dumpon` tasks (not in [Annex A](#))

When the `$dumpoff` task is executed, a checkpoint is made in which every selected variable is dumped as an `x` value. When the `$dumpon` task is later executed, each variable is dumped with its value at that time. In the interval between `$dumpoff` and `$dumpon`, no value changes are dumped.

The `$dumpoff` and `$dumpon` tasks provide the mechanism to control the simulation period during which the dump shall take place.

For example:

```
initial begin  
    #10    $dumpvars ( . . . );  
  
    #200   $dumpoff;  
  
    #800   $dumpon;  
  
    #900   $dumpoff;  
end
```

This example starts the VCD after 10 time units, stops it 200 time units later (at time 210), restarts it again 800 time units later (at time 1010), and stops it 900 time units later (at time 1910).

21.7.1.4 Generating a checkpoint (\$dumpall)

The \$dumpall task creates a checkpoint in the VCD file that shows the current value of all selected variables. The syntax is given in [Syntax 21-17](#).

```
dumpall_task ::=  
    $dumpall ;
```

Syntax 21-17—Syntax for \$dumpall task (not in [Annex A](#))

When dumping is enabled, the value change dumper records the values of the variables that change during each time increment. Values of variables that do not change during a time increment are not dumped.

21.7.1.5 Limiting size of dump file (\$dumplimit)

The \$dumplimit task can be used to set the size of the VCD file. The syntax for this task is given in [Syntax 21-18](#).

```
dumplimit_task ::=  
    $dumplimit ( filesize ) ;
```

Syntax 21-18—Syntax for \$dumplimit task (not in [Annex A](#))

The *filesize* argument specifies the maximum size of the VCD file in bytes. When the size of the VCD file reaches this number of bytes, the dumping stops, and a comment is inserted in the VCD file indicating the dump limit was reached.

21.7.1.6 Reading dump file during simulation (\$dumpflush)

The \$dumpflush task can be used to empty the VCD file buffer of the operating system to verify all the data in that buffer are stored in the VCD file. After executing a \$dumpflush task, dumping is resumed as before so no value changes are lost. The syntax for the task is given in [Syntax 21-19](#).

```
dumpflush_task ::=  
    $dumpflush ;
```

Syntax 21-19—Syntax for \$dumpflush task (not in [Annex A](#))

A common application is to call \$dumpflush to update the dump file so an application program can read the VCD file during a simulation.

Example 1—This example shows how the \$dumpflush task can be used in a SystemVerilog source file.

```
initial begin  
    $dumpvars ;  
    .  
    .  
    .  
    $dumpflush ;
```

```
$(applications program) ;
```

```
end
```

Example 2—The following is a simple source description example to produce a VCD file:

In this example, the name of the dump file is `verilog.dump`. It dumps value changes for all variables in the model. Dumping begins when an event `do_dump` occurs. The dumping continues for 500 clock cycles and then stops and waits for the event `do_dump` to be triggered again. At every 10000 time steps, the current values of all VCD variables are dumped.

```
module dump;
  event do_dump;

  initial $dumpfile("verilog.dump");
  initial @do_dump
    $dumpvars;      //dump variables in the design

  always @do_dump    //to begin the dump at event do_dump
  begin
    $dumpon;        //no effect the first time through
    repeat (500) @(posedge clock); //dump for 500 cycles
    $dumpoff;      //stop the dump
  end

  initial @(do_dump)
    forever #10000 $dumpall; // checkpoint all variables
endmodule
```

21.7.2 Format of 4-state VCD file

The dump file is structured in a free format. White space is used to separate commands and to make the file easily readable by a text editor.

21.7.2.1 Syntax of 4-state VCD file

The syntax of the 4-state VCD file is given in [Syntax 21-20](#).

```
value_change_dump_definitions ::=
  { declaration_command } { simulation_command }
declaration_command ::=
  $comment [ comment_text ] $end
  | $date [ date_text ] $end
  | $enddefinitions $end
  | $scope [ scope_type scope_identifier ] $end
  | $timescale [ time_number time_unit ] $end
  | $upscope $end
  | $var [ var_type size identifier_code reference ] $end
  | $version [ version_text system_task ] $end
simulation_command ::=
  $dumpall { value_change } $end
  | $dumpoff { value_change } $end
  | $dumpon { value_change } $end
```

```

| $dumpvars { value_change } $end
| $comment [ comment_text ] $end
| simulation_time
| value_change
scope_type ::=
    begin
    | fork
    | function
    | module
    | task
time_number ::= 1 | 10 | 100
time_unit ::= s | ms | us | ns | ps | fs
var_type ::=
    event | integer | parameter | real | realtime | reg | supply0 | supply1 | time
    | tri | triand | trior | trireg | tri0 | tril | wand | wire | wor
simulation_time ::= # decimal_number
value_change ::=
    scalar_value_change
    | vector_value_change
scalar_value_change ::= value identifier_code
value ::= 0 | 1 | x | X | z | Z
vector_value_change ::=
    b binary_number identifier_code
    | B binary_number identifier_code
    | r real_number identifier_code
    | R real_number identifier_code
identifier_code ::= { ASCII character }
size ::= decimal_number
reference ::=
    identifier
    | identifier [ bit_select_index ]
    | identifier [ msb_index : lsb_index ]
index ::= decimal_number
scope_identifier ::= { ASCII character }
comment_text ::= { ASCII character }
date_text ::= { ASCII character }
version_text ::= { ASCII character }
system_task ::= ${ASCII character}

```

Syntax 21-20—Syntax for output 4-state VCD file (not in [Annex A](#))

The VCD file starts with header information giving the date, the version number of the simulator used for the simulation, and the timescale used. Next, the file contains definitions of the scope and type of variables being dumped, followed by the actual value changes at each simulation time increment. Only the variables that change value during a time increment are listed.

The simulation time recorded in the VCD file is the absolute value of the simulation time for the changes in variable values that follow.

Value changes for real variables are specified by real numbers. Value changes for all other variables are specified in binary format by 0, 1, x, or z values. Strength information and memories are not dumped.

A real number is dumped using a `%.16g printf()` format. This preserves the precision of that number by outputting all 53 bits in the mantissa of a 64-bit IEEE 754 double-precision number. Application programs can read a real number using a `%g` format to `scanf()`.

The value change dumper generates character identifier codes to represent variables. The identifier code is a code composed of the printable characters, which are in the ASCII character set from ! to ~ (decimal 33 to 126).

The VCD format does not support a mechanism to dump part of a vector. For example, bits 8 to 15 (`[8:15]`) of a 16-bit vector cannot be dumped in VCD file; instead, the entire vector (`[0:15]`) has to be dumped. In addition, expressions, such as `a + b`, cannot be dumped in the VCD file.

Data in the VCD file are case sensitive.

21.7.2.2 Formats of variable values

Variables can be either scalars or vectors. Each type is dumped in its own format. Dumps of value changes to scalar variables shall not have any white space between the value and the identifier code.

Dumps of value changes to vectors shall not have any white space between the base letter and the value digits, but they shall have one white space between the value digits and the identifier code.

The output format for each value is right-justified. Vector values appear in the shortest form possible: redundant bit values that result from left-extending values to fill a particular vector size are eliminated.

The rules for left-extending vector values are given in [Table 21-9](#).

Table 21-9—Rules for left-extending vector values

When the value is	VCD left-extends with
1	0
0	0
Z	Z
X	X

[Table 21-10](#) shows how the VCD can shorten values.

Table 21-10—How the VCD can shorten values

Binary value	Extends to fill a 4-bit reg as	Appears in the VCD file as
10	0010	b10
X10	XX10	bX10
ZX0	ZZX0	bZX0
0X10	0X10	b0X10

Events are dumped in the same format as scalars; for example, 1*%. For events, however, the value (1 in this example) is irrelevant. Only the identifier code (*% in this example) is significant. It appears in the VCD file as a marker to indicate the event was triggered during the time step.

For example:

```
1*@      No space between the value 1 and the identifier code *@

b1100x01z (k      No space between the b and 1100x01z,
                  but a space between b1100x01z and (k
```

21.7.2.3 Description of keyword commands

The general information in the VCD file is presented as a series of sections surrounded by keywords. Keyword commands provide a means of inserting information in the VCD file. Keyword commands can be inserted either by the dumper or manually.

This subclause deals with the keyword commands given in [Table 21-11](#).

Table 21-11—Keyword commands

Declaration keywords		Simulation keywords
\$comment	\$timescale	\$dumpall
\$date	\$upscope	\$dumpoff
\$enddefinitions	\$var	\$dumpon
\$scope	\$version	\$dumpvars

The \$comment section provides a means of inserting a comment in the VCD file. For example:

```
$comment This is a single-line comment    $end
$comment This is a
multiple-line comment
$end
```

The \$date section indicates the date on which the VCD file was generated. For example:

```
$date
  June 25, 1989 09:24:35
$end
```

The \$enddefinitions section marks the end of the header information and definitions.

The \$scope section defines the scope of the variables being dumped. The scope type indicates one of the following scopes:

```
module  Top-level module and module instances
task    Tasks
function Functions
begin   Named sequential blocks
fork    Named parallel blocks
```

For example:

```
$scope
  module top
$end
```

The `$timescale` keyword specifies what timescale was used for the simulation. For example:

```
$timescale 10 ns $end
```

The `$upscope` section indicates a change of scope to the next higher level in the design hierarchy.

The `$var` section prints the names and identifier codes of the variables being dumped. The *size* specifies how many bits are in the variable. The *identifier code* specifies the name of the variable using printable ASCII characters, as previously described.

- a) The *msb index* indicates the most significant index; the *lsb index* indicates the least significant index.
- b) More than one reference name can be mapped to the same identifier code. For example, `net10` and `net15` can be interconnected in the circuit and, therefore, have the same identifier code.
- c) The individual bits of vector nets can be dumped individually.
- d) The identifier is the name of the variable being dumped in the model.

In the `$var` section, a net of net type **uwire** shall have a `var_type` of **wire**.

For example:

```
$var
  integer 32 (2 index)
$end
```

The `$version` section indicates which version of the VCD writer was used to produce the VCD file and the `$dumpfile` system task used to create the file. If a variable or an expression was used to specify the *file-name* within `$dumpfile`, the unevaluated variable or expression literal shall appear in the `$version` string. For example:

```
$version
  VERILOG-SIMULATOR 1.0a
  $dumpfile("dump1.dump")
$end
```

The `$dumpall` keyword specifies current values of all variables dumped. For example:

```
$dumpall 1*@ x*# 0*$ bx (k $end
```

The `$dumpoff` keyword indicates all variables dumped with X values. For example:

```
$dumpoff x*@ x*# x*$ bx (k $end
```

The `$dumpon` keyword indicates resumption of dumping and lists current values of all variables dumped. For example:

```
$dumpon x*@ 0*# x*$ b1 (k $end
```

The section beginning with `$dumpvars` keyword lists initial values of all variables dumped. For example:

```
$dumpvars x*@ z*$ b0 (k $end
```

21.7.2.4 4-state VCD file format example

The following example illustrates the format of the 4-state VCD file:

```
$date June 26, 1989 10:05:41
$end
$version VERILOG-SIMULATOR 1.0a
$end
$timescale 1 ns
$end
$scope module top $end
$scope module m1 $end
$var trireg 1 *@ net1 $end
$var trireg 1 *# net2 $end
$var trireg 1 *$ net3 $end
$upscope $end
$scope task t1 $end
$var reg 32 (k accumulator[31:0] $end
$var integer 32 {2 index $end
$upscope $end
$upscope $end
$enddefinitions $end
$comment
    $dumpvars was executed at time '#500'.
    All initial values are dumped at this time.
$end
#500
$dumpvars
x*@
x*#
x*$
bx (k
bx {2
$end
#505
0*@
1*#
1*$
b10zx1110x11100 (k
b1111000101z01x {2
#510
0*$
#520
1*$
#530
0*$
bz (k
#535
$dumpall 0*@ 1*# 0*$
bz (k
b1111000101z01x {2
$end
#540
1*$
#1000
$dumpoff
x*@
x*#
```

```
x*$
bx (k
bx {2
$end
#2000
$dumpon
z*@
1*#
0*$
b0 (k
bx {2
$end
#2010
1*$
```

21.7.3 Creating extended VCD file

The steps involved in creating the extended VCD file are listed below and illustrated in [Figure 21-2](#).

- a) Insert the extended VCD system tasks in the SystemVerilog source file to define the dump file name and to specify the variables to be dumped.
- b) Run the simulation.

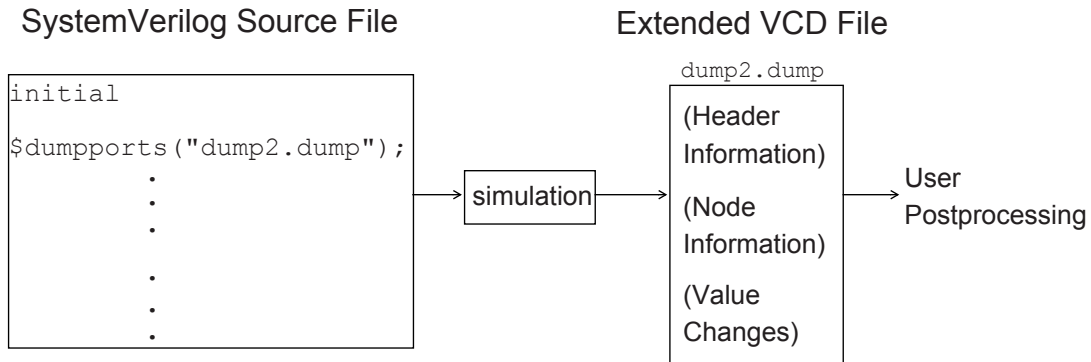

Figure 21-2—Creating the extended VCD file

The 4-state VCD file rules and syntax apply to the extended VCD file unless otherwise stated in this subclause.

21.7.3.1 Specifying dump file name and ports to be dumped (\$dumpports)

The `$dumpports` task shall be used to specify the name of the VCD file and the ports to be dumped. The syntax for the task is given in [Syntax 21-21](#).

```
dumpports_task ::=
    $dumpports ( scope_list , filename ) ;
scope_list ::=
    module_identifier { , module_identifier }
```

Syntax 21-21—Syntax for \$dumpports task (not in [Annex A](#))

The arguments are optional and are defined as follows:

The *scope_list* is one or more *module_identifiers*. Only modules are allowed (not variables). If more than one *module_identifier* is specified, they shall be separated by a comma. Path names to modules are allowed, using the period hierarchy separator. Literal strings are not allowed for the *module_identifier*. If no *scope_list* value is provided, the scope shall be the module from which `$dumpports` is called.

The *filename* is an expression that is a string literal, **string** data type, or an integral data type containing a character string that denotes the file which shall contain the port VCD information. If no *filename* is provided, the file shall be written to the current working directory with the name *dumpports.vcd*. If that file already exists, it shall be silently overwritten. All file-writing checks shall be made by the simulator (e.g., write rights, correct path name) and appropriate errors or warnings issued.

The following rules apply to the use of the `$dumpports` system task:

- All the ports in the model from the point of the `$dumpports` call are considered primary I/O pins and shall be included in the VCD file. However, any ports that exist in instantiations below *scope_list* are not dumped.
- If no arguments are specified for the task, `$dumpports`; and `$dumpports()`; are allowed. In both of these cases, the default values for the arguments shall be used.
- If the first argument is null, a comma shall be used before specifying the second argument in the argument list.
- Each scope specified in the *scope_list* shall be unique. If multiple calls to `$dumpports` are specified, the *scope_list* values in these calls shall also be unique.
- The `$dumpports` task can be used in source code that also contains the `$dumpvars` task.
- When `$dumpports` executes, the associated value change dumping shall start at the end of the current simulation time unit.
- The `$dumpports` task can be invoked multiple times throughout the model, but the execution of all `$dumpports` tasks shall be at the same simulation time. Specifying the same *filename* multiple times is not allowed.

21.7.3.2 Stopping and resuming the dump (`$dumpportsoff/$dumpportson`)

The `$dumpportsoff` and `$dumpportson` system tasks provide a means to control the simulation period for dumping port values. The syntax for these system tasks is given in [Syntax 21-22](#).

```
dumpportsoff_task ::=
    $dumpportsoff ( filename ) ;
dumpportson_task ::=
    $dumpportson ( filename ) ;
```

Syntax 21-22—Syntax for `$dumpportsoff` and `$dumpportson` system tasks (not in [Annex A](#))

The *filename* is an expression that is a string literal, **string** data type, or an integral data type containing a character string that denotes the *filename* specified in the `$dumpports` system task.

When the `$dumpportsoff` task is executed, a checkpoint is made in the *filename* where each specified port is dumped with an X value. Port values are no longer dumped from that simulation time forward. If *filename* is not specified, all dumping to files opened by `$dumpports` calls shall be suspended.

When the `$dumpportson` task is executed, all ports specified by the associated `$dumpports` call shall have their values dumped. This system task is typically used to resume dumping after the execution of `$dumpportsoff`. If *filename* is not specified, dumping shall resume for all files specified by `$dumpports` calls, if dumping to those files was stopped.

If `$dumpportson` is executed while ports are already being dumped to *filename*, the system task is ignored. If `$dumpportsoff` is executed while port dumping is already suspended for *filename*, the system task is ignored.

21.7.3.3 Generating a checkpoint (`$dumpportsall`)

The `$dumpportsall` system task creates a checkpoint in the VCD file that shows the value of all selected ports at that time in the simulation, regardless of whether the port values have changed since the last time step. The syntax for this system task is given in [Syntax 21-23](#).

```
dumpportsall_task ::=  
    $dumpportsall ( filename ) ;
```

Syntax 21-23—Syntax for \$dumpportsall system task (not in [Annex A](#))

The *filename* is an expression that is a string literal, **string** data type, or an integral data type containing a character string that denotes the *filename* specified in the `$dumpports` system task.

If the *filename* is not specified, checkpointing occurs for all files opened by calls to `$dumpports`.

21.7.3.4 Limiting size of dump file (`$dumpportslimit`)

The `$dumpportslimit` system task allows control of the VCD file size. The syntax for this system task is given in [Syntax 21-24](#).

```
dumpportslimit_task ::=  
    $dumpportslimit ( filesize , filename ) ;
```

Syntax 21-24—Syntax for \$dumpportslimit system task (not in [Annex A](#))

The *filesize* integer argument is required, and it specifies the maximum size in bytes for the associated *filename*. When this *filesize* is reached, the dumping stops, and a comment is inserted into *filename* indicating the size limit was attained.

The *filename* is an expression that is a string literal, **string** data type, or an integral data type containing a character string that denotes the *filename* specified in the `$dumpports` system task.

If the *filename* is not specified, the *filesize* limit applies to all files opened for dumping due to calls to `$dumpports`.

21.7.3.5 Reading dump file during simulation (`$dumpportsflush`)

To facilitate performance, simulators often buffer VCD output and write to the file at intervals, instead of line by line. The `$dumpportsflush` system task writes all port values to the associated file, clearing a simulator's VCD buffer.

The syntax for this system task is given in [Syntax 21-25](#).

```
dumpportsflush_task ::=
    $dumpportsflush ( filename ) ;
```

Syntax 21-25—Syntax for \$dumpportsflush system task (not in [Annex A](#))

The *filename* is an expression that is a string literal, **string** data type, or an integral data type containing a character string that denotes the *filename* specified in the \$dumpports system task.

If the *filename* is not specified, the VCD buffers shall be flushed for all files opened by calls to \$dumpports.

21.7.3.6 Description of keyword commands

The general information in the extended VCD file is presented as a series of sections surrounded by keywords. Keyword commands provide a means of inserting information in the extended VCD file. Keyword commands can be inserted either by the dumper or manually. Extended VCD provides one additional keyword command to that of the 4-state VCD.

21.7.3.6.1 \$vdcfclose

The **\$vdcfclose** keyword indicates the final simulation time at the time the extended VCD file is closed. This allows accurate recording of the end simulation time, regardless of the state of signal changes, in order to assist parsers that require this information. The syntax for the keyword is given in [Syntax 21-26](#).

```
vdcfclose_task ::=
    $vdcfclose final_simulation_time $end
```

Syntax 21-26—Syntax for \$vdcfclose keyword (not in [Annex A](#))

For example:

```
$vdcfclose #13000 $end
```

21.7.3.7 General rules for extended VCD system tasks

For each extended VCD system task, the following rules apply:

- If a *filename* is specified that does not match a *filename* specified in a \$dumpports call, the control task shall be ignored.
- If no arguments are specified for the tasks that have only optional arguments, the system task name can be used with no arguments or the name followed by () can be specified, for example, \$dumpportsflush or \$dumpportsflush (). In both of these cases, the default actions for the arguments shall be executed.

21.7.4 Format of extended VCD file

The format of the extended VCD file is similar to that of the 4-state VCD file, as it is also structured in a free format. White space is used to separate commands and to make the file easily readable by a text editor.

21.7.4.1 Syntax of extended VCD file

The syntax of the extended VCD file is given in [Syntax 21-27](#). A 4-state VCD construct name that matches an extended VCD construct shall be considered equivalent, except if preceded by an *.

```

value_change_dump_definitions ::= {declaration_command} {simulation_command}
declaration_command ::= declaration_keyword [command_text] $end
simulation_command ::=
    simulation_keyword { value_change } $end
    | $comment [comment_text] $end
    | simulation_time
    | value_change
declaration_keyword ::=
    $comment | $date | $enddefinitions | $scope | $timescale | $upscope | $var | $vcdclose |
    $version
command_text ::=
    comment_text | close_text | date_section | scope_section | timescale_section | var_section
    | version_section
simulation_keyword ::= $dumpports | $dumpportsoff | $dumpportson | $dumpportsall
simulation_time ::= #decimal_number
final_simulation_time ::= simulation_time
value_change ::= value identifier_code
value ::= pport_value 0_strength_component 1_strength_component
port_value ::= input_value | output_value | unknown_direction_value
input_value ::= D | U | N | Z | d | u
output_value ::= L | H | X | T | 1 | h
unknown_direction_value ::= 0 | 1 | ? | F | A | a | B | b | C | c | f
strength_component ::= 0 | 1 | 2 | 3 | 4 | 5 | 6 | 7
identifier_code ::= <{integer}
comment_text ::= {ASCII_character}
close_text ::= final_simulation_time
date_section ::= date_text
date_text ::= day month date time year
scope_section ::= scope_type scope_identifier
scope_type ::= module
timescale_section ::= number time_unit
number ::= 1 | 10 | 100
time_unit ::= fs | ps | ns | us | ms | s
var_section ::= var_type size identifier_code reference
var_type ::= port
size ::= 1 | vector_index
vector_index ::= [ msb_index : lsb_index ]
index ::= decimal_number
msb_index ::= index
lsb_index ::= index

```

```

reference ::= port_identifier
identifier ::= {printable_ASCII_character}
version_section ::= version_text
version_text ::= version_identifier {dumpports_command}
dumpports_command ::=
    $dumpports (scope_identifier , string_literal | variable | expression )

```

Syntax 21-27—Syntax for output extended VCD file (not in [Annex A](#))

The extended VCD file starts with header information giving the date, the version number of the simulator used for the simulation, and the timescale used. Next, the file contains definitions of the scope of the ports being dumped, followed by the actual value changes at each simulation time increment. Only the ports that change value during a time increment are listed.

The simulation time recorded in the extended VCD file is the absolute value of the simulation time for the changes in port values that follow.

Value changes for all ports are specified in binary format by 0, 1, x, or z values and include strength information.

A real number is dumped using a `%.16g printf()` format. This preserves the precision of that number by outputting all 53 bits in the mantissa of a 64-bit IEEE 754 double-precision number. Application programs can read a real number using a `%g` format to `scanf()`.

The extended VCD format does not support a mechanism to dump part of a vector. For example, bits 8 to 15 (`[8:15]`) of a 16-bit vector cannot be dumped in VCD file; instead, the entire vector (`[0:15]`) has to be dumped. In addition, expressions, such as `a + b`, cannot be dumped in the VCD file.

Data in the extended VCD file are case sensitive.

21.7.4.2 Extended VCD node information

The node information section (also referred to as the *variable definitions section*) is affected by the `$dumpports` task as [Syntax 21-28](#) shows.

```

$var var_type size < identifier_code reference $end
var_type ::= port
size ::= 1 | vector_index
vector_index ::= [ msb_index : lsb_index ]
index ::= decimal_number
identifier_code ::= integer
reference ::= port_identifier

```

Syntax 21-28—Syntax for extended VCD node information (not in [Annex A](#))

The constructs are defined as follows:

`var_type` The keyword `port`. No other keyword is allowed.

size	A decimal number indicating the number of bits in the port. If the port is a single bit, the value shall be 1. If the port is a bus, the actual index is printed. The <i>msb</i> indicates the most significant index; <i>lsb</i> , the least significant index.
identifier_code	An integer preceded by <, which starts at zero and ascends in one-unit increments for each port, in the order found in the module declaration.
reference	Identifier indicating the port name.

For example:

```

module test_device(count_out, carry, data, reset)
  output count_out, carry ;
  input [0:3] data;
  input reset;
  . . .
  initial
    begin
      $dumpports(testbench.DUT, "testoutput.vcd");
    . . .
  end
endmodule

```

This example produces the following node information in the VCD file:

```

$scope module testbench.DUT $end
$var port 1 <0 count_out $end
$var port 1 <1 carry $end
$var port [0:3] <2 data $end
$var port 1 <3 reset $end
$upscope $end

```

At least one space shall separate each syntactical element. However, the formatting of the information is the choice of the simulator vendor. All 4-state VCD syntax rules for the *vector_index* apply.

If the *vector_index* appears in the port declaration, this shall be the index dumped. If the *vector_index* is not in the port declaration, the *vector_index* in the net or variable declaration matching the port name shall be dumped. If no *vector_index* is found, the port is considered scalar (1 bit wide).

Concatenated ports shall appear in the extended VCD file as separate entries.

For example:

```

module addbit ({A, b}, ci, sum, co);
  input A, b, ci;
  output sum, co;
  . . .

```

The VCD file output looks like the following:

```

$scope module addbit $end
$var port 1 <0 A $end
$var port 1 <1 b $end
$var port 1 <2 ci $end
$enddefinitions $end
. . .

```

21.7.4.3 Value changes

The value change section of the VCD file is also affected by `$dumpports`, as [Syntax 21-29](#) shows.

```
value ::= pport_value 0_strength_component 1_strength_component
```

Syntax 21-29—Syntax for value change section (not in [Annex A](#))

The constructs are defined as follows:

p	Key character that indicates a port. There is no space between the p and the <i>port_value</i> .
<i>port_value</i>	State character (described below).
<i>0_strength_component</i>	One of the eight SystemVerilog strengths that indicates the <i>strength0</i> specification for the port.
<i>1_strength_component</i>	One of the eight SystemVerilog strengths that indicates the <i>strength1</i> specification for the port.

The SystemVerilog strength values are as follows (append keyword with 0 or 1 as appropriate for the strength component):

0	highz
1	small
2	medium
3	weak
4	large
5	pull
6	strong
7	supply
identifier_code	the integer preceded by the < character as defined in the <code>\$var</code> construct for the port.

21.7.4.3.1 State characters

The following state information is listed in terms of input values from a test fixture, the output values of the device under test (DUT), and the states representing unknown direction:

INPUT (TESTFIXTURE):

D	low
U	high
N	unknown
Z	three-state
d	low (two or more drivers active)
u	high (two or more drivers active)

OUTPUT (DUT):

L	low
H	high
X	unknown (do-not care)

T	three-state
l	low (two or more drivers active)
h	high (two or more drivers active)

UNKNOWN DIRECTION:

0	low (both input and output are active with 0 value)
1	high (both input and output are active with 1 value)
?	unknown
F	three-state (input and output unconnected)
A	unknown (input 0 and output 1)
a	unknown (input 0 and output X)
B	unknown (input 1 and output 0)
b	unknown (input 1 and output X)
C	unknown (input X and output 0)
c	unknown (input X and output 1)
f	unknown (input and output three-stated)

21.7.4.3.2 Drivers

Drivers are considered only in terms of primitives, continuous assignments, and procedural continuous assignments. Value 0/1 means both input and output are active with value 0/1. 0 and 1 are conflict states.

The following rules apply to conflicts:

- If both input and output are driving the same value with the same range of strength, then this is a conflict. The resolved value is 0/1, and the strength is the stronger of the two.
- If the input is driving a strong strength (range) and the output is driving a weak strength (range), the resolved value is d/u, and the strength is the strength of the input.
- If the input is driving a weak strength (range) and the output is driving a strong strength (range), then the resolved value is l/h, and the strength is the strength of the output.

Range is as follows:

- Strength 7 to 5 : strong strength
- Strength 4 to 1: weak strength

21.7.4.4 Extended VCD file format example

The following example illustrates the format of the extended VCD file.

A module declaration:

```

module adder(data0, data1, data2, data3, carry, as, rdn, reset,
             test, write);
  inout data0, data1, data2, data3;
  output carry;
  input as, rdn, reset, test, write;
  . . .

```

and the resulting VCD fragment:

```

$scope module testbench.adder_instance $end
$var port 1 <0 data0 $end

```

```

$var port      1 <1      data1 $end
$var port      1 <2      data2 $end
$var port      1 <3      data3 $end
$var port      1 <4      carry $end
$var port      1 <5      as    $end
$var port      1 <6      rdn   $end
$var port      1 <7      reset $end
$var port      1 <8      test  $end
$var port      1 <9      write $end
$upscope $end
$enddefinitions $end
    
```

```

#0
$dumpports
pX 6 6 <0
pX 6 6 <1
pX 6 6 <2
pX 6 6 <3
pX 6 6 <4
pN 6 6 <5
pN 6 6 <6
pU 0 6 <7
pD 6 0 <8
pN 6 6 <9
$end
#180
pH 0 6 <4
#200000
pD 6 0 <5
pU 0 6 <6
pD 6 0 <9
#200500
pf 0 0 <0
pf 0 0 <1
pf 0 0 <2
pf 0 0 <3
    
```

21.7.5 VCD SystemVerilog type mappings

SystemVerilog does not extend the IEEE 1364-2005 VCD format. Some SystemVerilog types can be dumped into a standard VCD file by masquerading as an IEEE 1364-2005 type. [Table 21-12](#) lists the basic SystemVerilog types and their mapping to an IEEE 1364-2005 type for VCD dumping.

Table 21-12—VCD type mapping

SystemVerilog	Verilog 1364-2005	Size
bit	reg	Total size of packed dimension
logic	reg	Total size of packed dimension
int	integer	32
shortint	reg	16
longint	reg	64

Table 21-12—VCD type mapping (continued)

SystemVerilog	Verilog 1364-2005	Size
byte	reg	8
enum	integer	32
shortreal	real	—

Packed arrays and structures are dumped as a single vector of **reg**. Multiple packed array dimensions are collapsed into a single dimension.

If an **enum** declaration specified a type, it is dumped as that type rather than the default shown above.

Unpacked structures appear as named fork-join blocks, and their member elements of the structure appear as the types above. Because named fork-join blocks with variable declarations are seldom used in testbenches and hardware models, this makes structures easy to distinguish from variables declared in begin-end blocks, which are more frequently used in testbenches and models.

Unpacked arrays and automatic variables are not dumped.

NOTE—The current VCD format does not indicate whether a variable has been declared as **signed** or **unsigned**.

22. Compiler directives

22.1 General

This clause describes the following compiler directives (listed alphabetically):

<code>`__FILE__</code>	[22.13]
<code>`__LINE__</code>	[22.13]
<code>`begin_keywords</code>	[22.14]
<code>`celldefine</code>	[22.10]
<code>`default_nettype</code>	[22.8]
<code>`define</code>	[22.5.1]
<code>`else</code>	[22.6]
<code>`elsif</code>	[22.6]
<code>`end_keywords</code>	[22.14]
<code>`endcelldefine</code>	[22.10]
<code>`endif</code>	[22.6]
<code>`ifdef</code>	[22.6]
<code>`ifndef</code>	[22.6]
<code>`include</code>	[22.4]
<code>`line</code>	[22.12]
<code>`nounconnected_drive</code>	[22.9]
<code>`pragma</code>	[22.11]
<code>`resetall</code>	[22.3]
<code>`timescale</code>	[22.7]
<code>`unconnected_drive</code>	[22.9]
<code>`undef</code>	[22.5.2]
<code>`undefineall</code>	[22.5.3]

22.2 Overview

All compiler directives are preceded by the (```) character. This character is called *grave accent* (ASCII 0x60). It is different from the character (`'`), which is the *apostrophe* character (ASCII 0x27). The scope of a compiler directive extends from the point where it is processed, across all files processed in the current compilation unit, to the point where another compiler directive supersedes it or the processing of the compilation unit completes. The semantics of compiler directives is defined in [3.12.1](#) and [5.6.4](#).

22.3 ``resetall`

When ``resetall` compiler directive is encountered during compilation, all compiler directives are set to the default values. This is useful for ensuring that only directives that are desired in compiling a particular source file are active.

The recommended usage is to place ``resetall` at the beginning of each source text file, followed immediately by the directives desired in the file.

It shall be illegal for the ``resetall` directive to be specified within a design element.

Not all compiler directives have a default value (e.g. ``define` and ``include`). Directives that do not have a default are not affected by ``resetall`.

22.4 ``include`

The file inclusion (``include`) compiler directive is used to insert the entire contents of a source file in another file during compilation. The result is as though the contents of the included source file appear in place of the ``include` compiler directive.

The syntax of the ``include` compiler directive is given in [Syntax 22-1](#).

```
include_compiler_directive ::=  
    `include " filename "  
    | `include < filename >
```

Syntax 22-1—Syntax for include compiler directive (not in [Annex A](#))

The compiler directive ``include` can be specified anywhere within the SystemVerilog source description.

Only white space or a comment may appear on the same line as the ``include` compiler directive.

The *filename* is the name of the file to be included in the source file. The *filename* can be a full or relative path name.

The *filename* can be enclosed in either quotes or angle brackets, which affects how a tool searches for the file.

- When the *filename* is enclosed in double quotes ("*filename*"), for a relative path the compiler's current working directory, and optionally user specified locations are searched.
- When the *filename* is enclosed in angle brackets (<*filename*>), then only an implementation-dependent location containing files defined by the language standard is searched. Relative path names are interpreted relative to that location.

When the *filename* is an absolute path, only that *filename* is included and only the double quote form of the ``include` can be used.

A file included in the source using the ``include` compiler directive may contain other ``include` compiler directives. The number of nesting levels for include files shall be finite. Implementations may limit the maximum number of levels to which include files can be nested, but the limit shall be at least 15.

Examples of ``include` compiler directives are as follows:

```
`include "parts/count.v"  
`include "fileB" // including fileB  
`include <List.vh>
```

22.5 ``define`, ``undef` and ``undefineall`

A text macro substitution facility has been provided so that meaningful names can be used to represent commonly used pieces of text. For example, in the situation where a constant number is repetitively used throughout a description, a text macro would be useful in that only one place in the source description would need to be altered if the value of the constant needed to be changed.

The text macro facility is not affected by the compiler directive ``resetall`.

22.5.1 `define`

The directive `define` creates a macro for text substitution. This directive can be used both inside and outside design elements. After a text macro is defined, it can be used in the source description by using the `(`)` character, followed by the macro name. The compiler shall substitute the text of the macro for the string `text_macro_name` and any actual arguments that follow it. All compiler directives shall be considered predefined macro names; it shall be illegal to redefine a compiler directive as a macro name.

A text macro can be defined with arguments. This allows the macro to be customized for each use individually.

The syntax for text macro definitions is given in [Syntax 22-2](#).

```

text_macro_definition ::=
    define text_macro_name macro_text
text_macro_name ::=
    text_macro_identifier [ ( list_of_formal_arguments ) ]
list_of_formal_arguments ::=
    formal_argument { , formal_argument }
formal_argument ::=
    simple_identifier [ = default_text ]
text_macro_identifier ::=
    identifier

```

Syntax 22-2—Syntax for text macro definition (not in [Annex A](#))

The macro text can be any arbitrary text specified on the same line as the text macro name. If more than one line is necessary to specify the text, the newline shall be preceded by a backslash (`\`). The first newline not preceded by a backslash shall end the macro text. The newline preceded by a backslash shall be replaced in the expanded macro with a newline (but without the preceding backslash character).

When formal arguments are used to define a text macro, the scope of the formal argument shall extend up to the end of the macro text. A formal argument can be used in the macro text in the same manner as an identifier.

If formal arguments are used, the list of formal argument names shall be enclosed in parentheses following the name of the macro. The formal argument names shall be *simple identifiers*, separated by commas and optionally white space. The left parenthesis shall follow the text macro name immediately, with no space in between.

A formal macro argument may have a default. A default is specified by appending an `=` token after the formal argument name, followed by the default text. The default text is substituted for the formal argument if no corresponding actual argument is specified.

The default text may be explicitly specified to be empty by adding an `=` token after the formal argument name, followed by a comma (or a right parenthesis if it is the last argument in the argument list).

If a one-line comment (that is, a comment specified with the characters `//`) is included in the text, then the comment shall not become part of the substituted text. The macro text can be blank, in which case the text macro is defined to be empty and no text is substituted when the macro is used.

The syntax for using a text macro is given in [Syntax 22-3](#)

```

text_macro_usage ::=
  `text_macro_identifier [ ( list_of_actual_arguments ) ]
list_of_actual_arguments ::=
  actual_argument { , actual_argument }
actual_argument ::=
  expression
  
```

Syntax 22-3—Syntax for text macro usage (not in [Annex A](#))

For a macro without arguments, the text shall be substituted as is for every occurrence of ``text_macro_identifier`. However, a text macro with one or more arguments shall be expanded by substituting each formal argument with the expression used as the actual argument in the macro usage.

To use a macro defined with arguments, the name of the text macro shall be followed by a list of actual arguments in parentheses, separated by commas. Actual arguments and defaults shall not contain comma or right parenthesis characters outside matched pairs of left and right parentheses (), square brackets [], braces { }, double quotes "", or an escaped identifier.

White space shall be allowed between the text macro name and the left parenthesis in the macro usage.

An actual argument may be empty or white space only, in which case the formal argument is substituted by the argument default if one is specified or by nothing if no default is specified.

If fewer actual arguments are specified than the number of formal arguments and all the remaining formal arguments have defaults, then the defaults are substituted for the additional formal arguments. It shall be an error if any of the remaining formal arguments does not have a default specified. For a macro with arguments, the parentheses are always required in the macro call, even if all the arguments have defaults. It shall be an error to specify more actual arguments than the number of formal arguments.

Example macro without defaults:

```

`define D(x,y) initial $display("start", x , y, "end");

`D( "msg1" , "msg2" )
  // expands to 'initial $display("start", "msg1" , "msg2", "end");'
`D( " msg1", )
  // expands to 'initial $display("start", " msg1" , , "end");'
`D(, "msg2 ")
  // expands to 'initial $display("start", , "msg2 ", "end");'
`D(,)
  // expands to 'initial $display("start", , , "end");'
`D( , )
  // expands to 'initial $display("start", , , "end");'
`D("msg1")
  // illegal, only one argument
`D()
  // illegal, only one empty argument
`D(,,)
  // illegal, more actual than formal arguments
  
```

Example macros with defaults:

```

`define MACRO1(a=5,b="B",c) $display(a,,b,,c);

`MACRO1 ( , 2, 3 ) // argument a omitted, replaced by default
// expands to '$display(5,,2,,3);'
`MACRO1 ( 1 , , 3 ) // argument b omitted, replaced by default
// expands to '$display(1,, "B",,3);'
`MACRO1 ( , 2, ) // argument c omitted, replaced by nothing
// expands to '$display(5,,2,,);'
`MACRO1 ( 1 ) // ILLEGAL: b and c omitted, no default for c

`define MACRO2(a=5, b, c="C") $display(a,,b,,c);

`MACRO2 (1, , 3) // argument b omitted, replaced by nothing
// expands to '$display(1,,,,3);'
`MACRO2 ( , 2, ) // a and c omitted, replaced by defaults
// expands to '$display(5,,2,, "C");'
`MACRO2 ( , 2) // a and c omitted, replaced by defaults
// expands to '$display(5,,2,, "C");'

`define MACRO3(a=5, b=0, c="C") $display(a,,b,,c);
`MACRO3 ( 1 ) // b and c omitted, replaced by defaults
// expands to '$display(1,,0,, "C");'
`MACRO3 ( ) // all arguments replaced by defaults
// expands to '$display(5,,0,, "C");'
`MACRO3 // ILLEGAL: parentheses required

```

Once a text macro name has been defined, it can be used anywhere in the compilation unit where it is defined. There are no other scope restrictions once inside the compilation unit. Implementations may also allow text macros to be defined and used interactively.

The text specified for macro text shall not be split across the following lexical tokens:

- Comments
- Numbers
- String literals
- Identifiers
- Keywords
- Operators

For example:

```

`define wordsize 8
logic [1:`wordsize] data;

//define a nand with variable delay
`define var_nand(dly) nand #dly

`var_nand(2) g121 (q21, n10, n11);
`var_nand(5) g122 (q22, n10, n11);

```

The following is illegal syntax because it is split across a string:

```

`define first_half "start of string
$display(`first_half end of string");

```

Each actual argument is substituted for the corresponding formal argument literally. Therefore, when an expression is used as an actual argument, the expression will be substituted in its entirety. This may cause an expression to be evaluated more than once if the formal argument was used more than once in the macro text. For example:

```
`define max(a,b) ((a) > (b) ? (a) : (b))
n = `max(p+q, r+s) ;
```

will expand as

```
n = ((p+q) > (r+s)) ? (p+q) : (r+s) ;
```

Here, the larger of the two expressions $p + q$ and $r + s$ will be evaluated twice.

The word `define` is known as a compiler directive keyword, and it is not part of the normal set of keywords. Thus, normal identifiers in a SystemVerilog source description can be the same as compiler directive keywords. The following problems should be considered:

- a) Text macro names shall not be the same as compiler directive keywords.
- b) Text macro names can reuse names being used as ordinary identifiers. For example, `signal_name` and ``signal_name` are different.
- c) Redefinition of text macros is allowed; the latest definition of a particular text macro read by the compiler prevails when the macro name is encountered in the source text.

The macro text and argument defaults may contain usages of other text macros. Such usages shall be substituted after the outer macro is substituted, not when it is defined. If an actual argument or an argument default contains a macro usage, the macro usage shall be expanded only after substitution into the outer macro text.

If a formal argument has a non-empty default and one wants to replace the formal argument with an empty actual argument, one cannot simply omit the actual argument, as then the default will be used. However, one can define an empty text macro, say ``EMPTY`, and use that as the actual argument. This will be substituted in place of the formal argument, and will be replaced by empty text after expansion of the empty text macro.

When a macro usage is passed as an actual argument or a default to another macro, the argument expansion does not introduce new uses of the formal arguments to the top-level macro.

Example:

```
`define TOP(a,b) a + b
`TOP( `TOP(b,1), `TOP(42,a) )
```

expands to: $b + 1 + 42 + a$
 not into: $42 + a + 1 + 42 + a$
 nor into: $b + 1 + 42 + b + 1$

It shall be an error for a macro to expand directly or indirectly to text containing another usage of itself (a recursive macro). However, an actual argument to a macro or a default may contain a usage of itself, as in the previous example.

Macro substitution and argument substitution shall not occur within string literals. For example,

```
module main;
  `define HI Hello
  `define LO "`HI, world"
  `define H(x) "Hello, x"
```

```

initial begin
  $display("`HI, world");
  $display(`LO);
  $display(`H(world));
end
endmodule

```

will print:

```

`HI, world
`HI, world
Hello, x

```

The ``define` macro text can also include ```, ````, and ````.

An ``` overrides the usual lexical meaning of `"` and indicates that the expansion shall include the quotation mark, substitution of actual arguments, and expansions of embedded macros. This allows string literals to be constructed from macro arguments.

A mixture of ``` and `"` is allowed in the macro text, however the use of `"` always starts a string literal and must have a terminating `"`. Any characters embedded inside this string literal, including ```, become part of the string in the replaced macro text. Thus, if `"` is followed by ```, the `"` starts a string literal whose last character is ``` and is terminated by the `"` of ```.

A ```` indicates that the expansion should include the escape sequence `\`. For example:

```

`define msg(x,y) `x: ``"y`"``"

```

An example of using this ``msg` macro is:

```

$display(`msg(left side,right side));

```

The example above expands to:

```

$display("left side: \"right side\)");

```

A ```` delimits lexical tokens without introducing white space, allowing identifiers to be constructed from arguments. For example:

```

`define append(f) f``_master

```

An example of using this ``append` macro is:

```

`append(clock)

```

This example expands to:

```

clock_master

```

The ``include` directive can be followed by a macro, instead of a string literal:

```

`define home(filename) `"/home/mydir/filename`"
`include `home(myfile)

```

22.5.2 ``undef`

The directive ``undef` shall undefine the specified text macro if previously defined by a ``define` compiler directive within the compilation unit. An attempt to undefine a text macro that was not previously defined using a ``define` compiler directive can issue a warning. The syntax for the ``undef` compiler directive is given in [Syntax 22-4](#).

```
undefine_compiler_directive ::=  
    `undef text_macro_identifier
```

Syntax 22-4—Syntax for undef compiler directive (not in [Annex A](#))

An undefined text macro has no value, just as if it had never been defined.

22.5.3 ``undefineall`

The ``undefineall` directive shall undefine all text macros previously defined by ``define` compiler directives within the compilation unit. This directive takes no arguments and may appear anywhere in the source description.

22.6 ``ifdef`, ``else`, ``elsif`, ``endif`, ``ifndef`

These conditional compilation compiler directives are used to include optionally lines of SystemVerilog source description during compilation.

These directives may appear anywhere in the source description.

Situations where the ``ifdef`, ``else`, ``elsif`, ``endif`, and ``ifndef` compiler directives may be useful include the following:

- Selecting different representations of a design element such as behavioral, structural, or switch level
- Choosing different timing or structural information
- Selecting different stimulus for a given run

The ``ifdef`, ``else`, ``elsif`, ``endif`, and ``ifndef` compiler directives have the syntax shown in [Syntax 22-5](#).

```
conditional_compilation_directive ::=  
    ifdef_directive  
    | ifndef_directive  
ifdef_directive ::=  
    `ifdef text_macro_identifier ifdef_group_of_lines  
    { `elsif text_macro_identifier elsif_group_of_lines }  
    [ `else else_group_of_lines ]  
    `endif  
ifndef_directive ::=  
    `ifndef text_macro_identifier ifndef_group_of_lines  
    { `elsif text_macro_identifier elsif_group_of_lines }  
    [ `else else_group_of_lines ]  
    `endif
```

Syntax 22-5—Syntax for conditional compilation directives (not in [Annex A](#))

The *text_macro_identifier* is a SystemVerilog *identifier*. The *ifdef_group_of_lines*, *ifndef_group_of_lines*, *elsif_group_of_lines*, and the *else_group_of_lines* are parts of a SystemVerilog source description. The ``else` and ``elsif` compiler directives and all of the groups of lines are optional.

The ``ifdef`, ``else`, ``elsif`, and ``endif` compiler directives work together in the following manner:

- When an ``ifdef` is encountered, the ``ifdef text_macro_identifier` is tested to see whether it is defined as a text macro name using ``define` within the SystemVerilog source description.
- If the ``ifdef text_macro_identifier` is defined, the ``ifdef` group of lines is compiled as part of the description; and if there are ``else` or ``elsif` compiler directives, these compiler directives and corresponding groups of lines are ignored.
- If the ``ifdef text_macro_identifier` has not been defined, the ``ifdef` group of lines is ignored.
- If there is an ``elsif` compiler directive, the ``elsif text_macro_identifier` is tested to see whether it is defined as a text macro name using ``define` within the SystemVerilog source description.
- If the ``elsif text_macro_identifier` is defined, the ``elsif` group of lines is compiled as part of the description; and if there are other ``elsif` or ``else` compiler directives, the other ``elsif` or ``else` directives and corresponding groups of lines are ignored.
- If the first ``elsif text_macro_identifier` has not been defined, the first ``elsif` group of lines is ignored.
- If there are multiple ``elsif` compiler directives, they are evaluated like the first ``elsif` compiler directive in the order they are written in the SystemVerilog source description.
- If there is an ``else` compiler directive, the ``else` group of lines is compiled as part of the description.

The ``ifndef`, ``else`, ``elsif`, and ``endif` compiler directives work together in the following manner:

- When an ``ifndef` is encountered, the ``ifndef text_macro_identifier` is tested to see whether it is defined as a text macro name using ``define` within the SystemVerilog source description.
- If the ``ifndef text_macro_identifier` is not defined, the ``ifndef` group of lines is compiled as part of the description; and if there are ``else` or ``elsif` compiler directives, these compiler directives and corresponding groups of lines are ignored.
- If the ``ifndef text_macro_identifier` is defined, the ``ifndef` group of lines is ignored.
- If there is an ``elsif` compiler directive, the ``elsif text_macro_identifier` is tested to see whether it is defined as a text macro name using ``define` within the SystemVerilog source description.
- If the ``elsif text_macro_identifier` is defined, the ``elsif` group of lines is compiled as part of the description; and if there are other ``elsif` or ``else` compiler directives, the other ``elsif` or ``else` directives and corresponding groups of lines are ignored.
- If the first ``elsif text_macro_identifier` has not been defined, the first ``elsif` group of lines is ignored.
- If there are multiple ``elsif` compiler directives, they are evaluated like the first ``elsif` compiler directive in the order they are written in the SystemVerilog source description.
- If there is an ``else` compiler directive, the ``else` group of lines is compiled as part of the description.

Although the names of compiler directives are contained in the same name space as text macro names, the names of compiler directives are considered not to be defined by ``ifdef`, ``ifndef`, and ``elseif`.

Nesting of ``ifdef`, ``ifndef`, ``else`, ``elsif`, and ``endif` compiler directives shall be permitted.

Any group of lines that the compiler ignores shall still follow the SystemVerilog lexical conventions for white space, comments, numbers, strings, identifiers, keywords, and operators.

Example 1—The example below shows a simple usage of an ``ifdef` directive for conditional compilation. If the identifier `behavioral` is defined, a continuous net assignment will be compiled in; otherwise, an `and` gate will be instantiated.

```

module and_op (a, b, c);
  output a;
  input b, c;

  `ifdef behavioral
    wire a = b & c;
  `else
    and a1 (a,b,c);
  `endif
endmodule

```

Example 2—The following example shows usage of nested conditional compilation directives:

```

module test(out);
  output out;
  `define wow
  `define nest_one
  `define second_nest
  `define nest_two
  `ifdef wow
    initial $display("wow is defined");
    `ifdef nest_one
      initial $display("nest_one is defined");
      `ifdef nest_two
        initial $display("nest_two is defined");
      `else
        initial $display("nest_two is not defined");
      `endif
    `else
      initial $display("nest_one is not defined");
    `endif
  `else
    initial $display("wow is not defined");
    `ifdef second_nest
      initial $display("second_nest is defined");
    `else
      initial $display("second_nest is not defined");
    `endif
  `endif
endmodule

```

Example 3—The following example shows usage of chained nested conditional compilation directives:

```

module test;
  `ifdef first_block
    `ifndef second_nest
      initial $display("first_block is defined");
    `else
      initial $display("first_block and second_nest defined");
    `endif
  `elsif second_block
    initial $display("second_block defined, first_block is not");
  `else
    `ifndef last_result

```

```

        initial $display("first_block, second_block,",
            " last_result not defined.");
    `elsif real_last
        initial $display("first_block, second_block not defined,",
            " last_result and real_last defined.");
    `else
        initial $display("Only last_result defined!");
    `endif
`endif
endmodule

```

22.7 `timescale

This directive specifies the time unit and time precision of the design elements that follow it. The time unit is the unit of measurement for time values such as the simulation time and delay values.

To use design elements with different time units in the same design, the following timescale constructs are useful:

- The **timeunit** and **timeprecision** keywords to specify the unit of measurement for time and precision of time in specific design elements (see [3.14.2.2](#))
- The ``timescale` compiler directive to specify the unit of measurement for time and precision of time in the design elements that follow the directive
- The `$printtimescale` system task to display the time unit and precision of a design element
- The `$time` and `$realtime` system functions, the `$timeformat` system task, and the `%t` format specification to specify how time information is reported

The ``timescale` compiler directive specifies the default unit of measurement for time and delay values and the degree of accuracy for delays in all design elements that follow this directive, and that do not have **timeunit** and **timeprecision** constructs specified within the design element, until another ``timescale` compiler directive is read.

See [3.14.2.3](#) for the precedence rules of the **timeunit** and **timeprecision** constructs versus the ``timescale` directive.

If there is no ``timescale` specified or it has been reset by a ``resetall` directive, the default time unit and precision are tool-specific.

The syntax for the ``timescale` directive is given in [Syntax 22-6](#).

```

timescale_compiler_directive ::=
    `timescale time_unit / time_precision

```

Syntax 22-6—Syntax for timescale compiler directive (not in [Annex A](#))

The *time_unit* argument specifies the unit of measurement for times and delays.

The *time_precision* argument specifies how delay values are rounded before being used in simulation.

The *time_precision* argument shall be at least as precise as the *time_unit* argument; it cannot specify a longer unit of time than *time_unit*.

The integers in these arguments specify an order of magnitude for the size of the value; the valid integers are 1, 10, and 100. The character strings represent units of measurement; the valid character strings are *s*, *ms*, *us*, *ns*, *ps*, and *fs*.

See [3.14](#) for the semantics and effects of *time_unit* and *time_precision*.

The following example shows how this directive is used:

```
`timescale 1 ns / 1 ps
```

Here, all time values in the design elements that follow the directive are multiples of 1 ns because the *time_unit* argument is “1 ns.” Delays are rounded to real numbers with three decimal places—or precise to within one thousandth of a nanosecond—because the *time_precision* argument is “1 ps,” or one thousandth of a nanosecond.

Consider the following example:

```
`timescale 10 us / 100 ns
```

The time values in the design elements that follow this directive are multiples of 10 us because the *time_unit* argument is “10 us.” Delays are rounded to within one tenth of a microsecond because the *time_precision* argument is “100 ns,” or one tenth of a microsecond.

The following example shows a ``timescale` directive in the context of a module:

```
`timescale 10 ns / 1 ns
module test;
  logic set;
  parameter d = 1.55;

  initial begin
    #d set = 0;
    #d set = 1;
  end
endmodule
```

The ``timescale 10 ns / 1 ns` compiler directive specifies that the time unit for module `test` is 10 ns. As a result, the time values in the module are multiples of 10 ns, rounded to the nearest 1 ns; therefore, the value stored in parameter `d` is scaled to a delay of 16 ns. In other words, the value 0 is assigned to variable `set` at simulation time 16 ns (1.6×10 ns), and the value 1 at simulation time 32 ns.

Parameter `d` retains its value no matter what timescale is in effect.

These simulation times are determined as follows:

- The value of parameter `d` is rounded from 1.55 to 1.6 according to the time precision.
- The time unit of the module is 10 ns, and the precision is 1 ns; therefore, the delay of parameter `d` is scaled from 1.6 to 16.
- The assignment of 0 to variable `set` is scheduled at simulation time 16 ns, and the assignment of 1 at simulation time 32 ns. The time values are not rounded when the assignments are scheduled.

22.8 ``default_nettype`

The directive ``default_nettype` controls the net type created for implicit net declarations (see [6.10](#)). It can be used only outside design elements. Multiple ``default_nettype` directives are allowed. The latest

occurrence of this directive in the source controls the type of nets that will be implicitly declared. [Syntax 22-7](#) contains the syntax of the directive.

```
default_nettype_compiler_directive ::=
    `default_nettype default_nettype_value
default_nettype_value ::= wire | tri | tri0 | tri1 | wand | triand | wor | trior | trireg | uwire | none
```

Syntax 22-7—Syntax for default_nettype compiler directive (not in [Annex A](#))

When no ``default_nettype` directive is present or if the ``resetall` directive is specified, implicit nets are of type **wire**. When the ``default_nettype` is set to `none`, all nets shall be explicitly declared. If a net is not explicitly declared, an error is generated.

22.9 ``unconnected_drive` and ``nounconnected_drive`

All unconnected input ports of a module, program or interface appearing between the directives ``unconnected_drive` and ``nounconnected_drive` are pulled up or pulled down instead of the normal default.

The directive ``unconnected_drive` takes one of two arguments—`pull11` or `pull10`. When `pull11` is specified, all unconnected input ports are automatically pulled up. When `pull10` is specified, unconnected ports are pulled down. It is advisable to pair each ``unconnected_drive` with a ``nounconnected_drive`, but it is not required. The latest occurrence of either directive in the source controls what happens to unconnected ports. These directives shall be specified outside the design element declarations.

The ``resetall` directive includes the effects of a ``nounconnected_drive` directive.

22.10 ``celldefine` and ``endcelldefine`

The directives ``celldefine` and ``endcelldefine` tag modules as *cell modules*. Cells are used by certain PLI routines and may be useful for applications such as delay calculations. It is advisable to pair each ``celldefine` with an ``endcelldefine`, but it is not required. The latest occurrence of either directive in the source controls whether modules are tagged as cell modules. More than one of these pairs may appear in a single source description.

These directives may appear anywhere in the source description, but it is recommended that the directives be specified outside any design elements.

The ``resetall` directive includes the effects of a ``endcelldefine` directive.

22.11 ``pragma`

The ``pragma` directive is a structured specification that alters interpretation of the SystemVerilog source. The specification introduced by this directive is referred to as a *pragma*. The effect of pragmas other than those specified in this standard is implementation-specific. The syntax for the ``pragma` directive is given in [Syntax 22-8](#).

```
pragma ::=  
    `pragma pragma_name [ pragma_expression { , pragma_expression } ]  
pragma_name ::= simple_identifier  
pragma_expression ::=  
    pragma_keyword  
    | pragma_keyword = pragma_value  
    | pragma_value  
pragma_value ::=  
    ( pragma_expression { , pragma_expression } )  
    | number  
    | string  
    | identifier  
pragma_keyword ::= simple_identifier
```

Syntax 22-8—Syntax for pragma compiler directive (not in [Annex A](#))

The pragma specification is identified by the *pragma_name*, which follows the ``pragma` directive. The *pragma_name* is followed by an optional list of *pragma_expressions*, which qualify the altered interpretation indicated by the *pragma_name*. Unless otherwise specified, pragma directives for *pragma_names* that are not recognized by an implementation shall have no effect on interpretation of the SystemVerilog source text.

22.11.1 Standard pragmas

The `reset` and `resetall` pragmas shall restore the default values and state of *pragma_keywords* associated with the affected pragmas. These default values shall be the values that the tool defines before any SystemVerilog text has been processed. The `reset` pragma shall reset the state for all *pragma_names* that appear as *pragma_keywords* in the directive. The `resetall` pragma shall reset the state of all *pragma_names* recognized by the implementation.

22.12 ``line`

It is important for SystemVerilog tools to keep track of the filenames of the SystemVerilog source files and the line numbers in the files. This information can be used for error messages or source code debugging and can be accessed by the Programming Language Interface (PLI) (see [Clause 36](#)).

In many cases, however, the SystemVerilog source is preprocessed by some other tool, and the line and file information of the original source file can be lost because the preprocessor might add additional lines to the source code file, combine multiple source code lines into one line, concatenate multiple source files, and so on.

The ``line` compiler directive can be used to specify the original source code line number and filename. This allows the location in the original file to be maintained if another process modifies the source. After the newline number and filename are specified, the compiler can correctly refer to the original source location. However, a tool is not required to produce ``line` directives. These directives are not intended to be inserted manually into the code, although they can be.

The compiler shall maintain the current line number and filename of the file being compiled. The ``line` directive shall set the line number and filename of the following line to those specified in the directive. The directive can be specified anywhere within the SystemVerilog source description. However, only white

space may appear on the same line as the `\line` directive. Comments are not allowed on the same line as a `\line` directive. All parameters in the `\line` directive are required. The results of this directive are not affected by the `\resetall` directive.

The syntax for the `\line` compiler directive is given in [Syntax 22-9](#).

```
line_compiler_directive ::=
    \line number " filename " level
```

Syntax 22-9—Syntax for line compiler directive (not in [Annex A](#))

The *number* parameter shall be a positive integer that specifies the new line number of the following text line. The *filename* parameter shall be a string literal that is treated as the new name of the file. The filename can also be a full or relative path name. The *level* parameter shall be 0, 1, or 2. The value 1 indicates that the following line is the first line after an include file has been entered. The value 2 indicates that the following line is the first line after an include file has been exited. The value 0 indicates any other line.

For example:

```
\line 3 "orig.v" 2
// This line is line 3 of orig.v after exiting include file
```

As the compiler processes the remainder of the file and new files, the line number shall be incremented as each line is read, and the name shall be updated to the new current file being processed. The line number shall be reset to 1 at the beginning of each file. When beginning to read include files, the current line and filename shall be stored for restoration at the termination of the include file. The updated line number and filename information shall be available for PLI access. The mechanism of library searching is not affected by the effects of the `\line` compiler directive.

22.13 `__FILE__` and `__LINE__`

`__FILE__` expands to the name of the current input file, in the form of a string literal. This is the path by which a tool opened the file, not the short name specified in `\include` or as a tool's input file name argument. The format of this path name may be implementation dependent.

`__LINE__` expands to the current input line number, in the form of a simple decimal number.

`__FILE__` and `__LINE__` are useful in generating an error message to report a problem; the message can state the source line at which the problem was detected.

For example:

```
$display("Internal error: null handle at %s, line %d.",
    __FILE__, __LINE__);
```

An `\include` directive changes the expansions of `__FILE__` and `__LINE__` to correspond to the included file. At the end of that file, when processing resumes on the input file that contained the `\include` directive, the expansions of `__FILE__` and `__LINE__` revert to the values they had before the `\include` (but `__LINE__` is then incremented by one as processing moves to the line after the `\include`).

A `\line` directive changes `__LINE__`, and may change `__FILE__` as well.

22.14 ``begin_keywords`, ``end_keywords`

A pair of directives, ``begin_keywords` and ``end_keywords`, can be used to specify what identifiers are reserved as keywords within a block of source code, based on a specific version of IEEE Std 1364 or IEEE Std 1800.

The syntax of the ``begin_keywords` and ``end_keywords` directives is given in [Syntax 22-10](#).

```
keywords_directive ::= `begin_keywords "version_specifier"  
version_specifier ::=  
    1800-2009  
    | 1800-2005  
    | 1364-2005  
    | 1364-2001  
    | 1364-2001-noconfig  
    | 1364-1995  
endkeywords_directive ::= `end_keywords
```

Syntax 22-10—Syntax for `begin_keywords` and `end_keywords` compiler directives (not in [Annex A](#))

The *version_specifier* specifies that only the identifiers listed as reserved keywords in the specified version are considered to be reserved words. The ``begin_keywords` and ``end_keywords` directives only specify the set of identifiers that are reserved as keywords. The directives do not affect the semantics, tokens, and other aspects of the SystemVerilog language.

Implementations and other standards are permitted to extend the ``begin_keywords` directive with custom version specifiers. It shall be an error if an implementation does not recognize the *version_specifier* used with the ``begin_keywords` directive.

The ``begin_keywords` and ``end_keywords` directives can only be specified outside a design element (see [3.2](#)). The ``begin_keywords` directive affects all source code that follows the directive, even across source code file boundaries, until the matching ``end_keywords` directive or the end of the compilation unit. The results of these directives are not affected by the ``resetall` directive.

The ``begin_keywords...`end_keywords` directive pair can be nested. Each nested pair is stacked so that when an ``end_keywords` directive is encountered, the implementation returns to using the *version_specifier* that was in effect prior to the matching ``begin_keywords` directive.

If no ``begin_keywords` directive is specified, then the reserved keyword list shall be the implementation's default set of keywords. The default set of reserved keywords used by an implementation shall be implementation dependent. For example, an implementation based on IEEE Std 1800-2005 would most likely use the IEEE 1800-2005 set of reserved keywords as its default, whereas an implementation based on IEEE Std 1364-2001 would most likely use the IEEE 1364-2001 set of reserved keywords as its default. Implementations may provide other mechanisms for specifying the set of reserved keywords to be used as the default. One possible use model might be for an implementation to use invocation options to specify its default set of reserved keywords. Another possible use model might be the use of source file name extensions for determining a default set of reserved keywords to be used for each source file.

22.14.1 Examples

In the example below, it is assumed that the definition of module `m1` does not have a ``begin_keywords` directive specified prior to the module definition. Without this directive, the set of reserved keywords in effect for this module shall be the implementation's default set of reserved keywords.

```

module m1; // module definition with no `begin_keywords directive
...
endmodule

```

The following example specifies a ``begin_keywords "1364-2001"` directive. The source code within the module uses the identifier `logic` as a variable name. The ``begin_keywords` directive would be necessary in this example if an implementation uses IEEE Std 1800-2005 as its default set of keywords because `logic` is a reserved keyword in SystemVerilog. Specifying that the "1364-1995" or "1364-2005" Verilog keyword lists should be used would also work with this example.

```

`begin_keywords "1364-2001" // use IEEE Std 1364-2001 Verilog keywords
module m2 (...);
  reg [63:0] logic; // OK: "logic" is not a keyword in 1364-2001
  ...
endmodule
`end_keywords

```

The next example is the same code as the previous example, except that it explicitly specifies that the IEEE Std 1800-2005 SystemVerilog keywords should be used. This example shall result in an error because `logic` is reserved as a keyword in this standard.

```

`begin_keywords "1800-2005" // use IEEE Std 1800-2005 SystemVerilog keywords
module m2 (...);
  reg [63:0] logic; // ERROR: "logic" is a keyword in 1800-2005
  ...
endmodule
`end_keywords

```

The example below specifies a ``begin_keywords` directive on an **interface** declaration. The directive specifies that an implementation shall use the set of reserved keywords specified in this standard.

```

`begin_keywords "1800-2005" // use IEEE Std 1800-2005 SystemVerilog keywords
interface if1 (...);
  ...
endinterface
`end_keywords

```

The next example is nearly identical to the one above, except that the ``begin_keywords` directive specifies that the IEEE Std 1364-2005 Verilog set of keywords are to be used. This example shall result in errors because the identifiers **interface** and **endinterface** are not reserved keywords in IEEE Std 1364-2005.

```

`begin_keywords "1364-2005" // use IEEE Std 1364-2005 Verilog keywords
interface if2 (...); // ERROR: "interface" is not a keyword in 1364-2005
  ...
endinterface // ERROR: "endinterface" is not a keyword in 1364-2005
`end_keywords

```

22.14.2 IEEE Std 1364-1995 keywords

The *version_specifier* "1364-1995" specifies that the identifiers listed as reserved keywords in IEEE Std 1364-1995 are considered to be reserved words. These identifiers are listed in [Table 22-1](#).

Table 22-1—IEEE Std 1364-1995 reserved keywords

always	ifnone	rpmos
and	initial	rtran
assign	inout	rtranif0
begin	input	rtranif1
buf	integer	scalared
bufif0	join	small
bufif1	large	specify
case	macromodule	specparam
casex	medium	strong0
casez	module	strong1
cmos	nand	supply0
deassign	negedge	supply1
default	nmos	table
defparam	nor	task
disable	not	time
edge	notif0	tran
else	notif1	tranif0
end	or	tranif1
endcase	output	tri
endmodule	parameter	tri0
endfunction	rpmos	tri1
endprimitive	posedge	triand
endspecify	primitive	trior
endtable	pull0	trireg
endtask	pull1	vectored
event	pullup	wait
for	pulldown	wand
force	rcmos	weak0
forever	real	weak1
fork	realtime	while
function	reg	wire
highz0	release	wor
highz1	repeat	xnor
if	rnmos	xor

22.14.3 IEEE Std 1364-2001 keywords

The *version_specifier* "1364-2001" specifies that the identifiers listed as reserved keywords in IEEE Std 1364-2001 are considered to be reserved words. This version includes the identifiers listed in version "1364-1995" (see [Table 22-1](#)) plus all identifiers in listed in [Table 22-2](#).

Table 22-2—IEEE Std 1364-2001 additional reserved keywords

automatic	genvar	noshowcancelled
cell	ifnone	pulsestyle_ondetect
config	incdir	pulsestyle_onevent
design	include	showcancelled
endconfig	liblist	signed
endgenerate	library	unsigned
generate	localparam	use

22.14.4 IEEE Std 1364-2001-noconfig keywords

The *version_specifier* "1364-2001-noconfig" behaves similarly to the "1364-2001" *version_specifier*, with the exception that the following identifiers are excluded from the reserved list in [Table 22-2](#):

- cell
- config
- design
- endconfig
- incdir
- include
- instance
- liblist
- library
- use

22.14.5 IEEE Std 1364-2005 keywords

The *version_specifier* "1364-2005" specifies that the identifiers listed as reserved keywords in IEEE Std 1364-2005 are considered to be reserved words. This version includes the identifiers listed in versions "1364-1995" (see [Table 22-1](#)) and "1364-2001" (see [Table 22-2](#)) plus the additional identifiers listed in [Table 22-3](#).

Table 22-3—IEEE Std 1364-2005 additional reserved keywords

uwire

22.14.6 IEEE Std 1800-2005 keywords

The *version_specifier* "1800-2005" specifies that the identifiers listed as reserved keywords in the IEEE Std 1800-2005 are considered to be reserved words. This version includes the identifiers listed in versions "1364-1995" (see [Table 22-1](#)), "1364-2001" (see [Table 22-2](#)) and "1364-2005" (see [Table 22-3](#)) plus the additional identifiers listed in [Table 22-4](#).

Table 22-4—IEEE Std 1800-2005 additional reserved keywords

alias	endsequence	pure
always_comb	enum	rand
always_ff	expect	randc
always_latch	export	randcase
assert	extends	randsequence
assume	extern	ref
before	final	return
bind	first_match	sequence
bins	foreach	shortint
binsof	forkjoin	shortreal
bit	iff	solve
break	ignore_bins	static
byte	illegal_bins	string
chandle	import	struct
class	inside	super
clocking	int	tagged
const	interface	this
constraint	intersect	throughout
context	join_any	timeprecision
continue	join_none	timeunit
cover	local	type
covergroup	logic	typedef
coverpoint	longint	union
cross	matches	unique
dist	modport	var
do	new	virtual
endclass	null	void
endclocking	package	wait_order
endgroup	packed	wildcard
endinterface	priority	with
endpackage	program	within
endprogram	property	
endproperty	protected	

22.14.7 IEEE Std 1800-2009 keywords

The version_specifier "1800-2009" specifies that the identifiers listed as reserved keywords in IEEE Std 1800-2009 are considered to be reserved words. This version includes the identifiers listed in versions "1364-1995" (see [Table 22-1](#)), "1364-2001" (see [Table 22-2](#)), "1364-2005" (see [Table 22-3](#)), and "1800-2005" (see [Table 22-4](#)) plus the additional identifiers listed in [Table 22-5](#).

Table 22-5—IEEE Std 1800-2009 additional reserved keywords

accept_on	reject_on	sync_accept_on
checker	restrict	sync_reject_on
endchecker	s_always	unique0
eventually	s_eventually	until
global	s_nexttime	until_with
implies	s_until	untyped
let	s_until_with	weak
nexttime	strong	

The full set of reserved identifiers for the current version of this standard is listed in [Annex B](#), which reflects the combination of all version tables.

Part Two: Hierarchy Constructs

23. Modules and hierarchy

23.1 General

This clause describes the following:

- The formal syntax for module definitions
- The formal syntax for module instantiations
- Nested modules
- Extern modules
- Hierarchical name referencing
- Scope rules
- Parameter redefinition
- Elaboration considerations
- Binding

23.2 Module definitions

The module construct is the basic building block of a SystemVerilog design. The primary purpose of a module is to encapsulate the data, functionality and timing of digital hardware objects. A module can represent low-level digital components, such as a simple AND gate, or an entire complex digital system. A module can represent function and timing at a very detailed level, at a very abstract level, or as a mix of abstract and detail levels. Modules can instantiate other design elements, thereby creating a design hierarchy.

A module definition shall be enclosed between the keywords **module** and **endmodule**. The identifier following the keyword **module** shall be the name of the module being defined. The keyword **macromodule** can be used interchangeably with the keyword **module** to define a module. An implementation may choose to treat module definitions beginning with the **macromodule** keyword differently.

23.2.1 Module header definition

The module header defines the following:

- The name of the module
- The port list of the module
- The direction and size of each port
- The type of data passed through each port
- The parameter constants of the module
- A package import list of the module
- The default lifetime (static or automatic) of subroutines defined within the module

There are two styles of module header definitions, the *non-ANSI header* and the *ANSI header*.

The *non-ANSI header* style separates the definition of the module header from the declarations of the module ports and internal data. The informal syntax of a non-ANSI style module header is as follows:

```
module_name ( port_list ) ;  
    parameter_declaration_list  
    port_direction_and_size_declarations  
    port_type_declarations
```

The module header definition is syntactically completed by the semicolon after the closing parenthesis of the port list. Declarations that define the characteristics of the ports (direction, size, data type, signedness, etc.) are local definitions within the module.

The *ANSI header* style makes the declarations of the port characteristics part of the module header (which is still terminated by a semicolon). The informal general syntax of an ANSI style module header is as follows:

```
module_name #( parameter_port_list )
             ( port_direction_and_type_list ) ;
```

The formal syntax for module declarations is shown in [Syntax 23-1](#).

```
module_declaration ::= //from A.1.2
  module_nonansi_header [ timeunits_declaration ] { module_item }
  | endmodule [ : module_identifier ]
  | module_ansi_header [ timeunits_declaration ] { non_port_module_item }
  | endmodule [ : module_identifier ]
  | { attribute_instance } module_keyword [ lifetime ] module_identifier ( .* ) ;
  | [ timeunits_declaration ] { module_item } endmodule [ : module_identifier ]
  | extern module_nonansi_header
  | extern module_ansi_header
module_nonansi_header ::=
  { attribute_instance } module_keyword [ lifetime ] module_identifier
  { package_import_declaration } [ parameter_port_list ] list_of_ports ;
module_ansi_header ::=
  { attribute_instance } module_keyword [ lifetime ] module_identifier
  { package_import_declaration }1 [ parameter_port_list ] [ list_of_port_declarations ] ;
module_keyword ::= module | macromodule
timeunits_declaration ::=
  timeunit time_literal [ / time_literal ] ;
  | timeprecision time_literal ;
  | timeunit time_literal ; timeprecision time_literal ;
  | timeprecision time_literal ; timeunit time_literal ;
parameter_port_list ::= //from A.1.3
  # ( list_of_param_assignments { , parameter_port_declaration } )
  | # ( parameter_port_declaration { , parameter_port_declaration } )
  | # ( )
parameter_port_declaration ::=
  parameter_declaration
  | local_parameter_declaration
  | data_type list_of_param_assignments
  | type list_of_type_assignments
```

1) A package_import_declaration in a module_ansi_header, interface_ansi_header, or program_ansi_header shall be followed by a parameter_port_list or list_of_port_declarations, or both.

Syntax 23-1—Module declaration syntax (excerpt from [Annex A](#))

23.2.2 Port declarations

Ports provide a means of interconnecting a hardware description consisting of modules and primitives. For example, module A can instantiate module B, using port connections appropriate to module A. These port names can differ from the names of the internal nets and variables specified in the definition of module B.

A port can be a declaration of an interface, an event, or a variable or net of any allowed data type, including an array, a structure, or a union.

```

typedef struct {
    bit isfloat;
    union { int i; shortreal f; } n;
} tagged_st; // named structure

module mh1 (input var int in1,
           input var shortreal in2,
           output tagged_st out);
...
endmodule

```

Implementations may limit the maximum number of ports in a module definition, but the limit shall be at least 256.

23.2.2.1 Non-ANSI style port declarations

In the non-ANSI style of module header, separate declarations are used for the module *list_of_ports* and the declarations of the port characteristics (direction, size, signedness) and the type of data passed through the ports.

The syntax for the non-ANSI style *list_of_ports* module header declaration is given in [Syntax 23-2](#).

```

module_nonansi_header ::= // from A.1.2
    { attribute_instance } module_keyword [ lifetime ] module_identifier
    { package_import_declaration } [ parameter_port_list ] list_of_ports ;
list_of_ports ::= ( port { , port } )
port ::=
    [ port_expression ]
    | . port_identifier ( [ port_expression ] )
port_expression ::=
    port_reference
    | { port_reference { , port_reference } }
port_reference ::=
    port_identifier constant_select

```

Syntax 23-2—Non-ANSI style module header declaration syntax (excerpt from [Annex A](#))

The port reference for each port in the *list_of_ports* in the module header can be one of the following:

- A simple identifier or escaped identifier
- A bit-select of a vector declared within the module
- A part-select of a vector declared within the module
- A concatenation of any of the above

The port expression is optional because ports can be defined that do not connect to anything internal to the module. Once a port has been defined, there shall not be another port definition with this same name.

The first type of module port, with only a *port_expression*, is an *implicit port*.

The second type is the *explicit port*. This explicitly specifies the *port_identifier* used for connecting module instance ports by name (see [23.3.2.2](#)) and the *port_expression* that contains identifiers declared inside the module as described below. Named port connections shall not be used for implicit ports unless the *port_expression* is a simple identifier or escaped identifier, which shall be used as the port name.

Each *port_identifier* in a *port_expression* in the list of ports for the module declaration shall also be declared in the body of the module as one of the following port declarations: **input**, **output**, **inout** (bidirectional), **ref**, or as an interface port (see [Clause 25](#)). This is in addition to any net or variable declaration for a particular *port_identifier*.

The syntax for non-ANSI style module *port_declarations* is given in [Syntax 23-3](#).

```

port_declaration ::= //from A.1.3
  { attribute_instance } inout_declaration
  | { attribute_instance } input_declaration
  | { attribute_instance } output_declaration
  | { attribute_instance } ref_declaration
  | { attribute_instance } interface_port_declaration

inout_declaration ::= //from A.2.1.2
  inout net_port_type list_of_port_identifiers

input_declaration ::=
  input net_port_type list_of_port_identifiers
  | input variable_port_type list_of_variable_identifiers

output_declaration ::=
  output net_port_type list_of_port_identifiers
  | output variable_port_type list_of_variable_port_identifiers

ref_declaration ::= ref variable_port_type list_of_port_identifiers

interface_port_declaration ::=
  interface_identifier list_of_interface_identifiers
  | interface_identifier . modport_identifier list_of_interface_identifiers

```

Syntax 23-3—Non-ANSI style port declaration syntax (excerpt from [Annex A](#))

If a port declaration includes a net or variable type, then the port is considered completely declared, and it is an error for the port to be declared again in a variable or net data type declaration. Because of this, all other aspects of the port shall be declared in such a port declaration, including the signed and range definitions if needed.

If a port declaration does not include a net or variable type, then the port can be again declared in a net or variable declaration. If the net or variable is declared as a vector, the range specification between the two declarations of a port shall be identical. Once a name is used in a port declaration, it shall not be declared again in another port declaration or in a data type declaration.

For example:

```
input  aport;    // First declaration - okay
```



```

input  aport;      // Error - multiple declaration, port declaration
output aport;      // Error - multiple declaration, port declaration

```

The signed attribute can be attached either to a port declaration or the corresponding net or variable declaration or to both. If either the port or the net/variable is declared as signed, then the other shall also be considered signed.

Nets connected to ports without an explicit net declaration shall be considered unsigned, unless the port is declared as signed. Other implicit nets (see [6.10](#)) shall be considered unsigned.

Using the non-ANSI header style with a port list followed by separate declarations for each port allows flexibility on the internal data to be passed through ports.

Example 1—Implicitly named ports connected to internal nets or variables of the same name (non-ANSI style module header)

```

module test(a,b,c,d,e,f,g,h);
  input  [7:0] a;          // no explicit net declaration - net is unsigned
  input  [7:0] b;
  input signed [7:0] c;
  input signed [7:0] d;    // no explicit net declaration - net is signed
  output [7:0] e;          // no explicit net declaration - net is unsigned
  output [7:0] f;
  output signed [7:0] g;
  output signed [7:0] h;  // no explicit net declaration - net is signed

  wire signed [7:0] b; // port b inherits signed attribute from net decl.
  wire [7:0] c;        // net c inherits signed attribute from port
  logic signed [7:0] f; // port f inherits signed attribute from logic decl.
  logic [7:0] g;       // logic g inherits signed attribute from port

endmodule

```

Example 2—Ports connected to internal nets of a different name (non-ANSI style module header)

```

module complex_ports ( {c,d}, .e(f) );
  // Nets {c,d} receive the first port bits.
  // Name 'f' is declared inside the module.
  // Name 'e' is defined outside the module.
  // Cannot use named port connections of first port.

```

Example 3—Ports connected to split of internal vector (non-ANSI style module header)

```

module split_ports (a[7:4], a[3:0]);
  // First port is upper 4 bits of 'a'.
  // Second port is lower 4 bits of 'a'.
  // Cannot use named port connections because
  // of part-select port 'a'.

```

Example 4—Two ports with different names connected to same internal net (non-ANSI style module header)

```

module same_port (.a(i), .b(i));
  // Name 'i' is declared inside the module as an inout port.
  // Names 'a' and 'b' are defined for port connections.

```

Example 5—Explicitly named port connected to concatenation of internal nets or variables (non-ANSI style module header)

```

module renamed_concat (.a({b,c}), f, .g(h[1]));
    // Names 'b', 'c', 'f', 'h' are defined inside the module.
    // Names 'a', 'f', 'g' are defined for port connections.
    // Can use named port connections.

```

Example 6—Two implicitly named ports connected to same internal net (non-ANSI style module header)

```

module same_input (a,a);
input a;           // This is legal. The inputs are tied together.

```

Example 7—Explicitly named port with mix of input and output directions (non-ANSI style module header)

```

module mixed_direction (.p({a, e}));
input a;           // p contains both input and output directions.
output e;

```

23.2.2.2 ANSI style list of port declarations

An alternate syntax that minimizes the duplication of data can be used to specify the ports of a module. Each module shall be declared either entirely with the *list_of_ports* syntax as described in [23.2.2.1](#) or entirely with the *list_of_port_declarations* syntax as described in this subclause.

The syntax for ANSI style *list_of_port_declarations* module header is given in [Syntax 23-4](#).

```

module_ansi_header ::=                                     //from A.1.2
    { attribute_instance } module_keyword [ lifetime ] module_identifier
        { package_import_declaration }1 [ parameter_port_list ] [ list_of_port_declarations ] ;
list_of_port_declarations2 ::=                             //from A.1.3
    ( [ { attribute_instance } ansi_port_declaration { , { attribute_instance } ansi_port_declaration } ] )
ansi_port_declaration ::=
    [ net_port_header | interface_port_header ] port_identifier { unpacked_dimension }
        [ = constant_expression ]
    | [ variable_port_header ] port_identifier { variable_dimension } [ = constant_expression ]
    | [ port_direction ] . port_identifier ( [ expression ] )
net_port_header ::= [ port_direction ] net_port_type
variable_port_header ::= [ port_direction ] variable_port_type
interface_port_header ::=
    interface_identifier [ . modport_identifier ]
    | interface [ . modport_identifier ]
port_direction ::= input | output | inout | ref
net_port_type15 ::=                                       //from A.2.2.1
    [ net_type ] data_type_or_implicit
variable_port_type ::= var_data_type
var_data_type ::= data_type | var data_type_or_implicit

```

²) The *list_of_port_declarations* syntax is explained in [23.2.2](#), which also imposes various semantic restrictions, e.g., a **ref** port shall be of a variable type and an **inout** port shall not be. It shall be illegal to initialize a port that is not a variable **output** port or to specify a default value for a port that is not an **input** port.

- 15) When a `net_port_type` contains a `data_type`, it shall only be legal to omit the explicit `net_type` when declaring an **inout** port.
- 1) A `package_import_declaration` in a `module_ansi_header`, `interface_ansi_header`, or `program_ansi_header` shall be followed by a `parameter_port_list` or `list_of_port_declarations`, or both.

Syntax 23-4—ANSI style `list_of_port_declarations` syntax (excerpt from [Annex A](#))

Each port declaration provides the complete information about the port. The port's direction, width, net or variable type, and signedness are completely described. The same syntax for input, inout, and output declarations is used in the module header as would be used for the list of port style declaration, except the *list_of_port_declarations* is included in the module header rather than separately (after the `;` that terminates the module header).

For example:

As an example, the module named `test` listed in [23.2.2.1 Example 1](#) could alternatively be declared as follows:

```
module test (  
    input [7:0] a,  
    input signed [7:0] b, c, d, // Multiple ports that share all  
                                // attributes can be declared together.  
    output [7:0] e, // Every attribute of the declaration  
                  // must be in the one declaration.  
    output var signed [7:0] f, g,  
    output signed [7:0] h) ;  
  
    // It is illegal to redeclare any ports of  
    // the module in the body of the module.  
endmodule
```

Generic interface ports (see [25.3.3](#)) cannot be declared using the non-ANSI style *list_of_ports* syntax (see [23.2.2.1](#)). Generic interface ports can only be declared using the ANSI style *list_of_port_declarations* syntax.

```
module cpuMod(interface d, interface j);  
    ...  
endmodule
```

ANSI style port declarations can be explicitly named, allowing elements of arrays and structures, concatenations of elements, and assignment pattern expressions of elements declared in a module, interface, or program to be specified on the port list.

Like explicitly named ports in a module port declaration, port identifiers exist in their own name space for each port list. When a port item is just a simple port identifier, that identifier is used as both a reference to an interface item and a port identifier. Once a port identifier has been defined, there shall not be another port definition with this same name.

For example:

```
module mymod (  
    output .P1(r[3:0]),  
    output .P2(r[7:4]),  
    ref .Y(x),  
    input R );
```

```

    logic [7:0] r;
    int x;
    ...
endmodule

```

The self-determined type of the port expression becomes the type for the port. The port expression shall not be considered an assignment-like context. The port expression shall resolve to a legal expression for type of module port (see [23.3.3](#)). The port expression is optional because ports can be defined that do not connect to anything internal to the port.

23.2.2.3 Rules for determining port kind, data type and direction

Within this subclause, the term *port kind* is used to mean any of the net type keywords, or the keyword **var**, which are used to explicitly declare a port of one of these kinds. If these keywords are omitted in a port declaration, there are default rules for determining the port kind, as specified below.

Within this subclause, the term *data type* means both *explicit* and *implicit* data type declarations and does not include unpacked dimensions. An explicit data type declaration uses the *data_type* syntax. An implicit data type declaration uses the *implicit_data_type* syntax and includes only a signedness keyword and/or packed dimensions. An implicit data type declaration implies a **net** unless the **var** keyword is used. Unpacked dimensions shall not be inherited from the previous port declaration and must be repeated for each port with the same dimensions.

For the first port in the port list:

- If the direction, port kind, and data type are all omitted, then the port shall be assumed to be a member of a non-ANSI style *list_of_ports*, and port direction and type declarations shall be declared after the port list.

Otherwise:

- If the direction is omitted, it shall default to **inout**.
- If the port kind is omitted, it shall be determined as specified below.
- If the data type is omitted, it shall default to **logic**.

If the port kind is omitted:

- For **input** and **inout** ports, the port shall default to a net of default net type. The default net type can be changed using the ``default_nettype` compiler directive (see [22.8](#)).
- For **output** ports, the default port kind depends on how the data type is specified:
 - If the data type is omitted or declared with the *implicit_data_type* syntax, the port kind shall default to a net of default net type.
 - If the data type is declared with the explicit *data_type* syntax, the port kind shall default to variable.
- A **ref** port is always a variable.

Examples:

```

// Declarations must follow the port list because the first port
// does not have a direction, kind, or type specified
module mh_nonansi(x, y);
    input wire x;
    output tri0 y;
    ...
endmodule

```

```
module mh0 (wire x);           // inout wire logic x
module mh1 (integer x);       // inout wire integer x
module mh2 (inout integer x); // inout wire integer x
module mh3 ([5:0] x);         // inout wire logic [5:0] x
module mh4 (var x);           // ERROR: direction defaults to inout,
                               // which cannot be var
module mh5 (input x);         // input wire logic x
module mh6 (input var x);     // input var logic x
module mh7 (input var integer x); // input var integer x
module mh8 (output x);       // output wire logic x
module mh9 (output var x);    // output var logic x
module mh10(output signed [5:0] x); // output wire logic signed [5:0] x
module mh11(output integer x); // output var integer x
module mh12(ref [5:0] x);     // ref var logic [5:0] x
module mh13(ref x [5:0]);     // ref var logic x [5:0]
```

For subsequent ports in the port list:

- If the direction, port kind and data type are all omitted, then they shall be inherited from the previous port.

Otherwise:

- If the direction is omitted, it shall be inherited from the previous port.
- If the port kind is omitted, it shall be determined as specified above.
- If the data type is omitted, it shall default to **logic**.

Examples:

```
module mh14(wire x, y[7:0]);   // inout wire logic x
                               // inout wire logic y[7:0]
module mh15(integer x, signed [5:0] y); // inout wire integer x
                               // inout wire logic signed [5:0] y
module mh16([5:0] x, wire y); // inout wire logic [5:0] x
                               // inout wire logic y
module mh17(input var integer x, wire y); // input var integer x
                                           // input wire logic y
module mh18(output var x, input y); // output var logic x
                                           // input wire logic y
```

```

module mh19(output signed [5:0] x, integer y);
                                     // output wire logic signed [5:0] x
                                     // output var integer y

module mh20(ref [5:0] x, y);          // ref var logic [5:0] x
                                     // ref var logic [5:0] y

module mh21(ref x [5:0], y);        // ref var logic x [5:0]
                                     // ref var logic y

```

23.2.2.4 Default port values

A module declaration may specify a default value for each singular input port. These default values shall be constant expressions evaluated in the scope of the module where they are defined, not in the scope of the instantiating module.

The informal syntax to declare a default input port value in a module is as follows:

```

module module_name (
    ...,
    [ input ] [ type ] port_identifier = constant_expression,
    ... ) ;

```

Defaults can be specified only for input ports and only in ANSI style declarations.

When the module is instantiated, input ports with default values can be omitted from the instantiation, and the compiler shall insert the corresponding default values. If a connection is not specified for an input port and the port does not have a default value, then, depending on the connection style (ordered list, named connections, implicit named connections, or implicit .* connections), the port shall either be left unconnected or result in an error, as discussed in [23.3.2.1](#) through [23.3.2.4](#).

The following example illustrates default port semantics and parameter scope resolution:

```

parameter logic [7:0] My_DataIn = 8'hFF;

module bus_conn (
    output logic [7:0] dataout,
    input        [7:0] datain = My_DataIn);

    assign dataout = datain;
endmodule

module bus_connect1 (
    output logic [31:0] dataout,
    input        [ 7:0] datain);

    parameter logic [7:0] My_DataIn = 8'h00;

    bus_conn bconn0 (dataout[31:24], 8'h0F);
        // Constant literal overrides default in bus_conn definition

    bus_conn bconn1 (dataout[23:16]);
        // Omitted port for datain, default parameter value 8'hFF in
        // bus_conn used

    bus_conn bconn2 (dataout[15:8], My_DataIn);
        // The parameter value 8'h00 from the instantiating scope is used

```

```
    bus_conn bconn3 (dataout[7:0]);  
endmodule
```

23.2.3 Parameterized modules

Port declarations can be based on parameter declarations. Parameter types can be re-defined for each instance of a module, providing a means of customizing the characteristics of each instance of a module.

Example 1—Parameterized module declaration using non-ANSI style module header:

```
module generic_fifo (clk, read, write, reset, out, full, empty );  
    parameter MSB=3, LSB=0, DEPTH=4; // these parameters can be redefined  
    input  [MSB:LSB] in;  
    input  clk, read, write, reset;  
    output [MSB:LSB] out;  
    output full, empty;  
    wire  [MSB:LSB] in;  
    wire  clk, read, write, reset;  
    logic [MSB:LSB] out;  
    logic full, empty;  
    ...  
endmodule
```

Example 2—Parameterized module declaration using ANSI style module header:

```
module generic_fifo  
    #(parameter MSB=3, LSB=0, DEPTH=4) // these parameters can be redefined  
    (input wire  [MSB:LSB] in,  
     input wire  clk, read, write, reset,  
     output logic [MSB:LSB] out,  
     output logic full, empty );  
    ...  
endmodule
```

Parameter redefinition is discussed in [23.10](#).

The order used in defining the list of parameters can be significant when instantiating the module (see [23.10.2.1](#)).

Example 3—Parameterized module header with local parameters using ANSI style header:

```
module generic_decoder  
    #(num_code_bits = 3, localparam num_out_bits = 1 << num_code_bits)  
    (input [num_code_bits-1:0] A, output reg [num_out_bits-1:0] Y);
```

23.2.4 Module contents

The module definition can contain zero or more module items. The syntax is shown in [Syntax 23-5](#).

```
module_common_item ::=                                     //from A.1.4  
    module_or_generate_item_declaration  
    | interface_instantiation  
    | program_instantiation
```

```

| assertion_item
| bind_directive
| continuous_assign
| net_alias
| initial_construct
| final_construct
| always_construct
| loop_generate_construct
| conditional_generate_construct
module_item ::=
    port_declaration ;
    | non_port_module_item
module_or_generate_item ::=
    { attribute_instance } parameter_override
    | { attribute_instance } gate_instantiation
    | { attribute_instance } udp_instantiation
    | { attribute_instance } module_instantiation
    | { attribute_instance } module_common_item
module_or_generate_item_declaration ::=
    package_or_generate_item_declaration
    | genvar_declaration
    | clocking_declaration
    | default clocking clocking_identifier ;
non_port_module_item ::=
    generate_region
    | module_or_generate_item
    | specify_block
    | { attribute_instance } specparam_declaration
    | program_declaration
    | module_declaration
    | interface_declaration
    | timeunits_declaration3
parameter_override ::= defparam list_of_defparam_assignments ;
bind_directive4 ::=
    bind bind_target_scope [ : bind_target_instance_list ] bind_instantiation ;
    | bind bind_target_instance bind_instantiation ;
bind_target_scope ::=
    module_identifier
    | interface_identifier
bind_target_instance ::=
    hierarchical_identifier constant_bit_select
bind_target_instance_list ::=
    bind_target_instance { , bind_target_instance }
bind_instantiation ::=
    program_instantiation
    | module_instantiation
    | interface_instantiation
    | checker_instantiation

```

- 3) A `timeunits_declaration` shall be legal as a `non_port_module_item`, `non_port_interface_item`, `non_port_program_item`, or `package_item` only if it repeats and matches a previous `timeunits_declaration` within the same time scope.
- 4) If the `bind_target_scope` is an `interface_identifier` or the `bind_target_instance` is an `interface_instance_identifier`, then the `bind_instantiation` shall be an `interface_instantiation`.

Syntax 23-5—Module item syntax (excerpt from [Annex A](#))

The module items define what constitutes a module, and can include many different types of declarations and definitions, which are described in various clauses throughout this document.

23.3 Module instances (hierarchy)

A module can be instantiated in two ways, hierarchical or top level. Top-level modules are implicitly instantiated (see [23.3.1](#)). Hierarchical modules can be instantiated explicitly (see [23.3.2](#)), or implicitly as a nested module (see [23.4](#)).

23.3.1 Top-level modules and `$root`

Top-level modules are modules that are included in the SystemVerilog source text, but do not appear in any module instantiation statement, as described in [23.3.2](#). This applies even if the module instantiation appears in a generate block that is not itself instantiated (see [27.3](#)). A design shall contain at least one top-level module. A top-level module is implicitly instantiated once, and its instance name is the same as the module name. Such an instance is called a *top-level instance*.

The name `$root` is used to unambiguously refer to a top-level instance or to an instance path starting from the root of the instantiation tree. `$root` is the root of the instantiation tree.

For example:

```
$root.A.B      // item B within top instance A
$root.A.B.C    // item C within instance B within instance A
```

`$root` allows explicit access to the top of the instantiation tree. This is useful to disambiguate a local path (which takes precedence) from the rooted path. If `$root` is not specified, a hierarchical path is ambiguous. For example, `A.B.C` can mean the local `A.B.C` or the top-level `A.B.C` (assuming there is an instance `A` that contains an instance `B` at both the top level and in the current module). The ambiguity is resolved by giving priority to the local scope and thereby preventing access to the top-level path. `$root` allows explicit access to the top level in those cases in which the name of the top-level module is insufficient to uniquely identify the path.

23.3.2 Module instantiation syntax

Explicit module instantiation creates a *hierarchical instance* of a module. The syntax for explicit module instantiation is as follows in [Syntax 23-6](#).

```
module_instantiation ::= // from A.4.1.1
    module_identifier [ parameter_value_assignment ] hierarchical_instance { , hierarchical_instance };
parameter_value_assignment ::= # ( [ list_of_parameter_assignments ] )
list_of_parameter_assignments ::=
    ordered_parameter_assignment { , ordered_parameter_assignment }
    | named_parameter_assignment { , named_parameter_assignment }
```

```

ordered_parameter_assignment ::= param_expression
named_parameter_assignment ::= . parameter_identifier ( [ param_expression ] )
hierarchical_instance ::= name_of_instance ( [ list_of_port_connections ] )
name_of_instance ::= instance_identifier { unpacked_dimension }
list_of_port_connections25 ::=
    ordered_port_connection { , ordered_port_connection }
    | named_port_connection { , named_port_connection }
ordered_port_connection ::= { attribute_instance } [ expression ]
named_port_connection ::=
    { attribute_instance } . port_identifier [ ( [ expression ] ) ]
    | { attribute_instance } .*
param_expression ::= mintypmax_expression | data_type

```

//from [A.8.3](#)

25) The `.*` token shall appear at most once in a list of port connections.

Syntax 23-6—Module instance syntax (excerpt from [Annex A](#))

Hierarchical instantiation allows more than one instance of the same module. The module name can be a module previously declared or one declared later. Parameter assignments can be named or ordered. Port connections can be named, ordered, or implicitly connected. They can be nets, variables, or other kinds of interfaces, events, or expressions. See [23.3.3](#) for the connection rules.

The instantiations of modules can contain a range specification. This allows an array of instances to be created. The array of instances is described in [28.3.5](#) (also see [23.3.3.5](#)). The syntax and semantics of arrays of instances defined for gates and primitives apply for modules as well.

The list of port connections shall be provided only for modules defined with ports. The parentheses shall be required on all module instantiations, even when the instantiated module does not have ports.

One or more module instances (identical copies of a module) can be specified in a single module instantiation statement. For example, three instances of a module called `ffnand` can be instantiated as:

```

ffnand ff1 (.q(), .qbar(out1), .clear(in1), .preset(in2)),
          ff2 (.q(), .qbar(out2), .clear(in2), .preset(in1), .q());
          ff3 (.q(out3), .qbar(), .clear(in1), .preset(in2));

```

Connections can be made to module instances in the following four ways:

- Positional connections by port order (see [23.3.2.1](#))
- Named port connections using fully explicit connections (see [23.3.2.2](#))
- Named port connections using implicit connections (see [23.3.2.3](#))
- Named port connections using a wildcard port name (see [23.3.2.4](#))

Positional and named module port connections shall not be mixed in the same module instantiation; connections to the ports of a particular module instance shall be all by order or all by name. The three forms of named port connections can be mixed.

An ALU accumulator (`alu_accum`) example module is used to illustrate these four forms of port connections. The ALU accumulator includes instantiations of an ALU module, an accumulator register (`accum`) module, and a sign-extension (`xtend`) module. The module headers for the three instantiated modules are shown in the following example code:

```

parameter logic [7:0] My_DataIn = 8'hFF;

module alu (
    output reg [7:0] alu_out,
    output reg zero,
    input [7:0] ain, bin,
    input [2:0] opcode);
    // RTL code for the alu module
endmodule

module accum (
    output reg [7:0] dataout,
    input [7:0] datain = My_DataIn,
    input clk, rst_n = 1'b1);
    // RTL code for the accumulator module
endmodule

module xtend (
    output reg [7:0] dout,
    input din,
    input clk, rst = 1'b0 );
    // RTL code for the sign-extension module
endmodule

```

23.3.2.1 Connecting module instance ports by ordered list

One method of making the connection between the port expressions listed in a module instantiation and the ports declared within the instantiated module is the ordered list; that is, the port expressions listed for the module instance shall be in the same order as the ports listed in the module declaration.

A connection can be a simple reference to a variable or a net identifier, an expression, or a blank. An expression can be used for supplying a value to a module input port. A blank port connection shall represent the situation where the port is not to be connected. However, if a port connection is omitted (indicated by a missing argument in the comma-separated list) to an input port with a default value, the default value shall be used.

Examples of module instantiations with positional port connections and default values are shown in the `alu_accum1` module example below.

```

module alu_accum1 (
    output [15:0] dataout,
    input [7:0] ain, bin,
    input [2:0] opcode,
    input clk, rst_n, rst);
    wire [7:0] alu_out;

    alu alu (alu_out, , ain, bin, opcode); // zero output is unconnected

    accum accum (dataout[7:0], alu_out, clk, rst_n);
    xtend xtend (dataout[15:8], alu_out[7], clk); // rst gets default
                                                // value 1'b0

endmodule

```

Refer to [23.3.3](#) for additional port connection rules.

23.3.2.2 Connecting module instance ports by name

The second way to connect module ports consists of explicitly linking the two names for each side of the connection: the port declaration name from the module declaration to the expression, i.e., the name used in the module declaration, followed by the name used in the instantiating module. This compound name is then placed in the list of module connections. The informal syntax for named port connections of a module with two ports is as follows:

```
module_name instance_name ( .port_name(expression), .port_name(expression) );
```

The *port name* shall be the name specified in the module declaration. The port name cannot be a bit-select, a part-select, or a concatenation of ports.

The port *expression* can be any valid expression. The port *expression* is optional so that the instantiating module can document the existence of the port without connecting it to anything. The parentheses are required.

If an input port with a specified default value has an explicit empty named port connection (i.e., `.port_name()`), then the port shall be left unconnected and the default value shall not be used. When connecting ports by name, an unconnected port can also be indicated by omitting it in the port list providing there is no default value.

Examples of module instantiations with named port connections and default values are shown in the `alu_accum2` module example below.

```
module alu_accum2 (
    output [15:0] dataout,
    input [7:0] ain, bin,
    input [2:0] opcode,
    input clk, rst_n, rst);
    wire [7:0] alu_out;

    alu alu (.alu_out(alu_out), .zero(),
            .ain(ain), .bin(bin), .opcode(opcode));
    // zero output is unconnected

    accum accum (.dataout(dataout[7:0]), .datain(alu_out),
                .clk(clk));
    // rst_n is not in the port list and so gets default value 1'b1

    xtend xtend (.dout(dataout[15:8]), .din(alu_out[7]),
                .clk(clk), .rst() );
    // rst has a default value, but has an empty port connection,
    // therefore it is left unconnected
endmodule
```

Because the connections in the example above are made by name, the order in which they appear is irrelevant.

Multiple module instance port connections are not allowed. The following example instantiation is illegal:

```
module test;
    A ia ( .i (a), .i (b), // illegal connection of input port twice
          .o (c), .o (d), // illegal connection of output port twice
          .e (e), .e (f)); // illegal connection of inout port twice
endmodule
```

```
module A (input i, output o, inout e);  
    ...  
endmodule
```

Refer to [23.3.3](#) for additional port connection rules.

23.3.2.3 Connecting module instance using implicit named port connections (.name)

SystemVerilog can implicitly instantiate ports using a *.name* syntax if the instance port name matches the connecting port name and their data types are equivalent.

This eliminates the requirement to list an identifier name twice when the port name and expression name are the same, while still listing all of the ports of the instantiated module for documentation purposes.

If a signal of the same name does not exist in the instantiating module, the port connection shall not create an implicit net declaration and an error shall be issued, even if the port has a specified default value. The purpose of using default values is to implicitly assign constant expressions to otherwise unconnected input ports. If an implicit *.name* port connection is used, it is assumed that the coder's intent is to connect this port value and not use the default value. To leave a port with a default value unconnected, empty parentheses must be used after *.name*, i.e., *.name()*.

In the following `alu_accum3` example, all of the ports of the instantiated `alu` module match the names of the declarations connected to the ports, except for the unconnected `zero` port, which is listed using a named port connection, showing that the port is unconnected. Implicit *.name* port connections are made for all name and equivalent type matching connections on the instantiated module.

In the same `alu_accum3` example, the `accum` module has an 8-bit port called `dataout` that is connected to a 16-bit bus called `dataout`. Because the internal and external sizes of `dataout` do not match, the port must be connected by name, showing which bits of the 16-bit bus are connected to the 8-bit port. The `datain` port on the `accum` is connected to a bus by a different name (`alu_out`); therefore, this port is also connected by name. `clk` is connected using an implicit *.name* port connection while the `rst_n` port is left unconnected because it uses empty parentheses. Also in the same `alu_accum3` example, the `xtend` module has an 8-bit output port called `dout` and a 1-bit input port called `din`. Because neither of these port names matches the names (or sizes) of the connecting declarations, both are connected by name. `clk` is connected using an implicit *.name* port connection, but the `rst` signal does not exist in the instantiation module and hence will result in an error even though a default port value exists.

```
module alu_accum3 (  
    output [15:0] dataout,  
    input [7:0] ain, bin,  
    input [2:0] opcode,  
    input clk, rst_n);  
    wire [7:0] alu_out;  
  
    alu alu (.alu_out, .zero(), .ain, .bin, .opcode);  
    accum accum (.dataout(dataout[7:0]), .datain(alu_out), .clk, .rst_n());  
    xtend xtend (.dout(dataout[15:8]), .din(alu_out[7]), .clk, .rst);  
    // Error: rst does not exist in the instantiation module  
endmodule
```

A *.port_identifier* port connection is semantically equivalent to the named port connection *.port_identifier(port_identifier)* with the following exceptions:

- The port connection shall not create an implicit net declaration.
- The declarations on each side of the port connection shall have equivalent data types.

- An implicit *.port_identifier* port connection between nets of two dissimilar net types shall issue an error when it is a warning in an explicit named port connection as required by [23.3.3.7](#).

It shall be an error if the name `port_identifier` has not been declared (explicitly or implicitly) or imported from a package (by explicit or wildcard import) prior to the *.port_identifier* implicit port connection.

23.3.2.4 Connecting module instances using wildcard named port connections (*.**)

SystemVerilog can implicitly instantiate ports using a *.** wildcard syntax for all ports where the instance port name matches the connecting port name and their data types are equivalent. This eliminates the requirement to list any port where the name and type of the connecting declaration match the name and equivalent type of the instance port. This implicit port connection style is used to indicate that all port names and types match the connections where emphasis is placed only on the exception ports. A named port connection can be mixed with a *.** connection to override a port connection to a different expression or to leave a port unconnected. The implicit *.** port connection syntax can greatly facilitate rapid block-level testbench generation where all of the testbench declarations are chosen to match the instantiated module port names and types.

An implicit *.** port connection is semantically equivalent to an implicit *.name* port connection for every port declared in the instantiated module, with two exceptions:

- 1) If an instantiation uses a *.name* port connection, the default value to that port shall not be used. If the name does not exist in the instantiating scope, an error shall occur. When using *.**, however, the default value shall be used if the name does not exist in the instantiating scope. In this case, if an unconnected port is truly needed for a specific instantiation, then *.name()* can be used in addition to *.**.
- 2) Using *.** does not create a sufficient reference for a wildcard import of a name from a package. A named or implicit *.name* connection can be mixed with a *.** connection to create a sufficient reference for a wildcard import of a name from a package.

In the following `alu_accum4` example, all of the ports of the instantiated `alu` module match the names of the variables connected to the ports, except for the unconnected `zero` port, which is listed using a named port connection, showing that the port is unconnected. The implicit *.** port connection syntax connects all other ports on the instantiated module.

In the same `alu_accum4` example, the `accum` module has an 8-bit port called `dataout` that is connected to a 16-bit bus called `dataout`. Because the internal and external sizes of `dataout` do not match, the port must be connected by name, showing which bits of the 16-bit bus are connected to the 8-bit port. The `datain` port on the `accum` is connected to a bus by a different name (`alu_out`); therefore, this port is also connected by name. The `clk` port is connected using an implicit *.** port connection while `rst_n` does not exist at the instantiation level, and therefore the default `rst_n` value is used. Also in the same `alu_accum4` example, the `xtend` module has an 8-bit output port called `dout` and a 1-bit input port called `din`. Because neither of these port names matches the names (or sizes) of the connecting declarations, both are connected by name. The `clk` port is connected using an implicit *.** port connection while again `rst` does not exist at the instantiation level, and therefore the default `rst` value is used.

```

module alu_accum4 (
    output [15:0] dataout,
    input [7:0] ain, bin,
    input [2:0] opcode,
    input clk);
    wire [7:0] alu_out;

    alu alu (.*, .zero());

```

```
    accum accum (*, .dataout(dataout[7:0]), .datain(alu_out));  
    xtend xtend (*, .dout(dataout[15:8]), .din(alu_out[7]));  
endmodule
```

When the implicit `.*` port connection is mixed in the same instantiation with named port connections, the implicit `.*` port connection token can be placed anywhere in the port list. The `.*` token can only appear at most once in the port list.

Modules can be instantiated into the same parent module using any combination of legal positional, named, implicit `.name` connected and implicit `.*` connected instances, as shown in `alu_accum5` example below.

```
module alu_accum5 (  
    output [15:0] dataout,  
    input [7:0] ain, bin,  
    input [2:0] opcode,  
    input clk, rst_n;  
    wire [7:0] alu_out;  
  
    // mixture of named port connections and  
    // implicit .name port connections  
    alu alu (.ain(ain), .bin(bin), .alu_out, .zero(), .opcode);  
  
    // positional port connections  
    accum accum (dataout[7:0], alu_out, clk, rst_n);  
  
    // mixture of named port connections and implicit .* port connections  
    xtend xtend (.dout(dataout[15:8]), .*, .din(alu_out[7]));  
endmodule
```

23.3.3 Port connection rules

Values of all data types on variables and nets can be passed through ports. This is accomplished by allowing both sides of a port connection to have assignment-compatible data types and by allowing continuous assignments to variables. The **ref** port type allows shared variable behavior across a port by passing a hierarchical reference.

Each port connection shall be a continuous assignment of source to sink, where one connected item shall be a signal source and the other shall be a signal sink. The assignment shall be a continuous assignment from source to sink for input or output ports. The assignment is a non-strength-reducing transistor connection for inout ports.

The same rules are used for compatible port types as for assignment compatibility (see [6.22.3](#)).

23.3.3.1 Port coercion

A port that is declared as input (output) but used as an output (input) or inout may be coerced to inout. If not coerced to inout, a warning shall be issued.

23.3.3.2 Port connection rules for variables

If a port declaration has a variable data type, then its direction controls how it can be connected when instantiated, as follows:

- An **input** port can be connected to any expression of a compatible data type. A continuous assignment shall be implied when a variable is connected to an input port declaration. Assignments

to variables declared as input ports shall be illegal. If left unconnected, the port shall have the default initial value corresponding to the data type.

- An **output** port can be connected to a variable (or a concatenation) of a compatible data type. A continuous assignment shall be implied when a variable is connected to the output port of an instance. Procedural or continuous assignments to a variable connected to the output port of an instance shall be illegal.
- An **output** port can be connected to a net (or a concatenation) of a compatible data type. In this case, multiple drivers shall be permitted on the net.
- A variable data type is not permitted on either side of an **inout** port.
- A **ref** port shall be connected to an equivalent variable data type. References to the port variable shall be treated as hierarchical references to the variable to which it is connected in its instantiation. This kind of port cannot be left unconnected. See [6.22.2](#).

23.3.3.3 Port connection rules for nets

If a port declaration has a net type, such as **wire**, then its direction controls how it can be connected, as follows:

- An **input** can be connected to any expression of a compatible data type. If left unconnected, it shall have the value 'z'.
- An **output** can be connected to a net or variable (or a concatenation of nets or variables) of a compatible data type.
- An **inout** can be connected to a net (or a concatenation of nets) of a compatible data type or left unconnected, but cannot be connected to a variable.

If there is a data type difference between the port declaration and connection, an initial value change event can be caused at time zero.

See [23.3.3.7](#) for additional rules when net types are used on both sides of a port connection.

23.3.3.4 Port connection rules for interfaces

A port declaration can be a generic interface or named interface type. An interface port instance shall always be connected to an interface instance or a higher level interface port. An interface port cannot be left unconnected.

If a port declaration has a generic interface type, then it can be connected to an interface instance of any type. If a port declaration has a named interface type, then it shall be connected to an interface instance of the identical type.

23.3.3.5 Unpacked array ports and arrays of instances

For an unpacked array port, the port and the array connected to the port shall have the same number of unpacked dimensions, and each dimension of the port shall have the same size as the corresponding dimension of the array being connected.

If the size and type of the port connection match the size and type of a single instance port, the connection shall be made to each instance in an array of instances.

If the port connection is an unpacked array, the slowest varying unpacked array dimensions of each port connection shall be compared with the dimensions of the instance array. If they match exactly in size, each element of the port connection shall be matched to the port left index to left index, right index to right index. If they do not match it shall be considered an error.

For example:

```
module child(output o, input i[5]);
    //...
endmodule : child

module parent(output o[8][4],
              input i[8][4][5] );
    child c[8][4](o,i);
    //...
endmodule : parent
```

If the port connection is a packed array, each instance shall get a part-select of the port connection, starting with all right-hand indices to match the rightmost part-select and iterating through the rightmost dimension first. Too many or too few bits to connect all the instances shall be considered an error.

In the example below, a two-dimensional array of DFF instances is connected to form M pipelines with N stages.

```
module MxN_pipeline #(M=3,N=4)
    (input [M-1:0] in, output [M-1:0] out, input clk);

    typedef logic T [M-1:0][1:N];
    T Ins, Outs;

    DFF dff[M-1:0][1:N](Outs, Ins, clk);

    for (genvar I = M-1; I >= 0; I--) begin
        for (genvar J = 1; J <= N; J++) begin
            case (J)
                1: begin
                    assign out[I] = Outs[I][1];
                    assign Ins[I][J] = Outs[I][2];
                end
                default: assign Ins[I][J] = Outs[I][J+1];
                N: assign Ins[I][N] = in[I];
            endcase
        end
    end
endmodule : MxN_pipeline
```

23.3.3.6 Single source nets (uwire)

If the net on either side of a port has the net type `uwire`, a warning shall be issued if the nets are not merged into a single net, as described in [23.3.3.7](#).

23.3.3.7 Port connections with dissimilar net types (net and port collapsing)

When different net types are connected through a module port, the nets on both sides of the port can take on the same type. The resulting net type can be determined as shown in [Table 23-1](#). In the table, *external net* means the net specified in the module instantiation, and *internal net* means the net specified in the module definition. The net whose type is used is said to be the *dominating net*. The net whose type is changed is said to be the *dominated net*. It is permissible to merge the dominating and dominated nets into a single net, whose type shall be that of the dominating net. The resulting net is called the *simulated net*, and the dominated net is called a *collapsed net*.

The simulated net shall take the delay specified for the dominating net. If the dominating net is of the type **trireg**, any strength value specified for the **trireg** net shall apply to the simulated net.

Table 23-1—Net types resulting from dissimilar port connections

Internal net	External net								
	wire, tri	wand, triand	wor, trior	trireg	tri0	tri1	uwire	supply0	supply1
wire, tri	external	external	external	external	external	external	external	external	external
wand, triand	internal	external	external warn	external warn	external warn	external warn	external warn	external	external
wor, trior	internal	external warn	external	external warn	external warn	external warn	external warn	external	external
trireg	internal	external warn	external warn	external	external	external	external warn	external	external
tri0	internal	external warn	external warn	internal	external	external warn	external warn	external	external
tri1	internal	external warn	external warn	internal	external warn	external	external warn	external	external
uwire	internal	internal warn	internal warn	internal warn	internal warn	internal warn	external	external	external
supply0	internal	internal	internal	internal	internal	internal	internal	external	external warn
supply1	internal	internal	internal	internal	internal	internal	internal	external warn	external

KEY:
external = The external net type shall be used.
internal = The internal net type shall be used.
warn = A warning shall be issued.

When the two nets connected by a port are of different net types, the resulting single net can be assigned one of the following:

- The dominating net type if one of the two nets is dominating, or
- The net type external to the module

When a dominating net type does not exist, the external net type shall be used.

The simulated net shall take the net type specified in the table and the delay specified for that net. If the simulated net selected is a **trireg**, any strength value specified for the **trireg** net applies to the simulated net.

23.3.3.8 Connecting signed values via ports

The sign attribute shall not cross hierarchy. In order to have the signed type cross hierarchy, the **signed** keyword shall be used in the object's declaration at the different levels of hierarchy. Any expressions on a port shall be treated as any other expression in an assignment. It shall be typed, sized, and evaluated, and the resulting value assigned to the object on the other side of the port using the same rules as an assignment.

23.4 Nested modules

A module can be declared within another module. The outer name space is visible to the inner module so that any name declared there can be used, unless hidden by a local name, provided the module is declared and instantiated in the same scope.

One purpose of nesting modules is to show the logical partitioning of a module without using ports. Names that are global are in the outermost scope, and names that are only used locally can be limited to local modules.

```
// This example shows a D-type flip-flop made of NAND gates
module dff_flat(input d, ck, pr, clr, output q, nq);
wire q1, nq1, q2, nq2;

    nand g1b (nq1, d, clr, q1);
    nand g1a (q1, ck, nq2, nq1);

    nand g2b (nq2, ck, clr, q2);
    nand g2a (q2, nq1, pr, nq2);

    nand g3a (q, nq2, clr, nq);
    nand g3b (nq, q1, pr, q);
endmodule

// This example shows how the flip-flop can be structured into 3 RS latches.
module dff_nested(input d, ck, pr, clr, output q, nq);
wire q1, nq1, nq2;

    module ff1;
        nand g1b (nq1, d, clr, q1);
        nand g1a (q1, ck, nq2, nq1);
    endmodule
    ff1 i1();

    module ff2;
        wire q2; // This wire can be encapsulated in ff2
        nand g2b (nq2, ck, clr, q2);
        nand g2a (q2, nq1, pr, nq2);
    endmodule
    ff2 i2();

    module ff3;
        nand g3a (q, nq2, clr, nq);
        nand g3b (nq, q1, pr, q);
    endmodule
    ff3 i3();
endmodule
```

The nested module declarations can also be used to create a library of modules that is local to part of a design.

```
module part1(...);
    module and2(input a, b, output z);
    ....
endmodule
module or2(input a, b, output z);
```

```

    ....
    endmodule
    ....
    and2 u1(....), u2(....), u3(....);
    ....
endmodule

```

This allows the same module name, e.g., `and2`, to occur in different parts of the design and represent different modules. An alternative way of handling this problem is to use configurations.

Nested modules with no ports that are not explicitly instantiated shall be implicitly instantiated once with an instance name identical to the module name. Otherwise, if they have ports and are not explicitly instantiated, they are ignored.

23.5 Extern modules

To support separate compilation, extern declarations of a module can be used to declare the ports on a module without defining the module itself. An extern module declaration consists of the keyword **extern** followed by the module name and the list of ports for the module. Both the ANSI style *list_of_port_declarations* syntax (possibly with parameters) and the non-ANSI style *list_of_ports* syntax may be used.

NOTE—The potential existence of defparams precludes the checking of the port connection information prior to elaboration time even for the ANSI style *list_of_port_declarations* syntax.

The following example demonstrates the usage of extern module declarations:

```

extern module m (a,b,c,d);
extern module a #(parameter size= 8, parameter type TP = logic [7:0])
    (input [size:0] a, output TP b);

module top ();
    wire [8:0] a;
    logic [7:0] b;
    wire      c, d;

    m mm (.*);
    a aa (.*);
endmodule

```

Modules `m` and `a` are then assumed to be instantiated as follows:

```

module top ();
    wire [8:0] a;
    logic [7:0] b;
    wire      c, d;

    m mm (a,b,c,d);
    a aa (a,b);
endmodule

```

If an **extern** declaration exists for a module, it is possible to use `.*` as the ports of the module. This usage shall be equivalent to placing the ports (and possibly parameters) of the **extern** declaration on the module.

For example:

```

extern module m (a,b,c,d);
extern module a #(parameter size = 8, parameter type TP = logic [7:0])
    (input [size:0] a, output TP b);

module m (.*);
    input a,b,c;
    output d;
endmodule

module a (.*);
    ...
endmodule
  
```

is equivalent to writing

```

module m (a,b,c,d);
    input a,b,c;
    output d;
endmodule

module a #(parameter size = 8, parameter type TP = logic [7:0])
    (input [size:0] a, output TP b);
    ...
endmodule
  
```

Extern module declarations can appear at any level of the instantiation hierarchy, but are visible only within the level of hierarchy in which they are declared. An extern module declaration shall match the actual module declaration's port and parameter lists in correspondence of names, positions, and their equivalent types.

23.6 Hierarchical names

Every identifier in a SystemVerilog description shall have a unique *hierarchical path name*. The hierarchy of modules and the definition of items such as tasks and named blocks within the modules shall define these names. The hierarchy of names can be viewed as a tree structure, where each module instance, generate block instance, task, function, or named begin-end or fork-join block defines a new hierarchical level, or *scope*, in a particular branch of the tree.

A design description contains one or more top-level modules (see [23.3.1](#)). Each such module forms the top of a name hierarchy. This root or these parallel root modules make up one or more hierarchies in a *design description* or *description*. Inside any module, each module instance (including an arrayed instance), generate block instance, task definition, function definition, and named begin-end or fork-join block shall define a new branch of the hierarchy. Named blocks within named blocks and within tasks and functions shall create new branches. Unnamed generate blocks are exceptions. They create branches that are visible only from within the block and within any hierarchy instantiated by the block. See [Clause 27](#) for a discussion of unnamed generate blocks.

Each node in the hierarchical name tree shall be a separate scope with respect to identifiers. A particular identifier can be declared at most once in any scope. See [23.9](#) for a discussion of scope rules and [3.13](#) for a discussion of name spaces.

Any named SystemVerilog object or *hierarchical name reference* can be referenced uniquely in its full form by concatenating the names of the modules, module instance names, generate blocks, tasks, functions, or named blocks that contain it. The period character shall be used to separate each of the names in the

hierarchy, except for escaped identifiers embedded in the hierarchical name reference, which are followed by separators composed of white space and a period-character.

The syntax for hierarchical path names is given in [Syntax 23-7](#).

```
hierarchical_identifier ::= [ $root . ] { identifier constant_bit_select . } identifier //from A.9.3
```

Syntax 23-7—Syntax for hierarchical path names (excerpt from [Annex A](#))

Hierarchical names consist of instance names separated by periods, where an instance name can be an array element. The instance name `$root` refers to the top of the instantiated design and is used to unambiguously gain access to the top of the design.

```
$root.mymodule.u1 // absolute name
u1.struct1.field1 // u1 must be visible locally or above, including globally
adder1[5].sum
```

The complete path name to any object shall start at a top-level (root) module. This path name can be used from any level in the hierarchy or from a parallel hierarchy.

The first node name in a path name can also be the top of a hierarchy that starts at the level where the path is being used (which allows and enables downward referencing of items).

Objects declared in automatic tasks and functions are exceptions and cannot be accessed by hierarchical name references. Objects declared in unnamed generate blocks are also exceptions. They can be referenced by hierarchical names only from within the block and within any hierarchy instantiated by the block.

Names in a hierarchical path name that refer to instance arrays or loop generate blocks may be followed immediately by a constant expression in square brackets. This expression selects a particular instance of the array and is, therefore, called an *instance select*. The expression shall evaluate to one of the legal index values of the array. If the array name is not the last path element in the hierarchical name, the instance select expression is required.

Hierarchical name referencing allows free data access to any object from any level in the hierarchy. If the unique hierarchical path name of an item is known, its value can be sampled or changed from anywhere within the description.

Hierarchical names can be read (in expressions), written (in assignments or in subroutine calls) or triggered off (in event expressions). They can also be used to reference subroutine names.

Example 1—The code in this example defines a hierarchy of module instances and named blocks.

```
module cct (stim1, stim2);
  input stim1, stim2;
  // instantiate mod
  mod amod(stim1),
    bmod(stim2);
endmodule

module mod (in);
  input in;

  always @(posedge in) begin : keep
    logic hold;
```

```

        hold = in;
    end
endmodule

module wave;
    logic stim1, stim2;

    cct a(stim1, stim2); // instantiate cct

    initial begin :wave1
        #100    fork :innerwave
                reg hold;
            join
        #150    begin
                stim1 = 0;
            end
    end
end
endmodule

```

Figure 23-1 illustrates the hierarchy implicit in this code.

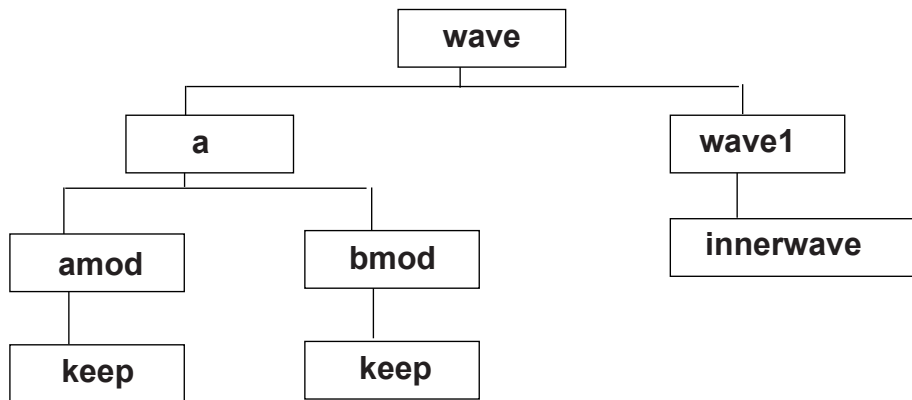

Figure 23-1—Hierarchy in a model

Following is a list of the hierarchical forms of the names of all the objects defined in the code.

```

wave
wave.stim1
wave.stim2
wave.a
wave.a.stim1
wave.a.stim2
wave.a.amod
wave.a.amod.in
wave.a.amod.keep
wave.a.amod.keep.hold
wave.a.bmod
wave.a.bmod.in
wave.a.bmod.keep
wave.a.bmod.keep.hold
wave.wave1
wave.wave1.innerwave
wave.wave1.innerwave.hold

```

Any of the hierarchical names above can also be preceded with \$root.

Example 2—The following example shows how a pair of named blocks can refer to items declared within each other.

```

begin
  fork : mod_1
    reg x;
    mod_2.x = 1;
  join
  fork : mod_2
    reg x;
    mod_1.x = 0;
  join
end

```

Hierarchical references into checkers (see [Clause 17](#)) shall not be permitted.

23.7 Member selects and hierarchical names

A hierarchical name and a member select into a structure, union, class or covergroup object share the same syntactic form of a sequence of name components separated by periods. Such names are called *dotted names* prior to the determination of whether the name is a hierarchical name or member select. The distinguishing aspect of a hierarchical name is that the first component of the name must match a scope name while the first name component of a member select must match a variable name. The general approach used is to attempt to resolve the first name component immediately and to use the results of that resolution attempt to determine how to treat the overall name.

When a dotted name is encountered at its point of appearance, the first name in the sequence is resolved as though it were a simple identifier. The following are the possible results:

- The name resolves to a variable or member declaration. The dotted name shall be considered to be a member select of that variable or member.
- The name resolves to a directly visible scope name. The dotted name shall be considered to be a hierarchical name.
- The name resolves to an imported scope name. The dotted name shall be resolved in the same manner as a hierarchical name prefixed by the package name from which the name was imported.
- The name is not found. The dotted name shall be considered to be a hierarchical name.

It is important to note that resolution to an imported scope name is different than resolution to a directly visible scope name (see [23.7.1](#)).

Example:

```

package p;
  struct { int x; } s1;
  struct { int x; } s2;
  function void f();
    int x;
  endfunction
endpackage

module m;
  import p::*;
  if (1) begin : s1
    initial begin
      s1.x = 1; // dotted name 1
    end
  end
endmodule

```



```

    s2.x = 1;    // dotted name 2
    f.x = 1;    // dotted name 3
    f2.x = 1;   // dotted name 4
  end
  int x;
  some_module s2();
end
endmodule

```

The following describes the resolution of each of the dotted names:

- Dotted name 1: The first name component is `s1`. Since `s1` is a directly visible scope name, rule b) applies and the name `s1.x` is considered to be a hierarchical name.
- Dotted name 2: The first name component is `s2`. Since at the time of analysis the module instantiation scope `s2` (from `some_module s2();`) is not yet visible, the name `s2` binds to the visible name `s2` from package `p` and rule a) applies. This causes `s2` to be imported into module `m` as would occur with a normal variable reference.
- Dotted name 3: The first name component is `f`. Since `f` is an imported scope name, rule c) applies and the name `f.x` is considered to be a hierarchical name equivalent to `p:f.x`.
- Dotted name 4: The first name component is `f2`. Since `f2` has no visible definition, rule d) applies and the name `f2.x` is considered to be a hierarchical name.

23.7.1 Names with package or class scope resolution operator prefixes

A name with a package or class scope resolution prefix (`::`) shall always resolve in a downwards manner and shall never be subject to the upwards resolution rules in [23.8](#). If the prefix name can be resolved using the normal scope resolution rules, the `::` shall denote the class resolution operator. Otherwise the `::` shall denote the package resolution operator.

23.8 Upwards name referencing

The name of a module or module instance is sufficient to identify the module and its location in the hierarchy. A lower level module can reference items in a module above it in the hierarchy. Variables can be referenced if the name of the higher level module or its instance name is known. For tasks, functions, named blocks, and generate blocks, SystemVerilog shall look in the enclosing module for the name until it is found or until the root of the hierarchy is reached. It shall only search in higher enclosing modules for the name, not instances.

The syntax for an upward reference is given in [Syntax 23-8](#).

```

upward_name_reference ::=
    module_identifier . item_name
item_name ::=
    function_identifier
    | block_identifier
    | net_identifier
    | parameter_identifier
    | port_identifier
    | task_identifier
    | variable_identifier

```

Syntax 23-8—Syntax for upward name referencing (not in [Annex A](#))

Upward name references can also be done with names of the form

```
scope_name.item_name
```

where `scope_name` is either a subroutine name, a module, program, or interface instance name or a generate block name. A name of this form shall be resolved as follows:

- a) Look in the current scope for a scope named `scope_name`. If not found and the current scope is not the design element scope, look for the name in the enclosing scope, repeating as necessary until the name is found or the design element scope is reached. If still not found, proceed to step b). Otherwise, this name reference shall be treated as a downward reference from the scope in which the name is found.
- b) Look in the instantiation's parent scope for a scope named `scope_name`. If found, the item name shall be resolved in a downwards manner from that scope. If all name components of the item name are matched, the search terminates with the final matching item. If any component of the item name matches the name of a structure, union, class or covergroup object, no further upwards steps shall occur even if the item name does not find a match. Continue upwards through the enclosing scopes, repeating as necessary until the name is found or the design element scope is reached.
- c) Repeat step b), going up the hierarchy.

There is an exception to these rules for hierarchical names on the left-hand side of `defparam` statements. See [23.10.4](#) for details.

In the following example, there are four modules, `a`, `b`, `c`, and `d`. Each module contains an integer `i`. The highest level modules in this segment of a model hierarchy are `a` and `d`. There are two copies of module `b` because module `a` and `d` instantiate `b`. There are four copies of `c.i` because each of the two copies of `b` instantiates `c` twice.

```

module a;
  integer i;
  b a_b1();
endmodule

module b;
  integer i;
  c b_c1(),
    b_c2();
  initial
    #10 b_c1.i = 2;          // downward path references two copies of i:
                             // a.a_b1.b_c1.i, d.d_b1.b_c1.i
endmodule

module c;
  integer i;
  initial begin             // local name references four copies of i:
    i = 1;                  // a.a_b1.b_c1.i, a.a_b1.b_c2.i,
                             // d.d_b1.b_c1.i, d.d_b1.b_c2.i
    b.i = 1;                // upward path references two copies of i:
                             // a.a_b1.i, d.d_b1.i
  end
endmodule

module d;
  integer i;
  b d_b1();
  initial begin           // full path name references each copy of i
    a.i = 1;               d.i = 5;
    a.a_b1.i = 2;          d.d_b1.i = 6;
    a.a_b1.b_c1.i = 3;     d.d_b1.b_c1.i = 7;
  end

```

```
        a.a_b1.b_c2.i = 4;    d.d_b1.b_c2.i = 8;
    end
endmodule
```

23.8.1 Task and Function name resolution

Task and function names are resolved following slightly different rules than other references. Task and function name resolution follows the rules for upwards hierarchical name resolution as described in [23.8](#), step [a](#)). Then, before proceeding with step [b](#)), an implementation shall look in the complete compilation unit of the reference. If a task or function with a matching name is found there, the name resolves to that task or function. Only then does the resolution proceed with step [b](#)) and iterate as normal. The special matching within the compilation unit shall only take place the first time through the iteration through steps [a](#))–[c](#)); a task or function name shall never match a task or function in a compilation unit other than the compilation unit enclosing the reference.

Example 1:

```
task t;
    int x;
    x = f(1); // valid reference to function f in $unit scope
endtask

function int f(int y);
    return y+1;
endfunction
```

Example 2:

```
package p;
    function void f();
        $display("p::f");
    endfunction
endpackage

module top;
    import p::*;

    if (1) begin : b          // generate block
        initial f();        // reference to "f"
        function void f();
            $display("top.b.f");
        endfunction
    end
endmodule
```

The resolution of the name `f` follows the hierarchical rules and therefore is resolved to the function `top.b.f`. The output of the example would be the output of the string `"top.b.f"`.

23.9 Scope rules

The following elements define a new scope in SystemVerilog:

- Modules
- Interfaces
- Programs
- Checkers

- Packages
- Classes
- Tasks
- Functions
- begin-end blocks (named or unnamed)
- fork-join blocks (named or unnamed)
- Generate blocks

An identifier shall be used to declare only one item within a scope. This rule means it is illegal to declare two or more variables that have the same name, or to name a task the same as a variable within the same module, or to give a gate instance the same name as the name of the net connected to its output. For generate blocks, this rule applies regardless of whether the generate block is instantiated. An exception to this is made for generate blocks in a conditional generate construct. See [27.6](#) for a discussion of naming conditional generate blocks.

If an identifier is referenced directly (without a hierarchical path) within a task, function, named block, or generate block, it shall be declared either within the task, function, named block, or generate block locally or within a module, interface, program, checker, task, function, named block, or generate block that is higher in the same branch of the name tree that contains the task, function, named block, or generate block. If it is declared locally, then the local item shall be used; if not, the search shall continue upward until an item by that name is found or until a module, interface, program, or checker boundary is encountered. If the item is a variable, it shall stop at a module boundary; if the item is a task, function, named block, or generate block, it continues to search higher level modules until found. This fact means that tasks and functions can use and modify the variables within the containing module by name, without going through their formal arguments.

If an identifier is referenced with a hierarchical name, the path can start with a module name, interface name, program name, checker name, instance name, task, function, named block, or named generate block. The names shall be searched first at the current level and then in higher level modules until found. Because both module, interface, program, or checker names as well as instance names can be used, precedence is given to instance names if there is a module, interface, program, or checker named the same as an instance name.

Because of the upward searching, path names that are not strictly on a downward path can be used.

For example:

Example 1—In [Figure 23-1](#), each rectangle represents a local scope. The scope available to upward searching extends outward to all containing rectangles—with the boundary of the module A as the outer limit. Thus block G can directly reference identifiers in F, E, and A; it cannot directly reference identifiers in H, B, C, and D.

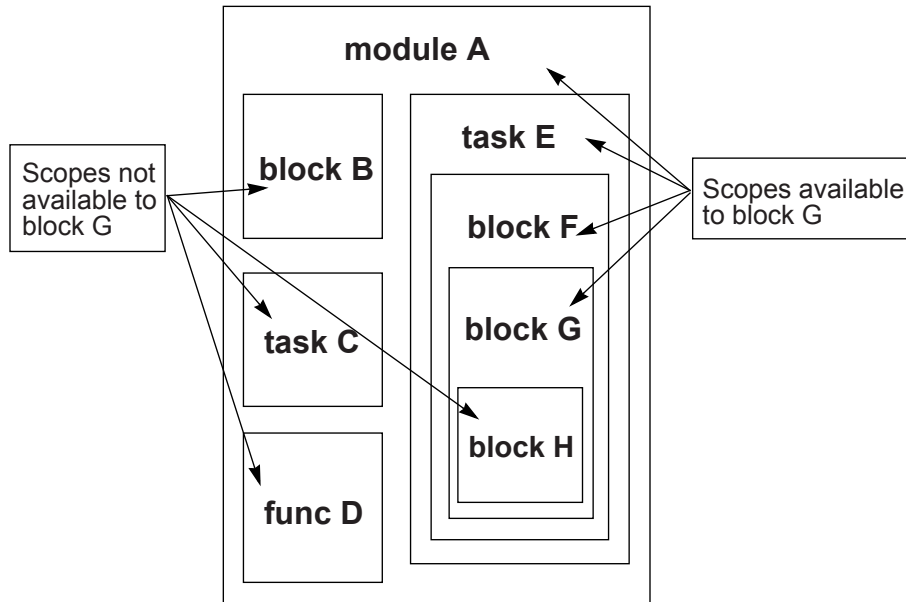

Figure 23-1—Scopes available to upward name referencing

Example 2—The following example shows how variables can be accessed directly or with hierarchical names:

```

task t;
  logic s;
  begin : b
    logic r;

    t.b.r = 0; // These three lines access the same variable r
    b.r = 0;
    r = 0;

    t.s = 0; // These two lines access the same variable s
    s = 0;
  end
endtask
    
```

23.10 Overriding module parameters

SystemVerilog provides two types of parameter constants which can be overridden, value parameters (see [6.20.2](#)), and type parameters (see [6.20.3](#)).

There are two different places parameters can be defined within a module (or interface or program). The first is the module's *parameter_port_list* (see [23.2](#)), and the second is as a *module_item* (see [6.20](#)). A module declaration can contain parameter definitions of either or both types or can contain no parameter definitions.

For example:

```

module generic_fifo
  # (MSB=3, LSB=0) // parameter port list parameters
  (input wire [MSB:LSB] in,
    
```

```

    input wire          clk, read, write, reset,
    output logic [MSB:LSB] out,
    output logic        full, empty );

parameter DEPTH=4;          // module item parameter

localparam FIFO_MSB = DEPTH*MSB;
localparam FIFO_LSB = LSB;
    // These constants are local, and cannot be overridden.
    // They can be affected by altering the value parameters above

logic [FIFO_MSB:FIFO_LSB] fifo;
logic [LOG2(DEPTH):0] depth;

always @(posedge clk or posedge reset) begin
    casez ({read,write,reset})
        // implementation of fifo
    endcase
end
endmodule

```

There are two ways to alter nonlocal parameters: the *defparam statement*, which allows assignment to parameters using their hierarchical names, and the *module instance parameter value assignment*, which allows values to be assigned in line during module instantiation. The module instance parameter value assignment comes in two forms, by ordered list or by name. The next two subclauses describe these two methods. If a **defparam** assignment conflicts with a module instance parameter, the parameter in the module will take the value specified by the **defparam**.

A value parameter (see [6.20.2](#)) can have a type specification and a range specification. The effect of parameter overrides on a value parameter's type and range shall be in accordance with the following rules:

- A value parameter declaration with no type or range specification shall default to the type and range of the final override value assigned to the parameter.
- A value parameter with a range specification, but with no type specification, shall have the range of the parameter declaration and shall be unsigned. An override value shall be converted to the type and range of the parameter.
- A value parameter with a type specification, but with no range specification, shall be of the type specified. An override value shall be converted to the type of the parameter. A signed parameter shall default to the range of the final override value assigned to the parameter.
- A value parameter with a signed type specification and with a range specification shall be signed and shall have the range of its declaration. An override value shall be converted to the type and range of the parameter.

For example:

```

module m1 (a,b);
    real r1,r2;
    parameter [2:0] A = 3'h2;
    parameter B = 3'h2;
    initial begin
        r1 = A;
        r2 = B;
        $display("r1 is %f r2 is %f",r1,r2);
    end
endmodule: m1

```

```
module m2;
  wire a,b;
  defparam f1.A = 3.1415;
  defparam f1.B = 3.1415;
  m1 f1(a,b);
endmodule: m2
```

Parameter **A** is a typed and/or ranged parameter; when its value is redefined, the parameter retains its original type and sign. Therefore, the **defparam** of `f1.A` with the value 3.1415 is performed by converting the floating point number 3.1415 into a fixed-point number 3, and then the low 3 bits of 3 are assigned to **A**.

Parameter **B** is not a typed and/or ranged parameter; when its value is redefined, the parameter type and range take on the type and range of the new value. Therefore, the **defparam** of `f1.B` with the value 3.1415 replaces **B**'s current value of 3'h2 with the floating point number 3.1415.

23.10.1 defparam statement

Using the *defparam statement*, parameter values can be changed in any module, interface, or program instance throughout the design using the hierarchical name of the parameter. See [23.6](#) for hierarchical names.

However, a **defparam** statement in a hierarchy in or under a generate block instance (see [Clause 27](#)) or an array of instances (see [28.3.5](#) and [23.3.2](#)) shall not change a parameter value outside that hierarchy.

Each instantiation of a generate block is considered to be a separate hierarchy scope. Therefore, a **defparam** statement in a generate block may not target a parameter in another instantiation of the same generate block, even when the other instantiation is created by the same loop generate construct. For example, the following code is not allowed:

```
genvar i;

generate
  for (i = 0; i < 8; i = i + 1) begin : somename
    flop my_flop(in[i], in1[i], out1[i]);
    defparam somename[i+1].my_flop.xyz = i ;
  end
endgenerate
```

Similarly, a **defparam** statement in one instance of an array of instances may not target a parameter in another instance of the array.

The expression on the right-hand side of **defparam** assignments shall be a constant expression involving only numbers and references to parameters. The referenced parameters (on the right-hand side of the **defparam**) shall be declared in the same module as the **defparam** statement.

The **defparam** statement is particularly useful for grouping all of the parameter value override assignments together in one module.

In the case of multiple **defparams** for a single parameter, the parameter takes the value of the last **defparam** statement encountered in the source text. When **defparams** are encountered in multiple source files, e.g., found by library searching, the **defparam** from which the parameter takes its value is undefined.

For example:

```
module top;
```

```

    logic      clk;
    logic [0:4] in1;
    logic [0:9] in2;
    wire [0:4] o1;
    wire [0:9] o2;

    vdff m1 (o1, in1, clk);
    vdff m2 (o2, in2, clk);
endmodule

module vdff (out, in, clk);
    parameter size = 1, delay = 1;
    input  [0:size-1] in;
    input          clk;
    output [0:size-1] out;
    logic  [0:size-1] out;

    always @(posedge clk)
        # delay out = in;
endmodule

module annotate;
    defparam
        top.m1.size = 5,
        top.m1.delay = 10,
        top.m2.size = 10,
        top.m2.delay = 20;
endmodule

```

The module `annotate` has the `defparam` statement, which overrides `size` and `delay` parameter values for instances `m1` and `m2` in the top-level module `top`. The modules `top` and `annotate` would both be considered top-level modules.

NOTE—The `defparam` statement might be removed from future versions of the language. See [C.4.1](#).

23.10.2 Module instance parameter value assignment

An alternative method for assigning values to parameters within module instances is to use one of the two forms of module instance parameter value assignment: *assignment by ordered list* and *assignment by name*. The two types of module instance parameter value assignment shall not be mixed; parameter assignments to a particular module instance shall be entirely by order or entirely by name.

Module instance parameter value assignment by ordered list is similar in appearance to the assignment of delay values to gate instances, and assignment by name is similar to connecting module ports by name. It supplies values for particular instances of a module to any parameters that have been specified in the definition of that module.

A parameter declared in a named block, task, or function can only be directly redefined using a `defparam` statement. However, if the parameter value is dependent on a second parameter, then redefining the second parameter will update the value of the first parameter as well (see [23.10.3](#)).

23.10.2.1 Parameter value assignment by ordered list

The order of the assignments in the module instance parameter assignment by ordered list shall follow the order of declaration of the parameters within the module. It is not necessary to assign values/types to all of the parameters within a module when using this method. However, it is not possible to skip over a parameter. Therefore, to assign values to a subset of the parameters declared within a module, the

declarations of the parameters that make up this subset shall precede the declarations of the remaining parameters. An alternative is to assign values to all of the parameters, but to use the default value (the same value assigned in the declaration of the parameter within the module definition) for those parameters that do not need new values.

Consider the following example, where the parameters within module instances `mod_a`, `mod_c`, and `mod_d` are changed during instantiation:

```

module tb1;
  wire [9:0] out_a, out_d;
  wire [4:0] out_b, out_c;
  logic [9:0] in_a, in_d;
  logic [4:0] in_b, in_c;
  logic      clk;

  // testbench clock & stimulus generation code ...

  // Four instances of vdff with parameter value assignment by ordered list

  // mod_a has new parameter values size=10 and delay=15
  // mod_b has default parameters (size=5, delay=1)
  // mod_c has one default size=5 and one new delay=12
  //   In order to change the value of delay,
  //   it is necessary to specify the (default) value of size as well.
  // mod_d has a new parameter value size=10.
  //   delay retains its default value

  vdff #(10,15) mod_a (.out(out_a), .in(in_a), .clk(clk));
  vdff          mod_b (.out(out_b), .in(in_b), .clk(clk));
  vdff #( 5,12) mod_c (.out(out_c), .in(in_c), .clk(clk));
  vdff #(10)   mod_d (.out(out_d), .in(in_d), .clk(clk));

endmodule

module vdff (out, in, clk);
  parameter size=5, delay=1;
  output [size-1:0] out;
  input [size-1:0] in;
  input      clk;
  logic [size-1:0] out;

  always @(posedge clk)
    #delay out = in;
endmodule

```

Local parameters cannot be overridden; therefore, they are not considered part of the ordered list for parameter value assignment, even if the local parameter appears in a module's *parameter_port_list*. In the following example, `addr_width` will be assigned the value 12, and `data_width` will be assigned the value 16. `mem_size` will not be explicitly assigned a value due to the ordered list, but will have the value 4096 due to its declaration expression.

```

module my_mem (addr, data);
  parameter addr_width = 16;
  localparam mem_size = 1 << addr_width;
  parameter data_width = 8;
  ...
endmodule

```

```

module top;
    ...
    my_mem # (12, 16) m(addr, data);
endmodule

```

23.10.2.2 Parameter value assignment by name

Parameter assignment by name consists of explicitly linking the parameter name and its new value. The name of the parameter shall be the name specified in the instantiated module.

It is not necessary to assign values to all of the parameters within a module when using this method. Only parameters that are assigned new values need to be specified.

The parameter expression is optional so that the instantiating module can document the existence of a parameter without assigning anything to it. The parentheses are required, and in this case the parameter retains its default value. Once a parameter is assigned a value, there shall not be another assignment to this parameter name.

Consider the following example, where both parameters of `mod_a` and only one parameter of `mod_c` and `mod_d` are changed during instantiation:

```

module tb2;
    wire [9:0] out_a, out_d;
    wire [4:0] out_b, out_c;
    logic [9:0] in_a, in_d;
    logic [4:0] in_b, in_c;
    logic      clk;

    // testbench clock & stimulus generation code ...

    // Four instances of vdff with parameter value assignment by name

    // mod_a has new parameter values size=10 and delay=15
    // mod_b has default parameters (size=5, delay=1)
    // mod_c has one default size=5 and one new delay=12
    // mod_d has a new parameter value size=10.
    // delay retains its default value

    vdff #(.size(10),.delay(15)) mod_a (.out(out_a),.in(in_a),.clk(clk));
    vdff                                mod_b (.out(out_b),.in(in_b),.clk(clk));
    vdff #(.delay(12))                mod_c (.out(out_c),.in(in_c),.clk(clk));
    vdff #(.delay( ),.size(10) ) mod_d (.out(out_d),.in(in_d),.clk(clk));

endmodule

module vdff (out, in, clk);
    parameter size=5, delay=1;
    output [size-1:0] out;
    input [size-1:0] in;
    input      clk;
    logic [size-1:0] out;

    always @(posedge clk)
        #delay out = in;
endmodule

```

It shall be legal to instantiate modules using different types of parameter redefinition in the same top-level module. Consider the following example, where the parameters of `mod_a` are changed using parameter redefinition by ordered list and the second parameter of `mod_c` is changed using parameter redefinition by name during instantiation:

```
module tb3;

    // declarations & code

    // legal mixture of instance with positional parameters and
    // another instance with named parameters

    vdff #(10, 15)    mod_a (.out(out_a), .in(in_a), .clk(clk));
    vdff            mod_b (.out(out_b), .in(in_b), .clk(clk));
    vdff #(.delay(12)) mod_c (.out(out_c), .in(in_c), .clk(clk));

endmodule
```

It shall be illegal to instantiate any module using a mixture of parameter redefinitions by order and by name as shown in the instantiation of `mod_a` below:

```
// mod_a instance with ILLEGAL mixture of parameter assignments
vdff #(10, .delay(15)) mod_a (.out(out_a), .in(in_a), .clk(clk));
```

23.10.3 Parameter dependence

A parameter (for example, `memory_size`) can be defined with an expression containing another parameter (for example, `word_size`). However, overriding a parameter, whether by a `defparam` statement or in a module instantiation statement, effectively replaces the parameter definition with the new expression. Because `memory_size` depends on the value of `word_size`, a modification of `word_size` changes the value of `memory_size`. For example, in the following parameter declaration, an update of `word_size`, whether by `defparam` statement or in an instantiation statement for the module that defined these parameters, automatically updates `memory_size`. If `memory_size` is updated due to either a `defparam` or an instantiation statement, then it will take on that value, regardless of the value of `word_size`.

```
parameter
    word_size = 32,
    memory_size = word_size * 4096;
```

Parameters can also have type dependencies on other parameters, including type parameters. Examples of such dependencies are as follows:

```
parameter p = 1;
parameter [p:0] p2 = 4;
parameter type T = int;
parameter T p3 = 7;
```

If parameter `p` changes, the value of `p2` is recomputed based on the new size of the type. If the type parameter `T` changes, the value of `p3` is recomputed. It is possible for an override of a parameter to result in an illegal parameter assignment. For example, if `T` in the above example was overridden to a class type, the evaluation of `p3` would be illegal and would cause elaboration to fail.

If a module instance overrides a type parameter, assignments to parameters that depend on the type parameter shall not occur with the default type.

```

class C ;
endclass

module M # ( type T = C, T p = 4,
            type T2, T2 p2 = 4
            ) () ;

endmodule

```

In the above example, if the type parameter T is not overridden to an integral type, the evaluation of the default value for parameter p is illegal. If T is overridden to an integral type, the default initialization of p shall occur only with the overridden type resulting in a legal initialization. Similarly, since $T2$ requires an instantiation override, the evaluation of $p2$ shall only occur with the type defined by the parameter override.

23.10.4 Elaboration considerations

Elaboration is the process that occurs between parsing and simulation. It binds modules to module instances, builds the model hierarchy, computes parameter values, resolves hierarchical names, establishes net connectivity, and prepares all of this for simulation.

23.10.4.1 Order of elaboration

Because of generate constructs, the model hierarchy can depend on parameter values. Because **defparam** statements can alter parameter values from almost anywhere in the hierarchy, the result of elaboration can be ambiguous when generate constructs are involved. The final model hierarchy can depend on the order in which **defparams** and generate constructs are evaluated.

The following algorithm defines an order that produces the correct hierarchy:

- a) A list of starting points is initialized with the list of top-level modules.
- b) The hierarchy below each starting point is expanded as much as possible without elaborating generate constructs. All parameters encountered during this expansion are given their final values by applying initial values, parameter overrides, and **defparam** statements.

In other words, any **defparam** statement whose target can be resolved within the hierarchy elaborated so far shall have its target resolved and its value applied. **defparam** statements whose target cannot be resolved are deferred until the next iteration of this step. Because no **defparam** inside the hierarchy below a generate construct is allowed to refer to a parameter outside the generate construct, it is possible for parameters to get their final values before going to step c).

- c) Each generate construct encountered in step b) is revisited, and the generate scheme is evaluated. The resulting generate block instantiations make up the new list of starting points. If the new list of starting points is not empty, go to step b).

23.10.4.2 Early resolution of hierarchical names

In order to comply with this algorithm, hierarchical names in some **defparam** statements will need to be resolved prior to the full elaboration of the hierarchy. It is possible that when elaboration is complete, rules for name resolution would dictate that a hierarchical name in a **defparam** statement would have resolved differently had early resolution not been required. This could result in a situation where an identical hierarchical name in some other statement in the same scope would resolve differently from the one in the **defparam** statement. Below is an example of a design that has this problem:

```

module m;
  m1 n ();
endmodule

```

```
module m1;
  parameter p = 2;

  defparam m.n.p = 1;
  initial $display(m.n.p);

  generate
    if (p == 1) begin : m
      m2 n();
    end
  endgenerate
endmodule

module m2;
  parameter p = 3;
endmodule
```

In this example, the **defparam** must be evaluated before the conditional generate is elaborated. At this point in elaboration, the name resolves to **parameter p** in module `mid1`, and this parameter is used in the generate scheme. The result of the **defparam** is to set that parameter to 1; therefore, the generate condition is true. After the hierarchy below the generate construct is elaborated, the rules for hierarchical name resolution would dictate that the name should have resolved to **parameter p** in module `mid2`. In fact, the identical name in the **\$display** statement will resolve to that other parameter.

It shall be an error if a hierarchical name in a **defparam** is resolved before the hierarchy is completely elaborated and that name would resolve differently once the model is completely elaborated.

This situation will occur very rarely. In order to cause the error, there has to be a named generate block that has the same name as one of the scopes in its full hierarchical name. Furthermore, there have to be two instances with the same name, one in the generate block and one in the other scope with the same name as the generate block. Then, inside these instances there have to be parameters with the same name. If this problem occurs, it can be easily fixed by changing the name of the generate block.

23.11 Binding auxiliary code to scopes or instances

It is often desired to keep verification code separate from the design code. SystemVerilog provides a **bind** construct that is used to specify one or more instantiations of a module, interface, program, or checker without modifying the code of the target. So, for example, instrumentation code or assertions that are encapsulated in a module, interface, program, or checker can be instantiated in a target module or a module instance in a non-intrusive manner. Similarly, instrumentation code that is encapsulated in an interface can be bound to a target interface or interface instance.

The syntax of the **bind** construct is as follows in [Syntax 23-9](#).

```
bind_directive4 ::= //from A.1.4
  bind bind_target_scope [ : bind_target_instance_list ] bind_instantiation ;
  | bind bind_target_instance bind_instantiation ;
bind_target_scope ::=
  module_identifier
  | interface_identifier
bind_target_instance ::=
  hierarchical_identifier constant_bit_select
bind_target_instance_list ::=
```

```

bind_target_instance { , bind_target_instance }
bind_instantiation ::=
  program_instantiation
  | module_instantiation
  | interface_instantiation
  | checker_instantiation

```

- 4) If the `bind_target_scope` is an `interface_identifier` or the `bind_target_instance` is an `interface_instance_identifier`, then the `bind_instantiation` shall be an `interface_instantiation` or a `checker_instantiation`.

Syntax 23-9—Bind construct syntax (excerpt from [Annex A](#))

The **bind** directive can be specified in any of the following:

- A module
- An interface
- A compilation-unit scope

There are two forms of bind syntax. In the first form, *bind_target_scope* specifies a target scope into which the *bind_instantiation* should be inserted. A bind target scope shall be a module or an interface. A bind target instance shall be an instance of a module or an interface. In the absence of a *bind_target_instance_list*, the *bind_instantiation* is inserted into all instances of the specified target scope, designwide. If a *bind_target_instance_list* is present, the *bind_instantiation* is only inserted into the specified instances of the target scope. The *bind_instantiation* is effectively a complete module, interface, program, or checker instantiation statement.

The second form of bind syntax can be used to specify a single instance into which the *bind_instantiation* should be inserted. If the second form of bind syntax is used and the *bind_target_instance* identifier resolves to both an instance name and a module name, binding shall only occur to the specified instance.

Example of binding a program instance to a module:

```
bind cpu fpu_props fpu_rules_1(a,b,c);
```

where

- `cpu` is the name of the target module.
- `fpu_props` is the name of the program to be instantiated.
- `fpu_rules_1` is the program instance name to be created in the target scope.
- An instance named `fpu_rules_1` is instantiated in every instance of module `cpu`.
- The first three ports of program `fpu_props` get bound to objects `a`, `b`, and `c` in module `cpu` (these objects are viewed from module `cpu`'s point of view, and they are completely distinct from any objects named `a`, `b`, and `c` that are visible in the scope that contains the **bind** directive).

Example of binding a program instance to a specific instance of a module:

```
bind cpu: cpu1 fpu_props fpu_rules_1(a, b, c);
```

In the example above, the `fpu_rules_1` instance is bound into the `cpu1` instance of module `cpu`.

Example of binding a program instance to multiple instances of a module:

```
bind cpu: cpu1, cpu2, cpu3 fpu_props fpu_rules_1(a, b, c);
```

In the example above, the `fpu_rules_1` instance is bound into instances `cpu1`, `cpu2`, and `cpu3` of module `cpu`.

By binding a program to a module or an instance, the program becomes part of the bound object. The names of assertion-related declarations can be referenced using the SystemVerilog hierarchical naming conventions.

Binding of a module instance or an interface instance works the same way as described for programs above.

```

interface range (input clk, enable, input var int minval, expr);
  property crange_en;
    @(posedge clk) enable |-> (minval <= expr);
  endproperty
  range_chk: assert property (crange_en);
endinterface

bind cr_unit range r1(c_clk,c_en,v_low,(in1&&in2));
  
```

In this example, interface `range` is instantiated in the module `cr_unit`. Effectively, every instance of module `cr_unit` shall contain the interface instance `r1`.

The *bind instantiation* portion of the `bind` statement allows the complete range of SystemVerilog instantiation syntax. In other words, both parameter and port associations may appear in the *bind instantiation*. All actual ports and parameters in the *bind instantiation* refer to objects from the viewpoint of the *bind_target_instance*.

When an instance is bound into a target scope, the effect will be as if the instance was present at the very end of the target scope. In other words, all declarations present in the target scope or imported into the target scope are visible to the bound instance. Wildcard import candidates that have been imported into the scope are visible, but a `bind` statement cannot cause the import of a wildcard candidate. Declarations present or imported into `$unit` are not visible in the `bind` statement.

User defined type names that are used to override type parameters must be visible and matching in both the scope containing the `bind` statement and in the target scope.

If multiple `bind` statements are present in a given scope, the order of those statements is not important. An implementation is free to elaborate `bind` statements in any order it chooses.

The following is an example of a module containing a `bind` statement with complex instantiation syntax. All identifiers in the `bind` instantiation are referenced from the `bind target's` point of view in the overall design hierarchy.

```

bind targetmod
  mycheck #(.param1(const4), .param2(8'h44))
  i_mycheck(.*, .p1(f1({v1, 1'b0, b1.c}, v2 & v3)), .p2(top.v4));
  
```

If any controlling configuration library mapping is in effect at the time a `bind` statement is encountered, the mapping associated with the `bind` statement shall influence the elaboration of the *bind instantiation* statement. In all cases, library mapping associated with the *bind_target_instance* shall be ignored during elaboration of the *bind instantiation*.

It shall be an error to use noninstance-based binding if the design contains more than one variation of the target module, interface, or program. This can occur in the presence of configuration library mapping or nonstandard functionality such as provided by the ``uselib` directive. In such cases, users must use instance-based binding syntax to disambiguate between the multiple variations of the target.

Any **defparam** statement located at a lower level of the *bind_instantiation*'s hierarchy shall not extend influence outside the scope of that local hierarchy. This is similar to the rules for use of **defparam** inside the scope of generated hierarchy.

Hierarchical references to a *bind_instantiation*'s parameters may not be used outside the instantiation in any context that requires a constant expression. Examples of such contexts include type descriptions and generate conditions.

It is legal for more than one **bind** statement to bind a *bind_instantiation* into the same target scope. However, it shall be an error for a *bind_instantiation* to introduce an instance name that clashes with another name in the module name space of the target scope (see [3.13](#)). This applies to both pre-existing names as well as instance names introduced by other **bind** statements. The latter situation will occur if the design contains more than one instance of a module containing a **bind** statement.

It shall be an error for a **bind** statement to bind a *bind_instantiation* underneath the scope of another *bind_instantiation*.

24. Programs

24.1 General

This clause describes the following:

- Program declarations
- Program scheduling semantics
- Programs in conjunction with clocking blocks
- Anonymous programs

24.2 Overview

The module is the basic building block for designs. Modules can contain hierarchies of other modules, nets, variables, subroutine declarations, and procedural statements within always and initial procedures. This construct works extremely well for the description of hardware. However, for the testbench, the emphasis is not in the hardware-level details such as wires, structural hierarchy, and interconnects, but in modeling the complete environment in which a design is verified. The environment must be properly initialized and synchronized, avoiding races between the design and the testbench, automating the generation of input stimuli, and reusing existing models and other infrastructure.

The program block serves the following three basic purposes:

- It provides an entry point to the execution of testbenches.
- It creates a scope that encapsulates programwide data, tasks, and functions.
- It provides a syntactic context that specifies scheduling in the reactive region set.

The program construct serves as a clear separator between design and testbench, and, more importantly, it specifies specialized execution semantics in the reactive region set for all elements declared within the program. Together with clocking blocks, the program construct provides for race-free interaction between the design and the testbench and enables cycle- and transaction-level abstractions.

The abstraction and modeling constructs of SystemVerilog simplify the creation and maintenance of testbenches. The ability to instantiate and individually connect each program instance enables their use as generalized models.

24.3 The program construct

A typical program contains type and data declarations, subroutines, connections to the design, and one or more procedural code streams. The connection between design and testbench uses the same interconnect mechanism used to specify port connections, including interfaces. Program port declaration syntax and semantics are the same as those of modules (see [23.2.2](#)).

The syntax for the program block is as follows:

```

program_nonansi_header ::= // from A.1.2
    { attribute_instance } program [ lifetime ] program_identifier
    { package_import_declaration } [ parameter_port_list ] list_of_ports ;
program_ansi_header ::=
    { attribute_instance } program [ lifetime ] program_identifier
    { package_import_declaration }1 [ parameter_port_list ] [ list_of_port_declarations ] ;

```

```

program_declaration ::=
    program_nonansi_header [ timeunits_declaration ] { program_item }
    endprogram [ : program_identifier ]
| program_ansi_header [ timeunits_declaration ] { non_port_program_item }
    endprogram [ : program_identifier ]
| { attribute_instance } program program_identifier ( .* ) ;
    [ timeunits_declaration ] { program_item }
    endprogram [ : program_identifier ]
| extern program_nonansi_header
| extern program_ansi_header

program_item ::= // from A.1.7
    port_declaration ;
| non_port_program_item

non_port_program_item ::=
    { attribute_instance } continuous_assign
| { attribute_instance } module_or_generate_item_declaration
| { attribute_instance } initial_construct
| { attribute_instance } final_construct
| { attribute_instance } concurrent_assertion_item
| { attribute_instance } timeunits_declaration3
| program_generate_item

program_generate_item5 ::=
    loop_generate_construct
| conditional_generate_construct
| generate_region

lifetime ::= static | automatic // from A.2.1.3

anonymous_program ::= program ; { anonymous_program_item } endprogram // from A.1.11

anonymous_program_item ::=
    task_declaration
| function_declaration
| class_declaration
| covergroup_declaration
| class_constructor_declaration
| ;

```

- 3) A `timeunits_declaration` shall be legal as a `non_port_module_item`, `non_port_interface_item`, `non_port_program_item`, or `package_item` only if it repeats and matches a previous `timeunits_declaration` within the same time scope.
- 5) It shall be illegal for a `program_generate_item` to include any item that would be illegal in a `program_declaration` outside a `program_generate_item`.
- 1) A `package_import_declaration` in a `module_ansi_header`, `interface_ansi_header`, or `program_ansi_header` shall be followed by a `parameter_port_list` or `list_of_port_declarations`, or both.

Syntax 24-1—Program declaration syntax (excerpt from [Annex A](#))

For example:

```

program test (input clk, input [16:1] addr, inout [7:0] data);
    initial ...
endprogram

```

or

```

program test ( interface device_ifc );
  initial ...
endprogram

```

A more complete example is included in [14.8](#) and [14.9](#).

The **program** construct can be considered a leaf module with special execution semantics. Once declared, a program block can be instantiated in the required hierarchical location (typically at the top level), and its ports can be connected in the same manner as any other module.

Program blocks can be nested within modules or interfaces. This allows multiple cooperating programs to share variables local to the scope. Nested programs with no ports or top-level programs that are not explicitly instantiated are implicitly instantiated once. Implicitly instantiated programs have the same instance and declaration name. For example:

```

module test(...);
  int shared; // variable shared by programs p1 and p1

  program p1;
  ...
endprogram

  program p2;
  ...
endprogram // p1 and p2 are implicitly instantiated once in module test

endmodule

```

A program block may contain one or more initial or final procedures. It shall not contain always procedures, primitives, UDPs, or declarations or instances of modules, interfaces, or other programs.

When all initial procedures within a program have reached their end, that program shall immediately terminate all descendent threads of initial procedures within that program. If there is at least one initial procedure within at least one program block, the entire simulation shall terminate by means of an implicit call to the `$finish` system task immediately after all the threads and all their descendent threads originating from all initial procedures within all programs have ended.

Type and data declarations within the program are local to the program scope and have static lifetime. Variables declared within the scope of a program, including variables declared as ports, are called *program variables*. Similarly, nets declared within the scope of a program are called *program nets*. Program variables and nets are collectively termed *program signals*.

The dual of a program signal is a *design signal*. Any net or variable declared within a **module**, **interface**, **package**, or **\$unit** is considered to be a design signal.

References to program signals from outside any program block shall be an error. It shall be legal for hierarchical references to extend from one program scope to another program scope. However, anonymous programs shall not contain hierarchical references to other program scopes.

24.3.1 Scheduling semantics of code in program constructs

Statements and constructs within a program block that are sensitive to changes (e.g., update events) on design signals are scheduled in the Reactive region. Consider a program that contains the statement

@(clk) S1; where `clk` is a design signal. Every transition of signal `clk` will cause the statement `S1` to be scheduled into the Reactive region. The continuous assignment `assign tclk = clk;` would also be scheduled in the Reactive region. Likewise, initial procedures within program blocks are scheduled in the Reactive region. The standard # delay operator within program blocks schedules process resumption in the Reactive region.

Nonblocking assignments in program code schedule their updates in the Re-NBA region. The Re-NBA region is processed after the Reactive and Re-Inactive regions have been emptied of events. See [4.2](#).

Concurrent assertions are allowed in program blocks. Concurrent assertions have invariant scheduling semantics—whether present in program code or design code. Assertions always sample the values available while processing the Preponed region and they are always evaluated when processing the Observed region. If an assertion is clocked by activity on a program object (not recommended), the scheduler will iterate from the reactive region set back around the outer loop in [Figure 4-1](#), through the Observed region, where the assertion is evaluated.

Once a program process starts a thread of execution, all subsequent blocking statements in that thread are scheduled in the Reactive region. This includes subroutine code called by the thread, even if the subroutine code is declared in a module, package, or interface. Effectively, a section of sequential code anywhere in the design or testbench inherits the scheduling region of the thread that calls it. Since program code can never be called by module code, program code always executes as part of the reactive set processing. Code in a module, interface, or package scope may execute as part of either the Active region set or the reactive set processing.

24.3.2 Operation of program port connections in the absence of clocking blocks

The interaction of clocking blocks with program ports is described in [Clause 14](#). Clocking blocks are an important component in establishing race-free behavior between designs and testbenches. However, it is possible to construct a program that contains no clocking blocks. Such programs are more prone to races when interacting with design code. This subclause defines the interaction of program ports with design code in the absence of clocking blocks.

Program ports are program-scope objects. They are always connected to design objects (nets and variables), since programs can only be instantiated in design scopes.

Sequential code declared in programs always executes in the reactive region set. Thus, variables on the other side of a program port connection are updated in the reactive region set. Similarly, the driving and resolution of nets on the other side of a program port connection also occurs in the reactive region set. Such driving and resolution occurs immediately after an event causes a change to a driver on a program net. Design processes sensitive to those cross-region variables and nets are scheduled for wake up in the active region set.

Consider the following example design, which contains both design constructs and program constructs:

```
module m;
  logic r;
  wire dw1, dw2;

  initial begin
    r = 0;
    #10 r = 1;
  end

  assign dw1 = r;

  p p_i(dw2, dw1);
```

```

    always @(dw2)
        $display("dw2 is %b", dw2);
endmodule

program p(output pw2, input pw1);
    assign pw2 = pw1;
endprogram

```

In this design, the flow of data originates in **logic** *r* and terminates in the execution of the **always** procedure. Due to the presence of **program** *p*, it is necessary for simulators to perform multiple iterations over the entire loop in [Figure 4-1](#). This is because the **assign** statement in **program** *p* shall not be executed until the Reactive region. And when it executes and triggers activity on the **always** procedure in **module** *m*, that **always** procedure is not executed until the Active region in the next iteration of the overall scheduling loop.

24.4 Eliminating testbench races

There are two major sources of nondeterminism in SystemVerilog. The first one is that active events are processed in an arbitrary order. The second one is that statements without time control constructs in behavioral blocks do not execute as one event. However, from the testbench perspective, these effects are all unimportant details. The primary task of a testbench is to generate valid input stimulus for the design under test and to verify that the device operates correctly. Furthermore, testbenches that use cycle abstractions are only concerned with the stable or steady state of the system for both checking the current outputs and for computing stimuli for the next cycle. Formal tools also work in this fashion.

Because the program schedules events in the reactive region set, the clocking block construct is very useful to automatically sample the steady-state values of previous time steps or clock cycles. Programs that read design values exclusively through clocking blocks with clocks that are design signals are insensitive to read-write races. It is important to understand that simply sampling input signals (or setting nonzero skews on clocking block inputs) does not eliminate the potential for races. Proper input sampling only addresses a single clocking block. With multiple clocks, the arbitrary order in which overlapping or simultaneous clocks are processed is still a potential source for races. The program construct addresses this issue by scheduling its execution in the Reactive region, after all design events have been processed, including clocks driven by nonblocking assignments.

24.5 Blocking tasks in cycle/event mode

Calling program subroutines from within design modules is illegal and shall result in an error. This is because the design should not be aware of the testbench. Programs are allowed to call subroutines in other programs or within design modules. Functions within design modules can be called from a program and require no special handling. When a task within a design module is called from a program, it shall use the reactive region set for its scheduling activities. See [24.3.1](#).

```

module ...
    task T;
        S1: a = b;      // executes in reactive region set if called from a program
        #5;
        S2: b <= 1'b1; // executes in reactive region set if called from a program
    endtask
endmodule

```

If task *T*, above, is called from within a module, then the statement *S1* can execute immediately when the Active region is processed, before variable *b* is updated by the nonblocking assignment. If the same task is

called from within a program, then the statement *S*₁ shall execute when the Reactive region is processed. Statement *S*₂ shall also execute in the Reactive region, and variable *b*'s update shall be scheduled in the Re-NBA region.

24.6 Programwide space and anonymous programs

The set of program definitions and instances define a space of programwide data, tasks, and functions that is accessible only to programs.

Anonymous programs can be used inside packages (see [Clause 26](#)) or compilation-unit scopes (see [3.12.1](#)) to declare items that are part of the programwide space without declaring a new scope. Items declared in an anonymous program share the same name space as the package or compilation-unit scope in which they are declared.

NOTE—Although identifiers declared inside an anonymous program cannot be referenced outside any program block, attempting to declare another identifier with the same name outside the anonymous program block will generate an error. This occurs because the identifier shares the same name space within the scope of the surrounding package or compilation unit.

24.7 Program control tasks

In addition to the normal simulation control tasks (*\$stop* and *\$finish*), a program can use the *\$exit* control task.

A program block may terminate the threads of all its initial procedures as well as all of their descendents explicitly by calling the *\$exit* system task. The syntax for the *\$exit* system task is as follows:

```
$exit();
```

Calling *\$exit* from a thread or its descendent thread originating in an **initial** procedure of a program block shall terminate all initial procedures and their descendent threads within that originating program block. Calling *\$exit* from a thread or its descendent thread that does not originate in an **initial** procedure in a program shall be ignored, and a warning may be issued to indicate that the call to *\$exit* has been ignored.

25. Interfaces

25.1 General

This clause describes the following:

- Purpose of interfaces
- Interface syntax
- Interface modports
- Interface methods
- Parameterized interfaces
- Virtual interfaces
- Accessing interface objects

25.2 Overview

The communication between blocks of a digital system is a critical area that can affect everything from ease of RTL coding to hardware-software partitioning to performance analysis to bus implementation choices and protocol checking. The interface construct in SystemVerilog was specifically created to encapsulate the communication between blocks, allowing a smooth migration from abstract system-level design through successive refinement down to lower level register-transfer and structural views of the design. By encapsulating the communication between blocks, the interface construct also facilitates design reuse. The inclusion of interface capabilities is an important advantage of SystemVerilog.

At its lowest level, an interface is a named bundle of nets or variables. The interface is instantiated in a design and can be accessed through a port as a single item, and the component nets or variables referenced where needed. A significant proportion of a design often consists of port lists and port connection lists, which are just repetitions of names. The ability to replace a group of names by a single name can significantly reduce the size of a description and improve its maintainability.

Additional power of the interface comes from its ability to encapsulate functionality as well as connectivity, making an interface, at its highest level, more like a class template. An interface can have parameters, constants, variables, functions, and tasks. The types of elements in an interface can be declared, or the types can be passed in as parameters. The member variables and functions are referenced relative to the instance name of the interface as instance members. Thus, modules that are connected via an interface can simply call the subroutine members of that interface to drive the communication. With the functionality thus encapsulated in the interface and isolated from the module, the abstraction level and/or granularity of the communication protocol can be easily changed by replacing the interface with a different interface containing the same members, but implemented at a different level of abstraction. The modules connected via the interface do not need to change at all.

To provide direction information for module ports and to control the use of tasks and functions within particular modules, the **modport** construct is provided. As the name indicates, the directions are those seen from the module.

In addition to subroutine methods, an interface can also contain processes (i.e., **initial** or **always** procedures) and continuous assignments, which are useful for system-level modeling and testbench applications. This allows the interface to include, for example, its own protocol checker that automatically verifies that all modules connected via the interface conform to the specified protocol. Other applications, such as functional coverage recording and reporting, protocol checking, and assertions can also be built into the interface.

The methods can be abstract, i.e., defined in one module and called in another, using the **export** and **import** constructs. This could be coded using hierarchical path names, but this would impede reuse because the names would be design-specific. A better way is to declare the subroutine names in the interface and to use local hierarchical names from the interface instance for both definition and call. Broadcast communication is modeled by **forkjoin** tasks, which can be defined in more than one module and executed concurrently.

25.3 Interface syntax

```

interface_declaration ::=
    interface_nonansi_header [ timeunits_declaration ] { interface_item }
    //from A.1.2
    endinterface [ : interface_identifier ]
| interface_ansi_header [ timeunits_declaration ] { non_port_interface_item }
    endinterface [ : interface_identifier ]
| { attribute_instance } interface interface_identifier ( .* ) ;
    [ timeunits_declaration ] { interface_item }
    endinterface [ : interface_identifier ]
| extern interface_nonansi_header
| extern interface_ansi_header
interface_nonansi_header ::=
    { attribute_instance } interface [ lifetime ] interface_identifier
    { package_import_declaration } [ parameter_port_list ] list_of_ports ;
interface_ansi_header ::=
    { attribute_instance } interface [ lifetime ] interface_identifier
    { package_import_declaration }1 [ parameter_port_list ] [ list_of_port_declarations ] ;
modport_declaration ::= modport modport_item { , modport_item } ;
//from A.2.9
modport_item ::= modport_identifier ( modport_ports_declaration { , modport_ports_declaration } )
modport_ports_declaration ::=
    { attribute_instance } modport_simple_ports_declaration
| { attribute_instance } modport_tf_ports_declaration
| { attribute_instance } modport_clocking_declaration
modport_clocking_declaration ::= clocking clocking_identifier
modport_simple_ports_declaration ::=
    port_direction modport_simple_port { , modport_simple_port }
modport_simple_port ::=
    port_identifier
| . port_identifier ( [ expression ] )
modport_tf_ports_declaration ::=
    import_export modport_tf_port { , modport_tf_port }
modport_tf_port ::=
    method_prototype
| tf_identifier
import_export ::= import | export
interface_instantiation ::=
    interface_identifier [ parameter_value_assignment ] hierarchical_instance { , hierarchical_instance } ;
//from A.4.1.2

```

1) A package_import_declaration in a module_ansi_header, interface_ansi_header, or program_ansi_header shall be followed by a parameter_port_list or list_of_port_declarations, or both.

The interface construct provides a new hierarchical structure. It can contain smaller interfaces and can be passed through ports.

The aim of interfaces is to encapsulate communication. At the lower level, this means bundling variables and nets in interfaces and can impose access restrictions with port directions in modports. The modules can be made generic so that the interfaces can be changed. The following examples show these features. At a higher level of abstraction, communication can be done by tasks and functions. Interfaces can include subroutine definitions or just subroutine prototypes, with the definition in one module and the call in another (see [25.7](#) and [25.7.3](#)).

A simple interface declaration is as follows (see [Syntax 25-1](#) for the complete syntax):

```
interface identifier;
    ...
    interface_items
    ...
endinterface [ : identifier ]
```

An interface can be instantiated hierarchically like a module, with or without ports. For example:

```
myinterface #(100) scalar1(), vector[9:0]();
```

In this example, 11 instances of the interface of type `myinterface` have been instantiated, and the first parameter within each interface is changed to 100. One `myinterface` instance is instantiated with the name `scalar1`, and an array of 10 `myinterface` interfaces are instantiated with instance names `vector[9]` to `vector[0]`.

Interfaces can be declared and instantiated in modules (either flat or hierarchical), but modules can neither be declared nor instantiated in interfaces. In contrast to modules (see [23.3](#)) and programs (see [24.3](#)), interfaces are never implicitly instantiated.

A `defparam` within an instance whose port actuals refer to an arrayed interface shall not modify a parameter outside the hierarchy of such an instance. If the actual of an interface port connection is a hierarchical reference to an interface or a modport of a hierarchically referenced interface, the hierarchical reference shall refer to an interface instance and shall not resolve through an arrayed instance or a `generate` block.

The simplest use of an interface is to bundle wires, as illustrated in the examples below.

25.3.1 Example without using interfaces

This example shows a simple bus implemented without interfaces.

```
module memMod( input    logic req,
               logic clk,
               logic start,
               logic [1:0] mode,
               logic [7:0] addr,
               inout   wire [7:0] data,
               output   bit gnt,
               output   bit rdy );
    logic avail;
    ...
endmodule

module cpuMod(
```

```

    input    logic clk,
            logic gnt,
            logic rdy,
    inout   wire [7:0] data,
    output   logic req,
            logic start,
            logic [7:0] addr,
            logic [1:0] mode );
    ...
endmodule

module top;
    logic req, gnt, start, rdy;
    logic clk = 0;
    logic [1:0] mode;
    logic [7:0] addr;
    wire [7:0] data;

    memMod mem(req, clk, start, mode, addr, data, gnt, rdy);
    cpuMod cpu(clk, gnt, rdy, data, req, start, addr, mode);

endmodule

```

25.3.2 Interface example using a named bundle

The simplest form of a SystemVerilog interface is a bundled collection of variables or nets. When an interface is referenced as a port, the variables and nets in it are assumed to have **ref** and **inout** access, respectively. The following interface example shows the basic syntax for defining, instantiating, and connecting an interface. Usage of the SystemVerilog interface capability can significantly reduce the amount of code required to model port connections.

```

interface simple_bus; // Define the interface
    logic req, gnt;
    logic [7:0] addr, data;
    logic [1:0] mode;
    logic start, rdy;
endinterface: simple_bus

module memMod(simple_bus a, // Access the simple_bus interface
              input logic clk);
    logic avail;
    // When memMod is instantiated in module top, a.req is the req
    // signal in the sb_intf instance of the 'simple_bus' interface
    always @(posedge clk) a.gnt <= a.req & avail;
endmodule

module cpuMod(simple_bus b, input logic clk);
    ...
endmodule

module top;
    logic clk = 0;

    simple_bus sb_intf(); // Instantiate the interface

    memMod mem(sb_intf, clk); // Connect the interface to the module instance
    cpuMod cpu(.b(sb_intf), .clk(clk)); // Either by position or by name

```

```
endmodule
```

In the preceding example, if the same identifier, `sb_intf`, had been used to name the `simple_bus` interface in the `memMod` and `cpuMod` module headers, then implicit port connections also could have been used to instantiate the `memMod` and `cpuMod` modules into the top module, as follows:

```
module memMod (simple_bus sb_intf, input logic clk);
    ...
endmodule

module cpuMod (simple_bus sb_intf, input logic clk);
    ...
endmodule

module top;
    logic clk = 0;

    simple_bus sb_intf();

    memMod mem (.*); // implicit port connections
    cpuMod cpu (.*); // implicit port connections

endmodule
```

25.3.3 Interface example using a generic bundle

A module header can be created with an unspecified interface reference as a placeholder for an interface to be selected when the module itself is instantiated. The unspecified interface is referred to as a *generic interface reference*.

This generic interface reference can only be declared using the ANSI style *list_of_port_declarations* syntax (see [23.2.2.2](#)). It shall be illegal to declare such a generic interface reference using the non-ANSI style *list_of_ports* syntax (see [23.2.2.1](#)).

The following interface example shows how to specify a generic interface reference in a module definition:

```
// memMod and cpuMod can use any interface
module memMod (interface a, input logic clk);
    ...
endmodule

module cpuMod(interface b, input logic clk);
    ...
endmodule

interface simple_bus; // Define the interface
    logic req, gnt;
    logic [7:0] addr, data;
    logic [1:0] mode;
    logic start, rdy;
endinterface: simple_bus

module top;
    logic clk = 0;

    simple_bus sb_intf(); // Instantiate the interface
```

```
// Reference the sb_intf instance of the simple_bus
// interface from the generic interfaces of the
// memMod and cpuMod modules
memMod mem (.a(sb_intf), .clk(clk));
cpuMod cpu (.b(sb_intf), .clk(clk));

endmodule
```

An implicit port cannot be used to reference a generic interface. A named port shall be used to reference a generic interface, as follows:

```
module memMod (interface a, input logic clk);
    ...
endmodule

module cpuMod (interface b, input logic clk);
    ...
endmodule

module top;
    logic clk = 0;

    simple_bus sb_intf();

    memMod mem (.*, .a(sb_intf)); // partial implicit port connections
    cpuMod cpu (.*, .b(sb_intf)); // partial implicit port connections

endmodule
```

25.4 Ports in interfaces

One limitation of simple interfaces is that the nets and variables declared within the interface are only used to connect to a port with the same nets and variables. To share an external net or variable, one that makes a connection from outside the interface as well as forming a common connection to all module ports that instantiate the interface, an interface port declaration is required. The difference between nets or variables in the interface port list and other nets or variables within the interface is that only those in the port list can be connected externally by name or position when the interface is instantiated. Interface port declaration syntax and semantics are the same as those of modules (see [23.2.2](#)).

```
interface i1 (input a, output b, inout c);
    wire d;
endinterface
```

The wires a, b, and c can be individually connected to the interface and thus shared with other interfaces.

The following example shows how to specify an interface with inputs, allowing a wire to be shared between two instances of the interface:

```
interface simple_bus (input logic clk); // Define the interface
    logic req, gnt;
    logic [7:0] addr, data;
    logic [1:0] mode;
    logic start, rdy;
endinterface: simple_bus

module memMod(simple_bus a); // Uses just the interface
```

```

    logic avail;

    always @(posedge a.clk) // the clk signal from the interface
        a.gnt <= a.req & avail; // a.req is in the 'simple_bus' interface
endmodule

module cpuMod(simple_bus b);
    ...
endmodule

module top;
    logic clk = 0;

    simple_bus sb_intf1(clk); // Instantiate the interface
    simple_bus sb_intf2(clk); // Instantiate the interface

    memMod mem1(.a(sb_intf1)); // Reference simple_bus 1 to memory 1
    cpuMod cpu1(.b(sb_intf1));
    memMod mem2(.a(sb_intf2)); // Reference simple_bus 2 to memory 2
    cpuMod cpu2(.b(sb_intf2));

endmodule

```

In the preceding example, the instantiated interface names do not match the interface names used in the `memMod` and `cpuMod` modules; therefore, implicit port connections cannot be used for this example.

25.5 Modports

To restrict interface access within a module, there are `modport` lists with directions declared within the interface. The keyword `modport` indicates that the directions are declared as if inside the module.

```

interface i2;
    wire a, b, c, d;
    modport master (input a, b, output c, d);
    modport slave (output a, b, input c, d);
endinterface

```

In this example, the `modport` list name (`master` or `slave`) can be specified in the module header, where the interface name selects an interface and the `modport` name selects the appropriate directional information for the interface signals accessed in the module header.

```

module m (i2.master i);
    ...
endmodule

module s (i2.slave i);
    ...
endmodule

module top;
    i2 i();

    m u1(.i(i));
    s u2(.i(i));
endmodule

```

The syntax of `interface_name.modport_name reference_name` gives a local name for a hierarchical reference. This technique can be generalized to any interface with a given modport name by writing `interface.modport_name reference_name`.

The **modport** list name (master or slave) can also be specified in the port connection with the module instance, where the **modport** name is hierarchical from the interface instance.

```

module m (i2 i);
    ...
endmodule

module s (i2 i);
    ...
endmodule

module top;
    i2 i();

    m u1(.i(i.master));
    s u2(.i(i.slave));
endmodule

```

If a port connection specifies a **modport** list name in both the module instance and module header declaration, then the two **modport** list names shall be identical.

All of the names used in a **modport** declaration shall be declared by the same interface as the modport itself. In particular, the names used shall not be those declared by another enclosing interface, and a modport declaration shall not implicitly declare new ports.

The following interface declarations would be illegal:

```

interface i;
    wire x, y;

    interface illegal_i;
        wire a, b, c, d;
        // x, y not declared by this interface
        modport master(input a, b, x, output c, d, y);
        modport slave(output a, b, x, input c, d, y);
    endinterface : illegal_i

endinterface : i

interface illegal_i;
    // a, b, c, d not declared by this interface
    modport master(input a, b, output c, d);
    modport slave(output a, b, input c, d);
endinterface : illegal_i

```

Adding modports to an interface does not require that any of the modports be used when the interface is used. If no **modport** is specified in the module header or in the port connection, then all the nets and variables in the interface are accessible with direction **inout** or **ref**, as in the examples above.

25.5.1 Example of named port bundle

This interface example shows how to use modports to control signal directions as in port declarations. It uses the modport name in the module definition.

```

interface simple_bus (input logic clk); // Define the interface
  logic req, gnt;
  logic [7:0] addr, data;
  logic [1:0] mode;
  logic start, rdy;

  modport slave (input req, addr, mode, start, clk,
                output gnt, rdy,
                ref data);

  modport master(input gnt, rdy, clk,
                output req, addr, mode, start,
                ref data);

endinterface: simple_bus

module memMod (simple_bus.slave a); // interface name and modport name
  logic avail;

  always @(posedge a.clk) // the clk signal from the interface
    a.gnt <= a.req & avail; // the gnt and req signal in the interface
endmodule

module cpuMod (simple_bus.master b);
  ...
endmodule

module top;
  logic clk = 0;

  simple_bus sb_intf(clk); // Instantiate the interface

  initial repeat(10) #10 clk++;

  memMod mem(.a(sb_intf)); // Connect the interface to the module instance
  cpuMod cpu(.b(sb_intf));
endmodule

```

25.5.2 Example of connecting port bundle

This interface example shows how to use modports to restrict interface signal access and control their direction. It uses the modport name in the module instantiation.

```

interface simple_bus (input logic clk); // Define the interface
  logic req, gnt;
  logic [7:0] addr, data;
  logic [1:0] mode;
  logic start, rdy;

  modport slave (input req, addr, mode, start, clk,
                output gnt, rdy,
                ref data);

```



```

    modport master(input gnt, rdy, clk,
                  output req, addr, mode, start,
                  ref data);

endinterface: simple_bus

module memMod(simple_bus a); // Uses just the interface name
    logic avail;

    always @(posedge a.clk) // the clk signal from the interface
        a.gnt <= a.req & avail; // the gnt and req signal in the interface
endmodule

module cpuMod(simple_bus b);
    ...
endmodule

module top;
    logic clk = 0;

    simple_bus sb_intf(clk); // Instantiate the interface

    initial repeat(10) #10 clk++;

    memMod mem(sb_intf.slave); // Connect the modport to the module instance
    cpuMod cpu(sb_intf.master);
endmodule

```

25.5.3 Example of connecting port bundle to generic interface

This interface example shows how to use modports to control signal directions. It shows the use of the **interface** keyword in the module definition. The actual interface and modport are specified in the module instantiation.

```

interface simple_bus (input logic clk); // Define the interface
    logic req, gnt;
    logic [7:0] addr, data;
    logic [1:0] mode;
    logic start, rdy;

    modport slave (input req, addr, mode, start, clk,
                  output gnt, rdy,
                  ref data);

    modport master(input gnt, rdy, clk,
                  output req, addr, mode, start,
                  ref data);

endinterface: simple_bus

module memMod(interface a); // Uses just the interface
    logic avail;

    always @(posedge a.clk) // the clk signal from the interface
        a.gnt <= a.req & avail; // the gnt and req signal in the interface
endmodule

module cpuMod(interface b);

```

```

...
endmodule

module top;
  logic clk = 0;

  simple_bus sb_intf(clk); // Instantiate the interface

  memMod mem(sb_intf.slave); // Connect the modport to the module instance
  cpuMod cpu(sb_intf.master);
endmodule

```

25.5.4 Modport expressions

A modport expression allows elements of arrays and structures, concatenations of elements, and assignment pattern expressions of elements declared in an interface to be included in a modport list. This modport expression is explicitly named with a port identifier, visible only through the modport connection.

Like explicitly named ports in a module port declaration, port identifiers exist in their own name space for each modport list. When a modport item is just a simple port identifier, that identifier is used as both a reference to an interface item and a port identifier. Once a port identifier has been defined, there shall not be another port definition with this same name.

For example:

```

interface I;
  logic [7:0] r;
  const int x=1;
  bit R;
  modport A (output .P(r[3:0]), input .Q(x), R);
  modport B (output .P(r[7:4]), input .Q(2), R);
endinterface

module M (interface i);
  initial i.P = i.Q;
endmodule

module top;
  I i1 ();
  M u1 (i1.A);
  M u2 (i1.B);
  initial #1 $display("%b", i1.r); // displays 00100001
endmodule

```

The self-determined type of the port expression becomes the type for the port. The port expression shall not be considered an assignment-like context. The port expression shall resolve to a legal expression for type of module port (see [23.3.3](#)). In the example above, the Q port could not be an output or inout because the port expression is a constant. The port expression is optional because ports can be defined that do not connect to anything internal to the port.

The following example illustrates how a bus with a parameterizable number of clients can be described:

```

// Bus interface with parameterized number of client modports
interface intf_t #(num_clients = 0);
  bit [num_clients-1:0] req;

  for (genvar i=0; i< num_clients; i++) begin: mps

```

```

        modport client_mp (output .client_req( req[i] ));
    end
endinterface

// A generic client that attaches to the bus
module client_m (interface client_ifc);
    // ... code will drive client_ifc.client_req
endmodule

// The bus system with N clients
module bus #(N = 0);
    intf_t #(.num_clients(N)) intf();

    for (genvar j=0; j < N; j++) begin: clients
        client_m client (.client_ifc (intf.mps[j].client_mp));
    end
endmodule

```

25.5.5 Clocking blocks and modports

The **modport** construct can also be used to specify the direction of **clocking** blocks declared within an interface. As with other **modport** declarations, the directions of the **clocking** block are those seen from the module in which the interface becomes a port. The syntax for this is shown in [Syntax 25-2](#).

```

modport_declaration ::= modport modport_item { , modport_item } ; // from A.2.9
modport_item ::= modport_identifier ( modport_ports_declaration { , modport_ports_declaration } )
modport_ports_declaration ::=
    { attribute_instance } modport_simple_ports_declaration
    | { attribute_instance } modport_tf_ports_declaration
    | { attribute_instance } modport_clocking_declaration
modport_clocking_declaration ::= clocking clocking_identifier

```

Syntax 25-2—Modport clocking declaration syntax (excerpt from [Annex A](#))

All of the **clocking** blocks used in a **modport** declaration shall be declared by the same interface as the modport itself. Like all **modport** declarations, the direction of the clocking signals are those seen from the module in which the interface becomes a port. The example below shows how modports can be used to create both synchronous as well as asynchronous ports. When used in conjunction with virtual interfaces (see [25.9.2](#)), these constructs facilitate the creation of abstract synchronous models.

```

interface A_Bus( input logic clk );
    wire req, gnt;
    wire [7:0] addr, data;

    clocking sb @(posedge clk);
        input gnt;
        output req, addr;
        inout data;

    property p1; req ##[1:3] gnt; endproperty
endclocking

modport DUT ( input clk, req, addr, // Device under test modport
              output gnt,

```

```

        inout data );

    modport STB ( clocking sb );           // synchronous testbench modport

    modport TB ( input gnt,               // asynchronous testbench modport
                output req, addr,
                inout data );
endinterface

```

The above interface `A_Bus` can then be instantiated as follows:

```

module dev1(A_Bus.DUT b);    // Some device: Part of the design
    ...
endmodule

module dev2(A_Bus.DUT b);    // Some device: Part of the design
    ...
endmodule

module top;
    logic clk;

    A_Bus b1( clk );
    A_Bus b2( clk );

    dev1 d1( b1 );
    dev2 d2( b2 );

    T tb( b1, b2 );
endmodule

program T (A_Bus.STB b1, A_Bus.STB b2 ); // testbench: 2 synchronous ports

    assert property (b1.sb.p1); // assert property from within program

    initial begin
        b1.sb.req <= 1;
        wait( b1.sb.gnt == 1 );
        ...
        b1.sb.req <= 0;
        b2.sb.req <= 1;
        wait( b2.sb.gnt == 1 );
        ...
        b2.sb.req <= 0;
    end
endprogram

```

The example above shows the program block using the synchronous interface designated by the clocking modport of interface ports `b1` and `b2`. In addition to the procedural drives and samples of the `clocking` block signals, the program asserts the property `p1` of one of its interfaces `b1`.

25.6 Interfaces and specify blocks

The `specify` block is used to describe various paths across a module and perform timing checks to verify that events occurring at the module inputs satisfy the timing constraints of the device described by the module. The module paths are from module input ports to output ports, and the timing checks are relative to the module inputs. The `specify` block refers to these ports as terminal descriptor. Module `inout` ports can

function as either an input or output terminal. When one of the port instances is an interface, each signal in the interface becomes an available terminal, with the default direction as defined for an interface or as restricted by a **modport**. A **ref** port cannot be used as a terminal in a **specify** block.

The following shows an example of using interfaces together with a **specify** block:

```
interface itf;
  logic c,q,d;
  modport flop (input c,d, output q);
endinterface

module dtype (itf.flop ch);
  always_ff @(posedge ch.c) ch.q <= ch.d;

  specify
    (posedge ch.c => (ch.q+:ch.d)) = (5,6);
    $setup( ch.d, posedge ch.c, 1 );
  endspecify
endmodule
```

25.7 Tasks and functions in interfaces

Subroutines (tasks and functions) can be defined within an interface, or they can be defined within one or more of the modules connected. This allows a more abstract level of modeling. For example, “read” and “write” can be defined as tasks, without reference to any wires, and the master module can merely call these tasks. In a **modport**, these tasks are declared as **import** tasks.

A function prototype specifies the types and directions of the arguments and the return value of a function that is defined elsewhere. Similarly, a task prototype specifies the types and directions of the arguments of a task that is defined elsewhere. In a **modport**, the **import** and **export** constructs can either use subroutine prototypes or use just the identifiers. The only exceptions are when a **modport** is used to import a subroutine from another module and when default argument values or argument binding by name is used, in which cases a full prototype shall be used.

The number and types of arguments in a prototype shall match the argument types in the subroutine declaration. The rules for type matching are described in [6.22.1](#). If a default argument value is needed in a subroutine call, it shall be specified in the prototype. If an argument has default values specified in both the prototype and the declaration, the specified values need not be the same, but the default value used shall be the one specified in the prototype. Formal argument names in a prototype shall be optional unless default argument values or argument binding by name is used or additional unpacked dimensions are declared. The formal argument names in the prototype shall be the same as the formal argument names in a declaration.

If a module is connected to a **modport** containing an exported subroutine and the module does not define that subroutine, then an elaboration error shall occur. Similarly, if the **modport** contains an exported subroutine prototype and the subroutine defined in the module does not exactly match that prototype, then an elaboration error shall occur.

If the subroutines are defined in a module using a hierarchical name, they shall also be declared as **extern** in the interface or as **export** in a **modport**.

Tasks (not functions) can be defined in a module that is instantiated twice, e.g., two memories driven from the same central processing unit (CPU). Such multiple task definitions are allowed by an **extern forkjoin** declaration in the interface.

25.7.1 Example of using tasks in interface

```

interface simple_bus (input logic clk); // Define the interface
  logic req, gnt;
  logic [7:0] addr, data;
  logic [1:0] mode;
  logic start, rdy;

  task masterRead(input logic [7:0] raddr); // masterRead method
    // ...
  endtask: masterRead

  task slaveRead; // slaveRead method
    // ...
  endtask: slaveRead

endinterface: simple_bus

module memMod(interface a); // Uses any interface
  logic avail;

  always @(posedge a.clk) // the clk signal from the interface
    a.gnt <= a.req & avail // the gnt and req signals in the interface

  always @(a.start)
    a.slaveRead;
endmodule

module cpuMod(interface b);
  enum {read, write} instr;
  logic [7:0] raddr;

  always @(posedge b.clk)
    if (instr == read)
      b.masterRead(raddr); // call the Interface method
    ...
endmodule

module top;
  logic clk = 0;

  simple_bus sb_intf(clk); // Instantiate the interface

  memMod mem(sb_intf);
  cpuMod cpu(sb_intf);
endmodule

```

25.7.2 Example of using tasks in modports

This interface example shows how to use modports to control signal directions and task access in a full read/write interface.

```

interface simple_bus (input logic clk); // Define the interface
  logic req, gnt;
  logic [7:0] addr, data;
  logic [1:0] mode;
  logic start, rdy;

```

```
    modport slave (input req, addr, mode, start, clk,
                  output gnt, rdy,
                  ref data,
                  import slaveRead,
                      slaveWrite);
        // import into module that uses the modport

    modport master(input gnt, rdy, clk,
                  output req, addr, mode, start,
                  ref data,
                  import masterRead,
                      masterWrite);
        // import into module that uses the modport

    task masterRead(input logic [7:0] raddr); // masterRead method
        // ...
    endtask

    task slaveRead; // slaveRead method
        // ...
    endtask

    task masterWrite(input logic [7:0] waddr);
        //...
    endtask

    task slaveWrite;
        //...
    endtask

endinterface: simple_bus

module memMod(interface a); // Uses just the interface
    logic avail;

    always @(posedge a.clk) // the clk signal from the interface
        a.gnt <= a.req & avail; // the gnt and req signals in the interface

    always @(a.start)
        if (a.mode[0] == 1'b0)
            a.slaveRead;
        else
            a.slaveWrite;
endmodule

module cpuMod(interface b);
    enum {read, write} instr = $rand();
    logic [7:0] raddr = $rand();

    always @(posedge b.clk)
        if (instr == read)
            b.masterRead(raddr); // call the Interface method
        // ...
        else
            b.masterWrite(raddr);
endmodule

module omniMod( interface b);
    //...
```

```

endmodule: omniMod

module top;
  logic clk = 0;

  simple_bus sb_intf(clk); // Instantiate the interface

  memMod mem(sb_intf.slave); // only has access to the slave tasks
  cpuMod cpu(sb_intf.master); // only has access to the master tasks
  omniMod omni(sb_intf); // has access to all master and slave tasks
endmodule

```

25.7.3 Example of exporting tasks and functions

This interface example shows how to define tasks in one module and call them in another, using modports to control task access.

```

interface simple_bus (input logic clk); // Define the interface
  logic req, gnt;
  logic [7:0] addr, data;
  logic [1:0] mode;
  logic start, rdy;

  modport slave(input req, addr, mode, start, clk,
               output gnt, rdy,
               ref data,
               export Read,
               Write);
  // export from module that uses the modport

  modport master(input gnt, rdy, clk,
                output req, addr, mode, start,
                ref data,
                import task Read(input logic [7:0] raddr),
                task Write(input logic [7:0] waddr));
  // import requires the full task prototype

endinterface: simple_bus

module memMod(interface a); // Uses just the interface keyword
  logic avail;

  task a.Read; // Read method
  avail = 0;
  ...
  avail = 1;
endtask

  task a.Write;
  avail = 0;
  ...
  avail = 1;
endtask
endmodule

module cpuMod(interface b);
  enum {read, write} instr;
  logic [7:0] raddr;

```



```

    always @(posedge b.clk)
        if (instr == read)
            b.Read(raddr); // call the slave method via the interface
            ...
        else
            b.Write(raddr);
endmodule

module top;
    logic clk = 0;

    simple_bus sb_intf(clk); // Instantiate the interface

    memMod mem(sb_intf.slave); // exports the Read and Write tasks
    cpuMod cpu(sb_intf.master); // imports the Read and Write tasks
endmodule

```

25.7.4 Example of multiple task exports

It is normally an error for more than one module to export the same task name. However, several instances of the same modport type can be connected to an interface, such as memory modules in the previous example. So that these can still export their read and write tasks, the tasks shall be declared in the interface using the **extern forkjoin** keywords.

The call to **extern forkjoin task** `countslaves ()`; in the example below behaves as follows:

```

fork
    top.mem1.a.countslaves;
    top.mem2.a.countslaves;
join

```

For a read task, only one module should actively respond to the task call, e.g., the one containing the appropriate address. The tasks in the other modules should return with no effect. Only then should the active task write to the result variables.

Unlike tasks, multiple export of functions is not allowed because they always write to the result.

The effect of a **disable** on an extern forkjoin task is as follows:

- If the task is referenced via the interface instance, all task calls shall be disabled.
- If the task is referenced via the module instance, only the task call to that module instance shall be disabled.
- If an interface contains an extern forkjoin task and no module connected to that interface defines the task, then any call to that task shall report a run-time error and return immediately with no effect.

This interface example shows how to define tasks in more than one module and call them in another using **extern forkjoin**. The multiple task export mechanism can also be used to count the instances of a particular modport that are connected to each interface instance.

```

interface simple_bus (input logic clk); // Define the interface
    logic req, gnt;
    logic [7:0] addr, data;
    logic [1:0] mode;
    logic start, rdy;
    int slaves = 0;
endinterface

```

```

// tasks executed concurrently as a fork-join block
extern forkjoin task countSlaves();
extern forkjoin task Read (input logic [7:0] raddr);
extern forkjoin task Write (input logic [7:0] waddr);

modport slave (input req,addr, mode, start, clk,
              output gnt, rdy,
              ref data, slaves,
              export Read, Write, countSlaves);
    // export from module that uses the modport

modport master ( input gnt, rdy, clk,
                output req, addr, mode, start,
                ref data,
                import task Read(input logic [7:0] raddr),
                task Write(input logic [7:0] waddr));
    // import requires the full task prototype

initial begin
    slaves = 0;
    countSlaves;
    $display ("number of slaves = %d", slaves);
end

endinterface: simple_bus

module memMod #(parameter int minaddr=0, maxaddr=0;) (interface a);
    logic avail = 1;
    logic [7:0] mem[255:0];

    task a.countSlaves();
        a.slaves++;
    endtask

    task a.Read(input logic [7:0] raddr); // Read method
        if (raddr >= minaddr && raddr <= maxaddr) begin
            avail = 0;
            #10 a.data = mem[raddr];
            avail = 1;
        end
    endtask

    task a.Write(input logic [7:0] waddr); // Write method
        if (waddr >= minaddr && waddr <= maxaddr) begin
            avail = 0;
            #10 mem[waddr] = a.data;
            avail = 1;
        end
    endtask
endmodule

module cpuMod(interface b);
    typedef enum {read, write} instr;
    instr inst;
    logic [7:0] raddr;
    integer seed;

    always @(posedge b.clk) begin

```

```

    inst = instr'($dist_uniform(seed, 0, 1));
    raddr = $dist_uniform(seed, 0, 3);
    if (inst == read) begin
        $display("%t begin read %h @ %h", $time, b.data, raddr);
        callr:b.Read(raddr);
        $display("%t end read %h @ %h", $time, b.data, raddr);
    end
    else begin
        $display("%t begin write %h @ %h", $time, b.data, raddr);
        b.data = raddr;
        callw:b.Write(raddr);
        $display("%t end write %h @ %h", $time, b.data, raddr);
    end
end
endmodule

module top;
    logic clk = 0;

    function void interrupt();
        disable mem1.a.Read; // task via module instance
        disable sb_intf.Write; // task via interface instance
        if (mem1.avail == 0) $display ("mem1 was interrupted");
        if (mem2.avail == 0) $display ("mem2 was interrupted");
    endfunction

    always #5 clk++;

    initial begin
        #28 interrupt();
        #10 interrupt();
        #100 $finish;
    end

    simple_bus sb_intf(clk);

    memMod #(0, 127) mem1(sb_intf.slave);
    memMod #(128, 255) mem2(sb_intf.slave);
    cpuMod cpu(sb_intf.master);
endmodule

```

25.8 Parameterized interfaces

Interface definitions can take advantage of parameters and parameter redefinition, in the same manner as module definitions. The following example shows how to use parameters in interface definitions.

```

interface simple_bus #(AWIDTH = 8, DWIDTH = 8)
    (input logic clk); // Define the interface

    logic req, gnt;
    logic [AWIDTH-1:0] addr;
    logic [DWIDTH-1:0] data;
    logic [1:0] mode;
    logic start, rdy;

    modport slave( input req, addr, mode, start, clk,
                  output gnt, rdy,
                  ref data,

```

```

        import task slaveRead,
               task slaveWrite);
    // import into module that uses the modport

modport master(input gnt, rdy, clk,
               output req, addr, mode, start,
               ref data,
               import task masterRead(input logic [AWIDTH-1:0] raddr),
               task masterWrite(input logic [AWIDTH-1:0] waddr));
    // import requires the full task prototype

task masterRead(input logic [AWIDTH-1:0] raddr); // masterRead method
    ...
endtask

task slaveRead; // slaveRead method
    ...
endtask

task masterWrite(input logic [AWIDTH-1:0] waddr);
    ...
endtask

task slaveWrite;
    ...
endtask

endinterface: simple_bus

module memMod(interface a); // Uses just the interface keyword
    logic avail;

    always @(posedge a.clk) // the clk signal from the interface
        a.gnt <= a.req & avail; //the gnt and req signals in the interface

    always @(a.start)
        if (a.mode[0] == 1'b0)
            a.slaveRead;
        else
            a.slaveWrite;
endmodule

module cpuMod(interface b);
    enum {read, write} instr;
    logic [7:0] raddr;

    always @(posedge b.clk)
        if (instr == read)
            b.masterRead(raddr); // call the Interface method
            // ...
        else
            b.masterWrite(raddr);
endmodule

module top;

    logic clk = 0;

    simple_bus sb_intf(clk); // Instantiate default interface

```

```

simple_bus #(.DWIDTH(16)) wide_intf(clk); // Interface with 16-bit data

initial repeat(10) #10 clk++;

memMod mem(sb_intf.slave); // only has access to the slaveRead task
cpuMod cpu(sb_intf.master); // only has access to the masterRead task

memMod memW(wide_intf.slave); // 16-bit wide memory
cpuMod cpuW(wide_intf.master); // 16-bit wide cpu
endmodule

```

25.9 Virtual interfaces

Virtual interfaces provide a mechanism for separating abstract models and test programs from the actual signals that make up the design. A virtual interface allows the same subprogram to operate on different portions of a design and to dynamically control the set of signals associated with the subprogram. Instead of referring to the actual set of signals directly, users are able to manipulate a set of virtual signals. Changes to the underlying design do not require the code using virtual interfaces to be rewritten. By abstracting the connectivity and functionality of a set of blocks, virtual interfaces promote code reuse.

A virtual interface is a variable that represents an interface instance. The syntax to declare a virtual interface variable is given in [Syntax 25-3](#).

```

virtual_interface_declaration ::= // from A.2.9
    virtual [ interface ] interface_identifier [ parameter_value_assignment ] [ . modport_identifier ]
    list_of_virtual_interface_decl ;

list_of_virtual_interface_decl ::= // from A.2.3
    variable_identifier [ = interface_instance_identifier ]
    { , variable_identifier [ = interface_instance_identifier ] }

data_declaration9 ::= // from A.2.1.3
    ...
    | virtual_interface_declaration

data_type ::= // from A.2.2.1
    ...
    | virtual [ interface ] interface_identifier

```

9) In a data_declaration that is not within a procedural context, it shall be illegal to use the **automatic** keyword. In a data_declaration, it shall be illegal to omit the explicit data_type before a list_of_variable_decl_assignments unless the **var** keyword is used.

Syntax 25-3—Virtual interface declaration syntax (excerpt from [Annex A](#))

Virtual interface variables may be passed as arguments to tasks, functions, or methods. A single virtual interface variable can thus represent different interface instances at different times throughout the simulation. A virtual interface shall be initialized before referencing a component of the virtual interface; it has the value **null** before it is initialized. Attempting to use a **null** virtual interface shall result in a fatal run-time error.

The type of an interface shall include actual parameters, default or overridden, used in the instantiation of an interface or the declaration of a virtual interface variable. The actual values and types of those parameters shall match for an interface and virtual interface to be of the same type and to be assignment compatible (see [6.22.3](#)). A virtual interface declaration may select a modport of an interface in which case the modport is

also part of its type. An interface instance or virtual interface with no modport selected may be assigned to a virtual interface with a modport selected.

Although an interface may contain hierarchical references to objects outside its body or ports that reference other interfaces, it shall be illegal to use an interface containing those references in the declaration of a virtual interface.

Only the following operations are directly allowed on virtual interface variables:

- Assignment (=) to the following:
 - Another virtual interface of the same type
 - An interface instance of the same type
 - The special constant **null**
- Equality (==) and inequality (!=) with the following:
 - Another virtual interface of the same type
 - An interface instance of the same type
 - The special constant **null**

Virtual interfaces shall not be used as ports, interface items, or as members of unions.

Once a virtual interface has been initialized, all the components of the underlying interface instance are directly available to the virtual interface via the dot notation. These components can only be used in procedural statements; they cannot be used in continuous assignments or sensitivity lists. In order for a net to be driven via a virtual interface, the interface itself must provide a procedural means to do so. This can be accomplished either via a **clocking** block or by including a driver that is updated by a continuous assignment from a variable within the interface.

Virtual interfaces can be declared as class properties, which can be initialized procedurally or by an argument to **new()**. This allows the same virtual interface to be used in different classes. The following example shows how the same transactor class can be used to interact with various different devices:

```

interface SBus;                                // A Simple bus interface
    logic req, grant;
    logic [7:0] addr, data;
endinterface

class SBusTransactor;                          // SBus transactor class
    virtual SBus bus;                          // virtual interface of type SBus

    function new( virtual SBus s );
        bus = s;                               // initialize the virtual interface
    endfunction

    task request();                            // request the bus
        bus.req <= 1'b1;
    endtask

    task wait_for_bus();                       // wait for the bus to be granted
        @(posedge bus.grant);
    endtask
endclass

module devA( SBus s ) ... endmodule          // devices that use SBus
module devB( SBus s ) ... endmodule

```

```

module top;

    SBus s[1:4] ();                                // instantiate 4 interfaces

    devA a1( s[1] );                               // instantiate 4 devices
    devB b1( s[2] );
    devA a2( s[3] );
    devB b2( s[4] );

    initial begin
        SBusTransactor t[1:4];                    // create 4 bus-transactors and bind
        t[1] = new( s[1] );
        t[2] = new( s[2] );
        t[3] = new( s[3] );
        t[4] = new( s[4] );
        // test t[1:4]
    end
endmodule

```

In the preceding example, the transaction class `SbusTransactor` is a simple reusable component. It is written without any global or hierarchical references and is unaware of the particular device with which it will interact. Nevertheless, the class can interact with any number of devices (four in the example) that adhere to the interface's protocol.

An interface instance, or virtual interface, with no modport selected may be assigned to a virtual interface with a modport selected.

```

interface PBus #(parameter WIDTH=8); // A parameterized bus interface
    logic req, grant;
    logic [WIDTH-1:0] addr, data;
    modport phy(input addr, ref data);
endinterface
module top;
    PBus #(16) p16();
    PBus #(32) p32();
    virtual Pbus V8; // legal declaration, but no legal assignments
    virtual Pbus #(35) V35; // legal declaration, but no legal assignments
    virtual Pbus #(16) v16;
    virtual Pbus #(16).phy v16_phy;
    virtual Pbus #(32) v32;
    virtual Pbus #(32).phy v32_phy;
    initial begin
        v16 = p16; // legal - parameter values match
        v32 = p32; // legal - parameter values match
        v16 = p32; // illegal - parameter values don't match
        v16 = v32; // illegal - parameter values don't match
        v16_phy = v16; // legal assignment from no selected modport to
        // selected modport
        v16 = v16_phy; // illegal assignment from selected modport to
        // no selected modport
        v32_phy = p32; // legal assignment from no selected modport to
        // selected modport
        v32 = p32.phy; // illegal assignment from selected modport to
        // no selected modport
    end
endmodule

```

25.9.1 Virtual interfaces and clocking blocks

Interfaces and **clocking** blocks can be combined to represent the interconnect between synchronous blocks. Moreover, because **clocking** blocks provide a procedural mechanism to assign values to both nets and variables, they are ideally suited to be used by virtual interfaces. For example:

```

interface SyncBus( input logic clk );
    wire a, b, c;

    clocking sb @(posedge clk);
        input a;
        output b;
        inout c;
    endclocking

endinterface

typedef virtual SyncBus VI;           // A virtual interface type

task do_it( VI v );                   // handles any SyncBus via clocking sb
    if( v.sb.a == 1 )
        v.sb.b <= 0;
    else
        v.sb.c <= ##1 1;
endtask

```

In the preceding example, interface `SyncBus` includes a **clocking** block, which is used by task `do_it` to provide synchronous access to the interface's signals: `a`, `b`, and `c`. A change to the storage type of the interface signals (from net to variable and vice versa) requires no changes to the task. The interfaces can be instantiated as follows:

```

module top;
    logic clk;

    SyncBus b1( clk );
    SyncBus b2( clk );

    initial begin
        VI v[2] = '{ b1, b2 };

        repeat( 20 )
            do_it( v[ $urandom_range( 0, 1 ) ] );
    end
endmodule

```

The top module above shows how a virtual interface can be used to randomly select among a set of interfaces to be manipulated, in this case by the `do_it` task.

25.9.2 Virtual interface modports and clocking blocks

As shown in the example above, once a virtual interface is declared, its **clocking** block can be referenced using dot notation. However, this only works for interfaces with no modports. Typically, a DUT and its testbench exhibit modport direction. This common case can be handled by including the clocking in the corresponding modport as described in [25.5.5](#).

The following example shows how modports used in conjunction with virtual interfaces facilitate the creation of abstract synchronous models.

```

interface A_Bus( input logic clk );
  wire req, gnt;
  wire [7:0] addr, data;

  clocking sb @(posedge clk);
    input gnt;
    output req, addr;
    inout data;

    property p1; req ##[1:3] gnt; endproperty
endclocking

  modport DUT ( input clk, req, addr,    // Device under test modport
               output gnt,
               inout data );

  modport STB ( clocking sb );          // synchronous testbench modport

  modport TB ( input gnt,                // asynchronous testbench modport
              output req, addr,
              inout data );
endinterface

```

The above interface A_Bus can then be instantiated as follows:

```

module dev1(A_Bus.DUT b);                // Some device: Part of the design
  ...
endmodule

module dev2(A_Bus.DUT b);                // Some device: Part of the design
  ...
endmodule

program T (A_Bus.STB b1, A_Bus.STB b2 ); // Testbench: 2 synchronous ports
  ...
endprogram

module top;
  logic clk;

  A_Bus b1( clk );
  A_Bus b2( clk );

  dev1 d1( b1 );
  dev2 d2( b2 );

  T tb( b1, b2 );
endmodule

```

And, within the testbench program, the virtual interface can refer directly to the **clocking** block.

```

program T (A_Bus.STB b1, A_Bus.STB b2 ); // Testbench: 2 synchronous ports

  typedef virtual A_Bus.STB SYNCTB;

  task request( SYNCTB s );
    s.sb.req <= 1;
  endtask

```

```

endtask

task wait_grant( SYNCTB s );
    wait( s.sb.gnt == 1 );
endtask

task drive(SYNCTB s, logic [7:0] adr, data );
    if( s.sb.gnt == 0 ) begin
        request(s);                // acquire bus if needed
        wait_grant(s);
    end
    s.sb.addr = adr;
    s.sb.data = data;
    repeat(2) @s.sb;
    s.sb.req = 0;                    //release bus
endtask

assert property (b1.sb.p1);        // assert property from within program

initial begin
    drive( b1, $random, $random );
    drive( b2, $random, $random );
end
endprogram

```

The example above shows how the **clocking** block is referenced via the virtual interface by the tasks within the program block.

25.10 Access to interface objects

Access to objects declared in an interface shall be available by hierarchical name reference, regardless of whether the interface is also accessed through a port connection or through a virtual interface, and regardless of the existence of any declared modports in that interface. A modport may be used to restrict access to objects declared in an interface that are referenced through a port connection or virtual interface by explicitly listing the accessible objects in the modport. However, objects that are not permissible to be listed in a modport shall remain accessible. For example:

```

interface ebus_i;
    integer I;                // reference to I not allowed through modport mp
    typedef enum {Y,N} choice;
    choice Q;
    localparam True = 1;
    modport mp(input Q);
endinterface

module Top;
    ebus_i ebus ();
    sub s1 (ebus.mp);
endmodule

module sub(interface.mp i);
    typedef i.choice yes_no;  // import type from interface
    yes_no P;
    assign P = i.Q;          // refer to Q with a port reference
    initial
        Top.ebus.Q = i.True; // refer to Q with a hierarchical reference
    initial

```

```
Top.ebus.I = 0;           // referring to i.I would not be legal because
                           // is not in modport mp
endmodule
```

26. Packages

26.1 General

This clause describes the following:

- Package declarations
- Referencing data within packages
- Package search order rules
- Exporting imported names from packages
- The `std` built-in package

26.2 Package declarations

SystemVerilog packages provide an additional mechanism for sharing parameters, data, type, task, function, sequence, property, and checker declarations among multiple SystemVerilog modules, interfaces, programs, and checkers.

Packages are explicitly named scopes appearing at the outermost level of the source text (at the same level as top-level modules and primitives). Types, nets, variables, tasks, functions, sequences, properties, and checkers may be declared within a package. Such declarations may be referenced within modules, interfaces, programs, checkers, and other packages by either `import` or fully resolved name.

Packages may contain processes inside checkers only. Therefore, net declarations with implicit continuous assignments are not allowed.

```

package_declaration ::=                                     // from A.1.2
    { attribute_instance } package [ lifetime ] package_identifier ;
    [ timeunits_declaration ] { { attribute_instance } package_item }
    endpackage [ : package_identifier ]

package_item ::=                                         // from A.1.11
    package_or_generate_item_declaration
    | anonymous_program
    | package_export_declaration
    | timeunits_declaration3

package_or_generate_item_declaration ::=
    net_declaration
    | data_declaration
    | task_declaration
    | function_declaration
    | checker_declaration
    | dpi_import_export
    | extern_constraint_declaration
    | class_declaration
    | class_constructor_declaration
    | local_parameter_declaration ;
    | parameter_declaration ;
    | covergroup_declaration
    | overload_declaration
    | assertion_item_declaration
    | ;

```

```
anonymous_program ::= program ; { anonymous_program_item } endprogram
anonymous_program_item ::=
    task_declaration
  | function_declaration
  | class_declaration
  | covergroup_declaration
  | class_constructor_declaration
  | ;
```

- 3) A `timeunits_declaration` shall be legal as a `non_port_module_item`, `non_port_interface_item`, `non_port_program_item`, or `package_item` only if it repeats and matches a previous `timeunits_declaration` within the same time scope.

Syntax 26-1—Package declaration syntax (excerpt from [Annex A](#))

The **package** declaration creates a scope that contains declarations intended to be shared among one or more compilation units, modules, interfaces, or programs. Items within packages are generally type definitions, tasks, and functions. Items within packages shall not have hierarchical references to identifiers except those created within the package or made visible by import of another package. A package shall not refer to items defined in the compilation unit scope. (See [3.12.1](#).) It is also possible to populate packages with parameters, variables, and nets. This may be useful for global items that are not conveniently passed down through the hierarchy. Variable declaration assignments within the package shall occur before any initial or always procedures are started, in the same way as variables declared in a compilation unit or module.

The following is an example of a package:

```
package ComplexPkg;
  typedef struct {
    shortreal i, r;
  } Complex;

  function Complex add(Complex a, b);
    add.r = a.r + b.r;
    add.i = a.i + b.i;
  endfunction

  function Complex mul(Complex a, b);
    mul.r = (a.r * b.r) - (a.i * b.i);
    mul.i = (a.r * b.i) + (a.i * b.r);
  endfunction
endpackage : ComplexPkg
```

26.3 Referencing data in packages

The compilation of a package shall precede the compilation of scopes in which the package is imported.

One way to use declarations made in a package is to reference them using the class scope resolution operator `::`.

```
ComplexPkg::Complex cout = ComplexPkg::mul(a, b);
```

An alternate method for utilizing package declarations is via the **import** declaration (see [Syntax 26-2](#)).

```

data_declaration ::= //from A.2.1.3
...
| package_import_declaration10
...
package_import_declaration ::=
    import package_import_item { , package_import_item } ;
package_import_item ::=
    package_identifier :: identifier
| package_identifier :: *

```

¹⁰⁾ It shall be illegal to have an import statement directly within a class scope.

Syntax 26-2—Package import syntax (excerpt from [Annex A](#))

The **import** declaration provides direct visibility of identifiers within packages. It allows identifiers declared within packages to be visible within the current scope without a package name qualifier. Two forms of the **import** declaration are provided: explicit import and wildcard import. Explicit import allows control over precisely which symbols are imported:

```

import ComplexPkg::Complex;
import ComplexPkg::add;

```

An explicit import only imports the symbols specifically referenced by the import.

In the example below, the import of the enumeration type `teeth_t` does not import the enumeration literals `ORIGINAL` and `FALSE`. In order to refer to the enumeration literal `FALSE` from package `q`, either add `import q::FALSE` or use a full package reference as in `teeth = q::FALSE;`.

```

package p;
    typedef enum { FALSE, TRUE } bool_t;
endpackage

package q;
    typedef enum { ORIGINAL, FALSE } teeth_t;
endpackage

module top1 ;
    import p::*;
    import q::teeth_t;

    teeth_t myteeth;

    initial begin
        myteeth = q:: FALSE; // OK:
        myteeth = FALSE;    // ERROR: Direct reference to FALSE refers to the
    end                                // FALSE enumeration literal imported from p
endmodule

module top2 ;
    import p::*;
    import q::teeth_t, q::ORIGINAL, q::FALSE;

    teeth_t myteeth;

```

```
initial begin
    myteeth = FALSE; // OK: Direct reference to FALSE refers to the
end // FALSE enumeration literal imported from q
endmodule
```

An explicit import shall be illegal if the imported identifier is declared in the same scope or explicitly imported from another package. Importing an identifier from the same package multiple times is allowed.

A wildcard import allows all identifiers declared within a package to be imported provided the identifier is not otherwise defined in the importing scope: A wildcard import is of the following form:

```
import ComplexPkg::*;
```

An identifier is *potentially locally visible* at some point within a scope if there is a wildcard import of a package before that point within the current scope and the package contains a declaration of that identifier.

An identifier is *locally visible* at some point within a scope if

- a) The identifier denotes a nested scope within the current scope, or
- b) The identifier is declared as an identifier prior to that point within the current scope, or
- c) The identifier is visible from an explicit import prior to that point within the current scope

A potentially locally visible identifier from a wildcard import may become locally visible if the resolution of a reference to an identifier finds no other matching locally visible identifiers.

For a reference to an identifier other than function or task call, the locally visible identifiers defined at the point of the reference in the current scope shall be searched. If the reference is a function or task call, all of the locally visible identifiers to the end of the current scope shall be searched. If a match is found, the reference shall be bound to that locally visible identifier.

If no locally visible identifiers match, then the potentially locally visible identifiers defined prior to the point of the reference in the current scope shall be searched. If a match is found, that identifier from the package shall be imported into the current scope, becoming a locally visible identifier within the current scope, and the reference shall be bound to that identifier.

If the reference is not bound within the current scope, the next outer lexical scope shall be searched; first from among the locally visible identifiers in that scope and then from among the potentially locally visible identifiers defined prior to the point of the reference. If a match is found among the potentially locally visible identifiers, that identifier from the package shall be imported into the outer scope, becoming a locally visible identifier within the outer scope.

If a wildcard imported symbol is made locally visible in a scope, any later locally visible declaration of the same name in that scope shall be illegal.

The search algorithm shall be repeated for each outer lexical scope until an identifier is found that matches the reference or there are no more outer lexical scopes, the compilation unit scope being the final scope searched. For a reference to an identifier other than function or task call, it shall be illegal if no identifier can be found that matches the reference. If the reference is a function or task call, the search continues using upwards hierarchical identifier resolution (see [23.8.1](#)).

It shall be illegal if the wildcard import of more than one package within the same scope defines the same potentially locally visible identifier and a search for a reference matches that identifier.

Example 1:

```

package p;
  int x;
endpackage

module top;
  import p::*;           // line 1

  if (1) begin : b
    initial x = 1;       // line 2
    int x;               // line 3
    initial x = 1;       // line 4
  end
  int x;                 // line 5
endmodule

```

The reference in line 2 causes the potentially locally visible `x` from wildcard import `p::*` (`p::x`) to become locally visible in scope `top` and line 2 initializes `p::x`. Line 4 initializes `top.b.x`. Line 5 is illegal since it is a local declaration in scope `top`, which conflicts with the name `x` imported from `p`, which had already become a locally visible declaration.

Example 2:

```

package p;
  int x;
endpackage

package p2;
  int x;
endpackage

module top;
  import p::*;           // line 1
  if (1) begin : b
    initial x = 1;       // line 2
    import p2::*;        // line 3
  end
endmodule

```

Line 2 causes the import of `p::x` in scope `top` because the wildcard import `p::*` is in the outer scope `top` and precedes the occurrence of `x`. The declaration `x` from package `p` becomes locally visible in scope `top`.

Example 3:

```

package p;
  function int f();
    return 1;
  endfunction
endpackage

module top;
  int x;
  if (1) begin : b
    initial x = f();     // line 2
    import p::*;        // line 3
  end

```



```

    function int f();
        return 1;
    endfunction
endmodule

```

`f()` on line 2 binds to `top.f` and not to `p::f` since the import is after the function call reference.

Example 4:

```

package p;
    function int f();
        return 1;
    endfunction
endpackage

package p2;
    function int f();
        return 1;
    endfunction
endpackage

module top;
    import p::*;
    int x;
    if (1) begin : b
        initial x = f();    // line 1
    end
    import p2::*;
endmodule

```

Since `f` is not found in scope `b`, the rules require inspection of all wildcard imports in the parent scope. There are two wildcard imports, but only the wildcard import `p::*` that is lexically preceding the occurrence of `f()` is considered. In this case, `f` binds to `p::f`.

The effect of importing an identifier into a scope makes that identifier visible without requiring access using the scope resolution operator. Importing does not copy the declaration of that identifier into the importing scope. The imported identifier shall not be visible outside that importing scope by hierarchical reference into that scope or by interface port reference into that scope.

It shall be illegal to have an import statement directly within a class scope.

26.4 Using packages in module headers

Package items can be referenced in module, interface or program parameter and port declarations by importing the package as part of the header to the module, interface, or program declaration. The syntax is shown in [Syntax 26-3](#).

```

module_nonansi_header ::= //from A.1.2
    { attribute_instance } module_keyword [ lifetime ] module_identifier
    { package_import_declaration } [ parameter_port_list ] list_of_ports ;
module_ansi_header ::=
    { attribute_instance } module_keyword [ lifetime ] module_identifier
    { package_import_declaration }1 [ parameter_port_list ] [ list_of_port_declarations ] ;

```

```

interface_nonansi_header ::=
  { attribute_instance } interface [ lifetime ] interface_identifier
  { package_import_declaration } [ parameter_port_list ] list_of_ports ;
interface_ansi_header ::=
  { attribute_instance } interface [ lifetime ] interface_identifier
  { package_import_declaration }1 [ parameter_port_list ] [ list_of_port_declarations ] ;
program_nonansi_header ::=
  { attribute_instance } program [ lifetime ] program_identifier
  { package_import_declaration } [ parameter_port_list ] list_of_ports ;
program_ansi_header ::=
  { attribute_instance } program [ lifetime ] program_identifier
  { package_import_declaration }1 [ parameter_port_list ] [ list_of_port_declarations ] ;

```

- 1) A package_import_declaration in a module_ansi_header, interface_ansi_header, or program_ansi_header shall be followed by a parameter_port_list or list_of_port_declarations, or both.

Syntax 26-3—Package import in header syntax (excerpt from [Annex A](#))

Package items that are imported as part of a module, interface or program header are visible throughout the module, interface, or program, including in parameter and port declarations.

For example:

```

package A;
  typedef struct {
    bit [ 7:0] opcode;
    bit [23:0] addr;
  } instruction_t;
endpackage: A

package B;
  typedef enum bit {FALSE, TRUE} boolean_t;
endpackage: B

module M import A::instruction_t, B::*;
  #(WIDTH = 32)
  (input [WIDTH-1:0] data,
   input instruction_t a,
   output [WIDTH-1:0] result,
   output boolean_t OK
  );
  ...
endmodule: M

```

26.5 Search order rules

[Table 26-1](#) describes the search order rules for the declarations imported from a package. For the purposes of the discussion that follows, consider the following package declarations:

```

package p;
  typedef enum { FALSE, TRUE } BOOL;
  const BOOL c = FALSE;
endpackage

```

```
package q;
  const int c = 0;
endpackage
```

Table 26-1—Scoping rules for package importation

Example	Description	In a scope containing a local declaration of <i>c</i>	In a scope not containing a local declaration of <i>c</i>	In a scope containing an explicit import of <i>c</i> (import <i>q</i> :: <i>c</i>)	In a scope containing a wildcard import of <i>c</i> (import <i>q</i> ::*)
<pre>u = p::c; y = p::TRUE;</pre>	A qualified package identifier is visible in any scope (without the need for an import clause).	<p>OK</p> <p>Direct reference to <i>c</i> refers to the locally declared <i>c</i>.</p> <p><i>p</i>::<i>c</i> refers to the <i>c</i> in package <i>p</i>.</p>	<p>OK</p> <p>Direct reference to <i>c</i> is illegal because it is undefined.</p> <p><i>p</i>::<i>c</i> refers to the <i>c</i> in package <i>p</i>.</p>	<p>OK</p> <p>Direct reference to <i>c</i> refers to the <i>c</i> imported from <i>q</i>.</p> <p><i>p</i>::<i>c</i> refers to the <i>c</i> in package <i>p</i>.</p>	<p>OK</p> <p>Direct reference to <i>c</i> refers to the <i>c</i> imported from <i>q</i>.</p> <p><i>p</i>::<i>c</i> refers to the <i>c</i> in package <i>p</i>.</p>
<pre>import p::*; . . . y = FALSE;</pre>	<p>All declarations inside package <i>p</i> become potentially directly visible in the importing scope:</p> <ul style="list-style-type: none"> – <i>c</i> – <i>BOOL</i> – <i>FALSE</i> – <i>TRUE</i> 	<p>OK</p> <p>Direct reference to <i>c</i> refers to the locally declared <i>c</i>.</p> <p>Direct reference to other identifiers (e.g., <i>FALSE</i>) refers to those implicitly imported from package <i>p</i>.</p>	<p>OK</p> <p>Direct reference to <i>c</i> refers to the <i>c</i> imported from package <i>p</i>.</p>	<p>OK</p> <p>Direct reference to <i>c</i> refers to the <i>c</i> imported from package <i>q</i>.</p>	<p>OK / ERROR</p> <p><i>c</i> is undefined in the importing scope. Thus, a direct reference to <i>c</i> is illegal and results in an error.</p> <p>The import clause is otherwise allowed.</p>
<pre>import p::c; . . . if(! c) ...</pre>	The imported identifier <i>c</i> becomes directly visible in the importing scope.	<p>ERROR</p> <p>It is illegal to import an identifier defined in the importing scope.</p>	<p>OK</p> <p>Direct reference to <i>c</i> refers to the <i>c</i> imported from package <i>p</i>.</p>	<p>ERROR</p> <p>It is illegal to import the same identifier from different packages.</p>	<p>OK / ERROR</p> <p>The import of <i>p</i>::<i>c</i> makes any prior reference to <i>c</i> illegal.</p> <p>Otherwise, direct reference to <i>c</i> refers to the <i>c</i> imported from package <i>p</i>.</p>

When using a wildcard import, a reference to an undefined identifier that is declared within the package causes that identifier to be imported into the scope of the import statement. However, an error results if the same identifier is later declared or explicitly imported in the same scope. This is shown in the following example:

```
module m;
  import q::*;
```

```

wire    a = c; // This statement forces the import of q::c;
import  p::c; // The conflict with q::c and p::c creates an error.
endmodule

```

26.6 Exporting imported names from packages

By default, declarations imported into a package are not visible by way of subsequent imports of that package. Package export declarations allow a package to specify that imported declarations are to be made visible in subsequent imports. A package export may precede a corresponding package import.

The syntax for package exports is shown in [Syntax 26-4](#).

```

package_export_declaration ::= // from A.2.1.3
    export *::* ;
    | export package_import_item { , package_import_item } ;

```

Syntax 26-4—Package export syntax (excerpt from [Annex A](#))

An export of the form `package_name::*` exports all declarations that were actually imported from `package_name` within the context of the exporting package. All names from `package_name`, whether imported directly or through wildcard imports, are made available. Symbols that are candidates for import but not actually imported are not made available. The special wildcard export form, `export *::*`, exports all imported declarations from all packages from which imports occur.

An export of the form `package_name::name` makes the given declaration available. It shall be an error if the given declaration is not a candidate for import or if the declaration is not actually imported in the package. The declaration being exported shall be imported from the same `package_name` used in the export. If the declaration is an unreferenced candidate for import, the export shall be considered to be a reference and shall import the declaration into the package following the same rules as for a direct import of the name.

An import of a declaration made visible through an export is equivalent to an import of the original declaration. Thus direct or wildcard import of a declaration by way of multiple exported paths does not cause conflicts.

It is valid to specify multiple exports that export the same actual declaration.

Examples:

```

package p1;
    int x, y;
endpackage

package p2;
    import p1::x;
    export p1::*; // exports p1::x as the name "x";
                // p1::x and p2::x are the same declaration
endpackage

package p3;
    import p1::*;
    import p2::*;
    export p2::*;

```

```

    int q = x;

    // p1::x and q are made available from p3. Although p1::y
    // is a candidate for import, it is not actually imported
    // since it is not referenced. Since p1::y is not imported,
    // it is not made available by the export.
endpackage

package p4;
  import p1::*;
  export p1::*;
  int y = x;           // y is available as a direct declaration;
                      // p1::x is made available by the export
endpackage

package p5;
  import p4::*;
  import p1::*;
  export p1::x;
  export p4::x;       // p4::x refers to the same declaration
                      // as p1::x so this is legal.
endpackage

package p6;
  import p1::*;
  export p1::x;
  int x;              // Error. export p1::x is considered to
                      // be a reference to "x" so a subsequent
                      // declaration of x is illegal.
endpackage

package p7;
  int y;
endpackage

package p8;
  export *::*;       // Exports both p7::y and p1::x.
  import p7::y;
  import p1::x;
endpackage

module top;
  import p2::*;
  import p4::*;
  int y = x;         // x is p1::x
endmodule

```

26.7 The std built-in package

SystemVerilog provides a built-in package that can contain system types (e.g., classes), variables, tasks, and functions. Users cannot insert additional declarations into the built-in package.

The contents of the standard built-in package are defined in [Annex G](#).

The built-in package is implicitly wildcard imported into the compilation-unit scope of every compilation unit (see [3.12.1](#)). Thus, declarations in the built-in package are directly available in any other scope (like system tasks and system functions) unless they are redefined by user code.

Declarations in the standard built-in package can also be directly referenced using the syntax shown in [Syntax 26-5](#).

```
built_in_data_type ::= [ std:: ] data_type_identifier  
built_in_function_call ::= [ std:: ] function_subroutine_call
```

Syntax 26-5—Std package import syntax (not in [Annex A](#))

The package name **std** followed by the class scope resolution operator **::** can be used to unambiguously access names in the built-in package. For example:

```
std::sys_task();    // unambiguously call the system provided sys_task
```

Unlike system tasks and system functions, tasks and functions in the built-in package need not be prefixed with a **\$** to avoid collisions with user-defined identifiers. This mechanism allows functional extensions to the language in a backward compatible manner, without the addition of new keywords or polluting local name spaces.

27. Generate constructs

27.1 General

This clause describes the following:

- Loop generate constructs
- Conditional generate constructs
- External names in unnamed generate constructs

27.2 Overview

Generate constructs are used to either conditionally or multiply instantiate generate blocks into a model. A *generate block* is a collection of one or more module items. A generate block may not contain port declarations, parameter declarations, specify blocks, or specparam declarations. All other module items, including other generate constructs, are allowed in a generate block. Generate constructs provide the ability for parameter values to affect the structure of the design. They also allow for modules with repetitive structure to be described more concisely, and they make recursive module instantiation possible.

27.3 Generate construct syntax

There are two kinds of generate constructs: loops and conditionals. *Loop generate constructs* allow a single generate block to be instantiated into a model multiple times. *Conditional generate constructs*, which include if-generate and case-generate constructs, instantiate at most one generate block from a set of alternative generate blocks. The term *generate scheme* refers to the method for determining which or how many generate blocks are instantiated. It includes the conditional expressions, case alternatives, and loop control statements that appear in a generate construct.

Generate schemes are evaluated during elaboration of the design. Although generate schemes use syntax that is similar to behavioral statements, it is important to recognize that they do not execute at simulation time. They are evaluated at elaboration time, and the result is determined before simulation begins. Therefore, all expressions in generate schemes shall be constant expressions, deterministic at elaboration time. For more details on elaboration, see [3.12](#).

The elaboration of a generate construct results in zero or more instances of a generate block. An instance of a generate block is similar in some ways to an instance of a module. It creates a new level of hierarchy. It brings the objects, behavioral constructs, and module instances within the block into existence. These constructs act the same as they would if they were in a module brought into existence with a module instantiation, except that object declarations from the enclosing scope can be referenced directly (see [23.9](#)). Names in instantiated named generate blocks can be referenced hierarchically as described in [23.6](#).

The keywords **generate** and **endgenerate** may be used in a module to define a *generate region*. A generate region is a textual span in the module description where generate constructs may appear. Use of generate regions is optional. There is no semantic difference in the module when a generate region is used. A parser may choose to recognize the generate region to produce different error messages for misused generate construct keywords. Generate regions do not nest, and they may only occur directly within a module. If the **generate** keyword is used, it shall be matched by an **endgenerate** keyword.

The syntax for generate constructs is given in [Syntax 27-1](#).

```

generate_region ::=
    generate { generate_item } endgenerate //from A.4.2
loop_generate_construct ::=
    for ( genvar_initialization ; genvar_expression ; genvar_iteration )
        generate_block
genvar_initialization ::=
    [ genvar ] genvar_identifier = constant_expression
genvar_iteration ::=
    genvar_identifier assignment_operator genvar_expression
    | inc_or_dec_operator genvar_identifier
    | genvar_identifier inc_or_dec_operator
conditional_generate_construct ::=
    if_generate_construct
    | case_generate_construct
if_generate_construct ::=
    if ( constant_expression ) generate_block [ else generate_block ]
case_generate_construct ::=
    case ( constant_expression ) case_generate_item { case_generate_item } endcase
case_generate_item ::=
    constant_expression { , constant_expression } : generate_block
    | default [ : ] generate_block
generate_block ::=
    generate_item
    | [ generate_block_identifier : ] begin [ : generate_block_identifier ]
        { generate_item }
    end [ : generate_block_identifier ]
generate_item26 ::=
    module_or_generate_item
    | interface_or_generate_item
    | checker_or_generate_item
module_or_generate_item ::=
    { attribute_instance } parameter_override
    | { attribute_instance } gate_instantiation
    | { attribute_instance } udp_instantiation
    | { attribute_instance } module_instantiation
    | { attribute_instance } module_common_item
module_or_generate_item_declaration ::=
    package_or_generate_item_declaration
    | genvar_declaration
    | clocking_declaration
    | default clocking clocking_identifier ;
module_common_item ::=
    module_or_generate_item_declaration
    | interface_instantiation
    | program_instantiation
    | assertion_item
    | bind_directive
    | continuous_assign
    | net_alias

```

```

| initial_construct
| final_construct
| always_construct
| loop_generate_construct
| conditional_generate_construct
interface_or_generate_item ::=                                //from A.1.6
  { attribute_instance } module_common_item
  | { attribute_instance } modport_declaration
  | { attribute_instance } extern_tf_declaration
package_or_generate_item_declaration ::=                    //from A.1.11
  net_declaration
  | data_declaration
  | task_declaration
  | function_declaration
  | checker_declaration
  | dpi_import_export
  | extern_constraint_declaration
  | class_declaration
  | class_constructor_declaration
  | local_parameter_declaration ;
  | parameter_declaration ;
  | covergroup_declaration
  | overload_declaration
  | assertion_item_declaration
  | ;

```

- 26) Within an interface_declaration, it shall only be legal for a generate_item to be an interface_or_generate_item. Within a module_declaration, except when also within an interface_declaration, it shall only be legal for a generate_item to be a module_or_generate_item. Within a checker_declaration, it shall only be legal for a generate_item to be a checker_or_generate_item.

Syntax 27-1—Syntax for generate constructs (excerpt from [Annex A](#))

27.4 Loop generate constructs

A loop generate construct permits a generate block to be instantiated multiple times using syntax that is similar to a for loop statement. The loop index variable shall be declared in a **genvar** declaration prior to its use in a loop generate scheme.

The **genvar** is used as an integer during elaboration to evaluate the generate loop and create instances of the generate block, but it does not exist at simulation time. A **genvar** shall not be referenced anywhere other than in a loop generate scheme.

Both the initialization and iteration assignments in the loop generate scheme shall assign to the same **genvar**. The initialization assignment shall not reference the loop index variable on the right-hand side.

Within the generate block of a loop generate construct, there is an implicit **localparam** declaration. This is an integer parameter that has the same name and type as the loop index variable, and its value within each instance of the generate block is the value of the index variable at the time the instance was elaborated. This parameter can be used anywhere within the generate block that a normal parameter with an integer value can be used. It can be referenced with a hierarchical name.

Because this implicit **localparam** has the same name as the **genvar**, any reference to this name inside the loop generate block will be a reference to the **localparam**, not to the **genvar**. As a consequence, it is not possible to have two nested loop generate constructs that use the same **genvar**.

Generate blocks in loop generate constructs can be named or unnamed, and they can consist of only one item, which need not be surrounded by **begin-end** keywords. Even if the **begin-end** keywords are absent, it is still a generate block, which, like all generate blocks, comprises a separate scope and a new level of hierarchy when it is instantiated.

If the generate block is named, it is a declaration of an array of generate block instances. The index values in this array are the values assumed by the **genvar** during elaboration. This can be a sparse array because the **genvar** values do not have to form a contiguous range of integers. The array is considered to be declared even if the loop generate scheme resulted in no instances of the generate block. If the generate block is not named, the declarations within it cannot be referenced using hierarchical names other than from within the hierarchy instantiated by the generate block itself.

It shall be an error if the name of a generate block instance array conflicts with any other declaration, including any other generate block instance array. It shall be an error if the loop generate scheme does not terminate. It shall be an error if a **genvar** value is repeated during the evaluation of the loop generate scheme. It shall be an **error** if any bit of the **genvar** is set to **x** or **z** during the evaluation of the loop generate scheme.

Example 1—Examples of legal and illegal generate loops

```

module mod_a;
  genvar i;

  // "generate", "endgenerate" keywords are not required

  for (i=0; i<5; i=i+1) begin:a
    for (i=0; i<5; i=i+1) begin:b
      ...                // error -- using "i" as loop index for
      ...                // two nested generate loops
    end
  end
endmodule

module mod_b;
  genvar i;
  logic a;

  for (i=1; i<0; i=i+1) begin: a
    ...                // error -- "a" conflicts with name of variable "a"
  end
endmodule

module mod_c;
  genvar i;

  for (i=1; i<5; i=i+1) begin: a
    ...
  end

  for (i=10; i<15; i=i+1) begin: a
    ...                // error -- "a" conflicts with name of previous
  
```

```

...           // loop even though indices are unique
end
endmodule

```

Example 2—A parameterized gray-code-to-binary-code converter module using a loop to generate continuous assignments

```

module gray2bin1 (bin, gray);
parameter SIZE = 8;           // this module is parameterizable
output [SIZE-1:0] bin;
input  [SIZE-1:0] gray;

genvar i;
generate
  for (i=0; i<SIZE; i=i+1) begin:bitnum
    assign bin[i] = ^gray[SIZE-1:i];
    // i refers to the implicitly defined localparam whose
    // value in each instance of the generate block is
    // the value of the genvar when it was elaborated.
  end
endgenerate
endmodule

```

The models in Example 3 and Example 4 are parameterized modules of ripple adders using a loop to generate SystemVerilog gate primitives. Example 3 uses a two-dimensional net declaration outside the generate loop to make the connections between the gate primitives while Example 4 makes the net declaration inside the generate loop to generate the wires needed to connect the gate primitives for each iteration of the loop.

Example 3—Generated ripple adder with two-dimensional net declaration outside the generate loop

```

module addergen1 (co, sum, a, b, ci);
parameter SIZE = 4;
output [SIZE-1:0] sum;
output          co;
input  [SIZE-1:0] a, b;
input          ci;
wire   [SIZE :0] c;
wire   [SIZE-1:0] t [1:3];
genvar          i;

assign c[0] = ci;

// Hierarchical gate instance names are:
// xor gates: bitnum[0].g1 bitnum[1].g1 bitnum[2].g1 bitnum[3].g1
//             bitnum[0].g2 bitnum[1].g2 bitnum[2].g2 bitnum[3].g2
// and gates: bitnum[0].g3 bitnum[1].g3 bitnum[2].g3 bitnum[3].g3
//             bitnum[0].g4 bitnum[1].g4 bitnum[2].g4 bitnum[3].g4
// or  gates: bitnum[0].g5 bitnum[1].g5 bitnum[2].g5 bitnum[3].g5
// Generated instances are connected with
// multidimensional nets t[1][3:0] t[2][3:0] t[3][3:0]
// (12 nets total)

for(i=0; i<SIZE; i=i+1) begin:bitnum
  xor g1 ( t[1][i],  a[i],  b[i]);
  xor g2 (  sum[i], t[1][i],  c[i]);
  and g3 ( t[2][i],  a[i],  b[i]);
  and g4 ( t[3][i], t[1][i],  c[i]);
end

```

```

        or g5 ( c[i+1], t[2][i], t[3][i]);
    end

    assign co = c[SIZE];
endmodule

```

Example 4—Generated ripple adder with net declaration inside the generate loop

```

module addergen1 (co, sum, a, b, ci);
    parameter SIZE = 4;
    output [SIZE-1:0] sum;
    output      co;
    input  [SIZE-1:0] a, b;
    input      ci;
    wire  [SIZE :0] c;

    genvar      i;

    assign c[0] = ci;

    // Hierarchical gate instance names are:
    // xor gates: bitnum[0].g1 bitnum[1].g1 bitnum[2].g1 bitnum[3].g1
    //             bitnum[0].g2 bitnum[1].g2 bitnum[2].g2 bitnum[3].g2
    // and gates: bitnum[0].g3 bitnum[1].g3 bitnum[2].g3 bitnum[3].g3
    //             bitnum[0].g4 bitnum[1].g4 bitnum[2].g4 bitnum[3].g4
    // or  gates: bitnum[0].g5 bitnum[1].g5 bitnum[2].g5 bitnum[3].g5
    // Gate instances are connected with nets named:
    //             bitnum[0].t1 bitnum[1].t1 bitnum[2].t1 bitnum[3].t1
    //             bitnum[0].t2 bitnum[1].t2 bitnum[2].t2 bitnum[3].t2
    //             bitnum[0].t3 bitnum[1].t3 bitnum[2].t3 bitnum[3].t3

    for(i=0; i<SIZE; i=i+1) begin:bitnum
        wire t1, t2, t3;

        xor g1 ( t1, a[i], b[i]);
        xor g2 ( sum[i], t1, c[i]);
        and g3 ( t2, a[i], b[i]);
        and g4 ( t3, t1, c[i]);
        or  g5 ( c[i+1], t2, t3);
    end

    assign co = c[SIZE];
endmodule

```

The hierarchical generate block instance names in a multilevel generate loop are shown in Example 5. For each block instance created by the generate loop, the generate block identifier for the loop is indexed by adding the “[genvar value]” to the end of the generate block identifier. These names can be used in hierarchical path names (see [23.6](#)).

Example 5—A multilevel generate loop

```

parameter SIZE = 2;
genvar i, j, k, m;
generate
    for (i=0; i<SIZE; i=i+1) begin:B1 // scope B1[i]
        M1 N1(); // instantiates B1[i].N1
        for (j=0; j<SIZE; j=j+1) begin:B2 // scope B1[i].B2[j]
            M2 N2(); // instantiates B1[i].B2[j].N2
        end
    end
endgenerate

```

```

    for (k=0; k<SIZE; k=k+1) begin:B3 // scope B1[i].B2[j].B3[k]
        M3 N3 (); // instantiates
    end // B1[i].B2[j].B3[k].N3
end
if (i>0) begin:B4 // scope B1[i].B4
    for (m=0; m<SIZE; m=m+1) begin:B5 // scope B1[i].B4.B5[m]
        M4 N4 (); // instantiates
    end // B1[i].B4.B5[m].N4
end
end
endgenerate

// Some examples of hierarchical names for the module instances:
// B1[0].N1 B1[1].N1
// B1[0].B2[0].N2 B1[0].B2[1].N2
// B1[0].B2[0].B3[0].N3 B1[0].B2[0].B3[1].N3
// B1[0].B2[1].B3[0].N3
// B1[1].B4.B5[0].N4 B1[1].B4.B5[1].N4

```

27.5 Conditional generate constructs

The conditional generate constructs, if-generate and case-generate, select at most one generate block from a set of alternative generate blocks based on constant expressions evaluated during elaboration. The selected generate block, if any, is instantiated into the model.

Generate blocks in conditional generate constructs can be named or unnamed, and they may consist of only one item, which need not be surrounded by **begin-end** keywords. Even if the **begin-end** keywords are absent, it is still a generate block, which, like all generate blocks, comprises a separate scope and a new level of hierarchy when it is instantiated.

Because at most one of the alternative generate blocks is instantiated, it is permissible for there to be more than one block with the same name within a single conditional generate construct. It is not permissible for any of the named generate blocks to have the same name as generate blocks in any other conditional or loop generate construct in the same scope, even if the blocks with the same name are not selected for instantiation. It is not permissible for any of the named generate blocks to have the same name as any other declaration in the same scope, even if that block is not selected for instantiation.

If the generate block selected for instantiation is named, then this name declares a generate block instance and is the name for the scope it creates. Normal rules for hierarchical naming apply. If the generate block selected for instantiation is not named, it still creates a scope; but the declarations within it cannot be referenced using hierarchical names other than from within the hierarchy instantiated by the generate block itself.

If a generate block in a conditional generate construct consists of only one item that is itself a conditional generate construct and if that item is not surrounded by **begin-end** keywords, then this generate block is not treated as a separate scope. The generate construct within this block is said to be directly nested. The generate blocks of the directly nested construct are treated as if they belong to the outer construct. Therefore, they can have the same name as the generate blocks of the outer construct, and they cannot have the same name as any declaration in the scope enclosing the outer construct (including other generate blocks in other generate constructs in that scope). This allows complex conditional generate schemes to be expressed without creating unnecessary levels of generate block hierarchy.

The most common use of this would be to create an **if-else-if** generate scheme with any number of **else-if** clauses, all of which can have generate blocks with the same name because only one will be selected for instantiation. It is permissible to combine if-generate and case-generate constructs in the same

complex generate scheme. Direct nesting applies only to conditional generate constructs nested in conditional generate constructs. It does not apply in any way to loop generate constructs.

Example 1

```

module test;
  parameter p = 0, q = 0;
  wire a, b, c;

  //-----
  // Code to either generate a u1.g1 instance or no instance.
  // The u1.g1 instance of one of the following gates:
  // (and, or, xor, xnor) is generated if
  // {p,q} == {1,0}, {1,2}, {2,0}, {2,1}, {2,2}, {2, default}
  //-----

  if (p == 1)
    if (q == 0)
      begin : u1          // If p==1 and q==0, then instantiate
        and g1(a, b, c); // AND with hierarchical name test.u1.g1
      end
    else if (q == 2)
      begin : u1          // If p==1 and q==2, then instantiate
        or g1(a, b, c); // OR with hierarchical name test.u1.g1
      end
      // "else" added to end "if (q == 2)" statement
    else ;              // If p==1 and q!=0 or 2, then no instantiation
  else if (p == 2)
    case (q)
      0, 1, 2:
        begin : u1          // If p==2 and q==0,1, or 2, then instantiate
          xor g1(a, b, c); // XOR with hierarchical name test.u1.g1
        end
      default:
        begin : u1          // If p==2 and q!=0,1, or 2, then instantiate
          xnor g1(a, b, c); // XNOR with hierarchical name test.u1.g1
        end
    endcase
  endmodule

```

This generate construct will select at most one of the generate blocks named u1. The hierarchical name of the gate instantiation in that block would be test.u1.g1. When nesting if-generate constructs, the **else** always belongs to the nearest **if** construct.

NOTE—As in the example above, an **else** with a null generate block can be inserted to make a subsequent **else** belong to an outer **if** construct. **begin-end** keywords can also be used to disambiguate. However, this would violate the criteria for direct nesting, and an extra level of generate block hierarchy would be created.

Conditional generate constructs make it possible for a module to contain an instantiation of itself. The same can be said of loop generate constructs, but it is more easily done with conditional generates. With proper use of parameters, the resulting recursion can be made to terminate, resulting in a legitimate model hierarchy. Because of the rules for determining top-level modules, a module containing an instantiation of itself will not be a top-level module.

Example 2—An implementation of a parameterized multiplier module

```

module multiplier(a,b,product);
  parameter a_width = 8, b_width = 8;

```

```

localparam product_width = a_width+b_width;
    // cannot be modified directly with the defparam
    // statement or the module instance statement #
input [a_width-1:0] a;
input [b_width-1:0] b;
output [product_width-1:0] product;

generate
    if((a_width < 8) || (b_width < 8)) begin: mult
        CLA_multiplier #(a_width,b_width) u1(a, b, product);
        // instantiate a CLA multiplier
    end
    else begin: mult
        WALLACE_multiplier #(a_width,b_width) u1(a, b, product);
        // instantiate a Wallace-tree multiplier
    end
endgenerate
    // The hierarchical instance name is mult.u1
endmodule

```

Example 3—Generate with a case to handle widths less than 3

```

generate
    case (WIDTH)
        1: begin: adder // 1-bit adder implementation
            adder_1bit x1(co, sum, a, b, ci);
        end
        2: begin: adder // 2-bit adder implementation
            adder_2bit x1(co, sum, a, b, ci);
        end
        default:
            begin: adder // others - carry look-ahead adder
                adder_cla #(WIDTH) x1(co, sum, a, b, ci);
            end
    endcase
    // The hierarchical instance name is adder.x1
endgenerate

```

Example 4—A module of memory dimm

```

module dimm(addr, ba, rasx, casx, csx, wex, cke, clk, dqm, data, dev_id);

    parameter [31:0] MEM_WIDTH = 16, MEM_SIZE = 8; // in mbytes

    input [10:0] addr;
    input ba, rasx, casx, csx, wex, cke, clk;
    input [ 7:0] dqm;
    inout [63:0] data;
    input [ 4:0] dev_id;

    genvar i;

    case ({MEM_SIZE, MEM_WIDTH})
        {32'd8, 32'd16}: // 8Meg x 16 bits wide
            begin: memory
                for (i=0; i<4; i=i+1) begin:word16
                    sms_08b216t0 p(.clk(clk), .csb(csx), .cke(cke),.ba(ba),
                        .addr(addr), .rasb(rasx), .casb(casx),

```



```

        .web(wex), .udqm(dqm[2*i+1]), .ldqm(dqm[2*i]),
        .dqi(data[15+16*i:16*i]), .dev_id(dev_id));
// The hierarchical instance names are:
// memory.word16[3].p, memory.word16[2].p,
// memory.word16[1].p, memory.word16[0].p,
// and the task memory.read_mem
end
task read_mem;
    input [31:0] address;
    output [63:0] data;
    begin // call read_mem in sms module
        word[3].p.read_mem(address, data[63:48]);
        word[2].p.read_mem(address, data[47:32]);
        word[1].p.read_mem(address, data[31:16]);
        word[0].p.read_mem(address, data[15: 0]);
    end
endtask
end
{32'd16, 32'd8}: // 16Meg x 8 bits wide
begin: memory
    for (i=0; i<8; i=i+1) begin:word8
        sms_16b208t0 p(.clk(clk), .csb(csx), .cke(cke), .ba(ba),
            .addr(addr), .rasb(rasx), .casb(casx),
            .web(wex), .dqm(dqm[i]),
            .dqi(data[7+8*i:8*i]), .dev_id(dev_id));
// The hierarchical instance names are
// memory.word8[7].p, memory.word8[6].p,
// ...
// memory.word8[1].p, memory.word8[0].p,
// and the task memory.read_mem
    end
    task read_mem;
        input [31:0] address;
        output [63:0] data;
        begin // call read_mem in sms module
            byte[7].p.read_mem(address, data[63:56]);
            byte[6].p.read_mem(address, data[55:48]);
            byte[5].p.read_mem(address, data[47:40]);
            byte[4].p.read_mem(address, data[39:32]);
            byte[3].p.read_mem(address, data[31:24]);
            byte[2].p.read_mem(address, data[23:16]);
            byte[1].p.read_mem(address, data[15: 8]);
            byte[0].p.read_mem(address, data[ 7: 0]);
        end
    endtask
end
// Other memory cases ...
endcase
endmodule

```

27.6 External names for unnamed generate blocks

Although an unnamed generate block has no name that can be used in a hierarchical name, it needs to have a name by which external interfaces can refer to it. A name will be assigned for this purpose to each unnamed generate block as described in the next paragraph.

Each generate construct in a given scope is assigned a number. The number will be 1 for the construct that appears textually first in that scope and will increase by 1 for each subsequent generate construct in that scope. All unnamed generate blocks will be given the name “genblk<n>” where <n> is the number assigned to its enclosing generate construct. If such a name would conflict with an explicitly declared name, then leading zeros are added in front of the number until the name does not conflict.

NOTE—Each generate construct is assigned its number as described in the previous paragraph even if it does not contain any unnamed generate blocks.

For example:

```

module top;

  parameter genblk2 = 0;
  genvar i;

  // The following generate block is implicitly named genblk1

  if (genblk2) logic a; // top.genblk1.a
  else         logic b; // top.genblk1.b

  // The following generate block is implicitly named genblk02
  // as genblk2 is already a declared identifier

  if (genblk2) logic a; // top.genblk02.a
  else         logic b; // top.genblk02.b

  // The following generate block would have been named genblk3
  // but is explicitly named g1

  for (i = 0; i < 1; i = i + 1) begin : g1 // block name
    // The following generate block is implicitly named genblk1
    // as the first nested scope inside g1
    if (1) logic a; // top.g1[0].genblk1.a
  end

  // The following generate block is implicitly named genblk4 since
  // it belongs to the fourth generate construct in scope "top".
  // The previous generate block would have been
  // named genblk3 if it had not been explicitly named g1

  for (i = 0; i < 1; i = i + 1)
    // The following generate block is implicitly named genblk1
    // as the first nested generate block in genblk4
    if (1) logic a; // top.genblk4[0].genblk1.a

  // The following generate block is implicitly named genblk5
  if (1) logic a; // top.genblk5.a

endmodule

```

28. Gate-level and switch-level modeling

28.1 General

This clause describes the following:

- Gate and switch primitives
- Logic strength modeling
- Gate and net delays

28.2 Overview

This clause describes the syntax and semantics of the built-in primitives of gate- and switch-level modeling and how a hardware design can be described using these primitives.

There are 14 logic gates and 12 switches predefined in the SystemVerilog to provide the *gate*- and *switch*-level modeling facility. Modeling with logic gates and switches has the following advantages:

- Gates provide a much closer one-to-one mapping between the actual circuit and the model.
- There is no continuous assignment equivalent to the bidirectional transfer gate.

28.3 Gate and switch declaration syntax

[Syntax 28-1](#) shows the gate and switch declaration syntax.

A gate or a switch instance declaration shall have the following specifications:

- The keyword that names the type of gate or switch primitive
- An optional *drive strength*
- An optional *propagation delay*
- An optional identifier that names each gate or switch instance
- An optional range for *array of instances*
- The terminal connection list

Multiple instances of the one type of gate or switch primitive can be declared as a comma-separated list. All such instances shall have the same drive strength and delay specification.

```
gate_instantiation ::= //from A.3.1
    cmos_switchtype [delay3] cmos_switch_instance { , cmos_switch_instance } ;
    | enable_gatetype [drive_strength] [delay3] enable_gate_instance { , enable_gate_instance } ;
    | mos_switchtype [delay3] mos_switch_instance { , mos_switch_instance } ;
    | n_input_gatetype [drive_strength] [delay2] n_input_gate_instance { , n_input_gate_instance } ;
    | n_output_gatetype [drive_strength] [delay2] n_output_gate_instance
      { , n_output_gate_instance } ;
    | pass_en_switchtype [delay2] pass_enable_switch_instance { , pass_enable_switch_instance } ;
    | pass_switchtype pass_switch_instance { , pass_switch_instance } ;
    | pulldown [pulldown_strength] pull_gate_instance { , pull_gate_instance } ;
    | pullup [pullup_strength] pull_gate_instance { , pull_gate_instance } ;
cmos_switch_instance ::= [ name_of_instance ] ( output_terminal , input_terminal ,
    ncontrol_terminal , pcontrol_terminal )
enable_gate_instance ::= [ name_of_instance ] ( output_terminal , input_terminal , enable_terminal )
```

```

mos_switch_instance ::= [ name_of_instance ] ( output_terminal , input_terminal , enable_terminal )
n_input_gate_instance ::= [ name_of_instance ] ( output_terminal , input_terminal { , input_terminal } )
n_output_gate_instance ::= [ name_of_instance ] ( output_terminal { , output_terminal } ,
input_terminal )
pass_switch_instance ::= [ name_of_instance ] ( inout_terminal , inout_terminal )
pass_enable_switch_instance ::= [ name_of_instance ] ( inout_terminal , inout_terminal ,
enable_terminal )
pull_gate_instance ::= [ name_of_instance ] ( output_terminal )
pulldown_strength ::= //from A.3.2
    ( strength0 , strength1 )
  | ( strength1 , strength0 )
  | ( strength0 )
pullup_strength ::=
    ( strength0 , strength1 )
  | ( strength1 , strength0 )
  | ( strength1 )
enable_terminal ::= expression //from A.3.3
inout_terminal ::= net_lvalue
input_terminal ::= expression
ncontrol_terminal ::= expression
output_terminal ::= net_lvalue
pcontrol_terminal ::= expression
cmos_switchtype ::= cmos | rcmos //from A.3.4
enable_gatetype ::= bufif0 | bufif1 | notif0 | notif1
mos_switchtype ::= nmos | pmos | rnmos | rpmos
n_input_gatetype ::= and | nand | or | nor | xor | xnor
n_output_gatetype ::= buf | not
pass_en_switchtype ::= tranif0 | tranif1 | rtranif1 | rtranif0
pass_switchtype ::= tran | rtran
name_of_instance ::= instance_identifier { unpacked_dimension } //from A.4.1.1

```

Syntax 28-1—Syntax for gate instantiation (excerpt from [Annex A](#))

28.3.1 The gate type specification

A gate or switch instance declaration shall begin with the keyword that specifies the gate or switch primitive being used by the instances that follow in the declaration. [Table 28-1](#) lists the keywords that shall begin a gate or a switch instance declaration.

Table 28-1—Built-in gates and switches

n_input gates	n_output gates	Three-state gates	Pull gates	MOS switches	Bidirectional switches
and	buf	bufif0	pulldown	cmos	rtran
nand	not	bufif1	pullup	nmos	rtranif0
nor		notif0		pmos	rtranif1

Table 28-1—Built-in gates and switches (continued)

n_input gates	n_output gates	Three-state gates	Pull gates	MOS switches	Bidirectional switches
or		notif1		rcmos	tran
xnor				rnmos	tranif0
xor				rpmos	tranif1

Explanations of the built-in gates and switches shown in [Table 28-1](#) begin in [28.4](#).

28.3.2 The drive strength specification

An optional drive strength specification shall specify the *strength* of the logic values on the output terminals of the gate instance. Only the instances of the gate primitives shown in [Table 28-2](#) can have the drive strength specification.

Table 28-2—Valid gate types for strength specifications

and	nand	buf	not	pulldown
or	nor	bufif0	notif0	pullup
xor	xnor	bufif1	notif1	—

The drive strength specification for a gate instance, with the exception of **pullup** and **pulldown**, shall have a *strength1* specification and a *strength0* specification. The *strength1* specification shall specify the strength of signals with a logic value 1, and the *strength0* specification shall specify the strength of signals with a logic value 0. The strength specification shall follow the gate type keyword and precede any delay specification. The *strength0* specification can precede or follow the *strength1* specification. The *strength1* and *strength0* specifications shall be separated by a comma and enclosed within a pair of parentheses.

The **pullup** gate shall have one of the following: no strength specification, only a *strength1* specification, or both *strength1* and *strength0* specifications. The **pulldown** gate shall have one of the following: no strength specification, only a *strength0* specification, or both *strength1* and *strength0* specifications. See [28.10](#) for more details.

The *strength1* specification shall be one of the following keywords:

supply1 strong1 pull1 weak1

The *strength0* specification shall be one of the following keywords:

supply0 strong0 pull0 weak0

Specifying **highz1** as *strength1* shall cause the gate or switch to output a logic value *z* in place of a 1. Specifying **highz0** shall cause the gate to output a logic value *z* in place of a 0. The strength specifications (**highz0**, **highz1**) and (**highz1**, **highz0**) shall be considered invalid.

In the absence of a strength specification, the instances shall have the default strengths **strong1** and **strong0**.

The following example shows a drive strength specification in a declaration of an open collector **nor** gate:

```
nor (highz1,strong0) n1(out1,in1,in2);
```

In this example, the **nor** gate outputs a *z* in place of a 1.

Logic strength modeling is discussed in more detail in [28.11](#) through [28.15](#).

28.3.3 The delay specification

An optional delay specification shall specify the propagation delay through the gates and switches in a declaration. Gates and switches in declarations with no delay specification shall have no propagation delay. A delay specification can contain up to three delay values, depending on the gate type. The **pullup** and **pulldown** instance declarations shall not include delay specifications. Delays are discussed in more detail in [28.16](#).

28.3.4 The primitive instance identifier

An optional name can be given to a gate or switch instance. If multiple instances are declared as an array of instances, an identifier shall be used to name the instances.

28.3.5 The range specification

There are many situations when repetitive instances are required. These instances shall differ from each other only by the index of the vector to which they are connected.

In order to specify an array of instances, the instance name shall be followed by the range specification. The range shall be specified by two constant expressions, left-hand index (*lhi*) and right-hand index (*rhi*), separated by a colon and enclosed within a pair of square brackets. A [*lhi*:*rhi*] range specification shall represent an array of $\text{abs}(lhi-rhi)+1$ instances. Neither of the two constant expressions are required to be zero, and *lhi* is not required to be larger than *rhi*. If both constant expressions are equal, only one instance shall be generated.

An array of instances shall have a continuous range. One instance identifier shall be associated with only one range to declare an array of instances.

The range specification shall be optional. If no range specification is given, a single instance shall be created.

For example:

The following declaration is illegal:

```
nand #2 t_nand[0:3] ( ... ), t_nand[4:7] ( ... );
```

It could be declared correctly as one array of eight instances or as two arrays with unique names of four elements each, as follows:

```
nand #2 t_nand[0:7] ( ... );  
nand #2 x_nand[0:3] ( ... ), y_nand[4:7] ( ... );
```

28.3.6 Primitive instance connection list

The terminal list describes how the gate or switch connects to the rest of the model. The gate or switch type can limit these expressions. The connection list shall be enclosed in a pair of parentheses, and the terminals

shall be separated by commas. The output or bidirectional terminals shall always come first in the terminal list, followed by the input terminals.

The terminal connections for an array of instances shall follow these rules:

- The bit length of each port expression in the declared instance-array shall be compared with the bit length of each single-instance port or terminal in the instantiated module or primitive.
- For each port or terminal where the bit length of the instance-array port expression is the same as the bit length of the single-instance port, the instance-array port expression shall be connected to each single-instance port.
- If bit lengths are different, each instance shall get a part-select of the port expression as specified in the range, starting with the right-hand index.
- If bit lengths are different, each instance shall get a part-select of the port expression, of a bit length equal to the instance port bit length. The least significant bit of the port expression shall be connected to the instance corresponding to the right-hand index of the array range.
- Too many or too few bits to connect to all the instances shall be considered an error.

An individual instance from an array of instances shall be referenced in the same manner as referencing an element of an array of **logic** types.

For example:

Example 1—The following declaration of `nand_array` declares four instances that can be referenced by `nand_array[1]`, `nand_array[2]`, `nand_array[3]`, and `nand_array[4]`, respectively.

```
nand #2 nand_array[1:4] ( ... ) ;
```

Example 2—The two module descriptions that follow are equivalent except for indexed instance names, and they demonstrate the range specification and connection rules for declaring an array of instances:

```
module driver (in, out, en);
  input  [3:0] in;
  output [3:0] out;
  input          en;

  bufif0 ar[3:0] (out, in, en); // array of three-state buffers
endmodule

module driver_equiv (in, out, en);
  input  [3:0] in;
  output [3:0] out;
  input          en;

  bufif0 ar3 (out[3], in[3], en); // each buffer declared separately
  bufif0 ar2 (out[2], in[2], en);
  bufif0 ar1 (out[1], in[1], en);
  bufif0 ar0 (out[0], in[0], en);
endmodule
```

Example 3—The two module descriptions that follow are equivalent except for indexed instance names, and they demonstrate how different instances within an array of instances are connected when the port sizes do not match:

```

module busdriver (busin, bushigh, buslow, enh, enl);
  input  [15:0] busin;
  output [ 7:0] bushigh, buslow;
  input      enh, enl;

  driver busar3 (busin[15:12], bushigh[7:4], enh);
  driver busar2 (busin[11:8], bushigh[3:0], enh);
  driver busar1 (busin[7:4], buslow[7:4], enl);
  driver busar0 (busin[3:0], buslow[3:0], enl);

endmodule

module busdriver_equiv (busin, bushigh, buslow, enh, enl);
  input  [15:0] busin;
  output [ 7:0] bushigh, buslow;
  input      enh, enl;

  driver busar[3:0] (.out({bushigh, buslow}), .in(busin),
                    .en({enh, enh, enl, enl}));

endmodule

```

Example 4—This example demonstrates how a series of modules can be chained together. [Figure 28-1](#) shows an equivalent schematic interconnection of DFF instances.

```

module dffn (q, d, clk);
  parameter bits = 1;
  input  [bits-1:0] d;
  output [bits-1:0] q;
  input      clk ;

  DFF dff[bits-1:0] (q, d, clk); // create a row of D flip-flops

endmodule

module MxN_pipeline (in, out, clk);
  parameter M = 3, N = 4; // M=width,N=depth
  input  [M-1:0] in;
  output [M-1:0] out;
  input      clk;
  wire [M*(N-1):1] t;

  // #(M) redefines the bits parameter for dffn
  // create p[1:N] columns of dffn rows (pipeline)

  dffn #(M) p[1:N] ({out, t}, {t, in}, clk);

endmodule

```

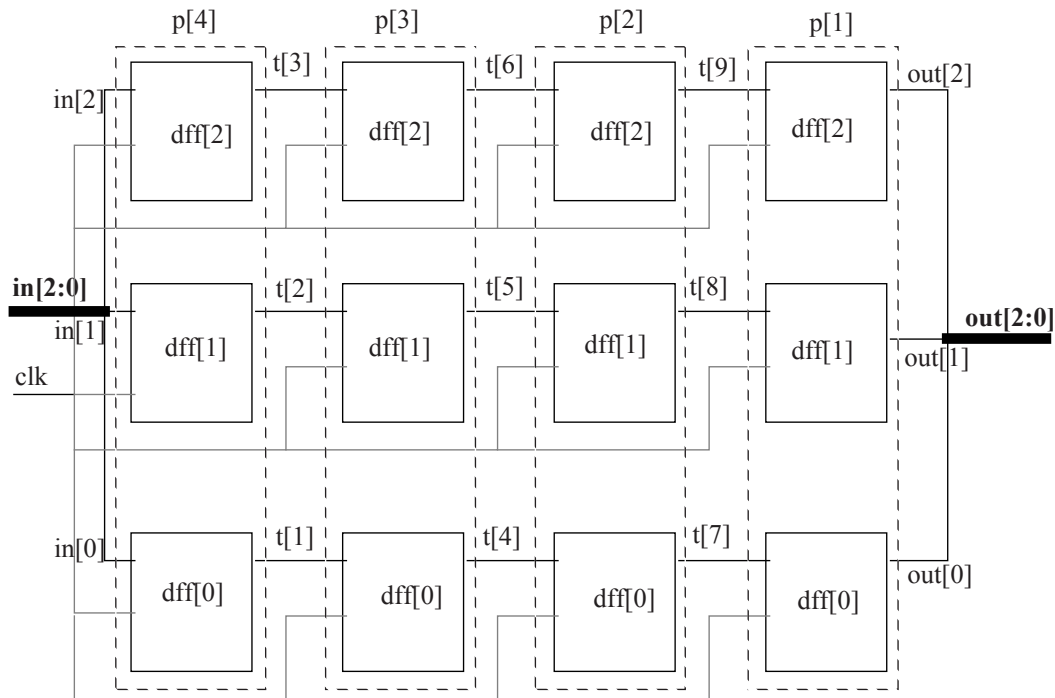

Figure 28-1—Schematic diagram of interconnections in array of instances

28.4 and, nand, nor, or, xor, and xnor gates

The instance declaration of a multiple input logic gate shall begin with one of the following keywords:

and nand nor or xor xnor

The delay specification shall be zero, one, or two delays. If the specification contains two delays, the first delay shall determine the output rise delay, the second delay shall determine the output fall delay, and the smaller of the two delays shall apply to output transitions to \times . If only one delay is specified, it shall specify both the rise delay and the fall delay. If there is no delay specification, there shall be no propagation delay through the gate.

These six logic gates shall have one output and one or more inputs. The first terminal in the terminal list shall connect to the output of the gate and all other terminals connect to its inputs.

The truth tables for these gates, showing the result of two input values, appear in [Table 28-3](#).

Table 28-3—Truth tables for multiple input logic gates

and	0	1	x	z
0	0	0	0	0
1	0	1	x	x
x	0	x	x	x
z	0	x	x	x

or	0	1	x	z
0	0	1	x	x
1	1	1	1	1
x	x	1	x	x
z	x	1	x	x

xor	0	1	x	z
0	0	1	x	x
1	1	0	x	x
x	x	x	x	x
z	x	x	x	x

nand	0	1	x	z
0	1	1	1	1
1	1	0	x	x
x	1	x	x	x
z	1	x	x	x

nor	0	1	x	z
0	1	0	x	x
1	0	0	0	0
x	x	0	x	x
z	x	0	x	x

xnor	0	1	x	z
0	1	0	x	x
1	0	1	x	x
x	x	x	x	x
z	x	x	x	x

Versions of these six logic gates having more than two inputs shall have a natural extension, but the number of inputs shall not alter propagation delays.

For example:

The following example declares a two-input **and** gate:

```
and a1 (out, in1, in2);
```

The inputs are *in1* and *in2*. The output is *out*. The instance name is *a1*.

28.5 buf and not gates

The instance declaration of a multiple output logic gate shall begin with one of the following keywords:

buf **not**

The delay specification shall be zero, one, or two delays. If the specification contains two delays, the first delay shall determine the output rise delay, the second delay shall determine the output fall delay, and the smaller of the two delays shall apply to output transitions to *x*. If only one delay is specified, it shall specify both the rise delay and the fall delay. If there is no delay specification, there shall be no propagation delay through the gate.

These two logic gates shall have one input and one or more outputs. The last terminal in the terminal list shall connect to the input of the logic gate, and the other terminals shall connect to the outputs of the logic gate.

Truth tables for these logic gates with one input and one output are shown in [Table 28-4](#).

Table 28-4—Truth tables for multiple output logic gates

buf		not	
input	output	input	output
0	0	0	1
1	1	1	0
x	x	x	x
z	x	z	x

The following example declares a two-output **buf**:

```
buf b1 (out1, out2, in);
```

The input is `in`. The outputs are `out1` and `out2`. The instance name is `b1`.

28.6 bufif1, bufif0, notif1, and notif0 gates

The instance declaration of these three-state logic gates shall begin with one of the following keywords:

```
bufif0      bufif1      notif1      notif0
```

These four logic gates model three-state drivers. In addition to logic values 1 and 0, these gates can output `z`.

The delay specification shall be zero, one, two, or three delays. If the delay specification contains three delays, the first delay shall determine the rise delay, the second delay shall determine the fall delay, the third delay shall determine the delay of transitions to `z`, and the smallest of the three delays shall determine the delay of transitions to `x`. If the specification contains two delays, the first delay shall determine the output rise delay, the second delay shall determine the output fall delay, and the smaller of the two delays shall apply to output transitions to `x` and `z`. If only one delay is specified, it shall specify the delay for all output transitions. If there is no delay specification, there shall be no propagation delay through the gate.

Some combinations of data input values and control input values can cause these gates to output either of two values, without a preference for either value (see 28.12.2). The logic tables for these gates include two symbols representing such unknown results. The symbol `L` shall represent a result that has a value 0 or `z`. The symbol `H` shall represent a result that has a value 1 or `z`. Delays on transitions to `H` or `L` shall be treated the same as delays on transitions to `x`.

These four logic gates shall have one output, one data input, and one control input. The first terminal in the terminal list shall connect to the output, the second terminal shall connect to the data input, and the third terminal shall connect to the control input.

[Table 28-5](#) presents the logic tables for these gates.

Table 28-5—Truth tables for three-state logic gates

bufif0	CONTROL				
		0	1	x	z
D	0	0	z	L	L
A	1	1	z	H	H
T	x	x	z	x	x
A	z	x	z	x	x

bufif1	CONTROL				
		0	1	x	z
D	0	z	0	L	L
A	1	z	1	H	H
T	x	z	x	x	x
A	z	z	x	x	x

notif0	CONTROL				
		0	1	x	z
D	0	1	z	H	H
A	1	0	z	L	L
T	x	x	z	x	x
A	z	x	z	x	x

notif1	CONTROL				
		0	1	x	z
D	0	z	1	H	H
A	1	z	0	L	L
T	x	z	x	x	x
A	z	z	x	x	x

The following example declares an instance of **bufif1**:

```
bufif1 bf1 (outw, inw, controlw);
```

The output is **outw**, the input is **inw**, and the control is **controlw**. The instance name is **bf1**.

28.7 MOS switches

The instance declaration of a MOS switch shall begin with one of the following keywords:

cmos **nmos** **pmos** **rcmos** **rnmos** **rpmos**

The **cmos** and **rcmos** switches are described in [28.9](#).

The **pmos** keyword stands for the P-type metal-oxide semiconductor (PMOS) transistor and the **nmos** keyword stands for the N-type metal-oxide semiconductor (NMOS) transistor. PMOS and NMOS transistors have relatively low impedance between their sources and drains when they conduct. The **rpmos** keyword stands for resistive PMOS transistor and the **rnmos** keyword stands for resistive NMOS transistor. Resistive PMOS and resistive NMOS transistors have significantly higher impedance between their sources and drains when they conduct than PMOS and NMOS transistors have. The load devices in static MOS networks are examples of **rpmos** and **rnmos** transistors. These four switches are *unidirectional channels* for data similar to the **bufif** gates.

The delay specification shall be zero, one, two, or three delays. If the delay specification contains three delays, the first delay shall determine the rise delay, the second delay shall determine the fall delay, the third delay shall determine the delay of transitions to z, and the smallest of the three delays shall determine the delay of transitions to x. If the specification contains two delays, the first delay shall determine the output

rise delay, the second delay shall determine the output fall delay, and the smaller of the two delays shall apply to output transitions to *x* and *z*. If only one delay is specified, it shall specify the delay for all output transitions. If there is no delay specification, there shall be no propagation delay through the switch.

Some combinations of data input values and control input values can cause these switches to output either of two values, without a preference for either value. The logic tables for these switches include two symbols representing such unknown results. The symbol *L* represents a result that has a value 0 or *z*. The symbol *H* represents a result that has a value 1 or *z*. Delays on transitions to *H* and *L* shall be the same as delays on transitions to *x*.

These four switches shall have one output, one data input, and one control input. The first terminal in the terminal list shall connect to the output, the second terminal shall connect to the data input, and the third terminal shall connect to the control input.

The **nmos** and **pmos** switches shall pass signals from their inputs and through their outputs with a change in the strength of the signal in only one case, as discussed in 28.13. The **rnmos** and **rpmos** switches shall reduce the strength of signals that propagate through them, as discussed in 28.14.

Table 28-6 presents the logic tables for these switches.

Table 28-6—Truth tables for MOS switches

	CONTROL				
	0	1	x	z	
D	0	0	z	L	L
A	1	1	z	H	H
T	x	x	z	x	x
A	z	z	z	z	z

	CONTROL				
	0	1	x	z	
D	0	z	0	L	L
A	1	z	1	H	H
T	x	z	x	x	x
A	z	z	z	z	z

The following example declares a **pmos** switch:

```
pmos p1 (out, data, control);
```

The output is *out*, the data input is *data*, and the control input is *control*. The instance name is *p1*.

28.8 Bidirectional pass switches

The instance declaration of a bidirectional pass switch shall begin with one of the following keywords:

```
tran          tranif1      tranif0
rtran         rtranif1     rtranif0
```

The bidirectional pass switches shall not delay signals propagating through them. When **tranif0**, **tranif1**, **rtranif0**, or **rtranif1** devices are turned off, they shall block signals; and when they are turned on, they shall pass signals. The **tran** and **rtran** devices cannot be turned off; they shall always pass signals.

The delay specifications for **tranif1**, **tranif0**, **rtranif1**, and **rtranif0** devices shall be zero, one, or two delays. If the specification contains two delays, the first delay shall determine the *turn-on delay*, the second delay shall determine the *turn-off delay*, and the smaller of the two delays shall apply to output transitions to *x* and *z*. If only one delay is specified, it shall specify both the turn-on and the turn-off delays. If there is no delay specification, there shall be no turn-on or turn-off delay for the bidirectional pass switch.

The bidirectional pass switches **tran** and **rtran** shall not accept delay specification.

The **tranif1**, **tranif0**, **rtranif1**, and **rtranif0** devices shall have three items in their terminal lists. The first two shall be bidirectional terminals that conduct signals to and from the devices, and the third terminal shall connect to a control input. The **tran** and **rtran** devices shall have terminal lists containing two bidirectional terminals. Both bidirectional terminals shall unconditionally conduct signals to and from the devices, allowing signals to pass in either direction through the devices. The bidirectional terminals of all six devices shall be connected only to scalar nets or bit-selects of vector nets.

The **tran**, **tranif0**, and **tranif1** devices shall pass signals with an alteration in their strength in only one case, as discussed in [28.13](#). The **rtran**, **rtranif0**, and **rtranif1** devices shall reduce the strength of the signals passing through them according to rules discussed in [28.14](#).

The following example declares an instance of **tranif1**:

```
tranif1 t1 (inout1,inout2,control);
```

The bidirectional terminals are *inout1* and *inout2*. The control input is *control*. The instance name is *t1*.

28.9 CMOS switches

The instance declaration of a CMOS switch shall begin with one of the following keywords:

```
cmos                      rcmos
```

The delay specification shall be zero, one, two, or three delays. If the delay specification contains three delays, the first delay shall determine the rise delay, the second delay shall determine the fall delay, the third delay shall determine the delay of transitions to *z*, and the smallest of the three delays shall determine the delay of transitions to *x*. Delays in transitions to *H* or *L* are the same as delays in transitions to *x*. If the specification contains two delays, the first delay shall determine the output rise delay, the second delay shall determine the output fall delay, and the smaller of the two delays shall apply to output transitions to *x* and *z*. If only one delay is specified, it shall specify the delay for all output transitions. If there is no delay specification, there shall be no propagation delay through the switch.

The **cmos** and **rcmos** switches shall have a data input, a data output, and two control inputs. In the terminal list, the first terminal shall connect to the data output, the second terminal shall connect to the data input, the third terminal shall connect to the n-channel control input, and the last terminal shall connect to the p-channel control input.

The **cmos** gate shall pass signals with an alteration in their strength in only one case, as discussed in [28.13](#). The **rcmos** gate shall reduce the strength of signals passing through it according to rules described in [28.14](#).

The **cmos** switch shall be treated as the combination of a **pmos** switch and an **nmos** switch. The **rcmos** switch shall be treated as the combination of an **rpmos** switch and an **rnmos** switch. The combined switches in these configurations shall share data input and data output terminals, but they shall have separate control inputs.

The equivalence of the **cmos** gate to the pairing of an **nmos** gate and a **pmos** gate is shown in the following example:

```
cmos (w, datain, ncontrol, pcontrol);
```

is equivalent to:

```
nmos (w, datain, ncontrol);  
pmos (w, datain, pcontrol);
```

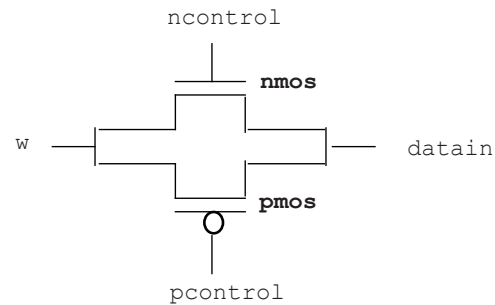

28.10 pullup and pulldown sources

The instance declaration of a pullup or a pulldown source shall begin with one of the following keywords:

pullup **pulldown**

A **pullup** source shall place a logic value 1 on the nets connected in its terminal list. A **pulldown** source shall place a logic value 0 on the nets connected in its terminal list.

The signals that these sources place on nets shall have **pull** strength in the absence of a strength specification. If there is a *strength1* specification on a **pullup** source or a *strength0* specification on a **pulldown** source, the signals shall have the strength specified. A *strength0* specification on a **pullup** source and a *strength1* specification on a **pulldown** source shall be ignored.

There shall be no delay specifications for these sources.

The following example declares two **pullup** instances:

```
pullup (strong1) p1 (neta), p2 (netb);
```

In this example, the p1 instance drives neta and the p2 instance drives netb with **strong** strength.

28.11 Logic strength modeling

The SystemVerilog provides for accurate modeling of signal contention, bidirectional pass gates, resistive MOS devices, dynamic MOS, charge sharing, and other technology-dependent network configurations by allowing scalar net signal values to have a full range of unknown values and different levels of strength or combinations of levels of strength. This multiple-level logic strength modeling resolves combinations of signals into known or unknown values to represent the behavior of hardware with improved accuracy.

A strength specification shall have the following two components:

- a) The strength of the 0 portion of the net value, called *strength0*, designated as one of the following:

supply0 **strong0** **pull10** **weak0** **highz0**

- b) The strength of the 1 portion of the net value, called *strength1*, designated as one of the following:

supply1 strong1 pull1 weak1 highz1

The combinations (**highz0**, **highz1**) and (**highz1**, **highz0**) shall be considered illegal.

Despite this division of the strength specification, it is helpful to consider strength as a property occupying regions of a continuum in order to predict the results of combinations of signals.

[Table 28-7](#) demonstrates the continuum of strengths. The left column lists the keywords used in specifying strengths. The right column gives correlated strength levels.

Table 28-7—Strength levels for scalar net signal values

Strength name	Strength level
supply0	7
strong0	6
pull0	5
large0	4
weak0	3
medium0	2
small0	1
highz0	0
highz1	0
small1	1
medium1	2
weak1	3
large1	4
pull1	5
strong1	6
supply1	7

In [Table 28-7](#), there are four *driving strengths*:

supply strong pull weak

Signals with driving strengths shall propagate from gate outputs and continuous assignment outputs.

In [Table 28-7](#), there are three *charge storage strengths*:

large medium small

Signals with the charge storage strengths shall originate in the **triereg** net type.

It is possible to think of the strengths of signals in [Table 28-7](#) as locations on the scale in [Figure 28-2](#).

strength0								strength1							
7	6	5	4	3	2	1	0	0	1	2	3	4	5	6	7
Su0	St0	Pu0	La0	We0	Me0	Sm0	HiZ0	HiZ1	Sm1	Me1	We1	La1	Pu1	St1	Su1

Figure 28-2—Scale of strengths

Discussions of signal combinations later in this clause employ graphics similar to those used in [Figure 28-2](#).

If the signal value of a net is known, all of its strength levels shall be in either the *strength0* part of the scale represented by [Figure 28-2](#), or all strength levels shall be in its *strength1* part. If the signal value of a net is unknown, it shall have strength levels in both the *strength0* and the *strength1* parts. A net with a signal value *z* shall have a strength level only in one of the 0 subdivisions of the parts of the scale.

28.12 Strengths and values of combined signals

In addition to a signal value, a net shall have either a single unambiguous strength level or an ambiguous strength consisting of more than one level. When signals combine, their strengths and values shall determine the strength and value of the resulting signal in accordance with the principles in [28.12.1](#) through [28.12.4](#).

28.12.1 Combined signals of unambiguous strength

This subclause deals with combinations of signals in which each signal has a known value and a single strength level.

If two or more signals of unequal strength combine in a wired net configuration, the stronger signal shall dominate all the weaker drivers and determine the result. The combination of two or more signals of like value shall result in the same value with the greater of all the strengths. The combination of signals identical in strength and value shall result in the same signal.

The combination of signals with unlike values and the same strength can have three possible results. Two of the results occur in the presence of wired logic, and the third occurs in its absence. Wired logic is discussed in [28.12.4](#). The result in the absence of wired logic is the subject of [Figure 28-4](#) (in [28.12.2](#)).

In [Figure 28-3](#), the numbers in parentheses indicate the relative strengths of the signals. The combination of a **pu111** and a **strong0** results in a **strong0**, which is the stronger of the two signals.

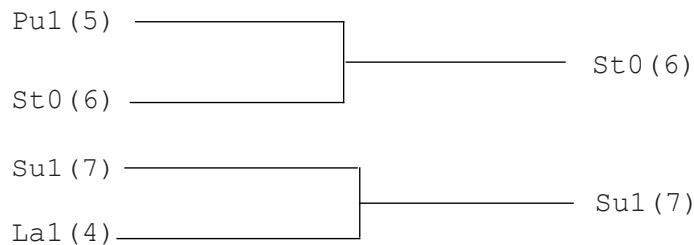

Figure 28-3—Combining unequal strengths

28.12.2 Ambiguous strengths: sources and combinations

There are several classifications of signals possessing ambiguous strengths, as follows:

- Signals with known values and multiple strength levels
- Signals with a value x , which have strength levels consisting of subdivisions of both the *strength1* and the *strength0* parts of the scale of strengths in [Figure 28-2](#)
- Signals with a value L , which have strength levels that consist of high impedance joined with strength levels in the *strength0* part of the scale of strengths in [Figure 28-2](#)
- Signals with a value H , which have strength levels that consist of high impedance joined with strength levels in the *strength1* part of the scale of strengths in [Figure 28-2](#)

Many configurations can produce signals of ambiguous strength. When two signals of equal strength and opposite value combine, the result shall be a value x , along with the strength levels of both signals and all the smaller strength levels.

[Figure 28-4](#) shows the combination of a **weak** signal with a value 1 and a **weak** signal with a value 0 yielding a signal with **weak** strength and a value x .

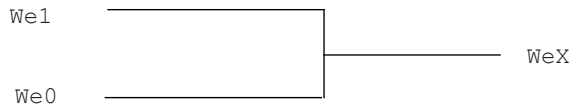

Figure 28-4—Combination of signals of equal strength and opposite values

This output signal is described in [Figure 28-5](#).

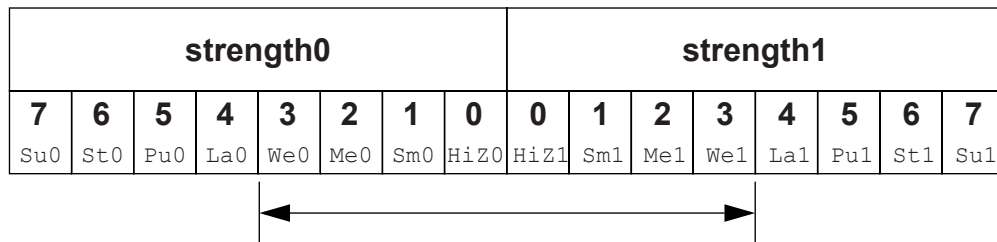

Figure 28-5—Weak x signal strength

An ambiguous signal strength can be a range of possible values. An example is the strength of the output from the three-state drivers with unknown control inputs as shown in [Figure 28-6](#).

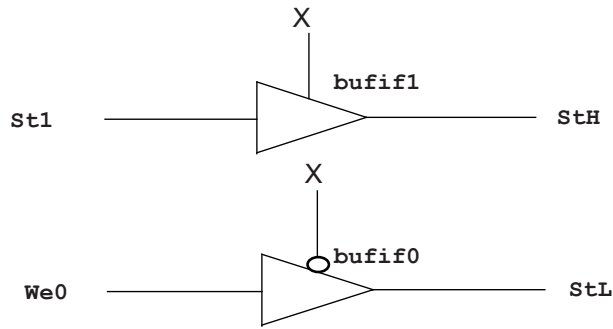

Figure 28-6—Bufifs with control inputs of x

The output of the **bufif1** in [Figure 28-6](#) is a **strong H**, composed of the range of values described in [Figure 28-7](#).

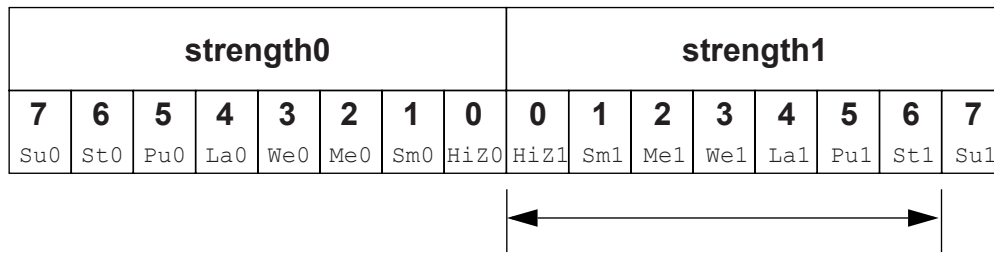

Figure 28-7—Strong H range of values

The output of the **bufif0** in [Figure 28-6](#) is a **strong L**, composed of the range of values described in [Figure 28-8](#).

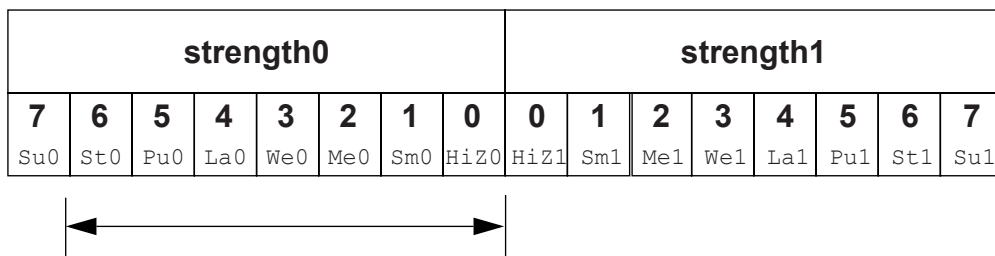

Figure 28-8—Strong L range of values

The combination of two signals of ambiguous strength shall result in a signal of ambiguous strength. The resulting signal shall have a range of strength levels that includes the strength levels in its component signals. The combination of outputs from two three-state drivers with unknown control inputs, shown in [Figure 28-9](#), is an example.

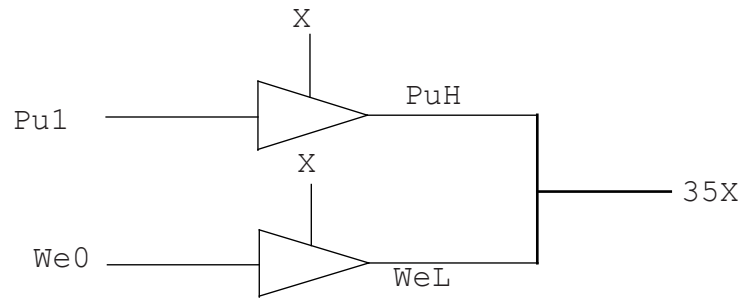

Figure 28-9—Combined signals of ambiguous strength

In [Figure 28-9](#), the combination of signals of ambiguous strengths produces a range that includes the extremes of the signals and all the strengths between them, as described in [Figure 28-10](#).

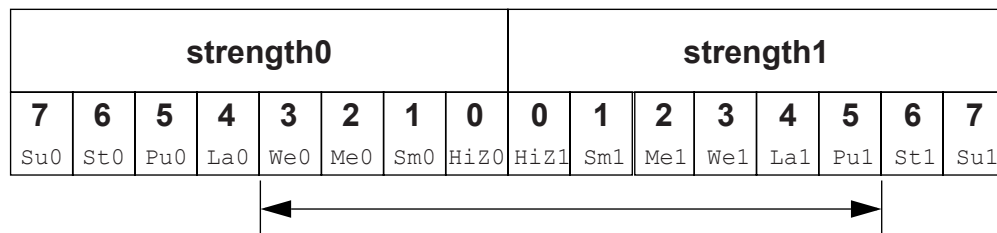

Figure 28-10—Range of strengths for an unknown signal

The result is a value x because its range includes the values 1 and 0. The number 35, which precedes the x , is a concatenation of two digits. The first is the digit 3, which corresponds to the highest *strength0* level for the result. The second digit, 5, corresponds to the highest *strength1* level for the result.

Switch networks can produce a ranges of strengths of the same value, such as the signals from the upper and lower configurations in [Figure 28-11](#).

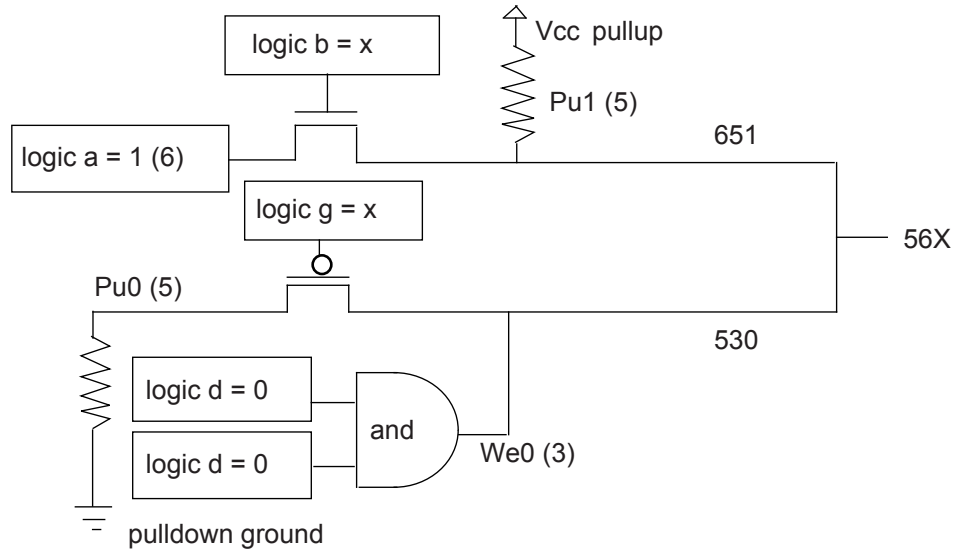

Figure 28-11—Ambiguous strengths from switch networks

In [Figure 28-11](#), the upper combination of a `logic` type, a gate controlled by a `logic` type of unspecified value, and a pullup produces a signal with a value of 1 and a range of strengths (651) described in [Figure 28-12](#).

strength0								strength1							
7	6	5	4	3	2	1	0	0	1	2	3	4	5	6	7
Su0	St0	Pu0	La0	We0	Me0	Sm0	HiZ0	HiZ1	Sm1	Me1	We1	La1	Pu1	St1	Su1

Figure 28-12—Range of two strengths of a defined value

In [Figure 28-11](#), the lower combination of a `pulldown`, a gate controlled by a `logic` type of unspecified value, and an `and` gate produces a signal with a value 0 and a range of strengths (530) described in [Figure 28-13](#).

strength0								strength1							
7	6	5	4	3	2	1	0	0	1	2	3	4	5	6	7
Su0	St0	Pu0	La0	We0	Me0	Sm0	HiZ0	HiZ1	Sm1	Me1	We1	La1	Pu1	St1	Su1

Figure 28-13—Range of three strengths of a defined value

When the signals from the upper and lower configurations in [Figure 28-11](#) combine, the result is an unknown with a range (56x) determined by the extremes of the two signals shown in [Figure 28-14](#).

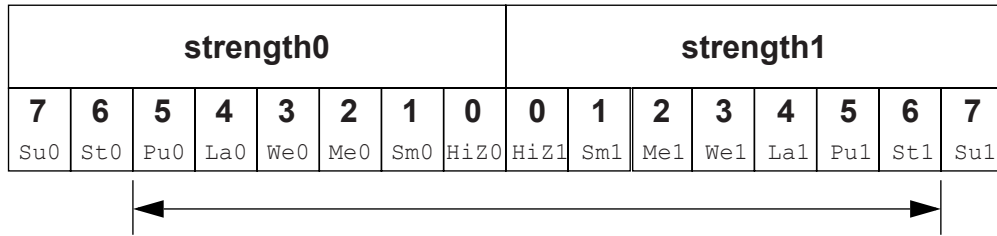

Figure 28-14—Unknown value with a range of strengths

In [Figure 28-11](#), replacing the **pull**down in the lower configuration with a **supply0** would change the range of the result to the range (stx) described in [Figure 28-15](#).

The range in [Figure 28-15](#) is **strong** x because it is unknown and the extremes of both its components are **strong**. The extreme of the output of the lower configuration is **strong** because the lower **pmos** reduces the strength of the **supply0** signal. This modeling feature is discussed in [28.13](#).

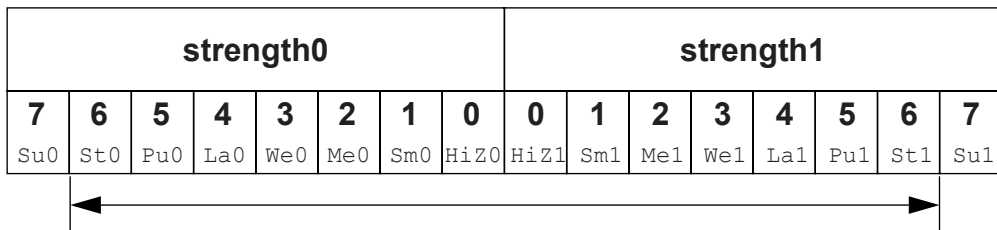

Figure 28-15—Strong X range

Logic gates produce results with ambiguous strengths as well as three-state drivers. Such a case appears in [Figure 28-16](#). The **and** gate N1 is declared with **highz0** strength, and N2 is declared with **weak0** strength.

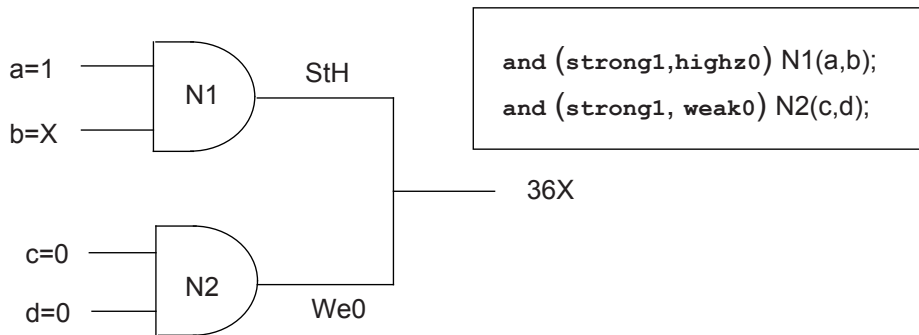

Figure 28-16—Ambiguous strength from gates

In [Figure 28-16](#), **logic** type **b** has an unspecified value; therefore, input to the upper **and** gate is **strong** x . The upper **and** gate has a strength specification including **highz0**. The signal from the upper **and** gate is a **strong** **H** composed of the values as described in [Figure 28-17](#).

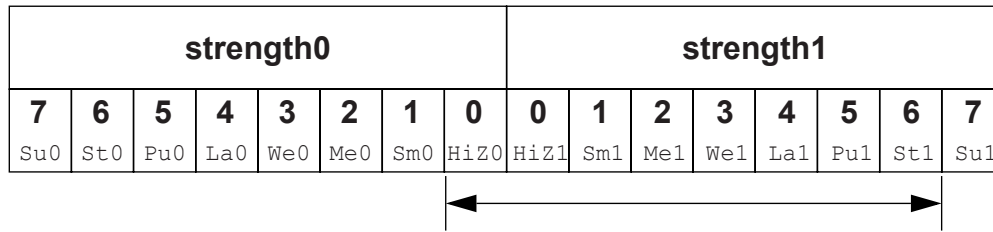

Figure 28-17—Ambiguous strength signal from a gate

HiZ0 is part of the result because the strength specification for the gate in question specified that strength for an output with a value 0. A strength specification other than high impedance for the 0 value output results in a gate output value x . The output of the lower **and** gate is a **weak** 0 as described in [Figure 28-18](#).

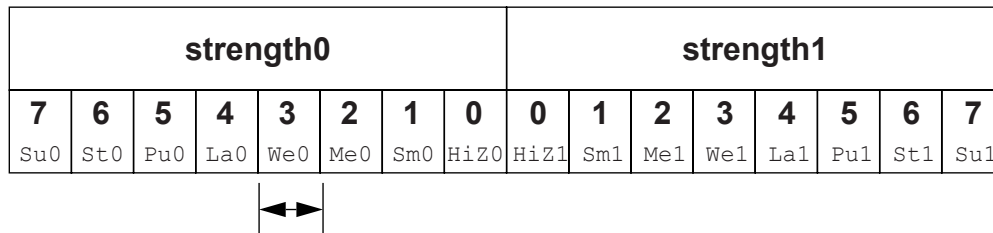

Figure 28-18—Weak 0

When the signals combine, the result is the range (36 x) as described in [Figure 28-19](#).

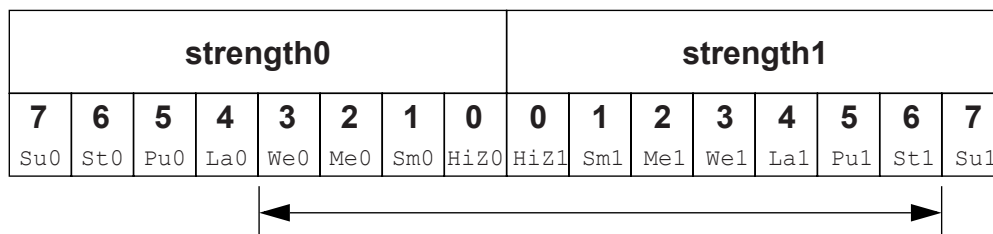

Figure 28-19—Ambiguous strength in combined gate signals

[Figure 28-19](#) presents the combination of an ambiguous signal and an unambiguous signal. Such combinations are the topic of [28.12.3](#).

28.12.3 Ambiguous strength signals and unambiguous signals

The combination of a signal with unambiguous strength and known value with another signal of ambiguous strength presents several possible cases. To understand a set of rules governing this type of combination, it is necessary to consider the strength levels of the ambiguous strength signal separately from each other and relative to the unambiguous strength signal. When a signal of known value and unambiguous strength combines with a component of a signal of ambiguous strength, the rules shall be as follows:

- a) The strength levels of the ambiguous strength signal that are greater than the strength level of the unambiguous signal shall remain in the result.
- b) The strength levels of the ambiguous strength signal that are smaller than or equal to the strength level of the unambiguous signal shall disappear from the result, subject to rule c).
- c) If the operation of rule a) and rule b) results in a gap in strength levels because the signals are of opposite value, the signals in the gap shall be part of the result.

The following figures show some applications of the rules.

In [Figure 28-20](#), the strength levels in the ambiguous strength signal that are smaller than or equal to the strength level of the unambiguous signal disappear from the result, demonstrating rule b).

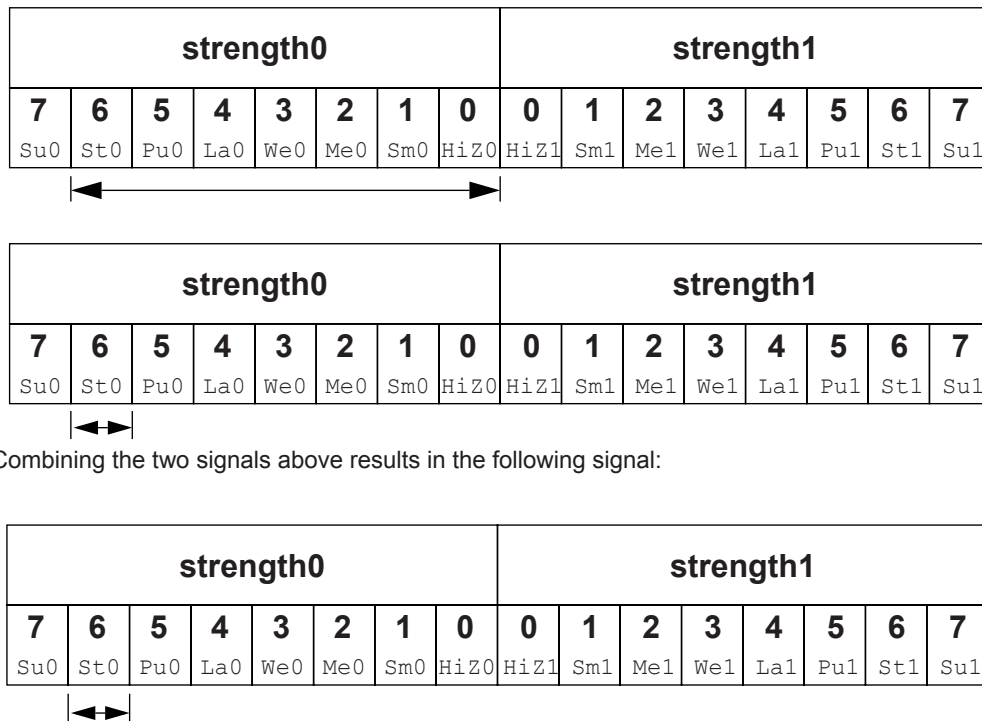
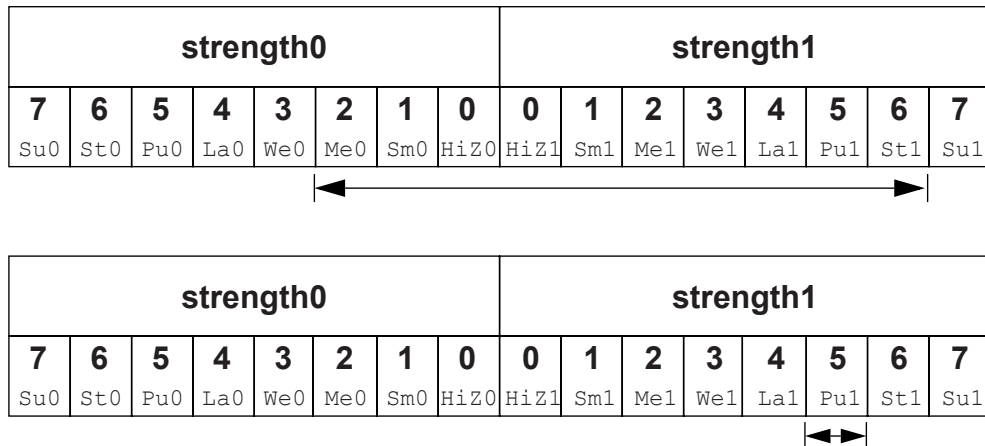

Figure 28-20—Elimination of strength levels

In [Figure 28-21](#), rule a), rule b), and rule c) apply. The strength levels of the ambiguous strength signal that are of opposite value and lesser strength than the unambiguous strength signal disappear from the result. The strength levels in the ambiguous strength signal that are less than the strength level of the unambiguous strength signal, and of the same value, disappear from the result. The strength level of the unambiguous strength signal and the greater extreme of the ambiguous strength signal define a range in the result.



Combining the two signals above results in the following signal:

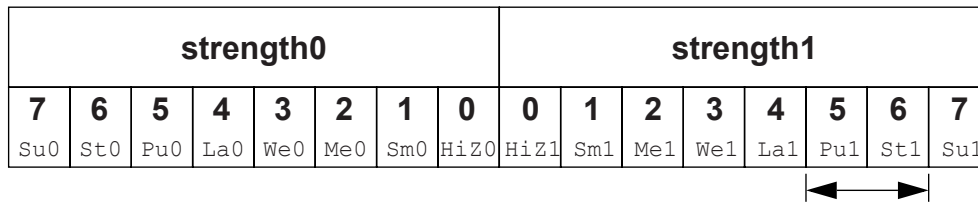
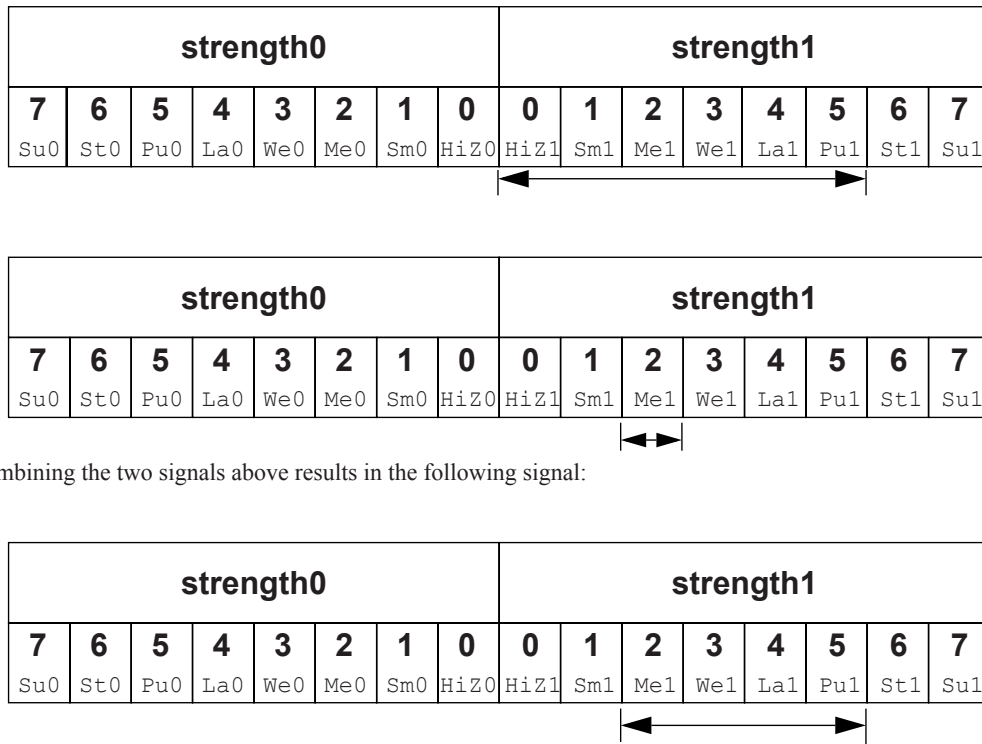

Figure 28-21—Result showing a range and the elimination of strength levels of two values

In [Figure 28-22](#), rule a) and rule b) apply. The strength levels in the ambiguous strength signal that are less than the strength level of the unambiguous strength signal disappear from the result. The strength level of the unambiguous strength signal and the strength level at the greater extreme of the ambiguous strength signal define a range in the result.



Combining the two signals above results in the following signal:

Figure 28-22—Result showing a range and the elimination of strength levels of one value

In [Figure 28-23](#), rule a), rule b), and rule c) apply. The greater extreme of the range of strengths for the ambiguous strength signal is larger than the strength level of the unambiguous strength signal. The result is a range defined by the greatest strength in the range of the ambiguous strength signal and by the strength level of the unambiguous strength signal.

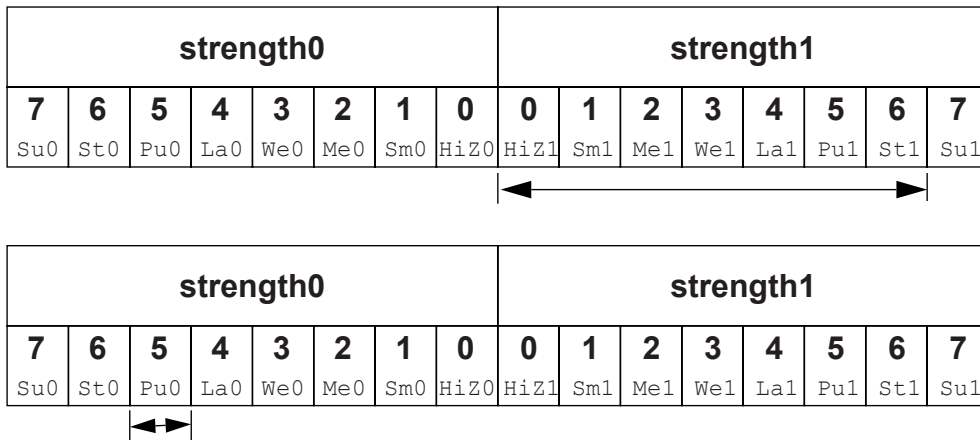

Combining the two signals above results in the following signal:

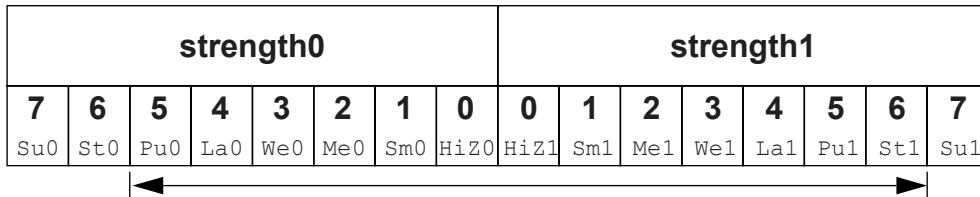
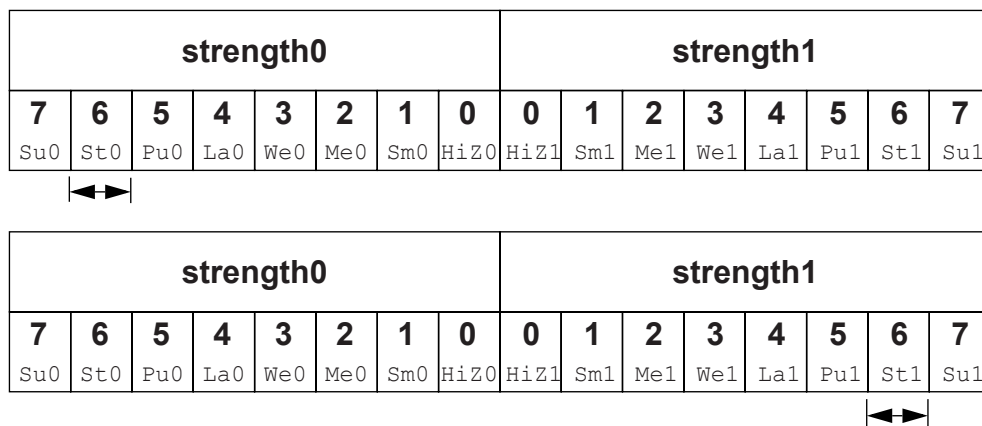

Figure 28-23—A range of both values

28.12.4 Wired logic net types

The net types `triand`, `wand`, `trior`, and `wor` shall resolve conflicts when multiple drivers have the same strength. These net types shall resolve signal values by treating signals as inputs of logic functions.

Consider the combination of two signals of unambiguous strength in [Figure 28-24](#).



```
wired AND logic value result: 0
wired OR  logic value result: 1
```

Figure 28-24—Wired logic with unambiguous strength signals

The combination of the signals in [Figure 28-24](#), using *wired and* logic, produces a result with the same value as the result produced by an **and** gate with the value of the two signals as its inputs. The combination of signals using *wired or* logic produces a result with the same value as the result produced by an **or** gate with the values of the two signals as its inputs. The strength of the result is the same as the strength of the combined signals in both cases. If the value of the upper signal changes so that both signals in [Figure 28-24](#) possess a value 1, then the results of both types of logic have a value 1.

When ambiguous strength signals combine in wired logic, it is necessary to consider the results of all combinations of each of the strength levels in the first signal with each of the strength levels in the second signal, as shown in [Figure 28-25](#).

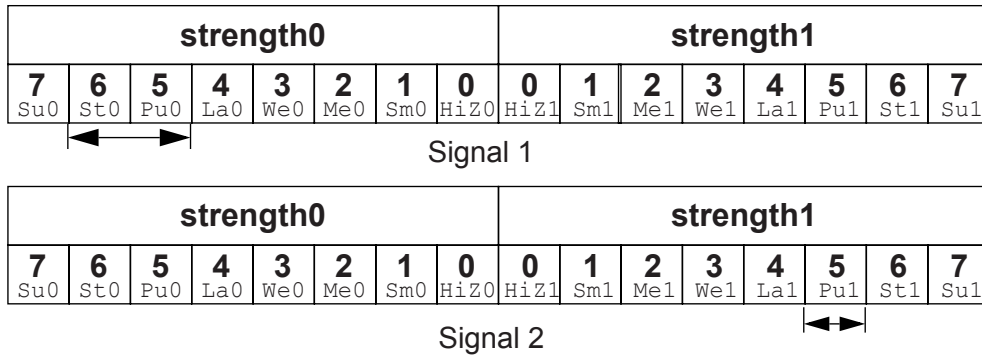

The combinations of strength levels for *and* logic appear in the following chart:

signal1		signal2		result	
strength	value	strength	value	strength	value
5	0	5	1	5	0
6	0	5	1	6	0

The result is the following signal:

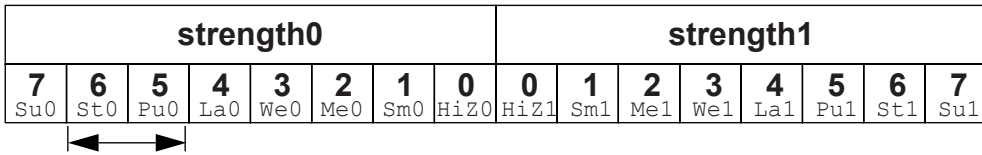

The combinations of strength levels for *or* logic appear in the following chart:

signal1		signal2		result	
strength	value	strength	value	strength	value
5	0	5	1	5	1
6	0	5	1	6	0

The result is the following signal:

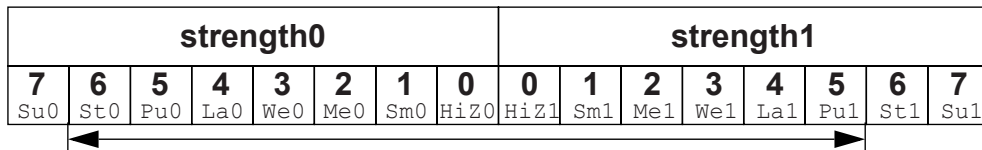

Figure 28-25—Wired logic and ambiguous strengths

28.13 Strength reduction by nonresistive devices

The **nmos**, **pmos**, and **cmos** switches shall pass the strength from the data input to the output, except that a **supply** strength shall be reduced to a **strong** strength.

The **tran**, **tranif0**, and **tranif1** switches shall not affect signal strength across the bidirectional terminals, except that a **supply** strength shall be reduced to a **strong** strength.

28.14 Strength reduction by resistive devices

The **rnmos**, **rpmos**, **rcmos**, **rtran**, **rtranif1**, and **rtranif0** devices shall reduce the strength of signals that pass through them according to [Table 28-8](#).

Table 28-8—Strength reduction rules

Input strength	Reduced strength
Supply drive	Pull drive
Strong drive	Pull drive
Pull drive	Weak drive
Large capacitor	Medium capacitor
Weak drive	Medium capacitor
Medium capacitor	Small capacitor
Small capacitor	Small capacitor
High impedance	High impedance

28.15 Strengths of net types

The **tri0**, **tri1**, **supply0**, and **supply1** net types shall generate signals with specific strength levels. The **triereg** declaration can specify either of two signal strength levels other than a default strength level.

28.15.1 tri0 and tri1 net strengths

The **tri0** net type models a net connected to a resistive **pulldown** device. In the absence of an overriding source, such a signal shall have a value 0 and a **pull** strength. The **tri1** net type models a net connected to a resistive **pullup** device. In the absence of an overriding source, such a signal shall have a value 1 and a **pull** strength.

28.15.2 triereg strength

The **triereg** net type models charge storage nodes. The strength of the drive resulting from a **triereg** net that is in the charge storage state (that is, a driver charged the net and then went to high impedance) shall be one of these three strengths: **large**, **medium**, or **small**. The specific strength associated with a particular **triereg** net shall be specified by the user in the net declaration. The default shall be **medium**. The syntax of this specification is described in [6.7](#).

28.15.3 supply0 and supply1 net strengths

The **supply0** net type models ground connections. The **supply1** net type models connections to power supplies. The **supply0** and **supply1** net types shall have **supply** driving strengths.

28.16 Gate and net delays

Gate and net delays provide a means of more accurately describing delays through a circuit. The *gate delays* specify the signal propagation delay from any gate input to the gate output. Up to three values per output representing rise, fall, and turn-off delays can be specified (see [28.4](#) through [28.9](#)).

Net delays refer to the time it takes from any driver on the net changing value to the time when the net value is updated and propagated further. Up to three delay values per net can be specified.

For both gates and nets, the *default delay* shall be zero when no delay specification is given. When one delay value is given, then this value shall be used for all propagation delays associated with the gate or the net. When two delays are given, the first delay shall specify the rise delay, and the second delay shall specify the fall delay. The delay when the signal changes to high impedance or to unknown shall be the lesser of the two delay values.

For a three-delay specification

- The first delay refers to the transition to the 1 value (rise delay).
- The second delay refers to the transition to the 0 value (fall delay).
- The third delay refers to the transition to the high-impedance value.

When a value changes to the unknown (x) value, the delay is the smallest of the three delays. The strength of the input signal shall not affect the propagation delay from an input to an output.

[Table 28-9](#) summarizes the from-to propagation delay choice for the two- and three-delay specifications.

Table 28-9—Rules for propagation delays

From value:	To value:	Delay used if there are	
		2 delays	3 delays
0	1	d1	d1
0	x	min(d1, d2)	min(d1, d2, d3)
0	z	min(d1, d2)	d3
1	0	d2	d2
1	x	min(d1, d2)	min(d1, d2, d3)
1	z	min(d1, d2)	d3
x	0	d2	d2
x	1	d1	d1
x	z	min(d1, d2)	d3
z	0	d2	d2

Table 28-9—Rules for propagation delays (continued)

From value:	To value:	Delay used if there are	
		2 delays	3 delays
z	1	d1	d1
z	x	min(d1, d2)	min(d1, d2, d3)

Example 1—The following is an example of a delay specification with one, two, and three delays:

```
and #(10) a1 (out, in1, in2);           // only one delay
and #(10,12) a2 (out, in1, in2);       // rise and fall delays
bufif0 #(10,12,11) b3 (out, in, ctrl); // rise, fall, and turn-off delays
```

Example 2—The following example specifies a simple latch module with three-state outputs, where individual delays are given to the gates. The propagation delay from the inputs to the outputs of the module will be cumulative, and it depends on the signal path through the network.

```
module tri_latch (qout, nqout, clock, data, enable);
  output qout, nqout;
  input clock, data, enable;
  tri qout, nqout;

  not #5 n1 (ndata, data);
  nand #(3,5) n2 (wa, data, clock),
  n3 (wb, ndata, clock);
  nand #(12,15) n4 (q, nq, wa),
  n5 (nq, q, wb);
  bufif1 #(3,7,13) q_drive (qout, q, enable),
  nq_drive (nqout, nq, enable);

endmodule
```

28.16.1 min:typ:max delays

The syntax for delays on gate primitives (including UDPs; see [Clause 29](#)), nets, and continuous assignments shall allow three values each for the rising, falling, and turn-off delays. The minimum, typical, and maximum values for each delay shall be specified as expressions separated by colons. There shall be no required relation (e.g., $\text{min} \leq \text{typ} \leq \text{max}$) between the expressions for minimum, typical, and maximum delays. These can be any three expressions.

The following example shows min:typ:max values for rising, falling, and turn-off delays:

```
module iobuf (io1, io2, dir);
  . . .
  bufif0 #(5:7:9, 8:10:12, 15:18:21) b1 (io1, io2, dir);
  bufif1 #(6:8:10, 5:7:9, 13:17:19) b2 (io2, io1, dir);
  . . .
endmodule
```

The syntax for delay controls in procedural statements (see [9.4](#)) also allows minimum, typical, and maximum values. These are specified by expressions separated by colons. The following example illustrates this concept:

```

parameter min_hi = 97, typ_hi = 100, max_hi = 107;
logic clk;

always begin
    #(95:100:105) clk = 1;
    #(min_hi:typ_hi:max_hi) clk = 0;
end

```

28.16.2 trireg net charge decay

Like all nets, the delay specification in a **trireg** net declaration can contain up to three delays. The first two delays shall specify the delay for transition to the 1 and 0 logic states when the **trireg** net is driven to these states by a driver. The third delay shall specify the *charge decay time* instead of the delay in a transition to the z logic state. The charge decay time specifies the delay between when the drivers of a **trireg** net turn off and when its stored charge can no longer be determined.

A **trireg** net does not need a turn-off delay specification because a **trireg** net never makes a transition to the z logic state. When the drivers of a **trireg** net make transitions from the 1, 0, or x logic states to off, the **trireg** net shall retain the previous 1, 0, or x logic state that was on its drivers. The z value shall not propagate from the drivers of a **trireg** net to a **trireg** net. A **trireg** net can only hold a z logic state when z is the initial logic state of the **trireg** net or when the **trireg** net is forced to the z state with a **force** statement (see [10.6.2](#)).

A delay specification for charge decay models a charge storage node that is not ideal, i.e., a charge storage node whose charge leaks out through its surrounding devices and connections.

The charge decay process and the delay specification for charge decay are described in [28.16.2.1](#) and [28.16.2.2](#), respectively.

28.16.2.1 Charge decay process

Charge decay is the cause of transition of a 1 or 0 that is stored in a **trireg** net to an unknown value (x) after a specified delay. The charge decay process shall begin when the drivers of the **trireg** net turn off and the **trireg** net starts to hold charge. The charge decay process shall end under the following two conditions:

- a) The delay specified by charge decay time elapses, and the **trireg** net makes a transition from 1 or 0 to x.
- b) The drivers of **trireg** net turn on and propagate a 1, 0, or x into the **trireg** net.

28.16.2.2 Delay specification for charge decay time

The third delay in a **trireg** net declaration shall specify the charge decay time. A three-valued delay specification in a **trireg** net declaration shall have the following form:

```
#(d1, d2, d3) // (rise_delay, fall_delay, charge_decay_time)
```

The charge decay time specification in a **trireg** net declaration shall be preceded by a rise and a fall delay specification.

Example 1—The following example shows a specification of the charge decay time in a **trireg** net declaration:

```
trireg (large) #(0,0,50) cap1;
```

This example declares a **trireg** net named `cap1`. This **trireg** net stores a **large** charge. The delay specifications for the rise delay is 0, the fall delay is 0, and the charge decay time specification is 50 time units.

Example 2—The next example presents a source description file that contains a **trireg** net declaration with a charge decay time specification. [Figure 28-26](#) shows an equivalent schematic for the source description.

```
module capacitor;
  logic data, gate;

  // trireg declaration with a charge decay time of 50 time units
  trireg (large) #(0,0,50) cap1;

  nmos nmos1 (cap1, data, gate); // nmos that drives the trireg

  initial begin
    $monitor("%0d data=%v gate=%v cap1=%v", $time, data, gate, cap1);
    data = 1;
    // Toggle the driver of the control input to the nmos switch
    gate = 1;
    #10 gate = 0;
    #30 gate = 1;
    #10 gate = 0;
    #100 $finish;
  end
endmodule
```

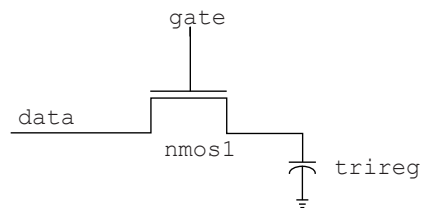

Figure 28-26—Trireg net with capacitance

29. User defined primitives (UDPs)

29.1 General

This clause describes the following:

- UDP definitions
- Combinational UDPs
- Level-sensitive sequential UDPs
- Edge-sensitive sequential UDPs
- Sequential UDP initialization
- UDP instantiation

29.2 Overview

This clause describes a modeling technique to augment the set of predefined gate primitives by designing and specifying new primitive elements called UDPs. Instances of these new UDPs can be used in exactly the same manner as the gate primitives to represent the circuit being modeled.

The following two types of behavior can be represented in a UDP:

- a) Combinational—modeled by a *combinational UDP*
- b) Sequential—modeled by a *sequential UDP*

A combinational UDP uses the value of its inputs to determine the next value of its output. A sequential UDP uses the value of its inputs and the current value of its output to determine the value of its output. Sequential UDPs provide a way to model sequential circuits such as flip-flops and latches. A sequential UDP can model both level-sensitive and edge-sensitive behavior.

Each UDP has exactly one output, which can be in one of three states: 0, 1, or x. The three-state value z is not supported. In sequential UDPs, the output always has the same value as the internal state.

The z values passed to UDP inputs shall be treated the same as x values.

29.3 UDP definition

UDP definitions are independent of modules; they are at the same level as module definitions in the syntax hierarchy. They can appear anywhere in the source text, either before or after they are instantiated inside a module. They shall not appear between the keywords `module...endmodule`, `program...endprogram`, `interface...endinterface`, or `package...endpackage`.

Implementations may limit the maximum number of UDP definitions in a model, but they shall allow at least 256.

The formal syntax of the UDP definition is given in [Syntax 29-1](#).

```

udp_nonansi_declaration ::=
    { attribute_instance } primitive udp_identifier ( udp_port_list ) ;
                                                                    //from A.5.1
udp_ansi_declaration ::=
    { attribute_instance } primitive udp_identifier ( udp_declaration_port_list ) ;

```

```

udp_declaration ::=
  udp_nonansi_declaration udp_port_declaration { udp_port_declaration }
  udp_body
  endprimitive [ : udp_identifier ]
| udp_ansi_declaration
  udp_body
  endprimitive [ : udp_identifier ]
| extern udp_nonansi_declaration
| extern udp_ansi_declaration
| { attribute_instance } primitive udp_identifier ( .* ) ;
  { udp_port_declaration }
  udp_body
  endprimitive [ : udp_identifier ]

udp_port_list ::= output_port_identifier , input_port_identifier { , input_port_identifier } //from A.5.2
udp_declaration_port_list ::= udp_output_declaration , udp_input_declaration { , udp_input_declaration }
udp_port_declaration ::=
  udp_output_declaration ;
| udp_input_declaration ;
| udp_reg_declaration ;

udp_output_declaration ::=
  { attribute_instance } output port_identifier
| { attribute_instance } output reg port_identifier [ = constant_expression ]

udp_input_declaration ::= { attribute_instance } input list_of_udp_port_identifiers
udp_reg_declaration ::= { attribute_instance } reg variable_identifier //from A.5.3
udp_body ::= combinational_body | sequential_body
combinational_body ::= table combinational_entry { combinational_entry } endtable
combinational_entry ::= level_input_list : output_symbol ;
sequential_body ::= [ udp_initial_statement ] table sequential_entry { sequential_entry } endtable
udp_initial_statement ::= initial output_port_identifier = init_val ;
init_val ::= 1'b0 | 1'b1 | 1'bx | 1'bX | 1'B0 | 1'B1 | 1'Bx | 1'BX | 1 | 0
sequential_entry ::= seq_input_list : current_state : next_state ;
seq_input_list ::= level_input_list | edge_input_list
level_input_list ::= level_symbol { level_symbol }
edge_input_list ::= { level_symbol } edge_indicator { level_symbol }
edge_indicator ::= ( level_symbol level_symbol ) | edge_symbol
current_state ::= level_symbol
next_state ::= output_symbol | -
output_symbol ::= 0 | 1 | x | X
level_symbol ::= 0 | 1 | x | X | ? | b | B
edge_symbol ::= r | R | f | F | p | P | n | N | *

udp_instantiation ::=
  udp_identifier [ drive_strength ] [ delay2 ] udp_instance { , udp_instance } ; //from A.5.4
udp_instance ::= [ name_of_instance ] ( output_terminal , input_terminal { , input_terminal } )

```

Syntax 29-1—Syntax for UDPs (excerpt from [Annex A](#))

29.3.1 UDP header

A UDP definition shall have one of two alternate forms. The first form, *udp_nonansi_declaration*, shall begin with the keyword **primitive**, followed by an identifier, which shall be the name of the UDP. This in turn shall be followed by a comma-separated list of port names enclosed in parentheses, which shall be followed by a semicolon. The UDP definition header shall be followed by port declarations and a state table. The UDP definition shall be terminated by the keyword **endprimitive**.

The second form, *udp_ansi_declaration*, shall begin with the keyword **primitive**, followed by an identifier, which shall be the name of the UDP. This in turn shall be followed by a comma-separated list of port declarations enclosed in parentheses, followed by a semicolon. The UDP definition header shall be followed by a state table. The UDP definition shall be terminated by the keyword **endprimitive**.

UDPs have multiple input ports and exactly one output port; bidirectional inout ports are not permitted on UDPs. All ports of a UDP shall be scalar; vector ports are not permitted.

The output port shall be the first port in the port list.

29.3.2 UDP port declarations

UDPs shall contain input and output port declarations. The output port declaration begins with the keyword **output**, followed by one output port name. The input port declaration begins with the keyword **input**, followed by one or more input port names.

Sequential UDPs shall contain a **reg** declaration for the output port, either in addition to the output declaration, when the UDP is declared using the first form of a UDP Header, or as part of the output declaration. Combinational UDPs cannot contain a **reg** declaration. The initial value of the output port can be specified in an **initial** statement in a sequential UDP (see [29.3.3](#)).

Implementations may limit the maximum number of inputs to a UDP, but they shall allow at least nine inputs for sequential UDPs and 10 inputs for combinational UDPs.

When UDPs are discussed from the instantiation point of view, UDP ports are referred to as terminals. This is because they are consistent with terminals of other primitives, rather than module ports. Wherever primitive terminals are mentioned, the text shall also apply to UDP terminals.

29.3.3 Sequential UDP initial statement

The sequential UDP initial statement specifies the value of the output port when simulation begins. This statement begins with the keyword **initial**. The statement that follows shall be an assignment statement that assigns a single-bit literal value to the output port.

29.3.4 UDP state table

The state table defines the behavior of a UDP. It begins with the keyword **table** and is terminated with the keyword **endtable**. Each row of the table is terminated by a semicolon.

Each row of the table is created using a variety of characters (see [Table 29-1](#)), which indicate input values and output state. Three states—0, 1, and x—are supported. The z state is explicitly excluded from consideration in UDPs. A number of special characters are defined to represent certain combinations of state possibilities. These are described in [Table 29-1](#).

The order of the input state fields of each row of the state table is taken directly from the port list in the UDP definition header. It is not related to the order of the input port declarations.

Combinational UDPs have one field per input and one field for the output. The input fields are separated from the output field by a colon (:). Each row defines the output for a particular combination of the input values (see [29.4](#)).

Sequential UDPs have an additional field inserted between the input fields and the output field. This additional field represents the current state of the UDP and is considered equivalent to the current output value. It is delimited by colons. Each row defines the output based on the current state, particular combinations of input values, and at most one input transition (see [29.6](#)). A row such as the one shown below is illegal:

(01) (10) 0 : 0 : 1 ;

If all input values are specified as x, then the output state shall be specified as x.

It is not necessary to explicitly specify every possible input combination. All combinations of input values that are not explicitly specified result in a default output state of x.

It shall be illegal to have the same combination of inputs, including edges, specify different output values.

29.3.5 Z values in UDP

The z value in a table entry is not supported, and it is considered illegal. The z values passed to UDP inputs shall be treated the same as x values.

29.3.6 Summary of symbols

To improve the readability and to ease writing of the state table, several special symbols are provided. [Table 29-1](#) summarizes the meaning of all the value symbols that are valid in the table part of a UDP definition.

Table 29-1—UDP table symbols

Symbol	Interpretation	Comments
0	Logic 0	
1	Logic 1	
x	Unknown	Permitted in the input and output fields of all UDPs and in the current state field of sequential UDPs.
?	Iteration of 0, 1, and x	Not permitted in output field.
b	Iteration of 0 and 1	Permitted in the input fields of all UDPs and in the current state field of sequential UDPs. Not permitted in the output field.
-	No change	Permitted only in the output field of a sequential UDP.
(vw)	Value change from v to w	v and w can be any one of 0, 1, x, ?, or b, and are only permitted in the input field.
*	Same as (??)	Any value change on input.
r	Same as (01)	Rising edge on input.
f	Same as (10)	Falling edge on input.

Table 29-1—UDP table symbols (continued)

Symbol	Interpretation	Comments
p	Iteration of (01), (0x) and (x1)	Potential positive edge on the input.
n	Iteration of (10), (1x) and (x0)	Potential negative edge on the input.

29.4 Combinational UDPs

In combinational UDPs, the output state is determined solely as a function of the current input states. Whenever an input state changes, the UDP is evaluated and the output state is set to the value indicated by the row in the state table that matches all the input states. All combinations of the inputs that are not explicitly specified will drive the output state to the unknown value x.

The following example defines a multiplexer with two data inputs and a control input:

```
primitive multiplexer (mux, control, dataA, dataB);
  output mux;
  input control, dataA, dataB;
  table
    // control  dataA  dataB  mux
        0      1      0      :  1 ;
        0      1      1      :  1 ;
        0      1      x      :  1 ;
        0      0      0      :  0 ;
        0      0      1      :  0 ;
        0      0      x      :  0 ;
        1      0      1      :  1 ;
        1      1      1      :  1 ;
        1      x      1      :  1 ;
        1      0      0      :  0 ;
        1      1      0      :  0 ;
        1      x      0      :  0 ;
        x      0      0      :  0 ;
        x      1      1      :  1 ;
  endtable
endprimitive
```

The first entry in this example can be explained as follows: when `control` equals 0, `dataA` equals 1, and `dataB` equals 0, then output `mux` equals 1.

The input combination 0xx (`control=0`, `dataA=x`, `dataB=x`) is not specified. If this combination occurs during simulation, the value of output port `mux` will become x.

Using `?`, the description of a multiplexer can be abbreviated as follows:

```
primitive multiplexer (mux, control, dataA, dataB);
  output mux;
  input control, dataA, dataB;
  table
    // control  dataA  dataB  mux
        0      1      ?      :  1 ;      // ? = 0 1 x
        0      0      ?      :  0 ;
        1      ?      1      :  1 ;
        1      ?      0      :  0 ;
        x      0      0      :  0 ;
```



```

        x      1      1      : 1 ;
    endtable
endprimitive

```

29.5 Level-sensitive sequential UDPs

Level-sensitive sequential behavior is represented the same way as combinational behavior, except that the output is declared to be of type **reg** and there is an additional field in each table entry. This new field represents the current state of the UDP. The output field in a sequential UDP represents the next state.

Consider the example of a latch:

```

primitive latch (q, ena_, data);
    output q; reg q;
    input ena_, data;
    table
    // ena_ data : q : q+
        0      1      : ? : 1 ;
        0      0      : ? : 0 ;
        1      ?      : ? : - ; // - = no change
    endtable
endprimitive

```

This description differs from a combinational UDP model in two ways. First, the output identifier *q* has an additional **reg** declaration to indicate that there is an internal state *q*. The output value of the UDP is always the same as the internal state. Second, a field for the current state, which is separated by colons from the inputs and the output, has been added.

29.6 Edge-sensitive sequential UDPs

In level-sensitive behavior, the values of the inputs and the current state are sufficient to determine the output value. Edge-sensitive behavior differs in that changes in the output are triggered by specific transitions of the inputs. This makes the state table a transition table.

Each table entry can have a transition specification on at most one input. A transition is specified by a pair of values in parentheses such as (01) or a transition symbol such as *r*. Entries such as the following are illegal:

```
(01)(01)0 : 0 : 1 ;
```

All transitions that do not affect the output shall be explicitly specified. Otherwise, such transitions cause the value of the output to change to *x*. All unspecified transitions default to the output value *x*.

If the behavior of the UDP is sensitive to edges of any input, the desired output state shall be specified for all edges of all inputs.

The following example describes a rising edge D flip-flop:

```

primitive d_edge_ff (q, clock, data);
    output q; reg q;
    input clock, data;

    table
    // clock data q q+
    // obtain output on rising edge of clock

```

```
(01)  0    :  ?  :  0  ;
(01)  1    :  ?  :  1  ;
(0?)  1    :  1  :  1  ;
(0?)  0    :  0  :  0  ;
// ignore negative edge of clock
(?0)  ?    :  ?  :  -  ;
// ignore data changes on steady clock
?     (??) :  ?  :  -  ;
endtable
endprimitive
```

The terms such as (01) represent transitions of the input values. Specifically, (01) represents a transition from 0 to 1. The first line in the table of the preceding UDP definition is interpreted as follows: when clock changes value from 0 to 1 and data equals 0, the output goes to 0 no matter what the current state.

The transition of clock from 0 to x with data equal to 0 and current state equal to 1 will result in the output q going to x.

29.7 Sequential UDP initialization

The initial value on the output port of a sequential UDP can be specified with an initial statement that provides a procedural assignment. The initial statement is optional.

Like initial statements in modules, the initial statement in UDPs begins with the keyword **initial**. The valid contents of initial statements in UDPs and the valid left-hand and right-hand sides of their procedural assignment statements differ from initial statements in modules. A partial list of differences between these two types of initial statements is described in [Table 29-2](#).

Table 29-2—Initial statements in UDPs and modules

Initial statements in UDPs	Initial statements in modules
Contents limited to one procedural assignment statement	Contents can be one procedural statement of any type or a block statement that contains more than one procedural statement
The procedural assignment statement shall assign a value to a reg whose identifier matches the identifier of the output port	Procedural assignment statements in initial statements can assign values to a variable whose identifier does not match the identifier of an output port
The procedural assignment statement shall assign one of the following values: 1'b1, 1'b0, 1'bx, 1, 0	Procedural assignment statements can assign values of any size, radix, and value

Example 1—The following example shows a sequential UDP that contains an initial statement.

```
primitive srff (q, s, r);
output q; reg q;
input s, r;
initial q = 1'b1;
table
// s  r  q  q+
  1  0  :  ?  :  1  ;
  f  0  :  1  :  -  ;
  0  r  :  ?  :  0  ;
  0  f  :  0  :  -  ;
  1  1  :  ?  :  0  ;
```

```

endtable
endprimitive

```

The output q has an initial value of 1 at the start of the simulation; a delay specification on an instantiated UDP does not delay the simulation time of the assignment of this initial value to the output. When simulation starts, this value is the current state in the state table. Delays are not permitted in a UDP initial statement.

Example 2—The following example and [Figure 29-1](#) show how values are applied in a module that instantiates a sequential UDP with an initial statement:

```

primitive dff1 (q, clk, d);
  input clk, d;
  output q; reg q;
  initial q = 1'b1;
  table
    // clk  d      q      q+
      r    0  :  ?  :  0  ;
      r    1  :  ?  :  1  ;
      f    ?  :  ?  :  -  ;
      ?    *  :  ?  :  -  ;
  endtable
endprimitive

module dff (q, qb, clk, d);
  input clk, d;
  output q, qb;
  dff1  g1 (qi, clk, d);
  buf #3 g2 (q, qi);
  not #5 g3 (qb, qi);
endmodule

```

The UDP `dff1` contains an initial statement that sets the initial value of its output to 1. The module `dff` contains an instance of UDP `dff1`.

[Figure 29-1](#) shows the schematic of the preceding module and the simulation propagation times of the initial value of the UDP output.

In [Figure 29-1](#), the fanout from the UDP output q_i includes nets q and q_b . At simulation time 0, q_i changes value to 1. That initial value of q_i does not propagate to net q until simulation time 3, and it does not propagate to net q_b until simulation time 5.

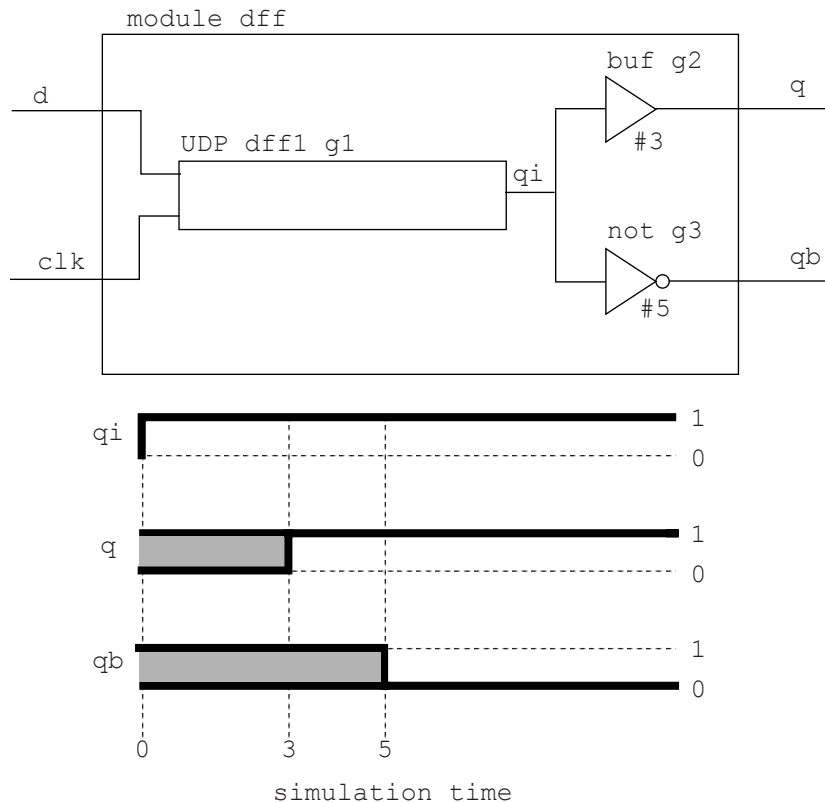

Figure 29-1—Module schematic and simulation times of initial value propagation

29.8 UDP instances

The syntax for creating a UDP instance is shown in [Syntax 29-2](#).

```

udp_instantiation ::= //from A.5.4
    udp_identifier [ drive_strength ] [ delay2 ] udp_instance { , udp_instance } ;
udp_instance ::= [ name_of_instance ] ( output_terminal , input_terminal { , input_terminal } )
name_of_instance ::= instance_identifier { unpacked_dimension } //from A.4.1.1

```

Syntax 29-2—Syntax for UDP instances (excerpt from [Annex A](#))

Instances of UDPs are specified inside modules in the same manner as gates (see [28.3](#)). The instance name is optional, just as for gates. The terminal connection order is as specified in the UDP definition. Only two delays may be specified because *z* is not supported for UDPs. An optional range may be specified for an array of UDP instances. The terminal connection rules remain the same as outlined in [28.3.6](#).

The following example creates an instance of the D-type flip-flop `d_edge_ff` (defined in [29.6](#)).

```

module flip;
    reg clock, data;
    parameter p1 = 10;
    parameter p2 = 33;

```

```

parameter p3 = 12;

d_edge_ff #p3 d_inst (q, clock, data);

initial begin
  data = 1;
  clock = 1;
  #(20 * p1) $finish;
end
always #p1 clock = ~clock;
always #p2 data = ~data;
endmodule

```

29.9 Mixing level-sensitive and edge-sensitive descriptions

UDP definitions allow a mixing of the level-sensitive and the edge-sensitive constructs in the same table. When the input changes, the edge-sensitive cases are processed first, followed by level-sensitive cases. Thus, when level-sensitive and edge-sensitive cases specify different output values, the result is specified by the level-sensitive case.

For example:

```

primitive jk_edge_ff (q, clock, j, k, preset, clear);
  output q; reg q;
  input clock, j, k, preset, clear;
  table
  // clock  jk  pc  state  output/next state
  ?  ??  01  : ? : 1 ; // preset logic
  ?  ??  *1  : 1 : 1 ;
  ?  ??  10  : ? : 0 ; // clear logic
  ?  ??  1*  : 0 : 0 ;
  r  00  00  : 0 : 1 ; // normal clocking cases
  r  00  11  : ? : - ;
  r  01  11  : ? : 0 ;
  r  10  11  : ? : 1 ;
  r  11  11  : 0 : 1 ;
  r  11  11  : 1 : 0 ;
  f  ??  ??  : ? : - ;
  b  *?  ??  : ? : - ; // j and k transition cases
  b  ?*  ??  : ? : - ;
  endtable
endprimitive

```

In this example, the `preset` and `clear` logic is level-sensitive. Whenever the preset and clear combination is 01, the output has value 1. Similarly, whenever the preset and clear combination has value 10, the output has value 0.

The remaining logic is sensitive to edges of the clock. In the normal clocking cases, the flip-flop is sensitive to the rising clock edge, as indicated by an `r` in the clock field in those entries. The insensitivity to the falling edge of clock is indicated by a hyphen (-) in the output field (see [Table 29-1](#)) for the entry with an `f` as the value of clock. Remember that the desired output for this input transition shall be specified to avoid unwanted `x` values at the output. The last two entries show that the transitions in `j` and `k` inputs do not change the output on a steady low or high clock.

29.10 Level-sensitive dominance

Table 29-3 shows level-sensitive and edge-sensitive entries in the example from 29.9, their level-sensitive or edge-sensitive behavior, and a case of input values that each includes.

Table 29-3—Mixing of level-sensitive and edge-sensitive entries

Entry	Included case	Behavior
? ?? 01: ?: 1;	0 00 01: 0: 1;	Level-sensitive
f ?? ??: ?: -;	f 00 01: 0: 0;	Edge-sensitive

The included cases specify opposite next state values for the same input and current state combination. The level-sensitive included case specifies that when the inputs `clock`, `jk`, and `pc` values are 0, 00, and 01 and the current state is 0, the output changes to 1. The edge-sensitive included case specifies that when `clock` falls from 1 to 0, the other inputs `jk` and `pc` are 00 and 01, and the current state is 0, then the output changes to 0.

When the edge-sensitive case is processed first, followed by the level-sensitive case, the output changes to 1.

30. Specify blocks

30.1 General

This clause describes the following:

- Module path declarations
- Module path delays
- Mixed path and distributed delays
- Pulse control filtering

30.2 Overview

Two types of constructs are often used to describe delays for structural models such as ASIC cells. They are as follows:

- *Distributed delays*, which specify the time it takes events to propagate through gates and nets inside the module (see [28.16](#))
- *Module path delays*, which describe the time it takes an event at a source (input port or inout port) to propagate to a destination (output port or inout port)

This clause describes how paths are specified in a module and how delays are assigned to these paths.

30.3 Specify block declaration

A block statement called the *specify block* is the vehicle for describing paths between a source and a destination and for assigning delays to these paths. The syntax for specify blocks is shown in [Syntax 30-1](#).

```
specify_block ::= specify { specify_item } endspecify //from A.7.1
specify_item ::=
    specparam_declaration
    | pulsestyle_declaration
    | showcanceled_declaration
    | path_declaration
    | system_timing_check
```

Syntax 30-1—Syntax for specify block (excerpt from [Annex A](#))

The specify block shall be bounded by the keywords **specify** and **endspecify**, and it shall appear inside a module declaration. The specify block can be used to perform the following tasks:

- Describe various paths across the module.
- Assign delays to those paths.
- Perform timing checks to verify that events occurring at the module inputs satisfy the timing constraints of the device described by the module (see [Clause 31](#)).

The paths described in the specify block, called *module paths*, pair a signal source with a signal destination. The source may be unidirectional (an input port) or bidirectional (an inout port) and is referred to as the *module path source*. Similarly, the destination may be unidirectional (an output port) or bidirectional (an inout port) and is referred to as the *module path destination*.

For example:

```
specify  
  specparam tRise_clk_q = 150, tFall_clk_q = 200;  
  specparam tSetup = 70;  
  
  (clk => q) = (tRise_clk_q, tFall_clk_q);  
  
  $setup(d, posedge clk, tSetup);  
endspecify
```

The first two lines following the keyword **specify** declare specify parameters, which are discussed in [6.20.5](#). The line following the declarations of specify parameters describes a module path and assigns delays to that module path. The specify parameters determine the delay assigned to the module path. Specifying module paths is presented in [30.4](#). Assigning delays to module paths is discussed in [30.5](#). The line preceding the keyword **endspecify** instantiates one of the system timing checks, which are discussed further in [Clause 31](#).

30.4 Module path declarations

There are two steps required to set up module path delays in a specify block:

- a) Describe the module paths.
- b) Assign delays to those paths (see [30.5](#)).

The syntax of the module path declaration is described in [Syntax 30-2](#).

```
path_declaration ::= // from A.7.2  
  simple_path_declaration ;  
  | edge_sensitive_path_declaration ;  
  | state_dependent_path_declaration ;
```

Syntax 30-2—Syntax for module path declaration (excerpt from [Annex A](#))

A module path may be described as a *simple path*, an *edge-sensitive path*, or a *state-dependent path*. A module path shall be defined inside a specify block as a connection between a source signal and a destination signal. Module paths can connect any combination of vectors and scalars.

Figure 30-1 illustrates an example circuit with module path delays. More than one source (A, B, C, and D) may have a module path to the same destination (Q), and different delays may be specified for each input to output path.

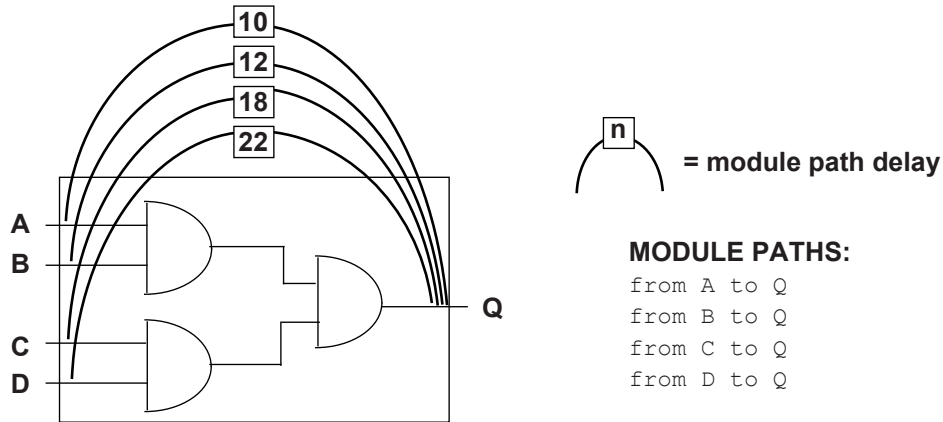

Figure 30-1—Module path delays

30.4.1 Module path restrictions

Module paths have the following restrictions:

- The module path source shall be a net that is connected to a module input port or inout port.
- The module path destination shall be a net or variable that is connected to a module output port or inout port.

30.4.2 Simple module paths

The syntax for specifying a simple module path is given in [Syntax 30-3](#).

```

simple_path_declaration ::= //from A.7.2
    parallel_path_description = path_delay_value
    | full_path_description = path_delay_value
parallel_path_description ::=
    ( specify_input_terminal_descriptor [ polarity_operator ] => specify_output_terminal_descriptor )
full_path_description ::=
    ( list_of_path_inputs [ polarity_operator ] *> list_of_path_outputs )
list_of_path_inputs ::=
    specify_input_terminal_descriptor { , specify_input_terminal_descriptor }
list_of_path_outputs ::=
    specify_output_terminal_descriptor { , specify_output_terminal_descriptor }
specify_input_terminal_descriptor ::= //from A.7.3
    input_identifier [ [ constant_range_expression ] ]
specify_output_terminal_descriptor ::=
    output_identifier [ [ constant_range_expression ] ]
input_identifier ::= input_port_identifier | inout_port_identifier | interface_identifier . port_identifier
output_identifier ::= output_port_identifier | inout_port_identifier | interface_identifier . port_identifier
polarity_operator ::= + | - //from A.7.4

```

Syntax 30-3—Syntax for simple module path (excerpt from [Annex A](#))

Simple paths can be declared in one of two forms:

- source *> destination
- source => destination

The symbols *> and => each represent a different kind of connection between the module path source and the module path destination. The operator *> establishes a *full connection* between source and destination. The operator => establishes a *parallel connection* between source and destination. See [30.4.5](#) for a description of full connection and parallel connection paths.

The following three examples illustrate valid simple module path declarations:

```
(A => Q) = 10;  
(B => Q) = (12);  
(C, D *> Q) = 18;
```

30.4.3 Edge-sensitive paths

When a module path is described using an edge transition at the source, it is called an *edge-sensitive path*. The edge-sensitive path construct is used to model the timing of input-to-output delays, which only occur when a specified edge occurs at the source signal.

The syntax of the edge-sensitive path declaration is shown in [Syntax 30-4](#).

```
edge_sensitive_path_declaration ::= // from A.7.4  
    parallel_edge_sensitive_path_description = path_delay_value  
    | full_edge_sensitive_path_description = path_delay_value  
parallel_edge_sensitive_path_description ::=  
    ( [ edge_identifier ] specify_input_terminal_descriptor [ polarity_operator ] =>  
      ( specify_output_terminal_descriptor [ polarity_operator ] : data_source_expression ) )  
full_edge_sensitive_path_description ::=  
    ( [ edge_identifier ] list_of_path_inputs [ polarity_operator ] *>  
      ( list_of_path_outputs [ polarity_operator ] : data_source_expression ) )  
data_source_expression ::= expression  
edge_identifier ::= posedge | negedge | edge  
polarity_operator ::= + | -
```

Syntax 30-4—Syntax for edge-sensitive path declaration (excerpt from [Annex A](#))

The edge identifier may be one of the keywords **posedge**, **negedge**, or **edge**, associated with an input terminal descriptor, which may be any input port or inout port. If a vector port is specified as the input terminal descriptor, the edge transition shall be detected on the least significant bit. If the edge transition is not specified, the path shall be considered active on any transition at the input terminal.

An edge-sensitive path may be specified with full connections (***>**) or parallel connections (**=>**). For parallel connections (**=>**), the destination shall be any scalar output or inout port or the bit-select of a vector output or inout port. For full connections (***>**), the destination shall be a list of one or more of the vector or scalar output and inout ports, and bit-selects or part-selects of vector output and inout ports. See [30.4.5](#) for a description of parallel paths and full connection paths.

The data source expression is an arbitrary expression, which serves as a description of the flow of data to the path destination. This arbitrary data path description does not affect the actual propagation of data or events

through the model; how an event at the data path source propagates to the destination depends on the internal logic of the module.

The polarity operator is optional. It describes whether the data path is inverting or noninverting. The polarity operator has no effect on simulation results. It can be used by timing analysis tools to propagate the timing of rising or falling edges in the absence of simulation data.

Example 1—The following example demonstrates an edge-sensitive path declaration with a positive polarity operator:

```
( posedge clock => ( out +: in ) ) = (10, 8);
```

In this example, at the positive edge of `clock`, a module path extends from `clock` to `out` using a rise delay of 10 and a fall delay of 8. The data path is from `in` to `out`, and `in` is not inverted as it propagates to `out`.

Example 2—The following example demonstrates an edge-sensitive path declaration with a negative polarity operator:

```
( negedge clock[0] => ( out -: in ) ) = (10, 8);
```

In this example, at the negative edge of `clock[0]`, a module path extends from `clock[0]` to `out` using a rise delay of 10 and a fall delay of 8. The data path is from `in` to `out`, and `in` is inverted as it propagates to `out`.

Example 3—The following example demonstrates an edge-sensitive path declaration with no edge identifier:

```
( clock => ( out : in ) ) = (10, 8);
```

In this example, at any change in `clock`, a module path extends from `clock` to `out`.

30.4.4 State-dependent paths

A *state-dependent path* makes it possible to assign a delay to a module path that affects signal propagation delay through the path only if specified conditions are true.

A state-dependent path description includes the following items:

- A conditional expression that, when evaluated true, enables the module path
- A module path description
- A delay expression that applies to the module path

The syntax for the state-dependent path declaration is shown in [Syntax 30-5](#).

```
state_dependent_path_declaration ::= // from A.7.4
  if ( module_path_expression ) simple_path_declaration
  | if ( module_path_expression ) edge_sensitive_path_declaration
  | ifnone simple_path_declaration
```

Syntax 30-5—Syntax for state-dependent paths (excerpt from [Annex A](#))

30.4.4.1 Conditional expression

The operands in the conditional expression shall be constructed from the following:

- Scalar or vector module input ports or inout ports or their bit-selects or part-selects
- Locally defined variables or nets or their bit-selects or part-selects
- Compile time constants (constant numbers and specify parameters)

[Table 30-1](#) contains a list of valid operators that may be used in conditional expressions.

Table 30-1—List of valid operators in state-dependent path delay expression

Operator	Description	Operator	Description
~	bitwise negation	&	reduction and
&	bitwise and		reduction or
	bitwise or	^	reduction xor
^	bitwise xor	~&	reduction nand
^~ ^	bitwise xnor	~	reduction nor
==	logical equality	^~ ^	reduction xnor
!=	logical inequality	{ }	concatenation
&&	logical and	{ { } }	replication
	logical or	?:	conditional
!	logical not		

A conditional expression shall evaluate to true (1) for the state-dependent path to be assigned a delay value. If the conditional expression evaluates to x or z, it shall be treated as true. If the conditional expression evaluates to multiple bits, the least significant bit shall represent the result. The conditional expression can have any number of operands and operators.

30.4.4.2 Simple state-dependent paths

If the path description of a state-dependent path is a simple path, then it is called a *simple state-dependent path*. The simple path description is discussed in [30.4.2](#).

Example 1—The following example uses state-dependent paths to describe the timing of an XOR gate.

```

module XORgate (a, b, out);
  input a, b;
  output out;

  xor x1 (out, a, b);

  specify
    specparam noninvrise = 1, noninvfall = 2;
    specparam invertrise = 3, invertfall = 4;
    if (a) (b => out) = (invertrise, invertfall);
    if (b) (a => out) = (invertrise, invertfall);
    if (~a) (b => out) = (noninvrise, noninvfall);
    if (~b) (a => out) = (noninvrise, noninvfall);
  endspecify
endmodule

```

In this example, the first two state-dependent paths describe a pair of output rise and fall delay times when the XOR gate (*x1*) inverts a changing input. The last two state-dependent paths describe another pair of output rise and fall delay times when the XOR gate buffers a changing input.

Example 2—The following example models a partial ALU. The state-dependent paths specify different delays for different ALU operations.

```

module ALU (o1, i1, i2, opcode);
  input [7:0] i1, i2;
  input [2:1] opcode;
  output [7:0] o1;

  //functional description omitted
  specify
    // add operation
    if (opcode == 2'b00) (i1,i2 *> o1) = (25.0, 25.0);
    // pass-through i1 operation
    if (opcode == 2'b01) (i1 => o1) = (5.6, 8.0);
    // pass-through i2 operation
    if (opcode == 2'b10) (i2 => o1) = (5.6, 8.0);
    // delays on opcode changes
    (opcode *> o1) = (6.1, 6.5);
  endspecify
endmodule

```

In the preceding example, the first three path declarations declare paths extending from operand inputs *i1* and *i2* to the *o1* output. The delays on these paths are assigned to operations on the basis of the operation specified by the inputs on *opcode*. The last path declaration declares a path from the *opcode* input to the *o1* output.

30.4.4.3 Edge-sensitive state-dependent paths

If the path description of a state-dependent path describes an edge-sensitive path, then the state-dependent path is called an *edge-sensitive state-dependent path*. The edge-sensitive paths are discussed in [30.4.3](#).

Different delays can be assigned to the same edge-sensitive path as long as the following criteria are met:

- The edge, condition, or both make each declaration unique.
- The port is referenced in the same way in all path declarations (entire port, bit-select, or part-select).

Example 1

```

if ( !reset && !clear )
  ( posedge clock => ( out +: in ) ) = (10, 8) ;

```

In this example, if the positive edge of *clock* occurs when *reset* and *clear* are low, a module path extends from *clock* to *out* using a rise delay of 10 and a fall delay of 8.

Example 2—The following example shows two edge-sensitive path declarations, each of which has a unique edge:

```

specify
  ( posedge clk => ( q[0] : data ) ) = (10, 5);
  ( negedge clk => ( q[0] : data ) ) = (20, 12);
endspecify

```

Example 3—The following example shows two edge-sensitive path declarations, each of which has a unique condition:

```

specify
  if (reset)
    (posedge clk => ( q[0] : data ) ) = (15, 8);
  if (!reset && cntrl)
    (posedge clk => ( q[0] : data ) ) = (6, 2);
endspecify

```

Example 4—The two state-dependent path declarations shown below are not legal because even though they have different conditions, the destinations are not specified in the same way: the first destination is a part-select, the second is a bit-select.

```

specify
  if (reset)
    (posedge clk => (q[3:0]:data)) = (10,5);
  if (!reset)
    (posedge clk => (q[0]:data)) = (15,8);
endspecify

```

30.4.4.4 The ifnone condition

The **ifnone** keyword is used to specify a default state-dependent path delay when all other conditions for the path are false. The **ifnone** condition shall specify the same module path source and destination as the state-dependent module paths. The following rules apply to module paths specified with the **ifnone** condition:

- Only simple module paths may be described with an **ifnone** condition.
- The state-dependent paths that correspond to the **ifnone** path may be either simple module paths or edge-sensitive paths.
- If there are no corresponding state-dependent module paths to the **ifnone** module path, then the **ifnone** module path shall be treated the same as an unconditional simple module path.
- It is illegal to specify both an **ifnone** condition for a module path and an unconditional simple module path for the same module path.

Example 1—The following are valid state-dependent path combinations:

```

if (C1) (IN => OUT) = (1,1);
ifnone (IN => OUT) = (2,2);

// add operation
if (opcode == 2'b00) (i1,i2 *> o1) = (25.0, 25.0);
// pass-through i1 operation
if (opcode == 2'b01) (i1 => o1) = (5.6, 8.0);
// pass-through i2 operation
if (opcode == 2'b10) (i2 => o1) = (5.6, 8.0);
// all other operations
ifnone (i2 => o1) = (15.0, 15.0);

if (C1) (posedge CLK => (Q +: D)) = (1,1);
ifnone (CLK => Q) = (2,2);

```

Example 2—The following module path description combination is illegal because it combines a state-dependent path using an **ifnone** condition and an unconditional path for the same module path:

```

if (a) (b => out) = (2,2);
if (b) (a => out) = (2,2);
ifnone (a => out) = (1,1);
(a => out) = (1,1);
    
```

30.4.5 Full connection and parallel connection paths

The operator `*>` shall be used to establish a *full connection* between source and destination. In a full connection, every bit in the source shall connect to every bit in the destination. The module path source need not have the same number of bits as the module path destination.

The full connection can handle most types of module paths because it does not restrict the size or number of source signals and destination signals. The following situations require the use of full connections:

- To describe a module path between a vector and a scalar
- To describe a module path between vectors of different sizes
- To describe a module path with multiple sources or multiple destinations in a single statement (see [30.4.6](#))

The operator `=>` shall be used to establish a *parallel connection* between source and destination. In a parallel connection, each bit in the source shall connect to one corresponding bit in the destination. Parallel module paths can be created only between sources and destinations that contain the same number of bits.

Parallel connections are more restrictive than full connections. They only connect one source to one destination, where each signal contains the same number of bits. Therefore, a parallel connection may only be used to describe a module path between two vectors of the same size. Because scalars are 1 bit wide, either `*>` or `=>` may be used to set up bit-to-bit connections between two scalars.

Example 1—[Figure 30-2](#) illustrates how a parallel connection differs from a full connection between two 4-bit vectors.

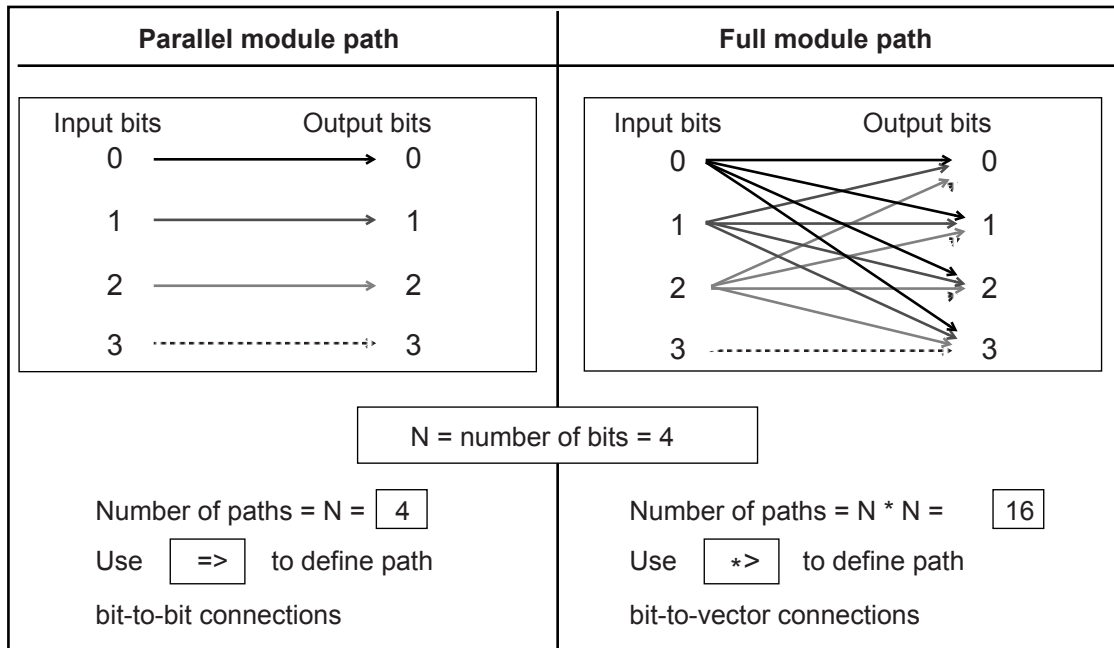

Figure 30-2—Difference between parallel and full connection paths

Example 2—The following example shows module paths for a 2:1 multiplexor with two 8-bit inputs and one 8-bit output:

```
module mux8 (in1, in2, s, q) ;
  output [7:0] q;
  input [7:0] in1, in2;
  input s;
  // Functional description omitted ...
  specify
    (in1 => q) = (3, 4) ;
    (in2 => q) = (2, 3) ;
    (s *> q) = 1;
  endspecify
endmodule
```

The module path from *s* to *q* uses a full connection (**>*) because it connects a scalar source—the 1-bit select line—to a vector destination—the 8-bit output bus. The module paths from both input lines *in1* and *in2* to *q* use a parallel connection (*=>*) because they set up parallel connections between two 8-bit buses.

30.4.6 Declaring multiple module paths in a single statement

Multiple module paths may be described in a single statement by using the symbol **>* to connect a comma-separated list of sources to a comma-separated list of destinations. When describing multiple module paths in one statement, the lists of sources and destinations may contain a mix of scalars and vectors of any size.

The connection in a multiple module path declaration is always a full connection.

For example:

```
(a, b, c *> q1, q2) = 10;
```

is equivalent to the following six individual module path assignments:

```
(a *> q1) = 10 ;
(b *> q1) = 10 ;
(c *> q1) = 10 ;
(a *> q2) = 10 ;
(b *> q2) = 10 ;
(c *> q2) = 10 ;
```

30.4.7 Module path polarity

The polarity of a module path is an arbitrary specification indicating whether the direction of a signal transition is inverted as it propagates from the input to the output. This arbitrary polarity description does not affect the actual propagation of data or events through the model; how a rise or a fall at the source propagates to the destination depends on the internal logic of the module.

Module paths may specify any of three polarities:

- Unknown polarity
- Positive polarity
- Negative polarity

30.4.7.1 Unknown polarity

By default, module paths shall have *unknown polarity*; that is, a transition at the path source may propagate to the destination in an unpredictable way, as follows:

- A rise at the source may cause a rise transition, a fall transition, or no transition at the destination.
- A fall at the source may cause a rise transition, a fall transition, or no transition at the destination.

A module path specified either as a full connection or as a parallel connection, but without a polarity operator + or -, shall be treated as a module path with unknown polarity.

For example:

```
// Unknown polarity
(In1 => q) = In_to_q ;
(s  *> q) = s_to_q ;
```

30.4.7.2 Positive polarity

For module paths with *positive polarity*, any transition at the source may cause the same transition at the destination, as follows:

- A rise at the source may cause either a rise transition or no transition at the destination.
- A fall at the source may cause either a fall transition or no transition at the destination.

A module path with positive polarity shall be specified by prefixing the + polarity operator to => or *>.

For example:

```
// Positive polarity
(In1 +=> q) = In_to_q ;
(s  +*> q) = s_to_q ;
```

30.4.7.3 Negative polarity

For module paths with *negative polarity*, any transition at the source may cause the opposite transition at the destination, as follows:

- A rise at the source may cause either a fall transition or no transition at the destination.
- A fall at the source may cause either a rise transition or no transition at the destination.

A module path with negative polarity shall be specified by prefixing the - polarity operator to => or *>.

For example:

```
// Negative polarity
(In1 -=> q) = In_to_q ;
(s  -*> q) = s_to_q ;
```

30.5 Assigning delays to module paths

The delays that occur at the module outputs where paths terminate shall be specified by assigning delay values to the module path descriptions. The syntax for specifying delay values is shown in [Syntax 30-6](#).

```

path_delay_value ::=
    list_of_path_delay_expressions
    | ( list_of_path_delay_expressions )
list_of_path_delay_expressions ::=
    t_path_delay_expression
    | trise_path_delay_expression , tfall_path_delay_expression
    | trise_path_delay_expression , tfall_path_delay_expression , tz_path_delay_expression
    | t01_path_delay_expression , t10_path_delay_expression , t0z_path_delay_expression ,
      tz1_path_delay_expression , t1z_path_delay_expression , tz0_path_delay_expression
    | t01_path_delay_expression , t10_path_delay_expression , t0z_path_delay_expression ,
      tz1_path_delay_expression , t1z_path_delay_expression , tz0_path_delay_expression ,
      t0x_path_delay_expression , tx1_path_delay_expression , t1x_path_delay_expression ,
      tx0_path_delay_expression , txz_path_delay_expression , tzx_path_delay_expression
t_path_delay_expression ::= path_delay_expression
path_delay_expression ::= constant_mintypmax_expression

```

Syntax 30-6—Syntax for path delay value (excerpt from [Annex A](#))

In module path delay assignments, a module path description (see [30.4](#)) is specified on the left-hand side, and one or more delay values are specified on the right-hand side. The delay values may be optionally enclosed in a pair of parentheses. There may be one, two, three, six, or twelve delay values assigned to a module path, as described in [30.5.1](#). The delay values shall be constant expressions containing literals or specparams, and there may be a delay expression of the form `min:typ:max`.

For example:

```

specify
    // Specify Parameters
    specparam tRise_clk_q = 45:150:270, tFall_clk_q=60:200:350;
    specparam tRise_Control = 35:40:45, tFall_control=40:50:65;

    // Module Path Assignments
    (clk => q) = (tRise_clk_q, tFall_clk_q);
    (clr, pre *> q) = (tRise_control, tFall_control);
endspecify

```

In the example above, the specify parameters declared following the **specparam** keyword specify values for the module path delays. The module path assignments assign those module path delays to the module paths.

30.5.1 Specifying transition delays on module paths

Each path delay expression may be a single value—representing the typical delay—or a colon-separated list of three values—representing a *minimum*, *typical*, and *maximum* delay, in that order. If the path delay expression results in a negative value, it shall be treated as zero. [Table 30-2](#) describes how different path delay values shall be associated with various transitions. The path delay expression names refer to the names used in [Syntax 30-6](#).

Table 30-2—Associating path delay expressions with transitions

Transitions	Number of path delay expressions specified				
	1	2	3	6	12
0 -> 1	t	trise	trise	t01	t01
1 -> 0	t	tfall	tfall	t10	t10
0 -> z	t	trise	tz	t0z	t0z
z -> 1	t	trise	trise	tz1	tz1
1 -> z	t	tfall	tz	t1z	t1z
z -> 0	t	tfall	tfall	tz0	tz0
0 -> x	a	a	a	a	t0x
x -> 1	a	a	a	a	tx1
1 -> x	a	a	a	a	t1x
x -> 0	a	a	a	a	tx0
x -> z	a	a	a	a	txz
z -> x	a	a	a	a	tzx

^a See [30.5.2](#).

For example:

```
// one expression specifies all transitions
(C => Q) = 20;
(C => Q) = 10:14:20;

// two expressions specify rise and fall delays
specparam tPLH1 = 12, tPHL1 = 25;
specparam tPLH2 = 12:16:22, tPHL2 = 16:22:25;
(C => Q) = ( tPLH1, tPHL1 );
(C => Q) = ( tPLH2, tPHL2 );

// three expressions specify rise, fall, and z transition delays
specparam tPLH1 = 12, tPHL1 = 22, tPz1 = 34;
specparam tPLH2 = 12:14:30, tPHL2 = 16:22:40, tPz2 = 22:30:34;
(C => Q) = (tPLH1, tPHL1, tPz1);
(C => Q) = (tPLH2, tPHL2, tPz2);

// six expressions specify transitions to/from 0, 1, and z
specparam t01 = 12, t10 = 16, t0z = 13,
           tz1 = 10, t1z = 14, tz0 = 34 ;
(C => Q) = ( t01, t10, t0z, tz1, t1z, tz0 ) ;
specparam T01 = 12:14:24, T10 = 16:18:20, T0z = 13:16:30 ;
specparam Tz1 = 10:12:16, T1z = 14:23:36, Tz0 = 15:19:34 ;
(C => Q) = ( T01, T10, T0z, Tz1, T1z, Tz0 ) ;

// twelve expressions specify all transition delays explicitly
specparam t01=10, t10=12, t0z=14, tz1=15, t1z=29, tz0=36,
```

$t_{0x}=14, t_{x1}=15, t_{1x}=15, t_{x0}=14, t_{xz}=20, t_{zx}=30 ;$
 $(C \Rightarrow Q) = (t_{01}, t_{10}, t_{0z}, t_{z1}, t_{1z}, t_{z0},$
 $t_{0x}, t_{x1}, t_{1x}, t_{x0}, t_{xz}, t_{zx}) ;$

30.5.2 Specifying x transition delays

If the x transition delays are not explicitly specified, the calculation of delay values for x transitions is based on the following two pessimistic rules:

- Transitions from a known state to x shall occur as quickly as possible; that is, the shortest possible delay shall be used for any transition to x.
- Transitions from x to a known state shall take as long as possible; that is, the longest possible delay shall be used for any transition from x.

Table 30-3 presents the general algorithm for calculating delay values for x transitions along with specific examples. The following two groups of x transitions are represented in the table:

- a) Transition from a known state s to x: $s \rightarrow x$
- b) Transition from x to a known state s: $x \rightarrow s$

Table 30-3—Calculating delays for x transitions

X transition	Delay value
General algorithm	
$s \rightarrow x$	minimum (s → other known signals)
$x \rightarrow s$	maximum (other known signals → s)
Specific transitions	
$0 \rightarrow x$	minimum (0 → z delay, 0 → 1 delay)
$1 \rightarrow x$	minimum (1 → z delay, 1 → 0 delay)
$z \rightarrow x$	minimum (z → 1 delay, z → 0 delay)
$x \rightarrow 0$	maximum (z → 0 delay, 1 → 0 delay)
$x \rightarrow 1$	maximum (z → 1 delay, 0 → 1 delay)
$x \rightarrow z$	maximum (1 → z delay, 0 → z delay)
Usage: (C ⇒ Q) = (5, 12, 17, 10, 6, 22) ;	
$0 \rightarrow x$	minimum (17, 5) = 5
$1 \rightarrow x$	minimum (6, 12) = 6
$z \rightarrow x$	minimum (10, 22) = 10
$x \rightarrow 0$	maximum (22, 12) = 22
$x \rightarrow 1$	maximum (10, 5) = 10
$x \rightarrow z$	maximum (6, 17) = 17

30.5.3 Delay selection

The simulator shall determine the proper delay to use when a specify path output is to be scheduled to transition. There may be specify paths to the output from more than one input, and the simulator must decide which specify path to use.

The simulator shall do this by first determining which specify paths to the output are active. Active specify paths are those whose input has transitioned most recently in time, and either they have no condition or their conditions are true. In the presence of simultaneous input transitions, it is possible for many specify paths to an output to be simultaneously active.

Once the active specify paths are identified, a delay shall be selected from among them. This is done by comparing the correct delay for the specific transition being scheduled from each specify path and choosing the smallest.

Example 1:

```
(A => Y) = (6, 9);
(B => Y) = (5, 11);
```

For a Y transition from 0 to 1, if A transitioned more recently than B, a delay of 6 will be chosen. But if B transitioned more recently than A, a delay of 5 will be chosen. And if, the last time they transitioned, A and B did so simultaneously, then the smallest of the two rise delays would be chosen, which is the rise delay from B of 5. The fall delay from A of 9 would be chosen if Y was instead to transition from 1 to 0.

Example 2:

```
if (MODE < 5) (A => Y) = (5, 9);
if (MODE < 4) (A => Y) = (4, 8);
if (MODE < 3) (A => Y) = (6, 5);
if (MODE < 2) (A => Y) = (3, 2);
if (MODE < 1) (A => Y) = (7, 7);
```

Anywhere from zero to five of these specify paths might be active depending upon the value of MODE. For instance, when MODE is 2, the first three specify paths are active. A rise transition would select a delay of 4 because that is the smallest rise delay among the first three. A fall transition would select a delay of 5 because that is the smallest fall delay among the first three.

30.6 Mixing module path delays and distributed delays

If a module contains module path delays and distributed delays (delays on primitive instances within the module), the larger of the two delays for each path shall be used.

Example 1—[Figure 30-3](#) illustrates a simple circuit modeled with a combination of distributed delays and path delays (only the D input to Q output path is illustrated). Here, the delay on the module path from input D to output Q is 22, while the sum of the distributed delays is $0 + 1 = 1$. Therefore, a transition on Q caused by a transition on D will occur 22 time units after the transition on D.

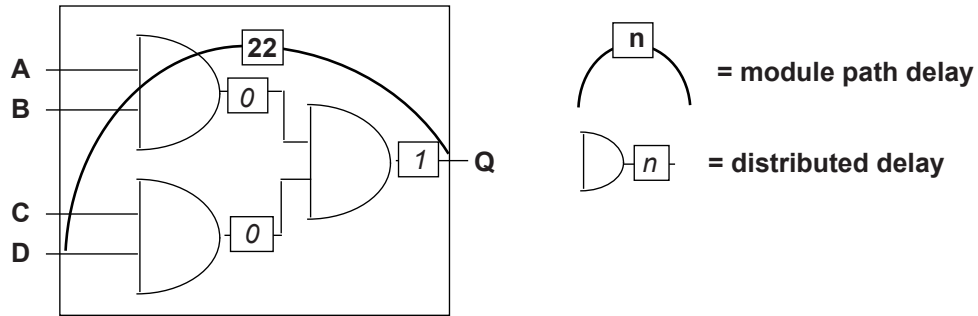

Figure 30-3—Module path delays longer than distributed delays

Example 2—In [Figure 30-4](#), the delay on the module path from D to Q is 22, but the distributed delays along that module path now add up to $10 + 20 = 30$. Therefore, an event on Q caused by an event on D will occur 30 time units after the event on D.

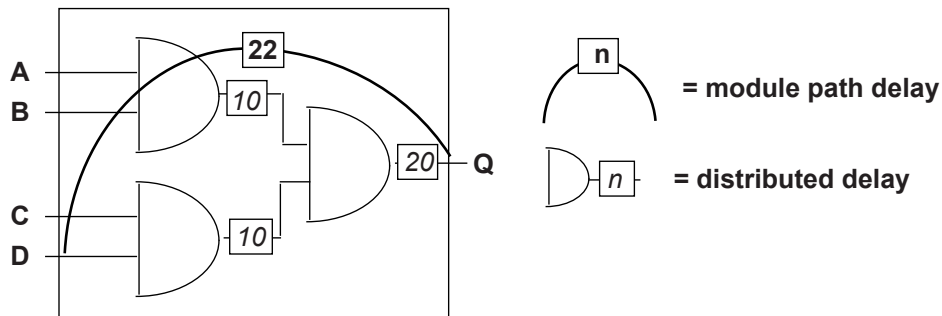

Figure 30-4—Module path delays shorter than distributed delays

30.7 Detailed control of pulse filtering behavior

Two consecutive scheduled transitions closer together in time than the module path delay are deemed a pulse. By default, pulses on a module path output are rejected. Consecutive transitions cannot be closer together than the module path delay, and this is known as the inertial delay model of pulse propagation.

Pulse width ranges control how to handle a pulse presented at a module path output. They are as follows:

- A pulse width range for which a pulse shall be rejected
- A pulse width range for which a pulse shall be allowed to propagate to the path destination
- A pulse width range for which a pulse shall generate a logic x on the path destination

Two pulse limit values define the pulse width ranges associated with each module path transition delay. The pulse limit values are called the *error limit* and the *reject limit*. The error limit shall always be at least as large as the reject limit. Pulses greater than or equal to the error limit pass unfiltered. Pulses less than the error limit but greater than or equal to the reject limit are filtered to x . Pulses less than the reject limit are rejected, and no pulse emerges. By default, both the error limit and the reject limit are set equal to the delay. These default values yield full inertial pulse behavior, rejecting all pulses smaller than the delay.

In [Figure 30-5](#), the rise delay from input A to output Y is 7, and the fall delay is 9. By default, the error limit and the reject limit for the rise delay are both 7. The error limit and the reject limit for the fall delay are both

9. The pulse limits associated with the delay forming the trailing edge of the pulse determine whether and how the pulse should be filtered. Waveform Y' shows the waveform resulting from no pulse filtering. The width of the pulse is 2, which is less than the reject limit for the rise delay of 7; therefore, the pulse is filtered as shown in waveform Y .

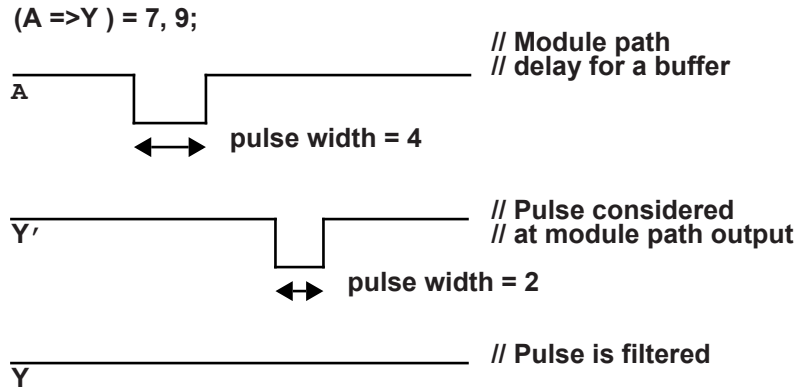

Figure 30-5—Example of pulse filtering

There are three ways to modify the pulse limits from their default values. First, SystemVerilog provides the `PATHPULSE$` specparam to modify the pulse limits from their default values. Second, invocation options can specify percentages applying to all module path delays to form the corresponding error limits and reject limits. Third, SDF annotation can individually annotate the error limit and reject limit of each module path transition delay.

30.7.1 Specify block control of pulse limit values

Pulse limit values may be set from within the specify block with the `PATHPULSE$` specparam. The syntax for using `PATHPULSE$` to specify the reject limit and error limit values is given in [Syntax 30-7](#).

```

pulse_control_specparam ::=
    PATHPULSE$ = ( reject_limit_value [ , error_limit_value ] )
    | PATHPULSE$specify_input_terminal_descriptor$specify_output_terminal_descriptor
      = ( reject_limit_value [ , error_limit_value ] )
error_limit_value ::= limit_value
reject_limit_value ::= limit_value
limit_value ::= constant_mintypmax_expression
    
```

Syntax 30-7—Syntax for `PATHPULSE$` pulse control (excerpt from [Annex A](#))

If only the reject limit value is specified, it shall apply to both the reject limit and the error limit.

The reject limit and error limit may be specified for a specific module path. When no module path is specified, the reject limit and error limit shall apply to all module paths defined in a module. If both path-specific `PATHPULSE$` specparams and a nonpath-specific `PATHPULSE$` specparam appear in the same module, then the path-specific specparams shall take precedence for the specified paths.

The module path input terminals and output terminals shall conform to the rules for module path inputs and outputs, with the following restriction: the terminals may not be a bit-select or part-select of a vector.

When a module path declaration declares multiple paths, the **PATHPULSE\$** specparam shall only be specified for the first path input terminal and the first path output terminal. The reject limit and error limit specified shall apply to all other paths in the multiple path declaration. A **PATHPULSE\$** specparam that specifies anything other than the first path input and path output terminals shall be ignored.

In the following example, the path (clk=>q) acquires a reject limit of 2 and an error limit of 9, as defined by the first **PATHPULSE\$** declaration. The paths (clr*>q) and (pre*>q) receive a reject limit of 0 and an error limit of 4, as specified by the second **PATHPULSE\$** declaration. The path (data=>q) is not explicitly defined in any of the **PATHPULSE\$** declarations; therefore, it acquires reject and error limit of 3, as defined by the last **PATHPULSE\$** declaration.

```
specify
  (clk => q) = 12;
  (data => q) = 10;
  (clr, pre *> q) = 4;

specparam
  PATHPULSE$clk$q = (2, 9),
  PATHPULSE$clr$q = (0, 4),
  PATHPULSE$ = 3;
endspecify
```

30.7.2 Global control of pulse limit values

Two invocation options can specify percentages applying globally to all module path transition delays. The error limit invocation option specifies the percentage of each module path transition delay used for its error limit value. The reject limit invocation option specifies the percentage of each module path transition delay used for its reject limit value. The percentage values shall be an integer between 0 and 100.

The default values for both the reject and error limit invocation options are 100%. When neither option is present, then 100% of each module transition delay is used as the reject and error limits.

It is an error if the error limit percentage is smaller than the reject limit percentage. In such cases, the error limit percentage is set equal to the reject limit percentage.

When both **PATHPULSE\$** and global pulse limit invocation options are present, the **PATHPULSE\$** values shall take precedence.

30.7.3 SDF annotation of pulse limit values

SDF annotation can be used to specify the pulse limit values of module path transition delays. [Clause 32](#) describes this in greater detail.

When **PATHPULSE\$**, global pulse limit invocation options, and SDF annotation of pulse limit values are present, SDF annotation values shall take precedence.

30.7.4 Detailed pulse control capabilities

The default style of pulse filtering behavior has two drawbacks. First, pulse filtering to the x state may be insufficiently pessimistic with an x state duration too short to be useful. Second, unequal delays can result in pulse rejection whenever the trailing edge precedes the leading edge, leaving no indication that a pulse was rejected. This subclause introduces more detailed pulse control capabilities.

30.7.4.1 On-event versus on-detect pulse filtering

When an output pulse is to be filtered to x , greater pessimism can be expressed if the module path output transitions immediately to x (*on-detect*) instead of at the already scheduled transition time of the leading edge of the pulse (*on-event*).

The on-event method of pulse filtering to x is the default. When an output pulse is to be filtered to x , the leading edge of the pulse becomes a transition to x , and the trailing edge becomes a transition from x . The times of transition of the edges do not change.

Just like on-event, the on-detect method of pulse filtering changes the leading edge of the pulse into a transition to x and the trailing edge to a transition from x , but the time of the leading edge is changed to occur immediately upon detection of the pulse.

[Figure 30-6](#) illustrates this behavior using a simple buffer with asymmetric rise/fall times and both the reject limits and error limits equal to 0. An output waveform is shown for both on-detect and on-event approaches.

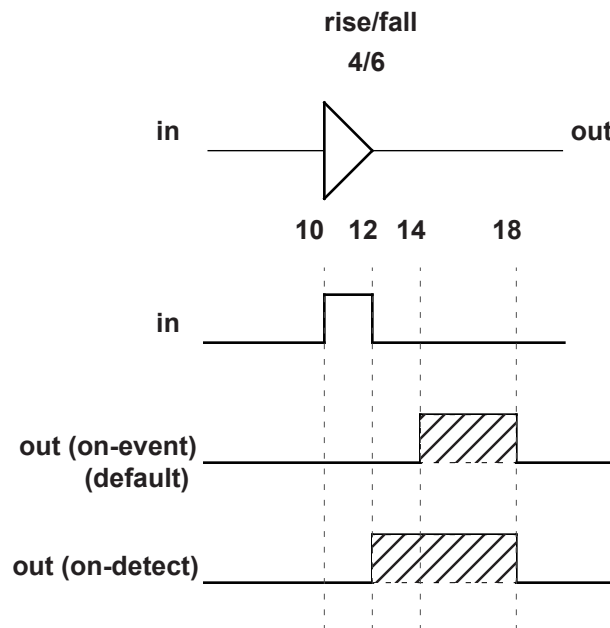

Figure 30-6—On-detect versus on-event

On-detect versus on-event behavior can be selected in two different ways. First, one may be selected globally for all module path outputs through use of the on-detect or on-event invocation option. Second, one may be selected locally through use of specify block pulse style declarations.

The syntax for *pulse* style declarations is shown in [Syntax 30-8](#).

```

pulsestyle_declaration ::= // from A.7.1
    pulsestyle_oneevent list_of_path_outputs ;
    | pulsestyle_ondetect list_of_path_outputs ;

```

Syntax 30-8—Syntax for pulse style declarations (excerpt from [Annex A](#))

It is an error if a module path output appears in a pulse style declaration after it has already appeared in a module path declaration.

The pulse style invocation options take precedence over pulse style specify block declarations.

30.7.4.2 Negative pulse detection

When the delays to a module path output are unequal, it is possible for the trailing edge of a pulse to be scheduled for a time earlier than the schedule time of the leading edge, yielding a pulse with a negative width. Under normal operation, if the schedule for a trailing pulse edge is earlier than the schedule for a leading pulse edge, then the leading edge is cancelled. No transition takes place when the initial and final states of the pulse are the same, leaving no indication a schedule was ever present.

Negative pulses can be indicated with the x state by use of the *showcancelled* style of behavior. When the trailing edge of a pulse would be scheduled before the leading edge, this style causes the leading edge to be scheduled to x and the trailing edge to be scheduled from x . With on-event pulse style, the schedule to x replaces the leading edge schedule. With on-detect pulse style, the schedule to x is made immediately upon detection of the negative pulse.

Showcancelled behavior can be enabled in two different ways. First, it may be enabled globally for all module path outputs through use of the **showcancelled** and **noshowcancelled** invocation options. Second, it may be enabled locally through use of specify block **showcancelled** declarations.

The syntax for *showcancelled* declarations is shown in [Syntax 30-9](#).

```
showcancelled_declaration ::= //from A.7.1  
    showcancelled list_of_path_outputs ;  
    | noshowcancelled list_of_path_outputs ;
```

Syntax 30-9—Syntax for showcancelled declarations (excerpt from [Annex A](#))

It is an error if a module path output appears in a showcancelled declaration after it has already appeared in a module path declaration. The showcancelled invocation options take precedence over the showcancelled specify block declarations.

The *showcancelled* behavior is illustrated in [Figure 30-7](#), which shows a narrow pulse presented at the input to a buffer with unequal rise/fall delays. This causes the trailing edge of the pulse to be scheduled earlier than leading edge. The leading edge of the input pulse schedules an output event 6 units later at the point marked by A. The pulse trailing edge occurs one time unit later, which schedules an output event 4 units later marked by point B. This second schedule on the output is for a time prior to the already existing schedule for the leading output pulse edge.

The output waveform is shown for three different operating modes. The first waveform shows the default behavior with showcancelled behavior not enabled and with the default on-event style. The second waveform shows showcancelled behavior in conjunction with on-event. The last waveform shows showcancelled behavior in conjunction with on-detect.

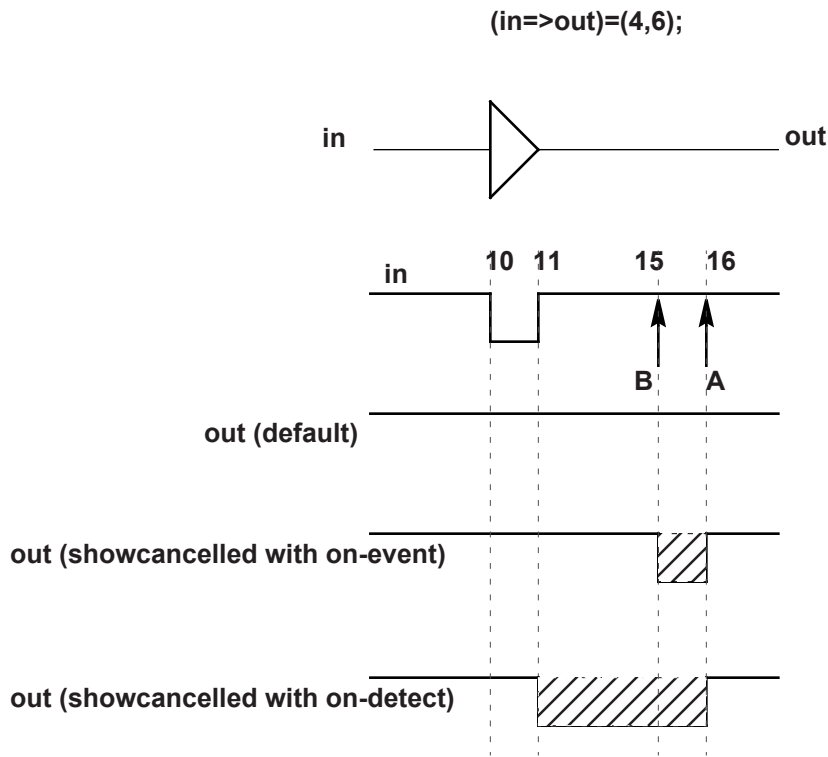

Figure 30-7—Current event cancellation problem and correction

This same situation can also arise with nearly simultaneous input transitions, which is defined as two inputs transitioning closer together in time than the difference in their respective delays to the output. [Figure 30-8](#) shows waveforms for a two-input NAND gate where initially A is high and B is low. B transitions 0→1 at time 10, causing a 1→0 output schedule at time 24. A transitions 1→0 at time 12, causing a 0→1 schedule at time 22. Arrows mark the output transitions caused by the transitions on inputs A and B.

The output waveform is shown for three different operating modes. The first waveform shows the default behavior with showcancelled behavior not enabled and with the default on-event style. The second shows showcancelled behavior in conjunction with on-event. The third shows showcancelled behavior in conjunction with on-detect.

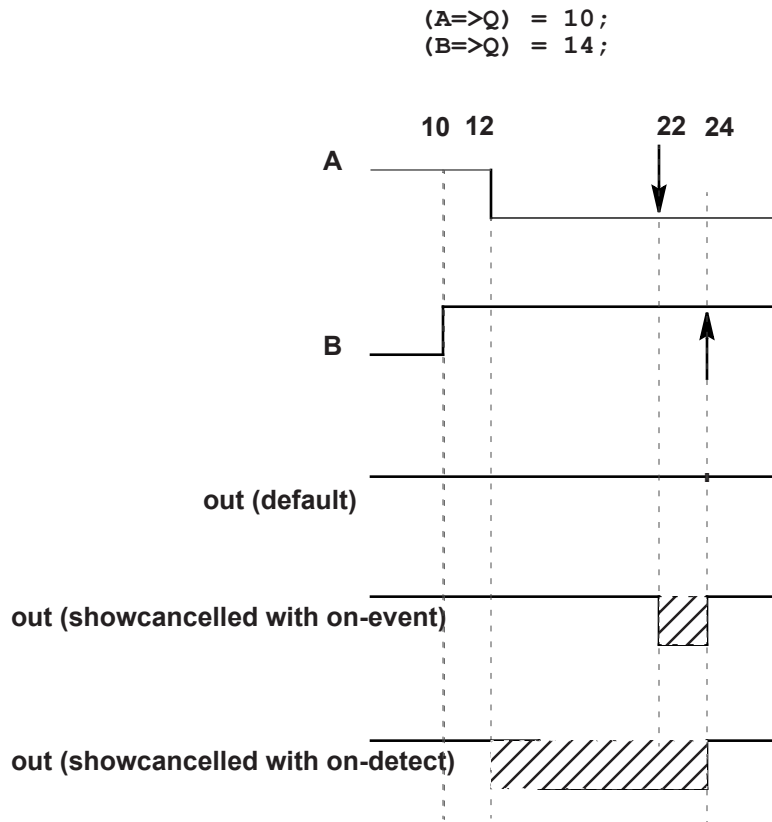

Figure 30-8—NAND gate with nearly simultaneous input switching where one event is scheduled prior to another that has not matured

One drawback of the on-event style with showcancelled behavior is that as the output pulse edges draw closer together, the duration of the resulting x state becomes smaller. [Figure 30-9](#) illustrates how the on-detect style solves this problem.

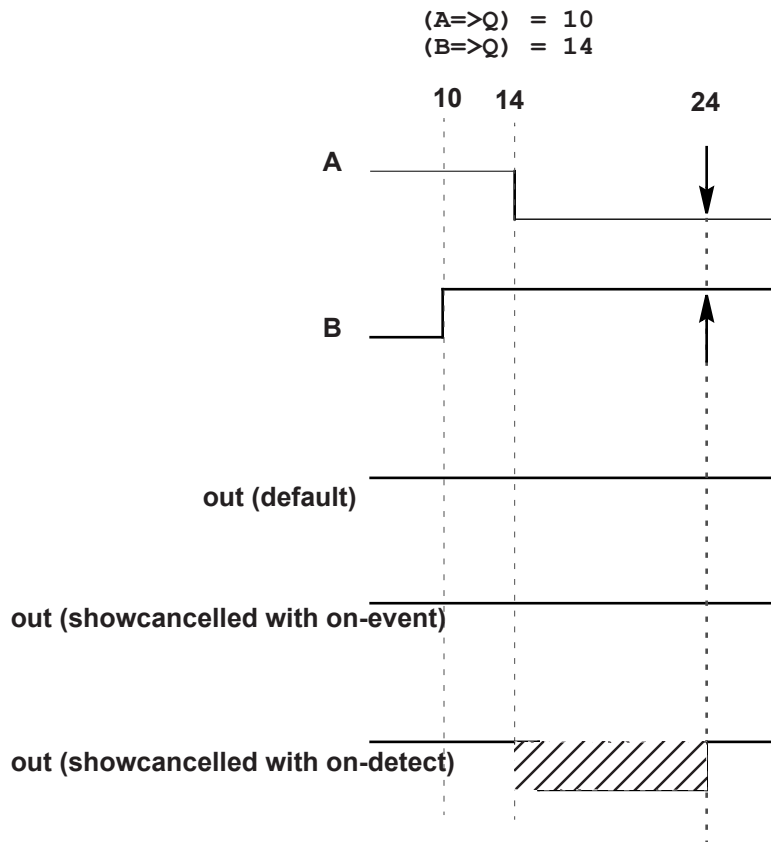

Figure 30-9—NAND gate with nearly simultaneous input switching with output event scheduled at same time

Example 1

```

specify
  (a=>out) = (2, 3);
  (b =>out) = (3, 4);
endspecify

```

Because no pulse style or showcancelled declarations appear within the specify block, the compiler applies the default modes of on-event and noshowcancelled.

Example 2

```

specify
  (a=>out) = (2, 3);
  showcancelled out;
  (b =>out) = (3, 4);
endspecify

```

This showcancelled declaration is in error because it follows use of out in a module path declaration. It would be contradictory for out to have noshowcancelled behavior from input a, but showcancelled behavior from input b.

Example 3—Both these specify blocks produce the same result. Outputs `out` and `out_b` are both declared `showcancelled` and `on-detect`.

```
specify  
  showcancelled out;  
  pulsestyle_ondetect out;  
  (a => out) = (2,3);  
  (b => out) = (4,5);  
  showcancelled out_b;  
  pulsestyle_ondetect out_b;  
  (a => out_b) = (3,4);  
  (b => out_b) = (5,6);  
endspecify  
  
specify  
  showcancelled out,out_b;  
  pulsestyle_ondetect out,out_b;  
  (a => out) = (2,3);  
  (b => out) = (4,5);  
  (a => out_b) = (3,4);  
  (b => out_b) = (5,6);  
endspecify
```

31. Timing checks

31.1 General

This clause describes the following:

- Stability timing checks
- Clock and control timing checks
- Edge control specifiers
- Notifiers
- Enabling timing checks
- Vectors in timing checks
- Negative timing checks

31.2 Overview

Timing checks can be placed in specify blocks to verify the timing performance of a design by making sure critical events occur within given time limits. The syntax for system timing checks is given in [Syntax 31-1](#).

```

system_timing_check ::= // from A.7.5.1
    $setup_timing_check
  | $hold_timing_check
  | $setuphold_timing_check
  | $recovery_timing_check
  | $removal_timing_check
  | $recrem_timing_check
  | $skew_timing_check
  | $timeskew_timing_check
  | $fullskew_timing_check
  | $period_timing_check
  | $width_timing_check
  | $nochange_timing_check

$setup_timing_check ::= // from A.7.5.1
    $setup ( data_event , reference_event , timing_check_limit [ , [ notifier ] ] ) ;

$hold_timing_check ::=
    $hold ( reference_event , data_event , timing_check_limit [ , [ notifier ] ] ) ;

$setuphold_timing_check ::=
    $setuphold ( reference_event , data_event , timing_check_limit , timing_check_limit
        [ , [ notifier ] [ , [ timestamp_condition ] [ , [ timecheck_condition ]
            [ , [ delayed_reference ] [ , [ delayed_data ] ] ] ] ] ) ;

$recovery_timing_check ::=
    $recovery ( reference_event , data_event , timing_check_limit [ , [ notifier ] ] ) ;

$removal_timing_check ::=
    $removal ( reference_event , data_event , timing_check_limit [ , [ notifier ] ] ) ;

$recrem_timing_check ::=
    $recrem ( reference_event , data_event , timing_check_limit , timing_check_limit
        [ , [ notifier ] [ , [ timestamp_condition ] [ , [ timecheck_condition ]
            [ , [ delayed_reference ] [ , [ delayed_data ] ] ] ] ] ) ;

$skew_timing_check ::=

```



```

    $skew ( reference_event , data_event , timing_check_limit [ , [ notifier ] ] ) ;
$timeskew_timing_check ::=
    $timeskew ( reference_event , data_event , timing_check_limit
        [ , [ notifier ] [ , [ event_based_flag ] [ , [ remain_active_flag ] ] ] ] ) ;
$fullskew_timing_check ::=
    $fullskew ( reference_event , data_event , timing_check_limit , timing_check_limit
        [ , [ notifier ] [ , [ event_based_flag ] [ , [ remain_active_flag ] ] ] ] ) ;
$period_timing_check ::=
    $period ( controlled_reference_event , timing_check_limit [ , [ notifier ] ] ) ;
$width_timing_check ::=
    $width ( controlled_reference_event , timing_check_limit , threshold [ , [ notifier ] ] ) ;
$nochange_timing_check ::=
    $nochange ( reference_event , data_event , start_edge_offset , end_edge_offset [ , [ notifier ] ] ) ;

```

Syntax 31-1—Syntax for system timing checks (excerpt from [Annex A](#))

The syntax for time check conditions and timing check events is given in [Syntax 31-2](#).

```

timecheck_condition ::= mintypmax_expression // from A.7.5.2
controlled_reference_event ::= controlled_timing_check_event
data_event ::= timing_check_event
delayed_data ::=
    terminal_identifier
    | terminal_identifier [ constant_mintypmax_expression ]
delayed_reference ::=
    terminal_identifier
    | terminal_identifier [ constant_mintypmax_expression ]
end_edge_offset ::= mintypmax_expression
event_based_flag ::= constant_expression
notifier ::= variable_identifier
reference_event ::= timing_check_event
remain_active_flag ::= constant_mintypmax_expression
timestamp_condition ::= mintypmax_expression
start_edge_offset ::= mintypmax_expression
threshold ::= constant_expression
timing_check_limit ::= expression
timing_check_event ::= // from A.7.5.3
    [timing_check_event_control] specify_terminal_descriptor [ &&& timing_check_condition ]
controlled_timing_check_event ::=
    timing_check_event_control specify_terminal_descriptor [ &&& timing_check_condition ]
timing_check_event_control ::=
    posedge
    | negedge
    | edge
    | edge_control_specifier

```

```

specify_terminal_descriptor ::=
    specify_input_terminal_descriptor
    | specify_output_terminal_descriptor
edge_control_specifier ::= edge [ edge_descriptor { , edge_descriptor } ]
edge_descriptor29 ::= 01 | 10 | z_or_x zero_or_one | zero_or_one z_or_x
zero_or_one ::= 0 | 1
z_or_x ::= x | X | z | Z
timing_check_condition ::=
    scalar_timing_check_condition
    | ( scalar_timing_check_condition )
scalar_timing_check_condition ::=
    expression
    | ~ expression
    | expression == scalar_constant
    | expression === scalar_constant
    | expression != scalar_constant
    | expression !== scalar_constant
scalar_constant ::= 1'b0 | 1'b1 | 1'B0 | 1'B1 | 'b0 | 'b1 | 'B0 | 'B1 | 1 | 0

```

²⁹⁾ Embedded spaces are illegal.

Syntax 31-2—Syntax for time check conditions and timing check events (excerpt from [Annex A](#))

For ease of presentation, the timing checks are divided into two groups. The first group of timing checks are described in terms of stability time windows:

\$setup	\$hold	\$setuphold
\$recovery	\$removal	\$recrem

The timing checks in the second group check clock and control signals and are described in terms of the difference in time between two events (the **\$nochange** check involves three events):

\$skew	\$timeskew	\$fullskew
\$width	\$period	\$nochange

Although they begin with a \$, timing checks are not system tasks. The leading \$ is present because of historical reasons, and timing checks shall not be confused with system tasks. In particular, no system task can appear in a specify block, and no timing check can appear in procedural code.

Some timing checks can accept negative limit values. This topic is discussed in detail in [31.9](#).

All timing checks have both a reference event and a data event, and Boolean conditions can be associated with each. Some of the checks have two signal arguments, one of which is the reference event and the other is the data event. Other checks have only one signal argument, and the reference and data events are derived from it. Reference events and data events shall only be detected by timing checks when their associated conditions are true. See [31.7](#) for more information about conditions in timing checks.

Timing check evaluation is based upon the times of two events, called the *timestamp event* and the *timecheck event*. A transition on the timestamp event signal causes the simulator to record (stamp) the time of transition for future use in evaluating the timing check. A transition on the timecheck event signal causes the simulator to actually evaluate the timing check to determine whether a violation has taken place.

For some checks, the reference event is always the timestamp event, and the data event is always the timecheck event; while for other checks the reverse is true. And for yet other checks, the decision about which is the timestamp and which is the timecheck event is based upon factors that are discussed in greater detail in [31.3](#) and [31.4](#).

Every timing check can include an optional notifier that toggles whenever the timing check detects a violation. The model can use the notifier to make behavior a function of timing check violations. Notifiers are discussed in greater detail in [31.6](#).

Like expressions for module path delays, timing check limit values are constant expressions that can include specparams.

31.3 Timing checks using a stability window

The following timing checks are discussed in this subclause:

\$setup	\$hold	\$setuphold
\$recovery	\$removal	\$recrem

These checks accept two signals, the reference event and the data event, and define a time window with respect to one signal while checking the time of transition of the other signal with respect to the window. In general, they all perform the following steps:

- a) Define a time window with respect to the reference signal using the specified limit or limits.
- b) Check the time of transition of the data signal with respect to the time window.
- c) Report a timing violation if the data signal transitions within the time window.

31.3.1 \$setup

The **\$setup** timing check syntax is shown in [Syntax 31-3](#).

```

$setup_timing_check ::=                                     // from A.7.5.1
    $setup ( data_event , reference_event , timing_check_limit [ , [ notifier ] ] ) ;
data_event ::= timing_check_event                         // from A.7.5.2
notifier ::= variable_identifier
reference_event ::= timing_check_event
timing_check_limit ::= expression
    
```

Syntax 31-3—Syntax for \$setup (excerpt from [Annex A](#))

[Table 31-1](#) defines the **\$setup** timing check.

Table 31-1—\$setup arguments

Argument	Description
data_event	Timestamp event
reference_event	Timecheck event
limit	Non-negative constant expression
notifier (optional)	Variable (see 31.6)

The data event is usually a data signal, while the reference event is usually a clock signal.

The end points of the time window are determined as follows:

```
(beginning of time window) = (timecheck time) - limit
(end of time window) = (timecheck time)
```

The **\$setup** timing check reports a timing violation in the following case:

```
(beginning of time window) < (timestamp time) < (end of time window)
```

The end points of the time window are not part of the violation region. When the limit is zero, the **\$setup** check shall never issue a violation.

31.3.2 \$hold

The **\$hold** timing check syntax is shown in [Syntax 31-4](#).

```
$hold_timing_check ::=
    $hold ( reference_event , data_event , timing_check_limit [ , [ notifier ] ] ) ; // from A.7.5.1
data_event ::= timing_check_event // from A.7.5.2
notifier ::= variable_identifier
reference_event ::= timing_check_event
timing_check_limit ::= expression
```

Syntax 31-4—Syntax for \$hold (excerpt from [Annex A](#))

[Table 31-2](#) defines the **\$hold** timing check.

Table 31-2—\$hold arguments

Argument	Description
reference_event	Timestamp event
data_event	Timecheck event
limit	Non-negative constant expression
notifier (optional)	Variable (see 31.6)

The data event is usually a data signal, while the reference event is usually a clock signal.

The end points of the time window are determined as follows:

```
(beginning of time window) = (timestamp time)
(end of time window) = (timestamp time) + limit
```

The **\$hold** timing check reports a timing violation in the following case:

```
(beginning of time window) <= (timecheck time) < (end of time window)
```

Only the end of the time window is not part of the violation region. When the limit is zero, the `$hold` check shall never issue a violation.

31.3.3 \$setuphold

The `$setuphold` timing check syntax is shown in [Syntax 31-5](#).

```

$setuphold_timing_check ::= // from A.7.5.1
    $setuphold ( reference_event , data_event , timing_check_limit , timing_check_limit
        [ , [ notifier ] [ , [ timestamp_condition ] [ , [ timecheck_condition ]
            [ , [ delayed_reference ] [ , [ delayed_data ] ] ] ] ] ) ;
timecheck_condition ::= mintypmax_expression // from A.7.5.2
data_event ::= timing_check_event
delayed_data ::=
    terminal_identifier
    | terminal_identifier [ constant_mintypmax_expression ]
delayed_reference ::=
    terminal_identifier
    | terminal_identifier [ constant_mintypmax_expression ]
notifier ::= variable_identifier
reference_event ::= timing_check_event
timestamp_condition ::= mintypmax_expression
timing_check_limit ::= expression
  
```

Syntax 31-5—Syntax for \$setuphold (excerpt from [Annex A](#))

[Table 31-3](#) defines the `$setuphold` timing check.

Table 31-3—\$setuphold arguments

Argument	Description
reference_event	Timecheck or timestamp event when setup limit is positive Timestamp event when setup limit is negative
data_event	Timecheck or timestamp event when hold limit is positive Timestamp event when hold limit is negative
setup_limit	Constant expression
hold_limit	Constant expression
notifier (optional)	Variable (see 31.6)
timestamp_condition (optional)	Timestamp condition for negative timing checks
timecheck_condition (optional)	Timecheck condition for negative timing checks
delayed_reference (optional)	Delayed reference signal for negative timing checks
delayed_data (optional)	Delayed data signal for negative timing checks

The `$setuphold` timing check can accept negative limit values. This is discussed in greater detail in [31.9](#).

The data event is usually a data signal, while the reference event is usually a clock signal.

When both the setup limit and the hold limit are positive, either the reference event or the data event can be the timecheck event. It shall depend upon which occurs first in the simulation.

When either the setup limit or the hold limit is negative, the restriction becomes as follows:

```
setup_limit + hold_limit > (simulation unit of precision)
```

The `$setuphold` timing check combines the functionality of the `$setup` and `$hold` timing checks into a single timing check. Therefore, the invocation

```
$setuphold( posedge clk, data, tSU, tHLD );
```

is equivalent in functionality to the following, if `tSU` and `tHLD` are not negative:

```
$setup( data, posedge clk, tSU );
$hold( posedge clk, data, tHLD );
```

When both setup and hold limits are positive and the data event occurs first, the end points of the time window are determined as follows:

```
(beginning of time window) = (timecheck time) - limit
(end of time window) = (timecheck time)
```

And the `$setuphold` timing check reports a timing violation in the following case:

```
(beginning of time window) < (timestamp time) <= (end of time window)
```

Only the beginning of the time window is not part of the violation region. The `$setuphold` check shall report a timing violation when the reference and data events occur simultaneously.

When both setup and hold limits are positive and the data event occurs second, the end points of the time window are determined as follows:

```
beginning of time window) = (timestamp time)
(end of time window) = (timestamp time) + limit
```

And the `$setuphold` timing check reports a timing violation in the following case:

```
(beginning of time window) <= (timecheck time) < (end of time window)
```

Only the end of the time window is not part of the violation region. The `$setuphold` check shall report a timing violation when the reference and data events occur simultaneously.

When both limits are zero, the `$setuphold` check shall never issue a violation.

31.3.4 \$removal

The `$removal` timing check syntax is shown in [Syntax 31-6](#).

```
$removal_timing_check ::= // from A.7.5.1
    $removal ( reference_event , data_event , timing_check_limit [ , [ notifier ] ] ) ;
data_event ::= timing_check_event // from A.7.5.2
```

notifier ::= variable_identifier
 reference_event ::= timing_check_event
 timing_check_limit ::= expression

Syntax 31-6—Syntax for \$removal (excerpt from Annex A)

[Table 31-4](#) defines the \$removal timing check.

Table 31-4—\$removal arguments

Argument	Description
reference_event	Timecheck event
data_event	Timestamp event
limit	Non-negative constant expression
notifier (optional)	Variable (see 31.6)

The reference event is usually a control signal like clear, reset, or set, while the data event is usually a clock signal.

The end points of the time window are determined as follows:

```
(beginning of time window) = (timecheck time) - limit
(end of time window) = (timecheck time)
```

The \$removal timing check reports a timing violation in the following case:

```
(beginning of time window) < (timestamp time) < (end of time window)
```

The end points of the time window are not part of the violation region. When the limit is zero, the \$removal check shall never issue a violation.

31.3.5 \$recovery

The \$recovery timing check syntax is shown in [Syntax 31-7](#).

```
$recovery_timing_check ::= $recovery ( reference_event , data_event , timing_check_limit [ , [ notifier ] ] ) ; // from A.7.5.1
data_event ::= timing_check_event // from A.7.5.2
notifier ::= variable_identifier
reference_event ::= timing_check_event
timing_check_limit ::= expression
```

Syntax 31-7—Syntax for \$recovery (excerpt from Annex A)

[Table 31-5](#) defines the `$recovery` timing check.

Table 31-5—\$recovery arguments

Argument	Description
reference_event	Timestamp event
data_event	Timecheck event
limit	Non-negative constant expression
notifier (optional)	Variable (see 31.6)

The reference event is usually a control signal like clear, reset, or set, while the data event is usually a clock signal.

The end points of the time window are determined as follows:

```
(beginning of time window) = (timestamp time)
(end of time window) = (timestamp time) + limit
```

The `$recovery` timing check reports a timing violation in the following case:

```
(beginning of time window) <= (timecheck time) < (end of time window)
```

Only the end of the time window is not part of the violation region. When the limit is zero, the `$recovery` check shall never issue a violation.

31.3.6 \$crem

The `$crem` timing check syntax is shown in [Syntax 31-8](#).

```
$crem_timing_check ::= // from A.7.5.1
    $crem ( reference_event , data_event , timing_check_limit , timing_check_limit
        [ , [ notifier ] [ , [ timestamp_condition ] [ , [ timecheck_condition ]
            [ , [ delayed_reference ] [ , [ delayed_data ] ] ] ] ] ) ;
timecheck_condition ::= mintypmax_expression // from A.7.5.2
data_event ::= timing_check_event
delayed_data ::=
    terminal_identifier
    | terminal_identifier [ constant_mintypmax_expression ]
delayed_reference ::=
    terminal_identifier
    | terminal_identifier [ constant_mintypmax_expression ]
notifier ::= variable_identifier
reference_event ::= timing_check_event
timestamp_condition ::= mintypmax_expression
timing_check_limit ::= expression
```

Syntax 31-8—Syntax for \$crem (excerpt from [Annex A](#))

[Table 31-6](#) defines the `$recrem` timing check.

Table 31-6—\$recrem arguments

Argument	Description
reference_event	Timecheck or timestamp event when removal limit is positive Timestamp event when removal limit is negative
data_event	Timecheck or timestamp event when recovery limit is positive Timestamp event when recovery limit is negative
recovery_limit	Constant expression
removal_limit	Constant expression
notifier (optional)	Variable (see 31.6)
timestamp_condition (optional)	Timestamp condition for negative timing checks
timecheck_condition (optional)	Timecheck condition for negative timing checks
delayed_reference (optional)	Delayed reference signal for negative timing checks
delayed_data (optional)	Delayed data signal for negative timing checks

The `$recrem` timing check can accept negative limit values. This is discussed in greater detail in [31.9](#).

When both the removal limit and the recovery limit are positive, either the reference event or the data event can be the timecheck event. It shall depend upon which occurs first in the simulation.

When either the removal limit or the recovery limit is negative, the restriction becomes as follows:

```
removal_limit + recovery_limit > (simulation unit of precision)
```

The `$recrem` timing check combines the functionality of the `$removal` and `$recovery` timing checks into a single timing check. Therefore, the invocation

```
$recrem( posedge clear, posedge clk, tREC, tREM );
```

is equivalent in functionality to the following, if `tREC` and `tREM` are not negative:

```
$removal( posedge clear, posedge clk, tREM );  
$recovery( posedge clear, posedge clk, tREC );
```

When both removal and recovery limits are positive and the data event occurs first, the end points of the time window are determined as follows:

```
(beginning of time window) = (timecheck time) - limit  
(end of time window) = (timecheck time)
```

And the `$recrem` timing check reports a timing violation in the following case:

```
(beginning of time window) < (timestamp time) <= (end of time window)
```

Only the beginning of the time window is not part of the violation region. The `$recrem` check shall report a timing violation when the reference and data events occur simultaneously.

When both removal and recovery limits are positive and the data event occurs second, the end points of the time window are determined as follows:

```
(beginning of time window) = (timestamp time)
(end of time window) = (timestamp time) + limit
```

And the `$recrem` timing check reports a timing violation in the following case:

```
(beginning of time window) <= (timecheck time) < (end of time window)
```

Only the end of the time window is not part of the violation region. The `$recrem` check shall report a timing violation when the reference and data events occur simultaneously.

When both limits are zero, the `$recrem` check shall never issue a violation.

31.4 Timing checks for clock and control signals

The following timing checks are discussed in this subclause:

```
$skew $timeskew $fullskew $period $width $nochange
```

These checks accept one or two signals and verify that transitions on them are never separated by more than the limit. For checks specifying only one signal, the reference event and data event are derived from that one signal. In general, these checks all perform the following steps:

- a) Determine the elapsed time between two events.
- b) Compare the elapsed time to the specified limit.
- c) Report a timing violation if the elapsed time violates the limit.

The skew checks have two different violation detection mechanisms, *event-based* and *timer-based*. Event-based skew checking is performed only when a signal transitions, while timer-based skew checking takes place as soon as the simulation time equal to the skew limit has elapsed.

The `$nochange` check involves three events rather than two.

31.4.1 \$skew

The `$skew` timing check syntax is shown in [Syntax 31-9](#).

```
$skew_timing_check ::= // from A.7.5.1
    $skew ( reference_event , data_event , timing_check_limit [ , [ notifier ] ] ) ;
data_event ::= timing_check_event // from A.7.5.2
notifier ::= variable_identifier
reference_event ::= timing_check_event
timing_check_limit ::= expression
```

Syntax 31-9—Syntax for \$skew (excerpt from [Annex A](#))

[Table 31-7](#) defines the `$skew` timing check.

Table 31-7—\$skew arguments

Argument	Description
reference_event	Timestamp event
data_event	Timecheck event
limit	Non-negative constant expression
notifier (optional)	Variable (see 31.6)

The `$skew` timing check reports a violation in the following case:

$$(\text{timecheck time}) - (\text{timestamp time}) > \text{limit}$$

Simultaneous transitions on the reference and data signals shall not cause `$skew` to report a timing violation, even when the skew limit value is zero.

The `$skew` timing check is event-based; it is evaluated only after a data event. If there is never a data event (i.e., the data event is infinitely late), the `$skew` timing check shall never be evaluated, and no timing violation shall ever be reported. In contrast, the `$timeskew` and `$fullskew` checks are timer-based by default, and they should be used if violation reports are absolutely required and the data event can be very late or even absent altogether. These checks are discussed in [31.4.2](#) and [31.4.3](#).

`$skew` shall wait indefinitely for the data event once it has detected a reference event, and it shall not report a timing violation until the data event takes place. A second consecutive reference event shall cancel the old wait for the data event and begin a new one.

After a reference event, the `$skew` timing check shall never stop checking data events for a timing violation. `$skew` shall report timing violations for all data events occurring beyond the limit after a reference event.

31.4.2 \$timeskew

The syntax for `$timeskew` is shown in [Syntax 31-10](#).

```

$timeskew_timing_check ::=                                     // from A.7.5.1
    $timeskew ( reference_event , data_event , timing_check_limit
        [ , [ notifier ] [ , [ event_based_flag ] [ , [ remain_active_flag ] ] ] ] ) ;
data_event ::= timing_check_event                             // from A.7.5.2
event_based_flag ::= constant_expression
notifier ::= variable_identifier
reference_event ::= timing_check_event
remain_active_flag ::= constant_mintypmax_expression
timing_check_limit ::= expression

```

Syntax 31-10—Syntax for \$timeskew (excerpt from [Annex A](#))

Table 31-8 defines the `$timeskew` timing check arguments.

Table 31-8—\$timeskew arguments

Argument	Description
reference_event	Timestamp event
data_event	Timecheck event
limit	Non-negative constant expression
notifier (optional)	Variable (see 31.6)
event_based_flag (optional)	Constant expression
remain_active_flag (optional)	Constant expression

The `$timeskew` timing check reports a violation only in the following case:

$$(\text{timecheck time}) - (\text{timestamp time}) > \text{limit}$$

Simultaneous transitions on the reference and data signals shall not cause `$timeskew` to report a timing violation, even when the skew limit value is zero. `$timeskew` shall also not report a violation if a new timestamp event occurs exactly at the expiration of the time limit.

The default behavior for `$timeskew` is timer-based. A violation shall be reported immediately upon an elapse of time after the reference event equal to the limit, and the check shall become dormant and report no more violations (even in response to data events) until after the next reference event. However, if a data event occurs within the limit, then a violation shall not be reported, and the check shall become dormant immediately. This check shall also become dormant if it detects a conditioned reference event when its condition is false and the `remain_active_flag` is not set.

The `$timeskew` check’s default timer-based behavior can be altered to event-based using the `event_based_flag`. It behaves like the `$skew` check when both the `event_based_flag` and the `remain_active_flag` are set. The `$timeskew` check behaves like the `$skew` check when only the `event_based_flag` is set, except that it becomes dormant after reporting the first violation or if it detects a conditioned reference event when its condition is false.

For example, see Figure 31-1.

```
$timeskew (posedge CP &&& MODE, negedge CPN, 50, , event_based_flag,
remain_active_flag);
```

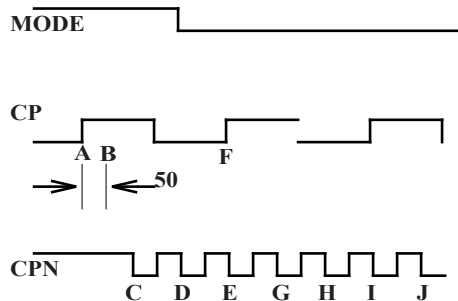

Figure 31-1—Sample \$timeskew

Case 1: event_based_flag not set, remain_active_flag not set.

After the first reference event on CP at A, a violation is reported at B as soon as 50 time units have passed, turning the \$timeskew check dormant, and no further violations are reported.

Case 2: event_based_flag set, remain_active_flag not set.

After the first reference event on CP at A, the negative transition on CPN at point C causes a timing violation, turning the \$timeskew check dormant, and no further violations are reported. The second reference event at F occurs while MODE is false; therefore, the \$timeskew check remains dormant.

Case 3: event_based_flag set, remain_active_flag set.

After the first reference event on CP at A, the first three negative transitions on CPN at points C, D, and E cause timing violations. The second reference event at F occurs while MODE is false, but because the remain_active_flag is set, the \$timeskew check remains active. Therefore, additional violations are reported at G, H, I, and J. In other words, all negative transitions on CPN cause violations, which is identical to \$skew behavior.

Case 4: event_based_flag not set, remain_active_flag set.

For the waveform depicted in [Figure 31-1](#), \$timeskew has the same behavior in Case 4 as in Case 1. The difference between the two cases is illustrated by the waveform in [Figure 31-2](#).

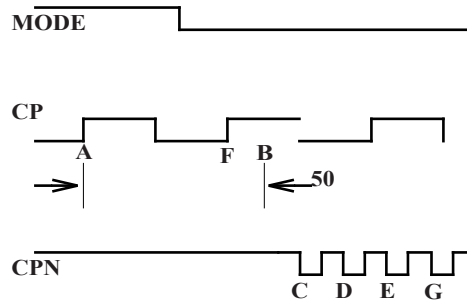

Figure 31-2—Sample \$timeskew with remain_active_flag set

Although the reference event on CP at F occurs while MODE is false, it does not turn the \$timeskew check dormant because the remain_active_flag is set. A violation will hence be reported at time B, whereas for Case 1, where the remain_active_flag is not set, the \$timeskew check would turn dormant at F, and no violation would be reported.

31.4.3 \$fullskew

The syntax for \$fullskew is shown in [Syntax 31-11](#).

```

$fullskew_timing_check ::= // from A.7.5.1
    $fullskew ( reference_event , data_event , timing_check_limit , timing_check_limit
        [ , [ notifier ] [ , [ event_based_flag ] [ , [ remain_active_flag ] ] ] ] ) ;
data_event ::= timing_check_event // from A.7.5.2
event_based_flag ::= constant_expression
notifier ::= variable_identifier
  
```

reference_event ::= timing_check_event
remain_active_flag ::= constant_mintypmax_expression
timing_check_limit ::= expression

Syntax 31-11—Syntax for \$fullskew (excerpt from Annex A)

Table 31-9 defines the \$fullskew timing check arguments.

Table 31-9—\$fullskew arguments

Argument	Description
reference_event	Timestamp or timecheck event
data_event	Timestamp or timecheck event
limit 1	Non-negative constant expression
limit 2	Non-negative constant expression
notifier (optional)	Variable (see 31.6)
event_based_flag (optional)	Constant expression
remain_active_flag (optional)	Constant expression

\$fullskew is similar to \$timeskew except that the reference and data events can transition in either order. The first limit is the maximum time by which the data event should follow the reference event. The second limit is the maximum time by which the reference event should follow the data event.

The reference event is the timestamp event, and the data event is the timecheck event when the reference event precedes the data event. The data event is the timestamp event, and the reference event is the timecheck event when the data event precedes the reference event.

The \$fullskew timing check reports a violation only in the following case, where limit is set to limit1 when the reference event transitions first and set to limit2 when the data event transitions first:

$$(\text{timecheck time}) - (\text{timestamp time}) > \text{limit}$$

Simultaneous transitions on the reference and data signals shall not cause \$fullskew to report a timing violation, even when the skew limit value is zero. \$fullskew shall also not report a violation if a new timestamp event occurs exactly at the expiration of the time limit.

The default behavior for \$fullskew is timer-based (event_based_flag not set). A violation shall be reported immediately upon elapse of the time limit after the timestamp event if a timecheck event does not occur in this time, turning the timing check dormant. However, if a timecheck event does occur within the time limit, then no violation is reported, and the timing check turns dormant immediately.

A reference event or data event is a timestamp event and starts a new timing window, unless it is a timecheck event occurring within the time limit after a preceding timestamp event, in which case it turns the timing check dormant, as stated above.

In the timer-based mode, a second timestamp event that occurs within the time limit starts a new timing window that replaces the first one, unless the second timestamp event has an associated condition whose value is false. In such a case, the behavior of \$fullskew depends on the remain_active_flag. If the flag is

set, then the second timestamp event is simply ignored. If the flag is not set and if the timing check is active, then the timing check turns dormant.

The `$fullskew` check's default timer-based behavior can be altered to event-based using the `event_based_flag`. In this mode, `$fullskew` is similar to `$skew` in that a violation is reported not upon elapse of the time limit after the timestamp event (as in timer-based mode), but rather if a timecheck event occurs after the time limit. Such an event ends the first timing window and immediately begins a new timing window, where it acts as the timestamp event of the new window. A timecheck event within the time limit ends the timing window and turns the timing check dormant, and no violation is reported.

In the event-based mode, a second timestamp event that occurs before a timecheck event has occurred starts a new timing window that replaces the first one, unless the second timestamp event has an associated condition whose value is false. In such a case, the behavior of `$fullskew` depends on the `remain_active_flag`. If the flag is set, then the second timestamp event is simply ignored. If the flag is not set and if the timing check is active, then the timing check turns dormant.

In both the timer-based and event-based modes, if the timestamp event has no condition or has a true condition and if the timing check is dormant, then the timing check is activated.

For example, see [Figure 31-3](#).

```
$fullskew (posedge CP &&& MODE, negedge CPN, 50, 70,, event_based_flag,
remain_active_flag);
```

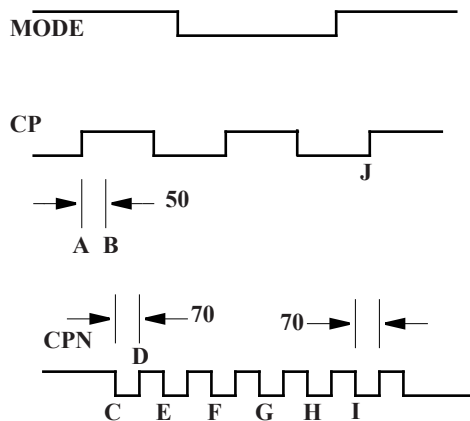

Figure 31-3—Sample `$fullskew`

Case 1: `event_based_flag` not set.

The transition at A of `CP` while `MODE` is true begins a wait for a negative transition on `CPN`, and a violation is reported at B as soon as a period of time equal to 50 time units has passed. This resets the check and readies it for the next active transition.

A negative transition on `CPN` occurs next at C, beginning a wait for a positive transition on `CP` while `MODE` is true. At D, a time equal to 70 time units has passed without a positive edge on `CP` while `MODE` is true; therefore, a violation is reported, and the check is again reset to await the next active transition.

A transition on `CPN` at E also results in a timing violation, as does the transition at F, because even though `CP` transitions, `MODE` is no longer true. Transitions at G and H also result in timing violations, but not the transition at I because it is followed by a positive transition on `CP` while `MODE` is true.

Case 2: event_based_flag set.

The transition at A of CP while MODE is true begins a wait for a negative transition on CPN, and a violation is reported at C on CPN because it occurs beyond the 50 time unit limit. This transition at C also begins a wait of 70 time units for a positive transition on CP while MODE is true. But for transitions on CPN at C through H, there is no positive transition on CP while MODE is true; therefore, no timing violations are reported. The transition at I on CPN begins a wait of 70 time units, and this is satisfied by the positive transition on CP at J while MODE is true.

Although the waveform in this particular example does not show the role of the remain_active_flag, it should be recognized that this flag has a vital role in determining the behavior of the \$fullskew timing check, just as it does for the \$timeskew timing check.

31.4.4 \$width

The \$width timing check syntax is shown in [Syntax 31-12](#).

```

$width_timing_check ::= // from A.7.5.1
    $width ( controlled_reference_event , timing_check_limit , threshold [ , [ notifier ] ] ) ;
controlled_reference_event ::= controlled_timing_check_event // from A.7.5.2
notifier ::= variable_identifier
threshold ::= constant_expression
timing_check_limit ::= expression

```

Syntax 31-12—Syntax for \$width (excerpt from [Annex A](#))

[Table 31-10](#) defines the \$width timing check.

Table 31-10—\$width arguments

Argument	Description
reference_event	Timestamp edge triggered event
data_event (implicit)	Timecheck edge triggered event
limit	Non-negative constant expression
threshold (optional)	Non-negative constant expression
notifier (optional)	Variable (see 31.6)

The \$width timing check monitors the width of signal pulses by measuring the time from the timestamp event to the timecheck event. Because a data event is not passed to \$width, it is derived from the reference event, as follows:

data event = reference event signal with opposite edge

Because of the way the data event is derived for \$width, an edge triggered event has to be passed as the reference event. A compilation error shall occur if the reference event is not an edge specification.

While the `$width` timing check can be defined in terms of a time window, it is simpler to express it as the difference between the timecheck and timestamp times. The `$width` timing check reports a violation in the following case:

```
threshold < (timecheck time) - (timestamp time) < limit
```

The pulse width has to be greater than or equal to limit in order to avoid a timing violation, but no violation is reported for glitches smaller than the threshold.

The threshold argument shall be included if the notifier argument is required. It is permissible to not specify both the threshold and notifier arguments, making the default value for the threshold zero. If the notifier is present, a non-null value for the threshold shall also be present. Here is a legal `$width` check when the notifier is required and the threshold is not:

```
$width (posedge clk, 6, 0, ntfr_reg);
```

The data event and the reference event shall never occur at the same simulation time because these events are triggered by opposite transitions.

The following example demonstrates some examples of legal and illegal calls:

```
// Legal Calls
$width ( negedge clr, lim );
$width ( negedge clr, lim, thresh, notif );
$width ( negedge clr, lim, 0, notif );

// Illegal Calls
$width ( negedge clr, lim, , notif );
$width ( negedge clr, lim, notif );
```

31.4.5 \$period

The `$period` timing check syntax is shown in [Syntax 31-13](#).

```
$period_timing_check ::= // from A.7.5.1
    $period ( controlled_reference_event , timing_check_limit [ , [ notifier ] ] ) ;
controlled_reference_event ::= controlled_timing_check_event // from A.7.5.2
notifier ::= variable_identifier
timing_check_limit ::= expression
```

Syntax 31-13—Syntax for \$period (excerpt from Annex A)

[Table 31-11](#) defines the `$period` timing check.

Table 31-11—\$period arguments

Argument	Description
reference_event	Timestamp edge triggered event
data_event (implicit)	Timecheck edge triggered event
limit	Non-negative constant expression
notifier (optional)	Variable (see 31.6)

Because the data event is not passed as an argument to `$period`, it is derived from the reference event, as follows:

```
data event = reference event signal with the same edge
```

Because of the way the data event is derived for `$period`, an edge triggered event shall be passed as the reference event. A compilation error shall occur if the reference event is not an edge specification.

While the `$period` timing check can be defined in terms of a time window, it is simpler to express it as the difference between the timecheck and timestamp times. The `$period` timing check reports a violation in the following case:

```
(timecheck time) - (timestamp time) < limit
```

31.4.6 \$nochange

The `$nochange` syntax is shown in [Syntax 31-14](#).

```
$nochange_timing_check ::= // from A.7.5.1  
    $nochange ( reference_event , data_event , start_edge_offset , end_edge_offset [ , [ notifier ] ] );  
data_event ::= timing_check_event // from A.7.5.2  
end_edge_offset ::= mintypmax_expression  
notifier ::= variable_identifier  
reference_event ::= timing_check_event  
start_edge_offset ::= mintypmax_expression
```

Syntax 31-14—Syntax for \$nochange (excerpt from [Annex A](#))

[Table 31-12](#) defines the `$nochange` timing check arguments.

Table 31-12—\$nochange arguments

Argument	Description
reference_event	Edge triggered timestamp and/or timecheck event
data_event	Timestamp or timecheck event
start_edge_offset	Constant expression
end_edge_offset	Constant expression
notifier (optional)	Variable (see 31.6)

The `$nochange` timing check reports a timing violation if the data event occurs during the specified level of the control signal (the *reference event*). The reference event can be specified with the `posedge` or the `negedge` keyword, but the edge-control specifiers (see [31.5](#)) cannot be used.

The start edge and end edge offsets can expand or shrink the timing violation region, which is defined by the duration of the reference event signal after the edge. For example, if the reference event is a `posedge`, then the duration is the period during which the reference signal is high. A positive offset for start edge extends the region by starting the timing violation region earlier; a negative offset for start edge shrinks the region by starting the region later. Similarly, a positive offset for the end edge extends the timing violation region by

ending it later, while a negative offset for the end edge shrinks the region by ending it earlier. If both the offsets are zero, the size of the region shall not change.

Unlike other timing checks, **\$nochange** involves three, rather than two, transitions. The leading edge of the reference event defines the beginning of the time window, while the trailing edge of the reference event defines the end of the time window. A violation results if the data event occurs anytime within the time window.

The end points of the time window are determined as follows:

```
(beginning of time window) = (leading reference edge time) - start_edge_offset
(end of time window) = (trailing reference edge time) + end_edge_offset
```

The **\$nochange** timing check reports a timing violation in the following case:

```
(beginning of time window) < (data event time) < (end of time window)
```

The end points of the time window are not included. The values of `start_edge_offset` and `end_edge_offset` play a significant role in determining which signal, the reference event or the data event, is the timestamp or timecheck event.

For example:

```
$nochange ( posedge clk, data, 0, 0) ;
```

In this example, the **\$nochange** timing check shall report a violation if the `data` signal changes while `clk` is high. It shall not be a violation if `posedge clk` and a transition on `data` occur simultaneously.

31.5 Edge-control specifiers

The edge-control specifiers can be used to control events in timing checks based on specific edge transitions between 0, 1, and x. [Syntax 31-15](#) shows the syntax for edge-control specifiers.

```
edge_control_specifier ::= edge [ edge_descriptor { , edge_descriptor } ]           // from A.7.5.3
edge_descriptor29 ::= 01 | 10 | z_or_x zero_or_one | zero_or_one z_or_x
zero_or_one ::= 0 | 1
z_or_x ::= x | x | z | z
```

²⁹) Embedded spaces are illegal.

Syntax 31-15—Syntax for edge-control specifier (excerpt from [Annex A](#))

Edge-control specifiers contain the keyword **edge** followed by a square-bracketed list of from one to six pairs of edge transitions between 0, 1, and x, as follows:

```
01   Transition from 0 to 1
0x   Transition from 0 to x
10   Transition from 1 to 0
1x   Transition from 1 to x
x0   Transition from x to 0
x1   Transition from x to 1
```

Edge transitions involving *z* are treated the same way as edge transitions involving *x*.

The **posedge** and **negedge** keywords can be used as a shorthand for certain edge-control specifiers. For example, the construct

```
posedge clr
```

is equivalent to the following:

```
edge[01, 0x, x1] clr
```

Similarly, the construct

```
negedge clr
```

is the same as the following:

```
edge[10, x0, 1x] clr
```

However, edge-control specifiers offer the flexibility to declare edge transitions other than **posedge** and **negedge**.

31.6 Notifiers: user-defined responses to timing violations

Timing check notifiers detect timing check violations behaviorally and, therefore, take an action as soon as a violation occurs. Such notifiers can be used to print an informative error message describing the violation or to propagate an *x* value at the output of the device that reported the violation.

The notifier is a variable, declared in the module where timing check tasks are invoked, that is passed as the last argument to a system timing check. Whenever a timing violation occurs, the timing check updates the value of the notifier.

The notifier is an optional argument to all system timing checks and can be omitted from the timing check call without adversely affecting its operation.

[Table 31-13](#) shows how the notifier values are toggled when timing violations occur.

Table 31-13—Notifier value responses to timing violations

BEFORE violation	AFTER violation
x	Either 0 or 1
0	1
1	0
z	z

Example 1

```
$setup( data, posedge clk, 10, notifier ) ;  
$width( posedge clk, 16, 0, notifier ) ;
```

Example 2—Consider a more complex example of how to use notifiers in a behavioral model. The following example uses a notifier to set the D flip-flop output to x when a timing violation occurs in an edge-sensitive UDP:

```

primitive posdff_udp(q, clock, data, preset, clear, notifier);
  output q; reg q;
  input clock, data, preset, clear, notifier;
  table
  //clock data  p c notifier state  q
  //-----
    r    0    1 1    ?    :  ?  : 0 ;
    r    1    1 1    ?    :  ?  : 1 ;

    p    1    ? 1    ?    :  1  : 1 ;
    p    0    1 ?    ?    :  0  : 0 ;

    n    ?    ? ?    ?    :  ?  : - ;
    ?    *    ? ?    ?    :  ?  : - ;

    ?    ?    0 1    ?    :  ?  : 1 ;
    ?    ?    * 1    ?    :  1  : 1 ;

    ?    ?    1 0    ?    :  ?  : 0 ;
    ?    ?    1 *    ?    :  0  : 0 ;
    ?    ?    ? ?    *    :  ?  : x ;// At any notifier event
                                     // output x

  endtable
endprimitive

module dff(q, qbar, clock, data, preset, clear);
  output q, qbar;
  input clock, data, preset, clear;
  reg notifier;

  and (enable, preset, clear);
  not (qbar, ffout);
  buf (q, ffout);
  posdff_udp (ffout, clock, data, preset, clear, notifier);

  specify
    // Define timing check specparam values
    specparam tSU = 10, tHD = 1, tPW = 25, tWPC = 10, tREC = 5;
    // Define module path delay rise and fall min:typ:max values
    specparam tPLHc = 4:6:9 , tPHLc = 5:8:11;
    specparam tPLHpc = 3:5:6 , tPHLpc = 4:7:9;

    // Specify module path delays
    (clock *> q,qbar) = (tPLHc, tPHLc);
    (preset,clear *> q,qbar) = (tPLHpc, tPHLpc);

    // Setup time : data to clock, only when preset and clear are 1
    $setup(data, posedge clock &&& enable, tSU, notifier);

    // Hold time: clock to data, only when preset and clear are 1
    $hold(posedge clock, data &&& enable, tHD, notifier);

    // Clock period check
  
```

```

    $period(posedge clock, tPW, notifier);
    // Pulse width : preset, clear
    $width(negedge preset, tWPC, 0, notifier);
    $width(negedge clear, tWPC, 0, notifier);

    // Recovery time: clear or preset to clock
    $recovery(posedge preset, posedge clock, tREC, notifier);
    $recovery(posedge clear, posedge clock, tREC, notifier);
  endspecify
endmodule

```

NOTE—This model applies to edge-sensitive UDPs only; for level-sensitive models, an additional UDP for \times propagation has to be generated.

31.7 Enabling timing checks with conditioned events

A construct called a *conditioned event* ties the occurrence of timing checks to the value of a conditioning signal. [Syntax 31-16](#) shows the syntax for controlled timing check events.

```

timing_check_event ::= // from A.7.5.3
    [timing_check_event_control] specify_terminal_descriptor [ &&& timing_check_condition ]
controlled_timing_check_event ::=
    timing_check_event_control specify_terminal_descriptor [ &&& timing_check_condition ]
timing_check_event_control ::=
    posedge
    | negedge
    | edge
    | edge_control_specifier
specify_terminal_descriptor ::=
    specify_input_terminal_descriptor
    | specify_output_terminal_descriptor
timing_check_condition ::=
    scalar_timing_check_condition
    | ( scalar_timing_check_condition )
scalar_timing_check_condition ::=
    expression
    | ~ expression
    | expression == scalar_constant
    | expression === scalar_constant
    | expression != scalar_constant
    | expression !== scalar_constant
scalar_constant ::= 1'b0 | 1'b1 | 1'B0 | 1'B1 | 'b0 | 'b1 | 'B0 | 'B1 | 1 | 0

```

Syntax 31-16—Syntax for controlled timing check events (excerpt from [Annex A](#))

The comparisons used in the condition can be deterministic, as in `===`, `!==`, `~`, or no operation, or nondeterministic, as in `==` or `!=`. When comparisons are deterministic, an \times value on the conditioning signal shall not enable the timing check. For nondeterministic comparisons, an \times on the conditioning signal shall enable the timing check.

The conditioning signal shall be a scalar net; if a vector net or an expression resulting in a multibit value is used, then the least significant bit of the vector net or the expression value is used.

If more than one conditioning signal is required for conditioning timing checks, appropriate logic shall be combined in a separate signal outside the specify block, which can be used as the conditioning signal.

Example 1—To illustrate the difference between conditioned and unconditioned timing check events, consider the following example with unconditioned timing check:

```
$setup( data, posedge clk, 10 );
```

Here, a setup timing check shall occur every time there is a positive edge on the signal `clk`.

To trigger the setup check on the positive edge on the signal `clk` only when the signal `clr` is high, rewrite the command as

```
$setup( data, posedge clk &&& clr, 10 );
```

Example 2—This example shows two ways to trigger the same timing check as in Example 1 (on the positive `clk` edge) only when `clr` is low. The second method uses the `===` operator, which makes the comparison deterministic.

```
$setup( data, posedge clk &&& (~clr), 10 );
$setup( data, posedge clk &&& (clr===0), 10 );
```

Example 3—To perform the previous sample setup check on the positive `clk` edge only when `clr` and `set` are high, add the following statement outside the specify block:

```
and new_gate( clr_and_set, clr, set );
```

Then add the condition to the timing check using the signal `clr_and_set` as follows:

```
$setup( data, posedge clk &&& clr_and_set, 10 );
```

31.8 Vector signals in timing checks

Either or both signals in a timing check can be a vector. This shall be interpreted as a single timing check where the transition of one or more bits of a vector is considered a single transition of that vector.

For example:

```
module DFF (Q, CLK, DAT);
  input CLK;
  input [7:0] DAT;
  output [7:0] Q;
  always @(posedge clk)
    Q = DAT;
  specify
    $setup (DAT, posedge CLK, 10);
  endspecify
endmodule
```

If `DAT` transitions from `'b00101110` to `'b01010011` at time 100 and if `CLK` transitions from 0 to 1 at time 105, then the `$setup` timing check shall still only report a single timing violation.

Simulators may provide an option causing vectors in timing checks to result in the creation of multiple single-bit timing checks. For timing checks with only a single signal, such as `$period` or `$width`, a vector of width `N` results in `N` unique timing checks. For timing checks with two signals, such as `$setup`, `$hold`,

$\$setuphold$, $\$skew$, $\$timeskew$, $\$fullskew$, $\$recovery$, $\$removal$, $\$recrem$, and $\$nochange$, where M and N are the widths of the signals, the result is $M*N$ unique timing checks. If there is a notifier, all the timing checks trigger that notifier.

With such an option enabled, the above example yields six timing violation because 6 bits of `DAT` transitioned.

31.9 Negative timing checks

Both the $\$setuphold$ and $\$recrem$ timing checks can accept negative values when the negative timing check option is enabled. The behavior of these two timing checks is identical with respect to negative values. The descriptions in this subclause are for the $\$setuphold$ timing check, but apply equally to the $\$recrem$ timing check.

The setup and hold timing check values define a timing violation window with respect to the reference signal edge during which the data shall remain constant. Any change of the data during the specified window causes a timing violation. The timing violation is reported, and through the notifier variable, other actions can take place in the model, such as forcing the output of a flip-flop to `x` when it detects a timing violation.

A positive value for both setup and hold times implies this violation window straddles the reference signal shown in [Figure 31-4](#).

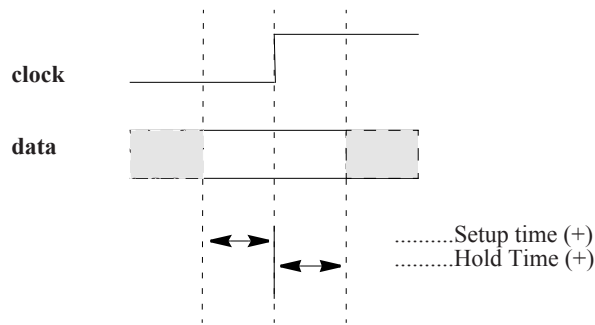

Figure 31-4—Data constraint interval, positive setup/hold

A negative hold or setup time means the violation window is shifted to either before or after the reference edge. This can happen in a real device because of disparate internal device delays between the internal clock and data signal paths. These internal device delays are illustrated in [Figure 31-5](#) showing how significant differences in these delays can cause negative setup or hold values.

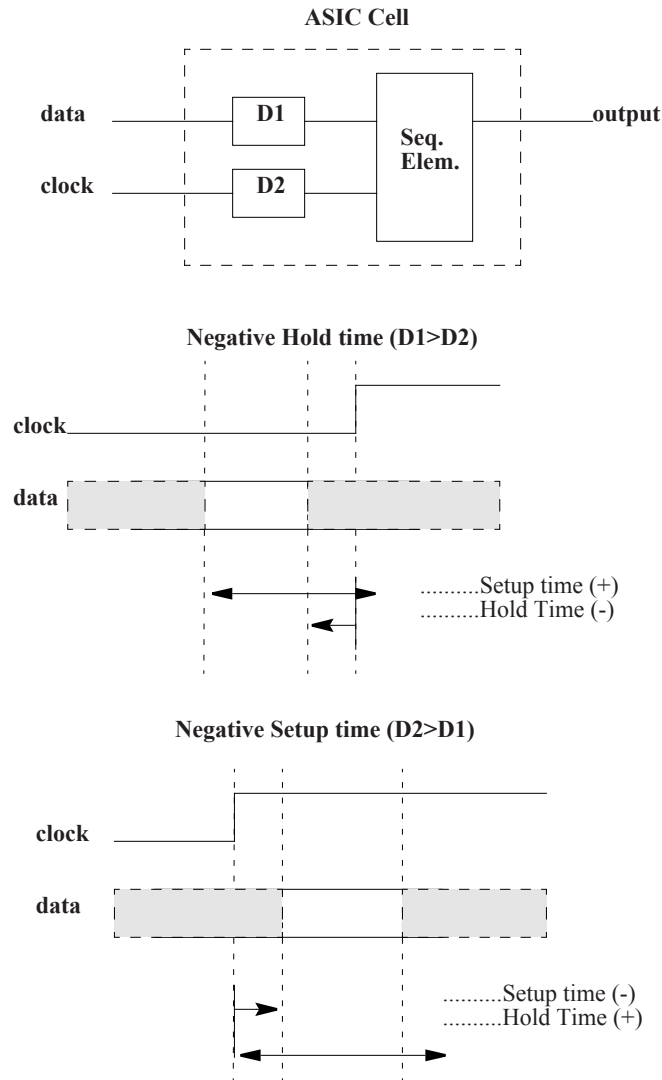

Figure 31-5—Data constraint interval, negative setup/hold

31.9.1 Requirements for accurate simulation

In order to accurately model negative value timing checks, the following requirements apply:

- a) A timing violation shall be triggered if the signal changes in the violation window, exclusive of the end points. Violation windows smaller than two units of simulation precision cannot yield timing violations.
- b) The value of the latched data shall be the one that is stable during the violation window, again, exclusive of the end points.

To facilitate these modeling requirements, delayed copies of the data and reference signals are generated in the timing checks, and these are used internally for timing check evaluation at run time. The setup and hold times used internally are adjusted to shift the violation window and make it overlap the reference signal.

Delayed data and reference signals can be declared within the timing check so they can be used in the model's functional implementation for more accurate simulation. If no delayed signals are declared in the

timing check and if a negative setup or hold value is present, then implicit delayed signals are created. Because implicit delayed signals cannot be used in defining model behavior, such a model can possibly behave incorrectly.

Example 1

```
$setuphold(posedge CLK, DATA, -10, 20);
```

Implicit delayed signals shall be created for CLK and DATA, but it shall not be possible to access them. The **\$setuphold** check shall be properly evaluated, but functional behavior shall not always be accurate. The old DATA value shall be incorrectly clocked in if DATA transitions between **posedge CLK** and 10 time units later.

Example 2

```
$setuphold(posedge CLK, DATA1, -10, 20);  
$setuphold(posedge CLK, DATA2, -15, 18);
```

Implicit delayed signals shall be created for CLK, DATA1, and DATA2, one for each. Even though CLK is referenced in two different timing checks, only one implicit delayed signal is created, and it is used for both timing checks.

Example 3—If a given signal has a delayed signal in some timing checks but not in others, the delayed signal shall be used in both cases:

```
$setuphold(posedge CLK, DATA1, -10, 20,,,, del_CLK, del_DATA1);  
$setuphold(posedge CLK, DATA2, -15, 18);
```

Explicit delayed signals of **del_CLK** and **del_DATA1** are created for CLK and DATA1, while an implicit delayed signal is created for DATA2. In other words, CLK has only one delayed signal created for it, **del_CLK**, rather than one explicit delayed signal for the first check and another implicit delayed signal for the second check.

The delayed versions of the signals, whether implicit or explicit, shall be used in the **\$setup**, **\$hold**, **\$setuphold**, **\$recovery**, **\$removal**, **\$recrem**, **\$width**, **\$period**, and **\$nochange** timing checks; and these checks shall have their limits adjusted accordingly so that the notifier shall be toggled at the proper moment. If the adjusted limit becomes less than or equal to 0, the limit shall be set to 0, and the simulator shall issue a warning.

The delayed versions of the signals shall not be used for the **\$skew**, **\$fullskew**, and **\$timeskew** timing checks because it can possibly result in the reversal of the order of signal transitions. This causes the notifiers for these timing checks to toggle at the wrong time relative to the rest of the model, perhaps resulting in transitions to x due to a timing check violation being cancelled. This issue shall be addressed in the model, possibly by using separate notifiers for these checks.

It is possible for a set of negative timing check values to be mutually inconsistent and produce no solution for the delay values of delayed signals. In these situations, the simulator shall issue a warning. The inconsistency shall be resolved by changing the smallest negative limit value to 0 and recalculating the delays for the delayed signals, and this shall be repeated until a solution is reached. This procedure shall always produce a solution because in the worst case all negative limit values become 0 and no delayed signals are needed.

The delayed timing check signals are only actually delayed when negative limit values are present. If a timing check signal becomes delayed by more than the propagation delay from that signal to an output, that

output shall take longer than its propagation delay to change. It shall instead transition at the same time that the delayed timing check signal changes. Thus, the output shall behave as if its specify path delay were equal to the delay applied to the timing check signal. This situation can only arise when unique setup/hold or removal/recovery times are given for each edge of the data signal.

For example:

```
(CLK = Q) = 6;
$setuphold (posedge CLK, posedge D, -3, 8, , , , dCLK, dD);
$setuphold (posedge CLK, negedge D, -7, 13, , , , dCLK, dD);
```

The setup time of -7 (the larger in absolute value of -3 and -7) creates a delay of 7 for `dCLK`; therefore, output `Q` shall not change until 7 time units after a positive edge on `CLK`, rather than the 6 time units given in the specify path.

31.9.2 Conditions in negative timing checks

Conditions can be associated with both the reference and data signals by using the `&&&` operator; but when either the setup or hold time is negative, the conditions need to be paired with reference and data signals in a more flexible way. This example illustrates why.

This pair of `$setup` and `$hold` checks works together to provide the same check as a single `$setuphold`:

```
$setup (data, clk &&& cond1, tsetup, ntfr);
$hold (clk, data &&& cond1, thold, ntfr);
```

`clk` is the timecheck event for the `$setup` check, while `data` is the timecheck event for the `$hold` check. This cannot be represented in a single `$setuphold` check; therefore, additional arguments are provided to make this possible. These arguments are `timestamp_condition` and `timecheck_condition`, and they immediately follow the notifier (see [31.3.3](#)). The following `$setuphold` check is equivalent to the separate `$setup` and `$hold` checks shown above:

```
$setuphold ( clk, data, tsetup, thold, ntfr, , cond1);
```

The `timestamp_condition` argument is null, while the `timecheck_condition` argument is `cond1`.

The `timestamp_condition` and `timecheck_condition` arguments are associated with either the reference or data signals based on which delayed version of these signals occurs first. `timestamp_condition` is associated with the delayed signal that transitions first, while `timecheck_condition` is associated with the delayed signal that transitions second.

Delayed signals are only created for the reference and data signals and not for any condition signals associated with them. Therefore, `timestamp_condition` and `timecheck_condition` are not implicitly delayed by the simulator. Delayed condition signals for the `timestamp_condition` and `timecheck_condition` fields can be created by making them a function of the delayed signals.

For example:

```
assign TE_cond_D = (dTE !== 1'b1);
assign TE_cond_TI = (dTE !== 1'b0);
assign DXTI_cond = (dTI !== dD);

specify
  $setuphold(posedge CP, D, -10, 20, notifier, ,TE_cond_D, dCP, dD);
  $setuphold(posedge CP, TI, 20, -10, notifier, ,TE_cond_TI, dCP, dTI);
```

```
$setuphold(posedge CP, TE, -4, 8, notifier, ,DXTI_cond, dCP, dTE);
endspecify
```

The assign statements create condition signals that are functions of the delayed signals. Creating delayed signal conditions synchronizes the conditions with the delayed versions of the reference and data signals used to perform the checks.

The first `$setuphold` has a negative setup time; therefore, the timecheck condition `TE_cond_D` is associated with data signal `D`. The second `$setuphold` has a negative hold time; therefore, the timecheck condition `TE_cond_TI` is associated with reference signals `CP`. The third `$setuphold` has a negative setup time; therefore, the timecheck condition `DXTI_cond` is associated with data signal `TE`.

The violation windows for the example are shown in [Figure 31-6](#).

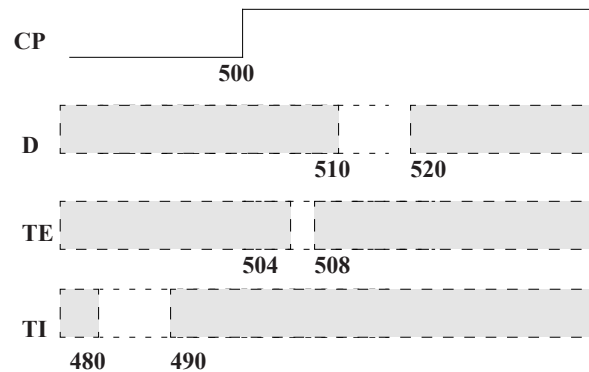

Figure 31-6—Timing check violation windows

These are the delay values calculated for the delayed signals:

dCP	10.01
dD	0.00
dTI	20.02
dTE	2.02

Use of delayed signals in creating the signals for the `timestamp_condition` and `timecheck_condition` arguments is not required, but it is usually closer to actual device behavior.

31.9.3 Notifiers in negative timing checks

Because the reference and data signals are delayed internally, the detection of the timing violation is also delayed. Notifier variables in negative timing checks shall be toggled when the timing check detects a timing violation, which occurs when the delayed signals as measured by the adjusted timing check values are in violation, not when the undelayed signals at the model inputs as measured by the original timing check values are in violation.

31.9.4 Option behavior

As already mentioned, the ability of simulators to handle negative values in `$setuphold` and `$recrem` timing checks shall be enabled with an invocation option. It is possible models written to accept negative timing check values with delayed reference and/or delayed data signals can be run without this invocation option enabled. In this circumstance, the delayed reference and data signals become copies of the original reference and data signals. The same occurs if an invocation option turning off all timing checks is used.

32. Backannotation using the standard delay format (SDF)

32.1 General

This clause describes the following:

- The SDF annotator
- Mapping SDF constructs to SystemVerilog
- Multiple annotations
- Multiple SDF files
- Pulse limit annotation
- SDF to SystemVerilog value mapping
- The `$sdf_annotate` SDF file reader

32.2 Overview

SDF files contain timing values for specify path delays, specparam values, timing check constraints, and interconnect delays. SDF files can also contain other information in addition to simulation timing, but these need not concern SystemVerilog simulation. The timing values in SDF files usually come from application-specific integrated circuit (ASIC) delay calculation tools that take advantage of connectivity, technology, and layout geometry information.

SystemVerilog backannotation is the process by which timing values from the SDF file update specify path delays, specparam values, timing constraint values, and interconnect delays.

All this information is covered further in IEEE Std 1497™-2001 [\[B1\]](#).

32.3 The SDF annotator

The term *SDF annotator* refers to any tool capable of backannotating SDF data to a SystemVerilog simulator. It shall issue a warning for any data it is unable to annotate.

An SDF file can contain many constructs that are not related to specify path delays, specparam values, timing check constraint values, or interconnect delays. An example is any construct in the `TIMINGENV` section of the SDF file. All constructs unrelated to SystemVerilog timing shall be ignored without any warnings issued.

Any SystemVerilog timing value for which the SDF file does not provide a value shall not be modified during the backannotation process, and its prebackannotation value shall be unchanged.

32.4 Mapping of SDF constructs to SystemVerilog

SDF timing values appear within a `CELL` declaration, which can contain one or more of `DELAY`, `TIMINGCHECK`, and `LABEL` sections. The `DELAY` section contains propagation delay values for specify paths and interconnect delays. The `TIMINGCHECK` section contains timing check constraint values. The `LABEL` section contains new values for specparams. Backannotation into SystemVerilog is done by matching SDF constructs to the corresponding SystemVerilog declarations and then replacing the existing SystemVerilog timing values with those from the SDF file.

32.4.1 Mapping of SDF delay constructs to SystemVerilog declarations

When annotating `DELAY` constructs that are not interconnect delays (covered in 32.4.4), the SDF annotator looks for specify paths where the names and conditions match. When annotating `TIMINGCHECK` constructs, the SDF annotator looks for timing checks of the same type where the names and conditions match. [Table 32-1](#) shows which SystemVerilog structures can be annotated by each SDF construct in the `DELAY` section.

Table 32-1—Mapping of SDF delay constructs to SystemVerilog declarations

SDF construct	SystemVerilog annotated structure
(PATHPULSE...	Conditional and nonconditional specify path pulse limits
(PATHPULSEPERCENT...	Conditional and nonconditional specify path pulse limits
(IOPATH...	Conditional and nonconditional specify path delays/pulse limits
(IOPATH (RETAIN...	Conditional and nonconditional specify path delays/pulse limits, RETAIN may be ignored
(COND (IOPATH...	Conditional specify path delays/pulse limits
(COND (IOPATH (RETAIN...	Conditional specify path delays/pulse limits, RETAIN may be ignored
(CONDELSE (IOPATH...	ifnone
(CONDELSE (IOPATH (RETAIN...	ifnone, RETAIN may be ignored
(DEVICE...	All specify paths to module outputs. If no specify paths, all primitives driving module outputs.
(DEVICE port_instance...	If port_instance is a module instance, all specify paths to module outputs. If no specify paths, all primitives driving module outputs. If port_instance is a module instance output, all specify paths to that module output. If no specify path, all primitives driving that module output.

In the following example, the source SDF signal `sel` matches the source SystemVerilog signal, and the destination SDF signal `zout` also matches the destination SystemVerilog signal. Therefore, the rise/fall times of 1.3 and 1.7 are annotated to the specify path.

SDF file:

```
(IOPATH sel zout (1.3) (1.7))
```

SystemVerilog specify path:

```
(sel => zout) = 0;
```

A conditional `IOPATH` delay between two ports shall annotate only to SystemVerilog specify paths between those same two ports with the same condition. In the following example, the rise/fall times of 1.3 and 1.7 are annotated only to the second specify path:

SDF file:

```
(COND mode (IOPATH sel zout (1.3) (1.7)))
```

SystemVerilog specify paths:

```
if (!mode) (sel => zout) = 0;
if (mode) (sel => zout) = 0;
```

A nonconditional IOPATH delay between two ports shall annotate to all SystemVerilog specify paths between those same two ports. In the following example, the rise/fall times of 1.3 and 1.7 are annotated to both specify paths:

SDF file:

```
(IOPATH sel zout (1.3) (1.7))
```

SystemVerilog specify paths:

```
if (!mode) (sel => zout) = 0;
if (mode) (sel => zout) = 0;
```

32.4.2 Mapping of SDF timing check constructs to SystemVerilog

Table 32-2 shows which SystemVerilog timing checks are annotated to by each type of SDF timing check. v1 is the first value of a timing check, v2 is the second value, while x indicates no value is annotated.

Table 32-2—Mapping of SDF timing check constructs to SystemVerilog

SDF timing check	Annotated SystemVerilog timing checks
(SETUP v1...	\$setup(v1), \$setuphold(v1,x)
(HOLD v1...	\$hold(v1), \$setuphold(x,v1)
(SETUPHOLD v1 v2...	\$setup(v1), \$hold(v2), \$setuphold(v1,v2)
(RECOVERY v1...	\$recovery(v1), \$recrem(v1,x)
(REMOVAL v1...	\$removal(v1), \$recrem(x,v1)
(RECREM v1 v2...	\$recovery(v1), \$removal(v2), \$recrem(v1,v2)
(SKEW v1...	\$skew(v1), \$timeskew(v1)
(BIDIRECTSKEW v1 v2...	\$fullskew(v1,v2)
(WIDTH v1...	\$width(v1,x)
(PERIOD v1...	\$period(v1)
(NOCHANGE v1 v2...	\$nochange(v1,v2)

The reference and data signals of timing checks can have logical condition expressions and edges associated with them. An SDF timing check with no conditions or edges on any of its signals shall match all corresponding SystemVerilog timing checks regardless of whether conditions are present. In the following example, the SDF timing check shall annotate to all the SystemVerilog timing checks:

SDF file:

```
(SETPHOLD data clk (3) (4))
```

SystemVerilog timing checks:

```
$setuphold (posedge clk &&& mode, data, 1, 1, ntf);
```



```
$setuphold (negedge clk &&& !mode, data, 1, 1, ntfr);
$setuphold (edge clk, data, 1, 1, ntfr);
```

When conditions and/or edges are associated with the signals in an SDF timing check, then they shall match those in any corresponding SystemVerilog timing check before annotation shall happen. In the following example, the SDF timing check shall annotate to the first SystemVerilog timing check, but not the second and the third:

SDF file:

```
(SETUPHOLD data (posedge clk) (3) (4))
```

SystemVerilog timing checks:

```
$setuphold (posedge clk &&& mode, data, 1, 1, ntfr); // Annotated
$setuphold (negedge clk &&& !mode, data, 1, 1, ntfr); // Not annotated
$setuphold (edge clk, data, 1, 1, ntfr); // Not annotated
```

Here, the SDF timing check shall not annotate to any of the SystemVerilog timing checks.

SDF file:

```
(SETUPHOLD data (COND !mode (posedge clk)) (3) (4))
```

SystemVerilog timing checks:

```
$setuphold (posedge clk &&& mode, data, 1, 1, ntfr); // Not annotated
$setuphold (negedge clk &&& !mode, data, 1, 1, ntfr); // Not annotated
$setuphold (edge clk, data, 1, 1, ntfr); // Not annotated
```

32.4.3 SDF annotation of specparams

The SDF LABEL construct annotates to specparams. Any expression containing one or more specparams is reevaluated when annotated to from an SDF file.

The following example shows SDF LABEL constructs annotating to specparams in a SystemVerilog module. The specparams are used in procedural delays to control when the clock transitions. The SDF LABEL construct annotates the values of dhigh and dlow, thereby setting the period and duty cycle of the clock.

SDF file:

```
(LABEL
  (ABSOLUTE
    (dhigh 60)
    (dlow 40)))
```

SystemVerilog file:

```
module clock(clk);
  output clk;
  reg clk;
  specparam dhigh=0, dlow=0;
  initial clk = 0;
  always
  begin
    #dhigh clk = 1; // Clock remains low for time dlow
```

```

// before transitioning to 1
#dlow  clk = 0; // Clock remains high for time dhigh
// before transitioning to 0
end
endmodule

```

The following example shows a `specparam` in an expression of a `specify` path. The `SDF LABEL` construct can be used to change the value of the `specparam` and cause reevaluation of the expression.

```

specparam cap = 0;
...
specify
(A => Z) = 1.4 * cap + 0.7;
endspecify

```

32.4.4 SDF annotation of interconnect delays

SDF interconnect delay annotation differs from annotation of other constructs described above in that there exists no corresponding SystemVerilog declaration to which to annotate. In SystemVerilog simulation, interconnect delays are an abstraction that represents the signal propagation delay from an output or inout module port to an input or inout module port. The `INTERCONNECT` construct includes a source, a load, and delay values, while the `PORT` and `NETDELAY` constructs include only a load and delay values. Interconnect delays can only be annotated between module ports, never between primitive pins. [Table 32-3](#) shows how the SDF interconnect constructs in the `DELAY` section are annotated.

Table 32-3—SDF annotation of interconnect delays

SDF construct	SystemVerilog annotated structure
(PORT...	Interconnect delay
(NETDELAY ^a	Interconnect delay
(INTERCONNECT...	Interconnect delay

^aOnly OVI SDF version 1.0, 2.0, and 2.1 and IEEE SDF version 4.0

Interconnect delays can be annotated to both single source and multisource nets.

When annotating a `PORT` construct, the SDF annotator shall search for the port and, if it exists, shall annotate an interconnect delay to that port that shall represent the delay from all sources on the net to that port.

When annotating a `NETDELAY` construct, the SDF annotator shall check to see if it is annotating to a port or a net. If it is a port, then the SDF annotator shall annotate an interconnect delay to that port. If it is a net, then it shall annotate an interconnect delay to all load ports connected to that net. If the port or net has more than one source, then the delay shall represent the delay from all sources. `NETDELAY` delays can only be annotated to input or inout module ports or to nets.

In the case of multisource nets, unique delays can be annotated between each source/load pair using the `INTERCONNECT` construct. When annotating this construct, the SDF annotator shall find the source port and the load port; and if both exist, it shall annotate an interconnect delay between the two. If the source port is not found or if the source port and the load port are not actually on the same net, then a warning is issued, but the delay to the load port is annotated anyway. If this happens for a load port that is part of a multisource net, then the delay is treated as if it were the delay from all source ports, which is the same as the annotation behavior for a `PORT` delay. Source ports shall be output or inout ports, while load ports shall be input or inout ports.

Interconnect delays share many of the characteristics of specify path delays. The same rules for specify path delays for filling in missing delays and pulse limits also apply for interconnect delays. Interconnect delays have twelve transition delays, and unique reject and error pulse limits are associated with each of the twelve. An unlimited number of future schedules are permitted.

In a SystemVerilog module, a reference to an annotated port, wherever it occurs, whether in `$monitor` and `$display` statements or in expressions, shall provide the delayed signal value. A reference to the source shall yield the undelayed signal value, while a reference to the load shall yield the delayed signal value. In general, references to the signal value hierarchically before the load shall yield the undelayed signal value, while references to the signal at or hierarchically after the load shall yield the delayed signal value. An annotation to a hierarchical port shall affect all connected ports at higher or lower hierarchical levels, depending on the direction of annotation. An annotation from a source port shall be interpreted as being from all sources hierarchically higher or lower than that source port.

Up-hierarchy annotations shall be properly handled. This situation arises when the load is hierarchically above the source. The delay to all ports that are hierarchically above the load or that connect to the net at points hierarchically above the load is the same as the delay to that load.

Down-hierarchy annotation shall also be properly handled. This situation arises when the source is hierarchically above the load. The delay to the load is interpreted as being from all ports that are at or above the source or that connect to the net at points hierarchically above the source.

Hierarchically overlapping annotations are permitted. This occurs when annotations to or from the same port take place at different hierarchical levels and, therefore, do not correspond to the same hierarchical subset of ports. In the following example, the first `INTERCONNECT` statement annotates to all ports of the net that are at or hierarchically within `i53/selmode`, while the second annotates to a smaller subset of ports, only those at or hierarchically within `i53/u21/in`:

```
(INTERCONNECT i14/u5/out i53/selmode (1.43) (2.17))  
(INTERCONNECT i14/u5/out i53/u21/in (1.58) (1.92))
```

Overlapping annotations can occur in many different ways, particularly on multisource/multiload nets, and SDF annotation shall properly resolve all the interactions.

32.5 Multiple annotations

SDF annotation is an ordered process. The constructs from the SDF file are annotated in their order of occurrence. In other words, annotation of an SDF construct can be changed by annotation of a subsequent construct that either modifies (`INCREMENT`) or overwrites (`ABSOLUTE`) it. These do not have to be the same construct. The following example first annotates pulse limits to an `IOPATH` and then annotates the entire `IOPATH`, thereby overwriting the pulse limits that were just annotated:

```
(DELAY  
  (ABSOLUTE  
    (PATHPULSE A Z (2.1) (3.4))  
    (IOPATH A Z (3.5) (6.1))
```

Overwriting the pulse limits can be avoided by using empty parentheses to hold the current values of the pulse limits:

```
(DELAY  
  (ABSOLUTE  
    (PATHPULSE A Z (2.1) (3.4))  
    (IOPATH A Z ((3.5) () ()) ((6.1) () ()))
```

The above annotation can be simplified into a single statement as follows:

```
(DELAY
  (ABSOLUTE
    (IOPATH A Z ((3.5) (2.1) (3.4)) ((6.1) (2.1) (3.4)) )
```

A `PORT` annotation followed by an `INTERCONNECT` annotation to the same load shall cause only the delay from the `INTERCONNECT` source to be affected. For the following net with three sources and a single load, the delay from all sources except `i13/out` remains 6:

```
(DELAY
  (ABSOLUTE
    (PORT i15/in (6))
    (INTERCONNECT i13/out i15/in (5))
```

An `INTERCONNECT` annotation followed by a `PORT` annotation shall cause the `INTERCONNECT` annotation to be overwritten. Here, the delays from all sources to the load shall become 6:

```
(DELAY
  (ABSOLUTE
    (INTERCONNECT i13/out i15/in (5))
    (PORT i15/in (6))
```

32.6 Multiple SDF files

More than one SDF file can be annotated. Each call to the `$sdf_annotate` task annotates the design with timing information from an SDF file. Annotated values either modify (`INCREMENT`) or overwrite (`ABSOLUTE`) values from earlier SDF files. Different regions of a design can be annotated from different SDF files by specifying the region's hierarchy scope as the second argument to `$sdf_annotate`.

32.7 Pulse limit annotation

For SDF annotation of delays (not timing constraints), the default values annotated for pulse limits shall be calculated using the percentage settings for the reject and error limits. By default, these limits are 100%, but they can be modified through invocation options. For example, assuming invocation options have set the reject limit to 40% and the error limit to 80%, the following SDF construct shall annotate a delay of 5, a reject limit of 2, and an error limit of 4:

```
(DELAY
  (ABSOLUTE
    (IOPATH A Z (5))
```

Given that the specify path delay was originally 0, the following annotation results in a delay of 5 and pulse limits of 0:

```
(DELAY
  (ABSOLUTE
    (IOPATH A Z ((5) () ()) )
```

Annotations in `INCREMENT` mode can result in pulse limits less than 0, in which case they shall be adjusted to 0. For example, if the specify path pulse limits were both 3, the following annotation results in a 0 value for both pulse limits:

```
(DELAY
  (INCREMENT
```

(IOPATH A Z ((-4) (-5)))

There are two SDF constructs that annotate only to pulse limits, `PATHPULSE` and `PATHPULSEPERCENT`. They do not affect the delay. When `PATHPULSE` sets the pulse limits to values greater than the delay, SystemVerilog shall exhibit the same behavior as if the pulse limits had been set equal to the delay.

32.8 SDF to SystemVerilog delay value mapping

SystemVerilog specify paths and interconnects can have unique delays for up to twelve state transitions (see [30.5.1](#)). All other constructs, such as gate primitives and continuous assignments, can have only three state transition delays (see [28.16](#)).

For SystemVerilog specify path and interconnect delays, the number of transition delay values provided by SDF might be less than twelve.

[Table 32-4](#) shows how fewer than twelve SDF delays are extended to be twelve delays. The SystemVerilog transition types are shown down the left-hand side, while the number of SDF delays provided is shown across the top. The SDF values are given the names `v1` through `v12`.

Table 32-4—SDF to SystemVerilog delay value mapping

SystemVerilog transition	Number of SDF delay values provided				
	1 value	2 values	3 values	6 values	12 values
0 -> 1	v1	v1	v1	v1	v1
1 -> 0	v1	v2	v2	v2	v2
0 -> z	v1	v1	v3	v3	v3
z -> 1	v1	v1	v1	v4	v4
1 -> z	v1	v2	v3	v5	v5
z -> 0	v1	v2	v2	v6	v6
0 -> x	v1	v1	min(v1,v3)	min(v1,v3)	v7
x -> 1	v1	v1	v1	max(v1,v4)	v8
1 -> x	v1	v2	min(v2,v3)	min(v2,v5)	v9
x -> 0	v1	v2	v2	max(v2,v6)	v10
x -> z	v1	max(v1,v2)	v3	max(v3,v5)	v11
z -> x	v1	min(v1,v2)	min(v1,v2)	min(v4,v6)	v12

For other delays that can have at most three values, the expansion of less than three SDF delays into three SystemVerilog delays is covered in [Table 28-9](#). More than three SDF delays are reduced to three SystemVerilog delays by simply ignoring the extra delays. The delay to the x-state is created from the minimum of the other three delays.

32.9 Loading timing data from an SDF file

The syntax for the `$sdf_annotate` system task is shown in [Syntax 32-1](#).

```
sdf_annotate_task ::=
    $sdf_annotate ( sdf_file [ , [ module_instance ] [ , [ "config_file" ]
        [ , [ "log_file" ] [ , [ "mtm_spec" ]
            [ , [ "scale_factors" ] [ , [ "scale_type" ] ] ] ] ] ] ) ;
```

Syntax 32-1—Syntax for \$sdf_annotate system task (not in [Annex A](#))

The \$sdf_annotate system task reads timing data from an SDF file into a specified region of the design.

sdf_file—Is an expression that is a string literal, **string** data type, or an integral data type containing a character string that names the file to be opened.

module_instance—is an optional argument specifying the scope to which to annotate the information in the SDF file. The SDF annotator uses the hierarchy level of the specified instance for running the annotation. Array indices are permitted. If the *module_instance* is not specified, the SDF annotator uses the module containing the call to the \$sdf_annotate system task as the *module_instance* for annotation.

config_file—is an optional character string argument providing the name of a configuration file. Information in this file can be used to provide detailed control over many aspects of annotation.

log_file—is an optional character string argument providing the name of the log file used during SDF annotation. Each individual annotation of timing data from the SDF file results in an entry in the log file.

mtm_spec—is an optional character string argument specifying which member of the min/typ/max triples shall be annotated. The legal values for this string are described in [Table 32-5](#). This overrides any MTM_SPEC keywords in the configuration file.

Table 32-5—mtm_spec argument

Keyword	Description
MAXIMUM	Annotates the maximum value
MINIMUM	Annotates the minimum value
TOOL_CONTROL (default)	Annotates the value as selected by the simulator
TYPICAL	Annotates the typical value

scale_factors—is an optional character string argument specifying the scale factors to be used while annotating timing values. For example, "1.6:1.4:1.2" causes minimum values to be multiplied by 1.6, typical values by 1.4, and maximum values by 1.2. The default values are 1.0:1.0:1.0. The *scale_factors* argument overrides any SCALE_FACTORS keywords in the configuration file.

scale_type—is an optional character string argument specifying how the scale factors should be applied to the min/typ/max triples. The legal values for this string are shown in [Table 32-6](#). This overrides any `SCALE_TYPE` keywords in the configuration file.

Table 32-6—scale_type argument

Keyword	Description
FROM_MAXIMUM	Applies scale factors to maximum value
FROM_MINIMUM	Applies scale factors to minimum value
FROM_MTM (default)	Applies scale factors to min/typ/max values
FROM_TYPICAL	Applies scale factors to typical value

33. Configuring the contents of a design

33.1 General

This clause describes the following:

- Configuration libraries
- Configuration syntax
- Using libraries and configurations

33.2 Overview

To facilitate both the sharing of SystemVerilog designs between designers and/or design groups and the repeatability of the exact contents of a given simulation (or other tool) session, the concept of *configurations* is used in the SystemVerilog language. A configuration is simply an explicit set of rules to specify the exact source description to be used to represent each instance in a design. The operation of selecting a source representation for an instance is referred to as *binding* the instance.

The following example shows a simple configuration problem:

```

file top.v                file adder.v                file adder.vg
module top();
  adder a1(...);
  adder a2(...);
endmodule

module adder(...);
  // rtl adder
  // description
  ...
endmodule

module adder(...);
  // gate-level adder
  // description
  ...
endmodule

```

Consider using the `rtl adder` description in `adder.v` for instance `a1` in module `top` and the `gate-level adder` description in `adder.vg` for instance `a2`. In order to specify this particular set of instance bindings and to avoid having to change the source description to specify a new set, a configuration can be used.

```

config cfg1; // specify rtl adder for top.a1, gate-level adder for top.a2
  design rtlLib.top;
  default liblist rtlLib;
  instance top.a2 liblist gateLib;
endconfig

```

The elements of a *config* are explained in subsequent subclauses, but this simple example illustrates some important points about *configs*. As evidenced by the `config–endconfig` syntax, the config is a design element, similar to a module, which exists in the SystemVerilog name space. The config contains a set of rules that are applied when searching for a source description to bind to a particular instance of the design.

A design description starts with a top-level module (or modules) (see [23.3.1](#)). From this module's source description, the instantiated modules (or children) are found, then the source descriptions for the module definitions of these subinstances shall be located, and so on until every instance in the design is mapped to a source description.

33.2.1 Library notation

A library is a named collection of *cells*. A cell is a *design element* (see [3.2](#)), such as a module, primitive, interface, program, package, or configuration. The cell name shall be the same as the name of the design element being processed.

In order to map a design element instance to a source description, the concept of a symbolic *library*, which is simply a logical collection of design elements, can be used. [Syntax 33-1](#) specifies a cell from a given library.

```
cell_clause ::= cell [ library_identifier . ] cell_identifier //from A.1.5
```

Syntax 33-1—Syntax for cell (excerpt from [Annex A](#))

This notation gives a symbolic method of referring to source descriptions; the method of mapping source descriptions into libraries is shown in greater detail in [33.3.1](#). The optional `:config` extension shall be used explicitly to refer to a config in the case where a config has the same name as a module/primitive.

For the purposes of this example, suppose the files `top.v` and `adder.v` (i.e., the RTL descriptions) have been mapped into the library `rtlLib` and the file `adder.vg` (i.e., the gate-level description of the `adder`) has been mapped into the library `gateLib`. The actual mechanism for mapping source descriptions to libraries is detailed in [33.3](#).

33.2.2 Basic configuration elements

The **design** statement in `config cfg1` of the first example of [33.2](#) specifies the top-level module in the design and what source description is to be used. In this example, the `rtlLib.top` notation indicates the top-level module description shall be taken from `rtlLib`. Because `top.v` and `adder.v` were mapped to this library, the actual description for the module is known to come from `top.v`.

The **default** statement coupled with the **liblist** clause specifies, by default, all subinstances of `top` (i.e., `top.a1` and `top.a2`) shall be taken from `rtlLib`, which means the descriptions in `top.v` and `adder.v`, which were mapped to this library, shall be used. For a basic design, which can be completely `rtl`, this can be sufficient to specify completely the binding for the entire design. However, here the `top.a2` instance of `adder` to the gate-level description shall be bound.

The **instance** statement specifies, for the particular instance `top.a2`, the source description shall be taken from `gateLib`. The instance statement overrides the default rule for this particular instance. Because `adder.vg` was mapped to `gateLib`, this statement dictates the gate-level description in `adder.vg` be used for instance `top.a2`.

33.3 Libraries

As mentioned in the previous subclause, a library is a logical collection of cells that are mapped to particular source description files. The symbolic `lib.cell[:config]` notation supports the separate compilation of source files by providing a file-system-independent name to refer to source descriptions when instances in a design are bound. It also allows multiple tools, which can have different invocation use models, to share the same configuration.

33.3.1 Specifying libraries—the library map file

When parsing a source description file (or files), the parser shall first read the library mapping information from a predefined file prior to reading any source files. The name of this file and the mechanism for reading it shall be tool-specific, but all compliant tools shall provide a mechanism to specify one or more library map files to be used for a particular invocation of the tool. If multiple map files are specified, then they shall be read in the order in which they are specified.

For the purposes of this discussion, assume the existence of a file named `lib.map` in the current working directory, which is automatically read by the parser prior to parsing any source files specified on the command line. The syntax for declaring a library in the library map file is shown in [Syntax 33-2](#).

```

library_text ::= { library_description } //from A.1.1
library_description ::=
    library_declaration
  | include_statement
  | config_declaration
  | ;
library_declaration ::=
    library library_identifier file_path_spec { , file_path_spec }
    [ -incdir file_path_spec { , file_path_spec } ] ;
include_statement ::= include file_path_spec ;

```

Syntax 33-2—Syntax for declaring library in library map file (excerpt from [Annex A](#))

Library map file details

- 1) `file_path_spec` uses file-system-specific notation to specify an absolute or relative path to a particular file or set of files. The following shortcuts/wildcards can be used:

?	single character wildcard (matches any single character)
*	multiple character wildcard (matches any number of characters in a directory/file name)
...	hierarchical wildcard (matches any number of hierarchical directories)
..	specifies the parent directory
.	specifies the directory containing the <code>lib.map</code>

Paths that end in `/` shall include all files in the specified directory. Identical to `/*`.

Paths that do not begin with `/` are relative to the directory in which the current `lib.map` file is located.

- 2) The paths `/*.*.v` and `*.v` are identical, and both specify all files with a `.v` suffix in the current directory.

Any file encountered by the compiler that does not match any library's `file_path_spec` shall by default be compiled into a library named `work`.

To perform the library mapping discussed in the example in [33.2](#), use the following library definitions in the `lib.map` file:

```

library rtlLib *.v;      // matches all files in the current directory with
                        // a .v suffix
library gateLib ./*.vg; // matches all files in the current directory with
                        // a .vg suffix

```

33.3.1.1 File path resolution

If a file name potentially matches multiple file path specifications, the path specifications shall be resolved in the following order:

- a) File path specifications that end with an explicit filename
- b) File path specifications that end with a wildcarded filename
- c) File path specifications that end with a directory

If a file name matches path specifications in multiple library definitions (after the above resolution rules have been applied), it shall be an error.

Using these rules with the library definitions in the `lib.map` file, all source files encountered by the parser/compiler can be mapped to a unique library. Once the source descriptions have been mapped to libraries, the cells defined in those libraries are available for binding.

NOTE—Tool implementers may find it convenient to provide a command-line argument to explicitly specify the library into which the file being parsed is to be mapped, which shall override any library definitions in the `lib.map` file. If these libraries do not exist in the `lib.map` file, they can only be accessed via an explicit config.

If multiple cells with the same name map to the same library, then the last cell encountered shall be written to the library. This is to support a “separate-compile” use model (see [33.5.3](#)), where it is assumed that encountering a cell after it has previously been compiled is intended to be a recompiling of the cell. In the case where multiple modules with the same name are mapped to the same library in a single invocation of the compiler, then a warning shall be issued.

33.3.2 Using multiple library map files

In addition to specifying library mapping information, a `lib.map` file can also include references to other `lib.map` files. The `include` command is used to insert the entire contents of a library map file in another file during parsing. The result is as though the contents of the included map file appear in place of the `include` command.

The syntax of a `lib.map` file is limited to library specifications, include statements, and standard SystemVerilog comment syntax. [Syntax 33-3](#) shows the syntax for the `include` command.

```
include_statement ::= include file_path_spec ; //from A.1.1
```

Syntax 33-3—Syntax for include command (excerpt from [Annex A](#))

If the file path specification, whether in an include or library statement, describes a relative path, it shall be relative to the location of the file that contains the file path. Library providers shall include a local library map file in addition to the source contents of the library. Individual users can then simply include the provider’s library map file in their own map file to gain access to the contents of the provided library.

33.3.3 Mapping source files to libraries

For each cell definition encountered during parsing/compiling, the name of the source file being parsed is compared to the file path specifications of the library declarations in all of the library map files being used. The cell is mapped into the library whose file path specification matches the source file name.

33.4 Configurations

As mentioned in the introduction of this clause, a configuration is simply a set of rules to apply when searching for library cells to which to bind instances.

A configuration may change the binding of a module, primitive, interface, or program instance, but shall not change the binding of a package.

The syntax for configurations is shown in [33.4.1](#).

33.4.1 Basic configuration syntax

The configuration syntax is shown in [Syntax 33-4](#).

```

config_declaration ::= //from A.1.5
    config config_identifier ;
    { local_parameter_declaration ; }
    design_statement
    { config_rule_statement }
    endconfig [ : config_identifier ]

design_statement ::= design { [ library_identifier . ] cell_identifier } ;

config_rule_statement ::=
    default_clause liblist_clause ;
    | inst_clause liblist_clause ;
    | inst_clause use_clause ;
    | cell_clause liblist_clause ;
    | cell_clause use_clause ;

default_clause ::= default
inst_clause ::= instance inst_name
inst_name ::= topmodule_identifier { . instance_identifier }
cell_clause ::= cell [ library_identifier . ] cell_identifier
liblist_clause ::= liblist {library_identifier}
use_clause ::= use [ library_identifier . ] cell_identifier [ : config ]
    | use named_parameter_assignment { , named_parameter_assignment } [ : config ]
    | use [ library_identifier . ] cell_identifier named_parameter_assignment
    { , named_parameter_assignment } [ : config ]

```

Syntax 33-4—Syntax for configurations (excerpt from [Annex A](#))

33.4.1.1 Design statement

The **design** statement names the library and cell of the top-level module or modules in the design hierarchy configured by the config. There shall be one and only one design statement, but multiple top-level modules can be listed in the design statement. The cell or cells identified cannot be configurations themselves. It is possible the design identified can have the same name as configs, however.

The **design** statement shall appear before any config rule statements in the config.

If the library identifier is omitted, then the library that contains the config shall be used to search for the cell.

33.4.1.2 The default clause

The **default** clause selects all instances that do not match a more specific selection clause. The **use** expansion clause (see [33.4.1.6](#)) cannot be used with a **default** selection clause. For other expansion clauses, there cannot be more than one **default** clause that specifies the expansion clause.

For simple design configurations, it might be sufficient to specify a **default liblist** (see [33.4.1.5](#)).

33.4.1.3 The instance clause

The **instance** clause is used to specify the specific instance to which the expansion clause shall apply. The instance name associated with the **instance** clause is a SystemVerilog hierarchical name, starting at the top-level module of the config (i.e., the name of the cell in the **design** statement).

33.4.1.4 The cell clause

The **cell** selection clause names the cell to which it applies. If the optional library name is specified, then the selection rule applies to any instance that is bound or is under consideration for being bound to the selected library and cell. It is an error if a library name is included in a **cell** selection clause and the corresponding expansion clause is a library list expansion clause.

33.4.1.5 The liblist clause

The **liblist** clause defines an ordered set of libraries to be searched to find the current instance. *liblists* are inherited hierarchically downward as instances are bound. When searching for a cell to bind to the current unbound instance, and in the absence of an applicable binding expansion clause, the specified library list is searched in the specified order.

The current library list is selected by the selection clauses. If no library list clause is selected or if the selected library list is empty, then the library list contains the single name that is the library in which the cell containing the unbound instance is found (i.e., the parent cell's library).

33.4.1.6 The use clause

The **use** clause specifies a specific binding for the selected cell. A **use** clause can only be used in conjunction with an **instance** or **cell** selection clause. It specifies the exact library and cell to which a selected cell or instance is bound.

The **use** clause has no effect on the current value of the library list. It can be common in practice to specify multiple config rule statements, one of which specifies a binding and the other of which specifies a library list.

If the **lib.cell** to which the **use** clause refers is a config that has the same name as a module/primitive in the same library, then the optional **:config** suffix can be added to the **lib.cell** to specify the config explicitly.

If the library name is omitted, the library shall be inherited from the parent cell.

NOTE—The binding statement can create situations where the unbound instance's module name and the cell name to which it is bound are different.

33.4.2 Hierarchical configurations

For situations where it is desirable to specify a special set of configuration rules for a subsection of a design, it is possible to bind a particular instance directly to a configuration using the binding clause:

```
instance top.a1.c use lib1.c:config;  
// bind to the config c in library lib1
```

specifies the instance **top.a1.c** is to be replaced with the design hierarchy specified by the configuration **lib1.c:config**. The **design** statement in **lib1.c:config** shall specify the actual binding for the instance **top.a1.c**, and the rules specified in the config shall determine the configuration of all other substances under **top.a1.c**.

It shall be an error for an instance clause to specify a hierarchical path to an instance that occurs within a hierarchy specified by another config.

```

config bot;
  design lib1.bot;
  default liblist lib1 lib2;
  instance bot.a1 liblist lib3;
endconfig

config top;
  design lib1.top;
  default liblist lib2 lib1;
  instance top.bot use lib1.bot:config;
  instance top.bot.a1 liblist lib4;
  // ERROR - cannot set liblist for top.bot.a1 from this config
endconfig

```

33.4.3 Setting parameters in configurations

Configurations can be used to override parameters declared within a design, or to apply or override parameter values for specific instantiations of a design. When a common value is desired for overriding a number of parameters in a configuration, a localparam can be declared in the configuration.

The following is a list of detailed restrictions regarding setting parameters from a configuration:

- A localparam declared in a configuration must be assigned a value and shall only be set to a literal value.
- Index expressions in a hierarchical name shall only refer to literals or localparams of the configuration.
- Parameter identifiers shall be resolved starting in the parent scope of the instance. If a hierarchical identifier is used, it must be the only term in the expression, e.g., a.b.c + 7 is invalid.
- Parameter identifiers that bind into the parent of the configured instance shall be identifiers that are legal in a bind statement.
- Hierarchical references cannot include scopes of generate or array of instances.
- A parameter override in a configuration shall not refer to a constant function other than a built-in constant system function.
- A parameter override from a configuration shall take precedence over a defparam statement when both are referencing the same parameter at the same level of hierarchy. In all other conditions, defparam statements work as defined.
- Configurations may not use positional parameter notation to override parameters.

The following two code sample modules are used by examples in this subclause. Note that module top includes an instantiation of adder and does not include any direct parameter modifications.

```

module adder #(parameter ID = "id",
                W = 8,
                D = 512)
    (...);
    ...
    $display("ID = %s, W = %d, D = %d", ID, W, D);
    ...
endmodule: adder

```

Example 1

```
module top (...);  
  parameter WIDTH = 16;  
  adder a1 (...);  
endmodule
```

Example 2

The code above, without any parameter overrides on adder a1, will print the following:

```
ID = id, W=8, D = 512
```

A configuration can be used to override a parameter in a module and apply that overridden parameter to instantiations within that module. The configuration in Example 3 overrides the default value of parameter WIDTH in module top shown in Example 2. Example 3 then uses parameter WIDTH to override the parameter for the instantiation of adder. (The code for adder is found in Example 1.)

```
config cfg1;  
  design rtlLib.top;  
  instance top use #(.WIDTH(32));  
  instance top.a1 use #(.W(top.WIDTH));  
endconfig
```

Example 3

Using configuration cfg1 above, the \$display in adder will print the following:

```
ID = id, W=32, D = 512
```

A localparam can be used in a configuration to represent a value sent to multiple instances.

```
module top4 ();  
  parameter S = 16;  
  adder a1 #(.ID("a1")) (...);  
  adder a2 #(.ID("a2")) (...);  
  adder a3 #(.ID("a3")) (...);  
  adder a4 #(.ID("a4")) (...);  
endmodule  
  
config cfg2;  
  localparam S = 24;  
  design rtlLib.top4;  
  instance top4.a1 use #(.W(top4.S));  
  instance top4.a2 use #(.W(S));  
endconfig
```

Example 4

With cfg2 configuring module top4.a1, the \$display in adder will print the following:

```
ID = a1, W=16, D = 512  
ID = a2, W=24, D = 512  
ID = a3, W=8, D = 512  
ID = a4, W=8, D = 512
```

In Example 4, the override of adder port ID in top4 is maintained. This example also used the same parameter identifier and localparam identifier in both module top4 and config cfg2. There is no conflict in the configuration since the localparam in config cfg2 is directly accessed in the configuration. When config cfg2 needs to use parameter S in module top, parameter S has to be referenced via the design name in the configuration.

A parameter override with empty parentheses will set the parameter back to its default as defined in its module.

```

module top5 (...);
  parameter WIDTH = 64, DEPTH = 1024, ID = "A1";
  adder a1 #(.ID(ID), .W(WIDTH), .D(DEPTH)) (...);
endmodule

```

Example 5

Using the code above, the \$display in adder will print the following:

```

ID = A1, W=64, D = 1024

config cfg3;
  design rtlLib.top5;
  instance top5.a1 use #(.W()); // set only parameter W back to its default
endconfig

```

Example 6

When the above configuration cfg3 configures module top5.a1, the \$display in adder will print the following:

```

ID = A1, W=8, D = 1024

```

Only parameter w is configured to use its default value.

All the parameters can be reset to their default values, meaning their initial values prior to any parameter overrides. This is shown in the following configuration, which uses the module top from Example 2.

```

config cfg4;
  design rtlLib.top;
  instance top.a1 use #(); // set all parameters in instance a1
  // back to their defaults
endconfig

```

Example 7

This configuration of top.a1 will print the following:

```

ID = id, W=8, D = 512

```

When both a configuration and a defparam statement are modifying the same parameter at the same hierarchal level, the configuration shall take precedence. The following code adds a level of hierarchy, which includes defparam statements:

```

module test;
  ...
  top8 t(...);

```



```
    defparam t.WIDTH = 64;
    defparam t.a1.W = 16;
    ...
endmodule

module top8 (...);
    parameter WIDTH = 32;
    adder a1 #(.ID("a1")) (...);
    adder a2 #(.ID("a2"), .W(WIDTH)) (...);
endmodule

module adder #(parameter ID = "id",
                W = 8,
                D = 512)
    (...);
    ...
    $display("ID = %s, W = %d, D = %d", ID, W, D);
    ...
endmodule

config cfg6;
    design rtlLib.test;
    instance test.t use #(.WIDTH(48));
endconfig
```

Example 8

With `cfg6` configuring module `top8.a1`, the `$display` in `adder` will print the following:

```
ID = a1, W=16, D = 512
ID = a2, W=48, D = 512
```

33.5 Using libraries and configs

This subclause describes potential use models for referencing configs on the command line. It is included for clarification purposes.

The traditional SystemVerilog simulation use model takes a file-based approach, where the source descriptions for all cells in the design are specified on the command line for each invocation of the tool. With the advent of compiled-code simulators, the configuration mechanism shall also support a use model that allows for the source files to be precompiled and then for the precompiled design objects to be referenced on the command line. This subclause explains how configurations can be used in both of these scenarios.

33.5.1 Precompiling in a single-pass use model

The single-pass use model is the traditional use model with which most users are familiar. In this use model, all of the source description files shall be provided to the simulator via the command line, and only these source descriptions can be used to bind cell instances in the current design. A precompiling strategy in this scenario actually parses every cell description provided on the command line and maps it into the library without regard to whether the cell actually is used in the design. The tool can optionally check to see whether the cell already exists in the library and, if it is up-to-date (i.e., the source description has not changed since the last time the cell was compiled), can skip recompiling the cell. After all cells on the command line have been compiled, then the tool can locate the top-level cell (discussed in [23.3.1](#)) and proceed down the hierarchy, binding each instance as it is encountered in the hierarchy.

NOTE—With this use model, it is not necessary for library objects to persist from one tool invocation to another (although for performance considerations it is recommended they do).

33.5.2 Elaboration-time compiling in a single-pass use model

An alternate strategy that can be used with a single-pass tool is to parse the source files only to find the top-level module(s), without actually compiling anything into the library during this scanning process. Once the top-level module(s) has been found, then it can be compiled into the library, and the tool can proceed down the hierarchy, only compiling the source descriptions necessary to bind the design successfully. Based on the binding rules in place, only the source files that match the current library specification need to be parsed to find the current cell's source description to compile. As with the precompiled single-pass use model, it is not necessary for library cells to persist from one invocation to another using this strategy.

33.5.3 Precompiling using a separate compilation tool

When using a separate compilation tool, it is essential that library cells persist, and the compiled forms shall, therefore, exist somewhere in the file system. The exact format and location for holding these compiled forms shall be vendor- or tool-specific. Using this separate compiler strategy, the source descriptions shall be parsed and compiled into the library using one or more invocations of the compiler tool. The only restriction is that all cells in a design shall be precompiled prior to binding the design (typically via an invocation of a separate tool). Using this strategy, the tool that actually does the binding only needs to be told the top-level module(s) of the design to be bound, and then it shall use the precompiled form of the cell description(s) from the library to determine the subinstances and descend hierarchically down the design, binding each cell as it is located.

33.5.4 Command line considerations

In each of the three preceding strategies, either the binding rules can be specified via a config, or the default rules (from the library map file) can be used. In the single-pass use models, the config can be specified by including its source description file on the command line. In the case where the config includes a design statement, then the specified cell shall be the top-level module, regardless of the presence of any uninstantiated cells in the rest of the source files. When using a separate compilation tool, the tool that actually does the binding only needs to be given the *lib.cell* specification for the top-level cell(s) and/or the config to be used. In this strategy, the config itself shall also be precompiled.

33.6 Configuration examples

Consider the following set of source descriptions:

```

file top.v          file adder.v          file adder.vg          file lib.map
module top(...);  module adder(...);   module adder(...);   library rtlLib top.v;
...                ... // rtl                ... // gate-level    library aLib adder.*;
adder a1(...);    m f1(...);          m f1(...);          library gateLib
adder a2(...);    m f2(...);          m f2(...);          adder.vg;
endmodule        endmodule          endmodule
module m(...);   module m(...);     module m(...);
... // rtl        ... // rtl          ... // gate-level
endmodule        endmodule          endmodule

```

All of the examples in this subclause shall assume the *top.v*, *adder.v* and *adder.vg* files get compiled with the given *lib.map* file. This yields the following library structure:

```

rtlLib.top    // from top.v
rtlLib.m      // from top.v
aLib.adder    // from adder.v

```

```
aLib.m          // rtl from adder.v  
gateLib.adder  // from adder.vg  
gateLib.m      // from adder.vg
```

33.6.1 Default configuration from library map file

With no configuration, the libraries are searched according to the library declaration order in the library map file. In other words, all instances of module `adder` shall use `aLib.adder` (because `aLib` is the first library specified that contains a cell named `adder`), and all instances of module `m` shall use `rtlLib.m` (because `rtlLib` is the first library that contains `m`).

33.6.2 Using default clause

To always use the `m` definition from file `adder.v`, use the following simple configuration:

```
config cfg1;  
  design rtlLib.top;  
  default liblist aLib rtlLib;  
endconfig
```

The `default liblist` statement overrides the library search order in the `lib.map` file; therefore, `aLib` is always searched before `rtlLib`. Because the `gateLib` library is not included in the `liblist`, the gate-level descriptions of `adder` and `m` shall not be used.

To use the gate-level representations of `adder` and `m`, add to the config as follows:

```
config cfg2;  
  design rtlLib.top;  
  default liblist gateLib aLib rtlLib;  
endconfig
```

This shall cause the gate representation always to be taken before the `rtl` representation, using the module definitions for `adder` and `m` from `adder.vg`. The `rtl` view of `top` shall be taken because there is no gate representation available.

33.6.3 Using cell clause

To modify the config to use the `rtl` view of `adder` and the gate-level representation of `m` from `gateLib`, use the following:

```
config cfg3;  
  design rtlLib.top;  
  default liblist aLib rtlLib;  
  cell m use gateLib.m ;  
endconfig
```

The cell clause selects all cells named `m` and explicitly binds them to the gate representation in `gateLib`.

33.6.4 Using instance clause

To modify the config so the `top.a1 adder` (and its descendants) use the gate representation and the `top.a2 adder` (and its descendants), use the `rtl` representation from `aLib`:

```
config cfg4  
  design rtlLib.top;  
  default liblist gateLib rtlLib;
```

```

    instance top.a2 liblist aLib;
endconfig

```

Because the `liblist` is inherited, all of the descendants of `top.a2` inherit its `liblist` from the instance selection clause.

33.6.5 Using hierarchical config

Now suppose all this work has only been on the adder module by itself and a config that uses the `rtlLib.m` cell for `f1`, and the `gateLib.m` cell for `f2` has already been developed. Then, use the following:

```

config cfg5;
  design aLib.adder;
  default liblist gateLib aLib;
  instance adder.f1 liblist rtlLib;
endconfig

```

To use this configuration `cfg5` for the `top.a2` instance of `adder` and take the full default `aLib` adder for the `top.a1` instance, use the following config:

```

config cfg6;
  design rtlLib.top;
  default liblist aLib rtlLib;
  instance top.a2 use work.cfg5:config;
endconfig

```

The binding clause specifies the `work.cfg5:config` configuration is to be used to resolve the bindings of instance `top.a2` and its descendants. It is the design statement in config `cfg5` that defines the exact binding for the `top.a2` instance itself. The rest of `cfg5` defines the rules to bind the descendants of `top.a2`. Notice the instance clause in `cfg5` is relative to its own top-level module, `adder`.

33.7 Displaying library binding information

It shall be possible to display the actual library binding information for module instances during simulation. The format specifier `%l` or `%L` shall print out the `library.cell` binding information for the module instance containing the display (or other textual output) command. This is similar to the `%m` format specifier, which prints out the hierarchical path name of the module containing it.

It shall also be able to use VPI to display the binding information. The following VPI properties shall exist for objects of type `vpiModule`:

- `vpiLibrary`—the library name into which the module was compiled
- `vpiCell`—the name of the cell bound to the module instance
- `vpiConfig`—the `library.cell` name of the config controlling the binding of the module instance

These properties shall be of `string` type, similar to the `vpiName` and `vpiFullName` properties.

33.8 Library mapping examples

In the absence of a configuration, it is possible to perform basic control of the library searching order when binding a design.

When a config is used, the config overrides the rules specified in this subclause.

33.8.1 Using the command line to control library searching

In the absence of a configuration, it shall be necessary for all compliant tools to provide a mechanism of specifying a library search order on the command line that overrides the default order from the library map file. This mechanism shall include specification of library names only, with the definitions of these libraries to be taken from the library map file.

NOTE—It is recommended all compliant tools use “-L <library_name>” to specify this search order.

33.8.2 File path specification examples

For example, given the following set of files:

```
/proj/lib1/rtl/a.v  
/proj/lib2/gates/a.v  
/proj/lib1/rtl/b.v  
/proj/lib2/gates/b.v
```

From the /proj library, the following absolute file_path_specs are resolved as shown:

```
/proj/lib*/*/a.v = /proj/lib1/rtl/a.v, /proj/lib2/gates/a.v  
../a.v          = /proj/lib1/rtl/a.v, /proj/lib2/gates/a.v  
/proj/.../b.v   = /proj/lib1/rtl/b.v, /proj/lib2/gates/b.v  
../rtl/*v       = /proj/lib1/rtl/a.v, /proj/lib1/rtl/b.v
```

From the /proj/lib1 directory, the following relative file_path_specs are resolved as shown:

```
../lib2/gates/*v = /proj/lib2/gates/a.v, /proj/lib2/gates/b.v  
./rtl/?v         = /proj/lib1/rtl/a.v, /proj/lib1/rtl/b.v  
./rtl/           = /proj/lib1/rtl/a.v, /proj/lib1/rtl/b.v
```

33.8.3 Resolving multiple path specifications

For example:

```
library lib1 "/proj/lib/foo*.v";  
library lib2 "/proj/lib/foo.v";  
library lib3 "../lib/";  
library lib4 "/proj/lib/*ver.v";
```

When evaluated from the directory /proj/tb directory, the following source files shall map into the specified library:

```
../lib/foobar.v // Maps to library lib1. Potentially matches lib1 and  
// lib3. Because lib1 includes a filename and lib3 only  
// specifies a directory, lib1 takes precedence  
// (see 33.3.1.1 b)  
  
/proj/lib/foo.v // Maps to library lib2. Takes precedence over lib1 and  
// lib3 path specifications (see 33.3.1.1 a)  
  
/proj/lib/bar.v // Maps to library lib3. (see 33.3.1.1 c)  
  
/proj/lib/barver.v // Maps to library lib4. Takes precedence over lib3 path  
// specification (32.3.1.1b)  
  
/proj/lib/foover.v // ERROR, matches lib1 and lib4 (see 33.3.1.1)
```

```
/test/tb/tb.v // Maps to library work. Does not match any library  
// specification (see 33.3.1)
```

34. Protected envelopes

34.1 General

This clause describes the following:

- Processing protected envelopes
- Protect pragma directives
- Protect pragma keywords

34.2 Overview

Protected envelopes specify a region of text that shall be transformed prior to analysis by the source language processor. These regions of text are structured to provide the source language processor with the specification of the cryptographic algorithm, key, envelope attributes, and textual design data.

All information that identifies a protected envelope is introduced by the **protect** pragma (see [22.11](#)). This pragma is reserved by this standard for the description of protected envelopes and is the prefix for specifying the regions and processing specifications for each protected envelope. Additional information is associated with the pragma by appending pragma expressions. The pragma expressions of the **protect** pragma are evaluated in sequence from left to right. Interpretation of protected envelopes shall not be altered based on whether the sequence of pragma expressions occurs in a single **protect** pragma directive or in a sequence of **protect** pragma directives. In this clause, unless otherwise specified, pragma directives, pragma keywords, and pragma expressions shall refer to occurrences of **protect** pragma directives and their associated pragma keywords and pragma expressions.

Envelopes may be defined for either of two modes of processing. *Encryption envelopes* specify the pragma expressions for encrypting source text regions. An encryption envelope begins in the source text when a **begin** pragma expression is encountered. The end of the encryption envelope occurs at the point where an **end** pragma expression is encountered. The **end** pragma expression is said to close the envelope and shall be associated with the most recent **begin** pragma expression.

Decryption envelopes specify the pragma expressions for decrypting encrypted text regions. A decryption envelope begins in the source text when a **begin_protected** pragma expression is encountered. The end of the decryption envelope occurs at the point where an **end_protected** pragma expression is encountered. The **end_protected** pragma expression is said to close the envelope and shall be associated with the most recent **begin_protected** that has not already been closed. Decryption envelopes may contain other envelopes within their enclosed data block. The number of nested decryption envelopes that can be processed is implementation-specific; however, that number shall be no less than 8. Code that is contained within a decryption envelope is said to be protected.

Pragma expressions that precede **begin** or **begin_protected** are designated as *envelope keywords*. Pragma expressions that follow the **begin/begin_protected** keywords and precede the associated **end/end_protected** keywords are designated as *content keywords*. Content keywords are pragma expressions that are within the region of text that is processed during encryption or decryption of a protected envelope.

34.3 Processing protected envelopes

Two modes of processing are defined for protected envelopes. *Envelope encryption* is the process of recognizing encryption envelopes in the source text and transforming them into decryption envelopes. *Envelope decryption* is the process of recognizing decryption envelopes in the input text and transforming them into the corresponding cleartext for the compilation step that follows.

Tools that process SystemVerilog source code shall perform envelope decryption for all decryption envelopes contained in the source text, where the proper key is supplied by the user. Tools that perform envelope encryption shall only be required to process the **protect** pragma directives and shall apply no other interpretation to text that is not part of a **protect** pragma directive.

34.3.1 Encryption

SystemVerilog tools that provide encryption services shall transform source text containing encryption envelopes by replacing each encryption envelope with a decryption envelope formed by encrypting the source text of the encryption envelope according to the specified pragma expressions.

Source text that is not contained in an encryption envelope shall not be modified by the encrypting language processor, unless otherwise specified.

Decryption envelopes are formed from encryption envelopes by transforming the specified encryption envelope pragma expressions into decryption envelope pragma expressions and decryption content pragma expressions. The body of the encryption envelope is encrypted using the specified key, referred to as the *exchange key*, and is recorded in the decryption envelope as a **data_block**.

Encryption algorithms that use the same key to encrypt cleartext and decrypt the corresponding ciphertext are said to be *symmetric*. Algorithms that require different keys to encrypt and decrypt are said to be *asymmetric*. This description may be applied to both the algorithm and the key.

Tools that provide encryption services may support *session keys* to limit exposure to the exchange key that is specified by the IP author using the encryption envelope pragma expressions. A session key is created in an unspecified manner to encrypt the data from the encryption envelope. A copy of the session key is encrypted using the exchange key and is recorded in a **key_block** in the decryption envelope. Next, the body of the encryption envelope is encrypted using the session key and is recorded in the decryption envelope as a **data_block**.

The following example shows the use of the **protect** pragma to specify encryption of design data. The encryption method is a simple substitution cipher where each alphabetic character is replaced with the 13th character in alphabetic sequence, commonly referred to as “rot13”. Nonalphabetic characters are not substituted. The following design data contain an encryption envelope that specifies the desired protection.

```
module secret (a, b);
  input a;
  output b;

  `pragma protect encoding=(enctype="raw")
  `pragma protect data_method="x-caesar", data_keyname="rot13", begin
  `pragma protect
runtime_license=(library="lic.so", feature="runSecret", entry="chk", match=42)
  logic b;

  initial
  begin
    b = 0;
  end

  always
  begin
    #5 b = a;
  end
  `pragma protect end
```

```
endmodule // secret
```

After encryption processing, the following design data are produced. The decryption envelope is written with a “raw” encoding to make the substitution encryption directly visible.

NOTE 1—The encoded line beginning ``centzn` is actually one long line, but it wraps over to the following line on the printed page.

```
module secret (a, b);
  input a;
  output b;

  `pragma protect encoding=(enctype="raw")
  `pragma protect data_method="x-caesar", data_keyname="rot13",
  begin_protected
  `pragma protect data_block encoding=(enctype="raw", bytes=190)
  `centzn cebgrpg ehagvzr_yvprafr=(yvoenel="yvp.fb", srngher="ehaFrperg",
  ragel="pux", zngpu=42)
  ert o;

  vavgvny
  ortva
  o = 0;
  raq

  nyjnlf
  ortva
  #5 o = n;
  raq
  `pragma protect end_protected
  `pragma reset protect

endmodule // secret
```

NOTE 2—Products that include cryptographic algorithms may be subject to government regulations in many jurisdictions. Users of this standard are advised to seek the advice of competent counsel to determine their obligations under those regulations.

34.3.2 Decryption

SystemVerilog tools that support decrypting compilation shall transform source text containing decryption envelopes by replacing each decryption envelope with the decrypted source text from the `data_block`, according to the specified pragma expressions. The substituted text may contain usages of text macros, which shall be substituted after replacement of the decryption envelope. The substituted text may also contain decryption envelopes, which shall be decrypted and substituted after replacement of their enclosing decryption envelope.

34.4 Protect pragma directives

Protected envelopes are lexical regions delimited by `protect` pragma directives. The effect of a particular `protect` pragma directive is specified by its pragma expressions. This standard defines the pragma keyword names listed in [Table 34-1](#) for use with the `protect` pragma. These pragma keywords are defined in [34.5](#) with a specification of how each participates in the encryption and decryption processing modes.

Table 34-1—protect pragma keywords

Pragma keyword	Description
begin	Opens a new encryption envelope
end	Closes an encryption envelope
begin_protected	Opens a new decryption envelope
end_protected	Closes a decryption envelope
author	Identifies the author of an envelope
author_info	Specifies additional author information
encrypt_agent	Identifies the encryption service
encrypt_agent_info	Specifies additional encryption service information
encoding	Specifies the coding scheme for encrypted data
data_keyowner	Identifies the owner of the data encryption key
data_method	Identifies the data encryption algorithm
data_keyname	Specifies the name of the data encryption key
data_public_key	Specifies the public key for data encryption
data_decrypt_key	Specifies the data session key
data_block	Begins an encoded block of encrypted data
digest_keyowner	Identifies the owner of the digest encryption key
digest_key_method	Identifies the digest encryption algorithm
digest_keyname	Specifies the name of the digest encryption key
digest_public_key	Specifies the public key for digest encryption
digest_decrypt_key	Specifies the digest session key
digest_method	Specifies the digest computation algorithm
digest_block	Specifies a message digest for data integrity
key_keyowner	Identifies the owner of the key encryption key
key_method	Specifies the key encryption algorithm
key_keyname	Specifies the name of the key encryption key
key_public_key	Specifies the public key for key encryption
key_block	Begins an encoded block of key data
decrypt_license	Specifies licensing constraints on decryption
runtime_license	Specifies licensing constraints on simulation
comment	Uninterpreted documentation string
reset	Resets pragma keyword values to default
viewport	Modifies scope of access into decryption envelope

The scope of **protect** pragma directives is completely lexical and not associated with any declarative region or declaration in the source text itself. This lexical scope may cross file boundaries and included files.

In protected envelopes where a specific pragma keyword is absent, the SystemVerilog tool shall use the default value. SystemVerilog tools that perform encryption should explicitly output all relevant pragma keywords for each envelope in order to avoid unintended interpretations during decryption. Further robustness can be achieved by appending a **reset** pragma keyword after each envelope.

34.5 Protect pragma keywords

34.5.1 begin

34.5.1.1 Syntax

```
begin
```

34.5.1.2 Description

ENCRYPTION INPUT: The **begin** pragma expression is used in the input text to indicate to an encrypting tool the point at which encryption shall begin.

Nesting of pragma **begin-end** blocks shall be an error. There may be **begin_protected-end_protected** blocks containing previously encrypted content inside such a block. They are simply treated as a byte stream and encrypted as if they were text.

ENCRYPTION OUTPUT: The **begin** pragma expression is replaced in the encryption output stream by the **begin_protected** pragma expression. Following **begin_protected**, all pragma expressions required as encryption output shall be generated prior to the **end_protected** pragma expression. Protected envelopes should be completely self-contained to avoid any undesired interaction when multiple encrypted models exist in the decryption input stream. The **data_block** and **key_block** pragma expressions introduce the encrypted data or keys and will always be found within a **begin_protected-end_protected** envelope. All text, including comments and other **protect** pragmas, occurring between the **begin** pragma expression and the corresponding **end** pragma expression shall, unless otherwise specified, be encrypted and placed in the encryption output stream using the **data_block** pragma expression. An unspecified length of arbitrary comment text may be added by the encrypting tool to the beginning and end of the input text in order to prevent known text attacks on the encrypted content of the **data_block**.

DECRYPTION INPUT: none

34.5.2 end

34.5.2.1 Syntax

```
end
```

34.5.2.2 Description

ENCRYPTION INPUT: The **end** pragma expression is used in the input cleartext to indicate the end of the region that shall be encrypted.

ENCRYPTION OUTPUT: The **end** pragma expression is replaced in the encryption output stream by the **end_protected** pragma expression.

DECRYPTION INPUT: none

34.5.3 **begin_protected**

34.5.3.1 Syntax

```
begin_protected
```

34.5.3.2 Description

ENCRYPTION INPUT: When a **begin_protected-end_protected** block is found in an input file during encryption, its contents are treated as input cleartext. This allows a previously encrypted model to be reencrypted as a portion of a larger model. Any other **protect** pragmas inside the **begin_protected-end_protected** block shall not be interpreted and shall not override pragmas in effect. Nested encryption shall not corrupt pragma values in the current encryption in process.

ENCRYPTION OUTPUT: The **begin_protected** pragma expression, and the entire content of the protected envelope up to the corresponding **end_protect** pragma expression, shall be encrypted into the current **data_block** as specified by the current method and keys.

DECRYPTION INPUT: The **begin_protected** pragma expression begins a previously encrypted region. A decrypting tool shall accumulate all the pragma expressions in the block for use in decryption of the block.

34.5.4 **end_protected**

34.5.4.1 Syntax

```
end_protected
```

34.5.4.2 Description

ENCRYPTION INPUT: This pragma expression indicates the end of a previous **begin_protected** block. This indicates that the block is complete, and subsequent pragma expression values will be accumulated for the next envelope.

ENCRYPTION OUTPUT: The **end_protected** pragma expression following the corresponding **begin_protected** pragma expression shall be encrypted into the current **data_block** as specified by the current method and keys.

DECRYPTION INPUT: The **end_protected** pragma expression indicates the end of a set of pragmas that are sufficient to decrypt the current block.

34.5.5 **author**

34.5.5.1 Syntax

```
author = <string>
```

34.5.5.2 Description

ENCRYPTION INPUT: The **author** pragma expression specifies a string that identifies the name of the IP author. It is distinct from the comment pragma expression so that this information can be recognized without need for parsing of a comment string value.

ENCRYPTION OUTPUT: If present in the encryption envelope, the **author** pragma expression shall be placed in a pragma directive enclosed within the protected envelope, but shall not be encrypted into the **data_block**. Otherwise, it is copied without change into the output stream.

DECRYPTION INPUT: none

34.5.6 **author_info**

34.5.6.1 Syntax

```
author_info = <string>
```

34.5.6.2 Description

ENCRYPTION INPUT: The **author_info** pragma expression specifies a string that contains additional information provided by the IP author. It is distinct from the comment pragma expression so that this information can be recognized without need for parsing of a comment string value.

ENCRYPTION OUTPUT: If present in the encryption envelope, the **author_info** pragma expression shall be placed in a pragma directive enclosed within the protected envelope, but shall not be encrypted into the **data_block**. Otherwise, it is copied without change into the output stream.

DECRYPTION INPUT: none

34.5.7 **encrypt_agent**

34.5.7.1 Syntax

```
encrypt_agent = <string>
```

34.5.7.2 Description

ENCRYPTION INPUT: none

ENCRYPTION OUTPUT: The **encrypt_agent** pragma expression specifies a string that identifies the name of the encrypting tool. The encrypting tool shall generate this pragma expression and place it in a pragma directive enclosed within the protected envelope, but shall not encrypt it into the **data_block**.

DECRYPTION INPUT: none

34.5.8 **encrypt_agent_info**

34.5.8.1 Syntax

```
encrypt_agent_info = <string>
```

34.5.8.2 Description

ENCRYPTION INPUT: none

ENCRYPTION OUTPUT: The **encrypt_agent_info** pragma expression specifies a string that contains additional information provided by the encrypting tool. If provided, the **encrypt_agent_info** pragma expression shall be placed within a pragma directive enclosed within the protected envelope, but shall not be encrypted into the **data_block**.

DECRYPTION INPUT: none

34.5.9 encoding

34.5.9.1 Syntax

encoding = (**enctype** = <string> , **line_length** = <number> , **bytes** = <number>)

34.5.9.2 Description

ENCRYPTION INPUT: The **encoding** pragma expression specifies how the **data_block**, **digest_block**, and **key_block** content shall be encoded. This encoding allows all binary data produced in the encryption process to be treated as text. If an **encoding** pragma expression is present in the input stream, it specifies how the output shall be encoded.

The **encoding** pragma expression shall be a pragma_expression value containing encoding subkeywords separated by white space. The following subkeywords are defined for the value of the **encoding** pragma expression:

enctype=<string> The method for calculating the encoding. This standard specifies the identifiers in [Table 34-2](#) as string values for the enctype subkeyword. These identifiers are associated with their respective encoding algorithms. The required methods are standard in every implementation. Optional identifiers are implementation-specific, but are required to use these identifiers for the corresponding encoding algorithm. Additional identifier values and their corresponding encoding algorithms are implementation-defined.

Table 34-2—Encoding algorithm identifiers

enctype	Required /optional	Encoding algorithm
uuencode	Required	IEEE Std 1003.1 (uuencode historical algorithm)
base64	Required	IETF RFC 2045 [also IEEE Std 1003.1 (uuencode -m)]
quoted-printable	Optional	IETF RFC 2045
raw	Optional	Identity transformation; No encoding shall be performed, and the data may contain nonprintable characters.

line_length=<number>The maximum number of characters (after any encoding) in a single line of the **data_block**. Insertion of line breaks in the **data_block** after encryption and encoding allows the generated text files to be usable by commonly available text tools.

bytes=<number> The number of bytes in the original block of data before any encoding or the addition of line breaks. This encoding keyword shall be ignored in the encryption input.

ENCRYPTION OUTPUT: The **encoding** directive shall be output in each **begin_protected-end_protected** block to explicitly specify the encoding used by the **encrypt_agent**. A tool may choose to encode the data even if no **encoding** pragma expression was found in the input stream and shall output the corresponding **encoding** pragma expression. The tool shall generate an encoding descriptor that specifies in the bytes keyword the number of bytes in the original block of data.

The `data_block`, `data_public_key`, `data_decrypt_key`, `digest_block`, `key_block`, and `key_public_key` are all encoded using this encoding. If separate encoding is desired for each of these fields, then multiple `encoding` pragma expressions can be given in the input stream prior to each of the above pragma expressions. The `bytes` value is added by the encrypting tool for each block that it encrypts.

DECRYPTION INPUT: During decryption, the `encoding` directive is used to find the encoding algorithm used and the size of actual data.

34.5.10 `data_keyowner`

34.5.10.1 Syntax

```
data_keyowner = <string>
```

34.5.10.2 Description

ENCRYPTION INPUT: The `data_keyowner` specifies the legal entity or tool that provided the keys used for encryption and decryption of the data. This pragma keyword permits use of a third-party key, distinct from one associated with either `author` or `encrypt_agent`. The `data_keyowner` value is used by the encrypting tool to select the key used to encrypt the `data_block`. The values for `data_keyname`, `data_decrypt_key`, and `data_public_key` shall be unique for the specified `data_keyowner`.

ENCRYPTION OUTPUT: The `data_keyowner` shall be unchanged in the output file, except where a digital signature is used, in which case it is encrypted with the `key_method` and placed in a `key_block`.

DECRYPTION INPUT: During decryption, the `data_keyowner` is combined with the `data_keyname` or `data_public_key` to determine the appropriate secret/private key to use during decryption of the `data_block`.

34.5.11 `data_method`

34.5.11.1 Syntax

```
data_method = <string>
```

34.5.11.2 Description

ENCRYPTION INPUT: The `data_method` pragma expression specifies the encryption algorithm that shall be used to encrypt subsequent `begin-end` blocks. The encryption method is an identifier that is commonly associated with a specific encryption algorithm. If the specified encryption algorithm uses a cipher-block chaining (CBC) technique that requires an Initialization Vector (IV), it is recommended that the Initialization Vector be randomly generated for each use of the cipher.

This standard specifies the identifiers in [Table 34-3](#) as string values for the `data_method` pragma expression. These identifiers are associated with their respective encryption types. The required methods are standard in every implementation. Optional identifiers are implementation-specific, but are required to use these identifiers for the corresponding cipher. Additional identifier values and their corresponding ciphers are implementation-defined.

Table 34-3—Encryption algorithm identifiers

Identifier	Required /optional	Encryption algorithm
des-cbc	Required	Data Encryption Standard (DES) in CBC mode, see FIPS 46-3. ^a
3des-cbc	Optional	Triple DES in CBC mode, see FIPS 46-3; ANSI X9.52-1998.
aes128-cbc	Optional	Advanced Encryption Standard (AES) with 128-bit key, see FIPS 197.
aes256-cbc	Optional	AES in CBC mode, with 256-bit key.
aes192-cbc	Optional	AES with 192-bit key.
blowfish-cbc	Optional	Blowfish in CBC mode, see Schneier (Blowfish).
twofish256-cbc	Optional	Twofish in CBC mode, with 256-bit key, see Schneier (<i>Twofish</i>).
twofish192-cbc	Optional	Twofish with 192-bit key.
twofish128-cbc	Optional	Twofish with 128-bit key.
serpent256-cbc	Optional	Serpent in CBC mode, with 256-bit key, see Anderson, et al.
serpent192-cbc	Optional	Serpent with 192-bit key.
serpent128-cbc	Optional	Serpent with 128-bit key.
cast128-cbc	Optional	CAST-128 in CBC mode, see IETF RFC 2144.
rsa	Optional	RSA, see IETF RFC 2437.
elgamal	Optional	ElGamal, see ElGamal.
pgp-rsa	Optional	OpenPGP RSA key, see IETF RFC 2440.

^aFor information on references, see [Clause 2](#).

ENCRYPTION OUTPUT: The **data_method** shall be unchanged in the output file, except where a digital signature is used, in which case it is encrypted with the **key_method** and placed in a **key_block**.

DECRYPTION INPUT: The **data_method** specifies the algorithm that should be used to decrypt the **data_block**.

34.5.12 data_keyname

34.5.12.1 Syntax

data_keyname = <string>

34.5.12.2 Description

ENCRYPTION INPUT: The **data_keyname** pragma expression specifies the name of the key, or key pair for an asymmetric encryption algorithm, that should be used to decrypt the **data_block**. It shall be an error to specify a **data_keyname** that is not a member of the list of keys known for the given **data_keyowner**.

ENCRYPTION OUTPUT: When a **data_keyname** is provided in the input, it indicates the key that should be used for encrypting the data. The encrypting tool shall combine this pragma expression with the **data_keyname** and determine the key to use. The **data_keyname** itself shall be output as cleartext in the output file except where a digital envelope is used. For a digital envelope mechanism, the **data_keyname** is encrypted using **key_method** and **key_keyname/key_public_key** and encoded in the **key_block**.

DECRYPTION INPUT: The **data_keyname** value is combined with the **data_keyowner** to select a single key that shall be used to decrypt the **data_block** from the protected envelope.

34.5.13 data_public_key

34.5.13.1 Syntax

data_public_key

34.5.13.2 Description

ENCRYPTION INPUT: The **data_public_key** pragma expression specifies that the next line of the file contains the encoded value of the public key to be used to encrypt the data. The encoding is specified by the **encoding** pragma expression that is currently in effect. If both **data_public_key** and **data_keyname** are present, then they shall refer to the same key.

ENCRYPTION OUTPUT: The **data_public_key** pragma expression shall be output in each protected block for which it is used, followed by the encoded value. The **data_method** and **data_public_key** can be combined to fully specify the required encryption.

DECRYPTION INPUT: The **data_keyowner** and **data_method** can be combined with the **data_public_key** to determine whether the decrypting tool knows the corresponding private key to decrypt a given **data_block**. If the decrypting tool can compute the required key, the model can be decrypted (if licensing allows it).

34.5.14 data_decrypt_key

34.5.14.1 Syntax

data_decrypt_key

34.5.14.2 Description

ENCRYPTION INPUT: The **data_decrypt_key** indicates that the next line contains the encoded value of the key that will decrypt the **data_block**. This pragma expression should only be used when digital signatures are used. An IP author can generate a key and use it to encrypt the cleartext. This encrypted text is then stored in the output file as the **data_block**. Then the **data_method** and **data_decrypt_key** are encrypted using the **key_method** and stored in the output file as the contents of the **key_block**. The **data_block** itself is not reencrypted; only the information about the data key is.

ENCRYPTION OUTPUT: The **data_decrypt_key** is output as part of the encrypted content of the **key_block**. The value is encoded as specified by the **encoding** pragma expression.

DECRYPTION INPUT: Upon determining that a digital signature was in use for a given protected region, the decrypting tool shall decrypt the **key_block** to find the **data_decrypt_key** and **data_method** that in turn can be used to decrypt the **data_block**.

34.5.15 data_block

34.5.15.1 Syntax

```
data_block
```

34.5.15.2 Description

ENCRYPTION INPUT: It shall be an error if a **data_block** is found in an input file unless it is contained within a previously generated **begin_protected-end_protected** block, in which case it is ignored.

ENCRYPTION OUTPUT: The **data_block** pragma expression indicates that a data block begins on the next line in the file. The encrypting tool shall take each **begin-end** block, encrypt the contents as specified by the **data_block** pragma expression, and then encode the block as specified by the **encoding** pragma expression. The resultant text shall be output. If the **data_method** specifies a cipher-block chaining encryption algorithm that requires an Initialization Vector (IV), then the IV cipher-block shall be prepended to the encrypted data before encoding is performed.

DECRYPTION INPUT: The **data_block** is first read in the encoded form. The encoding shall be reversed, and then the block shall be internally decrypted. If the **data_method** specifies a cipher-block chaining encryption algorithm that requires an Initialization Vector (IV), then the first cipher-block of the decoded **data_block** shall be removed for use as the IV. The remainder of the **data_block** shall be internally decrypted.

34.5.16 digest_keyowner

34.5.16.1 Syntax

```
digest_keyowner = <string>
```

34.5.16.2 Description

ENCRYPTION INPUT: The **digest_keyowner** specifies the legal entity or tool that provided the keys used for encryption and decryption of the data. This pragma keyword permits use of a third-party key, distinct from one associated with either **author** or **encrypt_agent**. The **digest_keyowner** value is used by the encrypting tool to select the key used to encrypt the **digest_block**. The values for **digest_keyname**, **digest_decrypt_key**, and **digest_public_key** shall be unique for the specified **digest_keyowner**. If no **digest_keyowner** is specified in the input, then the default value of **digest_keyowner** shall be the current value of **data_keyowner**.

ENCRYPTION OUTPUT: The **digest_keyowner** shall be unchanged in the output file, except where a digital signature is used, in which case it is encrypted with the **digest_key_method** and placed in a **digest_key_block**.

DECRYPTION INPUT: During decryption, the **digest_keyowner** is combined with the **digest_keyname** or **digest_public_key** to determine the appropriate secret/private key to use during decryption of the **digest_block**.

34.5.17 digest_key_method

34.5.17.1 Syntax

```
digest_key_method = <string>
```

34.5.17.2 Description

ENCRYPTION INPUT: The `digest_key_method` pragma expression indicates the encryption algorithm that shall be used to encrypt subsequent `digest_block` contents. The values specified for `digest_key_method` to identify encryption algorithms are the same as those specified for `data_method`. If no `digest_key_method` is specified in the input, then the default value of `digest_key_method` shall be the current value of `data_method`.

ENCRYPTION OUTPUT: The `digest_key_method` shall be unchanged in the output file, except where a digital signature is used, in which case it is encrypted with the `key_method` algorithm and uses the key found in the `key_block`.

DECRYPTION INPUT: The `digest_key_method` indicates the algorithm that shall be used to decrypt the `digest_block`.

34.5.18 digest_keyname

34.5.18.1 Syntax

```
digest_keyname = <string>
```

34.5.18.2 Description

ENCRYPTION INPUT: The `digest_keyname` pragma expression provides the name of the key, or key pair for an asymmetric encryption algorithm, that shall be used to decrypt the `digest_block`. It shall be an error to specify a `digest_keyname` that is not a member of the list of keys known for the given `digest_keyowner`. If no `digest_keyname` is specified in the input, then the default value of `digest_keyname` shall be the current value of `data_keyname`.

ENCRYPTION OUTPUT: When a `digest_keyname` is provided in the input, it indicates the key that shall be used for encrypting the data. The encrypting tool shall combine this pragma expression with the `digest_keyowner` and determine the key to use. The `digest_keyname` itself shall be output as cleartext in the output file except where a digital envelope is used. For a digital envelope mechanism, the `digest_keyname` is encrypted using `key_method` and `key_keyname/key_public_key` and encoded in the `key_block`.

DECRYPTION INPUT: The `digest_keyname` value is combined with the `digest_keyowner` to select a single key that shall be used to decrypt the `digest_block` from the protected envelope.

34.5.19 digest_public_key

34.5.19.1 Syntax

```
digest_public_key
```

34.5.19.2 Description

ENCRYPTION INPUT: The `digest_public_key` pragma expression indicates that the next line of the file contains the encoded value of the public key used to encrypt the digest. The encoding is specified by the `encoding` pragma expression that is currently in effect. If both `digest_public_key` and `digest_keyname` are present, then they shall refer to the same key. If no `digest_public_key` is specified in the input, then the default value of `digest_public_key` shall be the current value of `data_public_key`.

ENCRYPTION OUTPUT: The **digest_public_key** pragma expression shall be output in each protected block for which it is used, followed by the encoded value. The **digest_key_method** and **digest_public_key** can be combined to fully specify the required encryption.

DECRYPTION INPUT: The **digest_keyowner** and **digest_key_method** can be combined with the **digest_public_key** to determine whether the decrypting tool knows the corresponding private key to decrypt a given **digest_block**. If the decrypting tool can compute the required key, the model can be decrypted (if licensing allows it).

34.5.20 **digest_decrypt_key**

34.5.20.1 Syntax

```
digest_decrypt_key
```

34.5.20.2 Description

ENCRYPTION INPUT: The **digest_decrypt_key** indicates that the next line contains the encoded value of the key that will decrypt the **digest_block**. This pragma expression should only be used when digital signatures are used. An IP author can generate a key and use it to encrypt the digest. This encrypted text is then stored in the output file as the **digest_block**. Then the **digest_key_method** and **digest_decrypt_key** are encrypted using the **key_method** and stored in the output file as the contents of the **key_block**. The **digest_block** itself is not reencrypted; only the information about the digest key is. If no **digest_decrypt_key** is specified in the input, then the default value of **digest_decrypt_key** shall be the current value of **data_decrypt_key**.

ENCRYPTION OUTPUT: The **digest_decrypt_key** is output as part of the encrypted content of the **key_block**. The value is encoded as specified by the **encoding** pragma expression.

DECRYPTION INPUT: Upon determining that a digital signature was in use for a given protected region, the decrypting tool shall decrypt the **key_block** to find the **digest_decrypt_key** and **digest_key_method** that in turn can be used to decrypt the digest block.

34.5.21 **digest_method**

34.5.21.1 Syntax

```
digest_method = <string>
```

34.5.21.2 Description

ENCRYPTION INPUT: The **digest_method** pragma expression specifies the message digest algorithm that shall be used to generate message digests for subsequent **data_block** and **key_block** output. The string value is an identifier commonly associated with a specific message digest algorithm.

This standard specifies the values [Table 34-4](#) for the `digest_method` pragma expression. Additional identifier values are implementation-defined.

Table 34-4—Message digest algorithm identifiers

Identifier	Required /optional	Message digest algorithm
sha1	Required	Secure Hash Algorithm 1 (SHA-1), see FIPS 180-2.
md5	Required	Message Digest Algorithm 5, see IETF RFC 1321.
md2	Optional	Message Digest Algorithm 2, see IETF RFC 1319.
ripemd-160	Optional	RIPEMD-160, see ISO/IEC 10118-3:2004.

ENCRYPTION OUTPUT: The `digest_method` shall be unchanged in the output file, except where a digital signature is used, in which case it is encrypted with the `key_method` and placed in a `key_block`.

DECRYPTION INPUT: The `digest_method` indicates the algorithm that shall be used to generate the digest from the `data_block`.

34.5.22 `digest_block`

34.5.22.1 Syntax

`digest_block`

34.5.22.2 Description

ENCRYPTION INPUT: If a `digest_block` pragma expression is found in an input file (other than in a `begin_protected-end_protected` block), it shall be treated by the encrypting tool as a request to generate a message digest in the output file.

ENCRYPTION OUTPUT: A message digest is used to verify that the encrypted data have not been modified. The encrypting tool generates the message digest (a fixed-length, computationally unique identifier corresponding to a set of data) using the algorithm specified by the `digest_method` pragma expression and encrypts the message digest as specified by the `digest_key_method` pragma keyword using the key specified by `digest_keyname`, `digest_key_keyowner`, `digest_public_key`, and `digest_decrypt_key`. If `digest_key_method` is not specified for the encryption envelope, then the current `data_method` encryption key shall be used. If the `digest_key_method`, or in its absence the current `data_method`, specifies a cipher-block chaining encryption algorithm that requires an Initialization Vector (IV), then the IV cipher-block shall be prepended to the encrypted digest before encoding is performed.

This digest shall then be encoded using the current `encoding` pragma expression and output on the next line of the output file following the `digest_block` pragma expression. A `digest_block` shall be generated for each `key_block` and `data_block` that are generated in the encryption process and shall immediately follow the `key_block` or `data_block` to which it refers.

DECRYPTION INPUT: In order to authenticate the message, the consuming tool will decrypt the encrypted data, generate a message digest from the decrypted data, decrypt the message digest in the `digest_block` with the specified key, and compare the two message digests. If the two digests do not match, then either the `digest_block` or the encrypted data has been altered since the input data was encrypted. The message digest for a `key_block` or `data_block` shall be contained in a `digest_block` immediately following the

key_block or **data_block**. If the **digest_key_method**, or in its absence the current **data_method**, specifies a cipher-block chaining encryption algorithm that requires an Initialization Vector (IV), then the first cipher-block of the decoded **digest_block** shall be removed for use as the IV. The remainder of the **digest_block** shall be internally decrypted.

34.5.23 key_keyowner

34.5.23.1 Syntax

```
key_keyowner = <string>
```

34.5.23.2 Description

ENCRYPTION INPUT: The **key_keyowner** specifies the legal entity or tool that provided the keys used for encryption and decryption of the key information. The value of the **key_keyowner** also has the same constraints specified for the **data_keyowner** values.

ENCRYPTION OUTPUT: The **key_keyowner** shall be unchanged in the output file.

DECRYPTION INPUT: During decryption, the **key_keyowner** can be combined with the **key_keyname** or **key_public_key** to determine the appropriate secret/private key to use during decryption of the **key_block**.

34.5.24 key_method

34.5.24.1 Syntax

```
key_method = <string>
```

34.5.24.2 Description

ENCRYPTION INPUT: The **key_method** pragma expression indicates the encryption algorithm that shall be used to encrypt the keys used to encrypt the **data_block**. The values specified for **key_method** to identify encryption algorithms are the same as those specified for **data_method**.

ENCRYPTION OUTPUT: The **key_method** shall be unchanged in the output file.

DECRYPTION INPUT: The **key_method** indicates the algorithm that shall be used to decrypt the **key_block**.

34.5.25 key_keyname

34.5.25.1 Syntax

```
key_keyname = <string>
```

34.5.25.2 Description

ENCRYPTION INPUT: The **key_keyname** pragma expression provides the name of the key, or key pair for an asymmetric encryption algorithm, that shall be used to decrypt the **key_block**. It shall be an error to specify a **key_keyname** that is not a member of the list of keys known for the given **key_keyowner**.

ENCRYPTION OUTPUT: When a **key_keyname** is provided in the input, it indicates the key that shall be used for encrypting the data encryption keys. The encrypting tool shall combine this pragma expression with

the **key_keyowner** and determine the key to use. The **key_keyname** itself shall be output as cleartext in the output file.

DECRYPTION INPUT: The **key_keyname** value is combined with the **key_keyowner** to select a single key that shall be used to decrypt the **data_block** from the protected envelope.

34.5.26 **key_public_key**

34.5.26.1 Syntax

key_public_key

34.5.26.2 Description

ENCRYPTION INPUT: The **key_public_key** pragma expression indicates that the next line of the file contains the encoded value of the public key to be used to encrypt the key data. The encoding is specified by the **encoding** pragma expression that is currently in effect. If both a **key_public_key** and **key_keyname** are present, then they shall refer to the same key.

ENCRYPTION OUTPUT: The **key_public_key** pragma expression shall be output in each protected block for which it is used, followed by the encoded value. The **key_method** and **key_public_key** can be combined to fully specify the required encryption of data keys.

DECRYPTION INPUT: The **key_keyowner** and **key_method** can be combined with the **key_public_key** to determine whether the decryption tool knows the corresponding private key to decrypt a given **key_block**. If the decrypting tool can compute the required key, the data keys can be decrypted.

34.5.27 **key_block**

34.5.27.1 Syntax

key_block

34.5.27.2 Description

ENCRYPTION INPUT: It shall be an error if a **key_block** is found in an input file unless it is contained within a previously generated **begin_protected-end_protected** block, in which case it is ignored.

ENCRYPTION OUTPUT: The **key_block** pragma expression indicates that a key block begins on the next line in the file. When requested to use a digital signature, the encrypting tool shall take any of the **data_method**, **data_public_key**, **data_keyname**, **data_decrypt_key**, and **digest_block** to form a text buffer. This buffer shall then be encrypted with the appropriate **key_public_key**, and then the encrypted region shall be encoded using the **encoding** pragma expression in effect. The output of this encoding shall be generated as the contents of the **key_block**. If the **key_method** specifies a cipher-block chaining encryption algorithm that requires an Initialization Vector (IV), then the IV cipher-block shall be prepended to the encrypted key before encoding is performed. Note that encrypting keys with a symmetric cipher is not a common use case.

Where more than one **key_block** pragma expression occurs within a single **begin-end** block, the generated key blocks shall all encode the same data decryption key data. It shall be an error if the data decryption pragma expressions change value between **key_block** pragma expressions of a single encryption envelope. Multiple key blocks are specified for the purpose of providing alternative decryption keys for a single decryption envelope.

DECRYPTION INPUT: The **key_block** is first read in the encoded form, the encoding is reversed, and then the block is internally decrypted. The resulting text is then parsed to determine the keys required to decrypt the **data_block**. If the **key_method** specifies a cipher-block chaining encryption algorithm that requires an Initialization Vector (IV), then the first cipher-block of the decoded **key_block** shall be removed for use as the Initialization Vector. The remainder of the decoded **key_block** shall be internally decrypted.

34.5.28 **decrypt_license**

34.5.28.1 Syntax

```
decrypt_license = ( library = <string> , entry = <string> ,  
                    feature = <string> , [ exit = <string> , ] [ match = <number> ] )
```

34.5.28.2 Description

ENCRYPTION INPUT: The **decrypt_license** pragma expression will typically be found inside a **begin-end** pair in the original cleartext. This is necessary so that it is encrypted in the output IP shipped to the end user.

ENCRYPTION OUTPUT: The **decrypt_license** is output unchanged in the output description except for encryption and encoding of the pragma exactly as other cleartext in the **begin-end** pair. Typically, it will be output in the **data_block**.

DECRYPTION INPUT: After encountering a **decrypt_license** pragma expression in an encrypted model, prior to processing the decrypted text, the application shall load the specified library and call the **entry** function, passing it the **feature** specified string. The return value of the **entry** function shall be compared to the **match** value. If the application is licensed to decrypt the model, the returned value shall compare equal to the **match** value and shall compare nonequal otherwise. If the application is not licensed to decrypt the model, no decryption shall be performed, and the application shall produce an error message that includes the return value of the **entry** function. If an **exit** function is specified, then it shall be called prior to exiting the decrypting application to allow for releasing the license.

NOTE—This mechanism only provides limited security because the end users of the model have the shared library and could use readily available debuggers to debug the calling sequence of the licensing mechanism. They could then produce an equivalent library that returns a 0, but avoids the license check.

34.5.29 **runtime_license**

34.5.29.1 Syntax

```
runtime_license = ( library = <string> , entry = <string> ,  
                    feature = <string> [ , exit = <string> ] [ , match = <number> ] )
```

34.5.29.2 Description

ENCRYPTION INPUT: The **runtime_license** pragma expression will typically be found inside a **begin-end** pair in the original cleartext. This is necessary so that it is encrypted in the output IP shipped to the end user.

ENCRYPTION OUTPUT: The **runtime_license** is output unchanged in the output description except for encryption and encoding of the pragma exactly as other cleartext in the **begin-end** pair.

DECRYPTION INPUT: After encountering a **runtime_license** pragma expression in an encrypted model, prior to executing, the application shall load the specified library and call the entry function, passing

it the **feature** specified string. The return value of the entry function shall be compared to the match value. If the application is licensed to execute the model, the returned value shall compare equal to the match value and shall compare nonequal otherwise. If the application is not licensed to execute the model, execution shall not begin, and the application shall produce an error message that includes the return value of the entry function. If an **exit** is specified, then it shall be called prior to exiting the executing application to allow for releasing the license.

NOTE 1—Execution could mean any evaluation of the model, including simulation, layout, or synthesis.

NOTE 2—This mechanism only provides limited security because the end users of the model have the shared library and could use readily available debuggers to debug the calling sequence of the licensing mechanism. They could then produce an equivalent library that returns a 0, but avoids the license check. IP authors may wish to implement their own licensing scheme embedded within the behavior of the model, possibly using PLI and/or system tasks.

34.5.30 comment

34.5.30.1 Syntax

```
comment = <string>
```

34.5.30.2 Description

ENCRYPTION INPUT: The **comment** pragma expression can be found anywhere in an input file and indicates that even if this is found inside a **begin-end** block, the value shall be output as a comment in cleartext in the output immediately prior to the **data_block**.

This is provided so that comments that may end up being included in other files inside a **begin-end** block can protect themselves from being encrypted. This is important so that critical information such as copyright notices can be explicitly excluded from encryption.

Because this constitutes known cleartext that would be found inside the **data_block**, the pragma itself and the value should not be included in the encrypted text.

ENCRYPTION OUTPUT: The entire comment including the beginning pragma shall be output in cleartext immediately prior to the **data_block** corresponding to the **begin-end** in which the comment was found.

DECRYPTION INPUT: none

34.5.31 reset

34.5.31.1 Syntax

```
reset
```

34.5.31.2 Description

ENCRYPTION INPUT: The **reset** pragma expression is a synonym for a reset pragma directive that contains **protect** in the pragma keyword list. Following the reset, all **protect** pragma keywords are restored to their default values.

Because the scope of pragma definitions is lexical and extends from the point of the directive until the end of the compilation input, if an IP author chooses to put common pragmas such as **author** and **author_info** at the beginning of a list of files, they should include a **reset** pragma at the end of the list of files so that this information is not unintentionally visible in other files.

ENCRYPTION OUTPUT: none

DECRYPTION INPUT: none

34.5.32 viewport

34.5.32.1 Syntax

```
viewport = ( object = <string> , access = <string> )
```

34.5.32.2 Description

The **viewport** pragma expression describes objects within the current protected envelope for which access shall be permitted by the SystemVerilog tool. The specified object name shall be contained within the current envelope. The access value is an implementation-specific relaxation of protection.

Part Three: Application Programming Interfaces

35. Direct programming interface (DPI)

35.1 General

This clause describes the following:

- DPI tasks and functions
- DPI layers
- Importing and exporting functions
- Importing and exporting tasks
- Disabling DPI tasks and functions

35.2 Overview

This clause highlights the DPI and provides a detailed description of the SystemVerilog layer of the interface. The C layer is defined in [Annex H](#).

DPI is an interface between SystemVerilog and a foreign programming language. It consists of two separate layers: the SystemVerilog layer and a foreign language layer. Both sides of DPI are fully isolated. Which programming language is actually used as the foreign language is transparent and irrelevant for the SystemVerilog side of this interface. Neither the SystemVerilog compiler nor the foreign language compiler is required to analyze the source code in the other's language. Different programming languages can be used and supported with the same intact SystemVerilog layer. For now, however, SystemVerilog defines a foreign language layer only for the C programming language. See [Annex H](#) for more details.

The motivation for this interface is two-fold. The methodological requirement is that the interface should allow a heterogeneous system to be built (a design or a testbench) in which some components can be written in a language (or more languages) other than SystemVerilog, hereinafter called the *foreign language*. On the other hand, there is also a practical need for an easy and efficient way to connect existing code, usually written in C or C++, without the knowledge and the overhead of VPI.

DPI follows the principle of a black box: the specification and the implementation of a component are clearly separated, and the actual implementation is transparent to the rest of the system. Therefore, the actual programming language of the implementation is also transparent, although this standard defines only C linkage semantics. The separation between SystemVerilog code and the foreign language is based on using functions as the natural encapsulation unit in SystemVerilog. By and large, any function can be treated as a black box and implemented either in SystemVerilog or in the foreign language in a transparent way, without changing its calls.

35.2.1 Tasks and functions

DPI allows direct inter-language function calls between the languages on either side of the interface. Specifically, functions implemented in a foreign language can be called from SystemVerilog; such functions are referred to as *imported functions*. SystemVerilog functions that are to be called from a foreign code shall be specified in export declarations (see [35.7](#) for more details). DPI allows for passing SystemVerilog data between the two domains through function arguments and results. There is no intrinsic overhead in this interface.

It is also possible to perform task enables across the language boundary. Foreign code can call SystemVerilog tasks, and native SystemVerilog code can call imported tasks. An imported task has the same semantics as a native SystemVerilog task: it never returns a value, and it can consume simulation time.

All functions used in DPI are assumed to complete their execution instantly and consume zero simulation time, just as normal SystemVerilog functions. DPI provides no means of synchronization other than by data exchange and explicit transfer of control.

Every imported subroutine needs to be declared. A declaration of an imported subroutine is referred to as an *import declaration*. Import declarations are very similar to SystemVerilog subroutine declarations. Import declarations can occur anywhere where SystemVerilog subroutine definitions are permitted. An import declaration is considered to be a definition of a SystemVerilog subroutine with a foreign language implementation. The same foreign subroutine can be used to implement multiple SystemVerilog tasks and functions (this can be a useful way of providing differing default argument values for the same basic subroutine), but a given SystemVerilog name can only be defined once per scope. Imported subroutines can have zero or more formal **input**, **output**, and **inout** arguments. Imported tasks always return a void value and thus can only be used in statement context. Imported functions can return a result or be defined as void functions.

DPI is based entirely upon SystemVerilog constructs. The usage of imported functions is identical to the usage of native SystemVerilog functions. With few exceptions, imported functions and native functions are mutually exchangeable. Calls of imported functions are indistinguishable from calls of SystemVerilog functions. This facilitates ease of use and minimizes the learning curve. Similar interchangeable semantics exist between native SystemVerilog tasks and imported tasks.

35.2.2 Data types

SystemVerilog data types are the sole data types that can cross the boundary between SystemVerilog and a foreign language in either direction (i.e., when an imported function is called from SystemVerilog code or an exported SystemVerilog function is called from a foreign code). It is not possible to import the data types or directly use the type syntax from another language. A rich subset of SystemVerilog data types is allowed for formal arguments of import and export functions, although with some restrictions and with some notational extensions. Function result types are restricted to small values, however (see [35.5.5](#)).

Formal arguments of an imported function can be declared as open arrays as specified in [35.5.6.1](#).

35.2.2.1 Data representation

DPI does not add any constraints on how SystemVerilog-specific data types are actually implemented. Optimal representation can be platform dependent. The layout of 2- or 4-state packed structures and arrays is implementation and platform dependent.

The implementation (representation and layout) of 4-state values, structures, and arrays is irrelevant for SystemVerilog semantics and can only impact the foreign side of the interface.

35.3 Two layers of the DPI

DPI consists of two separate layers: the SystemVerilog layer and a foreign language layer. The SystemVerilog layer does not depend on which programming language is actually used as the foreign language. Although different programming languages can be supported and used with the intact SystemVerilog layer, SystemVerilog defines a foreign language layer only for the C programming language. Nevertheless, SystemVerilog code shall look identical and its semantics shall be unchanged for any foreign language layer. Different foreign languages can require that the SystemVerilog implementation shall use the appropriate function call protocol and argument passing and linking mechanisms. This shall be, however, transparent to SystemVerilog users. SystemVerilog requires only that its implementation shall support C protocols and linkage.

35.3.1 DPI SystemVerilog layer

The SystemVerilog side of DPI does not depend on the foreign programming language. In particular, the actual function call protocol and argument passing mechanisms used in the foreign language are transparent and irrelevant to SystemVerilog. SystemVerilog code shall look identical regardless of what code the foreign side of the interface is using. The semantics of the SystemVerilog side of the interface is independent from the foreign side of the interface.

This clause does not constitute a complete interface specification. It only describes the functionality, semantics, and syntax of the SystemVerilog layer of the interface. The other half of the interface, the foreign language layer, defines the actual argument passing mechanism and the methods to access (read/write) formal arguments from the foreign code. See [Annex H](#) for more details.

35.3.2 DPI foreign language layer

The foreign language layer of the interface (which is transparent to SystemVerilog) shall specify how actual arguments are passed, how they can be accessed from the foreign code, how SystemVerilog-specific data types (such as `logic` and `packed`) are represented, and how they are translated to and from some predefined C-like types.

The data types allowed for formal arguments and results of imported functions or exported functions are generally SystemVerilog types (with some restrictions and with notational extensions for open arrays). Users are responsible for specifying in their foreign code the native types equivalent to the SystemVerilog types used in imported declarations or export declarations. Software tools, like a SystemVerilog compiler, can facilitate the mapping of SystemVerilog types onto foreign native types by generating the appropriate function headers.

The SystemVerilog compiler or simulator shall generate and/or use the function call protocol and argument passing mechanisms required for the intended foreign language layer. The same SystemVerilog code (compiled accordingly) shall be usable with different foreign language layers, regardless of the data access method assumed in a specific layer. [Annex H](#) defines the DPI foreign language layer for the C programming language.

35.4 Global name space of imported and exported functions

Every subroutine imported to SystemVerilog shall eventually resolve to a global symbol. Similarly, every subroutine exported from SystemVerilog defines a global symbol. Thus the tasks and functions imported to and exported from SystemVerilog have their own global name space of linkage names, different from compilation-unit scope name space. Global names of imported and exported tasks and functions shall be unique (no overloading is allowed) and shall follow C conventions for naming; specifically, such names shall start with a letter or underscore, and they can be followed by alphanumeric characters or underscores. Exported and imported tasks and functions, however, can be declared with local SystemVerilog names. Import and export declarations allow users to specify a global name for a function in addition to its declared name. Should a global name clash with a SystemVerilog keyword or a reserved name, it shall take the form of an escaped identifier. The leading backslash (\) character and the trailing white space shall be stripped off by the SystemVerilog tool to create the linkage identifier. After this stripping, the linkage identifier so formed shall comply with the normal rules for C identifier construction. If a global name is not explicitly given, it shall be the same as the SystemVerilog subroutine name. For example:

```
export "DPI-C" f_plus = function \f+ ; // "f+" exported as "f_plus"  
export "DPI-C" function f; // "f" exported under its own name  
import "DPI-C" init_1 = function void \init[1] (); // "init_1" is a linkage name  
import "DPI-C" \begin = function void \init[2] (); // "begin" is a linkage name
```

The same global subroutine can be referred to in multiple import declarations in different scopes or/and with different SystemVerilog names (see [35.5.4](#)).

Multiple export declarations are allowed with the same *c_identifier*, explicit or implicit, as long as they are in different scopes and have the equivalent type signature (as defined in [35.5.4](#) for imported tasks and functions). Multiple export declarations with the same *c_identifier* in the same scope are forbidden.

It is possible to use the deprecated "DPI" version string syntax in an import or export declaration. This syntax indicates that the SystemVerilog 2-state and 4-state packed array argument passing convention is to be used (see [H.13](#)). In such cases, all declarations using the same *c_identifier* shall be declared with the same DPI version string syntax.

35.5 Imported tasks and functions

The usage of imported functions is similar as for native SystemVerilog functions.

35.5.1 Required properties of imported tasks and functions—semantic constraints

This subclause defines the semantic constraints imposed on imported subroutines. Some semantic restrictions are shared by all imported subroutines. Other restrictions depend on whether the special properties **pure** (see [35.5.2](#)) or **context** (see [35.5.3](#)) are specified for an imported subroutine. A SystemVerilog compiler is not able to verify that those restrictions are observed; and if those restrictions are not satisfied, the effects of such imported subroutine calls can be unpredictable.

35.5.1.1 Instant completion of imported functions

Imported functions shall complete their execution instantly and consume zero simulation time, similarly to native functions.

NOTE—Imported tasks can consume time, similar to native SystemVerilog tasks.

35.5.1.2 input, output, and inout arguments

Imported functions can have **input**, **output**, and **inout** arguments. The formal **input** arguments shall not be modified. If such arguments are changed within a function, the changes shall not be visible outside the function; the actual arguments shall not be changed.

The imported function shall not assume anything about the initial values of formal **output** arguments. The initial values of **output** arguments are undetermined and implementation dependent.

The imported function can access the initial value of a formal **inout** argument. Changes that the imported function makes to a formal **inout** argument shall be visible outside the function.

35.5.1.3 Special properties pure and context

Special properties can be specified for an imported subroutine as **pure** or as **context** (see also [35.5.2](#) or [35.5.3](#)).

A function whose result depends solely on the values of its input arguments and with no side effects can be specified as **pure**. This can usually allow for more optimizations and thus can result in improved simulation performance. Subclause [35.5.2](#) details the rules that shall be obeyed by pure functions. An imported task can never be declared pure.

An imported subroutine that is intended to call exported subroutines or to access SystemVerilog data objects other than its actual arguments (e.g., via VPI calls) shall be specified as **context**. Calls of context tasks and functions are specially instrumented and can impair SystemVerilog compiler optimizations; therefore, simulation performance can decrease if the **context** property is specified when not necessary. A subroutine not specified as **context** shall not read or write any data objects from SystemVerilog other than its actual arguments. For subroutines not specified as **context**, the effects of calling VPI or exported SystemVerilog subroutines can be unpredictable and can lead to unexpected behavior; such calls can even crash. Subclause [35.5.3](#) details the restrictions that shall be obeyed by noncontext subroutines.

If neither the pure nor the context attribute is used on an imported subroutine, the subroutine shall not access SystemVerilog data objects; however, it can perform side effects such as writing to a file or manipulating a global variable.

35.5.1.4 Memory management

The memory spaces owned and allocated by the foreign code and SystemVerilog code are disjointed. Each side is responsible for its own allocated memory. Specifically, an imported function shall not free the memory allocated by SystemVerilog code (or the SystemVerilog compiler) nor expect SystemVerilog code to free the memory allocated by the foreign code (or the foreign compiler). This does not exclude scenarios where foreign code allocates a block of memory and then passes a handle (i.e., a pointer) to that block to SystemVerilog code, which in turn calls an imported function (e.g., C standard function `free`) that directly or indirectly frees that block.

NOTE—In this last scenario, a block of memory is allocated and freed in the foreign code, even when the standard functions `malloc` and `free` are called directly from SystemVerilog code.

35.5.1.5 Reentrancy of imported tasks

A call to an imported task can result in the suspension of the currently executing thread. This occurs when an imported task calls an exported task, and the exported task executes a delay control, event control, or wait statement. Thus it is possible for an imported task's C code to be simultaneously active in multiple execution threads. Standard reentrancy considerations must be made by the C programmer. Some examples of such considerations include the use of static variables and ensuring that only thread-safe C standard library calls (MT safe) are used.

35.5.1.6 C++ exceptions

It is possible to implement DPI imported tasks and functions using C++, as long as C linkage conventions are observed at the language boundary. If C++ is used, exceptions shall not propagate out of any imported subroutine. Undefined behavior can result if an exception crosses the language boundary from C++ into SystemVerilog.

35.5.2 Pure functions

A **pure** function call can be eliminated if its result is not needed or if the previous result for the same values of input arguments is available somehow and can be reused without needing to recalculate. Only nonvoid functions with no **output** or **inout** arguments can be specified as **pure**. Functions specified as **pure** shall have no side effects whatsoever; their results need to depend solely on the values of their input arguments. Calls to such functions can be removed by SystemVerilog compiler optimizations or replaced with the values previously computed for the same values of the input arguments.

Specifically, a pure function is assumed not to directly or indirectly (i.e., by calling other functions) perform the following:

- Perform any file operations.

- Read or write anything in the broadest possible meaning, including input/output, environment variables, objects from the operating system or from the program or other processes, shared memory, sockets, etc.
- Access any persistent data, like global or static variables.

If a pure function does not obey the above restrictions, SystemVerilog compiler optimizations can lead to unexpected behavior, due to eliminated calls or incorrect results being used.

35.5.3 Context tasks and functions

Some DPI imported subroutines require that the context of their call be known. It takes special instrumentation of their call instances to provide such context; for example, an internal variable referring to the “current instance” might need to be set. To avoid any unnecessary overhead, imported subroutine calls in SystemVerilog code are not instrumented unless the imported subroutine is specified as `context`.

The SystemVerilog context of DPI export tasks and functions must be known when they are called, including when they are called by imports. When an import invokes the `svSetScope` utility prior to calling the export, it sets the context explicitly. Otherwise, the context will be the context of the instantiated scope where the import declaration is located. Because imports with diverse instantiated scopes can export the same subroutine, multiple instances of such an export can exist after elaboration. Prior to any invocations of `svSetScope`, these export instances would have different contexts, which would reflect their imported caller’s instantiated scope.

A foreign language subroutine supported through some other interface (a VPI callback for example), can also make a call to `svSetScope` or to other DPI scope-related APIs. This foreign language subroutine can also call an export subroutine declared in a specific instantiated scope by first making a call to `svSetScope`. The behavior of the DPI scope-related APIs and invocation of DPI export subroutines will be simulator defined and is beyond the scope of the DPI specification.

The concept of *call chains* is useful for understanding how context works as control weaves in and out of SystemVerilog and another language through a DPI interface. For the purpose of this description, an *inter-language call* is between SystemVerilog and a DPI supported language, or vice-versa. An *intra-language call* is between SystemVerilog subroutines themselves, or between subroutines in the DPI support language, i.e., the call does not cross the language boundary.

A DPI import call chain is an inter-language call chain starting from SystemVerilog into a subroutine that is defined in a DPI supported language. The starting point of the call chain from SystemVerilog is called the root of the call chain. This call chain can comprise multiple intra-language and inter-language calls between SystemVerilog and DPI supported language before it unwinds and returns to the calling SystemVerilog subroutine at the root of the import call chain.

The subroutine in the DPI supported language could make intra-language calls within the language and then could unwind and return back to the calling SystemVerilog subroutine. Alternatively, the called import subroutine could make an inter-language call to an export DPI subroutine in the imported caller’s instantiated scope, or by setting another instantiated scope and calling the export DPI routine in that scope. The called export DPI subroutine can make intra-language calls in SystemVerilog, or make an inter-language call to yet another import subroutine or simply return to the calling import subroutine. This nested invocation of inter-language and intra-language calls is considered a part of a single import call chain.

Another key point to note is that the context property applies to each import subroutine call that is made from SystemVerilog. This implies that the context property at the root of the DPI import call chain or any intermediate import call in the call chain is not transitively promoted to subsequent import calls in the DPI

import call chain. Since a noncontext imported DPI subroutine cannot make a call to a SystemVerilog export subroutine, the behavior of making any such calls in the DPI import call chain is an error.

The following behavior characterizes context mechanics for imported call chains:

- The actions below determine an import call chain's context value:
 - When a SystemVerilog subroutine calls a DPI context import, a context for the import call chain is created that is equal to the instantiated scope of the import declaration.
 - When a routine in an import call chain invokes `svSetScope` with a legal argument, the call chain's context is set to the indicated scope.
 - When a call from an import call chain to an exported SystemVerilog subroutine finishes and returns to the chain, the call chain's context is set equal to its value when the call to the export was made.
- Detecting when control moves across the language boundary between SystemVerilog and an imported language is critical for simulators managing DPI context. Therefore, if user code circumvents unwinding an export call chain back to its import chain caller (e.g., by using `C setjmp/longjmp` constructs) the results are undefined.
- Whether a specific import subroutine call in the DPI import call chain is context or not is governed by the context property of the import subroutine to which the call was made. The context property of a previous import subroutine call in the DPI import call chain is not transitively promoted to all subsequent import function calls in the call chain.
- The context characteristic of a DPI import call cannot be dynamically changed after the initial call to the import subroutine in the DPI supported language.
- The context characteristic adheres to the calling-chain, not to an individual imported subroutine; thus, the same imported subroutine can appear in both context and non-context call chains.

For the sake of simulation performance, an imported subroutine call shall not block SystemVerilog compiler optimizations. An imported subroutine not specified as **context** shall not access any data objects from SystemVerilog other than its actual arguments. Only the actual arguments can be affected (read or written) by its call. Therefore, a call of a noncontext subroutine is not a barrier for optimizations. A context imported subroutine, however, can access (read or write) any SystemVerilog data objects by calling VPI or by calling an export subroutine. Therefore, a call to a context subroutine is a barrier for SystemVerilog compiler optimizations.

Only calls of context imported subroutines are properly instrumented and cause conservative optimizations; therefore, only those subroutines can safely call all subroutines from other APIs, including VPI functions or exported SystemVerilog subroutines. For imported subroutines not specified as **context**, the effects of calling VPI functions or SystemVerilog subroutines can be unpredictable; and such calls can crash if the callee requires a context that has not been properly set. However, declaring an import context subroutine does not automatically make any other simulator interface automatically available. For VPI access (or any other interface access) to be possible, the appropriate implementation-defined mechanism shall still be used to enable these interface(s). Realize also that DPI calls do not automatically create or provide any handles or any special environment that can be needed by those other interfaces. It is the user's responsibility to create, manage, or otherwise manipulate the required handles or environment(s) needed by the other interfaces.

Context imported subroutines are always implicitly supplied a scope representing the fully qualified instance name within which the import declaration was present. This scope defines which exported SystemVerilog subroutines can be called directly from the imported subroutine; only subroutines defined and exported from the same scope as the import can be called directly. To call any other exported SystemVerilog subroutines, the imported subroutine shall first have to modify its current scope, in essence performing the foreign language equivalent of a SystemVerilog hierarchical subroutine call.

Special DPI utility functions exist that allow imported subroutines to retrieve and operate on their scope. See [Annex H](#) for more details.

35.5.4 Import declarations

Each imported subroutine shall be declared. Such declaration are referred to as *import declarations*. Imported subroutines are similar to SystemVerilog subroutines. Imported subroutines can have zero or more formal **input**, **output**, and **inout** arguments. Imported functions can return a result or be defined as void functions. Imported tasks always return an **int** result as part of the DPI disable protocol and, thus, are declared in foreign code as **int** functions (see [35.8](#) and [35.9](#)).

```

dpi_import_export ::= //from A.2.6
    import dpi_spec_string [ dpi_function_import_property ] [ c_identifier = ] dpi_function_proto ;
    | import dpi_spec_string [ dpi_task_import_property ] [ c_identifier = ] dpi_task_proto ;
    | export dpi_spec_string [ c_identifier = ] function function_identifier ;
    | export dpi_spec_string [ c_identifier = ] task task_identifier ;
dpi_spec_string ::= "DPI-C" | "DPI"
dpi_function_import_property ::= context | pure
dpi_task_import_property ::= context
dpi_function_proto21,22 ::= function_prototype
dpi_task_proto22 ::= task_prototype
function_prototype ::= function data_type_or_void function_identifier ( [ tf_port_list ] )
task_prototype ::= task task_identifier ( [ tf_port_list ] ) //from A.2.7

```

21) dpi_function_proto return types are restricted to small values, per [35.5.5](#).

22) Formals of dpi_function_proto and dpi_task_proto cannot use pass by reference mode and class types cannot be passed at all; see [35.5.6](#) for a description of allowed types for DPI formal arguments.

Syntax 35-1—DPI import declaration syntax (excerpt from [Annex A](#))

An import declaration specifies the subroutine name, function result type, and types and directions of formal arguments. It can also provide optional default values for formal arguments. Formal argument names are optional unless argument binding by name is needed. An import declaration can also specify an optional subroutine property. Imported functions can have the properties context or pure; imported tasks can have the property **context**.

Because an import declaration is equivalent to defining a subroutine of that name in the SystemVerilog scope in which the import declaration occurs, and thus multiple imports of the same subroutine name into the same scope are forbidden.

NOTE—This declaration scope is particularly important in the case of imported context subroutines (see [35.5.3](#)); for noncontext imported subroutines the declaration scope has no other implications other than defining the visibility of the subroutine.

The *dpi_spec_string* can take values "DPI-C" and "DPI". "DPI" is used to indicate that the deprecated SystemVerilog packed array argument passing semantics is to be used. In this semantics, arguments are passed in actual simulator representation format rather than in canonical format, as is the case with "DPI-C".

Use of the string "DPI" shall generate a compile-time warning or error. The tool generated message shall contain the following information:

- "DPI" is deprecated and should be replaced with "DPI-C".
- Use of the "DPI-C" string may require changes in the DPI application's C code.

For more information on using deprecated "DPI" access to packed data, see [H.13](#).

The *c_identifier* provides the linkage name for this subroutine in the foreign language. If not provided, this defaults to the same identifier as the SystemVerilog subroutine name. In either case, this linkage name shall conform to C identifier syntax. An error shall occur if the *c_identifier*, either directly or indirectly, does not conform to these rules.

For any given *c_identifier* (whether explicitly defined with *c_identifier*= or automatically determined from the subroutine name), all declarations, regardless of scope, shall have exactly the same type signature. The signature includes the return type and the number, order, direction, and types of each and every argument. The type includes dimensions and bounds of any arrays or array dimensions. The signature also includes the **pure/context** qualifiers that can be associated with an import definition, and it includes the value of the *dpi_spec_string*.

It is permitted to have multiple declarations of the same imported or exported subroutine in different scopes; therefore, argument names and default values can vary, provided the type compatibility constraints are met.

A formal argument name is required to separate the packed and the unpacked dimensions of an array.

The qualifier **ref** cannot be used in import declarations. The actual implementation of argument passing depends solely on the foreign language layer and its implementation and shall be transparent to the SystemVerilog side of the interface.

The following are examples of external declarations:

```
import "DPI-C" function void myInit();

// from standard math library
import "DPI-C" pure function real sin(real);

// from standard C library: memory management
import "DPI-C" function chandle malloc(int size); // standard C function
import "DPI-C" function void free(chandle ptr); // standard C function

// abstract data structure: queue
import "DPI-C" function chandle newQueue(input string name_of_queue);

// Note the following import uses the same foreign function for
// implementation as the prior import, but has different SystemVerilog name
// and provides a default value for the argument.
import "DPI-C" newQueue=function chandle newAnonQueue(input string s=null);
import "DPI-C" function chandle newElem(bit [15:0]);
import "DPI-C" function void enqueue(chandle queue, chandle elem);
import "DPI-C" function chandle dequeue(chandle queue);

// miscellanea
import "DPI-C" function bit [15:0] getStimulus();
import "DPI-C" context function void processTransaction(chandle elem,
                                                    output logic [64:1] arr [0:63]);
import "DPI-C" task checkResults(input string s, bit [511:0] packet);
```

35.5.5 Function result

An imported function declaration shall explicitly specify a data type or void for the type of the function's return result. Function result types are restricted to small values. The following SystemVerilog data types are allowed for imported function results:

- **void, byte, shortint, int, longint, real, shortreal,chandle, and string**
- Scalar values of type **bit** and **logic**

The same restrictions apply for the result types of exported functions.

35.5.6 Types of formal arguments

A rich subset of SystemVerilog data types is allowed for formal arguments of import and export subroutines. Generally, C-compatible types, packed types, and user-defined types built of types from these two categories can be used for formal arguments of DPI subroutines. The set of permitted types is defined inductively.

The following SystemVerilog types are the only permitted types for formal arguments of import and export subroutines:

- **void, byte, shortint, int, longint, real, shortreal,chandle, time, integer, and string**
- Scalar values of type **bit** and **logic**
- Packed arrays, structs, and unions composed of types **bit** and **logic**. Every packed type is eventually equivalent to a packed one-dimensional array. On the foreign language side of the DPI, all packed types are perceived as packed one-dimensional arrays regardless of their declaration in the SystemVerilog code.
- Enumeration types interpreted as the type associated with that enumeration
- Types constructed from the supported types with the help of the constructs:
 - **struct**
 - **union** (packed forms only)
 - Unpacked array
 - **typedef**

The following caveats apply for the types permitted in DPI:

- Enumerated data types are not supported directly. Instead, an enumerated data type is interpreted as the type associated with that enumerated type.
- SystemVerilog does not specify the actual memory representation of packed structures or any arrays, packed or unpacked. Unpacked structures have an implementation-dependent packing, normally matching the C compiler.
- In exported DPI subroutines, it is erroneous to declare formal arguments of dynamic array types.
- The actual memory representation of SystemVerilog data types is transparent for SystemVerilog semantics and irrelevant for SystemVerilog code. It can be relevant for the foreign language code on the other side of the interface, however; a particular representation of the SystemVerilog data types can be assumed. This shall not restrict the types of formal arguments of imported subroutines, with the exception of unpacked arrays. SystemVerilog implementation can restrict which SystemVerilog unpacked arrays are passed as actual arguments for a formal argument that is a sized array, although they can be always passed for an unsized (i.e., open) array. Therefore, the correctness of an actual argument might be implementation dependent. Nevertheless, an open array provides an implementation-independent solution.

35.5.6.1 Open arrays

The size of the packed dimension, the unpacked dimension, or both dimensions can remain unspecified; such cases are referred to as *open arrays* (or *unsized arrays*). Open arrays allow the use of generic code to handle different sizes.

Formal arguments of imported functions can be specified as open arrays. (Exported SystemVerilog functions cannot have formal arguments specified as open arrays.) A formal argument is an open array when a range of one or more of its dimensions is unspecified (denoted by using square brackets, []). This is solely a relaxation of the argument-matching rules. An actual argument shall match the formal one regardless of the range(s) for its corresponding dimension(s), which facilitates writing generalized code that can handle SystemVerilog arrays of different sizes.

Although the packed part of an array can have an arbitrary number of sized dimensions, an unsized dimension shall be the sole packed dimension of a formal argument. This is not very restrictive, because any packed type is essentially equivalent to a one-dimensional packed array. The number of unpacked dimensions is not restricted.

If a formal argument has an unsized, packed dimension, it will match any collection of actual argument packed dimensions. Formal argument unpacked dimensions are matched on a dimension by dimension basis (see 7.7) with each unsized formal dimension matching a corresponding actual dimension of any size.

The following are examples of types of formal arguments (empty square brackets [] denote open array):

```
logic
bit [8:1]
bit []
bit [7:0] array8x10 [1:10] // array8x10 is a formal arg name
logic [31:0] array32xN [] // array32xN is a formal arg name
logic [] arrayNx3 [3:1] // arrayNx3 is a formal arg name
bit [] arrayNxN [] // arrayNxN is a formal arg name
```

The following is an example of complete import declarations:

```
import "DPI-C" function void f1(input logic [127:0]);
import "DPI-C" function void f2(logic [127:0] i []); //open array of 128-bit
```

The following is an example of the use of open arrays for different sizes of actual arguments:

```
typedef struct {int i; ... } MyType;

import "DPI-C" function void f3(input MyType i [][]);
/* 2-dimensional unsized unpacked array of MyType */

MyType a_10x5 [11:20][6:2];
MyType a_64x8 [64:1][-1:-8];

f3(a_10x5);
f3(a_64x8);
```

35.6 Calling imported functions

The usage of imported functions is identical to the usage of native SystemVerilog functions. Hence the usage and syntax for calling imported functions is identical to the usage and syntax of native SystemVerilog

functions. Specifically, arguments with default values can be omitted from the call; arguments can be bound by name if all formal arguments are named.

35.6.1 Argument passing

Argument passing for imported functions is ruled by the WYSIWYG principle: What You Specify Is What You Get (see [35.6.1.1](#)). The evaluation order of formal arguments follows general SystemVerilog rules.

Argument compatibility and coercion rules are the same as for native SystemVerilog functions. If a coercion is needed, a temporary variable is created and passed as the actual argument. For `input` and `inout` arguments, the temporary variable is initialized with the value of the actual argument with the appropriate coercion. For `output` or `inout` arguments, the value of the temporary variable is assigned to the actual argument with the appropriate conversion. The assignments between a temporary and the actual argument follow general SystemVerilog rules for assignments and automatic coercion.

On the SystemVerilog side of the interface, the values of actual arguments for formal input arguments of imported functions shall not be affected by the callee. The initial values of formal output arguments of imported functions are unspecified (and can be implementation dependent), and the necessary coercions, if any, are applied as for assignments. Imported functions shall not modify the values of their input arguments.

For the SystemVerilog side of the interface, the semantics of arguments passing is as if `input` arguments are passed by *copy-in*, `output` arguments are passed by *copy-out*, and `inout` arguments were passed by *copy-in*, *copy-out*. The terms *copy-in* and *copy-out* do not impose the actual implementation; they refer only to “hypothetical assignment.”

The actual implementation of argument passing is transparent to the SystemVerilog side of the interface. In particular, it is transparent to SystemVerilog whether an argument is actually passed by value or by reference. The actual argument passing mechanism is defined in the foreign language layer. See [Annex H](#) for more details.

35.6.1.1 WYSIWYG principle

The WYSIWYG principle guarantees the types of formal arguments of imported functions: an actual argument is guaranteed to be of the type specified for the formal argument, with the exception of open arrays (for which unspecified ranges are statically unknown). Formal arguments, other than open arrays, are fully defined by import declaration; they shall have ranges of packed or unpacked arrays exactly as specified in the import declaration. Only the declaration site of the imported function is relevant for such formal arguments.

Another way to state this is that no compiler (either C or SystemVerilog) can make argument coercions between a caller’s declared formal and the callee’s declared formals. This is because the callee’s formal arguments are declared in a different language from the caller’s formal arguments; hence there is no visible relationship between the two sets of formals. Users are expected to understand all argument relationships and provide properly matched types on both sides of the interface.

The unsized dimensions of open array formal arguments have the size of the corresponding actual argument dimensions. A formal’s unsized, unpacked dimensions take on the ranges of the corresponding actual dimension. A solitary, unsized, packed dimension assumes the linearized, normalized range of the actual’s packed dimensions (see [H.7.6](#)). The unsized ranges of open arrays are determined at a call site; the rest of the type information is specified at the import declaration.

Therefore, if a formal argument is declared as `bit [15:8] b []`, then the import declaration specifies that the formal argument is an unpacked array of packed bit array with bounds 15 to 8, while the actual argument used at a particular call site defines the bounds for the unpacked part for that call.

It is sometimes permissible to pass a dynamic array as an actual argument to an imported DPI subroutine. The rules for passing dynamic array actual arguments to imported DPI tasks and functions are identical to the rules for native SystemVerilog tasks and functions. Refer to [7.7](#) for details on such use of dynamic arrays.

35.6.2 Value changes for output and inout arguments

The SystemVerilog simulator is responsible for handling value changes for **output** and **inout** arguments. Such changes shall be detected and handled after control returns from imported functions to SystemVerilog code.

For **output** and **inout** arguments, the value propagation (i.e., value change events) happens as if an actual argument was assigned a formal argument immediately after control returns from imported functions. If there is more than one argument, the order of such assignments and the related value change propagation follows general SystemVerilog rules.

35.7 Exported functions

DPI allows calling SystemVerilog functions from another language. However, such functions shall adhere to the same restrictions on argument types and results as imposed on imported functions. It is an error to export a function that does not satisfy such constraints. Declaring a SystemVerilog function to be exported does not change its semantics or behavior from the SystemVerilog perspective; there is no effect on SystemVerilog usage other than making it possible for foreign language tasks and functions in a DPI call-chain to call the exported function.

SystemVerilog functions that can be called from foreign code need to be specified in **export** declarations. Export declarations are allowed to occur only in the scope in which the function being exported is defined. Only one export declaration per function is allowed in a given scope.

One important restriction exists. Class member functions cannot be exported, but all other SystemVerilog functions can be exported.

Similar to import declarations, **export** declarations can define an optional *c_identifier* to be used in the foreign language when calling an exported function.

```
dpi_import_export ::= // from A.2.6  
...  
| export dpi_spec_string [ c_identifier = ] function function_identifier ;  
...  
dpi_spec_string ::= "DPI-C" | "DPI"
```

Syntax 35-2—DPI export declaration syntax (excerpt from [Annex A](#))

The *c_identifier* is optional here. It defaults to *function_identifier*. For rules describing *c_identifier*, see [35.4](#). No two functions in the same SystemVerilog scope can be exported with the same explicit or implicit *c_identifier*. The export declaration and the definition of the corresponding SystemVerilog function can occur in any order. Only one export declaration is permitted per SystemVerilog function, and all export functions are always context functions.

35.8 Exported tasks

SystemVerilog allows tasks to be called from a foreign language, similar to functions. Such tasks are termed *exported tasks*.

All aspects of exported functions described above in [35.7](#) apply to exported tasks. This includes legal declaration scopes as well as usage of the optional *c_identifier*.

It is never legal to call an exported task from within an imported function. This semantics is identical to native SystemVerilog semantics, in which it is illegal for a function to perform a task enable.

It is legal for an imported task to call an exported task only if the imported task is declared with the **context** property. See [35.5.3](#) for more details.

One difference between exported tasks and exported functions is that SystemVerilog tasks do not have return value types. The return value of an exported task is an **int** value that indicates if a disable is active or not on the current execution thread.

Similarly, imported tasks return an **int** value that is used to indicate that the imported task has acknowledged a disable. See [35.9](#) for more detail on disables in DPI.

35.9 Disabling DPI tasks and functions

It is possible for a **disable** statement to disable a block that is currently executing a mixed language call chain. When a DPI import subroutine is disabled, the C code is required to follow a simple disable protocol. The protocol gives the C code the opportunity to perform any necessary resource cleanup, such as closing open file handles, closing open VPI handles, or freeing heap memory.

An imported subroutine is said to be in the disabled state when a **disable** statement somewhere in the design targets either it or a parent for disabling. An imported subroutine can only enter the disabled state immediately after the return of a call to an exported subroutine. An important aspect of the protocol is that disabled import tasks and functions shall programmatically acknowledge that they have been disabled. A subroutine can determine that it is in the disabled state by calling the API function `svIsDisabledState()`.

The protocol is composed of the following items:

- a) When an exported task returns due to a disable, it shall return a value of 1. Otherwise, it shall return 0.
- b) When an imported task returns due to a disable, it shall return a value of 1. Otherwise, it shall return 0.
- c) Before an imported function returns due to a disable, it shall call the API function `svAckDisabledState()`.
- d) Once an imported subroutine enters the disabled state, it is illegal for the current function call to make any further calls to exported subroutines.

Item b), item c), and item d) are mandatory behavior for imported DPI tasks and functions. It is the responsibility of the DPI programmer to correctly implement the behavior.

Item a) is guaranteed by SystemVerilog simulators. In addition, simulators shall implement checks to verify that item b), item c), and item d) are correctly followed by imported tasks and functions. If any protocol item is not correctly followed, a fatal simulation error is issued.

The foreign language side of the DPI contains a disable protocol which is realized by user code working together with a simulator. The disable protocol allows for foreign models to participate in SystemVerilog disable processing. The participation is done through special return values for DPI tasks, and special API calls for DPI functions.

The special return values do not require a change in call syntax, of either import or export DPI tasks in the SystemVerilog code. While the return value for an export task is guaranteed by the simulator, for the import task the return value has to be ensured by the DPI application.

Calls to import tasks in SystemVerilog code are indistinguishable from calls to native SystemVerilog tasks. Likewise, calls to DPI export tasks in SystemVerilog code are indistinguishable from calls to non DPI SystemVerilog tasks.

If an exported task itself is the target of a disable, its parent imported task is not considered to be in the disabled state when the exported task returns. In such cases, the exported task shall return value 0, and calls to `svIsDisabledState()` shall return 0 as well.

When a DPI imported subroutine returns due to a disable, the values of its `output` and `inout` parameters are undefined. Similarly, function return values are undefined when an imported function returns due to a disable. C programmers can return values from disabled functions, and C programmers can write values into the locations of `output` and `inout` parameters of imported subroutines. However, SystemVerilog simulators are not obligated to propagate any such values to the calling SystemVerilog code if a disable is in effect.

36. Programming language interface (PLI/VPI) overview

36.1 General

This clause describes the following:

- The definition and history of PLI and VPI
- User-defined system tasks and system functions
- VPI `sizetf`, `compiletf` and `calltf` routines
- The PLI mechanism
- Access to SystemVerilog and simulation objects
- List of VPI routines by functional category

36.2 PLI purpose and history

The *Programming Language Interface* (PLI) is a procedural interface that allows foreign language functions to access the internal data structures of a SystemVerilog simulation. The SystemVerilog *Verification Procedural Interface* (VPI) is part of the PLI. VPI provides a library of C-language functions and a mechanism for associating foreign language functions with SystemVerilog user-defined system task and system function names.

The PLI provides a means for SystemVerilog users to dynamically access and modify data in an instantiated SystemVerilog data structure. An instantiated SystemVerilog data structure is the result of compiling and elaborating SystemVerilog source descriptions and generating the hierarchy modeled by module instances, primitive instances, and other SystemVerilog constructs that represent scope. The PLI procedural interface provides a library of C language functions that can directly access data within an instantiated SystemVerilog data structure.

A few of the many possible applications for the PLI procedural interface are as follows:

- C language delay calculators for SystemVerilog model libraries that can dynamically scan the data structure of a SystemVerilog tool and then dynamically modify the delays of each instance of models from the library
- C language applications that dynamically read test vectors or other data from a file and pass the data into a SystemVerilog tool
- Custom graphical waveform and debugging environments for SystemVerilog software products
- Source code decompilers that can generate SystemVerilog source code from the compiled data structure of a SystemVerilog tool
- Simulation models written in the C language and dynamically linked into SystemVerilog simulations
- Interfaces to actual hardware, such as a hardware modeler, that dynamically interact with simulations

The following are the three primary generations of the SystemVerilog PLI:

- a) *Task/function* routines, called *TF* routines, made up the first generation of the PLI. These routines, most of which started with the characters `tf_`, were primarily used for operations involving user-defined system task and system function arguments, along with utility functions, such as setting up call-back mechanisms and writing data to output devices. The TF routines were sometimes referred to as *utility* routines
- b) *Access* routines, called *ACC* routines, formed the second generation of the PLI. These routines, which all started with the characters `acc_`, provided an object-oriented access directly into a

SystemVerilog structural description. ACC routines were used to access and modify information, such as delay values and logic values, on a wide variety of objects that exist in a SystemVerilog description. There was some overlap in functionality between ACC routines and TF routines.

- c) The SystemVerilog *Verification Procedural Interface* routines, called *VPI* routines, are the third generation of the PLI. These routines, most of which start with the characters **vpi_**, provide an object-oriented access for SystemVerilog structural, behavioral, assertion, and coverage objects. The VPI routines are a superset of the functionality of the TF routines and ACC routines.

NOTE—IEEE Std 1364-2005 deprecated the task/function (TF) and access (ACC) routines. These deprecated routines are not included in this standard. See Clause 21 through Clause 25, Annex E, and Annex F of IEEE Std 1364-2001 for the deprecated text.

This clause, along with [Clause 38](#), [Annex K](#) and [Annex M](#), describes the VPI procedural interface standard and interface mechanisms.

36.3 User-defined system task and system function names

A user-defined system task or system function name is the name that will be used within a SystemVerilog source file to invoke specific PLI applications. The name shall adhere to the following rules:

- The first character of the name shall be the dollar sign (\$).
- The remaining characters shall be letters, digits, the underscore character (`_`), or the dollar sign (\$).
- Uppercase and lowercase letters shall be considered to be unique—the name is case sensitive.
- The name can be any size, and all characters are significant.

36.3.1 Defining system task and system function names

User-defined system task and system function names are defined using a system task and system function callback registry, which is part of the PLI mechanism. Registering system tasks and system functions is described in [36.9.1](#).

36.3.2 Overriding built-in system task and system function names

[Clause 20](#) and [Clause 21](#) define a number of built-in system tasks and system functions that are part of the SystemVerilog language. In addition, SystemVerilog tools can include other built-in system tasks and system functions specific to the tool. These built-in system task and system function names begin with the dollar sign (\$) just as user-defined system task and system function names.

If a user-provided PLI application is associated with the same name as a built-in system task or system function (using the PLI mechanism), the user-provided C application shall override the built-in system task or system function, replacing its functionality with that of the user-provided C application. For example, a user could write a random number generator as a PLI application and then associate the application with the name `$random`, thereby overriding the built-in `$random` function with the user's application.

SystemVerilog timing checks, such as `$setup`, are not system tasks and cannot be overridden.

The built-in system functions `$signed` and `$unsigned` can be overridden. These system functions are unique in that the return width is based on the width of their argument. If overridden, the PLI version shall have the same return width for all instances of the system function. The PLI return width is defined by the PLI `sizetf` routine.

36.4 User-defined system task and system function arguments

When a user-defined system task or system function is used in a SystemVerilog source file, it can have arguments that can be used by the PLI applications associated with the system task or system function. In the following example, the user-defined system task `$get_vector` has two arguments:

```
$get_vector("test_vector.pat", input_bus);
```

The arguments to a system task or system function are referred to as *task/function arguments* (often abbreviated as *tfargs*). These arguments are not the same as C language arguments. When the PLI applications associated with a user-defined system task or system function are called, the task/function arguments are not passed to the PLI application. Instead, a number of PLI routines are provided that allow the PLI applications to read and write to the task/function arguments. See [Clause 38](#) for information on specific routines that work with task/function arguments.

36.5 User-defined system task and system function types

The type of a user-defined system task or system function determines how a PLI application is called from the SystemVerilog source code. The types are as follows:

- A user *task* can be used in the same places a SystemVerilog task can be used (see [13.3](#)). A user-defined system task can read and modify the arguments of the task, but does not return any value.
- A user *function* can be used in the same places a SystemVerilog function can be used (see [13.4](#)). A user-defined system function can read and modify the arguments of the function, and it returns a value. The bit width of a vector shall be determined by a user-supplied *sizetf* application (see [36.8.1](#)).

36.6 User-supplied PLI applications

User-supplied PLI applications are C language functions that utilize the library of PLI C functions to access and interact dynamically with SystemVerilog software implementations as the SystemVerilog source code is executed.

These PLI applications are not independent C programs. They are C functions that are linked into a tool and become part of the tool. This allows the PLI application to be called when the user-defined system task or system function `$ name` is compiled or executed in the SystemVerilog source code (see [36.8](#)).

36.7 PLI include files

The libraries of PLI functions are defined in C include files, which are a normative part of this standard. These files also define constants, structures, and other data used by the library of PLI routines and the interface mechanisms. These files are `vpi_user.h` (listed in [Annex K](#)) and `sv_vpi_user.h` (listed in [Annex M](#)). PLI applications that use the VPI routines shall include these files.

36.8 VPI *sizetf*, *compiletf* and *calltf* routines

VPI-based system tasks have *sizetf*, *compiletf*, and *calltf* routines, which perform specific actions for the task or system function. The *sizetf*, *compiletf*, and *calltf* routines are called during specific periods during processing. The purpose of each of these routines is explained in [36.8.1](#) through [36.8.4](#).

36.8.1 *size*tf VPI application routine

A *size*tf VPI application routine can be used in conjunction with user-defined system functions. A function shall return a value, and tools that execute the system function need to determine how many bits wide that return value shall be. When *size*tf shall be called is described in [36.10.2](#) and [38.37.1](#). Each *size*tf routine shall be called at most once. It shall be called if its associated system function appears in the design. The value returned by the *size*tf routine shall be the number of bits that the *call*tf routine shall provide as the return value for the system function. If no *size*tf routine is specified, a user-defined system function shall return 32 bits. The *size*tf routine shall not be called for user-defined system tasks or for functions whose *sysfunctype* is set to **vpirealFunc**.

36.8.2 *compile*tf VPI application routine

A *compile*tf VPI application routine shall be called when the user-defined system task or system function name is encountered during parsing or compiling the SystemVerilog source code. This routine is typically used to check the correctness of any arguments passed to the user-defined system task or system function in the SystemVerilog source code. The *compile*tf routine shall be called one time for each instance of a system task or system function in the source description. Providing a *compile*tf routine is optional, but it is recommended that any arguments used with the system task or system function be checked for correctness to avoid problems when the *call*tf or other PLI routines read and perform operations on the arguments. When the *compile*tf is called is described in [36.10.2](#) and [38.37.1](#).

36.8.3 *call*tf VPI application routine

A *call*tf VPI application routine shall be called each time the associated user-defined system task or system function is executed within the SystemVerilog source code. For example, the following SystemVerilog loop would call the *call*tf routine that is associated with the `$get_vector` user-defined system task name 1024 times:

```
for (i = 1; i <= 1024; i = i + 1)
    @(posedge clk) $get_vector("test_vector.pat", input_bus);
```

In this example, the *call*tf might read a test vector from a file called `test_vector.pat` (the first task/function argument), perhaps manipulate the vector to put it in a proper format for SystemVerilog, and then assign the vector value to the second task/function argument called `input_bus`.

36.8.4 Arguments to *size*tf, *compile*tf, and *call*tf application routines

The *size*tf, *compile*tf, and *call*tf routines all take one argument. When the tool calls these routines, it will pass to them the value supplied in the `s_vpi_sysf_data` structure's *user_data* field when the user-defined system task or system function was registered. See [38.37](#).

36.9 PLI mechanism

The PLI mechanism provides a means to have PLI applications called for various reasons when the associated system task and system function \$ name is encountered in the SystemVerilog source description. For example, when a SystemVerilog simulator first compiles the SystemVerilog source description, a specific *compile*tf PLI routine can be called that performs syntax checking to verify the user-defined system task or system function is being used correctly. Then, as simulation is executing, a specific *call*tf PLI routine can be called to perform the operations required by the PLI application. User-defined system tasks and system functions, and their associated routines and data, are defined by registering *system* task and system function *callbacks* (see [36.9.1](#)).

The PLI mechanism also enables having specific PLI applications automatically called by the simulator for miscellaneous reasons, such as the end of a simulation time step or a logic value change on a specific signal. This dynamic interaction with simulation is accomplished by registering *simulation callbacks* (see [36.9.2](#)).

36.9.1 Registering user-defined system tasks and system functions

User-defined system tasks and system functions are created using the routine `vpi_register_systf()` (see [38.37](#)). The registration of system tasks shall occur prior to elaboration or the resolution of references.

The intended use model would be to place a reference to a routine within the `vlog_startup_routines[]` array. This routine would register all user-defined system tasks and system functions when it is called.

Through the VPI, an application can perform the following:

- Specify a user-defined system task or system function name that can be included in SystemVerilog source descriptions; the user-defined system task and system function name shall begin with a dollar sign (\$), such as `$get_vector`.
- Provide one or more PLI C applications to be called by a tool (such as a logic simulator).
- Define which PLI C applications are to be called—and when the applications should be called—when the user-defined system task and system function name is encountered in the SystemVerilog source description.
- Define whether the PLI applications should be treated as *functions* (which return a value) or *tasks* (analogous to subroutines in other programming languages).
- Define a data argument to be passed to the PLI applications each time they are called.

36.9.2 Registering simulation callbacks

Dynamic tool interaction shall be accomplished with a registered callback mechanism. VPI callbacks allow an application to request that a SystemVerilog tool, such as a logic simulator, call a user-defined application when a specific activity occurs. For example, the application can request that the application routine `my_monitor()` be called when a particular net changes value or that `my_cleanup()` be called when the tool execution has completed.

The VPI simulation callback facility shall provide the application with the means to interact dynamically with a tool, detecting the occurrence of value changes, advancement of time, end of simulation, etc. This feature allows integration with other simulation systems, specialized timing checks, complex debugging features, etc.

The reasons for which callbacks shall be provided can be separated into the following four categories:

- *Simulation event* (e.g., a value change on a net or a behavioral statement execution)
- *Simulation time* (e.g., the end of a time queue or after certain amount of time)
- *Simulator action or feature* (e.g., the end of compile, end of simulation, restart, or enter interactive mode)
- *User-defined system task or system function execution*

VPI simulation callbacks shall be registered by the application with the function `vpi_register_cb()` (see [38.36](#)). This routine indicates the specific reason for the callback, the application routine to be called, and what system and *user data* shall be passed to the callback application when the callback occurs. A facility is also provided to call the callback functions when a SystemVerilog tool is first invoked. A primary use of this facility shall be for registration of user-defined system tasks and system functions.

36.10 VPI access to SystemVerilog objects and simulation objects

Accessible SystemVerilog objects and simulation objects and their relationships and properties are described using *data model diagrams*. These diagrams are presented in [Clause 37](#). The data model diagrams indicate the routines and constants that are required to access and manipulate objects within an application environment. An associated set of routines to access these objects is defined in [Clause 38](#).

VPI also includes a set of utility routines for functions such as handle comparison, file handling, and redirected printing, which are described in [Table 36-9](#) (in [36.11](#)).

VPI routines provide access to objects in an *instantiated* SystemVerilog design. An instantiated design is one where each instance of an object is uniquely accessible. For instance, if a module *m* contains wire *w* and is instantiated twice as *m1* and *m2*, then *m1.w* and *m2.w* are two distinct objects, each with its own set of related objects and properties.

VPI is designed as a *simulation* interface, with access to both SystemVerilog objects and specific simulation objects. This simulation interface is different from a hierarchical language interface, which would provide access to source code information, but would not provide information about simulation objects.

36.10.1 Error handling

To determine whether an error occurred, the routine **vpi_chk_error()** (see [38.2](#)) shall be provided. The **vpi_chk_error()** routine shall return a nonzero value if an error occurred in the previously called VPI routine. Callbacks can be set up for when an error occurs as well. The **vpi_chk_error()** routine can provide detailed information about the error.

36.10.2 Function availability

Certain features of VPI shall occur early in the execution of a tool. In order to allow this process to occur in an orderly manner, some functionality shall be restricted in these early stages. Specifically, when the routines within the **vlog_startup_routines[]** array are executed, there is very little functionality available. Only the following two routines can be called at this time:

- **vpi_register_systf()** (see [38.37](#))
- **vpi_register_cb()** (see [38.36](#))

In addition, the **vpi_register_cb()** routine can only be called for the following reasons:

- **cbEndOfCompile**
- **cbStartOfSimulation**
- **cbEndOfSimulation**
- **cbUnresolvedSystf**
- **cbError**
- **cbPLIError**

See [38.37](#) for a further explanation of the use of the **vlog_startup_routines[]** array.

The next earliest phase is when the *size* routines are called for the user-defined system functions. At this phase, no additional access is permitted. After the *size* routines are called, the routines registered for reason **cbEndOfCompile** are called. At this point, and continuing until the tool has finished execution, all functionality is available.

36.10.3 Traversing expressions

The VPI routines provide access to any expression that can be written in the source code. Dealing with these expressions can be complex because very complex expressions can be written in the source code. Expressions with multiple operands will result in a handle of type **vpiOperation**. To determine how many operands, access the property **vpiOpType**. This operation will be evaluated after its subexpressions. Therefore, it has the least precedence in the expression.

An example of a routine that traverses an entire complex expression is listed as follows:

```
void traverseExpr(vpiHandle expr)
{
    vpiHandle subExprI, subExprH;

    switch (vpi_get(vpiExpr, expr))
    {
        case vpiOperation:
            subExprI = vpi_iterate(vpiOperand, expr);
            if (subExprI)
                while (subExprH = vpi_scan(subExprI))
                    traverseExpr(subExprH);
            /* else it is of op type vpiNullOp */
            break;
        default:
            /* Do whatever to the leaf object. */
            break;
    }
}
```

36.11 List of VPI routines by functional category

The VPI routines can be divided into the following groups based on primary functionality:

- Simulation-related callbacks
- System task and system function callbacks
- Traversing SystemVerilog hierarchy
- Accessing properties of objects
- Accessing objects from properties
- Delay processing
- Logic and strength value processing
- Simulation time processing
- Miscellaneous utilities

[Table 36-1](#) through [Table 36-9](#) list the VPI routines by major category. [Clause 38](#) defines each of the VPI routines, listed in alphabetical order.

Table 36-1—VPI routines for simulation-related callbacks

To	Use
Register a simulation-related callback	vpi_register_cb()
Remove a simulation-related callback	vpi_remove_cb()
Get information about a simulation-related callback	vpi_get_cb_info()

Table 36-2—VPI routines for system task or system function callbacks

To	Use
Register a system task or system function callback	<code>vpi_register_systf()</code>
Get information about a system task or system function callback	<code>vpi_get_systf_info()</code>

Table 36-3—VPI routines for traversing SystemVerilog hierarchy

To	Use
Obtain a handle for an object with a one-to-one relationship	<code>vpi_handle()</code>
Obtain handles for objects in a one-to-many relationship	<code>vpi_iterate()</code> <code>vpi_scan()</code>
Obtain a handle for an object in a many-to-one relationship	<code>vpi_handle_multi()</code>

Table 36-4—VPI routines for accessing properties of objects

To	Use
Get the value of objects with types of <code>int</code> or <code>bool</code>	<code>vpi_get()</code>
Get the value of a 64 bit integer property of an object	<code>vpi_get64()</code>
Get the value of objects with types of <code>string</code>	<code>vpi_get_str()</code>

Table 36-5—VPI routines for accessing objects from properties

To	Use
Obtain a handle for a named object	<code>vpi_handle_by_name()</code>
Obtain a handle for an indexed object	<code>vpi_handle_by_index()</code>
Obtain a handle to a word or bit in an array	<code>vpi_handle_by_multi_index()</code>

Table 36-6—VPI routines for delay processing

To	Use
Retrieve delays or timing limits of an object	<code>vpi_get_delays()</code>
Write delays or timing limits to an object	<code>vpi_put_delays()</code>

Table 36-7—VPI routines for logic and strength value processing

To	Use
Retrieve logic value or strength value of an object	<code>vpi_get_value()</code>
Write logic value or strength value to an object	<code>vpi_put_value()</code>

Table 36-8—VPI routines for simulation time processing

To	Use
Find the current simulation time or the scheduled time of future events	<code>vpi_get_time()</code>

Table 36-9—VPI routines for miscellaneous utilities

To	Use
Write to the output channel of the tool that invoked the PLI application and the current log file	<code>vpi_printf()</code>
Write to the output channel of the tool that invoked the PLI application and the current log file using varargs	<code>vpi_vprintf()</code>
Flush data from the current simulator output buffers	<code>vpi_flush()</code>
Open a file for writing	<code>vpi_mcd_open()</code>
Close one or more files	<code>vpi_mcd_close()</code>
Write to one or more files	<code>vpi_mcd_printf()</code>
Write to one or more open files using varargs	<code>vpi_mcd_vprintf()</code>
Flush data from a given <i>mcd</i> output buffer	<code>vpi_mcd_flush()</code>
Retrieve the name of an open file	<code>vpi_mcd_name()</code>
Retrieve data about tool invocation options	<code>vpi_get_vlog_info()</code>
See whether two handles refer to the same object	<code>vpi_compare_objects()</code>
Obtain error status and error information about the previous call to a VPI routine	<code>vpi_chk_error()</code>
Add application-allocated storage to application saved data	<code>vpi_put_data()</code>
Retrieve application-allocated storage from application saved data	<code>vpi_get_data()</code>
Store user data in VPI work area	<code>vpi_put_userdata()</code>
Retrieve user data from VPI work area	<code>vpi_get_userdata()</code>
Release handle and its associated resources allocated by VPI routines	<code>vpi_release_handle()</code>
Control simulation execution (e.g., stop, finish)	<code>vpi_control()</code>

36.12 VPI backwards compatibility features and limitations

The VPI data model has evolved over many previous versions in order to keep up with corresponding features of the Verilog language. Substantial efforts have been made to maintain backwards-compatibility with prior versions whenever possible. However, some critical incompatible changes were needed that could not be avoided. This subclause identifies those incompatibilities and provides a way for older affected applications to continue to run in newer VPI environments, with some important restrictions.

36.12.1 VPI Incompatibilities with other standard versions

[Table 36-10](#) summarizes the VPI incompatibilities with prior IEEE standard versions.

Table 36-10—Summary of VPI incompatibilities across standard versions

Incompatibility	IEEE 1364			IEEE 1800	
	1995	2001	2005	2005	2009
See detailed descriptions below					
1) vpiMemory exists as an object	Y	D	N	N	N
2) vpiMemoryWord exists as an object	Y	D	N	N	N
3) vpiIntegerVar and vpiTimeVar can be arrays	Y	Y	Y	N	N
4) vpiRealVar can be an array	N	Y	Y	N	N
5) vpiVariables iterations include vpiReg and vpiRegArray	N	N	N	Y	Y
6) vpiReg iterations on vpiRegArray include other objects	N	N	N	Y	Y
7) vpiRegArray iterations include variable arrays	N	N	N	Y	Y

Table Key:

- Y = Behavior, function or object present in that version
- D = Behavior, function or object deprecated (present, but use discouraged) in that version
- N = Behavior, function or object not applicable or no longer present in that version

For the above table and details below, the types **vpiReg** and **vpiRegArray** are the same as **vpiLogicVar** and **vpiArrayVar**, respectively, as shown in the IEEE 1800 VPI data model (see [37.16](#), detail [19](#)).

Incompatibility Details:

1) **vpiMemory** exists as an object:

Unpacked unidimensional **reg** arrays were exclusively characterized as **vpiMemory** objects in IEEE Std 1364-1995, and later deprecated in IEEE Std 1364-2001. This object type was replaced by **vpiRegArray** in IEEE Std 1364-2005, leaving **vpiMemory** allowed as only a one-to-many transition for IEEE Std 1364-2005 and IEEE Std 1800 standard versions (see [37.19](#)). IEEE Std 1364-2001 allowed either **vpiMemory** or **vpiRegArray** types to represent unpacked unidimensional arrays of **vpiReg** objects.

2) **vpiMemoryWord** exists as an object:

Elements of unpacked unidimensional **reg** arrays were exclusively characterized as **vpiMemoryWord** objects in IEEE Std 1364-1995, and later deprecated in IEEE Std 1364-2001. This object type was replaced by **vpiReg** in IEEE Std 1364-2005, leaving **vpiMemoryWord** allowed only as an iterator for IEEE Std 1364-2005 and IEEE Std 1800 standard versions (see [37.19](#)). IEEE Std 1364-2001 allowed either **vpiMemoryWord** or **vpiReg** types to represent elements of unpacked unidimensional arrays of **vpiReg** objects.

3) **vpiIntegerVar** and **vpiTimeVar** can be arrays

vpiIntegerVar and **vpiTimeVar** objects could represent unpacked arrays instead of simple variables in all IEEE 1364 standards. In IEEE Std 1800 standard versions, these array types are always represented as

vpiRegArray objects, and **vpiIntegerVar** and **vpiTimeVar** objects are always non-array variables (see [37.16](#)).

4) **vpiRealVar** can be an array

This object type was allowed to represent an unpacked array of such variables in IEEE Std 1364-2001 and IEEE Std 1364-2005 (**vpiRealVar** arrays were not yet allowed in IEEE Std 1364-1995). In IEEE Std 1800 standard versions, these are now exclusively represented as **vpiRegArray** objects (see [37.16](#)).

5) **vpiVariables** iterations include **vpiReg** and **vpiRegArray**

In all IEEE 1364 standards, **vpiReg** and **vpiRegArray** objects were excluded from **vpiVariables** iterations, and only accessed instead by iterations on **vpiReg** (from a scope or **vpiRegArray**), or **vpiRegArray** (from a scope), respectively. In IEEE Std 1800, they are both included in **vpiVariables** iterations (see [37.16](#)).

6) **vpiReg** iterations on **vpiRegArray** include other objects

This is a consequence of **vpiRegArray** objects being used to represent unpacked arrays of non-**vpiReg** elements in the IEEE 1800 standards (see [37.16](#)). **vpiReg** iterations on these array objects can retrieve array elements that are of type **vpiIntegerVar** or **vpiTimeVar** for example, which is not expected in IEEE Std 1364- 2001 and IEEE Std 1364-2005.

7) **vpiRegArray** iterations include variable array objects

This is another consequence of **vpiRegArray** objects being used to represent unpacked arrays of non-**vpiReg** elements in IEEE 1800 standards (see [37.16](#)). In IEEE Std 1364-2001 and IEEE Std 1364-2005, **vpiRegArray** iterations only included arrays of **vpiReg** objects, but, in IEEE 1800 standards, this iteration includes arrays of **vpiIntegerVar**, **vpiTimeVar**, and **vpiRealVar**.

36.12.2 VPI Mechanisms to deal with incompatibilities

In order to ease the transition to the latest VPI standard for older applications, capability shall be provided to emulate the incompatible VPI behaviors where they conflict with the current standard. This allows older VPI applications dependent on these behaviors to be run unmodified, as long as they are applied only to designs (or portions of designs) with which they are compatible. This capability is intended only as an interim measure to allow extra time for applications to be upgraded; it does not provide general emulation of older behaviors for newer design constructs. For example, it does not allow IEEE 1364 applications to run on portions of designs requiring IEEE 1800-level simulation capability.

As described in [36.12.2.1](#) and [36.12.2.2](#) below, two mechanisms to support this shall be provided, which can be used in combination.

36.12.2.1 Mechanism 1: Compile-based binding to a compatibility mode

This mechanism requires recompilation of the VPI application source code, and is based on defining a compiler symbol that binds a particular application to a particular compatibility mode. To use this scheme, one of the following compiler symbols shall be defined prior to compilation of any of the standard VPI include files in the application source code- either using a “#define” in the source code itself (setting it to the numeric constant “1”), or defined on the C-compiler command-line:

```
VPI_COMPATIBILITY_VERSION_1364v1995  
VPI_COMPATIBILITY_VERSION_1364v2001  
VPI_COMPATIBILITY_VERSION_1364v2005
```

```
VPI_COMPATIBILITY_VERSION_1800v2005  
VPI_COMPATIBILITY_VERSION_1800v2009
```

No more than one of these symbols shall be defined for a given application, and it shall be consistently defined for all of its source code that can access any portion of VPI, including callback functions. This allows all design information to be handled in the same way for a given mode across the entire application. A compilation error will occur during the processing of `vpi_user.h` if more than one of the above symbols is defined.

Example:

VPI source code file with a compatibility mode selected:

```
/* VPI application mytask */  
#include <stdio.h>  
#include <stdlib.h>  
#include <string.h>  
#define VPI_COMPATIBILITY_VERSION_1364v2001 1  
#include "vpi_user.h"  
#include "sv_vpi_user.h"  
#include "my_appl_header.h"  
...  
...
```

Alternatively, the same mode selection could be performed by defining the following option on the C-compiler command line:

```
-DVPI_COMPATIBILITY_VERSION_1364v2001
```

When a mode is selected by one of the means above, C-preprocessor constructs in `vpi_user.h` cause the following VPI functions to be redefined to mode-specific versions:

```
vpi_compare_objects  
vpi_control  
vpi_get  
vpi_get_str  
vpi_get_value  
vpi_handle  
vpi_handle_by_index  
vpi_handle_by_multi_index  
vpi_handle_by_name  
vpi_handle_multi  
vpi_iterate  
vpi_put_value  
vpi_register_cb  
vpi_scan
```

For example, defining the mode symbol ‘`VPI_COMPATIBILITY_VERSION_1364v2001`’ as shown above will cause ‘`vpi_handle`’ to be redefined as:

```
vpi_handle_1364v2001
```

This retargets all calls to ‘`vpi_handle`’ in the recompiled application to this mode-specific variant, achieving mode-compatible behavior. See “`vpi_compatibility.h`” ([Annex L](#)) for the complete set of definitions.

36.12.2.2 Mechanism 2: Selection of default VPI compatibility mode run by host simulator

A means to set the default VPI compatibility mode shall be made available by the simulation provider. This shall determine the compatibility mode VPI behavior for all applications not using the compile-based scheme detailed in mechanism #1. Although VPI applications choosing this mechanism can be run without modification or recompilation, only one such default mode shall be selectable for a given simulation run. Additional applications requiring different modes in the same run-time simulation environment shall use the compile-based mechanism to do so.

36.12.3 Limitations of VPI compatibility mechanisms

When a VPI application uses the compatibility mode mechanism, the application user and application provider should verify that the design or design partition to which the application is applied is consistent with the mode, and does not include constructs that are only supported in other modes. If the design contains unsupported constructs, the behavior of the VPI implementation is undefined. The extent of checking for consistency between constructs and mode is left to the discretion of the VPI implementation.

In general, VPI users and application developers are strongly encouraged to update their applications to the latest VPI version as soon as possible. The compatibility mode feature should be used only as a temporary solution until such upgrades can be completed or become available. It should be expected that older modes will be phased out as new versions of the standard become available.

37. VPI object model diagrams

37.1 General

This clause describes the following:

- Using VPI data models
- VPI data model diagrams

37.2 VPI Handles

A handle is an opaque reference to an object in the VPI information model. It is represented as a value of the data type `vpiHandle` (see [Annex K](#)); however, the interpretation of the representation is implementation defined. A handle allows a VPI program to refer to an object without assuming details of the representation of the object. The VPI provides functions that operate on objects referred to by handles. The particular operations that are legal for an object referred to by a handle depend on the type of the object.

37.2.1 Handle creation

A handle is created by a tool as the result of one of the following functions called by a VPI application program:

- a) **`vpi_handle()`**, which returns a handle that refers to an object in a one-to-one relationship
- b) **`vpi_handle_by_index()`**, which returns a handle that refers to an object in an ordered, one-to-many relationship using an index
- c) **`vpi_handle_by_multi_index()`**, which returns a handle that refers to an indexed subobject of a multidimensional parent object using an array of indices
- d) **`vpi_handle_by_name()`**, which returns a handle that refers to an object identified by a specific name
- e) **`vpi_handle_multi()`**, which returns a handle to an object in a many-to-one relationship
- f) **`vpi_iterate()`**, which returns a handle to an iterator object for scanning a one-to-many relationship
- g) **`vpi_put_value()`**, which returns a handle to a scheduled event object
- h) **`vpi_register_cb()`**, which returns a handle to the callback object being registered.
- i) **`vpi_register_systf()`**, which returns a handle to the callback object for a user-defined system task or function
- j) **`vpi_scan()`**, which returns a handle to objects in a one-to-many relationship, using their iterator object

A tool shall support multiple VPI programs, each of which acquires handles. The way in which a tool implements handles shall allow a VPI program to function correctly independently of other VPI programs executing concurrently. A tool may share between VPI programs resources associated with the implementation of handles and the objects to which they refer. However, the occurrence of such sharing shall not alter the effect of the VPI programs. If a tool creates two handles that refer to the same object, the tool may create two distinct handles or may provide the same handle in both cases. Two distinct handles that refer to the same object are equivalent.

NOTE—The number of handles that an implementation can create may be constrained by the capacity of the host system.

37.2.2 Handle release

The function **`vpi_release_handle()`** called by a VPI program causes a tool to release a handle. If a tool shares resources associated with handles and one VPI program releases a handle, other VPI programs shall

be able to continue to refer to objects using handles that they have not released. The tool may reclaim resources associated with the representation of a released handle. Handles may also be released as part of the action of other VPI function calls, in particular:

- a) **vpi_remove_callback()** releases the associated callback handle
- b) **vpi_scan()** releases the iterator handle after its last object has been scanned

Simulation events or actions may also cause certain handles to be released, in particular:

- 1) A simulation restart shall release all handles except for **cbStartOfRestart** and **cbEndOfRestart** callback handles.
- 2) Whenever the simulator frees objects belonging to a frame or thread, it shall release all handles to those objects, and to any subelement of these objects. Handles to callbacks placed on these objects will also be released.
- 3) Whenever the simulator reclaims the memory of a class object, it shall release all handles to the class object, to any of its automatic data members, and to any subelement of its automatic data members. Handles to callbacks placed on these objects will also be released.

NOTE 1—It is recommended that a VPI program release handles when they are no longer needed.

NOTE 2—A tool may reclaim resources associated with a handle when the handle is released by a VPI program, provided the requirements of [37.2](#) are met. As a consequence, resources might not be reclaimed immediately upon release of a handle by a VPI program, as the resources may be associated with handles in use by other VPI programs.

NOTE 3—A static local variable declared in a task/function does not belong to a frame or thread and handles to such a variable or callbacks associated with the variable are not released automatically when the frame or thread ends.

37.2.3 Handle comparison

Handle equivalence cannot be determined with a C ‘==’ comparison. The function **vpi_compare_objects()** compares the objects they refer to. It returns the value 1 if the objects they refer to are the same object); otherwise it returns the value 0. See [38.3](#).

37.2.4 Validity of handles

The *lifetime* of an object is the duration of existence of the object in the VPI information model. Lifetime of objects is discussed in [37.3.7](#). A tool can create a handle that refers to an object only during the lifetime of the object. A handle is said to be *valid* from the time of its creation until the time at which it is released, or until the object that it refers to ceases to exist, or until termination of the tool; at other times it is *invalid*. A VPI program shall not refer to an object using an invalid handle, nor shall a VPI program attempt to release an invalid handle.

37.3 VPI object classifications

VPI objects are classified using data model diagrams. These diagrams provide a graphical representation of those objects within a SystemVerilog design to which the VPI routines shall provide access. The diagrams shall show the relationships between objects and the properties of each object. Objects with sufficient commonality are placed in groups. Group relationships and properties apply to all the objects in the group.

As an example, the simplified diagram in [Figure 37-1](#) shows that there is a one-to-many relationship from objects of type **module** to objects of type **net** and a one-to-one relationship from objects of type **net** to objects of type **module**. Objects of type **net** have properties **vpiName**, **vpiVector**, and **vpiSize** with data types string, Boolean, and integer, respectively.

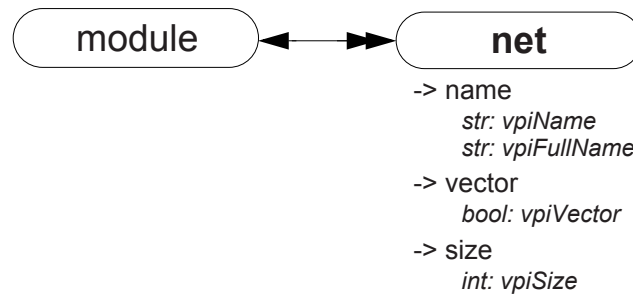

Figure 37-1—Example of object relationships diagram

For object relationships (unless a special tag is shown in the diagram), the type used for access is determined by adding “vpi” to the beginning of the word within the enclosure with each word’s first letter being a capital. Using the above example, if an application has a handle to a net and wants to go to the module instance where the net is defined, the call would be as follows:

```
modH = vpi_handle(vpiModule, netH);
```

where `netH` is a handle to the net. As another example, to access a “named event” object, use the type `vpiNamedEvent`.

37.3.1 Accessing object relationships and properties

VPI defines the C data type of `vpiHandle`. All objects are manipulated via a `vpiHandle` variable. Object handles can be accessed from a relationship with another object or from a hierarchical name as the following example demonstrates:

```
vpiHandle net;
net = vpi_handle_by_name("top.m1.w1", NULL);
```

This example call retrieves a handle to wire `top.m1.w1` and assigns it to the `vpiHandle` variable `net`. The `NULL` second argument directs the routine to search for the name from the top level of the design.

VPI provides generic functions for tasks, such as traversing relationships and determining property values. One-to-one relationships are traversed with routine `vpi_handle()`. In the following example, the module that contains `net` is derived from a handle to that net:

```
vpiHandle net, mod;
net = vpi_handle_by_name("top.m1.w1", NULL);
mod = vpi_handle(vpiModule, net);
```

The call to `vpi_handle()` in the above example shall return a handle to module `top.m1`.

Sometimes it is necessary to access a class of objects that do not have a name or whose name is ambiguous with another class of objects that can be accessed from the reference handle. *Tags* are used in this situation, as shown in [Figure 37-2](#).

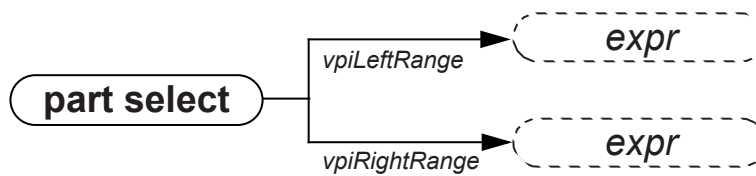

Figure 37-2—Accessing a class of objects using tags

In this example, the tags **vpiLeftRange** and **vpiRightRange** are used to access the expressions that make up the range of the part-select. These tags are used instead of **vpiExpr** to get to the expressions. Without the tags, VPI would not know which expression should be accessed. For example:

```
vpi_handle(vpiExpr, part_select_handle)
```

would be illegal when the reference handle (`part_select_handle`) is a handle to a part-select because the part-select can refer to two expressions, a left-range and a right-range.

Properties of objects shall be derived with routines in the *vpi_get* family. The routine **vpi_get()** returns integer and Boolean properties. Integer and Boolean properties shall be defined to be of type `PLI_INT32`. For Boolean properties, a value of 1 shall represent `TRUE` and a value of 0 shall represent `FALSE`. The routine **vpi_get64()** returns 64 bit integer properties as type `PLI_INT64`. The routine **vpi_get_str()** accesses string properties. String properties shall be defined to be of type `PLI_BYTE8 *`. For example, to retrieve a pointer to the full hierarchical name of the object referenced by handle `mod`, the following call would be made:

```
PLI_BYTE8 *name = vpi_get_str(vpiFullName, mod);
```

In the above example, the pointer `name` shall now point to the string “`top.m1`”.

One-to-many relationships are traversed with an iteration mechanism. The routine **vpi_iterate()** creates an object of type **vpiIterator**, which is then passed to the routine **vpi_scan()** to traverse the desired objects. In the following example, each net in module `top.m1` is displayed:

```
vpiHandle itr;
itr = vpi_iterate(vpiNet, mod);
while (net = vpi_scan(itr) )
    vpi_printf("\t%s\n", vpi_get_str(vpiFullName, net) );
```

As the above examples illustrate, the routine naming convention is a ‘vpi’ prefix with ‘_’ word delimiters (with the exception of callback-related defined values, which use the ‘cb’ prefix). Macro-defined types and properties have the ‘vpi’ prefix, and they use capitalization for word delimiters.

The routines for traversing SystemVerilog structures and accessing objects are described in [Clause 38](#).

37.3.2 Object type properties

All objects have a **vpiType** property, which is not shown in the data model diagrams.

```
-> type
    int: vpiType
```

Using `vpi_get(vpiType, <object_handle>)` returns an integer constant that represents the type of the object.

Using `vpi_get_str(vpiType, <object_handle>)` returns a pointer to a string containing the name of the type constant. The name of the type constant is derived from the name of the object as it is shown in the data model diagram (see [37.3](#) for a description of how type constant names are derived from object names).

Some objects have additional type properties that are shown in the data model diagrams: **vpiDelayType**, **vpiNetType**, **vpiOpType**, **vpiPrimType**, **vpiResolvedNetType**, and **vpiTchkType**. Using `vpi_get(<type_property>, <object_handle>)` returns an integer constant that represents the additional type of the object. See `vpi_user.h` in [Annex K](#) and `sv_vpi_user.h` in [Annex M](#) for the types that can be returned for these additional type properties. The constant names of the types returned for these additional type properties can be accessed using `vpi_get_str()`.

37.3.3 Object file and line properties

Most objects have the following two location properties, which are not shown in the data model diagrams:

-> location
int: vpiLineNo
str: vpiFile

The properties **vpiLineNo** and **vpiFile** can be affected by the `\line` compiler directive. See [22.12](#) for more details on the `\line` compiler directive. These properties are applicable to every object that corresponds to some object within the source code. The exceptions are objects of the following types:

- vpiCallback
- vpiDelayTerm
- vpiDelayDevice
- vpiInterModPath
- vpiIterator
- vpiTimeQueue
- vpiGenScopeArray
- vpiGenScope

37.3.4 Delays and values

Most properties are of type integer, Boolean, or string. Delay and logic value properties, however, are more complex and require specialized routines and associated structures. The routines `vpi_get_delays()` and `vpi_put_delays()` use structure pointers, where the structure contains the pertinent information about delays. Similarly, simulation values are also handled with the routines `vpi_get_value()` and `vpi_put_value()`, along with an associated set of structures.

The routines, C structures, and some examples for handling delays and logic values are presented in [Clause 38](#). See [38.15](#) for `vpi_get_value()`, [38.34](#) for `vpi_put_value()`, [38.10](#) for `vpi_get_delays()`, and [38.32](#) for `vpi_put_delays()`.

Nets, primitives, module paths, timing checks, and continuous assignments can have delays specified within the SystemVerilog source code. Additional delays may exist, such as module input port delays or inter-module path delays, that do not appear within the SystemVerilog source code. To access the delay expressions that are specified within the SystemVerilog source code, use the method **vpiDelay**. These expressions shall be either an expression that evaluates to a constant if there is only one delay specified or an operation if there are more than one delay specified. If multiple delays are specified, then the operation's **vpiOpType** shall be **vpiListOp**. To access the actual delays being used by the tool, use the routine `vpi_get_delays()` on any of these objects.

37.3.5 Expressions with side effects

VPI gives applications access to arbitrarily complex expressions from the SystemVerilog source, either as arguments to system tasks or functions (see [36.4](#)) or by traversing the design hierarchy. Expressions may have side effects when evaluated; such expressions include:

- Assignment operators ([11.4.1](#)).
- Increment and decrement operators ([11.4.2](#)).
- Function calls, including built-in methods and system function calls, that change the state of the simulation other than via their return values.
- Expressions in which other expressions with side effects appear as operands, arguments, or index expressions.

Applying the function `vpi_get_value()` ([38.15](#)) to an expression with side effects shall fully evaluate the expression together with its side effects. However, it shall be an error for an application to ask for a VPI property or relation of an expression if the VPI implementation cannot determine the value or handle without also evaluating an expression with side effects. Since implementations may differ in their ability to determine whether an expression has side effects, this result may result in an error with some implementations but not with others. It shall be an error for an application to apply `vpi_put_value()` ([38.34](#)) to an object if any of its index expressions is an expression with side effects.

To provide the greatest flexibility for VPI applications, it is recommended that expressions with side effects not be used as index expressions or as arguments to system tasks or functions or to SystemVerilog function calls.

Example 1:

```
function string ename(my_enum_type e);
    static first_time = 1;
    begin
        if (first_time == 1) first_time = 0;
        ename = e.name();
    end
endfunction
...
foo = ename(e);
```

For most implementations, asking for the `vpiSize` property of the function call `ename(e)` shall be an error because the implementation cannot determine the size of the function call without evaluating it, and evaluating it may have the side effect of changing the value of `first_time`.

In the unusual case in which all the names of the enumeration type have the same length, an implementation could in principle determine the `vpiSize` by analyzing the function without evaluating it. However, this is not required by the standard, and an implementation may issue an error in this case as well.

Example 2:

```
j = my_array[i++];
k = my_array[--i];
```

It shall be an error for a VPI application to apply `vpi_put_value()` to either `my_array[i++]` or `my_array[--i]`, since both expressions have side effects.

37.3.6 Object protection properties

All objects have a **vpiIsProtected** property, which is not shown in the data model diagrams.

-> IsProtected

bool: vpiIsProtected

Using `vpi_get(vpiIsProtected, object_handle)` returns a Boolean constant that indicates whether the object represents code contained in a decryption envelope. The **vpiIsProtected** property shall be TRUE if the *object_handle* represents code that is protected; otherwise, it shall be FALSE. Unless otherwise specified, access to relationships and properties of a protected object shall be an error. Restrictions on access to complex properties are specified in the function reference descriptions for the corresponding VPI functions. Access to the **vpiType** property and the **vpiIsProtected** property of a protected object shall be permitted for all objects.

NOTE—Handles to protected objects can be returned through object relationships or by direct lookup using VPI functions that return handles.

37.3.7 Lifetimes of objects

The lifetime of an object is the duration of existence of the object in the VPI information model. A source code object comes into existence during analysis and persists, independent of elaboration and runtime, until the tool terminates. It has a lifetime that is independent of simulation. Static objects rooted in the static design hierarchy are alive from the point at which they are created during elaboration and for the entire simulation. Objects that may have a lifetime shorter than the duration of the simulation are called *transient* objects. Class objects and automatic variables are transient objects.

A class object (see [37.28](#)) is alive from the time it is created by a call to `new()` until the time its memory is reclaimed by the simulator's automatic memory management (see [8.27](#)); data members and methods that belong to the class object have the same object lifetime as the class object. An automatic variable that belongs to a frame (see [37.38](#)) has the same object lifetime as that of the frame, which is alive from the point of the call that establishes the stack frame until the stack frame is destroyed.

Other transient objects include the following:

- a) Threads (see [37.40](#)).
- b) Outdated and out of scope references made within a thread
- c) Iterators (objects of type **vpiIterator**), which are created by calls to **vpi_iterate()** (see [38.23](#)).
- d) A **vpiSchedEvent** created by **vpi_put_value()** (see [38.34](#))
- e) Callbacks (see [38.36](#)).

There are two properties relevant to understanding the lifetimes of objects. As a property of an object, **vpiAutomatic** is a Boolean property which, when false, means the object is static. When true, it means the object is non-static and may be an automatic variable or dynamic object. The property name **vpiAutomatic** and its interpretation reflects the keywords in the language, `static` and `automatic`, used to declare the object. Those keywords may be applied to the object declaration or to the scope of the object, the latter indicating the default for all objects of that scope. **vpiAutomatic** is also a property of an instance of a module, program, interface, or package, indicating the default lifetime for variables of any of its declared tasks/functions. **vpiAutomatic** is also a property of a class `defn` or class `typespec`, indicating the default lifetime for variables of any of its declared tasks/functions. Other exceptions to this general description of **vpiAutomatic** are noted in the object diagram details.

The property **vpiAllocScheme** indicates how an object's memory was allocated and thus supports understanding its lifetime. It is useful for determining whether and how to manage a transient object. It is an enumeration of three possible values: **vpiAutomaticScheme**, **vpiDynamicScheme**, and **vpiOtherScheme**.

vpiAutomaticScheme indicates the object is allocated as part of a frame or thread and has the lifetime of that frame or thread. **vpiDynamicScheme** indicates the object was allocated in dynamic memory and may be a class object or part thereof. For all other objects, **vpiAllocScheme** shall return **vpiOtherScheme**.

37.3.8 Managing transient objects

One may obtain a handle to an object during its lifetime and it remains valid only as long as the object exists. For a static object, one may therefore keep its handle indefinitely. For a transient object, one may release its handle after use or expect that handle to be released and become invalid when the object ceases to exist.





The life of a transient object may be tracked through various callbacks, depending on the specific type of object. The callbacks are described on the object model diagrams and/or the function reference for **vpi_register_cb()**, as appropriate. The relevant callbacks are as follows:

cbCreateObj, cbReclaimObj, cbStartofFrame, cbEndOfFrame, cbStartOfThread, cbEndOfThread, and cbEndOfObject.

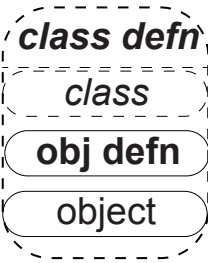

37.4 Key to data model diagrams

This subclause contains the keys to the symbols used in the data model diagrams. Keys are provided for objects and classes, traversing relationships, and accessing properties.

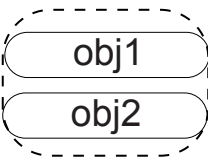
37.4.1 Diagram key for objects and classes

	<p>Object definition:</p> <p>Bold letters in a solid enclosure indicate an object definition. The properties of the object are defined in this location.</p>
	<p>Object reference:</p> <p>Normal letters in a solid enclosure indicate an object reference.</p>
	<p>Class definition:</p> <p><i>Bold italic</i> letters in a dotted enclosure indicate a class definition, where the class groups other objects and classes. Properties of the class are defined in this location. The class definition can contain an object definition.</p>
	<p>Class reference:</p> <p><i>Italic</i> letters in a dotted enclosure indicate a class reference.</p>
	<p>Unnamed class:</p> <p>A dotted enclosure with no name is an unnamed class. It is sometimes convenient to group objects although they shall not be referenced as a group elsewhere; therefore, a name is not indicated.</p>

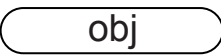
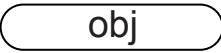
37.4.2 Diagram key for accessing properties

 <p>-> vector <i>bool: vpiVector</i></p> <p>-> size <i>int: vpiSize</i></p>	<p>Integer and Boolean properties are accessed with the routine vpi_get(). These properties are of type <code>PLI_INT32</code>.</p> <p>For example: Given handle <code>obj_h</code> to an object of type vpiObj, test if the object is a vector, and get the size of the object.</p> <pre>PLI_INT32 vect_flag = vpi_get(vpiVector, obj_h); PLI_INT32 size = vpi_get(vpiSize, obj_h);</pre>
 <p>-> name <i>str: vpiName</i> <i>str: vpiFullName</i></p>	<p>String properties are accessed with routine vpi_get_str(). String properties are of type <code>PLI_BYTE8 *</code>.</p> <p>For example:</p> <pre>PLI_BYTE8 *name = vpi_get_str(vpiName, obj_h);</pre>
 <p>-> complex <i>func1()</i> <i>func2()</i></p>	<p>Complex properties for time and logic value are accessed with the indicated routines. See the descriptions of the routines for usage.</p>

37.4.3 Diagram key for traversing relationships

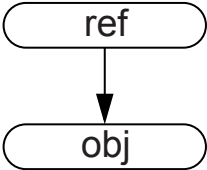
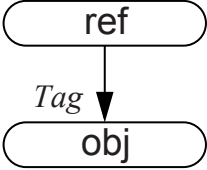
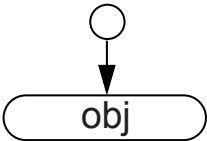
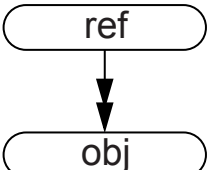
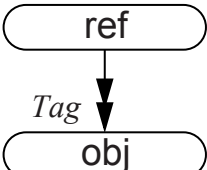
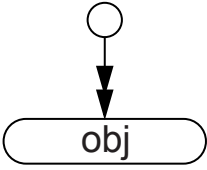
	<p>A single arrow indicates a one-to-one relationship accessed with the routine vpi_handle().</p> <p>For example: Given vpiHandle variable <i>ref_h</i> of type <i>ref</i>, access <i>obj_h</i> of type <i>Obj</i>:</p> <pre>obj_h = vpi_handle(Obj, ref_h);</pre>
	<p>A tagged one-to-one relationship is traversed similarly, using <i>Tag</i> instead of <i>Obj</i>.</p> <p>For example:</p> <pre>obj_h = vpi_handle(Tag, ref_h);</pre>
	<p>A one-to-one relationship which originates from a circle is traversed using NULL for the <i>ref_h</i>.</p> <p>For example:</p> <pre>obj_h = vpi_handle(Obj, NULL);</pre>
	<p>A double arrow indicates a one-to-many relationship accessed with the routine vpi_scan().</p> <p>For example: Given vpiHandle variable <i>ref_h</i> of type <i>ref</i>, scan objects of type <i>Obj</i>:</p> <pre>itr = vpi_iterate(Obj, ref_h); while (obj_h = vpi_scan(itr)) /* process 'obj_h' */</pre>
	<p>A tagged one-to-many relationship is traversed similarly, using <i>Tag</i> instead of <i>Obj</i>.</p> <p>For example:</p> <pre>itr = vpi_iterate(Tag, ref_h); while (obj_h = vpi_scan(itr)) /* process 'obj_h' */</pre>
	<p>A one-to-many relationship that originates from a circle is traversed using NULL for the <i>ref_h</i>.</p> <p>For example:</p> <pre>itr = vpi_iterate(Obj, NULL); while (obj_h = vpi_scan(itr)) /* process 'obj_h' */</pre>

For relationships that do not have a tag, the type used for access is determined by adding “vpi” to the beginning of the word within the enclosure with each word’s first letter being a capital. See [37.3](#) for more details on VPI access to constant names.

37.5 Module

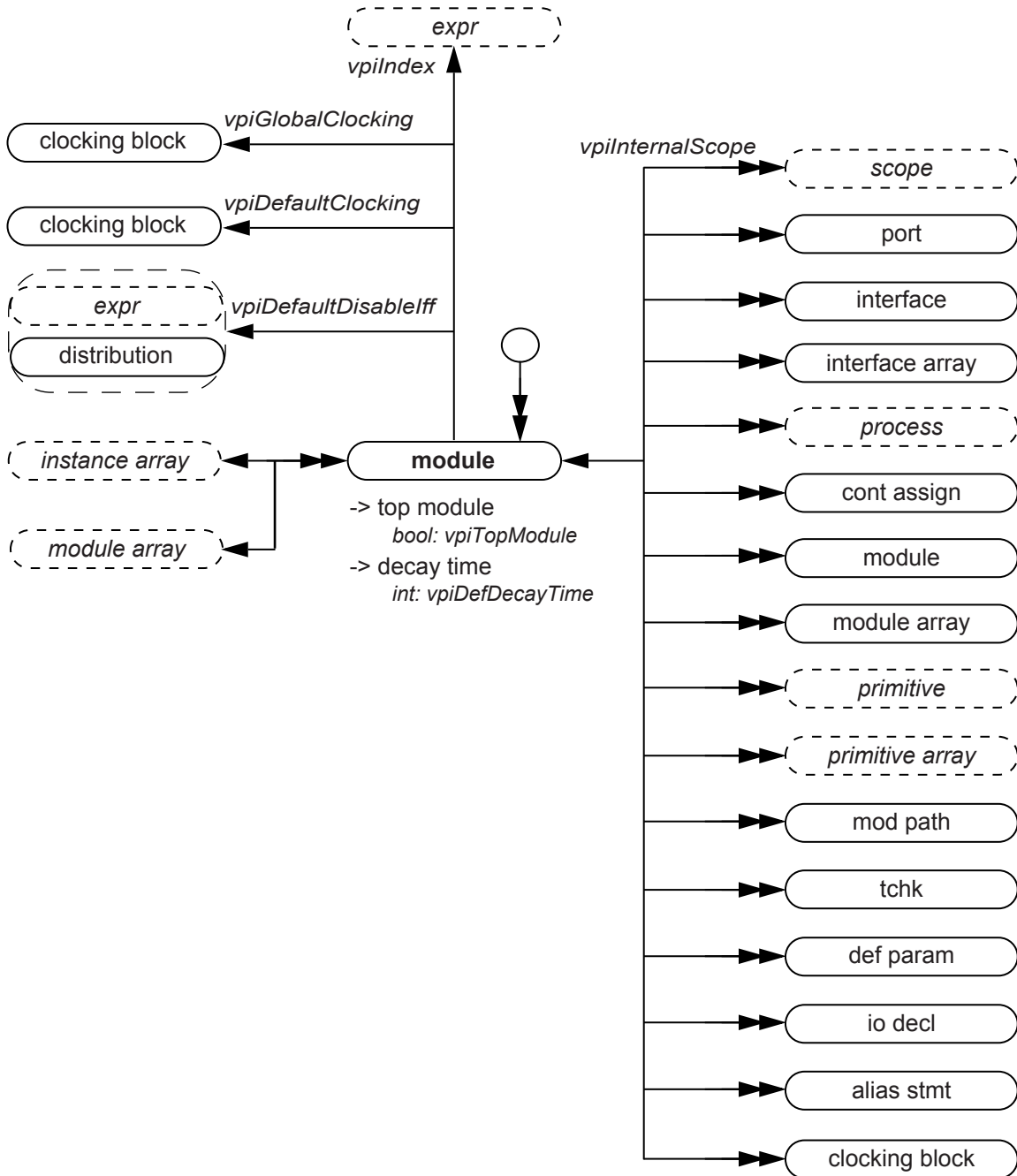

Details:

- 1) Top-level modules shall be accessed using **vpi_iterate()** with a NULL reference object.
- 2) If a module is an element within a module array, the **vpiIndex** transition is used to access the index within the array. If a module is not part of a module array, this transition shall return NULL.

37.6 Interface

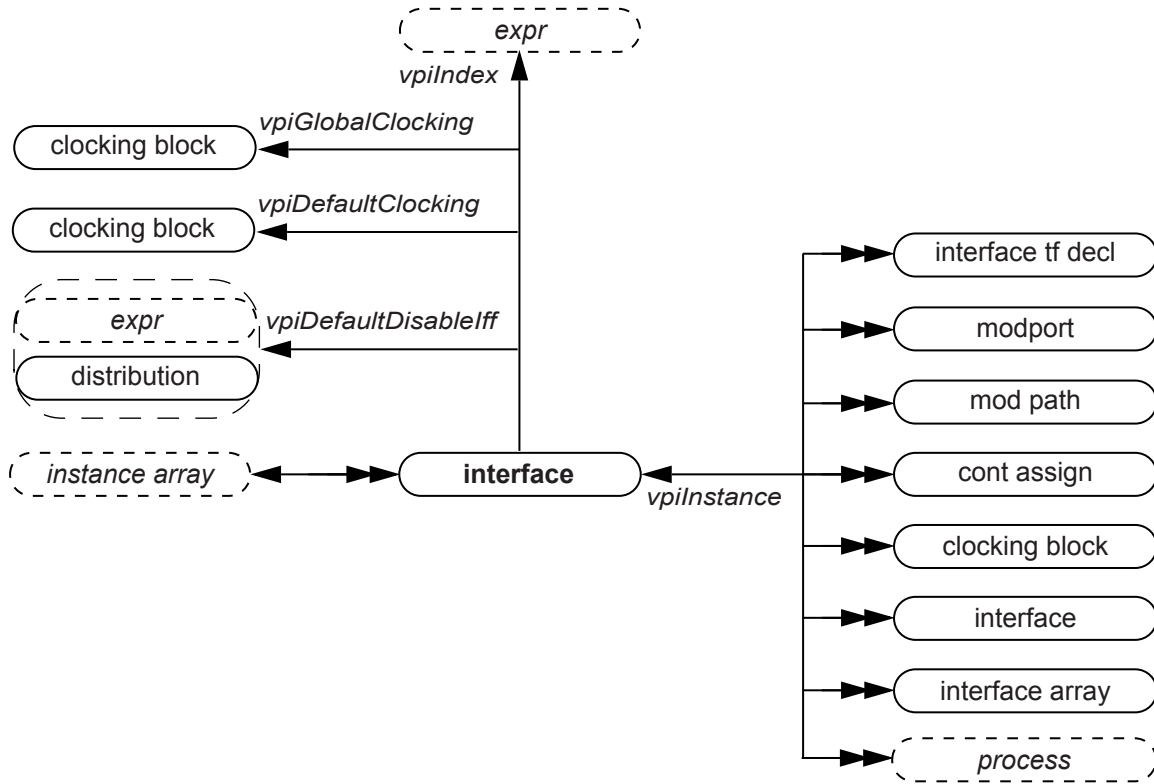

Details:

- 1) If an interface is an element within an instance array, the **vpiIndex** transition is used to access the index within the array. If an interface is not part of an instance array, this transition shall return NULL.

37.7 Modport

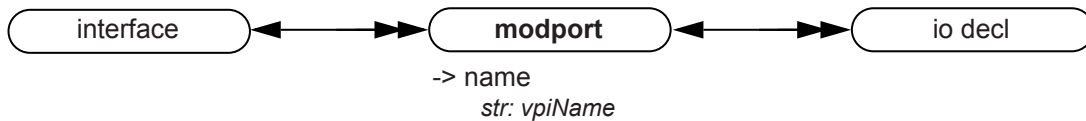

37.8 Interface task or function declaration

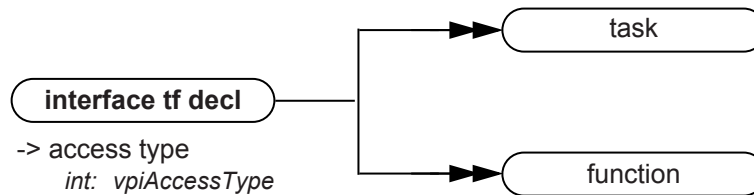

Details:

- 1) **vpi_iterate()** can return more than one task or function declaration for modport tasks or functions with an access type of **vpiForkJoin**, because the task or function can be imported from multiple module instances.
- 2) Possible return values for the **vpiAccessType** property for an interface tf decl are **vpiForkJoin** and **vpiExtern**.

37.9 Program

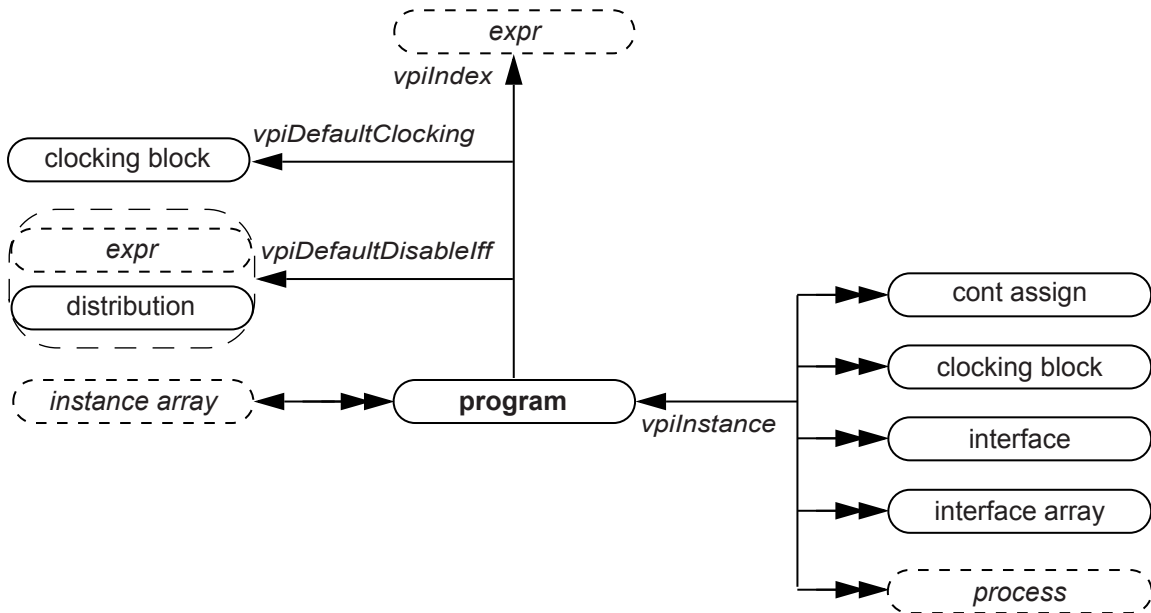

Details:

- 1) If a program is an element within an instance array, the **vpiIndex** transition is used to access the index within the array. If a program is not part of an instance array, this transition shall return NULL.

37.10 Instance

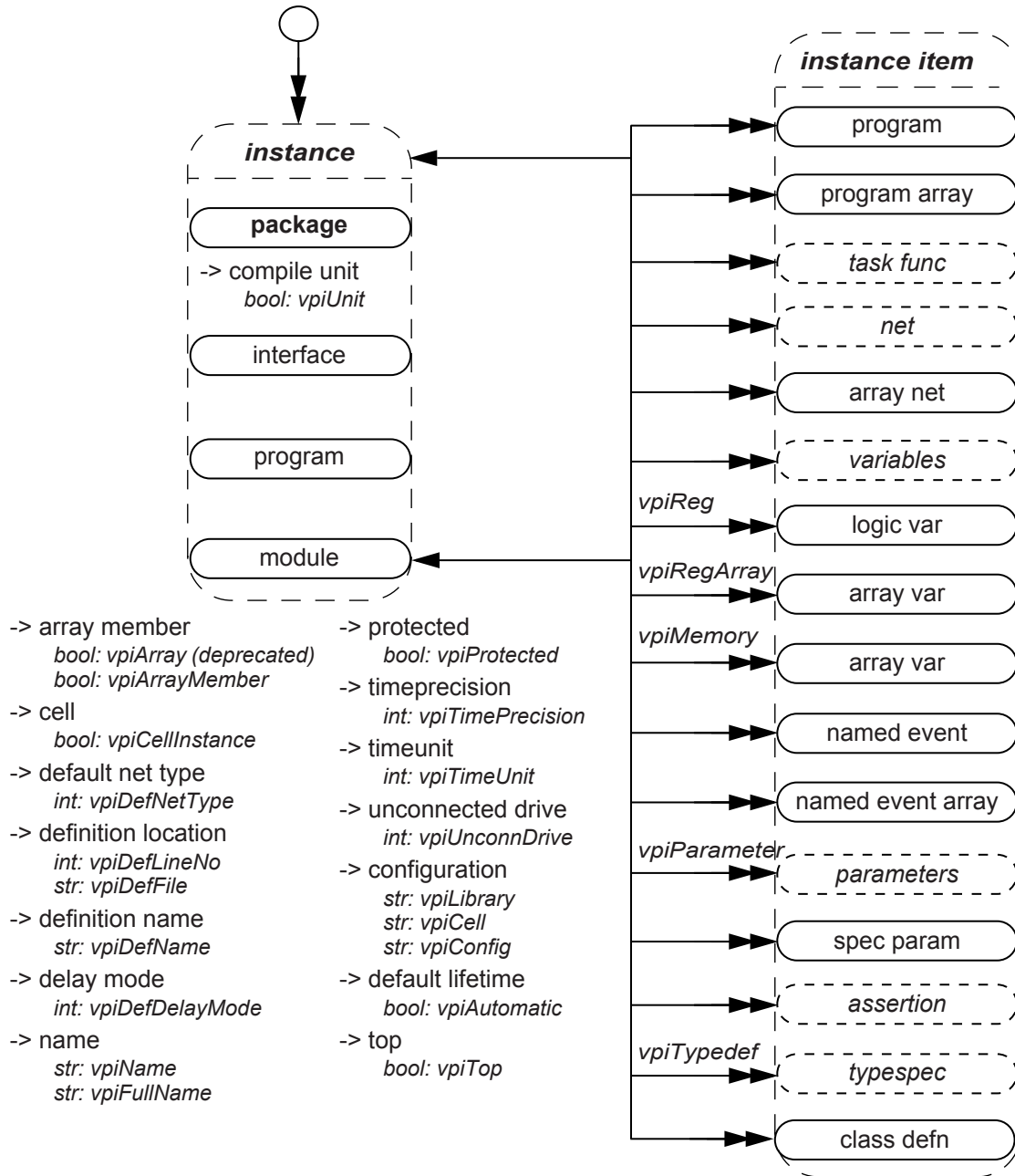

Details:

- 1) The **vpiTypedef** iteration shall return the user-defined typespecs that have typedefs explicitly declared in the instance.
- 2) **vpiModule** shall return a module if the object is inside a module instance, otherwise it shall return NULL.
- 3) **vpiInstance** shall always return the immediate instance (package, module, interface, or program) in which the object is instantiated.
- 4) **vpiMemory** shall return array variable objects rather than **vpiMemory** objects.

- 5) **vpiFullName** for objects that exist within a compilation unit shall begin with '\$unit::'. As a result, the full name for objects within a compilation unit may be ambiguous. **vpiFullName** for a package shall be the name of the package and should end with "::"; this syntax disambiguates between a module and a package of the same name. **vpiFullName** for objects that exist in a package shall begin with the name of the package followed by "::". The separator "::" shall appear between the package name and the immediately following name component. The "." separator shall be used in all cases except package and class defn.
- 6) The following items shall not be accessible via `vpi_handle_by_name()`:
 - imported items
 - objects that exist within a compilation unit
- 7) Passing a NULL handle to `vpi_get()` with properties **vpiTimePrecision** or **vpiTimeUnit** shall return the smallest time precision of all modules in the instantiated design.
- 8) The properties **vpiDefLineNo** and **vpiDefFile** can be affected by the ``line` compiler directive. See [22.12](#) for more details on the ``line` directive.
- 9) For details on lifetime and memory allocation properties, see [37.3.7](#).

37.11 Instance arrays

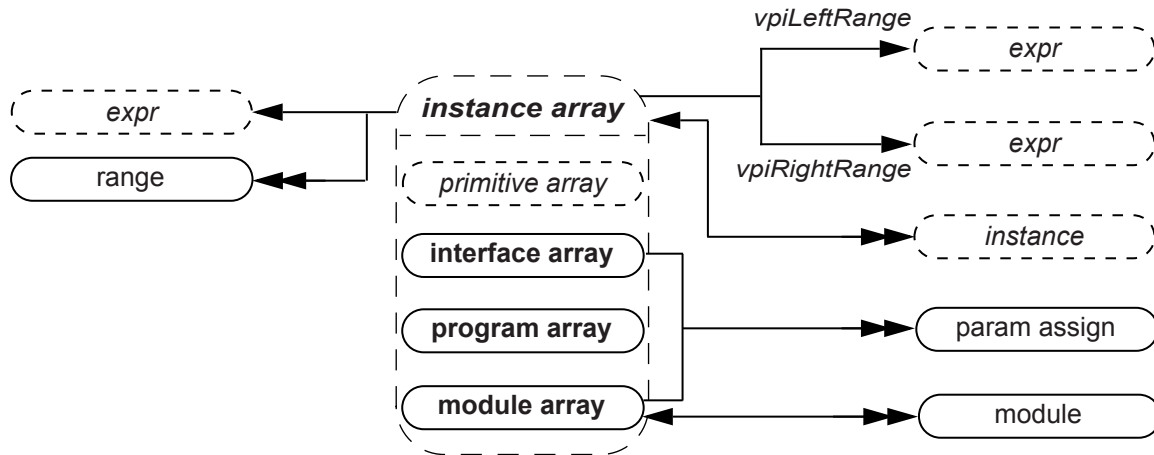

- > access by index
 - vpi_handle_by_index()*
 - vpi_handle_by_multi_index()*
- > name
 - str: vpiName*
 - str: vpiFullName*
- > size
 - int: vpiSize*

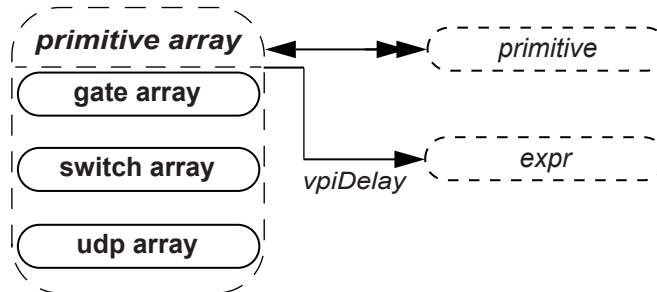

Details:

- 1) Traversing from the instance array to **expr** shall return a simple expression object of type **vpiOperation** with a **vpiOpType** of **vpiListOp**. This expression can be used to access the actual list of connections to the instance array in the SystemVerilog source code
- 2) **vpi_iterate(vpiRange, instance_array_handle)** shall return the set of instance array ranges beginning with the leftmost range of the array declaration and iterating through the rightmost range. Using the **vpiLeftRange/vpiRightRange** properties returns the bounds of the leftmost dimension of a multidimensional array.

37.12 Scope

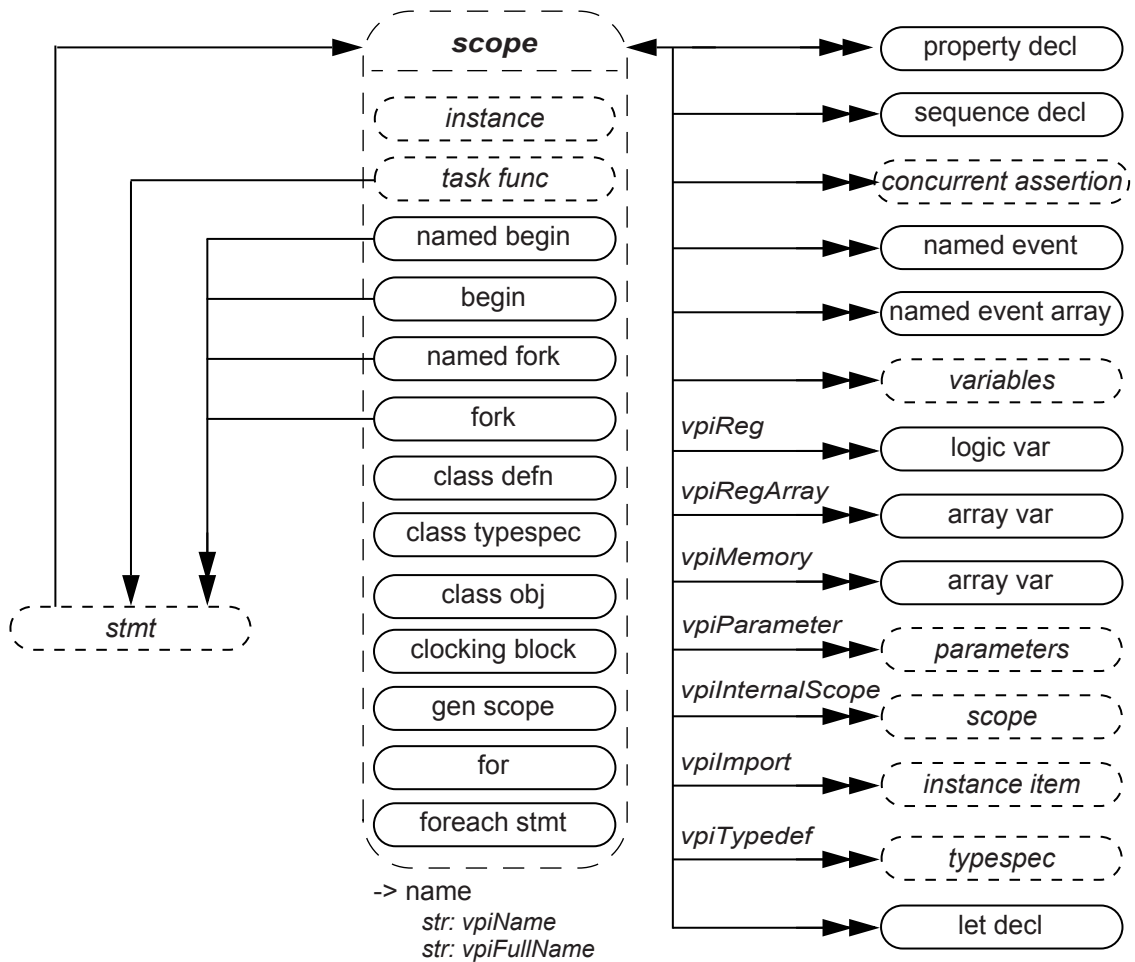

Details:

- 1) An unnamed begin or unnamed fork shall be a scope if and only if it directly contains a block item declaration such as a variable declaration or type declaration. A named begin or named fork shall always be a scope.

Example:

```
begin
  begin : BLK
    var logic v; // This declaration is not local to the unnamed begin
    v = 1'b1;
  end
end
```

In this example, the block BLK is a scope, but the unnamed begin is not a scope because it does not directly contain a block item declaration.

- 2) A for statement shall be a scope if and only if the **vpiLocalVarDecls** property returns TRUE. In this case, the scope of each loop control variable shall be the for statement.
- 3) The scope of each loop control variable in a foreach stmt shall be the foreach stmt.
- 4) The **vpiImport** iterator shall return all objects imported into the current scope via import declarations. Only objects actually referenced through the import shall be returned, rather than items potentially made visible as a result of the import. Refer to [26.3](#) for more details.

- 5) A task func can have zero or more statements (see [13.3](#) and [13.4](#)). If the number of statements is greater than 1, the **vpiStmt** relation shall return an unnamed **begin** that contains the statements of the task or function. If the number of statements is zero, the **vpiStmt** relation shall return NULL.

37.13 IO declaration

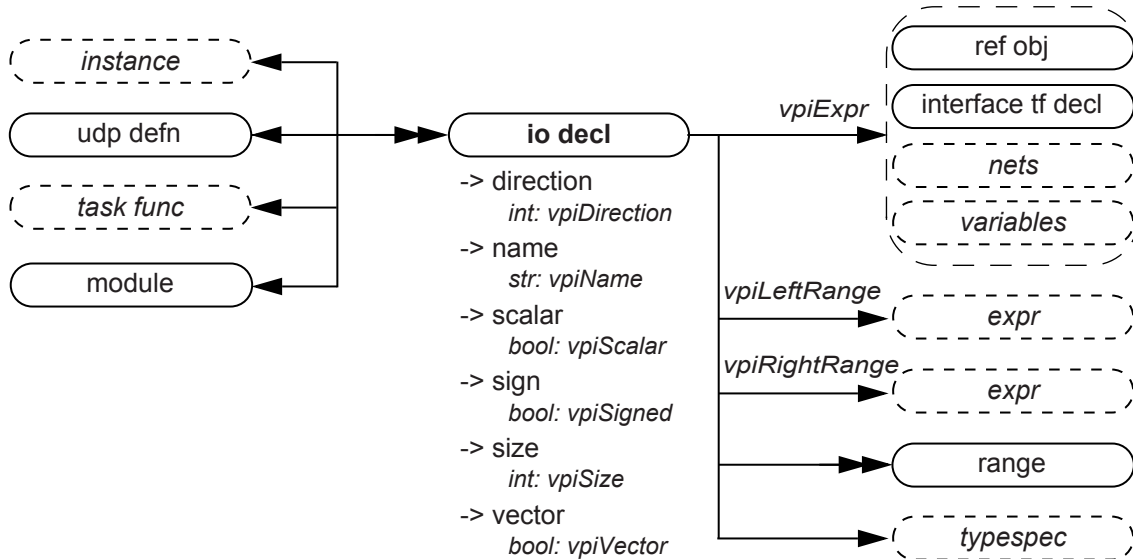

Details:

- 1) **vpiDirection** returns **vpiRef** for pass by **ref** ports or arguments.
- 2) A ref obj type handle may be returned for the **vpiExpr** of an io decl if it is passed by reference or if the io decl is an interface or a modport.
- 3) If the **vpiExpr** of an io decl is a ref obj and if the **vpiActual** of the ref obj is an interface or modport declaration, then the **vpiDirection** of the io decl shall be undefined.
- 4) The **vpiRange**, **vpiLeftRange**, and **vpiRightRange** relations for an io decl shall be the same as for the corresponding typespec (see [37.23](#)).

37.14 Ports

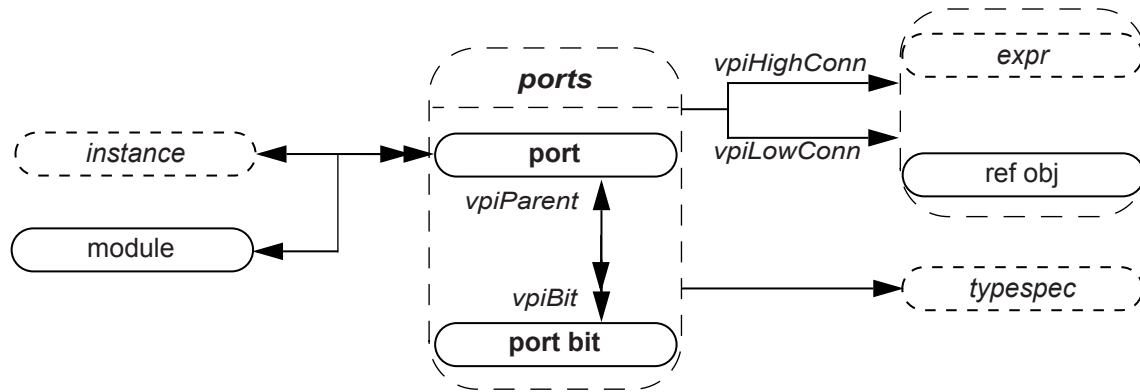

- | | |
|------------------------------------|--------------------------|
| -> access by index | -> index |
| <i>vpi_handle_by_index()</i> | <i>int: vpiPortIndex</i> |
| <i>vpi_handle_by_multi_index()</i> | -> name |
| -> connected by name | <i>str: vpiName</i> |
| <i>bool: vpiConnByName</i> | -> port type |
| -> delay (mipd) | <i>int: vpiPortType</i> |
| <i>vpi_get_delays()</i> | -> scalar |
| <i>vpi_put_delays()</i> | <i>bool: vpiScalar</i> |
| -> direction | -> size |
| <i>int: vpiDirection</i> | <i>int: vpiSize</i> |
| -> explicitly named | -> vector |
| <i>bool: vpiExplicitName</i> | <i>bool: vpiVector</i> |

Details:

- 1) **vpiPortType** shall be one of the following three types: **vpiPort**, **vpiInterfacePort**, and **vpiModportPort**. Port type depends on the formal, not on the actual.
- 2) **vpi_get_delays()**, **vpi_put_delays()** delays shall not be applicable for **vpiInterfacePort**.
- 3) **vpiHighConn** shall indicate the hierarchically higher (closer to the top module) port connection.
- 4) **vpiLowConn** shall indicate the lower (further from the top module) port connection.
- 5) **vpiLowConn** of a **vpiInterfacePort** shall always be **vpiRefObj**.
- 6) Properties **vpiScalar** and **vpiVector** shall indicate if the port is 1 bit or more than 1 bit. They shall not indicate anything about what is connected to the port.
- 7) Properties **vpiIndex** and **vpiName** shall not apply for port bits.
- 8) If a port is explicitly named, then the explicit name shall be returned. If not, and a name exists, then that name shall be returned. Otherwise, **NULL** shall be returned.
- 9) **vpiPortIndex** can be used to determine the port order. The first port has a port index of zero.
- 10) **vpiLowConn** shall return **NULL** if the module or interface or program port is a null port (e.g., “**module** **M**() ;”). **vpiHighConn** shall return **NULL** if the instance of the module, interface, or program does not have a connection to the port.
- 11) **vpiSize** for a null port shall return 0.

37.15 Reference objects

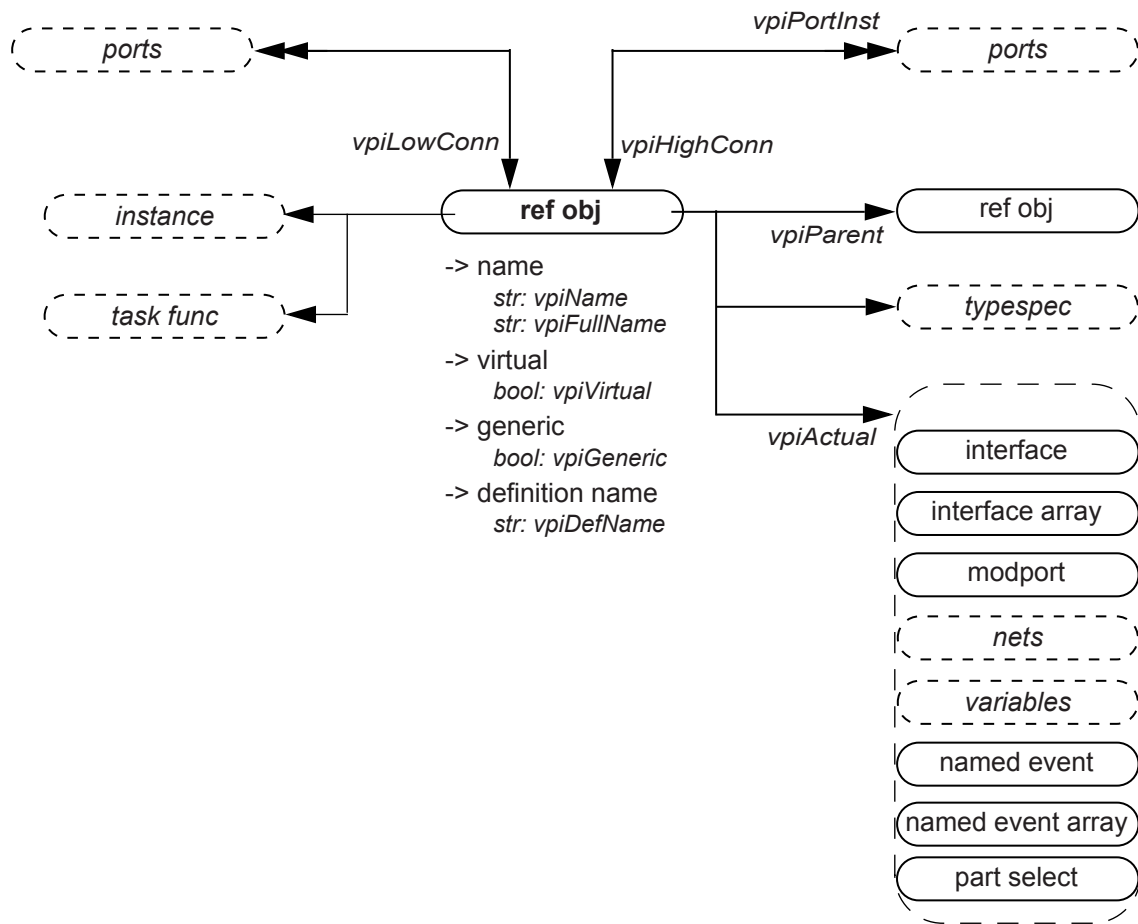

Details:

- 1) A ref obj represents a declared object or sub-element of that object that is a reference to an actual instantiated object. A ref obj exists for ports with **ref** direction, for an interface port, a modport port, or for formal task function ref arguments. The specific cases for a ref obj are:
 - A variable, named event, named event array that is the lowconn of a ref port
 - Any subelement expression of the above
 - A local declaration of an interface or modport passed through a port or any net, variable, named event, named event array of those
 - A virtual interface declaration in a class definition
 - A ref formal argument of a task or function, or sub-element expression of it
- 2) A ref obj may be obtained when walking port connections (lowConn, highConn), when traversing an expression that is a use of such ref obj, when accessing the virtual interface of a class, or when accessing the io decl of an instance or task or function.
- 3) The name of ref obj can be different at every instance level it is being declared. The **vpiActual** relationship always returns the actual instantiated object if the ref obj is bound to an actual object at the time of the query.
- 4) The **vpiParent** relationship allows the traversal of a ref obj which is a sub-element of a ref obj. In the example below, `r[0]` is a ref obj whose parent is the ref obj `r`. The **vpiActual** for the ref obj `r[0]` would return the var bit `a[0]` and the **vpiActual** of the ref obj `r` would return the variable `a`.

```
module top;
```

```

    logic [2:0] a;
    m u1 (a);
endmodule
module m (ref [2:0] r);
    initial
        r[0] = 1'b0;
endmodule

```

- 5) The **vpiVirtual** property shall return TRUE if the ref obj is a reference to a virtual interface and FALSE if the ref obj is a reference to an interface that is not a virtual interface. The **vpiVirtual** property shall return **vpiUndefined** for all other kinds of ref obj.
- 6) The **vpiGeneric** property shall return TRUE if the ref obj is a reference to a generic interface and FALSE if the ref obj is a reference to an interface that is not a generic interface. The **vpiGeneric** property shall return **vpiUndefined** for all other kinds of ref obj.
- 7) The **vpiDefName** property when applied to a ref obj that is an actual of an interface or modport shall return the interface definition name or modport name.
- 8) The **vpiTypeSpec** property returns NULL for a ref obj which **vpiActual** is a not a net, variable, or part select.

Example 1: Passing an interface or modport through a port:

```

interface simple ();
    logic req, gnt;
    modport slave (input req, output gnt);
    modport master (input gnt, output req);
endinterface

module top();

    interface simple i;

        child1 i1(i);
        child2 i2(i.master);
    endmodule

    /*****
    for the port of i1,
        the vpiHighConn relationship returns a handle of type vpiRefObj. The
        vpiActual relationship applied to the ref obj returns a handle of type
        vpiInterface.

    for the port of i2 ,
        the vpiHighConn relationship returns a handle of type vpiRefObj. The
        vpiActual relationship applied to the ref obj returns a handle of type
        vpiModport.
    *****/

    module child1(interface simple s);
        c1 c_1(s);
        c1 c_2(s.master);
    endmodule

    /*****
    for the port of module child1,
        the vpiLowConn relationship returns a handle of type vpiRefObj. The
        vpiActual relationship applied to the ref obj returns a handle of type
        vpiInterface.
    for that refObj,
        the vpiPort relationship returns the port of child1.
    *****/

```

```

    the vpiPortInst iteration returns handles to s, s.master.
    the vpiActual relationship returns a handle to i.
  for the port of instance c_1 :
    vpiHighConn returns a handle of type vpiRefObj. The vpiActual relationship
    applied to the ref obj handle returns a handle of type vpiInterface.
  for the port of instance c_2 :
    vpiHighConn returns a handle of type vpiRefObj. The vpiActual relationship
    applied to the ref obj handle returns a handle of type vpiModport.
  *****/

```

Example 2: virtual interface declaration in a class definition:

```

interface SBus; // A Simple bus interface
  logic req, grant;
  logic [7:0] addr, data;
endinterface

class SBusTransactor; // SBus transactor class
  virtual SBus bus; // virtual interface of type SBus
  function new( virtual SBus s );
    bus = s; // initialize the virtual interface
  endfunction
  task request(); // request the bus
    bus.req <= 1'b1;
  endtask
  task wait_for_bus(); // wait for the bus to be granted
    @(posedge bus.grant);
  endtask
endclass

module devA( Sbus s ); ... endmodule // devices that use SBus

module devB( Sbus s ); ... endmodule

module top;
  SBus s[1:4] (); // instantiate 4 interfaces
  devA a1( s[1] ); // instantiate 4 devices
  devB b1( s[2] );
  devA a2( s[3] );
  devB b2( s[4] );
  initial begin
    SbusTransactor t[1:4]; // create 4 bus-transactors and bind
    t[1] = new( s[1] );
    t[2] = new( s[2] );
    t[3] = new( s[3] );
    t[4] = new( s[4] );
  end
endmodule

```

A ref obj is returned for the left hand side expression of the statement “bus = s” in the constructor of the class definition SBusTransactor. The **vpiName** of that ref obj is “bus” and its **vpiDefName** is the name of the interface “SBus”. The **vpiActual** relationship returns the interface instance associated with that particular call to new after the assignment has executed. For example if it was “new (s[1])”, **vpiActual** would return the interface s[1]. If **vpiActual** is queried before the assignment is executed, the method may return NULL if the virtual “bus” interface is uninitialized. The right-hand side expression also returns a ref obj which **vpiActual** is the interface instance passed to the call to new.

37.16 Nets

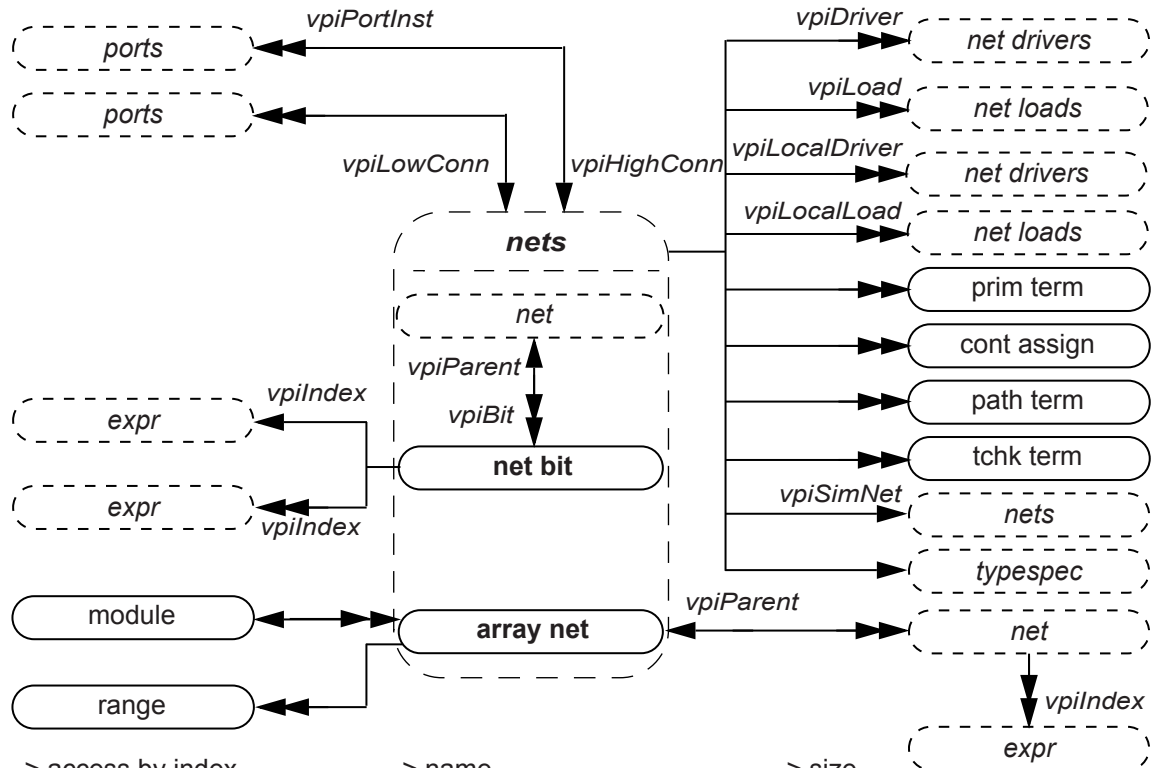

- > access by index
vpi_handle_by_index()
vpi_handle_by_multi_index()
- > array member
bool: vpiArray (deprecated)
bool: vpiArrayMember
- > constant selection
bool: vpiConstantSelect
- > delay
vpi_get_delays()
- > expanded
bool: vpiExpanded
- > implicitly declared
bool: vpiImplicitDecl

- > name
str: vpiName
str: vpiFullName
- > net decl assign
bool: vpiNetDeclAssign
- > net type
int: vpiNetType
int: vpiResolvedNetType
- > scalar
bool: vpiScalar
- > scalared declaration
bool: vpiExplicitScalared
- > sign
bool: vpiSigned

- > size
int: vpiSize
- > strength
int: vpiStrength0
int: vpiStrength1
int: vpiChargeStrength
- > value
vpi_get_value()
vpi_put_value()
- > vector
bool: vpiVector
- > vectored declaration
bool: vpiExplicitVectored
- > member
bool: vpiStructUnionMember

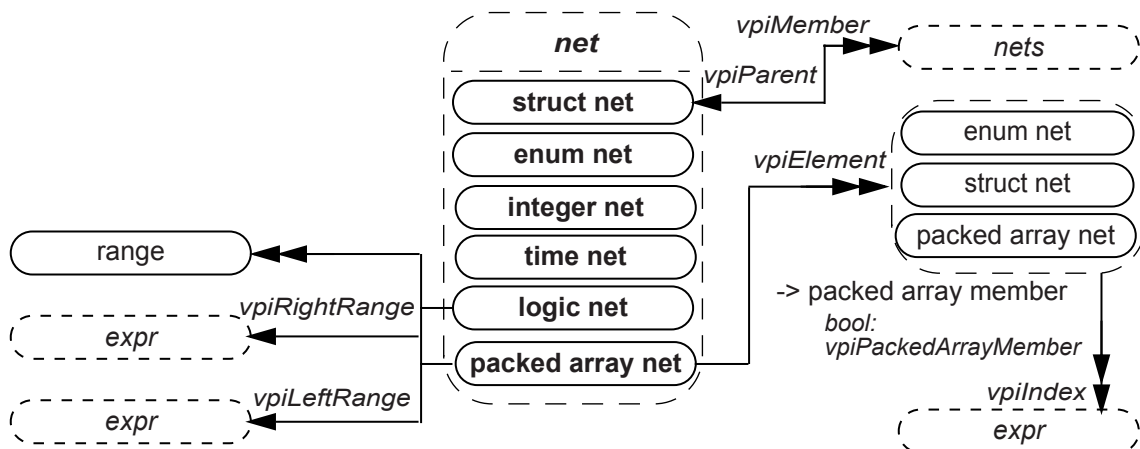

Details:

- 1) Any net declared as an array with one or more unpacked ranges is an array net. Any packed struct net or enum net declared with one or more explicit packed ranges is a packed array net. The range iterator for a packed array net returns only the explicit packed ranges for such a net. It shall not return the implicit range of packed struct net elements themselves, nor shall it return the range (explicit or implicit) for the base type of enum net elements. For example:

```
// a 34-bit-wide struct net (range iteration not allowed)
wire struct packed { logic [1:0]vec1; integer i1; } psnet;

// a packed array net (ranges [3:0] and [2:1] returned by range iteration)
wire struct packed { logic [1:0]vec1; integer i1; } [3:0][2:1] panet;

// an array net (ranges [5:4] and [6:8] returned by range iteration)
wire struct packed { logic [1:0]vec1; integer i1; } [3:0][2:1] anet
[5:4][6:8];
```

- 2) The Boolean property **vpiArray** is deprecated in this standard. The **vpiArrayMember** property shall be TRUE for a net that is an element of an array net. It shall be FALSE otherwise. The **vpiPackedArrayMember** property shall be TRUE for a packed struct net, an enum net, or a packed array net that is an element of a packed array net.
- 3) For logic nets, net bits shall be available regardless of vector expansion.
- 4) Continuous assignments and primitive terminals shall be accessed regardless of hierarchical boundaries.
- 5) Continuous assignments and primitive terminals shall only be accessed from scalar nets or bit-selects.
- 6) For **vpiPorts**, if the reference handle is a net bit, then port bits shall be returned. If it is an entire net or array net, then a handle to the entire port shall be returned.
- 7) For **vpiPortInst**, if the reference handle is a bit or scalar, then port bits or scalar ports shall be returned, unless the highconn for the port is a complex expression where the bit index cannot be determined. If this is the case, then the entire port shall be returned. If the reference handle is an entire net or array net, then the entire port shall be returned.
- 8) For **vpiPortInst**, it is possible for the reference handle to be part of the highconn expression, but not connected to any of the bits of the port. This may occur if there is a size mismatch. In this situation, the port shall not qualify as a member for that iteration.
- 9) For implicit nets, **vpiLineNo** shall return 0, and **vpiFile** shall return the file name where the implicit net is first referenced.
- 10) **vpi_handle(vpiIndex, net_bit_handle)** shall return the bit index for the net bit. **vpi_iterate(vpiIndex, net_bit_handle)** shall return the set of indices for a multidimensional net array bit-select, starting with the index for the net bit and working outward.
- 11) Only active forces and assign statements shall be returned for **vpiLoad**.
- 12) Only active forces shall be returned for **vpiDriver**.
- 13) **vpiDriver** shall also return ports that are driven by objects other than nets and net bits.
- 14) **vpiLocalLoad** and **vpiLocalDriver** return only the loads or drivers that are local, i.e.: contained by the module instance that contains the net, including any ports connected to the net (output and inout ports are loads, input and inout ports are drivers).
- 15) For **vpiLoad**, **vpiLocalLoad**, **vpiDriver** and **vpiLocalDriver** iterators, if the object is a vector net (an enum net, integer net, time net, packed array net, or a logic net or struct net for which **vpiVector** is TRUE), then all loads or drivers are returned exactly once as the loading or driving object. That is, if a part-select loads or drives only some bits, the load or driver returned is the part-select. If a driver is repeated, it is only returned once. To trace exact bit-by-bit connectivity pass a **vpiNetBit** object to **vpi_iterate**.
- 16) An iteration on loads or drivers for a variable bit-select shall return the set of loads or drivers for whatever bit to which the bit-select is referring to at the beginning of the iteration.
- 17) **vpiSimNet** shall return a unique net if an implementation collapses nets across hierarchy (refer to [23.3.3.7](#) for the definition of simulated net and collapsed net).
- 18) The property **vpiExpanded** on an object of type **vpiNetBit** shall return the property's value for the parent.

- 19) The loads and drivers returned from **(vpiLoad, obj_handle)** and **vpi_iterate(vpiDriver, obj_handle)** may not be the same in different implementations, due to allowable net collapsing [23.3.3.7](#). The loads and drivers returned from **vpi_iterate(vpiLocalLoad, obj_handle)** and **vpi_iterate(vpiLocalDriver, obj_handle)** shall be the same for all implementations.
- 20) The Boolean property **vpiConstantSelect** shall return `TRUE` for a net or net bit if it has no parent (the **vpiParent** relation returns `NULL`) or if both of the following are true of the “select” part of the equivalent primary expression (see [A.8.4](#)):
- Every index expression in the select is an elaboration time constant expression.
 - Every element within the select denotes either a member of a struct net or a member of a packed or unpacked array with static bounds.

Otherwise, **vpiConstantSelect** shall return `FALSE`.

NOTE—If **vpiConstantSelect** is `TRUE`, then if the handle refers to a valid underlying simulation object at the beginning of simulation (or at any point in the simulation), it refers to the same object at all points in the simulation. Moreover, if any index expression is in or out of bounds at the beginning of simulation, it is in or out of bounds at all subsequent simulation times as well.

- 21) **vpiSize** for an array net shall return the number of nets in the array. For unpacked structures, the size returned indicates the number of members in the structure. For an enum net, integer net, logic net, time net, packed struct net, or packed array net, **vpiSize** shall return the size of the net in bits. For a net bit, **vpiSize** shall return 1.
- 22) **vpi_iterate(vpiIndex, net_handle)** shall return the set of indices for a net within an array net, starting with the index for the net and working outward. If the net is not part of an array (the **vpiArrayMember** property is `FALSE`), a `NULL` shall be returned. The **vpiIndex** iterator shall work similarly for packed array net elements (packed struct nets, enum nets, or packed array nets whose **vpiPackedArrayMember** property is `TRUE`). The indices returned shall start with the index of the element and work outward until the **vpiParent** packed array net is reached (see detail [28](#)). The indices retrieved for packed array net elements shall be the same as those shown in the example for detail [29](#) for each of the sub-elements returned by **vpiElement**. The indices will be retrieved in right-to-left order as they appear in the text.
- 23) For an array net, **vpi_iterate(vpiRange, handle)** shall return the set of array range declarations beginning with the leftmost unpacked range of the array declaration and iterating through the rightmost unpacked range. For a packed array (logic net), the iteration shall return the set of ranges beginning with the leftmost packed range and iterating through the rightmost packed range. For a logic net, the **vpiLeftRange** and **vpiRightRange** relations shall return the bounds of the leftmost packed dimension.
- 24) **vpiArrayNet** is #defined the same as **vpiNetArray** for backward compatibility. A call to **vpi_get_str(vpiType, <array_net_handle>)** may return either “vpiArrayNet” or “vpiNetArray”.
- 25) A logic net without a packed dimension defined is a scalar; and for that object the property **vpiScalar** shall return `TRUE` and the property **vpiVector** shall return `FALSE`. A logic net with one or more packed dimensions defined is a vector, and the property **vpiVector** shall return `TRUE` (**vpiScalar** shall return `FALSE`). Packed struct nets and packed array nets are vectors, and the property **vpiVector** shall return `TRUE` (**vpiScalar** shall return `FALSE`). A net bit is a scalar, and the property **vpiScalar** shall return `TRUE` (**vpiVector** shall return `FALSE`). The properties **vpiScalar** and **vpiVector** when queried on a handle to an enum net shall return the value of the respective property for an object for which the typespec is the same as the base typespec of the typespec of the enum net. For an integer net or a time net, the property **vpiVector** shall return `TRUE` (**vpiScalar** shall return `FALSE`). For an array net, the **vpiScalar** and **vpiVector** properties shall return the values of the respective properties for an array element. The **vpiScalar** and **vpiVector** properties shall return `FALSE` for all other net objects.
- 26) **vpiLogicNet** is #defined the same as **vpiNet** for backward compatibility. A call to **vpi_get_str(vpiType, <logic_net_handle>)** may return either “vpiLogicNet” or “vpiNet”.
- 27) Neither an array net nor an unpacked struct net has a value property.
- 28) The **vpiParent** transition shall be allowed on all net objects. It shall return one of the types of objects listed below, representing one of its prefix objects (field select prefix or indexing select prefix as described in [11.5.3](#)), or `NULL`, depending on whether certain criteria are met. For purposes of defining **vpiParent**, a prefix object is the object obtained from successively removing the rightmost index or identifier from a compound or indexed/multidimensional object name.

Consider the following **vpiArrayNet** objects:

```
wire logic [1:0][2:3] mda [4:6][6:8];
wire struct { int i1; logic[1:0][2:3] bvec[4:5]; } spa [9:11][12:13];
```

`mda[6][8][1][3]` is a **vpiLogicNet**, `mda[6][8][1]` is its first prefix object (a 2-bit **vpiLogicNet** vector), and `mda[6][8]` is its second prefix object (a 2 x 2 packed array **vpiLogicNet**), etc. The `spa[9][12].bvec[4]` object is a **vpiLogicNet** (a 2 x 2 packed array **vpiLogicNet**), and `spa[9][12].bvec` is its first prefix object (a **vpiArrayNet** struct member), and `spa[9][12]` is the second prefix object (the **vpiStructNet** containing the `bvec` member). etc.

For a net object with prefix objects, the **vpiParent** transition shall return one of the following prefix objects, whichever comes first in prefix order (rightmost to leftmost):

- Struct or union net
- Struct or union member net
- The largest containing packed array net object
- The largest containing unpacked array net object

If there is no prefix object, or no prefix object meets at least one of the above criteria, **vpiParent** shall return NULL.

Using the declarations above, the **vpiParent** of `mda[6][8][1][3]` is `mda[6][8]`, the **vpiLogicNet** representing the largest containing packed array prefix; the **vpiParent** of `mda[6][8]` is `mda`, the **vpiArrayNet** representing the largest containing unpacked array net prefix. Likewise, the **vpiParent** of `spa[9][12].bvec[4][0]` is `spa[9][12].bvec[4]` (the largest containing packed array net); the **vpiParent** of `spa[9][12].bvec[4]` is `spa[9][12].bvec` (struct member), and applying **vpiParent** again yields `spa[9][12]`, the struct net for member `bvec`. The **vpiParent** of `spa[9][12]` is `spa`, the largest containing unpacked array of the struct net; **vpiParent** of `spa` (or `mda`) would return NULL.

- 29) The **vpiElement** transition shall be used to iterate over the sub-elements of packed array nets. Unlike **vpiNet** iterations for **vpiArrayNet** objects, **vpiElement** shall retrieve elements for only one dimension level at a time. This means that for multi-dimensioned packed array nets, **vpiElement** shall retrieve elements which are themselves also **vpiPackedArrayNet** objects. **vpiElement** can then be used to iterate over the sub-elements of these objects and so on, until the leaf level struct nets or enum nets are returned. In other words, the data type of each element retrieved by **vpiElement** is equivalent to the original **vpiPackedArrayNet** object's data type with one leftmost packed range removed. For example, consider the following **vpiPackedArrayNet** object:

```
typedef struct packed { integer i1; logic [1:0][2:3]bvec; } pavartype;
wire pavartype [0:2][6:3] panet1;
```

The **vpiElement** transition applied to `panet1` shall return 3 **vpiPackedArrayNet** objects: `panet1[0]`, `panet1[1]`, and `panet1[2]`. The **vpiElement** transition applied to **vpiPackedArrayNet** `panet1[0]` in turn shall retrieve **vpiStructNet** objects `panet1[0][6]`, `panet1[0][5]`, `panet1[0][4]`, and `panet1[0][3]` respectively. Also, the **vpiParent** transition for all the above-mentioned sub-elements of `panet1` shall return `panet1` (as per detail 28), since `panet1` is “the largest containing packed array net object”.

- 30) The **vpiStructUnionMember** property shall be TRUE for any enum net, integer net, time net, struct net, packed array net, or array net that is a direct member of a struct net, i.e. whose **vpiParent** is a struct net (see detail 28). This property shall be FALSE for any net, array net, or net bit whose **vpiParent** is not a struct net.

37.17 Variables

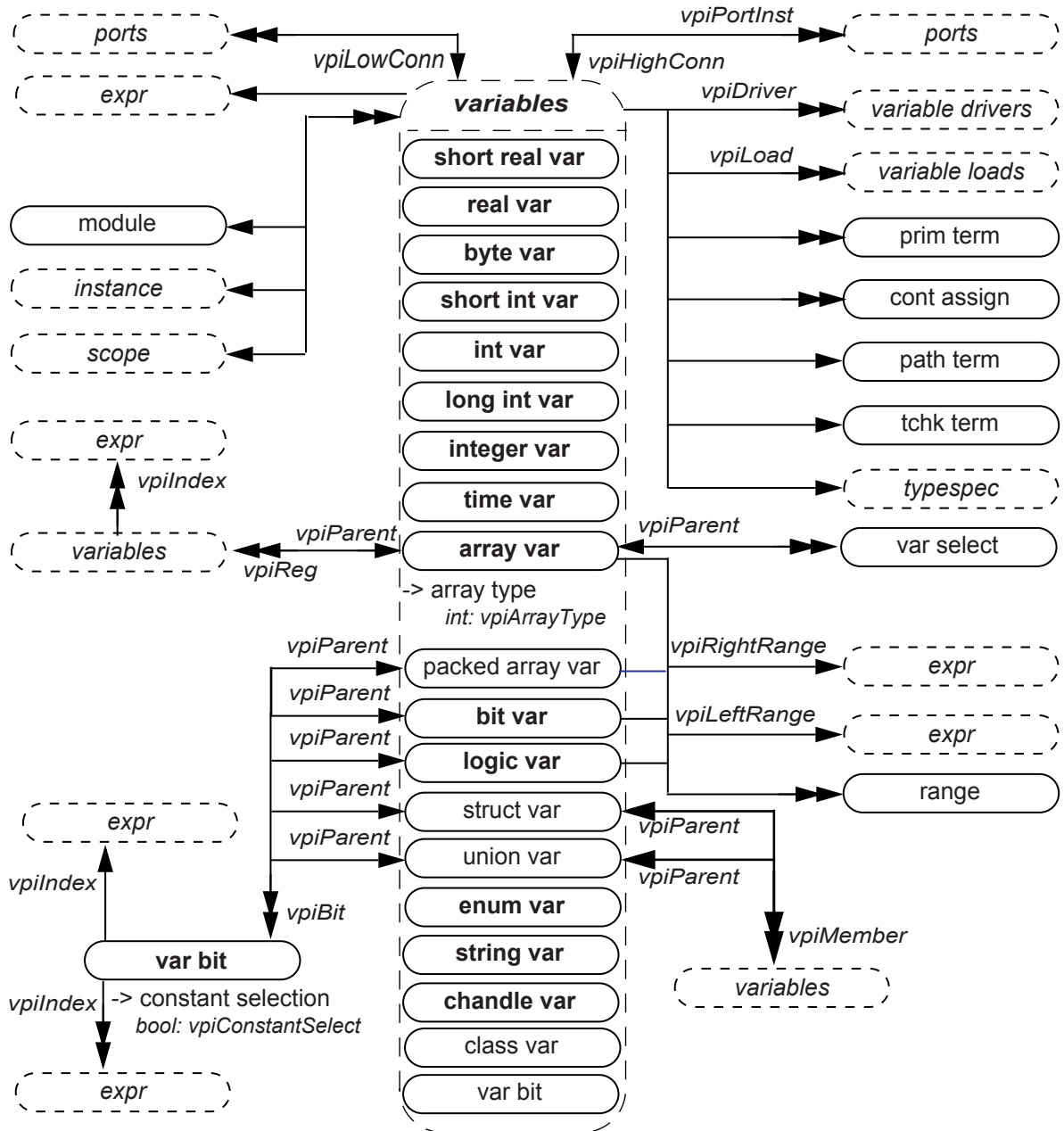

- > access by index
vpi_handle_by_index()
vpi_handle_by_multi_index()
- > array member
bool: vpiArray (deprecated)
bool: vpiArrayMember
- > name
str: vpiName
str: vpiFullName
- > sign
bool: vpiSigned
- > size
int: vpiSize

- > lifetime
bool: vpiAutomatic
- > memory allocation
int: vpiAllocScheme
- > constant variable
bool: vpiConstantVariable
- > determine random availability
bool: vpiIsRandomized
- > randomization type
int: vpiRandType

- > member
bool: vpiStructUnionMember
- > value
vpi_get_value()
vpi_put_value()
- > scalar
bool: vpiScalar
- > visibility
int: vpiVisibility
- > vector
bool: vpiVector

Details

- 1) Any variable declared as an array with one or more unpacked ranges is an array var.
- 2) The Boolean property **vpiArray** is deprecated in this standard. The Boolean property **vpiArrayMember** shall be `TRUE` if the referenced variable is a member of an array variable. It shall be `FALSE` otherwise.
- 3) To obtain the members of a union and structure, see the relations in [37.24](#).
- 4) For an array var, **vpi_iterate(vpiRange, handle)** shall return the set of array range declarations beginning with the leftmost unpacked range and iterating through the rightmost unpacked range. If any dimension of the unpacked array other than the first dimension is a dynamic array, associative array, or queue dimension, the iteration shall return an empty range (see [37.22](#)) for that dimension. For a packed array, the iteration shall return the set of ranges beginning with the leftmost packed range and iterating through the rightmost packed range. The ranges returned for a packed array shall not include the implicit range for packed struct or union var elements themselves, or the range (explicit or implicit) for the base type of enum var elements.
- 5) **vpi_handle(vpiIndex, var_select_handle)** shall return the index of a var select in a one-dimensional array. **vpi_iterate(vpiIndex, var_select_handle)** shall return the set of indices for a var select in a multidimensional array, starting with the index for the var select and working outward.
- 6) The **vpiLeftRange** and **vpiRightRange** relations shall return the bounds of the leftmost packed dimension for a packed array and of the leftmost unpacked dimension for an unpacked array. If the unpacked array has no members, **vpiLeftRange** and **vpiRightRange** shall return `NULL`.
- 7) A var select is an element selected from an array var.
- 8) If the variable has an initialization expression, the expression can be obtained from **vpi_handle(vpiExpr, var_handle)**.
- 9) **vpiSize** for a variable array shall return the number of variables in the array. For variables belonging to an integer data type (see [6.11](#)), for enum vars, and for packed struct and union variables, **vpiSize** shall return the size of the variable in bits. For a string var, it shall return the number of characters that the variable currently contains. For unpacked structures and unions, the size returned indicates the number of fields in the structure or union. For a var bit, **vpiSize** shall return 1. For all other variables, the behavior of the **vpiSize** property is not defined.
- 10) **vpiSize** for a var select shall return the number of bits in the var select. This applies only for packed var select.
- 11) Variables of type **vpiArrayVar** or **vpiClassVar** do not have a value property. Struct var and union var variables for which the **vpiVector** property is `FALSE` do not have a value property.
- 12) **vpiBit** iterator applies only for logic, bit, packed struct, packed union, and packed array variables.
- 13) **vpi_handle(vpiIndex, var_bit_handle)** shall return the bit index for the variable bit. **vpi_iterate(vpiIndex, var_bit_handle)** shall return the set of indices for a multidimensional variable bit select, starting with the index for the bit and working outwards.
- 14) **cbSizeChange** shall be applicable only for dynamic and associative arrays, for queues, and for string vars. If both value and size change, the size change callback shall be invoked first. This callback fires after the size change occurs and before any value changes for that variable. The value in the callback is the new size of the array.
- 15) The property **vpiRandType** returns the current randomization type for the variable, which can be one of **vpiRand**, **vpiRandC**, and **vpiNotRand**.
- 16) **vpiIsRandomized** is a property to determine whether a random variable is currently active for randomization.
- 17) When the **vpiStructUnionMember** property is `TRUE`, it indicates that the variable is a member of a parent struct or union variable. See also the relations in [37.24](#) and [37.18](#) detail [5](#).
- 18) If a variable is an element of an array (the **vpiArrayMember** property is `TRUE`), the **vpiIndex** iterator shall return the indexing expressions that select that specific variable out of the array. See [37.18](#) (and detail [6](#)) for similar functionality available for elements of packed array vars.
- 19) In the above diagram:

```
logic var == reg  
var bit == reg bit  
array var == reg array
```

vpiVarBit is #defined the same as **vpiRegBit** for backward compatibility. However, a **vpiVarBit** can be an element of a **vpiBitVar** (2-state) or a **vpiLogicVar** (4-state), whereas **vpiRegBit** could only be an element of a **vpiReg** (4-state).

SystemVerilog treats **reg** and **logic** variables as equivalent in all respects. To allow for backward compatibility, a call to **vpi_get_str(vpiType, <logic_var_handle>)** may return either “vpiLogicVar” or “vpiReg”. Similarly, **vpi_get_str(vpiType, <var_bit_handle>)** may return either “vpiVarBit” or “vpiRegBit”, while **vpi_get_str(vpiType, <array_var_handle>)** may return either “vpiArrayVar” or “vpiRegArray”.

- 20) A bit var or logic var, without a packed dimension defined, is a scalar and for those objects, the property **vpiScalar** shall return TRUE, and the property **vpiVector** shall return FALSE. A bit var or logic var, with one or more packed dimensions defined, is a vector, and the property **vpiVector** shall return TRUE (**vpiScalar** shall return FALSE). A packed struct var, a packed union var, and packed array var are vectors, and the property **vpiVector** shall return TRUE (**vpiScalar** shall return FALSE). A var bit is a scalar, and the property **vpiScalar** shall return TRUE (**vpiVector** shall return FALSE). The properties **vpiScalar** and **vpiVector** when queried on a handle to an enum var shall return the value of the respective property for an object for which the typespec is the same as the base typespec of the typespec of the enum var. For an integer var, time var, short int var, int var, long int var, and byte var, the property **vpiVector** shall return TRUE (**vpiScalar** shall return FALSE). For an array var, the **vpiScalar** and **vpiVector** properties shall return the values of the respective properties for an array element. The **vpiScalar** and **vpiVector** properties shall return FALSE for all other var objects.
- 21) **vpiArrayType** can be one of **vpiStaticArray**, **vpiDynamicArray**, **vpiAssocArray**, or **vpiQueue**.
- 22) **vpiRandType** can be one of **vpiRand**, **vpiRandC**, or **vpiNotRand**.
- 23) For details on lifetime and memory allocation properties, see [37.3.7](#).
- 24) **vpiVisibility** denotes the visibility (**local**, **protected**, or default) of a variable that is a class member. **vpiVisibility** shall return **vpiPublicVis** for a class member that is not **local** or **protected**, or for a variable that is not a class member.
- 25) A non-static data member of a class var does not have a **vpiFullName** property. The static data member of a class, referenced either via a class var or a class defn, has the **vpiFullName** property. It shall return a full name string representing the hierarchical path of the static variable through “class defn”. For example:

```

module top;
  class Packet ;
    static integer Id ;
    ....
  endclass
  Packet p;
  c = p.Id;
  ....

```

The **vpiFullName** for `p.Id` is “`top.Packet::Id`”.

- 26) The **vpiParent** transition shall be allowed on all variable objects. It shall return one of the types of objects listed below, representing one of its prefix objects (similar to the field select prefix or indexing select prefix as described in [11.5.3](#)), or NULL, depending on whether certain criteria are met. For purposes of defining **vpiParent**, a prefix object is the object obtained from successively removing the rightmost index or identifier from a compound or indexed/multidimensional object name (excluding scope identifiers).

Consider the following **vpiArrayVar** objects:

```

logic [1:0][2:3] mda [4:6][6:8];
struct { int i1; bit [1:0][2:3] bvec[4:5]; } spa [9:11][12:13];

```

`mda[6][8][1][3]` is a **vpiVarBit**, `mda[6][8][1]` is its first prefix object (a 2-bit **vpiLogicVar** vector), and `mda[6][8]` is its second prefix object (a 2 x 2 **vpiLogicVar** packed array), etc. The `spa[9][12].bvec[4]` object is a **vpiBitVar** (a 2 x 2 **vpiBitVar** packed array), and `spa[9][12].bvec` is its first prefix object (a **vpiArrayVar** struct member), and `spa[9][12]` is the second prefix object (the **vpiStructVar** containing the **bvec** member), etc.

For a variable object with prefix objects, the **vpiParent** transition shall return one of the following prefix objects, whichever comes first in prefix order (rightmost to leftmost):

- Struct, union, or class variable
- Struct or union member variable, or class variable data member
- The largest containing packed array object
- The largest containing unpacked array object

If there is no prefix object, or no prefix object meets at least one of the above criteria, **vpiParent** shall return

NULL.

Using the declarations above, the **vpiParent** of `mda[6][8][1][3]` is `mda[6][8]`, the **vpiLogicVar** representing the largest containing packed array prefix; the **vpiParent** of `mda[6][8]` is `mda`, the **vpiArrayVar** representing the largest containing unpacked array prefix. Likewise, the **vpiParent** of `spa[9][12].bvec[4][0]` is `spa[9][12].bvec[4]` (the largest containing packed array); the **vpiParent** of `spa[9][12].bvec[4]` is `spa[9][12].bvec` (struct member), and applying **vpiParent** again yields `spa[9][12]`, the struct variable for member `bvec`. The **vpiParent** of `spa[9][12]` is `spa`, the largest containing unpacked array of the struct variable; **vpiParent** of `spa` (or `mda`) would return NULL.

Class variables (as mentioned in the prefix object types above) shall be returned as parent objects only when they are explicitly used to reference corresponding class data members in the design. A VPI handle to a data member that does not correspond to such an explicit reference in the design (e.g. a VPI handle to a data member derived from iterations on its **vpiClassObj** or **vpiClassDefn**) shall have a NULL parent.

- 27) The property **vpiConstantSelect** shall return TRUE for a var bit or other variable if it has a static lifetime and has no parent (the **vpiParent** relation returns NULL) or if both of the following are true of the “select” part of the equivalent primary expression (see [A.8.4](#)):
- Every index expression in the select is an elaboration time constant expression.
 - Every element within the select denotes either a member of a struct or union variable or a member of a packed or unpacked array with static bounds.

Otherwise, **vpiConstantSelect** shall return FALSE.

NOTE 1—The final (non-prefix) element of the select may be an unindexed member identifier belonging to any VPI variable type. It may, for example, be the name of a class variable or dynamic array. However, it must not be a member of a class variable if the member has an automatic lifetime, and it must not be an element of a dynamically allocated array.

NOTE 2—If **vpiConstantSelect** is TRUE, then if the handle refers to a valid underlying simulation object at the beginning of simulation (or at any point in the simulation), it refers to the same object at all points in the simulation. Moreover, if any index expression is in or out of bounds at the beginning of simulation, it is in or out of bounds at all subsequent simulation times as well.

37.18 Packed array variables

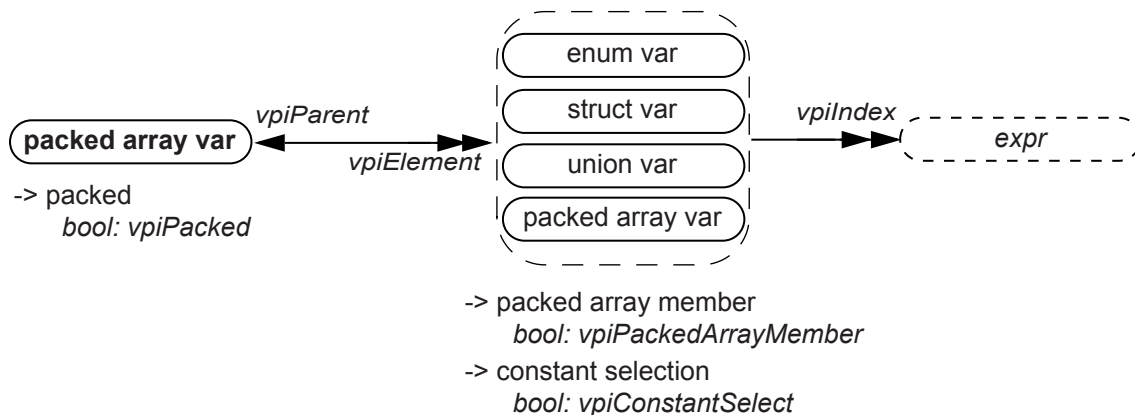

- 1) **vpiPackedArrayVar** objects shall represent packed arrays of packed struct var, union var, or enum var objects. The properties **vpiVector**, and **vpiPacked** for these objects and their underlying struct var, union var, or enum var elements shall always be TRUE (see [37.17](#)).
- 2) For consistency with other variable-width vector objects, the **vpiSize** property for **vpiPackedArrayVar** objects shall be the number of bits in the packed array, not the number of struct, enum, or union var elements. The total number of struct var, enum var, or union var elements for a packed array var can be obtained by computing the product of the **vpiSize** property for all of its packed ranges.
- 3) The **vpiElement** transition shall be used to iterate over the sub-elements of packed array variables. Unlike **vpiVarSelect** or **vpiReg** transitions for **vpiArrayVar** objects, **vpiElement** shall retrieve elements for only one

dimension level at a time. This means that for multi-dimensioned packed arrays, **vpiElement** shall retrieve elements which are themselves also **vpiPackedArrayVar** objects. **vpiElement** can then be used to iterate over the sub-elements of these objects and so on, until the leaf level struct, enum, or union vars are returned. In other words, the datatype of each element retrieved by **vpiElement** is equivalent to the original **vpiPackedArrayVar** object's datatype with the leftmost packed range removed. For example, consider the following **vpiPackedArrayVar** object:

```
typedef struct packed { int i1; bit [1:0][2:3]bvec; } pavartype;
pavartype [0:2][6:3] pavar1;
```

The **vpiElement** transition applied to `pavar1` shall return 3 **vpiPackedArrayVar** objects: `pavar1[0]`, `pavar1[1]`, and `pavar1[2]`. The **vpiElement** transition applied to **vpiPackedArrayVar** `pavar1[0]` in turn shall retrieve **vpiStructVar** objects `pavar1[0][6]`, `pavar1[0][5]`, `pavar1[0][4]`, and `pavar1[0][3]` respectively. Also, the **vpiParent** transition for all the above-mentioned sub-elements of `pavar1` shall return `pavar1` (as per detail 26 of 37.17, since `pavar1` is “the largest containing packed array object”).

- 4) The **vpiPackedArrayMember** property shall be TRUE for any struct var, union var, enum var, or packed array var whose **vpiParent** is a packed array var (see detail 26 of 37.17).
- 5) The **vpiStructUnionMember** property shall be TRUE only for packed array vars that are direct members of struct or union vars, i.e. whose **vpiParent** is a struct or union var (see detail 26 of 37.17). This property shall be FALSE for all sub-elements (as returned by the **vpiElement** iterator) of such packed array vars.
- 6) **vpi_iterate(vpiIndex, packed_array_var_handle)** shall return the set of indices for a sub-element of a packed array variable (relative to its **vpiParent**), starting with the index for the sub-element and working outwards. The indices retrieved shall be the same as those shown in the example for detail 3 for each of the sub-elements returned by **vpiElement**. The indices will be retrieved in right-to-left order as they appear in the text.

37.19 Variable select

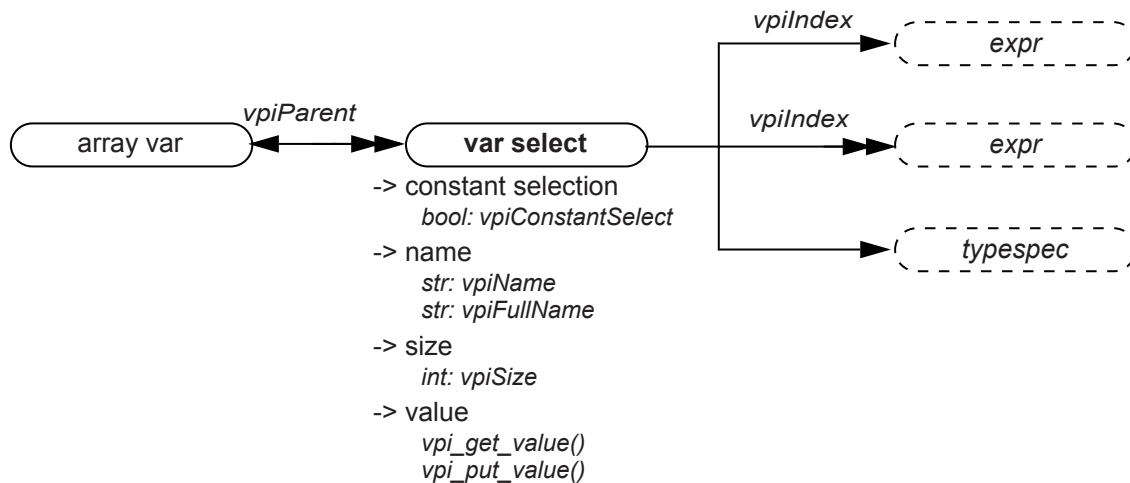

Details:

- 1) The property **vpiConstantSelect** shall return TRUE for a var select if
 - every associated index expression is an elaboration time constant expression, and
 - the parent of the var select is an unpacked array with static bounds, and
 - **vpiConstantSelect** returns TRUE for the parent of the var select.

Otherwise, **vpiConstantSelect** shall return FALSE.

NOTE—If **vpiConstantSelect** is TRUE, then if the handle refers to a valid underlying simulation object at the beginning of simulation (or at any point in the simulation), it refers to the same object at all points in the simulation. Moreover, if an index expression of the var select or of any of its parents is in or out of bounds at the beginning of simulation, it is in or out of bounds at all subsequent simulation times as well.

37.20 Memory

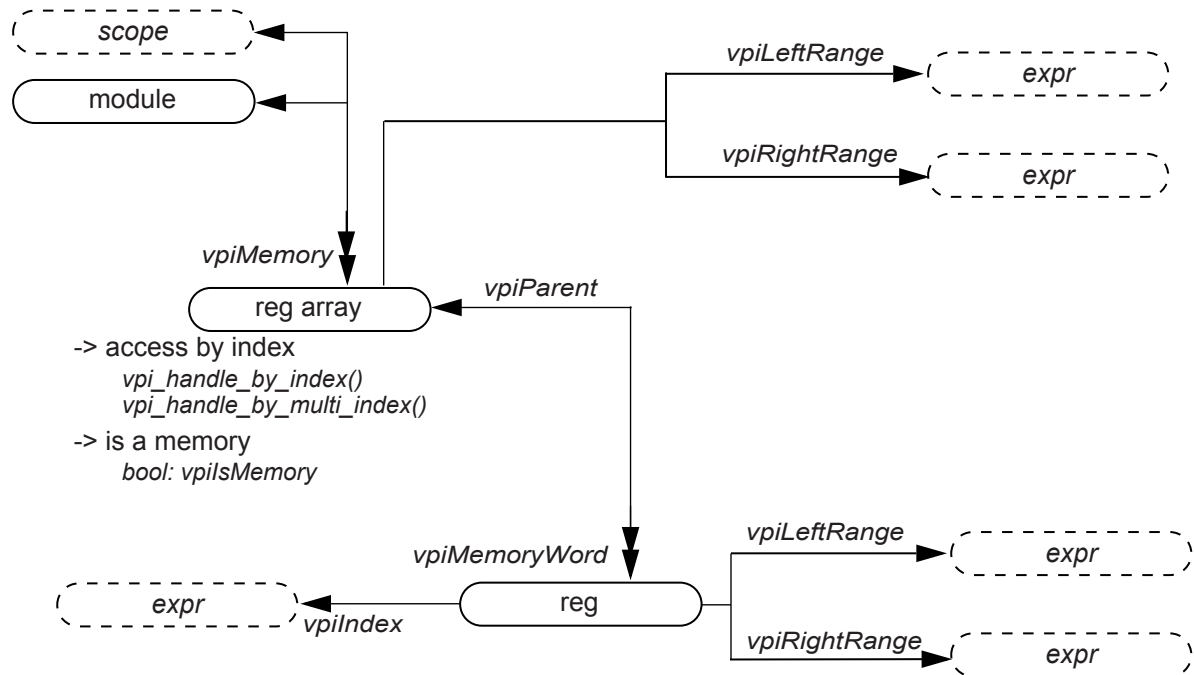

Details:

- 1) The objects **vpiMemory** and **vpiMemoryWord** have been generalized with the addition of arrays of variables. To preserve backwards compatibility, they have been converted into methods which will return objects of type **vpiRegArray** and **vpiReg** respectively. See [37.17](#) for the definitions of variables and variable arrays.

37.21 Variable drivers and loads

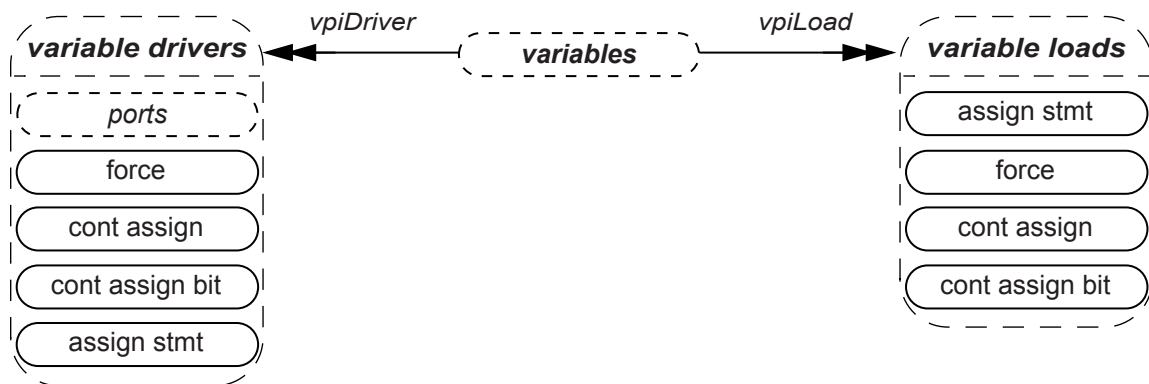

Details:

- 1) **vpiDrivers/Loads** for a structure, union, or class variable shall include the following:
 - Driver/Load for the whole variable
 - Driver/Load for any bit-select or part-select of that variable
 - Driver/Load of any member nested inside that variable
- 2) **vpiDrivers/Loads** for any variable array should include driver/load for entire array/vector or any portion of an array/vector to which a handle can be obtained.

37.22 Object Range

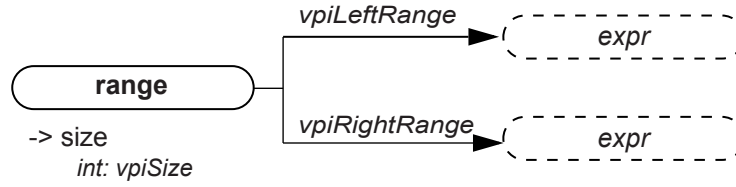

Details:

- 1) An empty range is a range that has no elements. A range corresponding to an empty dynamic array, associative array, or queue is an empty range. A range of a typespec for a dynamic array, associative array, or queue is also an empty range.
- 2) For an empty range, **vpiSize** shall return 0, while the **vpiLeftRange** and **vpiRightRange** relations shall each return NULL.

37.23 Typespec

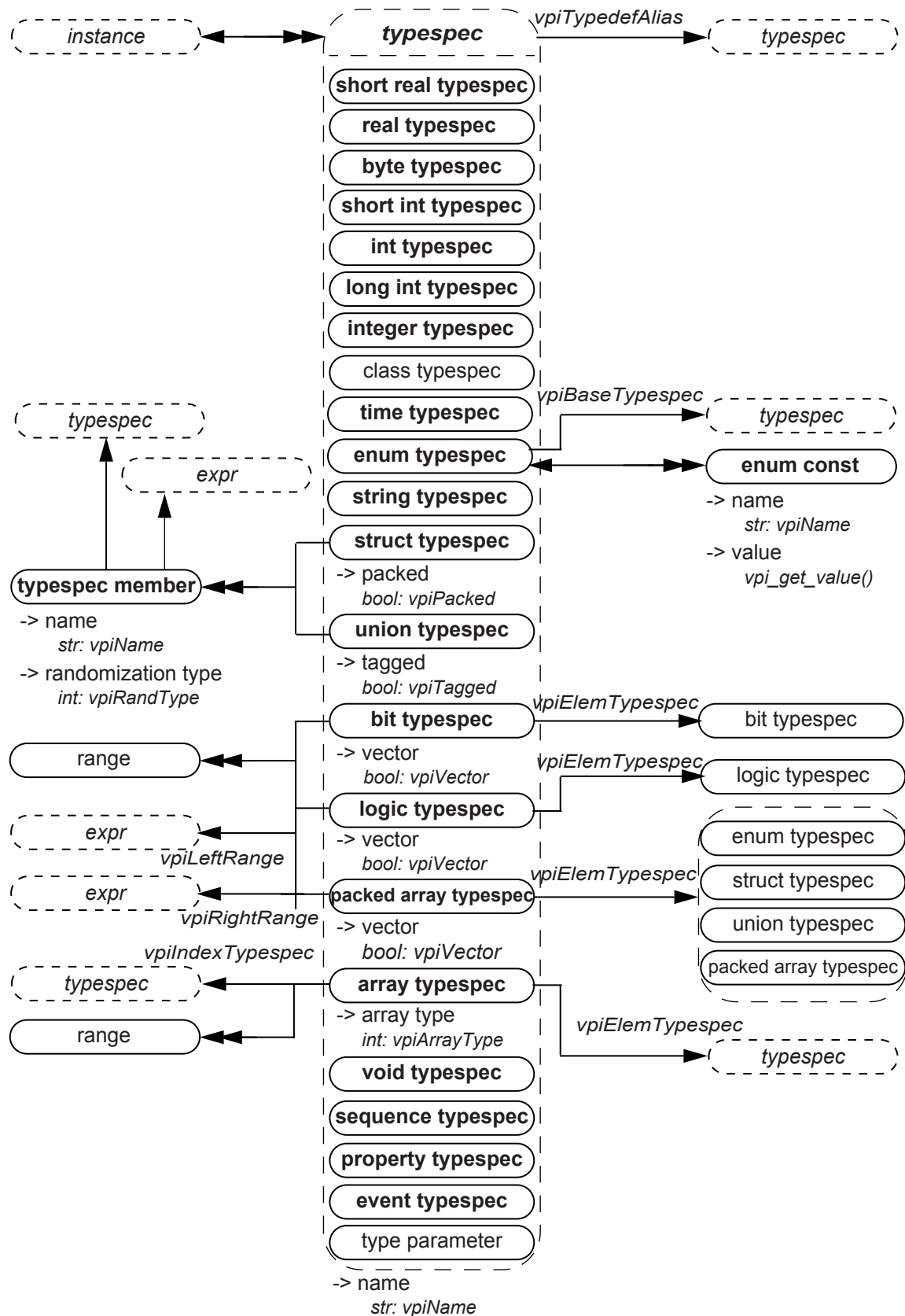

Details:

- 1) If a typespec denotes a type that has a user-defined typedef, the **vpiName** property shall return the name of that type; otherwise, except in the case of a class typespec (see 37.28), the **vpiName** property shall return NULL. Consequently the **vpiName** property returns NULL for any SystemVerilog built-in type. If the typespec denotes a type with a typedef that creates an alias of another typedef, then the **vpiTypedefAlias** of the typespec shall return a non-null handle, which represents the handle to the aliased typedef. For example:

```
typedef enum bit [0:2] {red, yellow, blue} primary_colors;
typedef primary_colors colors;
```

If “h1” is a handle to the typespec `colors`, its **vpiType** shall return **vpiEnumTypespec**, the **vpiName** property shall return “colors”, **vpiTypedefAlias** shall return a handle “h2” to the typespec “primary_colors” of **vpiType vpiEnumTypespec**. The **vpiName** property for “h2” shall return “primary_colors”, and its **vpiTypedefAlias** shall return NULL.

- 2) **vpiIndexTypespec** relation is present only on associative array typespecs and returns the type that is used as the key into the associative array. For the wildcard index type (see 7.8.1), **vpiIndexTypespec** shall return NULL.
- 3) If the value of the property **vpiType** of a typespec is **vpiStructTypespec** or **vpiUnionTypespec**, then it is possible to iterate over **vpiTypespecMember** to obtain the structure of the user-defined type. For each typespec member, the typespec relation indicates the type of the member.
- 4) The property **vpiName** of a typespec member returns the name of the corresponding member, rather than the name (if any) of the associated typespec.
- 5) The name of a **typedef** may be the empty string if the typespec denotes typedef field defined in line rather than via a typedef declaration. For example:

```
typedef struct {
    struct
        int a;
    } B
} C;
```

The typespec representing the typedef C is a struct typespec; it has a single typespec member named B. The typespec relation for B returns another struct typespec that has no name and has a single typespec member named “a”. The typespec relation for “a” returns an int typespec.

- 6) If a type is defined as an alias of another type, it inherits the **vpiType** of this other type. For example:

```
typedef time my_time;
my_time t;
```

The **vpiTypespec** of the variable named “t” shall return a handle h1 to the typespec “my_time” whose **vpiType** shall be a **vpiTimeTypespec**. The **vpiTypedefAlias** applied to handle h1 shall return a typespec handle h2 to the predefined type “time”.

- 7) The expr associated with a typespec member shall represent the explicit default member value, if any, of the corresponding member of an unpacked structure data type (See 7.2).
- 8) The **vpiElemTypespec** transition shall be used to unwind the typespec of an unpacked array (array typespec) or a packed array (packed array typespec, or a bit or logic typespec with one or more dimensions) one dimension level at a time. This means that for a multi-dimensional array typespec (a typespec with more than one unpacked range), **vpi_handle(vpiElemTypespec, array_typespec_handle)** shall initially retrieve a **vpiArrayTypespec** equivalent to the original typespec with its leftmost unpacked range removed. Subsequent calls to the **vpiElemTypespec** method continue the unwinding until a typespec object is retrieved that has no unpacked ranges remaining. Similarly, when the **vpiElemTypespec** is applied to a typespec of a multi-dimensional packed array object, a **vpiPackedArrayTypespec** (or **vpiBitTypespec** or **vpiLogicTypespec**) is retrieved which is equivalent to the original typespec with its leftmost packed range removed, and so on, until a typespec without an explicit packed range is retrieved. When the **vpiElemTypespec** relation is applied to a **vpiStructTypespec**, **vpiUnionTypespec**, **vpiEnumTypespec**, or a **vpiBitTypespec** or **vpiLogicTypespec** with no ranges present, it shall return NULL. This allows packed or unpacked array typespecs constructed with multiple typedefs to be unwound without losing name information. Consider the complex array typespec defined below for `arr`:

```
typedef struct packed { int i1; bit bvec; } [1:3] parrtype;
typedef parrtype [2:1] parrtype2;
```

```
typedef parrtype2 unparrtype [6:4];
unparrtype arr [3:0];
```

The typespec of the object `arr` is an unpacked 4 x 3 array typespec with a NULL `vpiName` property. The typespec retrieved by applying `vpiElemTypespec` to this is a 3-element unpacked array typespec with a `vpiName` property of “`unparrtype`”. The typespec retrieved by using `vpiElemTypespec` on this in turn yields a 2 x 3 packed array typespec (of packed struct objects) with a `vpiName` property of “`parrtype2`”. Using `vpiElemTypespec` again in turn yields another packed array typespec (of 3 packed struct objects) with a `vpiName` property of “`parrtype`”. One more application of `vpiElemTypespec` to this result yields a struct typespec, a non-array typespec for which no further array sub-elements exist (the unwinding is done).

- 9) If a logic typespec, bit typespec, or packed array typespec has more than one packed dimension, `vpiLeftRange` and `vpiRightRange` shall return the bounds of the leftmost packed dimension. If an array typespec has more than one unpacked dimension, `vpiLeftRange` and `vpiRightRange` shall return the bounds of the leftmost unpacked dimension.
- 10) For an array typespec, `vpi_iterate(vpiRange, handle)` shall return the set of array range declarations beginning with the leftmost unpacked range and iterating through the rightmost unpacked range. If any dimension of the array typespec corresponds to a dynamic array, associative array, or queue, the iteration shall return an empty range (see [37.22](#)) for that dimension. For a logic typespec or bit typespec that has an associated range, the iteration shall return the set of ranges beginning with the leftmost packed range and iterating through the rightmost packed range.
- 11) In a context (such as a class defn) in which a type parameter has not been resolved, the type parameter itself shall act as a typespec.

37.24 Structures and unions

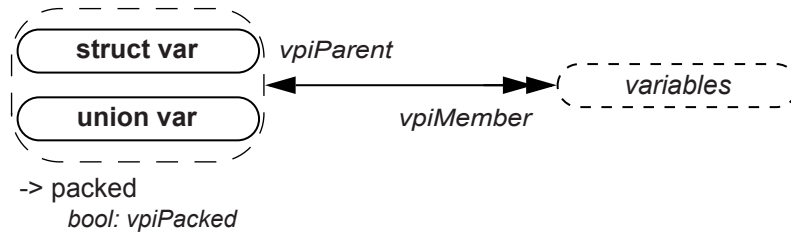

Details:

- 1) `vpi_get_value()/vpi_put_value()` cannot be used to access values of entire unpacked structures and unpacked unions.

37.25 Named events

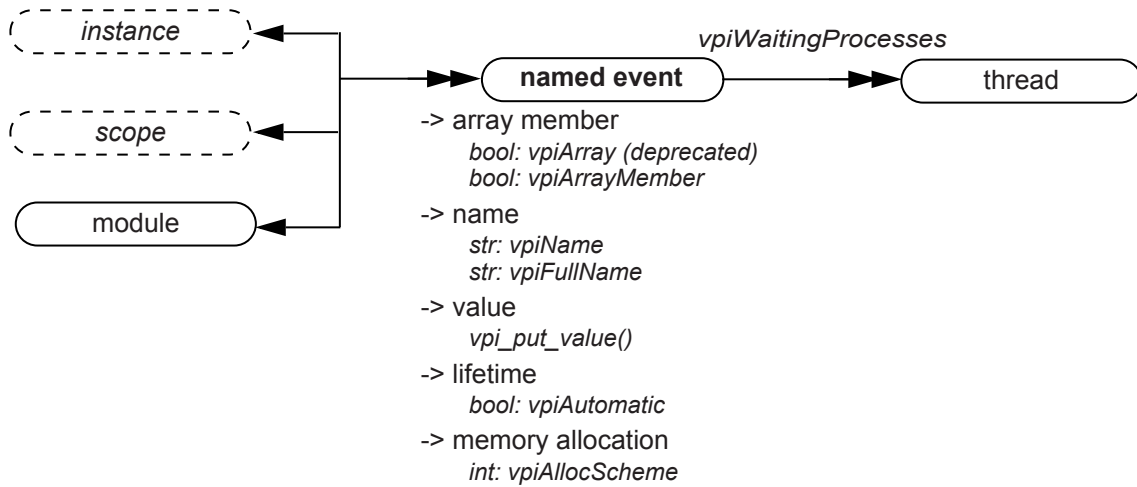

Details:

- 1) The **vpiWaitingProcesses** iterator returns all waiting processes, static or dynamic, identified by their thread, for that named event.
- 2) **vpi_iterate(vpiRange, named_event_array_handle)** shall return the set of array range declarations beginning with the leftmost unpacked range and iterating through the rightmost unpacked range.
- 3) For details on lifetime and memory allocation properties, see [37.3.7](#).

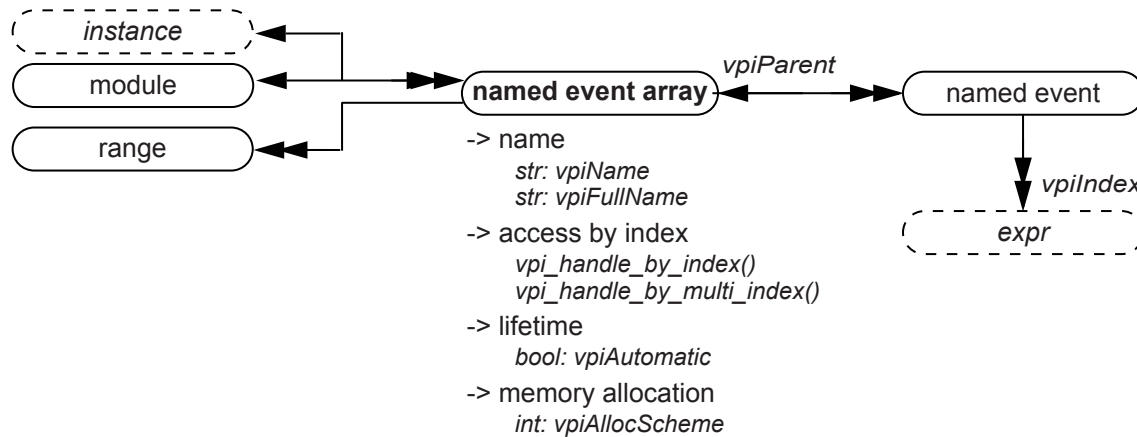

Details:

- 1) **vpi_iterate(vpiIndex, named_event_handle)** shall return the set of indices for a named event within an array, starting with the index for the named event and working outward. If the named event is not part of an array, a NULL shall be returned.
- 2) For details on lifetime and memory allocation properties, see [37.3.7](#).

37.26 Parameter, spec param, def param, param assign

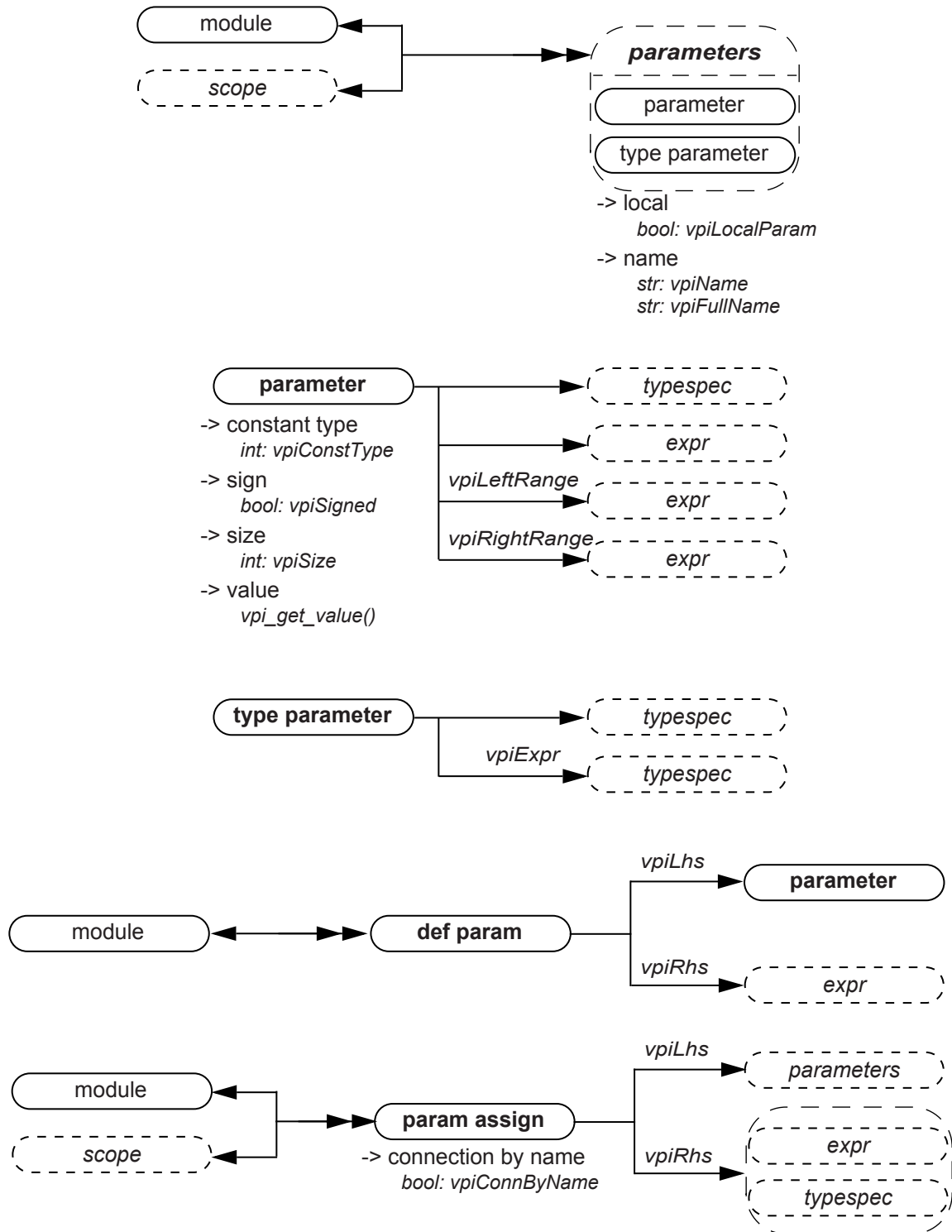

Details:

- 1) For a value parameter, **vpi_get_value()** shall return the value that the parameter has at the end of elaboration.

- 2) The **vpiTypespec** of a type parameter shall return the typespec that the type parameter has at the end of elaboration, but without resolving typedef aliases.
- 3) The **vpiExpr** relation of a value parameter shall return the default expr, while the **vpiExpr** relation of a type parameter shall return the default typespec.
- 4) **vpiLhs** from a param assign object shall return a handle to the overridden value parameter or type parameter.
- 5) If a value parameter does not have an explicitly defined range, **vpiLeftRange** and **vpiRightRange** shall return a NULL handle.

37.27 Class definition

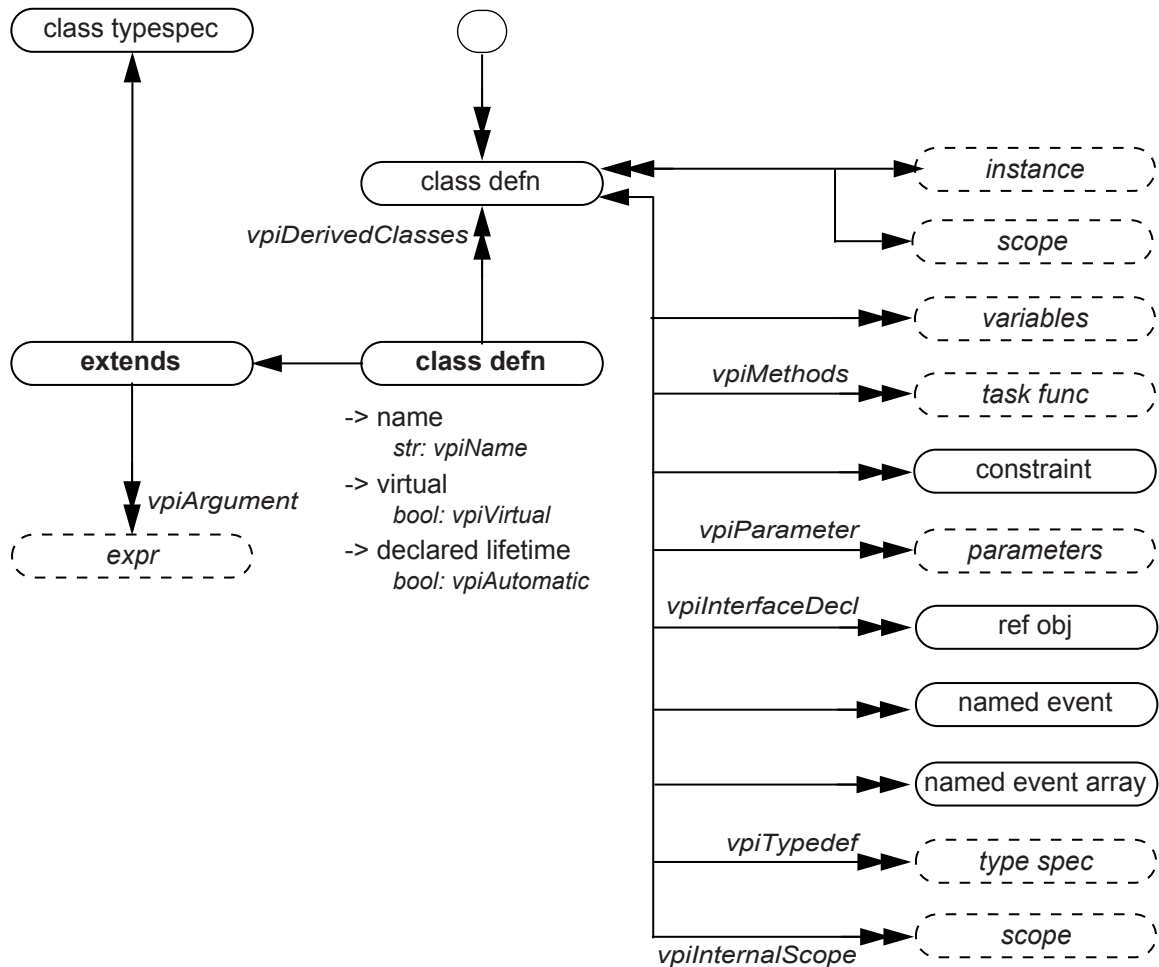

Details:

- 1) The iterations over **vpiVariables**, **vpiMethods**, **vpiNamedEvent**, and **vpiNamedEventArray** shall return both static and automatic properties or methods. However, the iteration over **vpiMethods** shall not include built-in methods for which there is no explicit declaration.
- 2) **vpi_get_value()** and **vpi_put_value()** are not allowed for variable and event handles obtained from class defn handles.
- 3) The iterator to constraints returns only normal constraints and not inline constraints.
- 4) To get constraints inherited from base classes, it is necessary to traverse the extends relation to obtain the base class typespec.

- 5) The **vpiDerivedClasses** iterator shall return all the class defns derived from the given class defn.
- 6) The relation to **vpiExtends** exists whenever one class is derived from another class (refer to 8.12). The relation from extends to class typespec provides the base class. The **vpiArgument** iterator from extends shall provide the arguments used in constructor chaining (refer to 8.16).
- 7) The **vpiInterfaceDecl** iteration returns the virtual interface declarations in the class definition.
- 8) The **vpiParameter** iteration shall return both the parameters declared in the parameter port list of the class declaration and the parameters declared within the body of the class declaration as class items. The property **vpiLocalParam** (see 37.26) shall return TRUE for parameters declared within the body.
- 9) For details on lifetime and memory allocation properties, see 37.3.7.

37.28 Class typespec

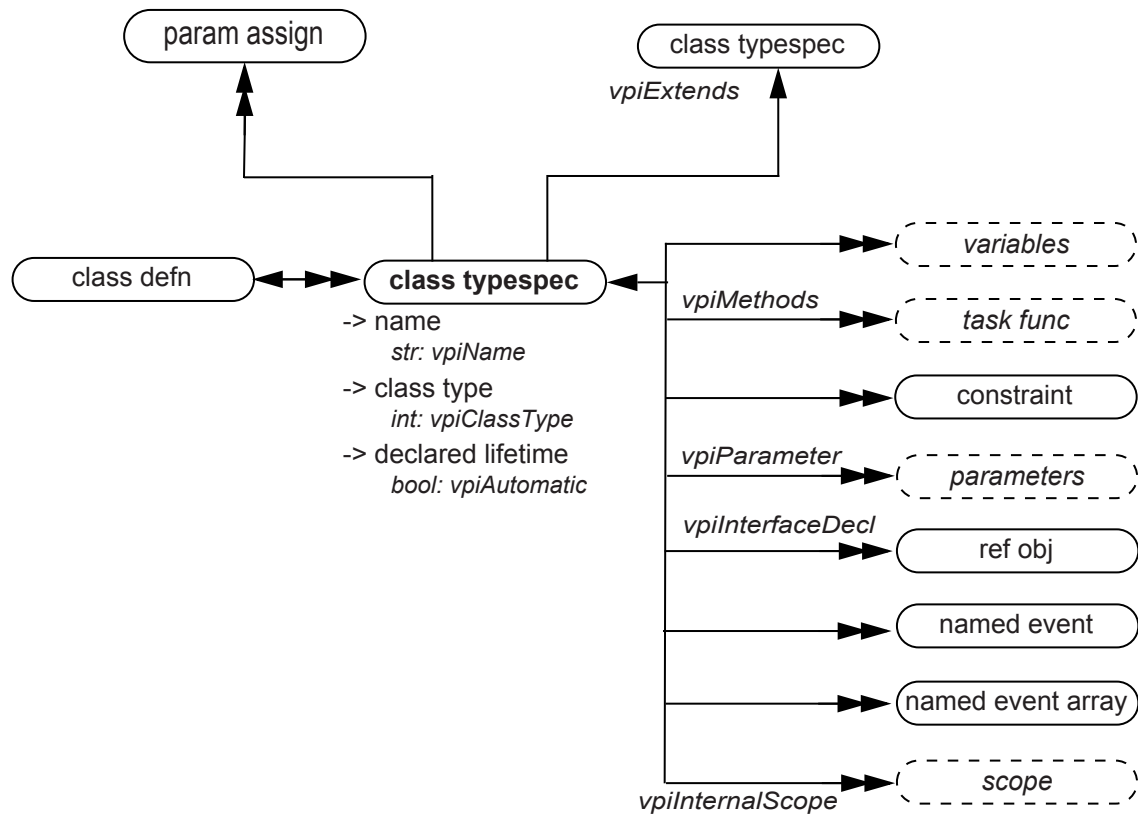

Details:

- 1) According to how it is obtained, a class typespec may represent either a lexical construct or a class specialization. If the class typespec is obtained as part of a class defn, it represents a lexical construct from the SystemVerilog source code. In particular, it shall represent a lexical construct under the following conditions:
 - It is obtained from a class defn via the **vpiTypedef** iteration. In this case it represents a user-defined typedef.
 - It is part of the declaration of a class item (variable or method) obtained from the class defn.
 - It is obtained from the extends object associated with the class defn.

A class typespec object that has all parameter values resolved shall represent a class specialization. In particular, it shall represent a class specialization under the following conditions:

 - It is obtained from a class defn by iterating over **vpiClassTypespec**.

- It is the type of a variable or method for which no containing scope is a class defn. If the variable or method is declared using the name of a typedef, the class typespec shall be the corresponding class instantiation rather than the class typespec for the typedef itself.

A class typespec derived from a class defn for which the parameter port list is empty may represent both a lexical construct and a class specialization.

- 2) For a class typespec that represents only a lexical construct, the one-to-many relations **vpiVariables**, **vpiMethods**, **vpiConstraint**, **vpiInterfaceDecl**, **vpiNamedEvent**, **vpiNamedEventArray**, **vpiTypedef**, and **vpiInternalScope** are not supported.
- 3) In the case of a class typespec that represents a lexical construct, if the class type construct includes an explicit parameter expression or type, the object for that parameter or type shall constitute the **vpiRhs** part of the corresponding param assign (see [37.26](#)); otherwise the **vpiRhs** part shall reference the default expression or type with which the parameter was declared. However, if the class typespec represents a class specialization, the **vpiRhs** of each param assignment may be any object that has the correct value (in the case of a non-type parameter) or type (in the case of a type parameter).
- 4) A class typespec that represents a class specialization shall have a valid, though tool-dependent, name.
- 5) From a class typespec that represents a class specialization, the iterations over **vpiVariables**, **vpiMethods**, **vpiNamedEvent**, and **vpiNamedEventArray** shall return both static and automatic properties or methods. However, the iteration over **vpiMethods** shall not include built-in methods for which there is no explicit declaration.
- 6) **vpi_get_value()** and **vpi_put_value()** are not allowed for non-static variable and event handles obtained from class typespec handles.
- 7) The iterator to constraints returns only normal constraints and not inline constraints.
- 8) To get constraints inherited from a base class typespec, it is necessary to traverse the extends relation to obtain the base class typespec.
- 9) The **vpiExtends** relation shall return the base class typespec, if any, from which a given class typespec is derived. The base class typespec of a class specialization shall also be a specialization.
- 10) The **vpiClassTypespec** iteration from a class defn shall return the class specializations derived directly (and not by inheritance) from that class defn.
- 11) The **vpiInterfaceDecl** iteration shall return the virtual interface declarations in the class specialization.
- 12) The **vpiParameter** iteration shall return parameters corresponding both to those declared in the parameter port list of the class declaration and to those declared within the body of the class declaration as class items. The property **vpiLocalParam** (see [37.26](#)) shall return TRUE for parameters declared within the body.
- 13) The **vpiClassDefn** relation shall return NULL for built-in classes.
- 14) For details on lifetime and memory allocation properties, see [37.3.7](#).

37.29 Class variables and class objects

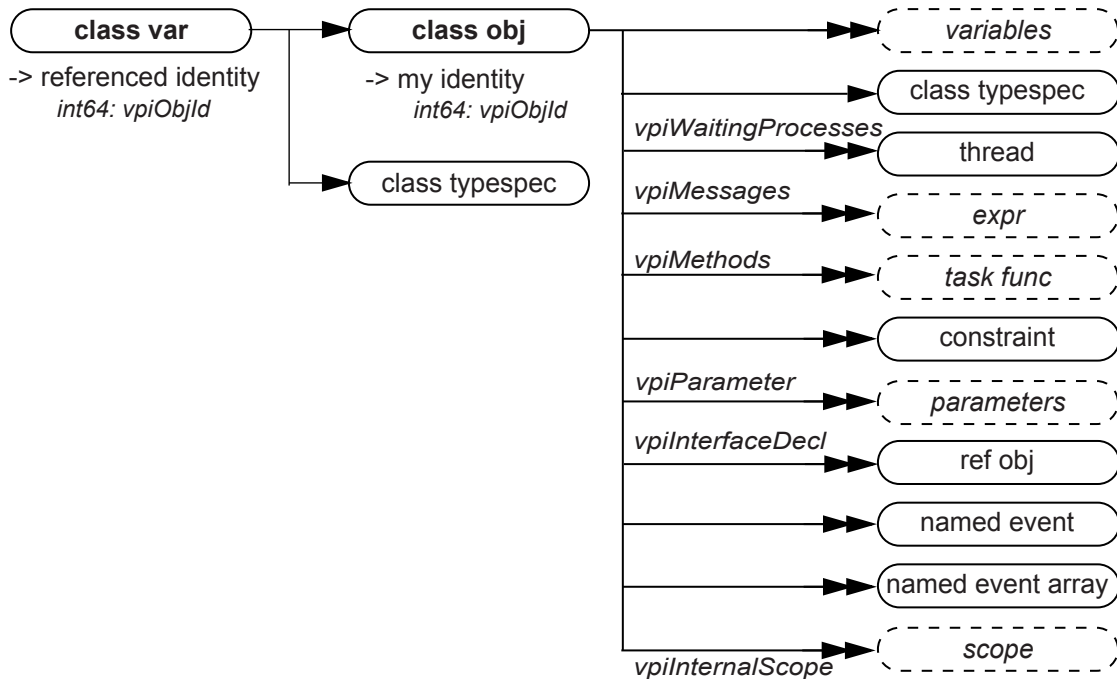

Details:

- 1) The property **vpiObjId** is a class object’s identifier. It is a property of a live object and guaranteed to be unique with respect to all other dynamic objects that support this property for as long as the object is alive. After the object is destroyed by garbage collection, its particular **vpiObjId** value may be reused.
- 2) For a class var, its **vpiObjId** is the identifier of the object it references or 0, indicating it is not referencing any object.
- 3) The **vpiWaitingProcesses** iterator on a mailbox or semaphore shall return the threads waiting on the class object or object resource. A waiting process is a static or dynamic process represented by its suspended thread. A process may be waiting to retrieve a message from a mailbox or waiting for a semaphore resource key.
- 4) A **vpiMessages** iteration shall return all the messages in a mailbox.
- 5) For a class var, **vpiClassTypespec** shall return the class typespec with which the class var was declared in the SystemVerilog source text. If the class var has the value of NULL, the **vpiClassObj** relationship applied to the class var shall return a null handle. **vpiClassTypespec** when applied to a class obj handle shall return the class typespec with which the class obj was created. The difference between the two usages of **vpiClassTypespec** can be seen in the example below:

```

class Packet;
...
endclass : Packet
class LinkedPacket extends Packet;
...
endclass : LinkedPacket
LinkedPacket l = new;
Packet p = l;
    
```

In this example, the **vpiClassTypespec** of variable p is Packet, but the **vpiClassTypespec** of the class obj associated with variable p is “LinkedPacket”.

NOTE—When a class var is obtained as a data member of a class typespec, the application must use **vpiScope** (see [37.12](#)) rather than **vpiClassTypespec** to obtain the enclosing scope.

- 6) From a class obj, the iterations over **vpiVariables**, **vpiMethods**, **vpiNamedEvent**, and **vpiNamedEventArray** shall return both static and automatic properties or methods. However, the iteration over **vpiMethods** shall not include built-in methods for which there is no explicit declaration.
- 7) The **vpiInterfaceDecl** iteration returns the virtual interfaces of the class object.
- 8) The **vpiParameter** iteration shall return parameters corresponding both to those declared in the parameter port list of the class declaration and to those declared within the body of the class declaration as class items. The property **vpiLocalParam** (see [37.26](#)) shall return TRUE for parameters declared with the body. The value of a parameter derived from a class obj shall be the same as that of the same parameter derived from the corresponding class typespec.
- 9) **vpi_handle_by_name()** shall accept a full name to a non-static data member, even though it does not have a **vpiFullName** property. For example:

```
module top;  
  class Packet ;  
    integer Id ;  
    ....  
  endclass  
  Packet p;  
  c = p.Id;  
  ....
```

vpi_handle_by_name() accepts “top.p.Id”.

- 10) For details on class object specific callbacks, see [38.36.1](#).

37.30 Constraint, constraint ordering, distribution

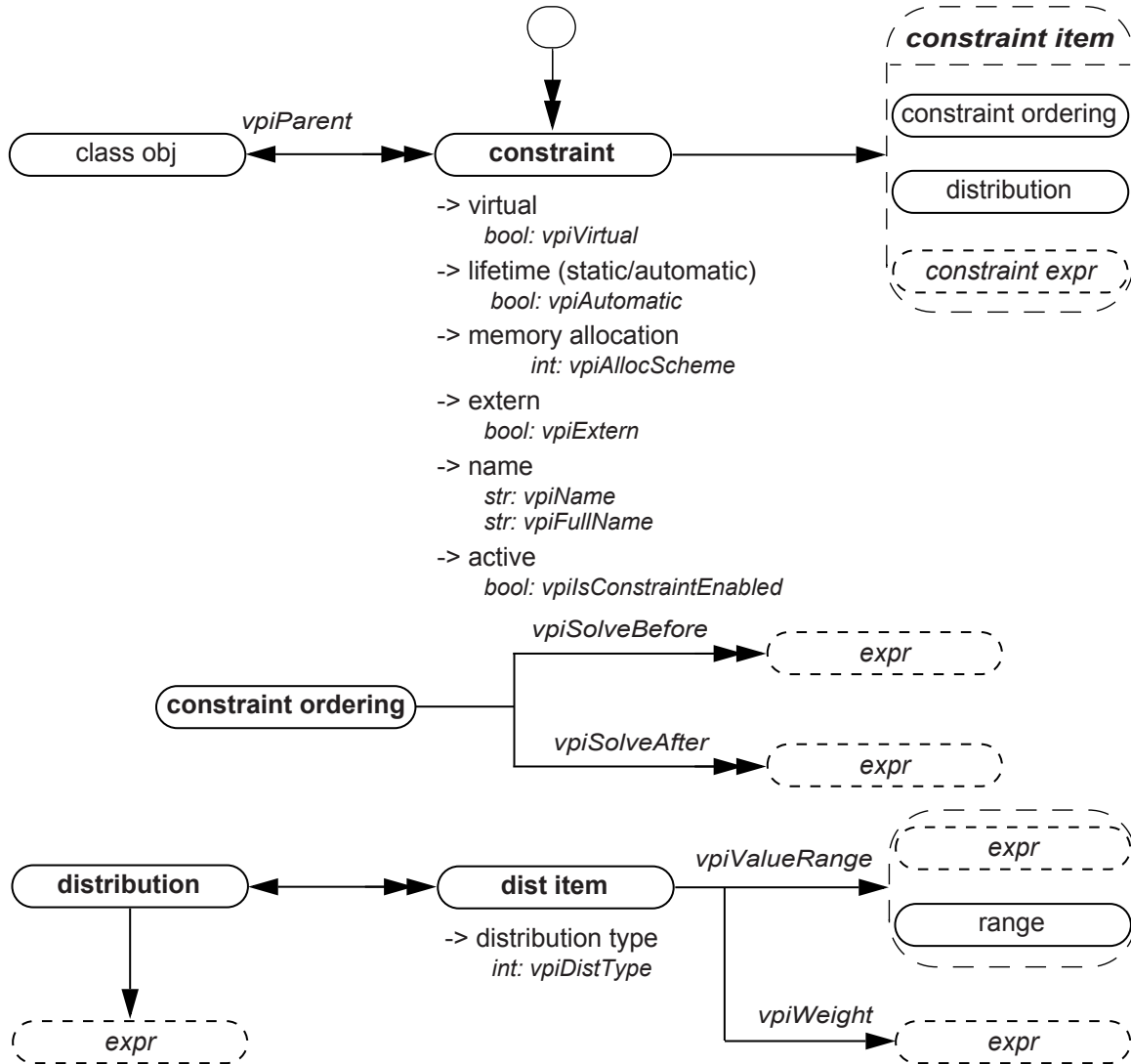

Details:

- 1) For a constraint, *vpiAutomatic* property does not mean lifetime, but reflects the keyword used in the constraint declaration. *vpiAutomatic == 0* implies the constraint was declared static. See [18.5.10](#) for meaning.
- 2) For details on memory allocation property, see [37.3.7](#).

37.31 Primitive, prim term

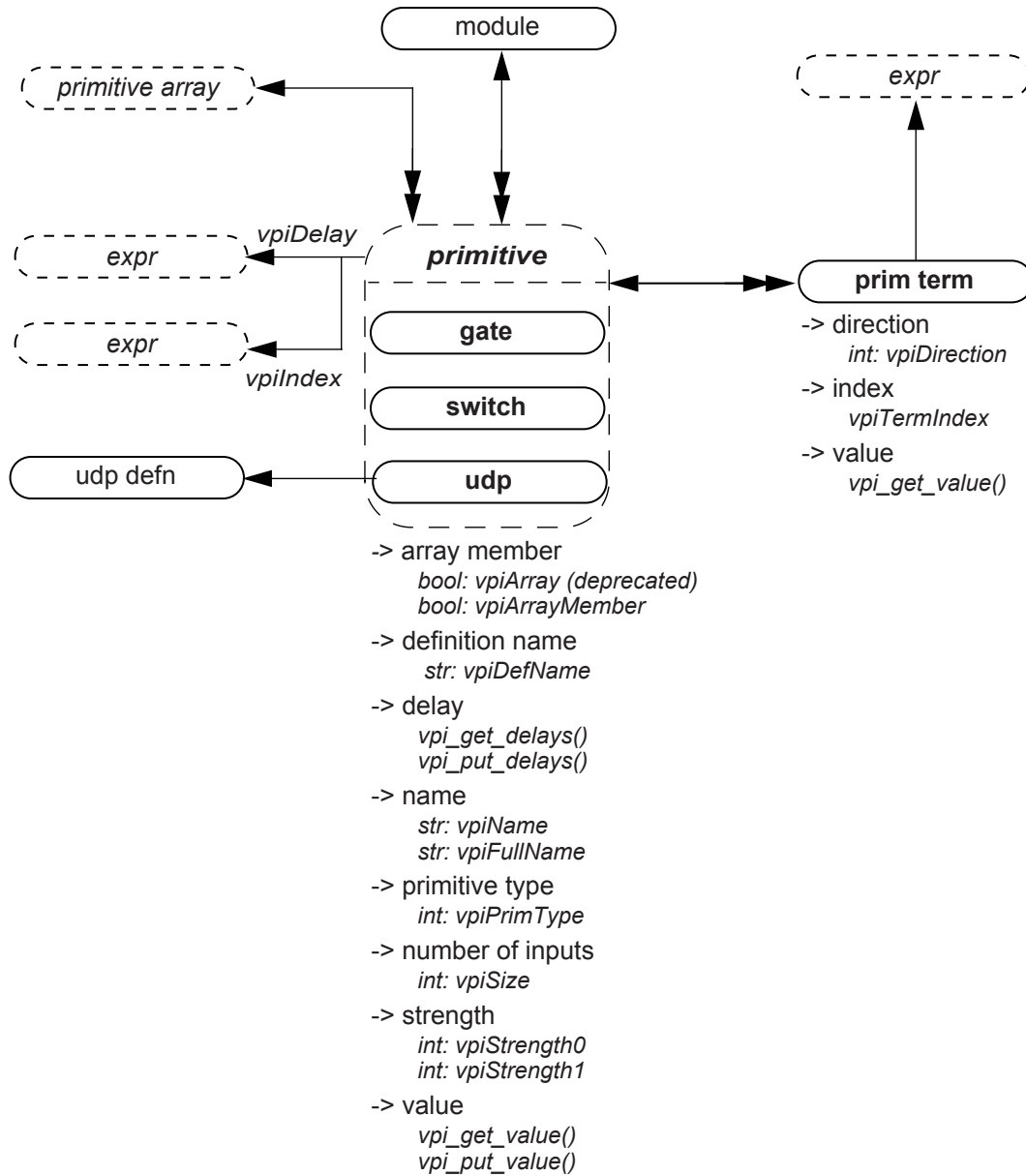

Details:

- 1) **vpiSize** shall return the number of inputs.
- 2) For primitives, **vpi_put_value()** shall only be used with sequential UDP primitives.
- 3) **vpiTermIndex** can be used to determine the terminal order. The first terminal has a term index of zero.
- 4) If a primitive is an element within a primitive array, the **vpiIndex** transition is used to access the index within the array. If a primitive is not part of a primitive array, this transition shall return NULL.

37.32 UDP

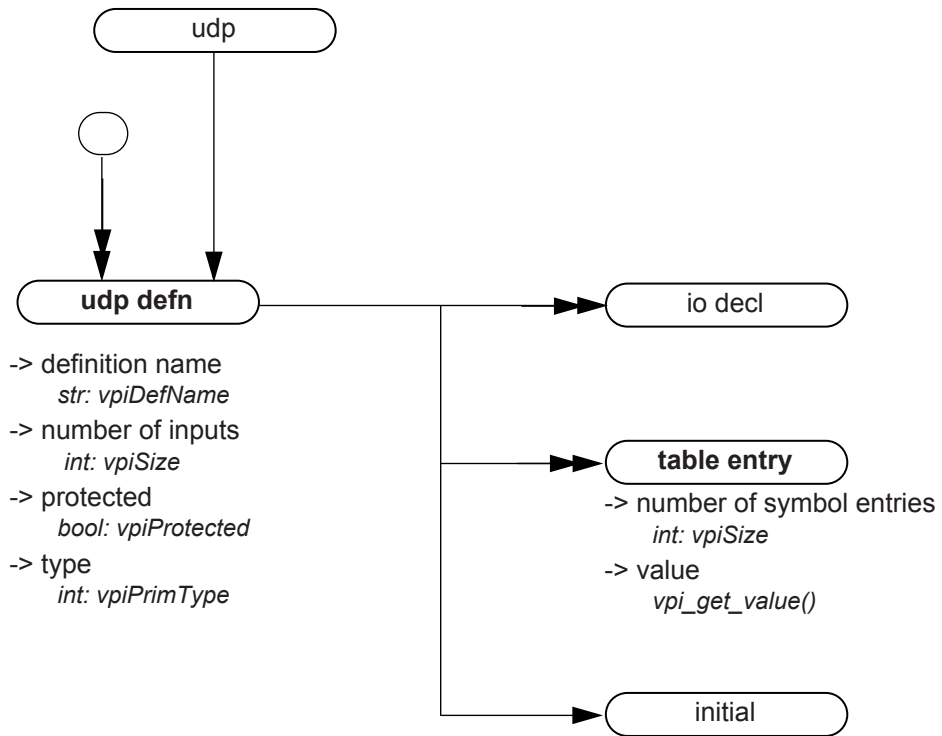

Details:

- 1) Only string (decompilation) and vector (ASCII values) shall be obtained for table entry objects using **vpi_get_value()**. Refer to the definition of **vpi_get_value()** for additional details.
- 2) **vpiPrimType** returns **vpiSeqPrim** for sequential UDPs and **vpiCombPrim** for combinational UDPs.

37.33 Intermodule path

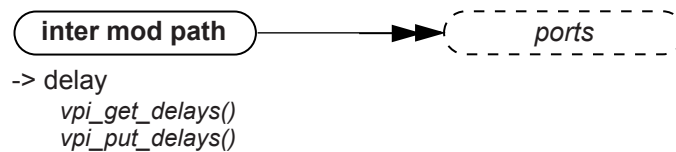

Details:

- 1) To get to an intermodule path, **vpi_handle_multi(vpiInterModPath, port1, port2)** can be used.

37.34 Constraint expression

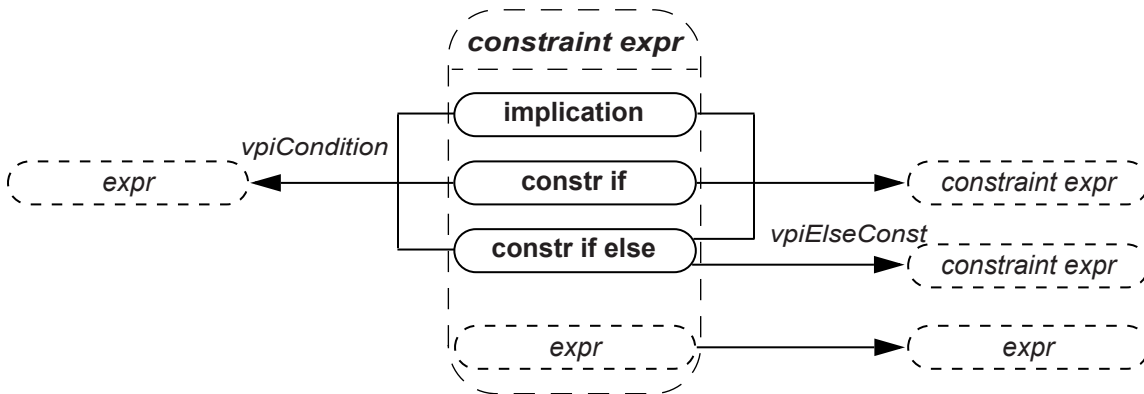

37.35 Module path, path term

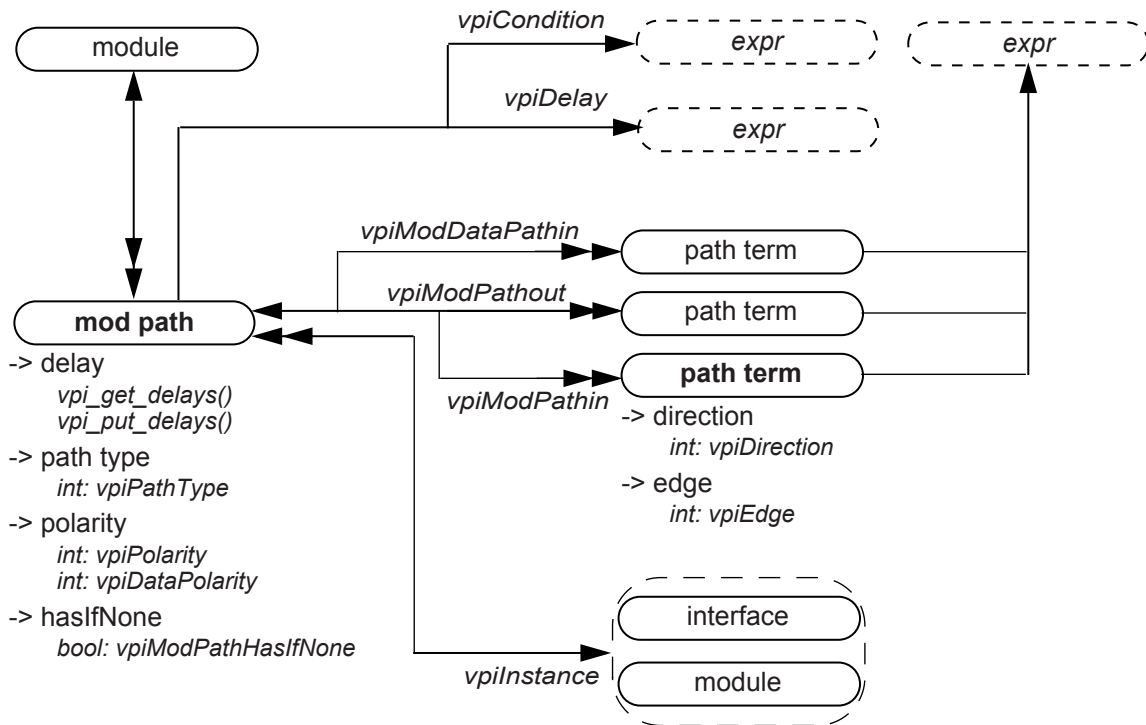

Details:

- 1) Specify blocks can occur in both modules and interfaces. For backwards compatibility the **vpiModule** relation has been preserved; however this relation shall return NULL for **specify** blocks in interfaces. For new code, it is recommended that the **vpiInstance** relation be used instead.

37.36 Timing check

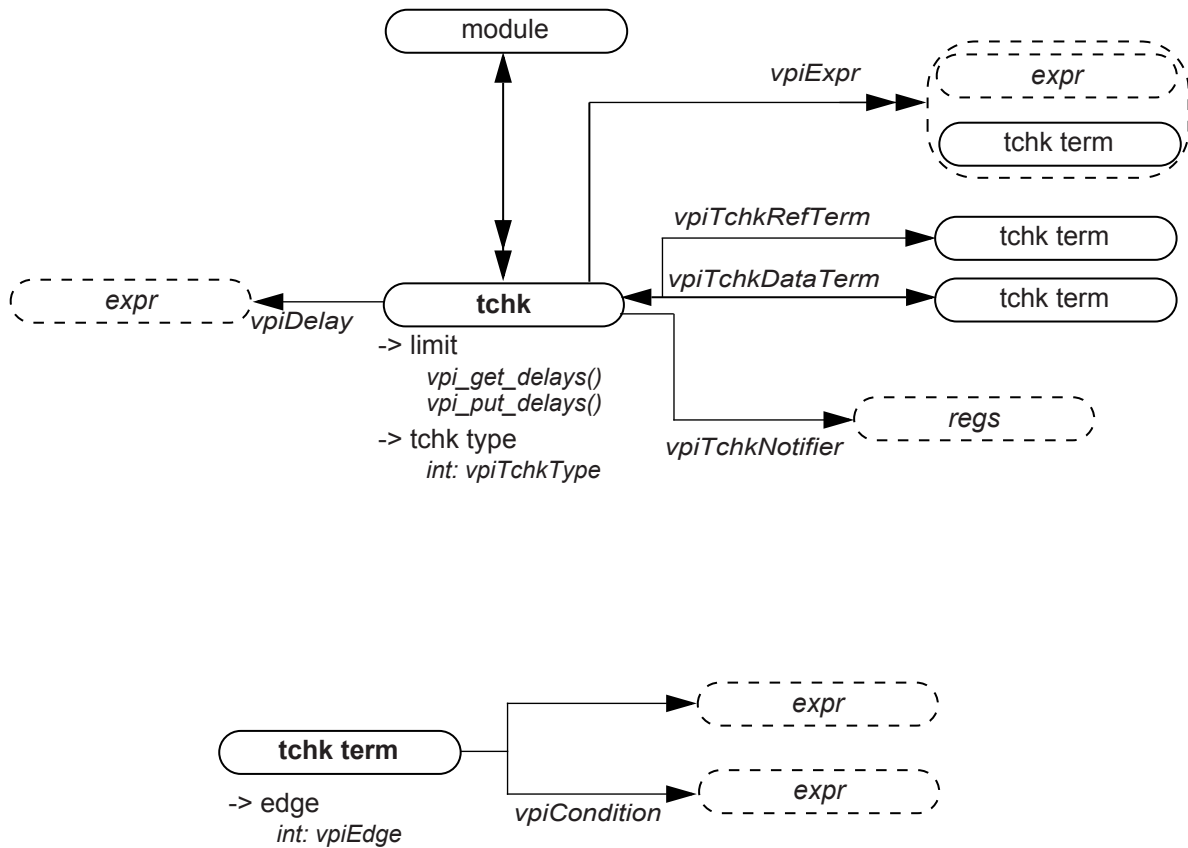

Details:

- 1) For the timing checks in [31.2](#) the relationship **vpiTchkRefTerm** shall denote the *reference_event* or *controlled_reference_event*, while **vpiTchkDataTerm** shall denote the *data_event*, if any.
- 2) When iterating over **vpiExpr** from a **tchk**, the handles returned for a *reference_event*, a *controlled_reference_event*, or a *data_event* shall have the type **vpiTchkTerm**. All other arguments shall have types matching the expression.

37.37 Task and function declaration

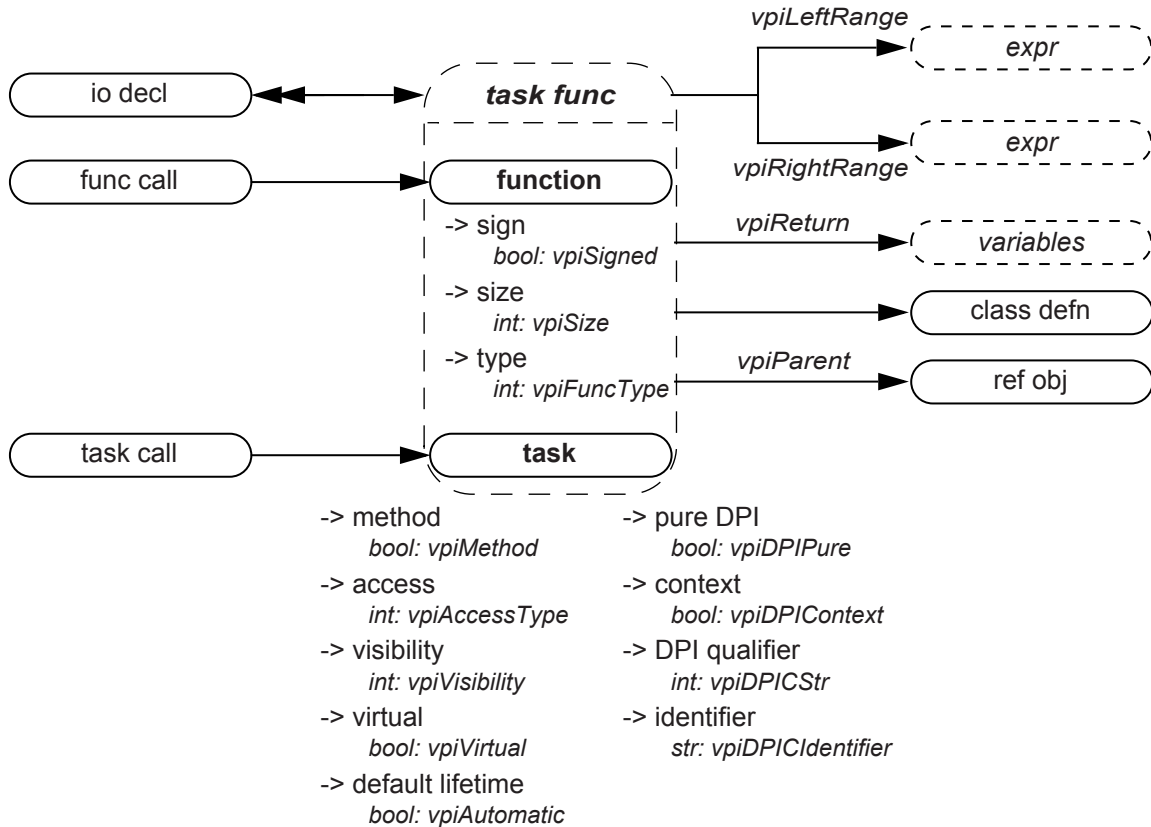

Details:

- 1) A SystemVerilog function shall contain an object with the same name, size, and type as the function. This object shall be used to capture the return value for this function.
- 2) For function where return type is a user-defined type, **vpi_handle(vpiReturn, function_handle)** shall return the implicit variable handle representing the return of the function from which the user can get the details of that user-defined type.
- 3) **vpiReturn** shall always return a `var` object, even for simple returns.
- 4) **vpiVisibility** denotes the visibility (**local**, **protected**, or default) of a task or function that is a class member (a method). **vpiVisibility** shall return **vpiPublicVis** for a class member that is not local or protected, or for a task or function that is not a class member.
- 5) **vpiFullName** of a task or function declared inside a package or class defn shall begin with the full name of the package or class defn followed by “: :” and immediately followed with the name of the task or function.
- 6) **vpiAccessType** shall return **vpiDPIExportAcc** for "DPI" and "DPI-C" export functions/tasks, and shall return **vpiDPIImportAcc** for "DPI" and "DPI-C" import functions/tasks.
- 7) **vpiDPIPure** shall return TRUE for pure "DPI" and "DPI-C" import functions.
- 8) **vpiDPIContext** shall return TRUE for context import "DPI" and "DPI-C", functions/tasks.
- 9) **vpiDPIQualifier** shall return **vpiDPI** for a "DPI" function/task, and **vpiDPIC** for a "DPI-C" function/task.
- 10) **vpiDPIIdentifier** shall return a string corresponding to the C linkage name for the "DPI"/"DPI-C" function/task.
- 11) For details on lifetime and memory allocation properties, see [37.3.7](#).

- 12) If the **vpiSize** of the **vpiReturn** variable is defined (see 37.17, detail 9) and can be determined without evaluating the function, **vpiSize** for the function shall return the same value as **vpiSize** for the **vpiReturn** variable. For a void function, **vpiSize** shall return 0. For all other cases the behavior of **vpiSize** is undefined.

37.38 Task and function call

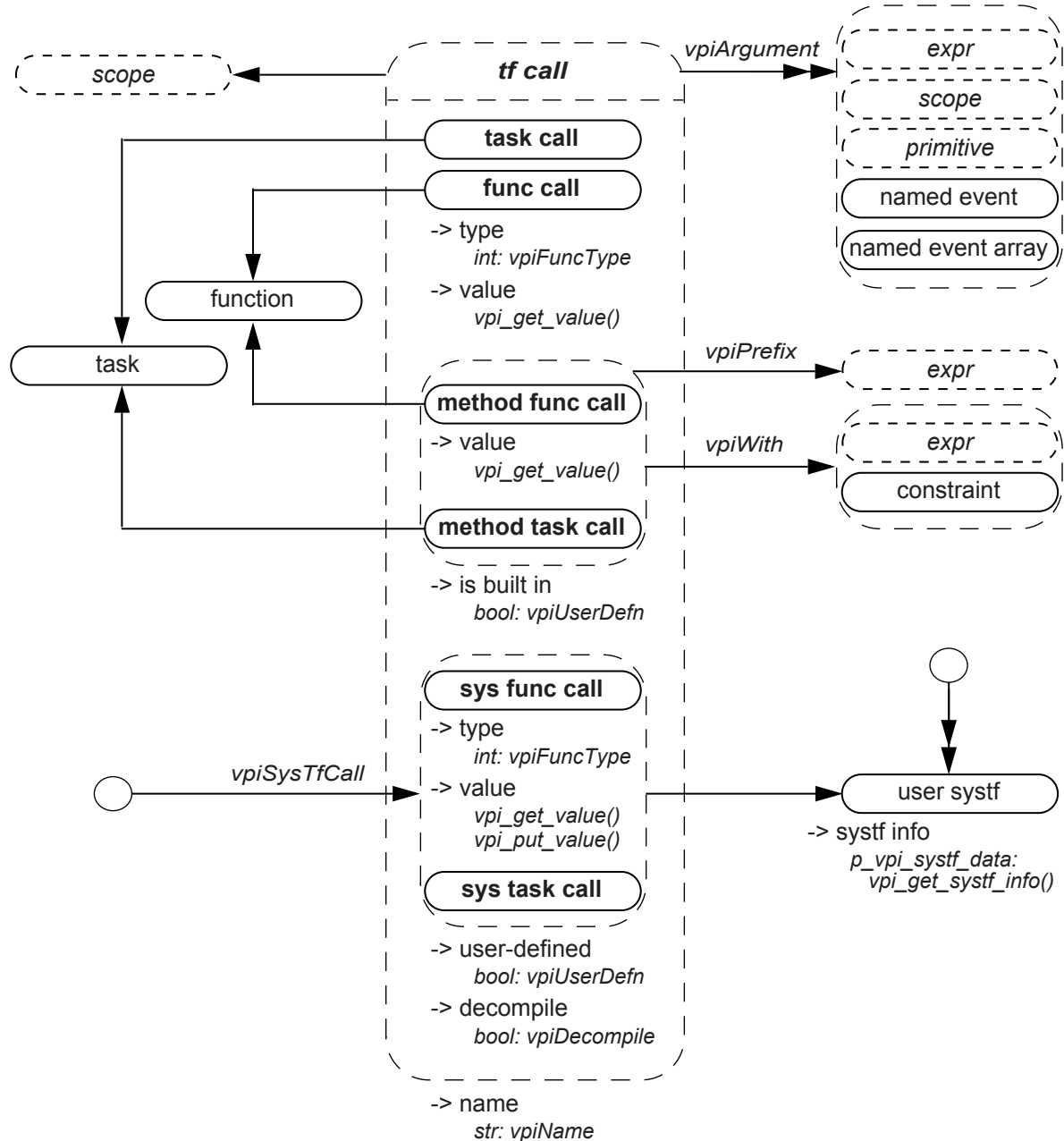

Details:

- 1) The **vpiWith** relation is only available for randomize methods (see 18.7) and for array locator methods (see 7.12.1).
- 2) For methods (method func call, method task call), the **vpiPrefix** relation shall return the object to which the method is being applied. For example, for the class method invocation

```
packet.send();
```

the prefix for the “send” method is the class var “packet”.

- 3) The system task or function that invoked an application shall be accessed with **vpi_handle(vpiSysTfCall, NULL)**.
- 4) **vpi_get_value()** shall return the current value of the system function.
- 5) If the **vpiUserDefn** property of a system task or function call is true, then the properties of the corresponding systf object shall be obtained via **vpi_get_systf_info()**.
- 6) All user-defined system tasks or functions shall be retrieved using **vpi_iterate()**, with **vpiUserSystf** as the type argument, and a NULL reference argument.
- 7) The simulator shall not evaluate arguments to system tasks or functions when calling those tasks or functions (36.4). Effectively, the value of any argument expression, or of any operand or argument of the expression, is not known until an application asks for it using **vpi_get_value()** (38.15), a **cbValueChange** callback (38.36.1), or other equivalent operation. If no application asks for the value of the argument, it is never evaluated.
- 8) An empty (omitted) argument (see 21.2.1) shall be represented as an expression with a **vpiType** of **vpiOperation** and a **vpiOpType** of **vpiNullOp**. An argument consisting of the special value **null** shall be represented as an expression with a **vpiType** of **vpiConstant** and a **vpiConstType** of **vpiNullConst**.

Example:

```
logic my_var;  
$my_task(my_var, "", , null, );
```

In the call to the user-defined system task `$my_task()`, `my_var` is an ordinary argument of type **vpiLogicVar**. The second argument, an empty string (but not an empty argument), is a **vpiConstant** for which the **vpiConstType** is **vpiStringConst**. The third and fifth arguments are empty arguments, while the fourth argument is a **vpiConstant** with a **vpiConstType** of **vpiNullConst**. VPI shall represent the third and fifth arguments as **vpiOperations** with a **vpiOpType** of **vpiNullOp**.

- 9) The property **vpiDecompile** shall return a string with a functionally equivalent system task or function call to what was in the original source code. The arguments shall be decompiled using the same manner as any expression is decompiled. See 37.55 for a description of expression decompilation.
- 10) System task and function calls that are protected shall allow iteration over the **vpiArgument** relationship.
- 11) For a built-in method func call, **vpiFunction** shall return NULL, while **vpiTask** shall return NULL for a built-in method task call.

37.39 Frames

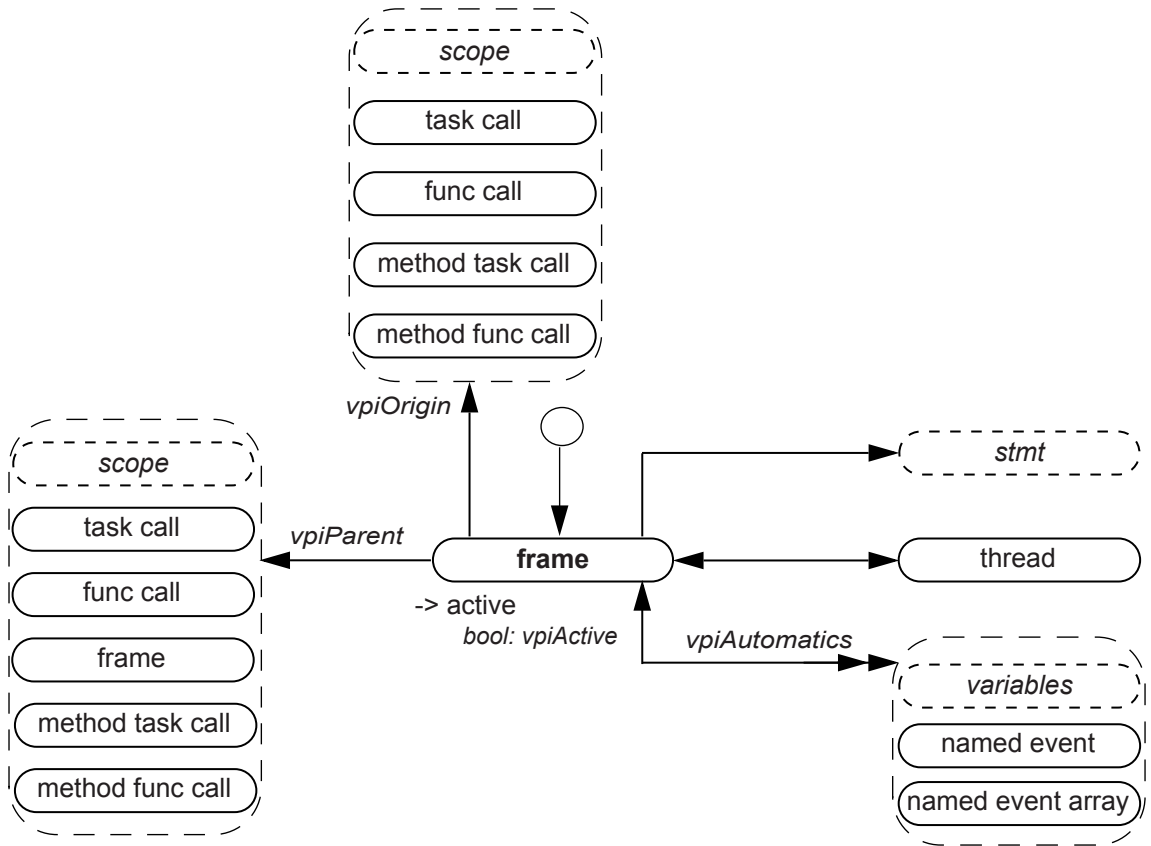

Details:

- 1) Frames correspond to the set of automatic variables declared in a given task or function.
- 2) It shall be illegal to place value change callbacks on automatic variables.
- 3) It shall be illegal to put a value with a delay on automatic variables.
- 4) There is at most only one active frame at any time in a given thread. To get a handle to the currently active frame, use `vpi_handle(vpiFrame, NULL)`. The frame to stmt transition shall return the currently active statement within the frame.
- 5) The frame object model is not backwards compatible with IEEE Std 1364-2005.
- 6) For details on frame specific callbacks, see [38.36.1](#).

37.40 Threads

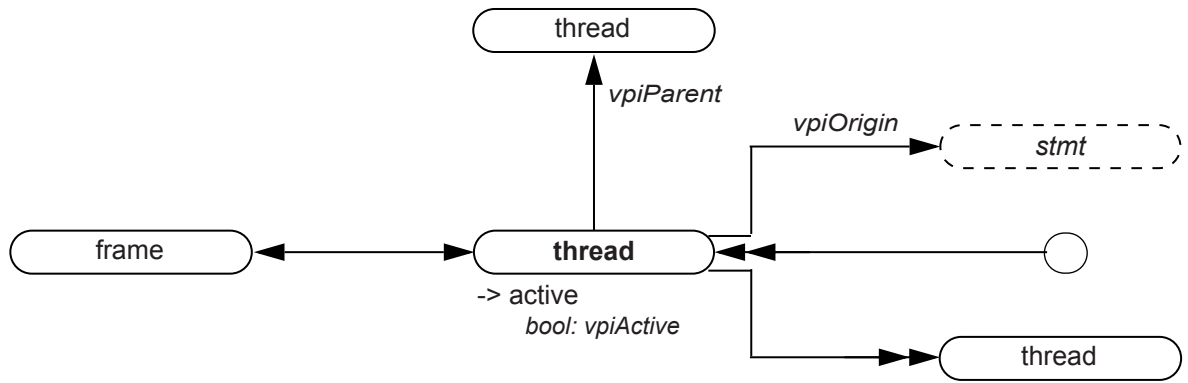

Details:

- 1) A thread is a SystemVerilog process such as an **always** procedure or a branch of a **fork** construct. As a thread works its way down a call chain of tasks and/or functions, a new frame is activated as each new task or function is entered.
- 2) For details on thread specific callbacks, see [38.36.1](#).

37.41 Delay terminals

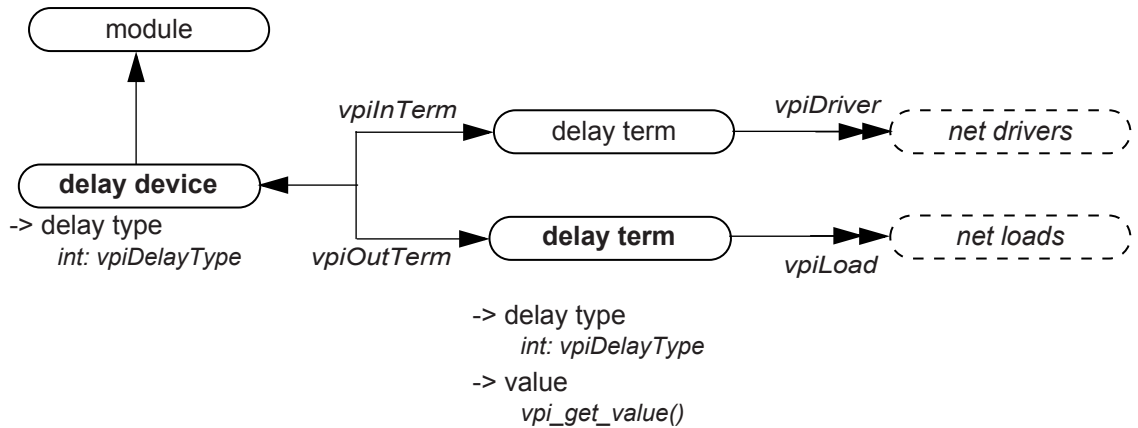

Details:

- 1) The value of the input delay term shall change before the delay associated with the delay device.
- 2) The value of the output delay term shall not change until after the delay has occurred.

37.42 Net drivers and loads

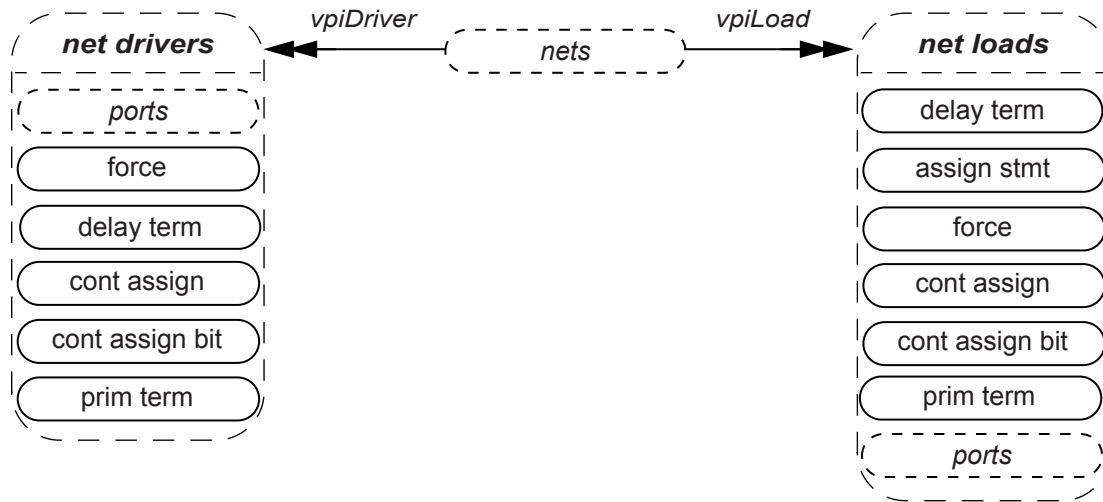

Details:

- 1) Complex expressions on input ports which are not concatenations shall be considered a load for a net. Iterating on loads for *trinet* in the following example will cause the fourth port of *ram* to be a load:

```
module my_module;
    tri trinet;
    ram r0 (a, write, read, !trinet);
endmodule
```

Access to the complex expression shall be available using `vpi_handle(vpiHighConn, portH)` where `portH` is the handle to the port returned when iterating on loads.

37.43 Continuous assignment

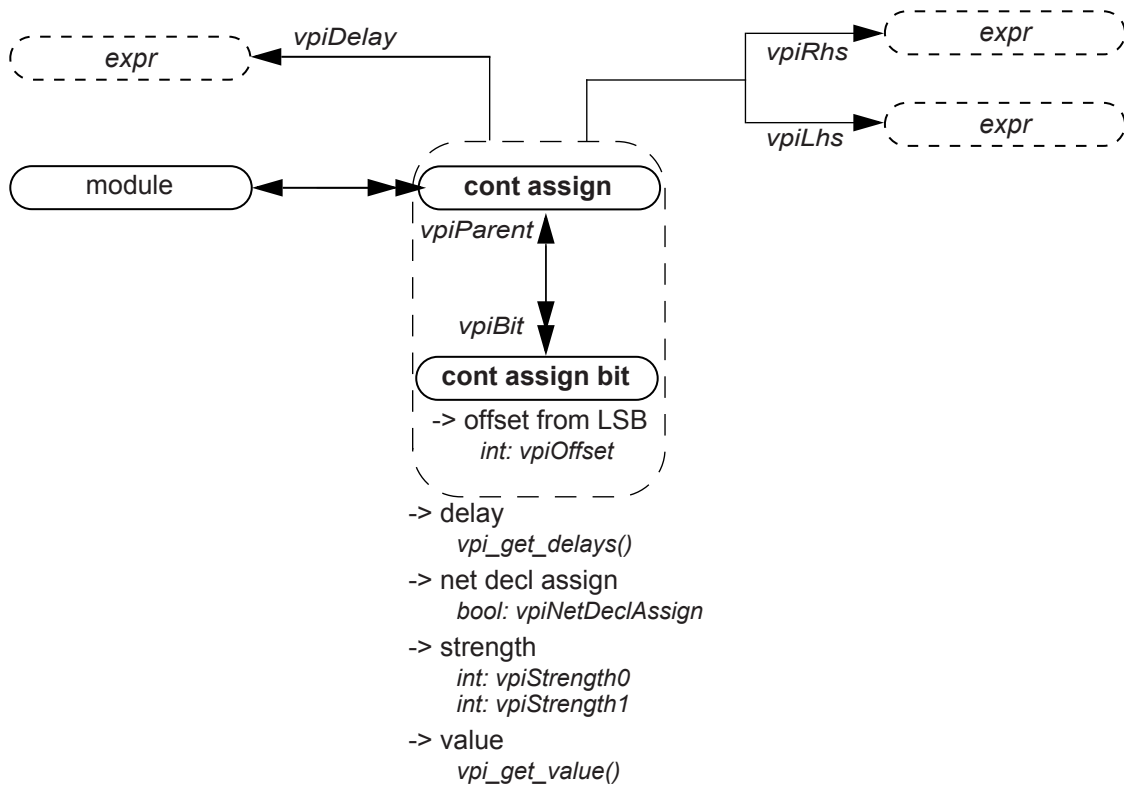

Details:

- 1) The size of a cont assign bit is always scalar.
- 2) Callbacks for value changes can be placed onto cont assign or a cont assign bit.
- 3) **vpiOffset** shall return zero for the least significant bit.

37.44 Clocking block

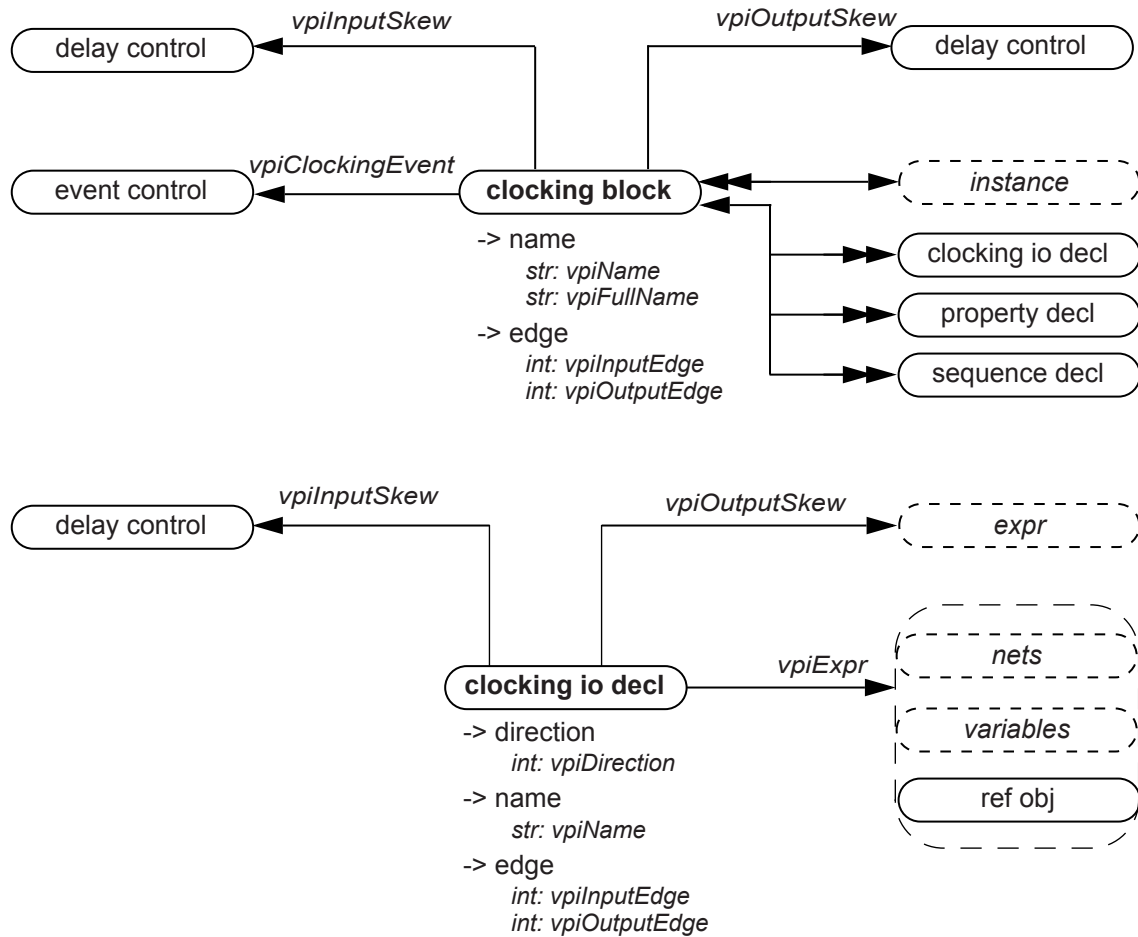

Details:

- 1) The methods, **vpiInputSkew** and **vpiOutputSkew**, and properties **vpiInputEdge** and **vpiOutputEdge**, on the `clocking block` apply to the default constructs. The same methods and properties on the `clocking io decl` apply to the `clocking io decl` itself.
- 2) **vpiExpr** shall return the expression or ref obj referenced by the `clocking io decl`. Consider input `enable = top.mem1.enable`. Here, “enable” is represented by a `clocking io decl`, and the **vpiExpr** relation returns a handle to “`top.mem1.enable`”.

37.45 Assertion

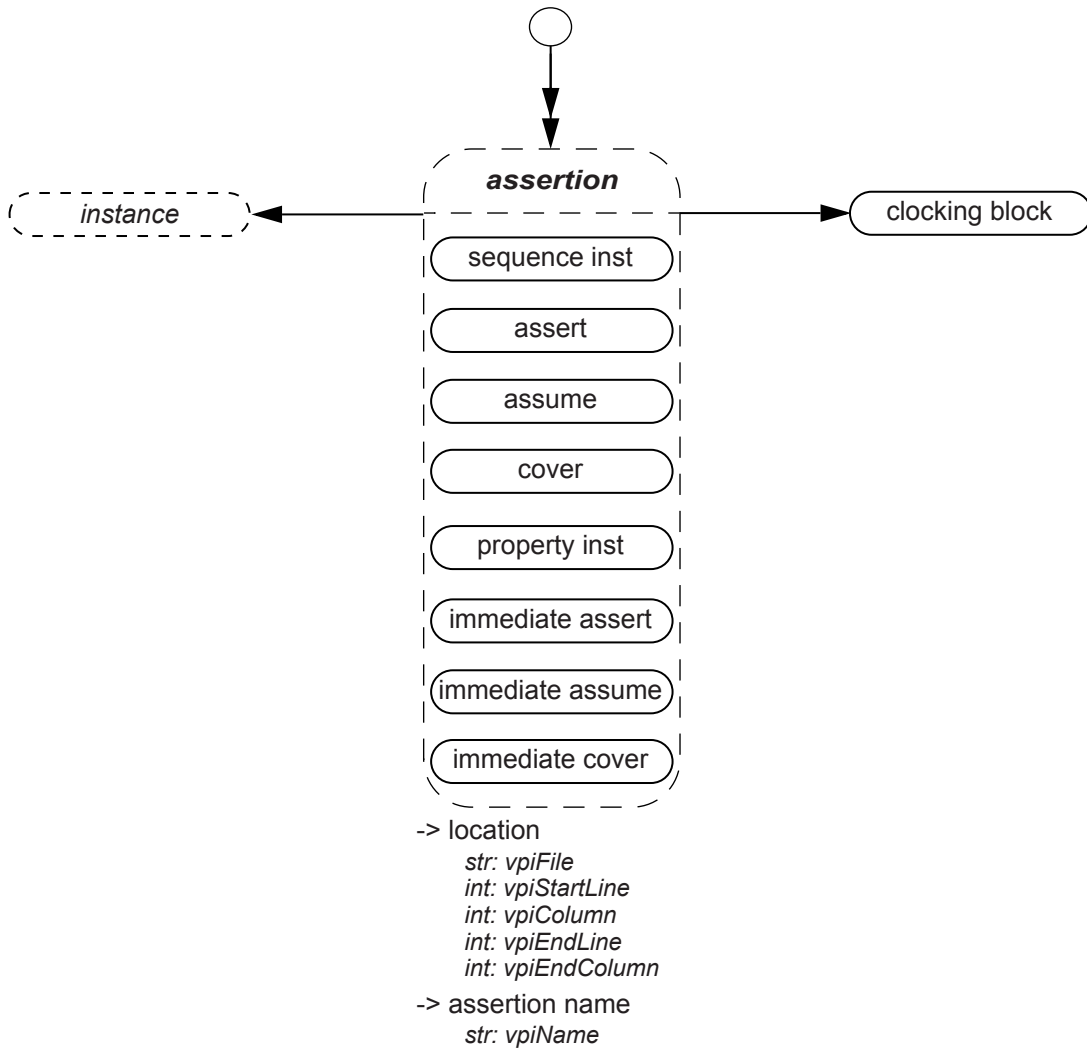

Details:

- 1) For details on using VPI to obtain static and dynamic assertion information as well as assertion callbacks and control see [Clause 39](#).
- 2) For details on using VPI to obtain assertion coverage see [40.5.3](#).

37.46 Concurrent assertions

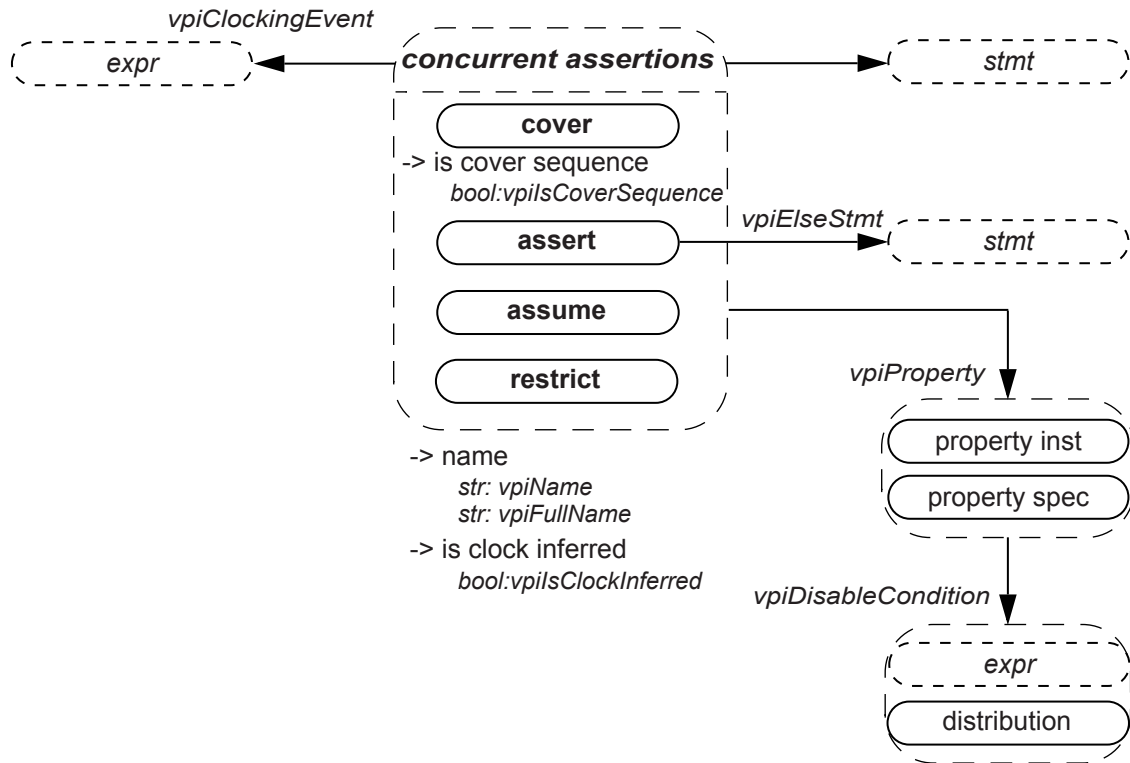

Details:

- 1) Clocking event is always the actual clocking event on which the assertion is being evaluated, regardless of whether this is explicit or implicit (inferred).
- 2) The **restrict property** statement has no pass and no fail action statement. Also, it is not simulated and hence generates no run-time information.

37.47 Property declaration

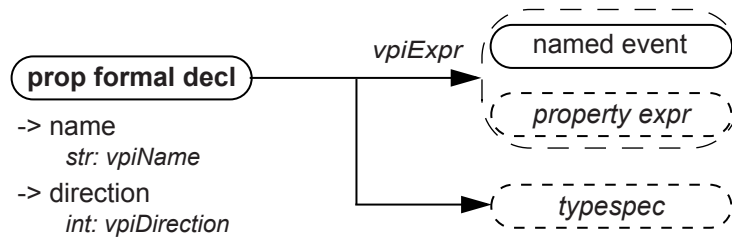
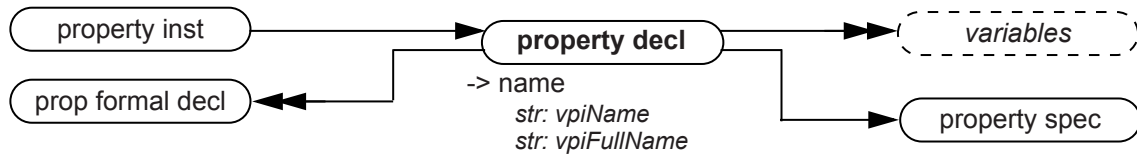

Details:

- 1) The **vpiPropFormalDecl** iterator shall return the property declaration arguments in the order that the formals for the property are declared.
- 2) The **vpiTypeSpec** relation shall return NULL if the formal is untyped.
- 3) If the formal has an initialization expression, the expression can be obtained using the **vpiExpr** relation.
- 4) **vpiDirection** returns **vpiNoDirection** if the formal argument is not a local variable argument. Otherwise, **vpiDirection** returns **vpiInput**.

37.48 Property specification

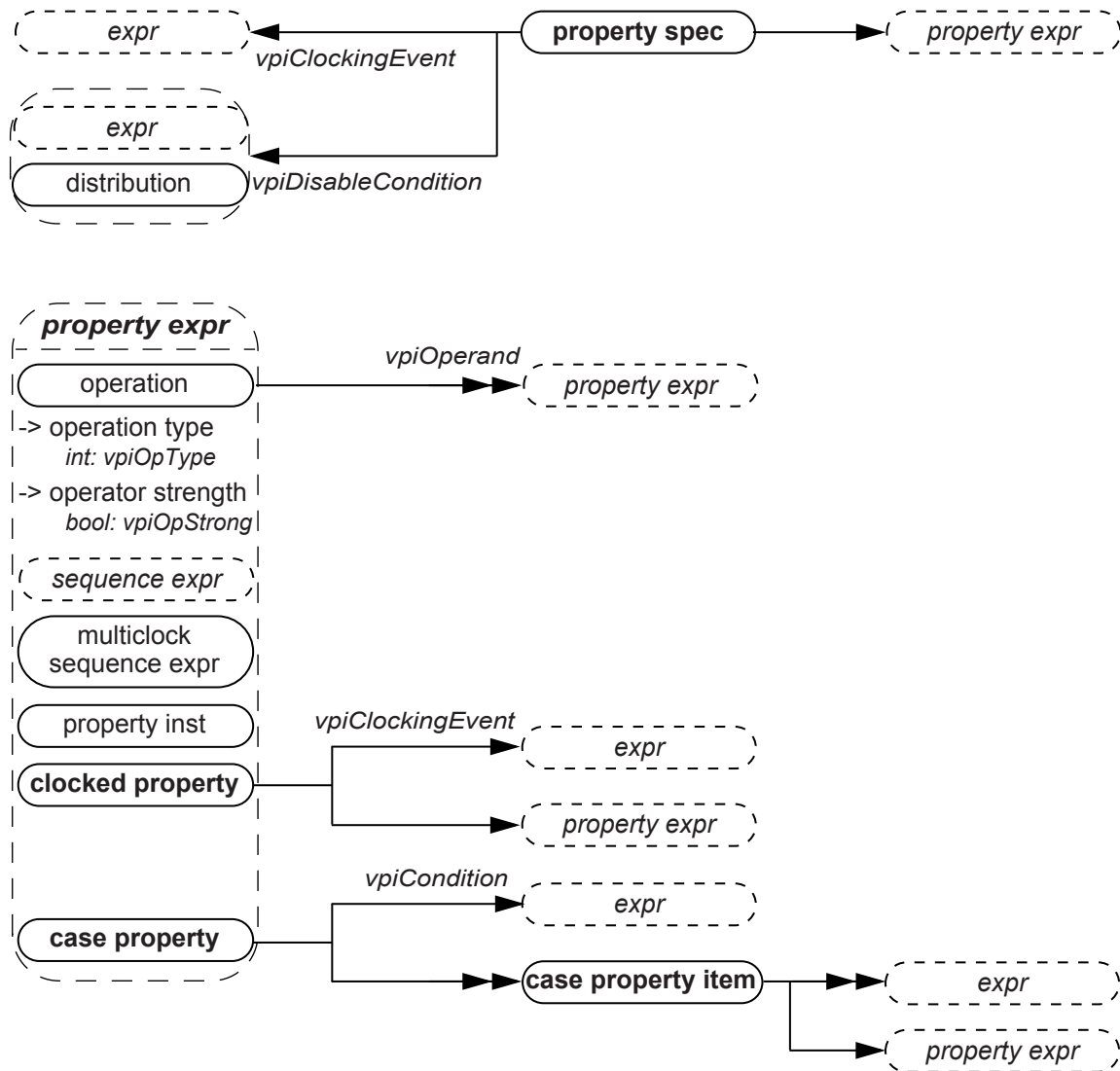

Details:

- 1) Variables are declarations of property variables. The value of these variables cannot be accessed.
- 2) Within the context of a property expr, **vpiOpType** can be any one of **vpiAcceptOnOp**, **vpiAlwaysOp**, **vpiCompAndOp**, **vpiCompOrOp**, **vpiEventuallyOp**, **vpiIfElseOp**, **vpiIfOp**, **vpiIfffOp**, **vpiImpliesOp**, **vpiNexttimeOp**, **vpiNonOverlapFollowedByOp**, **vpiNonOverlapFollowedByOp**, **vpiNonOverlapImplyOp**, **vpiNotOp**, **vpiOverlapFollowedByOp**, **vpiOverlapImplyOp**, **vpiRejectOnOp**, **vpiSyncAcceptOnOp**, **vpiSyncRejectOnOp**, **vpiUntilOp**, **vpiUntilWithOp**.

Operands to these operations shall be provided in the same order as shown in the BNF, with the following exceptions:

- **vpiNexttimeOp**: Arguments shall be: property, constant. constant shall only be given if different from 1.
 - **vpiAlwaysOp** and **vpiEventuallyOp**: Arguments shall be: property, left range, right range.
- 3) **vpiOpStrong** is valid only for operations **vpiNexttimeOp**, **vpiAlwaysOp**, **vpiEventuallyOp**, **vpiUntilOp**, **vpiUntilWithOp**, and for sequence expression. **vpiOpStrong** shall return TRUE to indicate the strong version of the corresponding operator.
 - 4) The case property item shall group all case conditions that branch to the same property statement.
 - 5) **vpi_iterate()** shall return NULL for the default case item because there is no expression with the default case.

37.49 Sequence declaration

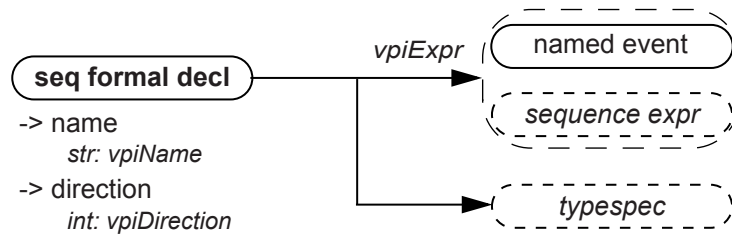
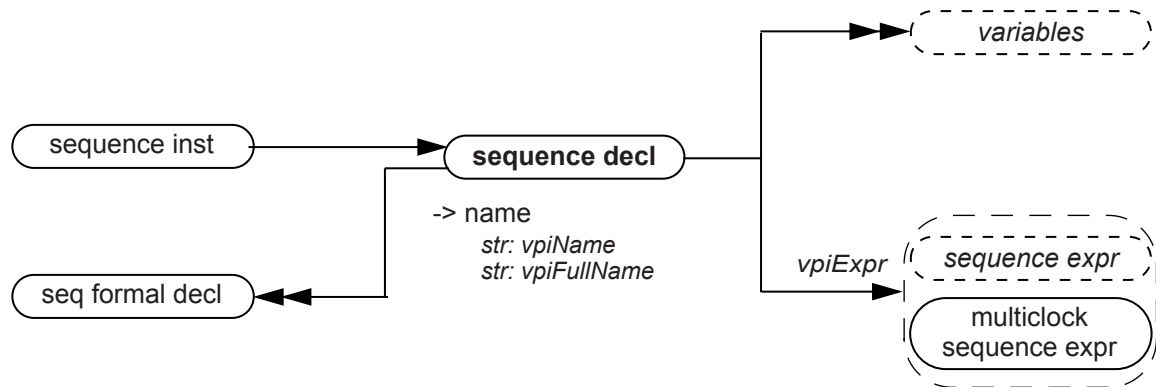

Details:

- 1) The **vpiSeqFormalDecl** iterator shall return the sequence declaration arguments in the order that the formals for the sequence are declared.
- 2) The **vpiTypeSpec** relation shall return NULL if the formal is untyped.
- 3) If the formal has an initialization expression, the expression can be obtained using the **vpiExpr** relation.
- 4) **vpiDirection** returns **vpiNoDirection** if the formal argument is not a local variable argument. Otherwise, **vpiDirection** returns either **vpiInput**, **vpiOutput**, or **vpiInout**.

37.50 Sequence expression

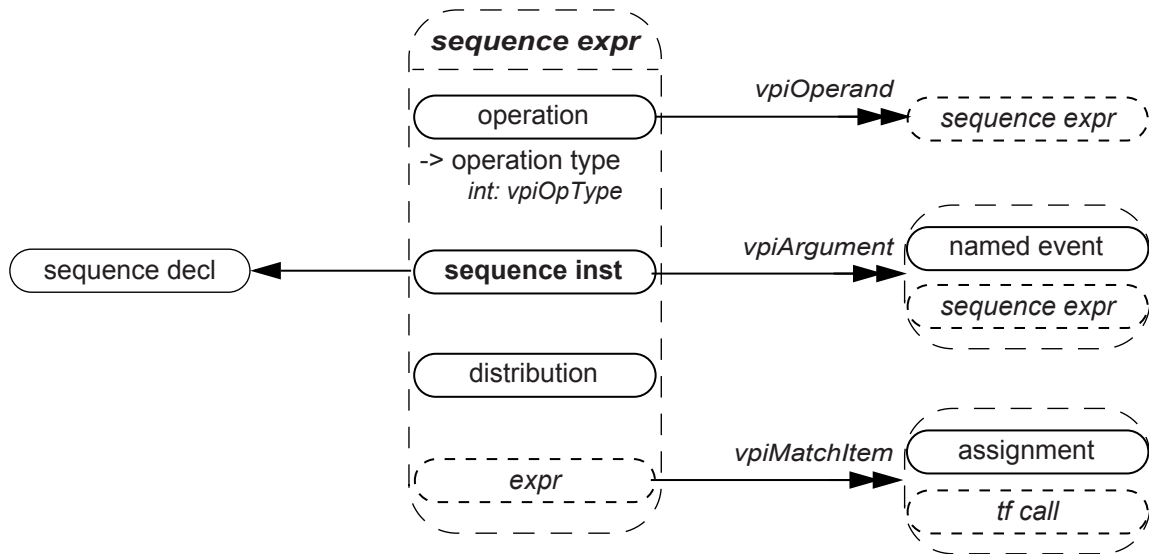

Details:

- 1) The **vpiArgument** iterator shall return the sequence instance arguments in the order that the formals for the sequence are declared, so that the correspondence between each argument and its respective formal can be made. If a formal has a default value, that value shall appear as the argument should the instantiation not provide a value for that argument.
- 2) Within a sequence expression, **vpiOpType** can be any one of **vpiCompAndOp**, **vpiIntersectOp**, **vpiCompOr**, **vpiFirstMatchOp**, **vpiThroughoutOp**, **vpiWithinOp**, **vpiUnaryCycleDelayOp**, **vpiCycleDelayOp**, **vpiRepeatOp**, **vpiConsecutiveRepeatOp**, or **vpiGotoRepeatOp**.
- 3) For operations, the operands shall be provided in the same order as the operands appear in BNF, with the following exceptions:
 - **vpiUnaryCycleDelayOp**: Arguments shall be: sequence, left range, right range. Right range shall only be given if different from left range.
 - **vpiCycleDelayOp**: argument shall be: LHS sequence, rhs sequence, left range, right range. Right range shall only be provided if different than left range.
 - All the repeat operators: The first argument shall be the sequence being repeated, and the next argument shall be the left repeat bound, followed by the right repeat bound. The right repeat bound shall only be provided if different from left repeat bound.

```
and, intersect, or,
first_match,
throughout, within,
##,
[*], [=], [->]
```

37.51 Immediate assertions

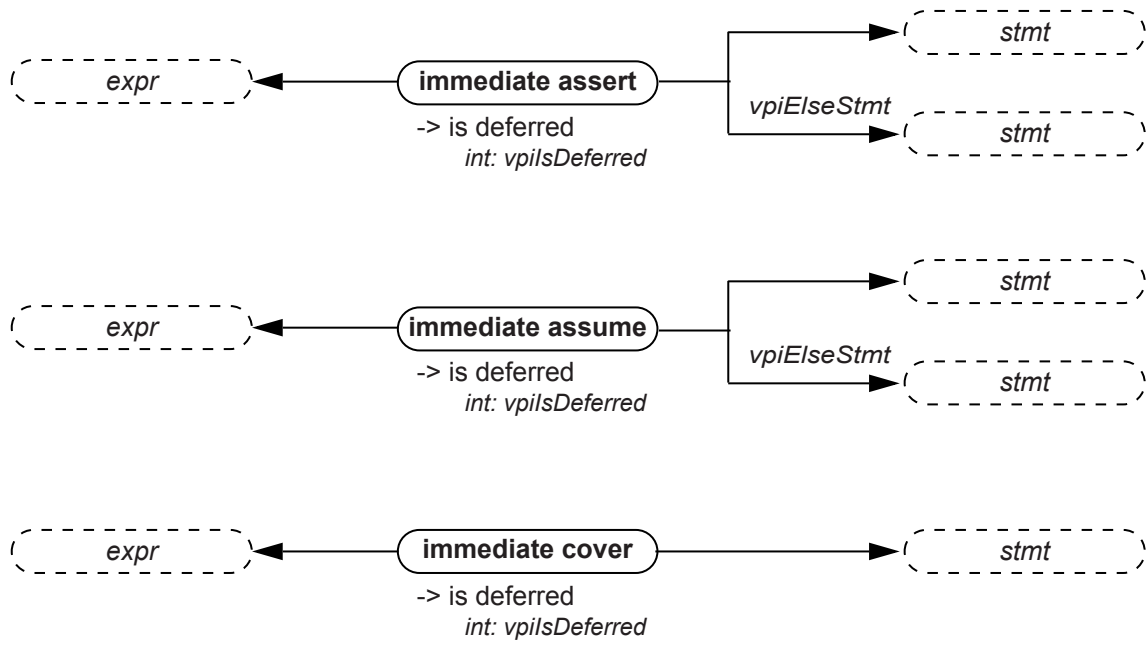

37.52 Multiclock sequence expression

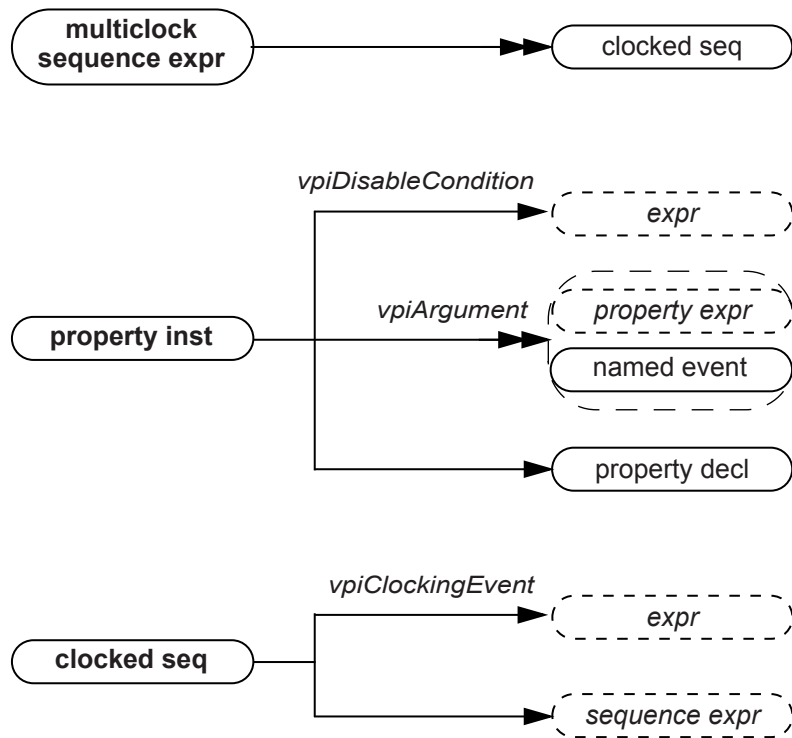

Details:

- 1) The **vpiArgument** iterator shall return the property instance arguments in the order that the formals for the property are declared, so that the correspondence between each argument and its respective formal can be made. If a formal has a default value, that value shall appear as the argument should the instantiation not provide a value for that argument.

37.53 Let

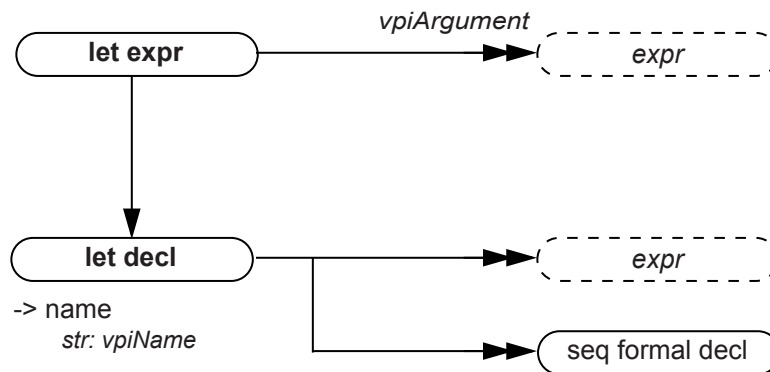

Details:

- 2) The **vpiArgument** iterator shall return the let expression arguments in the order that the formals for the let are declared, so that the correspondence between each argument and its respective formal can be made. If a formal has a default value, that value shall appear as the argument should the instantiation not provide a value for that argument.

37.54 Simple expressions

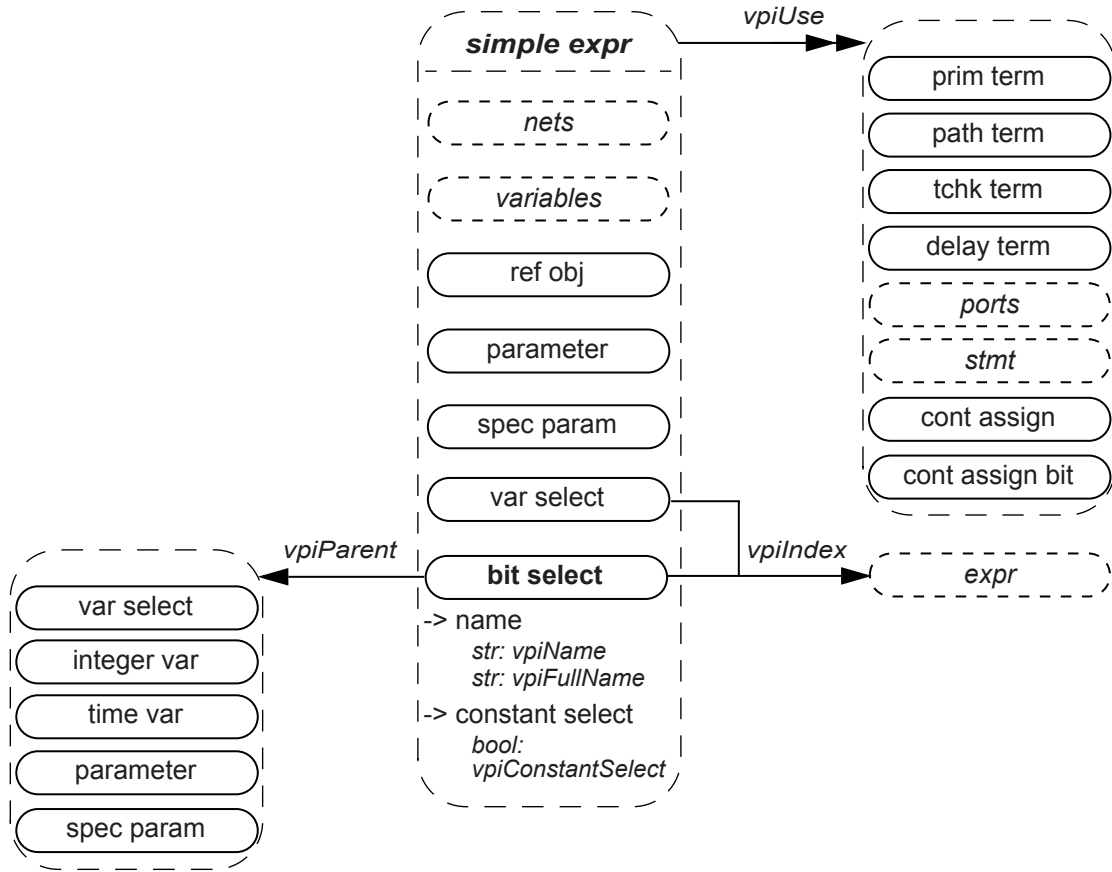

Details:

- 1) For vectors, the **vpiUse** relationship shall access any use of the vector or of the part-selects or bit-selects of the vector.
- 2) For bit-selects, the **vpiUse** relationship shall access any specific use of that bit, any use of the parent vector, and any part-select that contains that bit.
- 3) The property **vpiConstantSelect** shall return TRUE for a bit-select if
 - every associated index expression is an elaboration time constant expression, and
 - **vpiConstantSelect** returns TRUE for the parent of the bit-select.

Otherwise, **vpiConstantSelect** shall return FALSE.

NOTE—If **vpiConstantSelect** is TRUE, then if the handle refers to a valid underlying simulation object at the beginning of simulation (or at any point in the simulation), it refers to the same object at all points in the simulation. Moreover, if an index expression of the bit-select or of any of its parents is in or out of bounds at the beginning of simulation, it is in or out of bounds at all subsequent simulation times as well.

37.55 Expressions

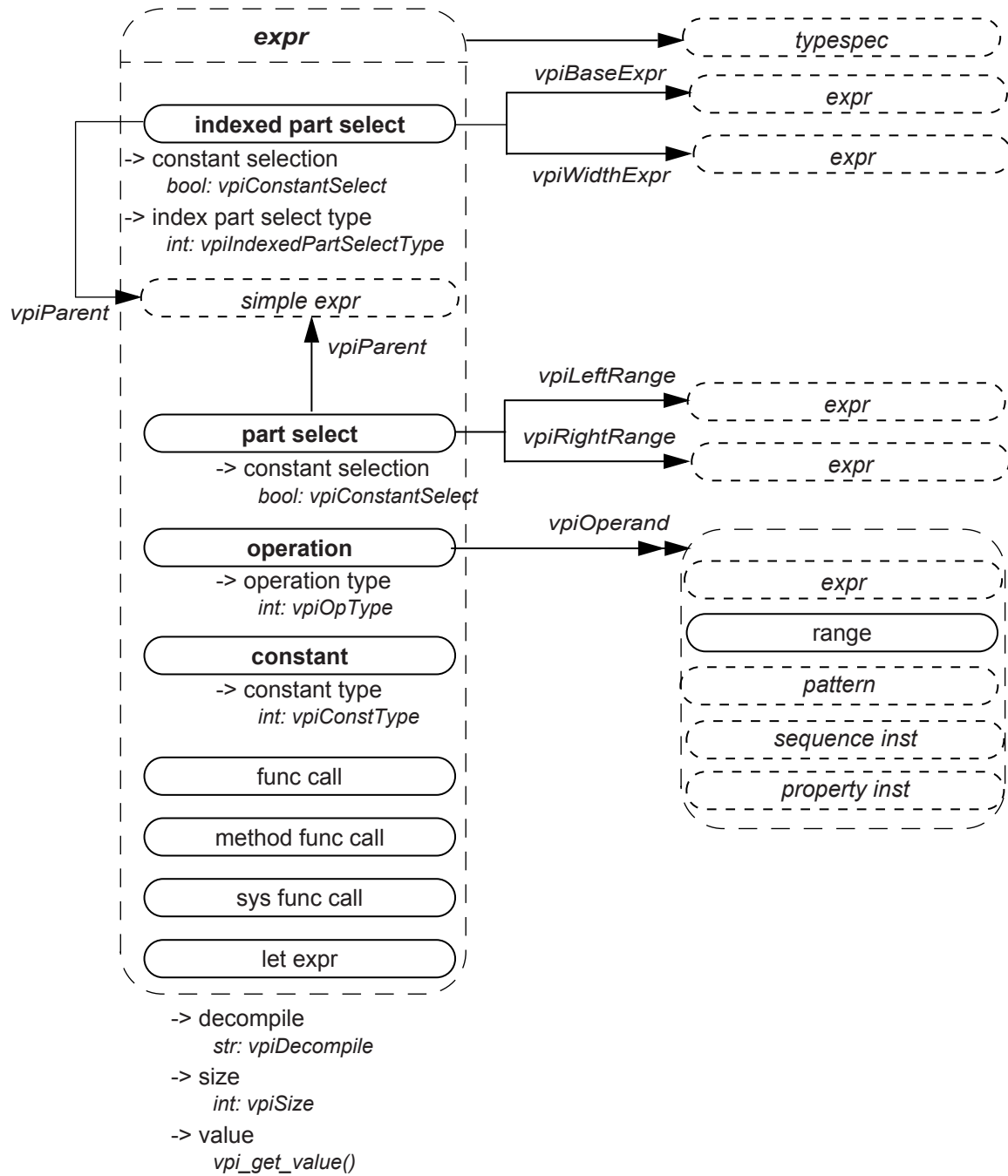

Details:

- 1) For an operator whose type is **vpiMultiConcatOp**, the first operand shall be the multiplier expression. The remaining operands shall be the expressions within the concatenation.
- 2) The property **vpiDecompile** shall return a string with a functionally equivalent expression to the original expression within the source code. Parentheses shall be added only to preserve precedence. Each operand and operator shall be separated by a single space character. No additional white space shall be added due to parentheses.

- 3) The cast operation, for which **vpiOpType** returns **vpiCastOp**, is represented as a unary operation, with its sole argument being the expression being cast, and the typespec of the cast expression being the type to which the argument is being cast.
- 4) The constant type **vpiUnboundedConst** represents the \$ value used in assertion ranges.
- 5) The one to one relation to typespec shall always be available for **vpiCastOp** operations, for simple expressions, and for **vpiAssignmentPatternOp** and **vpiMultiAssignmentPatternOp** expressions when the curly braces of the assignment pattern are prefixed by a data type name to form an assignment pattern expression. For other expressions, it is implementation dependent as to whether or not there is any associated typespec.
- 6) For an operation of type **vpiAssignmentPatternOp**, the operand iteration shall return the expressions as if the assignment pattern were written with the positional notation. Nesting of assignment patterns shall be preserved.

Example 1:

```
struct {
    int A;
    struct {
        logic B;
        real C;
    } BC1, BC2;
} ABC = '{BC1: '{1'b1, 1.0}, int: 0, BC2: '{default: 0}};
```

The assignment pattern that initializes the struct variable ABC uses member, type, and default keys. The **vpiOperand** traversal would represent this assignment pattern expression as:

```
'{0, '{1'b1, 1.0}, '{0, 0}}
```

or some other equivalent positional assignment pattern.

Example 2:

```
logic [2:0] varr [0:3] = '{3: 3'b1, default: 3'b0};
```

The assignment pattern that initializes the array variable varr uses index and default keys. The **vpiOperand** traversal would represent this assignment pattern as:

```
'{3'b0, 3'b0, 3'b0, 3'b1}
```

- 7) For an operator whose type is **vpiMultiAssignmentPatternOp**, the first operand shall be the multiplier expression. The remaining operands shall be the expressions within the assignment pattern.

Example:

```
bit unpackedbits [1:0];
initial unpackedbits = '{2 {y}} ; // same as '{y, y}
```

For the assignment pattern '{2 {y}}, the **vpiOpType** property shall return **vpiMultiAssignmentPatternOp**, and the first operand shall be the constant 2. The next operand shall represent the expression y.

- 8) Expressions which are protected shall permit access to the **vpiSize** property.
- 9) The property **vpiConstantSelect** shall return TRUE for a part-select or indexed part-select if
 - **vpiConstantSelect** returns TRUE for its parent, and
 - the parent is a packed or unpacked array with static bounds, and
 - each range expression in the part-select or indexed part-select is an elaboration time constant expression.

Otherwise, **vpiConstantSelect** shall return FALSE.

NOTE—If **vpiConstantSelect** is TRUE, then if the handle refers to a valid underlying simulation object at the beginning of simulation (or at any point in the simulation), it refers to the same object at all points in the simulation. Moreover, if any index expression of the part-select or indexed part-select or of any of its parents is in or out of bounds at the beginning of simulation, it is in or out of bounds at all subsequent simulation times as well.

- 10) For a part-select or indexed part-select, the **vpiParent** object shall correspond to the expression formed by removing the part-select range from the expression represented by the part-select or indexed part-select itself. For example, given the declaration

```
logic [0:3][7:0] r [1:4];
```

then the parents of various part-selects or indexed part-selects shall be as shown in [Table 37-1](#):

Table 37-1—Part-select parent expressions

part-select or indexed part-select expression	parent expression
<code>r[4][3][1:0]</code>	<code>r[4][3]</code>
<code>r[i+1][3][j+:2]</code>	<code>r[i+1][3]</code>
<code>r[0][j-:4]</code>	<code>r[0]</code>
<code>r[0:2]</code>	<code>r</code>

37.56 Atomic statement

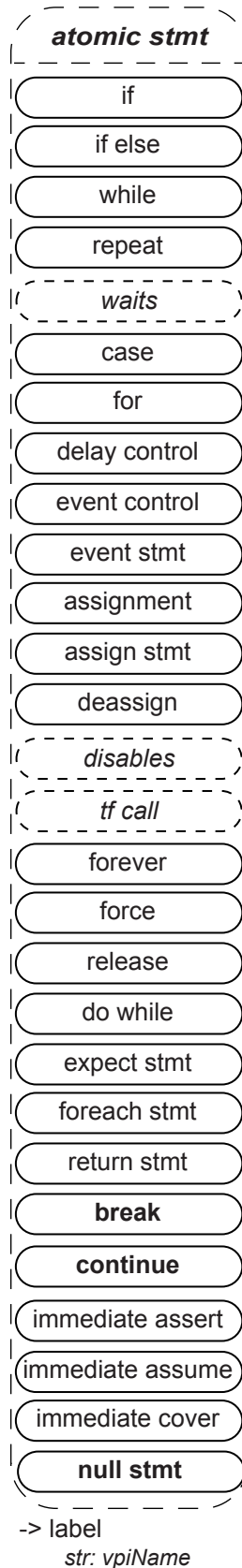

Details:

- 1) The **vpiName** property shall provide the statement label if one was given; otherwise, the name is NULL.

37.57 Event statement



37.58 Process

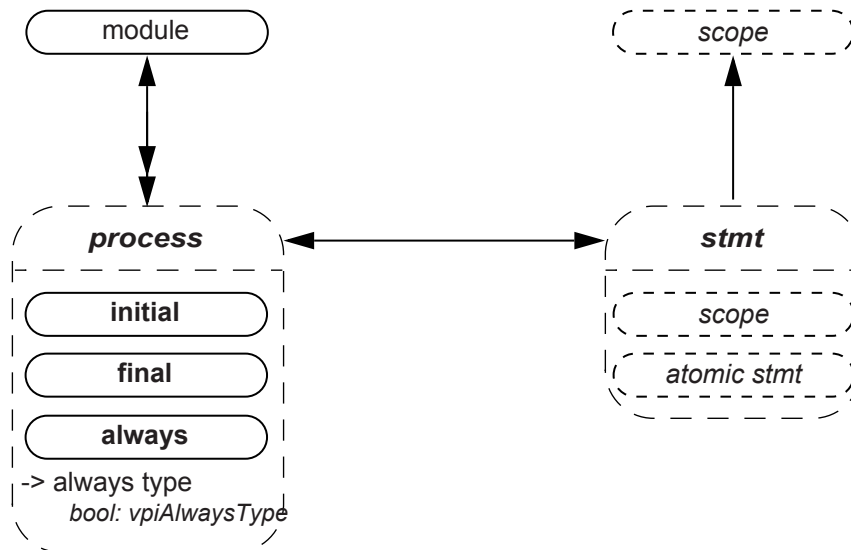

Details:

- 1) **vpiAlwaysType** can be one of **vpiAlways**, **vpiAlwaysComb**, **vpiAlwaysFF**, or **vpiAlwaysLatch**.

37.59 Assignment

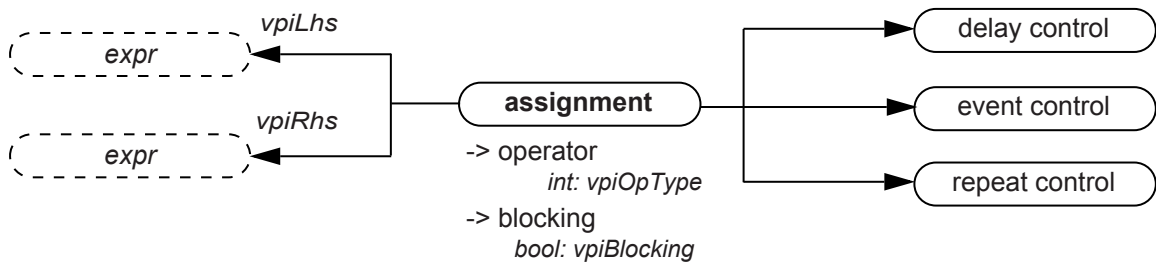

Details:

- 1) **vpiOpType** shall return **vpiAssignmentOp** for normal assignments (both blocking '=' and nonblocking '<=>'). For assignment operators, **vpiOpType** shall return a value that corresponds to the operator that is combined with the assignment as described in [11.4.1](#).

For example, the assignment

```
a += 2;
```

shall return **vpiAddOp** for the **vpiOpType** property.

37.60 Event control

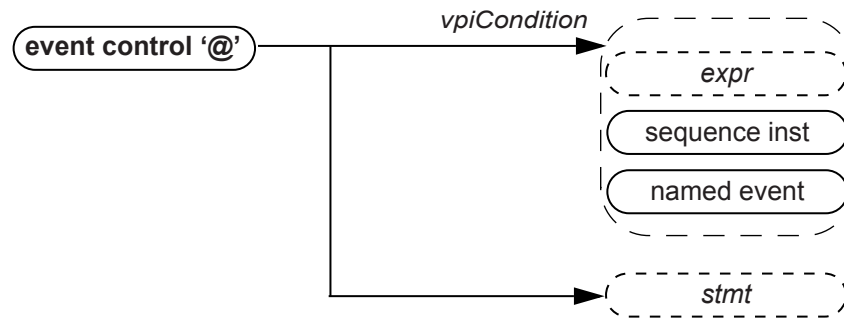

Details:

- 1) For event control associated with assignment, the statement shall always be NULL.

37.61 While, repeat

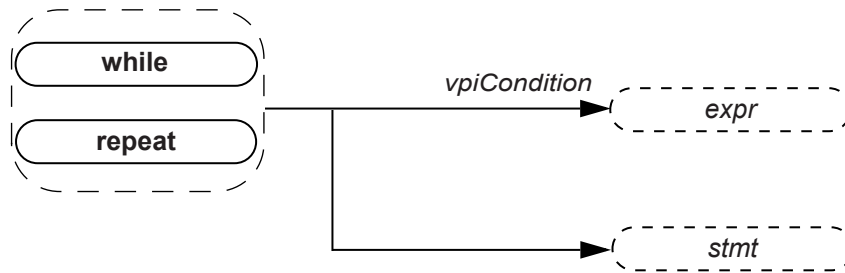

37.62 Waits

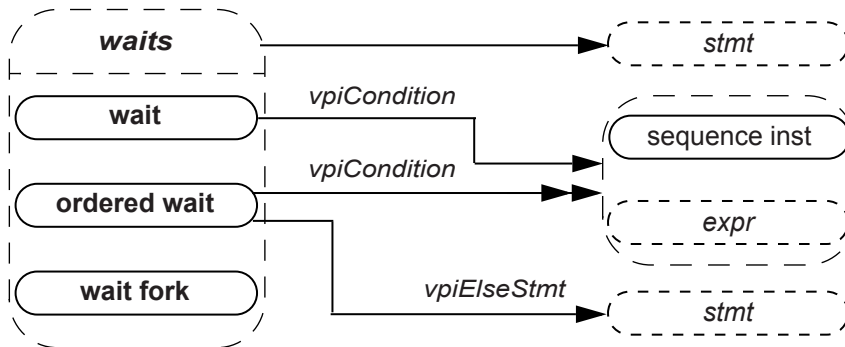

37.63 Delay control

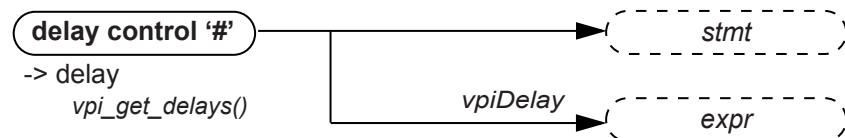

Details:

- 1) For delay control associated with assignment, the statement shall always be NULL.

37.64 Repeat control

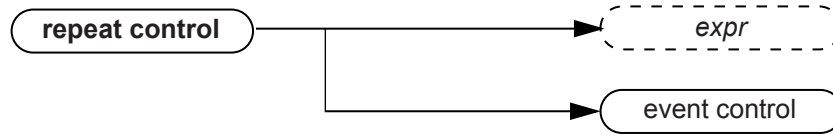

37.65 Forever

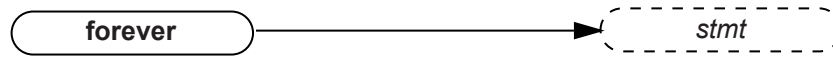

37.66 If, if-else

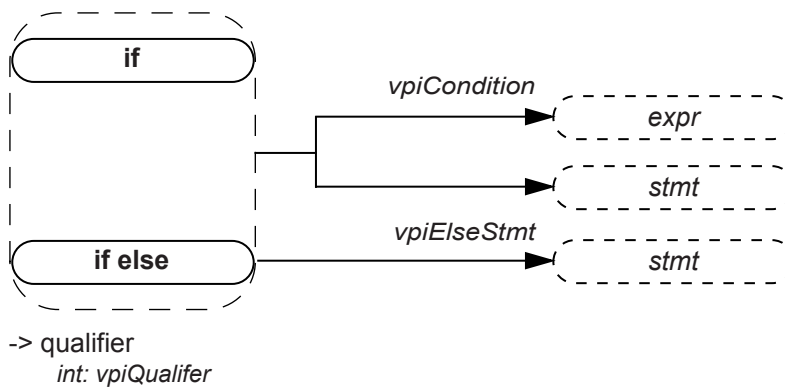

37.67 Case, pattern

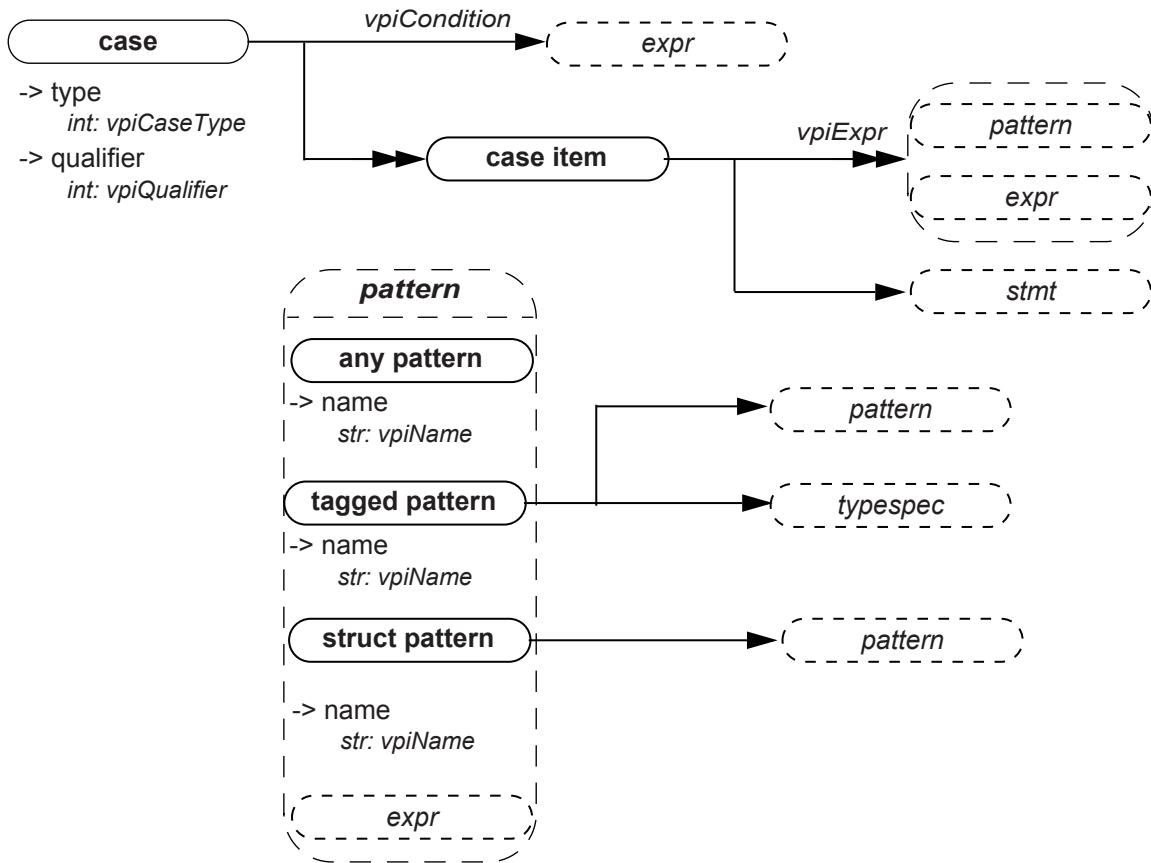

Details:

- 1) The case item shall group all case conditions that branch to the same statement.
- 2) **vpi_iterate()** shall return NULL for the default case item because there is no expression with the default case.

37.68 Expect

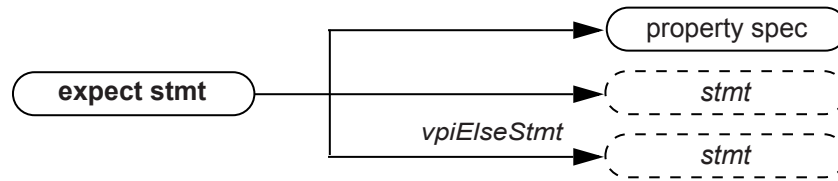

37.69 For

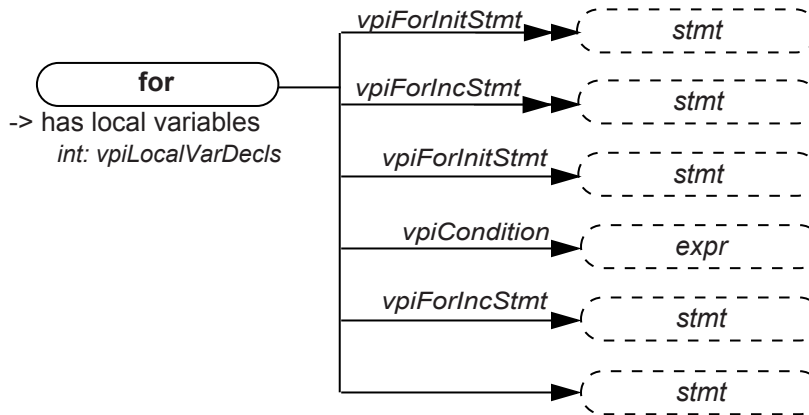

37.70 Do-while, foreach

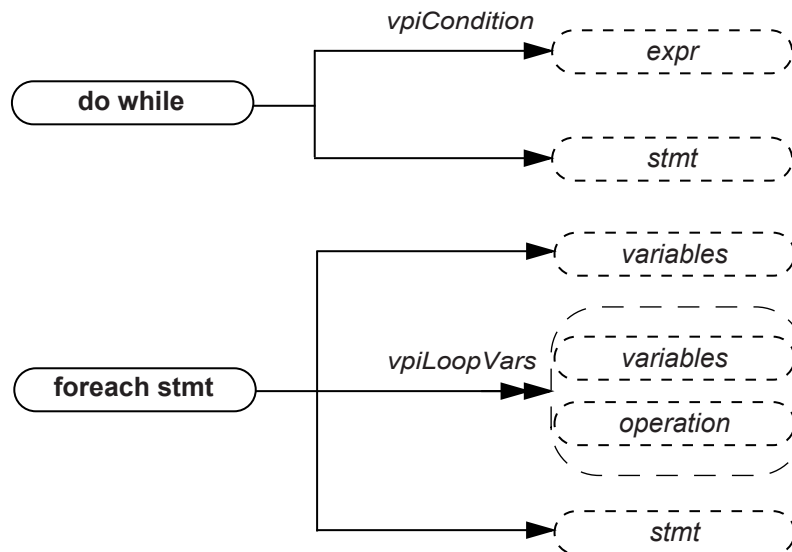

Details:

- 1) The variable obtained via the **vpiVariables** relation from a foreach stmt shall represent the packed array, unpacked array, or string var being indexed.
- 2) The **vpiLoopVars** iteration shall return the index variables of the foreach statement in left-to-right order. If an index variable is skipped, its place shall be represented as a **vpiOperation** for which the **vpiOpType** is **vpiNullOp**.

37.71 Alias statement



Example:

```
alias a=b=c=d;
```

results in 3 aliases:

```
alias a=d;  
alias b=d;  
alias c=d;
```

d is the Rhs for all.

37.72 Disables

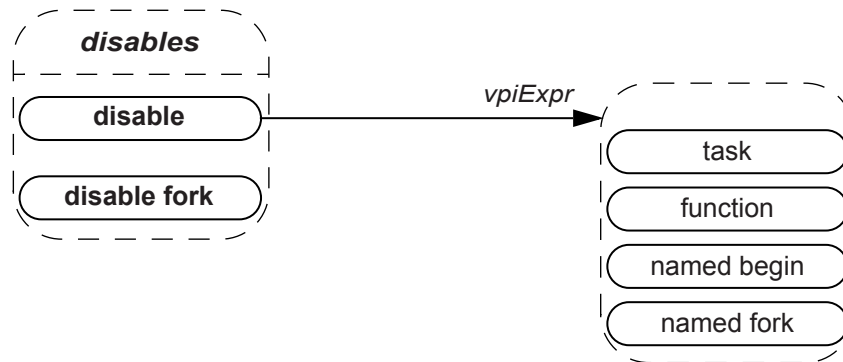

37.73 Return statement

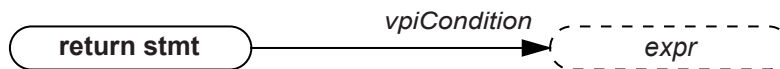

37.74 Assign statement, deassign, force, release

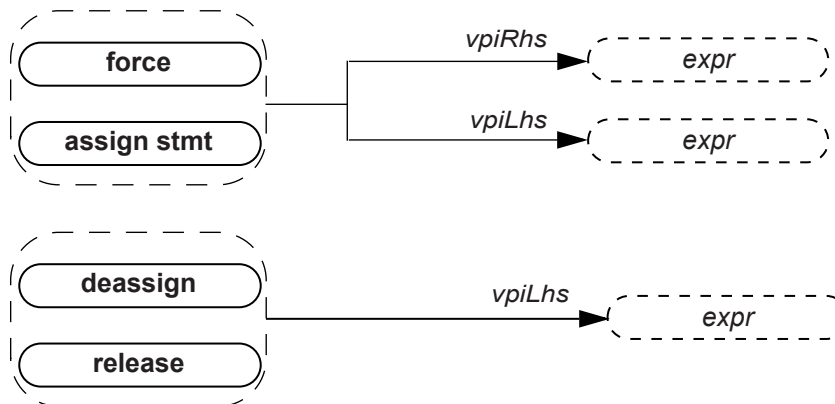

37.75 Callback

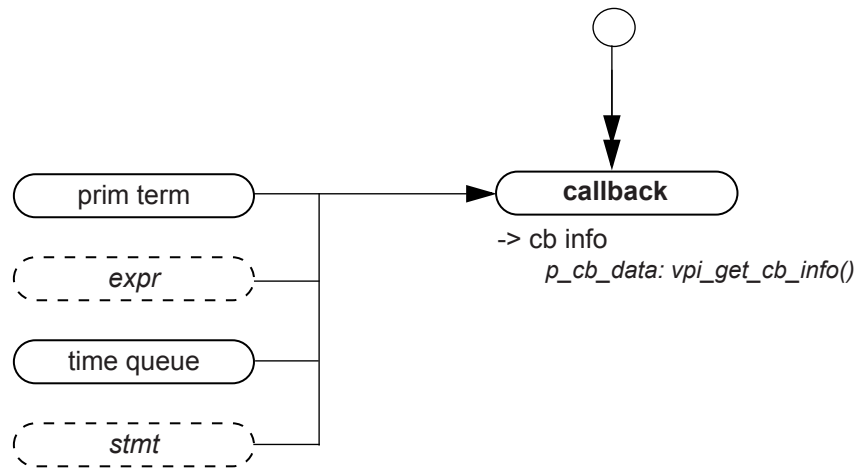

Details:

- 1) To get information about the callback object, the routine **vpi_get_cb_info()** can be used..
- 2) To get callback objects not related to the above objects, the second argument to **vpi_iterate()** shall be NULL.

37.76 Time queue

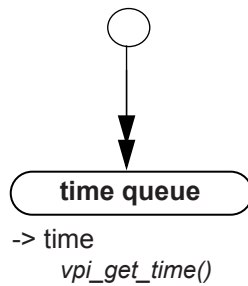

Details:

- 1) The time queue objects shall be returned in increasing order of simulation time.
- 2) **vpi_iterate()** shall return NULL if there is nothing left in the simulation time queue.
- 3) The current time queue shall only be returned as part of the iteration if there are events that precede read only sync.

37.77 Active time format

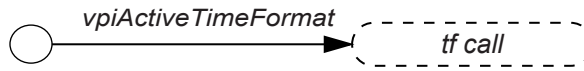

Details:

- 1) If `$timeformat()` has not been called, `vpi_handle(vpiActiveFormat, NULL)` shall return NULL.

37.78 Attribute

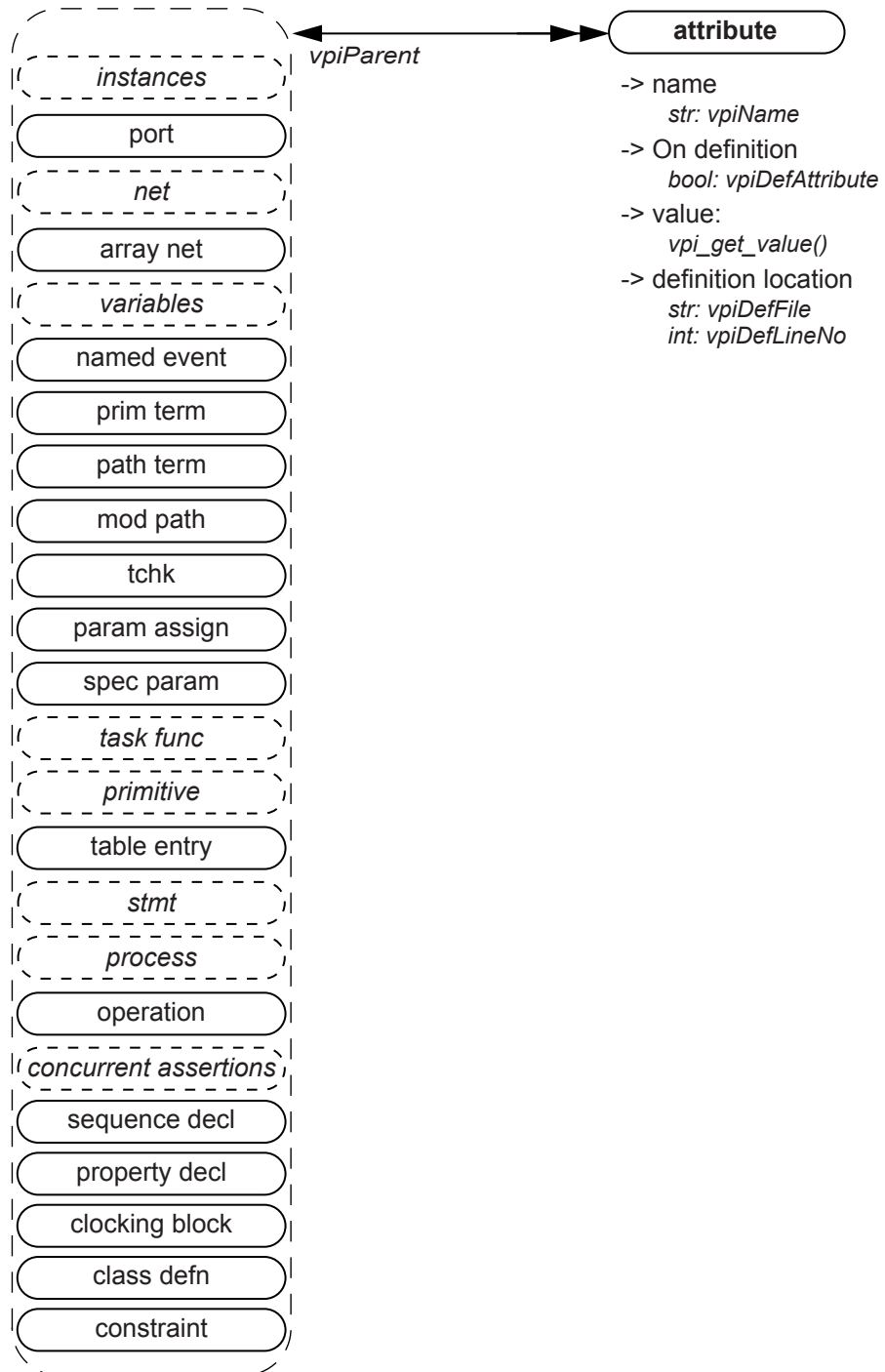

37.79 Iterator

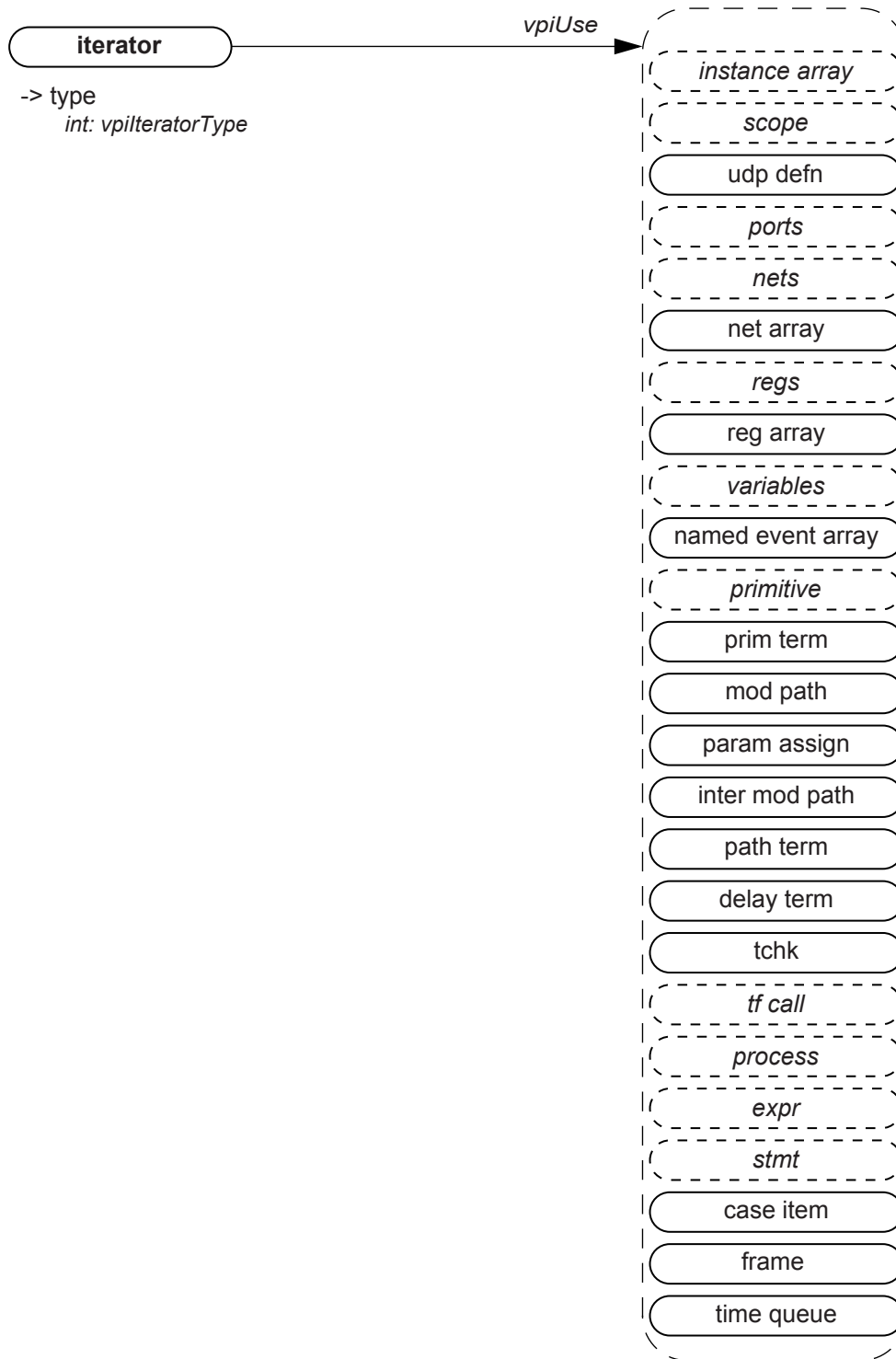

Details:

- 1) **vpi_handle(vpiUse, iterator_handle)** shall return the reference handle used to create the iterator.
- 2) It is possible to have a NULL reference handle, in which case **vpi_handle(vpiUse, iterator_handle)** shall return NULL.

37.80 Generates

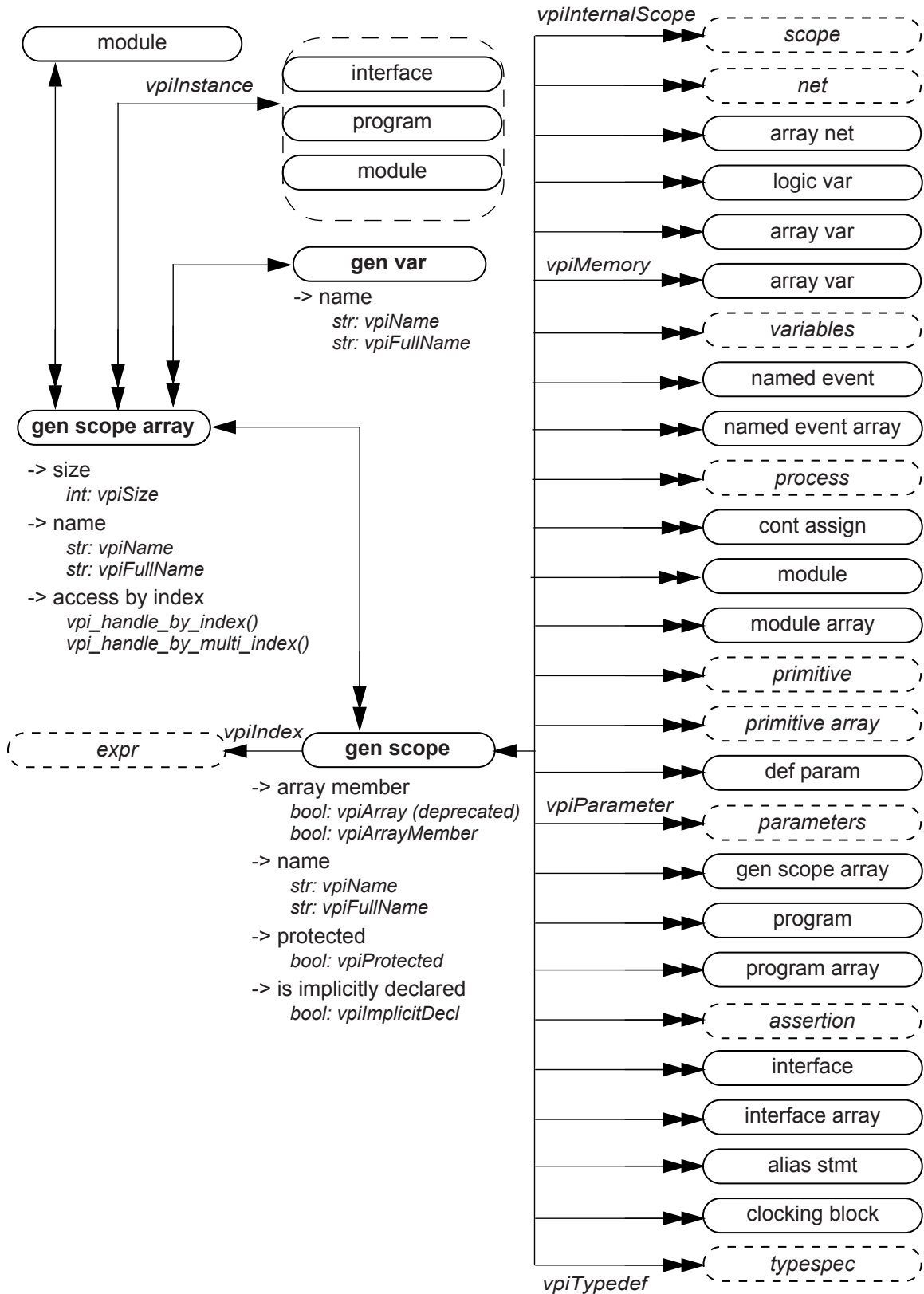

Details:

- 1) The size for a gen scope array shall be the number of elements in the array.
- 2) For an unnamed generate, an implicit scope shall be created. Its **vpImplicitDecl** property shall return TRUE.
- 3) References to gen vars within the gen scope shall be treated as local parameters.
- 4) Parameters within the gen scope must be local parameters.

38. VPI routine definitions

38.1 General

This clause describes the VPI routines and explains their function, syntax, and usage. The routines are listed in alphabetical order.

The following conventions are used in the definitions of the PLI routines described in this clause:

- **Synopsis:** A brief description of the PLI routine functionality, intended to be used as a quick reference when searching for PLI routines to perform specific tasks.
- **Syntax:** The exact name of the PLI routine and the order of the arguments passed to the routine.
- **Returns:** The definition of the value returned when the PLI routine is called, along with a brief description of what the value represents. The return definition contains the following fields:
 - **Type:** The data type of the C value that is returned. The data type is either a standard ANSI C type or a special type defined within the PLI.
 - **Description:** A brief description of what the value represents.
- **Arguments:** The definition of the arguments passed with a call to the PLI routine. The argument definition contains the following fields:
 - **Type:** The data type of the C values that are passed as arguments. The data type is either a standard ANSI C type or a special type defined within the PLI.
 - **Name:** The name of the argument used in the syntax definition.
 - **Description:** A brief description of what the value represents.

All arguments shall be considered mandatory unless specifically noted in the definition of the PLI routine.

- **Related routines:** A list of PLI routines that are typically used with, or provide similar functionality to, the PLI routine being defined. This list is provided as a convenience to facilitate finding information in this standard. It is not intended to be all-inclusive, and it does not imply that the related routines have to be used.

38.2 vpi_chk_error()

vpi_chk_error()			
Synopsis:	Retrieve information about VPI routine errors.		
Syntax:	vpi_chk_error(error_info_p)		
	Type	Description	
Returns:	PLI_INT32	The error severity level if the previous VPI routine call resulted in an error; 0 (false) if no error occurred.	
	Type	Name	Description
Arguments:	p_vpi_error_info	error_info_p	Pointer to a structure containing error information.
Related routines:			

The VPI routine **vpi_chk_error()** shall return an integer constant representing an error severity level if the previous call to a VPI routine resulted in an error. The error constants are shown in [Table 38-1](#). If the previous call to a VPI routine did not result in an error, then **vpi_chk_error()** shall return **0** (false). The error

status shall be reset by any VPI routine call except **vpi_chk_error()**. Calling **vpi_chk_error()** shall have no effect on the error status.

Table 38-1—Return error constants for vpi_chk_error()

Error constant	Severity level
vpiNotice	Lowest severity
vpiWarning	
vpiError	
vpiSystem	
vpiInternal	Highest severity

If an error occurred, the `s_vpi_error_info` structure shall contain information about the error. If the error information is not needed, a `NULL` can be passed to the routine. The `s_vpi_error_info` structure used by **vpi_chk_error()** is defined in `vpi_user.h` and is listed in [Figure 38-1](#).

```
typedef struct t_vpi_error_info
{
    PLI_INT32 state;          /* vpi[Compile,PLI,Run] */
    PLI_INT32 level;        /* vpi[Notice,Warning,Error,System,Internal] */
    PLI_BYTE8 *message;
    PLI_BYTE8 *product;
    PLI_BYTE8 *code;
    PLI_BYTE8 *file;
    PLI_INT32 line;
} s_vpi_error_info, *p_vpi_error_info;
```

Figure 38-1—s_vpi_error_info structure definition

38.3 vpi_compare_objects()

vpi_compare_objects()			
Synopsis:	Compare two handles to determine whether they reference the same object.		
Syntax:	<code>vpi_compare_objects(obj1, obj2)</code>		
	Type	Description	
Returns:	PLI_INT32	1 (true) if the two handles refer to the same object; 0 (false) otherwise.	
	Type	Name	Description
Arguments:	vpiHandle	obj1	Handle to an object.
	vpiHandle	obj2	Handle to an object.
Related routines:			

The VPI routine **vpi_compare_objects()** shall return 1 (TRUE) if the two handles refer to the same underlying simulation object at the time the function is called, provided that the simulation object exists.

Otherwise, 0 (FALSE) shall be returned. Object equivalence cannot be determined with a C '==' comparison.

The following examples illustrate the use of `vpi_compare_objects()`.

Example 1:

```

struct packed {
    int a;
    reg [0:7] b;
} ps;
...
initial begin
    ps[0] = ...;
    ps.b[7] = ...;
end

```

The expression `ps[0]` is another way of referring to bit 7 of `ps.b`. So if a handle `obj1` refers to `ps[0]` and a handle `obj2` refers to `ps.b[7]`, then `vpi_compare_objects(obj1, obj2)` shall return TRUE.

Example 2:

```

integer i [0:3];
int j;
...
initial begin
    j = 0;
    i[j] = ...;
    #(1)
    j = 1;
    i[j] = ...;
end

```

Let `obj1` be a handle to an occurrence of the expression `i[j]`, and let `obj2` be a handle to the object `i[0]` derived by iteration from the integer array `i`. Then

```
vpi_compare_objects(obj1, obj2)
```

shall return TRUE when `j` has the value 0 and FALSE when `j` has the value 1.

Example 3:

```

class MyClass;
    int a;
endclass
...
MyClass c, d;
...
initial begin
    c = NULL;
    d = NULL;
    #(1)
    c = new;
    c.a = 5;
    #(1)
    d = c;
    d.a = 6;
end

```



```
#(1)
c = new;
c.a = 7;
end
```

If `obj1` represents the expression `c.a`, while `obj2` represents `d.a`, then initially neither object exists, and `vpi_compare_objects(obj1, obj2)` shall return `FALSE`. After one time step, `c.a` exists, but `d.a` does not, and `vpi_compare_objects(obj1, obj2)` shall still return `FALSE`. After the second time step, `c.a` and `d.a` point to the same `int` data member of the same class object, and `vpi_compare_objects(obj1, obj2)` shall return `TRUE`. Finally, `c` gets a new class object assigned to it, but `d` does not, and `vpi_compare_objects(obj1, obj2)` shall once again return `FALSE`.

38.4 vpi_control()

vpi_control()			
Synopsis:	Pass information from the application code to the simulator.		
Syntax:	<code>vpi_control(operation, varargs)</code>		
	Type	Description	
Returns:	PLI_INT32	1 (true) if successful; 0 (false) on a failure.	
	Type	Name	Description
Arguments:	PLI_INT32	operation	Select type of operation.
		varargs	Variable number of operation-specific arguments.
Related routines:			

The VPI routine `vpi_control()` shall pass information from a user PLI application to a SystemVerilog software tool, such as a simulator. The following control constants are defined as part of the VPI standard:

- vpiStop** Causes the `$stop` built-in SystemVerilog system task to be executed upon return of the application routine. This operation shall be passed one additional integer argument, which is the same as the diagnostic message level argument passed to `$stop` (see [20.2](#)).
- vpiFinish** Causes the `$finish` built-in SystemVerilog system task to be executed upon return of the application routine. This operation shall be passed one additional integer argument, which is the same as the diagnostic message level argument passed to `$finish` (see [20.2](#)).
- vpiReset** Causes the `$reset` built-in SystemVerilog system task to be executed upon return of the application routine. This operation shall be passed three additional integer arguments: `stop_value`, `reset_value`, and `diagnostic_level`, which are the same values passed to the `$reset` system task (see [D.8](#)).
- vpiSetInteractiveScope** Causes a tool's interactive scope to be immediately changed to a new scope. This operation shall be passed one additional argument, which is a `vpiHandle` object within the `vpiScope` class.

38.5 vpi_flush()

vpi_flush()			
Synopsis:	Flushes the data from the simulator output channel and log file output buffers.		
Syntax:	vpi_flush()		
	Type	Description	
Returns:	PLI_INT32	0 if successful; nonzero if unsuccessful.	
	Type	Name	Description
Arguments:	None		
Related routines:	Use vpi_printf() to write a finite number of arguments to the simulator output channel and log file. Use vpi_vprintf() to write a variable number of arguments to the simulator output channel and log file. Use vpi_mcd_printf() to write one or more opened files.		

The routine **vpi_flush()** shall flush the output buffers for the simulator's output channel and current log file.

38.6 vpi_get()

vpi_get()			
Synopsis:	Get the value of an integer or Boolean property of an object.		
Syntax:	vpi_get(prop, obj)		
	Type	Description	
Returns:	PLI_INT32	Value of an integer or Boolean property.	
	Type	Name	Description
Arguments:	PLI_INT32	prop	An integer constant representing the property of an object for which to obtain a value.
	vpiHandle	obj	Handle to an object.
Related routines:	Use vpi_get_str() to get string properties. Use vpi_get64() to get 64 bit integer properties.		

The VPI routine **vpi_get()** shall return the value of integer and Boolean object properties. These properties shall be of type `PLI_INT32`. Boolean properties shall have a value of 1 for TRUE and 0 for FALSE. For integer object properties such as **vpiSize**, any integer shall be returned. For integer object properties that return a defined value, see [Annex K](#) and [Annex M](#) for the value that shall be returned. For object property **vpiTimeUnit** or **vpiTimePrecision**, if the object is `NULL`, then the simulation time unit shall be returned. Unless otherwise specified, calling **vpi_get()** for a protected object shall be an error. Should an error occur, **vpi_get()** shall return **vpiUndefined**.

38.7 vpi_get64()

vpi_get64()			
Synopsis:	Get the value of a 64 bit integer property of an object.		
Syntax:	vpi_get64(prop, obj)		
	Type	Description	
Returns:	PLI_INT64	Value of a 64 bit integer property.	
	Type	Name	Description
Arguments:	PLI_INT32	prop	An integer constant representing the property of an object for which to obtain a value.
	vpiHandle	obj	Handle to an object.
Related routines:	Use vpi_get_str() to get string properties. Use vpi_get() to get integer or Boolean properties.		

The VPI routine **vpi_get64()** shall return the value of 64 bit integer object properties. These properties shall be of type `PLI_INT64`. For 64 bit integer object properties that return a defined value, see [Annex K](#) and [Annex M](#) for the value that shall be returned. Unless otherwise specified, calling **vpi_get64()** for a protected object shall be an error. Should an error occur, **vpi_get64()** shall return **vpiUndefined**.

38.8 vpi_get_cb_info()

vpi_get_cb_info()			
Synopsis:	Retrieve information about a simulation-related callback.		
Syntax:	vpi_get_cb_info(obj, cb_data_p)		
	Type	Description	
Returns:	void		
	Type	Name	Description
Arguments:	vpiHandle	obj	Handle to a simulation-related callback.
	p_cb_data	cb_data_p	Pointer to a structure containing callback information.
Related routines:	Use vpi_get_systf_info() to retrieve information about a system task or system function callback.		

The VPI routine **vpi_get_cb_info()** shall return information about a simulation-related callback in an `s_cb_data` structure. The memory for this structure shall be allocated by the application.

The `s_cb_data` structure used by **vpi_get_cb_info()** is defined in `vpi_user.h` and is listed in [Figure 38-2](#).

```
typedef struct t_cb_data
{
    PLI_INT32    reason;           /* callback reason */
    PLI_INT32    (*cb_rtn)(struct t_cb_data *); /* call routine */
    vpiHandle    obj;            /* trigger object */
    p_vpi_time   time;           /* callback time */
    p_vpi_value  value;          /* trigger object value */
    PLI_INT32    index;          /* index of the memory word or var select
                                that changed */

    PLI_BYTE8    *user_data;
} s_cb_data, *p_cb_data;
```

Figure 38-2—s_cb_data structure definition

38.9 vpi_get_data()

vpi_get_data()			
Synopsis:	Get data from an implementation’s save/restart location.		
Syntax:	vpi_get_data(id, dataLoc, numOfBytes)		
	Type	Description	
Returns:	PLI_INT32	The number of bytes retrieved.	
	Type	Name	Description
Arguments:	PLI_INT32	id	A save/restart ID returned from vpi_get(vpiSaveRestartID, NULL) .
	PLI_BYTE8 *	dataLoc	Address of application-allocated storage.
	PLI_INT32	numOfBytes	Number of bytes to be retrieved from save/restart location.
Related routines:	Use vpi_put_data() to write saved data.		

The routine shall place *numOfBytes* of data into the memory location pointed to by *dataLoc* from a simulation’s save/restart location. This memory location has to be properly allocated by the application. The first call for a given *id* will retrieve the data starting at what was placed into the save/restart location with the first call to **vpi_put_data()** for a given *id*. The return value shall be the number of bytes retrieved. On a failure, the return value shall be 0. Each subsequent call shall start retrieving data where the last call left off. It shall be a warning for an application to retrieve more data than were placed into the simulation save/restart location for a given *id*. In this case, the *dataLoc* shall be filled with the data that are left for the given *id*, and the remaining bytes shall be filled with “\0”. The return value shall be the actual number of bytes retrieved. It shall be acceptable for an application to retrieve less data than were stored for a given *id* with **vpi_put_data()**. This routine can only be called from an application routine that has been called for reason **cbStartOfRestart** or **cbEndOfRestart**. The recommended way to get the “id” for **vpi_get_data()** is to pass it as the value for *user_data* when registering for **cbStartOfRestart** or **cbEndOfRestart** from the **cbStartOfSave** or **cbEndOfSave** application routine. An application can get the path to the simulation’s save/restart location by calling **vpi_get_str(vpiSaveRestartLocation, NULL)** from an application routine that has been called for reason **cbStartOfRestart** or **cbEndOfRestart**.

For an example of **vpi_get_data()**, see [38.31](#).

38.10 vpi_get_delays()

vpi_get_delays()			
Synopsis:	Retrieve the delays or pulse limits of an object.		
Syntax:	vpi_get_delays(obj, delay_p)		
Returns:	Type	Description	
	void		
Arguments:	Type	Name	Description
	vpiHandle	obj	Handle to an object.
	p_vpi_delay	delay_p	Pointer to a structure containing delay information.
Related routines:	Use vpi_put_delays() to set the delays or timing limits of an object.		

The VPI routine **vpi_get_delays()** shall retrieve the delays or pulse limits of an object and place them in an `s_vpi_delay` structure that has been allocated by the application. The format of the delay information shall be controlled by the *time_type* flag in the `s_vpi_delay` structure. This routine shall ignore the value of the *type* flag in the `s_vpi_time` structure.

The `s_vpi_delay` and `s_vpi_time` structures used by both **vpi_get_delays()** and **vpi_put_delays()** are defined in `vpi_user.h` and are listed in [Figure 38-3](#) and [Figure 38-4](#).

```
typedef struct t_vpi_delay
{
    struct t_vpi_time *da;          /* pointer to application-allocated
                                   array of delay values */
    PLI_INT32 no_of_delays;        /* number of delays */
    PLI_INT32 time_type;          /* [vpiScaledRealTime, vpiSimTime,
                                   or vpiSuppressTime] */
    PLI_INT32 mtm_flag;           /* true for mtm values */
    PLI_INT32 append_flag;        /* true for append */
    PLI_INT32 pulserere_flag;      /* true for pulserere values */
} s_vpi_delay, *p_vpi_delay;
```

Figure 38-3—s_vpi_delay structure definition

```
typedef struct t_vpi_time
{
    PLI_INT32 type;               /* [vpiScaledRealTime, vpiSimTime,
                                   vpiSuppressTime] */
    PLI_UINT32 high, low;         /* for vpiSimTime */
    double real;                 /* for vpiScaledRealTime */
} s_vpi_time, *p_vpi_time;
```

Figure 38-4—s_vpi_time structure definition

The *da* field of the `s_vpi_delay` structure shall be an application-allocated array of `s_vpi_time` structures. This array shall store delay values returned by **vpi_get_delays()**. The number of elements in this array shall be determined by the following:

- The number of delays to be retrieved
- The **mtm_flag** setting
- The **pulsere_flag** setting

The number of delays to be retrieved shall be set in the *no_of_delays* field of the *s_vpi_delay* structure. Legal values for the number of delays shall be determined by the type of object, as follows:

- For primitive objects, the *no_of_delays* value shall be 2 or 3.
- For path delay objects, the *no_of_delays* value shall be 1, 2, 3, 6, or 12.
- For timing check objects, the *no_of_delays* value shall match the number of limits existing in the timing check.
- For intermodule path objects, the *no_of_delays* value shall be 2 or 3.

The application-allocated *s_vpi_delay* array shall contain delays in the same order in which they occur in the SystemVerilog description. The number of elements for each delay shall be determined by the flags **mtm_flag** and **pulsere_flag**, as shown in [Table 38-2](#).

Table 38-2—Size of the *s_vpi_delay->da* array

Flag values	Number of <i>s_vpi_time</i> array elements required for <i>s_vpi_delay->da</i>	Order in which delay elements shall be filled
mtm_flag = FALSE pulsere_flag = FALSE	<i>no_of_delays</i>	1st delay: <i>da</i> [0] -> 1st delay 2nd delay: <i>da</i> [1] -> 2nd delay ...
mtm_flag = TRUE pulsere_flag = FALSE	3 * <i>no_of_delays</i>	1st delay: <i>da</i> [0] -> min delay <i>da</i> [1] -> typ delay <i>da</i> [2] -> max delay 2nd delay: ...
mtm_flag = FALSE pulsere_flag = TRUE	3 * <i>no_of_delays</i>	1st delay: <i>da</i> [0] -> delay <i>da</i> [1] -> reject limit <i>da</i> [2] -> error limit 2nd delay element: ...
mtm_flag = TRUE pulsere_flag = TRUE	9 * <i>no_of_delays</i>	1st delay: <i>da</i> [0] -> min delay <i>da</i> [1] -> typ delay <i>da</i> [2] -> max delay <i>da</i> [3] -> min reject <i>da</i> [4] -> typ reject <i>da</i> [5] -> max reject <i>da</i> [6] -> min error <i>da</i> [7] -> typ error <i>da</i> [8] -> max error 2nd delay: ...

The delay structure has to be allocated before passing a pointer to **vpi_get_delays()**. In the following example, a static structure, **prim_da**, is allocated for use by each call to the **vpi_get_delays()** function:

```
display_prim_delays(prim)
vpiHandle prim;

{
    static s_vpi_time prim_da[3];
    static s_vpi_delay delay_s = {NULL, 3, vpiScaledRealTime};
    static p_vpi_delay delay_p = &delay_s;

    delay_s.da = prim_da;
    vpi_get_delays(prim, delay_p);
    vpi_printf("Delays for primitive %s: %6.2f %6.2f %6.2f\n",
```

```

    vpi_get_str(vpiFullName, prim)
    delay_p->da[0].real, delay_p->da[1].real, delay_p->da[2].real);
}

```

38.11 vpi_get_str()

vpi_get_str()			
Synopsis:	Get the value of a string property of an object.		
Syntax:	vpi_get_str(prop, obj)		
	Type	Description	
Returns:	PLI_BYTE8 *	Pointer to a character string containing the property value.	
	Type	Name	Description
Arguments:	PLI_INT32	prop	An integer constant representing the property of an object for which to obtain a value.
	vpiHandle	obj	Handle to an object.
Related routines:	Use vpi_get() to get integer and Boolean properties. Use vpi_get64() to get 64 bit integer properties.		

The VPI routine **vpi_get_str()** shall return string property values. The string shall be placed in a temporary buffer that shall be used by every call to this routine. If the string is to be used after a subsequent call, the string should be copied to another location. A different string buffer shall be used for string values returned through the `s_vpi_value` structure. Unless otherwise specified, calling **vpi_get_str()** for a protected object shall be an error.

The following example illustrates the usage of **vpi_get_str()**:

```

vpiHandle mod = vpi_handle_by_name("top.mod1", NULL);
vpi_printf ("Module top.mod1 is an instance of %s\n",
vpi_get_str(vpiDefName, mod));

```

38.12 vpi_get_systf_info()

vpi_get_systf_info()			
Synopsis:	Retrieve information about a user-defined system task or system function callback.		
Syntax:	vpi_get_systf_info(obj, systf_data_p)		
	Type	Description	
Returns:	void		
	Type	Name	Description
Arguments:	vpiHandle	obj	Handle to a system task or system function callback.
	p_vpi_systf_data	systf_data_p	Pointer to a structure containing callback information.
Related routines:	Use vpi_get_cb_info() to retrieve information about a simulation-related callback.		

The VPI routine **vpi_get_systf_info()** shall return information about a user-defined system task or system function callback in an `s_vpi_systf_data` structure. The memory for this structure shall be allocated by the application.

The `s_vpi_systf_data` structure used by **vpi_get_systf_info()** is defined in `vpi_user.h` and is listed in [Figure 38-5](#).

```
typedef struct t_vpi_systf_data
{
    PLI_INT32 type;          /* vpiSysTask, vpiSysFunc */
    PLI_INT32 sysfunc_type; /* vpiSysTask, vpi[Int,Real,Time,Sized,
                               SizedSigned]Func */
    PLI_BYTE8 *tfname;     /* first character must be '$' */
    PLI_INT32 (*calltf)(PLI_BYTE8 *);
    PLI_INT32 (*compiletf)(PLI_BYTE8 *);
    PLI_INT32 (*sizetf)(PLI_BYTE8 *); /* for sized function
                                         callbacks only */
    PLI_BYTE8 *user_data;
} s_vpi_systf_data, *p_vpi_systf_data;
```

Figure 38-5—s_vpi_systf_data structure definition

38.13 vpi_get_time()

vpi_get_time()			
Synopsis:	Retrieve the current simulation time.		
Syntax:	vpi_get_time(obj, time_p)		
	Type	Description	
Returns:	void		
	Type	Name	Description
Arguments:	vpiHandle	obj	Handle to an object.
	p_vpi_time	time_p	Pointer to a structure containing time information.
Related routines:			

The VPI routine **vpi_get_time()** shall retrieve the current simulation time, using the timescale of the object. If *obj* is `NULL`, the simulation time is retrieved using the simulation time unit. If *obj* is a time queue object, the scheduled time of the future event is retrieved using the simulation time unit. The *time_p->type* field shall be set to indicate if scaled real or simulation time is desired. The memory for the *time_p* structure shall be allocated by the application.

The `s_vpi_time` structure used by **vpi_get_time()** is defined in `vpi_user.h` and is listed in [Figure 38-6](#) [this is the same time structure as used by **vpi_put_value()**].

```
typedef struct t_vpi_time
{
  PLI_INT32  type;           /* [vpiScaledRealTime, vpiSimTime,
                             vpiSuppressTime] */
  PLI_UINT32 high, low;     /* for vpiSimTime */
  double     real;         /* for vpiScaledRealTime */
} s_vpi_time, *p_vpi_time;
```

Figure 38-6—s_vpi_time structure definition

38.14 vpi_get_userdata()

vpi_get_userdata()			
Synopsis:	Get user-data value from an implementation's system task or system function instance storage location.		
Syntax:	vpi_get_userdata(obj)		
	Type	Description	
Returns:	void *	User-data value associated with a system task instance or system function instance.	
	Type	Name	Description
Arguments:	vpiHandle	obj	Handle to a system task instance or system function instance.
Related routines:	Use vpi_put_userdata() to write data into the user-data storage area.		

This routine shall return the value of the user data associated with a previous call to **vpi_put_userdata()** for a user-defined system task or system function call handle. If no user data had been previously associated with the object or if the routine fails, the return value shall be **NULL**.

After a restart or a reset, subsequent calls to **vpi_get_userdata()** shall return **NULL**. It is the application's responsibility to save the data during a save using **vpi_put_data()** and to then retrieve them using **vpi_get_data()**. The user-data field can be set up again during or after callbacks of type **cbEndOfRestart** or **cbEndOfReset**.

38.15 vpi_get_value()

vpi_get_value()			
Synopsis:	Retrieve the simulation value of an object.		
Syntax:	vpi_get_value(obj, value_p)		
	Type	Description	
Returns:	void		
	Type	Name	Description
Arguments:	vpiHandle	obj	Handle to an expression.
	p_vpi_value	value_p	Pointer to a structure containing value information.
Related routines:	Use vpi_put_value() to set the value of an object.		

The VPI routine **vpi_get_value()** shall retrieve the simulation value of VPI objects. The value shall be placed in an **s_vpi_value** structure, which has been allocated by the application. The object shall be fully evaluated as if simulated in the context in which it occurs in the SystemVerilog source, including all expressions with side effects that occur as index expressions or as arguments to function calls embedded in the object expression.

For example, applying `vpi_get_value()` to the expression “`i++`” shall increment the value of `i` but shall return the unincremented value. Similarly, retrieving the simulation value of “`x[my_func(a)]`” shall evaluate `my_func(a)` in order to determine the value of the index expression.

The format of the value shall be set by the *format* field of the structure.

When the *format* field is `vpiObjTypeVal`, the routine shall fill in the value and change the *format* field based on the object type, as follows:

- For an integer, `vpiIntVal`
- For a real, `vpiRealVal`
- For a scalar, either `vpiScalar` or `vpiStrength`
- For a time variable, `vpiTimeVal` with `vpiSimTime`
- For a vector, `vpiVectorVal`

The buffer this routine uses for string values shall be different from the buffer that `vpi_get_str()` shall use. The string buffer used by `vpi_get_value()` is overwritten with each call. If the value is needed, it should be saved by the application.

The `s_vpi_value`, `s_vpi_vecval`, and `s_vpi_strengthval` structures used by `vpi_get_value()` are defined in `vpi_user.h` and are listed in [Figure 38-7](#), [Figure 38-8](#), and [Figure 38-9](#).

```
typedef struct t_vpi_value
{
    PLI_INT32 format; /* vpi[[Bin,Oct,Dec,Hex]Str,Scalar,Int,Real,String,
                    Vector,Strength,Suppress,Time,ObjType]Val */
    union
    {
        PLI_BYTE8 *str; /* string value */
        PLI_INT32 scalar; /* vpi[0,1,X,Z] */
        PLI_INT32 integer; /* integer value */
        double real; /* real value */
        struct t_vpi_time *time; /* time value */
        struct t_vpi_vecval *vector; /* vector value */
        struct t_vpi_strengthval *strength; /* strength value */
        PLI_BYTE8 *misc; /* ...other */
    } value;
} s_vpi_value, *p_vpi_value;
```

Figure 38-7—s_vpi_value structure definition

```
typedef struct t_vpi_vecval
{
    /* following fields are repeated enough times to contain vector */
    PLI_UINT32 aval, bval; /* bit encoding: ab: 00=0, 10=1, 11=X, 01=Z */
} s_vpi_vecval, *p_vpi_vecval;
```

Figure 38-8—s_vpi_vecval structure definition

```
typedef struct t_vpi_strengthval
{
    PLI_INT32 logic; /* vpi[0,1,X,Z] */
    PLI_INT32 s0, s1; /* refer to strength coding in Annex K */
} s_vpi_strengthval, *p_vpi_strengthval;
```

Figure 38-9—s_vpi_strengthval structure definition

For vectors, the *p_vpi_vecval* field shall point to an array of *s_vpi_vecval* structures. The size of this array shall be determined by the size of the vector, where $array_size = ((vector_size-1)/32 + 1)$. The lsb of the vector shall be represented by the lsb of the 0-indexed element of *s_vpi_vecval* array. The 33rd bit of the vector shall be represented by the lsb of the 1-indexed element of the array, and so on. The memory for the union members *str*, *time*, *vector*, *strength*, and *misc* of the value union in the *s_vpi_value* structure shall be provided by the routine **vpi_get_value()**. This memory shall only be valid until the next call to **vpi_get_value()**. The application shall provide the memory for these members when calling **vpi_put_value()**. When a value change callback occurs for a value type of **vpiVectorVal**, the system shall create the associated memory (an array of *s_vpi_vecval* structures) and free the memory upon the return of the callback.

Table 38-3—Return value field of the s_vpi_value structure union

Format	Union member	Return description
vpiBinStrVal	str	String of binary character(s) [1 , 0 , x , z]
vpiOctStrVal	str	String of octal character(s) [0-7 , x , X , z , Z] x when all the bits are x X when some of the bits are x z when all the bits are z Z when some of the bits are z
vpiDecStrVal	str	String of decimal character(s) [0-9]
vpiHexStrVal	str	String of hex character(s) [0-f , x , X , z , Z] x when all the bits are x X when some of the bits are x z when all the bits are z Z when some of the bits are z
vpiScalarVal	scalar	vpi1 , vpi0 , vpiX , vpiZ , vpiH , vpiL
vpiIntVal	integer	Integer value of the handle. Any bits x or z in the value of the object are mapped to a 0
vpiRealVal	real	Value of the handle as a double
vpiStringVal	str	A string where each 8-bit group of the value of the object is assumed to represent an ASCII character
vpiTimeVal	time	Integer value of the handle using two integers
vpiVectorVal	vector	<i>aval/bval</i> representation of the value of the object
vpiStrengthVal	strength	Value plus strength information
vpiObjTypeVal	—	Return a value in the closest format of the object

If the format field in the *s_vpi_value* structure is set to **vpiStrengthVal**, the *value.strength* pointer shall point to an array of *s_vpi_strengthval* structures. This array shall have at least as many elements as there are bits in the vector. If the object is a reg or variable, the strength will always be returned as strong.

If the logic value retrieved by **vpi_get_value()** needs to be preserved for later use, the application shall allocate storage and copy the value. The following example can be used to copy a value that was retrieved into an *s_vpi_value* structure into another structure allocated by the application:

```

/*
 * Copy s_vpi_value structure - must first allocate pointed to fields.
 * nvalp must be previously allocated.
 * Need to first determine size for vector value.

```

```
*/
void copy_vpi_value(s_vpi_value *nvalp, s_vpi_value *ovalp,
                   PLI_INT32 blen, PLI_INT32 nd_alloc)
{
    int i;
    PLI_INT32 numvals;
    nvalp->format = ovalp->format;
    switch (nvalp->format) {
        /* all string values */
        case vpiBinStrVal: case vpiOctStrVal: case vpiDecStrVal:
        case vpiHexStrVal: case vpiStringVal:
            if (nd_alloc) nvalp->value.str = malloc(strlen(ovalp->value.str)+1);
                strcpy(nvalp->value.str, ovalp->value.str);
            break;
        case vpiScalarVal:
            nvalp->value.scalar = ovalp->value.scalar;
            break;
        case vpiIntVal:
            nvalp->value.integer = ovalp->value.integer;
            break;
        case vpiRealVal:
            nvalp->value.real = ovalp->value.real;
            break;
        case vpiVectorVal:
            numvals = (blen + 31) >> 5;
            if (nd_alloc)
            {
                nvalp->value.vector = (p_vpi_vecval)
                    malloc(numvals*sizeof(s_vpi_vecval));
            }
            /* t_vpi_vecval is really array of the 2 integer a/b sections */
            /* memcpy or bcopy better here */
            for (i = 0; i < numvals; i++)
                nvalp->value.vector[i] = ovalp->value.vector[i];
            break;
        case vpiStrengthVal:
            if (nd_alloc)
            {
                nvalp->value.strength = (p_vpi_strengthval)
                    malloc(sizeof(s_vpi_strengthval));
            }
            /* assumes C compiler supports struct assign */
            *(nvalp->value.strength) = *(ovalp->value.strength);
            break;
        case vpiTimeVal:
            nvalp->value.time = (p_vpi_time) malloc(sizeof(s_vpi_time));
            /* assumes C compiler supports struct assign */
            *(nvalp->value.time) = *(ovalp->value.time);
            break;
        /* not sure what to do here? */
        case vpiObjTypeVal: case vpiSuppressVal:
            vpi_printf(
                "***ERR: cannot copy vpiObjTypeVal or vpiSuppressVal formats",
                " - not for filled records.\n");
            break;
    }
}
}
```

To get the ASCII values of UDP table entries (see [Table 29-1](#) in [29.3.6](#)), the *p_vpi_vecval* field shall point to an array of *s_vpi_vecval* structures. The size of this array shall be determined by the size of the table entry (number of symbols per table entry), where $array_size = ((table_entry_size-1)/4 + 1)$. Each symbol shall require two bytes; the ordering of the symbols within *s_vpi_vecval* shall be the most significant byte of *abit* first, then the least significant byte of *abit*, then the most significant byte of *bbit*, and then the least significant byte of *bbit*. Each symbol can be either one or two characters; when it is a single character, the second byte of the pair shall be an ASCII “\0”.

Real valued objects shall be converted to an integer using the rounding defined in [6.12.2](#) before being returned in a format other than **vpiRealVal** and **vpiStringVal**. If the format specified is **vpiStringVal**, then the value shall be returned as a string representation of a floating point number. The format of this string shall be in decimal notation with at most 16 digits of precision.

If a constant object’s **vpiConstType** is **vpiStringVal**, the value shall be retrieved using a format of either **vpiStringVal** or **vpiVectorVal**.

The *misc* field in the *s_vpi_value* structure shall provide for alternative value types, which can be implementation-specific. If this field is utilized, one or more corresponding format types shall also be provided.

In the following example, the binary value of each net that is contained in a particular module and whose name begins with a particular string is displayed. [This function makes use of the `strcmp()` facility normally declared in a `string.h` C library.]

```
void display_certain_net_values(mod, target)
vpiHandle mod;
PLI_BYTE8 *target;
{
    static s_vpi_value value_s = {vpiBinStrVal};
    static p_vpi_value value_p = &value_s;
    vpiHandle net, itr;

    itr = vpi_iterate(vpiNet, mod);
    while (net = vpi_scan(itr))
    {
        PLI_BYTE8 *net_name = vpi_get_str(vpiName, net);
        if (strcmp(target, net_name) == 0)
        {
            vpi_get_value(net, value_p);
            vpi_printf("Value of net %s: %s\n",
                vpi_get_str(vpiFullName, net), value_p->value.str);
        }
    }
}
```

The following example illustrates the use of `vpi_get_value()` to access UDP table entries. Two sample outputs from this example are provided after the example.

```
/*
 * hUDP must be a handle to a UDP definition
 */
static void dumpUDPTableEntries(vpiHandle hUDP)
{
    vpiHandle hEntry, hEntryIter;
    s_vpi_value value;
    PLI_INT32 numb;
```

```

    PLI_INT32 udpType;
    PLI_INT32 item;
    PLI_INT32 entryVal;
    PLI_INT32 *abItem;
    PLI_INT32 cnt, cnt2;
    numb = vpi_get(vpiSize, hUDP);
    udpType = vpi_get(vpiPrimType, hUDP);
    if (udpType == vpiSeqPrim)
        numb++; /* There is one more table entry for state */
    numb++; /* There is a table entry for the output */
    hEntryIter = vpi_iterate(vpiTableEntry, hUDP);
    if (!hEntryIter)
        return;
    value.format = vpiVectorVal;
    while(hEntry = vpi_scan(hEntryIter))
    {
        vpi_printf("\n");
        /* Show the entry as a string */
        value.format = vpiStringVal;
        vpi_get_value(hEntry, &value);
        vpi_printf("%s\n", value.value.str);
        /* Decode the vector value format */
        value.format = vpiVectorVal;
        vpi_get_value(hEntry, &value);
        abItem = (PLI_INT32 *)value.value.vector;
        for(cnt=((numb-1)/2+1);cnt>0;cnt--)
        {
            entryVal = *abItem;
            abItem++;
            /* Rip out 4 characters */
            for (cnt2=0;cnt2<4;cnt2++)
            {
                item = entryVal&0xff;
                if (item)
                    vpi_printf("%c", item);
                else
                    vpi_printf("_");
                entryVal = entryVal>>8;
            }
        }
        vpi_printf("\n");
    }
}

```

For a UDP table of

```

1      0      :?:1;
0      (01)   :?:-;
(10)  0       :0:1;

```

the output from the preceding example would be

```

10:1
_0_1__1
01:0
_1_0__0
00:1
_0_0__1

```

For a UDP table entry of

```
1      0      :?:1;
0      (01)   :?:-;
(10)  0      :0:1;
```

the output from the preceding example would be

```
10:?:1
_0_1_1_?
0(01):?:-
10_0_ _?
(10)0:0:1
_001_1_0
```

38.16 vpi_get_value_array()

vpi_get_value_array()			
Synopsis:	Retrieve simulation values for contiguous elements of a static unpacked array object.		
Syntax:	vpi_get_value_array(obj, arrayvalue_p, index_p, num)		
	Type	Description	
Returns:	void		
	Type	Name	Description
Arguments:	vpiHandle	obj	Handle to an unpacked array object.
	p_vpi_arrayvalue	arrayvalue_p	Pointer to a structure containing array value information.
	PLI_INT32 *	index_p	Pointer to an array of index values corresponding to the start of the section of the object to be retrieved.
	PLI_UINT32	num	Number of array elements to be retrieved.
Related routines:	Use vpi_put_value_array() to set values of contiguous elements of a static unpacked array object		

The VPI routine **vpi_get_value_array()** shall retrieve simulation values of contiguous elements in static unpacked variable or net arrays (array objects for which the **vpiArrayType** property is **vpiStaticArray**). Such arrays must also have static lifetimes and not contain dynamic arrays or dynamic elements (e.g., string vars). For purposes here, the term element corresponds to any indexable member of such an array with all unpacked indices fully specified. The datatype of each element so defined corresponds to the datatype of the array with all unpacked ranges removed. The elements of arrays are not allowed to be of an unpacked type themselves (e.g., unpacked structs).

The values for the array section shall be placed in an `s_vpi_arrayvalue` structure defined in `vpi_user.h`, as follows:

```
typedef struct t_vpi_arrayvalue
{
    PLI_UINT32 format;
    PLI_UINT32 flags;
    union
```



```

    {
        PLI_INT32 *integers;
        PLI_INT16 *shortints;
        PLI_INT64 *longints;
        PLI_BYTE8 *rawvals;
        struct t_vpi_vecval *vectors;
        struct t_vpi_time *times;
        double    *reals;
        float     *shortreals;
    } value;
} s_vpi_arrayvalue, *p_vpi_arrayvalue;

```

The `s_vpi_arrayvalue` structure shown above shall be allocated by the application. However, the application has the flexibility of allocating the actual storage where the array element values are placed (see below). The layout of the values retrieved shall be set by the format field in the structure. In addition to the format types `vpiIntVal`, `vpiTimeVal`, `vpiVectorVal`, and `vpiRealVal` available with the `vpi_get_value()` function ([Table 38-3](#) in [38.15](#)), the following format types are available:

vpiRawFourStateVal Values for each element retrieved will be stored in `aval/bval` format (similar to 4-state vectors) using the `*rawvals` field of the union above, interleaved according to the following structure:

```

    struct
    {
        PLI_BYTE8 avalbits[ngroups];
        PLI_BYTE8 bvalbits[ngroups];
    }

```

Each array element occupies `ngroups*2` bytes stored consecutively as A/B byte groups as shown above. For the first indexed array element, the `avalbits` begins at `rawvals[0]`, and the `bvalbits` at `rawvals[ngroups]`, respectively. The second array element's `avalbits` begin at `rawvals[ngroups*2]`, and its `bvalbits` at `rawvals[ngroups*3]`, etc. `ngroups` is computed given the array element size in bits (= `elemBits`) as follows:

```
int ngroups = (elemBits + 7) / 8;
```

The total storage required to hold “num” array elements shall be `ngroups * num * 2`.

vpiRawTwoStateVal Values for each element retrieved shall be stored similarly to **vpiRawFourStateVal** above (also using the `*rawvals` struct member), except that the `bvalbits` byte group shall be omitted. `ngroups` shall be computed similarly also, but the total storage required shall instead be `ngroups * num`.

vpiShortIntVal Values retrieved will be stored as an array of “num” short(s), using the `*shortints` field in the union in this case. This format is appropriate only for arrays of **vpiShortIntVar** or **vpiByteVar** elements.

vpiLongIntVal Values retrieved will be stored as an array of “num” long(s), using the `*longints` field in the union in this case. This format is appropriate for arrays of **vpiLongIntVar**, **vpiShortIntVar** or **vpiByteVar** elements.

vpiShortRealVal Values retrieved will be stored as an array of “num” floats, using the `*shortrealvals` field in the union in this case. This format is appropriate only for arrays of **vpiShortRealVar** elements.

The format types `vpiIntVal`, `vpiTimeVal`, `vpiVectorVal`, and `vpiRealVal` that are also available with `vpi_get_value()` function correspond to similar union member names in `s_vpi_arrayvalue` (converted to pointer values and ending in “s” to indicate they are arrays). For example, selecting the `vpiIntVal` format

shall cause an array of 32-bit integers to be returned (which should be accessed using the **integers* field), each representing an indexed element of the array object. The **vpiVectorVal** format shall cause an array of consecutive A/B word groups formatted according to the *t_vpi_vecval* structure (Figure 38-8 in 38.15) to be retrieved. The **vectors* field should be used to access them. Given the array element size in bits ($= \text{elemBits}$), the number of words of storage required will be:

$$((\text{elemBits} + 31) / 32) * 2 * \text{num}$$

All other formats not mentioned here are unsupported, and shall result in an error if requested. Also, formats requested that are inconsistent with the datatype of the array elements (except where explicitly allowed) shall be considered an error.

The **vpiRawFourStateVal** and **vpiVectorVal** formats are appropriate for all 4-state array types (all net arrays, or variable arrays of **vpiLogicVar**, **vpiIntegerVar**, **vpiTimeVar**, or 4-state packed **vpiStructVar** or **vpiUnionVar** elements). The **vpiRawTwoStateVal** format is appropriate for all 2-state array types (variable arrays of **vpiBitVar**, **vpiByteVar**, **vpiShortInt**, **vpiInt**, **vpiLongInt**, or 2-state packed **vpiStructVar** or **vpiUnionVar** elements). The **vpiRawFourStateVal** or **vpiVectorVal** formats can also be requested of a 2-state array type, and the **vpiRawTwoStateVal** format can be requested for a 4-state array type. The bit values in each array element, whether fixed or variable width, correspond to significance order in *avalbits* and *bvalbits*. That is, the lsb of *rawvals[0]* and *rawvals[nrgroups]* indicates the A and B value of the lsb (0th) bit of the first array element, respectively, and the lsb of *rawvals[1]* and *rawvals[nrgroups+1]* indicates the A and B value of bit 8 of the first array element (if it is of width 9 bits or greater), and so on. Similar significance order conventions apply to A/B word groups in the **vpiVectorVal** format, as described for **vpi_get_value()** (38.15).

The *index_p* argument is an array containing the indices of the starting element to be retrieved in the array object. The indices are ordered in this array according to left-to-right order they would appear in an expression in HDL text. The size of the *index_p* index array shall be equal to the number of unpacked dimensions of *obj*, the array object.

The array element values are retrieved consecutively in order of the fastest varying index (rightmost unpacked range of the array declaration), followed by more slowly varying indices accordingly until the number of elements (*num*) has been retrieved. Index values within each range are ordered from leftmost range value to rightmost. For example, elements of an array *a[2:0][3:5]* with *index_p[0] = 1* and *index_p[1] = 4* would be retrieved in the order *a[1][4]*, *a[1][5]*, *a[0][3]*, *a[0][4]*, *a[0][5]*, respectively.

By default, array values shall be returned in memory allocated by VPI (in which case the storage should be regarded as read-only). In this case, since the same VPI storage area may be overwritten with subsequent calls to this function, the caller must save this data elsewhere in order to preserve it.

However, if the application sets the **vpiUserAllocFlag** in the *value.flags* field, the function will assume the calling application has set the *value* field to point to a buffer of sufficient size allocated by the application for placing the values. For all formats requested except for **vpiRawFourStateVal**, **vpiVectorVal**, and **vpiRawTwoStateVal**, the buffer size can be simply computed as:

```
size = num * sizeof(<union ptr type>);
```

For example, a buffer sized to hold an array of small integers (of **vpiByteVar** or **vpiShortIntVar** elements) using the **vpiShortIntVal** format type set would be sized as:

```
size = num * sizeof(PLI_INT16);
```

Buffers allocated to hold the **vpiRawFourStateVal** and **vpiRawTwoStateVal** formats shall be sized according to the instructions in their format description.

If **vpi_get_value_array()** returns **NULL** for the value pointer in either case, it shall indicate that a VPI error has occurred in the retrieval process. It shall be the application's responsibility to free memory it has allocated, even if a VPI error has occurred (when the value field pointer is overwritten to **NULL**). The application should always save the value of the pointer to memory it allocates so that it can be freed later.

Using the previous example of array **a**, the following code could be used to retrieve the five values shown above starting at **a[1][4]** (with the application code allocating the storage for them):

```
/* Retrieve 5 element values from array "logic a[2:0][3:5]"
 * starting at "a[1][4]", given "arrH", a vpiHandle for "a". */
int indexArr[2];
PLI_BYTE8 *valueBuffer; /* Retain local ptr to mem allocated */
s_vpi_arrayvalue arrayVal = { 0, 0, NULL };
vpiHandle elemH, elemI;
int elemWidth, ngroups;
int num = 5;

/* Get array element so we can get size to determine ngroups */
elemI = vpi_iterate(vpiReg, arrH);
elemH = vpi_scan(elemI);
elemWidth = vpi_get(vpiSize, elemH);
ngroups = (elemWidth + 7) / 8;
vpi_release_handle(elemI);

/* Allocate storage and retrieve the values. */
arrayVal.format = vpiRawFourStateVal;
arrayVal.flags |= vpiUserAllocFlag; /* We allocate the memory */
valueBuffer = (PLI_BYTE8 *)malloc(ngroups * 2 * num);
arrayVal.value.rawvals = valueBuffer;
indexArr[0] = 1;
indexArr[1] = 4;
vpi_get_value_array(arrH, &arrayVal, indexArr, num);

/* Check for result status */
if (arrayVal.value.rawvals == NULL) {
    /* ... We have an error- check it. ... */
} else {
    /* ... Values OK- process them. ... */
}
free(valueBuffer);
```

38.17 vpi_get_vlog_info()

vpi_get_vlog_info()			
Synopsis:	Retrieve information about SystemVerilog simulation execution.		
Syntax:	<code>vpi_get_vlog_info(vlog_info_p)</code>		
	Type	Description	
Returns:	PLI_INT32	1 (true) on success; 0 (false) on failure.	
	Type	Name	Description
Arguments:	<code>p_vpi_vlog_info</code>	<code>vlog_info_p</code>	Pointer to a structure containing simulation information.
Related routines:			

The VPI routine **vpi_get_vlog_info()** shall obtain the following information about SystemVerilog tool execution:

- The number of invocation options (*argc*)
- Invocation option values (*argv*)
- Product and version strings

The information shall be contained in an `s_vpi_vlog_info` structure. The routine shall return 1 (true) on success and 0 (false) on failure.

The `s_vpi_vlog_info` structure used by **vpi_get_vlog_info()** is defined in `vpi_user.h` and is listed in [Figure 38-10](#).

```
typedef struct t_vpi_vlog_info
{
    PLI_INT32 argc;
    PLI_BYTE8 **argv;
    PLI_BYTE8 *product;
    PLI_BYTE8 *version;
} s_vpi_vlog_info, *p_vpi_vlog_info;
```

Figure 38-10—s_vpi_vlog_info structure definition

The format of the *argv* array is that each pointer in the array shall point to a NULL-terminated character array that contains the string located on the tool's invocation command line. There shall be *argc* entries in the *argv* array. The value in entry zero shall be the tool's name.

The vendor tool may provide a command-line option to pass a file containing a set of options. In that case, the argument strings returned by **vpi_get_vlog_info()** shall contain the vendor option string name followed by a pointer to a NULL-terminated array of pointers to characters. This new array shall contain the parsed contents of the file. The value in entry zero shall contain the name of the file. The remaining entries shall contain pointers to NULL-terminated character arrays containing the different options in the file. The last entry in this array shall be NULL. If one of the options is the vendor file option, then the next pointer shall behave the same as described above.

38.18 vpi_handle()

vpi_handle()			
Synopsis:	Obtain a handle to an object with a one-to-one relationship.		
Syntax:	<code>vpi_handle (type, ref)</code>		
	Type	Description	
Returns:	vpiHandle	Handle to an object.	
	Type	Name	Description
Arguments:	PLI_INT32	type	An integer constant representing the type of object for which to obtain a handle.
	vpiHandle	ref	Handle to a reference object.
Related routines:	Use <code>vpi_iterate()</code> and <code>vpi_scan()</code> to obtain handles to objects with a one-to-many relationship. Use <code>vpi_handle_multi()</code> to obtain a handle to an object with a many-to-one relationship.		

The VPI routine **vpi_handle()** shall return the object of type *type* associated with object *ref*. Unless otherwise specified, calling **vpi_handle()** for a protected object shall be an error. The one-to-one relationships that are traversed with this routine are indicated as single arrows in the data model diagrams.

The following example application displays each primitive that an input net drives:

```
void display_driven_primitives(net)
vpiHandle net;
{
    vpiHandle load, prim, itr;
    vpi_printf("Net %s drives terminals of the primitives: \n",
vpi_get_str(vpiFullName, net));
    itr = vpi_iterate(vpiLoad, net);
    if (!itr)
        return;
    while (load = vpi_scan(itr))
    {
        switch(vpi_get(vpiType, load))
        {
            case vpiGate:
            case vpiSwitch:
            case vpiUdp:
                prim = vpi_handle(vpiPrimitive, load);
                vpi_printf("\t%s\n", vpi_get_str(vpiFullName, prim));
            }
        }
    }
}
```

38.19 vpi_handle_by_index()

vpi_handle_by_index()			
Synopsis:	Get a handle to an object using its index number within a parent object.		
Syntax:	vpi_handle_by_index(obj, index)		
	Type	Description	
Returns:	vpiHandle	Handle to an object.	
	Type	Name	Description
Arguments:	vpiHandle	obj	Handle to an object.
	PLI_INT32	index	Index number of the object for which to obtain a handle.
Related routines:			

The VPI routine **vpi_handle_by_index()** shall return a handle to an object based on the index number of the object within the reference object, *obj*. The reference object shall be an object that has the **access by index** property. Unless otherwise specified, calling **vpi_handle_by_index()** for a protected object shall be an error. For example, to access a net bit, *obj* would be the associated net; to access an element of a reg array, *obj* would be the array. If the selection represented by the index number does not lead to the construction of a legal SystemVerilog index select expression, the routine shall return a `null` handle.

38.20 vpi_handle_by_multi_index()

vpi_handle_by_multi_index()			
Synopsis:	Obtain a handle to a subobject using an array of indices and a reference object.		
Syntax:	vpi_handle_by_multi_index(obj, num_index, index_array)		
	Type	Description	
Returns:	vpiHandle	Handle to an object.	
	Type	Name	Description
Arguments:	vpiHandle	obj	Handle to an object.
	PLI_INT32	num_index	Number of indices in the index array.
	PLI_INT32 *	index_array	Array of indices. Leftmost index first.
Related routines:			

The VPI routine **vpi_handle_by_multi_index()** shall provide access to an index-selected subobject of the reference handle. The reference object shall be an object that has the **access by index** property. Unless otherwise specified, calling **vpi_handle_by_multi_index()** for a protected object shall be an error. This routine shall return a handle to a valid SystemVerilog object based on the list of indices provided by the argument *index_array* and reference handle denoted by *obj*. The argument *num_index* shall contain the number of indices in the provided array *index_array*.

The order of the indices provided shall follow the array dimension declaration from the leftmost range to the rightmost range of the reference handle; the array indices may be optionally followed by a bit-select index. If the indices provided do not lead to the construction of a legal SystemVerilog index select expression, the routine shall return a `null` handle.

38.21 `vpi_handle_by_name()`

vpi_handle_by_name()			
Synopsis:	Get a handle to an object with a specific name.		
Syntax:	<code>vpi_handle_by_name(name, scope)</code>		
	Type	Description	
Returns:	<code>vpiHandle</code>	Handle to an object.	
	Type	Name	Description
Arguments:	<code>PLI_BYTE8 *</code>	<code>name</code>	A character string or pointer to a string containing the name of an object.
	<code>vpiHandle</code>	<code>scope</code>	Handle to a SystemVerilog scope.
Related routines:			

The VPI routine `vpi_handle_by_name()` shall return a handle to an object with a specific name. This function can be applied to all objects with a *fullname* property. The *name* can be hierarchical or simple. If *scope* is `NULL`, then *name* shall be searched for from the top level of hierarchy. If a scope object is provided, then search within that scope only. Unless otherwise specified, calling `vpi_handle_by_name()` for a protected scope object shall be an error. If the *name* is hierarchical and includes a protected scope, the call shall be an error.

38.22 vpi_handle_multi()

vpi_handle_multi()			
Synopsis:	Obtain a handle for an object in a many-to-one relationship.		
Syntax:	vpi_handle_multi(type, ref1, ref2, ...)		
	Type	Description	
Returns:	vpiHandle	Handle to an object.	
	Type	Name	Description
Arguments:	PLI_INT32	type	An integer constant representing the type of object for which to obtain a handle.
	vpiHandle	ref1, ref2, ...	Handles to two or more reference objects.
Related routines:	Use vpi_iterate() and vpi_scan() to obtain handles to objects with a one-to-many relationship. Use vpi_handle() to obtain handles to objects with a one-to-one relationship.		

The VPI routine **vpi_handle_multi()** can be used to return a handle to an object of type **vpiInterModPath** associated with a list of *output port* and *input port* reference objects. The ports shall be of the same size and can be at different levels of the hierarchy.

38.23 vpi_iterate()

vpi_iterate()			
Synopsis:	Obtain an iterator handle to objects with a one-to-many relationship.		
Syntax:	vpi_iterate(type, ref)		
	Type	Description	
Returns:	vpiHandle	Handle to an iterator for an object.	
	Type	Name	Description
Arguments:	PLI_INT32	type	An integer constant representing the type of object for which to obtain iterator handles.
	vpiHandle	ref	Handle to a reference object.
Related routines:	Use vpi_scan() to traverse the design hierarchy using the iterator handle returned from vpi_iterate(). Use vpi_handle() to obtain handles to object with a one-to-one relationship. Use vpi_handle_multi() to obtain a handle to an object with a many-to-one relationship.		

The VPI routine **vpi_iterate()** shall be used to traverse one-to-many relationships, which are indicated as double arrows in the data model diagrams. Unless otherwise specified, calling **vpi_iterate()** for a protected object shall be an error. The **vpi_iterate()** routine shall return a handle to an iterator, whose type shall be **vpiiterator**, which can be used by **vpi_scan()** to traverse all objects of type *type* associated with object *ref*. To get the reference object from the iterator object, use **vpi_handle(vpiUse, iterator_handle)**. If there are no objects of type *type* associated with the reference handle *ref*, then the **vpi_iterate()** routine shall return NULL.

The following example application uses **vpi_iterate()** and **vpi_scan()** to display each net (including the size for vectors) declared in the module. The example assumes it shall be passed a valid module handle.

```

void display_nets(mod)
vpiHandle mod;
{
    vpiHandle net;
    vpiHandle itr;

    vpi_printf("Nets declared in module %s\n",
vpi_get_str(vpiFullName, mod));

    itr = vpi_iterate(vpiNet, mod);
    while (net = vpi_scan(itr))
    {
        vpi_printf("\t%s", vpi_get_str(vpiName, net));
        if (vpi_get(vpiVector, net))
        {
            vpi_printf(" of size %d\n", vpi_get(vpiSize, net));
        }
        else vpi_printf("\n");
    }
}

```

38.24 vpi_mcd_close()

vpi_mcd_close()			
Synopsis:	Close one or more files opened by vpi_mcd_open().		
Syntax:	vpi_mcd_close(mcd)		
	Type	Description	
Returns:	PLI_UINT32	0 if successful; the <i>mcd</i> of unclosed channels if unsuccessful.	
	Type	Name	Description
Arguments:	PLI_UINT32	mcd	A multichannel descriptor representing the files to close.
Related routines:	Use vpi_mcd_open() to open a file. Use vpi_mcd_printf() to write to an opened file. Use vpi_mcd_vprintf() to write a variable number of arguments to an opened file. Use vpi_mcd_flush() to flush a file output buffer. Use vpi_mcd_name() to get the name of a file represented by a channel descriptor.		

The VPI routine **vpi_mcd_close()** shall close the file(s) specified by a multichannel descriptor, *mcd*. Several channels can be closed simultaneously because channels are represented by discrete bits in the integer *mcd*. On success, this routine shall return a 0; on error, it shall return the *mcd* value of the unclosed channels. This routine can also be used to close file descriptors that were opened using the system function **\$fopen**. See [21.3.1](#) for the functional description of **\$fopen**.

The following descriptor is predefined and cannot be closed using **vpi_mcd_close()**:

- descriptor 1 is for the output channel of the tool that invoked the PLI application and the current log file

38.25 vpi_mcd_flush()

vpi_mcd_flush()			
Synopsis:	Flushes the data from the given <i>mcd</i> output buffers.		
Syntax:	<code>vpi_mcd_flush(mcd)</code>		
	Type	Description	
Returns:	PLI_INT32	0 if successful; nonzero if unsuccessful.	
	Type	Name	Description
Arguments:	PLI_UINT32	<code>mcd</code>	A multichannel descriptor representing the files to which to write.
Related routines:	Use <code>vpi_mcd_printf()</code> to write a finite number of arguments to an opened file. Use <code>vpi_mcd_vprintf()</code> to write a variable number of arguments to an opened file. Use <code>vpi_mcd_open()</code> to open a file. Use <code>vpi_mcd_close()</code> to close a file. Use <code>vpi_mcd_name()</code> to get the name of a file represented by a channel descriptor.		

The routine **vpi_mcd_flush()** shall flush the output buffers for the file(s) specified by the multichannel descriptor *mcd*.

38.26 vpi_mcd_name()

vpi_mcd_name()			
Synopsis:	Get the name of a file represented by a channel descriptor.		
Syntax:	<code>vpi_mcd_name(cd)</code>		
	Type	Description	
Returns:	PLI_BYTE8 *	Pointer to a character string containing the name of a file.	
	Type	Name	Description
Arguments:	PLI_UINT32	<code>cd</code>	A channel descriptor representing a file.
Related routines:	Use <code>vpi_mcd_open()</code> to open a file. Use <code>vpi_mcd_close()</code> to close files. Use <code>vpi_mcd_printf()</code> to write to an opened file. Use <code>vpi_mcd_flush()</code> to flush a file output buffer. Use <code>vpi_mcd_vprintf()</code> to write a variable number of arguments to an opened file.		

The VPI routine **vpi_mcd_name()** shall return the name of a file represented by a single-channel descriptor, *cd*. On error, the routine shall return `NULL`. This routine shall overwrite the returned value on subsequent calls. If the application needs to retain the string, it should copy it. This routine can be used to get the name of any file opened using the system function `$fopen` or the VPI routine **vpi_mcd_open()**. The channel descriptor *cd* could be an *fd* file descriptor returned from `$fopen` (indicated by the most significant bit being set) or an *mcd* multichannel descriptor returned by either the system function `$fopen` or the VPI routine **vpi_mcd_open()**. See [21.3.1](#) for the functional description of `$fopen`.

38.27 vpi_mcd_open()

vpi_mcd_open()			
Synopsis:	Open a file for writing.		
Syntax:	vpi_mcd_open(<i>file</i>)		
	Type	Description	
Returns:	PLI_UINT32	A multichannel descriptor representing the file that was opened.	
	Type	Name	Description
Arguments:	PLI_BYTE8 *	file	A character string or pointer to a string containing the file name to be opened.
Related routines:	Use vpi_mcd_close() to close a file. Use vpi_mcd_printf() to write to an opened file. Use vpi_mcd_vprintf() to write a variable number of arguments to an opened file. Use vpi_mcd_flush() to flush a file output buffer. Use vpi_mcd_name() to get the name of a file represented by a channel descriptor.		

The VPI routine **vpi_mcd_open()** shall open a file for writing and shall return a corresponding multichannel description number (*mcd*). The channel descriptor 1 (least significant bit) is reserved for representing the output channel of the tool that invoked the PLI application and the log file (if one is currently open). The channel descriptor 32 (most significant bit) is reserved to represent a file descriptor (*fd*) returned from the SystemVerilog **\$fopen** system function.

The *mcd* descriptor returned by **vpi_mcd_open()** routine is compatible with the *mcd* descriptors returned from the **\$fopen** system function. The *mcd* descriptors returned from **vpi_mcd_open()** and from **\$fopen** may be shared between the built-in system tasks that use *mcd* descriptors and the VPI routines that use *mcd* descriptors. If the most significant bit of the return value from **\$fopen** is set, then the value is an *fd* file descriptor, which is not compatible with the *mcd* descriptor returned by **vpi_mcd_open()**. See [21.3.1](#) for the functional description of **\$fopen**.

The **vpi_mcd_open()** routine shall return a 0 on error. If the file has already been opened either by a previous call to **vpi_mcd_open()** or using **\$fopen** in the SystemVerilog source code, then **vpi_mcd_open()** shall return the descriptor number.

38.28 vpi_mcd_printf()

vpi_mcd_printf()			
Synopsis:	Write to one or more files opened with vpi_mcd_open() or \$fopen.		
Syntax:	vpi_mcd_printf(mcd, format, ...)		
	Type	Description	
Returns:	PLI_INT32	The number of characters written.	
	Type	Name	Description
Arguments:	PLI_UINT32	mcd	A multichannel descriptor representing the files to which to write.
	PLI_BYTE8 *	format	A format string using the C fprintf() format.
Related routines:	Use vpi_mcd_vprintf() to write a variable number of arguments to an opened file. Use vpi_mcd_open() to open a file. Use vpi_mcd_close() to close a file. Use vpi_mcd_flush() to flush a file output buffer. Use vpi_mcd_name() to get the name of a file represented by a channel descriptor.		

The VPI routine **vpi_mcd_printf()** shall write to one or more channels (up to 31) determined by the *mcd*. An *mcd* of 1 (bit 0 set) corresponds to the channel 1, an *mcd* of 2 (bit 1 set) corresponds to channel 2, an *mcd* of 4 (bit 2 set) corresponds to channel 3, and so on. Channel 1 is reserved for the output channel of the tool that invoked the PLI application and the current log file. The most significant bit of the descriptor is reserved by the tool to indicate that the descriptor is actually a file descriptor instead of an *mcd*. **vpi_mcd_printf()** shall also write to a file represented by an *mcd* that was returned from the SystemVerilog **\$fopen** system function. **vpi_mcd_printf()** shall not write to a file represented by an *fd* file descriptor returned from **\$fopen** (indicated by the most significant bit being set). See [21.3.2](#) for the functional description of **\$fopen**.

Several channels can be written to simultaneously because channels are represented by discrete bits in the integer *mcd*.

The text written shall be controlled by one or more format strings. The format strings shall use the same format as the C fprintf() routine. The routine shall return the number of characters printed or return EOF if an error occurred.

38.29 vpi_mcd_vprintf()

vpi_mcd_vprintf()			
Synopsis:	Write to one or more files opened with vpi_mcd_open() or \$fopen using varargs that are already started.		
Syntax:	vpi_mcd_vprintf(mcd, format, ap)		
	Type	Description	
Returns:	PLI_INT32	The number of characters written.	
	Type	Name	Description
Arguments:	PLI_UINT32	mcd	A multichannel descriptor representing the files to which to write.
	PLI_BYTE8 *	format	A format string using the C printf() format.
	va_list	ap	An already started varargs list.
Related routines:	Use vpi_mcd_printf() to write a finite number of arguments to an opened file. Use vpi_mcd_open() to open a file. Use vpi_mcd_close() to close a file. Use vpi_mcd_flush() to flush a file output buffer. Use vpi_mcd_name() to get the name of a file represented by a channel descriptor.		

This routine performs the same function as **vpi_mcd_printf()**, except that varargs have already been started.

38.30 vpi_printf()

vpi_printf()			
Synopsis:	Write to the output channel of the tool that invoked the PLI application and the current tool log file.		
Syntax:	vpi_printf(format, ...)		
	Type	Description	
Returns:	PLI_INT32	The number of characters written.	
	Type	Name	Description
Arguments:	PLI_BYTE8 *	format	A format string using the C printf() format.
Related routines:	Use vpi_vprintf() to write a variable number of arguments. Use vpi_mcd_printf() to write to an opened file. Use vpi_mcd_flush() to flush a file output buffer. Use vpi_mcd_vprintf() to write a variable number of arguments to an opened file.		

The VPI routine **vpi_printf()** shall write to both the output channel of the tool that invoked the PLI application and the current tool log file. The format string shall use the same format as the C printf() routine. The routine shall return the number of characters printed or return EOF if an error occurred.

38.31 vpi_put_data()

vpi_put_data()			
Synopsis:	Put data into an implementation's save/restart location.		
Syntax:	vpi_put_data(id, dataLoc, numOfBytes)		
	Type	Description	
Returns:	PLI_INT32	The number of bytes written.	
	Type	Name	Description
Arguments:	PLI_INT32	id	A save/restart ID returned from vpi_get(vpiSaveRestartID, NULL).
	PLI_BYTE8 *	dataLoc	Address of application-allocated storage.
	PLI_INT32	numOfBytes	Number of bytes to be added to save/restart location.
Related routines:	Use vpi_get_data() to retrieve saved data.		

This routine shall place **numOfBytes**, which shall be greater than zero, of data located at **dataLoc** into an implementation's save/restart location. The return value shall be the number of bytes written. A zero shall be returned if an error is detected. There shall be no restrictions on the following:

- How many times the routine can be called for a given *id*
- The order applications put data using the different *ids*

The data from multiple calls to **vpi_put_data()** with the same *id* shall be stored by the simulator in such a way that the opposing routine **vpi_get_data()** can pull data out of the save/restart location using different sizes of chunks. This routine can only be called from an application routine that has been called for the reason **cbStartOfSave** or **cbEndOfSave**. An application can get the path to the implementation's save/restart location by calling **vpi_get_str(vpiSaveRestartLocation, NULL)** from an application callback routine that has been called for reason **cbStartOfSave** or **cbEndOfSave**.

The following example illustrates using **vpi_put_data()** and **vpi_get_data()**:

```
#include <stdlib.h>
#include <assert.h>
#include "vpi_user.h"

typedef struct myStruct *myStruct_p;
typedef struct myStruct {
    PLI_INT32 d1;
    PLI_INT32 d2;
    myStruct_p next;
} myStruct_s;

static myStruct_p firstWrk = NULL;

PLI_INT32 consumer_restart(p_cb_data data)
{
    struct myStruct *wrk;
    PLI_INT32 status;
    PLI_INT32 cnt, size;
    PLI_INT32 id = (PLI_INT32) data->user_data;
```

```
/* Get the number of structures */

status = vpi_get_data(id, (PLI_BYTE8 *) &cnt, sizeof(PLI_INT32));
assert(status > 0); /* Check returned status */

/* allocate memory for the structures */

size = cnt * sizeof(struct myStruct);
firstWrk = (myStruct_p) malloc(size);

/* retrieve the data structures */

if (cnt != vpi_get_data(id, (PLI_BYTE8 *) firstWrk, cnt))
    return(1); /* error */

firstWrk = wrk;

/* Fix the next pointers in the linked list */

for (wrk = firstWrk; cnt > 0; cnt--)
{
    wrk->next = wrk + 1;
    wrk = wrk->next;
}
wrk->next = NULL;
return(0); /* SUCCESS */
}

PLI_INT32 consumer_save(p_cb_data data)
{
    myStruct_p wrk;
    s_cb_data cbData;
    vpiHandle cbHdl;
    PLI_INT32 id = 0;
    PLI_INT32 cnt = 0;

    /* Get the number of structures */

    wrk = firstWrk;
    while (wrk)
    {
        cnt++;
        wrk = wrk->next;
    }

    /* now save the data */

    wrk = firstWrk;
    id = vpi_get(vpiSaveRestartID, NULL);

    /* save the number of data structures */

    vpi_put_data(id, (PLI_BYTE8 *) cnt, sizeof(PLI_INT32));

    /* Save the different data structures. Note that a pointer
     * is being saved. While this is allowed, an application
     * must change it to something useful on a restart.
     */
}
```

```

while (wrk)
{
    vpi_put_data(id, (PLI_BYTE8 *)wrk, sizeof(myStruct_s));
    wrk = wrk->next;
}

/* register a call for restart */
/* We need the "id" so that the saved data can be retrieved.
 * Using the user_data field of the callback structure is the
 * easiest way to pass this information to retrieval operation.
 */

cbData.user_data = (PLI_BYTE8 *)id;
cbData.reason = cbStartOfRestart;

/* See 38.9 vpi\_get\_data\(\) for a description of how
 * the callback routine can be used to retrieve the data.
 */

cbData.cb_rtn = consumer_restart;

cbData.value = NULL;
cbData.time = NULL;
cbHdl = vpi_register_cb(&cbData);
vpi_release_handle(cbHdl);
return(0);
}
    
```

38.32 vpi_put_delays()

vpi_put_delays()			
Synopsis:	Set the delays or timing limits of an object.		
Syntax:	vpi_put_delays(obj, delay_p)		
Returns:	Type	Description	
	void		
Arguments:	Type	Name	Description
	vpiHandle	obj	Handle to an object.
	p_vpi_delay	delay_p	Pointer to a structure containing delay information.
Related routines:	Use vpi_get_delays() to retrieve delays or timing limits of an object.		

The VPI routine **vpi_put_delays()** shall set the delays or timing limits of an object as indicated in the *delay_p* structure. The same ordering of delays shall be used as described in the **vpi_get_delays()** function. If only the delay changes and not the pulse limits, the pulse limits shall retain the values they had before the delays where altered.

The *s_vpi_delay* and *s_vpi_time* structures used by both **vpi_get_delays()** and **vpi_put_delays()** are defined in *vpi_user.h* and are listed in [Figure 38-11](#) and [Figure 38-12](#).

```
typedef struct t_vpi_delay
{
    struct t_vpi_time *da; /* pointer to application-allocated
                           array of delay values*/
    PLI_INT32 no_of_delays; /* number of delays */
    PLI_INT32 time_type; /* [vpiScaledRealTime,vpiSimTime,
                           vpiSuppresTime]*/
    PLI_INT32 mtm_flag; /* true for mtm values */
    PLI_INT32 append_flag; /* true for append */
    PLI_INT32 pulserē_flag; /* true for pulserē values */
} s_vpi_delay, *p_vpi_delay;
```

Figure 38-11—s_vpi_delay structure definition

```
typedef struct t_vpi_time
{
    PLI_INT32 type; /* [vpiScaledRealTime, vpiSimTime, vpiSuppresTime] */
    PLI_UINT32 high, low; /* for vpiSimTime */
    double real; /* for vpiScaledRealTime */
} s_vpi_time, *p_vpi_time;
```

Figure 38-12—s_vpi_time structure definition

The *da* field of the *s_vpi_delay* structure shall be an application-allocated array of *s_vpi_time* structures. This array stores the delay values to be written by *vpi_put_delays()*. The number of elements in this array is determined by the following:

- The number of delays to be written
- The **mtm_flag** setting
- The **pulserē_flag** setting

The number of delays to be set shall be set in the *no_of_delays* field of the *s_vpi_delay* structure. Legal values for the number of delays shall be determined by the type of object:

- For primitive objects, the *no_of_delays* value shall be 2 or 3.
- For path delay objects, the *no_of_delays* value shall be 1, 2, 3, 6, or 12.
- For timing check objects, the *no_of_delays* value shall match the number of limits existing in the timing check.
- For intermodule path objects, the *no_of_delays* value shall be 2 or 3.

The application-allocated *s_vpi_delay* array shall contain delays in the same order in which they occur in the SystemVerilog source description. The number of elements for each delay shall be determined by the flags **mtm_flag** and **pulserē_flag**, as shown in [Table 38-4](#).

Table 38-4—Size of the s_vpi_delay->da array

Flag values	Number of s_vpi_time array elements required for s_vpi_delay->da	Order in which delay elements shall be filled
mtm_flag = FALSE pulserē_flag = FALSE	<i>no_of_delays</i>	1st delay: da[0] -> 1st delay 2nd delay: da[1] -> 2nd delay ...
mtm_flag = TRUE pulserē_flag = FALSE	3 * <i>no_of_delays</i>	1st delay: da[0] -> min delay da[1] -> typ delay da[2] -> max delay 2nd delay: ...

Table 38-4—Size of the s_vpi_delay->da array (continued)

Flag values	Number of s_vpi_time array elements required for s_vpi_delay->da	Order in which delay elements shall be filled
mtm_flag = FALSE pulsere_flag = TRUE	3 * <i>no_of_delays</i>	1st delay: da[0] -> delay da[1] -> reject limit da[2] -> error limit 2nd delay element: ...
mtm_flag = TRUE pulsere_flag = TRUE	9 * <i>no_of_delays</i>	1st delay: da[0] -> min delay da[1] -> typ delay da[2] -> max delay da[3] -> min reject da[4] -> typ reject da[5] -> max reject da[6] -> min error da[7] -> typ error da[8] -> max error 2nd delay: ...

The following example application accepts a module path handle, rise and fall delays, and replaces the delays of the indicated path:

```
void set_path_rise_fall_delays(path, rise, fall)
vpiHandle path;
double rise, fall;
{
    static s_vpi_time path_da[2];
    static s_vpi_delay delay_s = {NULL, 2, vpiScaledRealTime};
    static p_vpi_delay delay_p = &delay_s;

    delay_s.da = path_da;
    path_da[0].real = rise;
    path_da[1].real = fall;
    vpi_put_delays(path, delay_p);
}
```

38.33 vpi_put_userdata()

vpi_put_userdata()			
Synopsis:	Put user-data value into an implementation's system task or system function instance storage location.		
Syntax:	<code>vpi_put_userdata(obj, userdata)</code>		
	Type	Description	
Returns:	PLI_INT32	1 on success; 0 if an error occurs.	
	Type	Name	Description
Arguments:	vpiHandle	obj	Handle to a system task instance or system function instance.
	void *	userdata	User-data value to be associated with the system task instance or system function instance.
Related routines:	Use <code>vpi_get_userdata()</code> to retrieve the user-data value.		

This routine will associate the value of the input *userdata* with the specified user-defined system task or system function call handle. The stored value can later be retrieved with the routine `vpi_get_userdata()`. The routine will return a value of 1 on success or a 0 if it fails.

After a restart or a reset, subsequent calls to `vpi_get_userdata()` shall return `NULL`. It is the application's responsibility to save the data during a save using `vpi_put_data()` and to then retrieve it using `vpi_get_data()`. The user-data field can be set up again during or after callbacks of type `cbEndOfRestart` or `cbEndOfReset`.

38.34 vpi_put_value()

vpi_put_value()			
Synopsis:	Set a value on an object.		
Syntax:	<code>vpi_put_value(obj, value_p, time_p, flags)</code>		
	Type	Description	
Returns:	vpiHandle	Handle to the scheduled event caused by <code>vpi_put_value()</code> .	
	Type	Name	Description
Arguments:	vpiHandle	obj	Handle to an object.
	p_vpi_value	value_p	Pointer to a structure with value information.
	p_vpi_time	time_p	Pointer to a structure with delay information.
	PLI_INT32	flags	Integer constants that set the delay mode.
Related routines:	Use <code>vpi_get_value()</code> to retrieve the value of an expression.		

The VPI routine `vpi_put_value()` shall set simulation logic values on an object. The value to be set shall be stored in an `s_vpi_value` structure that has been allocated by the calling routine. Any storage referenced

by the `s_vpi_value` structure shall also be allocated by the calling routine. The legal values that may be specified for each value format are listed in [Table 38-3](#) in [38.15](#). The delay time before the value is set shall be stored in an `s_vpi_time` structure that has been allocated by the calling routine. The routine can be applied to nets, variables, variable selects, memory words, named events, system function calls, sequential UDPs, and scheduled events. The *flags* argument shall be used to direct the routine to use one of the following delay modes:

- vpiInertialDelay** All scheduled events on the object shall be removed before this event is scheduled.
- vpiTransportDelay** All events on the object scheduled for times later than this event shall be removed (modified transport delay).
- vpiPureTransportDelay** No events on the object shall be removed (transport delay).
- vpiNoDelay** The object shall be set to the passed value with no delay. Argument *time_p* shall be ignored and can be set to `NULL`.
- vpiForceFlag** The object shall be forced to the passed value with no delay (same as the SystemVerilog procedural **force**). Argument *time_p* shall be ignored and can be set to `NULL`.
- vpiReleaseFlag** The object shall be released from a forced value (same as the SystemVerilog procedural **release**). Argument *time_p* shall be ignored and can be set to `NULL`. The *value_p* shall be updated with the value of the object after its release. If the value is a string, time, vector, strength, or miscellaneous value, the data pointed to by the *value_p* argument shall be owned by the interface.
- vpiCancelEvent** A previously scheduled event shall be cancelled. The object passed to **vpi_put_value()** shall be a handle to an object of type **vpiSchedEvent**.

If the *flags* argument also has the bit mask **vpiReturnEvent**, **vpi_put_value()** shall return a handle of type **vpiSchedEvent** to the newly scheduled event, provided there is some form of a delay and an event is scheduled. If the bit mask is not used, or if no delay is used, or if an event is not scheduled, the return value shall be `NULL`.

A scheduled event can be cancelled by calling **vpi_put_value()** with *obj* set to the **vpiSchedEvent** handle and *flags* set to **vpiCancelEvent**. The *value_p* and *time_p* arguments to **vpi_put_value()** are not needed for cancelling an event and can be set to `NULL`. It shall not be an error to cancel an event that has already occurred. The scheduled event can be tested by calling **vpi_get()** with the flag **vpiScheduled**. If an event is cancelled, it shall simply be removed from the event queue. Any effects that were caused by scheduling the event shall remain in effect (e.g., events that were cancelled due to inertial delay). Cancelling an event shall also free the handle to that event.

Calling **vpi_release_handle()** on the handle shall free the handle, but shall not affect the event.

When **vpi_put_value()** is called for an object of type **vpiNet** or **vpiNetBit**, and with modes of **vpiInertialDelay**, **vpiTransportDelay**, **vpiPureTransportDelay**, or **vpiNoDelay**, the value supplied overrides the resolved value of the net. This value shall remain in effect until one of the drivers of the net changes value. When this occurs, the net shall be reevaluated using the normal resolution algorithms.

It shall be illegal to specify the format of the value as **vpiStringVal** when putting a value to a real variable or a system function call of type **vpiRealFunc**. It shall be illegal to specify the format of the value as **vpiStrengthVal** when putting a value to a vector object.

When **vpi_put_value()** with a **vpiForce** flag is used, it shall perform a procedural force of a value onto the same types of objects as supported by a procedural force. A **vpiRelease** flag shall release the forced value. This shall be the same functionality as the procedural **force** and **release** keywords in SystemVerilog (see [10.6.2](#)).

Sequential UDPs shall be set to the indicated value with no delay regardless of any delay on the primitive instance. Putting values to UDP instances shall be done using the **vpiNoDelay** flag. Attempting to use the other delay modes shall result in an error.

Calling **vpi_put_value()** on an object of type **vpiNamedEvent** shall cause the named event to toggle. Objects of type **vpiNamedEvent** shall not require an actual value, and the *value_p* argument may be NULL.

The **vpi_put_value()** routine shall also return the value of a system function by passing a handle to the user-defined system function as the object handle. This should only occur during execution of the *calltf* routine for the system function. Attempts to use **vpi_put_value()** with a handle to the system function when the *calltf* routine is not active shall be ignored. Should the *calltf* routine for a user-defined system function fail to put a value during its execution, the default value of 0 will be applied. Putting return values to system functions shall be done using the **vpiNoDelay** flag.

The **vpi_put_value()** routine shall only return a system function value in a *calltf* application when the call to the system function is active. The action of **vpi_put_value()** to a system function shall be ignored when the system function is not active. Putting values to system function shall be done using the **vpiNoDelay** flag.

The *s_vpi_value* and *s_vpi_time* structures used by **vpi_put_value()** are defined in *vpi_user.h* and are listed in [Figure 38-13](#) and [Figure 38-14](#).

```
typedef struct t_vpi_value
{
    PLI_INT32 format; /* vpi[[Bin,Oct,Dec,Hex]Str,Scalar,Int,Real,String,
                    Vector,Strength,Suppress,Time,ObjType]Val */
    union
    {
        PLI_BYTE8 *str; /* string value */
        PLI_INT32 scalar; /* vpi[0,1,X,Z] */
        PLI_INT32 integer; /* integer value */
        double real; /* real value */
        struct t_vpi_time *time; /* time value */
        struct t_vpi_vecval *vector; /* vector value */
        struct t_vpi_strengthval *strength; /* strength value */
        PLI_BYTE8 *misc; /* ...other */
    } value;
} s_vpi_value, *p_vpi_value;
```

Figure 38-13—s_vpi_value structure definition

```
typedef struct t_vpi_time
{
    PLI_INT32 type; /* [vpiScaledRealTime, vpiSimTime, vpiSuppressTime] */
    PLI_UINT32 high, low; /* for vpiSimTime */
    double real; /* for vpiScaledRealTime */
} s_vpi_time, *p_vpi_time;
```

Figure 38-14—s_vpi_time structure definition

The *s_vpi_vecval* and *s_vpi_strengthval* structures found in [Figure 38-13](#) are listed in [Figure 38-15](#) and [Figure 38-16](#).

```
typedef struct t_vpi_vecval
{
    /* following fields are repeated enough times to contain vector */
    PLI_UINT32 aval, bval; /* bit encoding: ab: 00=0, 10=1, 11=X, 01=Z */
} s_vpi_vecval, *p_vpi_vecval;
```

Figure 38-15—s_vpi_vecval structure definition

```
typedef struct t_vpi_strengthval
{
    PLI_INT32 logic; /* vpi[0,1,X,Z] */
    PLI_INT32 s0, s1; /* refer to strength coding in Annex K */
} s_vpi_strengthval, *p_vpi_strengthval;
```

Figure 38-16—s_vpi_strengthval structure definition

For **vpiScaledRealTime**, the indicated time shall be in the timescale associated with the object.

38.35 vpi_put_value_array()

vpi_put_value_array()			
Synopsis:	Set values for contiguous elements of a static unpacked array object		
Syntax:	vpi_put_value_array(obj, arrayvalue_p, index_p, num)		
Returns:	Type	Description	
	void		
Arguments:	Type	Name	Description
	vpiHandle	obj	Handle to an unpacked array object.
	p_vpi_arrayvalue	arrayvalue_p	Pointer to a structure containing array value information.
	PLI_INT32 *	index_p	Pointer to an array of index values corresponding to the start of the section of the object to be updated.
	PLI_UINT32	num	Number of array elements to be updated.
Related routines:	Use vpi_get_value_array() to retrieve values of contiguous elements of a static unpacked array object.		

The VPI routine **vpi_put_value_array()** shall modify simulation values of contiguous elements in static unpacked variable or net arrays (array objects for which the **vpiArrayType** property is **vpiStaticArray**). Such arrays must also have static lifetimes and not contain dynamic arrays or dynamic elements (e.g., string vars). For purposes here, the term element corresponds to any indexable member of such an array with all unpacked indices fully specified. The datatype of each element so defined corresponds to the datatype of the array with all unpacked ranges removed. The elements of arrays are not allowed to be of an unpacked type themselves (e.g., unpacked structs).

The values to be set for the array shall be placed in an `s_vpi_arrayvalue` structure allocated by the calling routine. Any storage referenced by the `s_vpi_arrayvalue` structure shall also be allocated by the calling routine. The `s_vpi_arrayvalue` structure is defined in `vpi_user.h`, as follows:

```
typedef struct t_vpi_arrayvalue
{
    PLI_UINT32 format;
    PLI_UINT32 flags;
    union
    {
        PLI_INT32 *integers;
        PLI_INT16 *shortints;
        PLI_INT64 *longints;
        PLI_BYTE8 *rawvals;
        struct t_vpi_vecval *vectors;
        struct t_vpi_time *times;
        double *reals;
        float *shortreals;
    } value;
} s_vpi_arrayvalue, *p_vpi_arrayvalue;
```

The layout of the values to be set shall be specified by the calling routine by setting the format field in the structure. In addition to the format types **vpiIntVal**, **vpiVectorVal**, **vpiTimeVal**, and **vpiRealVal** available with **vpi_get_value()** function ([Table 38-3](#) in [38.15](#)), the following format types can be used:

vpiRawFourStateVal Values to be set for each element must be specified in aval/bval format (similar to 4-state vectors) using the **rawvals* field of the union above, interleaved according to the following structure:

```
struct
{
    PLI_BYTE8 avalbits[ngroups];
    PLI_BYTE8 bvalbits[ngroups];
}
```

Each array element occupies *ngroups*2* bytes stored consecutively as A/B byte groups as shown above. For the first indexed array element, the *avalbits* must begin at *rawvals[0]*, and the *bvalbits* must be at *rawvals[ngroups]*, respectively. The second array element's *avalbits* must begin at *rawvals[ngroups*2]*, and its *bvalbits* at *rawvals[ngroups*3]*, etc. *ngroups* is computed given the array element size in bits (= *elemBits*) as follows:

```
int ngroups = (elemBits + 7) / 8;
```

The total storage required to hold “num” array elements shall be *ngroups * num * 2*.

vpiRawTwoStateVal Values to be set shall be provided similarly to **vpiRawFourStateVal** above (also using the **rawvals* struct member), except that the *bvalbits* byte group shall be omitted. *ngroups* shall be computed similarly also, but the total storage used shall instead be *ngroups * num*.

vpiShortIntVal Values to be set will be provided as an array of “num” short(s), using the **shortints* field in the union in this case. This format is appropriate only for arrays of **vpiShortIntVar**, **vpiIntVar** or **vpiLongIntVar** elements.

vpiLongIntVal Values to be set will be stored as an array of “num” long(s), using the **longints* field in the union in this case. This format is appropriate for arrays of **vpiLongIntVar** elements.

vpiShortRealVal Values to be set will be stored as an array of “num” floats, using the **shortrealvals* field in the union in this case. This format is appropriate only for arrays of **vpiShortRealVar** elements.

The format types **vpiIntVal**, **vpiTimeVal**, **vpiVectorVal**, and **vpiRealVal** that are also available with the **vpi_put_value()** function correspond to similar union member names in `s_vpi_arrayvalue` (converted to pointer values and ending in “s” to indicate they are arrays). For example, selecting the **vpiIntVal** format shall cause an array of 32-bit integer values (set using the `*integers` field) to be loaded into the specified section of the array object. The **vpiVectorVal** format shall assume that an array of consecutive A/B word groups formatted according to the `t_vpi_vecval` structure (Figure 38-8 in 38.15) is to be loaded. The `*vectors` field should be used to provide these values. Given the array element size in bits (`== elemBits`), the number of words of storage to provide data for `num` elements will be:

$$((elemBits + 31) / 32) * 2 * num$$

All other formats not mentioned here are unsupported, and shall result in an error if specified. The **vpiRawFourStateVal** format is appropriate for all 4-state array types (all net arrays, or variable arrays of **vpiLogicVar**, **vpiIntegerVar**, **vpiTimeVar**, or 4-state packed **vpiStructVar** or **vpiUnionVar** elements). The **vpiRawTwoStateVal** format is appropriate for all 2-state array types (variable arrays of **vpiBitVar**, **vpiByteVar**, **vpiShortInt**, **vpiInt**, **vpiLongInt**, or 2-state packed **vpiStructVar** or **vpiUnionVar** elements). If the **vpiRawFourStateVal** format is set for a 2-state array type, the `bvalbits` shall be ignored. If the **vpiRawTwoStateVal** format is specified for a 4-state array type, the `bvalbits` shall be assumed to be 0. The bit values in each array element, whether fixed or variable width, correspond to significance order in `avalbits` and `bvalbits`. That is, the lsb of `rawvals[0]` and `rawvals[ngroups]` indicates the A and B value of the lsb (0th) bit of the first array element, respectively, and the lsb of `rawvals[1]` and `rawvals[ngroups+1]` indicates the A and B value of bit 8 of the first array element (if it is of width 9 bits or greater), and so on.

The `index_p` argument is an array containing the indices of the starting element of the array object to be retrieved. The indices are ordered in this array according to left-to-right order they would appear in an expression in HDL text. The size of the `index_p` index array shall be equal to the number of unpacked dimensions of `obj`, the array object.

The array element values will be set consecutively in order of the fastest varying index (rightmost unpacked range of the array declaration), followed by more slowly varying indices accordingly until the number of elements (`num`) has been loaded. Index values within each range are ordered from leftmost range value to rightmost. For example, elements of an array `a[2:0][3:5]` with `index_p[0] = 1` and `index_p[1] = 4` would be set in the order `a[1][4]`, `a[1][5]`, `a[0][3]`, `a[0][4]`, `a[0][5]`, respectively.

The `flags` field allows the following values to be set to control **vpi_put_value_array()** behavior:

- vpiPropagateOff** This flag inhibits notification of the fanouts of the array that one or more values have changed. This reduces the performance impact of updating large numbers of array elements. If this is used during active simulation, it may require that at least one subsequent update event occurs for the array in order to achieve correct simulation results.
- vpiOneValue** This flag set causes the function to apply only a single element value to the entire array section specified. Data for only one element need be provided in the `s_vpi_arrayvalue` structure.

The **vpi_put_value_array()** function does not allow the delay and event scheduling modes available in the **vpi_put_value()** function (38.34). Its behavior is consistent with the **vpiNoDelay** mode specified there. Flags other than **vpiPropagateOff**, **vpiOneValue**, or **vpiNoDelay** (the default) specified shall be an error.

When the **vpi_put_value_array()** function is called for an object of type **vpiArrayNet**, the values supplied override the resolved values of the array net elements specified. These values shall remain in effect for each

38.36 vpi_register_cb()

vpi_register_cb()			
Synopsis:	Register simulation-related callbacks.		
Syntax:	vpi_register_cb(cb_data_p)		
	Type	Description	
Returns:	vpiHandle	Handle to the callback object.	
	Type	Name	Description
Arguments:	p_cb_data	cb_data_p	Pointer to a structure with data about when callbacks should occur and the data to be passed.
Related routines:	Use vpi_register_systf() to register callbacks for user-defined system tasks and system functions. Use vpi_remove_cb() to remove callbacks registered with vpi_register_cb().		

The VPI routine **vpi_register_cb()** is used for registration of simulation-related callbacks to a user-provided application for a variety of reasons during a simulation. The reasons for which a callback can occur are divided into the following three categories:

- Simulation event
- Simulation time
- Simulation action or feature

How callbacks are registered for each of these categories is explained in this subclause.

The *cb_data_p* argument shall point to a *s_cb_data* structure, which is defined in *vpi_user.h* and given in [Figure 38-17](#).

```
typedef struct t_cb_data
{
    PLI_INT32    reason;           /* callback reason */
    PLI_INT32    (*cb_rtn)(struct t_cb_data *); /* call routine */
    vpiHandle    obj;            /* trigger object */
    p_vpi_time   time;           /* callback time */
    p_vpi_value  value;          /* trigger object value */
    PLI_INT32    index;          /* index of the memory word or var select
                                that changed */

    PLI_BYTE8    *user_data;
} s_cb_data, *p_cb_data;
```

Figure 38-17—s_cb_data structure definition

For all callbacks, the *reason* field of the *s_cb_data* structure shall be set to a predefined constant, e.g., **cbValueChange**, **cbAtStartOfSimTime**, **cbEndOfCompile**. The reason constant shall determine when the application shall be called back. See the *vpi_user.h* file listing in [Annex K](#) and *sv_vpi_user.h* file in [Annex M](#) for a list of all callback reason constants.

The *cb_rtn* field of the *s_cb_data* structure shall be set to the application routine, which shall be invoked when the simulator executes the callback. The uses of the remaining fields are detailed in [38.36.1](#) through [38.36.3](#).

The callback routine shall be passed a pointer to an `s_cb_data` structure. This structure and all structures to which it points belong to the simulator. If the application needs any of these data, it must copy the data prior to returning from the callback routine.

38.36.1 Simulation event callbacks

The `vpi_register_cb()` callback mechanism can be registered for callbacks to occur for simulation events, such as value changes on certain objects, lifetime of dynamic data, and execution of a behavioral statement, function call, or thread. When the `cb_data_p->reason` field is set to one of the following, the callback shall occur as described below:

cbValueChange	After value change on some variables, any expression, or terminal or after execution of an event statement. Specifically excluded are class objects, dynamic arrays, strings, queues, and associative arrays.
cbStmt	Before execution of a behavioral statement.
cbForce/cbRelease	After a force or release has occurred.
cbAssign/cbDeassign	After a procedural assign or deassign statement has been executed.
cbDisable	After a named block or task containing a system task or system function has been disabled.
cbCreateObj	After the class constructor call has completed and the internal state of a class object has been initialized, or for shallow copy, after the copy operation has completed.
cbReclaimObj	Before the class object has been reclaimed by the automatic memory management, when it has been marked as no longer being used. When control is returned from this callback, any handles to this class object, its properties or their subelements, and any associated callbacks should be considered invalid.
cbSizeChange	After a dynamic array, associative array, queue, or string has been resized.
cbStartOfFrame	Triggers when a frame is activated, i.e., when the associated task or function begins execution. The frame's automatic variables have been created and initialized.
cbEndOfFrame	Triggers when a frame's associated task or function completes execution and indicates that the frame is about to end. When control is returned from this callback, any handles to this frame, its automatic variables, or their subelements should be considered invalid.
cbStartOfThread	Triggers whenever any thread is created.
cbEndOfThread	Triggers when a particular thread gets deleted. All frames activated with this thread will have already ended. Any outdated references made by the thread are subject to deletion. When control is returned from this callback, any handles to this thread, its out of scope references, or their subelements should be considered invalid.
cbEnterThread	Triggers whenever a particular thread resumes execution.
cbEndOfObject	Triggers when a particular transient object is going to be deleted as a result of a simulation event. Depending on the nature of the object, the semantics are equivalent to cbReclaimObj , cbEndOfFrame , or cbEndOfThread , as appropriate. In particular, when control is returned from this callback, any handles to this object or its subelements should be considered invalid.

The following fields shall need to be initialized before passing the `s_cb_data` structure to `vpi_register_cb()`:

<code>cb_data_p->obj</code>	This field shall be assigned a handle to an appropriate object, including class typespec, frame, thread, variable including a class property, expression, terminal,
--------------------------------	---

or statement for which the callback shall occur. For **cbCreateObj**, this field shall be assigned a handle to a class typespec object. For a **cbReclaimObj**, this field shall be assigned either a handle to a class typespec or a class obj. With a class typespec, any class object of that type shall generate a callback. For force and release callbacks, if this is set to `NULL`, every force and release shall generate a callback.

cb_data_p->time->type

This field shall be set to either **vpiScaledRealTime** or **vpiSimTime**, depending on what time information the application requires during the callback. If simulation time information is not needed during the callback, this field can be set to **vpiSuppressTime**. For **cbReclaimObj** and **cbEndOfObject**, time information is not passed to the callback routine; therefore, this field shall be ignored.

cb_data_p->value->format

This field shall be set to one of the value formats indicated in [Table 38-5](#). If value information is not needed during the callback, this field can be set to **vpiSuppressVal**. For **cbStmt** callbacks, value information is not passed to the callback routine; therefore, this field shall be ignored.

Table 38-5—Value format field of *cb_data_p->value->format*

Format	Registers a callback to return
vpiBinStrVal	String of binary character(s) [1, 0, x, z]
vpiOctStrVal	String of octal character(s) [0-7, x, X, z, Z]
vpiDecStrVal	String of decimal character(s) [0-9]
vpiHexStrVal	String of hex character(s) [0-f, x, X, z, Z]
vpiScalarVal	vpi1, vpi0, vpiX, vpiZ, vpiH, vpiL
vpiIntVal	Integer value of the handle
vpiRealVal	Value of the handle as a double
vpiStringVal	An ASCII string
vpiTimeVal	Integer value of the handle using two integers
vpiVectorVal	<i>aval/bval</i> representation of the value of the object
vpiStrengthVal	Value plus strength information of a scalar object only
vpiObjTypeVal	Return a value in the closest format of the object

When a simulation event callback occurs, the application shall be passed a single argument, which is a pointer to an `s_cb_data` structure (this is not a pointer to the same structure that was passed to **vpi_register_cb()**). The *time* and *value* information shall be set as directed by the *time type* and *value format* fields in the call to **vpi_register_cb()**. The *user_data* field shall be equivalent to the *user_data* field passed to **vpi_register_cb()**. The application can use the information in the passed structure and information retrieved from other VPI routines to perform the desired callback processing.

cbValueChange callbacks can be placed onto event statements. When the event statement is executed, the callback routine will be called. Because event statements do not have a value, when the callback routine is called, the value field of the `s_cb_data` structure will be `NULL`.

For a **cbValueChange** callback, if the *obj* has the **vpiArrayMember** property set to `TRUE`, the *value* in the `s_cb_data` structure shall be the value of the array member that changed value. The *index* field shall contain the index of the rightmost range of the array declaration. Use **vpi_iterate(vpiIndex,obj)** to find all the indices.

The **cbValueChange** callback may be placed on a class var and will be called when its value changes, which indicates that it is referring to a new dynamic object (including a newly constructed one) or no object. Its value is opaque and cannot be obtained and the value field of `s_cb_data` structure will be `NULL`. Its **vpiObjId** property uniquely identifies what dynamic object, if any, a class var refers to.

If a **cbValueChange** callback is registered and the format is set to **vpiStrengthVal**, then the callback shall occur whenever the object changes strength, including changes that do not result in a value change.

For a **cbReclaimObj** callback, there is no relationship to simulation time defined when automatic memory management may occur. The time field of the `s_cb_data` structure will be `NULL`. The object field will contain a valid handle to the class obj that is about to be reclaimed. The purpose of this callback is to allow applications to cleanup their data structures. All VPI properties of the class obj are accessible. Using this handle as a reference for purposes of navigation or registering callbacks is undefined.

For **cbForce**, **cbRelease**, **cbAssign**, and **cbDeassign** callbacks, the object returned in the *obj* field shall be a handle to the force, release, assign, or deassign statement. The *value* field shall contain the resultant value of the left-hand expression. In the case of a release, the *value* field shall contain the value after the release has occurred.

For a **cbDisable** callback, *obj* shall be a handle to a system task call, system function call, named begin, named fork, task, or function.

It is illegal to attempt to place a callback for reason **cbForce**, **cbRelease**, or **cbDisable** on a variable bit-select.

The following example shows an implementation of a simple monitor functionality for scalar nets, using a simulation event callback:

```
setup_monitor(net)
vpiHandle net;
{
    static s_vpi_time time_s = {vpiSimTime};
    static s_vpi_value value_s = {vpiBinStrVal};
    static s_cb_data cb_data_s =
        {cbValueChange, my_monitor, NULL, &time_s, &value_s};
    PLI_BYTE8 *net_name = vpi_get_str(vpiFullName, net);
    cb_data_s.obj = net;
    cb_data_s.user_data = malloc(strlen(net_name)+1);
    strcpy(cb_data_s.user_data, net_name);
    vpi_register_cb(&cb_data_s);
}

my_monitor(cb_data_p)
p_cb_data cb_data_p; {
    vpi_printf("%d %d: %s = %s\n",
        cb_data_p->time->high, cb_data_p->time->low,
        cb_data_p->user_data,
        cb_data_p->value->value.str);
}
```

38.36.1.1 Callbacks on individual statements

When **cbStmt** is used in the reason field of the `s_cb_data` structure, the other fields in the structure will be defined as follows:

- `cb_data_p->cb_rtn` The function to call before the given statement executes.
- `cb_data_p->obj` A handle to the statement on which to place the callback (the allowable objects are listed in [Table 38-6](#)).
- `cb_data_p->time` A pointer to an `s_vpi_time` structure, in which only the type is used, to indicate the type of time that will be returned when the callback is made. This type can be **vpiScaledRealTime**, **vpiSimTime**, or **vpiSuppressTime** if no time information is needed by the callback routine.
- `cb_data_p->value` Not used.
- `cb_data_p->index` Not used.
- `cb_data_p->user_data` Data to be passed to the callback function.

Just before the indicated statement executes, the indicated function will be called with a pointer to a new `s_cb_data` structure, which will contain the following information:

- `cb_data_p->reason` **cbStmt**.
- `cb_data_p->cb_rtn` The same value as passed to **vpi_register_cb()**.
- `cb_data_p->obj` A handle to the statement which is about to execute.
- `cb_data_p->time` A pointer to an `s_vpi_time` structure, which will contain the current simulation time, of the type (**vpiScaledRealTime** or **vpiSimTime**) indicated in the call to **vpi_register_cb()**. If the value in the call to **vpi_register_cb()** was **vpiSuppressTime**, then the time pointer in the `s_cb_data` structure will be set to **NULL**.
- `cb_data_p->value` Always **NULL**.
- `cb_data_p->index` Always set to 0.
- `cb_data_p->user_data` The value passed in as `user_data` in the call to **vpi_register_cb()**.

Multiple calls to **vpi_register_cb()** with the same data shall result in multiple callbacks.

Placing callbacks on statements that reside in protected portions of the code shall not be allowed and shall cause **vpi_register_cb()** to return a **NULL** with an appropriate error message printed.

38.36.1.2 Behavior by statement type

Every possible object within the *stmt* class qualifies for having a **cbStmt** callback placed on it. Each possible object is listed in [Table 38-6](#), for further clarification.

Table 38-6—cbStmt callbacks

Object	Description
vpiBegin vpiNamedBegin vpiFork vpiNamedFork	One callback will occur prior to any of the statements within the block executing. The handle returned in the <code>obj</code> field will be the handle to the block object.
vpiIf vpiIfElse	The callback will occur before the condition expression in the if statement is evaluated.
vpiWhile	A callback will occur prior to the evaluation of the condition expression on every iteration of the loop.

Table 38-6—cbStmt callbacks (continued)

Object	Description
vpiRepeat	A callback will occur when the repeat statement is first encountered and on every subsequent iteration of the repeat loop.
vpiFor	A callback will occur prior to any of the control expressions being evaluated. Then on every iteration of the loop, a callback will occur prior to the evaluation of the incremental statement.
vpiForever	A callback will occur when the forever statement is first encountered and on every subsequent iteration of the forever loop.
vpiWait vpiCase vpiAssignment vpiAssignStmt vpiDeassign vpiDisable vpiForce vpiRelease vpiEventStmt	The callback will occur before the statement executes.
vpiDelayControl	The callback will occur when the delay control is encountered, before the delay occurs.
vpiEventControl	The callback will occur when the event control is encountered, before the event has occurred.
vpiTaskCall vpiSysTaskCall	The callback will occur before the given task is executed.

38.36.1.3 Registering callbacks on module-wide basis

vpi_register_cb() allows a handle to a module instance in the *obj* field of the *s_cb_data* structure. When this is done, the effect will be to place a callback on every statement that can have a callback placed on it.

When using **vpi_register_cb()** on a module object, the call will return a handle to a single callback object that can be passed to **vpi_remove_cb()** to remove the callback on every statement in the module instance.

Statements that reside in protected portions of the code shall not have callbacks placed on them.

38.36.2 Simulation time callbacks

The **vpi_register_cb()** can register callbacks to occur for simulation time reasons, including callbacks at the beginning or end of the execution of a particular time queue. The following time-related callback reasons are defined:

- cbAtStartOfSimTime** Callback shall occur before execution of events in a specified time queue. A callback can be set for any time, even if no event is present.
- cbNBASynch** Callback shall occur immediately before the nonblocking assignment events are processed.
- cbReadWriteSynch** Callback shall occur after execution of events for a specified time. This time may be before or after nonblocking assignment events have been processed.
- cbAtEndOfSimTime** Callback shall occur after execution of nonblocking events, but before entering the read-only phase of the time slice.
- cbReadOnlySynch** Callback shall occur the same as for **cbReadWriteSynch**, except that writing values or scheduling events before the next scheduled event is not allowed.

cbNextSimTime	Callback shall occur before execution of events in the next event queue.
cbAfterDelay	Callback shall occur after a specified amount of time, before execution of events in a specified time queue. A callback can be set for any time, even if no event is present.

For reason **cbNextSimTime**, the time field in the time structure is ignored. The following fields shall need to be set before passing the `s_cb_data` structure to **vpi_register_cb()**:

`cb_data_p->time->type`

This field shall be set to either **vpiScaledRealTime** or **vpiSimTime**, depending on what time information the application requires during the callback. **vpiSuppressTime** (or `NULL` for the `cb_data_p->time` field) will result in an error.

`cb_data_p->[time->low,time->high,time->real]`

These fields shall contain the requested time of the callback or the delay before the callback.

The following situations will generate an error, and no callback will be created:

- Attempting to place a **cbAtStartOfSimTime** callback with a delay of zero when simulation has progressed into a time slice and the application is not currently within a **cbAtStartOfSimTime** callback.
- Attempting to place a **cbReadWriteSynch** callback with a delay of zero at read-only synch time.

Placing a callback for **cbAtStartOfSimTime** and a delay of zero during a callback for reason **cbAtStartOfSimTime** will result in another **cbAtStartOfSimTime** callback occurring during the same time slice.

The *value* fields are ignored for all reasons with simulation time callbacks.

When the `cb_data_p->time->type` is set to **vpiScaledRealTime**, the `cb_data_p->obj` field shall be used as the object for determining the time scaling.

When a simulation time callback occurs, the application callback routine shall be passed a single argument, which is a pointer to an `s_cb_data` structure [this is not a pointer to the same structure that was passed to **vpi_register_cb()**]. The *time* structure shall contain the current simulation time. The *user_data* field shall be equivalent to the *user_data* field passed to **vpi_register_cb()**.

The callback application can use the information in the passed structure and information retrieved from other interface routines to perform the desired callback processing.

38.36.3 Simulator action or feature callbacks

The **vpi_register_cb()** routine can register callbacks to occur for simulator action reasons or simulator feature reasons. *Simulator action reasons* are callbacks such as the end of compilation or end of simulation. *Simulator feature reasons* are tool-specific features, such as restarting from a saved simulation state or entering an interactive mode. Actions are differentiated from features in that actions shall occur in all VPI-compliant tools, whereas features might not exist in all VPI-compliant tools.

The following action-related callbacks shall be defined:

cbEndOfCompile	End of simulation data structure compilation or build
cbStartOfSimulation	Start of simulation (beginning of time 0 simulation cycle)
cbEndOfSimulation	End of simulation (simulation ended because no more events remain in the event queue or a <code>\$finish</code> system task executed)

cbError	Simulation run-time error occurred
cbPLIError	Simulation run-time error occurred in a PLI function call
cbTchkViolation	Timing check error occurred
cbSignal	A signal occurred

Examples of possible feature-related callbacks are as follows:

cbStartOfSave	Simulation save state command invoked
cbEndOfSave	Simulation save state command completed
cbStartOfRestart	Simulation restart from saved state command invoked
cbEndOfRestart	Simulation restart command completed
cbEnterInteractive	Simulation entering interactive debug mode (e.g., \$stop system task executed)
cbExitInteractive	Simulation exiting interactive mode
cbInteractiveScopeChange	Simulation command to change interactive scope executed
cbUnresolvedSystf	Unknown user-defined system task or system function encountered

The only fields in the `s_cb_data` structure that shall need to be set up for simulation action or feature callbacks are the `reason`, `cb_rtn`, and `user_data` (if desired) fields.

vpi_register_cb() can be used to set up a signal handler. To do this, set the `reason` field to `cbSignal`, and set the `index` field to one of the legal signals specified by the operating system. When this signal occurs, the simulator will trap the signal, proceed to a safe point (if possible), and then call the callback routine.

When a simulation action or feature callback occurs, the application routine shall be passed a pointer to an `s_cb_data` structure. The `reason` field shall contain the reason for the callback. For **cbTchkViolation** callbacks, the `obj` field shall be a handle to the timing check. For **cbInteractiveScopeChange**, `obj` shall be a handle to the new scope. For **cbUnresolvedSystf**, `user_data` shall point to the name of the unresolved task or system function. On a **cbError** callback, the routine **vpi_chk_error()** can be called to retrieve error information.

When an implementation restarts, the only VPI callbacks that shall exist are those for **cbStartOfRestart** and **cbEndOfRestart**.

NOTE—When an application registers for these two callbacks, the `user_data` field should not be a pointer into memory. The reason for this is that the executable used to restart an implementation may not be the exact same one used to save the implementation state. A typical use of the `user_data` field for these two callbacks would be to store the identifier returned from a call to **vpi_put_data()**.

With the exception of **cbStartOfRestart** and **cbEndOfRestart** callbacks, when a restart occurs all registered callbacks shall be removed.

The following example shows a callback application that reports CPU usage at the end of a simulation. If the application routine `setup_report_cpu()` is placed in the `vlog_startup_routines` list, it shall be called just after the simulator is invoked.

```
static PLI_INT32 initial_cputime_g;

void report_cpu()
{
    PLI_INT32 total = get_current_cputime() - initial_cputime_g;
    vpi_printf("Simulation complete. CPU time used: %d\n", total);
}

void setup_report_cpu()
```

```
{
    static s_cb_data cb_data_s = {cbEndOfSimulation, report_cpu};
    initial_cputime_g = get_current_cputime();
    vpi_register_cb(&cb_data_s);
}
```

38.37 vpi_register_systf()

vpi_register_systf()			
Synopsis:	Register user-defined system task or system function callbacks.		
Syntax:	vpi_register_systf(systf_data_p)		
	Type	Description	
Returns:	vpiHandle	Handle to the callback object.	
	Type	Name	Description
Arguments:	p_vpi_systf_data	systf_data_p	Pointer to a structure with data about when callbacks should occur and the data to be passed.
Related routines:	Use vpi_register_cb() to register callbacks for simulation events.		

The VPI routine **vpi_register_systf()** shall register callbacks for user-defined system tasks or functions. Callbacks can be registered to occur when a user-defined system task or system function is encountered during compilation or execution of SystemVerilog source code.

The *systf_data_p* argument shall point to a *s_vpi_systf_data* structure, which is defined in *vpi_user.h* and listed in [Figure 38-18](#).

```
typedef struct t_vpi_systf_data
{
    PLI_INT32 type;          /* vpiSysTask, vpiSysFunc */
    PLI_INT32 sysfunctype; /* vpiSysTask, vpi[Int,Real,Time,Sized,
                           SizedSigned]Func */
    PLI_BYTE8 *tfname;     /* first character must be '$' */
    PLI_INT32 (*calltf)(PLI_BYTE8 *);
    PLI_INT32 (*completf)(PLI_BYTE8 *);
    PLI_INT32 (*sizedtf)(PLI_BYTE8 *); /* for sized function
                                         callbacks only */
    PLI_BYTE8 *user_data;
} s_vpi_systf_data, *p_vpi_systf_data;
```

Figure 38-18—s_vpi_systf_data structure definition

38.37.1 System task and system function callbacks

User-defined SystemVerilog system tasks and system functions that use VPI routines can be registered with **vpi_register_systf()**. The following system task and system function callbacks are defined:

The *type* field of the *s_vpi_systf_data* structure shall register the application to be a system task or a system function. The *type* field value shall be an integer constant of **vpiSysTask** or **vpiSysFunc**.

The *sysfunctype* field of the *s_vpi_systf_data* structure shall define the type of value that a system function shall return. The *sysfunctype* field shall be an integer constant of **vpiIntFunc**, **vpiRealFunc**, **vpiTimeFunc**, **vpiSizedFunc**, or **vpiSizedSignedFunc**. This field shall only be used when the *type* field is set to **vpiSysFunc**.

tfname is a character string containing the name of the system task or system function as it will be used in SystemVerilog source code. The name shall begin with a dollar sign (\$) and shall be followed by one or more ASCII characters that are legal in SystemVerilog simple identifiers. These are the characters A through Z, a through z, 0 through 9, underscore (_), and the dollar sign (\$). The maximum name length shall be the same as for SystemVerilog identifiers.

The *compiletf*, *calltf*, and *sizetf* fields of the *s_vpi_systf_data* structure shall be pointers to the user-provided applications that are to be invoked by the system task or system function callback mechanism. One or more of the *compiletf*, *calltf*, and *sizetf* fields can be set to NULL if they are not needed. Callbacks to the applications pointed to by the *compiletf* and *sizetf* fields shall occur when the simulation data structure is compiled or built (or for the first invocation if the system task or system function is invoked from an interactive mode). Callbacks to the application pointed to by the *calltf* routine shall occur each time the system task or system function is invoked during simulation execution.

The *sizetf* application shall only be called if the PLI application type is **vpiSysFunc** and the *sysfunctype* is **vpiSizedFunc** or **vpiSizedSignedFunc**. If no *sizetf* is provided, a user-defined system function of type **vpiSizedFunc** or **vpiSizedSignedFunc** shall return 32 bits.

The contents of the *user_data* field of the *s_vpi_systf_data* structure shall be the only argument passed to the *compiletf*, *sizetf*, and *calltf* routines when they are called. This argument shall be of the type "PLI_BYTE8 *".

The following two examples illustrate allocating and filling in the *s_vpi_systf_data* structure and calling the **vpi_register_systf()** function. These examples show two different C programming methods of filling in the structure fields. A third method is shown in [38.37.3](#).

```

/*
 * VPI registration data for a $list_nets system task
 */
void listnets_register()
{
    s_vpi_systf_data tf_data;
    tf_data.type      = vpiSysTask;
    tf_data.tfname    = "$list_nets";
    tf_data.calltf    = ListCall;
    tf_data.compiletf = ListCheck;
    vpi_register_systf(&tf_data);
}

/*
 * VPI registration data for a $my_random system function
 */
void my_random_init()
{
    s_vpi_systf_data func_data;
    p_vpi_systf_data func_data_p = &func_data;
    PLI_BYTE8 *my_workarea;
    my_workarea = malloc(256);
    func_data_p->type      = vpiSysFunc;
    func_data_p->sysfunctype = vpiSizedFunc;
    func_data_p->tfname    = "$my_random";
}

```

```

func_data_p->calltf      = my_random;
func_data_p->compiletf  = my_random_compiletf;
func_data_p->sizetf     = my_random_sizetf;
func_data_p->user_data  = my_workarea;
vpi_register_systf(func_data_p);
}

```

38.37.2 Initializing VPI system task or system function callbacks

A means of initializing system task and system function callbacks and performing any other desired task just after the simulator is invoked shall be provided by placing routines in a `NULL`-terminated static array, `vlog_startup_routines`. A C function using the array definition shall be provided as follows:

```
void (*vlog_startup_routines[]) ();
```

This C function shall be provided with a VPI-compliant tool. Entries in the array shall be added by the user. The location of `vlog_startup_routines` and the procedure for linking `vlog_startup_routines` with a tool shall be defined by the tool vendor.

NOTE—Callbacks can also be registered or removed at any time during an application routine, not just at startup time.

This array of C functions shall be for registering system tasks and system functions. User-defined system tasks and system functions that appear in a compiled description shall generally be registered by a routine in this array.

The following example uses `vlog_startup_routines` to register the system task and system function that were defined in the examples in [38.37.1](#).

A tool vendor shall supply a file that contains the `vlog_startup_routines` array. The names of the PLI application register functions shall be added to this vendor-supplied file.

```

extern void listnets_register();
extern void my_random_init();
void (*vlog_startup_routines[]) () =
{
    listnets_register,
    my_random_init,
    0
}

```

38.37.3 Registering multiple system tasks and system functions

Multiple system tasks and system functions can be registered at least two different ways:

- Allocate and define separate `s_vpi_systf_data` structures for each system task and system function, and call `vpi_register_systf()` once for each structure. This is the method that was used by the examples in [38.37.1](#) and [38.37.2](#).
- Allocate a static array of `s_vpi_systf_data` structures, and call `vpi_register_systf()` once for each structure in the array. If the final element in the array is set to zero, then the calls to `vpi_register_systf()` can be placed in a loop that terminates when it reaches the 0.

The following example uses a static structure to declare three system tasks and system functions and places `vpi_register_systf()` in a loop to register them:

```

/*In a vendor tool file which contains vlog_startup_routines ...*/
extern void register_my_systfs();
extern void my_init();

```

```

void (*vlog_startup_routines[])() =
{
    setup_report_cpu,      /* user routine example in 38.36.3 */
    register_my_systfs,   /* user routine listed below */
    0                      /* must be last entry in list */
}

/* In a user provided file... */
void register_my_systfs()
{
    static s_vpi_systf_data systfTestList[] = {
        {vpiSysTask, 0, "$my_task", my_task_calltf, my_task_comptf,0,0},
        {vpiSysFunc, vpiIntFunc, "$my_int_func", my_int_func_calltf,
            my_int_func_comptf, 0,0},
        {vpiSysFunc, vpiSizedFunc, "$my_sized_func",
            my_sized_func_calltf, my_sized_func_comptf,
            my_sized_func_sizetf,0},
    };

    p_vpi_systf_data systf_data_p = &(systfTestList[0]);

    while (systf_data_p->type)
        vpi_register_systf(systf_data_p++);
}

```

38.38 vpi_release_handle()

vpi_release_handle()			
Synopsis:	Release handle and its associated resources allocated by VPI routines.		
Syntax:	vpi_release_handle(obj)		
	Type	Description	
Returns:	PLI_INT32	1 (true) on success; 0 (false) on failure.	
	Type	Name	Description
Arguments:	vpiHandle	obj	Handle of an object.
Related routines:			

The VPI routine **vpi_release_handle()** shall free memory allocated for VPI handles. The SystemVerilog tool may allocate memory when a handle to an object is obtained, although often all required memory has been allocated when the underlying object was first created or elaborated. One may safely ignore calling **vpi_release_handle()** when a handle is no longer needed, but it is always advisable to do so, provided the handle is valid and will not automatically become invalid in the future. This avoids logical memory leaks. **vpi_release_handle()** shall not be called on an invalid handle.

vpi_release_handle() may be used to free memory created for iterator objects. The iterator object shall automatically be freed when **vpi_scan()** returns NULL because it has either completed an object traversal or encountered an error condition. If neither of these conditions occurs (which can happen if the code breaks out of an iteration loop before it has scanned every object), **vpi_release_handle()** should be called to free any memory allocated for the iterator.

The routine shall return 1 (true) on success and 0 (false) on failure.

38.39 vpi_remove_cb()

vpi_remove_cb()			
Synopsis:	Remove a simulation-related callback registered with <code>vpi_register_cb()</code> .		
Syntax:	<code>vpi_remove_cb(cb_obj)</code>		
	Type	Description	
Returns:	PLI_INT32	1 (true) if successful; 0 (false) on a failure.	
	Type	Name	Description
Arguments:	vpiHandle	cb_obj	Handle to the callback object.
Related routines:	Use <code>vpi_register_cb()</code> to register callbacks for simulation events.		

The VPI routine `vpi_remove_cb()` shall remove callbacks that were registered with `vpi_register_cb()`. The argument to this routine shall be a handle to the callback object. The routine shall return a 1 (true) if successful and a 0 (false) on a failure. After `vpi_remove_cb()` is called with a handle to the callback, the handle is no longer valid.

38.40 vpi_scan()

vpi_scan()			
Synopsis:	Scan the SystemVerilog hierarchy for objects with a one-to-many relationship.		
Syntax:	<code>vpi_scan(itr)</code>		
	Type	Description	
Returns:	vpiHandle	Handle to an object.	
	Type	Name	Description
Arguments:	vpiHandle	itr	Handle to an iterator object returned from <code>vpi_iterate()</code> .
Related routines:	Use <code>vpi_iterate()</code> to obtain an iterator handle. Use <code>vpi_handle()</code> to obtain handles to an object with a one-to-one relationship. Use <code>vpi_handle_multi()</code> to obtain a handle to an object with a many-to-one relationship.		

The VPI routine `vpi_scan()` shall traverse the instantiated SystemVerilog hierarchy and return handles to objects as directed by the iterator `itr`. The iterator handle shall be obtained by calling `vpi_iterate()` for a specific object type. Once `vpi_scan()` returns NULL, the iterator handle is no longer valid and cannot be used again.

The following example application uses `vpi_iterate()` and `vpi_scan()` to display each net (including the size for vectors) declared in the module. The example assumes it shall be passed a valid module handle.

```
void display_nets(mod)
vpiHandle mod;
{
    vpiHandle net;
    vpiHandle itr;
```

```

vpi_printf("Nets declared in module %s\n",
vpi_get_str(vpiFullName, mod));

itr = vpi_iterate(vpiNet, mod);
while (net = vpi_scan(itr))
{
  vpi_printf("\t%s", vpi_get_str(vpiName, net));
  if (vpi_get(vpiVector, net))
  {
    vpi_printf(" of size %d\n", vpi_get(vpiSize, net));
  }
  else vpi_printf("\n");
}
}

```

38.41 vpi_vprintf()

vpi_vprintf()			
Synopsis:	Write to the output channel of the tool that invoked the PLI application and the current tool log file using varargs that are already started.		
Syntax:	vpi_vprintf(format, ap)		
	Type	Description	
Returns:	PLI_INT32	The number of characters written.	
	Type	Name	Description
Arguments:	PLI_BYTE8 *	format	A format string using the C printf() format.
	va_list	ap	An already started varargs list.
Related routines:	Use vpi_printf() to write a finite number of arguments. Use vpi_mcd_printf() to write to an opened file. Use vpi_mcd_vprintf() to write a variable number of arguments to an opened file.		

This routine performs the same function as **vpi_printf()**, except that varargs have already been started.

39. Assertion API

39.1 General

This clause describes the following:

- The SystemVerilog assertion API
- Obtaining assertion handles
- Assertions system callbacks
- Assertion control API functions

39.2 Overview

SystemVerilog provides assertion capabilities to enable the following:

- A user's C code to react to assertion events
- Third-party assertion “waveform” dumping tools to be written
- Third-party assertion coverage tools to be written
- Third-party assertion debug tools to be written

39.3 Static information

This subclause defines how to obtain assertion handles and other static assertion information.

39.3.1 Obtaining assertion handles

SystemVerilog extends the VPI navigation model to encompass assertions, properties, and sequences. It also enhances the instance iterator model with direct access to assertions, properties, and sequences.

The following steps highlight how to obtain the assertion handles for named assertions through direct access:

- a) Iterate all assertions in the design: use a NULL reference handle (**ref**) to **vpi_iterate()**. For example:

```
itr = vpi_iterate(vpiAssertion, NULL);  
while (assertion = vpi_scan(itr)) {  
    /* process assertion */  
}
```

- b) Iterate all assertions in an instance: pass the appropriate instance handle as a reference handle to **vpi_iterate()**. For example:

```
itr = vpi_iterate(vpiAssertion, instanceHandle);  
while (assertion = vpi_scan(itr)) {  
    /* process assertion */  
}
```

- c) Obtain the assertion by name: extend **vpi_handle_by_name()** to also search for assertion names in the appropriate scope(s). For example:

```
vpiHandle = vpi_handle_by_name(assertName, scope)
```

- d) To obtain an assertion of a specific type, e.g., concurrent **cover property** statements, the following approach should be used:

```
vpiHandle assertion;  
itr = vpi_iterate(vpiAssertion, NULL);  
while (assertion = vpi_scan(itr)) {  
    if (vpi_get(vpiType, assertion) == vpiCover) {  
        /* process cover type assertion */  
    }  
}
```

Details:

- As with all VPI handles, assertion handles are handles to a specific instance of a specific assertion.
- Unnamed assertions cannot be found by name.

39.3.2 Obtaining static assertion information

The following information about an assertion is considered to be static:

- Assertion name
- Instance in which the assertion occurs
- Module definition containing the assertion
- Assertion type
 - Sequence instance
 - Assert
 - Assume
 - Cover
 - Property instance
 - Immediate assert
 - Immediate assume
 - Immediate cover
- Assertion source information: the file, line, and column where the assertion is defined
- Assertion **clocking** block/expression

39.4 Dynamic information

This subclause defines how to place assertion system and assertion callbacks.

39.4.1 Placing assertion system callbacks

To place an assertion system callback, use **vpi_register_cb()**, setting the **cb_rtn** element to the function to be invoked and the **reason** element of the **s_cb_data** structure to one of the following values:

- **cbAssertionSysInitialized**. This callback occurs after the system has initialized. No assertion-specific actions can be performed until this callback completes. The assertion system can initialize before **cbStartOfSimulation** does or afterwards.
- **cbAssertionSysOn**. The assertion system has become active and starts processing assertion attempts. This always occurs after **cbAssertionSysInitialized**. By default, the assertion system is “started” on simulation startup, but the user can delay this by using assertion system control actions.
- **cbAssertionSysOff**. The assertion system has been temporarily suspended. While stopped, no new assertion attempts are processed and no new assertion-related callbacks occur. Assertions already

executing are not affected. The assertion system can be stopped and resumed an arbitrary number of times during a single simulation run.

- **cbAssertionSysKill**. The assertion system has been temporarily suspended. While suspended, no assertion attempts are processed, and no assertion-related callbacks occur. The assertion system can be suspended and resumed an arbitrary number of times during a single simulation run.
- **cbAssertionSysEnd**. This callback occurs when all assertions have completed and no new attempts shall start. Once this callback occurs, no more assertion-related callbacks shall occur, and assertion-related actions shall have no further effect. This typically occurs after the end of simulation.
- **cbAssertionSysReset**. This callback occurs when the assertion system is reset, e.g., due to a system control action.
- **cbAssertionSysEnablePassAction**. The pass action is enabled for vacuous and nonvacuous success for the assertion (e.g., as a result of a system control action).
- **cbAssertionSysEnableFailAction**. The fail action is enabled for vacuous and nonvacuous success for the assertion (e.g., as a result of a system control action).
- **cbAssertionSysDisablePassAction**. The pass action is disabled for vacuous and nonvacuous success for the assertion (e.g., as a result of a system control action).
- **cbAssertionSysDisableFailAction**. The fail action is disabled for vacuous and nonvacuous success for the assertion (e.g., as a result of a system control action).
- **cbAssertionSysEnableNonvacuousAction**. The pass action is enabled for nonvacuous success of the assertion (e.g., as a result of a system control action).
- **cbAssertionSysDisableVacuousAction**. The pass action is disabled for vacuous success of the assertion (e.g., as a result of a system control action).

The callback routine invoked follows the normal VPI callback prototype and is passed an `s_cb_data` containing the callback reason and any user data provided to the `vpi_register_cb()` call.

39.4.2 Placing assertions callbacks

To place an assertion callback, use `vpi_register_assertion_cb()`. The prototype is as follows:

```

/* typedef for vpi_register_assertion_cb callback function */
typedef PLI_INT32 (vpi_assertion_callback_func) (
    PLI_INT32 reason,          /* callback reason */
    p_vpi_time cb_time,      /* callback time */
    vpiHandle assertion,     /* handle to assertion */
    p_vpi_attempt_info info, /* attempt related information */
    PLI_BYTE8 *user_data     /* user data entered upon registration */
);

vpiHandle vpi_register_assertion_cb(
    vpiHandle assertion,     /* handle to assertion */
    PLI_INT32 reason,        /* reason for which callbacks needed */
    vpi_assertion_callback_func *cb_rtn,
    PLI_BYTE8 *user_data    /* user data to be supplied to cb */
);

typedef struct t_vpi_assertion_step_info {
    PLI_INT32 matched_expression_count;
    vpiHandle *matched_exprs; /* array of expressions */
    PLI_INT32 stateFrom, stateTo; /* identify transition */
} s_vpi_assertion_step_info, *p_vpi_assertion_step_info;

typedef struct t_vpi_attempt_info {
    union {

```

```
        vpiHandle failExpr;  
        p_vpi_assertion_step_info step;  
    } detail;  
    s_vpi_time attemptStartTime; /* Time attempt triggered */  
} s_vpi_attempt_info, *p_vpi_attempt_info;
```

where *reason* is any of the following.

- **cbAssertionStart**. An assertion attempt has started. For most assertions, one attempt starts each and every clock tick. For property and sequence instances the start is the start of evaluation of the property or sequence instance. A property or sequence instance that is not instantiated in a verification statement will never start.
- **cbAssertionSuccess**. An assertion attempt or property instance reaches a success state. For sequence instances, success is a match.
- **cbAssertionVacuousSuccess**. An assertion attempt reaches a vacuous success state.
- **cbAssertionDisabledEvaluation**. An assertion attempt reaches the disabled state (e.g. as a result of **disable iff** condition becoming true or if an attempt starts when the **disable iff** is true).
- **cbAssertionFailure**. An assertion attempt or a property fails to reach a success state or a sequence instance fails to match.
- **cbAssertionStepSuccess**. Progress one step along an attempt. A step is defined as progress along the flattened assertion (e.g. rewriting algorithm defined in [F.5.1](#)). By default, step callbacks are not enabled on any assertions; they are enabled on a per-assertion/per-attempt basis (see [39.5.2](#)), rather than on a per-assertion basis.
- **cbAssertionStepFailure**. Fail to progress by one step along an attempt. A step is defined as progress along the flattened assertion (e.g. rewriting algorithm defined in [F.5.1](#)). By default, step callbacks are not enabled on any assertions; they are enabled on a per-assertion/per-attempt basis (see [39.5.2](#)), rather than on a per-assertion basis.
- **cbAssertionDisable**. The assertion is disabled (e.g., as a result of a control action, see [39.5.2](#)).
- **cbAssertionEnable**. The assertion is enabled (e.g., as a result of a control action, see [39.5.2](#)).
- **cbAssertionReset**. The assertion is reset (e.g., as a result of a control action, see [39.5.2](#)).
- **cbAssertionKill**. An attempt is killed (e.g., as a result of a control action, see [39.5.2](#)).
- **cbAssertionDisablePassAction**. The pass action is disabled for vacuous and nonvacuous success for the assertion (e.g., as a result of control action, see [39.5.2](#)).
- **cbAssertionEnablePassAction**. The pass action is enabled for vacuous and nonvacuous success for the assertion (e.g., as a result of control action, see [39.5.2](#)).
- **cbAssertionDisableFailAction**. The fail action is disabled for the assertion (e.g., as a result of control action, see [39.5.2](#)).
- **cbAssertionDisableVacuousAction**. The pass action is disabled for vacuous success of the assertion (e.g., as a result of control action, see [39.5.2](#)).
- **cbAssertionEnableNonvacuousAction**. The pass action is enabled for nonvacuous success of the assertion (e.g., as a result of control action, see [39.5.2](#)).
- **cbAssertionEnableFailAction**. The fail action is enabled for the assertion (e.g., as a result of control action, see [39.5.2](#)).

Each of these callbacks may be registered on any concurrent or immediate assertion. The **cbAssertionStart**, **cbAssertionSuccess**, and **cbAssertionFailure** callbacks may also be registered on a sequence instance or a property instance.

These callbacks are specific to a given assertion; placing such a callback on one assertion does not cause the callback to trigger on an event occurring on a different assertion. If the callback is successfully placed, a

handle to the callback is returned. This handle can be used to remove the callback via `vpi_remove_cb()`. If there were errors on placing the callback, a `NULL` handle is returned.

Once the callback is placed, the user-supplied function shall be called each time the specified event occurs on the given assertion. The callback shall continue to be called whenever the event occurs until the callback is removed.

The callback function shall be supplied the following arguments:

- The reason for the callback
- A pointer to the time of the callback
- The handle for the assertion
- A pointer to an attempt information structure
- A reference to the user data supplied when the callback was registered

The `t_vpi_attempt_info` attempt information structure contains details relevant to the specific event that occurred.

- On disable, enable, reset, kill, pass action, fail action, vacuous action, and nonvacuous action callbacks, the returned `p_vpi_attempt_info` info pointer is `NULL`, and no attempt information is available.
- On start and success callbacks, only the `attemptStartTime` field is valid.
- On a `cbAssertionFailure` callback, the `attemptStartTime` and `detail.failExpr` fields are valid.
- On a step callback, the `attemptStartTime` and `detail.step` fields are valid.

On a step callback, the `detail` describes the set of expressions matched in satisfying a step along the assertion, along with the corresponding source references. In addition, the `step` also identifies the source and destination “states” needed to uniquely identify the path being taken through the assertion. *State ids* are just integers, with 0 identifying the origin state, 1 identifying an accepting state, and any other number representing some intermediate point in the assertion. It is possible for the number of expressions in a step to be 0, which represents an unconditional transition. In the case of a failing transition, the information provided is just as that for a successful one, but the last expression in the array represents the expression where the transition failed.

Details:

- a) In a failing transition, there shall always be at least one element in the expression array.
- b) Placing a step callback results in the same callback function being invoked for both success and failure steps.
- c) The content of the `cb_time` field depends on the reason identified by the reason field, as follows:
 - **cbAssertionStart**: `cb_time` is the time when the assertion attempt has been started.
 - **cbAssertionSuccess, cbAssertionFailure**: `cb_time` is the time when the assertion succeeded nonvacuously or failed.
 - **cbAssertionVacuousSuccess**: `cb_time` is the time when the assertion succeeded vacuously.
 - **cbAssertionDisabledEvaluation**: `cb_time` is the time when the assertion reached the disabled state.
 - **cbAssertionStepSuccess, cbAssertionStepFailure**: `cb_time` is the time when the assertion attempt step succeeded or failed.
 - **cbAssertionDisable, cbAssertionEnable, cbAssertionReset, cbAssertionKill**: `cb_time` is the time when the assertion attempt was disabled, enabled, reset, or killed.

- d) In contrast to *cb_time*, the content of *attemptStartTime* is always the start time of the actual attempt of an assertion. It can be used as a unique identifier that distinguishes the attempts of any given assertion.
- e) See [39.4.2.1](#) for callbacks for assertions containing global clocking future sampled value functions.

39.4.2.1 Placing callbacks for assertions with global clocking future sampled value functions

Callback execution for assertions referring to global clocking future sampled value functions (see [16.9.4](#)) has the following peculiarities:

- The callback is executed at the nearest tick of the global clock strictly following the callback event
- *cb_time* contains the time of the callback event.

For example:

```
a1: assert property(@(posedge clk) $falling_gclk(a) | => b);
a2: assert property(@(posedge clk) a | => $falling_gclk(b));
```

For both assertions *a1* and *a2* the callback executes at time 12, and not at time 11 when *\$assertkill* directive was issued (see [Figure 39-1](#)). *cb_time* has the time value of 11—the time when the callback event actually happened, and *attemptStartTime* has the time value of 10.

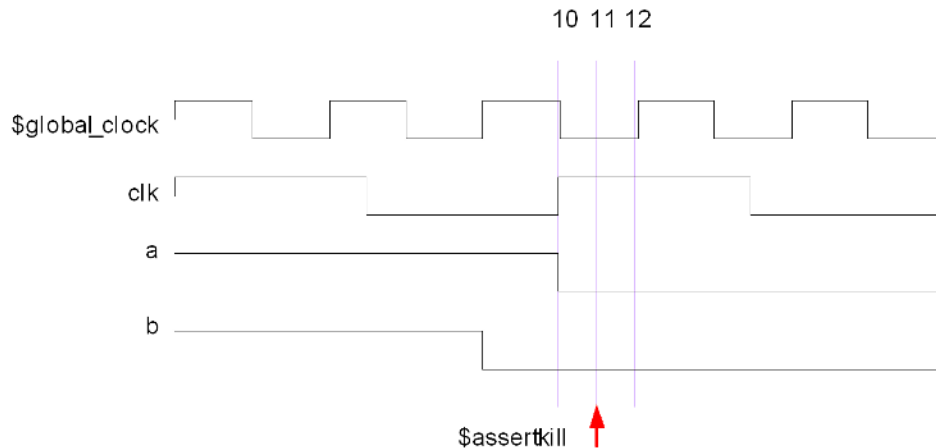

Figure 39-1—Assertions with global clocking future sampled value functions

39.5 Control functions

This subclause defines how to obtain assertion system control and assertion control information.

39.5.1 Assertion system control

To control the assertion system, use **vpi_control()** with one of the following constants and a second handle argument that is either a *vpiHandle* for a scope or a *vpiCollection* of handles for a list of scopes. A NULL handle signifies that the control applies to all assertions regardless of scope.

- Usage example: `vpi_control(vpiAssertionSysReset, handle)`
- **vpiAssertionSysReset** discards all attempts in progress for all assertions and restores the entire assertion system to its initial state. Any pre-existing *vpiAssertionStepSuccess* and

`vpiAssertionStepFailure` callbacks shall be removed; all other assertion callbacks shall remain.

- Usage example: `vpi_control(vpiAssertionSysOff, handle)`
 - **vpiAssertionSysOff** disables any further assertions from being started. Assertions already executing are not affected. This control has no effect on pre-existing assertion callbacks.
 - **vpiAssertionSysKill** discards all attempts in progress and disables any further assertions from being started. This control has no effect on pre-existing assertion callbacks.
- Usage example: `vpi_control(vpiAssertionSysOn, handle)`
 - **vpiAssertionSysOn** restarts the assertion system after it was stopped or suspended (e.g., due to **vpiAssertionSysOff** or **vpiAssertionSysKill**). Once started, attempts shall resume on all assertions. This control has no effect on prior assertion callbacks.
- Usage example: `vpi_control(vpiAssertionSysEnd, handle)`
 - **vpiAssertionSysEnd** discards all attempts in progress and disables any further assertions from starting. All assertion callbacks currently installed shall be removed. Once this control is issued, no further assertion-related actions shall be permitted.
- Usage example: `vpi_control(vpiAssertionSysDisablePassAction, assertionHandle)`
 - **vpiAssertionSysDisablePassAction** disables execution of pass action for vacuous and nonvacuous success of assertions. This has no effect on any existing attempts or if the assertion pass action is already disabled. By default, all assertion pass actions are enabled.
- Usage example: `vpi_control(vpiAssertionSysEnablePassAction, assertionHandle)`
 - **vpiAssertionSysEnablePassAction** enables execution of pass action for vacuous and nonvacuous success of assertions. This has no effect on any existing attempts or if the assertion pass action is already enabled.
- Usage example: `vpi_control(vpiAssertionSysDisableFailAction, assertionHandle)`
 - **vpiAssertionSysDisableFailAction** disables execution of fail action for assertions. This has no effect on any existing attempts or if the assertion fail action is already disabled. By default, all fail actions are enabled.
- Usage example: `vpi_control(vpiAssertionSysEnableFailAction, assertionHandle)`
 - **vpiAssertionSysEnableFailAction** enables execution of fail action for assertions. This has no effect on any existing attempts or if the assertion fail action is already enabled.
- Usage example: `vpi_control(vpiAssertionSysDisableVacuousAction, assertionHandle)`
 - **vpiAssertionSysDisableVacuousAction** disables execution of pass action on vacuous success of assertions. This has no effect on any existing attempts or if the execution of pass action on vacuous success is already disabled. By default, all vacuous actions are enabled.
- Usage example: `vpi_control(vpiAssertionSysEnableNonvacuousAction, assertionHandle)`
 - **vpiAssertionSysEnableNonvacuousAction** enables execution of pass action on nonvacuous success of assertions. This has no effect on any existing attempts or if the pass action for nonvacuous success is already enabled.

39.5.2 Assertion control

To obtain assertion control information for assertion statements (e.g. **assume**, **assert**, **cover**), use **vpi_control()** with one of the operators in this subclause. Only assertion statement handles are valid here, not sequence or property instances.

For the following operators, the second argument shall be a valid assertion handle:

- Usage example: `vpi_control(vpiAssertionReset, assertionHandle)`

- **vpiAssertionReset** discards all current attempts in progress for this assertion and resets this assertion to its initial state.
- Usage example: `vpi_control(vpiAssertionDisable, assertionHandle)`
- **vpiAssertionDisable** disables the starting of any new attempts for this assertion. This has no effect on any existing attempts or if the assertion is already disabled. By default, all assertions are enabled.
- Usage example: `vpi_control(vpiAssertionEnable, assertionHandle)`
- **vpiAssertionEnable** enables starting new attempts for this assertion. This has no effect on any existing attempts or if the assertion is already enabled.
- Usage example: `vpi_control(vpiAssertionDisablePassAction, assertionHandle)`
- **vpiAssertionDisablePassAction** disables execution of pass action for vacuous and nonvacuous success of this assertion. This has no effect on any existing attempts or if the assertion pass action is already disabled. By default, all pass actions are enabled.
- Usage example: `vpi_control(vpiAssertionEnablePassAction, assertionHandle)`
- **vpiAssertionEnablePassAction** enables execution of pass action for vacuous and nonvacuous success of this assertion. This has no effect on any existing attempts or if the assertion pass action is already enabled.
- Usage example: `vpi_control(vpiAssertionDisableFailAction, assertionHandle)`
- **vpiAssertionDisableFailAction** disables execution of fail action for this assertion. This has no effect on any existing attempts or if the assertion fail action is already disabled. By default, all fail actions are enabled.
- Usage example: `vpi_control(vpiAssertionEnableFailAction, assertionHandle)`
- **vpiAssertionEnableFailAction** enables execution of fail action for this assertion. This has no effect on any existing attempts or if the assertion fail action is already enabled.
- Usage example: `vpi_control(vpiAssertionDisableVacuousAction, assertionHandle)`
- **vpiAssertionDisableVacuousAction** disables execution of pass action on vacuous success of this assertion. This has no effect on any existing attempts or if the execution of pass action on vacuous success is already disabled. By default, all vacuous actions are enabled.
- Usage example: `vpi_control(vpiAssertionEnableNonvacuousAction, assertionHandle)`
- **vpiAssertionEnableNonvacuousAction** enables execution of pass action on nonvacuous success of this assertion. This has no effect on any existing attempts or if the pass action is already enabled for nonvacuous success of this assertion.

For the following operators, the second argument shall be a valid assertion handle, and the third argument shall be an attempt start time (as a pointer to a correctly initialized `s_vpi_time` structure):

- Usage example:
`vpi_control(vpiAssertionKill, assertionHandle, attemptStartTime)`
- **vpiAssertionKill** discards the given attempt, but leaves the assertion enabled and does not reset any state used by this assertion (e.g., `past()` sampling).
- Usage example:
`vpi_control(vpiAssertionDisableStep, assertionHandle, attemptStartTime)`
- **vpiAssertionDisableStep** disables step callbacks for this assertion. This has no effect if stepping is not enabled or it is already disabled.

For the following operator, the second argument shall be a valid assertion handle, the third argument shall be an attempt start time (as a pointer to a correctly initialized `s_vpi_time` structure), and the fourth argument shall be a step control constant:

- Usage example:

```
vpi_control(vpiAssertionEnableStep, assertionHandle, attemptStartTime,  
           vpiAssertionClockSteps)
```
- **vpiAssertionEnableStep** enables step callbacks to occur for this assertion attempt. By default, stepping is disabled for all assertions. This call has no effect if stepping is already enabled for this assertion and attempt, other than possibly changing the stepping mode for the attempt if the attempt has not occurred yet. The stepping mode of any particular attempt cannot be modified after the assertion attempt in question has started.
- The fine-grained step control constant **vpiAssertionClockSteps** indicates callbacks on a per-assertion/clock-tick basis. The assertion clock is the event expression supplied as the clocking expression to the assertion declaration. This step callback shall occur at every clocking event, when stepping is enabled, as the assertion “advances” in evaluation.

39.5.3 VPI functions on deferred assertions and procedural concurrent assertions

Deferred assertions (see [16.4](#)) may be in a pending state where the assertion has executed, but been placed in a deferred assertion report queue. Similarly, procedural concurrent assertions (see [16.15.6](#)) may have pending instances in a procedural assertion queue waiting to mature. For any VPI function, if it discards current evaluation attempts in progress, that also means it flushes any pending instances that have not yet matured from these queues. If a VPI function does not interfere with current attempts, that also means it does not affect or flush these queues.

For example, since **vpiAssertionReset** discards all current evaluation attempts in progress for the targeted assertion, if applied to a deferred assertion, it flushes any pending reports for that assertion. However, **vpiAssertionDisable** disables the starting of any new attempts without affecting existing attempts, so any pending reports from a disabled deferred assertion that are already queued may still mature and be reported.

40. Code coverage control and API

40.1 General

This clause describes the following:

- The SystemVerilog coverage API
- Coverage constants
- Coverage VPI routines
- FSM recognition
- Coverage VPI extensions

40.2 Overview

This clause defines the coverage API in SystemVerilog.

40.2.1 SystemVerilog coverage API

The following criteria are used within this API:

- a) This API shall be similar for all coverages. A wide number of coverage types are available, with possibly different sets offered by different vendors. Maintaining a common interface across all the different types enhances portability and ease of use.
- b) At a minimum, the following types of coverage shall be supported:
 - 1) Statement coverage
 - 2) Toggle coverage
 - 3) Finite state machine (FSM) coverage
 - i) FSM states
 - ii) FSM transitions
 - 3) Assertion coverage
- c) Coverage APIs shall be extensible in a transparent manner, i.e., adding a new coverage type shall not break any existing coverage usage.
- d) This API shall provide means to obtain coverage information from specific subhierarchies of the design without requiring the user to enumerate all instances in those hierarchies.

40.2.2 Nomenclature

The following terms are used in this standard:

- **assertion coverage:** For each assertion, whether it has had at least one success. Implementations permit querying for further details, such as attempt counts, success counts, failure counts and failure coverage.
- **finite state machine (FSM) coverage:** The number of states in an FSM that this simulation reached. This standard does not require FSM automatic extraction, but a standard mechanism to force specific extraction is available via pragmas.
- **statement coverage:** Whether a statement has been executed. *Statement* is anything defined as a statement in the LRM. *Covered* means it executed at least once. Some implementations also permit querying the execution count. The granularity of statement coverage can be per-statement or per-statement block depending on the query (see [40.5.3](#) for details).

- **toggle coverage:** For each bit of every signal (wire and register), whether that bit has both a 0 value and a 1 value. *Full coverage* means both are seen; otherwise, some implementations can query for *partial coverage*. Some implementations also permit querying the toggle count of each bit.

These terms define the primitives for each coverage type. Over instances or blocks, the coverage number is merely the sum of all contained primitives in that instance or block.

40.3 SystemVerilog real-time coverage access

This subclause describes the mechanisms in SystemVerilog through which SystemVerilog code can query and control coverage information. Coverage information is provided to SystemVerilog by means of a number of built-in system functions (described in [40.3.2](#)) using a number of predefined constants (described in [40.3.1](#)) to describe the types of coverage and the control actions to be performed.

40.3.1 Predefined coverage constants in SystemVerilog

The following predefined ``define` macros represent basic real-time coverage capabilities accessible directly from SystemVerilog:

- Coverage control

```
`define SV_COV_START      0
`define SV_COV_STOP      1
`define SV_COV_RESET     2
`define SV_COV_CHECK     3
```

- Scope definition (hierarchy traversal/accumulation type)

```
`define SV_COV_MODULE    10
`define SV_COV_HIER     11
```

- Coverage type identification

```
`define SV_COV_ASSERTION 20
`define SV_COV_FSM_STATE 21
`define SV_COV_STATEMENT 22
`define SV_COV_TOGGLE    23
```

- Status results

```
`define SV_COV_OVERFLOW  -2
`define SV_COV_ERROR    -1
`define SV_COV_NOCOV    0
`define SV_COV_OK       1
`define SV_COV_PARTIAL  2
```

40.3.2 Built-in coverage access system functions

40.3.2.1 \$coverage_control

```
$coverage_control(control_constant,
                  coverage_type,
                  scope_def,
                  modules_or_instance)
```

This function is used to control or query coverage availability in the specified portion of the hierarchy. The following control options are available:

- ``SV_COV_START`, if possible, starts collecting coverage information in the specified hierarchy. There is no effect if coverage is already being collected. Coverage is automatically started at the beginning of simulation for all portions of the hierarchy enabled for coverage.
- ``SV_COV_STOP` stops collecting coverage information in the specified hierarchy. There is no effect if coverage is not being collected.
- ``SV_COV_RESET` resets all available coverage information in the specified hierarchy. There is no effect if coverage not available.
- ``SV_COV_CHECK` checks whether coverage information can be obtained from the specified hierarchy. The existence of coverage information does not imply that coverage is being collected, as the coverage could have been stopped.

The return value is a ``define` name, with the value indicating the success of the action.

- ``SV_COV_OK`, on a check operation, denotes that coverage is fully available in the specified hierarchy. For all other operations, it represents successful and complete execution of the desired operation.
- ``SV_COV_ERROR`, on all operations, means that the control operation failed without any effect, typically due to errors in arguments, such as a nonexisting module.
- ``SV_COV_NOCOV`, on a check or start operation, denotes that coverage is not available at any point in the specified hierarchy.
- ``SV_COV_PARTIAL`, on a check or start operation, denotes that coverage is only partially available in the specified hierarchy.

[Table 40-1](#) describes the possible return values for each of the coverage control options.

Table 40-1—Coverage control return values

	<code>`SV_COV_OK</code>	<code>`SV_COV_ERROR</code>	<code>`SV_COV_NOCOV</code>	<code>`SV_COV_PARTIAL</code>
<code>`SV_COV_START</code>	Success	Bad args	No coverage	Partial coverage
<code>`SV_COV_STOP</code>	Success	Bad args	—	—
<code>`SV_COV_RESET</code>	Success	Bad args	—	—
<code>`SV_COV_CHECK</code>	Full coverage	Bad args	No coverage	Partial coverage

Starting coverage on an instance that has already had coverage started via a prior call to **\$coverage_control()** shall have no effect. Similarly, repeated calls to stop or reset coverage shall have no effect.

The hierarchy(ies) being controlled or queried are specified as follows:

- ``SV_MODULE_COV`, "unique module def name" provides coverage of all instances of the given module (the unique module name is a string), excluding any child instances in the instances of the given module. The module definition name can use special notation to describe nested module definitions.
- ``SV_COV_HIER`, "module name" provides coverage of all instances of the given module, including all the hierarchy below.
- ``SV_MODULE_COV`, instance_name provides coverage of the one named instance. The instance is specified as a normal SystemVerilog hierarchical path.

- ``SV_COV_HIER, instance_name` provides coverage of the named instance, plus all the hierarchy below it.

All the permutations are summarized in [Table 40-2](#).

Table 40-2—Instance coverage permutations

Control/query	Definition name	instance.name
<code>`SV_COV_MODULE</code>	The sum of coverage for all instances of the named module, excluding any hierarchy below those instances.	Coverage for just the named instance, excluding any hierarchy in instances below that instance.
<code>`SV_COV_HIER</code>	The sum of coverage for all instances of the named module, including all coverage for all hierarchy below those instances.	Coverage for the named instance and any hierarchy below it.

NOTE—Definition names are represented as strings, whereas instance names are referenced by hierarchical paths. A hierarchical path need not include any `.` if the path refers to an instance in the current context (i.e., normal SystemVerilog hierarchical path rules apply).

See [Figure 40-1](#) for an example of hierarchical instances.

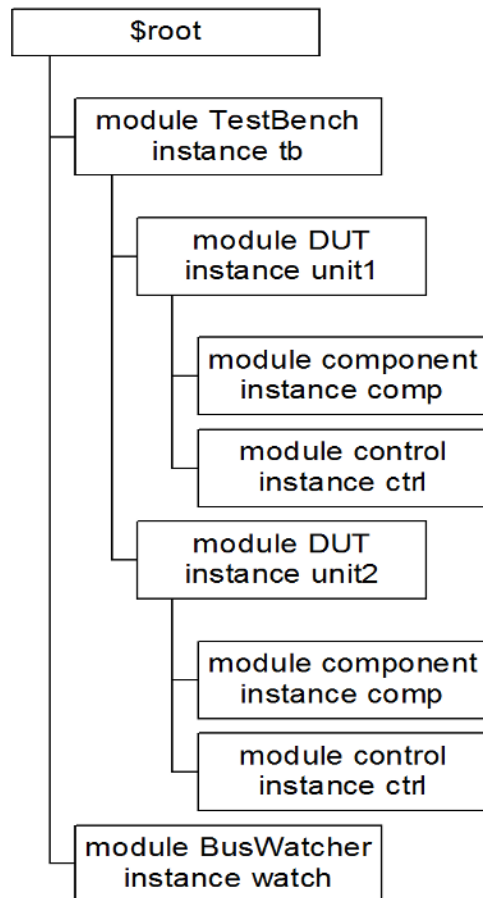

Figure 40-1—Hierarchical instance example

If coverage is enabled on all instances shown in [Figure 40-1](#), then

- `$coverage_control(`SV_COV_CHECK, `SV_COV_TOGGLE, `SV_COV_HIER, $root)` checks all instances to verify they have coverage and, in this case, returns ``SV_COV_OK`.
- `$coverage_control(`SV_COV_RESET, `SV_COV_TOGGLE, `SV_COV_MODULE, "DUT")` resets coverage collection on both instances of the DUT, specifically, `$root.tb.unit1` and `$root.tb.unit2`, but leaves coverage unaffected in all other instances.
- `$coverage_control(`SV_COV_RESET, `SV_COV_TOGGLE, `SV_COV_MODULE, $root.tb.unit1)` resets coverage of only the instance `$root.tb.unit1`, leaving all other instances unaffected.
- `$coverage_control(`SV_COV_STOP, `SV_COV_TOGGLE, `SV_COV_HIER, $root.tb.unit1)` resets coverage of the instance `$root.tb.unit1` and also resets coverage for all instances below it, specifically `$root.tb.unit1.comp` and `$root.tb.unit1.ctrl`.
- `$coverage_control(`SV_COV_START, `SV_COV_TOGGLE, `SV_COV_HIER, "DUT")` starts coverage on all instances of the module DUT and of all hierarchy(ies) below those instances. In this design, coverage is started for the instances `$root.tb.unit1`, `$root.tb.unit1.comp`, `$root.tb.unit1.ctrl`, `$root.tb.unit2`, `$root.tb.unit2.comp`, and `$root.tb.unit2.ctrl`.

40.3.2.2 \$coverage_get_max

`$coverage_get_max(coverage_type, scope_def, modules_or_instance)`

This function obtains the value representing 100% coverage for the specified coverage type over the specified portion of the hierarchy. This value shall remain constant across the duration of the simulation.

NOTE—This value is proportional to the design size and structure; therefore, it also needs to be constant through multiple independent simulations and compilations of the same design, assuming any compilation options do not modify the coverage support or design structure.

The return value is an integer, with the following meanings:

- `-2` (``SV_COV_OVERFLOW`). The value exceeds a number that can be represented as an integer.
- `-1` (``SV_COV_ERROR`). An error occurred (typically due to using incorrect arguments).
- `0` (``SV_COV_NOCOV`). No coverage is available for that coverage type on that/those hierarchy(ies).
- `+pos_num`. This value is the maximum coverage number (where `pos_num > 0`), which is the sum of all coverable items of that type over the given hierarchy(ies).

The scope of this function is specified per `$coverage_control()` (see [40.3.2.1](#)).

40.3.2.3 \$coverage_get

`$coverage_get(coverage_type, scope_def, modules_or_instance)`

This function obtains the current coverage value for the given coverage type over the given portion of the hierarchy. This number can be converted to a coverage percentage by use of the following equation:

$$\text{coverage\%} = \frac{\text{coverage_get}()}{\text{coverage_get_max}()} \times 100$$

The return value follows the same pattern as `$coverage_get_max()` (see [40.3.2.2](#)), but with `pos_num` representing the current coverage level, i.e., the number of the coverable items that have been covered in this/these hierarchy(ies).

The scope of this function is specified per **\$coverage_control()** (see [40.3.2.1](#)).

The return value is an integer, with the following meanings:

- `-2` (``SV_COV_OVERFLOW`). The value exceeds a number that can be represented as an integer.
- `-1` (``SV_COV_ERROR`). An error occurred (typically due to using incorrect arguments).
- `0` (``SV_COV_NOCOV`). No coverage is available for that coverage type on that/those hierarchy(ies).
- `+pos_num`. This value is the maximum coverage number (where `pos_num > 0`), which is the sum of all coverable items of that type over the given hierarchy(ies).

40.3.2.4 \$coverage_merge

\$coverage_merge(coverage_type, "name")

This function loads and merges coverage data for the specified coverage into the simulator. `name` is an arbitrary string used by the tool, in an implementation-specific way, to locate the appropriate coverage database, i.e., tools are allowed to store coverage files any place they want with any extension they want as long as the user can retrieve the information by asking for a specific saved name from that coverage database. If `name` does not exist or does not correspond to a coverage database from the same design, an error shall occur. If an error occurs during loading, the coverage numbers generated by this simulation might not be meaningful.

The return values from this function are as follows:

- ``SV_COV_OK`. The coverage data have been found and merged.
- ``SV_COV_NOCOV`. The coverage data have been found, but did not contain the coverage type requested.
- ``SV_COV_ERROR`. The coverage data were not found, or they did not correspond to this design, or another error occurred.

40.3.2.5 \$coverage_save

\$coverage_save(coverage_type, "name")

This function saves the current state of coverage to the tool's coverage database and associates it with the given name. This name will be mapped in an implementation-specific way into some file or set of files in the coverage database. Data saved to the database shall be retrieved later by using **\$coverage_merge()** and supplying the same name. Saving coverage shall not have any effect on the state of coverage in this simulation.

The return values from this function are as follows:

- ``SV_COV_OK`. The coverage data were successfully saved.
- ``SV_COV_NOCOV`. No such coverage is available in this design (nothing was saved).
- ``SV_COV_ERROR`. Some error occurred during the save. If an error occurs, the tool shall automatically remove the coverage database entry for `name` to preserve the coverage database integrity. It is not an error to overwrite a previously existing `name`.

Details:

- 1) The coverage database format is implementation dependent.
- 2) Mapping of names to actual directories or files is implementation dependent. There is no requirement that a coverage name map to any specific set of files or directories.

40.4 FSM recognition

Coverage tools need to have automatic recognition of many of the common FSM coding idioms in SystemVerilog. This standard does not attempt to describe or require any specific automatic FSM recognition mechanisms. However, this standard does prescribe a means by which nonautomatic FSM extraction occurs. The presence of any of these standard FSM description additions shall override the tool's default extraction mechanism.

Identification of an FSM consists of identifying the following items:

- The state register (or expression)
- The next state register (this is optional)
- The legal states

40.4.1 Specifying signal that holds current state

Use the following pragma to identify the vector signal that holds the current state of the FSM:

```
/* tool state_vector signal_name */
```

where *tool* and *state_vector* are required keywords. This pragma needs to be specified inside the module definition where the signal is declared.

Another pragma is also required that specifies an enumeration name for the FSM. This enumeration name is also specified for the next state and any possible states, associating them with each other as part of the same FSM. There are two ways to do this:

- Use the same pragma as above:

```
/* tool state_vector signal_name enum enumeration_name */
```

- Use a separate pragma in the signal's declaration:

```
/* tool state_vector signal_name */  
logic [7:0] /* tool enum enumeration_name */ signal_name;
```

In either case, **enum** is a required keyword. If using a separate pragma, **tool** is also a required keyword, and the pragma needs to be specified immediately after the bit range of the signal.

40.4.2 Specifying part-select that holds current state

A part-select of a vector signal can be used to hold the current state of the FSM. When a coverage tool displays or reports FSM coverage data, it names the FSM after the signal that holds the current state. If a part-select holds the current state in the user's FSM, the user needs to also specify a name for the FSM for the coverage tool to use. The FSM name is not the same as the enumeration name.

Specify the part-select by using the following pragma:

```
/* tool state_vector signal_name[n:n] FSM_name enum enumeration_name */
```

40.4.3 Specifying concatenation that holds current state

Like specifying a part-select, a concatenation of signals can be specified to hold the current state (when including an FSM name and an enumeration name):

```
/* tool state_vector {signal_name , signal_name, ...} FSM_name enum
   enumeration_name */
```

The concatenation is composed of all the signals specified. Bit-selects or part-selects of signals cannot be used in the concatenation.

40.4.4 Specifying signal that holds next state

The signal that holds the next state of the FSM can also be specified with the pragma that specifies the enumeration name:

```
logic [7:0] /* tool enum enumeration_name */ signal_name
```

This pragma can be omitted if, and only if, the FSM does not have a signal for the next state.

40.4.5 Specifying current and next state signals in same declaration

The tool assumes the first signal following the pragma holds the current state and the next signal holds the next state when a pragma is used for specifying the enumeration name in a declaration of multiple signals. For example:

```
/* tool state_vector cs */
logic [1:0] /* tool enum myFSM */ cs, ns, nonstate;
```

In this example, the tool assumes signal *cs* holds the current state and signal *ns* holds the next state. It assumes nothing about signal *nonstate*.

40.4.6 Specifying possible states of FSM

The possible states of the FSM can also be specified with a pragma that includes the following enumeration name:

```
parameter /* tool enum enumeration_name */
s0 = 0,
s1 = 1,
s2 = 2,
s3 = 3;
```

Put this pragma immediately after the keyword *parameter*, unless a bit width for the parameters is used, in which case, specify the pragma immediately after the bit width:

```
parameter [1:0] /* tool enum enumeration_name */
s0 = 0,
s1 = 1,
s2 = 2,
s3 = 3;
```

40.4.7 Pragmas in one-line comments

These pragmas work in both block comments, between the */** and **/* character strings, and one-line comments, following the *//* character string. For example:

```
parameter [1:0] // tool enum enumeration_name
s0 = 0,
s1 = 1,
s2 = 2,
```

```
s3 = 3;
```

40.4.8 Example

See [Figure 40-2](#) for an example of FSM specified with pragmas.

```

module m3;

reg[31:0] cs;
reg[31:0] /* tool enum MY_FSM */ ns;
reg[31:0] clk;
reg[31:0] rst;

// tool state_vector cs enum MY_FSM

parameter // tool enum MY_FSM
p1=10,
p2=11,
p3=12;

endmodule // m3

```

Signal ns holds the next state

Signal cs holds the current state

p1, p2, and p3 are possible states of

Figure 40-2—FSM specified with pragmas

40.5 VPI coverage extensions

40.5.1 VPI entity/relation diagrams related to coverage

40.5.2 Extensions to VPI enumerations

- Coverage control
 - vpiCoverageStart
 - vpiCoverageStop
 - vpiCoverageReset
 - vpiCoverageCheck
 - vpiCoverageMerge
 - vpiCoverageSave
- VPI properties
 - Coverage type properties
 - vpiAssertCoverage
 - vpiFsmStateCoverage
 - vpiStatementCoverage
 - vpiToggleCoverage
 - Coverage status properties
 - vpiCovered
 - vpiCoverMax
 - vpiCoveredCount
 - Assertion-specific coverage status properties
 - vpiAssertAttemptCovered
 - vpiAssertSuccessCovered
 - vpiAssertFailureCovered
 - vpiAssertVacuousSuccessCovered
 - vpiAssertDisableCovered

- vpiAssertKillCovered
- FSM-specific methods
 - vpiFsmStates
 - vpiFsmStateExpression
- FSM handle types (vpi types)
 - vpiFsm
 - vpiFsmHandle

40.5.3 Obtaining coverage information

To obtain coverage information, the **vpi_get()** function is extended with additional VPI properties that can be obtained from existing handles:

```
vpi_get(<coverageType>, instance_handle)
```

returns the number of covered items of the given coverage type in the given instance. Coverage type is one of the coverage type properties described in [40.5.2](#). For example, given coverage type `vpiStatementCoverage`, this call would return the number of covered statements in the instance pointed by `instance_handle`.

```
vpi_get(vpiCovered, assertion_handle)  
vpi_get(vpiCovered, statement_handle)  
vpi_get(vpiCovered, signal_handle)  
vpi_get(vpiCovered, fsm_handle)  
vpi_get(vpiCovered, fsm_state_handle)
```

returns whether the item referenced by the handle has been covered. For handles that can contain multiple coverable entities, such as statement, FSM, and signal handles, the return value indicates how many of the entities have been covered.

- For assertion handle, the coverable entities are assertions.
- For statement handle, the entities are statements.
- For signal handle, the entities are individual signal bits.
- For FSM handle, the entities are FSM states.

For assertions, **vpiCovered** implies that the assertion has been attempted, has succeeded at least once, and has never failed. More detailed coverage information can be obtained for assertions by the following queries:

```
vpi_get(vpiAssertAttemptCovered, assertion_handle)
```

returns the number of times the assertion has been attempted.

```
vpi_get(vpiAssertSuccessCovered, assertion_handle)
```

returns the number of times the assertion has succeeded nonvacuously or, if the assertion handle corresponds to a cover sequence, the number of times the sequence has been matched. Refer to [16.13.6](#) and [16.15](#) for the definition of vacuity.

```
vpi_get(vpiAssertVacuousSuccessCovered, assertion_handle)
```

returns the number of times the assertion has succeeded vacuously. Refer to [16.13.6](#) and [16.15](#) for the definition of vacuity.

```
vpi_get(vpiAssertDisableCovered, assertion_handle)
```

returns the number of times the assertion has reached the disabled state (e.g. as a result of **disable iff** condition becoming true or if an attempt starts when the **disable iff** is true). Refer to [16.13](#) for the definition of disabled evaluation.

```
vpi_get(vpiAssertKillCovered, assertion_handle)
```

returns the number of times the assertion has been killed (e.g. as a result of a control action, see [39.5.2](#)).

```
vpi_get(vpiAssertFailureCovered, assertion_handle)
```

returns the number of times the assertion has failed. For any assertion, the number of attempts that have not yet reached any conclusion (success, failure, disabled, or killed) can be derived from the equation:

$$\text{in progress} = \text{attempts} - (\text{successes} + \text{vacuous success} + \text{disabled} + \text{killed} + \text{failures})$$

The equation does not apply to cover on sequences as there can be multiple matches corresponding to a single attempt. The following example illustrates some of these queries:

```
module covtest;
  bit on = 1, off = 0;
  logic clk;

  initial begin
    clk = 0;
    forever begin
      #10;
      clk = ~clk;
    end
  end

  always @(false) begin
    anvr: assert(on ##1 on); // assertion will not be attempted
  end

  always @(posedge clk) begin
    aundf: assert (on ##[1:$] off); // assertion will not pass or fail
    afail: assert (on ##1 off); // assertion will always fail on 2nd tick
    apass: assert (on ##1 on); // assertion will succeed on each attempt
  end
endmodule
```

For this example, the assertions will have the coverage results shown in [Table 40-3](#).

Table 40-3—Assertion coverage results

	vpiCovered	vpiAssertAttempt-Covered	vpiAssertSuccess-Covered	vpiAssertFailure-Covered
anvr	False	False	False	False
aundf	False	True	False	False

Table 40-3—Assertion coverage results (continued)

	vpiCovered	vpiAssertAttempt-Covered	vpiAssertSuccess-Covered	vpiAssertFailure-Covered
aFAIL	False	True	False	True
aPASS	True	True	True	False

The number of times an item has been covered can be obtained by the **vpiCoveredCount** property:

```
vpi_get(vpiCoveredCount, assertion_handle)
vpi_get(vpiCoveredCount, statement_handle)
vpi_get(vpiCoveredCount, signal_handle)
vpi_get(vpiCoveredCount, fsm_handle)
vpi_get(vpiCoveredCount, fsm_state_handle)
```

returns the number of times each coverable entity referred by the handle has been covered. The handle coverage information is only easily interpretable when the handle points to a unique coverable item (such as an individual statement). When the handle points to an item containing multiple coverable entities (such as a handle to a block statement containing a number of statements), the result is the sum of coverage counts for each of the constituent entities.

```
vpi_get(vpiCoveredMax, assertion_handle)
vpi_get(vpiCoveredMax, statement_handle)
vpi_get(vpiCoveredMax, signal_handle)
vpi_get(vpiCoveredMax, fsm_handle)
vpi_get(vpiCoveredMax, fsm_state_handle)
```

returns the number of coverable entities pointed by the handle. The number returned shall always be 1 when applied to an assertion or FSM state handle.

```
vpi_iterate(vpiFsm, instance-handle)
```

returns an iterator to all FSMs in an instance.

```
vpi_handle(vpiFsmStateExpression, fsm-handle)
```

returns the handle to the signal or expression encoding the FSM state.

```
vpi_iterate(vpiFsmStates, fsm-handle)
```

returns an iterator to all states of an FSM.

```
vpi_get_value(fsm_state_handle, state-handle)
```

returns the value of an FSM state.

40.5.4 Controlling coverage

Control of the collection of coverage shall be through the **vpi_control()** routine:

```
vpi_control(<coverageControl>, <coverageType>, instance_handle)
vpi_control(<coverageControl>, <coverageType>, assertion_handle)
```

Statement, toggle, and FSM coverage are not individually controllable (i.e., they are controllable only at the instance level and not on a per-statement, signal, or FSM basis). The semantics and behavior are per the `$coverage_control()` system function (see [40.3.2.1](#)). *coverageControl* shall be `vpiCoverageStart`, `vpiCoverageStop`, `vpiCoverageReset`, or `vpiCoverageCheck`, as defined in [40.5.2](#). *coverageType* is any one of the VPI coverage type properties (see [40.5.2](#))

To save coverage for the current simulation use the following:

```
vpi_control(coverageSave, <coverageType>, name)
```

as defined in [40.5.2](#). The semantics and behavior are specified per the equivalent system function `$coverage_save()` (see [40.3.2.5](#)).

To merge coverage for the current simulation use the following:

```
vpi_control(vpiCoverageMerge, <coverageType>, name)
```

as defined in [40.5.2](#). The semantics and behavior are specified per the equivalent system function `$coverage_merge()` (see [40.3.2.4](#)).

41. Data read API

This clause has been deprecated. See IEEE Std 1800-2005 for the contents of this clause.

Part Four: Annexes

Annex A

(normative)

Formal syntax

The formal syntax of SystemVerilog is described using Backus-Naur Form (BNF). The syntax of SystemVerilog source is derived from the starting symbol `source_text`. The syntax of a library map file is derived from the starting symbol `library_text`. The conventions used are as follows:

- Keywords and punctuation are in **bold-red** text.
- Syntactic categories are named in nonbold text.
- A vertical bar (|) separates alternatives.
- Square brackets ([]) enclose optional items.
- Braces ({ }) enclose items that can be repeated zero or more times.

The full syntax and semantics of SystemVerilog are not described solely using BNF. The normative text description contained within the clauses and annexes of this standard provide additional details on the syntax and semantics described in this BNF.

A *qualified term* in the syntax is a term such as *array_identifier* for which the “array” portion represents some semantic intent and the “identifier” term indicates that the qualified term reduces to the “identifier” term in the syntax. The syntax does not completely define the semantics of such qualified terms; for example while an identifier which would qualify semantically as an *array_identifier* is created by a declaration, such declaration forms are not explicitly described using *array_identifier* in the syntax.

A.1 Source text

A.1.1 Library source text

```
library_text ::= { library_description }  
library_description ::=  
    library_declaration  
    | include_statement  
    | config_declaration  
    | ;  
library_declaration ::=  
    library library_identifier file_path_spec { , file_path_spec }  
    [ -incdir file_path_spec { , file_path_spec } ] ;  
include_statement ::= include file_path_spec ;
```

A.1.2 SystemVerilog source text

```
source_text ::= [ timeunits_declaration ] { description }  
description ::=  
    module_declaration  
    | udp_declaration  
    | interface_declaration  
    | program_declaration
```

```

| package_declaration
| { attribute_instance } package_item
| { attribute_instance } bind_directive
| config_declaration
module_nonansi_header ::=
    { attribute_instance } module_keyword [ lifetime ] module_identifier
    { package_import_declaration } [ parameter_port_list ] list_of_ports ;
module_ansi_header ::=
    { attribute_instance } module_keyword [ lifetime ] module_identifier
    { package_import_declaration }1 [ parameter_port_list ] [ list_of_port_declarations ] ;
module_declaration ::=
    module_nonansi_header [ timeunits_declaration ] { module_item }
    endmodule [ : module_identifier ]
| module_ansi_header [ timeunits_declaration ] { non_port_module_item }
    endmodule [ : module_identifier ]
| { attribute_instance } module_keyword [ lifetime ] module_identifier ( .* ) ;
    [ timeunits_declaration ] { module_item } endmodule [ : module_identifier ]
| extern module_nonansi_header
| extern module_ansi_header
module_keyword ::= module | macromodule
interface_declaration ::=
    interface_nonansi_header [ timeunits_declaration ] { interface_item }
    endinterface [ : interface_identifier ]
| interface_ansi_header [ timeunits_declaration ] { non_port_interface_item }
    endinterface [ : interface_identifier ]
| { attribute_instance } interface interface_identifier ( .* ) ;
    [ timeunits_declaration ] { interface_item }
    endinterface [ : interface_identifier ]
| extern interface_nonansi_header
| extern interface_ansi_header
interface_nonansi_header ::=
    { attribute_instance } interface [ lifetime ] interface_identifier
    { package_import_declaration } [ parameter_port_list ] list_of_ports ;
interface_ansi_header ::=
    { attribute_instance } interface [ lifetime ] interface_identifier
    { package_import_declaration }1 [ parameter_port_list ] [ list_of_port_declarations ] ;
program_declaration ::=
    program_nonansi_header [ timeunits_declaration ] { program_item }
    endprogram [ : program_identifier ]
| program_ansi_header [ timeunits_declaration ] { non_port_program_item }
    endprogram [ : program_identifier ]
| { attribute_instance } program program_identifier ( .* ) ;
    [ timeunits_declaration ] { program_item }
    endprogram [ : program_identifier ]
| extern program_nonansi_header
| extern program_ansi_header
program_nonansi_header ::=
    { attribute_instance } program [ lifetime ] program_identifier
    { package_import_declaration } [ parameter_port_list ] list_of_ports ;
program_ansi_header ::=
    { attribute_instance } program [ lifetime ] program_identifier

```

```

    { package_import_declaration }1 [ parameter_port_list ] [ list_of_port_declarations ] ;
checker_declaration ::=
    checker checker_identifier [ ( [ checker_port_list ] ) ] ;
    { checker_or_generate_item }
    endchecker [ : checker_identifier ]
class_declaration ::=
    [ virtual ] class [ lifetime ] class_identifier [ parameter_port_list ]
    [ extends class_type [ ( list_of_arguments ) ] ] ;
    { class_item }
    endclass [ : class_identifier ]
package_declaration ::=
    { attribute_instance } package [ lifetime ] package_identifier ;
    [ timeunits_declaration ] { { attribute_instance } package_item }
    endpackage [ : package_identifier ]
timeunits_declaration ::=
    timeunit time_literal [ / time_literal ] ;
    | timeprecision time_literal ;
    | timeunit time_literal ; timeprecision time_literal ;
    | timeprecision time_literal ; timeunit time_literal ;

```

A.1.3 Module parameters and ports

```

parameter_port_list ::=
    # ( list_of_param_assignments { , parameter_port_declaration } )
    | # ( parameter_port_declaration { , parameter_port_declaration } )
    | # ( )
parameter_port_declaration ::=
    parameter_declaration
    | local_parameter_declaration
    | data_type list_of_param_assignments
    | type list_of_type_assignments
list_of_ports ::= ( port { , port } )
list_of_port_declarations2 ::=
    ( [ { attribute_instance } ansi_port_declaration { , { attribute_instance } ansi_port_declaration } ] )
port_declaration ::=
    { attribute_instance } inout_declaration
    | { attribute_instance } input_declaration
    | { attribute_instance } output_declaration
    | { attribute_instance } ref_declaration
    | { attribute_instance } interface_port_declaration
port ::=
    [ port_expression ]
    | . port_identifier ( [ port_expression ] )
port_expression ::=
    port_reference
    | { port_reference { , port_reference } }
port_reference ::=
    port_identifier constant_select
port_direction ::= input | output | inout | ref

```

```

net_port_header ::= [ port_direction ] net_port_type
variable_port_header ::= [ port_direction ] variable_port_type
interface_port_header ::=
    interface_identifier [ . modport_identifier ]
    | interface [ . modport_identifier ]
ansi_port_declaration ::=
    [ net_port_header | interface_port_header ] port_identifier { unpacked_dimension }
    [ = constant_expression ]
    | [ variable_port_header ] port_identifier { variable_dimension } [ = constant_expression ]
    | [ port_direction ] . port_identifier ( [ expression ] )

```

A.1.4 Module items

```

elaboration_system_task ::=
    $fatal [ ( finish_number [ , list_of_arguments ] ) ] ;
    | $error [ ( [ list_of_arguments ] ) ] ;
    | $warning [ ( [ list_of_arguments ] ) ] ;
    | $info [ ( [ list_of_arguments ] ) ] ;
finish_number ::= 0 | 1 | 2
module_common_item ::=
    module_or_generate_item_declaration
    | interface_instantiation
    | program_instantiation
    | assertion_item
    | bind_directive
    | continuous_assign
    | net_alias
    | initial_construct
    | final_construct
    | always_construct
    | loop_generate_construct
    | conditional_generate_construct
    | elaboration_system_task
module_item ::=
    port_declaration ;
    | non_port_module_item
module_or_generate_item ::=
    { attribute_instance } parameter_override
    | { attribute_instance } gate_instantiation
    | { attribute_instance } udp_instantiation
    | { attribute_instance } module_instantiation
    | { attribute_instance } module_common_item
module_or_generate_item_declaration ::=
    package_or_generate_item_declaration
    | genvar_declaration
    | clocking_declaration
    | default clocking clocking_identifier ;
    | default disable iff expression_or_dist ;
non_port_module_item ::=
    generate_region
    | module_or_generate_item

```

```

| specify_block
| { attribute_instance } specparam_declaration
| program_declaration
| module_declaration
| interface_declaration
| timeunits_declaration3
parameter_override ::= defparam list_of_defparam_assignments ;
bind_directive4 ::=
    bind bind_target_scope [ : bind_target_instance_list ] bind_instantiation ;
    | bind bind_target_instance bind_instantiation ;
bind_target_scope ::=
    module_identifier
    | interface_identifier
bind_target_instance ::=
    hierarchical_identifier constant_bit_select
bind_target_instance_list ::=
    bind_target_instance { , bind_target_instance }
bind_instantiation ::=
    program_instantiation
    | module_instantiation
    | interface_instantiation
    | checker_instantiation

```

A.1.5 Configuration source text

```

config_declaration ::=
    config config_identifier ;
    { local_parameter_declaration ; }
    design_statement
    { config_rule_statement }
    endconfig [ : config_identifier ]
design_statement ::= design { [ library_identifier . ] cell_identifier } ;
config_rule_statement ::=
    default_clause liblist_clause ;
    | inst_clause liblist_clause ;
    | inst_clause use_clause ;
    | cell_clause liblist_clause ;
    | cell_clause use_clause ;
default_clause ::= default
inst_clause ::= instance inst_name
inst_name ::= topmodule_identifier { . instance_identifier }
cell_clause ::= cell [ library_identifier . ] cell_identifier
liblist_clause ::= liblist { library_identifier }
use_clause ::= use [ library_identifier . ] cell_identifier [ : config ]
    | use named_parameter_assignment { , named_parameter_assignment } [ : config ]
    | use [ library_identifier . ] cell_identifier named_parameter_assignment
        { , named_parameter_assignment } [ : config ]

```

A.1.6 Interface items

```

interface_or_generate_item ::=
    { attribute_instance } module_common_item
  | { attribute_instance } modport_declaration
  | { attribute_instance } extern_tf_declaration
extern_tf_declaration ::=
    extern method_prototype ;
  | extern forkjoin task_prototype ;
interface_item ::=
    port_declaration ;
  | non_port_interface_item
non_port_interface_item ::=
    generate_region
  | interface_or_generate_item
  | program_declaration
  | interface_declaration
  | timeunits_declaration3

```

A.1.7 Program items

```

program_item ::=
    port_declaration ;
  | non_port_program_item
non_port_program_item ::=
    { attribute_instance } continuous_assign
  | { attribute_instance } module_or_generate_item_declaration
  | { attribute_instance } initial_construct
  | { attribute_instance } final_construct
  | { attribute_instance } concurrent_assertion_item
  | { attribute_instance } timeunits_declaration3
  | program_generate_item
program_generate_item5 ::=
    loop_generate_construct
  | conditional_generate_construct
  | generate_region
  | elaboration_system_task

```

A.1.8 Checker items

```

checker_port_list ::=
    checker_port_item { , checker_port_item }
checker_port_item ::=
    { attribute_instance } property_formal_type port_identifier { variable_dimension }
    [ = property_actual_arg ]
checker_or_generate_item ::=
    checker_or_generate_item_declaration
  | initial_construct
  | checker_always_construct
  | final_construct

```



```

| assertion_item
| checker_generate_item
checker_or_generate_item_declaration ::=
  [ rand ] data_declaration
| function_declaration
| assertion_item_declaration
| covergroup_declaration
| overload_declaration
| genvar_declaration
| clocking_declaration
| default_clocking clocking_identifier ;
| default_disable_iff expression_or_dist ;
| ;

checker_generate_item6 ::=
  loop_generate_construct
| conditional_generate_construct
| generate_region
| elaboration_system_task

checker_always_construct ::= always statement

```

A.1.9 Class items

```

class_item ::=
  { attribute_instance } class_property
| { attribute_instance } class_method
| { attribute_instance } class_constraint
| { attribute_instance } class_declaration
| { attribute_instance } covergroup_declaration
| local_parameter_declaration ;
| parameter_declaration7 ;
| ;

class_property ::=
  { property_qualifier } data_declaration
| const { class_item_qualifier } data_type const_identifier [ = constant_expression ] ;

class_method ::=
  { method_qualifier } task_declaration
| { method_qualifier } function_declaration
| extern { method_qualifier } method_prototype ;
| { method_qualifier } class_constructor_declaration
| extern { method_qualifier } class_constructor_prototype

class_constructor_prototype ::=
  function new ( [ tf_port_list ] ) ;

class_constraint ::=
  constraint_prototype
| constraint_declaration

class_item_qualifier8 ::=
  static
| protected
| local

property_qualifier8 ::=

```

```

    random_qualifier
  | class_item_qualifier
random_qualifier8 ::=
    rand
  | randc
method_qualifier8 ::=
    [ pure ] virtual
  | class_item_qualifier
method_prototype ::=
    task_prototype
  | function_prototype
class_constructor_declaration ::=
    function [ class_scope ] new [ ( [ tf_port_list ] ) ] ;
    { block_item_declaration }
    [ super . new [ ( list_of_arguments ) ] ; ]
    { function_statement_or_null }
    endfunction [ : new ]

```

A.1.10 Constraints

```

constraint_declaration ::= [ static ] constraint constraint_identifier constraint_block
constraint_block ::= { { constraint_block_item } }
constraint_block_item ::=
    solve solve_before_list before solve_before_list ;
  | constraint_expression
solve_before_list ::= solve_before_primary { , solve_before_primary }
solve_before_primary ::= [ implicit_class_handle . | class_scope ] hierarchical_identifier select
constraint_expression ::=
    expression_or_dist ;
  | expression -> constraint_set
  | if ( expression ) constraint_set [ else constraint_set ]
  | foreach ( ps_or_hierarchical_array_identifier [ loop_variables ] ) constraint_set
constraint_set ::=
    constraint_expression
  | { { constraint_expression } }
dist_list ::= dist_item { , dist_item }
dist_item ::= value_range [ dist_weight ]
dist_weight ::=
    := expression
  | :/ expression
constraint_prototype ::= [ constraint_prototype_qualifier ] [ static ] constraint constraint_identifier ;
constraint_prototype_qualifier ::= extern | pure
extern_constraint_declaration ::=
    [ static ] constraint class_scope constraint_identifier constraint_block
identifier_list ::= identifier { , identifier }

```

A.1.11 Package items

```
package_item ::=
    package_or_generate_item_declaration
    | anonymous_program
    | package_export_declaration
    | timeunits_declaration3
package_or_generate_item_declaration ::=
    net_declaration
    | data_declaration
    | task_declaration
    | function_declaration
    | checker_declaration
    | dpi_import_export
    | extern_constraint_declaration
    | class_declaration
    | class_constructor_declaration
    | local_parameter_declaration ;
    | parameter_declaration ;
    | covergroup_declaration
    | overload_declaration
    | assertion_item_declaration
    | ;
anonymous_program ::= program ; { anonymous_program_item } endprogram
anonymous_program_item ::=
    task_declaration
    | function_declaration
    | class_declaration
    | covergroup_declaration
    | class_constructor_declaration
    | ;
```

A.2 Declarations

A.2.1 Declaration types

A.2.1.1 Module parameter declarations

```
local_parameter_declaration ::=
    localparam data_type_or_implicit list_of_param_assignments
    | localparam type list_of_type_assignments
parameter_declaration ::=
    parameter data_type_or_implicit list_of_param_assignments
    | parameter type list_of_type_assignments
specparam_declaration ::=
    specparam [ packed_dimension ] list_of_specparam_assignments ;
```

A.2.1.2 Port declarations

```
inout_declaration ::=
    inout net_port_type list_of_port_identifiers
input_declaration ::=
```

```

    input net_port_type list_of_port_identifiers
  | input variable_port_type list_of_variable_identifiers
output_declaration ::=
    output net_port_type list_of_port_identifiers
  | output variable_port_type list_of_variable_port_identifiers
interface_port_declaration ::=
    interface_identifier list_of_interface_identifiers
  | interface_identifier . modport_identifier list_of_interface_identifiers
ref_declaration ::= ref variable_port_type list_of_port_identifiers

```

A.2.1.3 Type declarations

```

data_declaration9 ::=
    [ const ] [ var ] [ lifetime ] data_type_or_implicit list_of_variable_decl_assignments ;
  | type_declaration
  | package_import_declaration10
  | virtual_interface_declaration
package_import_declaration ::=
    import package_import_item { , package_import_item } ;
package_import_item ::=
    package_identifier :: identifier
  | package_identifier :: *
package_export_declaration ::=
    export *::* ;
  | export package_import_item { , package_import_item } ;
genvar_declaration ::= genvar list_of_genvar_identifiers ;
net_declaration11 ::=
    net_type [ drive_strength | charge_strength ] [ vectorred | scalared ]
    data_type_or_implicit [ delay3 ] list_of_net_decl_assignments ;
type_declaration ::=
    typedef data_type type_identifier { variable_dimension } ;
  | typedef interface_instance_identifier constant_bit_select . type_identifier type_identifier ;
  | typedef [ enum | struct | union | class ] type_identifier ;
lifetime ::= static | automatic

```

A.2.2 Declaration data types

A.2.2.1 Net and variable types

```

casting_type ::= simple_type | constant_primary | signing | string | const
data_type ::=
    integer_vector_type [ signing ] { packed_dimension }
  | integer_atom_type [ signing ]
  | non_integer_type
  | struct_union [ packed [ signing ] ] { struct_union_member { struct_union_member } }
    { packed_dimension }12
  | enum [ enum_base_type ] { enum_name_declaration { , enum_name_declaration } }
    { packed_dimension }
  | string
  | chandle
  | virtual [ interface ] interface_identifier

```

```

| [ class_scope | package_scope ] type_identifier { packed_dimension }
| class_type
| event
| ps_covergroup_identifier
| type_reference13
data_type_or_implicit ::=
    data_type
    | implicit_data_type
implicit_data_type ::= [ signing ] { packed_dimension }
enum_base_type ::=
    integer_atom_type [ signing ]
    | integer_vector_type [ signing ] [ packed_dimension ]
    | type_identifier [ packed_dimension ]14
enum_name_declaration ::=
    enum_identifier [ [ integral_number [ : integral_number ] ] ] [ = constant_expression ]
class_scope ::= class_type ::
class_type ::=
    ps_class_identifier [ parameter_value_assignment ]
    { :: class_identifier [ parameter_value_assignment ] }
integer_type ::= integer_vector_type | integer_atom_type
integer_atom_type ::= byte | shortint | int | longint | integer | time
integer_vector_type ::= bit | logic | reg
non_integer_type ::= shortreal | real | realtime
net_type ::= supply0 | supply1 | tri | triand | trior | trireg | tri0 | tri1 | uwire | wire | wand | wor
net_port_type15 ::=
    [ net_type ] data_type_or_implicit
variable_port_type ::= var_data_type
var_data_type ::= data_type | var data_type_or_implicit
signing ::= signed | unsigned
simple_type ::= integer_type | non_integer_type | ps_type_identifier | ps_parameter_identifier
struct_union_member16 ::=
    { attribute_instance } [ random_qualifier ] data_type_or_void list_of_variable_decl_assignments ;
data_type_or_void ::= data_type | void
struct_union ::= struct | union [ tagged ]
type_reference ::=
    type ( expression17 )
    | type ( data_type )

```

A.2.2.2 Strengths

```

drive_strength ::=
    ( strength0 , strength1 )
    | ( strength1 , strength0 )
    | ( strength0 , highz1 )
    | ( strength1 , highz0 )
    | ( highz0 , strength1 )
    | ( highz1 , strength0 )
strength0 ::= supply0 | strong0 | pull0 | weak0

```

```
strength1 ::= supply1 | strong1 | pull1 | weak1
charge_strength ::= ( small ) | ( medium ) | ( large )
```

A.2.2.3 Delays

```
delay3 ::= # delay_value | # ( mintypmax_expression [ , mintypmax_expression [ ,
    mintypmax_expression ] ] )
delay2 ::= # delay_value | # ( mintypmax_expression [ , mintypmax_expression ] )
delay_value ::=
    unsigned_number
    | real_number
    | ps_identifier
    | time_literal
    | 1step
```

A.2.3 Declaration lists

```
list_of_defparam_assignments ::= defparam_assignment { , defparam_assignment }
list_of_genvar_identifiers ::= genvar_identifier { , genvar_identifier }
list_of_interface_identifiers ::= interface_identifier { unpacked_dimension }
    { , interface_identifier { unpacked_dimension } }
list_of_net_decl_assignments ::= net_decl_assignment { , net_decl_assignment }
list_of_param_assignments ::= param_assignment { , param_assignment }
list_of_port_identifiers ::= port_identifier { unpacked_dimension }
    { , port_identifier { unpacked_dimension } }
list_of_udp_port_identifiers ::= port_identifier { , port_identifier }
list_of_specparam_assignments ::= specparam_assignment { , specparam_assignment }
list_of_tf_variable_identifiers ::= port_identifier { variable_dimension } [ = expression ]
    { , port_identifier { variable_dimension } [ = expression ] }
list_of_type_assignments ::= type_assignment { , type_assignment }
list_of_variable_decl_assignments ::= variable_decl_assignment { , variable_decl_assignment }
list_of_variable_identifiers ::= variable_identifier { variable_dimension }
    { , variable_identifier { variable_dimension } }
list_of_variable_port_identifiers ::= port_identifier { variable_dimension } [ = constant_expression ]
    { , port_identifier { variable_dimension } [ = constant_expression ] }
list_of_virtual_interface_decl ::=
    variable_identifier [ = interface_instance_identifier ]
    { , variable_identifier [ = interface_instance_identifier ] }
```

A.2.4 Declaration assignments

```
defparam_assignment ::= hierarchical_parameter_identifier = constant_mintypmax_expression
net_decl_assignment ::= net_identifier { unpacked_dimension } [ = expression ]
param_assignment ::=
    parameter_identifier { unpacked_dimension } [ = constant_param_expression ]18
specparam_assignment ::=
    specparam_identifier = constant_mintypmax_expression
    | pulse_control_specparam
```

```

type_assignment ::=
    type_identifier [ = data_type ]18
pulse_control_specparam ::=
    PATHPULSE$ = ( reject_limit_value [ , error_limit_value ] )
    | PATHPULSE$specify_input_terminal_descriptor$specify_output_terminal_descriptor
      = ( reject_limit_value [ , error_limit_value ] )
error_limit_value ::= limit_value
reject_limit_value ::= limit_value
limit_value ::= constant_mintypmax_expression
variable_decl_assignment ::=
    variable_identifier { variable_dimension } [ = expression ]
    | dynamic_array_variable_identifier unsized_dimension { variable_dimension }
      [ = dynamic_array_new ]
    | class_variable_identifier [ = class_new ]
class_new19 ::= new [ ( list_of_arguments ) | expression ]
dynamic_array_new ::= new [ expression ] [ ( expression ) ]

```

A.2.5 Declaration ranges

```

unpacked_dimension ::=
    [ constant_range ]
    | [ constant_expression ]
packed_dimension20 ::=
    [ constant_range ]
    | unsized_dimension
associative_dimension ::=
    [ data_type ]
    | [ * ]
variable_dimension ::=
    unsized_dimension
    | unpacked_dimension
    | associative_dimension
    | queue_dimension
queue_dimension ::= [ $ [ : constant_expression ] ]
unsized_dimension ::= [ ]

```

A.2.6 Function declarations

```

function_data_type_or_implicit ::=
    data_type_or_void
    | implicit_data_type
function_declaration ::= function [ lifetime ] function_body_declaration
function_body_declaration ::=
    function_data_type_or_implicit
    [ interface_identifier . | class_scope ] function_identifier ;
    { tf_item_declaration }
    { function_statement_or_null }
    endfunction [ : function_identifier ]

```

```

| function_data_type_or_implicit
  [ interface_identifier . | class_scope ] function_identifier ( [ tf_port_list ] ) ;
{ block_item_declaration }
{ function_statement_or_null }
endfunction [ : function_identifier ]

function_prototype ::= function data_type_or_void function_identifier ( [ tf_port_list ] )

dpi_import_export ::=
  import dpi_spec_string [ dpi_function_import_property ] [ c_identifier = ] dpi_function_proto ;
| import dpi_spec_string [ dpi_task_import_property ] [ c_identifier = ] dpi_task_proto ;
| export dpi_spec_string [ c_identifier = ] function function_identifier ;
| export dpi_spec_string [ c_identifier = ] task task_identifier ;

dpi_spec_string ::= "DPI-C" | "DPI"

dpi_function_import_property ::= context | pure

dpi_task_import_property ::= context

dpi_function_proto21,22 ::= function_prototype

dpi_task_proto22 ::= task_prototype

```

A.2.7 Task declarations

```

task_declaration ::= task [ lifetime ] task_body_declaration

task_body_declaration ::=
  [ interface_identifier . | class_scope ] task_identifier ;
  { tf_item_declaration }
  { statement_or_null }
  endtask [ : task_identifier ]
| [ interface_identifier . | class_scope ] task_identifier ( [ tf_port_list ] ) ;
  { block_item_declaration }
  { statement_or_null }
  endtask [ : task_identifier ]

tf_item_declaration ::=
  block_item_declaration
| tf_port_declaration

tf_port_list ::=
  tf_port_item { , tf_port_item }

tf_port_item23 ::=
  { attribute_instance }
  [ tf_port_direction ] [ var ] data_type_or_implicit
  [ port_identifier { variable_dimension } [ = expression ] ]

tf_port_direction ::= port_direction | const ref

tf_port_declaration ::=
  { attribute_instance } tf_port_direction [ var ] data_type_or_implicit list_of_tf_variable_identifiers ;

task_prototype ::= task task_identifier ( [ tf_port_list ] )

```

A.2.8 Block item declarations

```

block_item_declaration ::=
  { attribute_instance } data_declaration
| { attribute_instance } local_parameter_declaration ;

```

| { attribute_instance } parameter_declaration ;
| { attribute_instance } overload_declaration
| { attribute_instance } let_declaration

overload_declaration ::=

bind overload_operator **function** data_type function_identifier (overload_proto_formals) ;

overload_operator ::= + | ++ | - | -- | * | ** | / | % | == | != | < | <= | > | >= | =

overload_proto_formals ::= data_type { , data_type }

A.2.9 Interface declarations

virtual_interface_declaration ::=

virtual [**interface**] interface_identifier [parameter_value_assignment] [. modport_identifier]
list_of_virtual_interface_decl ;

modport_declaration ::= **modport** modport_item { , modport_item } ;

modport_item ::= modport_identifier (modport_ports_declaration { , modport_ports_declaration })

modport_ports_declaration ::=

{ attribute_instance } modport_simple_ports_declaration
| { attribute_instance } modport_tf_ports_declaration
| { attribute_instance } modport_clocking_declaration

modport_clocking_declaration ::= **clocking** clocking_identifier

modport_simple_ports_declaration ::=

port_direction modport_simple_port { , modport_simple_port }

modport_simple_port ::=

port_identifier
| . port_identifier ([expression])

modport_tf_ports_declaration ::=

import_export modport_tf_port { , modport_tf_port }

modport_tf_port ::=

method_prototype
| tf_identifier

import_export ::= **import** | **export**

A.2.10 Assertion declarations

concurrent_assertion_item ::=

[block_identifier :] concurrent_assertion_statement
| checker_instantiation

concurrent_assertion_statement ::=

assert_property_statement
| assume_property_statement
| cover_property_statement
| cover_sequence_statement
| restrict_property_statement

assert_property_statement ::=

assert property (property_spec) action_block

assume_property_statement ::=

assume property (property_spec) action_block

cover_property_statement ::=

cover property (property_spec) statement_or_null

```

expect_property_statement ::=
    expect ( property_spec ) action_block
cover_sequence_statement ::=
    cover sequence ( [clocking_event] [ disable iff ( expression_or_dist ) ]
        sequence_expr ) statement_or_null
restrict_property_statement ::=
    restrict property ( property_spec ) ;
property_instance ::=
    ps_or_hierarchical_property_identifier [ ( [ property_list_of_arguments ] ) ]
property_list_of_arguments ::=
    [property_actual_arg] { , [property_actual_arg] } { , . identifier ( [property_actual_arg] ) }
    | . identifier ( [property_actual_arg] ) { , . identifier ( [property_actual_arg] ) }
property_actual_arg ::=
    property_expr
    | sequence_actual_arg
assertion_item_declaration ::=
    property_declaration
    | sequence_declaration
    | let_declaration
property_declaration ::=
    property property_identifier [ ( [ property_port_list ] ) ] ;
    { assertion_variable_declaration }
    property_statement_spec
    endproperty [ : property_identifier ]
property_port_list ::=
    property_port_item { , property_port_item }
property_port_item ::=
    { attribute_instance } [ local [ property_lvar_port_direction ] ] property_formal_type
    port_identifier {variable_dimension} [ = property_actual_arg ]
property_lvar_port_direction ::= input
property_formal_type ::=
    sequence_formal_type
    | property
property_spec ::=
    [clocking_event] [ disable iff ( expression_or_dist ) ] property_expr
property_statement_spec ::=
    [ clocking_event ] [ disable iff ( expression_or_dist ) ] property_statement
property_statement ::=
    property_expr ;
    | case ( expression_or_dist ) property_case_item { property_case_item } endcase
    | if ( expression_or_dist ) property_expr [ else property_expr ]
property_case_item ::=
    expression_or_dist { , expression_or_dist } : property_statement
    | default [ : ] property_statement
property_expr ::=
    sequence_expr
    | strong ( sequence_expr )
    | weak ( sequence_expr )
    | ( property_expr )
    | not property_expr

```

```

| property_expr or property_expr
| property_expr and property_expr
| sequence_expr |-> property_expr
| sequence_expr |=> property_expr
| property_statement
| sequence_expr #-# property_expr
| sequence_expr ## property_expr
| nexttime property_expr
| nexttime [ constant_expression ] property_expr
| s_nexttime property_expr
| s_nexttime [ constant_expression ] property_expr
| always property_expr
| always [ cycle_delay_const_range_expression ] property_expr
| s_always [ constant_range ] property_expr
| s_eventually property_expr
| eventually [ constant_range ] property_expr
| s_eventually [ cycle_delay_const_range_expression ] property_expr
| property_expr until property_expr
| property_expr s_until property_expr
| property_expr until_with property_expr
| property_expr s_until_with property_expr
| property_expr implies property_expr
| property_expr iff property_expr
| accept_on ( expression_or_dist ) property_expr
| reject_on ( expression_or_dist ) property_expr
| sync_accept_on ( expression_or_dist ) property_expr
| sync_reject_on ( expression_or_dist ) property_expr
| property_instance
| clocking_event property_expr

sequence_declaration ::=
  sequence sequence_identifier [ ( [ sequence_port_list ] ) ] ;
    { assertion_variable_declaration }
    sequence_expr ;
  endsequence [ : sequence_identifier ]

sequence_port_list ::=
  sequence_port_item { , sequence_port_item }

sequence_port_item ::=
  { attribute_instance } [ local [ sequence_lvar_port_direction ] ] sequence_formal_type
  port_identifier { variable_dimension } [ = sequence_actual_arg ]

sequence_lvar_port_direction ::= input | inout | output

sequence_formal_type ::=
  data_type_or_implicit
  | sequence
  | event
  | untyped

sequence_expr ::=
  cycle_delay_range sequence_expr { cycle_delay_range sequence_expr }
  | sequence_expr cycle_delay_range sequence_expr { cycle_delay_range sequence_expr }
  | expression_or_dist [ boolean_abbrev ]
  | sequence_instance [ sequence_abbrev ]
  | ( sequence_expr { , sequence_match_item } ) [ sequence_abbrev ]
  | sequence_expr and sequence_expr

```

```

| sequence_expr intersect sequence_expr
| sequence_expr or sequence_expr
| first_match ( sequence_expr { , sequence_match_item } )
| expression_or_dist throughout sequence_expr
| sequence_expr within sequence_expr
| clocking_event sequence_expr
cycle_delay_range ::=
    ## constant_primary
    | ## [ cycle_delay_const_range_expression ]
    | ## [*]
    | ## [+]
sequence_method_call ::=
    sequence_instance . method_identifier
sequence_match_item ::=
    operator_assignment
    | inc_or_dec_expression
    | subroutine_call
sequence_instance ::=
    ps_or_hierarchical_sequence_identifier [ ( [ sequence_list_of_arguments ] ) ]
sequence_list_of_arguments ::=
    [sequence_actual_arg] { , [sequence_actual_arg] } { , . identifier ( [sequence_actual_arg] ) }
    | . identifier ( [sequence_actual_arg] ) { , . identifier ( [sequence_actual_arg] ) }
sequence_actual_arg ::=
    event_expression
    | sequence_expr
boolean_abbrev ::=
    consecutive_repetition
    | non_consecutive_repetition
    | goto_repetition
sequence_abbrev ::= consecutive_repetition
consecutive_repetition ::=
    [* const_or_range_expression ]
    | [*]
    | [+]
non_consecutive_repetition ::= [= const_or_range_expression ]
goto_repetition ::= [-> const_or_range_expression ]
const_or_range_expression ::=
    constant_expression
    | cycle_delay_const_range_expression
cycle_delay_const_range_expression ::=
    constant_expression : constant_expression
    | constant_expression : $
expression_or_dist ::= expression [ dist { dist_list } ]
assertion_variable_declaration ::=
    var_data_type list_of_variable_decl_assignments ;
let_declaration ::=
    let let_identifier [ ( [ let_port_list ] ) ] = expression ;
let_identifier ::=
    identifier

```

```

let_port_list ::=
    let_port_item { , let_port_item }
let_port_item ::=
    { attribute_instance } let_formal_type port_identifier { variable_dimension } [ = expression ]
let_formal_type ::=
    data_type_or_implicit
let_expression ::=
    [ package_scope ] let_identifier [ ( [ let_list_of_arguments ] ) ]
let_list_of_arguments ::=
    [ let_actual_arg ] { , [ let_actual_arg ] } { , . identifier ( [ let_actual_arg ] ) }
    | . identifier ( [ let_actual_arg ] ) { , . identifier ( [ let_actual_arg ] ) }
let_actual_arg ::=
    expression

```

A.2.11 Covergroup declarations

```

covergroup_declaration ::=
    covergroup covergroup_identifier [ ( [ tf_port_list ] ) ] [ coverage_event ] ;
    { coverage_spec_or_option }
    endgroup [ : covergroup_identifier ]
coverage_spec_or_option ::=
    { attribute_instance } coverage_spec
    | { attribute_instance } coverage_option ;
coverage_option ::=
    option.member_identifier = expression
    | type_option.member_identifier = constant_expression
coverage_spec ::=
    cover_point
    | cover_cross
coverage_event ::=
    clocking_event
    | with function sample ( [ tf_port_list ] )
    | @@ ( block_event_expression )
block_event_expression ::=
    block_event_expression or block_event_expression
    | begin hierarchical_btf_identifier
    | end hierarchical_btf_identifier
hierarchical_btf_identifier ::=
    hierarchical_tf_identifier
    | hierarchical_block_identifier
    | hierarchical_identifier [ class_scope ] method_identifier
cover_point ::= [ cover_point_identifier : ] coverpoint expression [ iff ( expression ) ] bins_or_empty
bins_or_empty ::=
    { { attribute_instance } { bins_or_options ; } }
    | ;
bins_or_options ::=
    coverage_option
    | [ wildcard ] bins_keyword bin_identifier [ [ [ expression ] ] ] = { open_range_list } [ iff ( expression ) ]
    | [ wildcard ] bins_keyword bin_identifier [ [ ] ] = trans_list [ iff ( expression ) ]

```

```

| bins_keyword bin_identifier [ [ [ expression ] ] ] = default [ iff ( expression ) ]
| bins_keyword bin_identifier = default sequence [ iff ( expression ) ]
bins_keyword ::= bins | illegal_bins | ignore_bins
range_list ::= value_range { , value_range }
trans_list ::= ( trans_set ) { , ( trans_set ) }
trans_set ::= trans_range_list { => trans_range_list }
trans_range_list ::=
    trans_item
    | trans_item [* repeat_range ]
    | trans_item [-> repeat_range ]
    | trans_item [= repeat_range ]
trans_item ::= range_list
repeat_range ::=
    expression
    | expression : expression
cover_cross ::=
    [ cross_identifier : ] cross list_of_coverpoints [ iff ( expression ) ] select_bins_or_empty
list_of_coverpoints ::= cross_item , cross_item { , cross_item }
cross_item ::=
    cover_point_identifier
    | variable_identifier
select_bins_or_empty ::=
    { { bins_selection_or_option ; } }
    | ;
bins_selection_or_option ::=
    { attribute_instance } coverage_option
    | { attribute_instance } bins_selection
bins_selection ::= bins_keyword bin_identifier = select_expression [ iff ( expression ) ]
select_expression ::=
    select_condition
    | ! select_condition
    | select_expression && select_expression
    | select_expression || select_expression
    | ( select_expression )
select_condition ::= bins_of ( bins_expression ) [ intersect { open_range_list } ]
bins_expression ::=
    variable_identifier
    | cover_point_identifier [ . bin_identifier ]
open_range_list ::= open_value_range { , open_value_range }
open_value_range ::= value_range24

```

A.3 Primitive instances

A.3.1 Primitive instantiation and instances

```

gate_instantiation ::=
    cmos_switchtype [delay3] cmos_switch_instance { , cmos_switch_instance } ;

```

```

| enable_gatetype [drive_strength] [delay3] enable_gate_instance { , enable_gate_instance } ;
| mos_switchtype [delay3] mos_switch_instance { , mos_switch_instance } ;
| n_input_gatetype [drive_strength] [delay2] n_input_gate_instance { , n_input_gate_instance } ;
| n_output_gatetype [drive_strength] [delay2] n_output_gate_instance
  { , n_output_gate_instance } ;
| pass_en_switchtype [delay2] pass_enable_switch_instance { , pass_enable_switch_instance } ;
| pass_switchtype pass_switch_instance { , pass_switch_instance } ;
| pulldown [pulldown_strength] pull_gate_instance { , pull_gate_instance } ;
| pullup [pullup_strength] pull_gate_instance { , pull_gate_instance } ;
cmos_switch_instance ::= [ name_of_instance ] ( output_terminal , input_terminal ,
  ncontrol_terminal , pcontrol_terminal )
enable_gate_instance ::= [ name_of_instance ] ( output_terminal , input_terminal , enable_terminal )
mos_switch_instance ::= [ name_of_instance ] ( output_terminal , input_terminal , enable_terminal )
n_input_gate_instance ::= [ name_of_instance ] ( output_terminal , input_terminal { , input_terminal } )
n_output_gate_instance ::= [ name_of_instance ] ( output_terminal { , output_terminal } ,
  input_terminal )
pass_switch_instance ::= [ name_of_instance ] ( inout_terminal , inout_terminal )
pass_enable_switch_instance ::= [ name_of_instance ] ( inout_terminal , inout_terminal ,
  enable_terminal )
pull_gate_instance ::= [ name_of_instance ] ( output_terminal )

```

A.3.2 Primitive strengths

```

pulldown_strength ::=
  ( strength0 , strength1 )
| ( strength1 , strength0 )
| ( strength0 )
pullup_strength ::=
  ( strength0 , strength1 )
| ( strength1 , strength0 )
| ( strength1 )

```

A.3.3 Primitive terminals

```

enable_terminal ::= expression
inout_terminal ::= net_lvalue
input_terminal ::= expression
ncontrol_terminal ::= expression
output_terminal ::= net_lvalue
pcontrol_terminal ::= expression

```

A.3.4 Primitive gate and switch types

```

cmos_switchtype ::= cmos | rcmos
enable_gatetype ::= bufif0 | bufif1 | notif0 | notif1
mos_switchtype ::= nmos | pmos | rnmos | rpmos
n_input_gatetype ::= and | nand | or | nor | xor | xnor

```

```
n_output_gatetype ::= buf | not
pass_en_switchtype ::= tranif0 | tranif1 | rtranif1 | rtranif0
pass_switchtype ::= tran | rtran
```

A.4 Instantiations

A.4.1 Instantiation

A.4.1.1 Module instantiation

```
module_instantiation ::=
    module_identifier [ parameter_value_assignment ] hierarchical_instance { , hierarchical_instance } ;
parameter_value_assignment ::= # ( [ list_of_parameter_assignments ] )
list_of_parameter_assignments ::=
    ordered_parameter_assignment { , ordered_parameter_assignment }
    | named_parameter_assignment { , named_parameter_assignment }
ordered_parameter_assignment ::= param_expression
named_parameter_assignment ::= . parameter_identifier ( [ param_expression ] )
hierarchical_instance ::= name_of_instance ( [ list_of_port_connections ] )
name_of_instance ::= instance_identifier { unpacked_dimension }
list_of_port_connections25 ::=
    ordered_port_connection { , ordered_port_connection }
    | named_port_connection { , named_port_connection }
ordered_port_connection ::= { attribute_instance } [ expression ]
named_port_connection ::=
    { attribute_instance } . port_identifier [ ( [ expression ] ) ]
    | { attribute_instance } .*
```

A.4.1.2 Interface instantiation

```
interface_instantiation ::=
    interface_identifier [ parameter_value_assignment ] hierarchical_instance { , hierarchical_instance } ;
```

A.4.1.3 Program instantiation

```
program_instantiation ::=
    program_identifier [ parameter_value_assignment ] hierarchical_instance { , hierarchical_instance } ;
```

A.4.1.4 Checker instantiation

```
checker_instantiation ::=
    checker_identifier name_of_instance ( [list_of_checker_port_connections] ) ;
list_of_checker_port_connections25 ::=
    ordered_checker_port_connection { , ordered_checker_port_connection }
    | named_checker_port_connection { , named_checker_port_connection }
ordered_checker_port_connection ::= { attribute_instance } [ property_actual_arg ]
named_checker_port_connection ::=
    { attribute_instance } . port_identifier [ ( [ property_actual_arg ] ) ]
    | { attribute_instance } .*
```

A.4.2 Generated instantiation

```
generate_region ::=
    generate { generate_item } endgenerate
loop_generate_construct ::=
    for ( genvar_initialization ; genvar_expression ; genvar_iteration )
        generate_block
genvar_initialization ::=
    [ genvar ] genvar_identifier = constant_expression
genvar_iteration ::=
    genvar_identifier assignment_operator genvar_expression
    | inc_or_dec_operator genvar_identifier
    | genvar_identifier inc_or_dec_operator
conditional_generate_construct ::=
    if_generate_construct
    | case_generate_construct
if_generate_construct ::=
    if ( constant_expression ) generate_block [ else generate_block ]
case_generate_construct ::=
    case ( constant_expression ) case_generate_item { case_generate_item } endcase
case_generate_item ::=
    constant_expression { , constant_expression } : generate_block
    | default [ : ] generate_block
generate_block ::=
    generate_item
    | [ generate_block_identifier : ] begin [ : generate_block_identifier ]
        { generate_item }
    end [ : generate_block_identifier ]
generate_item26 ::=
    module_or_generate_item
    | interface_or_generate_item
    | checker_or_generate_item
```

A.5 UDP declaration and instantiation

A.5.1 UDP declaration

```
udp_nonansi_declaration ::=
    { attribute_instance } primitive udp_identifier ( udp_port_list ) ;
udp_ansi_declaration ::=
    { attribute_instance } primitive udp_identifier ( udp_declaration_port_list ) ;
udp_declaration ::=
    udp_nonansi_declaration udp_port_declaration { udp_port_declaration }
    udp_body
    endprimitive [ : udp_identifier ]
    | udp_ansi_declaration
    udp_body
    endprimitive [ : udp_identifier ]
    | extern udp_nonansi_declaration
```

```
| extern udp_ansi_declaration
| { attribute_instance } primitive udp_identifier ( .* ) ;
  { udp_port_declaration }
  udp_body
endprimitive [ : udp_identifier ]
```

A.5.2 UDP ports

```
udp_port_list ::= output_port_identifier , input_port_identifier { , input_port_identifier }
udp_declaration_port_list ::= udp_output_declaration , udp_input_declaration { , udp_input_declaration }
udp_port_declaration ::=
  udp_output_declaration ;
  | udp_input_declaration ;
  | udp_reg_declaration ;
udp_output_declaration ::=
  { attribute_instance } output port_identifier
  | { attribute_instance } output reg port_identifier [ = constant_expression ]
udp_input_declaration ::= { attribute_instance } input list_of_udp_port_identifiers
udp_reg_declaration ::= { attribute_instance } reg variable_identifier
```

A.5.3 UDP body

```
udp_body ::= combinational_body | sequential_body
combinational_body ::= table combinational_entry { combinational_entry } endtable
combinational_entry ::= level_input_list : output_symbol ;
sequential_body ::= [ udp_initial_statement ] table sequential_entry { sequential_entry } endtable
udp_initial_statement ::= initial output_port_identifier = init_val ;
init_val ::= 1'b0 | 1'b1 | 1'bx | 1'bX | 1'B0 | 1'B1 | 1'Bx | 1'BX | 1 | 0
sequential_entry ::= seq_input_list : current_state : next_state ;
seq_input_list ::= level_input_list | edge_input_list
level_input_list ::= level_symbol { level_symbol }
edge_input_list ::= { level_symbol } edge_indicator { level_symbol }
edge_indicator ::= ( level_symbol level_symbol ) | edge_symbol
current_state ::= level_symbol
next_state ::= output_symbol | -
output_symbol ::= 0 | 1 | x | X
level_symbol ::= 0 | 1 | x | X | ? | b | B
edge_symbol ::= r | R | f | F | p | P | n | N | *
```

A.5.4 UDP instantiation

```
udp_instantiation ::= udp_identifier [ drive_strength ] [ delay2 ] udp_instance { , udp_instance } ;
udp_instance ::= [ name_of_instance ] ( output_terminal , input_terminal { , input_terminal } )
```

A.6 Behavioral statements

A.6.1 Continuous assignment and net alias statements

```
continuous_assign ::=  
    assign [ drive_strength ] [ delay3 ] list_of_net_assignments ;  
    | assign [ delay_control ] list_of_variable_assignments ;  
list_of_net_assignments ::= net_assignment { , net_assignment }  
list_of_variable_assignments ::= variable_assignment { , variable_assignment }  
net_alias ::= alias net_lvalue = net_lvalue { = net_lvalue } ;  
net_assignment ::= net_lvalue = expression
```

A.6.2 Procedural blocks and assignments

```
initial_construct ::= initial statement_or_null  
always_construct ::= always_keyword statement  
always_keyword ::= always | always_comb | always_latch | always_ff  
final_construct ::= final function_statement  
blocking_assignment ::=  
    variable_lvalue = delay_or_event_control expression  
    | nonrange_variable_lvalue = dynamic_array_new  
    | [ implicit_class_handle . | class_scope | package_scope ] hierarchical_variable_identifier  
        select = class_new  
    | operator_assignment  
operator_assignment ::= variable_lvalue assignment_operator expression  
assignment_operator ::=  
    = | += | -= | *= | /= | %= | &= | |= | ^= | <<= | >>= | <<<= | >>>=  
nonblocking_assignment ::=  
    variable_lvalue <= [ delay_or_event_control ] expression  
procedural_continuous_assignment ::=  
    assign variable_assignment  
    | deassign variable_lvalue  
    | force variable_assignment  
    | force net_assignment  
    | release variable_lvalue  
    | release net_lvalue  
variable_assignment ::= variable_lvalue = expression
```

A.6.3 Parallel and sequential blocks

```
action_block ::=  
    statement_or_null  
    | [ statement ] else statement_or_null  
seq_block ::=  
    begin [ : block_identifier ] { block_item_declaration } { statement_or_null }  
    end [ : block_identifier ]  
par_block ::=  
    fork [ : block_identifier ] { block_item_declaration } { statement_or_null }
```

join_keyword [: block_identifier]
join_keyword ::= **join** | **join_any** | **join_none**

A.6.4 Statements

statement_or_null ::=
statement
| { attribute_instance } ;
statement ::= [block_identifier :] { attribute_instance } statement_item
statement_item ::=
blocking_assignment ;
| nonblocking_assignment ;
| procedural_continuous_assignment ;
| case_statement
| conditional_statement
| inc_or_dec_expression ;
| subroutine_call_statement
| disable_statement
| event_trigger
| loop_statement
| jump_statement
| par_block
| procedural_timing_control_statement
| seq_block
| wait_statement
| procedural_assertion_statement
| clocking_drive ;
| randsequence_statement
| randcase_statement
| expect_property_statement
function_statement ::= statement
function_statement_or_null ::=
function_statement
| { attribute_instance } ;
variable_identifier_list ::= variable_identifier { , variable_identifier }

A.6.5 Timing control statements

procedural_timing_control_statement ::=
procedural_timing_control statement_or_null
delay_or_event_control ::=
delay_control
| event_control
| **repeat** (expression) event_control
delay_control ::=
delay_value
| # (mintypmax_expression)
event_control ::=
@ hierarchical_event_identifier
| @ (event_expression)

```
| @*  
| @ (*)  
| @ ps_or_hierarchical_sequence_identifier  
event_expression27 ::=  
    [ edge_identifier ] expression [ iff expression ]  
| sequence_instance [ iff expression ]  
| event_expression or event_expression  
| event_expression , event_expression  
| ( event_expression )  
procedural_timing_control ::=  
    delay_control  
| event_control  
| cycle_delay  
jump_statement ::=  
    return [ expression ] ;  
| break ;  
| continue ;  
wait_statement ::=  
    wait ( expression ) statement_or_null  
| wait fork ;  
| wait_order ( hierarchical_identifier { , hierarchical_identifier } ) action_block  
event_trigger ::=  
    -> hierarchical_event_identifier ;  
| ->> [ delay_or_event_control ] hierarchical_event_identifier ;  
disable_statement ::=  
    disable hierarchical_task_identifier ;  
| disable hierarchical_block_identifier ;  
| disable fork ;
```

A.6.6 Conditional statements

```
conditional_statement ::=  
    [ unique_priority ] if ( cond_predicate ) statement_or_null  
    { else if ( cond_predicate ) statement_or_null }  
    [ else statement_or_null ]  
unique_priority ::= unique | unique0 | priority  
cond_predicate ::=  
    expression_or_cond_pattern { &&& expression_or_cond_pattern }  
expression_or_cond_pattern ::=  
    expression | cond_pattern  
cond_pattern ::= expression matches pattern
```

A.6.7 Case statements

```
case_statement ::=  
    [ unique_priority ] case_keyword ( case_expression )  
    case_item { case_item } endcase  
| [ unique_priority ] case_keyword ( case_expression ) matches  
    case_pattern_item { case_pattern_item } endcase  
| [ unique_priority ] case ( case_expression ) inside
```

```

    case_inside_item { case_inside_item } endcase
case_keyword ::= case | casez | casex
case_expression ::= expression
case_item ::=
    case_item_expression { , case_item_expression } : statement_or_null
    | default [ : ] statement_or_null
case_pattern_item ::=
    pattern [ &&& expression ] : statement_or_null
    | default [ : ] statement_or_null
case_inside_item ::=
    open_range_list : statement_or_null
    | default [ : ] statement_or_null
case_item_expression ::= expression
randcase_statement ::=
    randcase randcase_item { randcase_item } endcase
randcase_item ::= expression : statement_or_null

```

A.6.7.1 Patterns

```

pattern ::=
    . variable_identifier
    | .*
    | constant_expression
    | tagged member_identifier [ pattern ]
    | '{ pattern { , pattern } }'
    | '{ member_identifier : pattern { , member_identifier : pattern } }'
assignment_pattern ::=
    '{ expression { , expression } }'
    | '{ structure_pattern_key : expression { , structure_pattern_key : expression } }'
    | '{ array_pattern_key : expression { , array_pattern_key : expression } }'
    | '{ constant_expression { expression { , expression } } }'
structure_pattern_key ::= member_identifier | assignment_pattern_key
array_pattern_key ::= constant_expression | assignment_pattern_key
assignment_pattern_key ::= simple_type | default
assignment_pattern_expression ::=
    [ assignment_pattern_expression_type ] assignment_pattern
assignment_pattern_expression_type ::=
    ps_type_identifier
    | ps_parameter_identifier
    | integer_atom_type
    | type_reference
constant_assignment_pattern_expression28 ::= assignment_pattern_expression
assignment_pattern_net_lvalue ::=
    '{ net_lvalue { , net_lvalue } }'
assignment_pattern_variable_lvalue ::=
    '{ variable_lvalue { , variable_lvalue } }'

```

A.6.8 Looping statements

```
loop_statement ::=
    forever statement_or_null
  | repeat ( expression ) statement_or_null
  | while ( expression ) statement_or_null
  | for ( for_initialization ; expression ; for_step )
    statement_or_null
  | do statement_or_null while ( expression ) ;
  | foreach ( ps_or_hierarchical_array_identifier [ loop_variables ] ) statement
for_initialization ::=
    list_of_variable_assignments
  | for_variable_declaration { , for_variable_declaration }
for_variable_declaration ::=
    data_type variable_identifier = expression { , variable_identifier = expression }
for_step ::= for_step_assignment { , for_step_assignment }
for_step_assignment ::=
    operator_assignment
  | inc_or_dec_expression
  | function_subroutine_call
loop_variables ::= [ index_variable_identifier ] { , [ index_variable_identifier ] }
```

A.6.9 Subroutine call statements

```
subroutine_call_statement ::=
    subroutine_call ;
  | void ' ( function_subroutine_call ) ;
```

A.6.10 Assertion statements

```
assertion_item ::=
    concurrent_assertion_item
  | deferred_immediate_assertion_item
deferred_immediate_assertion_item ::= [ block_identifier : ] deferred_immediate_assertion_statement
procedural_assertion_statement ::=
    concurrent_assertion_statement
  | immediate_assertion_statement
  | checker_instantiation
immediate_assertion_statement ::=
    simple_immediate_assertion_statement
  | deferred_immediate_assertion_statement
simple_immediate_assertion_statement ::=
    simple_immediate_assert_statement
  | simple_immediate_assume_statement
  | simple_immediate_cover_statement
simple_immediate_assert_statement ::=
    assert ( expression ) action_block
simple_immediate_assume_statement ::=
    assume ( expression ) action_block
```

```

simple_immediate_cover_statement ::=
    cover ( expression ) statement_or_null
deferred_immediate_assertion_statement ::=
    deferred_immediate_assert_statement
    | deferred_immediate_assume_statement
    | deferred_immediate_cover_statement
deferred_immediate_assert_statement ::=
    assert #0 ( expression ) action_block
deferred_immediate_assume_statement ::=
    assume #0 ( expression ) action_block
deferred_immediate_cover_statement ::=
    cover #0 ( expression ) statement_or_null

```

A.6.11 Clocking block

```

clocking_declaration ::= [ default ] clocking [ clocking_identifier ] clocking_event ;
    { clocking_item }
    endclocking [ : clocking_identifier ]
    | global clocking [ clocking_identifier ] clocking_event ; endclocking [ : clocking_identifier ]
clocking_event ::=
    @ identifier
    | @ ( event_expression )
clocking_item ::=
    default default_skew ;
    | clocking_direction list_of_clocking_decl_assign ;
    | { attribute_instance } assertion_item_declaration
default_skew ::=
    input clocking_skew
    | output clocking_skew
    | input clocking_skew output clocking_skew
clocking_direction ::=
    input [ clocking_skew ]
    | output [ clocking_skew ]
    | input [ clocking_skew ] output [ clocking_skew ]
    | inout
list_of_clocking_decl_assign ::= clocking_decl_assign { , clocking_decl_assign }
clocking_decl_assign ::= signal_identifier [ = expression ]
clocking_skew ::=
    edge_identifier [ delay_control ]
    | delay_control
clocking_drive ::=
    clockvar_expression <= [ cycle_delay ] expression
cycle_delay ::=
    ## integral_number
    | ## identifier
    | ## ( expression )
clockvar ::= hierarchical_identifier
clockvar_expression ::= clockvar select

```

A.6.12 Randsequence

```
randsequence_statement ::= randsequence ( [ production_identifier ] )  
    production { production }  
    endsequence  
production ::= [ data_type_or_void ] production_identifier [ ( tf_port_list ) ] : rs_rule { | rs_rule } ;  
rs_rule ::= rs_production_list [ := weight_specification [ rs_code_block ] ]  
rs_production_list ::=  
    rs_prod { rs_prod }  
    | rand join [ ( expression ) ] production_item production_item { production_item }  
weight_specification ::=  
    integral_number  
    | ps_identifier  
    | ( expression )  
rs_code_block ::= { { data_declaration } { statement_or_null } }  
rs_prod ::=  
    production_item  
    | rs_code_block  
    | rs_if_else  
    | rs_repeat  
    | rs_case  
production_item ::= production_identifier [ ( list_of_arguments ) ]  
rs_if_else ::= if ( expression ) production_item [ else production_item ]  
rs_repeat ::= repeat ( expression ) production_item  
rs_case ::= case ( case_expression ) rs_case_item { rs_case_item } endcase  
rs_case_item ::=  
    case_item_expression { , case_item_expression } : production_item ;  
    | default [ : ] production_item ;
```

A.7 Specify section

A.7.1 Specify block declaration

```
specify_block ::= specify { specify_item } endspecify  
specify_item ::=  
    specparam_declaration  
    | pulsestyle_declaration  
    | showcanceled_declaration  
    | path_declaration  
    | system_timing_check  
pulsestyle_declaration ::=  
    pulsestyle_oneevent list_of_path_outputs ;  
    | pulsestyle_ondetect list_of_path_outputs ;  
showcancelled_declaration ::=  
    showcancelled list_of_path_outputs ;  
    | noshowcancelled list_of_path_outputs ;
```

A.7.2 Specify path declarations

```

path_declaration ::=
    simple_path_declaration ;
    | edge_sensitive_path_declaration ;
    | state_dependent_path_declaration ;
simple_path_declaration ::=
    parallel_path_description = path_delay_value
    | full_path_description = path_delay_value
parallel_path_description ::=
    ( specify_input_terminal_descriptor [ polarity_operator ] => specify_output_terminal_descriptor )
full_path_description ::=
    ( list_of_path_inputs [ polarity_operator ] *> list_of_path_outputs )
list_of_path_inputs ::=
    specify_input_terminal_descriptor { , specify_input_terminal_descriptor }
list_of_path_outputs ::=
    specify_output_terminal_descriptor { , specify_output_terminal_descriptor }

```

A.7.3 Specify block terminals

```

specify_input_terminal_descriptor ::=
    input_identifier [ [ constant_range_expression ] ]
specify_output_terminal_descriptor ::=
    output_identifier [ [ constant_range_expression ] ]
input_identifier ::= input_port_identifier | inout_port_identifier | interface_identifier.port_identifier
output_identifier ::= output_port_identifier | inout_port_identifier | interface_identifier.port_identifier

```

A.7.4 Specify path delays

```

path_delay_value ::=
    list_of_path_delay_expressions
    | ( list_of_path_delay_expressions )
list_of_path_delay_expressions ::=
    t_path_delay_expression
    | trise_path_delay_expression , tfall_path_delay_expression
    | trise_path_delay_expression , tfall_path_delay_expression , tz_path_delay_expression
    | t01_path_delay_expression , t10_path_delay_expression , t0z_path_delay_expression ,
      tz1_path_delay_expression , t1z_path_delay_expression , tz0_path_delay_expression
    | t01_path_delay_expression , t10_path_delay_expression , t0z_path_delay_expression ,
      tz1_path_delay_expression , t1z_path_delay_expression , tz0_path_delay_expression ,
      t0x_path_delay_expression , tx1_path_delay_expression , t1x_path_delay_expression ,
      tx0_path_delay_expression , txz_path_delay_expression , tzx_path_delay_expression
t_path_delay_expression ::= path_delay_expression
trise_path_delay_expression ::= path_delay_expression
tfall_path_delay_expression ::= path_delay_expression
tz_path_delay_expression ::= path_delay_expression
t01_path_delay_expression ::= path_delay_expression
t10_path_delay_expression ::= path_delay_expression

```

```

t0z_path_delay_expression ::= path_delay_expression
tz1_path_delay_expression ::= path_delay_expression
t1z_path_delay_expression ::= path_delay_expression
tz0_path_delay_expression ::= path_delay_expression
t0x_path_delay_expression ::= path_delay_expression
tx1_path_delay_expression ::= path_delay_expression
t1x_path_delay_expression ::= path_delay_expression
tx0_path_delay_expression ::= path_delay_expression
txz_path_delay_expression ::= path_delay_expression
tzx_path_delay_expression ::= path_delay_expression
path_delay_expression ::= constant_mintypmax_expression
edge_sensitive_path_declaration ::=
  parallel_edge_sensitive_path_description = path_delay_value
  | full_edge_sensitive_path_description = path_delay_value
parallel_edge_sensitive_path_description ::=
  ( [ edge_identifier ] specify_input_terminal_descriptor [ polarity_operator ] =>
    ( specify_output_terminal_descriptor [ polarity_operator ] : data_source_expression ) )
full_edge_sensitive_path_description ::=
  ( [ edge_identifier ] list_of_path_inputs [ polarity_operator ] *>
    ( list_of_path_outputs [ polarity_operator ] : data_source_expression ) )
data_source_expression ::= expression
edge_identifier ::= posedge | negedge | edge
state_dependent_path_declaration ::=
  if ( module_path_expression ) simple_path_declaration
  | if ( module_path_expression ) edge_sensitive_path_declaration
  | ifnone simple_path_declaration
polarity_operator ::= + | -

```

A.7.5 System timing checks

A.7.5.1 System timing check commands

```

system_timing_check ::=
  $setup_timing_check
  | $hold_timing_check
  | $setphold_timing_check
  | $recovery_timing_check
  | $removal_timing_check
  | $crem_timing_check
  | $skew_timing_check
  | $timeskew_timing_check
  | $fullskew_timing_check
  | $period_timing_check
  | $width_timing_check
  | $nochange_timing_check
$setup_timing_check ::=
  $setup ( data_event , reference_event , timing_check_limit [ , [ notifier ] ] ) ;
$hold_timing_check ::=
  $hold ( reference_event , data_event , timing_check_limit [ , [ notifier ] ] ) ;

```

```
$setuphold_timing_check ::=
    $setuphold ( reference_event , data_event , timing_check_limit , timing_check_limit
        [ , [ notifier ] [ , [ timestamp_condition ] [ , [ timecheck_condition ]
            [ , [ delayed_reference ] [ , [ delayed_data ] ] ] ] ] ) ;
$recovery_timing_check ::=
    $recovery ( reference_event , data_event , timing_check_limit [ , [ notifier ] ] ) ;
$removal_timing_check ::=
    $removal ( reference_event , data_event , timing_check_limit [ , [ notifier ] ] ) ;
$recrem_timing_check ::=
    $recrem ( reference_event , data_event , timing_check_limit , timing_check_limit
        [ , [ notifier ] [ , [ timestamp_condition ] [ , [ timecheck_condition ]
            [ , [ delayed_reference ] [ , [ delayed_data ] ] ] ] ] ) ;
$skew_timing_check ::=
    $skew ( reference_event , data_event , timing_check_limit [ , [ notifier ] ] ) ;
$timeskew_timing_check ::=
    $timeskew ( reference_event , data_event , timing_check_limit
        [ , [ notifier ] [ , [ event_based_flag ] [ , [ remain_active_flag ] ] ] ] ) ;
$fullskew_timing_check ::=
    $fullskew ( reference_event , data_event , timing_check_limit , timing_check_limit
        [ , [ notifier ] [ , [ event_based_flag ] [ , [ remain_active_flag ] ] ] ] ) ;
$period_timing_check ::=
    $period ( controlled_reference_event , timing_check_limit [ , [ notifier ] ] ) ;
$width_timing_check ::=
    $width ( controlled_reference_event , timing_check_limit , threshold [ , [ notifier ] ] ) ;
$nochange_timing_check ::=
    $nochange ( reference_event , data_event , start_edge_offset , end_edge_offset [ , [ notifier ] ] ) ;
```

A.7.5.2 System timing check command arguments

```
timecheck_condition ::= mintypmax_expression
controlled_reference_event ::= controlled_timing_check_event
data_event ::= timing_check_event
delayed_data ::=
    terminal_identifier
    | terminal_identifier [ constant_mintypmax_expression ]
delayed_reference ::=
    terminal_identifier
    | terminal_identifier [ constant_mintypmax_expression ]
end_edge_offset ::= mintypmax_expression
event_based_flag ::= constant_expression
notifier ::= variable_identifier
reference_event ::= timing_check_event
remain_active_flag ::= constant_mintypmax_expression
timestamp_condition ::= mintypmax_expression
start_edge_offset ::= mintypmax_expression
threshold ::= constant_expression
timing_check_limit ::= expression
```

A.7.5.3 System timing check event definitions

```

timing_check_event ::=
    [timing_check_event_control] specify_terminal_descriptor [ &&& timing_check_condition ]
controlled_timing_check_event ::=
    timing_check_event_control specify_terminal_descriptor [ &&& timing_check_condition ]
timing_check_event_control ::=
    posedge
    | negedge
    | edge
    | edge_control_specifier
specify_terminal_descriptor ::=
    specify_input_terminal_descriptor
    | specify_output_terminal_descriptor
edge_control_specifier ::= edge [ edge_descriptor { , edge_descriptor } ]
edge_descriptor29 ::= 01 | 10 | z_or_x zero_or_one | zero_or_one z_or_x
zero_or_one ::= 0 | 1
z_or_x ::= x | X | z | Z
timing_check_condition ::=
    scalar_timing_check_condition
    | ( scalar_timing_check_condition )
scalar_timing_check_condition ::=
    expression
    | ~ expression
    | expression == scalar_constant
    | expression === scalar_constant
    | expression != scalar_constant
    | expression !== scalar_constant
scalar_constant ::= 1'b0 | 1'b1 | 1'B0 | 1'B1 | 'b0 | 'b1 | 'B0 | 'B1 | 1 | 0

```

A.8 Expressions

A.8.1 Concatenations

```

concatenation ::=
    { expression { , expression } }
constant_concatenation ::=
    { constant_expression { , constant_expression } }
constant_multiple_concatenation ::= { constant_expression constant_concatenation }
module_path_concatenation ::= { module_path_expression { , module_path_expression } }
module_path_multiple_concatenation ::= { constant_expression module_path_concatenation }
multiple_concatenation ::= { expression concatenation }30
streaming_concatenation ::= { stream_operator [ slice_size ] stream_concatenation }
stream_operator ::= >> | <<
slice_size ::= simple_type | constant_expression
stream_concatenation ::= { stream_expression { , stream_expression } }
stream_expression ::= expression [ with [ array_range_expression ] ]

```

```
array_range_expression ::=
    expression
    | expression : expression
    | expression +: expression
    | expression -: expression
empty_queue31 ::= { }
```

A.8.2 Subroutine calls

```
constant_function_call ::= function_subroutine_call32
tf_call33 ::= ps_or_hierarchical_tf_identifier { attribute_instance } [ ( list_of_arguments ) ]
system_tf_call ::=
    system_tf_identifier [ ( list_of_arguments ) ]
    | system_tf_identifier ( data_type [ , expression ] )
subroutine_call ::=
    tf_call
    | system_tf_call
    | method_call
    | [ std:: ] randomize_call
function_subroutine_call ::= subroutine_call
list_of_arguments ::=
    [ expression ] { , [ expression ] } { , . identifier ( [ expression ] ) }
    | . identifier ( [ expression ] ) { , . identifier ( [ expression ] ) }
method_call ::= method_call_root . method_call_body
method_call_body ::=
    method_identifier { attribute_instance } [ ( list_of_arguments ) ]
    | built_in_method_call
built_in_method_call ::=
    array_manipulation_call
    | randomize_call
array_manipulation_call ::=
    array_method_name { attribute_instance }
    [ ( list_of_arguments ) ]
    [ with ( expression ) ]
randomize_call ::=
    randomize { attribute_instance }
    [ ( [ variable_identifier_list | null ] ) ]
    [ with [ ( [ identifier_list ] ) ] constraint_block ]34
method_call_root ::= primary | implicit_class_handle
array_method_name ::=
    method_identifier | unique | and | or | xor
```

A.8.3 Expressions

```
inc_or_dec_expression ::=
    inc_or_dec_operator { attribute_instance } variable_lvalue
    | variable_lvalue { attribute_instance } inc_or_dec_operator
conditional_expression ::= cond_predicate ? { attribute_instance } expression : expression
```

```
constant_expression ::=
    constant_primary
    | unary_operator { attribute_instance } constant_primary
    | constant_expression binary_operator { attribute_instance } constant_expression
    | constant_expression ? { attribute_instance } constant_expression : constant_expression

constant_mintypmax_expression ::=
    constant_expression
    | constant_expression : constant_expression : constant_expression

constant_param_expression ::=
    constant_mintypmax_expression | data_type | $

param_expression ::= mintypmax_expression | data_type

constant_range_expression ::=
    constant_expression
    | constant_part_select_range

constant_part_select_range ::=
    constant_range
    | constant_indexed_range

constant_range ::= constant_expression : constant_expression

constant_indexed_range ::=
    constant_expression +: constant_expression
    | constant_expression -: constant_expression

expression ::=
    primary
    | unary_operator { attribute_instance } primary
    | inc_or_dec_expression
    | ( operator_assignment )
    | expression binary_operator { attribute_instance } expression
    | conditional_expression
    | inside_expression
    | tagged_union_expression

tagged_union_expression ::=
    tagged member_identifier [ expression ]

inside_expression ::= expression inside { open_range_list }

value_range ::=
    expression
    | [ expression : expression ]

mintypmax_expression ::=
    expression
    | expression : expression : expression

module_path_conditional_expression ::= module_path_expression ? { attribute_instance }
    module_path_expression : module_path_expression

module_path_expression ::=
    module_path_primary
    | unary_module_path_operator { attribute_instance } module_path_primary
    | module_path_expression binary_module_path_operator { attribute_instance }
    module_path_expression
    | module_path_conditional_expression

module_path_mintypmax_expression ::=
    module_path_expression
    | module_path_expression : module_path_expression : module_path_expression
```

```
part_select_range ::= constant_range | indexed_range
indexed_range ::=
    expression +: constant_expression
    | expression -: constant_expression
genvar_expression ::= constant_expression
```

A.8.4 Primaries

```
constant_primary ::=
    primary_literal
    | ps_parameter_identifier constant_select
    | speccparam_identifier [ [ constant_range_expression ] ]
    | genvar_identifier35
    | [ package_scope | class_scope ] enum_identifier
    | constant_concatenation [ [ constant_range_expression ] ]
    | constant_multiple_concatenation [ [ constant_range_expression ] ]
    | constant_function_call
    | constant_let_expression
    | ( constant_mintypmax_expression )
    | constant_cast
    | constant_assignment_pattern_expression
    | type_reference36
module_path_primary ::=
    number
    | identifier
    | module_path_concatenation
    | module_path_multiple_concatenation
    | function_subroutine_call
    | ( module_path_mintypmax_expression )
primary ::=
    primary_literal
    | [ class_qualifier | package_scope ] hierarchical_identifier select
    | empty_queue
    | concatenation [ [ range_expression ] ]
    | multiple_concatenation [ [ range_expression ] ]
    | function_subroutine_call
    | let_expression
    | ( mintypmax_expression )
    | cast
    | assignment_pattern_expression
    | streaming_concatenation
    | sequence_method_call
    | this37
    | $38
    | null
class_qualifier := [ local : :39 ] [ implicit_class_handle . | class_scope ]
range_expression ::=
    expression
    | part_select_range
primary_literal ::= number | time_literal | unbased_unsized_literal | string_literal
```



```

time_literal40 ::=
    unsigned_number time_unit
    | fixed_point_number time_unit
time_unit ::= s | ms | us | ns | ps | fs
implicit_class_handle37 ::= this | super | this . super
bit_select ::= { [ expression ] }
select ::=
    [ { . member_identifier bit_select } . member_identifier ] bit_select [ [ part_select_range ] ]
nonrange_select ::=
    [ { . member_identifier bit_select } . member_identifier ] bit_select
constant_bit_select ::= { [ constant_expression ] }
constant_select ::=
    [ { . member_identifier constant_bit_select } . member_identifier ] constant_bit_select
    [ [ constant_part_select_range ] ]
constant_cast ::=
    casting_type ' ( constant_expression )
constant_let_expression ::= let_expression41
cast ::=
    casting_type ' ( expression )

```

A.8.5 Expression left-side values

```

net_lvalue ::=
    ps_or_hierarchical_net_identifier constant_select
    | { net_lvalue { , net_lvalue } }
    | [ assignment_pattern_expression_type ] assignment_pattern_net_lvalue
variable_lvalue ::=
    [ implicit_class_handle . | package_scope ] hierarchical_variable_identifier select42
    | { variable_lvalue { , variable_lvalue } }
    | [ assignment_pattern_expression_type ] assignment_pattern_variable_lvalue
    | streaming_concatenation43
nonrange_variable_lvalue ::=
    [ implicit_class_handle . | package_scope ] hierarchical_variable_identifier nonrange_select

```

A.8.6 Operators

```

unary_operator ::=
    + | - | ! | ~ | & | ~& | | | ~| | ^ | ~^ | ^~
binary_operator ::=
    + | - | * | / | % | == | != | === | !== | ==? | !=? | && | || | **
    | < | <= | > | >= | & | | | ^ | ^~ | ~^ | >> | << | >>> | <<<
    | -> | <->
inc_or_dec_operator ::= ++ | --
unary_module_path_operator ::=
    ! | ~ | & | ~& | | | ~| | ^ | ~^ | ^~
binary_module_path_operator ::=
    == | != | && | || | & | | | ^ | ^~ | ~^

```

A.8.7 Numbers

```

number ::=
    integral_number
    | real_number
integral_number ::=
    decimal_number
    | octal_number
    | binary_number
    | hex_number
decimal_number ::=
    unsigned_number
    | [ size ] decimal_base unsigned_number
    | [ size ] decimal_base x_digit { _ }
    | [ size ] decimal_base z_digit { _ }
binary_number ::= [ size ] binary_base binary_value
octal_number ::= [ size ] octal_base octal_value
hex_number ::= [ size ] hex_base hex_value
sign ::= + | -
size ::= non_zero_unsigned_number
non_zero_unsigned_number29 ::= non_zero_decimal_digit { _ | decimal_digit }
real_number29 ::=
    fixed_point_number
    | unsigned_number [ . unsigned_number ] exp [ sign ] unsigned_number
fixed_point_number29 ::= unsigned_number . unsigned_number
exp ::= e | E
unsigned_number29 ::= decimal_digit { _ | decimal_digit }
binary_value29 ::= binary_digit { _ | binary_digit }
octal_value29 ::= octal_digit { _ | octal_digit }
hex_value29 ::= hex_digit { _ | hex_digit }
decimal_base29 ::= '[s]d' | '[s]D'
binary_base29 ::= '[s]b' | '[s]B'
octal_base29 ::= '[s]o' | '[s]O'
hex_base29 ::= '[s]h' | '[s]H'
non_zero_decimal_digit ::= 1 | 2 | 3 | 4 | 5 | 6 | 7 | 8 | 9
decimal_digit ::= 0 | 1 | 2 | 3 | 4 | 5 | 6 | 7 | 8 | 9
binary_digit ::= x_digit | z_digit | 0 | 1
octal_digit ::= x_digit | z_digit | 0 | 1 | 2 | 3 | 4 | 5 | 6 | 7
hex_digit ::= x_digit | z_digit | 0 | 1 | 2 | 3 | 4 | 5 | 6 | 7 | 8 | 9 | a | b | c | d | e | f | A | B | C | D | E | F
x_digit ::= x | X
z_digit ::= z | Z | ?
unbased_unsized_literal ::= '0' | '1' | 'z_or_x'44

```

A.8.8 Strings

string_literal ::= " { Any_ASCII_Characters } "

A.9 General

A.9.1 Attributes

attribute_instance ::= (* attr_spec { , attr_spec } *)

attr_spec ::= attr_name [= constant_expression]

attr_name ::= identifier

A.9.2 Comments

comment ::=
 one_line_comment
 | block_comment

one_line_comment ::= // comment_text \n

block_comment ::= /* comment_text */

comment_text ::= { Any_ASCII_character }

A.9.3 Identifiers

array_identifier ::= identifier

block_identifier ::= identifier

bin_identifier ::= identifier

c_identifier⁴⁵ ::= [a-zA-Z_] { [a-zA-Z0-9_] }

cell_identifier ::= identifier

checker_identifier ::= identifier

class_identifier ::= identifier

class_variable_identifier ::= variable_identifier

clocking_identifier ::= identifier

config_identifier ::= identifier

const_identifier ::= identifier

constraint_identifier ::= identifier

covergroup_identifier ::= identifier

covergroup_variable_identifier ::= variable_identifier

cover_point_identifier ::= identifier

cross_identifier ::= identifier

dynamic_array_variable_identifier ::= variable_identifier

enum_identifier ::= identifier

escaped_identifier ::= \ {any_ASCII_character_except_white_space} white_space

formal_identifier ::= identifier

function_identifier ::= identifier

```
generate_block_identifier ::= identifier
genvar_identifier ::= identifier
hierarchical_array_identifier ::= hierarchical_identifier
hierarchical_block_identifier ::= hierarchical_identifier
hierarchical_event_identifier ::= hierarchical_identifier
hierarchical_identifier ::= [ $root . ] { identifier constant_bit_select . } identifier
hierarchical_net_identifier ::= hierarchical_identifier
hierarchical_parameter_identifier ::= hierarchical_identifier
hierarchical_property_identifier ::= hierarchical_identifier
hierarchical_sequence_identifier ::= hierarchical_identifier
hierarchical_task_identifier ::= hierarchical_identifier
hierarchical_tf_identifier ::= hierarchical_identifier
hierarchical_variable_identifier ::= hierarchical_identifier
identifier ::=
    simple_identifier
  | escaped_identifier
index_variable_identifier ::= identifier
interface_identifier ::= identifier
interface_instance_identifier ::= identifier
inout_port_identifier ::= identifier
input_port_identifier ::= identifier
instance_identifier ::= identifier
library_identifier ::= identifier
member_identifier ::= identifier
method_identifier ::= identifier
modport_identifier ::= identifier
module_identifier ::= identifier
net_identifier ::= identifier
output_port_identifier ::= identifier
package_identifier ::= identifier
package_scope ::=
    package_identifier ::
  | $unit ::
parameter_identifier ::= identifier
port_identifier ::= identifier
production_identifier ::= identifier
program_identifier ::= identifier
property_identifier ::= identifier
ps_class_identifier ::= [ package_scope ] class_identifier
ps_covergroup_identifier ::= [ package_scope ] covergroup_identifier
ps_identifier ::= [ package_scope ] identifier
ps_or_hierarchical_array_identifier ::=
    [ implicit_class_handle . | class_scope | package_scope ] hierarchical_array_identifier
ps_or_hierarchical_net_identifier ::= [ package_scope ] net_identifier | hierarchical_net_identifier
```

ps_or_hierarchical_property_identifier ::=
 [package_scope] property_identifier
 | hierarchical_property_identifier
ps_or_hierarchical_sequence_identifier ::=
 [package_scope] sequence_identifier
 | hierarchical_sequence_identifier
ps_or_hierarchical_tf_identifier ::= [package_scope] tf_identifier | hierarchical_tf_identifier
ps_parameter_identifier ::=
 [package_scope | class_scope] parameter_identifier
 | { generate_block_identifier [[constant_expression]] . } parameter_identifier
ps_type_identifier ::= [**local** : :³⁹ | package_scope] type_identifier
sequence_identifier ::= identifier
signal_identifier ::= identifier
simple_identifier⁴⁵ ::= [**a-zA-Z_**] { [**a-zA-Z0-9_\$**] }
specparam_identifier ::= identifier
system_tf_identifier⁴⁶ ::= \$ [**a-zA-Z0-9_\$**] { [**a-zA-Z0-9_\$**] }
task_identifier ::= identifier
tf_identifier ::= identifier
terminal_identifier ::= identifier
topmodule_identifier ::= identifier
type_identifier ::= identifier
udp_identifier ::= identifier
variable_identifier ::= identifier

A.9.4 White space

white_space ::= space | tab | newline | eof⁴⁷

A.10 Footnotes (normative)

- 1) A package_import_declaration in a module_ansi_header, interface_ansi_header, or program_ansi_header shall be followed by a parameter_port_list or list_of_port_declarations, or both.
- 2) The list_of_port_declarations syntax is explained in 23.2.2.2, which also imposes various semantic restrictions, e.g., a **ref** port shall be of a variable type and an **inout** port shall not be. It shall be illegal to initialize a port that is not a variable **output** port or to specify a default value for a port that is not an **input** port.
- 3) A timeunits_declaration shall be legal as a non_port_module_item, non_port_interface_item, non_port_program_item, or package_item only if it repeats and matches a previous timeunits_declaration within the same time scope.
- 4) If the bind_target_scope is an interface_identifier or the bind_target_instance is an interface_instance_identifier, then the bind_instantiation shall be an interface_instantiation or a checker_instantiation.
- 5) It shall be illegal for a program_generate_item to include any item that would be illegal in a program_declaration outside a program_generate_item.
- 6) It shall be illegal for a checker_generate_item to include any item that would be illegal in a checker_declaration outside a checker_generate_item.
- 7) In a parameter_declaration that is a class_item, the **parameter** keyword shall be a synonym for the **local-param** keyword.

- 8) In any one declaration, only one of **protected** or **local** is allowed, only one of **rand** or **randc** is allowed, and **static** and/or **virtual** can appear only once.
- 9) In a `data_declaration` that is not within a procedural context, it shall be illegal to use the **automatic** keyword. In a `data_declaration`, it shall be illegal to omit the explicit `data_type` before a `list_of_variable_decl_assignments` unless the **var** keyword is used.
- 10) It shall be illegal to have an import statement directly within a class scope.
- 11) A `charge_strength` shall only be used with the **trireg** keyword. When the **vectorized** or **scalared** keyword is used, there shall be at least one packed dimension.
- 12) When a packed dimension is used with the **struct** or **union** keyword, the **packed** keyword shall also be used.
- 13) When a `type_reference` is used in a net declaration, it shall be preceded by a net type keyword; and when it is used in a variable declaration, it shall be preceded by the **var** keyword.
- 14) A `type_identifier` shall be legal as an `enum_base_type` if it denotes an `integer_atom_type`, with which an additional packed dimension is not permitted, or an `integer_vector_type`.
- 15) When a `net_port_type` contains a `data_type`, it shall only be legal to omit the explicit `net_type` when declaring an **inout** port.
- 16) It shall be legal to declare a **void** `struct_union_member` only within tagged unions.
- 17) An expression that is used as the argument in a `type_reference` shall not contain any hierarchical references or references to elements of dynamic objects.
- 18) In a `param_assignment` it shall be illegal to omit the `constant_param_expression` except within a `parameter_declaration` in a `parameter_port_list`. In a `type_assignment` it shall be illegal to omit the `data_type` except within a `parameter_declaration` in a `parameter_port_list`.
- 19) In a shallow copy, the expression shall evaluate to an object handle.
- 20) In `packed_dimension`, `unsized_dimension` is permitted only as the sole packed dimension in a DPI import declaration; see `dpi_function_proto` and `dpi_task_proto`.
- 21) `dpi_function_proto` return types are restricted to small values, per [35.5.5](#).
- 22) Formals of `dpi_function_proto` and `dpi_task_proto` cannot use pass-by-reference mode, and class types cannot be passed at all; see [35.5.6](#) for a description of allowed types for DPI formal arguments.
- 23) In a `tf_port_item`, it shall be illegal to omit the explicit `port_identifier` except within a `function_prototype` or `task_prototype`.
- 24) It shall be legal to use the **\$** primary in an `open_value_range` of the form `[expression : $]` or `[$: expression]`.
- 25) The **.*** token shall appear at most once in a list of port connections.
- 26) Within an `interface_declaration`, it shall only be legal for a `generate_item` to be an `interface_or_generate_item`. Within a `module_declaration`, except when also within an `interface_declaration`, it shall only be legal for a `generate_item` to be a `module_or_generate_item`. Within a `checker_declaration`, it shall only be legal for a `generate_item` to be a `checker_or_generate_item`.
- 27) Parentheses are required when an event expression that contains comma-separated event expressions is passed as an actual argument using positional binding.
- 28) In a `constant_assignment_pattern_expression`, all member expressions shall be constant expressions.
- 29) Embedded spaces are illegal.
- 30) In a `multiple_concatenation`, it shall be illegal for the multiplier not to be a `constant_expression` unless the type of the concatenation is **string**.
- 31) **{ }** shall only be legal in the context of a queue.
- 32) In a `constant_function_call`, all arguments shall be `constant_expressions`.
- 33) It shall be illegal to omit the parentheses in a `tf_call` unless the subroutine is a task, void function, or class method. If the subroutine is a nonvoid class function method, it shall be illegal to omit the parentheses if the call is directly recursive.
- 34) In a `randomize_call` that is not a method call of an object of class type (i.e. a scope `randomize`), the optional parenthesized `identifier_list` after the keyword **with** shall be illegal, and the use of **null** shall be illegal.

- 35) A `genvar_identifier` shall be legal in a `constant_primary` only within a `genvar_expression`.
- 36) It shall be legal to use a `type_reference constant_primary` as the `casting_type` in a static cast. It shall be illegal for a `type_reference constant_primary` to be used with any operators except the equality/inequality and case equality/inequality operators.
- 37) `implicit_class_handle` shall only appear within the scope of a `class_declaration` or out-of-block method declaration.
- 38) The `$` primary shall be legal only in a `select` for a queue variable, in an `open_value_range`, or as an entire `sequence_actual_arg` or `property_actual_arg`.
- 39) The `local::` qualifier shall only appear within the scope of an inline constraint block.
- 40) The unsigned number or fixed-point number in `time_literal` shall not be followed by `white_space`.
- 41) In a `constant_let_expression`, all arguments shall be `constant_expressions` and its right hand side shall be a `constant_expression` itself provided that its formal arguments are treated as `constant_primary` there.
- 42) In a `variable_lvalue` that is assigned within a `sequence_match_item` any `select` shall also be a `constant_select`.
- 43) A `streaming_concatenation` expression shall not be nested within another `variable_lvalue`. A `streaming_concatenation` shall not be the target of the increment or decrement operator nor the target of any assignment operator except the simple (`=`) or nonblocking assignment (`<=`) operator.
- 44) The apostrophe (`'`) in `unbased_unsized_literal` shall not be followed by `white_space`.
- 45) A `simple_identifier` or `c_identifier` shall start with an alpha or underscore (`_`) character, shall have at least one character, and shall not have any spaces.
- 46) The `$` character in a `system_tf_identifier` shall not be followed by `white_space`. A `system_tf_identifier` shall not be escaped.
- 47) End of file.

Annex B

(normative)

Keywords

SystemVerilog reserves the keywords listed in [Table B.1](#).

Table B.1—Reserved keywords

accept_on	default	forkjoin
alias	defparam	function
always	design	generate
always_comb	disable	genvar
always_ff	dist	global
always_latch	do	highz0
and	edge	highz1
assert	else	if
assign	end	iff
assume	endcase	ifnone
automatic	endchecker	ignore_bins
before	endclass	illegal_bins
begin	endclocking	implies
bind	endconfig	import
bins	endfunction	includir
binsof	endgenerate	include
bit	endgroup	initial
break	endinterface	inout
buf	endmodule	input
bufif0	endpackage	inside
bufif1	endprimitive	instance
byte	endprogram	int
case	endproperty	integer
casex	endspecify	interface
casez	endsequence	intersect
cell	endtable	join
chandle	endtask	join_any
checker	enum	join_none
class	event	large
clocking	eventually	let
cmos	expect	liblist
config	export	library
const	extends	local
constraint	extern	localparam
context	final	logic
continue	first_match	longint
cover	for	macromodule
covergroup	force	matches
coverpoint	foreach	medium
cross	forever	modport
deassign	fork	module

Table B.1—Reserved keywords (continued)

nand	repeat	timeunit
negedge	restrict	tran
new	return	tranif0
nexttime	rnmos	tranif1
nmos	rpmos	tri
nor	rtran	tri0
noshowcancelled	rtranif0	tri1
not	rtranif1	triand
notif0	s_always	trior
notif1	s_eventually	trireg
null	s_nexttime	type
or	s_until	typedef
output	s_until_with	union
package	scalared	unique
packed	sequence	unique0
parameter	shortint	unsigned
pmos	shortreal	until
posedge	showcancelled	until_with
primitive	signed	untyped
priority	small	use
program	solve	uwire
property	specify	var
protected	specparam	vectored
pull0	static	virtual
pull1	string	void
pulldown	strong	wait
pullup	strong0	wait_order
pulsestyle_ondetect	strong1	wand
pulsestyle_onevent	struct	weak
pure	super	weak0
rand	supply0	weak1
randc	supply1	while
randcase	sync_accept_on	wildcard
randsequence	sync_reject_on	wire
rcmos	table	with
real	tagged	within
realtime	task	wor
ref	this	xnor
reg	throughout	xor
reject_on	time	
release	timeprecision	

Annex C

(normative)

Deprecation

C.1 General

This annex identifies constructs that either

- Have been deprecated from SystemVerilog and no longer appear in this standard
- Are under consideration for deprecation and might be removed from future versions of this standard

C.2 Constructs that have been deprecated

C.2.1 PLI TF and ACC routine libraries

The IEEE Std 1364-2005¹² standard deprecated the Programming Language interface (PLI) libraries containing the task/function (TF) and access (ACC) routines that were contained in previous versions of that standard. These routines were described in Clause 21 through Clause 25, Annex E, and Annex F of IEEE Std 1364-2001. The text of these deprecated clauses and annexes do not appear in this version of the standard. The text can be found in IEEE Std 1364-2001.

C.2.2 \$sampled with a clocking event argument

IEEE Std 1800-2005 17.7.3 required that an explicit or inferred clocking event argument be provided for the \$sampled assertion system function. In this version of the standard, the semantics of \$sampled have been changed to a form that does not depend on a clocking event. Therefore the syntax for defining the clocking event argument to \$sampled is deprecated and does not appear in this version of the standard.

C.2.3 ended sequence method

IEEE Std 1800-2005 17.7.3 required using the .ended sequence method in sequence expressions and the .triggered sequence method in other contexts. Since these two constructs have the same meaning but mutually exclusive usage contexts, in this version of the standard, the .triggered method is allowed to be used in sequence expressions, and the usage of .ended is deprecated and does not appear in this version of the standard.

C.2.4 vpi_free_object()

The semantics of this VPI routine have been clarified to account for the nature of dynamic data in the SystemVerilog information model and the concept of handle validity. It has been renamed vpi_release_handle(), and thus vpi_free_object() has been deprecated.

¹²For information on references, see [Clause 2](#).

C.2.5 Data Read API

IEEE Std 1800-2009 deprecates the Data Read API that was contained in the previous version of the standard. These routines were described in Clause 30 and Annex I of IEEE Std 1800-2005. The text of these deprecated clauses and annexes do not appear in this version of the standard. The text can be found in IEEE Std 1800-2005.

C.2.6 Linked Lists

IEEE Std 1800-2009 deprecates the built-in Linked List package that was contained in the previous version of the standard. This package was described in Annex D of IEEE Std 1800-2005. The text of this deprecated annex does not appear in this version of the standard. The text can be found in IEEE Std 1800-2005.

C.3 Accellera SystemVerilog 3.1a-compatible access to packed data

The Accellera SystemVerilog 3.1a [\[B3\]](#) semantics for `svLogicPackedArrRef` and `svBitPackedArrRef` is deprecated. See [H.13](#) for a full description of Accellera SystemVerilog 3.1a versus IEEE-1800 semantics.

C.4 Constructs identified for deprecation

NOTE—Certain SystemVerilog language features can be simulation inefficient, easily abused, and the source of design problems. These features are being considered for removal from the SystemVerilog language if there is an alternate method for these features.

The SystemVerilog language features that have been identified in this standard as ones that can be removed from SystemVerilog are **defparam** and procedural **assign/deassign**.

C.4.1 Defparam statements

The **defparam** method of specifying the value of a parameter can be a source of design errors and can be an impediment to tool implementation due to its usage of hierarchical paths. The **defparam** statement does not provide a capability that cannot be done by another method that avoids these problems. Therefore, the **defparam** statement is on a deprecation list. In other words, a future revision of IEEE Std 1800 might not require support for this feature. This current standard still requires tools to support the **defparam** statement. However, users are strongly encouraged to migrate their code to use one of the alternate methods of parameter redefinition.

Prior to the acceptance of IEEE Std 1364-2001 (Verilog-2001), it was common practice to change one or more parameters of instantiated modules using a separate **defparam** statement. The **defparam** statements can be a source of tool complexity and design problems.

A **defparam** statement can precede the instance to be modified, can follow the instance to be modified, can be at the end of the file that contains the instance to be modified, can be in a separate file from the instance to be modified, can modify parameters hierarchically that are in turn passed to other **defparam** statements to modify, and can modify the same parameter from two different **defparam** statements (with undefined results). Due to the many ways that a **defparam** can modify parameters, a SystemVerilog compiler cannot resolve the final parameter values for an instance until after all of the design files are compiled.

Prior to IEEE Std 1364-2001, the only other method available to change the values of parameters on instantiated modules was to use implicit in-line parameter redefinition. This method uses `#(parameter_value)` as part of the module instantiation. Implicit in-line parameter redefinition syntax requires that all parameters

up to and including the parameter to be changed shall be placed in the correct order and shall be assigned values.

IEEE Std 1364-2001 introduced explicit in-line parameter redefinition, in the form `#(.parameter_name(value))`, as part of the module instantiation. This method gives the capability to pass parameters by name in the instantiation, which supplies all of the necessary parameter information to the model in the instantiation itself.

The practice of using `defparam` statements is highly discouraged. Engineers are encouraged to take advantage of the explicit in-line parameter redefinition capability.

See [6.20](#) for more details on parameters.

C.4.2 Procedural assign and deassign statements

The procedural `assign` and `deassign` statements can be a source of design errors and can be an impediment to tool implementation. The procedural `assign` and `deassign` statements do not provide a capability that cannot be done by another method that avoids these problems. Therefore, the procedural `assign` and `deassign` statements are on a deprecation list. In other words, a future revision of IEEE Std 1800 might not require support for these statements. This current standard still requires tools to support the procedural `assign` and `deassign` statements. However, users are strongly encouraged to migrate their code to use one of the alternate methods of procedural or continuous assignments.

SystemVerilog has two forms of the `assign` statement, as follows:

- Continuous assignments, placed outside any procedures
- Procedural continuous assignments, placed within a procedure

Continuous assignment statements are a separate process that are active throughout simulation. The continuous assignment statement accurately represents combinational logic at an RTL level of modeling and is frequently used.

Procedural continuous assignment statements become active when the `assign` statement is executed in the procedure. The process can be deactivated using a `deassign` statement. The procedural `assign` and `deassign` statements are seldom needed to model hardware behavior. In the unusual circumstances where the behavior of procedural continuous assignments are required, the same behavior can be modeled using the procedural `force` and `release` statements.

Allowing the `assign` statement to be used both inside and outside a procedural block causes confusion and is a source of errors in SystemVerilog models. The practice of using the `assign` and `deassign` statements inside procedural blocks is highly discouraged.

Annex D

(informative)

Optional system tasks and system functions

D.1 General

The system tasks and system functions described in this annex are for informative purposes only and are not part of this standard.

This annex describes system tasks and system functions which are companions to the system tasks and system functions described in [Clause 20](#) and [Clause 21](#). The system tasks and system functions described in this annex may not be available in all implementations of SystemVerilog. The following system tasks and system functions are described in this annex:

<code>\$countdrivers</code>	[D.2]	<code>\$reset_count</code>	[D.8]
<code>\$getpattern</code>	[D.3]	<code>\$reset_value</code>	[D.8]
<code>\$incsave</code>	[D.9]	<code>\$restart</code>	[D.9]
<code>\$input</code>	[D.4]	<code>\$save</code>	[D.9]
<code>\$key</code>	[D.5]	<code>\$scale</code>	[D.10]
<code>\$list</code>	[D.6]	<code>\$scope</code>	[D.11]
<code>\$log</code>	[D.7]	<code>\$showscopes</code>	[D.12]
<code>\$nokey</code>	[D.5]	<code>\$showvars</code>	[D.13]
<code>\$nolog</code>	[D.7]	<code>\$sreadmemb</code>	[D.14]
<code>\$reset</code>	[D.8]	<code>\$sreadmemh</code>	[D.14]

D.2 \$countdrivers

Syntax:

```
$countdrivers (net, [ net_is_forced, number_of_01x_drivers, number_of_0_drivers,  
number_of_1_drivers, number_of_x_drivers ] );
```

The `$countdrivers` system function is provided to count the number of drivers on a specified net so that bus contention can be identified.

This system function returns a 0 if there is no more than one driver on the net and returns a 1 otherwise (indicating contention). The specified net shall be a scalar or a bit-select of a vector net. The number of arguments to the system function may vary according to how much information is desired.

If additional arguments are supplied to the `$countdrivers` function, each argument returns the information described in [Table D.1](#).

Table D.1—Argument return value for \$countdriver function

Argument	Return value
<code>net_is_forced</code>	1 if net is forced. 0 otherwise.
<code>number_of_01x_drivers</code>	An integer representing the number of drivers on the net that are in 0, 1, or x state. This represents the total number of drivers that are not forced.
<code>number_of_0_drivers</code>	An integer representing the number of drivers on the net that are in 0 state.
<code>number_of_1_drivers</code>	An integer representing the number of drivers on the net that are in 1 state.
<code>number_of_x_drivers</code>	An integer representing the number of drivers on the net that are in x state.

D.3 \$getpattern

Syntax:

```
$getpattern ( mem_element );
```

The system function `$getpattern` provides for fast processing of stimulus patterns that have to be propagated to a large number of scalar inputs. The function reads stimulus patterns that have been loaded into a memory using the `$readmemb` or `$readmemh` system tasks.

Use of this function is limited, however: it may only be used in a continuous assignment statement where the left-hand side is a concatenation of scalar nets and the argument to the system function is a memory element reference.

The following example shows how stimuli stored in a file can be read into a memory using `$readmemb` and applied to the circuit one pattern at a time using `$getpattern`.

The memory `in_mem` is initialized with the stimulus patterns by the `$readmemb` task. The integer variable `index` selects which pattern is being applied to the circuit. The `for` loop increments the integer variable `index` periodically to sequence the patterns.

```
module top;
    parameter in_width = 10,
              patterns = 200,
              delay = 20;
    logic [1:in_width] in_mem[1:patterns];
    integer index;

    // declare scalar inputs
    wire i1,i2,i3,i4,i5,i6,i7,i8,i9,i10;

    // assign patterns to circuit scalar inputs (a new pattern
    // is applied to the circuit each time index changes value)
    assign {i1,i2,i3,i4,i5,i6,i7,i8,i9,i10} = $getpattern(in_mem[index]);

    initial begin
        // read stimulus patterns into memory
        $readmemb("patt.mem", in_mem);
    end
endmodule
```

```
// step through patterns (each assignment
// to index will drive a new pattern onto the circuit
// inputs from the $getpattern system task specified above
for (index = 1; index <= patterns; index = index + 1)
    #delay;
end

// instantiate the circuit module - e.g.,
mod1 cct (o1,o2,o3,o4,o5, i1,i2,i3,i4,i5,i6,i7,i8,i9,i10);

endmodule
```

D.4 \$input

Syntax:

```
$input ("filename");
```

The **\$input** system task allows command input text to come from a named file instead of from the terminal. At the end of the command file, the input is switched back to the terminal.

D.5 \$key and \$nokey

Syntax:

```
$key [ ("filename") ] ;
$nokey ;
```

A key file is created whenever interactive mode is entered for the first time during simulation. The key file contains all of the text that has been typed in from the standard input. The file also contains information about asynchronous interrupts.

The **\$nokey** and **\$key** system tasks are used to disable and reenable output to the key file. An optional file name argument for **\$key** causes the old key file to be closed, a new file to be created, and output to be directed to the new file.

D.6 \$list

Syntax:

```
$list [ ( hierarchical_name ) ] ;
```

When invoked without an argument, **\$list** produces a listing of the module, task, function, or named block that is defined as the current scope setting. If an optional argument is supplied, it shall refer to a specific module, task, function, or named block, in which case the specified object is listed.

D.7 \$log and \$nolog

Syntax:

```
$log [ ("filename" ) ] ;  
$nolog ;
```

A log file contains a copy of all the text that is printed to the standard output. The log file may also contain, at the beginning of the file, the host command that was used to run the tool.

The `$nolog` and `$log` system tasks are used to disable and reenables output to the log file. The `$nolog` task disables output to the log file, while the `$log` task reenables the output. An optional file name argument for `$log` causes the old file to be closed, a new log file to be created, and output to be directed to the new log file.

D.8 \$reset, \$reset_count, and \$reset_value

Syntax:

```
$reset [ ( stop_value [ , reset_value , [ diagnostics_value ] ] ) ] ;  
$reset_count ;  
$reset_value ;
```

The `$reset` system task enables a tool to be reset to its “time 0” state so that processing (e.g., simulation) can begin again.

The `$reset_count` system function keeps track of the number of times the tool is reset. The `$reset_value` system function returns the value specified by the `reset_value` argument to the `$reset` system task. The `$reset_value` system function is used to communicate information from before a reset of a tool to the time 0 state to after the reset.

The following are some of the simulation methods that can be employed with this system task and these system functions:

- Determine the `force` statements a design needs to operate correctly, reset the simulation time to 0, enter these `force` statements, and start to simulate again.
- Reset the simulation time to 0 and apply new stimuli.
- Determine that debug system tasks, such as `$monitor` and `$strobe`, are keeping track of the correct nets or variables, reset the simulation time to 0, and begin simulation again.

The `$reset` system task tells a tool to return the processing of the design to its logical state at time 0. When a tool executes the `$reset` system task, it takes the following actions to stop the process:

- a) Disables all concurrent activity, initiated in either initial or always procedures in the source description or through interactive mode (disables, for example, all `force` and `assign` statements, the current `$monitor` system task, and any other active tasks).
- b) Cancels all scheduled simulation events.

After a simulation tool executes the `$reset` system task, the simulation is in the following state:

- The simulation time is 0.
- All variables and nets contain their initial values.
- The tool begins to execute the first procedural statements in all `initial` and `always` procedures.

The `stop_value` argument indicates if interactive mode or processing is entered immediately after resetting of the tool. A value of 0 or no argument causes interactive mode to be entered after resetting the tool. A nonzero value passed to `$reset` causes the tool to begin processing immediately.

The `reset_value` argument is an integer that specifies the value that shall be returned by the `$reset_value` system function after the tool is reset. All declared integers return to their initial value after reset, but entering an integer as this argument allows access to what its value was before the reset with the `$reset_value` system function. This argument provides a means of communicating information from before the reset of a tool to after the reset of the tool.

The `diagnostic_value` specifies the kind of diagnostic messages a tool displays before it resets the time to 0. Increasing integer values results in increased information. A value of zero results in no diagnostic message.

D.9 \$save, \$restart, and \$incsave

Three system tasks `$save`, `$restart`, and `$incsave` work in conjunction with one another to save the complete state of simulation into a permanent file so that the simulation state can be reloaded at a later time and processing can continue where it left off.

Syntax:

```
$save("filename ");  
$restart("filename");  
$incsave("incremental_filename ");
```

All three system tasks take a file name as an argument. The file name has to be supplied as a string enclosed in quotation marks.

The `$save` system task saves the complete state into the file specified as an argument.

The `$incsave` system task saves only what has changed since the last invocation of `$save`. It is not possible to do an incremental save on any file other than the one produced by the last `$save`.

The `$restart` system task restores a previously saved state from a specified file.

Restarting from an incremental save is similar to restarting from a full save, except that the name of the incremental save file is specified in the restart command. The full save file on which the incremental save file was based shall still be present, as it is required for a successful restart. If the full save file has been changed in any way since the incremental save was performed, errors will result.

The incremental restart is useful for going back in time. If a full save is performed near the beginning of processing and an incremental save is done at regular intervals, then going back in time is as simple as restarting from the appropriate file.

For example:

```
module checkpoint;  
  
    initial  
        #500 $save("save.dat");    // full save  
  
    always begin                    // incremental save every 10000 units,
```

```
                                // files are recycled every 40000 units
#100000 $incsave("incl.dat");
#100000 $incsave("inc2.dat");
#100000 $incsave("inc3.dat");
#100000 $incsave("inc4.dat");
    end
endmodule
```

D.10 \$scale

Syntax:

```
$scale ( hierarchical_name ) ;
```

The **\$scale** function takes a time value from a module with one time unit to be used in a module with a different time unit. The time value is converted from the time unit of one module to the time unit of the module that invokes **\$scale**.

D.11 \$scope

Syntax:

```
$scope ( hierarchical_name ) ;
```

The **\$scope** system task allows a particular level of hierarchy to be specified as the scope for identifying objects. This task accepts a single argument that shall be the complete hierarchical name of a module, task, function, or named block. The initial setting of the interactive scope is the first top-level module.

D.12 \$showscopes

Syntax:

```
$showscopes [ ( n ) ] ;
```

The **\$showscopes** system task produces a complete list of modules, tasks, functions, and named blocks that are defined at the current scope level. An optional integer argument can be given to **\$showscopes**. A non-zero argument value causes all the modules, tasks, functions, and named blocks in or below the current hierarchical scope to be listed. No argument or a zero value results in only objects at the current scope level being listed.

D.13 \$showvars

Syntax:

```
$showvars [ ( list_of_variables ) ] ;
```

The **\$showvars** system task produces status information for reg and net variables, both scalar and vector. When invoked without arguments, **\$showvars** displays the status of all variables in the current scope. When invoked with a list of variables, **\$showvars** shows only the status of the specified variables. If the list of variables includes a bit-select or part-select of a vector, then the status information for all the bits of that vector are displayed.

D.14 **\$sreadmemb** and **\$sreadmemh**

Syntax:

```
$sreadmemb ( mem_name , start_address , finish_address , string { , string } ) ;
```

```
$sreadmemh ( mem_name , start_address , finish_address , string { , string } ) ;
```

The system tasks **\$sreadmemb** and **\$sreadmemh** load data into memory `mem_name` from a character string.

The **\$sreadmemh** and **\$sreadmemb** system tasks take memory data values and addresses as string literal arguments. The start and finish addresses indicate the bounds for where the data from strings will be stored in the memory. These strings take the same format as the strings that appear in the input files passed as arguments to **\$readmemb** and **\$readmemh**.

Annex E

(informative)

Optional compiler directives

E.1 General

The compiler directives described in this annex are for informative purposes only and are not part of this standard.

This annex describes additional compiler directives as companions to the compiler directives described in [Clause 22](#). The compiler directives described in this annex may not be available in all implementations of SystemVerilog. The following compiler directives are described in this annex:

<code>`default_decay_time</code>	[E.2]	<code>`delay_mode_path</code>	[E.5]
<code>`default_trireg_strength</code>	[E.3]	<code>`delay_mode_unit</code>	[E.6]
<code>`delay_mode_distributed</code>	[E.4]	<code>`delay_mode_zero</code>	[E.7]

E.2 ``default_decay_time`

The ``default_decay_time` compiler directive specifies the decay time for the trireg nets that do not have any decay time specified in the declaration. This compiler directive applies to all of the trireg nets in all the modules that follow it in the source description. An argument specifying the charge decay time shall be used with this compiler directive.

Syntax:

```
`default_decay_time integer_constant | real_constant | infinite
```

Example 1—The following example shows how the default decay time for all trireg nets can be set to 100 time units:

```
`default_decay_time 100
```

Example 2—The following example shows how to avoid charge decay on trireg nets:

```
`default_decay_time infinite
```

The keyword `infinite` specifies no charge decay for all the trireg nets that do not have decay time specification.

E.3 ``default_trireg_strength`

The ``default_trireg_strength` compiler directive specifies the charge strength of `trireg` nets.

Syntax:

```
`default_trireg_strength integer_constant
```

The integer constant shall be between 0 and 250. It indicates the relative strength of the capacitance on the trireg net.

E.4 ``delay_mode_distributed`

The ``delay_mode_distributed` compiler directive specifies the distributed delay mode for all modules that follow this directive in the source description.

Syntax:

```
`delay_mode_distributed
```

This compiler directive shall be used before the declaration of the module whose delay mode is being controlled.

E.5 ``delay_mode_path`

The ``delay_mode_path` compiler directive specifies the path delay mode for all modules that follow this directive in the source description.

Syntax:

```
`delay_mode_path
```

This compiler directive shall be used before the declaration of the module whose delay mode is being controlled.

E.6 ``delay_mode_unit`

The ``delay_mode_unit` compiler directive specifies the unit delay mode for all modules that follow this directive in the source description.

Syntax:

```
`delay_mode_unit
```

This compiler directive shall be used before the declaration of the module whose delay mode is being controlled.

E.7 ``delay_mode_zero`

The ``delay_mode_zero` compiler directive specifies the zero delay mode for all modules that follow this directive in the source description.

Syntax:

```
`delay_mode_zero
```

This compiler directive shall be used before the declaration of the module whose delay mode is being controlled.

Annex F

(normative)

Formal semantics of concurrent assertions

F.1 General

This annex presents a formal semantics for SystemVerilog concurrent assertions. Immediate assertions and coverage statements are not discussed here.

F.2 Overview

Throughout this annex, “assertion” is used to mean “concurrent assertion” and “iff” is used to mean “if and only if”. The semantics is defined by a relation that determines when a finite or infinite word (i.e., trace) satisfies an assertion. Intuitively, such a word represents a sequence of valuations of SystemVerilog variables sampled at the finest relevant granularity of time (e.g., at the granularity of simulator cycles). The process by which such words are produced is closely related to the SystemVerilog scheduling semantics and is not defined here. In this annex, words are assumed to be sequences of elements, each element being either a set of atomic propositions or one of two special symbols used as placeholders when extending finite words. The atomic propositions are not further defined. The meaning of satisfaction of a SystemVerilog Boolean expression by a set of atomic propositions is assumed to be understood.

The semantics in this annex describe each evaluation of a concurrent assertion, but there may be many evaluations for each assertion implied within SystemVerilog code. This annex does not define the semantics of queueing an instance of a concurrent assertion in procedural code ([16.15.6](#)). Once a pending procedural assertion instance has matured, the semantics of the resulting property evaluation is defined by this annex. If multiple evaluation attempts of a particular procedural concurrent assertion all mature, each of those matured attempts is described separately by the equations in this annex. For a concurrent assertion statement outside procedural code, which is continuously monitored, an instance of the equations in this annex exists for each starting clock event of the assertion.

The semantics is based on an abstract syntax for SystemVerilog assertions. There are several advantages to using the abstract syntax rather than the full SystemVerilog assertions BNF.

- a) The abstract syntax facilitates separation of derived operators from basic operators. The satisfaction relation is defined explicitly only for assertions built from basic operators.
- b) The abstract syntax avoids reliance on operator precedence, associativity, and auxiliary rules for resolving syntactic and semantic ambiguities.
- c) The abstract syntax simplifies the assertion language by modifying or eliminating some features that tend to encumber the definition of the formal semantics.
 - 1) The abstract syntax modifies local variable declarations so that they are integrated with sequence and property expressions. This change supports the rewriting algorithm (see below) that replaces each instance of a named sequence or property with a flattened sequence or property expression. The local variable declarations that appeared in the named sequence or property declaration, including local variable formal arguments, become part of the flattened expression. The abstract syntax also allows local variable declaration assignments. Local variable declaration assignments are eliminated by a rewriting procedure after sequence and property instances have been flattened (see [F.4.2](#)). The semantics of local variables does not explicitly refer to their types.

- 2) The abstract syntax eliminates instantiation of sequences and properties. The semantics of an assertion with an instance of a named sequence or nonrecursive property is the same as the semantics of a related assertion obtained by replacing the sequence or nonrecursive property instance with an explicitly written sequence or property expression. [F.4.1](#) defines a rewriting algorithm that replaces each instance of a named sequence or nonrecursive property with a flattened sequence or property expression. The semantics of an assertion that has one or more instances of recursive properties is defined in [F.7](#). The definition is in terms of an infinite set of associated assertions, each of which may have instances of sequences and nonrecursive properties, but has no instances of recursive properties. The semantics of each associated assertion is obtained, as before, by using the rewriting algorithm.
- 3) The abstract syntax does not allow implicit clocks. Clocking event controls must be applied explicitly in the abstract syntax.

In order to use this annex to determine the semantics of a SystemVerilog assertion, the assertion must first be transformed into an assertion in the abstract syntax. For assertions that do not involve recursive properties, this transformation involves eliminating sequence and nonrecursive property instances by using the rewriting algorithm (see [F.4.1](#)), eliminating local variable declaration assignments (see [F.4.2](#)), determining implicit or inferred clocking event controls, and eliminating redundant clocking event controls. For example, the following SystemVerilog assertion:

```
property P(logic[3:0] a, property q);
  (a[1:0] == 2'b10) ##1 (a[3:2] == 2'b01) |=> q;
endproperty

property Q(r, logic[1:2] d);
  logic[1:2] v;
  (1, v = d) ##1 r |=> d == v;
endproperty

always @(c) assert property ( P(A, Q(R, D)) );
```

is transformed into the assertion:

```
always @(c) assert property (
  (
    ( item(type(logic[3:0])'(A))[1:0] == 2'b10 ) ##1
    ( item(type(logic[3:0])'(A))[3:2] == 2'b01 ) |=>
    (
      logic[1:2] v;
      (1, v = item(type(logic[1:2])'(D))) ##1 item(type(R)'(R)) |=>
      item(type(logic[1:2])'(D)) == v
    )
  )
);
```

in the abstract syntax, assuming R is not a *variable_lvalue*.

F.3 Abstract syntax

F.3.1 Clock control

In this annex ([Annex F](#)) the clock controls are considered Boolean functions on the input alphabet, and in the $@_c$ notation c is assumed to be a Boolean. However, in SystemVerilog the notation $@_c$ is commonly used to designate a value-change sensitive event control. To describe how value-change sensitive event controls are

converted to Boolean, we introduce operator τ defining rewriting rules from an edge-sensitive clock control to a level-sensitive clock control. b, b_1, \dots denote a Boolean expression, and e, e_1, \dots denote an event expression.

In the following transformation it is assumed that all the clocking events occur at ticks of `$global_clock`.

- $\tau(\$global_clock) = 1$
- $\tau(b) = \$changing_gclk(b)$, for $b \neq \$global_clock$, see [14.14](#).
- $\tau(\text{posedge } b) = \$rising_gclk(b)$, see [F.3.4.4](#).
- $\tau(\text{negedge } b) = \$falling_gclk(b)$, see [F.3.4.4](#).
- $\tau(\text{edge } b) = \tau(\text{posedge } b) \ || \ \tau(\text{negedge } b)$.
- $\tau(e) = \$future_gclk(b)$, for a named event e (see [15.5](#)), and for a dummy bit variable b associated with the event e , such that b has value 1 in the time slots when the event e is triggered, and value 0 in all other time slots.
- $\tau(e \text{ iff } b) = \tau(e) \ \&\& \ b$
- $\tau(e_1 \text{ or } e_2) = \tau(e_1) \ || \ \tau(e_2)$
- $\tau(e_1, e_2) = \tau(e_1) \ || \ \tau(e_2)$

For example, the SystemVerilog event control `@(posedge clk)` corresponds to `@($rising_gclk(clk))` in the formal semantics description.

F.3.2 Abstract grammars

In the following abstract grammars, b denotes a Boolean expression, t denotes a type, v denotes a local variable name, and e denotes an expression.

The abstract grammar for unlocked sequences is as follows:

```

R ::= b                                // "Boolean expression" form
   | ( t v [ = e ]; R )                // "local variable declaration" form
   | ( 1, v = e )                      // "local variable sampling" form
   | ( R )                              // "parenthesis" form
   | ( R ##1 R )                        // "concatenation" form
   | ( R ##0 R )                        // "fusion" form
   | ( R or R )                          // "or" form
   | ( R intersect R )                  // "intersect" form
   | first_match ( R )                  // "first match" form
   | R [ *0 ]                            // "null repetition" form
   | R [ *1:$ ]                          // "unbounded repetition" form

```

The abstract grammar for clocked sequences is as follows:

```

S ::= @(b) R                            // "clock" form
   | ( t v [ = e ]; S )                // "local variable declaration" form
   | ( S )                              // "parenthesized" form
   | ( S ##1 S )                        // "concatenation" form

```

The abstract grammar for unlocked properties is as follows:

```

P ::= strong ( R )                      // "strong sequence" form
   | weak ( R )                          // "weak sequence" form
   | ( t v [ = e ]; P )                  // "local variable declaration" form
   | ( P )                              // "parenthesis" form
   | not P                               // "negation" form
   | ( P or P )                          // "or" form

```

```

| ( P and P )           // "and" form
| ( R |-> P )           // "implication" form
| nexttime P           // "nexttime" form
| ( P until P )       // "until" form
| accept_on ( b ) P // "abort" form

```

Each instance of *R* in this production shall be a nondegenerate unlocked sequence. In the “sequence” form, *R* shall not be tightly satisfied by the empty word. See [F.5.2](#) and [F.5.5](#) for the definitions of nondegeneracy and tight satisfaction.

The abstract grammar for clocked properties is as follows:

```

Q ::= @( b ) P           // "clock" form
| strong ( S )           // "strong sequence" form
| weak ( S )           // "weak sequence" form
| ( t v [ = e ]; Q )   // "local variable declaration" form
| ( Q )                 // "parenthesis" form
| not Q                 // "negation" form
| ( Q or Q )           // "or" form
| ( Q and Q )         // "and" form
| ( S |-> Q )           // "implication" form
| nexttime Q           // "nexttime" form
| ( Q until Q )       // "until" form
| accept_on ( b ) Q // "abort" form

```

Each instance of *S* in this production shall be a nondegenerate clocked sequence. In the “sequence” form, *S* shall not be tightly satisfied by the empty word. See [F.5.2](#) and [F.5.5](#) for the definitions of nondegeneracy and tight satisfaction.

The abstract grammar for unlocked top-level properties is as follows:

```

T ::= P                 // plain form
| disable iff ( b ) P // "disable" form
| ( t v [ = e ]; T ) // "local variable declaration" form
| ( T )                 // "parenthesis" form

```

The abstract grammar for clocked top-level properties is as follows:

```

U ::= Q                 // plain form
| disable iff ( b ) Q // "disable" form
| ( t v [ = e ]; U ) // "local variable declaration" form
| ( U )                 // "parenthesis" form

```

The abstract grammar for assertions is as follows:

```

A ::= always assert property ( U ) // "always" form
| always @( b ) assert property ( T ) // "always with clock" form
| initial assert property ( U ) // "initial" form
| initial @( b ) assert property ( T ) // "initial with clock" form

```

F.3.3 Notations

Except where specified otherwise, the following notational conventions, including subscripted versions of the notations, will be used throughout the remainder of this annex: *b* and *c* denote Boolean expressions; *t* denotes a type; *v* denotes a local variable name; *u* denotes a free checker variable name; *e* denotes an expression; uppercase *R* denotes an unlocked sequence; uppercase *S* denotes a clocked sequence; uppercase *P* denotes an unlocked property; uppercase *Q* denotes a clocked property; uppercase *T* denotes an unlocked

top-level property; uppercase U denotes a clocked top-level property; lowercase r and s denote sequences, either clocked or unclocked; lowercase p and q denote properties, either clocked or unclocked and either top-level or not; uppercase A denotes an assertion; $i, j, k, m,$ and n denote non-negative integer constants.

F.3.4 Derived forms

Internal parentheses are omitted in compositions of the (associative) operators **##1** and **or**.

F.3.4.1 Derived assertion statements

— **restrict property** \equiv **assume property**.

F.3.4.2 Derived sequence operators

F.3.4.2.1 Derived consecutive repetition operators

- Let $m > 0$. $R[*m] \equiv (R[*m-1] \text{ ##1 } R)$.
- $R[*0:\$] \equiv (R[*0] \text{ or } R[*1:\$])$.
- $R[*m:m] \equiv R[*m]$.
- Let $m < n$. $R[*m:n] \equiv (R[*m:n-1] \text{ or } R[*n])$.
- Let $m > 1$. $R[*m:\$] \equiv (R[*m-1] \text{ ##1 } R[*1:\$])$.
- $R[*] \equiv (R[*0] \text{ or } R[*1:\$])$.
- $R[+] \equiv (R[*1:\$])$.

F.3.4.2.2 Derived delay and concatenation operators

Let $m \leq n$.

- $(\text{##}[m:n] R) \equiv (1[*m:n] \text{ ##1 } R)$.
- $(\text{##}[m:\$] R) \equiv (1[*m:\$] \text{ ##1 } R)$.
- $(\text{##}m R) \equiv (1[*m] \text{ ##1 } R)$.
- $(\text{##}[*] R) \equiv (\text{##}[0:\$] R)$.
- $(\text{##}[+] R) \equiv (\text{##}[1:\$] R)$.
- Let $m > 0$. $(R_1 \text{ ##}[m:n] R_2) \equiv (R_1 \text{ ##1 } 1[*m-1:n-1] \text{ ##1 } R_2)$.
- Let $m > 0$. $(R_1 \text{ ##}[m:\$] R_2) \equiv (R_1 \text{ ##1 } 1[*m-1:\$] \text{ ##1 } R_2)$.
- Let $m > 1$. $(R_1 \text{ ##}m R_2) \equiv (R_1 \text{ ##1 } 1[*m-1] \text{ ##1 } R_2)$.
- $(R_1 \text{ ##}[0:0] R_2) \equiv (R_1 \text{ ##0 } R_2)$.
- Let $n > 0$. $(R_1 \text{ ##}[0:n] R_2) \equiv ((R_1 \text{ ##0 } R_2) \text{ or } (R_1 \text{ ##}[1:n] R_2))$.
- $(R_1 \text{ ##}[0:\$] R_2) \equiv ((R_1 \text{ ##0 } R_2) \text{ or } (R_1 \text{ ##}[1:\$] R_2))$.

F.3.4.2.3 Derived nonconsecutive repetition operators

Let $m \leq n$.

- $b[->m:n] \equiv (!b[*0:\$] \text{ ##1 } b)[*m:n]$.
- $b[->m:\$] \equiv (!b[*0:\$] \text{ ##1 } b)[*m:\$]$.
- $b[->m] \equiv (!b[*0:\$] \text{ ##1 } b)[*m]$.
- $b[=m:n] \equiv (b[->m:n] \text{ ##1 } !b[*0:\$])$.
- $b[=m:\$] \equiv (b[->m:\$] \text{ ##1 } !b[*0:\$])$.
- $b[=m] \equiv (b[->m] \text{ ##1 } !b[*0:\$])$.

F.3.4.2.4 Other derived operators

- $(R_1 \text{ and } R_2) \equiv ((R_1 \text{ \#\#1 } 1[*0:\$]) \text{ intersect } R_2) \text{ or } (R_1 \text{ intersect } (R_2 \text{ \#\#1 } 1[*0:\$]))$.
- $(R_1 \text{ within } R_2) \equiv ((1[*0:\$] \text{ \#\#1 } R_1 \text{ \#\#1 } 1[*0:\$]) \text{ intersect } R_2)$.
- $(b \text{ throughout } R) \equiv ((b [*0:\$]) \text{ intersect } R)$.
- $(R, v=e) \equiv (R \text{ \#\#0 } (1, v=e))$.
- $(R, v_1=e_1, \dots, v_k=e_k) \equiv ((R, v_1=e_1) \text{ \#\#0 } (1, v_2=e_2, \dots, v_k=e_k))$ for $k > 1$.

F.3.4.3 Derived property operators

F.3.4.3.1 Derived sequential property

- $R \equiv \text{strong}(R)$ when used in a **cover property** or **expect** statement. $R \equiv \text{weak}(R)$ when used in an **assert property** or **assume property** statement.

F.3.4.3.2 Derived Boolean operators

- $p_1 \text{ implies } p_2 \equiv (\text{not } p_1 \text{ or } p_2)$.
- $p_1 \text{ iff } p_2 \equiv ((p_1 \text{ implies } p_2) \text{ and } (p_2 \text{ implies } p_1))$.

F.3.4.3.3 Derived nonoverlapping implication operator

- $(R \mid \Rightarrow P) \equiv ((R \text{ \#\#1 } 1) \mid \rightarrow P)$.
- $(S \mid \Rightarrow Q) \equiv ((S \text{ \#\#1 } @ (1) 1) \mid \rightarrow Q)$.

F.3.4.3.4 Derived conditional operators

- $(\text{if}(b) P) \equiv (b \mid \rightarrow P)$.
- $(\text{if}(b) P_1 \text{ else } P_2) \equiv ((b \mid \rightarrow P_1) \text{ and } (\text{weak}(b) \text{ or } P_2))$.

F.3.4.3.5 Derived case operators

Let $\text{specify}(b)$ be a function that expands a Boolean expression b and treats it as signed or unsigned according to the rules mentioned in [12.5](#) for performing expression comparison while evaluating case statements.

- $(\text{case } (b) b_1: P_1 \text{ endcase}) \equiv (\text{if } (\text{specify}(b) === \text{specify}(b_1)) P_1)$.
- $(\text{case } (b) \text{ default: } P_d \text{ endcase}) \equiv (P_d)$.
- $(\text{case } (b) b_1: P_1 \text{ default: } P_d \text{ endcase}) \equiv (\text{if } (\text{specify}(b) === \text{specify}(b_1)) P_1 \text{ else } P_d)$.
- $(\text{case } (b) b_1: P_1 \dots b_n: P_n \text{ endcase}) \equiv (\text{if } (\text{specify}(b) === \text{specify}(b_1)) P_1 \text{ else case } (\text{specify}(b)) b_2: P_2 \dots b_n: P_n \text{ endcase})$.
- $(\text{case } (b) b_1: P_1 \dots b_n: P_n \text{ default: } P_d \text{ endcase}) \equiv (\text{if } (\text{specify}(b) === \text{specify}(b_1)) P_1 \text{ else case } (\text{specify}(b)) b_2: P_2 \dots b_n: P_n \text{ default: } P_d \text{ endcase})$.

F.3.4.3.6 Derived followed_by operators

- $(r \text{ \#\# } p) \equiv (\text{not}(r \mid \rightarrow \text{not } p))$.
- $(r \text{ \#\#} p) \equiv (\text{not}(r \mid \Rightarrow \text{not } p))$.

F.3.4.3.7 Derived abort operators

- $(\text{reject_on } (b) P) \equiv (\text{not } \text{accept_on } (b) \text{ not } P)$.
- $(\text{sync_accept_on } (b) P) \equiv (\text{accept_on } (b) P)$ when the clock context is 1.
- $(\text{sync_reject_on } (b) P) \equiv (\text{not } (\text{sync_accept_on } (b) \text{ not } P))$.

F.3.4.3.8 Derived unbounded temporal operators

- $(\text{always } p) \equiv (p \text{ until } 0)$.
- $(\text{s_eventually } p) \equiv (\text{not } (\text{always } (\text{not } p)))$.
- $(p \text{ s_until } q) \equiv ((p \text{ until } q) \text{ and s_eventually } q)$.
- $(p \text{ until_with } q) \equiv ((p \text{ until } (p \text{ and } q)))$.
- $(p \text{ s_until_with } q) \equiv ((p \text{ s_until } (p \text{ and } q)))$.

F.3.4.3.9 Derived bounded temporal operators

- $(\text{s_nexttime } p) \equiv (\text{not nexttime not } p)$.
- $(\text{nexttime}[0] p) \equiv (1 \text{ } \rightarrow p)$.
- Let $m > 0$. $(\text{nexttime}[m] p) \equiv (\text{nexttime}(\text{nexttime}[m-1] p))$.
- Let $m \geq 0$. $(\text{s_nexttime}[m] p) \equiv (\text{not nexttime}[m] \text{ not } p)$.
- Let $m \geq 0$. $(\text{eventually}[m:m] p) \equiv (\text{nexttime}[m] p)$;
- Let $m < n$. $(\text{eventually}[m:n] p) \equiv (\text{eventually}[m:n-1] p \text{ or nexttime}[n] p)$.
- Let $m \geq 0$. $(\text{always}[m:m] p) \equiv (\text{nexttime}[m] p)$.
- Let $m < n$. $(\text{always}[m:n] p) \equiv (\text{always}[m:n-1] p \text{ and nexttime}[n] p)$.
- Let $m \geq 0$. $(\text{always}[m:\$] p) \equiv (\text{nexttime}[m] \text{ always } p)$.
- Let $m \leq n$. $(\text{s_eventually}[m:n] p) \equiv (\text{not always}[m:n] \text{ not } p)$.
- Let $m \geq 0$. $(\text{s_eventually}[m:\$] p) \equiv (\text{s_nexttime}[m] \text{ s_eventually } p)$.
- Let $m \leq n$. $(\text{s_always}[m:n] p) \equiv (\text{not eventually}[m:n] \text{ not } p)$.

F.3.4.4 Derived sampled value functions

- $\$sampled(e) \equiv e$.
- $\$rose(e, c) \equiv \$past(b, 1, 1, c) \text{ } \neq 1 \text{ \&\& } b \text{ } \equiv 1$, where b is the LSB of e .
- $\$fell(e, c) \equiv \$past(b, 1, 1, c) \text{ } \neq 0 \text{ \&\& } b \text{ } \equiv 0$, where b is the LSB of e .
- $\$stable(e, c) \equiv \$past(e, 1, 1, c) \text{ } \equiv e$.
- $\$changed(e, c) \equiv \$past(e, 1, 1, c) \text{ } \neq e$.
- $\$rose_gclk(e) \equiv \$past_gclk(b) \text{ } \neq 1 \text{ \&\& } b \text{ } \equiv 1$, where b is the LSB of e .
- $\$fell_gclk(e) \equiv \$past_gclk(b) \text{ } \neq 0 \text{ \&\& } b \text{ } \equiv 0$, where b is the LSB of e .
- $\$stable_gclk(e) \equiv \$past_gclk(e) \text{ } \equiv e$.
- $\$changed_gclk(e) \equiv \$past_gclk(e) \text{ } \neq e$.
- $\$rising_gclk(e) \equiv b \text{ } \neq 1 \text{ \&\& } \$future_gclk(b) \text{ } \equiv 1$, where b is the LSB of e .
- $\$falling_gclk(e) \equiv b \text{ } \neq 0 \text{ \&\& } \$future_gclk(b) \text{ } \equiv 0$, where b is the LSB of e .
- $\$steady_gclk(e) \equiv e \text{ } \equiv \$future_gclk(e)$.
- $\$changing_gclk(e) \equiv e \text{ } \neq \$future_gclk(e)$.

F.3.4.5 Other derived operators

- $(t_1 v_1 [= e_1]; \dots; t_k v_k [= e_k]; X) \equiv (t_1 v_1 [= e_1]; (t_2 v_2 [= e_2]; \dots; t_k v_k [= e_k]; X))$
for $k > 1$ and X any of P, Q, R, S, T, U .

F.3.4.6 Checker variable assignment

- $\text{rand } tu = e \equiv \text{initial assume property } (@1 u \equiv e)$.
- $\text{always } @c u \leq e \equiv \text{always assume property } (@1 \$future_gclk(u) \equiv c ? e : u)$.

F.4 Rewriting algorithms

F.4.1 Rewriting sequence and property instances

This subclause describes an algorithm for rewriting a sequence or property that contains one or more instances of named sequences or nonrecursive properties. The result of the algorithm is one flattened sequence or property without instances. The semantics of a hierarchical sequence or property is defined to be the semantics of the flattened sequence or property resulting from the rewriting algorithm. The rewriting algorithm does not itself account for name resolution and assumes that names have been resolved prior to the substitution of actual arguments for references to the corresponding formal arguments. If the flattened sequence or property is not legal, then the source is not legal. A property rewritten in the algorithm may be the top-level property of a concurrent assertion.

For the rewriting algorithm, an auxiliary function *item* is defined as follows. The function *item* may be applied to any SystemVerilog expression that may appear as an actual argument expression in an instance of a named sequence or property. If *e* is such an expression, then *item(e)* behaves like *e* in all respects except that operations allowed on a reference to or instance of a named item declared with the same type as *e* are also allowed on *item(e)*. Also any operation that is allowed on an instance of a named sequence (respectively, property) is allowed on *item* applied to a sequence (respectively, property, including a top-level property).

The function *item* is not a SystemVerilog function, and it is introduced only in the rewriting algorithm. The rewriting algorithm uses *item* because operations that are legal on a reference to a formal argument within the body of a declaration might no longer be legal when an actual argument expression is substituted for the reference to the formal argument. For example, let *a* and *b* be variables of type `logic[0:1]`, let *v* be a variable of type `logic[0:3]`, and let *e* be the cast expression `type(logic[0:3])'({a,b})`. If *v* is a formal argument, then the part select expression `v[1:2]` is legal within the body of the declared item. However, if *e* is an actual argument expression passed to *v* in an instance, then the part select operation cannot be applied when *e* is substituted for *v* because `(type(logic[0:3])'({a,b})) [1:2]` is illegal. Using the *item* function, the form `item(type(logic[0:3])'({a,b})) [1:2]` is legal. For expressions with undefined type, *item* does not enable additional operations.

F.4.1.1 The rewriting algorithm

Given π a sequence or property, possibly a top-level property:

While there are property instances in π do:

begin

Select an arbitrary property instance *p* and replace it by `flatten_property(p)`.

end

While there are sequence instances in π do:

begin

- 1) Select an arbitrary sequence instance *r*.
- 2) If either (a) *r* appears as an *event_expression* in an *event_control* or a *clocking_event*, or (b) *r* is the operand in a *sequence_method_call*, then replace *r* by `item(sequence'flatten_sequence(r))`.
- 3) Otherwise, replace *r* by `flatten_sequence(r)`.

end

`flatten_property(p)`

begin

- 1) Create a copy *p'* of the declaration of *p*.

- 2) For each formal argument f of p' , let a_f be the corresponding actual argument expression for the instance p . I.e., a_f is the actual argument expression bound to f in p , or, if no argument is bound to f in p , then a_f is the default actual argument declared for f in p' .
- 3) For each untyped formal argument f of p' , do the following for each reference to f in p' :
 - a) If a_f is either \$ or a *variable_lvalue*, then replace the reference by a_f .
 - b) Otherwise, replace the reference by $item(\mathbf{type}(a_f) \ ' \ (a_f))$.
- 4) For each typed formal argument f of p' that is not a local variable formal argument and whose type t does not match (see [6.22.1](#)) **event**, **sequence**, or **property**, do the following for each reference to f in p' :
 - a) If t is a *casting_type* (see [6.24](#)), then replace the reference by $item(t'(a_f))$.
 - b) Otherwise, replace the reference by $item(\mathbf{type}(t)'(a_f))$.

According to [16.8.1](#), none of the references so replaced is the *variable_lvalue* in an *operator_assignment* or *inc_or_dec_expression* in a *sequence_match_item*.
- 5) For each typed formal argument f of p' whose type t matches (see [6.22.1](#)) **event**, **sequence**, or **property** (and therefore is not a local variable formal argument), do the following for each reference to f in p' :
 - a) If the reference stands as the *sequence_instance* in a *sequence_method_call*, then replace the reference by a_f .
 - b) Otherwise, replace the reference by (a_f) . The parentheses around a_f may be omitted if the reference is itself already enclosed in parentheses.
- 6) Determine a linear ordering of the local variable formal arguments of p' so that one local variable formal argument is guaranteed to precede a second local variable formal argument if the second local variable formal argument has a default actual argument that references the first local variable formal argument. According to [16.13.19](#), each local variable formal argument of a property is of direction **input**. For each local variable formal argument f of p' whose type is t , add to the beginning of the body of p' the local variable declaration " $t\ f = a_f$;" Arrange these local variable declarations to be in the linear order chosen above.
- 7) Return the expression obtained by copying the local variable declarations and body *property_spec* from p' and enclosing the result in parentheses.

end

flatten_sequence(r)

begin

- 1) Create a copy r' of the declaration of r .
- 2) For each formal argument f of r' , let a_f be the corresponding actual argument expression for the instance r . I.e., a_f is the actual argument expression bound to f in r , or, if no argument is bound to f in r , then a_f is the default actual argument declared for f in r' .
- 3) For each untyped formal argument f of r' , do the following for each reference to f in r' :
 - a) If a_f is either \$ or a *variable_lvalue*, then replace the reference by a_f .
 - b) Otherwise, replace the reference by $item(\mathbf{type}(a_f) \ ' \ (a_f))$.
- 4) For each typed formal argument f of r' that is not a local variable formal argument and whose type t does not match (see [6.22.1](#)) **event** or **sequence**, do the following for each reference to f in r' :
 - a) If t is a *casting_type* (see [6.24](#)), then replace the reference by $item(t'(a_f))$.
 - b) Otherwise, replace the reference by $item(\mathbf{type}(t)'(a_f))$.

According to [16.8.1](#), none of the references so replaced is the *variable_lvalue* in an *operator_assignment* or *inc_or_dec_expression* in a *sequence_match_item*.

- 5) For each typed formal argument f of r' whose type t matches (see 6.22.1) **event** or **sequence** (and therefore is not a local variable formal argument), do the following for each reference to f in r' :
 - a) If the reference stands as the *sequence_instance* in a *sequence_method_call*, then replace the reference by a_f .
 - b) Otherwise, replace the reference by (a_f) . The parentheses around a_f may be omitted if the reference is itself already enclosed in parentheses.
- 6) Determine a linear ordering of the local variable formal arguments of r' so that one local variable formal argument is guaranteed to precede a second local variable formal argument if the second local variable formal argument has a default actual argument that references the first local variable formal argument.
 - a) For each input local variable formal argument f of r' whose type is t , add to the beginning of the body of r' the local variable declaration " $t f = a_f$;"
 - b) For each inout local variable formal argument f of r' whose type is t , add to the beginning of the body of r' the local variable declaration " $t f = a_f$;" and include the assignment " $a_f = f$ " in a list of match items attached to the end of the body *sequence_expr* of r' .
 - c) For each output local variable formal argument f of r' whose type is t , add to the beginning of the body of r' the local variable declaration " $t f$;" and include the assignment " $a_f = f$ " in a list of match items attached to the end of the body *sequence_expr* of r' .

Arrange the local variable declarations added to the beginning of the body of r' to be in the linear order chosen above.
- 7) Return the expression obtained by copying the local variable declarations and body *sequence_expr* from r' and enclosing the result in parentheses.

end

According to 16.8.2, if f, f' are distinct local variable formal arguments of direction **inout** or **input**, then $a_f \neq a_{f'}$. Therefore, the overall result of the assignments to the actual arguments in 6(b) and 6(c) does not depend on the order of these assignments.

F.4.2 Rewriting local variable declaration assignments

After replacing instances of named sequences and properties as described in F.4.1, local variable declaration assignments are eliminated from the resulting sequences and properties. Corresponding local variable assignments are added within the sequences and properties using the procedure described below. Only after this step is completed are the clock rewrite rules used.

At several points, the procedure for rewriting local variable declaration assignments queries whether a sequence admits an empty match. The queries allow splitting of cases in order to avoid changing the empty match behavior. Formally, a sequence admits an empty match if and only if it is tightly satisfied by the empty word. The tight satisfaction relation is defined in F.5.2 and F.5.5, where it is assumed that the clock rewrite rules have already been applied to eliminate clocking operators. The current procedure requires that the clocking operators remain in the syntax. Therefore, an independent definition of admission of an empty match is given below by the function *admits_empty*, which maps sequences to $\{0, 1\}$. It can be proved that for a sequence r , $admits_empty(r) = 1$ if and only if the empty word tightly satisfies r' , where r' is the sequence that results from r by eliminating local variable declaration assignments and by applying the clock rewrite rules.

- $admits_empty(b) = 0$.
- $admits_empty((t \ v \ [= \ e \] ; \ r)) = admits_empty(r)$.
- $admits_empty((1, \ v \ = \ e)) = 0$.
- $admits_empty((\ r \)) = admits_empty(r)$.
- $admits_empty((r_1 \ \#\#1 \ r_2)) = admits_empty(r_1) \ \&\& \ admits_empty(r_2)$.

- $admits_empty(r_1 \ \#\#0 \ r_2) = 0$.
- $admits_empty(r_1 \ \mathbf{or} \ r_2) = admits_empty(r_1) \ || \ admits_empty(r_2)$.
- $admits_empty(r_1 \ \mathbf{intersect} \ r_2) = admits_empty(r_1) \ \&\& \ admits_empty(r_2)$.
- $admits_empty(\mathbf{first_match}(r)) = admits_empty(r)$.
- $admits_empty(r[*0]) = 1$.
- $admits_empty(r[*1:\$]) = admits_empty(r)$.
- $admits_empty(@ (c) r) = admits_empty(r)$.

Let r be a sequence, and let c be the unique semantic leading clock of r (semantic leading clocks are defined in 16.15.1). If $c = inherited$, then let $\kappa(r)$ be the empty string. Otherwise, let $\kappa(r) = @ (c)$.

The procedure first eliminates all local variable declaration assignments that are attached to sequences. In general, $(t \ v = e; r)$ is replaced by

$$(t \ v; \kappa(r) (((1, v = e) \ \#\#0 \ (r)) \ \mathbf{or} \ ((r) \ \mathbf{intersect} \ 1[*0])))$$

If $admits_empty(r) = 0$, then the replacement may be simplified to

$$(t \ v; \kappa(r) (((1, v = e) \ \#\#0 \ (r))))$$

If $admits_empty(r) = 1$, then the replacement may be simplified to

$$(t \ v; \kappa(r) (((1, v = e) \ \#\#0 \ (r)) \ \mathbf{or} \ 1[*0]))$$

After this step, local variable declaration assignments remain only attached to properties. So that the declaration assignments are executed after advancing to the alignment points with the appropriate semantic leading clocks, the procedure next pushes these assignments down in the syntax using the function *push* defined below. *push* takes a list of local variable declaration assignments as its first argument and a property as its second argument. The property may be a top-level property. For clarity of notation, concatenations of lists are enclosed in angle brackets (<, >), and the empty list is denoted by <>.

The procedure finishes by applying the function *push* with <> as first argument to each top-level property and descending recursively.

Let E denote an ordered list of local variable assignments. Other notations are as in [F.3.3](#).

- $push(E, (t \ v; p)) = (t \ v; push(E, p))$.
- $push(E, (t \ v = e; p)) = (t \ v; push(<E, v = e>, p))$.
- $push(<>, r) = r$. If E is non-empty, then

$$push(E, r) = \kappa(r) (1, E) \ \#\#0 \ (r)$$

In this case, r is a sequence used as a property. According to [16.13.22](#), $admits_empty(r) = 0$.
- $push(<>, r \ |-> p) = r \ |-> push(<>, p)$. If E is non-empty, then

$$push(E, r \ |-> p) = \kappa(r) (1, E) \ \#\#0 \ (r) \ |-> push(<>, p)$$
- $push(<>, r \ |=> p) = r \ |=> push(<>, p)$. If E is non-empty and $admits_empty(r) = 0$, then

$$push(E, r \ |=> p) = \kappa(r) (1, E) \ \#\#0 \ (r) \ |=> push(<>, p)$$

If E is non-empty and $admits_empty(r) = 1$, then

$$push(E, r \ |=> p) = (\kappa(r) (1, E) \ \#\#0 \ (r) \ |=> push(<>, p)) \ \mathbf{and} \ push(E, p)$$
- $push(<>, \mathbf{if}(b) \ p \ [\ \mathbf{else} \ q \]) = \mathbf{if}(b) \ push(<>, p) \ [\ \mathbf{else} \ push(<>, q) \]$. If E is non-empty, then

$$push(E, \mathbf{if}(b) \ p \ [\ \mathbf{else} \ q \]) = (1, E) \ |-> \mathbf{if}(b) \ push(<>, p) \ [\ \mathbf{else} \ push(<>, q) \]$$
.
- $push(E, \mathbf{disable \ iff}(b) \ p) = \mathbf{disable \ iff}(b) \ push(E, p)$.
- $push(E, @ (c) \ p) = @ (c) \ push(E, p)$.
- $push(E, (p)) = (push(E, p))$.
- $push(E, \mathbf{not} \ p) = \mathbf{not} \ push(E, p)$.

- $push(E, p \text{ or } q) = push(E, p) \text{ or } push(E, q)$.
- $push(E, p \text{ and } q) = push(E, p) \text{ and } push(E, q)$.

F.5 Semantics

Let \mathbf{P} be the set of atomic propositions.

The semantics of assertions and properties is defined via a relation of satisfaction by empty, finite, and infinite words over the alphabet $\Sigma = 2^{\mathbf{P}} \cup \{\top, \perp\}$. Such a word is an empty, finite, or infinite sequence of elements of Σ . The number of elements in the sequence is called the *length* of the word, and the length of word w is denoted $|w|$, where $|w|$ is either a non-negative integer or infinity.

The sequence elements of a word are called its *letters* and are assumed to be indexed consecutively beginning at zero. If $|w| > 0$, then the first letter of w is denoted w^0 ; if $|w| > 1$, then the second letter of w is denoted w^1 ; and so forth. $w^{i..}$ denotes the word obtained from w by deleting its first i letters. If $i < |w|$, then $w^{i..} = w^i w^{i+1} \dots$. If $i \geq |w|$, then $w^{i..}$ is empty.

If $i \leq j$, then $w^{i..j}$ denotes the finite word obtained from w by deleting its first i letters and also deleting all letters after its $(j + 1)$ st. If $i \leq j < |w|$, then $w^{i..j} = w^i w^{i+1} \dots w^j$.

If w is a word over Σ , define \bar{w} to be the word obtained from w by interchanging \top with \perp . More precisely, $\bar{w}^i = \top$ if $w^i = \perp$; $\bar{w}^i = \perp$ if $w^i = \top$; and $\bar{w}^i = w^i$ if w^i is an element in $2^{\mathbf{P}}$.

The semantics of clocked sequences and properties is defined in terms of the semantics of unlocked sequences and properties. See [F.5.1](#).

It is assumed that the satisfaction relation $\zeta \models b$ is defined for elements ζ in $2^{\mathbf{P}}$ and Boolean expressions b . For any Boolean expression b , define

$$\top \models b \quad \text{and} \quad \perp \not\models b.$$

F.5.1 Rewrite rules for clocks

The semantics of clocked sequences and properties is defined in terms of the semantics of unlocked sequences and properties. The following rewrite rules define the transformation of a clocked sequence or property into an unlocked version that is equivalent for the purposes of defining the satisfaction relation. In this transformation, it is required that the conditions in event controls not be dependent upon any local variables.

F.5.1.1 Rewrite rules for sequences

The transformation $T^S(S, c)$ recursively defined below produces a sequence R from a sequence S and a clock c :

- $T^S(b, c) = (!c[*0:\$] \#\#1 \ c \ \& \ b)$.
- $T^S((1, \ v = e), \ c) = (T^S(1, \ c) \#\#0 \ (1, \ v = e))$.
- $T^S((@ (c_2) \ r), \ c_1) = (T^S(r, \ c_2))$.
- $T^S((r_1 \#\#1 \ r_2), \ c) = (T^S(r_1, \ c) \#\#1 \ T^S(r_2, \ c))$.
- $T^S((r_1 \#\#0 \ r_2), \ c) = (T^S(r_1, \ c) \#\#0 \ T^S(r_2, \ c))$.
- $T^S((r_1 \ \text{or} \ r_2), \ c) = (T^S(r_1, \ c) \ \text{or} \ T^S(r_2, \ c))$.
- $T^S((r_1 \ \text{intersect} \ r_2), \ c) = (T^S(r_1, \ c) \ \text{intersect} \ T^S(r_2, \ c))$.

- $T^S(\mathbf{first_match}(r), c) = (\mathbf{first_match}(T^S(r, c)))$.
- $T^S((r[*0]), c) = (T^S(r, c)[*0])$.
- $T^S((r[*1:\$]), c) = (T^S(r, c)[*1:\$])$.

F.5.1.2 Rewrite rules for properties

The transformation $T^P(p, c)$ recursively defined below produces a property P from a property p and a clock c :

- $T^P(\mathbf{strong}(r), c) = (\mathbf{strong}(T^S(r, c)))$.
- $T^P(\mathbf{weak}(r), c) = (\mathbf{weak}(T^S(r, c)))$.
- $T^P((@ (c_2) p), c_1) = T^P(p, c_2)$.
- $T^P((\mathbf{disable_iff}(b) p), c) = (\mathbf{disable_iff}(b) T^P(p, c))$.
- $T^P((\mathbf{accept_on}(b) p), c) = (\mathbf{accept_on}(b) T^P(p, c))$.
- $T^P((\mathbf{sync_accept_on}(b) p), c) = (\mathbf{accept_on}(b \ \&\& \ c) T^P(p, c))$.
- $T^P((\mathbf{not} p), c) = (\mathbf{not} T^P(p, c))$.
- $T^P((r \mid\rightarrow p), c) = (T^S(r, c) \mid\rightarrow T^P(p, c))$.
- $T^P((p_1 \ \mathbf{or} \ p_2), c) = (T^P(p_1, c) \ \mathbf{or} \ T^P(p_2, c))$.
- $T^P((p_1 \ \mathbf{and} \ p_2), c) = (T^P(p_1, c) \ \mathbf{and} \ T^P(p_2, c))$.
- $T^P((\mathbf{nexttime} p), c) = (!c \ \mathbf{until} \ (c \ \mathbf{and} \ \mathbf{nexttime} \ (!c \ \mathbf{until} \ (c \ \mathbf{and} \ T^P(p, c))))$.
- $T^P((p_1 \ \mathbf{until} \ p_2), c) = ((\mathbf{not} \ (c \ \mathbf{and} \ \mathbf{not} \ T^P(p_1, c))) \ \mathbf{until} \ (c \ \mathbf{and} \ T^P(p_2, c)))$.

F.5.2 Tight satisfaction without local variables

Tight satisfaction is denoted by \models . For unlocked sequences without local variables, tight satisfaction is defined as follows: w, x, y , and z denote finite words over Σ .

- $w \models b$ iff $|w| = 1$ and $w^0 \models b$.
- $w \models (R)$ iff $w \models R$.
- $w \models (R_1 \ \#\#1 \ R_2)$ iff there exist x, y so that $w = xy$ and $x \models R_1$ and $y \models R_2$.
- $w \models (R_1 \ \#\#0 \ R_2)$ iff there exist x, y, z so that $w = xyz$ and $|y| = 1$, and $xy \models R_1$ and $yz \models R_2$.
- $w \models (R_1 \ \mathbf{or} \ R_2)$ iff either $w \models R_1$ or $w \models R_2$.
- $w \models (R_1 \ \mathbf{intersect} \ R_2)$ iff both $w \models R_1$ and $w \models R_2$.
- $w \models \mathbf{first_match}(R)$ iff both
 - $w \models R$ and
 - if there exist x, y so that $w = xy$ and $\bar{x} \models R$, then y is empty.
- $w \models R \ [*0]$ iff $|w| = 0$.
- $w \models R \ [*1:\$]$ iff there exist words w_1, w_2, \dots, w_j ($j \geq 1$) so that $w = w_1 w_2 \dots w_j$ and for every i so that $1 \leq i \leq j$, $w_i \models R$.

If S is a clocked sequence, then $w \models S$ iff $w \models S'$, where S' is the unlocked sequence that results from S by applying the rewrite rules.

An unlocked sequence R is nondegenerate iff there exists a nonempty finite word w over Σ so that $w \models R$. A clocked sequence S is nondegenerate iff the unlocked sequence S' that results from S by applying the rewrite rules is nondegenerate.

F.5.3 Satisfaction without local variables

F.5.3.1 Neutral satisfaction

w denotes a nonempty finite or infinite word over Σ . Assume that all properties, sequences, and unlocked property fragments do not involve local variables.

Neutral satisfaction of assertion statements is as follows:

For the definition of neutral satisfaction of assertion statements, b denotes the Boolean expression representing the enabling condition for the assertion statement. Intuitively, b is derived from the conditions causing a queued evaluation attempt of a procedural assertion statement (see [16.15.6](#)), while b is 1 for a declarative assertion statement.

- $w, b \models \mathbf{always} \ @ (c) \ \mathbf{assert} \ \mathbf{property} \ T$ iff for every $0 \leq i < |w|$ so that $\bar{w}^i \models c$ and $\bar{w}^i \models b$, either $w^{i..} \models @ (c) \ T$ or $w^{i..} \models^{\mathbf{d}} @ (c) \ T$.
- $w, b \models \mathbf{always} \ \mathbf{assert} \ \mathbf{property} \ U$ iff for every $0 \leq i < |w|$, if $\bar{w}^i \models b$ then either $w^{i..} \models U$ or $w^{i..} \models^{\mathbf{d}} U$.
- $w, b \models \mathbf{initial} \ @ (c) \ \mathbf{assert} \ \mathbf{property} \ T$ iff for every $0 \leq i < |w|$ so that $\bar{w}^{0..i} \models !c \ [*0:\$] \ \#\#1 \ c$ and $\bar{w}^i \models b$, either $w^{i..} \models @ (c) \ T$ or $w^{i..} \models^{\mathbf{d}} @ (c) \ T$.
- $w, b \models \mathbf{initial} \ \mathbf{assert} \ \mathbf{property} \ U$ iff (if $\bar{w}^0 \models b$ then either $w \models U$ or $w \models^{\mathbf{d}} U$).
- $w, b \models \mathbf{always} \ @ (c) \ \mathbf{assume} \ \mathbf{property} \ T$ iff $w; b \models \mathbf{always} \ @ (c) \ \mathbf{assert} \ \mathbf{property} \ T$.
- $w, b \models \mathbf{always} \ \mathbf{assume} \ \mathbf{property} \ U$ iff $w; b \models \mathbf{always} \ \mathbf{assert} \ \mathbf{property} \ U$.
- $w, b \models \mathbf{initial} \ @ (c) \ \mathbf{assume} \ \mathbf{property} \ T$ iff $w; b \models \mathbf{initial} \ @ (c) \ \mathbf{assert} \ \mathbf{property} \ T$.
- $w, b \models \mathbf{initial} \ \mathbf{assume} \ \mathbf{property} \ U$ iff $w; b \models \mathbf{initial} \ \mathbf{assert} \ \mathbf{property} \ U$.
- $w, b \models \mathbf{always} \ @ (c) \ \mathbf{cover} \ \mathbf{property} \ T$ iff there exists $0 \leq i < |w|$ so that $\bar{w}^i \models c$, $\bar{w}^i \models b$, and $w^{i..} \models @ (c) \ T$.
- $w, b \models \mathbf{always} \ \mathbf{cover} \ \mathbf{property} \ U$ iff there exists $0 \leq i < |w|$ so that $\bar{w}^i \models b$ and $w^{i..} \models U$.
- $w, b \models \mathbf{initial} \ @ (c) \ \mathbf{cover} \ \mathbf{property} \ T$ iff there exists $0 \leq i < |w|$ so that $\bar{w}^{0..i} \models !c \ [*0:\$] \ \#\#1 \ c$, $\bar{w}^i \models b$, and $w^{i..} \models @ (c) \ T$.
- $w, b \models \mathbf{initial} \ \mathbf{cover} \ \mathbf{property} \ U$ iff $\bar{w}^0 \models b$ and $w \models U$.

The neutral satisfaction of assertion statements defined above describes the behavior of an assertion statement on a single word. Given a set of words and a set of assumptions, the following definitions describe assertion statement satisfaction on the set of words predicated on the set of assumptions:

- A word in the set of words is *feasible* if every assumption in the set of assumptions is satisfied on the word.
- An **assert property** statement is *satisfied on a set of words predicated on the set of assumptions* if it is satisfied on each feasible word.
- A **cover property** statement is *satisfied on a set of words predicated on the set of assumptions* if it is satisfied on at least one feasible word.

An assertion statement *holds globally* on the set of words predicated on the set of assumptions if it is satisfied on every feasible word.

Neutral satisfaction of top-level properties is defined as follows:

- For $T = P$, $w \models T$ iff $w \models P$.
- For $U = Q$, $w \models U$ iff $w \models Q$.
- For $T = \mathbf{disable} \ \mathbf{iff} \ (b) \ P$, $w \models T$ iff either
 - $w \models P$ and no letter of w satisfies b , or

- Some letter of w satisfies b and $w^{0,i-1} \perp^\omega \models P$ for i the least index such that $w^i \models b$, $0 \leq i < |w|$.
- For $U = \mathbf{disable\ iff\ (b)\ } Q$, $w \models U$ iff either
 - $w \models Q$ and no letter of w satisfies b , or
 - Some letter of w satisfies b and $w^{0,i-1} \perp^\omega \models Q$ for i the least index such that $w^i \models b$, $0 \leq i < |w|$.
- $w \models (T)$ iff $w \models T$.
- $w \models (U)$ iff $w \models U$.

Disabling of top-level properties is defined as follows:

- For $T = P$, $w \not\models^d T$.
- For $U = Q$, $w \not\models^d U$.
- For $T = \mathbf{disable\ iff\ (b)\ } P$, $w \models^d T$ iff some letter of w satisfies b and both $w^{0,i-1} \top^\omega \models P$ and $w^{0,i-1} \perp^\omega \not\models P$ for i the least index such that $w^i \models b$, $0 \leq i < |w|$.
- For $U = \mathbf{disable\ iff\ (b)\ } Q$, $w \models^d U$ iff some letter of w satisfies b and both $w^{0,i-1} \top^\omega \models Q$ and $w^{0,i-1} \perp^\omega \not\models Q$ for i the least index such that $w^i \models b$, $0 \leq i < |w|$.
- $w \models^d (T)$ iff $w \models^d T$.
- $w \models^d (U)$ iff $w \models^d U$.

T is said to *pass* on w if $w \models T$. T is said to be *disabled* on w if $w \models^d T$. T is said to *fail* on w if T neither passes nor is disabled on w . It can be proved that T cannot both pass and be disabled on w .

Neutral satisfaction of properties is defined as follows:

- $w \models (P)$ iff $w \models P$.
- $w \models Q$ iff $w \models T^p(Q, 1)$.
- $w \models \mathbf{not\ } P$ iff $\bar{w} \not\models P$.
- $w \models \mathbf{strong\ (R)}$ iff there exists $0 \leq j < |w|$ so that $w^{0,j} \models R$.
- $w \models \mathbf{weak\ (R)}$ iff for every $0 \leq j < |w|$, $w^{0,j} \top^\omega \models \mathbf{strong\ (R)}$.
- $w \models (R \mid \rightarrow P)$ iff for every $0 \leq j < |w|$ so that $\bar{w}^{0,j} \models R$, $w^{j,\cdot} \models P$.
- $w \models (P_1 \mathbf{or\ } P_2)$ iff $w \models P_1$ or $w \models P_2$.
- $w \models (P_1 \mathbf{and\ } P_2)$ iff $w \models P_1$ and $w \models P_2$.
- $w \models (\mathbf{nexttime\ } P)$ iff either $|w| = 0$ or $w^{1,\cdot} \models P$.
- $w \models (P_1 \mathbf{until\ } P_2)$ iff either there exists $0 \leq j < |w|$ so that $w^{j,\cdot} \models P_2$ and for every $0 \leq i < j$, $w^{i,\cdot} \models P_1$, or for every $0 \leq i < |w|$, $w^{i,\cdot} \models P_1$.
- $w \models (\mathbf{accept_on\ (b)\ } P)$ iff either:
 - $w \models P$, or
 - For some $0 \leq i < |w|$, $w^i \models b$ and $w^{0,i-1} \top^\omega \models P$.
 Here, $w^{0,-1}$ denotes the empty word.

Remark: Because w is nonempty, it can be proved that $w \models \mathbf{not\ } b$ iff $w \models !b$.

F.5.3.2 Weak and strong satisfaction by finite words

This subclause defines weak and strong satisfaction, denoted \models^- and \models^+ (respectively) of an assertion A by a finite (possibly empty) word w over Σ . These relations are defined in terms of the relation of neutral satisfaction by infinite words as follows:

- $w \models^- A$ iff $w \top^\omega \models A$.
- $w \models^+ A$ iff $w \perp^\omega \models A$.

A tool checking for satisfaction of A by the finite word w should return the following:

- “Holds strongly” if $w \models^+ A$.
- “Fails” if $w \not\models^- A$.
- “Holds (but does not hold strongly)” if $w \models A$ and $w \not\models^+ A$.
- “Pending” if $w \models^- A$ and $w \not\models A$.

F.5.3.3 Vacuity

This subclause defines the relation of non-vacuity, denoted \models^{non} , between a word w and a property P . An evaluation of P on w is nonvacuous provided $w \models^{\text{non}} P$.

- Base:
 - $w \models^{\text{non}} \mathbf{strong}(R)$.
 - $w \models^{\text{non}} \mathbf{weak}(R)$.
- Induction:
 - $w \models^{\text{non}} (P)$ iff $w \models^{\text{non}} P$.
 - $w \models^{\text{non}} R \mid \rightarrow P$ iff there exists $i \geq 0$ such that $w^{0..i} \models R$ and $w^{i..} \models^{\text{non}} P$.
 - $w \models^{\text{non}} P_1 \mathbf{and} P_2$ iff $w \models^{\text{non}} P_1$ or $w \models^{\text{non}} P_2$.
 - $w \models^{\text{non}} P_1 \mathbf{or} P_2$ iff $w \models^{\text{non}} P_1$ or $w \models^{\text{non}} P_2$.
 - $w \models^{\text{non}} P_1 \mathbf{iff} P_2$ iff $w \models^{\text{non}} P_1$ or $w \models^{\text{non}} P_2$.
 - $w \models^{\text{non}} P_1 \mathbf{implies} P_2$ iff $w \models^{\text{non}} P_1$.
 - $w \models^{\text{non}} \mathbf{not} P$ iff $w \not\models^{\text{non}} P$.
 - $w \models^{\text{non}} \mathbf{nextime} P$ iff $|w| > 0$ and $w^{i..} \models^{\text{non}} P$.
 - $w \models^{\text{non}} P_1 \mathbf{until} P_2$ iff there exists $0 \leq i < |w|$ such that the following holds:
 - Either $w^{i..} \models^{\text{non}} P_1$ or $w^{i..} \models^{\text{non}} P_2$ and
 - For all $0 \leq j < i$, $w^{j..} \models P_1 \mathbf{and not} P_2$.
 - $w \models^{\text{non}} P_1 \mathbf{s_until} P_2$ iff there exists $0 \leq i < |w|$ such that the following holds:
 - Either $w^{i..} \models^{\text{non}} P_1$ or $w^{i..} \models^{\text{non}} P_2$ and
 - For all $0 \leq j < i$, $w^{j..} \models P_1 \mathbf{and not} P_2$.
 - $w \models^{\text{non}} \mathbf{always} P$ iff there exists $0 \leq i < |w|$ such that the following holds:
 - $w^{i..} \models^{\text{non}} P$ and
 - For all $0 \leq j < i$, $w^{j..} \models P$.
 - $w \models^{\text{non}} \mathbf{always} [m : n]P$ iff there exists $m \leq i \leq n$ such that the following holds:
 - $w^{i..} \models^{\text{non}} P$ and
 - For all $m \leq j < i$, $w^{j..} \models P$.
 - $w \models^{\text{non}} \mathbf{s_always} [m : n]P$ iff there exists $m \leq i \leq n$ such that the following holds:
 - $w^{i..} \models^{\text{non}} P$ and
 - For all $m \leq j < i$, $w^{j..} \models P$.
 - $w \models^{\text{non}} \mathbf{s_eventually} P$ iff there exists $0 \leq i < |w|$ such that the following holds:
 - $w^{i..} \models^{\text{non}} P$ and
 - For all $0 \leq j < i$, $w^{j..} \not\models P$.
 - $w \models^{\text{non}} \mathbf{eventually} [m : n]P$ iff there exists $m \leq i \leq n$ such that the following holds:
 - $w^{i..} \models^{\text{non}} P$ and
 - For all $m \leq j < i$, $w^{j..} \not\models P$.
 - $w \models^{\text{non}} \mathbf{s_eventually} [m : n]P$ iff there exists $m \leq i \leq n$ such that the following holds:
 - $w^{i..} \models^{\text{non}} P$ and

- For all $m \leq j < i$, $w^j \models \text{not } P$.
- $w \models^{\text{non}} \text{disable iff } (b) P$ iff $w \models^{\text{non}} P$ and one of the following holds:
 1. For every $0 \leq i < |w|$, $w^i \not\models b$.
 2. There exists a prefix x of w , such that for every $0 \leq i < |x|$, $x^i \not\models b$, and either $x \perp^{\omega} \models P$ or $x \top^{\omega} \not\models P$.
- $w \models^{\text{non}} \text{accept_on } (b) P$ iff $w \models^{\text{non}} P$ and one of the following holds:
 1. For every $0 \leq i < |w|$, $w^i \not\models b$.
 2. There exists a prefix x of w , such that for every $0 \leq i < |x|$, $x^i \not\models b$, and either $x \perp^{\omega} \models P$ or $x \top^{\omega} \not\models P$.
- $w \models^{\text{non}} \text{reject_on } (b) P$ iff $w \models^{\text{non}} P$ and one of the following holds:
 1. For every $0 \leq i < |w|$, $w^i \not\models b$.
 2. There exists a prefix x of w , such that for every $0 \leq i < |x|$, $x^i \not\models b$, and either $x \perp^{\omega} \models P$ or $x \top^{\omega} \not\models P$.

A word w satisfies property P nonvacuously iff $w \models P$ and $w \models^{\text{non}} P$.

The \models^{non} relation is not explicitly defined for all the derived operators. For these operators the \models^{non} relation is implicitly defined by unrolling their derivation.

F.5.4 Local variable flow

This subclause defines inductively how local variable names flow through unlocked sequences. Below, “ \cup ” denotes set union, “ \cap ” denotes set intersection, “ $-$ ” denotes set difference, and “ $\{\}$ ” denotes the empty set.

The function “*sample*” takes a sequence as input and returns a set of local variable names as output. Intuitively, this function returns the set of local variable names that are sampled (i.e., assigned) in the sequence.

The function “*block*” takes a sequence as input and returns a set of local variable names as output. Intuitively, this function returns the set of local variable names that are blocked from flowing out of the sequence.

The function “*flow*” takes a set X of local variable names and a sequence as input and returns a set of local variable names as output. Intuitively, this function returns the set of local variable names that flow out of the sequence given the set X of local variable names that flow into the sequence.

The function “*sample*” is defined by the following:

- $\text{sample}(b) = \{\}$.
- $\text{sample}((t \ v; \ R)) = \text{sample}(R) - \{v\}$.
- $\text{sample}((l, \ v = e)) = \{v\}$.
- $\text{sample}((R)) = \text{sample}(R)$.
- $\text{sample}((R_1 \ \#\#1 \ R_2)) = \text{sample}(R_1) \cup \text{sample}(R_2)$.
- $\text{sample}((R_1 \ \#\#0 \ R_2)) = \text{sample}(R_1) \cup \text{sample}(R_2)$.
- $\text{sample}((R_1 \ \text{or} \ R_2)) = \text{sample}(R_1) \cup \text{sample}(R_2)$.
- $\text{sample}((R_1 \ \text{intersect} \ R_2)) = \text{sample}(R_1) \cup \text{sample}(R_2)$.
- $\text{sample}(\text{first_match}(R)) = \text{sample}(R)$.
- $\text{sample}(R[*0]) = \{\}$.
- $\text{sample}(R[*1:\$]) = \text{sample}(R)$.

The function “*block*” is defined by the following:

- $block(b) = \{\}$.
- $block((t\ v; R)) = block(R) - \{v\}$.
- $block((1, v=e)) = \{\}$.
- $block((R)) = block(R)$.
- $block((R_1 \ \#\#1\ R_2)) = (block(R_1) - flow(\{\}, R_2)) \cup block(R_2)$.
- $block((R_1 \ \#\#0\ R_2)) = (block(R_1) - flow(\{\}, R_2)) \cup block(R_2)$.
- $block((R_1 \ \text{or}\ R_2)) = block(R_1) \cup block(R_2)$.
- $block((R_1 \ \text{intersect}\ R_2)) = block(R_1) \cup block(R_2) \cup (sample(R_1) \cap sample(R_2))$.
- $block(\text{first_match}(R)) = block(R)$.
- $block(R[*0]) = \{\}$.
- $block(R[*1:\$]) = block(R)$.

The function “*flow*” is defined by the following:

- $flow(X, b) = X$.
- $flow(X, (t\ v; R)) = (X \cap \{v\}) \cup flow(X - \{v\}, R) - \{v\}$.
- $flow(X, (1, v=e)) = X \cup \{v\}$.
- $flow(X, (R)) = flow(X, R)$.
- $flow(X, (R_1 \ \#\#1\ R_2)) = flow(flow(X, R_1), R_2)$.
- $flow(X, (R_1 \ \#\#0\ R_2)) = flow(flow(X, R_1), R_2)$.
- $flow(X, (R_1 \ \text{or}\ R_2)) = flow(X, R_1) \cap flow(X, R_2)$.
- $flow(X, (R_1 \ \text{intersect}\ R_2)) = (flow(X, R_1) \cup flow(X, R_2)) - block((R_1 \ \text{intersect}\ R_2))$.
- $flow(X, \text{first_match}(R)) = flow(X, R)$.
- $flow(X, R[*0]) = X$.
- $flow(X, R[*1:\$]) = flow(X, R)$.

Remark: It can be proved that $flow(X, R) = (X \cup flow(\{\}, R)) - block(R)$. It follows that $flow(\{\}, R)$ and $block(R)$ are disjoint. It can also be proved that $flow(\{\}, R)$ is a subset of $sample(R)$.

F.5.5 Tight satisfaction with local variables

A local variable context is a function that assigns values to local variable names. If L is a local variable context, then $\text{dom}(L)$ denotes the set of local variable names that are in the domain of L . If $D \subseteq \text{dom}(L)$, then $L|_D$ means the local variable context obtained from L by restricting its domain to D . If v is a local variable name, then $L \setminus v$ denotes $L|_{\text{dom}(L) - \{v\}}$ and $L[v]$ denotes $L|_{\{v\}}$.

In the presence of local variables, tight satisfaction is a four-way relation defining when a finite word w over the alphabet Σ together with an input local variable context L_0 satisfies an unlocked sequence R and yields an output local variable context L_1 . This relation is denoted as follows:

$$w, L_0, L_1 \equiv R.$$

and is defined below. It can be proved that the definition guarantees that $w, L_0, L_1 \equiv R$ implies $\text{dom}(L_1) = flow(\text{dom}(L_0), R)$.

- $w, L_0, L_1 \equiv (t\ v; R)$ iff there exists L such that $w, L_0 \setminus v, L \equiv R$ and $L_1 = L_0[v] \cup (L \setminus v)$.

- $w, L_0, L_1 \models (1, v = e)$ iff $|w| = 1$ and $w^0 \models 1$ and $L_1 = \{(v, e[L_0, w^0])\} \cup L_0 \setminus v$, where $e[L_0, w^0]$ denotes the value obtained from e by evaluating first according to L_0 and second according to w^0 . In case $w^0 \in \{\top, \perp\}$, $e[L_0, \top]$ and $e[L_0, \perp]$ can be any constant values of the type of e .
- $w, L_0, L_1 \models b$ iff $|w| = 1$ and $w^0 \models b[L_0]$ and $L_1 = L_0$. Here $b[L_0]$ denotes the expression obtained from b by substituting values from L_0 .
- $w, L_0, L_1 \models (R)$ iff $w, L_0, L_1 \models R$.
- $w, L_0, L_1 \models (R_1 \# \# 1 R_2)$ iff there exist x, y, L' so that $w = xy$ and $x, L_0, L' \models R_1$ and $y, L', L_1 \models R_2$.
- $w, L_0, L_1 \models (R_1 \# \# 0 R_2)$ iff there exist x, y, z, L' so that $w = xyz$ and $|y| = 1$, and $xy, L_0, L' \models R_1$ and $yz, L', L_1 \models R_2$.
- $w, L_0, L_1 \models (R_1 \text{ or } R_2)$ iff there exists L' so that both of the following hold:
 - Either $w, L_0, L' \models R_1$ or $w, L_0, L' \models R_2$, and
 - $L_1 = L'|_D$, where $D = \text{flow}(\text{dom}(L_0), (R_1 \text{ or } R_2))$.
- $w, L_0, L_1 \models (R_1 \text{ intersect } R_2)$ iff there exist L', L'' so that $w, L_0, L' \models R_1$ and $w, L_0, L'' \models R_2$ and $L_1 = L'|_D \cup L''|_{D'}$, where

$$D' = \text{flow}(\text{dom}(L_0), R_1) - (\text{block}((R_1 \text{ intersect } R_2)) \cup \text{sample}(R_2))$$

$$D'' = \text{flow}(\text{dom}(L_0), R_2) - (\text{block}((R_1 \text{ intersect } R_2)) \cup \text{sample}(R_1))$$

Remark: It can be proved that if $w, L_0, L' \models R_1$ and $w, L_0, L'' \models R_2$, then $L'|_D \cup L''|_{D'}$ is a function.

- $w, L_0, L_1 \models \text{first_match}(R)$ iff both
 - $w, L_0, L_1 \models R$ and
 - If there exist x, y, L' so that $w = xy$ and $\bar{x}, L_0, L' \models R$, then y is empty.
- $w, L_0, L_1 \models R[*0]$ iff $|w| = 0$ and $L_1 = L_0$.
- $w, L_0, L_1 \models R[*1;\$]$ iff there exist $L_{(0)} = L_0, w_1, L_{(1)}, w_2, L_{(2)}, \dots, w_j, L_{(j)} = L_1 (j \geq 1)$ so that $w = w_1 w_2 \dots w_j$ and for every i so that $1 \leq i \leq j$, $w_i, L_{(i-1)}, L_{(i)} \models R$.

If S is a clocked sequence, then $w, L_0, L_1 \models S$ iff $w, L_0, L_1 \models S'$, where S' is the unlocked sequence that results from S by applying the rewrite rules.

An unlocked sequence R is nondegenerate iff there exist a nonempty finite word w over Σ and local variable contexts L_0, L_1 so that $w, L_0, L_1 \models R$. A clocked sequence S is nondegenerate iff the unlocked sequence S' that results from S by applying the rewrite rules is nondegenerate.

F.5.6 Satisfaction with local variables

F.5.6.1 Neutral satisfaction

w denotes a nonempty finite or infinite word over Σ . L_0 and L_1 denote local variable contexts.

The rules defining neutral satisfaction of an assertion are identical to those without local variables, but with the understanding that the underlying properties can have local variables.

Neutral satisfaction of top-level properties is defined as follows:

- For $T = P$, $w, L_0 \models T$ iff $w, L_0 \models P$.
- For $U = Q$, $w, L_0 \models U$ iff $w, L_0 \models Q$.
- For $T = \text{disable iff}(b) P$, $w, L_0 \models T$ iff either
 - $w, L_0 \models P$ and no letter of w satisfies b , or
 - Some letter of w satisfies b and $w^{0, i-1} \perp^\omega, L_0 \models P$ for i the least index such that $w^i \models b$, $0 \leq i < |w|$.

- For $U = \mathbf{disable\ iff}(b) Q$, $w, L_0 \models U$ iff either
 - $w, L_0 \models Q$ and no letter of w satisfies b , or
 - Some letter of w satisfies b and $w^{0,i-1} \perp^\omega, L_0 \models Q$ for i the least index such that $w^i \models b$, $0 \leq i < |w|$.
- $w, L_0 \models (t \ v ; T)$ iff $w, L_0 \setminus v \models T$.
- $w, L_0 \models (t \ v ; U)$ iff $w, L_0 \setminus v \models U$.
- $w, L_0 \models (T)$ iff $w, L_0 \models T$.
- $w, L_0 \models (U)$ iff $w, L_0 \models U$.

Disabling of top-level properties is defined as follows:

- For $T = P$, $w, L_0 \not\models^{\mathbf{d}} T$.
- For $U = Q$, $w, L_0 \not\models^{\mathbf{d}} U$.
- For $T = \mathbf{disable\ iff}(b) P$, $w, L_0 \models^{\mathbf{d}} T$ iff some letter of w satisfies b and both $w^{0,i-1} \top^\omega, L_0 \models P$ and $w^{0,i-1} \perp^\omega, L_0 \not\models P$ for i the least index such that $w^i \models b$, $0 \leq i < |w|$.
- For $U = \mathbf{disable\ iff}(b) Q$, $w, L_0 \models^{\mathbf{d}} U$ iff some letter of w satisfies b and both $w^{0,i-1} \top^\omega, L_0 \models Q$ and $w^{0,i-1} \perp^\omega, L_0 \not\models Q$ for i the least index such that $w^i \models b$, $0 \leq i < |w|$.
- $w, L_0 \models^{\mathbf{d}} (t \ v ; T)$ iff $w, L_0 \setminus v \models^{\mathbf{d}} T$.
- $w, L_0 \models^{\mathbf{d}} (t \ v ; U)$ iff $w, L_0 \setminus v \models^{\mathbf{d}} U$.
- $w, L_0 \models^{\mathbf{d}} (T)$ iff $w, L_0 \models^{\mathbf{d}} T$.
- $w, L_0 \models^{\mathbf{d}} (U)$ iff $w, L_0 \models^{\mathbf{d}} U$.

T is said to *pass* on w, L_0 if $w, L_0 \models T$. T is said to be *disabled* on w, L_0 if $w, L_0 \models^{\mathbf{d}} T$. T is said to *fail* on w, L_0 if T neither passes nor is disabled on w, L_0 . It can be proved that T cannot both pass and be disabled on w, L_0 .

Neutral satisfaction of properties is defined as follows:

- $w \models Q$ iff $w, \{\} \models Q$.
- $w, L_0 \models Q$ iff $w, L_0 \models T^P(Q, 1)$.
- $w, L_0 \models (t \ v ; P)$ iff $w, L_0 \setminus v \models^{\mathbf{d}} P$.
- $w, L_0 \models \mathbf{not} P$ iff $\overline{w}, L_0 \not\models P$.
- $w, L_0 \models \mathbf{strong}(R)$ iff there exist $0 \leq j < |w|$ and L_1 so that $w^{0,j}, L_0, L_1 \models R$.
- $w, L_0 \models \mathbf{weak}(R)$ iff for every $0 \leq j < |w|$, $w^{0,j} \top^\omega, L_0 \models \mathbf{strong}(R)$.
- $w, L_0 \models (R \ \mid\rightarrow\ P)$ iff for every $0 \leq j < |w|$ and L_1 so that $\overline{w}^{0,j}, L_0, L_1 \models R$, $w^{j,\cdot}, L_1 \models P$.
- $w, L_0 \models (P)$ iff $w, L_0 \models P$.
- $w, L_0 \models (P_1 \ \mathbf{or} \ P_2)$ iff $w, L_0 \models P_1$ or $w, L_0 \models P_2$.
- $w, L_0 \models (P_1 \ \mathbf{and} \ P_2)$ iff $w, L_0 \models P_1$ and $w, L_0 \models P_2$.
- $w, L_0 \models (\mathbf{nexttime} P)$ iff either $|w| = 0$ or $w^{1,\cdot}, L_0 \models P$.
- $w, L_0 \models (P_1 \ \mathbf{until} \ P_2)$ iff either there exists $0 \leq j < |w|$ so that $w^{j,\cdot}, L_0 \models P_2$ and for every $0 \leq i < j$, $w^{i,\cdot}, L_0 \models P_1$, or for every $0 \leq i < |w|$, $w^{i,\cdot}, L_0 \models P_1$.
- $w, L_0 \models (\mathbf{accept_on}(b) P)$ iff either:
 - $w, L_0 \models P$ and no letter of w satisfies b , or
 - For some $0 \leq i < |w|$, $w^i \models b$ and $w^{0,i-1} \top^\omega \models P$. Here, $w^{0,-1}$ denotes the empty word.

F.5.6.2 Weak and strong satisfaction by finite words

The definition is identical to that without local variables, but with the understanding that the underlying properties can have local variables.

F.5.6.3 Vacuity

The definition is identical to that without local variables (see [F.5.3.3](#)), but with the understanding that the underlying properties can have local variables and that $w, L_0 \models^{\text{non}} (t \ v ; P)$ iff $w, L_0 \setminus v \models^{\text{non}} P$.

F.6 Extended expressions

This subclause describes the semantics of several constructs that are used like expressions, but whose meaning at a point in a word may depend both on the letter at that point and on other letters in the word. By abuse of notation, the meanings of these extended expressions are defined for letters denoted “ w^j ” even though they depend also on letters w^i for $i \neq j$. The reason for this abuse is to make clear the way these definitions should be used in combination with those in preceding subclauses.

F.6.1 Extended Booleans

w denotes a nonempty finite or infinite word over Σ , j denotes an integer so that $0 \leq j < |w|$, and $T(V)$ denotes an instance of a clocked or unclocked sequence that is passed the local variables V as actual arguments.

- $w^j, L_0, L_1 \models T(V). \text{triggered}$ iff there exist $0 \leq i \leq j$ and L so that both $w^{i,j}, \{\}, L \models T(V)$ and $L_1 = L_0 \upharpoonright_D \cup L_V$, where $D = \text{dom}(L_0) - (\text{dom}(L) \cap V)$.
- $w^j, L_0, L_1 \models @ (c) (T(V). \text{matched})$ iff there exists $0 \leq i < j$ so that $w^i, L_0, L_1 \models T(V). \text{triggered}$ and $w^{i+1,j}, \{\}, \{\} \models c [->1]$.

F.6.2 Past

w denotes a nonempty finite or infinite word over Σ , and j denotes an integer so that $0 \leq j < |w|$.

- Let $n \geq 1$. If there exist $0 \leq i < j$ so that $w^{i,j}, \{\}, \{\} \models ((c \ \&\& \ e_2) \ \#\#1 \ (c \ \&\& \ e_2 [=n-1] \ \#\#1 \ 1))$, then $\$ \text{past}(e_1, n, e_2, c) [w^j] = e_1 [w^i]$. Otherwise, $\$ \text{past}(e_1, n, e_2, c) [w^j]$ is the result of evaluating the expression e_1 using the initial values of the variables comprising the expression. The initial value of a static variable is the value assigned in its declaration, or, in the absence of such an assignment, it is the default (or uninitialized) value of the corresponding type (see [6.8, Table 6-7](#)). The initial value of any other variable or signal is the default value of the corresponding type (see [6.8, Table 6-7](#)).
- If $j < 0$ then $\$ \text{past_gclk}(e) [w^j] = e [w^{j-1}]$. $\$ \text{past_gclk}(e) [w^0]$ is the result of evaluating the expression e using the initial values of the variables comprising the expression.

NOTE— $\$ \text{past}(e)$ is equivalent to $\$ \text{past}(e, 1, 1'b1, 1'b1)$.

F.6.3 Future

w denotes a nonempty finite or infinite word over Σ , and j denotes an integer so that $0 \leq j < |w| - 1$. $\$ \text{future_gclk}(e) [w^j] = e [w^{j+1}]$. If w is a finite word, $\$ \text{future_gclk}(e) [w^{|w|-1}]$ is undefined.

F.7 Recursive properties

This subclause defines the neutral semantics of properties, including top-level properties, with instances of recursive properties in terms of the neutral semantics of properties with instances of nonrecursive properties. The latter can be expanded to properties in the abstract syntax by applying the rewriting algorithm (see [F.4.1](#)); therefore, their semantics is assumed to be understood.

Below are precise versions of the four restrictions given in [16.13.17](#) and the precise definition of recursive property. The dependency digraph is the directed graph $\langle V, E \rangle$, where V is the set of all named properties and an order pair (p, q) is in E if, and only if, an instance of named property q appears in the declaration of named property p . For example, for the set of properties

```

property p1 (v) ;
  v | => p2 (p3 ());
endproperty

property p2 (v) ;
  a or (1'b1 | => v);
endproperty

property p3;
  p1 (a && b);
endproperty

```

the dependency digraph is

$\langle \{p1, p2, p3\}, \{(p1,p2),(p1,p3),(p3,p1)\} \rangle$

A named property is recursive if it is in a nontrivial, strongly connected component of the dependency digraph. An instance of named property q is recursive if it is in the declaration of a named property p so that p and q are in the same nontrivial, strongly connected component of the dependency digraph. Here, p and q need not be distinct properties. Define the weight of an instance of q in the declaration of p as the minimal number of time steps that are guaranteed from the beginning of the declaration of p until the instance of q . In the example above, the weights of $p2(p3())$ and of $p3()$ in $p1$ are both one. Define the weight of an edge (p, q) in the dependency digraph as the minimal weight among the weights of instances of q in the declaration of p .

The following are the restrictions over recursive properties:

- RESTRICTION 1: The negation operator **not** cannot be applied to any property expression that instantiates a property from which a recursive property can be reached in the dependency digraph.
- RESTRICTION 2: The operator **disable iff** cannot be used in the declaration of a recursive property.
- RESTRICTION 3: In every cycle of the dependency digraph, the sum of the weights of the edges shall be positive.
- RESTRICTION 4: For every recursive instance of q in the declaration of p , each actual argument expression e of the instance satisfies one of the following conditions:
 - e is itself a formal argument of p .
 - No formal argument of p appears in e .

Let p be a named property. For $k \geq 0$, the k -fold approximation to p , denoted $p[k]$, is a named property without instances of recursive properties defined inductively as follows:

- The declaration of $p[0]$ is obtained from the declaration of p by replacing the body *property_spec* the literal `1'b1`.
- For $k > 0$, the declaration of $p[k]$ is obtained from the declaration of p by replacing each instance of a recursive property by the corresponding instance of its $(k - 1)$ -fold approximation and by replacing each instance of a nonrecursive property by the corresponding instance of its k -fold approximation.

Let π be a property, possibly the top-level property of a concurrent assertion. The k -fold approximation to π , denoted $\pi[k]$, is obtained from π by replacing each instance of a named property by the corresponding instance of its k -fold approximation. The semantics of π is then defined as follows: for any word w over Σ and local variable context L , $w, L \models \pi$ iff for all $k > 0$, $w, L \models \pi[k]$. Since $\pi[k]$ does not have instances of recursive properties, its semantics is obtained using the rewriting algorithm (see [F.4.1](#)).

Annex G

(normative)

Std package

G.1 General

This annex describes the contents of the built-in standard package, including the following:

- The semaphore class
- The mailbox class
- The randomize function
- The process class

G.2 Overview

The standard package contains system types (see [26.7](#)). The following types are provided by the std built-in package. The descriptions of the semantics of these types are defined in the indicated subclauses.

G.3 Semaphore

The semaphore class is described in [15.3](#), and its prototype is as follows:

```
class semaphore;  
    function new(int keyCount = 0);  
    function void put(int keyCount = 1);  
    task get(int keyCount = 1);  
    function int try_get(int keyCount = 1);  
endclass
```

G.4 Mailbox

The mailbox class is described in [15.4](#), and its prototype is as follows:

The *dynamic_singular_type* below represents a special type that enables run-time type checking.

```
class mailbox #(type T = dynamic_singular_type) ;  
    function new(int bound = 0);  
    function int num();  
    task put( T message);  
    function int try_put( T message);  
    task get( ref T message );  
    function int try_get( ref T message );  
    task peek( ref T message );  
    function int try_peek( ref T message );  
endclass
```

G.5 Randomize

The randomize function is described in [18.12](#), and its prototype is as follows:

```
function int randomize( ... );
```

The syntax for the randomize function is defined as randomize_call in [A.8.2](#). The specific form applicable to std::randomize is summarized here:

```
randomize { attribute_instance } [ ( [ variable_identifier_list ] ) ]  
[ with constraint_block ]
```

G.6 Process

The process class is described in [9.7](#), and its prototype is as follows:

```
class process;  
    enum state { FINISHED, RUNNING, WAITING, SUSPENDED, KILLED };  
  
    static function process self();  
    function state status();  
    function void kill();  
    task await();  
    function void suspend();  
    function void resume();  
endclass
```

Annex H

(normative)

DPI C layer

H.1 General

This annex describes the foreign language side of the direct programming interface.

H.2 Overview

The SystemVerilog DPI allows direct inter-language function calls between SystemVerilog and any foreign programming language with a C function call protocol and linking model:

- Functions implemented in C and given import declarations in SystemVerilog can be called from SystemVerilog; such functions are referred to as *imported functions*.
- Functions implemented in SystemVerilog and specified in export declarations can be called from C; such functions are referred to as *exported functions*.
- Tasks implemented in SystemVerilog and specified in export declarations can be called from C; such functions are referred to as *exported tasks*.
- Functions implemented in C that can be called from SystemVerilog and can in turn call exported tasks; such functions are referred to as *imported tasks*.

The SystemVerilog DPI supports only SystemVerilog data types, which are the sole data types that can cross the boundary between SystemVerilog and a foreign language in either direction. On the other hand, the data types used in C code shall be C types; hence, the duality of types.

A value that is passed through the DPI is specified in SystemVerilog code as a value of SystemVerilog type, while the same value shall be specified in C code as a value of C type. Therefore, a pair of matching type definitions is required to pass a value through DPI: the SystemVerilog definition and the C definition.

It is the user's responsibility to provide these matching definitions. A tool (such as a SystemVerilog compiler) can facilitate this by generating C type definitions for the SystemVerilog definitions used in DPI for imported and exported functions.

Some SystemVerilog types are directly compatible with C types; defining a matching C type for them is straightforward. There are, however, SystemVerilog-specific types, namely packed types (arrays, structures, and unions), 2-state or 4-state, which have no natural correspondence in C. DPI defines a canonical representation of 4-state types that is exactly the same as the representation used by the VPI's *avalue/bvalue* representation of 4-state vectors. DPI defines a 2-state representation model that is consistent with the VPI 4-state model. DPI defines library functions to assist users in working with the canonical data representation.

The DPI C interface includes deprecated functions and definitions related to implementation-specific representation of packed array arguments. These functions are enabled by using the "DPI" specification string in import and export declarations (see [35.5](#)). Refer to [H.13](#) for details on the deprecated functionality.

Formal arguments in SystemVerilog can be specified as open arrays solely in import declarations; exported SystemVerilog subroutines cannot have formal arguments specified as open arrays. A formal argument is an open array when a range of one or more of its dimensions is unspecified (denoted in SystemVerilog by using

empty square brackets, []). This corresponds to a relaxation of the DPI argument-matching rules (see [35.5.6.1](#)). Actual arguments' packed dimensions shall collectively match a solitary, unsized formal packed dimension. Similarly, any actual unpacked dimension shall match a corresponding formal argument dimension that is unsized. This facilitates writing generalized C code that can handle SystemVerilog arrays of different sizes.

The C layer of DPI typically uses normalized ranges. The term *normalized ranges* means $[n-1:0]$ indexing for the packed part (which may involve linearizing multiple packed dimensions) and means $[0:n-1]$ indexing for an unpacked dimension. Normalized ranges are used for the canonical representation of packed arrays in C and for SystemVerilog arrays passed as actual arguments to C. Standard open array query functions (see [H.12.2](#)) return the original, SystemVerilog ranges for unpacked dimensions and return a linearized, normalized range for the packed dimension.

Function arguments are generally passed by some form of reference or by value. All formal arguments, except open arrays, are passed by direct reference or value, and, therefore, are directly accessible in C code. Only small values of SystemVerilog input arguments (see [H.8.7](#)) are passed by value. Formal arguments declared in SystemVerilog as open arrays are passed by a handle (type `svOpenArrayHandle`) and are accessible via library functions. Array-querying functions are provided for open arrays.

The C layer of DPI defines a portable binary interface. Once DPI C code is compiled into object code, the resulting object code shall work without recompilation in any compliant SystemVerilog implementation.

One normative include file, `svdpi.h`, is provided as part of the DPI C layer. This file defines all basic types, the canonical 2-state and 4-state data representation, and all interface functions.

H.3 Naming conventions

All names introduced by this interface shall conform to the following conventions:

- All names defined in this interface are prefixed with `sv` or `SV_`.
- Function and type names start with `sv`, followed by initially capitalized words with no separators, e.g., `svLogicVecVal`.
- Names of symbolic constants start with `sv_`, e.g., `sv_x`.
- Names of macro definitions start with `SV_`, followed by all uppercase words separated by an underscore (`_`), e.g., `SV_GET_UNSIGNED_BITS`.

H.4 Portability

DPI applications are always portable at the binary level. When compiled on a given platform, DPI object code shall work with every SystemVerilog simulator on that platform.

H.5 `svdpi.h` include file

The C layer of the DPI defines include file `svdpi.h`.

Applications that use the DPI with C code usually need this main include file. The include file `svdpi.h` defines the types for canonical representation of 2-state (`bit`) and 4-state (`logic`) values and passing references to SystemVerilog data objects. The file also provides function headers and defines a number of helper macros and constants.

The `svdpi.h` file is fully defined in [Annex I](#). The content of `svdpi.h` does not depend on any particular implementation; all simulators shall use the same file. For more details on `svdpi.h`, see [H.10.1](#) and [Annex I](#).

This file may also contain the deprecated functions and data representations described in [H.13](#). [H.13](#) also describes the deprecated header `svdpi_src.h`, which defines the implementation-dependent representation of packed values.

H.6 Semantic constraints

NOTE—Constraints expressed here merely restate those expressed in [35.5.1](#).

Formal and actual arguments of both imported subroutines and exported subroutines are bound by the WYSIWYG principle: What You Specify Is What You Get. This principle is binding both for the caller and for the callee, in C code and in SystemVerilog code. For the callee, it guarantees the actual arguments are as specified for the formal ones. For the caller, it means the function call arguments shall conform with the types of the formal arguments, which might require type-coercion on the caller side.

Another way to state this is that no compiler (either C or SystemVerilog) can make argument coercions between a caller's declared formals and the callee's declared formals. This is because the callee's formal arguments are declared in a different language from the caller's formal arguments; hence there is no visible relationship between the two sets of formals. Users are expected to understand all argument relationships and provide properly matched types on both sides of the interface (see [H.7.2](#)).

In SystemVerilog code, the compiler can change the formal arguments of a native SystemVerilog subroutine and modify its code accordingly because of optimizations, compiler pragmas, or command line switches. The situation is different for imported tasks and functions. A SystemVerilog compiler cannot modify the C code, perform any coercions, or make any changes whatsoever to the formal arguments of an imported subroutine.

A SystemVerilog compiler shall provide any necessary coercions for the actual arguments of every imported subroutine call. For example, a SystemVerilog compiler might truncate or extend bits of a packed array if the widths of the actual and formal arguments are different.

Similarly, a C compiler can provide coercion for C types based on the relationship of the arguments in an exported subroutine's C prototype (formals) and the exported subroutine's C call site (actuals). However, a C compiler cannot provide such coercion for SystemVerilog types.

Coercion can be necessary when a SystemVerilog actual argument's data type is ordinarily accepted by DPI ([H.7.4](#)) and the argument is modified by an optional qualifier (such as `rand`), which has semantics unrelated to the type's representation. If a SystemVerilog compiler associates extra bits with such a data type, it shall coerce an actual argument of that type to match the unqualified SystemVerilog form that lacks such bits. When such a qualifier is associated with a DPI import function's formal arguments the DPI interface shall not implement the qualifier's semantics, shall expect the unqualified form of the type from SystemVerilog and shall deliver data for that type in the unqualified form back to SystemVerilog without manipulating any extra bits associated with the qualified form.

For an inter-language function call between SystemVerilog and C in either direction, the compilers expect, but cannot enforce, that the types on either side are compatible. Each compiler can coerce data to an expected form for its side of the inter-language boundary. However, the imported or exported function types must match the types of the corresponding subroutines in the foreign language, ignoring the presence of the kind of qualifiers described above.

H.6.1 Types of formal arguments

The WYSIWYG principle verifies the types of formal arguments of imported functions: an actual argument is required to be of the type specified for the formal argument, with the exception of open arrays (for which unspecified ranges are statically unknown). Formal arguments, other than open arrays, are fully defined by imported declaration; they shall have ranges of packed or unpacked arrays exactly as specified in the imported declaration. Only the SystemVerilog declaration site of the imported function is relevant for such formal arguments.

Formal arguments defined as open arrays in the C layer are passed by handle (see [H.12](#)). Their unpacked dimensions match those of the corresponding actual argument, while their packed dimension is a linearized, normalized version of all the actual argument's packed dimensions. The unsized ranges of open arrays are determined at a call site; the rest of the type information is specified at the import declaration. See also [H.7.1](#).

Therefore, if a formal argument is declared as `bit [15:8] b []`, then the import declaration specifies that the formal argument is an unpacked array of packed bit array with bounds 15 to 8, while the actual argument used at a particular call site defines the bounds for the unpacked part for that call.

H.6.2 Input arguments

Formal arguments specified in SystemVerilog as `input` shall not be modified by the foreign language code. See also [35.5.1.2](#).

H.6.3 Output arguments

The initial values of formal arguments specified in SystemVerilog as `output` are undetermined and implementation dependent. See also [35.5.1.2](#).

H.6.4 Value changes for output and inout arguments

The SystemVerilog simulator is responsible for handling value changes for `output` and `inout` arguments. Such changes shall be detected and handled after the control returns from C code to SystemVerilog code.

H.6.5 Context and noncontext tasks and functions

Also refer to [35.5.3](#).

Some DPI imported subroutines or other interface functions called from them require that the context of their call be known. It takes special instrumentation of their call instances to provide such context; for example, a variable referring to the "current instance" might need to be set. To avoid any unnecessary overhead, imported tasks and function calls in SystemVerilog code are not instrumented unless the imported tasks or function is specified as context in its SystemVerilog import declaration.

The SystemVerilog context of DPI export subroutines must be known when they are called by SystemVerilog subroutines, or they are called by DPI imports. When an import invokes the `svSetScope` utility prior to calling the export, it sets the context explicitly. Otherwise, the context will be the context of the instantiated scope where the import declaration is located. Because imports with diverse instantiated scopes can export the same subroutine, multiple instances of such an export can exist after elaboration. Prior to any invocations of `svSetScope`, these export instances would have different contexts, which would reflect their imported caller's instantiated scope.

For the sake of simulation performance, a noncontext imported subroutine call shall not block SystemVerilog compiler optimizations. An imported subroutine not specified as context shall not access any data objects from SystemVerilog other than its actual arguments. Only the actual arguments can be affected (read or written) by its call. Therefore, a call of noncontext imported subroutine is not a barrier for optimizations. A context imported subroutine, however, can access (read or write) any SystemVerilog data objects by calling VPI or by calling an embedded export subroutine. Therefore, a call to a context subroutine is a barrier for SystemVerilog compiler optimizations.

Only the calls of context imported tasks and functions are properly instrumented and cause conservative optimizations; therefore, only those tasks and functions can safely call all functions from other APIs, including VPI functions or exported SystemVerilog functions. For imported subroutines not specified as context, the effects of calling VPI or SystemVerilog functions can be unpredictable; and such calls can crash if the callee requires a context that has not been properly set.

Special DPI utility functions exist that allow imported subroutines to retrieve and operate on their context. For example, the C implementation of an imported subroutine can use `svGetScope()` to retrieve an `svScope` corresponding to the instance scope of its corresponding SystemVerilog import declaration. See [H.9](#) for more details.

H.6.6 Pure functions

See also [35.5.2](#).

Only nonvoid functions with no **output** or **inout** arguments can be specified as **pure**. Functions specified as **pure** in their corresponding SystemVerilog import declarations shall have no side effects; their results need to depend solely on the values of their input arguments. Calls to such functions can be removed by SystemVerilog compiler optimizations or replaced with the values previously computed for the same values of the input arguments.

Specifically, a **pure** function is assumed not to directly or indirectly (i.e., by calling other functions) perform the following:

- Perform any file operations.
- Read or write anything in the broadest possible meaning, including input/output, environment variables, objects from the operating system or from the program or other processes, shared memory, sockets, etc.
- Access any persistent data, like global or static variables.

If a **pure** function does not obey the above restrictions, SystemVerilog compiler optimizations can lead to unexpected behavior, due to eliminated calls or incorrect results being used.

H.6.7 Memory management

See also [35.5.1.4](#).

The memory spaces owned and allocated by C code and SystemVerilog code are disjointed. Each side is responsible for its own allocated memory. Specifically, C code shall not free the memory allocated by SystemVerilog code (or the SystemVerilog compiler) nor expect SystemVerilog code to free the memory allocated by C code (or the C compiler). This does not exclude scenarios in which C code allocates a block of memory and then passes a handle (i.e., a pointer) to that block to SystemVerilog code, which in turn calls a C function that directly (if it is the standard function `free`) or indirectly frees that block.

NOTE—In this last scenario, a block of memory is allocated and freed in C code, even when the standard functions `malloc` and `free` are called directly from SystemVerilog code.

H.7 Data types

This subclause defines the data types of the C layer of the DPI.

H.7.1 Limitations

Packed arrays can have an arbitrary number of dimensions although they are eventually always equivalent to a one-dimensional packed array and treated as such. If the packed part of an array in the type of a formal argument in SystemVerilog is specified as multidimensional, the SystemVerilog compiler linearizes it. Although the original ranges are generally preserved for open arrays, if the actual argument has a multidimensional packed part of the array, it shall be linearized and normalized into an equivalent one-dimensional packed array. (See [H.7.5](#)).

NOTE—The actual argument can have both packed and unpacked parts of an array; either can be multidimensional.

H.7.2 Duality of types: SystemVerilog types versus C types

A value that crosses the DPI is specified in SystemVerilog code as a value of SystemVerilog type, while the same value shall be specified in C code as a value of C type. Therefore, each data type that is passed through the DPI requires two matching type definitions: the SystemVerilog definition and C definition.

The user needs to provide such matching definitions. Specifically, for each SystemVerilog type used in the import declarations or export declarations in SystemVerilog code, the user shall provide the equivalent type definition in C reflecting the argument passing mode for the particular type of SystemVerilog value and the direction (`input`, `output`, or `inout`) of the formal SystemVerilog argument.

H.7.3 Data representation

DPI imposes the following additional restrictions on the representation of SystemVerilog data types:

- SystemVerilog types that are not packed and that do not contain packed elements have C-compatible representation.
- Basic integer and real data types are represented as defined in [H.7.4](#).
- Packed types, including `time`, `integer` and appropriate user-defined types, are represented using the canonical format defined in [H.7.7](#).
- Enumeration types are represented by C base types that correspond to the enumeration types' SystemVerilog base types (see [Table H.1](#)). `integer` and `time` base types are represented as 4-state packed arrays. The base type determines whether an enumeration type is considered a small value (see [35.5.5](#)). DPI supports all the SystemVerilog enumeration base types (see [6.19](#) and [A.2.2.1](#)). Enumerated names are not available on the C side of the interface.
- Unpacked arrays embedded in a structure have C-compatible layout regardless of the type of elements. Similarly, standalone arrays passed as actuals to a sized formal argument have C-compatible representation.
- For a standalone array passed as an actual to an open array formal
 - If the element type is a 2- or 4-state scalar or packed type, then the representation is in canonical form.
 - Otherwise, the representation is C compatible. Therefore, an element of an array shall have the same representation as an individual value of the same type. Hence, an array's elements can be accessed from C code via normal C array indexing similarly to doing so for individual values.
- The natural order of elements for each dimension in the layout of an unpacked array shall be used, i.e., elements with lower indices go first. For SystemVerilog range `[L:R]`, the element with

SystemVerilog index $\min(L, R)$ has the C index 0 and the element with SystemVerilog index $\max(L, R)$ has the C index $\text{abs}(L-R)$.

H.7.4 Basic types

[Table H.1](#) defines the mapping between the basic SystemVerilog data types and the corresponding C types.

Table H.1—Mapping data types

SystemVerilog type	C type
<code>byte</code>	<code>char</code>
<code>shortint</code>	<code>short int</code>
<code>int</code>	<code>int</code>
<code>longint</code>	<code>long long</code>
<code>real</code>	<code>double</code>
<code>shortreal</code>	<code>float</code>
<code>chandle</code>	<code>void^a</code>
<code>string</code>	<code>const char^a</code>
<code>bit^a</code>	<code>unsigned char</code>
<code>logic^a/reg</code>	<code>unsigned char</code>

^aEncodings for `bit` and `logic` are given in file `svdpi.h`. `reg` parameters can use the same encodings as `logic` parameters.

The DPI also supports the SystemVerilog and C unsigned integer data types that correspond to the mappings [Table H.1](#) shows for their signed equivalents.

The `input` mode arguments of type `byte unsigned` and `shortint unsigned` are not equivalent to `bit[7:0]` or `bit[15:0]`, respectively, because the former are passed as C types `unsigned char` and `unsigned short` and the latter are both passed by reference as `svBitVecVal` types. A similar lack of equivalence applies to passing such parameters by reference for `output` and `inout` modes, e.g., `byte unsigned` is passed as C type `unsigned char*` while `bit[7:0]` is passed by reference as `svBitVecVal`.

In addition to declaring DPI formal arguments of packed `bit` and `logic` arrays, it is also possible to declare formal arguments of packed `struct` and `union` types. DPI handles these types as if they were declared with equivalent one-dimensional packed array syntax. See [6.22.2](#). The tag value for both 2 and 4-state packed unions is a 2-state value, stored in the most significant bits of the `svBitVecVal` canonical form for 2-state packed arrays and in the most significant ‘a’ field bits of the `svLogicVecVal` canonical form for 4-state packed arrays. See [7.3.2](#) for tag values and size, [H.7.7](#) and [H.10.1.2](#) for canonical forms.

Refer to [H.7.8](#) for details on unpacked aggregate types that are composed of the basic types described in this subclause.

The SystemVerilog `rand` and `randc` qualifiers can appear in DPI struct and union formal argument declarations and can be associated with SystemVerilog actual arguments to DPI imports. In both cases these qualifiers do not affect processing on the C side and the arguments associated with them are subjected to DPI type coercion principles (see [H.6](#)).

The handling of string types varies depending on the argument passing mode. Refer to [H.8.10](#) for further details.

H.7.5 Normalized and linearized ranges

Packed arrays are treated as one-dimensional; the unpacked part of an array can have an arbitrary number of dimensions. Normalized ranges mean $[n-1:0]$ indexing for the packed part and $[0:n-1]$ indexing for a dimension of the unpacked part of an array. Normalized ranges are used for accessing all array arguments, except for the unpacked dimensions of open arrays. The canonical representation of packed arrays also uses normalized ranges.

Linearizing a SystemVerilog array with multiple packed dimensions consists of treating an array with dimension sizes (i, j, k) as if it had a single dimension with size $(i * j * k)$ and had been stored as a one-dimensional array. The one-dimensional array has the same layout as the corresponding multidimensional array stored in row-major order. User C code can take the original dimensions into account when referencing a linearized array element. For example, the bit in a SystemVerilog packed 2-state array with dimension sizes (i, j, k) and a SystemVerilog reference `myArray[l][m][n]` (where the ranges for $l, m,$ and n have been normalized) maps to linearized C array bit $(n + (m * k) + (l * j * k))$.

H.7.6 Mapping between SystemVerilog ranges and C ranges

The range of a sized dimension in an open array formal argument is specified by the import or export declaration. Each unsized, unpacked dimension has the same range as the corresponding dimension of the actual argument. An open array formal argument's unsized, packed dimension has the linearized, normalized range of all the actual's packed dimensions (see [H.7.5](#)). Utility functions provide the original ranges of open array unpacked dimensions and the normalized range of the packed dimension (see [H.12.2](#)). For all types of formal argument other than open arrays, the SystemVerilog ranges are defined in the corresponding SystemVerilog import or export declaration. Normalized ranges are used for accessing such arguments in C code. C ranges for multiple packed dimensions are linearized and normalized. The mapping between SystemVerilog ranges and C ranges is defined as follows:

- If a packed part of an array has more than one dimension, it is linearized as specified by the equivalence of packed types (see [H.7.5](#) and [6.22.2](#)).
- A packed array of range $[L:R]$ is normalized as $[\text{abs}(L-R):0]$; its MSB has a normalized index $\text{abs}(L-R)$ and its LSB has a normalized index 0.
- The natural order of elements for each dimension in the layout of an unpacked array shall be used, i.e., elements with lower indices go first. For SystemVerilog range $[L:R]$, the element with SystemVerilog index $\min(L, R)$ has the C index 0 and the element with SystemVerilog index $\max(L, R)$ has the C index $\text{abs}(L-R)$.

The above range mapping from SystemVerilog to C applies to calls made in both directions, i.e., SystemVerilog calls to C and C calls to SystemVerilog.

For example, if `logic [2:3][1:3][2:0] b [1:10] [31:0]` is used in SystemVerilog, it needs to be defined in C as if it were declared in SystemVerilog in the following normalized form: `logic [17:0] b [0:9] [0:31]`.

H.7.7 Canonical representation of packed arrays

The DPI defines the canonical representation of packed 2-state (type `svBitVecVal`) and 4-state arrays (type `svLogicVecVal`). `svLogicVecVal` is fully equivalent to type `s_vpi_vecval`, which is used to represent 4-state logic in VPI.

A packed array is represented as an array of one or more elements (of type `svBitVecVal` for 2-state values and `svLogicVecVal` for 4-state values), each element representing a group of 32 bits. The first element of an array contains the 32 LSBs, next element contains the 32 more significant bits, and so on. The last element can contain a number of unused bits. The contents of these unused bits are undetermined, and the user is responsible for the masking or the sign extension (depending on the sign) for the unused bits.

H.7.8 Unpacked aggregate arguments

Imported and exported DPI tasks and functions can make use of unpacked aggregate types as formal or actual arguments. Aggregate types include unpacked arrays and structures. Such types can be composed of packed elements, unpacked elements, or combinations of either kind of element, including subaggregates. Refer to [Table H.1](#) for a list of legal basic types that can be used as nonaggregate elements in aggregate types. Also refer to [35.5.6](#).

In the case of an unpacked type that consists purely of unpacked elements (including subaggregates), the layout presented to the C programmer is guaranteed to be compatible with the C compiler's layout on the given operating system. It is also possible for unpacked aggregate types to include packed elements.

H.8 Argument passing modes

This subclause defines the ways to pass arguments in the C layer of the DPI.

H.8.1 Overview

Imported and exported function arguments are generally passed by some form of a reference, with the exception of small values of SystemVerilog input arguments (see [H.8.7](#)), which are passed by value. Similarly, the function result, which is restricted to small values, is passed by value, i.e., directly returned.

Formal arguments, except open arrays, are passed by direct reference or value and, therefore, are directly accessible in C code. Formal arguments declared in SystemVerilog as open arrays are passed by a handle (type `svOpenArrayHandle`) and are accessible via library functions.

H.8.2 Calling SystemVerilog tasks and functions from C

There is no difference in argument passing between calls from SystemVerilog to C and calls from C to SystemVerilog. Tasks and functions exported from SystemVerilog cannot have open arrays as arguments. Apart from this restriction, the same types of formal arguments can be declared in SystemVerilog for exported tasks and functions and imported tasks and functions. A subroutine exported from SystemVerilog shall have the same function header in C as would an imported function with the same function result type and same formal argument list. In the case of arguments passed by reference, an actual argument to SystemVerilog subroutine called from C shall be allocated using the same layout of data as SystemVerilog uses for that type of argument; the caller is responsible for the allocation. It can be done while preserving the binary compatibility (see [H.12.5](#) and [H.13](#)).

Calling a SystemVerilog task from C is the same as calling a SystemVerilog function from C with the exception that the return type of an exported task is an `int` value that has a special meaning related to `disable` statements. See [35.9](#) for details on disable processing by DPI imported tasks and functions.

H.8.3 Argument passing by value

Only small values of formal input arguments (see [H.8.7](#)) are passed by value. Function results are also directly passed by value. The user needs to provide the C type equivalent to the SystemVerilog type of a formal argument if an argument is passed by value.

H.8.4 Argument passing by reference

For arguments passed by reference, a reference (a pointer) to the actual data object is passed. In the case of packed data, a reference to a canonical data object is passed. The actual argument is usually allocated by a caller. The caller can also pass a reference to an object already allocated somewhere else, for example, its own formal argument passed by reference.

If an argument of type `T` is passed by reference, the formal argument shall be of type `T*`. Packed arrays are passed using a pointer to the appropriate canonical type definition, either `svLogicVecVal*` or `svBitVecVal*`.

There shall be no assumptions made in DPI C applications about the lifetime of pass-by-reference arguments. If it is required to store a pass-by-reference argument's value across multiple DPI calls, then the value must be copied into memory owned and managed by the C application.

H.8.5 Allocating actual arguments for SystemVerilog-specific types

This is relevant only for calling exported SystemVerilog subroutines from C code. The caller is responsible for allocating any actual arguments that are passed by reference.

Static allocation requires knowledge of the relevant data type. If such a type involves SystemVerilog packed arrays, corresponding C arrays of canonical data types (either `svLogicVecVal` or `svBitVecVal`) must be allocated and initialized before being passed by reference to the exported SystemVerilog subroutine.

H.8.6 Argument passing by handle—open arrays

Arguments specified as open (unsized) arrays are always passed by a handle, regardless of direction of the SystemVerilog formal argument, and are accessible via library functions. The actual implementation of a handle is tool-specific and transparent to the user. A handle is represented by the generic pointer `void*` (typedefed to `svOpenArrayHandle`). Arguments passed by handle shall always have a `const` qualifier because the user shall not modify the contents of a handle.

H.8.7 Input arguments

`input` arguments of imported functions implemented in C shall always have a `const` qualifier.

`input` arguments, with the exception of open arrays, are passed by value or by reference, depending on the size. Small values of formal input arguments are passed by value. The following data types are considered *small*:

— `byte`, `shortint`, `int`, `longint`, `real`, `shortreal`

- Scalar `bit` and `logic`
- `chandle`, `string`

`input` arguments of other types are passed by reference.

H.8.8 Inout and output arguments

`inout` and `output` arguments, with the exception of open arrays, are always passed by reference. Specifically, packed arrays are passed, accordingly, as `svBitVecVal*` or `svLogicVecVal*`. The same rules about unused bits apply as in [H.7.7](#).

H.8.9 Function result

Types of a function result are restricted to the following SystemVerilog data types (see [Table H.1](#) for the corresponding C type):

- `byte`, `shortint`, `int`, `longint`, `real`, `shortreal`, `chandle`, `string`
- Scalar values of type `bit` and `logic`

Encodings for `bit` and `logic` are given in file `svdpi.h`. Refer to [H.10.1.1](#).

H.8.10 String arguments

The layout of SystemVerilog string objects is implementation dependent. However, when a string value is passed from SystemVerilog to C, implementations shall lay out all characters in memory per C string conventions, including a trailing null character present at the end of the C string. Similarly, users shall make sure that any C strings passed to SystemVerilog are properly null-terminated.

The direction mode for string arguments applies to the pointer to the string (i.e., the `const char*` variable in [Table H.1](#)), not to the characters that compose the string.

Thus, the direction modes have the following meanings for imported tasks and functions:

- An `input` mode string is accessed through a pointer value that is provided by SystemVerilog and that shall not be freed by the DPI C application. There shall be no assumptions made in the C application about the lifetime of this string storage. No user changes to this pointer value are propagated back to the SystemVerilog sphere.
- An `output` mode string does not arrive at the C interface with a meaningful value. It is represented by a `const char**` variable. Upon return to SystemVerilog, the DPI application shall have written a valid and initialized `const char*` address into the `const char**` variable. SystemVerilog shall not free memory accessed through this address.
- An `inout` mode string arrives at the C interface with a valid string address value stored in a `const char**` variable. The string's storage shall not be freed by the DPI C application. There shall be no assumptions made in the C application about the lifetime of the string storage. Any changes to the string shall be effected by the C application providing a new pointer value, which points to new string contents and which SystemVerilog shall not attempt to free. The C application provides a new string pointer value by writing the string's address into the `const char**` variable. If the pointer value is modified by the C application, SystemVerilog copies the indicated string contents into its memory space and undertakes any actions sensitive to this change.

The direction modes have the following meanings for exported tasks and functions:

- An **input** mode string is passed to SystemVerilog through a `const char*` pointer. SystemVerilog only reads from the string. It shall not modify the characters that compose the string.
- An **output** mode string is represented by a `const char**` variable. No meaningful initial value is stored in the pointer variable. SystemVerilog shall write a valid string address into the output `const char**` variable. The user shall not make any assumptions about the lifetime of the output string's storage, and the C code shall not free the string memory. If it is desired to refer to the string's value at some point in the future, the user shall copy the string value to memory owned by the C domain.
- An **inout** mode string is represented by a `const char**` variable that contains a pointer to memory allocated and initialized by the user. SystemVerilog only reads from the user's string storage, and it will not attempt to modify or free this storage. If SystemVerilog needs to effect a change in the value of the inout mode string, then a valid SystemVerilog string address is written into the `const char**` variable. The user shall not make any assumptions about the lifetime of this string storage, nor should the SystemVerilog storage be freed by C code. If it is desired to refer to the modified string value at some point in the future, the user shall copy the string value to memory owned by the C domain.

H.8.10.1 String types in aggregate arguments

When strings are contained in aggregate arguments, those string members shall also be represented by `const char*` variables. All the same stipulations apply to string members of aggregate arguments as apply to standalone string arguments.

NOTE—With arrays of string arguments, there is no need for the extra level of indirection that occurs with standalone string output and inout arguments. By the rules specified in [H.7.8](#), all arrays of string arguments are represented in C as `const char**`, regardless of their directionality.

H.9 Context tasks and functions

Some DPI imported tasks and functions require that the context of their call be known. For example, those calls can be associated with instances of C models that have a one-to-one correspondence with instances of SystemVerilog modules that are making the calls. Alternatively, a DPI imported subroutine might need to access or modify simulator data structures using VPI calls or by making a call back into SystemVerilog via an export subroutine. Context knowledge is required for such calls to function properly. It can take special instrumentation of their call to provide such context.

To avoid any unnecessary overhead, imported subroutine calls in SystemVerilog code are not instrumented unless the imported subroutine is specified as context in its SystemVerilog import declaration. A DPI-C context *call chain* is a sequence of C subroutine invocations that starts with a SystemVerilog entity calling a DPI-C import declared with the **context** keyword and continues in C, unbroken by a call back into SystemVerilog. A small set of DPI utility functions is available to assist programmers when working with context subroutines (see [H.9.3](#)). The behavior of DPI utility functions that manipulate context is undefined when they are invoked by any subroutine that is not part of a DPI context call chain (see [35.5.3](#)). Similarly, the behavior of exported subroutines is undefined when they are invoked by a DPI call chain that lacks the context characteristic.

H.9.1 Overview of DPI and VPI context

Both DPI subroutines and VPI functions might need to understand their context. However, the meaning of the term is different for the two categories of subroutines.

DPI imported tasks and functions are essentially proxies for native SystemVerilog tasks and functions. Native SystemVerilog tasks and functions always operate in the scope of their declaration site. For example,

a native SystemVerilog function $f()$ can be declared in a module m , which is instantiated as $top.i1.m$. The $top.i1.m$ instance of $f()$ can be called via hierarchical reference from code in a distant design region. Function $f()$ is said to execute in the context (i.e., instantiated scope) of $top.i1.m$ because it has unqualified visibility only for variables local to that specific instance of m . Function $f()$ does not have unqualified visibility for any variables in the calling code's scope.

DPI imported tasks and functions follow the same model as native SystemVerilog tasks and functions. They execute in the context of their surrounding declarative scope, rather than the context of their call sites. This type of context is termed *DPI context*.

This is in contrast to VPI functions. Such functions execute in a context associated with their call sites. The VPI programming model relies on C code's ability to retrieve a context handle associated with the associated system task's call site and then to work with the context handle to glean information about arguments, items in the call site's surrounding declarative scope, etc. This type of context is termed *VPI context*.

The SystemVerilog context of DPI export tasks and functions must be known when they are called, including when they are called by imports. When an import invokes the `svSetScope` utility prior to calling the export, it sets the context explicitly. Otherwise, the context will be the context of the instantiated scope where the import declaration is located. Because imports with diverse instantiated scopes can export the same subroutine, multiple instances of such an export can exist after elaboration. Prior to any invocations of `svSetScope`, these export instances would have different contexts, which would reflect their imported caller's instantiated scope.

H.9.2 Context of imported and export tasks and functions

DPI imported and export tasks and functions can be declared in a **module**, **program**, **interface**, **package**, compilation unit scope, or **generate** declarative scope.

A context imported subroutine executes in the context of the instantiated scope surrounding its declaration. In other words, such tasks and functions can see other variables in that scope without qualification. As explained in [H.9.1](#), this should not be confused with the context of the task's or function's call site, which can actually be anywhere in the SystemVerilog design hierarchy. The context of an imported or exported subroutine corresponds to the fully qualified name of the subroutine, minus the subroutine name itself.

The context property is transitive through imported and export context tasks and functions declared in the same scope. In other words, if an imported subroutine is running in a certain context and if it in turn calls an exported subroutine that is available in the same context, the exported subroutine can be called without any use of `svSetScope()`. For example, consider a SystemVerilog call to a native function $f()$, which in turn calls a native function $g()$. Now replace the native function $f()$ with an equivalent imported context C function, $f'()$. The system shall behave identically regardless if $f()$ or $f'()$ is in the call chain above $g()$. $g()$ has the proper execution context in both cases.

When control passes across the boundary between SystemVerilog and a DPI import call chain with the context property, the value of the import's context is potentially either set or reset (see [35.5.3](#)). Therefore, user code behavior is undefined for DPI import C code that circumvents SystemVerilog exports unwinding across the boundary to their import caller (e.g., by using C `setjmp` and `longjmp` constructs).

H.9.3 Working with DPI context tasks and functions in C code

DPI defines a small set of functions to help programmers work with DPI context tasks and functions. The term *scope* is used in the subroutine names for consistency with other SystemVerilog terminology. The terms *scope* and *context* are equivalent for DPI tasks and functions. A DPI context imported subroutine is declared with the **context** keyword. A DPI-C context *call chain* is a sequence of calls to C subroutines that

begins with a SystemVerilog entity calling a DPI context import and continues in C, unbroken by a call back into SystemVerilog.

There are functions that allow the user to retrieve and manipulate the current operational scope. The behavior of these functions is undefined if they are invoked by an entity other than a member of a DPI context call chain. The behavior of exported subroutines is undefined when they are invoked by a member of a DPI call chain that lacks the context characteristic.

There are also functions that provide users with the power to set data specific to C models into the SystemVerilog simulator for later retrieval. These are the “put” and “get” user data functions, which are similar to facilities provided in VPI.

The put and get user data functions are flexible and allow for a number of use models. Users might wish to share user data across multiple context imported functions defined in the same SystemVerilog scope. Users might wish to have unique data storage on a per-function basis. Shared or unique data storage is controllable by a user-defined key.

To achieve shared data storage, a related set of context imported tasks and functions should all use the same user key. To achieve unique data storage, a context import subroutine should use a unique key, and it is a requirement on the user that such a key be truly unique from all other keys that could possibly be used by C code. This includes completely unknown C code that could be running in the same simulation. It is suggested that taking addresses of static C symbols (such as a function pointer or an address of some static C data) always be done for user key generation. Generating keys based on arbitrary integers is not a safe practice.

It is never possible to share user data storage across different contexts. For example, if a SystemVerilog module *m* declares a context imported subroutine *f*, and *m* is instantiated more than once in the SystemVerilog design, then *f* shall execute under different values of *svScope*. No such executing instances of *f* can share user data with each other, at least not using the system-provided user data storage area accessible via *svPutUserData()*.

A user wanting to share a data area across multiple contexts must do so by allocating the common data area and then storing the pointer to it individually for each of the contexts in question via multiple calls to *svPutUserData()*. This is because, although a common user key can be used, the data must be associated with the individual scopes (denoted by *svScope*) of those contexts.

```
/* Functions for working with DPI context functions */

/* Retrieve the active instance scope currently associated with the executing
 * imported function.
 * Unless a prior call to svSetScope has occurred, this is the scope of the
 * function's declaration site, not call site.
 * The return value is undefined if this function is invoked from a noncontext
 * imported function.
 */
svScope svGetScope();

/* Set context for subsequent export function execution.
 * This function must be called before calling an export function, unless
 * the export function is called while executing an import function. In that
 * case the export function shall inherit the scope of the surrounding import
 * function. This is known as the "default scope".
 * The return is the previous active scope (per svGetScope)
 */
svScope svSetScope(const svScope scope);
```

```
/* Gets the fully qualified name of a scope handle */
const char* svGetNameFromScope(const svScope);

/* Retrieve svScope to instance scope of an arbitrary function declaration.
 * (can be either module, program, interface, or generate scope)
 * The return value shall be NULL for unrecognized scope names.
 */
svScope svGetScopeFromName(const char* scopeName);

/* Store an arbitrary user data pointer for later retrieval by svGetUserData()
 * The userKey is generated by the user. It must be guaranteed by the user to
 * be unique from all other userKey's for all unique data storage requirements
 * It is recommended that the address of static functions or variables in the
 * user's C code be used as the userKey.
 * It is illegal to pass in NULL values for either the scope or userData
 * arguments. It is also an error to call svPutUserData() with an invalid
 * svScope. This function returns -1 for all error cases, 0 upon success. It is
 * suggested that userData values of 0 (NULL) not be used as otherwise it can
 * be impossible to discern error status returns when calling svGetUserData()
 */
int svPutUserData(const svScope scope, void *userKey, void* userData);

/* Retrieve an arbitrary user data pointer that was previously
 * stored by a call to svPutUserData(). See the comment above
 * svPutUserData() for an explanation of userKey, as well as
 * restrictions on NULL and illegal svScope and userKey values.
 * This function returns NULL for all error cases, and a non-Null
 * user data pointer upon success.
 * This function also returns NULL in the event that a prior call
 * to svPutUserData() was never made.
 */
void* svGetUserData(const svScope scope, void* userKey);

/* Returns the file and line number in the SV code from which the import call
 * was made. If this information available, returns TRUE and updates fileName
 * and lineNumber to the appropriate values. Behavior is unpredictable if
 * fileName or lineNumber are not appropriate pointers. If this information is
 * not available return FALSE and contents of fileName and lineNumber not
 * modified. Whether this information is available or not is implementation-
 * specific. Note that the string provided (if any) is owned by the SV
 * implementation and is valid only until the next call to any SV function.
 * Applications must not modify this string or free it
 */
int svGetCallerInfo(const char **fileName, int *lineNumber);
```

H.9.4 Example 1—Using DPI context functions

SV Side:

```
// Declare an imported context sensitive C function with cname "MyCFunc"
import "DPI-C" context MyCFunc = function integer MapID(int portID);
```

C Side:

```
// Define the function and model class on the C++ side:
class MyCModel {
private:
```



```
    int locallyMapped(int portID); // Does something interesting...
public:
    // Constructor
    MyCModel(const char* instancePath) {
        svScope svScope = svGetScopeByName(instancePath);

        // Associate "this" with the corresponding SystemVerilog scope
        // for fast retrieval during run time.
        svPutUserData(svScope, (void*) MyCFunc, this);
    }

    friend int MyCFunc(int portID);
};

// Implementation of imported context function callable in SV
int MyCFunc(int portID) {
    // Retrieve SV instance scope (i.e., this function's context).
    svScope = svGetScope();

    // Retrieve and make use of user data stored in SV scope
    MyCModel* me = (MyCModel*)svGetUserData(svScope, (void*) MyCFunc);
    return me->locallyMapped(portID);
}
```

H.9.5 Relationship between DPI and VPI

DPI allows C code to run in the context of a SystemVerilog simulation; thus it is natural for users to consider using VPI C code from within imported tasks and functions.

There is no specific relationship defined between DPI and VPI. Programmers must make no assumptions about how DPI and the other interfaces interact. For example, a `vpiHandle` is not equivalent to an `svOpenArrayHandle`, and the two must not be interchanged and passed between functions defined in the two different interfaces.

If a user wants to call VPI functions from within an imported subroutine, the imported subroutine must be flagged with the context qualifier.

Not all VPI functionality is available from within DPI context imported tasks and functions. For example, a SystemVerilog imported subroutine is not a system task, and thus making the following call from within an imported subroutine would result in an error:

```
/* Get handle to system task call site in preparation for argument scan */
vpiHandle myHandle = vpi_handle(vpiSysTfCall, NULL);
```

Similarly, callbacks and other activities associated with system tasks are not supported inside DPI imported tasks and functions. Users should use VPI if they wish to accomplish such actions.

However, the following kind of code will work reliably from within DPI context imported tasks and functions:

```
/* Prepare to scan all top-level modules */
vpiHandle myHandle = vpi_iterate(vpiModule, NULL);
```

H.10 Include files

The C layer of the DPI defines one include file, `svdpi.h`. This file is implementation independent and defines the canonical representation, all basic types, and all interface functions. The actual file is shown in [Annex I](#).

H.10.1 Include file `svdpi.h`

Applications that use the DPI with C code usually need this main include file. The include file `svdpi.h` defines the types for canonical representation of 2-state (**bit**) and 4-state (**logic**) values and passing references to SystemVerilog data objects, provides function headers, and defines a number of helper macros and constants.

This standard fully defines the `svdpi.h` file. The content of `svdpi.h` does not depend on any particular implementation or platform; all simulators shall use the same file. Subclauses [H.10.1.1](#), [H.10.1.2](#), and [H.10.1.3](#) (and [H.13](#)) detail the contents of the `svdpi.h` file.

H.10.1.1 Scalars of type **bit** and **logic**

```
/* canonical representation */

#define sv_0    0
#define sv_1    1
#define sv_z    2 /* representation of 4-st scalar z */
#define sv_x    3 /* representation of 4-st scalar x */

/* common type for 'bit' and 'logic' scalars. */
typedef unsigned char svScalar;

typedef svScalar svBit;      /* scalar */
typedef svScalar svLogic;   /* scalar */
```

H.10.1.2 Canonical representation of packed arrays

```
/*
 * DPI representation of packed arrays.
 * 2-state and 4-state vectors, exactly the same as PLI's avalue/bvalue.
 */
#ifndef VPI_VECVAL
#define VPI_VECVAL
typedef struct t_vpi_vecval {
    uint32_t aval;
    uint32_t bval;
} s_vpi_vecval, *p_vpi_vecval;
#endif

/* (a chunk of) packed logic array */
typedef s_vpi_vecval svLogicVecVal;

/* (a chunk of) packed bit array */
typedef uint32_t svBitVecVal;

/* Number of chunks required to represent the given width packed array */
#define SV_PACKED_DATA_NELEMS(WIDTH) (((WIDTH) + 31) >> 5)

/*
 * Because the contents of the unused bits is undetermined,
 * the following macros can be handy.
```

```
*/  
#define SV_MASK(N) (~(-1 << (N)))  
  
#define SV_GET_UNSIGNED_BITS(VALUE, N) \  
    ((N) == 32 ? (VALUE) : ((VALUE) & SV_MASK(N)))  
  
#define SV_GET_SIGNED_BITS(VALUE, N) \  
    ((N) == 32 ? (VALUE) : \  
    (((VALUE) & (1 << (N))) ? ((VALUE) | ~SV_MASK(N)) : ((VALUE) & SV_MASK(N))))
```

H.10.1.3 Implementation-dependent representation

The `svDpiVersion()` function returns a string indicating which DPI standard is supported by the simulator and in particular which canonical value representation is being provided. For example, a tool that is based on IEEE Std 1800-2005, i.e., the VPI-based canonical value, shall return the string "1800-2005". Simulators implementing to the prior Accellera SV3.1a standards, and thus using the `svLogicVec32` value representation, shall return the string "SV3.1a".

```
/* Returns either version string "1800-2005" or "SV3.1a" */  
const char* svDpiVersion();  
  
/* a handle to a scope (an instance of a module or an interface) */  
typedef void *svScope;  
  
/* a handle to a generic object (actually, unsized array) */  
typedef void* svOpenArrayHandle;
```

H.10.2 Example 2—Simple packed array application

SystemVerilog:

```
typedef struct {int x; int y;} pair;  
import "DPI-C" function void f1(input int i1, pair i2,  
                               output logic [63:0] o3);  
  
export "DPI-C" function exported_sv_func;  
  
function void exported_sv_func(input int i, output int o [0:7]);  
    begin ... end  
endfunction
```

C:

```
#include "svdpi.h"  
  
typedef struct {int x; int y;} pair;  
  
extern void exported_sv_func(int, int *); /* imported from SystemVerilog */  
  
void f1(const int i1, const pair *i2, svLogicVecVal* o3)  
{  
    int tab[8];  
  
    printf("%d\n", i1);  
    o3[0].aval = i2->x;  
    o3[0].bval = 0;  
    o3[1].aval = i2->y;  
    o3[1].b = 0;  
}
```

```

    /* call SystemVerilog */
    exported_sv_func(i1, tab); /* tab passed by reference */
    ...
}

```

H.10.3 Example 3—Application with complex mix of types

SystemVerilog:

```

typedef struct {int a; bit [6:1][1:8] b [65:2]; int c;} triple;
    // troublesome mix of C types and packed arrays
import "DPI-C" function void f1(input triple t);

export "DPI-C" function exported_sv_func;

function void exported_sv_func(input int i, output logic [63:0] o);
    begin ... end
endfunction

```

C:

```

#include "svdpi.h"
typedef struct {
    int a;
    svBitVecVal b[64][SV_PACKED_DATA_NELEMS(6*8)];
    int c;
} triple;

/* Note that 'b' is defined as for 'bit [6*8-1:0] b [63:0]' */

extern void exported_sv_func(int, svLogicVecVal*); /* imported from
                                                    SystemVerilog */

void f1(const triple *t)
{
    int i;
    svBitVecVal aB;
    svLogicVecVal aL[SV_PACKED_DATA_NELEMS(64)];

    /* aB holds results of part-select from packed bit array 'b' in
       struct triple. */
    /* aL holds the packed logic array filled in by the export function. */

    printf("%d %d\n", t->a, t->c);
    for (i = 0; i < 64; i++) {
        /* Read least significant byte of each word of b into aB, then
           process... */
        svGetPartselBit(&aB, t->b[i], 0, 8);
        ...
    }
    ...
    /* Call SystemVerilog */
    exported_sv_func(2, aL); /* Export function writes data into
                               output arg "aL" */
    ...
}

```

H.11 Arrays

Normalized ranges are used for accessing SystemVerilog arrays, with the exception of formal arguments specified as open arrays.

H.11.1 Example 4—Using packed 2-state arguments

This example shows two alternatives for working with 2-state packed data types. The first argument shows classical `int`-to-`int` correspondence per [Table H.1](#). The second argument demonstrates that a DPI formal argument can be of a C-compatible type and that arbitrary 2-state bit vector actual arguments can be associated with that C-compatible formal argument. The third argument shows a portable technique for handling an arbitrary width 2-state vector. This technique is less efficient than techniques involving C-compatible formal arguments, but it is required when 2-state vectors exceed 64 bits in length.

```
// SV code
module m;

    parameter W = 33;
    int abv1;
    bit [29:0] abv2;
    bit [W-1:0] abv3;

    // Two ways of handling 2-state packed array arguments
    import "DPI-C" function void f7 (input int unsigned fbv1,
                                     input int unsigned fbv2,
                                     input [W-1:0] fbv3);

    initial
        f7(abv1, abv2, abv3);
endmodule

/* C code */
void f7(unsigned int fbv1, unsigned int fbv2,
        const svBitVecVal* fbv3)
{
    printf("fbv1 is %d, fbv2 is %d\n", fbv1, fbv2);
    /* Use of the 2-state svdpi utilities is needed to transform fbv3 into a
       C representation */
}
```

H.11.2 Multidimensional arrays

Multiple packed dimensions of a SystemVerilog array are linearized (see [H.7.5](#)). Unpacked arrays can have an arbitrary number of dimensions.

H.11.3 Example 5—Using packed struct and union arguments

This example shows how packed `struct` and `union` arguments correspond to one-dimensional packed array arguments.

```
// SV code
module m;
```

```

typedef bit [2:0] A;
typedef struct packed { bit a; bit b; bit c; } S;
typedef union packed { A a; S s; } U;
S s;
U u;
A a;

// Import function takes three arguments
import "DPI-C" function void f8(input A fa, input S fs, input U fu);

initial begin
    s.a = 1'b1;
    s.b = 1'b0;
    s.c = 1'b0;
    a = 3'b100;
    u.a = 3'b100;
    f8(a, s, u);
end

endmodule

/* C code */
void f8(
    const svBitVecVal* fa,
    const svBitVecVal* fs,
    const svBitVecVal* fu)
{
    printf("fa is %d, fs is %d, fu is %d\n", *fa, *fs, *fu);
}

```

The output of the printf will be “fa is 4, fs is 4, fu is 4”.

H.11.4 Direct access to unpacked arrays

Unpacked arrays, with the exception of formal arguments specified as open arrays, shall have the same layout as used by a C compiler; they are accessed using C indexing (see [H.7.6](#)).

H.11.5 Utility functions for working with the canonical representation

Packed arrays are accessible via canonical representation. This C layer interface provides utility functions for working with bit-selects and limited (up to 32-bit) part-selects in the canonical representation.

A part-select is a slice of a packed array of types **bit** or **logic**. Array slices are not supported for unpacked arrays. Functions for part-selects only allow access (read/write) to a narrow subrange of up to 32 bits. If the specified range of a part-select is not fully contained within the normalized range of an array, the behavior is undetermined.

DPI utilities behave in the following way, given part-select arguments of width *w* and starting index *i*: A utility puts part-select source bits [*w*-1:0] into destination bits [(*i*+*w*-1):*i*] without changing the values of destination bits that surround the part-select. A utility gets part-select source bits [(*i*+*w*-1):*i*] and copies them into destination bits [*w*-1:0]. If *w* < 32, destination bits [31:*w*] shall be left unchanged by the get part-select operation.

```

/*
 * Bit-select utility functions.

```

```
*
* Packed arrays are assumed to be indexed n-1:0,
* where 0 is the index of LSB
*/

/* s=source, i=bit-index */
svBit svGetBitselBit(const svBitVecVal* s, int i);
svLogic svGetBitselLogic(const svLogicVecVal* s, int i);

/* d=destination, i=bit-index, s=scalar */
void svPutBitselBit(svBitVecVal* d, int i, svBit s);
void svPutBitselLogic(svLogicVecVal* d, int i, svLogic s);

/*
* Part-select utility functions.
*
* A narrow (<=32 bits) part-select is extracted from the
* source representation and written into the destination word.
*
* Normalized ranges and indexing [n-1:0] are used for both arrays.
*
* s=source, d=destination, i=starting bit index, w=width
* like for variable part-selects; limitations: w <= 32
*/
void svGetPartselBit(svBitVecVal* d, const svBitVecVal* s, int i, int w);
void svGetPartselLogic(svLogicVecVal* d, const svLogicVecVal* s, int i, int w);

void svPutPartselBit(svBitVecVal* d, const svBitVecVal s, int i, int w);
void svPutPartselLogic(svLogicVecVal* d, const svLogicVecVal s, int i, int w);
```

H.12 Open arrays

Formal arguments specified as open arrays allows passing actual arguments of different sizes (i.e., different range and/or different number of elements), which facilitates writing more general C code that can handle SystemVerilog arrays of different sizes. The elements of an open array can be accessed in C by using the same range of indices and the same indexing as in SystemVerilog. Plus, inquiries about the dimensions and the original boundaries of SystemVerilog actual arguments are supported for open arrays.

Both the sole packed dimension (see [H.7.1](#)) and multiple unpacked dimensions can be unsized (see [35.5.6.1](#)).

All formal arguments declared in SystemVerilog as open arrays are passed by `handle` (type `svOpenArrayHandle`), regardless of the direction of a SystemVerilog formal argument. Such arguments are accessible via interface functions that accept the handle. For example, the array address is provided by a call to `svGetArrayPtr`.

For inout or output mode open array arguments the space available for user C code output is determined by the actual argument's size. The result of user C code writing more data to an open array address than the actual argument's capacity can accommodate is undefined.

H.12.1 Actual ranges

Formal arguments defined as open arrays have sizes and ranges determined by the actual argument on a per-call basis. The programmer shall always have a choice about whether to specify a formal argument as a sized array or as an open (unsized) array.

For sized formal array dimensions, all indices are normalized on the C side (i.e., 0 and up); the programmer needs to know the size of an array and be capable of determining how the ranges of the actual argument map onto C-style ranges (see [H.7.6](#)).

Tip: Programmers can decide to use `[n:0]name[0:k]` style ranges in SystemVerilog.

For unsized, unpacked formal array dimensions, the actual argument's original range and indices are available via query functions (see [H.12.2](#)). For unsized, packed formal array dimensions, the query functions provide a linearized, normalized form of the actual's packed dimensions. Thus, the actual argument's original indices can be retrieved from query functions and used as arguments to copying and access functions (see [H.12.4](#) and [H.12.5](#)). Similarly, the normalized indices of the actual argument's packed dimensions can be retrieved and used with the standard functions for accessing packed array canonical representations (see [H.11.5](#)).

If a formal argument is specified as a sized array, then it shall be passed by reference, with no overhead, and is directly accessible as a normalized array. If a formal argument is specified as an open (unsized) array, then it shall be passed by handle, with some overhead, and is mostly indirectly accessible, again with some overhead.

NOTE—This provides some degree of flexibility and allows the programmer to control the trade-off of performance versus convenience.

The following example shows the use of sized versus unsized arrays in SystemVerilog code:

```
// both unpacked arrays are 64 by 8 elements, packed 16-bit each
logic [15: 0] a_64x8 [63:0][7:0];
logic [31:16] b_64x8 [64:1][-1:-8];

import "DPI-C" function void f1(input logic [] i [][]);
    // 2-dimensional unsized unpacked array of unsized packed logic

import "DPI-C" function void f2(input logic [31:16] i [64:1][-1:-8]);
    // 2-dimensional sized unpacked array of sized packed logic

f1(a_64x8);
f1(b_64x8); // C code can use normalized packed and original unpacked
            // ranges [15:0][64:1][-1:-8]
f2(b_64x8); // C code must use normalized ranges [15:0][0:63][0:7]
```

H.12.2 Array querying functions

These functions are modeled upon the SystemVerilog array querying functions and use the same semantics (see [20.7](#)).

If the dimension is 0, then the query refers to the packed part (which is one-dimensional) of an array, and dimensions > 0 refer to the unpacked part of an array.

```
/* h= handle to open array, d=dimension */
int svLeft(const svOpenArrayHandle h, int d);
int svRight(const svOpenArrayHandle h, int d);
int svLow(const svOpenArrayHandle h, int d);
int svHigh(const svOpenArrayHandle h, int d);
int svIncrement(const svOpenArrayHandle h, int d);
int svSize(const svOpenArrayHandle h, int d);
int svDimensions(const svOpenArrayHandle h);
```

H.12.3 Access functions

There are library functions available for copying data between open array handles and canonical form buffers provided by the C programmer. Likewise, there are functions to obtain the actual address of SystemVerilog data objects or of an individual element of an unpacked array.

Depending on the type of an element of an unpacked array, different access methods shall be used when working with elements.

- Packed arrays (**bit** or **logic**) are accessed via copying to or from the canonical representation.
- Scalars (1-bit value of type **bit** or **logic**) are accessed (read or written) directly.
- Other types of values (e.g., structures) are accessed via generic pointers; a library function calculates an address, and the user needs to provide the appropriate casting.
- Scalars and packed arrays are accessible via pointers only if the implementation supports this functionality (per array), e.g., one array can be represented in a form that allows such access, while another array might use a compacted representation that renders this functionality unfeasible (both occurring within the same simulator).

SystemVerilog allows arbitrary dimensions and, hence, an arbitrary number of indices. To facilitate this, variable argument list functions shall be used. For the sake of performance, specialized versions of all indexing functions are provided for one, two, or three indices.

H.12.4 Access to actual representation

The following functions provide an actual address of the whole array or of its individual elements. These functions shall be used for accessing elements of arrays of types compatible with C. These functions are also useful for vendors because they provide access to the actual representation for all types of arrays.

If the actual layout of the SystemVerilog array passed as an argument for an open unpacked array is different from the C layout, then it is not possible to access such an array as a whole; therefore, the address and size of such an array shall be undefined (0, to be exact). Nonetheless, the addresses of individual elements of an array shall be always supported.

NOTE—No specific representation of an array is assumed here; hence, all functions use a generic pointer `void *`.

```
/* a pointer to the actual representation of the whole array of any type */
/* NULL if not in C layout */
void *svGetArrayPtr(const svOpenArrayHandle);

int svSizeOfArray(const svOpenArrayHandle); /* total size in bytes or 0 if not
                                             in C layout */

/* Return a pointer to an element of the array
   or NULL if index outside the range or null pointer */

void *svGetArrElemPtr(const svOpenArrayHandle, int indx1, ...);

/* specialized versions for 1-, 2- and 3-dimensional arrays: */
void *svGetArrElemPtr1(const svOpenArrayHandle, int indx1);
void *svGetArrElemPtr2(const svOpenArrayHandle, int indx1, int indx2);
void *svGetArrElemPtr3(const svOpenArrayHandle, int indx1, int indx2,
                       int indx3);
```

Access to an individual array element via pointer makes sense only if the representation of such an element is the same as it would be for an individual value of the same type. Representation of array elements of type

scalar or *packed value* is implementation dependent; the above functions shall return `NULL` if the representation of the array elements differs from the representation of individual values of the same type.

H.12.5 Access to elements via canonical representation

This group of functions is meant for accessing elements that are packed arrays (bit or logic).

The following functions copy a whole packed array (a single vector) from a canonical representation to an element of an open array or they copy in the other direction. The actual argument's original SystemVerilog ranges are used to index the open array. The user is responsible for ensuring that the canonical representation has an adequate size for the copy operation.

```
/* functions for translation between simulator and canonical representations*/
/* s=source, d=destination */

/* From user space into simulator storage */
void svPutBitArrElemVecVal(const svOpenArrayHandle d, const svBitVecVal* s,
    int indx1, ...);
void svPutBitArrElem1VecVal(const svOpenArrayHandle d, const svBitVecVal* s,
    int indx1);
void svPutBitArrElem2VecVal(const svOpenArrayHandle d, const svBitVecVal* s,
    int indx1, int indx2);
void svPutBitArrElem3VecVal(const svOpenArrayHandle d, const svBitVecVal* s,
    int indx1, int indx2, int indx3);
void svPutLogicArrElemVecVal(const svOpenArrayHandle d, const svLogicVecVal* s,
    int indx1, ...);
void svPutLogicArrElem1VecVal(const svOpenArrayHandle d, const svLogicVecVal* s,
    int indx1);
void svPutLogicArrElem2VecVal(const svOpenArrayHandle d, const svLogicVecVal* s,
    int indx1, int indx2);
void svPutLogicArrElem3VecVal(const svOpenArrayHandle d, const svLogicVecVal* s,
    int indx1, int indx2, int indx3);

/* From simulator storage into user space */
void svGetBitArrElemVecVal(svBitVecVal* d, const svOpenArrayHandle s,
    int indx1, ...);
void svGetBitArrElem1VecVal(svBitVecVal* d, const svOpenArrayHandle s,
    int indx1);
void svGetBitArrElem2VecVal(svBitVecVal* d, const svOpenArrayHandle s,
    int indx1, int indx2);
void svGetBitArrElem3VecVal(svBitVecVal* d, const svOpenArrayHandle s,
    int indx1, int indx2, int indx3);
void svGetLogicArrElemVecVal(svLogicVecVal* d, const svOpenArrayHandle s,
    int indx1, ...);
void svGetLogicArrElem1VecVal(svLogicVecVal* d, const svOpenArrayHandle s,
    int indx1);
void svGetLogicArrElem2VecVal(svLogicVecVal* d, const svOpenArrayHandle s,
    int indx1, int indx2);
void svGetLogicArrElem3VecVal(svLogicVecVal* d, const svOpenArrayHandle s,
    int indx1, int indx2, int indx3);
```

H.12.6 Access to scalar elements (bit and logic)

Another group of functions is needed for scalars (i.e., when an element of an array is a simple scalar, **bit**, or **logic**):

```
svBit svGetBitArrElem (const svOpenArrayHandle s, int indx1, ...);
svBit svGetBitArrElem1(const svOpenArrayHandle s, int indx1);
```

```

svBit  svGetBitArrElem2(const svOpenArrayHandle s, int indx1, int indx2);
svBit  svGetBitArrElem3(const svOpenArrayHandle s, int indx1, int indx2,
                        int indx3);

svLogic svGetLogicArrElem (const svOpenArrayHandle s, int indx1, ...);
svLogic svGetLogicArrElem1(const svOpenArrayHandle s, int indx1);
svLogic svGetLogicArrElem2(const svOpenArrayHandle s, int indx1, int indx2);
svLogic svGetLogicArrElem3(const svOpenArrayHandle s, int indx1, int indx2,
                        int indx3);

void svPutLogicArrElem (const svOpenArrayHandle d, svLogic value, int indx1,
                        ...);
void svPutLogicArrElem1(const svOpenArrayHandle d, svLogic value, int indx1);
void svPutLogicArrElem2(const svOpenArrayHandle d, svLogic value, int indx1,
                        int indx2);
void svPutLogicArrElem3(const svOpenArrayHandle d, svLogic value, int indx1,
                        int indx2, int indx3);

void svPutBitArrElem (const svOpenArrayHandle d, svBit value, int indx1, ...);
void svPutBitArrElem1(const svOpenArrayHandle d, svBit value, int indx1);
void svPutBitArrElem2(const svOpenArrayHandle d, svBit value, int indx1,
                        int indx2);
void svPutBitArrElem3(const svOpenArrayHandle d, svBit value, int indx1,
                        int indx2, int indx3);

```

H.12.7 Access to array elements of other types

If an array's elements are of a type compatible with C, there is no need to use canonical representation. In such situations, the elements are accessed via pointers, i.e., the actual address of an element shall be computed first and then used to access the desired element.

H.12.8 Example 6—Two-dimensional open array

SystemVerilog:

```

typedef struct {int i; ... } MyType;

import "DPI-C" function void f1(input MyType i [][]);
    /* 2-dimensional unsized unpacked array of MyType */

MyType a_10x5 [11:20][6:2];
MyType a_64x8 [64:1][-1:-8];

f1(a_10x5);
f1(a_64x8);

```

C:

```

#include "svdpi.h"

typedef struct {int i; ... } MyType;

void f1(const svOpenArrayHandle h)
{
    MyType my_value;
    int i, j;
    int lo1 = svLow(h, 1);

```

```

int hi1 = svHigh(h, 1);
int lo2 = svLow(h, 2);
int hi2 = svHigh(h, 2);

for (i = lo1; i <= hi1; i++) {
    for (j = lo2; j <= hi2; j++) {

        my_value = *(MyType *)svGetArrElemPtr2(h, i, j);
        ...
        *(MyType *)svGetArrElemPtr2(h, i, j) = my_value;
        ...
    }
    ...
}
}

```

H.12.9 Example 7—Open array

SystemVerilog:

```

typedef struct { ... } MyType;

import "DPI-C" function void f1(input MyType i [], output MyType o []);

MyType source [11:20];
MyType target [11:20];

f1(source, target);

```

C:

```

#include "svdpi.h"

typedef struct ... } MyType;

void f1(const svOpenArrayHandle hin, const svOpenArrayHandle hout)
{
    int count = svSize(hin, 1);
    MyType *s = (MyType *)svGetArrayPtr(hin);
    MyType *d = (MyType *)svGetArrayPtr(hout);

    if (s && d) { /* both arrays have C layout */

        /* an efficient solution using pointer arithmetic */
        while (count--)
            *d++ = *s++;

        /* even more efficient:
        memcpy(d, s, svSizeOfArray(hin));
        */

    } else { /* less efficient yet implementation independent */

        int i = svLow(hin, 1);
        int j = svLow(hout, 1);
        while (i <= svHigh(hin, 1)) {
            *(MyType *)svGetArrElemPtr1(hout, j++) =

```

```
        *(MyType *)svGetArrElemPtr1(hin, i++);
    }

}

}
```

H.12.10 Example 8—Access to packed arrays

SystemVerilog:

```
import "DPI-C" function void f1(input logic [127:0]);
import "DPI-C" function void f2(input logic [127:0] i []); // open array of
// 128-bit
```

C:

```
#include "svdpi.h"

/* Copy out one 128-bit packed vector */
void f1(const svLogicVecVal* packed_vec_128_bit)
{
    svLogicVecVal arr[SV_PACKED_DATA_NELEMS(128)]; /* canonical rep */
    memcpy(arr, packed_vec_128_bit, sizeof(arr));
    ...
}

* Copy out each word of an open array of 128-bit packed vectors */
void f2(const svOpenArrayHandle h)
{
    int i;
    svLogicVecVal arr[SV_PACKED_DATA_NELEMS(128)]; /* canonical rep */
    for (i = svLow(h, 1); i <= svHigh(h, 1); i++) {
        const svLogicVecVal* ptr = (svLogicVecVal*)svGetArrElemPtr1(h, i);
        memcpy(arr, ptr, sizeof(arr));
        ...
    }
    ...
}
```

H.13 SV3.1a-compatible access to packed data (deprecated functionality)

The functionality described in this subclause is deprecated and need not be implemented by an IEEE 1800 simulator. The functionality provides backwards compatibility with Accellera SystemVerilog 3.1a (SV3.1a) [\[B3\]](#) regarding the semantics of packed array arguments. This subclause will describe the SV3.1a semantics.

The main difference between SV3.1a and IEEE 1800 semantics is that in SV3.1a, packed data arguments are passed by opaque handle types `svLogicPackedArrRef` and `svBitPackedArrRef`. An implementation need not do any conversion or marshalling of data into the canonical format. The C programmer is provided a set of utility functions that copies data between actual vendor format and canonical format. Other utilities are provided that put and get bit-selects and part-selects from actual vendor representation.

H.13.1 Determining the compatibility level of an implementation

Function `svDpiVersion()` is provided to allow the determination of an implementation's support for this standard. In simulators that only support the SV3.1a standard, users must make use of the opaque handle types for all 2-state and 4-state arguments. See [H.10.1.3](#).

When using an IEEE 1800 implementation, it is possible for users to make use of SV3.1a-compatible semantics on a per-function basis. Import and export declarations annotated with the "DPI" syntax shall yield the SV3.1a argument passing semantics on the C side of the interface. Import and export declarations annotated with the "DPI-C" syntax shall yield the IEEE 1800 argument passing semantics. See [35.4](#) and [35.5.4](#).

The `svdpi.h` file may contain definitions and function prototypes for use with SV3.1a-compliant packed data access. IEEE 1800 implementations are not obligated to provide these definitions and prototypes in the include file.

If an IEEE 1800 implementation does not support the functionality in this subclause, it is possible that the DPI C code may not successfully bind to the implementation.

H.13.2 svdpi.h definitions for SV3.1a-style packed data processing

The following definitions are used to define SV3.1a-style canonical access to packed data:

```
/* 2-state and 4-state vectors, modeled upon PLI's avalue/bvalue */
#define SV_CANONICAL_SIZE(WIDTH) (((WIDTH)+31)>>5)

typedef uint32_t
    svBitVec32; /* (a chunk of) packed bit array */

typedef struct { unsigned int c; unsigned int d;}
    svLogicVec32; /* (a chunk of) packed logic array */
```

The following definitions describe implementation-dependent packed data representation:

```
/* reference to a standalone packed array */
typedef void* svBitPackedArrRef;
typedef void* svLogicPackedArrRef;

/* total size in bytes of the simulator's representation of a packed array */
/* width in bits */
int svSizeOfBitPackedArr(int width);

int svSizeOfLogicPackedArr(int width);
```

The following functions provide translation between actual vendor representation and canonical representation. The functions copy the whole array in either direction. The user is responsible for providing the correct width and for allocating an array in the canonical representation. The contents of the unused bits are undetermined.

Although the put and get functionality provided for `bit` and `logic` packed arrays is sufficient, yet basic, it requires unnecessary copying of the whole packed array when perhaps only some bits are needed. For the sake of convenience and improved performance, bit-selects and limited (up to 32 bits) part-selects are also supported.

```
/* s=source, d=destination, w=width */
/* actual <-- canonical */
```

```
void svPutBitVec32 (svBitPackedArrRef d, const svBitVec32* s, int w);
void svPutLogicVec32 (svLogicPackedArrRef d, const svLogicVec32* s, int w);

/* canonical <-- actual */
void svGetBitVec32 (svBitVec32* d, const svBitPackedArrRef s, int w);
void svGetLogicVec32 (svLogicVec32* d, const svLogicPackedArrRef s, int w);
```

The following functions provide support for bit-select processing on actual vendor data representation:

```
/* Packed arrays are assumed to be indexed n-1:0, where 0 is the index of
   LSB */
/* functions for bit-select */
/* s=source, i=bit-index */
svBit svGetSelectBit(const svBitPackedArrRef s, int i);
svLogic svGetSelectLogic(const svLogicPackedArrRef s, int i);

/* d=destination, i=bit-index, s=scalar */
void svPutSelectBit(svBitPackedArrRef d, int i, svBit s);
void svPutSelectLogic(svLogicPackedArrRef d, int i, svLogic s);
```

Limited (up to 32-bit) part-selects are supported. A part-select is a slice of a packed array of types **bit** or **logic**. Array slices are not supported for unpacked arrays. Functions for part-selects only allow access (read/write) to a narrow subrange of up to 32 bits. Canonical representation shall be used for such narrow vectors. If the specified range of a part-select is not fully contained within the normalized range of an array, the behavior is undetermined.

```
/*
 * functions for part-select
 *
 * a narrow (<=32 bits) part-select is copied between
 * the implementation representation and a single chunk of
 * canonical representation
 * Normalized ranges and indexing [n-1:0] are used for both arrays:
 * the array in the implementation representation and the canonical array.
 *
 * s=source, d=destination, i=starting bit index, w=width
 * like for variable part-selects; limitations: w <= 32
 *
 * In part-select operations, the data are copied to or from the
 * canonical representation part ('chunk') designated by range [w-1:0]
 * and the implementation representation part designated by range [w+i-1:i].
 */

/* canonical <-- actual */
void svGetPartSelectBit(svBitVec32* d, const svBitPackedArrRef s, int i,
    int w);
svBitVec32 svGetBits(const svBitPackedArrRef s, int i, int w);
svBitVec32 svGet32Bits(const svBitPackedArrRef s, int i); // 32-bits
uint64_t svGet64Bits(const svBitPackedArrRef s, int i); // 64-bits
void svGetPartSelectLogic(svLogicVec32* d, const svLogicPackedArrRef s, int i,
    int w);

/* actual <-- canonical */
void svPutPartSelectBit(svBitPackedArrRef d, const svBitVec32 s, int i,
    int w);
void svPutPartSelectLogic(svLogicPackedArrRef d, const svLogicVec32 s, int i,
    int w);
```

H.13.3 Source-level compatibility include file svdpi_src.h

Only two symbols are defined: the macros that allow declaring variables to represent the SystemVerilog packed arrays of type `bit` or `logic`. Applications that do not need this file to compile are deemed binary-compatible. In other words, the DPI C code does not need to be recompiled to run on different simulators. Applications that make use of `svdpi_src.h` must be recompiled for each simulator on which they are to be run.

```
#define SV_BIT_PACKED_ARRAY(WIDTH,NAME) ...
#define SV_LOGIC_PACKED_ARRAY(WIDTH,NAME) ...
```

The actual definitions are implementation-specific, but shall not define an array type (see definition in 6.2.5 in ISO 9899:1999 [B2]). For example, a SystemVerilog simulator might define the latter macro as follows:

```
#define SV_LOGIC_PACKED_ARRAY(WIDTH,NAME) \
    struct { svLogicVec32 __unnamed [SV_CANONICAL_SIZE(WIDTH)]; } NAME
```

H.13.4 Example 9—Deprecated SV3.1a binary compatible application

SystemVerilog:

```
typedef struct {int x; int y;} pair;
import "DPI" function void f1(input int i1, pair i2, output logic [63:0] o3);

export "DPI" function exported_sv_func;

function void exported_sv_func(input int i, output int o [0:7]);
    begin ... end
endfunction
```

C:

```
include "svdpi.h"
typedef struct {int x; int y;} pair;
extern void exported_sv_func(int, int *); /* imported from SystemVerilog */
void f1(const int i1, const pair *i2, svLogicPackedArrRef* o3)
{
    svLogicVec32 arr[SV_CANONICAL_SIZE(64)]; /* 2 chunks needed */
    int tab[8];
    printf("%d\n", i1);
    arr[0].c = i2->x;
    arr[0].d = 0;
    arr[1].c = i2->y;
    arr[1].d = 0;
    svPutLogicVec32(o3, arr, 64);

    /* call SystemVerilog */
    exported_sv_func(i1, tab); /* tab passed by reference */
    ...
}
```

H.13.5 Example 10—Deprecated SV3.1a source compatible application

SystemVerilog:

```
typedef struct {int a; bit [6:1][1:8] b [65:2]; int c;} triple;
// troublesome mix of C types and packed arrays
import "DPI" function void f1(input triple t);

export "DPI" function exported_sv_func;

function void exported_sv_func(input int i, output logic [63:0] o);
    begin ... end
endfunction
```

C:

```
#include "svdpi.h"
#include "svdpi_src.h"

typedef struct {
    int a;
    SV_BIT_PACKED_ARRAY(6*8, b) [64]; /* implementation-specific
                                       representation */
    int c;
} triple;
/* Note that 'b' is defined as for 'bit [6*8-1:0] b [63:0]' */

extern void exported_sv_func(int, svLogicPackedArrRef); /* imported from
                                                         SystemVerilog */

void f1(const triple *t)
{
    int j;
    /* canonical representation */
    svBitVec32 aB[SV_CANONICAL_SIZE(6*8)]; /* 6*8 packed bits */
    svLogicVec32 aL[SV_CANONICAL_SIZE(64)];

    /* implementation-specific representation */
    SV_LOGIC_PACKED_ARRAY(64, my_tab);

    printf("%d %d\n", t->a, t->c);
    for (i = 0; i < 64; i++) {
        svGetBitVec32(aB, (svBitPackedArrRef)&(t->b[i]), 6*8);
        ...
    }
    ...
    /* call SystemVerilog */
    exported_sv_func(2, (svLogicPackedArrRef)&my_tab); /* by reference */
    svGetLogicVec32(aL, (svLogicPackedArrRef)&my_tab, 64);
    ...
}
```

H.13.6 Example 11—Deprecated SV3.1a binary compatible calls of export functions

This example demonstrates that the source compatibility include file `svdpi_src.h` is not needed if a C function dynamically allocates the data structure for simulator representation of a packed array to be passed to an exported SystemVerilog function.

SystemVerilog:

```
export "DPI" function myfunc;  
...  
function void myfunc (output logic [31:0] r); ...  
...
```

C:

```
#include "svdpi.h"  
extern void myfunc (svLogicPackedArrRef r); /* exported from SV */  
  
/* output logic packed 32-bits */  
...  
svLogicVec32 my_r[SV_CANONICAL_SIZE(32)];  
/* my array, canonical representation */  
  
/* allocate memory for logic packed 32-bits in simulator's representation */  
svLogicPackedArrRef r =  
    (svLogicPackedArrRef)malloc(svSizeOfLogicPackedArr(32));  
myfunc(r);  
/* canonical <-- actual */  
svGetLogicVec32(my_r, r, 32);  
/* shall use only the canonical representation from now on */  
free(r); /* do not need any more */  
...
```

Annex I

(normative)

svdpi.h

I.1 General

This annex lists the contents of the `svdpi.h` include file.

I.2 Overview

This is a normative include file that shall be provided by all SystemVerilog simulators. However, there is deprecated functionality at the bottom of the file that need not be provided. This functionality is clearly delimited by comments in the file.

Implementations shall define the types `uint8_t` and `uint32_t`, but the exact method of doing so is not prescribed by this standard. The section in the include file shown below is a suggested way of defining `uint8_t` and `uint32_t` for a wide variety of SystemVerilog platforms.

I.3 Source code

```
/*
 * svdpi.h
 *
 * SystemVerilog Direct Programming Interface (DPI).
 *
 * This file contains the constant definitions, structure definitions,
 * and routine declarations used by SystemVerilog DPI.
 */

#ifndef INCLUDED_SVDPI
#define INCLUDED_SVDPI

#ifdef __cplusplus
extern "C" {
#endif

/* Define size-critical types on all OS platforms. */
#ifdef _MSC_VER
typedef unsigned __int64 uint64_t;
typedef unsigned __int32 uint32_t;
typedef unsigned __int8 uint8_t;
typedef signed __int64 int64_t;
typedef signed __int32 int32_t;
typedef signed __int8 int8_t;
#elif defined(__MINGW32__)
#include <stdint.h>
#elif defined(__linux)
#include <inttypes.h>
#else
#include <sys/types.h>
#endif
#endif
```

```
/* Use to export a symbol from application */
#if defined (_MSC_VER)
#define DPI_DLLISPEC __declspec(dllimport)
#else
#define DPI_DLLISPEC
#endif

/* Use to import a symbol into application */
#if defined (_MSC_VER)
#define DPI_DLLESPEC __declspec(dllexport)
#else
#define DPI_DLLESPEC
#endif

/* Use to mark a function as external */
#ifndef DPI_EXTERN
#define DPI_EXTERN
#endif

#ifndef DPI_PROTOTYPES
#define DPI_PROTOTYPES
/* object is defined imported by the application */
#define XXTERN DPI_EXTERN DPI_DLLISPEC
/* object is exported by the application */
#define EETERN DPI_EXTERN DPI_DLLESPEC
#endif

/* canonical representation */
#define sv_0 0
#define sv_1 1
#define sv_z 2
#define sv_x 3

/* common type for 'bit' and 'logic' scalars. */
typedef uint8_t svScalar;
typedef svScalar svBit; /* scalar */
typedef svScalar svLogic; /* scalar */

/*
 * DPI representation of packed arrays.
 * 2-state and 4-state vectors, exactly the same as PLI's avalue/bvalue.
 */
#ifndef VPI_VECVAL
#define VPI_VECVAL
typedef struct t_vpi_vecval {
    uint32_t aval;
    uint32_t bval;
} s_vpi_vecval, *p_vpi_vecval;
#endif

/* (a chunk of) packed logic array */
typedef s_vpi_vecval svLogicVecVal;

/* (a chunk of) packed bit array */
typedef uint32_t svBitVecVal;

/* Number of chunks required to represent the given width packed array */
```

```
#define SV_PACKED_DATA_NELEMS(WIDTH) (((WIDTH) + 31) >> 5)

/*
 * Because the contents of the unused bits is undetermined,
 * the following macros can be handy.
 */
#define SV_MASK(N) (~(-1 << (N)))

#define SV_GET_UNSIGNED_BITS(VALUE, N) \
    ((N) == 32 ? (VALUE) : ((VALUE) & SV_MASK(N)))

#define SV_GET_SIGNED_BITS(VALUE, N) \
    ((N) == 32 ? (VALUE) : \
    (((VALUE) & (1 << (N))) ? ((VALUE) | ~SV_MASK(N)) : ((VALUE) & SV_MASK(N))))

/*
 * Implementation-dependent representation.
 */
/*
 * Return implementation version information string ("1800-2005" or "SV3.1a").
 */
XXTERN const char* svDpiVersion();

/* a handle to a scope (an instance of a module or interface) */
XXTERN typedef void* svScope;

/* a handle to a generic object (actually, unsized array) */
XXTERN typedef void* svOpenArrayHandle;

/*
 * Bit-select utility functions.
 *
 * Packed arrays are assumed to be indexed n-1:0,
 * where 0 is the index of LSB
 */

/* s=source, i=bit-index */
XXTERN svBit svGetBitselBit(const svBitVecVal* s, int i);
XXTERN svLogic svGetBitselLogic(const svLogicVecVal* s, int i);

/* d=destination, i=bit-index, s=scalar */
XXTERN void svPutBitselBit(svBitVecVal* d, int i, svBit s);
XXTERN void svPutBitselLogic(svLogicVecVal* d, int i, svLogic s);

/*
 * Part-select utility functions.
 *
 * A narrow (<=32 bits) part-select is extracted from the
 * source representation and written into the destination word.
 *
 * Normalized ranges and indexing [n-1:0] are used for both arrays.
 *
 * s=source, d=destination, i=starting bit index, w=width
 * like for variable part-selects; limitations: w <= 32
 */
XXTERN void svGetPartselBit(svBitVecVal* d, const svBitVecVal* s, int i, int w);
XXTERN void svGetPartselLogic(svLogicVecVal* d, const svLogicVecVal* s, int i, int
w);
```

```
XXTERN void svPutPartselBit(svBitVecVal* d, const svBitVecVal s, int i, int w);
XXTERN void svPutPartselLogic(svLogicVecVal* d, const svLogicVecVal s, int i, int w);

/*
 * Open array querying functions
 * These functions are modeled upon the SystemVerilog array
 * querying functions and use the same semantics.
 *
 * If the dimension is 0, then the query refers to the
 * packed part of an array (which is one-dimensional).
 * Dimensions > 0 refer to the unpacked part of an array.
 */
/* h= handle to open array, d=dimension */
XXTERN int svLeft(const svOpenArrayHandle h, int d);
XXTERN int svRight(const svOpenArrayHandle h, int d);
XXTERN int svLow(const svOpenArrayHandle h, int d);
XXTERN int svHigh(const svOpenArrayHandle h, int d);
XXTERN int svIncrement(const svOpenArrayHandle h, int d);
XXTERN int svSize(const svOpenArrayHandle h, int d);
XXTERN int svDimensions(const svOpenArrayHandle h);

/*
 * Pointer to the actual representation of the whole array of any type
 * NULL if not in C layout
 */
XXTERN void *svGetArrayPtr(const svOpenArrayHandle);

/* total size in bytes or 0 if not in C layout */
XXTERN int svSizeOfArray(const svOpenArrayHandle);

/*
 * Return a pointer to an element of the array
 * or NULL if index outside the range or null pointer
 */
XXTERN void *svGetArrElemPtr(const svOpenArrayHandle, int indx1, ...);

/* specialized versions for 1-, 2- and 3-dimensional arrays: */
XXTERN void *svGetArrElemPtr1(const svOpenArrayHandle, int indx1);
XXTERN void *svGetArrElemPtr2(const svOpenArrayHandle, int indx1, int indx2);
XXTERN void *svGetArrElemPtr3(const svOpenArrayHandle, int indx1, int indx2,
                               int indx3);

/*
 * Functions for copying between simulator storage and user space.
 * These functions copy the whole packed array in either direction.
 * The user is responsible for allocating an array to hold the
 * canonical representation.
 */

/* s=source, d=destination */
/* From user space into simulator storage */
XXTERN void svPutBitArrElemVecVal(const svOpenArrayHandle d, const svBitVecVal* s,
                                   int indx1, ...);
XXTERN void svPutBitArrElem1VecVal(const svOpenArrayHandle d, const svBitVecVal* s,
                                    int indx1);
XXTERN void svPutBitArrElem2VecVal(const svOpenArrayHandle d, const svBitVecVal* s,
                                    int indx1, int indx2);
XXTERN void svPutBitArrElem3VecVal(const svOpenArrayHandle d, const svBitVecVal* s,
                                    int indx1, int indx2, int indx3);
```

```
XXTERN void svPutLogicArrElemVecVal(const svOpenArrayHandle d, const svLogicVecVal*
s,
    int indx1, ...);
XXTERN void svPutLogicArrElem1VecVal(const svOpenArrayHandle d, const svLogicVecVal*
s,
    int indx1);
XXTERN void svPutLogicArrElem2VecVal(const svOpenArrayHandle d, const svLogicVecVal*
s,
    int indx1, int indx2);
XXTERN void svPutLogicArrElem3VecVal(const svOpenArrayHandle d, const svLogicVecVal*
s,
    int indx1, int indx2, int indx3);

/* From simulator storage into user space */
XXTERN void svGetBitArrElemVecVal(svBitVecVal* d, const svOpenArrayHandle s,
    int indx1, ...);
XXTERN void svGetBitArrElem1VecVal(svBitVecVal* d, const svOpenArrayHandle s,
    int indx1);
XXTERN void svGetBitArrElem2VecVal(svBitVecVal* d, const svOpenArrayHandle s,
    int indx1, int indx2);
XXTERN void svGetBitArrElem3VecVal(svBitVecVal* d, const svOpenArrayHandle s,
    int indx1, int indx2, int indx3);
XXTERN void svGetLogicArrElemVecVal(svLogicVecVal* d, const svOpenArrayHandle s,
    int indx1, ...);
XXTERN void svGetLogicArrElem1VecVal(svLogicVecVal* d, const svOpenArrayHandle s,
    int indx1);
XXTERN void svGetLogicArrElem2VecVal(svLogicVecVal* d, const svOpenArrayHandle s,
    int indx1, int indx2);
XXTERN void svGetLogicArrElem3VecVal(svLogicVecVal* d, const svOpenArrayHandle s,
    int indx1, int indx2, int indx3);

XXTERN svBit svGetBitArrElem(const svOpenArrayHandle s, int indx1, ...);
XXTERN svBit svGetBitArrElem1(const svOpenArrayHandle s, int indx1);
XXTERN svBit svGetBitArrElem2(const svOpenArrayHandle s, int indx1, int indx2);
XXTERN svBit svGetBitArrElem3(const svOpenArrayHandle s, int indx1, int indx2,
    int indx3);
XXTERN svLogic svGetLogicArrElem(const svOpenArrayHandle s, int indx1, ...);
XXTERN svLogic svGetLogicArrElem1(const svOpenArrayHandle s, int indx1);
XXTERN svLogic svGetLogicArrElem2(const svOpenArrayHandle s, int indx1, int indx2);
XXTERN svLogic svGetLogicArrElem3(const svOpenArrayHandle s, int indx1, int indx2,
    int indx3);
XXTERN void svPutLogicArrElem(const svOpenArrayHandle d, svLogic value, int indx1,
    ...);
XXTERN void svPutLogicArrElem1(const svOpenArrayHandle d, svLogic value, int indx1);
XXTERN void svPutLogicArrElem2(const svOpenArrayHandle d, svLogic value, int indx1,
    int indx2);
XXTERN void svPutLogicArrElem3(const svOpenArrayHandle d, svLogic value, int indx1,
    int indx2, int indx3);
XXTERN void svPutBitArrElem(const svOpenArrayHandle d, svBit value, int indx1, ...);
XXTERN void svPutBitArrElem1(const svOpenArrayHandle d, svBit value, int indx1);
XXTERN void svPutBitArrElem2(const svOpenArrayHandle d, svBit value, int indx1,
    int indx2);
XXTERN void svPutBitArrElem3(const svOpenArrayHandle d, svBit value, int indx1,
    int indx2, int indx3);

/* Functions for working with DPI context */

/*
```



```
* Retrieve the active instance scope currently associated with the executing
* imported function. Unless a prior call to svSetScope has occurred, this
* is the scope of the function's declaration site, not call site.
* Returns NULL if called from C code that is *not* an imported function.
*/
XXTERN svScope svGetScope();

/*
* Set context for subsequent export function execution.
* This function must be called before calling an export function, unless
* the export function is called while executing an import function. In that
* case the export function shall inherit the scope of the surrounding import
* function. This is known as the "default scope".
* The return is the previous active scope (per svGetScope)
*/
XXTERN svScope svSetScope(const svScope scope);

/* Gets the fully qualified name of a scope handle */
XXTERN const char* svGetNameFromScope(const svScope);

/*
* Retrieve svScope to instance scope of an arbitrary function declaration.
* (can be either module, program, interface, or generate scope)
* The return value shall be NULL for unrecognized scope names.
*/
XXTERN svScope svGetScopeFromName(const char* scopeName);

/*
* Store an arbitrary user data pointer for later retrieval by svGetUserData()
* The userKey is generated by the user. It must be guaranteed by the user to
* be unique from all other userKey's for all unique data storage requirements
* It is recommended that the address of static functions or variables in the
* user's C code be used as the userKey.
* It is illegal to pass in NULL values for either the scope or userData
* arguments. It is also an error to call svPutUserData() with an invalid
* svScope. This function returns -1 for all error cases, 0 upon success. It is
* suggested that userData values of 0 (NULL) not be used as otherwise it can
* be impossible to discern error status returns when calling svGetUserData()
*/
XXTERN int svPutUserData(const svScope scope, void *userKey, void* userData);

/*
* Retrieve an arbitrary user data pointer that was previously
* stored by a call to svPutUserData(). See the comment above
* svPutUserData() for an explanation of userKey, as well as
* restrictions on NULL and illegal svScope and userKey values.
* This function returns NULL for all error cases, 0 upon success.
* This function also returns NULL in the event that a prior call
* to svPutUserData() was never made.
*/
XXTERN void* svGetUserData(const svScope scope, void* userKey);

/*
* Returns the file and line number in the SV code from which the import call
* was made. If this information available, returns TRUE and updates fileName
* and lineNumber to the appropriate values. Behavior is unpredictable if
* fileName or lineNumber are not appropriate pointers. If this information is
* not available return FALSE and contents of fileName and lineNumber not
* modified. Whether this information is available or not is implementation-
* specific. Note that the string provided (if any) is owned by the SV
* implementation and is valid only until the next call to any SV function.
```

```
* Applications must not modify this string or free it
*/
XXTERN int svGetCallerInfo(const char** fileName, int *lineNumber);

/*
 * Returns 1 if the current execution thread is in the disabled state.
 * Disable protocol must be adhered to if in the disabled state.
 */
XXTERN int svIsDisabledState();

/*
 * Imported functions call this API function during disable processing to
 * acknowledge that they are correctly participating in the DPI disable protocol.
 * This function must be called before returning from an imported function that is
 * in the disabled state.
 */
XXTERN void svAckDisabledState();

/*
*****
 * DEPRECATED PORTION OF FILE STARTS FROM HERE.
 * IEEE-1800-compliant tools may not provide
 * support for the following functionality.
*****
 */

/*
 * Canonical representation of packed arrays
 * 2-state and 4-state vectors, modeled upon PLI's avalue/bvalue
 */
#define SV_CANONICAL_SIZE(WIDTH) (((WIDTH)+31)>>5)
typedef unsigned int svBitVec32; /* (a chunk of) packed bit array */
typedef struct { unsigned int c; unsigned int d;}
svLogicVec32; /* (a chunk of) packed logic array */

/* reference to a standalone packed array */
typedef void* svBitPackedArrRef;
typedef void* svLogicPackedArrRef;

/*
 * total size in bytes of the simulator's representation of a packed array
 * width in bits
 */
XXTERN int svSizeOfBitPackedArr(int width);
XXTERN int svSizeOfLogicPackedArr(int width);

/* Translation between the actual representation and the canonical representation */

/* s=source, d=destination, w=width */
/* actual <-- canonical */
XXTERN void svPutBitVec32(svBitPackedArrRef d, const svBitVec32* s, int w);
XXTERN void svPutLogicVec32(svLogicPackedArrRef d, const svLogicVec32* s, int w);

/* canonical <-- actual */
XXTERN void svGetBitVec32(svBitVec32* d, const svBitPackedArrRef s, int w);
XXTERN void svGetLogicVec32(svLogicVec32* d, const svLogicPackedArrRef s, int w);

/*
 * Bit-select functions

```

```
* Packed arrays are assumed to be indexed n-1:0,
* where 0 is the index of LSB
*/

/* s=source, i=bit-index */
XXTERN svBit svGetSelectBit(const svBitPackedArrRef s, int i);
XXTERN svLogic svGetSelectLogic(const svLogicPackedArrRef s, int i);

/* d=destination, i=bit-index, s=scalar */
XXTERN void svPutSelectBit(svBitPackedArrRef d, int i, svBit s);
XXTERN void svPutSelectLogic(svLogicPackedArrRef d, int i, svLogic s);

/*
* functions for part-select
*
* a narrow (<=32 bits) part-select is copied between
* the implementation representation and a single chunk of
* canonical representation
* Normalized ranges and indexing [n-1:0] are used for both arrays:
* the array in the implementation representation and the canonical array.
*
* s=source, d=destination, i=starting bit index, w=width
* like for variable part-selects; limitations: w <= 32
*/

/* canonical <-- actual */
XXTERN void svGetPartSelectBit(svBitVec32* d, const svBitPackedArrRef s,
    int i, int w);
XXTERN svBitVec32 svGetBits(const svBitPackedArrRef s, int i, int w);
XXTERN svBitVec32 svGet32Bits(const svBitPackedArrRef s, int i); /* 32-bits */

XXTERN uint64_t svGet64Bits(const svBitPackedArrRef s, int i);

/* 64-bits */
XXTERN void svGetPartSelectLogic(svLogicVec32* d, const svLogicPackedArrRef s,
    int i, int w);
/* actual <-- canonical */
XXTERN void svPutPartSelectBit(svBitPackedArrRef d, const svBitVec32 s,
    int i, int w);
XXTERN void svPutPartSelectLogic(svLogicPackedArrRef d, const svLogicVec32 s,
    int i, int w);

/*
* Functions for open array translation between simulator and canonical
* representations. These functions copy the whole packed array in either
* direction. The user is responsible for allocating an array in the
* canonical representation.
*/

/* s=source, d=destination */
/* actual <-- canonical */
XXTERN void svPutBitArrElemVec32(const svOpenArrayHandle d, const svBitVec32* s,
    int indx1, ...);
XXTERN void svPutBitArrElem1Vec32(const svOpenArrayHandle d, const svBitVec32* s,
    int indx1);
XXTERN void svPutBitArrElem2Vec32(const svOpenArrayHandle d, const svBitVec32* s,
    int indx1, int indx2);
XXTERN void svPutBitArrElem3Vec32(const svOpenArrayHandle d, const svBitVec32* s,
    int indx1, int indx2, int indx3);
XXTERN void svPutLogicArrElemVec32(const svOpenArrayHandle d, const svLogicVec32* s,
    int indx1, ...);
```

```
XXTERN void svPutLogicArrElem1Vec32(const svOpenArrayHandle d, const svLogicVec32* s,
    int indx1);
XXTERN void svPutLogicArrElem2Vec32(const svOpenArrayHandle d, const svLogicVec32* s,
    int indx1, int indx2);
XXTERN void svPutLogicArrElem3Vec32(const svOpenArrayHandle d, const svLogicVec32* s,
    int indx1, int indx2, int indx3);

/* canonical <-- actual */
XXTERN void svGetBitArrElemVec32(svBitVec32* d, const svOpenArrayHandle s,
    int indx1, ...);
XXTERN void svGetBitArrElem1Vec32(svBitVec32* d, const svOpenArrayHandle s,
    int indx1);
XXTERN void svGetBitArrElem2Vec32(svBitVec32* d, const svOpenArrayHandle s,
    int indx1, int indx2);
XXTERN void svGetBitArrElem3Vec32(svBitVec32* d, const svOpenArrayHandle s,
    int indx1, int indx2, int indx3);
XXTERN void svGetLogicArrElemVec32(svLogicVec32* d, const svOpenArrayHandle s,
    int indx1, ...);
XXTERN void svGetLogicArrElem1Vec32(svLogicVec32* d, const svOpenArrayHandle s,
    int indx1);
XXTERN void svGetLogicArrElem2Vec32(svLogicVec32* d, const svOpenArrayHandle s,
    int indx1, int indx2);
XXTERN void svGetLogicArrElem3Vec32(svLogicVec32* d, const svOpenArrayHandle s,
    int indx1, int indx2, int indx3);

/*
*****
* DEPRECATED PORTION OF FILE ENDS HERE.
*****
*/

#undef DPI_EXTERN

#ifdef DPI_PROTOTYPES
#undef DPI_PROTOTYPES
#undef XXTERN
#undef EETERN
#endif

#ifdef __cplusplus
}
#endif

#endif
```

Annex J

(normative)

Inclusion of foreign language code

J.1 General

This annex describes common guidelines for the inclusion of foreign language code into a SystemVerilog application. The intention of these guidelines is to enable the redistribution of C binaries in shared object form.

J.2 Overview

Foreign language code is functionality that is included into SystemVerilog using the DPI. As a result, all statements of this annex apply only to code included using this interface; code included by using other interfaces (e.g., VPI) is outside the scope of this standard. Due to the nature of the DPI, most foreign language code is usually created from C or C++ source code, although nothing precludes the creation of appropriate object code from other languages. This annex adheres to this rule: its content is independent from the actual language used.

In general, foreign language code is provided in the form of object code compiled for the actual platform. The capability to include foreign language code in object-code form shall be supported by all simulators as specified here.

This annex defines how to

- Specify the location of the corresponding files within the file system.
- Specify the files to be loaded (in case of object code).
- Provide the object code (as a shared library or archive).

Although this annex defines guidelines for a common inclusion methodology, it requires multiple implementations (usually two) of the corresponding facilities. This takes into account that multiple users can have different viewpoints and different requirements on the inclusion of foreign language code.

- A vendor that wants to provide its Intellectual Property (IP) in the form of foreign language code often requires a self-contained method for the integration, which still permits an integration by a third party. This use case is often covered by a bootstrap file approach.
- A project team that specifies a common, standard set of foreign language code might change the code depending on technology, selected cells, back-annotation data, and other items. This use case is often covered by a set of tool switches, although it might also use the bootstrap file approach.
- An user might want to switch between selections or provide additional code. This use case is covered by providing a set of tool switches to define the corresponding information, although it might also use the bootstrap file approach.

NOTE—This annex defines a set of switch names to be used for a particular functionality. This is of informative nature; the actual naming of switches is not part of this standard. Further, it might not be possible to use certain character configurations in all operating systems or shells. Therefore, any switch name defined within this standard is a recommendation on how to name a switch, but not a requirement of the language.

J.3 Location independence

All pathnames specified within this annex are intended to be location independent, which is accomplished by using the switch `-sv_root`. It can receive a single directory pathname as the value, which is then prepended to any relative pathname that has been specified. In absence of this switch, or when processing relative filenames before any `-sv_root` specification, the current working directory of the user shall be used as the default value.

J.4 Object code inclusion

Compiled object code is required for cases where the compilation and linking of source code are fully handled by the user; thus, the created object code only need be loaded to integrate the foreign language code into a SystemVerilog application. All SystemVerilog applications shall support the integration of foreign language code in object code form. [Figure J.1](#) depicts the inclusion of object code and its relations to the various steps involved in this integration process.

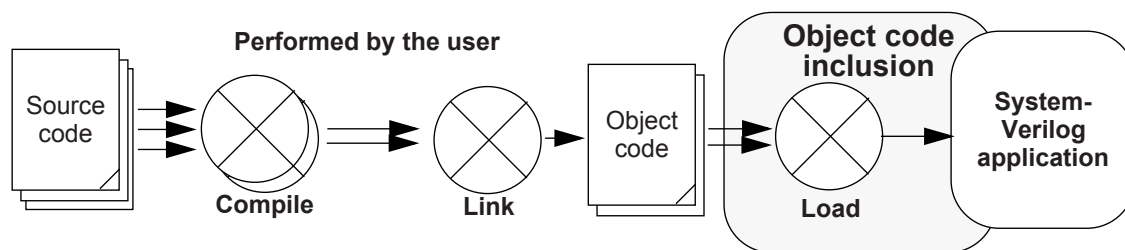

Figure J.1—Inclusion of object code into a SystemVerilog application

Compiled object code can be specified by one of the following two methods:

- By an entry in a bootstrap file; see [J.4.1](#) for more details on this file and its content. Its location shall be specified with one instance of the switch `-sv_liblist pathname`. This switch can be used multiple times to define the usage of multiple bootstrap files.
- By specifying the file with one instance of the switch `-sv_lib pathname_without_extension` (i.e., the filename shall be specified without the platform-specific extension). The SystemVerilog application is responsible for appending the appropriate extension for the actual platform. This switch can be used multiple times to define multiple libraries holding object code.

Both methods shall be provided and made available concurrently to permit any mixture of their usage. Every location can be an absolute pathname or a relative pathname, where the value of the switch `-sv_root` is used to identify an appropriate prefix for relative pathnames (see [J.3](#) for more details on forming pathnames).

The following conditions also apply.

- The compiled object code itself shall be provided in the form of a shared library having the appropriate extension for the actual platform.

NOTE—Shared libraries use, for example, `.so` for Solaris and `.sl` for HP-UX; other operating systems might use different extensions. In any case, the SystemVerilog application needs to identify the appropriate extension.

- The provider of the compiled code is responsible for any external references specified within these objects. Appropriate data need to be provided to resolve all open dependencies with the correct information.

- The provider of the compiled code shall avoid interferences with other software and select the appropriate software version (e.g., in cases where two versions of the same library are referenced). Similar problems can arise when there are dependencies on the expected run-time environment in the compiled object code (e.g., in cases where C++ global objects or static initializers are used).
- The SystemVerilog application need only load object code within a shared library that is referenced by the SystemVerilog code or by registration functions; loading of additional functions included within a shared library can interfere with other parts.

In the case of multiple occurrences of the same file (files having the same pathname or that can easily be identified as being identical, e.g., by comparing the inodes of the files to detect cases where links are used to refer the same file), the above order also identifies the precedence of loading. A file located by method a (above in this subclause) shall override files specified by method b.

All compiled object code needs to be loaded in the specification order similarly to the above scheme; first the content of the bootstrap file is processed starting with the first line, then the set of `-sv_lib` switches is processed in order of their occurrence. Any library shall only be loaded once.

J.4.1 Bootstrap file

The object code bootstrap file has the following syntax:

- a) The first line contains the string `#!SV_LIBRARIES`.
- b) An arbitrary amount of entries follow, one entry per line, where every entry holds exactly one library location. Each entry consists only of the *pathname_without_extension* of the object code file to be loaded and can be surrounded by an arbitrary number of blanks; at least one blank shall precede the entry in the line. The value *pathname_without_extension* is equivalent to the value of the switch `-sv_lib`.
- c) Any amount of comment lines can be interspersed between the entry lines; a comment line starts with the character `#` after an arbitrary (including zero) amount of blanks and is terminated with a newline.

J.4.2 Examples

- a) If the pathname root has been set by the switch `-sv_root` to `/home/user` and the following object files need to be included:

```
/home/user/myclibs/lib1.so  
/home/user/myclibs/lib3.so  
/home/user/proj1/clibs/lib4.so  
/home/user/proj3/clibs/lib2.so
```

then use either of the methods in [Figure J.2](#). Both methods are equivalent.

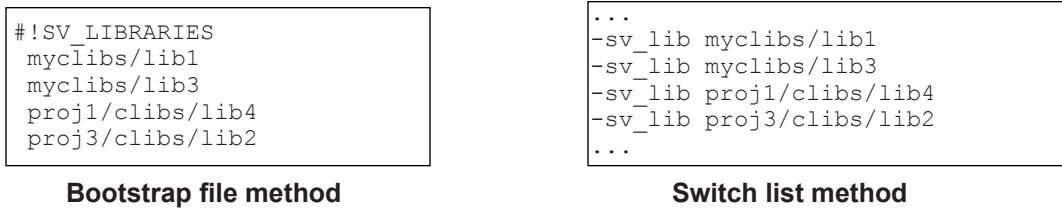

Figure J.2—Using a simple bootstrap file or a switch list

- b) If the current working directory is `/home/user`, using the series of switches shown in [Figure J.3](#) (left column) results in loading the following files (right column):

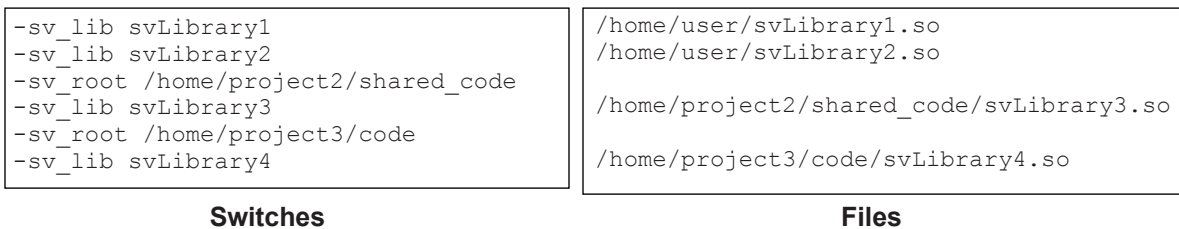

Figure J.3—Using a combination of `-sv_lib` and `-sv_root` switches

- c) Further, using the set of switches and contents of bootstrap files shown in [Figure J.4](#):

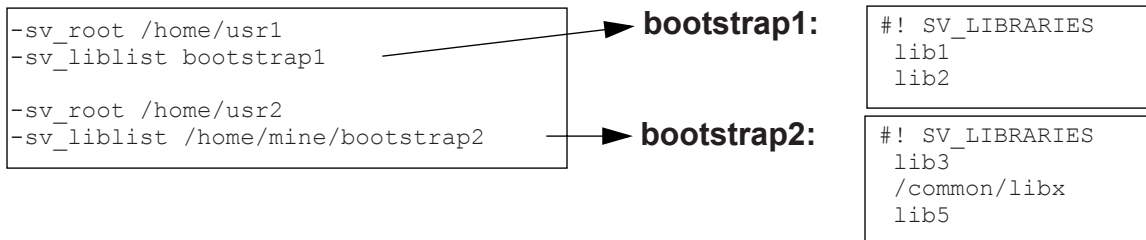

Figure J.4—Mixing `-sv_root` and bootstrap files

results in loading the following files:

```
/home/usr1/lib1.ext
/home/usr1/lib2.ext
/home/usr2/lib3.ext
/common/libx.ext
/home/usr2/lib5.ext
```

where *ext* stands for the actual extension of the corresponding file.

Annex K

(normative)

vpi_user.h

K.1 General

This annex shows the contents of the vpi_user.h include file. This is a normative include file that shall be provided by all SystemVerilog simulators.

K.2 Source code

```
/*
 * vpi_user.h
 *
 * IEEE Std 1800 Programming Language Interface (PLI)
 *
 * This file contains the constant definitions, structure definitions, and
 * routine declarations used by the SystemVerilog Verification Procedural
 * Interface (VPI) access routines.
 */
/*****

/*****
 * NOTE: the constant values 1 through 299 are reserved for use in this
 * vpi_user.h file.
 *****/

#ifndef VPI_USER_H
#define VPI_USER_H

#include <stdarg.h>

#ifdef __cplusplus
extern "C" {
#endif

/*-----*/
/*----- Portability Help -----*/
/*-----*/

/* Define size-critical types on all OS platforms. */
#if defined (_MSC_VER)
typedef unsigned __int64 uint64_t;
typedef unsigned __int32 uint32_t;
typedef unsigned __int8 uint8_t;
typedef signed __int64 int64_t;
typedef signed __int32 int32_t;
typedef signed __int8 int8_t;
#elif defined(_MINGW32_)
#include <stdint.h>
#elif defined(__linux)
#include <inttypes.h>
#else
#include <sys/types.h>
#endif

```

```
#endif

/* Sized variables */

#ifndef SVPI_TYPES
#define SVPI_TYPES
typedef int64_t PLI_INT64;
typedef uint64_t PLI_UINT64;
#endif

#ifndef PLI_TYPES
#define PLI_TYPES
typedef int          PLI_INT32;
typedef unsigned int PLI_UINT32;
typedef short       PLI_INT16;
typedef unsigned short PLI_UINT16;
typedef char        PLI_BYTE8;
typedef unsigned char PLI_UBYTE8;
#endif

/* Use to export a symbol */

#if WIN32
#ifndef PLI_DLLISPEC
#define PLI_DLLISPEC __declspec(dllimport)
#define VPI_USER_DEFINED_DLLISPEC 1
#endif
#else
#ifndef PLI_DLLISPEC
#define PLI_DLLISPEC
#endif
#endif

/* Use to import a symbol */

#if WIN32
#ifndef PLI_DLLESPEC
#define PLI_DLLESPEC __declspec(dllexport)
#define VPI_USER_DEFINED_DLLESPEC 1
#endif
#else
#ifndef PLI_DLLESPEC
#define PLI_DLLESPEC
#endif
#endif

/* Use to mark a function as external */

#ifndef PLI_EXTERN
#define PLI_EXTERN
#endif

/* Use to mark a variable as external */

#ifndef PLI_VEXTERN
#define PLI_VEXTERN extern
#endif

#ifndef PLI_PROTOTYPES
#define PLI_PROTOTYPES
#define PROTO_PARAMS(params) params

/* object is defined imported by the application */
```

```

#define XXTERN PLI_EXTERN PLI_DLLISPEC

/* object is exported by the application */

#define EEXTERN PLI_EXTERN PLI_DLLESPEC
#endif

/***** TYPEDEFS *****/

typedef PLI_UINT32 *vpiHandle;

/***** OBJECT TYPES *****/

#define vpiAlways 1 /* always procedure */
#define vpiAssignStmt 2 /* quasi-continuous assignment */
#define vpiAssignment 3 /* procedural assignment */
#define vpiBegin 4 /* block statement */
#define vpiCase 5 /* case statement */
#define vpiCaseItem 6 /* case statement item */
#define vpiConstant 7 /* numerical constant or string literal */
#define vpiContAssign 8 /* continuous assignment */
#define vpiDeassign 9 /* deassignment statement */
#define vpiDefParam 10 /* defparam */
#define vpiDelayControl 11 /* delay statement (e.g., #10) */
#define vpiDisable 12 /* named block disable statement */
#define vpiEventControl 13 /* wait on event, e.g., @e */
#define vpiEventStmt 14 /* event trigger, e.g., ->e */
#define vpiFor 15 /* for statement */
#define vpiForce 16 /* force statement */
#define vpiForever 17 /* forever statement */
#define vpiFork 18 /* fork-join block */
#define vpiFuncCall 19 /* function call */
#define vpiFunction 20 /* function */
#define vpiGate 21 /* primitive gate */
#define vpiIf 22 /* if statement */
#define vpiIfElse 23 /* if-else statement */
#define vpiInitial 24 /* initial procedure */
#define vpiIntegerVar 25 /* integer variable */
#define vpiInterModPath 26 /* intermodule wire delay */
#define vpiIterator 27 /* iterator */
#define vpiIODecl 28 /* input/output declaration */
#define vpiMemory 29 /* behavioral memory */
#define vpiMemoryWord 30 /* single word of memory */
#define vpiModPath 31 /* module path for path delays */
#define vpiModule 32 /* module instance */
#define vpiNamedBegin 33 /* named block statement */
#define vpiNamedEvent 34 /* event variable */
#define vpiNamedFork 35 /* named fork-join block */
#define vpiNet 36 /* scalar or vector net */
#define vpiNetBit 37 /* bit of vector net */
#define vpiNullStmt 38 /* a semicolon. Ie. #10 ; */
#define vpiOperation 39 /* behavioral operation */
#define vpiParamAssign 40 /* module parameter assignment */
#define vpiParameter 41 /* module parameter */
#define vpiPartSelect 42 /* part-select */
#define vpiPathTerm 43 /* terminal of module path */
#define vpiPort 44 /* module port */
#define vpiPortBit 45 /* bit of vector module port */
#define vpiPrimTerm 46 /* primitive terminal */
#define vpiRealVar 47 /* real variable */
#define vpiReg 48 /* scalar or vector reg */
#define vpiRegBit 49 /* bit of vector reg */
#define vpiRelease 50 /* release statement */
#define vpiRepeat 51 /* repeat statement */

```

```
#define vpiRepeatControl      52  /* repeat control in an assign stmt */
#define vpiSchedEvent        53  /* vpi_put_value() event */
#define vpiSpecParam         54  /* specparam */
#define vpiSwitch            55  /* transistor switch */
#define vpiSysFuncCall       56  /* system function call */
#define vpiSysTaskCall       57  /* system task call */
#define vpiTableEntry        58  /* UDP state table entry */
#define vpiTask              59  /* task */
#define vpiTaskCall          60  /* task call */
#define vpiTchk              61  /* timing check */
#define vpiTchkTerm          62  /* terminal of timing check */
#define vpiTimeVar           63  /* time variable */
#define vpiTimeQueue         64  /* simulation event queue */
#define vpiUdp               65  /* user-defined primitive */
#define vpiUdpDefn           66  /* UDP definition */
#define vpiUserSystf         67  /* user-defined system task/function */
#define vpiVarSelect         68  /* variable array selection */
#define vpiWait              69  /* wait statement */
#define vpiWhile             70  /* while statement */

/***** object types added with 1364-2001 *****/

#define vpiAttribute         105  /* attribute of an object */
#define vpiBitSelect         106  /* Bit-select of parameter, var select */
#define vpiCallback          107  /* callback object */
#define vpiDelayTerm         108  /* Delay term which is a load or driver */
#define vpiDelayDevice       109  /* Delay object within a net */
#define vpiFrame             110  /* reentrant task/func frame */
#define vpiGateArray         111  /* gate instance array */
#define vpiModuleArray       112  /* module instance array */
#define vpiPrimitiveArray    113  /* vpiprimitiveArray type */
#define vpiNetArray          114  /* multidimensional net */
#define vpiRange             115  /* range declaration */
#define vpiRegArray          116  /* multidimensional reg */
#define vpiSwitchArray       117  /* switch instance array */
#define vpiUdpArray          118  /* UDP instance array */
#define vpiContAssignBit     128  /* Bit of a vector continuous assignment */
#define vpiNamedEventArray   129  /* multidimensional named event */

/***** object types added with 1364-2005 *****/

#define vpiIndexedPartSelect 130  /* Indexed part-select object */
#define vpiGenScopeArray     133  /* array of generated scopes */
#define vpiGenScope          134  /* A generated scope */
#define vpiGenVar            135  /* Object used to instantiate gen scopes */

/***** METHODS *****/
/***** methods used to traverse 1 to 1 relationships *****/

#define vpiCondition         71  /* condition expression */
#define vpiDelay             72  /* net or gate delay */
#define vpiElseStmt          73  /* else statement */
#define vpiForIncStmt        74  /* increment statement in for loop */
#define vpiForInitStmt       75  /* initialization statement in for loop */
#define vpiHighConn          76  /* higher connection to port */
#define vpiLhs               77  /* left-hand side of assignment */
#define vpiIndex             78  /* index of var select, bit-select, etc. */
#define vpiLeftRange         79  /* left range of vector or part-select */
#define vpiLowConn           80  /* lower connection to port */
#define vpiParent            81  /* parent object */
#define vpiRhs               82  /* right-hand side of assignment */
#define vpiRightRange        83  /* right range of vector or part-select */
#define vpiScope             84  /* containing scope object */
#define vpiSysTfCall         85  /* task function call */
```

```

#define vpiTchkDataTerm      86  /* timing check data term */
#define vpiTchkNotifier      87  /* timing check notifier */
#define vpiTchkRefTerm      88  /* timing check reference term */

/***** methods used to traverse 1 to many relationships *****/

#define vpiArgument          89  /* argument to (system) task/function */
#define vpiBit               90  /* bit of vector net or port */
#define vpiDriver            91  /* driver for a net */
#define vpiInternalScope    92  /* internal scope in module */
#define vpiLoad              93  /* load on net or reg */
#define vpiModDataPathIn    94  /* data terminal of a module path */
#define vpiModPathIn        95  /* Input terminal of a module path */
#define vpiModPathOut       96  /* output terminal of a module path */
#define vpiOperand          97  /* operand of expression */
#define vpiPortInst         98  /* connected port instance */
#define vpiProcess          99  /* process in module */
#define vpiVariables       100  /* variables in module */
#define vpiUse              101  /* usage */

/***** methods which can traverse 1 to 1, or 1 to many relationships *****/

#define vpiExpr              102  /* connected expression */
#define vpiPrimitive        103  /* primitive (gate, switch, UDP) */
#define vpiStmt             104  /* statement in process or task */

/***** methods added with 1364-2001 *****/

#define vpiActiveTimeFormat 119  /* active $timeformat() system task */
#define vpiInTerm           120  /* To get to a delay device's drivers. */
#define vpiInstanceArray   121  /* vpiInstance arrays */
#define vpiLocalDriver      122  /* local drivers (within a module) */
#define vpiLocalLoad        123  /* local loads (within a module) */
#define vpiOutTerm         124  /* To get to a delay device's loads. */
#define vpiPorts           125  /* Module port */
#define vpiSimNet          126  /* simulated net after collapsing */
#define vpiTaskFunc        127  /* task/function */

/***** methods added with 1364-2005 *****/

#define vpiBaseExpr        131  /* Indexed part-select's base expression */
#define vpiWidthExpr       132  /* Indexed part-select's width expression */

/***** methods added with 1800-2009 *****/

#define vpiAutomatics      136  /* Automatic variables of a frame */

/***** PROPERTIES *****/
/***** generic object properties *****/

#define vpiUndefined       -1  /* undefined property */
#define vpiType            1  /* type of object */
#define vpiName            2  /* local name of object */
#define vpiFullName        3  /* full hierarchical name */
#define vpiSize            4  /* size of gate, net, port, etc. */
#define vpiFile            5  /* File name in which the object is used */
#define vpiLineNo         6  /* line number where the object is used */

/***** module properties *****/

#define vpiTopModule        7  /* top-level module (Boolean) */
#define vpiCellInstance    8  /* cell (Boolean) */
#define vpiDefName         9  /* module definition name */
#define vpiProtected      10  /* source protected module (Boolean) */

```

```
#define vpiTimeUnit          11  /* module time unit */
#define vpiTimePrecision    12  /* module time precision */
#define vpiDefNetType       13  /* default net type */
#define vpiUnconnDrive     14  /* unconnected port drive strength */
#define vpiHighZ           1    /* No default drive given */
#define vpiPull1          2    /* default pull1 drive */
#define vpiPull0          3    /* default pull0 drive */
#define vpiDefFile        15  /* File name where the module is defined*/
#define vpiDefLineNo      16  /* line number for module definition */
#define vpiDefDelayMode   47  /* Default delay mode for a module */
#define vpiDelayModeNone  1    /* no delay mode specified */
#define vpiDelayModePath  2    /* path delay mode */
#define vpiDelayModeDistrib 3    /* distributed delay mode */
#define vpiDelayModeUnit  4    /* unit delay mode */
#define vpiDelayModeZero  5    /* zero delay mode */
#define vpiDelayModeMTM   6    /* min:typ:max delay mode */
#define vpiDefDecayTime   48  /* Default decay time for a module */

/***** port and net properties *****/

#define vpiScalar          17  /* scalar (Boolean) */
#define vpiVector          18  /* vector (Boolean) */
#define vpiExplicitName    19  /* port is explicitly named */
#define vpiDirection       20  /* direction of port: */
#define vpiInput           1    /* input */
#define vpiOutput          2    /* output */
#define vpiInout           3    /* inout */
#define vpiMixedIO         4    /* mixed input-output */
#define vpiNoDirection     5    /* no direction */
#define vpiConnByName      21  /* connected by name (Boolean) */

#define vpiNetType         22  /* net subtypes: */
#define vpiWire            1    /* wire net */
#define vpiWand            2    /* wire-and net */
#define vpiWor             3    /* wire-or net */
#define vpiTri             4    /* tri net */
#define vpiTri0            5    /* pull-down net */
#define vpiTri1            6    /* pull-up net */
#define vpiTriReg          7    /* three-state reg net */
#define vpiTriAnd          8    /* three-state wire-and net */
#define vpiTriOr           9    /* three-state wire-or net */
#define vpiSupply1         10   /* supply-1 net */
#define vpiSupply0         11   /* supply-0 net */
#define vpiNone            12   /* no default net type (1364-2001) */
#define vpiUwire           13   /* unresolved wire net (1364-2005) */

#define vpiExplicitScalared 23  /* explicitly scalared (Boolean) */
#define vpiExplicitVectored 24  /* explicitly vectored (Boolean) */
#define vpiExpanded        25  /* expanded vector net (Boolean) */
#define vpiImplicitDecl    26  /* implicitly declared net (Boolean) */
#define vpiChargeStrength  27  /* charge decay strength of net */

/* Defined as part of strengths section.
#define vpiLargeCharge      0x10
#define vpiMediumCharge    0x04
#define vpiSmallCharge     0x02
*/

#define vpiArray           28  /* variable array (Boolean) */
#define vpiPortIndex       29  /* Port index */

/***** gate and terminal properties *****/

#define vpiTermIndex       30  /* Index of a primitive terminal */
```

```

#define vpiStrength0      31  /* 0-strength of net or gate */
#define vpiStrength1     32  /* 1-strength of net or gate */
#define vpiPrimType      33  /* primitive subtypes: */
#define vpiAndPrim       1   /* and gate */
#define vpiNandPrim      2   /* nand gate */
#define vpiNorPrim       3   /* nor gate */
#define vpiOrPrim        4   /* or gate */
#define vpiXorPrim       5   /* xor gate */
#define vpiXnorPrim      6   /* xnor gate */
#define vpiBufPrim       7   /* buffer */
#define vpiNotPrim       8   /* not gate */
#define vpiBufif0Prim    9   /* zero-enabled buffer */
#define vpiBufif1Prim   10  /* one-enabled buffer */
#define vpiNotif0Prim   11  /* zero-enabled not gate */
#define vpiNotif1Prim   12  /* one-enabled not gate */
#define vpiNmosPrim     13  /* nmos switch */
#define vpiPmosPrim     14  /* pmos switch */
#define vpiCmosPrim     15  /* cmos switch */
#define vpiRnmosPrim    16  /* resistive nmos switch */
#define vpiRpmosPrim    17  /* resistive pmos switch */
#define vpiRcmosPrim    18  /* resistive cmos switch */
#define vpiRtranPrim    19  /* resistive bidirectional */
#define vpiRtranif0Prim 20  /* zero-enable resistive bidirectional */
#define vpiRtranif1Prim 21  /* one-enable resistive bidirectional */
#define vpiTranPrim     22  /* bidirectional */
#define vpiTranif0Prim  23  /* zero-enabled bidirectional */
#define vpiTranif1Prim  24  /* one-enabled bidirectional */
#define vpiPullupPrim   25  /* pullup */
#define vpiPulldownPrim 26  /* pulldown */
#define vpiSeqPrim      27  /* sequential UDP */
#define vpiCombPrim     28  /* combinational UDP */

/***** path, path terminal, timing check properties *****/

#define vpiPolarity      34  /* polarity of module path... */
#define vpiDataPolarity  35  /* ...or data path: */
#define vpiPositive      1   /* positive */
#define vpiNegative      2   /* negative */
#define vpiUnknown       3   /* unknown (unspecified) */

#define vpiEdge          36  /* edge type of module path: */
#define vpiNoEdge        0x00 /* no edge */
#define vpiEdge01        0x01 /* 0 -> 1 */
#define vpiEdge10        0x02 /* 1 -> 0 */
#define vpiEdge0x        0x04 /* 0 -> x */
#define vpiEdgex1        0x08 /* x -> 1 */
#define vpiEdge1x        0x10 /* 1 -> x */
#define vpiEdgex0        0x20 /* x -> 0 */
#define vpiPosedge       (vpiEdgex1 | vpiEdge01 | vpiEdge0x)
#define vpiNegedge       (vpiEdgex0 | vpiEdge10 | vpiEdge1x)
#define vpiAnyEdge       (vpiPosedge | vpiNegedge)

#define vpiPathType      37  /* path delay connection subtypes: */
#define vpiPathFull      1   /* ( a > b ) */
#define vpiPathParallel  2   /* ( a => b ) */

#define vpiTchkType      38  /* timing check subtypes: */
#define vpiSetup          1   /* $setup */
#define vpiHold           2   /* $hold */
#define vpiPeriod         3   /* $period */
#define vpiWidth          4   /* $width */
#define vpiSkew           5   /* $skew */
#define vpiRecovery       6   /* $recovery */
#define vpiNoChange      7   /* $nochange */

```



```
#define vpiSetupHold      8 /* $setuphold */
#define vpiFullskew     9 /* $fullskew -- added for 1364-2001 */
#define vpiRecrem      10 /* $recrem -- added for 1364-2001 */
#define vpiRemoval     11 /* $removal -- added for 1364-2001 */
#define vpiTimeskew    12 /* $timeskew -- added for 1364-2001 */

/***** expression properties *****/

#define vpiOpType      39 /* operation subtypes: */
#define vpiMinusOp     1 /* unary minus */
#define vpiPlusOp      2 /* unary plus */
#define vpiNotOp       3 /* unary not */
#define vpiBitNegOp    4 /* bitwise negation */
#define vpiUnaryAndOp  5 /* bitwise reduction and */
#define vpiUnaryNandOp 6 /* bitwise reduction nand */
#define vpiUnaryOrOp   7 /* bitwise reduction or */
#define vpiUnaryNorOp  8 /* bitwise reduction nor */
#define vpiUnaryXorOp  9 /* bitwise reduction xor */
#define vpiUnaryXnorOp 10 /* bitwise reduction xnor */
#define vpiSubOp       11 /* binary subtraction */
#define vpiDivOp       12 /* binary division */
#define vpiModOp       13 /* binary modulus */
#define vpiEqOp        14 /* binary equality */
#define vpiNeqOp       15 /* binary inequality */
#define vpiCaseEqOp    16 /* case (x and z) equality */
#define vpiCaseNeqOp   17 /* case inequality */
#define vpiGtOp        18 /* binary greater than */
#define vpiGeOp        19 /* binary greater than or equal */
#define vpiLtOp        20 /* binary less than */
#define vpiLeOp        21 /* binary less than or equal */
#define vpiLShiftOp    22 /* binary left shift */
#define vpiRShiftOp    23 /* binary right shift */
#define vpiAddOp       24 /* binary addition */
#define vpiMultOp      25 /* binary multiplication */
#define vpiLogAndOp    26 /* binary logical and */
#define vpiLogOrOp     27 /* binary logical or */
#define vpiBitAndOp    28 /* binary bitwise and */
#define vpiBitOrOp     29 /* binary bitwise or */
#define vpiBitXorOp    30 /* binary bitwise xor */
#define vpiBitXnorOp   31 /* binary bitwise xnor */
#define vpiBitXnorOp   vpiBitXnorOp /* added with 1364-2001 */
#define vpiConditionOp 32 /* ternary conditional */
#define vpiConcatOp    33 /* n-ary concatenation */
#define vpiMultiConcatOp 34 /* repeated concatenation */
#define vpiEventOrOp   35 /* event or */
#define vpiNullOp      36 /* null operation */
#define vpiListOp      37 /* list of expressions */
#define vpiMinTypMaxOp 38 /* min:typ:max: delay expression */
#define vpiPosedgeOp   39 /* posedge */
#define vpiNegedgeOp   40 /* negedge */
#define vpiArithLShiftOp 41 /* arithmetic left shift (1364-2001) */
#define vpiArithRShiftOp 42 /* arithmetic right shift (1364-2001) */
#define vpiPowerOp     43 /* arithmetic power op (1364-2001) */

#define vpiConstType   40 /* constant subtypes: */
#define vpiDecConst    1 /* decimal integer */
#define vpiRealConst   2 /* real */
#define vpiBinaryConst 3 /* binary integer */
#define vpiOctConst    4 /* octal integer */
#define vpiHexConst    5 /* hexadecimal integer */
#define vpiStringConst 6 /* string literal */
#define vpiIntConst    7 /* integer constant (1364-2001) */
#define vpiTimeConst   8 /* time constant */
```

```

#define vpiBlocking          41  /* blocking assignment (Boolean) */
#define vpiCaseType         42  /* case statement subtypes: */
#define vpiCaseExact        1   /* exact match */
#define vpiCaseX            2   /* ignore X's */
#define vpiCaseZ            3   /* ignore Z's */
#define vpiNetDeclAssign    43  /* assign part of decl (Boolean) */

/***** task/function properties *****/

#define vpiFuncType         44  /* function & system function type */
#define vpiIntFunc          1   /* returns integer */
#define vpiRealFunc         2   /* returns real */
#define vpiTimeFunc         3   /* returns time */
#define vpiSizedFunc        4   /* returns an arbitrary size */
#define vpiSizedSignedFunc  5   /* returns sized signed value */

/** alias 1364-1995 system function subtypes to 1364-2001 function subtypes **/

#define vpiSysFuncType      vpiFuncType
#define vpiSysFuncInt       vpiIntFunc
#define vpiSysFuncReal      vpiRealFunc
#define vpiSysFuncTime      vpiTimeFunc
#define vpiSysFuncSized     vpiSizedFunc

#define vpiUserDefn         45  /*user-defined system task/func(Boolean)*/
#define vpiScheduled        46  /* object still scheduled (Boolean) */

/***** properties added with 1364-2001 *****/

#define vpiActive           49  /* reentrant task/func frame is active */
#define vpiAutomatic        50  /* task/func obj is automatic */
#define vpiCell             51  /* configuration cell */
#define vpiConfig           52  /* configuration config file */
#define vpiConstantSelect  53  /* (Boolean) bit-select or part-select
indices are constant expressions */
#define vpiDecompile        54  /* decompile the object */
#define vpiDefAttribute     55  /* Attribute defined for the obj */
#define vpiDelayType        56  /* delay subtype */
#define vpiModPathDelay     1   /* module path delay */
#define vpiInterModPathDelay 2  /* intermodule path delay */
#define vpiMIPDelay         3   /* module input port delay */
#define vpiIteratorType     57  /* object type of an iterator */
#define vpiLibrary          58  /* configuration library */
#define vpiOffset           60  /* offset from LSB */
#define vpiResolvedNetType  61  /* net subtype after resolution, returns
same subtypes as vpiNetType */
#define vpiSaveRestartID    62  /* unique ID for save/restart data */
#define vpiSaveRestartLocation 63 /* name of save/restart data file */
/* vpiValid, vpiValidTrue, vpiValidFalse are deprecated in 1800-2009 */
#define vpiValid            64  /* reentrant task/func frame or automatic
variable is valid */

#define vpiValidFalse       0
#define vpiValidTrue        1
#define vpiSigned           65  /* TRUE for vpiIODecl and any object in
the expression class if the object
has the signed attribute */

#define vpiLocalParam       70  /* TRUE when a param is declared as a
localparam */
#define vpiModPathHasIfNone 71  /* Mod path has an ifnone statement */

/***** properties added with 1364-2005 *****/

#define vpiIndexedPartSelectType 72 /* Indexed part-select type */
#define vpiPosIndexed            1  /* +: */

```

```
#define vpiNegIndexed          2 /* -: */
#define vpiIsMemory           73 /* TRUE for a one-dimensional reg array */
#define vpiIsProtected        74 /* TRUE for protected design information */

/***** vpi_control() constants (added with 1364-2001) *****/

#define vpiStop                66 /* execute simulator's $stop */
#define vpiFinish              67 /* execute simulator's $finish */
#define vpiReset               68 /* execute simulator's $reset */
#define vpiSetInteractiveScope 69 /* set simulator's interactive scope */

/***** I/O related defines *****/

#define VPI_MCD_STDOUT 0x00000001

/***** STRUCTURE DEFINITIONS *****/

/***** time structure *****/

typedef struct t_vpi_time
{
    PLI_INT32 type; /* [vpiScaledRealTime, vpiSimTime,
                    vpiSuppresTime] */
    PLI_UINT32 high, low; /* for vpiSimTime */
    double real; /* for vpiScaledRealTime */
} s_vpi_time, *p_vpi_time;

/* time types */

#define vpiScaledRealTime 1
#define vpiSimTime 2
#define vpiSuppresTime 3

/***** delay structures *****/

typedef struct t_vpi_delay
{
    struct t_vpi_time *da; /* pointer to application-allocated
                           array of delay values */
    PLI_INT32 no_of_delays; /* number of delays */
    PLI_INT32 time_type; /* [vpiScaledRealTime, vpiSimTime,
                           vpiSuppresTime] */
    PLI_INT32 mtm_flag; /* true for mtm values */
    PLI_INT32 append_flag; /* true for append */
    PLI_INT32 pulserē_flag; /* true for pulserē values */
} s_vpi_delay, *p_vpi_delay;

/***** value structures *****/

/* vector value */

#ifndef VPI_VECVAL /* added in 1364-2005 */
#define VPI_VECVAL

typedef struct t_vpi_vecval
{
    /* following fields are repeated enough times to contain vector */
    PLI_UINT32 aval, bval; /* bit encoding: ab: 00=0, 10=1, 11=X, 01=Z */
} s_vpi_vecval, *p_vpi_vecval;

#endif

/* strength (scalar) value */
```

```
typedef struct t_vpi_strengthval
{
    PLI_INT32 logic;          /* vpi[0,1,X,Z] */
    PLI_INT32 s0, s1;       /* refer to strength coding below */
} s_vpi_strengthval, *p_vpi_strengthval;

/* strength values */

#define vpiSupplyDrive      0x80
#define vpiStrongDrive     0x40
#define vpiPullDrive       0x20
#define vpiWeakDrive       0x08
#define vpiLargeCharge     0x10
#define vpiMediumCharge    0x04
#define vpiSmallCharge     0x02
#define vpiHiZ             0x01

/* generic value */

typedef struct t_vpi_value
{
    PLI_INT32 format; /* vpi[[Bin,Oct,Dec,Hex]Str,Scalar,Int,Real,String,
                    Vector,Strength,Suppress,Time,ObjType]Val */
    union
    {
        PLI_BYTE8          *str;          /* string value */
        PLI_INT32          scalar;       /* vpi[0,1,X,Z] */
        PLI_INT32          integer;     /* integer value */
        double             real;        /* real value */
        struct t_vpi_time  *time;       /* time value */
        struct t_vpi_vecval *vector;    /* vector value */
        struct t_vpi_strengthval *strength; /* strength value */
        PLI_BYTE8          *misc;       /* ...other */
    } value;
} s_vpi_value, *p_vpi_value;

typedef struct t_vpi_arrayvalue
{
    PLI_UINT32 format; /* vpi[Int,Real,Time,ShortInt,LongInt,ShortReal,
                    RawTwoState,RawFourState]Val */
    PLI_UINT32 flags; /* array bit flags- vpiUserAllocFlag */
    union
    {
        PLI_INT32 *integers;          /* integer values */
        PLI_INT16 *shortints;        /* short integer values */
        PLI_INT16 *longints;        /* long integer values */
        PLI_BYTE8 *rawvals;         /* 2/4-state vector elements */
        struct t_vpi_vecval *vectors; /* 4-state vector elements */
        struct t_vpi_time *times;    /* time values */
        double *reals;              /* real values */
        float *shortreals;          /* short real values */
    } value;
} s_vpi_arrayvalue, *p_vpi_arrayvalue;

/* value formats */

#define vpiBinStrVal      1
#define vpiOctStrVal     2
#define vpiDecStrVal     3
#define vpiHexStrVal    4
#define vpiScalarVal     5
#define vpiIntVal       6
#define vpiRealVal      7
```

```
#define vpiStringVal      8
#define vpiVectorVal     9
#define vpiStrengthVal  10
#define vpiTimeVal      11
#define vpiObjTypeVal   12
#define vpiSuppressVal  13
#define vpiShortIntVal  14
#define vpiLongIntVal   15
#define vpiShortRealVal 16
#define vpiRawTwoStateVal 17
#define vpiRawFourStateVal 18

/* delay modes */

#define vpiNoDelay      1
#define vpiInertialDelay 2
#define vpiTransportDelay 3
#define vpiPureTransportDelay 4

/* force and release flags */

#define vpiForceFlag    5
#define vpiReleaseFlag  6

/* scheduled event cancel flag */

#define vpiCancelEvent  7

/* bit mask for the flags argument to vpi_put_value() */

#define vpiReturnEvent  0x1000

/* bit flags for vpi_get_value_array flags field */

#define vpiUserAllocFlag 0x2000

/* bit flags for vpi_put_value_array flags field */

#define vpiOneValue      0x4000
#define vpiPropagateOff  0x8000

/* scalar values */

#define vpi0              0
#define vpi1              1
#define vpiZ              2
#define vpiX              3
#define vpiH              4
#define vpiL              5
#define vpiDontCare      6
/*
#define vpiNoChange      7   Defined under vpiTchkType, but
                             can be used here.
*/

/***** system task/function structure *****/

typedef struct t_vpi_systf_data
{
    PLI_INT32 type;          /* vpiSysTask, vpiSysFunc */
    PLI_INT32 sysfunc_type; /* vpiSysTask, vpi[Int,Real,Time,Sized,
                             SizedSigned]Func */
    PLI_BYTE8 *tfname;     /* first character must be '$' */
    PLI_INT32 (*calltf)(PLI_BYTE8 *);
};
```

```

    PLI_INT32 (*compiletf)(PLI_BYTE8 *);
    PLI_INT32 (*sizetf)(PLI_BYTE8 *);      /* for sized function callbacks only */
    PLI_BYTE8 *user_data;
} s_vpi_systf_data, *p_vpi_systf_data;

#define vpiSysTask          1
#define vpiSysFunc         2

/* the subtypes are defined under the vpiFuncType property */

/***** SystemVerilog execution information structure *****/

typedef struct t_vpi_vlog_info
{
    PLI_INT32 argc;
    PLI_BYTE8 **argv;
    PLI_BYTE8 *product;
    PLI_BYTE8 *version;
} s_vpi_vlog_info, *p_vpi_vlog_info;

/***** PLI error information structure *****/

typedef struct t_vpi_error_info
{
    PLI_INT32 state;          /* vpi[Compile,PLI,Run] */
    PLI_INT32 level;         /* vpi[Notice,Warning,Error,System,Internal] */
    PLI_BYTE8 *message;
    PLI_BYTE8 *product;
    PLI_BYTE8 *code;
    PLI_BYTE8 *file;
    PLI_INT32 line;
} s_vpi_error_info, *p_vpi_error_info;

/* state when error occurred */

#define vpiCompile          1
#define vpiPLI              2
#define vpiRun              3

/* error severity levels */

#define vpiNotice           1
#define vpiWarning          2
#define vpiError            3
#define vpiSystem           4
#define vpiInternal         5

/***** callback structures *****/

/* normal callback structure */

typedef struct t_cb_data
{
    PLI_INT32    reason;          /* callback reason */
    PLI_INT32    (*cb_rtn)(struct t_cb_data *); /* call routine */
    vpiHandle    obj;           /* trigger object */
    p_vpi_time   time;          /* callback time */
    p_vpi_value  value;         /* trigger object value */
    PLI_INT32    index;         /* index of the memory word or
                                var select that changed */

    PLI_BYTE8    *user_data;
} s_cb_data, *p_cb_data;

/***** CALLBACK REASONS *****/

```

```
/* ***** Simulation related ***** */

#define cbValueChange          1
#define cbStmt                 2
#define cbForce                3
#define cbRelease              4

/* ***** Time related ***** */

#define cbAtStartOfSimTime     5
#define cbReadWriteSynch      6
#define cbReadOnlySynch       7
#define cbNextSimTime         8
#define cbAfterDelay          9

/* ***** Action related ***** */

#define cbEndOfCompile        10
#define cbStartOfSimulation   11
#define cbEndOfSimulation     12
#define cbError               13
#define cbTchkViolation       14
#define cbStartOfSave         15
#define cbEndOfSave           16
#define cbStartOfRestart     17
#define cbEndOfRestart       18
#define cbStartOfReset       19
#define cbEndOfReset         20
#define cbEnterInteractive    21
#define cbExitInteractive     22
#define cbInteractiveScopeChange 23
#define cbUnresolvedSystf    24

/* ***** Added with 1364-2001 ***** */

#define cbAssign              25
#define cbDeassign           26
#define cbDisable             27
#define cbPLIError           28
#define cbSignal              29

/* ***** Added with 1364-2005 ***** */

#define cbNBASynch           30
#define cbAtEndOfSimTime     31

/* ***** FUNCTION DECLARATIONS ***** */

/* Include compatibility mode macro definitions. */
#include "vpi_compatibility.h"

/* callback related */

XXTERN vpiHandle vpi_register_cb      PROTO_PARAMS((p_cb_data cb_data_p));
XXTERN PLI_INT32 vpi_remove_cb       PROTO_PARAMS((vpiHandle cb_obj));
XXTERN void      vpi_get_cb_info     PROTO_PARAMS((vpiHandle object,
                                                    p_cb_data cb_data_p));
XXTERN vpiHandle vpi_register_systf  PROTO_PARAMS((p_vpi_systf_data
                                                    systf_data_p));
XXTERN void      vpi_get_systf_info  PROTO_PARAMS((vpiHandle object,
                                                    p_vpi_systf_data
                                                    systf_data_p));

/* for obtaining handles */
```

```
XXTERN vpiHandle vpi_handle_by_name PROTO_PARAMS((PLI_BYTE8 *name,  
vpiHandle scope));  
XXTERN vpiHandle vpi_handle_by_index PROTO_PARAMS((vpiHandle object,  
PLI_INT32 indx));  
  
/* for traversing relationships */  
  
XXTERN vpiHandle vpi_handle PROTO_PARAMS((PLI_INT32 type,  
vpiHandle refHandle));  
XXTERN vpiHandle vpi_handle_multi PROTO_PARAMS((PLI_INT32 type,  
vpiHandle refHandle1,  
vpiHandle refHandle2,  
... ));  
XXTERN vpiHandle vpi_iterate PROTO_PARAMS((PLI_INT32 type,  
vpiHandle refHandle));  
XXTERN vpiHandle vpi_scan PROTO_PARAMS((vpiHandle iterator));  
  
/* for processing properties */  
  
XXTERN PLI_INT32 vpi_get PROTO_PARAMS((PLI_INT32 property,  
vpiHandle object));  
XXTERN PLI_INT64 vpi_get64 PROTO_PARAMS((PLI_INT32 property,  
vpiHandle object));  
XXTERN PLI_BYTE8 *vpi_get_str PROTO_PARAMS((PLI_INT32 property,  
vpiHandle object));  
  
/* delay processing */  
  
XXTERN void vpi_get_delays PROTO_PARAMS((vpiHandle object,  
p_vpi_delay delay_p));  
XXTERN void vpi_put_delays PROTO_PARAMS((vpiHandle object,  
p_vpi_delay delay_p));  
  
/* value processing */  
  
XXTERN void vpi_get_value PROTO_PARAMS((vpiHandle expr,  
p_vpi_value value_p));  
XXTERN vpiHandle vpi_put_value PROTO_PARAMS((vpiHandle object,  
p_vpi_value value_p,  
p_vpi_time time_p,  
PLI_INT32 flags));  
XXTERN void vpi_get_value_array PROTO_PARAMS((vpiHandle object,  
p_vpi_arrayvalue arrayvalue_p,  
PLI_INT32 *index_p,  
PLI_UINT32 num));  
XXTERN void vpi_put_value_array PROTO_PARAMS((vpiHandle object,  
p_vpi_arrayvalue arrayvalue_p,  
PLI_INT32 *index_p,  
PLI_UINT32 num));  
  
/* time processing */  
  
XXTERN void vpi_get_time PROTO_PARAMS((vpiHandle object,  
p_vpi_time time_p));  
  
/* I/O routines */  
  
XXTERN PLI_UINT32 vpi_mcd_open PROTO_PARAMS((PLI_BYTE8 *fileName));  
XXTERN PLI_UINT32 vpi_mcd_close PROTO_PARAMS((PLI_UINT32 mcd));  
XXTERN PLI_BYTE8 *vpi_mcd_name PROTO_PARAMS((PLI_UINT32 cd));  
XXTERN PLI_INT32 vpi_mcd_printf PROTO_PARAMS((PLI_UINT32 mcd,  
PLI_BYTE8 *format,  
... ));  
XXTERN PLI_INT32 vpi_printf PROTO_PARAMS((PLI_BYTE8 *format,
```



```
...));

/* utility routines */

XXTERN PLI_INT32 vpi_compare_objects PROTO_PARAMS((vpiHandle object1,
                                                    vpiHandle object2));
XXTERN PLI_INT32 vpi_chk_error        PROTO_PARAMS((p_vpi_error_info
                                                    error_info_p));
/* vpi_free_object() is deprecated in 1800-2009 */
XXTERN PLI_INT32 vpi_free_object      PROTO_PARAMS((vpiHandle object));
XXTERN PLI_INT32 vpi_release_handle   PROTO_PARAMS((vpiHandle object));
XXTERN PLI_INT32 vpi_get_vlog_info    PROTO_PARAMS((p_vpi_vlog_info
                                                    vlog_info_p));

/* routines added with 1364-2001 */

XXTERN PLI_INT32 vpi_get_data          PROTO_PARAMS((PLI_INT32 id,
                                                    PLI_BYTE8 *dataLoc,
                                                    PLI_INT32 numofBytes));
XXTERN PLI_INT32 vpi_put_data          PROTO_PARAMS((PLI_INT32 id,
                                                    PLI_BYTE8 *dataLoc,
                                                    PLI_INT32 numofBytes));
XXTERN void      *vpi_get_userdata     PROTO_PARAMS((vpiHandle obj));
XXTERN PLI_INT32 vpi_put_userdata     PROTO_PARAMS((vpiHandle obj,
                                                    void *userdata));
XXTERN PLI_INT32 vpi_vprintf           PROTO_PARAMS((PLI_BYTE8 *format,
                                                    va_list ap));
XXTERN PLI_INT32 vpi_mcd_vprintf       PROTO_PARAMS((PLI_UINT32 mcd,
                                                    PLI_BYTE8 *format,
                                                    va_list ap));

XXTERN PLI_INT32 vpi_flush             PROTO_PARAMS((void));
XXTERN PLI_INT32 vpi_mcd_flush         PROTO_PARAMS((PLI_UINT32 mcd));
XXTERN PLI_INT32 vpi_control           PROTO_PARAMS((PLI_INT32 operation,
                                                    ...));
XXTERN vpiHandle vpi_handle_by_multi_index PROTO_PARAMS((vpiHandle obj,
                                                    PLI_INT32 num_index,
                                                    PLI_INT32 *index_array));

/***** GLOBAL VARIABLES *****/

PLI_VEXTERN PLI_DLLESPEC void (*vlog_startup_routines[])();

/* array of function pointers, last pointer should be null */

#undef PLI_EXTERN
#undef PLI_VEXTERN

#ifdef VPI_USER_DEFINED_DLLISPEC
#undef VPI_USER_DEFINED_DLLISPEC
#undef PLI_DLLISPEC
#endif
#ifdef VPI_USER_DEFINED_DLLESPEC
#undef VPI_USER_DEFINED_DLLESPEC
#undef PLI_DLLESPEC
#endif

#ifdef PLI_PROTOTYPES
#undef PLI_PROTOTYPES
#undef PROTO_PARAMS
#undef XXTERN
#undef EETERN
#endif

#ifdef __cplusplus
```

```
}  
#endif  
  
#endif /* VPI_USER_H */
```

Annex L

(normative)

vpi_compatibility.h

L.1 General

This include file contains special macro definitions required to support VPI compatibility mode functionality (see 36.12, especially 36.12.2.1). It is automatically included by vpi_user.h (see Annex K), and therefore should not be included directly from user application code.

L.2 Source code

```

/*****
* vpi_compatibility.h
*
* IEEE 1800-2009 SystemVerilog Verification Procedural Interface (VPI)
*
* NOTE: THIS FILE IS INCLUDED BY vpi_user.h. DO NOT INCLUDE THIS FILE FROM
* USER APPLICATION CODE.
*
* This file contains the macro definitions used by the SystemVerilog PLI
* to implement backwards compatibility mode functionality.
*
*****/
#ifndef VPI_COMPATIBILITY_H
#error "The vpi_compatibility.h file can only be included by vpi_user.h
directly."
#endif
#define VPI_COMPATIBILITY_H
/* Compatibility-mode variants of functions */
#if VPI_COMPATIBILITY_VERSION_1364v1995
|| VPI_COMPATIBILITY_VERSION_1364v2001 || VPI_COMPATIBILITY_VERSION_1364v2005
|| VPI_COMPATIBILITY_VERSION_1800v2005 || VPI_COMPATIBILITY_VERSION_1800v2009
#error "Only one VPI_COMPATIBILITY_VERSION symbol definition is allowed."
#endif
#define vpi_compare_objects vpi_compare_objects_1364v1995
#define vpi_control vpi_control_1364v1995
#define vpi_get vpi_get_1364v1995
#define vpi_get_str vpi_get_str_1364v1995
#define vpi_get_value vpi_get_value_1364v1995
#define vpi_handle vpi_handle_1364v1995
#define vpi_handle_by_index vpi_handle_by_index_1364v1995
#define vpi_handle_by_multi_index vpi_handle_by_multi_index_1364v1995
#define vpi_handle_by_name vpi_handle_by_name_1364v1995
#define vpi_handle_multi vpi_handle_multi_1364v1995
#define vpi_iterate vpi_iterate_1364v1995
#define vpi_put_value vpi_put_value_1364v1995
#define vpi_register_cb vpi_register_cb_1364v1995
#define vpi_scan vpi_scan_1364v1995
#elif VPI_COMPATIBILITY_VERSION_1364v2001
#if VPI_COMPATIBILITY_VERSION_1364v1995 || VPI_COMPATIBILITY_VERSION_1364v2005
|| VPI_COMPATIBILITY_VERSION_1800v2005 || VPI_COMPATIBILITY_VERSION_1800v2009
#error "Only one VPI_COMPATIBILITY_VERSION symbol definition is allowed."
#endif
#define vpi_compare_objects vpi_compare_objects_1364v2001

```

```
#define vpi_control vpi_control_1364v2001
#define vpi_get vpi_get_1364v2001
#define vpi_get_str vpi_get_str_1364v2001
#define vpi_get_value vpi_get_value_1364v2001
#define vpi_handle vpi_handle_1364v2001
#define vpi_handle_by_index vpi_handle_by_index_1364v2001
#define vpi_handle_by_multi_index vpi_handle_by_multi_index_1364v2001
#define vpi_handle_by_name vpi_handle_by_name_1364v2001
#define vpi_handle_multi vpi_handle_multi_1364v2001
#define vpi_iterate vpi_iterate_1364v2001
#define vpi_put_value vpi_put_value_1364v2001
#define vpi_register_cb vpi_register_cb_1364v2001
#define vpi_scan vpi_scan_1364v2001
#elif VPI_COMPATIBILITY_VERSION_1364v2005
#if VPI_COMPATIBILITY_VERSION_1364v1995 || VPI_COMPATIBILITY_VERSION_1364v2001
    || VPI_COMPATIBILITY_VERSION_1800v2005 || VPI_COMPATIBILITY_VERSION_1800v2009
#error "Only one VPI_COMPATIBILITY_VERSION symbol definition is allowed."
#endif
#define vpi_compare_objects vpi_compare_objects_1364v2005
#define vpi_control vpi_control_1364v2005
#define vpi_get vpi_get_1364v2005
#define vpi_get_str vpi_get_str_1364v2005
#define vpi_get_value vpi_get_value_1364v2005
#define vpi_handle vpi_handle_1364v2005
#define vpi_handle_by_index vpi_handle_by_index_1364v2005
#define vpi_handle_by_multi_index vpi_handle_by_multi_index_1364v2005
#define vpi_handle_by_name vpi_handle_by_name_1364v2005
#define vpi_handle_multi vpi_handle_multi_1364v2005
#define vpi_iterate vpi_iterate_1364v2005
#define vpi_put_value vpi_put_value_1364v2005
#define vpi_register_cb vpi_register_cb_1364v2005
#define vpi_scan vpi_scan_1364v2005
#elif VPI_COMPATIBILITY_VERSION_1800v2005
#if VPI_COMPATIBILITY_VERSION_1364v1995 || VPI_COMPATIBILITY_VERSION_1364v2001
    || VPI_COMPATIBILITY_VERSION_1364v2005 || VPI_COMPATIBILITY_VERSION_1800v2009
#error "Only one VPI_COMPATIBILITY_VERSION symbol definition is allowed."
#endif
#define vpi_compare_objects vpi_compare_objects_1800v2005
#define vpi_control vpi_control_1800v2005
#define vpi_get vpi_get_1800v2005
#define vpi_get_str vpi_get_str_1800v2005
#define vpi_get_value vpi_get_value_1800v2005
#define vpi_handle vpi_handle_1800v2005
#define vpi_handle_by_index vpi_handle_by_index_1800v2005
#define vpi_handle_by_multi_index vpi_handle_by_multi_index_1800v2005
#define vpi_handle_by_name vpi_handle_by_name_1800v2005
#define vpi_handle_multi vpi_handle_multi_1800v2005
#define vpi_iterate vpi_iterate_1800v2005
#define vpi_put_value vpi_put_value_1800v2005
#define vpi_register_cb vpi_register_cb_1800v2005
#define vpi_scan vpi_scan_1800v2005
#elif VPI_COMPATIBILITY_VERSION_1800v2009
#if VPI_COMPATIBILITY_VERSION_1364v1995 || VPI_COMPATIBILITY_VERSION_1364v2001
    || VPI_COMPATIBILITY_VERSION_1364v2005 || VPI_COMPATIBILITY_VERSION_1800v2005
#error "Only one VPI_COMPATIBILITY_VERSION symbol definition is allowed."
#endif
#define vpi_compare_objects vpi_compare_objects_1800v2009
#define vpi_control vpi_control_1800v2009
#define vpi_get vpi_get_1800v2009
#define vpi_get_str vpi_get_str_1800v2009
#define vpi_get_value vpi_get_value_1800v2009
#define vpi_handle vpi_handle_1800v2009
#define vpi_handle_by_index vpi_handle_by_index_1800v2009
#define vpi_handle_by_multi_index vpi_handle_by_multi_index_1800v2009
```

```
#define vpi_handle_by_name vpi_handle_by_name_1800v2009  
#define vpi_handle_multi vpi_handle_multi_1800v2009  
#define vpi_iterate vpi_iterate_1800v2009  
#define vpi_put_value vpi_put_value_1800v2009  
#define vpi_register_cb vpi_register_cb_1800v2009  
#define vpi_scan vpi_scan_1800v2009  
#endif
```

Annex M

(normative)

sv_vpi_user.h

M.1 General

This annex shows the contents of the sv_vpi_user.h include file. This is a normative include file that shall be provided by all SystemVerilog simulators.

M.2 Source code

```

/*****
* sv_vpi_user.h
*
* SystemVerilog VPI extensions.
*
* This file contains the constant definitions, structure definitions, and
* routine declarations used by the SystemVerilog Verification Procedural
* Interface (VPI) access routines.
*
*****/

/*****
* NOTE:
* The constant values 600 through 999 are reserved for use in this file.
* - the range 600-749 is reserved for SV VPI model extensions
* - the range 750-779 is reserved for the Coverage VPI
* - the range 800-899 is reserved for future use
* Overlaps in the numerical ranges are permitted for different categories
* of identifiers; e.g.
* - object types
* - properties
* - callbacks
*****/

#ifndef SV_VPI_USER_H
#define SV_VPI_USER_H

#include "vpi_user.h"

#ifdef __cplusplus
extern "C" {
#endif

/***** OBJECT TYPES *****/
#define vpiPackage          600
#define vpiInterface       601
#define vpiProgram         602
#define vpiInterfaceArray  603
#define vpiProgramArray    604
#define vpiTypespec        605

```



```
#define vpiModport 606
#define vpiInterfaceTfDecl 607
#define vpiRefObj 608
#define vpiTypeParameter 609

/* variables */
#define vpiVarBit vpiRegBit
#define vpiLongIntVar 610
#define vpiShortIntVar 611
#define vpiIntVar 612
#define vpiShortRealVar 613
#define vpiByteVar 614
#define vpiClassVar 615
#define vpiStringVar 616
#define vpiEnumVar 617
#define vpiStructVar 618
#define vpiUnionVar 619
#define vpiBitVar 620
#define vpiLogicVar vpiReg
#define vpiArrayVar vpiRegArray
#define vpiClassObj 621
#define vpiChandleVar 622
#define vpiPackedArrayVar 623

/* typespecs */
#define vpiLongIntTypespec 625
#define vpiShortRealTypespec 626
#define vpiByteTypespec 627
#define vpiShortIntTypespec 628
#define vpiIntTypespec 629
#define vpiClassTypespec 630
#define vpiStringTypespec 631
#define vpiChandleTypespec 632
#define vpiEnumTypespec 633
#define vpiEnumConst 634
#define vpiIntegerTypespec 635
#define vpiTimeTypespec 636
#define vpiRealTypespec 637
#define vpiStructTypespec 638
#define vpiUnionTypespec 639
#define vpiBitTypespec 640
#define vpiLogicTypespec 641
#define vpiArrayTypespec 642
#define vpiVoidTypespec 643
#define vpiTypespecMember 644
#define vpiPackedArrayTypespec 692
#define vpiSequenceTypespec 696
#define vpiPropertyTypespec 697
#define vpiEventTypespec 698

#define vpiClockingBlock 650
#define vpiClockingIODecl 651
#define vpiClassDefn 652
#define vpiConstraint 653
#define vpiConstraintOrdering 654

#define vpiDistItem 645
#define vpiAliasStmt 646
#define vpiThread 647
```

```
#define vpiMethodFuncCall      648
#define vpiMethodTaskCall     649

/* concurrent assertions */
#define vpiAssert              686
#define vpiAssume              687
#define vpiCover               688
#define vpiRestrict            901

#define vpiDisableCondition    689
#define vpiClockingEvent      690
/* property decl, spec */
#define vpiPropertyDecl       655
#define vpiPropertySpec       656
#define vpiPropertyExpr       657
#define vpiMulticlockSequenceExpr 658
#define vpiClockedSeq         659
#define vpiClockedProp        902
#define vpiPropertyInst       660
#define vpiSequenceDecl       661
#define vpiCaseProperty        662 /* property case */
#define vpiCasePropertyItem    905 /* property case item */
#define vpiSequenceInst       664
#define vpiImmediateAssert     665
#define vpiImmediateAssume     694
#define vpiImmediateCover     695
#define vpiReturn              666
/* pattern */
#define vpiAnyPattern          667
#define vpiTaggedPattern       668
#define vpiStructPattern       669
/* do .. while */
#define vpiDoWhile             670
/* waits */
#define vpiOrderedWait         671
#define vpiWaitFork            672
/* disables */
#define vpiDisableFork         673
#define vpiExpectStmt          674
#define vpiForeachStmt         675
#define vpiReturnStmt          691
#define vpiFinal               676
#define vpiExtends              677
#define vpiDistribution         678
#define vpiSeqFormalDecl       679
#define vpiPropFormalDecl      699
#define vpiArrayNet            vpiNetArray
#define vpiEnumNet             680
#define vpiIntegerNet          681
#define vpiLogicNet            vpiNet
#define vpiTimeNet             682
#define vpiStructNet           683
#define vpiBreak               684
#define vpiContinue            685
#define vpiPackedArrayNet      693
#define vpiConstraintExpr      747
#define vpiElseConst           748
#define vpiImplication          749
#define vpiConstrIf            738
```

```
#define vpiConstrIfElse          739
#define vpiLetDecl              903
#define vpiLetExpr              904

/***** METHODS *****/
/***** methods used to traverse 1 to 1 relationships *****/
#define vpiActual                700

#define vpiTypedefAlias          701

#define vpiIndexTypespec        702
#define vpiBaseTypespec         703
#define vpiElemTypespec         704

#define vpiInputSkew            706
#define vpiOutputSkew           707
#define vpiGlobalClocking       708
#define vpiDefaultClocking      709
#define vpiDefaultDisableIff    710

#define vpiOrigin                713
#define vpiPrefix                714
#define vpiWith                  715

#define vpiProperty              718

#define vpiValueRange           720
#define vpiPattern               721
#define vpiWeight                722
#define vpiConstraintItem        746

/***** methods used to traverse 1 to many relationships *****/
#define vpiTypedef              725
#define vpiImport                726
#define vpiDerivedClasses        727
#define vpiInterfaceDecl         728

#define vpiMethods               730
#define vpiSolveBefore           731
#define vpiSolveAfter            732

#define vpiWaitingProcesses       734

#define vpiMessages              735
#define vpiLoopVars              737

#define vpiConcurrentAssertions  740
#define vpiMatchItem             741
#define vpiMember                 742
#define vpiElement                743

/***** methods used to traverse 1 to many relationships *****/
#define vpiAssertion              744

/***** methods used to traverse both 1-1 and 1-many relations *****/
#define vpiInstance              745

/*****/
```

```
/* generic object properties */
/* */

#define vpiTop 600

#define vpiUnit 602

#define vpiAccessType 604
#define vpiForkJoinAcc 1
#define vpiExternAcc 2
#define vpiDPIExportAcc 3
#define vpiDPIImportAcc 4

#define vpiArrayType 606
#define vpiStaticArray 1
#define vpiDynamicArray 2
#define vpiAssocArray 3
#define vpiQueueArray 4
#define vpiArrayMember 607

#define vpiIsRandomized 608
#define vpiLocalVarDecls 609
#define vpiOpStrong 656 /* strength of temporal operator */
#define vpiRandType 610
#define vpiNotRand 1
#define vpiRand 2
#define vpiRandC 3
#define vpiPortType 611
#define vpiInterfacePort 1
#define vpiModportPort 2
/* vpiPort is also a port type. It is defined in vpi_user.h */

#define vpiConstantVariable 612
#define vpiStructUnionMember 615

#define vpiVisibility 620
#define vpiPublicVis 1
#define vpiProtectedVis 2
#define vpiLocalVis 3

/* Return values for vpiConstType property */
#define vpiOneStepConst 9
#define vpiUnboundedConst 10
#define vpiNullConst 11

#define vpiAlwaysType 624
#define vpiAlwaysComb 2
#define vpiAlwaysFF 3
#define vpiAlwaysLatch 4

#define vpiDistType 625
#define vpiEqualDist 1 /* constraint equal distribution */
#define vpiDivDist 2 /* constraint divided distribution */

#define vpiPacked 630
#define vpiTagged 632
#define vpiRef 6 /* Return value for vpiDirection property */
#define vpiVirtual 635
```

```
#define vpiIsConstraintEnabled      638

#define vpiClassType                640
#define vpiMailboxClass             1
#define vpiSemaphoreClass           2
#define vpiUserDefinedClass         3

#define vpiMethod                   645
#define vpiIsClockInferred          649
#define vpiIsDeferred               657
#define vpiIsCoverSequence          659
#define vpiQualifier                650
#define vpiNoQualifier              0
#define vpiUniqueQualifier          1
#define vpiPriorityQualifier         2
#define vpiTaggedQualifier          4
#define vpiRandQualifier            8
#define vpiInsideQualifier         16

#define vpiInputEdge                651 /* returns vpiNoEdge, vpiPosedge,
                                       vpiNegedge */
#define vpiOutputEdge               652 /* returns vpiNoEdge, vpiPosedge,
                                       vpiNegedge */

#define vpiGeneric                  653

/* Compatibility-mode property and values (object argument == NULL) */
#define vpiCompatibilityMode        654
#define vpiModel1364v1995          1
#define vpiModel1364v2001          2
#define vpiModel1364v2005          3
#define vpiModel1800v2005          4
#define vpiModel1800v2009          5

#define vpiPackedArrayMember        655
#define vpiStartLine                661
#define vpiColumn                   662
#define vpiEndLine                  663
#define vpiEndColumn                664

/* memory allocation scheme for transient objects */
#define vpiAllocScheme              658
#define vpiAutomaticScheme          1
#define vpiDynamicScheme            2
#define vpiOtherScheme              3

#define vpiObjId                    660

#define vpiDPIPure                   665
#define vpiDPIContext               666
#define vpiDPICStr                   667
#define vpiDPI                      1
#define vpiDPIC                     2
#define vpiDPICIdentifier           668

/***** Operators *****/
#define vpiImplyOp                   50 /* -> implication operator */
#define vpiNonOverlapImplyOp        51 /* |=> nonoverlapped implication */
#define vpiOverlapImplyOp           52 /* |-> overlapped implication operator */
#define vpiAcceptOnOp               83 /* accept_on operator */
```

```

#define vpiRejectOnOp      84 /* reject_on operator */
#define vpiSyncAcceptOnOp 85 /* sync_accept_on operator */
#define vpiSyncRejectOnOp 86 /* sync_reject_on operator */
#define vpiOverlapFollowedByOp 87 /* overlapped followed_by operator */
#define vpiNonOverlapFollowedByOp 88 /* nonoverlapped followed_by operator */
#define vpiNexttimeOp      89 /* nexttime operator */
#define vpiAlwaysOp        90 /* always operator */
#define vpiEventuallyOp    91 /* eventually operator */
#define vpiUntilOp         92 /* until operator */
#define vpiUntilWithOp     93 /* until_with operator */

#define vpiUnaryCycleDelayOp 53 /* binary cycle delay (##) operator */
#define vpiCycleDelayOp     54 /* binary cycle delay (##) operator */
#define vpiIntersectOp      55 /* intersection operator */
#define vpiFirstMatchOp     56 /* first_match operator */
#define vpiThroughoutOp     57 /* throughout operator */
#define vpiWithinOp         58 /* within operator */
#define vpiRepeatOp         59 /* [=] nonconsecutive repetition */
#define vpiConsecutiveRepeatOp 60 /* [*] consecutive repetition */
#define vpiGotoRepeatOp     61 /* [->] goto repetition */

#define vpiPostIncOp        62 /* ++ post-increment */
#define vpiPreIncOp         63 /* ++ pre-increment */
#define vpiPostDecOp        64 /* -- post-decrement */
#define vpiPreDecOp         65 /* -- pre-decrement */

#define vpiMatchOp          66 /* match() operator */
#define vpiCastOp           67 /* type'() operator */
#define vpiIffOp            68 /* iff operator */
#define vpiWildEqOp         69 /* ==? operator */
#define vpiWildNeqOp        70 /* !=? operator */

#define vpiStreamLRop       71 /* left-to-right streaming {>>} operator */
#define vpiStreamRLop       72 /* right-to-left streaming {<<} operator */

#define vpiMatchedOp        73 /* the .matched sequence operation */
#define vpiTriggeredOp      74 /* the .triggered sequence operation */
#define vpiAssignmentPatternOp 75 /* '{}' assignment pattern */
#define vpiMultiAssignmentPatternOp 76 /* '{n{}} multi assignment pattern */
#define vpiIfOp             77 /* if operator */
#define vpiIfElseOp         78 /* if-else operator */
#define vpiCompAndOp        79 /* Composite and operator */
#define vpiCompOrOp         80 /* Composite or operator */
#define vpiImpliesOp        94 /* implies operator */
#define vpiInsideOp         95 /* inside operator */
#define vpiTypeOp           81 /* type operator */
#define vpiAssignmentOp     82 /* Normal assignment */

/***** task/function properties *****/
#define vpiOtherFunc        6 /* returns other types; for property vpiFuncType */
/* vpiValid,vpiValidTrue,vpiValidFalse are deprecated in 1800-2009 */

/***** value for vpiValid *****/
#define vpiValidUnknown    2 /* Validity of variable is unknown */

/***** STRUCTURE DEFINITIONS *****/

/***** structure *****/

```

```

/***** CALLBACK REASONS *****/
#define cbStartOfThread      600 /* callback on thread creation */
#define cbEndOfThread        601 /* callback on thread termination */
#define cbEnterThread        602 /* callback on reentering thread */
#define cbStartOfFrame       603 /* callback on frame creation */
#define cbEndOfFrame         604 /* callback on frame exit */
#define cbSizeChange         605 /* callback on array variable size change */
#define cbCreateObj          700 /* callback on class object creation */
#define cbReclaimObj         701 /* callback on class object reclaimed by
                                automatic memory management */
#define cbEndOfObject        702 /* callback on transient object deletion */

/***** FUNCTION DECLARATIONS *****/

/***** Coverage VPI *****/
/***** Coverage VPI *****/
/***** Coverage VPI *****/

/* coverage control */
#define vpiCoverageStart      750
#define vpiCoverageStop      751
#define vpiCoverageReset     752
#define vpiCoverageCheck     753
#define vpiCoverageMerge     754
#define vpiCoverageSave      755

/* coverage type properties */
#define vpiAssertCoverage     760
#define vpiFsmStateCoverage  761
#define vpiStatementCoverage  762
#define vpiToggleCoverage    763

/* coverage status properties */
#define vpiCovered            765
#define vpiCoverMax          766
#define vpiCoveredCount      767

/* assertion-specific coverage status properties */
#define vpiAssertAttemptCovered  770
#define vpiAssertSuccessCovered  771
#define vpiAssertFailureCovered  772
#define vpiAssertVacuousSuccessCovered  773
#define vpiAssertDisableCovered  774
#define vpiAssertKillCovered    777

/* FSM-specific coverage status properties */
#define vpiFsmStates          775
#define vpiFsmStateExpression  776

/* FSM handle types */
#define vpiFsm                758
#define vpiFsmHandle          759

/***** Assertion VPI *****/
/***** Assertion VPI *****/
/***** Assertion VPI *****/
```

```
/* assertion callback types */
#define cbAssertionStart 606
#define cbAssertionSuccess 607
#define cbAssertionFailure 608
#define cbAssertionVacuousSuccess 657
#define cbAssertionDisabledEvaluation 658
#define cbAssertionStepSuccess 609
#define cbAssertionStepFailure 610
#define cbAssertionDisable 611
#define cbAssertionEnable 612
#define cbAssertionReset 613
#define cbAssertionKill 614
#define cbAssertionEnablePassAction 645
#define cbAssertionEnableFailAction 646
#define cbAssertionDisablePassAction 647
#define cbAssertionDisableFailAction 648
#define cbAssertionEnableNonvacuousAction 649
#define cbAssertionDisableVacuousAction 650

/* assertion "system" callback types */
#define cbAssertionSysInitialized 615
#define cbAssertionSysOn 616
#define cbAssertionSysOff 617
#define cbAssertionSysKill 631
#define cbAssertionSysEnd 618
#define cbAssertionSysReset 619
#define cbAssertionSysEnablePassAction 651
#define cbAssertionSysEnableFailAction 652
#define cbAssertionSysDisablePassAction 653
#define cbAssertionSysDisableFailAction 654
#define cbAssertionSysEnableNonvacuousAction 655
#define cbAssertionSysDisableVacuousAction 656

/* assertion control constants */
#define vpiAssertionDisable 620
#define vpiAssertionEnable 621
#define vpiAssertionReset 622
#define vpiAssertionKill 623
#define vpiAssertionEnableStep 624
#define vpiAssertionDisableStep 625
#define vpiAssertionClockSteps 626
#define vpiAssertionSysOn 627
#define vpiAssertionSysOff 628
#define vpiAssertionSysKill 632
#define vpiAssertionSysEnd 629
#define vpiAssertionSysReset 630
#define vpiAssertionDisablePassAction 633
#define vpiAssertionEnablePassAction 634
#define vpiAssertionDisableFailAction 635
#define vpiAssertionEnableFailAction 636
#define vpiAssertionDisableVacuousAction 637
#define vpiAssertionEnableNonvacuousAction 638
#define vpiAssertionSysEnablePassAction 639
#define vpiAssertionSysEnableFailAction 640
#define vpiAssertionSysDisablePassAction 641
#define vpiAssertionSysDisableFailAction 642
#define vpiAssertionSysEnableNonvacuousAction 643
#define vpiAssertionSysDisableVacuousAction 644
```



```
typedef struct t_vpi_assertion_step_info {
    PLI_INT32 matched_expression_count;
    vpiHandle *matched_exprs;          /* array of expressions */
    PLI_INT32 stateFrom, stateTo;      /* identify transition */
} s_vpi_assertion_step_info, *p_vpi_assertion_step_info;

typedef struct t_vpi_attempt_info {
    union {
        vpiHandle failExpr;
        p_vpi_assertion_step_info step;
    } detail;
    s_vpi_time attemptStartTime;      /* Time attempt triggered */
} s_vpi_attempt_info, *p_vpi_attempt_info;

/* typedef for vpi_register_assertion_cb callback function */
typedef PLI_INT32(vpi_assertion_callback_func)(
    PLI_INT32 reason,                 /* callback reason */
    p_vpi_time cb_time,              /* callback time */
    vpiHandle assertion,             /* handle to assertion */
    p_vpi_attempt_info info,         /* attempt related information */
    PLI_BYTE8 *user_data             /* user data entered upon registration */
);

vpiHandle vpi_register_assertion_cb(
    vpiHandle assertion,             /* handle to assertion */
    PLI_INT32 reason,                /* reason for which callbacks needed */
    vpi_assertion_callback_func *cb_rtn,
    PLI_BYTE8 *user_data            /* user data to be supplied to cb */
);

#ifdef __cplusplus
}
#endif

#endif
```

Annex N

(normative)

Algorithm for probabilistic distribution functions

N.1 General

This annex lists the C source code for the SystemVerilog probabilistic distribution system functions. [Table N.1](#) shows the SystemVerilog system function names with their corresponding C functions. See [20.15](#) for the syntactical definition of these system functions.

Table N.1—SystemVerilog to C function cross-listing

SystemVerilog function	C function
\$dist_uniform	rtl_dist_uniform
\$dist_normal	rtl_dist_normal
\$dist_exponential	rtl_dist_exponential
\$dist_poisson	rtl_dist_poisson
\$dist_chi_square	rtl_dist_chi_square
\$dist_t	rtl_dist_t
\$dist_erlang	rtl_dist_erlang
\$random	rtl_dist_uniform (seed, LONG_MIN, LONG_MAX)

The algorithm for these functions is defined by the C code in [N.2](#).

N.2 Source code

```

/*
 * Algorithm for probabilistic distribution functions.
 *
 * IEEE Std 1800-2009 SystemVerilog Unified Hardware Design and Verification Language
 */

#include <limits.h>

static double uniform( long *seed, long start, long end );
static double normal( long *seed, long mean, long deviation);
static double exponential( long *seed, long mean);
static long poisson( long *seed, long mean);
static double chi_square( long *seed, long deg_of_free);
static double t( long *seed, long deg_of_free);
static double erlangian( long *seed, long k, long mean);

long
rtl_dist_chi_square( seed, df )
    long *seed;

```

```
        long df;
    {
        double r;
        long i;

        if(df>0)
        {
            r=chi_square(seed,df);
            if(r>=0)
            {
                i=(long)(r+0.5);
            }
            else
            {
                r = -r;
                i=(long)(r+0.5);
                i = -i;
            }
        }
        else
        {
            print_error("WARNING: Chi_square distribution must ",
                "have positive degree of freedom\n");
            i=0;
        }

        return (i);
    }

long
rtl_dist_erlang( seed, k, mean )
    long *seed;
    long k, mean;
{
    double r;
    long i;

    if(k>0)
    {
        r=erlangian(seed,k,mean);
        if(r>=0)
        {
            i=(long)(r+0.5);
        }
        else
        {
            r = -r;
            i=(long)(r+0.5);
            i = -i;
        }
    }
    else
    {
        print_error("WARNING: k-stage erlangian distribution ",
            "must have positive k\n");
        i=0;
    }

    return (i);
}
```

```
long
rtl_dist_exponential( seed, mean )
    long *seed;
    long mean;
{
    double r;
    long i;

    if(mean>0)
    {
        r=exponential(seed,mean);
        if(r>=0)

            {
                i=(long) (r+0.5);
            }
            else

            {
                r = -r;
                i=(long) (r+0.5);
                i = -i;
            }
        }
        else
        {
            print_error("WARNING: Exponential distribution must ",
                "have a positive mean\n");
            i=0;
        }

        return (i);
    }

long
rtl_dist_normal( seed, mean, sd )
    long *seed;
    long mean, sd;
{
    double r;
    long i;

    r=normal(seed,mean,sd);
    if(r>=0)
    {
        i=(long) (r+0.5);
    }
    else
    {
        r = -r;
        i=(long) (r+0.5);
        i = -i;
    }

    return (i);
}

long
rtl_dist_poisson( seed, mean )
```

```
        long *seed;
        long mean;
    {
        long i;

        if(mean>0)
        {
            i=poisson(seed,mean);
        }
        else
        {
            print_error("WARNING: Poisson distribution must have a ",
                "positive mean\n");
            i=0;
        }
        return (i);
    }

long
rtl_dist_t( seed, df )
    long *seed;
    long df;
{
    double r;
    long i;

    if(df>0)
    {
        r=t(seed,df);
        if(r>=0)
        {
            i=(long)(r+0.5);
        }
        else
        {
            r = -r;
            i=(long)(r+0.5);
            i = -i;
        }
    }
    else
    {
        print_error("WARNING: t distribution must have positive ",
            "degree of freedom\n");
        i=0;
    }
    return (i);
}

long
rtl_dist_uniform(seed, start, end)
    long *seed;
    long start, end;
{
    double r;
    long i;

    if (start >= end) return(start);

    if (end != LONG_MAX)
    {
```

```
end++;
r = uniform( seed, start, end );
if (r >= 0)

{
    i = (long) r;
}
else
{
    i = (long) (r-1);
}
if (i<start) i = start;
if (i>=end) i = end-1;
}
else if (start!=LONG_MIN)
{
    start--;
r = uniform( seed, start, end) + 1.0;
if (r>=0)
{
    i = (long) r;
}
else
{
    i = (long) (r-1);
}
if (i<=start) i = start+1;
if (i>end) i = end;
}
else
{
    r =(uniform(seed,start,end)+
        2147483648.0)/4294967295.0);
r = r*4294967296.0-2147483648.0;
if (r>=0)
{
    i = (long) r;
}
else
{
    i = (long) (r-1);
}
}

return (i);
}

static double
uniform( seed, start, end )
long *seed, start, end;
{
    union u_s
    {
        float s;
        unsigned stemp;
    } u;

    double d = 0.00000011920928955078125;
    double a,b,c;
```

```
    if ((*seed) == 0)
        *seed = 259341593;

    if (start >= end)
    {
        a = 0.0;
        b = 2147483647.0;
    }
    else
    {
        a = (double) start;
        b = (double) end;
    }
    *seed = 69069 * (*seed) + 1;
    u.stemp = *seed;

    /*
     * This relies on IEEE floating point format
     */

    u.stemp = (u.stemp >> 9) | 0x3f800000;

    c = (double) u.s;

    c = c+(c*d);
    c = ((b - a) * (c - 1.0)) + a;

    return (c);
}
```

```
static double
normal(seed,mean,deviation)
long *seed,mean,deviation;
{
    double v1,v2,s;
    double log(), sqrt();

    s = 1.0;
    while((s >= 1.0) || (s == 0.0))
    {
        v1 = uniform(seed,-1,1);
        v2 = uniform(seed,-1,1);
        s = v1 * v1 + v2 * v2;
    }
    s = v1 * sqrt(-2.0 * log(s) / s);
    v1 = (double) deviation;
    v2 = (double) mean;
    return(s * v1 + v2);
}
```

```
static double
exponential(seed,mean)
long *seed,mean;
{
    double log(),n;
    n = uniform(seed,0,1);
    if(n != 0)
    {
        n = -log(n) * mean;
    }
}
```

```
    }
    return(n);
}

static long
poisson(seed,mean)
long *seed,mean;
{
    long n;
    double p,q;
    double exp();

    n = 0;
    q = -(double)mean;
    p = exp(q);
    q = uniform(seed,0,1);
    while(p < q)
    {
        n++;
        q = uniform(seed,0,1) * q;
    }
    return(n);
}

static double
chi_square(seed,deg_of_free)
long *seed,deg_of_free;
{
    double x;
    long k;
    if(deg_of_free % 2)
    {
        x = normal(seed,0,1);
        x = x * x;
    }
    else
    {
        x = 0.0;
    }
    for(k = 2; k <= deg_of_free; k = k + 2)
    {
        x = x + 2 * exponential(seed,1);
    }
    return(x);
}

static double
t(seed,deg_of_free)
long *seed,deg_of_free;

{
    double sqrt(),x;
    double chi2 = chi_square(seed,deg_of_free);
    double div = chi2 / (double)deg_of_free;
    double root = sqrt(div);
    x = normal(seed,0,1) / root;
    return(x);
}

static double
erlangian(seed,k,mean)
```



```
long *seed, k, mean;
{
    double x, log(), a, b;
    long i;

    x=1.0;
    for(i=1; i<=k; i++)

        {
            x = x * uniform(seed, 0, 1);
        }
    a=(double)mean;
    b=(double)k;
    x= -a*log(x)/b;
    return(x);
}
```

Annex O

(informative)

Encryption/decryption flow

O.1 General

This annex describes a number of scenarios that can be used for IP protection. It also shows how the relevant pragmas are used to achieve the desired effect of securely protecting, distributing, and decrypting the model.

O.2 Overview

The data to be protected from inappropriate access or from unauthorized modification is placed within a `protect begin-end` block. Information in the `protect begin-end` block, once encrypted, is also protected.

O.3 Tool vendor secret key encryption system

In the secret key encryption system, the key is tool vendor proprietary and is embedded within the tool itself. The same key is used for both encryption and decryption. (In the electronic design automation domain, this is the simplest scenario and is roughly equivalent to the historical `protect` technique.) It has the drawback of being completely tool vendor-specific. Using this technique, the IP author can encrypt the IP, and any IP consumer with appropriate licenses and the same tool vendor can utilize the IP.

O.3.1 Encryption input

The following pragmas are expected when using the tool vendor secret key encryption system. The pragmas required in the encryption input for use of the secret key encryption system are as follows:

<code>data_keyname=<key name></code>	Where <key name> is a valid name of a tool's embedded key.
<code>begin-end</code>	Surrounding the region(s) to be encrypted.

Additional optional pragmas that may be included are as follows:

<code>author=<string></code>	To embed author name.
<code>author_info=<string></code>	To embed arbitrary author information.
<code>data_keyowner=<owner identity></code>	This shall be the key owner of the provided name.
<code>data_method=<method-specifier></code>	A method appropriate for the given key name. This may be necessary if something other than the default number of rounds, initialization vector, or key width is used.
<code>encoding=<encoding-specifier></code>	To specify a different encoding.
<code>digest_block</code>	If a message authorization code is desired to validate that the message has not been modified.
<code>decrypt_license</code>	If the IP author desires a decryption license.
<code>runtime_license</code>	If the IP author desires a run-time license.

O.3.2 Encryption output

The encrypting tool should take the input file and copy all cleartext to the corresponding output sections. For each protect begin-end block, it should generate the following:

```
begin_protected           To start the protected region.  
data_keyowner= <owner identity>  
data_keyname=<key name>  
data_method=<method-specifier>  
encoding=<encoding-specifier>  
author=<string>           If provided in the input.  
author_info=<string>      If provided in the input.  
digest_block           Followed on the next line(s) by the encoded encrypted digest.  
data_block             Followed on the next line(s) by the encoded encrypted data com-  
                          posed of the following:  
                          decrypt_license  
                          encrypt_license  
                          <text found between begin-end>  
  
end_protected
```

O.4 IP author secret key encryption system

In this mechanism, the IP is encrypted with the public key (of a public/private key pair) of the IP author, and the decrypting tool will have the IP author's private key in its secure key database. The IP authors will have to provide their private keys to the tools' database so that the tool will be able to decrypt the design.

O.4.1 Encryption input

The following pragmas are expected when using the IP author secret key encryption system:

```
data_keyname=< provider's key name>  
begin-end           Surrounding the region(s) to be encrypted.
```

Additional optional pragmas that may be included are as follows:

```
author=<string>           To embed author name.  
author_info=<string>      To embed arbitrary author information.  
data_keyowner=<owner identity> This shall be the key owner of the provided name.  
data_method= some_publ_priv_encryption_scheme_name <method-specifier>  
                          A method appropriate for the given key name. This may be neces-  
                          sary if something other than the default number of rounds, initializa-  
                          tion vector, or key width is used.  
encoding=<encoding-specifier> To specify a different encoding.  
digest_block           If a message authorization code is desired to validate that the mes-  
                          sage has not been modified.  
decrypt_license         If the IP author desires a decryption license.  
runtime_license        If the IP author desires a run-time license.
```

O.4.2 Encryption output

The encrypting tool should take the input file and copy all cleartext to the corresponding output sections. For each protect **begin-end** block, it should generate the following:

begin_protected	To start the protected region.
data_keyowner =<owner identity>	
data_keyname =<provider's key name>	
data_method =some_publ_priv_encryption_scheme_name	
encoding =<encoding-specifier>	
author =<string>	If provided in the input.
author_info =<string>	If provided in the input.
digest_block	Followed on the next line(s) by the encoded encrypted digest.
data_block	Followed on the next line(s) by the encoded encrypted data composed of the following: decrypt_license encrypt_license <text found between begin-end >
end_protected	

O.5 Digital envelopes

In this mechanism, each recipient has a public and private key for an asymmetric encryption algorithm. The sender encrypts the design using a symmetric key encryption algorithm and then encrypts the symmetric key using the recipient's public key. The encrypted symmetric key is recorded in a **key_block** in the protected envelope. The recipient is able to recover the symmetric key using the appropriate private key and then decrypts the design with the symmetric key. This technique permits efficient encryption methods for the design data, yet secret information is never transmitted without encryption. Digital envelopes can be created using either tool secret key or IP author secret key protection schemes. The keys for the recipient user or tool protect the transmission of the symmetric key that encrypts the design data. By using more than one **key_block**, a single protected envelope can be decrypted by tools from different vendors and/or different users.

In the following example, the **data_method** and **data_keyowner/data_keyname** are used to encrypt the **data_block**. The key to encrypt the **data_block** can be specified either by a **data_keyowner/data_keyname** pair or by a **data_decrypt_key** pragma expression. In the first case, the encrypting tool encrypts the **data_keyowner** and **data_keyname** pragmas with the **key_keymethod/key_keyname** and puts them in the **key_block** along with **data_method**. Alternatively, with the **data_decrypt_key** pragma, the actual key is provided, which is then encrypted with **key_method/key_keyname** and stored in the **key_block**.

In the first approach, the **data_keyowner/data_keyname** should also be present with the decrypting tool. No such dependency exists with the second approach as the key is present in the file itself.

For better security in the first approach, the encrypting tool can actually read the **data_keyowner/data_keyname** key and put it in the **key_block** as **data_decrypt_key**. This step not only will remove the dependency mentioned above, but will also protect against the hit-and-trial breaking of the **data_block** with the existing keys at the IP user's end.

O.5.1 Encryption input

The following pragmas are expected when using the digital envelopes:

key_keyowner=<owner identity>
key_method=some_encryption_scheme_name
key_keyname=<provider's key name>
data_keyname=<provider's key name>
begin-end Surrounding the region(s) to be encrypted.

Additional optional pragmas that may be included are as follows:

author=<string> To embed author name.
author_info=<string> To embed arbitrary author information.
data_keyowner=<owner identity> This shall be the key owner of the provided name.
data_method=<method-specifier> A method appropriate for the given key name. This may be necessary if something other than the default number of rounds, initialization vector, or key width is used
encoding=<encoding-specifier> To specify a different encoding.
digest_block If a message authorization code is desired to validate that the message has not been modified.
decrypt_license If the IP author desires a decryption license.
runtime_license If the IP author desires a run-time license.

O.5.2 Encryption output

The encrypting tool should take the input file and copy all cleartext to the corresponding output sections. For each protect **begin-end** block, it should generate the following:

begin_protected To start the protected region.
key_keyowner=<owner identity>
key_method=some_encryption_scheme_name
key_keyname=<provider's key name>
key_block=<encrypted encoded data> This contains the data_key_owner, data_method, and the symmetric data_key itself in encrypted form.
encoding=<encoding-specifier>
author=<string> If provided in the input.
author_info=<string> If provided in the input.
digest_block Followed on the next line(s) by the encoded encrypted digest.
data_block Followed on the next line(s) by the encoded encrypted data composed of the following:
decrypt_license
encrypt_license
<text found between **begin-end**>
end_protected

Annex P

(informative)

Glossary

For the purposes of this standard, the following terms and definitions apply. The *IEEE Standards Dictionary: Glossary of Terms & Definitions* should be referenced for terms not defined in this annex.¹³

aggregate: A set or collection of singular values, e.g., an aggregate expression, data object, or data type. An aggregate data type is any unpacked structure, unpacked union, or unpacked array data type. Aggregates may be copied or compared as a whole, but not typically used in an expression as a whole.

assertion: An assertion statement.

assertion statement: A statement that specifies the verification function to be performed on an underlying property. An assertion statement is of one of the following kinds:

- **assert**, to specify the property as an obligation for the design that is to be checked to verify that the property holds.
- **assume**, to specify the property as an assumption for the environment. Simulators check that the property holds, while formal tools use the information to generate input stimulus.
- **cover**, to monitor the property evaluation for coverage.
- **restrict**, to specify the property as a constraint on formal verification computations. Simulators do not check the property.

The underlying property describes the behavioral criterion that is evaluated by the assertion statement. The property may be an immediate condition, e.g., that the `read_enable` and `write_enable` signals are mutually exclusive, or it may be a temporal condition, e.g., that if a `read_request` occurs, then a `read_grant` occurs within two clock cycles. An assertion statement is either immediate, for which the underlying property must be an immediate condition, or concurrent, for which the underlying property may be either an immediate or a temporal condition. There is no immediate **restrict** assertion statement. Assertion statements can generate automatic messages to report that the disposition of the evaluation of the underlying property is of interest for the kind of the assertion statement, e.g. a failing evaluation disposition for an **assert** or **assume**, or a passing disposition for a **cover**.

NOTE—SystemVerilog provides special assertion constructs, which are discussed in [Clause 16](#). See [16.2](#) for a discussion of assertion statements.

bit-stream data type: Any data type whose values can be represented as a serial stream of bits. To qualify as a bit-stream data type, each and every bit of the values shall be individually addressable. In other words, a bit-stream data type can be any data type except for a **handle**, **chandle**, **real**, **shortreal**, or **event**.

canonical representation: A data representation format established by convention into which and from which translations can be made with specialized representations.

constant: Either of two types of constants in SystemVerilog: elaboration constant or run-time constant. Parameters and local parameters are elaboration constants. Their values are calculated before elaboration is complete. Elaboration constants can be used to set the range of array types. Run-time constants are variables that can only be set in an initialization expression using the **const** qualifier.

¹³The *IEEE Standards Dictionary: Glossary of Terms & Definitions* is available at <http://shop.ieee.org/>.

context imported task: A direct programming interface (DPI) imported task declared with the 'context' property that is capable of calling exported subroutines and capable of accessing SystemVerilog objects via the SystemVerilog Verification Procedural Interface (VPI) or Programming Language Interface (PLI) calls.

data object: A named entity that has a data value associated with it. Examples of data objects are nets, variables, and parameters. A data object has a data type that determines which values the data object can have.

data type: A set of values and a set of operations that can be performed on those values. Examples of data types are **logic**, **real**, and **string**. Data types can be used to declare data objects or to define user-defined data types that are constructed from other data types.

direct programming interface (DPI): An interface between SystemVerilog and foreign programming languages permitting direct function calls from SystemVerilog to foreign code and from foreign code to SystemVerilog. It has been designed to have low inherent overhead and permit direct exchange of data between SystemVerilog and foreign code.

disable protocol: A set of conventions for setting, checking, and handling disable status.

dynamic: Having values that can be resized or reallocated at run time. Dynamic arrays, associative arrays, queues, class handles, and data types that include such data types are dynamic data types.

elaboration: The process of binding together the components that make up a design. These components can include module instances, primitive instances, interfaces, and the top level of the design hierarchy.

enumerated type: Data types that can declare a data object that can have one of a set of named values. The numerical equivalents of these values can be specified. Values of an enumerated data type can be easily referenced or displayed using the enumerated names, as opposed to the enumerated values.

exported task: A SystemVerilog task that is declared in an export declaration and can be enabled from an imported task.

imported task: A direct programming interface (DPI) foreign code subprogram that can call exported tasks and can directly or indirectly consume simulation time.

integral: **(A)** A data type representing integer values. **(B)** A integer value that may be signed or unsigned, sliced into smaller integral values, or concatenated into larger values. *Syn:* vectored value. **(C)** An expression of an integral data type. **(D)** An object of an integral data type.

interface: An encapsulation of the communication between blocks of a design, allowing a smooth migration from abstract system-level design through successive refinement down to lower level register transfer and structural views of the design. By encapsulating the communication between blocks, the interface construct also facilitates design reuse. The inclusion of interface capabilities is one of the major advantages of SystemVerilog.

Language Reference Manual (LRM): A document describing the syntax, semantics, and usage of a programming language. "SystemVerilog LRM" refers to this standard.

open array: A direct programming interface (DPI) array formal argument for which the packed or unpacked dimension size (or both) is not specified and for which interface routines describe the size of corresponding actual arguments at run time.

packed array: An array where the dimensions are declared before an object name. Packed arrays can have any number of dimensions. A one-dimensional packed array is the same as a vector width declaration in IEEE Std 1364-2005 Verilog. Packed arrays provide a mechanism for subdividing a vector into subfields,

which can be conveniently accessed as array elements. A packed array differs from an unpacked array, in that the whole array is treated as a single vector for arithmetic operations.

process: A thread of one or more programming statements that can be executed independently of other programming statements. Each elaborated instance of an `initial` procedure, `always`, `always_comb`, `always_latch`, `always_ff` procedure, or continuous assignment statement in SystemVerilog is a separate process. These are static processes; their existence is determined by the static instance hierarchy, their execution begins at the start of simulation, and they cannot be created at run time. SystemVerilog also has dynamic processes that can be created, stopped, restarted and destroyed at run time.

signal: An informal term, usually meaning either a variable or net. The context where it is used may imply further restrictions on allowed types.

singular: An expression, data object, or data type that represents a single value, symbol, or handle. A singular data type is any data type except an unpacked structure, unpacked union, or unpacked array data type.

subroutine: An encapsulation of executable code that can be invoked from one or more places. There are two forms of subroutines, tasks and functions.

SystemVerilog: The IEEE 1800 set of abstract modeling and verification extensions to IEEE Std 1364. The many features of SystemVerilog are presented in this standard.

unpacked array: An array where the dimensions are declared after an object name. Unpacked arrays are the same as arrays in IEEE Std 1364-2005 Verilog and can have any number of dimensions. An unpacked array differs from a packed array in that the whole array cannot be used for arithmetic operations. Each element shall be treated separately.

Verification Procedural Interface (VPI): The third generation programming language interface (PLI) access libraries, providing object-oriented access to SystemVerilog behavioral, structural, assertion, and coverage objects.

Verilog: The hardware description language (HDL) in IEEE Std 1364-2005.

Annex Q

(informative)

Mapping of IEEE Std 1364-2005 and IEEE Std 1800-2005 clauses into IEEE Std 1800-2009

[Table Q.1](#) summarizes how clauses and first-level subclauses of the IEEE Std 1364-2005 and IEEE Std 1800-2005 standards were merged together to form this standard. This is a generalized summary, provided as an aid to those who are familiar with the clause numbering of the 2005 standards, and who need to find the same information in this merged document.

This annex is provided as an informative convenience in this version of the IEEE 1800 SystemVerilog standard. It may be removed from future versions of the standard.

Table Q.1—Mapping of LRM clauses

IEEE Std 1800-2009 clause	IEEE Std 1364-2005 clauses	IEEE Std 1800-2005 clauses
1. Overview	1	1
2. Normative references	2	2
3. Design and verification building blocks	(none)	16.1, 19.3, 19.13, 20.1
4. Scheduling semantics	11.1, 11.4–11.6	9
5. Lexical conventions	3	3
6. Data types	4	4, 6
7. Aggregate data types	4.9	4.11, 5
8. Classes	(none)	4.12, 7
9. Processes	9.7–9.9, 10.3	10.7, 10.10, 10.11, 11
10. Assignment statements	5.5.3, 5.6, 6, 9.2, 9.3	6.8, 8.13, 10.3, 11.5
11. Operators and expressions	5	8
12. Procedural programming statements	9.4–9.6	10
13. Tasks and functions (subroutines)	10	12
14. Clocking blocks	(none)	15
15. Interprocess synchronization and communication	9.7.3	14
16. Assertions	(none)	17
17. Checkers	(none)	(none)
18. Constrained random value generation	(none)	13
19. Functional coverage	(none)	18
20. Utility system tasks and system functions	17.3–17.9, 17.11	22.1–22.13
21. I/O system tasks and system functions	17.1, 17.2, 17.10, 18	22.13–22.17, 24

Table Q.1—Mapping of LRM clauses (continued)

IEEE Std 1800-2009 clause	IEEE Std 1364-2005 clauses	IEEE Std 1800-2005 clauses
22. Compiler directives	19	23
23. Modules and hierarchy	12.1–12.3, 12.5–12.8	17.15, 19.4–19.14
24. Programs	(none)	16
25. Interfaces	(none)	20
26. Packages	(none)	19.2
27. Generate constructs	12.4	(none)
28. Gate-level and switch-level modeling	7	(none)
29. User defined primitives (UDPs)	8	(none)
30. Specify blocks	14	(none)
31. Timing checks	15	(none)
32. Backannotation using the standard delay format (SDF)	16, 17.2.10	(none)
33. Configuring the contents of a design	13	21
34. Protected envelopes	28	(none)
35. Direct programming interface (DPI)	(none)	12.5, 26
36. Programming language interface (PLI/VPI) overview	20, 26.1, 26.2, 26.4	(none)
37. VPI object model diagrams	26.3, 26.5, 26.6	27
38. VPI routine definitions	27	(none)
39. Assertion API	(none)	28
40. Code coverage control and API	(none)	29
Annex A (normative) Formal syntax	(none)	A
Annex B (normative) Keywords	(none)	B
Annex C (normative) Deprecation	21–25, F	25
Annex D (informative) Optional system tasks and system functions	C	(none)
Annex E (informative) Optional compiler directives	D	(none)
Annex F (normative) Formal semantics of concurrent assertions	(none)	E
Annex G (normative) Std package	(none)	C
Annex H (normative) DPI C layer	(none)	F
Annex I (normative) svdpi.h	(none)	G
Annex J (normative) Inclusion of foreign language code	(none)	H
Annex K (normative) vpi_user.h	G	(none)
Annex L (normative) vpi_compatibility.h	(none)	(none)
Annex M (normative) sv_vpi_user.h	(none)	I

Table Q.1—Mapping of LRM clauses (continued)

IEEE Std 1800-2009 clause	IEEE Std 1364-2005 clauses	IEEE Std 1800-2005 clauses
Annex N (normative) Algorithm for probabilistic distribution functions	17.9.3	(none)
Annex O (informative) Encryption/decryption flow	H	(none)
Annex P (informative) Glossary	(none)	J
Annex Q (informative) Mapping of IEEE Std 1364-2005 and IEEE Std 1800-2005 clauses into IEEE Std 1800-2009	(none)	(none)
Annex R (informative) Bibliography	(none)	K

Annex R

(informative)

Bibliography

[B1] IEEE Std 1497-2001, IEEE Standard for Standard Delay Format (SDF) for the Electronic Design Process.¹⁴

[B2] ISO/IEC 9899:1999, Programming Languages—C.¹⁵

[B3] *SystemVerilog 3.1a Language Reference Manual, Accellera's Extensions to Verilog*. 2004. Accellera, <http://www.accellera.org>.

¹⁴IEEE publications are available from the Institute of Electrical and Electronics Engineers, 445 Hoes Lane, Piscataway, NJ 08854, USA (<http://standards.ieee.org/>).

¹⁵ISO/IEC publications are available from the ISO Central Secretariat, Case Postale 56, 1 chemin de la Voie-Creuse, CH-1211 Genève 20, Switzerland/Suisse (<http://www.iso.ch/>) and from the IEC Central Office, Case Postale 131, 3 rue de Varembe, CH-1211 Genève 20, Switzerland/Suisse (<http://www.iec.ch/>). ISO/IEC publications are also available in the United States from Global Engineering Documents, 15 Inverness Way East, Englewood, Colorado 80112, USA (<http://global.ihs.com/>). Electronic copies are available in the United States from the American National Standards Institute, 25 West 43rd Street, 4th Floor, New York, NY 10036, USA (<http://www.ansi.org/>).

Annex S

(informative)

IEEE List of Participants

The **SystemVerilog Language Working Group** is entity based. At the time this standard was completed, the SystemVerilog Working Group had the following membership:

Karen Pieper, Accellera Representative, Tabula, Inc., *Chair*
Neil Korpusik, Sun Microsystems, Inc., *Vice Chair*
Johny Srouji, Apple Computer, Inc., *Chair emeritus*
Dennis Brophy, Mentor Graphics Corporation, *Secretary*
Neil Korpusik, Sun Microsystems, Inc., *Technical Chair*
Stuart Sutherland, Sutherland HDL, Inc., *Technical Editor*

Charles Dawson, Cadence Design Systems, Inc.
Yossi Levi, Intel Corporation
Mehdi Mohtashemi, Synopsys, Inc.

Work on this standard was divided among primary committees.

The **Champions Committee** was responsible for ensuring consistency in the work done by each committee.

Neil Korpusik, Sun Microsystems, Inc., *Chair*
Dave Rich, Mentor Graphics Corporation, *Co-Chair*

Shalom Bresticker, Intel Corporation
Surrendra Dudani, Synopsys, Inc.
John Havlicek, Freescale, Inc.

Francoise Martinolle, Cadence Design Systems, Inc.
Brad Pierce, Synopsys, Inc.
Stuart Sutherland, Sutherland HDL, Inc.

The **Basic/Design Committee (SV-BC)** was responsible for the specification of the design features of SystemVerilog.

Matt Maidment, Intel Corporation, *Chair*
Brad Pierce, Synopsys, Inc., *Co-Chair*

Tom Alsop, Intel Corporation
Shalom Bresticker, Intel Corporation
Heath Chambers, HMC Design Verification, Inc.
Cliff Cummings, Sunburst Design, Inc.
Alex Gran, Mentor Graphics Corporation
Mark Hartoog, Synopsys, Inc.
Francoise Martinolle, Cadence Design Systems, Inc.

Don Mills, LCDM Engineering
Karen Pieper, Accellera, Tabula, Inc.
Dave Rich, Mentor Graphics Corporation
Steven Sharp, Cadence Design Systems, Inc.
Stuart Sutherland, Sutherland HDL, Inc.
Gordon Vreugdenhil, Mentor Graphics Corporation
Doug Warmke, Mentor Graphics Corporation

The **Enhancement Committee (SV-EC)** was responsible for the specification of the testbench features of SystemVerilog.

Mehdi Mohtashemi, Synopsys, Inc., *Chair*
Neil Korpusik, Sun Microsystems, Inc., *Co-Chair*

Jonathan Bromley, Doulos, Ltd.
Mike Burns, Freescale, Inc.
Heath Chambers, HMC Design Verification, Inc.
Geoffrey Coram, Analog Devices, Inc.
Cliff Cummings, Sunburst Design, Inc.
Mark Hartoog, Synopsys, Inc.
Francoise Martinolle, Cadence Design Systems, Inc.
Don Mills, LCDM Engineering
Mike Mintz, Trusster, Inc.

Dave Rich, Mentor Graphics Corporation
Ray Ryan, Mentor Graphics Corporation
Arturo Salz, Synopsys, Inc.
David Scott, Mentor Graphics Corporation
Steven Sharp, Cadence Design Systems, Inc.
Stuart Sutherland, Sutherland HDL, Inc.
Gordon Vreugdenhil, Mentor Graphics Corporation
Doug Warmke, Mentor Graphics Corporation

The **Assertions Committee (SV-AC)** was responsible for the specification of the assertion features of SystemVerilog.

Dmitry Korchemny, Intel Corporation, *Chair*
Tom Thatcher, Sun Microsystems, Inc., *Co-Chair*

Doron Bustan, Intel Corporation
Ed Cerny, Synopsys, Inc.
Surrendra Dudani, Synopsys, Inc.
Yaniv Fais, Freescale, Inc.
John Havlicek, Freescale, Inc.

Manisha Kulshrestha, Mentor Graphics Corporation
Johan Martensson, Jasper Communications, Inc.
Lisa Piper, Cadence Design Systems, Inc.
Erik Seligman, Intel Corporation
Bassam Tabbara, Synopsys, Inc.

The **C API Committee (SV-CC)** was responsible for on the specification of the DPI, the SystemVerilog Verification Procedural Interface (VPI), and the additional coverage API.

Charles Dawson, Cadence Design Systems, Inc., *Chair*
Ghassan Khoory, Synopsys, Inc., *Co-Chair*

Anil Arora, Mentor Graphics Corporation
Chuck Berking, Cadence Design Systems, Inc.
Steven Dovich, Cadence Design Systems, Inc.
Ralph Duncan, CloudShield Technologies
Amit Kohli, Cadence Design Systems, Inc.
Andrzej Litwiniuk, Synopsys, Inc.

Francoise Martinolle, Cadence Design Systems, Inc.
Abigail Moorhouse, Mentor Graphics Corporation
Michael Rohleder, Freescale, Inc.
John Shields, Mentor Graphics Corporation
Bassam Tabbara, Synopsys, Inc.
Jim Vellenga, Cadence Design Systems, Inc.

The **Special Committee (SV-SC)** was responsible for defining the new checker constructs, while also maintaining consistency among checkers, assertions, and other aspects of SystemVerilog.

Erik Seligman, Intel Corporation, *Chair*
Tom Thatcher, Sun Microsystems, Inc., *Co-Chair*

Mike Burns, Freescale, Inc.
Eduard Cerny, Synopsys, Inc.
Mirek Forczek, Aldec, Inc.
Mark Hartoog, Synopsys, Inc.
John Havlicek, Freescale, Inc.
Dmitry Korchemny, Intel Corporation
Neil Korpusik, Sun Microsystems, Inc.
Manisha Kulshrestha, Mentor Graphics Corporation

Francoise Martinolle, Cadence Design Systems, Inc.
Mehdi Mohtashemi, Synopsys, Inc.
Abigail Moorhouse, Mentor Graphics Corporation
Lisa Piper, Cadence Design Systems, Inc.
Dave Rich, Mentor Graphics Corporation
Steven Sharp, Cadence Design Systems, Inc.
Gordon Vreugdenhil, Mentor Graphics Corporation
Jin Yang, Intel Corporation

The following members of the entity balloting committee voted on this standard. Balloters may have voted for approval, disapproval, or abstention.

ARM Ltd.
Accellera
Cadence Design
Freescale Semiconductor
Intel

JEITA
Mentor Graphics
Sun Microsystems
Synopsys
Xilinx

When the IEEE-SA Standards Board approved this standard on 11 November 2009, it had the following membership:

Robert M. Grow, *Chair*
Thomas Prevost, *Vice Chair*
Steve M. Mills, *Past Chair*
Judith Gorman, *Secretary*

John Barr
Karen Bartleson
Victor Berman
Ted Burse
Richard DeBlasio
Andy Drozd
Mark Epstein

Alexander Gelman
Jim Hughes
Richard H. Hulett
Young Kyun Kim
Joseph L. Koepfinger*
John Kulick

David J. Law
Ted Olsen
Glenn Parsons
Ronald C. Petersen
Narayanan Ramachandran
Jon Walter Rosdahl
Sam Sciacca

*Member Emeritus

Also included are the following nonvoting IEEE-SA Standards Board liaisons:

Howard L. Wolfman, TAB Representative
Michael Janezic, NIST Representative
Satish K. Aggarwal, NRC Representative

Michelle Turner
IEEE Standards Program Manager, Document Development

Chris Vigil
IEEE Manager, Standards Development Services

Noelle Humenick
IEEE Corporate Client Manager

British Standards Institution (BSI)

BSI is the national body responsible for preparing British Standards and other standards-related publications, information and services.

BSI is incorporated by Royal Charter. British Standards and other standardization products are published by BSI Standards Limited.

About us

We bring together business, industry, government, consumers, innovators and others to shape their combined experience and expertise into standards-based solutions.

The knowledge embodied in our standards has been carefully assembled in a dependable format and refined through our open consultation process. Organizations of all sizes and across all sectors choose standards to help them achieve their goals.

Information on standards

We can provide you with the knowledge that your organization needs to succeed. Find out more about British Standards by visiting our website at bsigroup.com/standards or contacting our Customer Services team or Knowledge Centre.

Buying standards

You can buy and download PDF versions of BSI publications, including British and adopted European and international standards, through our website at bsigroup.com/shop, where hard copies can also be purchased.

If you need international and foreign standards from other Standards Development Organizations, hard copies can be ordered from our Customer Services team.

Subscriptions

Our range of subscription services are designed to make using standards easier for you. For further information on our subscription products go to bsigroup.com/subscriptions.

With **British Standards Online (BSOL)** you'll have instant access to over 55,000 British and adopted European and international standards from your desktop. It's available 24/7 and is refreshed daily so you'll always be up to date.

You can keep in touch with standards developments and receive substantial discounts on the purchase price of standards, both in single copy and subscription format, by becoming a **BSI Subscribing Member**.

PLUS is an updating service exclusive to BSI Subscribing Members. You will automatically receive the latest hard copy of your standards when they're revised or replaced.

To find out more about becoming a BSI Subscribing Member and the benefits of membership, please visit bsigroup.com/shop.

With a **Multi-User Network Licence (MUNL)** you are able to host standards publications on your intranet. Licences can cover as few or as many users as you wish. With updates supplied as soon as they're available, you can be sure your documentation is current. For further information, email bsmusales@bsigroup.com.

BSI Group Headquarters

389 Chiswick High Road London W4 4AL UK

Revisions

Our British Standards and other publications are updated by amendment or revision.

We continually improve the quality of our products and services to benefit your business. If you find an inaccuracy or ambiguity within a British Standard or other BSI publication please inform the Knowledge Centre.

Copyright

All the data, software and documentation set out in all British Standards and other BSI publications are the property of and copyrighted by BSI, or some person or entity that owns copyright in the information used (such as the international standardization bodies) and has formally licensed such information to BSI for commercial publication and use. Except as permitted under the Copyright, Designs and Patents Act 1988 no extract may be reproduced, stored in a retrieval system or transmitted in any form or by any means – electronic, photocopying, recording or otherwise – without prior written permission from BSI. Details and advice can be obtained from the Copyright & Licensing Department.

Useful Contacts:

Customer Services

Tel: +44 845 086 9001

Email (orders): orders@bsigroup.com

Email (enquiries): cservices@bsigroup.com

Subscriptions

Tel: +44 845 086 9001

Email: subscriptions@bsigroup.com

Knowledge Centre

Tel: +44 20 8996 7004

Email: knowledgecentre@bsigroup.com

Copyright & Licensing

Tel: +44 20 8996 7070

Email: copyright@bsigroup.com



...making excellence a habit.™