

BS EN 62841-2-14:2015



BSI Standards Publication

Electric motor-operated hand-held tools, transportable tools and lawn and garden machinery — Safety

Part 2-14: Particular requirements for
hand-held planers

bsi.

...making excellence a habit.™

National foreword

This British Standard is the UK implementation of EN 62841-2-14:2015. It is derived from IEC 62841-2-14:2015. It supersedes BS EN 60745-2-14:2009+A2:2010, which will be withdrawn on 31 August 2019.

NOTE: The BS EN 62841 series supersedes the BS EN 60745 series, the BS EN 61029 series and parts of the BS EN 60335 series (for lawn and garden machinery). BS EN 62841-1:2015 supersedes BS EN 60745-1:2009 and BS EN 61029-1:2009. A withdrawal date for BS EN 60745-1:2009 and BS EN 61029-1:2009 will be fixed upon publication of all standards in the BS EN 62841-2 and BS EN 62841-3 series.

The CENELEC common modifications have been implemented at the appropriate places in the text. The start and finish of each common modification is indicated in the text by tags **[C]** **[C]**.

The UK participation in its preparation was entrusted to Technical Committee CPL/116, Safety of motor-operated electric tools.

A list of organizations represented on this committee can be obtained on request to its secretary.

This publication does not purport to include all the necessary provisions of a contract. Users are responsible for its correct application.

© The British Standards Institution 2016.

Published by BSI Standards Limited 2016

ISBN 978 0 580 88015 5

ICS 25.140.20

Compliance with a British Standard cannot confer immunity from legal obligations.

This British Standard was published under the authority of the Standards Policy and Strategy Committee on 31 January 2016.

Amendments/corrigenda issued since publication

Date	Text affected
------	---------------

ICS 25.140.20

English Version

Electric motor-operated hand-held tools, transportable tools and
lawn and garden machinery - Safety - Part 2-14: Particular
requirements for hand-held planers
(IEC 62841-2-14:2015 , modified)

Outils électroportatifs à moteur, outils portables et machines
pour jardins et pelouses - Sécurité - Partie 2-14: Exigences
particulières pour les raboteuses portatives
(IEC 62841-2-14:2015 , modifiée)

Elektrische motorbetriebene handgeführte Werkzeuge,
transportable Werkzeuge und Rasen- und
Gartenmaschinen - Sicherheit - Teil 2-14: Besondere
Anforderungen für handgeführte Hobel
(IEC 62841-2-14:2015 , modifiziert)

This European Standard was approved by CENELEC on 2015-08-31. CENELEC members are bound to comply with the CEN/CENELEC Internal Regulations which stipulate the conditions for giving this European Standard the status of a national standard without any alteration.

Up-to-date lists and bibliographical references concerning such national standards may be obtained on application to the CEN-CENELEC Management Centre or to any CENELEC member.

This European Standard exists in three official versions (English, French, German). A version in any other language made by translation under the responsibility of a CENELEC member into its own language and notified to the CEN-CENELEC Management Centre has the same status as the official versions.

CENELEC members are the national electrotechnical committees of Austria, Belgium, Bulgaria, Croatia, Cyprus, the Czech Republic, Denmark, Estonia, Finland, Former Yugoslav Republic of Macedonia, France, Germany, Greece, Hungary, Iceland, Ireland, Italy, Latvia, Lithuania, Luxembourg, Malta, the Netherlands, Norway, Poland, Portugal, Romania, Slovakia, Slovenia, Spain, Sweden, Switzerland, Turkey and the United Kingdom.



European Committee for Electrotechnical Standardization
Comité Européen de Normalisation Electrotechnique
Europäisches Komitee für Elektrotechnische Normung

CEN-CENELEC Management Centre: Avenue Marnix 17, B-1000 Brussels

European foreword

The text of document 116/222/FDIS, future edition 1 of IEC 62841-2-14, prepared by IEC/TC 116 "Safety of motor-operated electric tools" was submitted to the IEC-CENELEC parallel vote and approved by CENELEC as EN 62841-2-14:2015.

A draft amendment, which covers common modifications to IEC 62841-2-14:2015 (116/222/FDIS), was prepared by CLC/TC 116, "Safety of motor-operated electric tools" and approved by CENELEC.

The following dates are fixed:

- latest date by which the document has to be implemented at national level by publication of an identical national standard or by endorsement (dop) 2016-08-31
- latest date by which the national standards conflicting with the document have to be withdrawn (dow) 2019-08-31

This document will supersede EN 60745-2-14:2009 + A2:2010.

This European Standard is divided into four parts:

Part 1: General requirements which are common to most hand-held electric motor operated tools (for the purpose of this standard referred to simply as tools) which could come within the scope of this standard;

Part 2, 3 or 4: Requirements for particular types of tools which either supplement or modify the requirements given in Part 1 to account for the particular hazards and characteristics of these specific tools.

This Part 2 is to be used in conjunction with EN 62841-1:2015. When this standard states "addition", "modification" or "replacement", the relevant text in Part 1 is to be adapted accordingly.

This Part 2 supplements or modifies the corresponding clauses in EN 62841-1:2015, so as to convert it into the European Standard: Particular requirements for hand-held planers.

Attention is drawn to the possibility that some of the elements of this document may be the subject of patent rights. CENELEC [and/or CEN] shall not be held responsible for identifying any or all such patent rights.

This document has been prepared under a mandate given to CENELEC by the European Commission and the European Free Trade Association and supports essential requirements of EU Directive(s).

For the relationship with EU Directive(s), see informative Annex ZZ, which is an integral part of this document.

Compliance with the clauses of Part 1 together with this Part 2 provides one means of conforming with the essential health and safety requirements of the Directive concerned.

Warning: Other requirements and other EU Directives can be applicable to the products falling within the scope of this standard.

This European Standard follows the overall requirements of EN ISO 12100.

The following print types are used:

- requirements; in roman type
- *test specifications: in italic type;*
- notes: in smaller roman type.

The terms defined in Clause 3 are printed in **bold typeface**.

Subclauses, notes, tables and figures which are additional to those in Part 1 are numbered starting from 101.

Clauses, subclauses, notes, tables, figures and annexes which are additional to those in IEC 62841-2-14:2015 are prefixed “Z”.

Endorsement notice

The text of the International Standard IEC 62841-2-14:2015 was approved by CENELEC as a European Standard with agreed common modifications.

CONTENTS

FOREWORD.....	5
1 Scope.....	7
2 Normative references	7
3 Terms and definitions.....	7
4 General requirements	7
5 General conditions for the tests	7
6 Radiation, toxicity and similar hazards	8
7 Classification.....	8
8 Marking and instructions.....	8
9 Protection against access to live parts	8
10 Starting	8
11 Input and current	9
12 Heating	9
13 Resistance to heat and fire	9
14 Moisture resistance	9
15 Resistance to rusting	9
16 Overload protection of transformers and associated circuits	9
17 Endurance.....	9
18 Abnormal operation	9
19 Mechanical hazards.....	10
20 Mechanical strength	12
21 Construction.....	12
22 Internal wiring.....	13
23 Components	13
24 Supply connection and external flexible cords	13
25 Terminals for external conductors	13
26 Provision for earthing.....	13
27 Screws and connections	13
28 Creepage distances, clearances and distances through insulation.....	13
Annexes	16
☐ Annex I (normative) Measurement of noise and vibration emissions.....	16 ☐
Annex K (normative) Battery tools and battery packs	20
Annex L (normative) Battery tools and battery packs provided with mains connection or non-isolated sources.....	22
☐ Annex ZZ (informative) Coverage of Essential Requirements of Directive 2006/42/EC.....	23 ☐
Bibliography.....	24
Figure 101 – Examples of cutting heads with basic dimensions.....	14
Figure 102 – Test probe	15
Figure I.101 – Test set-up for planers	18
Figure I.102 – Positions of transducers	19
Table 4 – Required performance levels.....	10
Table I.101 – Test conditions	16

INTERNATIONAL ELECTROTECHNICAL COMMISSION

ELECTRIC MOTOR-OPERATED HAND-HELD TOOLS, TRANSPORTABLE TOOLS AND LAWN AND GARDEN MACHINERY – SAFETY –

Part 2-14: Particular requirements for hand-held planers

FOREWORD

- 1) The International Electrotechnical Commission (IEC) is a worldwide organization for standardization comprising all national electrotechnical committees (IEC National Committees). The object of IEC is to promote international co-operation on all questions concerning standardization in the electrical and electronic fields. To this end and in addition to other activities, IEC publishes International Standards, Technical Specifications, Technical Reports, Publicly Available Specifications (PAS) and Guides (hereafter referred to as "IEC Publication(s)"). Their preparation is entrusted to technical committees; any IEC National Committee interested in the subject dealt with may participate in this preparatory work. International, governmental and non-governmental organizations liaising with the IEC also participate in this preparation. IEC collaborates closely with the International Organization for Standardization (ISO) in accordance with conditions determined by agreement between the two organizations.
- 2) The formal decisions or agreements of IEC on technical matters express, as nearly as possible, an international consensus of opinion on the relevant subjects since each technical committee has representation from all interested IEC National Committees.
- 3) IEC Publications have the form of recommendations for international use and are accepted by IEC National Committees in that sense. While all reasonable efforts are made to ensure that the technical content of IEC Publications is accurate, IEC cannot be held responsible for the way in which they are used or for any misinterpretation by any end user.
- 4) In order to promote international uniformity, IEC National Committees undertake to apply IEC Publications transparently to the maximum extent possible in their national and regional publications. Any divergence between any IEC Publication and the corresponding national or regional publication shall be clearly indicated in the latter.
- 5) IEC itself does not provide any attestation of conformity. Independent certification bodies provide conformity assessment services and, in some areas, access to IEC marks of conformity. IEC is not responsible for any services carried out by independent certification bodies.
- 6) All users should ensure that they have the latest edition of this publication.
- 7) No liability shall attach to IEC or its directors, employees, servants or agents including individual experts and members of its technical committees and IEC National Committees for any personal injury, property damage or other damage of any nature whatsoever, whether direct or indirect, or for costs (including legal fees) and expenses arising out of the publication, use of, or reliance upon, this IEC Publication or any other IEC Publications.
- 8) Attention is drawn to the Normative references cited in this publication. Use of the referenced publications is indispensable for the correct application of this publication.
- 9) Attention is drawn to the possibility that some of the elements of this IEC Publication may be the subject of patent rights. IEC shall not be held responsible for identifying any or all such patent rights.

International Standard IEC 62841-2-14 has been prepared by IEC technical committee 116: Safety of motor-operated electric tools.

The text of this standard is based on the following documents:

FDIS	Report on voting
116/222/FDIS	116/236/RVD

Full information on the voting for the approval of this standard can be found in the report on voting indicated in the above table.

This publication has been drafted in accordance with the ISO/IEC Directives, Part 2.

This Part 2-14 is to be used in conjunction with the first edition of IEC 62841-1 (2014).

This Part 2-14 supplements or modifies the corresponding clauses in IEC 62841-1, so as to convert it into the IEC standard: Particular requirements for hand-held planers.

Where a particular subclause of Part 1 is not mentioned in this Part 2-14, that subclause applies as far as relevant. Where this standard states “addition”, “modification” or “replacement”, the relevant text in Part 1 is to be adapted accordingly.

The following print types are used:

- requirements: in roman type;
- *test specifications: in italic type;*
- notes: in small roman type.

The terms defined in Clause 3 are printed in **bold typeface**.

Subclauses, notes and figures which are additional to those in Part 1 are numbered starting from 101.

A list of all parts of the IEC 62841 series, under the general title: *Electric motor-operated hand-held tools, transportable tools and lawn and garden machinery – Safety*, can be found on the IEC website.

The committee has decided that the contents of this publication will remain unchanged until the stability date indicated on the IEC website under "<http://webstore.iec.ch>" in the data related to the specific publication. At this date, the publication will be

- reconfirmed,
- withdrawn,
- replaced by a revised edition, or
- amended.

A bilingual version of this publication may be issued at a later date.

NOTE The attention of National Committees is drawn to the fact that equipment manufacturers and testing organizations may need a transitional period following publication of a new, amended or revised IEC publication in which to make products in accordance with the new requirements and to equip themselves for conducting new or revised tests.

It is the recommendation of the committee that the content of this publication be adopted for implementation nationally not earlier than 36 months from the date of publication.

ELECTRIC MOTOR-OPERATED HAND-HELD TOOLS, TRANSPORTABLE TOOLS AND LAWN AND GARDEN MACHINERY – SAFETY –

Part 2-14: Particular requirements for hand-held planers

1 Scope

This clause of Part 1 is applicable, except as follows:

Addition:

This part of IEC 62841 applies to **planers**.

2 Normative references

This clause of Part 1 is applicable.

3 Terms and definitions

This clause of Part 1 is applicable, except as follows:

Additional definitions:

3.101

planer

tool intended for removing surface material, equipped with a rotating **cutting head** where the axis of rotation of the **cutting head** is parallel to the plane of the base plate, which is the part supporting the **planer** on the workpiece

Note 1 to entry: The base plate consists of a fixed shoe and an adjustable shoe that determines the depth of cut.

3.102

lift-off device

device which keeps the blade(s) from making contact with a flat surface when the base plate of the **planer** is attempted to be placed on the flat surface

3.103

cutting head

assembly of blades, cutter block, blade fixing elements, relevant screws and spindle, the whole being ready for working

4 General requirements

This clause of Part 1 is applicable.

5 General conditions for the tests

This clause of Part 1 is applicable, except as follows:

5.17 *Addition:*

*The mass of the tool includes the **cutting head** including blades and the dust extraction adapter, if any.*

6 Radiation, toxicity and similar hazards

This clause of Part 1 is applicable.

7 Classification

This clause of Part 1 is applicable.

8 Marking and instructions

This clause of Part 1 is applicable, except as follows:

8.1 Addition:

- **rated no-load speed.**

8.3 Addition:

- direction of rotation of the working spindle. This shall be indicated by an arrow, raised or sunk, or by other means no less visible and indelible.

8.14.1 Addition:

For **planers**, the additional safety instructions as specified in 8.14.1.101 shall be given. This part may be printed separately from the “General power tool safety warnings”.

8.14.1.101 Safety instructions for planers

- Wait for the cutter to stop before setting the tool down.** *An exposed rotating cutter may engage the surface leading to possible loss of control and serious injury.*
- Hold the power tool by insulated gripping surfaces, because the cutter may contact its own cord.** *Cutting a "live" wire may make exposed metal parts of the power tool "live" and could give the operator an electric shock.*
- Use clamps or another practical way to secure and support the workpiece to a stable platform.** *Holding the workpiece by your hand or against the body leaves it unstable and may lead to loss of control.*

8.14.2 b) Addition:

- 101) instructions on how to adjust the entire range of the depth of cut;
- 102) instruction on the correct use of the dust collection system.

8.14.2 c) Addition:

- 101) information about types of **cutting heads** which can be used, if applicable;
- 102) instructions for the changing of the blades and their adjustment to the correct position;
- 103) instruction on how to properly clean/clear the chip ejection opening.

9 Protection against access to live parts

This clause of Part 1 is applicable.

10 Starting

This clause of Part 1 is applicable.

11 Input and current

This clause of Part 1 is applicable.

12 Heating

This clause of Part 1 is applicable.

13 Resistance to heat and fire

This clause of Part 1 is applicable.

14 Moisture resistance

This clause of Part 1 is applicable.

15 Resistance to rusting

This clause of Part 1 is applicable.

16 Overload protection of transformers and associated circuits

This clause of Part 1 is applicable.

17 Endurance

This clause of Part 1 is applicable, except as follows:

17.101 If a **lift-off device** is provided to meet the requirements of 18.8 or 21.18.1.1, it shall be sufficiently durable.

Compliance is checked by a new tool sample completing the following test.

*The **planer** is to be set in horizontal position. The **lift-off device** is cycled through its intended range of operation for 50 000 cycles. This sequence is repeated at a rate not less than 10 cycles per minute.*

*After completion of the cycling test as specified above, the **planer** shall then comply with 19.111.*

18 Abnormal operation

This clause of Part 1 is applicable, except as follows:

18.8 *Replacement of Table 4 by the following:*

Table 4 – Required performance levels

Type and purpose of SCF	Minimum Performance Level (PL)
Power switch – prevent unwanted switch-on	c
Power switch – provide desired switch-off for planers with lift-off device	a
Power switch – provide desired switch-off for planers without lift-off device	b
Any electronic control to pass the test of 18.3	a
Overspeed prevention to prevent output speed above 130 % of rated no-load speed	b
Provide desired direction of rotation	a
Prevent exceeding thermal limits as in Clause 18	a
Prevent self-resetting as required in 23.3	b
Lock-off function as required by 21.18.1.2	b

19 Mechanical hazards

This clause of Part 1 is applicable, except as follows:

19.1 Addition:

For the requirements given in 19.107, 19.108 and 19.109, only the test probe shown in Figure 102 is used.

19.4.101 Planers with a mass according to 5.17 exceeding 3 kg shall have at least two handles. The auxiliary handle, if any, may also be used for the depth-of-cut setting, provided the adjustment of depth of cut is achieved by a rotary action.

Compliance is checked by inspection and by measurement.

19.101 The **cutting head** shall be cylindrically shaped except for the blades, the gullet and the blade clamping means.

The maximum gullet width s shall be

$$s_{\max} = 0,235 d + 7,2 \text{ mm}$$

where d is the diameter of the rotating circle of the cutting edges. See Figure 101.

Compliance is checked by inspection and by measurement.

19.102 The blades when aligned with the fixed shoe shall not project by more than 1,1 mm radially beyond the cutter block (as per dimension “a” in Figure 101).

Compliance is checked by measurement.

19.103 At any depth of cut, the distance “b” (see Figure 101) between the rotating circle of the cutting edges and the trailing edge on the adjustable shoe shall not exceed 5 mm measured radially.

Compliance is checked by inspection and by measurement.

19.104 The blades shall be secured in the cutter block in such a way that friction alone is not relied upon to prevent the radial ejection of the blades.

Compliance is checked by inspection.

19.105 Cutting heads shall be designed and made of such materials that they withstand the forces and loads expected in **normal use**.

Compliance is checked by the following test:

*An overspeed test shall be made on a sample **cutting head**, equipped with blades for the largest cutting diameter and the largest cutting edge width, the test speed being 1,5 times the **rated no-load speed**. If applicable, tension elements such as clamping screws shall be tightened in accordance with the instructions required by 8.14.2 b).*

*After the test, the **cutting head** shall not be deformed or cracked, no screws shall be loosened and displacements of separable parts shall be less than specified in the test procedure.*

The test procedure is as follows:

- 1) Measure the **cutting head** dimensions.
- 2) Bring the **cutting head** to the **rated no-load speed**, for 1 min.
- 3) Stop and re-measure the **cutting head**; measured displacements of the separable parts of the **cutting head** shall not be greater than 0,15 mm.
- 4) Bring the **cutting head** to the test speed, for 1 min.
- 5) Stop and re-measure the **cutting head** and compare the results with those obtained from step 3. The compared displacements shall not exceed 0,15 mm.

19.106 Clamping screws or bolts shall not project beyond the cutter block as shown in Figure 101.

Compliance is checked by inspection.

19.107 It shall not be possible to inadvertently touch rotating parts from the sides of the **planer**, except for the cases covered by 19.108.

Compliance is checked by the following test:

*The **planer** is set to minimum depth of cut and is positioned with the shoes resting on a flat surface that extends beyond the **planer** by at least 100 mm in all directions. Any **lift-off device** is disabled. The accessibility is checked by means of the test probe shown in Figure 102 with a force not exceeding 5 N.*

19.108 Planers with rabbeting facilities shall be provided with a **guard** that avoids inadvertent contact at the sides with the blades.

NOTE Rabbeting is also known as rebating.

Compliance is checked by inspection and by the following test:

*The **planer** is set to minimum depth of cut and is positioned with the shoes resting on a flat surface that extends beyond the **planer** by at least 100 mm in all directions. Any **lift-off device** is disabled. The accessibility is checked by means of the test probe shown in Figure 102 without any force.*

19.109 It shall not be possible to touch the blades through the chip ejection opening.

*Compliance is checked by testing all apertures for chip ejection with the test probe of Figure 102. It shall not be possible to touch the blades in the **cutting head** at any angle of the probe.*

19.110 Planers shall stop within 10 s after switching off.

Compliance is checked by inspection and by measurement.

19.111 Lift-off device

19.111.1 If a **lift-off device** is provided to meet the requirements of 18.8 or 21.18.1.1, it shall meet the requirements of 19.111.2 and 19.111.3, which are checked only after completing the endurance test of 17.101.

19.111.2 If a **lift-off device** is provided, it shall be designed so that

- it is automatically activated, when the **planer** is lifted up from a horizontal surface; and
- the blade(s) do not make contact, when the **planer** is set at maximum depth of cut in accordance with 8.14.2 b) 101) and placed on a horizontal surface.

Compliance is checked by inspection.

19.111.3 A **lift-off device** shall provide sufficient stability.

Compliance is checked by the following test:

*The **planer** is set to maximum depth of cut in accordance with 8.14.2 b) 101) and with the **supply cord**, if any, removed. The **planer** is then placed on a flat board of medium density fibreboard (MDF) having a density of 650 kg/m³ to 850 kg/m³ that is inclined at an angle of 10°, such that the rear of the **planer** is nearest to the high side of the board and allowed to rest freely for 10 s to 12 s. During the test, the **planer** is permitted to slide, however, the **lift-off device** shall not collapse such that the **planer** blades come into contact with the board.*

20 Mechanical strength

This clause of Part 1 is applicable.

21 Construction

This clause of Part 1 is applicable, except as follows:

Ⓒ 21.18.1.1 Addition:

For **planers**, the **power switch** shall not have any locking device to lock it in the “on” position. **Ⓒ**

21.18.1.2 Addition:

Planers are regarded as tools having a risk associated with inadvertent starting.

21.35 This subclause of Part 1 is applicable.

22 Internal wiring

This clause of Part 1 is applicable.

23 Components

This clause of Part 1 is applicable.

24 Supply connection and external flexible cords

This clause of Part 1 is applicable.

25 Terminals for external conductors

This clause of Part 1 is applicable.

26 Provision for earthing

This clause of Part 1 is applicable.

27 Screws and connections

This clause of Part 1 is applicable.

28 Creepage distances, clearances and distances through insulation

This clause of Part 1 is applicable.

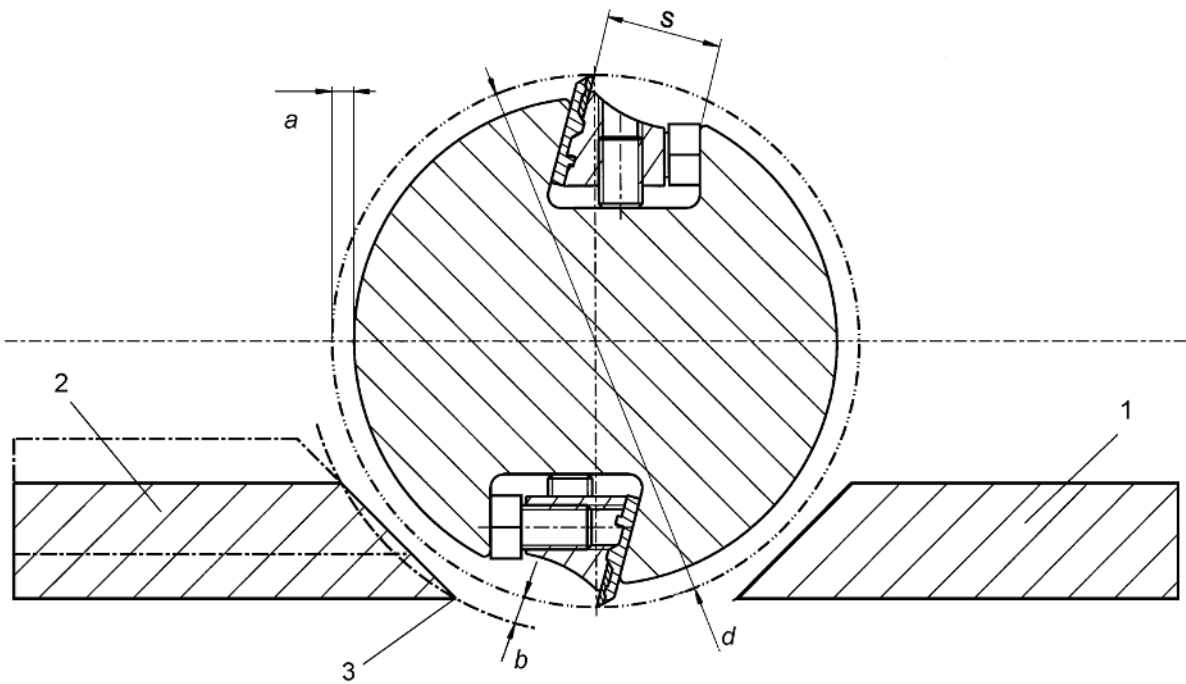

IEC

a) Example 1 and explanation of basic dimensions

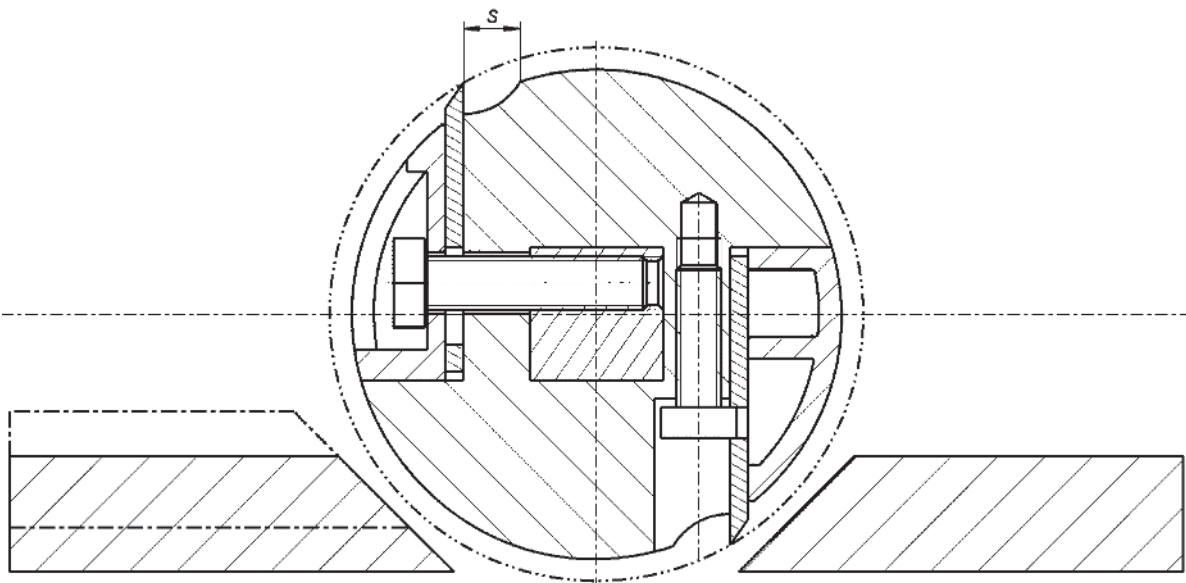

IEC

b) Example 2

Key

- 1 fixed shoe
- 2 adjustable shoe
- 3 trailing edge
- a* radial projection of the blades beyond the cutter block
- b* distance between the rotating circle of the cutting edges and the trailing edge of the adjustable shoe
- d* diameter of the rotating circle of the cutting edges
- s* gullet width

Figure 101 – Examples of cutting heads with basic dimensions

Dimensions in millimetres

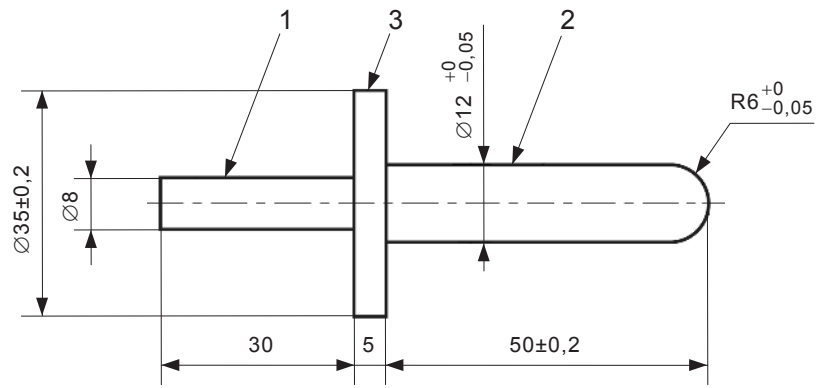

IEC

Key

- 1 handle section
- 2 test section
- 3 probe's flange

Figure 102 – Test probe

Annexes

The annexes of Part 1 are applicable except as follows.

Ⓒ Annex I (normative)

Measurement of noise and vibration emissions Ⓒ

NOTE In Europe (EN 62841-2-14), Annex I is normative.

I.2 Noise test code (grade 2)

This clause of Part 1 is applicable except as follows:

I.2.4 Installation and mounting conditions of the power tools during noise tests

Addition:

Planers are held and used as specified in I.2.5.

I.2.5 Operating conditions

Addition:

Planers are tested under load observing the conditions shown in Table I.101.

The temperature requirements of 5.6 are not applicable.

Table I.101 – Test conditions

Orientation	<p>Planing along a horizontal surface of a softwood workpiece free of knots and having a residual moisture not exceeding 14 %.</p> <p>The workpiece shall have a minimum length of 600 mm, a minimum height of 90 mm and a width <i>B</i>, where <i>B</i> is the maximum planing width of the tool minus (15 ± 2) mm.</p> <p>The workpiece shall be supported on resilient material and fixed vertically by screws, clamps, air cylinders or the like to a test bench of Figure I.1, see Figure I.101. For the fixing, the workpiece may have recesses or the like; an example is shown in Figure I.101. The resilient material shall be mounted so that it does not have any significant resonance in the frequency range that can influence the test result.</p> <p>To prevent absorption of airborne noise, the resilient material shall either</p> <ul style="list-style-type: none"> – not extend the contact area between workpiece and test bench; or – be of non airborne-sound absorbing material, such as rubber. <p>If a parallel guide is provided, this may be used.</p> <p>NOTE Examples of softwood are pine and fir.</p>
Tool bit	Blade as specified for planing softwood. The depth of cut shall be set to maximum capacity.
Feed force	<p>As necessary to achieve a constant feed rate resulting in 10 s to 15 s planing time for one test cycle (600 mm). Equal forces are applied to the main handle and the auxiliary handle, if applicable, avoiding excessive gripping forces.</p> <p>However, if it is not possible to plane the whole surface length within the given time, because the planer may stall, a longer test cycle time is permitted using a feed force as high as possible without stalling the planer.</p>
Test cycle	<p>Planing the complete length of 600 mm at maximum depth of cut.</p> <p>The measurement takes place over a length of approximately 400 mm that does not include the ends of the workpiece.</p>

I.3 Vibration

This clause of Part 1 is applicable except as follows:

I.3.3.2 Location of measurement

Addition:

Figure I.102 shows the positions on the main handle and the auxiliary handle, if applicable.

I.3.5.3 Operating conditions

Addition:

Planers are tested under load according to the conditions shown in Table I.101.

I.3.6.2 Declaration of the vibration total value

Addition:

The vibration total value a_h of the handle with the highest emission and the uncertainty K shall be declared.

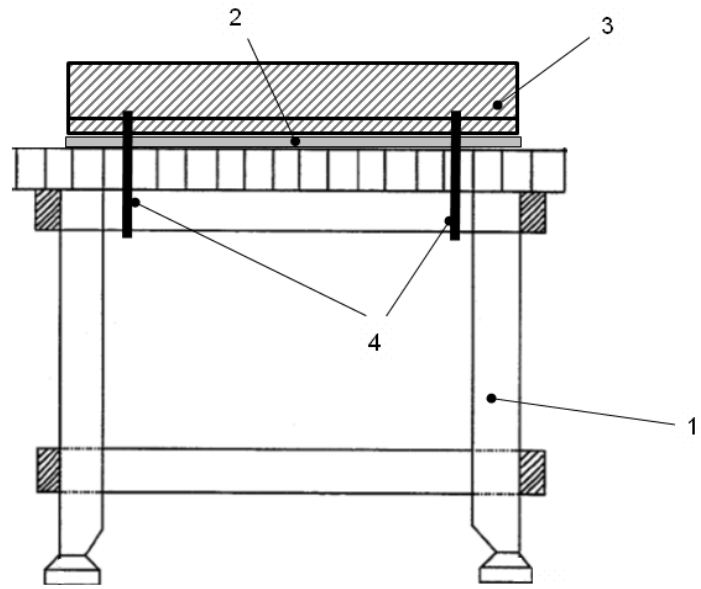

IEC

a) Side view

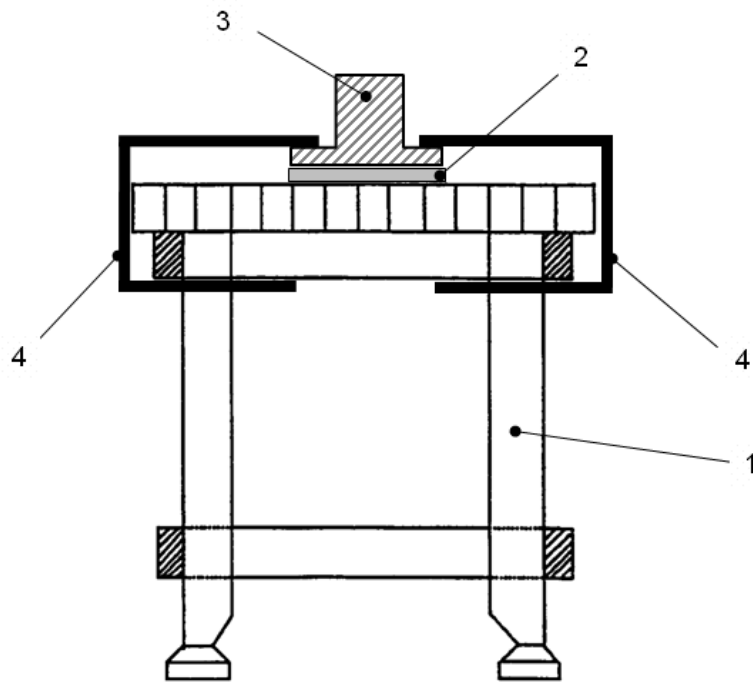

IEC

b) Front view

Key

- 1 test bench of Figure I.1
- 2 resilient material
- 3 workpiece
- 4 fixing means (e.g. clamps)

Figure I.101 – Test set-up for planers

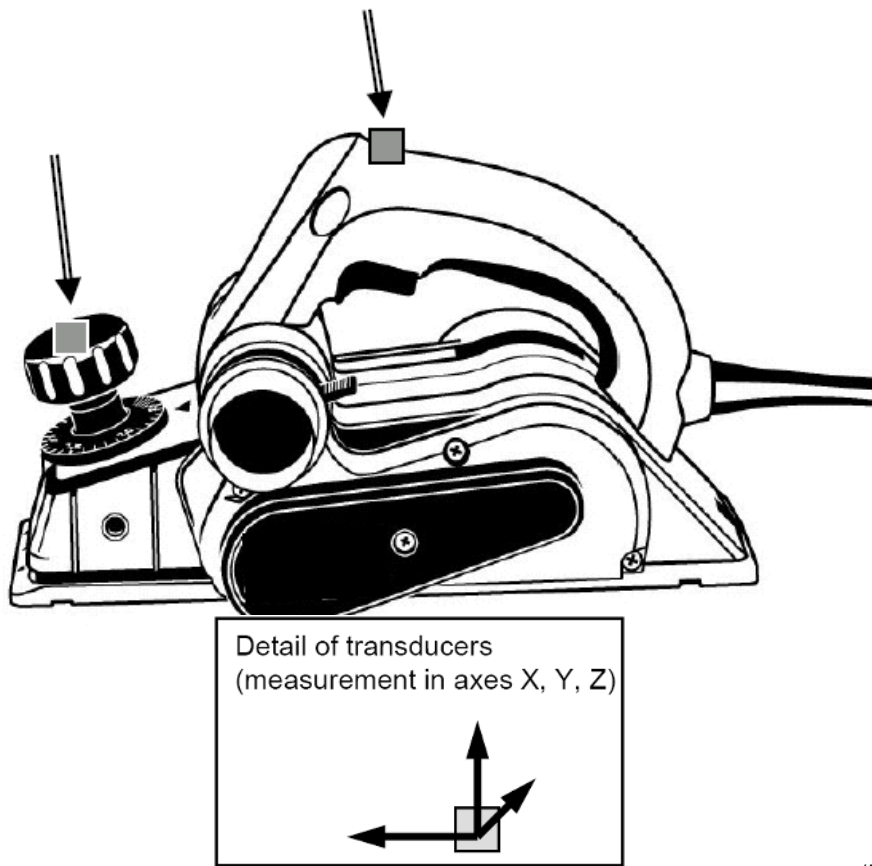

IEC

Figure I.102 – Positions of transducers

Annex K (normative)

Battery tools and battery packs

K.1 Scope

Addition:

All clauses of this Part 2-14 apply unless otherwise specified in this annex.

K.8.14.1.101 Item b) is not applicable.

K.12.2.1 This subclause is not applicable.

K.20.5 This subclause is not applicable.

K.21.18.1.2 *Addition:*

Two separate and dissimilar actions shall be necessary before the motor is switched on (e.g. a **power switch** which has to be pushed in before it can be moved laterally to close the contacts to start the motor). It shall not be possible to achieve these two actions with a single grasping motion or a straight line motion.

Compliance is checked by inspection and by manual test.

☐ **K.21.18.Z101 Isolation device**

Planers with an **integral battery** shall be equipped with an isolation device to prevent the risk of injury from mechanical hazards during **user maintenance** that:

- ensures a reliable disconnection of at least one pole of the battery from the relevant load(s);
- has a reliable mechanical link between the manual control and the disconnecting element(s);
- is equipped with an unambiguous indication of the state of the disconnection device which corresponds to each position of its manual control (actuator);
- protects against accidental reconnection.

NOTE 1 Examples of methods to achieve this disconnection include removable jumpers, removable **batteries** or an electromechanical **power switch** with a direct mechanical link between the actuator and the contact.

NOTE 2 The risk of accidental reconnection for a **power switch** is addressed by the requirement of 21.18.1.2. The other examples in NOTE 1 achieve this by the necessary actions for reconnection.

Compliance is checked by inspection. ☐

K.21.30 This subclause is not applicable.

NOTE In Europe (EN 62841-2-14), the following additional subclause applies:

K.21.18.Z101 Isolation device

Planers with an **integral battery** shall be equipped with an isolation device to prevent the risk of injury from mechanical hazards during **user maintenance** that

- ensures a reliable disconnection of at least one pole of the **battery** from the relevant load(s);
- has a reliable mechanical link between the manual control and the disconnecting element(s);

- is equipped with an unambiguous indication of the state of the disconnection device which corresponds to each position of its manual control (actuator);
- protects against accidental reconnection.

NOTE 1 Examples of methods to achieve this disconnection include removable jumpers, removable **batteries** or a electromechanical **power switch** with a direct mechanical link between the actuator and the contact.

NOTE 2 The risk of accidental reconnection for a **power switch** is addressed by the requirement of 21.18.1.2. The other examples in Note 1 achieve this by the necessary actions for reconnection.

Compliance is checked by inspection.

Annex L (normative)

Battery tools and battery packs provided with mains connection or non-isolated sources

L.1 Scope

Addition:

All clauses of this Part 2-14 apply unless otherwise specified in this annex.

L.21.18.1.2 *Addition:*

Two separate and dissimilar actions shall be necessary before the motor is switched on (e.g. a **power switch** which has to be pushed in before it can be moved laterally to close the contacts to start the motor). It shall not be possible to achieve these two actions with a single grasping motion or a straight line motion.

Compliance is checked by inspection and by manual test.

☐ K.21.18.Z101 Isolation device

Planers with an **integral battery** shall be equipped with an isolation device to prevent the risk of injury from mechanical hazards during **user maintenance** that:

- ensures a reliable disconnection of at least one pole of the battery from the relevant load(s);
- has a reliable mechanical link between the manual control and the disconnecting element(s);
- is equipped with an unambiguous indication of the state of the disconnection device which corresponds to each position of its manual control (actuator);
- protects against accidental reconnection.

NOTE 1 Examples of methods to achieve this disconnection include removable jumpers, removable **batteries** or an electromechanical **power switch** with a direct mechanical link between the actuator and the contact.

NOTE 2 The risk of accidental reconnection for a **power switch** is addressed by the requirement of 21.18.1.2. The other examples in NOTE 1 achieve this by the necessary actions for reconnection.

Compliance is checked by inspection. ☐

Ⓒ Annex ZZ
(informative)

Coverage of Essential Requirements of Directive 2006/42/EC

This European Standard has been prepared under a mandate given to CENELEC by the European Commission and the European Free Trade Association and within its scope the standard covers all relevant Essential Requirements as given in EU Directive 2006/42/EC (Machinery Directive).

Compliance with this standard provides one means of conformity with the specified essential requirements of the Directives concerned.

WARNING: Other requirements and other EU Directives may be applicable to the products falling within the scope of this standard. Ⓒ

Bibliography

The bibliography of Part 1 is applicable.

British Standards Institution (BSI)

BSI is the national body responsible for preparing British Standards and other standards-related publications, information and services.

BSI is incorporated by Royal Charter. British Standards and other standardization products are published by BSI Standards Limited.

About us

We bring together business, industry, government, consumers, innovators and others to shape their combined experience and expertise into standards-based solutions.

The knowledge embodied in our standards has been carefully assembled in a dependable format and refined through our open consultation process. Organizations of all sizes and across all sectors choose standards to help them achieve their goals.

Information on standards

We can provide you with the knowledge that your organization needs to succeed. Find out more about British Standards by visiting our website at bsigroup.com/standards or contacting our Customer Services team or Knowledge Centre.

Buying standards

You can buy and download PDF versions of BSI publications, including British and adopted European and international standards, through our website at bsigroup.com/shop, where hard copies can also be purchased.

If you need international and foreign standards from other Standards Development Organizations, hard copies can be ordered from our Customer Services team.

Subscriptions

Our range of subscription services are designed to make using standards easier for you. For further information on our subscription products go to bsigroup.com/subscriptions.

With **British Standards Online (BSOL)** you'll have instant access to over 55,000 British and adopted European and international standards from your desktop. It's available 24/7 and is refreshed daily so you'll always be up to date.

You can keep in touch with standards developments and receive substantial discounts on the purchase price of standards, both in single copy and subscription format, by becoming a **BSI Subscribing Member**.

PLUS is an updating service exclusive to BSI Subscribing Members. You will automatically receive the latest hard copy of your standards when they're revised or replaced.

To find out more about becoming a BSI Subscribing Member and the benefits of membership, please visit bsigroup.com/shop.

With a **Multi-User Network Licence (MUNL)** you are able to host standards publications on your intranet. Licences can cover as few or as many users as you wish. With updates supplied as soon as they're available, you can be sure your documentation is current. For further information, email bsmusales@bsigroup.com.

Revisions

Our British Standards and other publications are updated by amendment or revision.

We continually improve the quality of our products and services to benefit your business. If you find an inaccuracy or ambiguity within a British Standard or other BSI publication please inform the Knowledge Centre.

Copyright

All the data, software and documentation set out in all British Standards and other BSI publications are the property of and copyrighted by BSI, or some person or entity that owns copyright in the information used (such as the international standardization bodies) and has formally licensed such information to BSI for commercial publication and use. Except as permitted under the Copyright, Designs and Patents Act 1988 no extract may be reproduced, stored in a retrieval system or transmitted in any form or by any means – electronic, photocopying, recording or otherwise – without prior written permission from BSI. Details and advice can be obtained from the Copyright & Licensing Department.

Useful Contacts:

Customer Services

Tel: +44 845 086 9001

Email (orders): orders@bsigroup.com

Email (enquiries): cservices@bsigroup.com

Subscriptions

Tel: +44 845 086 9001

Email: subscriptions@bsigroup.com

Knowledge Centre

Tel: +44 20 8996 7004

Email: knowledgecentre@bsigroup.com

Copyright & Licensing

Tel: +44 20 8996 7070

Email: copyright@bsigroup.com

BSI Group Headquarters

389 Chiswick High Road London W4 4AL UK

