

BS EN 62841-1:2015



BSI Standards Publication

Electric motor-operated hand-held tools, transportable tools and lawn and garden machinery — Safety

Part 1: General requirements

bsi.

...making excellence a habit.™

National foreword

This British Standard is the UK implementation of EN 62841-1:2015. It is derived from IEC 62841-1:2014, incorporating corrigendum May 2014. It supersedes BS EN 60745-1:2009+A11:2010 and BS EN 61029-1:2009+A11:2010. However, BS EN 60745-1:2009+A11:2010 and BS EN 61029-1:2009+A11:2010 remain valid until all parts of the BS EN 62841-2 and BS EN 62841-3 series have been published.

NOTE: The BS EN 62841 series supersedes the BS EN 60745 series, the BS EN 61029 series and parts of the BS EN 60335 series (for lawn and garden machinery).

The CENELEC common modifications have been implemented at the appropriate places in the text. The start and finish of each common modification is indicated in the text by tags **[C]** **[C]**.

IEC corrigendum May 2014 corrects the first row of the Table 12.

The UK participation in its preparation was entrusted to Technical Committee CPL/116, Safety of motor-operated electric tools.

A list of organizations represented on this committee can be obtained on request to its secretary.

This publication does not purport to include all the necessary provisions of a contract. Users are responsible for its correct application.

© The British Standards Institution 2015.

Published by BSI Standards Limited 2015

ISBN 978 0 580 80939 2

ICS 25.140.20

Compliance with a British Standard cannot confer immunity from legal obligations.

This British Standard was published under the authority of the Standards Policy and Strategy Committee on 31 October 2015.

Amendments/corrigenda issued since publication

Date	Text affected
------	---------------

EUROPEAN STANDARD

EN 62841-1

NORME EUROPÉENNE

EUROPÄISCHE NORM

August 2015

ICS 25.140.20

English Version

**Electric motor-operated hand-held tools, transportable tools and
lawn and garden machinery - Safety - Part 1: General
requirements
(IEC 62841-1:2014 + corrigendum May 2014, modified)**

Outils électroportatifs à moteur, outils portables et machines
pour jardins et pelouses - Sécurité - Partie 1: Règles
générales
(IEC 62841-1:2014 + corrigendum May 2014, modifiée)

Elektrische motorbetriebene handgeführte Werkzeuge,
transportable Werkzeuge und Rasen- und
Gartenmaschinen - Sicherheit - Teil 1: Allgemeine
Anforderungen
(IEC 62841-1:2014 + corrigendum May 2014, modifiziert)

This European Standard was approved by CENELEC on 2015-06-15. CENELEC members are bound to comply with the CEN/CENELEC Internal Regulations which stipulate the conditions for giving this European Standard the status of a national standard without any alteration.

Up-to-date lists and bibliographical references concerning such national standards may be obtained on application to the CEN-CENELEC Management Centre or to any CENELEC member.

This European Standard exists in three official versions (English, French, German). A version in any other language made by translation under the responsibility of a CENELEC member into its own language and notified to the CEN-CENELEC Management Centre has the same status as the official versions.

CENELEC members are the national electrotechnical committees of Austria, Belgium, Bulgaria, Croatia, Cyprus, the Czech Republic, Denmark, Estonia, Finland, Former Yugoslav Republic of Macedonia, France, Germany, Greece, Hungary, Iceland, Ireland, Italy, Latvia, Lithuania, Luxembourg, Malta, the Netherlands, Norway, Poland, Portugal, Romania, Slovakia, Slovenia, Spain, Sweden, Switzerland, Turkey and the United Kingdom.



European Committee for Electrotechnical Standardization
Comité Européen de Normalisation Electrotechnique
Europäisches Komitee für Elektrotechnische Normung

CEN-CENELEC Management Centre: Avenue Marnix 17, B-1000 Brussels

Foreword

The text of document 116/156/FDIS, future edition 1 of IEC 62841-1, prepared by IEC/TC 116 "Safety of motor-operated electric tools" was submitted to the IEC-CENELEC parallel vote and approved by CENELEC as EN 62841-1:2015.

A draft amendment, which covers common modifications to IEC 62841-1, was prepared by CLC/TC 116 "Safety of motor-operated electric tools" and approved by CENELEC.

The following dates are fixed:

- latest date by which this document has to be implemented (dop) 2016-06-15
at national level by publication of an identical
national standard or by endorsement
- latest date by which the national standards conflicting (dow) -
with this document have to be withdrawn

The EN 62841 series supersedes the EN 60745 series, the EN 61029 series and (for lawn and garden machinery) parts of the EN 60335 series.

This European Standard replaces EN 60745-1:2009 and EN 61029-1:2009. However, EN 60745-1:2009 and EN 61029-1:2009 remain valid until all Part 2's which are used in conjunction with them have been withdrawn. No date of withdrawal (dow) has been given pending the updating of all the Part 2's to align with this EN 62841-1:2015 as respective Part 2's and Part 3's. The applicable date of withdrawal is given in each Part 2 and Part 3. It is intended the dow for this Part 1 will be fixed once all the Part 2's and Part 3's have been published.

EN 62841-1:2015 includes the following significant technical changes:

- requirements in various clauses introduced or modified in order to include the requirements for transportable tools and lawn and garden machinery (formerly covered by EN 61029-1 and EN 60335-1);
- leakage current test and electric strength test moved from former Clauses 13 and 15 to Annexes C and D;
- former Clauses 29, 30 and 31 renumbered to become Clauses 6, 13 and 15;
- requirements for electronic safety critical functions added to Clause 18;
- requirements for switches revised and moved from Annex I to Clause 23;
- clarifications in respect to soft materials (elastomers) added to Clauses 9, 19 and 13;
- test finger in Figure 1 of EN 60745-1 and test probe in Figure 2 of EN 60745-1 replaced by references to basic IEC standards;
- requirements for Li-ion battery systems added to Annexes K and L;
- Annex M removed.

Attention is drawn to the possibility that some of the elements of this document may be the subject of patent rights. CENELEC [and/or CEN] shall not be held responsible for identifying any or all such patent rights.

This document has been prepared under a mandate given to CENELEC by the European Commission and the European Free Trade Association and supports essential requirements of EU Directive(s).

For the relationship with EU Directive(s), see informative Annex ZZ, which is an integral part of this document.

This European Standard is divided into four parts:

Part 1: General requirements which are common to most electric motor operated tools (for the purpose of this standard referred to simply as tools) which could come within the scope of this standard;

Part 2, 3 or 4: Requirements for particular types of tools which either supplement or modify the requirements given in Part 1 to account for the particular hazards and characteristics of these specific tools.

This Part 1 is to be used in conjunction with the appropriate parts of EN 62841-2, EN 62841-3 or EN 62841-4 which contain clauses that supplements or modify the corresponding clauses in Part 1 to provide the relevant requirements for each type of product.

Compliance with the relevant clauses of Part 1 together with a relevant Part 2, 3 or 4 of this standard provides one means of conforming with the essential health and safety requirements of the Directive concerned.

A relevant Part 2, 3 or 4 is one in which the type of the tool or an accessory which is to be used with the tool is within the scope of that Part 2, 3 or 4.

When a relevant Part 2, 3, or 4 does not exist, Part 1 can help to establish the requirements for the tool, but will not by itself provide a means of conforming to the relevant essential health and safety requirements of the Machinery Directive.

Warning: Other requirements and other EU Directives can be applicable to the products falling within the scope of this standard.

CEN Technical Committees have produced a range of standards dealing with a similar range of non-electrically powered tools. Where necessary, normative references are made to these standards in the relevant Part 2, 3 or 4.

This European Standard follows the overall requirements of EN ISO 12100.

NOTE 1 In this standard, the following print types are used:

- requirements proper; in roman type
- *test specifications: in italic type;*
- explanatory matter: in smaller roman type.

Words in **bold** in the text are defined in Clause 3. When a definition concerns an adjective, the adjective and the associated noun are also in bold.

NOTE 2 In Annexes B, K and L, subclauses which are additional to those in the main body of the text are numbered starting from 201.

NOTE 3 Clauses, subclauses, notes, tables, figures and annexes which are additional to those in IEC 62841-1:2014 are prefixed "Z".

Endorsement notice

The text of the International Standard IEC 62841-1:2014 + corrigendum May 2014 was approved by CENELEC as a European Standard with agreed common modifications.

Annex ZA (normative)

Normative references to international publications with their corresponding European publications

The following documents, in whole or in part, are normatively referenced in this document and are indispensable for its application. For dated references, only the edition cited applies. For undated references, the latest edition of the referenced document (including any amendments) applies.

NOTE 1 When an International Publication has been modified by common modifications, indicated by (mod), the relevant EN/HD applies.

NOTE 2 Up-to-date information on the latest versions of the European Standards listed in this annex is available here: www.cenelec.eu

<u>Publication</u>	<u>Year</u>	<u>Title</u>	<u>EN/HD</u>	<u>Year</u>
IEC 60061	Series	Lamp caps and holders together with gauges for the control of interchangeability and safety	EN 60061	Series
IEC 60065 (mod) + corr. August + A1 (mod) + A2 (mod)	2001 2002 2005 2010	Audio, video and similar electronic apparatus - Safety requirements	EN 60065 + corr. August + A1 + A2	2002 ¹⁾ 2007 ¹⁾ 2006 ¹⁾ 2010 ¹⁾
-	-		+ A11	2008 ¹⁾
-	-		+ A12	2011 ¹⁾
IEC 60068-2-75	1997	Environmental testing Part 2-75: Tests - Test Eh: Hammer tests	EN 60068-2-75	1997 ²⁾
IEC/TR 60083	-	Plugs and socket-outlets for domestic and similar general use standardized in member countries of IEC	-	-
IEC 60085	2007	Electrical insulation - Thermal evaluation and designation	EN 60085	2008
IEC 60127	Series	Miniature fuses	EN 60127	Series
IEC 60227	Series	Polyvinyl chloride insulated cables of rated voltages up to and including 450/750 V	-	-
IEC 60238	-	Edison screw lampholders	EN 60238	-
IEC 60245	Series	Rubber insulated cables - Rated voltages up to and including 450/750 V	-	-
IEC 60252-1	-	AC motor capacitors Part 1: General - Performance, testing and rating - Safety requirements - Guidance for installation and operation	EN 60252-1	-
IEC 60320	Series	Appliance couplers for household and similar general purposes	EN 60320	Series

¹⁾ Superseded by EN 60065:2014 (IEC 60065:2014): DOW = 2017-11-17.

²⁾ Superseded by EN 60068-2-75:2014 (IEC 60068-2-75:2014): DOW = 2017-10-08. 

<u>Publication</u>	<u>Year</u>	<u>Title</u>	<u>EN/HD</u>	<u>Year</u>
IEC 60320-1	-	Appliance couplers for household and similar general purposes Part 1: General requirements	EN 60320-1	-
IEC 60335-1 (mod) + corr. July + corr. April	2010 2010 2011	Household and similar electrical appliances - Safety Part 1: General requirements	EN 60335-1	2012
IEC 60384-14	-	Fixed capacitors for use in electronic equipment Part 14: Sectional specification - Fixed capacitors for electromagnetic interference suppression and connection to the supply mains	EN 60384-14	-
IEC 60417 DB	-	Graphical symbols for use on equipment	-	-
IEC 60529 + A1 + A2	1989 1999 2013	Degrees of protection provided by enclosures (IP Code)	EN 60529 + corr. May + A1 + A2	1991 1993 2000 2013
IEC 60664-1	-	Insulation coordination for equipment within low-voltage systems Part 1: Principles, requirements and tests	EN 60664-1	-
IEC 60695-2-11 + corr. January	2000 2001	Fire hazard testing Part 2-11: Glowing/hot-wire based test methods - Glow-wire flammability test method for end-products	EN 60695-2-11	2001 ³⁾
IEC 60695-2-13 + corr. February	2010 2012	Fire hazard testing Part 2-13: Glowing/hot-wire based test methods - Glow-wire ignition temperature (GWIT) test method for materials	EN 60695-2-13	2010
IEC 60695-10-2 + corr. February	2003 2006	Fire hazard testing Part 10-2: Abnormal heat - Ball pressure test	EN 60695-10-2	2003 ⁴⁾
IEC 60695-11-10	2013	Fire hazard testing Part 11-10: Test flames - 50 W horizontal and vertical flame test methods	EN 60695-11-10	2013
IEC 60730-1 (mod)	2010	Automatic electrical controls for household and similar use Part 1: General requirements	EN 60730-1	2011
IEC 60825-1	2007	Safety of laser products Part 1: Equipment classification and requirements	EN 60825-1	2007 ⁵⁾
IEC 60884	Series	Plugs and socket-outlets for household and similar purposes	-	-
IEC 60906-1	-	IEC system of plugs and socket-outlets for household and similar purposes Part 1: Plugs and socket-outlets 16 A 250 V a.c.	-	-

³⁾ Superseded by EN 60695-2-11:2014 (IEC 60695-2-11:2014): DOW = 2017-03-13.

⁴⁾ Superseded by EN 60695-10-2:2014 (IEC 60695-10-2:2014): DOW = 2017-03-26.

⁵⁾ Superseded by EN 60825-1:2014 (IEC 60825-1:2014): DOW = 2017-06-19. 

<u>Publication</u>	<u>Year</u>	<u>Title</u>	<u>EN/HD</u>	<u>Year</u>
IEC 60990	1999	Methods of measurement of touch current and protective conductor current	EN 60990	1999
IEC 60998-2-1	-	Connecting devices for low-voltage circuits for household and similar purposes Part 2-1: Particular requirements for connecting devices as separate entities with screw-type clamping units	EN 60998-2-1	-
IEC 60998-2-2	-	Connecting devices for low-voltage circuits for household and similar purposes Part 2-2: Particular requirements for connecting devices as separate entities with screwless-type clamping units	EN 60998-2-2	-
IEC 60999-1	1999	Connecting devices - Electrical copper conductors - Safety requirements for screw-type and screwless-type clamping units Part 1: General requirements and particular requirements for clamping units for conductors from 0,2 mm ² up to 35 mm ² (included)	EN 60999-1	2000
IEC 61000-4-2	2008	Electromagnetic compatibility (EMC) Part 4-2: Testing and measurement techniques - Electrostatic discharge immunity test	EN 61000-4-2	2009
IEC 61000-4-3 + A1 + A2	2006 2007 2010	Electromagnetic compatibility (EMC) Part 4-3: Testing and measurement techniques - Radiated, radio-frequency, electromagnetic field immunity test	EN 61000-4-3 + A1 + A2	2006 2008 2010
IEC 61000-4-4	2012	Electromagnetic compatibility (EMC) Part 4-4: Testing and measurement techniques - Electrical fast transient/burst immunity test	EN 61000-4-4	2012
IEC 61000-4-5 + corr. October	2005 2009	Electromagnetic compatibility (EMC) Part 4-5: Testing and measurement techniques - Surge immunity test	EN 61000-4-5	2006 ⁶⁾
IEC 61000-4-6	2008	Electromagnetic compatibility (EMC) Part 4-6: Testing and measurement techniques - Immunity to conducted disturbances, induced by radio-frequency fields	EN 61000-4-6	2009 ⁷⁾
IEC 61000-4-11	2004	Electromagnetic compatibility (EMC) Part 4-11: Testing and measurement techniques - Voltage dips, short interruptions and voltage variations immunity tests	EN 61000-4-11	2004
IEC 61032 + corr. January	1997 2003	Protection of persons and equipment by enclosures - Probes for verification	EN 61032	1998

⁶⁾ Superseded by EN 61000-4-5:2014 (IEC 61000-4-5:2014); DOW: 2017-06-19.

⁷⁾ Superseded by EN 61000-4-6:2014 (IEC 61000-4-6:2014); DOW: 2016-11-27. 

<u>Publication</u>	<u>Year</u>	<u>Title</u>	<u>EN/HD</u>	<u>Year</u>
IEC 61056-1	-	General purpose lead-acid batteries (valve-regulated types) Part 1: General requirements, functional characteristics - Methods of test	EN 61056-1	-
IEC 61058-1 (mod) + corr. January + A1 + A2	2000 2009 2001 2007	Switches for appliances Part 1: General requirements	EN 61058-1 - + A2	2002 ⁸⁾ - 2008
IEC 61210	-	Connecting devices - Flat quick-connect terminations for electrical copper conductors - Safety requirements	EN 61210	-
IEC 61540 + A1 -	1997 1998 -		HD 639 S1 + corr. July + A2	2002 ⁹⁾ 2003 2010
IEC 61558-1	-	Safety of power transformers, power supplies, reactors and similar products Part 1: General requirements and tests	EN 61558-1	-
IEC 61558-2-4	-	Safety of transformers, reactors, power supply units and similar products for supply voltages up to 1 100 V Part 2-4: Particular requirements and tests for isolating transformers and power supply units incorporating isolating transformers	EN 61558-2-4	-
IEC 61558-2-6	-	Safety of transformers, reactors, power supply units and similar products for supply voltages up to 1 100 V Part 2-6: Particular requirements and tests for safety isolating transformers and power supply units incorporating safety isolating transformers	EN 61558-2-6	-
IEC 61558-2-16	-	Safety of transformers, reactors, power supply units and similar products for voltages up to 1 100 V Part 2-16: Particular requirements and tests for switch mode power supply units and transformers for switch mode power supply units	EN 61558-2-16	-
IEC 61951-1	-	Secondary cells and batteries containing alkaline or other non-acid electrolytes - Portable sealed rechargeable single cells Part 1: Nickel-cadmium	EN 61951-1	-
IEC 61951-2	-	Secondary cells and batteries containing alkaline or other non-acid electrolytes - Portable sealed rechargeable single cells Part 2: Nickel-metal hydride	EN 61951-2	-
IEC 61960	-	Secondary cells and batteries containing alkaline or other non-acid electrolytes - Secondary lithium cells and batteries for portable applications	EN 61960	-

⁸⁾ EN 61058-1 includes A1 to IEC 61058-1 (mod) + corr. January.

⁹⁾ HD 639 S1 includes A1 to IEC 61540. 

<u>Publication</u>	<u>Year</u>	<u>Title</u>	<u>EN/HD</u>	<u>Year</u>
IEC 61984	-	Connectors - Safety requirements and tests	EN 61984	-
IEC 62133	-	Secondary cells and batteries containing alkaline or other non-acid electrolytes - Safety requirements for portable sealed secondary cells, and for batteries made from them, for use in portable applications	EN 62133	-
IEC 62233	-	Measurement methods for electromagnetic fields of household appliances and similar apparatus with regard to human exposure	EN 62233	-
IEC 62471	-	Photobiological safety of lamps and lamp systems	EN 62471	-
IEC/TR 62471-2	2009	Photobiological safety of lamps and lamp systems Part 2: Guidance on manufacturing requirements relating to non-laser optical radiation safety	-	-
ISO 1463	-	Metallic and oxide coatings - Measurement of coating thickness - Microscopical method	EN ISO 1463	-
ISO 2178	-	Non-magnetic coatings on magnetic substrates - Measurement of coating thickness - Magnetic method	EN ISO 2178	-
ISO 2768-1	-	General tolerances Part 1: Tolerances for linear and angular dimensions without individual tolerance indications	EN 22768-1	-
ISO 3744	-	Acoustics - Determination of sound power levels and sound energy levels of noise sources using sound pressure - Engineering methods for an essentially free field over a reflecting plane	EN ISO 3744	-
ISO 3864-2	-	Graphical symbols - Safety colours and safety signs Part 2: Design principles for product safety labels	-	-
ISO 3864-3	-	Graphical symbols - Safety colours and safety signs Part 3: Design principles for graphical symbols for use in safety signs	-	-
ISO 4871	1996	Acoustics - Declaration and verification of noise emission values of machinery and equipment	EN ISO 4871	2009
ISO 5347	Series	Methods for the calibration of vibration and shock pick-ups	-	-
ISO 5349-1	-	Mechanical vibration - Measurement and evaluation of human exposure to hand-transmitted vibration Part 1: General requirements 	EN ISO 5349-1	-

<u>Publication</u>	<u>Year</u>	<u>Title</u>	<u>EN/HD</u>	<u>Year</u>
ISO 5349-2	-	Mechanical vibration - Measurement and evaluation of human exposure to hand-transmitted vibration Part 2: Practical guidance for measurement at the workplace	EN ISO 5349-2	-
ISO 7000	2012	Graphical symbols for use on equipment - Registered symbols	-	-
ISO 7010	-	Graphical symbols - Safety colours and safety signs - Registered safety signs	EN ISO 7010	-
ISO 7574-4	-	Acoustics - Statistical methods for determining and verifying stated noise emission values of machinery and equipment Part 4: Methods for stated values for batches of machines	EN 27574-4	-
ISO 8041	-	Human response to vibration - Measuring instrumentation	EN ISO 8041	-
ISO 9772	2012	Cellular plastics - Determination of horizontal burning characteristics of small specimens subjected to a small flame	-	-
ISO 11201	-	Acoustics - Noise emitted by machinery and equipment - Determination of emission sound pressure levels at a work station and at other specified positions in an essentially free field over a reflecting plane with negligible environmental corrections	EN ISO 11201	-
ISO 11203	-	Acoustics - Noise emitted by machinery and equipment - Determination of emission sound pressure levels at a work station and at other specified positions from the sound power level	EN ISO 11203	-
ISO/TR 11690-3	-	Acoustics - Recommended practice for the design of low noise workplaces containing machinery Part 3: Sound propagation and noise prediction in workrooms	EN ISO/TR 11690-3	-
ISO 12100	-	Safety of machinery - General principles for design - Risk assessment and risk reduction	EN ISO 12100	-
ISO 13849-1	-	Safety of machinery - Safety-related parts of control systems Part 1: General principles for design	EN ISO 13849-1	-
ISO 13850	-	Safety of machinery - Emergency stop - Principles for design	EN ISO 13850	-
ISO 16063-1	-	Methods for the calibration of vibration and shock transducers Part 1: Basic concepts	-	-
EN 12096	-	Mechanical vibration - Declaration and verification of vibration emission values	-	- 

<u>Publication</u>	<u>Year</u>	<u>Title</u>	<u>EN/HD</u>	<u>Year</u>
ASTM B 258		Standard specification for standard nominal diameters and cross-sectional areas of AWG sizes of solid round wires used as electrical conductors	-	-
UL 969		Standard for marking and labeling systems	-	- 

Ⓒ Annex ZZ
(informative)

Coverage of Essential Requirements of Directive 2006/42/EC

This European Standard has been prepared under a mandate given to CENELEC by the European Commission and the European Free Trade Association and within its scope the standard covers all relevant Essential Requirements as given in EU Directive 2006/42/EC (Machinery Directive).

Compliance with this standard provides one means of conformity with the specified essential requirements of the Directives concerned.

WARNING: Other requirements and other EU Directives may be applicable to the products falling within the scope of this standard.

NOTE Compliance with Part 1 and a relevant machine specific part of EN 62841-2, EN 62841-3 or EN 62841-4 is required to achieve presumption of conformity with the Essential Requirements as given in EU Directive 2006/42/EC. Ⓒ

CONTENTS

FOREWORD.....	15
INTRODUCTION.....	18
1 Scope.....	19
2 Normative references	20
3 Terms and definitions.....	25
4 General requirements	31
5 General conditions for the tests	31
6 Radiation, toxicity and similar hazards	34
7 Classification.....	35
8 Marking and instructions.....	35
9 Protection against access to live parts	46
10 Starting	48
11 Input and current	48
12 Heating	49
13 Resistance to heat and fire	53
14 Moisture resistance	54
15 Resistance to rusting	57
16 Overload protection of transformers and associated circuits	58
17 Endurance.....	58
18 Abnormal operation	59
19 Mechanical hazards.....	67
20 Mechanical strength	69
21 Construction	71
22 Internal wiring.....	81
23 Components	82
24 Supply connection and external flexible cords	87
25 Terminals for external conductors	93
26 Provision for earthing.....	95
27 Screws and connections	97
28 Creepage distances, clearances and distances through insulation.....	100
Annex A (normative) Measurement of creepage distances and clearances	107
Annex B (normative) Motors not isolated from the supply mains and having basic insulation not designed for the rated voltage of the tool	112
Annex C (normative) Leakage current.....	114
Annex D (normative) Electric strength.....	117
☐ Annex E Void ☐.....	119
Annex F (informative) Rules for routine tests	120
Annex G Void.....	122
Annex H (normative) Determination of a low-power circuit.....	123
Annex I ☐ (normative) ☐ Measurement of noise and vibration emissions	124
Annex J Void.....	139
Annex K (normative) Battery tools and battery packs	140

Annex L (normative) Battery tools and battery packs provided with mains connection or non-isolated sources.....	159
Bibliography.....	177
Figure 1 – Test fingernail.....	104
Figure 2 – Flexing test apparatus	105
Figure 3 – Overload test of a class II armature	106
Figure A.1 – Clearance gap for parallel sided and V-shaped groove.....	108
Figure A.2 – Clearance gap for rib and uncemented joint with groove	109
Figure A.3 – Clearance gap for uncemented joint and diverging-sided groove	110
Figure A.4 – Clearance gap between wall and screw	111
Figure B.1 – Simulation of fault conditions.....	113
Figure C.1 – Diagram for leakage current measurement for single-phase connection and three-phase tools suitable for single-phase supply.....	115
Figure C.2 – Diagram for leakage current measurement for three-phase connection	116
Figure C.3 – Circuit of the leakage current meter.....	116
Figure H.1 – Example of an electronic circuit with low-power points.....	123
Figure I.1 – Test bench	137
Figure I.2 – Positions of a hand-held power tool and microphones for the hemispherical / cylindrical measurement surface	137
Figure I.3 – Microphone positions on a cubic measurement surface	138
Figure I.4 – Directions of vibration measurement.....	138
Figure K.1 – Measurement of clearances.....	158
Figure L.1 – Measurement of clearances	176
Table 1 – Maximum normal temperature rises (1 of 2).....	51
Table 2 – Maximum outside surface temperature rises	53
Table 3 – Maximum winding temperature	60
Table 4 – Required performance levels.....	66
Table 5 – Impact energies	69
Table 6 – Test torques.....	70
Table 7 – Switch trigger force	75
Table 8 – Minimum cross-sectional area and AWG sizes of supply cords.....	89
Table 9 – Pull and torque value	91
Table 10 – Quick-connect terminals for earthing conductors.....	96
Table 11 – Torque for testing screws and nuts	98
Table 12 – Minimum creepage distances and clearances.....	101
Table D.1 – Test voltages	117
Table F.1 – Test voltages for the electric strength test.....	121
Table K.1 – Minimum creepage distances and clearances between parts of opposite polarity	157
Table L.1 – Minimum creepage distances and clearances between parts of opposite polarity	175

INTERNATIONAL ELECTROTECHNICAL COMMISSION

ELECTRIC MOTOR-OPERATED HAND-HELD TOOLS, TRANSPORTABLE TOOLS AND LAWN AND GARDEN MACHINERY – SAFETY –

Part 1: General requirements

FOREWORD

- 1) The International Electrotechnical Commission (IEC) is a worldwide organization for standardization comprising all national electrotechnical committees (IEC National Committees). The object of IEC is to promote international co-operation on all questions concerning standardization in the electrical and electronic fields. To this end and in addition to other activities, IEC publishes International Standards, Technical Specifications, Technical Reports, Publicly Available Specifications (PAS) and Guides (hereafter referred to as “IEC Publication(s)”). Their preparation is entrusted to technical committees; any IEC National Committee interested in the subject dealt with may participate in this preparatory work. International, governmental and non-governmental organizations liaising with the IEC also participate in this preparation. IEC collaborates closely with the International Organization for Standardization (ISO) in accordance with conditions determined by agreement between the two organizations.
- 2) The formal decisions or agreements of IEC on technical matters express, as nearly as possible, an international consensus of opinion on the relevant subjects since each technical committee has representation from all interested IEC National Committees.
- 3) IEC Publications have the form of recommendations for international use and are accepted by IEC National Committees in that sense. While all reasonable efforts are made to ensure that the technical content of IEC Publications is accurate, IEC cannot be held responsible for the way in which they are used or for any misinterpretation by any end user.
- 4) In order to promote international uniformity, IEC National Committees undertake to apply IEC Publications transparently to the maximum extent possible in their national and regional publications. Any divergence between any IEC Publication and the corresponding national or regional publication shall be clearly indicated in the latter.
- 5) IEC itself does not provide any attestation of conformity. Independent certification bodies provide conformity assessment services and, in some areas, access to IEC marks of conformity. IEC is not responsible for any services carried out by independent certification bodies.
- 6) All users should ensure that they have the latest edition of this publication.
- 7) No liability shall attach to IEC or its directors, employees, servants or agents including individual experts and members of its technical committees and IEC National Committees for any personal injury, property damage or other damage of any nature whatsoever, whether direct or indirect, or for costs (including legal fees) and expenses arising out of the publication, use of, or reliance upon, this IEC Publication or any other IEC Publications.
- 8) Attention is drawn to the Normative references cited in this publication. Use of the referenced publications is indispensable for the correct application of this publication.
- 9) Attention is drawn to the possibility that some of the elements of this IEC Publication may be the subject of patent rights. IEC shall not be held responsible for identifying any or all such patent rights.

International Standard IEC 62841-1 has been prepared by IEC technical committee 116: Safety of motor-operated electric tools.

This standard is scheduled to cancel and replace the fourth edition of IEC 60745-1, published in 2006, the first edition of IEC 61029-1, published in 1990, and the fifth edition of IEC 60335-1, published in 2010, only with respect to requirements concerning lawn and garden machinery. The latter publications remain valid until they are withdrawn. This standard constitutes a technical revision.

This edition includes the following significant technical changes with respect to the fourth edition of IEC 60745-1:

- requirements in various clauses introduced or modified in order to include the requirements for transportable tools and lawn and garden machinery (formerly covered by IEC 61029-1 and IEC 60335-1);

- leakage current test and electric strength test moved from former Clauses 13 and 15 to Annexes C and D;
- former Clauses 29, 30 and 31 renumbered to become Clauses 6, 13 and 15;
- requirements for electronic **safety critical functions** added to Clause 18;
- requirements for switches revised and moved from Annex I to Clause 23;
- clarifications in respect to soft materials (elastomers) added to Clauses 9, 19 and 13;
- test finger in Figure 1 of IEC 60745-1 and test probe in Figure 2 of IEC 60745-1 replaced by references to basic IEC standards;
- requirements for Li-Ion battery systems added to Annexes K and L;
- Annex M removed.

The text of this standard is based on the following documents:

FDIS	Report on voting
116/156/FDIS	116/163/RVD

Full information on the voting for the approval of this standard can be found in the report on voting indicated in the above table.

This publication has been drafted in accordance with the ISO/IEC Directives, Part 2.

This Part 1 is to be used in conjunction with the appropriate parts of IEC 62841-2, IEC 62841-3 or IEC 62841-4 which contain clauses that supplement or modify the corresponding clauses in Part 1 to provide the relevant requirements for each type of product.

NOTE 1 In this standard, the following print types are used:

- requirements: in roman type
- *test specification: in italic type*
- Notes: in smaller roman type

Words in **bold** in the text are defined in Clause 3. When a definition concerns an adjective, the adjective and the associated noun are also in bold.

NOTE 2 In Annexes B, K and L, subclauses which are additional to those in the main body of the text are numbered starting from 201.

A list of all parts of the IEC 62841 series, under the general title: *Electric motor-operated hand-held tools, transportable tools and lawn and garden machinery – Safety*, can be found on the IEC website.

The committee has decided that the contents of this publication will remain unchanged until the stability date indicated on the IEC web site under "<http://webstore.iec.ch>" in the data related to the specific publication. At this date, the publication will be

- reconfirmed,
- withdrawn,
- replaced by a revised edition, or
- amended.

NOTE 3 The attention of National Committees is drawn to the fact that equipment manufacturers and testing organizations may need a transitional period following publication of a new, amended or revised IEC publication in which to make products in accordance with the new requirements and to equip themselves for conducting new or revised tests.

It is the recommendation of the committee that the content of this publication be adopted for implementation nationally not earlier than 36 months from the date of publication.

INTRODUCTION

Individual countries may wish to consider the application of this Part 1 of IEC 62841, so far as is reasonable, to tools not mentioned in an individual part of IEC 62841-2, IEC 62841-3 or IEC 62841-4 and to tools designed on new principles.

Examples of standards dealing with non-safety aspects of **hand-held tools, transportable tools and lawn and garden machinery** are

- standards dealing with EMC aspects;
- standards dealing with environmental aspects.

ELECTRIC MOTOR-OPERATED HAND-HELD TOOLS, TRANSPORTABLE TOOLS AND LAWN AND GARDEN MACHINERY – SAFETY –

Part 1: General requirements

1 Scope

This International Standard deals with the safety of electric motor-operated or magnetically driven:

- **hand-held tools** (IEC 62841-2);
- **transportable tools** (IEC 62841-3);
- **lawn and garden machinery** (IEC 62841-4).

The above listed categories are hereinafter referred to as “tools” or “machines”.

The **rated voltage** is not more than 250 V for single-phase a.c. or d.c. tools, and 480 V for three-phase a.c. tools. The **rated input** is not more than 3 700 W.

The limits for the applicability of this standard for battery tools are given in K.1 and L.1.

This standard deals with the hazards presented by tools which are encountered by all persons in the **normal use** and reasonably foreseeable misuse of the tools.

Tools with electric heating elements are within the scope of this standard.

Requirements for motors not isolated from the supply, and having **basic insulation** not designed for the **rated voltage** of the tools, are given in Annex B. Requirements for rechargeable battery-powered motor-operated or magnetically driven tools and the battery packs for such tools are given in Annex K. Requirements for such tools that are also operated and/or charged directly from the mains or a non-isolated source are given in Annex L.

Hand-held electric tools, which can be mounted on a support or working stand for use as fixed tools without any alteration of the tool itself, are within the scope of this standard and such combination of a **hand-held tool** and a support is considered to be a **transportable tool** and thus covered by the relevant Part 3.

This standard does not apply to:

- tools intended to be used in the presence of explosive atmosphere (dust, vapour or gas);
- tools used for preparing and processing food;
- tools for medical purposes;

NOTE 1 IEC 60601 series covers a variety of tools for medical purposes.

- tools intended to be used with cosmetics or pharmaceutical products;
- heating tools;

NOTE 2 IEC 60335-2-45 covers a variety of heating tools.

- electric motor-operated household and similar electrical appliances;

NOTE 3 IEC 60335 series covers a variety of electric motor-operated household and similar electrical appliances.

- electrical equipment for industrial machine-tools;

NOTE 4 IEC 60204 series deals with electrical safety of machinery.

- small low voltage transformer operated bench tools intended for model making, e.g. the making of radio controlled model aircraft or cars, etc.

NOTE 5 In the United States of America, the following conditions apply:

This standard deals with tools used in non-hazardous locations in accordance with the National Electrical Code, NFPA 70.

NOTE 6 In Canada, the following conditions apply:

This standard deals with tools used in non-hazardous locations in accordance with the Canadian Electric Code, Part 1, CSA C22.1, and General Requirements – Canadian Electrical Code, Part II, CAN/CSA-C22.2 No. 0.

2 Normative references

The following documents, in whole or in part, are normatively referenced in this document and are indispensable for its application. For dated references, only the edition cited applies. For undated references, the latest edition of the referenced document (including any amendments) applies.

IEC 60061, *Lamp caps and holders together with gauges for the control of interchangeability and safety*, available at <http://std.iec.ch/iec60061>

IEC 60065:2001, *Audio, video and similar electronic apparatus – Safety requirements*¹
Amendment 2:2010
Amendment 1:2005

IEC 60068-2-75:1997, *Environmental testing – Part 2-75: Tests – Test Eh: Hammer tests*

IEC/TR 60083, *Plugs and socket-outlets for domestic and similar general use standardized in member countries of IEC*

IEC 60085:2007, *Electrical insulation – Thermal evaluation and designation*

IEC 60127 (all parts), *Miniature fuses*

IEC 60227 (all parts), *Polyvinyl chloride insulated cables of rated voltages up to and including 450/750 V*

IEC 60238, *Edison screw lampholders*

IEC 60245 (all parts), *Rubber insulated cables – Rated voltages up to and including 450/750 V*

IEC 60252-1, *AC motor capacitors – Part 1: General – Performance, testing and rating – Safety requirements – Guidance for installation and operation*

IEC 60320 (all parts), *Appliance couplers for household and similar general purposes*

IEC 60320-1, *Appliance couplers for household and similar general purposes – Part 1: General requirements*

IEC 60335-1:2010, *Household and similar electrical appliances – Safety – Part 1: General requirements*

¹ There exists a consolidated version (Edition 7.2:2011) which includes IEC 60065:2001 and its Amendment 1 (2005) and Amendment 2 (2010).

IEC 60384-14, *Fixed capacitors for use in electronic equipment – Part 14: Sectional specification – Fixed capacitors for electromagnetic interference suppression and connection to the supply mains*

IEC 60417, *Graphical symbols for use on equipment*, available at [http://www.graphical-symbols.info/graphical-symbols/equipment/db1.nsf/\\$enHome?OpenForm](http://www.graphical-symbols.info/graphical-symbols/equipment/db1.nsf/$enHome?OpenForm)

IEC 60529:1989, *Degrees of protection provided by enclosures (IP Code)*²
Amendment 1:1999
Amendment 2:2013

IEC 60664-1, *Insulation coordination for equipment within low-voltage systems – Part 1: Principles, requirements and tests*

IEC 60695-2-11:2000, *Fire hazard testing – Part 2-11: Glowing/hot-wire based test methods – Glow-wire flammability test method for end-products*

IEC 60695-2-13:2010, *Fire hazard testing – Part 2-13: Glowing/hot-wire based test methods – Glow-wire ignition temperature (GWIT) test method for materials*

IEC 60695-10-2:2003, *Fire hazard testing – Part 10-2: Abnormal heat – Ball pressure test*

IEC 60695-11-10:2013, *Fire hazard testing – Part 11-10: Test flames – 50 W horizontal and vertical flame test methods*

IEC 60730-1:2010, *Automatic electrical controls for household and similar use – Part 1: General requirements*

IEC 60825-1:2007, *Safety of laser products – Part 1: Equipment classification and requirements*

IEC 60884 (all parts), *Plugs and socket-outlets for household and similar purposes*

IEC 60906-1, *IEC system of plugs and socket-outlets for household and similar purposes – Part 1: Plugs and socket-outlets 16 A 250 V a.c.*

IEC 60990:1999, *Methods of measurement of touch current and protective conductor current*

IEC 60998-2-1, *Connecting devices for low-voltage circuits for household and similar purposes – Part 2-1: Particular requirements for connecting devices as separate entities with screw-type clamping units*

IEC 60998-2-2, *Connecting devices for low-voltage circuits for household and similar purposes – Part 2-2: Particular requirements for connecting devices as separate entities with screwless-type clamping units*

IEC 60999-1:1999, *Connecting devices – Electrical copper conductors – Safety requirements for screw-type and screwless-type clamping units – Part 1: General requirements and particular requirements for clamping units for conductors from 0,2 mm² up to 35 mm² (included)*

IEC 61000-4-2:2008, *Electromagnetic compatibility (EMC) – Part 4-2: Testing and measurement techniques – Electrostatic discharge immunity test*

² There exists a consolidated version (Edition 2.2:2013) which includes IEC 60529:1989 and its Amendment 1 (1999) and Amendment 2 (2013).

IEC 61000-4-3:2006, *Electromagnetic compatibility (EMC) – Part 4-3: Testing and measurement techniques – Radiated, radio-frequency, electromagnetic field immunity test*³
Amendment 1:2007
Amendment 2:2010

IEC 61000-4-4:2012, *Electromagnetic compatibility (EMC) – Part 4-4: Testing and measurement techniques – Electrical fast transient/burst immunity test*

IEC 61000-4-5:2005, *Electromagnetic compatibility (EMC) – Part 4-5: Testing and measurement techniques – Surge immunity test*

IEC 61000-4-6:2008, *Electromagnetic compatibility (EMC) – Part 4-6: Testing and measurement techniques – Immunity to conducted disturbances, induced by radio-frequency fields*

IEC 61000-4-11:2004, *Electromagnetic compatibility (EMC) – Part 4-11: Testing and measurement techniques – Voltage dips, short interruptions and voltage variations immunity tests*

IEC 61032:1997, *Protection of persons and equipment by enclosures – Probes for verification*

IEC 61056-1, *General purpose lead-acid batteries (valve-regulated types) – Part 1: General requirements, functional characteristics – Methods of test*

IEC 61058-1:2000, *Switches for appliances – Part 1: General requirements*⁴
Amendment 1:2001
Amendment 2:2007

IEC 61210, *Connecting devices – Flat quick-connect terminations for electrical copper conductors – Safety requirements*

IEC 61540:1997, *Electrical accessories – Portable residual current devices without integral overcurrent protection for household and similar use (PRCDs)*⁵
Amendment 1:1998

IEC 61558-1, *Safety of power transformers, power supplies, reactors and similar products – Part 1: General requirements and tests*

IEC 61558-2-4, *Safety of transformers, reactors, power supply units and similar products for supply voltages up to 1 100 V – Part 2-4: Particular requirements and tests for isolating transformers and power supply units incorporating isolating transformers*

IEC 61558-2-6, *Safety of transformers, reactors, power supply units and similar products for supply voltages up to 1 100 V – Part 2-6: Particular requirements and tests for safety isolating transformers and power supply units incorporating safety isolating transformers*

IEC 61558-2-16, *Safety of transformers, reactors, power supply units and similar products for supply voltages up to 1 100 V – Part 2-16: Particular requirements and tests for switch mode power supply units and transformers for switch mode power supply units*

³ There exists a consolidated version (Edition 3.2:2010) which includes IEC 61000-4-3:2006 and its Amendment 1 (2007) and Amendment 2 (2010).

⁴ There exists a consolidated version (Edition 3.2:2008) which includes IEC 61058-1:2000 and its Amendment 1 (2001) and Amendment 2 (2007).

⁵ There exists a consolidated version (Edition 1.1:1999) which includes IEC 61540:1997 and its Amendment 1 (2001).

IEC 61951-1, *Secondary cells and batteries containing alkaline or other non-acid electrolytes – Portable sealed rechargeable single cells – Part 1: Nickel-cadmium*

IEC 61951-2, *Secondary cells and batteries containing alkaline or other non-acid electrolytes – Portable sealed rechargeable single cells – Part 2: Nickel-metal hydride*

IEC 61960, *Secondary cells and batteries containing alkaline or other non-acid electrolytes – Secondary lithium cells and batteries for portable applications*

IEC 61984, *Connectors – Safety requirements and tests*

IEC 62133, *Secondary cells and batteries containing alkaline or other non-acid electrolytes – Safety requirements for portable sealed secondary cells, and for batteries made from them, for use in portable applications*

IEC 62233, *Measurement methods for electromagnetic fields of household appliances and similar apparatus with regard to human exposure*

IEC 62471, *Photobiological safety of lamps and lamp systems*

IEC/TR 62471-2:2009, *Photobiological safety of lamps and lamp systems – Part 2: Guidance on manufacturing requirements relating to non-laser optical radiation safety*

ISO 1463, *Metallic and oxide coatings – Measurement of coating thickness – Microscopical method*

ISO 2178, *Non-magnetic coatings on magnetic substrates – Measurement of coating thickness – Magnetic method*

ISO 2768-1, *General tolerances – Part 1: Tolerances for linear and angular dimensions without individual tolerance indications*

ISO 3744, *Acoustics – Determination of sound power levels and sound energy levels of noise sources using sound pressure – Engineering methods for an essentially free field over a reflecting plane*

ISO 3864-2, *Graphical symbols – Safety colours and safety signs – Part 2: Design principles for product safety labels*

ISO 3864-3, *Graphical symbols – Safety colours and safety signs – Part 3: Design principles for graphical symbols for use in safety signs*

ISO 4871:1996, *Acoustics – Declaration and verification of noise emission values of machinery and equipment*

ISO 5347 (all parts), *Methods for the calibration of vibration and shock pick-ups*

ISO 5349-1, *Mechanical vibration – Measurement and evaluation of human exposure to hand-transmitted vibration – Part 1: General requirements*

ISO 5349-2, *Mechanical vibration – Measurement and evaluation of human exposure to hand-transmitted vibration – Part 2: Practical guidance for measurement in the workplace*

ISO 7000:2012, *Graphical symbols for use on equipment – Index and synopsis*

ISO 7010, *Graphical symbols – Safety colours and safety signs – Registered safety signs*

ISO 7574-4, *Acoustics – Statistical methods for determining and verifying stated noise emission values of machinery and equipment – Part 4: Methods for stated values for batches of machines*

ISO 8041, *Human response to vibration – Measuring instrumentation*

ISO 9772:2012, *Cellular plastics – Determination of horizontal burning characteristics of small specimens subjected to a small flame*

ISO 11201, *Acoustics – Noise emitted by machinery and equipment – Determination of emission sound pressure levels at a work station and at other specified positions in an essentially free field over a reflecting plane with negligible environmental corrections*

ISO 11203, *Acoustics – Noise emitted by machinery and equipment – Determination of emission sound pressure levels at a work station and at other specified positions from the sound power level*

ISO 12100, *Safety of machinery – General principles for design – Risk assessment and risk reduction*

ISO 13849-1, *Safety of machinery – Safety-related parts of control systems – Part 1: General principles for design*

ISO 13850, *Safety of machinery – Emergency stop – Principles for design*

ISO/TR 11690-3, *Acoustics – Recommended practice for the design of low-noise workplaces containing machinery – Part 3: Sound propagation and noise prediction in workrooms*

ISO 16063-1, *Methods for the calibration of vibration and shock transducers – Part 1: Basic concepts*

EN 12096, *Mechanical vibration – Declaration and verification of vibration emission values*

ASTM B 258, *Standard specification for standard nominal diameters and cross-sectional areas of AWG sizes of solid round wires used as electrical conductors*

UL 969, *Standard for marking and labeling systems*

☐ CR 1030-1, *Hand-arm vibration – Guidelines for vibration hazards reduction – Part 1: Engineering methods by design of machinery*

EN ISO 11688-1, *Acoustics – Recommended practice for the design of low-noise machinery and equipment – Part 1: Planning (ISO/TR 11688-1) ☐*

NOTE 1 In the United States of America, the following normative reference applies:

US, Code of Federal Regulations (CFR) Title 21, *Food and Drugs*.

NOTE 2 In Canada, the following normative reference applies:

C.R.C., c. 1370, *Radiation Emitting Devices Regulations*

3 Terms and definitions

For the purposes of this document, the following terms and definitions apply.

Where the terms voltage and current are used, they imply the r.m.s. values, unless otherwise specified.

Where in this standard the expressions “with the aid of a tool”, “without the aid of a tool”, and “requires the use of a tool”, are used, the word “tool” means a hand tool, for example a screwdriver, which may be used to operate a screw or other fixing means.

3.1

accessible part

conductive part or surface of insulating materials that can be touched by means of the test probe B of IEC 61032:1997

3.2

accessory

device that is attached only to the output mechanism of the tool

3.3

adjustable guard

guard which is adjustable as a whole or which incorporates adjustable part(s). For manually adjustable guards, the adjustment remains fixed during a particular operation

3.4

all-pole disconnection

disconnection of all supply conductors except the protective earthing (grounding) conductor by a single initiating action

3.5

attachment

device attached to the housing or other component of the tool and which may or may not be attached to the output mechanism and does not modify the **normal use** of the tool within the scope of this standard

3.6

basic insulation

insulation applied to **live parts** to provide protection against electric shock. Insulation applied to **live parts** not intended to provide electric shock protection is considered to be insulation for functional purposes, such as magnet wire insulation

3.7

battery

assembly of one or more **cells** intended to provide electrical current to the tool

3.8

class I tool

tool in which protection against electric shock does not rely on basic, double or **reinforced insulation** only, but which includes an additional safety precaution in that conductive **accessible parts** are connected to the protective earthing conductor in the fixed wiring of the installation in such a way that conductive **accessible parts** cannot become live in the event of a failure of the **basic insulation**

Note 1 to entry: Also considered as **class I tools** are tools with **double insulation** and/or **reinforced insulation** throughout, but also having an earthing terminal or earthing contact.

3.9

class II tool

tool in which protection against electric shock does not rely on **basic insulation** only, but in which additional safety precautions, such as **double insulation** or **reinforced insulation**, are provided, there being no provision for protective earthing or reliance upon installation conditions

3.10

class III tool

tool in which protection against electric shock relies on supply at **safety extra-low voltage**, and in which voltages higher than those of **safety extra-low voltages** are not generated

3.11

class II construction

part of a tool for which protection against electric shock relies upon **double insulation** or **reinforced insulation**

3.12

class III construction

part of a tool for which protection against electric shock relies upon **safety extra-low voltage**, and in which voltages higher than those of **safety extra-low voltages** are not generated

3.13

clearance

shortest distance between two conductive parts, or between a conductive part and the outer surface of the enclosure, considered as though metal foil were pressed into contact with accessible surfaces of insulating material, measured through air

Note 1 to entry: Examples of **clearances** are given in Annex A.

3.14

control device

device used by the user to adjust and/or regulate an electrical or mechanical function of the tool

3.15

creepage distance

shortest path between two conductive parts, or between a conductive part and the outer surface of the enclosure, considered as though metal foil were pressed into contact with accessible surfaces of insulating material, measured along the surface of the insulating material

Note 1 to entry: Examples of **creepage distances** are given in Annex A.

3.16

detachable part

part which can be removed or opened without the aid of a tool, or a part which is removed in accordance with the instruction for use, except externally accessible brush caps, even if removal requires the use of a tool

Note 1 to entry: A non-detachable part is covered by the requirements of 21.22.

3.17

double insulation

insulation system comprising both **basic insulation** and **supplementary insulation**

3.18

electronic circuit

circuit incorporating at least one **electronic component**

3.19

electronic component

part in which conduction is achieved principally by electrons moving through a vacuum, gas or semiconductor, with the exclusion of neon indicators

Note 1 to entry: Examples of **electronic components** are diodes, transistors, triacs and monolithic integrated circuits. Resistors, capacitors and inductors are not considered **electronic components**.

3.20

explosion

failure that occurs, when an enclosure opens violently and major components are forcibly expelled in a manner that could result in injury

3.21

extra-low voltage

voltage supplied from a source within the tool and, which, when the tool is supplied at **rated voltage**, does not exceed 50 V between conductors and between conductors and earth

3.22

fixed guard

guard affixed in such a manner (e.g. by screws, nuts, welding) that it can only be opened or removed with the use of tools or by destruction of the affixing means

3.23

guard

physical barrier, designed as part of the tool, to provide protection

3.24

hand-held tool

tool intended to do mechanical work, with or without provisions for mounting on a support, and so designed that the motor and the machine form an assembly which can easily be brought to the place of operation, and which is either held or supported by hand or suspended during operation

Note 1 to entry: **Hand-held tools** include tools provided with a flexible shaft, the motor being either fixed or portable.

3.25

inherent operating cycle

repetitive operation of a tool designed in such a way that the complete cycle duration cannot be altered by the operator

3.26

interconnection cord

external flexible cord provided for electrical connections between two parts of a tool

3.27

lawn and garden machinery

tool for garden maintenance

3.28

liquid system

system that employs water or a water-based liquid from an external or integral supply that is used to perform the intended function of the tool

3.29

live part

any conductor or conductive part intended to be energized in **normal use**, including a neutral conductor

3.30

mean time to dangerous failure

MTTF_d

expectation of the mean time to dangerous failure

3.31

momentary power switch

power switch that does not remain in the “on” position when the actuating device is released

3.32

non-self-resetting thermal cut-out

thermal cut-out which requires a manual operation for resetting, or replacement of a part, in order to restore the current

Note 1 to entry: Manual operation also includes operation of the **power switch**.

3.33

non-isolated source

voltage source in which the output is not isolated from the mains supply by means of a **safety isolating transformer**

3.34

normal operation

conditions under which the tool is operated in **normal use** when it is connected to the power supply

3.35

normal use

use of a tool for which it is designed, taking into account the manufacturer's instructions

3.36

power switch

device that electrically activates the primary function of the tool in the “on” position and deactivates the same function of the tool in its “off” position

3.37

protective device

device, the operation of which prevents a hazardous situation under abnormal operation conditions

3.38

protective impedance

impedance connected between **live parts** and accessible conductive parts, and of value so that the current is limited to a safe value

3.39

rated current

current assigned to the tool by the manufacturer

3.40

rated frequency

frequency assigned to the tool by the manufacturer

3.41

rated frequency range

frequency range assigned to the tool by the manufacturer, expressed by its lower and upper limits

3.42**rated input**

input in watts assigned to the tool by the manufacturer

3.43**rated no-load speed**

no-load speed assigned to the tool by the manufacturer

3.44**rated voltage**

voltage assigned to the tool by the manufacturer. For three-phase supply, it is the voltage between phases

3.45**rated voltage range**

voltage range assigned to the tools by the manufacturer, expressed by its lower and upper limits

3.46**reinforced insulation**

insulation of **live parts** which provides a degree of protection against electric shock equivalent to **double insulation**

Note 1 to entry: Examples of **reinforced insulation** are a single layer or several layers which cannot be tested singly as **basic insulation** or **supplementary insulation**.

3.47**residual current device****RCD**

device intended to detect a diversion of current from a circuit in a way that may expose the user to an electric shock; in such conditions the device opens the circuit

Note 1 to entry: Such a device is also known as portable **residual current device** (PRCD), ground fault circuit interrupter (GFCI) or earth leakage circuit breaker (ELCB).

3.48**safety critical function****SCF**

function(s) required by this standard, the loss of which would cause the tool to function in such a manner as to expose the user to a risk that is in excess of the risk that is permitted by this standard under abnormal conditions

3.49**safety extra-low voltage**

voltage not exceeding a peak value of 42,4 V between conductors and between conductors and earth, the no-load voltage not exceeding a peak value of 50 V, in an electric circuit which has galvanic separation from the supplying electric power system by such means as a **safety isolating transformer** or a converter with separate windings, the insulation of which complies with **double insulation** or **reinforced insulation** requirements

3.50**safety isolating transformer**

transformer, the input winding of which is electrically separated from the output winding by an insulation at least equivalent to **double insulation** or **reinforced insulation**, and which is intended to supply a distribution circuit, a tool or other equipment at **safety extra-low voltage**

3.51**self-resetting thermal cut-out**

thermal cut-out which automatically restores the current after the relevant part of the tool has cooled down to a given value

3.52

supplementary insulation

independent insulation applied in addition to the **basic insulation**, in order to provide protection against electric shock in the event of a failure of the **basic insulation**

3.53

supply cord

flexible cord, for supply purposes, which is fixed to the tool

3.54

temperature limiter

temperature-sensing device, the operating temperature of which may be either fixed or adjustable, and which, during **normal operation**, operates by opening or closing a circuit when the temperature of the controlled part reaches a predetermined value

Note 1 to entry: This does not reverse this operation of opening or closing a circuit during the **normal operation** of the tool.

3.55

thermal cut-out

device which, during abnormal operation, limits the temperature of the controlled part by automatically opening the circuit, or by reducing the current, the setting of which cannot be altered by the user

3.56

thermal link

thermal cut-out which operates only once, and then requires partial or complete replacement

3.57

thermostat

temperature-sensing device, the operating temperature of which may be either fixed or adjustable; and which, during **normal operation**, keeps the temperature of the controlled part between certain limits by automatically opening and closing a circuit

3.58

transportable tool

tool that has the following characteristics:

- a) intended to be taken to various designated working areas. The tool performs work on the material that is either brought to the tool, the tool is mounted to the workpiece or the tool is placed in proximity of the workpiece;
- b) intended to be moved by one or two people, with or without simple devices to facilitate transportation, e.g. handles, wheels and the like;
- c) used in a stationary position set up on a bench, table, floor or incorporating a device that performs the function of a bench or table, with or without fixing, e.g. fast clamping devices, bolting and the like, or mounted to the workpiece;
- d) used under the control of an operator;
- e) either the workpiece or the tool is fed or introduced manually;
- f) not intended for continuous production or production line use;
- g) if mains operated, supplied with a flexible **supply cord** and plug

3.59

type X attachment

method of attachment of the **supply cord** specified by the manufacturer so that it can easily be replaced

3.60**type Y attachment**

method of attachment of the **supply cord** such that any replacement is intended to be made by the manufacturer, its service agent or similar qualified person

3.61**type Z attachment**

method of attachment of the **supply cord** so that it cannot be replaced without breaking or destroying the tool

3.62**user maintenance**

maintenance operation(s) which are intended to be carried out by the user in accordance with the instruction manual

3.63**working voltage**

maximum voltage, without the effect of transient voltages, to which the part under consideration is subjected when the tool is supplied at its **rated voltage** and operating with **rated input** or **rated current**

4 General requirements

Tools shall be so constructed that they operate safely so as to cause no danger to persons or surroundings.

Tools that have clearly separate modes of operation shall comply separately with the requirements applicable to each specific mode of operation.

 *Text deleted* 

Compliance is checked by fulfilling the relevant requirements and carrying out the relevant tests of this standard.

5 General conditions for the tests

5.1 *Tests according to this standard are type tests. General test conditions in Clause 5 apply unless otherwise specified in this standard.*

NOTE Annex F shows an example of routine tests.

5.2 *The tests are made on separate samples. However, at the manufacturer's discretion, fewer samples may be used.*

*The cumulative stress resulting from successive tests on **electronic circuits** is to be avoided. It may be necessary to replace components or to use additional samples.*

If several tests are conducted on a single sample, then the results shall not be affected by previous tests.

5.3 *If it is evident from the construction of the tool that a particular test is not applicable, the test is not made.*

5.4 *The tests are carried out with the tool, and/or any movable part of it, placed in the most unfavourable position that may occur in **normal use**.*

5.5 *Tools provided with controls or switching devices are tested with these controls or devices adjusted to their most unfavourable settings, if the setting can be altered by the user. Electronic speed **control devices** are set for the highest speed.*

If the adjusting means of the control is accessible without the aid of a tool, 5.5 applies whether the setting can be altered by hand or with the aid of a tool. If the adjusting means is not accessible without the aid of a tool, and if the setting is not intended to be altered by the user, 5.5 does not apply.

Adequate sealing is regarded as preventing alteration of the setting by the user.

5.6 *The tests are made in a draught-free location and at an ambient temperature of (20 ± 5) °C.*

If the temperature attained by any part is limited by a temperature sensitive device, the ambient temperature is, in case of doubt, maintained at (23 ± 2) °C.

5.7 *The test conditions related to frequency and voltage are specified in 5.7.1 to 5.7.3.*

5.7.1 *Tools for a.c. only are tested with a.c. at **rated frequency**, if marked, and those for a.c./d.c. are tested with the most unfavourable supply.*

*Tools for a.c. which are not marked with **rated frequency**, or marked with a **rated frequency range** of 50 Hz to 60 Hz or with 50/60 Hz, are tested with either 50 Hz or 60 Hz, whichever is the most unfavourable, unless the tool employs only series motors, in which case either frequency may be used.*

5.7.2 Tools having more than one **rated voltage** or having a **rated voltage range** are tested at the highest voltage.

5.7.3 For tests that require a value for **rated current** and with tools where there is no marked **rated current**, the value of the **rated current** is substituted by the current measured when the tool is operated at **rated input** at the lowest **rated voltage** or the lower value of the **rated voltage range**.

5.8 When alternative heating elements or **attachments** are made available for the tool by its manufacturer, the tool is tested with those heating elements or **attachments** which give the most unfavourable results.

5.9 Tools are tested with the specified flexible **supply cord** connected to the tool.

5.10 If **class I tools** have **accessible parts** which are not connected to an earthing terminal or earthing contact, and are not separated from **live parts** by an intermediate metal part which is connected to an earthing terminal or earthing contact, such parts are checked for compliance with the appropriate requirements specified for **class II construction**.

5.11 If **class I tools** or **class II tools** have parts operating at **safety extra-low voltage**, such parts are checked for compliance with the appropriate requirements specified for **class III tools**.

5.12 When testing **electronic circuits**, the supply is to be free from those perturbations from external sources that can influence the results of the tests.

5.13 If, in **normal use**, a heating element, if any, cannot be operated unless the motor is running, the element is tested with the motor running. If the heating element can be operated without the motor running, the element is tested with or without the motor running, whichever is the more unfavourable. Heating elements incorporated in the tool are connected to a separate supply unless otherwise specified.

5.14 For **attachments** performing a function which is within the scope of one of the relevant parts of IEC 62841-2, IEC 62841-3 or IEC 62841-4, the tests are made in accordance with that part of IEC 62841-2, IEC 62841-3 or IEC 62841-4.

5.15 If a torque is to be applied, the method of loading is chosen so as to avoid additional stresses, such as those caused by side thrust. Additional loads necessary for the correct operation of the tool are, however, taken into consideration.

If a brake is used for applying a load, it must be applied gradually to assure that the starting current does not affect the test. Modification of output means for purpose of loading is permitted for the connection to a brake.

5.16 Tools intended to be operated at **safety extra-low voltage** are tested using a supply transformer intended to be used with the tool.

5.17 If a requirement is based upon the mass of the tool, the mass shall be determined without **supply cord**, if any, and without tool bits or **accessories**, but with all equipment and **attachments** needed for **normal use**. Details of the required **accessories**, equipment and **attachments** are given in the relevant part of IEC 62841-2, IEC 62841-3 or IEC 62841-4.

If the tool is supplied with more than one **accessory**, equipment or **attachment**, the heaviest configuration shall be used to determine the mass.

5.18 *If linear and angular dimensions are specified without a tolerance, ISO 2768-1, class “c” is applicable.*

5.19 *All electrical measurements shall be made with a maximum measurement error of 5 %.*

Instruments for measuring voltage shall have an input resistance of at least 1 MΩ with a maximum parallel capacitance of 25 pF.

5.20 *Thermal equilibrium is considered achieved when the total deviation of three successive temperature rise readings, taken at 3 min intervals, does not exceed 4 K. For induction motors, a measurement time of 1 h is considered sufficient.*

For motors, thermal equilibrium may be evaluated by measuring the temperature of the stator laminations.

6 Radiation, toxicity and similar hazards

6.1 Tools shall not emit harmful radiation, or present a toxic or similar hazard.

Compliance is checked by the test, given in the relevant part of IEC 62841-2, IEC 62841-3 or IEC 62841-4, where necessary.

NOTE Previous studies have shown that the level of electromagnetic fields (EMF) emitted by power tools and garden machinery, measured in accordance with IEC 62233, is far below the applicable limits, provided the sole significant source of EMF is the motor, which is typically a universal, DC (with or without brushes), induction or solenoid motor. Therefore, a general measurement in accordance with IEC 62233 was regarded as not necessary.

6.2 If the tool is fitted with a laser to indicate a cutting line or the like, the laser class shall be 2M or lower, according to IEC 60825-1:2007.

In addition, the tool shall be marked with the symbol(s) as required by IEC 60825-1:2007 for the relevant laser class.

Compliance is checked by inspection.

6.3 If a tool is fitted with non-coherent light sources, users of tools shall be cautioned as to the risk of potential photo-biological harm, if such harm exists.

Depending on the type of light source, the requirements of 6.3.1, 6.3.2 or 6.3.3 apply.

6.3.1 Visible light indicators (pilot lamps) and Infrared sources used for signalling and communication are considered to have no risk of photo-biological harm and require no marking.

Compliance is checked by inspection.

6.3.2 Tools emitting visible light from electroluminescent, incandescent or LED sources are considered to be for short term, non-general light services use where exposure is both incidental and intermittent.

Tools emitting light from these sources shall be marked with one of the following:

- “**CAUTION** Do not stare at operating lamp”, or
- symbol IEC 60417-6041 (2010-08).

The marking may be omitted, if it can be demonstrated that the emitted light presents no reasonable risk of harm.

The emitted light is considered to present no reasonable risk or harm, if either

- the light emission at a distance of 200 mm along any direction of the tool is below 500 Lux; or
- the luminance light emission is less than 10 000 cd/m² in the range of visible light; or
- the light source (if not focused by external optics) is in Risk Group 1 or lower evaluated by the methods of IEC 62471; or
- the tool itself is evaluated by the methods of IEC 62471 and found to be in Risk Group 1 or lower.

Compliance is checked by measurement and by the methods specified in IEC 62471.

6.3.3 For light derived by sources other than those mentioned in 6.3.2, the product shall be evaluated by the methods of IEC 62471 and the markings shall be guided by 5.4 of IEC/TR 62471-2:2009.

Compliance is checked by inspection and by the methods specified in IEC 62471.

7 Classification

7.1 Tools shall be of one of the following classes with respect to protection against electric shock:

class I, class II, class III.

Compliance is checked by inspection and by the relevant tests.

7.2 Tools shall have the appropriate degree of protection against harmful ingress of water according to IEC 60529:2013. If a degree other than IPX0 is required this shall be specified in the relevant part of IEC 62841-2, IEC 62841-3 or IEC 62841-4.

Compliance is checked by inspection and by the relevant tests.

8 Marking and instructions

8.1 Tools shall be marked with rating information as follows:

- **rated voltage(s)** or **rated voltage range**, in volts. Tools for star-delta connection shall be clearly marked with the two **rated voltages** (for example 230 Δ/ 400 Y). A tool that complies with this standard for a voltage range, may also be marked with any single voltage or smaller voltage range within that range;
- symbol for nature of supply, unless the **rated frequency(ies)** or **rated frequency range** is marked. The symbol for nature of supply shall be placed next to the marking for **rated voltage**;
- **rated input**, in watts or **rated current**, in amperes. The **rated input** or **rated current** to be marked on the tool is the total maximum input or current that can be drawn from external circuit at the same time. If a tool has alternative components which can be selected by a **control device**, the **rated input** or **rated current** is that corresponding to the highest loading possible;
- symbol for **class II construction**, for **class II tools** only;
- IP number according to degree of protection against ingress of water other than IPX0. If the first numeral for the IP numbering is omitted, the omitted numeral shall be replaced by the letter X, for example IPX5.

Compliance is checked by inspection.

8.1.1 Tools having a range of rated values such as for voltage and frequency and which can be operated without adjustment throughout the range shall be marked with the lower and upper limits of the range separated by a hyphen.

Example:

115-230 V: The tool is suitable for any value within the marked range.

Tools having different rated values and which have to be adjusted for use of a particular value by the user or installer shall be marked with the different values separated by an oblique stroke. This requirement is also applicable to tools with provision for connection to both single-phase and multi-phase supplies.

Examples:

115/230 V: The tool is only suitable for the marked values.

230/400 V: The tool is only suitable for the voltages values indicated, 230 V being for single-phase operation and 400 V for three-phase operation.

Compliance is checked by inspection.

8.1.2 For tools marked with more than one **rated voltage**, a **rated voltage range** or with more than one **rated voltage range**, the **rated input** for each of these voltages shall be marked.

The upper and lower limits of the rated power input shall be marked on the tool so that the relation between input and voltage appears distinctly, unless the difference between the upper and lower limits of a **rated voltage range** does not exceed 20 % of the mean value of the range, in which case the marking for **rated input** may be related to the mean value of the range.

Compliance is checked by inspection.

8.2 Tools shall be marked with a safety warning in one of the following versions:

- “ WARNING – To reduce the risk of injury, user must read instruction manual”, or
- symbol M002 of ISO 7010, or
- the appropriate symbol stated in the relevant part of IEC 62841-2, IEC 62841-3 or IEC 62841-4.

If used, the word “WARNING” shall be in capital letters not less than 2,4 mm high and shall not be separated from either the cautionary statement or the symbol ISO 7000-0434A or ISO 7000-0434B (2004-01).

If used, the statement shall be verbatim except the term “operator’s manual” or “user guide” may be used for the term “instruction manual”.

If additional symbols are used, they shall be in accordance with ISO 7010 or be designed in accordance with ISO 3864-2 or ISO 3864-3.

Cautionary statements having the same signal word such as “ WARNING” may be combined into one paragraph under one signal word. The order of statements shall be markings required by IEC 62841-1, markings required by the relevant part of IEC 62841-2, IEC 62841-3 or IEC 62841-4 and then any optional markings.

Compliance is checked by inspection and by measurement.

8.3 Tools shall be marked with additional information as follows:

- the business name and address of the manufacturer and, where applicable, his authorised representative. Any address shall be sufficient to ensure contact. Country or state, city and postal code (if any) are deemed sufficient for this purpose;
- designation of the tool, designation of the tool may be achieved by a code that is any combination of letters, numbers or symbols, providing that this code is explained by giving the explicit designation such as “drill”, “planer” etc. in the instructions supplied with the tool;

NOTE 1 An example of such code is “A123-B”.

- designation of series or type, allowing the technical identification of the product. This may be achieved by a combination of letters and/or numbers and may be combined with the designation of tool;

NOTE 2 The term “designation of series or type” is also known as model number.

- the year of manufacture and a date code identifying at least the month of manufacture;
- for tools manufactured such that its parts are shipped separately for assembly by the end user, each part shall be marked with a distinct identification on the part or the package;
- “> 25 kg” if the mass of the tool is over 25 kg.

If additional markings are used, they shall not give rise to misunderstanding.

Compliance is checked by inspection.

8.4 Markings specified in 8.1 to 8.3 shall not be on a **detachable part** of the tool.

- ☐ Markings specified in 8.2 and 8.3 shall be clearly discernible from the outside of the tool. Other markings on the tool may be visible after removal of a cover, provided that the location of the markings is readily accessible. ☐

Indications for switches and controls shall be placed on or in the vicinity of these components; they shall not be placed on parts which can be repositioned, or positioned in such a way that the marking is misleading.

Compliance is checked by inspection.

8.5 If the tool can be adjusted to suit different **rated voltages**, the voltage to which the tool is adjusted shall be clearly discernible.

This requirement does not apply to tools for star-delta connection.

For tools where frequent changes in voltage setting are not required, this requirement is considered to be met if the **rated voltage** to which the tool is adjusted can be determined from a wiring diagram fixed to the tool. The wiring diagram may be on the inside of a cover which has to be removed to connect the supply conductors. It shall not be on a label loosely attached to the tool.









Compliance is checked by inspection.

8.6 For units the following shall be used:

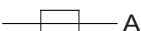
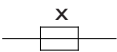
- V volts
- A amperes
- Ah ampere-hours
- Hz hertz

W	watts
kW	kilowatts
F	farads
μF	microfarads
l	litres
g	grams
kg.....	kilograms
bar	bars
Pa	pascals
h	hours
min.....	minutes
s.....	seconds
n ₀	no-load speed
.../min or ...min ⁻¹	revolutions or reciprocations per minute (rpm)

For symbols the following shall be used:

 or d.c.[symbol IEC 60417-5031 (2002-10)] direct current
 or a.c.[symbol IEC 60417-5032 (2002-10)] alternating current
3 three-phase alternating current
3Nthree-phase alternating current with neutral
 Arated current of the appropriate fuse-link in amperes
time-lag miniature fuse-link where X is the symbol for the time/current characteristic, as given in IEC 60127
[symbol IEC 60417-5019 (2006-08)] protective earth
[symbol IEC 60417-5172 (2003-02)] class II tool
IPXXIP symbol
[symbol ISO 7000-0434A or ISO 7000-0434B (2004-01)] caution
[symbol M002 of ISO 7010] read the instructions
[symbol IEC 60417-5012 (2002-10)] lamp
	NOTE The rated wattage of the lamp may be indicated in association with this symbol.
[symbol IEC 60417-6041 (2010-08)] visible radiation, instructional safeguard
∅diameter
Li-Ionlithium-ion battery

NiCdnickel-cadmium battery
NiMHnickel-metal hydride battery

If additional symbols are used, they shall not give rise to misunderstanding and be explained in the instructions.

When other units are used, the units and their symbols shall be those of the international standardized system.

Compliance is checked by inspection.

8.7 Tools to be connected to more than two supply conductors shall be provided with a connection diagram, fixed to the tool, unless the terminals are clearly identified.

The earthing conductor is not considered to be a supply conductor. For tools for star-delta connection, the wiring diagram shall show how the windings are to be connected.

Compliance is checked by inspection.

8.8 Except for **type Z attachment**, terminals shall be indicated as follows:

- Terminals intended exclusively for the neutral conductor shall be indicated by the letter N.
- Earthing terminals shall be indicated by the symbol IEC 60417-5019 (2006-08).

These indications shall not be placed on screws, removable washers or other parts which might be removed when conductors are being connected.

Compliance is checked by inspection.

8.9 Switches which may give rise to a hazard when operated shall be marked or so placed as to indicate clearly which part of the tool they control.

Compliance is checked by inspection.

8.10 The "off" position of a multi-stable **power switch** shall be indicated; the indication shall be the figure ○, as given by symbol IEC 60417-5008 (2002-10). A **momentary power switch** which can be locked in the "on" position is not considered as a multi-stable switch.

Push-buttons used only for the "off" function shall be indicated by marking the button/position with the figure ○ and the colour of the button shall be red or black.

The figure ○ shall not be used for any other indication.

NOTE The figure ○ can, for example, also be used on a digital programming keyboard.

For **transportable tools**, a power switch actuator or its cover shall not have a colour in a combination of yellow and red as specified for an emergency stop in accordance with ISO 13850.

When a flap/cover is provided and covers only the start button, the colour of the flap/cover shall not be black, red or yellow.

When a flap/cover is provided and covers the stop button, such flap/cover shall be red or black.

Compliance is checked by inspection.

8.11 Control devices intended to be adjusted during operation, shall be provided with an indication for the direction of adjustment to increase or to decrease the value of the characteristic being adjusted. An indication of + and – is considered to be sufficient for this requirement.

The requirement does not apply to **control devices** provided with an adjusting means, if its fully “on” position is opposite to its “off” position.

If figures are used for indicating the different positions, the “off” position shall be indicated by the figure 0 and the other positions shall be indicated by figures reflecting the greater output, input, speed, etc.

The indication for the different positions of the operating means of a **control device** shall be placed on the device itself, or adjacent to the operating means.

Compliance is checked by inspection.

8.12 Markings required by the standard shall be legible and durable. Signs shall be in contrast such as colour, texture, or relief, to their background such that the information or instructions provided by the signs are clearly legible when viewed with normal vision from a distance of (500 + 50) mm. Signs need not be in accordance with the blue colour requirements of ISO 3864-2.

Compliance is checked by inspection and by rubbing the marking by hand for 15 s with a piece of cloth soaked with water and again for 15 s with a piece of cloth soaked with petroleum spirit.

After the tests of 8.12, the marking shall be easily legible, it shall not be easily possible to remove markings.

*In considering the durability of the marking, the effect of **normal use** is taken into account. Thus, for example, marking by means of paint or enamel other than vitreous enamel on containers that are likely to be cleaned frequently is not considered to be durable.*

The petroleum spirit to be used for the test shall be a reagent grade hexane with a minimum of 85 % as n-hexane.

NOTE The designation “n-hexane” is the chemical nomenclature for a “normal” or straight chain hydrocarbon. An example of this petroleum spirit is also known as a certified ACS (American Chemical Society) reagent grade hexane (CAS #110-54-3).

If the marking has an adhesive backing, the adhesive backing shall be durable.

Compliance is checked by either meeting the requirements of UL 969 under the conditions of occasional exposure to oil, humidity and water, and appropriate for the surface to which it is applied, or by the following tests.

- *Three labels applied to the tools or a panel of the test surface material are placed in an oven for a minimum of 24 h with the oven is maintained at a temperature of (120 ± 2) °C, or alternatively for a minimum of 200 h at the temperature that the label is exposed to during the test of Clause 12.*
- *Six additional labels applied to the tool or a panel of the test surface material are placed in a controlled atmosphere maintained at 21 °C to 30 °C with a relative humidity of minimum 45 % for at least 24 h. After this conditioning, immerse three labels in water and the other three labels in IRM 903 oil at a temperature of 21 °C to 30 °C for 48 h.*
- *Three additional labels applied to the tool or a panel of the test surface material are placed in a controlled atmosphere maintained at 21 °C to 30 °C with a relative humidity of minimum 45 % for 72 h.*

After these conditionings, it shall not be easy to remove the label by scraping across the label with a flat steel blade of 0,8 mm thickness and any convenient width, held at right angles, and the label shall show no signs of curling.

8.13 If compliance with this standard depends upon the operation of a replaceable **thermal link** or fuse-link, the reference number or other means for identifying the link shall be marked on the link, or in a place that it is clearly visible after the link has failed, when the tool has been dismantled to the extent necessary for replacing the link.

This requirement does not apply to links which can only be replaced together with a part of the tool.

Compliance is checked by inspection.

8.14 An instruction manual and safety instructions shall be provided with the tool and packaged in such a way that is noticed by the user when the tool is removed from the packaging. An explanation of the symbols required by this standard and used on the tool shall be provided in either the instruction manual or the safety instructions.

They shall be written in the official language(s) of the country in which the tool is sold.

☐ The words “Original instructions” shall appear on the language version(s) verified by the manufacturer or his authorised representative. Where no “Original instructions” exist in the official language(s) of the country where the tool is to be used, a translation into that/those language(s) shall be provided by the manufacturer or his authorised representative or by the person bringing the tool into the language area in question. The translations shall bear the words “Translation of the original instructions”, and they shall be accompanied by a copy of the “Original instructions”. ☐

They shall be legible and contrast with the background.

They shall include the business name and address of the manufacturer and, where applicable, his authorised representative. Any address shall be sufficient to ensure contact. Country or state, city and postal code (if any) are deemed sufficient for this purpose.

They shall include the designation of the tool and series or type as required by 8.3, including description of machine such as “drill”, “planer” etc.

8.14.1 The subjects of safety instructions are the “General Power Tool Safety Warnings” of Part 1 as given in 8.14.1.1, the specific tool safety warnings of the relevant part of IEC 62841-2, IEC 62841-3 or IEC 62841-4 and any additional safety warning statements deemed necessary by the manufacturer. The “General Power Tool Safety Warnings” and the specific tool safety warnings, if in English, shall be verbatim and in any other official language to be equivalent. The numbering of the safety instructions, as given below, is not mandatory and may be omitted or replaced by other sorting means such as bullets. The “General Power Tool Safety Warnings” may be separate from the instruction manual.

As the term “power tool” or “tool” is not appropriate for **lawn and garden machinery**, for these products an appropriate term such as “machine” may be used.

The term verbatim means word-for-word but permits the differences in spelling between English-speaking countries.

Format of all safety warnings must differentiate, by font, highlighting or similar means, the context of clauses as illustrated below.

All notes in the safety instructions are not to be printed, they are information for the designer of the manual.

8.14.1.1 General power tool safety warnings

⚠ WARNING Read all safety warnings, instructions, illustrations and specifications provided with this power tool. *Failure to follow all instructions listed below may result in electric shock, fire and/or serious injury.*

Save all warnings and instructions for future reference.

The term "power tool" in the warnings refers to your mains-operated (corded) power tool or battery-operated (cordless) power tool.

1) Work area safety

- a) **Keep work area clean and well lit.** *Cluttered or dark areas invite accidents.*
- b) **Do not operate power tools in explosive atmospheres, such as in the presence of flammable liquids, gases or dust.** *Power tools create sparks which may ignite the dust or fumes.*
- c) **Keep children and bystanders away while operating a power tool.** *Distractions can cause you to lose control.*

2) Electrical safety

- a) **Power tool plugs must match the outlet. Never modify the plug in any way. Do not use any adapter plugs with earthed (grounded) power tools.** *Unmodified plugs and matching outlets will reduce risk of electric shock.*
- b) **Avoid body contact with earthed or grounded surfaces, such as pipes, radiators, ranges and refrigerators.** *There is an increased risk of electric shock if your body is earthed or grounded.*
- c) **Do not expose power tools to rain or wet conditions.** *Water entering a power tool will increase the risk of electric shock.*
- d) **Do not abuse the cord. Never use the cord for carrying, pulling or unplugging the power tool. Keep cord away from heat, oil, sharp edges or moving parts.** *Damaged or entangled cords increase the risk of electric shock.*
- e) **When operating a power tool outdoors, use an extension cord suitable for outdoor use.** *Use of a cord suitable for outdoor use reduces the risk of electric shock.*
- f) **If operating a power tool in a damp location is unavoidable, use a residual current device (RCD) protected supply.** *Use of an RCD reduces the risk of electric shock.*

NOTE The term "residual current device (RCD)" can be replaced by the term "ground fault circuit interrupter (GFCI)" or "earth leakage circuit breaker (ELCB)".

3) Personal safety

- a) **Stay alert, watch what you are doing and use common sense when operating a power tool. Do not use a power tool while you are tired or under the influence of drugs, alcohol or medication.** *A moment of inattention while operating power tools may result in serious personal injury.*
- b) **Use personal protective equipment. Always wear eye protection.** *Protective equipment such as a dust mask, non-skid safety shoes, hard hat or hearing protection used for appropriate conditions will reduce personal injuries.*
- c) **Prevent unintentional starting. Ensure the switch is in the off-position before connecting to power source and/or battery pack, picking up or carrying the tool.** *Carrying power tools with your finger on the switch or energising power tools that have the switch on invites accidents.*
- d) **Remove any adjusting key or wrench before turning the power tool on.** *A wrench or a key left attached to a rotating part of the power tool may result in personal injury.*
- e) **Do not overreach. Keep proper footing and balance at all times.** *This enables better control of the power tool in unexpected situations.*

- f) **Dress properly. Do not wear loose clothing or jewellery. Keep your hair and clothing away from moving parts.** *Loose clothes, jewellery or long hair can be caught in moving parts.*
- g) **If devices are provided for the connection of dust extraction and collection facilities, ensure these are connected and properly used.** *Use of dust collection can reduce dust-related hazards.*
- h) **Do not let familiarity gained from frequent use of tools allow you to become complacent and ignore tool safety principles.** *A careless action can cause severe injury within a fraction of a second.*

4) Power tool use and care

- a) **Do not force the power tool. Use the correct power tool for your application.** *The correct power tool will do the job better and safer at the rate for which it was designed.*
- b) **Do not use the power tool if the switch does not turn it on and off.** *Any power tool that cannot be controlled with the switch is dangerous and must be repaired.*
- c) **Disconnect the plug from the power source and/or remove the battery pack, if detachable, from the power tool before making any adjustments, changing accessories, or storing power tools.** *Such preventive safety measures reduce the risk of starting the power tool accidentally.*
- d) **Store idle power tools out of the reach of children and do not allow persons unfamiliar with the power tool or these instructions to operate the power tool.** *Power tools are dangerous in the hands of untrained users.*
- e) **Maintain power tools and accessories. Check for misalignment or binding of moving parts, breakage of parts and any other condition that may affect the power tool's operation. If damaged, have the power tool repaired before use.** *Many accidents are caused by poorly maintained power tools.*
- f) **Keep cutting tools sharp and clean.** *Properly maintained cutting tools with sharp cutting edges are less likely to bind and are easier to control.*
- g) **Use the power tool, accessories and tool bits etc. in accordance with these instructions, taking into account the working conditions and the work to be performed.** *Use of the power tool for operations different from those intended could result in a hazardous situation.*
- h) **Keep handles and grasping surfaces dry, clean and free from oil and grease.** *Slippery handles and grasping surfaces do not allow for safe handling and control of the tool in unexpected situations.*



5) Service

- a) **Have your power tool serviced by a qualified repair person using only identical replacement parts.** *This will ensure that the safety of the power tool is maintained.*

8.14.1.2 The order of the safety warnings shall be in accordance with either item A) or B) and in accordance with item C):

- A) The IEC 62841-1 warnings are followed by the relevant part of IEC 62841-2, IEC 62841-3 or IEC 62841-4 warnings. The order of the warnings within IEC 62841-1 and the IEC 62841-2, IEC 62841-3 or IEC 62841-4 warnings shall remain as given above and in the relevant part of IEC 62841-2, IEC 62841-3 or IEC 62841-4.
- B) The IEC 62841-1 and the IEC 62841-2, IEC 62841-3 or IEC 62841-4 warnings may be divided into the sections defined by the numbered subtitles and the associated warnings below the numbered subtitle. The order of warnings within each section shall remain as given above and in the relevant part of IEC 62841-2, IEC 62841-3 or IEC 62841-4.

When warnings are presented in this manner, the title of the IEC 62841-1 "General Power Tool Safety Warnings" shall be omitted and the 1st sentence of the warnings in 8.14.1.1 and 8.14.1.3, if applicable, shall be modified as follows:

 **WARNING** Read all safety warnings designated by the  symbol and all instructions.

The sections of the safety warnings shall be presented in the related topic of the instruction manual.

The instruction manual section titles for IEC 62841-1 warnings shall have a format:

 General Power Tool Safety Warnings – [Section subtitle]

Example:

 General Power Tool Safety Warnings – Personal Safety

The instruction manual section titles for IEC 62841-2, IEC 62841-3 or IEC 62841-4 warnings shall have a format:

 [Tool category name] Safety Warnings – [Section subtitle]

Example:

 Circular Saw Safety Warnings – Cutting Procedures

If particular IEC 62841-2, IEC 62841-3 or IEC 62841-4 warnings do not have a numbered subtitle, then all warnings required by the particular IEC 62841-2, IEC 62841-3 or IEC 62841-4 shall be presented in the given order and the formatting rule above shall be followed without the [Section subtitle].

- C) Any additional warnings deemed necessary by the manufacturer, shall not be inserted within any of the IEC 62841-1 or IEC 62841-2, IEC 62841-3 or IEC 62841-4 warnings. They may be either appended to the section(s) of the IEC 62841-1 or IEC 62841-2, IEC 62841-3 or IEC 62841-4 in accordance with the topic of the safety warnings or located in any other part of the instruction manual.

8.14.1.3 If the safety instructions are separate from the instruction manual, then the following warnings shall be included in the instruction manual. These warnings, if in English, shall be verbatim and in any other official language to be equivalent.

 WARNING Read all safety warnings, instructions, illustrations and specifications provided with this power tool. *Failure to follow all instructions listed below may result in electric shock, fire and/or serious injury.*

Save all warnings and instructions for future reference.

8.14.2 The instruction manual shall be provided with the following, if appropriate.

- a) Instructions for putting into use
- 1) Setting-up or fixing power tools in a stable position as appropriate for power tools which can be mounted on a support or fixed to a bench or the floor;
 - 2) Assembly;
 - 3) Connection to power supply, cabling, fusing, socket type and earthing requirements;
 - 4) For tools adjustable to different **rated voltages**: instructions, illustrations, or both for changing the voltage. The terminal identification shall be provided if the motor connection has to be altered to operate at a voltage other than that for which it was connected when shipped from the factory;
 - 5) Illustrated description of functions;
 - 6) Limitations on ambient conditions;
 - 7) Fitting and adjusting of **guards** required by 19.1;
 - 8) Information about disassembly and reassembly if applicable for transportation and/or use.
- b) Operating instructions
- 1) Setting and testing;
 - 2) Tool changing;
 - 3) Clamping of the workpiece;

- 4) Limits on size of workpiece and type of material;
 - 5) General instructions for use;
 - 6) Identification of handle(s) and grasping surface(s) required by 19.4;
 - 7) For tools with electronic speed or load regulators which do not immediately restart the tool after a stalling: a warning that the tool will restart automatically if stalled;
 - 8) For **transportable tools** only: instruction on lifting and transportation.
- c) Maintenance and servicing instructions
- 1) **User maintenance**, such as cleaning, sharpening, lubricating, servicing and/or replacing of parts;
 - 2) Servicing by manufacturer or agent; list of addresses;
 - 3) List of user-replaceable parts and instruction how to replace them;
 - 4) Special tools which may be required;
 - 5) For power tools with **type X attachment**: instruction that, if the **supply cord** of this power tool is damaged, it must be replaced by a specially prepared **supply cord** available through the service organization;
 - 6) For power tools with **type Y attachment**: instruction that, if the replacement of the **supply cord** is necessary, this has to be done by the manufacturer or his agent in order to avoid a safety hazard;
 - 7) For power tools with **type Z attachment**: information that the **supply cord** of this power tool cannot be replaced, and the power tool shall be scrapped.
- d) For tools with a **liquid system**, the substance of the following, as appropriate:
- 1) Instructions for
 - the connection to the liquid supply;
 - the use of the liquid and the use of **attachments** to comply with 14.3 in order to
 - avoid the tool being affected by the liquid;
 - the inspection of hoses and other critical parts which could deteriorate;
 - the maximum permitted pressure of the liquid supply;
 - 2) For tools provided with an **RCD**
 - warning never to use the tool without the **RCD** provided with the tool;
 - instruction always to test the correct operation of the **RCD** before starting work, unless the **RCD** is of a self-checking type;
 - 3) For tools for use in combination with an isolating transformer: warning never to use the tool without the transformer delivered with the tool or of the type as specified in these instructions;
 - 4) Instruction that replacement of the plug or the **supply cord** shall always be carried out by the manufacturer of the tool or his service organization;
 - 5) Instruction to keep liquid clear of the parts of the tool and away from persons in the working area.

Ⓢ Za) Emissions

- 1) The noise emission, measured in accordance with I.2, as follows:
 - A-weighted emission sound pressure level L_{pA} and its uncertainty K_{pA} , where L_{pA} exceeds 70 dB(A).
Where L_{pA} does not exceed 70 dB(A), this fact shall be indicated;
 - A-weighted sound power level L_{WA} and its uncertainty K_{WA} , where the A-weighted emission sound pressure level L_{pA} exceeds 80 dB(A);
 - C-weighted peak emission sound pressure level L_{pCpeak} , where this exceeds 63 Pa (130 dB in relation to 20 μ Pa). Ⓢ

- Ⓒ 2) Recommendation for the operator to wear hearing protection.
- 3) The vibration total value and its uncertainty measured in accordance with I.3.
When the vibration total value does not exceed 2,5 m/s², this shall be stated.
When the vibration total value exceeds 2,5 m/s², its value shall be given in the instructions.
- 4) The following information:
- that the declared vibration total value(s) and the declared noise emission value(s) have been measured in accordance with a standard test method and may be used for comparing one tool with another;
 - that the declared vibration total value(s) and the declared noise emission value(s) may also be used in a preliminary assessment of exposure.
- 5) A warning:
- that the vibration and noise emissions during actual use of the power tool can differ from the declared values depending on the ways in which the tool is used especially what kind of workpiece is processed; and
 - of the need to identify safety measures to protect the operator that are based on an estimation of exposure in the actual conditions of use (taking account of all parts of the operating cycle such as the times when the tool is switched off and when it is running idle in addition to the trigger time). Ⓒ

8.14.3 If information about the mass or weight of the tool is provided, it shall be the mass specified in 5.17.

Compliance is checked by inspection.

9 Protection against access to live parts

9.1 Tools shall be so constructed and enclosed that there is adequate protection against accidental contact with live parts. The requirement applies for all positions of the tool, even after removal of detachable parts and soft materials (elastomers), such as soft grip coverings.

Compliance is checked by inspection, and by the tests of 9.2 to 9.4, as applicable.

9.2 An **accessible part** is not considered to be live if:

- the part is supplied with **safety extra-low voltage**

or

- the part is separated from **live parts** by **protective impedance**.

In the case of **protective impedance**, the current between the part and the supply source shall not exceed 2 mA for d.c., and its peak value shall not exceed 0,7 mA for a.c., and moreover:

- for voltages having a peak value over 42,4 V up to and including 450 V, the capacitance shall not exceed 0,1 μF;
- for voltages having a peak value over 450 V up to and including 15 kV, the discharge shall not exceed 45 μC.

*Compliance is checked by operating the tool at **rated voltage**. Voltages and currents are measured between the relevant parts and each pole of the supply source. Discharges are measured immediately after the interruption of the supply.*

The quantity of electricity in the discharge is measured using a resistor having a nominal non-inductive resistance of 2 000 Ω . The quantity of electricity is calculated from the sum of all areas recorded on the voltage/time graph without taking voltage polarity into account.

NOTE Details of a suitable circuit for measuring the current are given in Figure C.3.

9.3 *Lamps located behind a detachable cover are not removed, provided the tool can be isolated from the supply by means of a plug or an **all-pole disconnection**. However, during insertion or removal of lamps which are located behind a detachable cover, protection against contact with **live parts** of the lamp cap shall be ensured.*

This excludes the use of screw type fuses and screw-type miniature circuit breakers which are accessible without the aid of a tool.

Test probe B of IEC 61032:1997 is applied with a force not exceeding 5 N, the tool being in every possible position except that tools normally used on the floor and having a mass exceeding 40 kg are not tilted. Through openings, the test probe is applied to any depth that the probe will permit, and it is rotated or angled before, during, and after insertion to any position.

If the opening does not allow the entry of the probe, a rigid test probe with the dimensions of the test probe B of IEC 61032:1997, but without any articulation, is used, the force on the probe is increased to 20 N and the test with the articulated test probe B of IEC 61032:1997 repeated.

*It shall not be possible to touch with the test probe **live parts** or **live parts** protected only by lacquer, enamel, ordinary paper, cotton, oxide film, beads or sealing compound.*

NOTE Lacquer, enamel, ordinary paper, cotton, oxide film on metal parts, beads and sealing compound, except self-hardening resins, are not considered to give the required protection against contact with **live parts**.

9.4 *Test probe 13 of IEC 61032:1997 is applied with a force not exceeding 5 N through openings in **class II tools** and **class II constructions**, except for those giving access to lamp caps and **live parts** in socket-outlets.*

The test probe is also applied through openings in earthed metal enclosures having a non-conductive coating such as enamel or lacquer.

*It shall not be possible to touch **live parts** with the test probe.*

9.5 **Class II tools** and **class II constructions** shall be so constructed and enclosed that there is adequate protection against accidental contact with **basic insulation**, and metal parts separated from **live parts** by **basic insulation** only.

Parts which are not separated from **live parts** by **double insulation** or **reinforced insulation** shall not be accessible.

This requirement applies for all positions of the tool, even after removal of **detachable parts**.

Compliance is checked by inspection and by applying the test probe B of IEC 61032:1997, as described in 9.3.

10 Starting

10.1 Tools shall start under all normal voltage conditions which may occur in use.

*Compliance is checked by starting the tool 10 times at no-load in succession at a voltage equal to 0,85 times the lowest **rated voltage** or 0,85 times the lower limit of the **rated voltage range**, **control devices** other than speed controls, if any, being set as in **normal use**.*

*Tools shall in addition be started 10 times in succession at a voltage equal to 1,1 times **rated voltage**.*

The interval between consecutive starts is made sufficiently long enough to prevent undue heating.

In all cases, the tool shall operate and overload protection devices incorporated in the tool shall not activate. Centrifugal and other automatic starting switches, if any, shall operate reliably, and without contact chattering.

10.2 Tools shall not draw excessive input current during starting that could lead to nuisance operation of facility mains over-current protection devices.

*Compliance is checked by starting the tool once at **rated voltage** and no-load with any speed controls set for maximum speed and all other **control devices** set as in **normal use**.*

*The current drawn by the tool at $(2,0 \pm 0,2)$ s after starting shall not exceed the greater of 30 A or 4 times the **rated current** of the tool.*

11 Input and current

The **rated input** or **rated current** shall be at least 110 % of the measured no-load input or current.

*Compliance is checked by measuring the power input or current of the tool when stabilized while all circuits which can operate simultaneously are in operation. The test shall be conducted without **accessories** attached or external load.*

*For tools marked with one or more **rated voltages**, the test is made at each of the **rated voltages**. For tools marked with one or more **rated voltage ranges**, the test is made at both the upper and lower limits of the ranges, unless the marking of the **rated input** is related to the mean value of the relevant voltage range, in which case the test is made at a voltage equal to the mean value of that range.*

12 Heating

12.1 Tools shall not attain excessive temperatures with **rated input** or **rated current**.

*Compliance is checked by determining the temperature rise of the various parts under the conditions specified in 12.2 to 12.5. Then the test of Clause C.3 at 1,06 times the **rated voltage** is made under heated conditions.*

12.2 *For tools with one or more **rated voltages**: The tool is operated at each **rated voltage**, under the load conditions specified in 12.2.1, the torque being applied is measured. While maintaining the previously measured torque, the voltage is then adjusted to 0,94 times the **rated voltage** and 1,06 times the **rated voltage**.*

The temperatures are measured at the most unfavourable of the two voltage settings. The temperatures that are measured by means of thermocouples are taken while the tool is operating.

For tools with a **rated voltage range**: The tool is operated

- at the lower limit of the **rated voltage range**, under the load conditions specified in 12.2.1, the torque being applied is measured. While maintaining the previously measured torque, the voltage is then adjusted to 0,94 times the lower limit of the **rated voltage range**;

and

- at the upper limit of the **rated voltage range**, under the load conditions specified in 12.2.1, the torque being applied is measured. While maintaining the previously measured torque, the voltage is then adjusted to 1,06 times the upper limit of the **rated voltage range**.

The temperatures are measured at the most unfavourable of the two voltage settings. The temperatures that are measured by means of thermocouples are taken while the tool is operating.

12.2.1 The load conditions for the heating test of 12.2 are as follows.

- For tools without an **inherent operating cycle**, the tool is operated with a torque load applied such that **rated input** or **rated current** is drawn until thermal equilibrium is reached.
- For tools with an **inherent operating cycle**, the tool is operated with a torque load applied such that **rated input** or **rated current** is drawn some time during each of the tool's operating cycles. The tool is cycled consecutively for 30 min.

12.3 This subclause provides specific test conditions for heating elements and cord storage devices.

12.3.1 Heating elements, if any, are operated under the conditions specified in Clause 11 of IEC 60335-1:2010, when the tool is operated at a voltage equal to 1,06 times the **rated voltage**.

12.3.2 For tools provided with an automatic cord reel, one third of the total length of the cord is unreeled. The temperature rise of the cord sheath is determined as near as possible to the hub of the reel and also between the two outermost layers of the cord on the reel.

For cord storage devices, other than automatic cord reels, which are intended to accommodate the **supply cord** partially while the tool is in operation, 50 cm of the cord is unwound. The temperature rise of the stored part of the cord is determined at the most unfavourable place.

12.4 Temperature rises, other than those of windings, are determined by means of fine-wire thermocouples so chosen and positioned that they have the minimum effect on the temperature of the part under test.

The temperature rise of electrical insulation, other than that of windings, is determined on the surface of insulation, at places where failure could cause a short circuit, contact between **live parts** and **accessible parts**, bridging of insulation, or reduction of **creepage distances** or **clearances** below the values specified in 28.1.

Temperature rises of windings are determined by the resistance method, unless the windings are non-uniform, or the method involves severe complications to make the necessary connections for the resistance measurement. In that case, the measurement is made by thermocouples.

*In determining the temperature rises of handles, knobs, grips and the like, consideration is given to all parts which are gripped in **normal use**, and, if of insulating material, to those parts in contact with hot metal.*

NOTE 1 If it is necessary to dismantle the tool to position thermocouples, a remeasurement of the **no-load input** is a method to check that the tool has been correctly reassembled.

NOTE 2 The point of separation of the cores of a multicore cord is an example of a place where thermocouples are positioned.

NOTE 3 Thermocouples having wires with a diameter not exceeding 0,3 mm are considered to be fine-wire thermocouples.

12.5 *During the test, **protective devices** shall not operate and sealing compound, if any, shall not flow out. The temperature rises shall not exceed the values shown in Tables 1a and 1b, except as allowed by 12.6.*

Table 1 – Maximum normal temperature rises (1 of 2)

Parts	Temperature rise K	
Windings ^a , if the insulation system is <ul style="list-style-type: none"> – class 105 – class 120 	75 90	(65) (80)
Windings ^a , if the insulation system according to IEC 60085:2007 is <ul style="list-style-type: none"> – class 130 – class 155 – class 180 – class 200 – class 220 – class 250 	95 115 140 160 180 210	(85)
Pins of appliance inlets: <ul style="list-style-type: none"> – for hot conditions – for cold conditions 	95 40	
Ambient of switches, temperature limiters ^b : <ul style="list-style-type: none"> – without <i>T</i>-marking – with <i>T</i>-marking 	30 <i>T</i> -25	
Rubber or polyvinyl chloride insulation of internal and external wiring, including supply cords : <ul style="list-style-type: none"> – without temperature rating ^c – with temperature rating (<i>T</i>) 	50 <i>T</i> -25	
Cord sheath used as supplementary insulation	35	
Rubber, other than synthetic, used for gaskets or other parts, the deterioration of which could affect safety: <ul style="list-style-type: none"> – when used as supplementary insulation or as reinforced insulation – in other cases 	40 50	
Lampholders E14 and B15: <ul style="list-style-type: none"> – metal or ceramic type – insulated type, other than ceramic – with <i>T</i>-marking 	130 90 <i>T</i> -25	
Material used as insulation other than that specified for wires and windings ^d <ul style="list-style-type: none"> – impregnated or varnished textile, paper or press board – laminates bonded with: <ul style="list-style-type: none"> • melamine-formaldehyde; phenol-formaldehyde or phenol-furfural resins • urea-formaldehyde resin – Printed circuit boards bonded with epoxy resin – moulding of: <ul style="list-style-type: none"> • phenol-formaldehyde with cellulose fillers • phenol-formaldehyde with mineral fillers • melamine-formaldehyde • urea-formaldehyde – polyester with glass-fibre reinforcement – silicone rubber – polytetrafluoroethylene – pure mica and tightly sintered ceramic material when such materials are used as supplementary insulation or reinforced insulation – thermoplastic material ^e 	70 85 65 120 85 100 75 65 110 145 265 400 –	(175) (150)

Table 1 (2 of 2)

Parts	Temperature rise K
Wood, in general ^f	65
Outer surface of capacitors ^g : <ul style="list-style-type: none"> – with marking of maximum operating temperature (<i>T</i>) – without marking of maximum operating temperature: <ul style="list-style-type: none"> • small ceramic capacitors for radio and television interference suppression • capacitors complying with IEC 60384-14 or 14.2 of IEC 60065:2011 • other capacitors ^g 	<i>T</i> -25 50 50 20
Parts in contact with oil having a flash-point of <i>t</i> °C	<i>t</i> -50
<p>^a To allow for the fact that the average temperature of windings of universal motors, relays, solenoids, etc., is usually above the temperature at the points on the windings where thermocouples are placed, the figures without parentheses apply when the resistance method is used, and those within parentheses apply when thermocouples are used. For windings of vibrator coils and a.c. motors, the figures without parentheses apply in both cases. For motors constructed so that the circulation of the air between the inside and the outside of the case is prevented, but not necessarily sufficiently enclosed to be called airtight, the temperature rise limits may be increased by 5 K.</p> <p>^b <i>T</i> signifies the maximum operating temperature.</p> <p>The ambient temperature of switches, thermostats and temperature limiters is the temperature of the air at the hottest point at a distance of 5 mm from the surface of the switch and component concerned.</p> <p>For the purpose of this test, switches and thermostats marked with individual ratings may be considered as having no marking for the maximum operating temperature, if requested by the tool manufacturer.</p> <p>^c This limit applies to cables, cords and wires complying with the relevant IEC standards; for others, it may be different. While no limit applies to connectors, it is recognized that these limits for wiring apply to internal wiring at the point where it is terminated in a connector.</p> <p>^d The values in parentheses apply, if the material is used for handles, knobs, grips and the like, and is in contact with hot metal.</p> <p>^e There is no specific limit for thermoplastic material, which has to withstand the tests of 13.1, for which purpose the temperature rise must be determined.</p> <p>^f The limit specified concerns the deterioration of wood, and it does not take into account deterioration of surface finishes.</p> <p>^g There is no limit for the temperature rise of capacitors which are short-circuited in 18.6.</p> <p>If other materials than those mentioned in the table are used, they are not to be subjected to temperatures in excess of their thermal capabilities as determined by ageing tests.</p> <p>The value of the temperature rise of a winding is calculated from the formula:</p> $\Delta t = \frac{R_2 - R_1}{R_1} (k + t_1) - (t_2 - t_1)$ <p>where</p> <p>Δt is the temperature rise;</p> <p>R_1 is the resistance at the beginning of the test;</p> <p>R_2 is the resistance at the end of the test;</p> <p>k is equal to 234,5 for copper windings, and 225 for aluminium windings;</p> <p>t_1 is the ambient temperature at the beginning of the test;</p> <p>t_2 is the ambient temperature at the end of the test.</p> <p>At the beginning of the test, the windings are to be at ambient temperature. It is recommended that the resistance of windings at the end of the test be determined by taking resistance measurements as soon as possible after switching off, and then at short intervals so that a curve of resistance against time can be plotted for ascertaining the resistance at the instant of switching off.</p>	

Table 2 – Maximum outside surface temperature rises

Parts	Temperature rise K
External enclosure, except handles held in normal use	60
Handles, knobs, grips, and the like which, in normal use , are continuously held:	
– of metal	30
– of porcelain or vitreous material	40
– of moulded material, rubber or wood	50
Handles, knobs, grips, and the like which, in normal use , are held for short periods only (e.g. switches):	
– of metal	35
– of porcelain or vitreous material	45
– of moulded material, rubber or wood	60

12.6 The following tests shall be conducted when the temperature rises of the armature and/or field windings exceed the values in Table 1 or when there is doubt with regards to the temperature classification of the insulation system.

Three samples of the armature and/or field are subjected to the following tests.

- a) *Windings are kept for 10 days (240 h) in a heating cabinet, the temperature of which is (80 ± 2) °C in excess of the temperature rise of the windings determined according to 12.4. Then the samples shall be gradually cooled to ambient temperature without introducing thermal shock.*
- b) *After this treatment, no interturn short circuit shall occur.*
- c) *The samples are then subjected to a humidity treatment as specified in 14.1.*
- d) *Immediately after this treatment, they shall withstand the tests of Annex D.*

NOTE The use of a growler is one method to detect interturn short circuits.

Faults which may occur in insulation, which did not show an excessive temperature rise during the test of 12.4, are ignored and are repaired, if necessary, in order to complete the tests of 12.6.

13 Resistance to heat and fire

13.1 The following parts shall be sufficiently resistant to distortion due to heat, if this could cause the tool to fail to comply with this standard:

- parts of thermoplastic material provided as an enclosure to comply with Clause 9;
- parts of thermoplastic material supporting current carrying parts;
- parts of thermoplastic material providing **supplementary insulation** or **reinforced insulation**.

For the purpose of 13.1, “supporting” means that the retention of the current carrying part by the insulating material is relied upon to fulfil 28.1. Contact alone does not constitute support.

This requirement does not apply to:

- insulation and sheath of flexible **supply cords** or internal wiring;
- cord guards;
- ceramic materials;
- insulating parts of motors: e.g. shaft insulation, end spiders, slot liners, wedges, commutators.

Compliance is checked by subjecting the relevant part of thermoplastic material to the ball pressure test of IEC 60695-10-2:2003. Any soft materials (elastomers), such as soft grip coverings, shall be removed.

The required thickness may be obtained by using two or more sections of the part.

The test is carried out at a temperature of (40 ± 2) °C plus the maximum temperature rise determined during the test of Clause 12, but it shall be at least

- *(75 ± 2) °C, for parts provided as an enclosure to comply with Clause 9 and for parts providing **supplementary insulation** or **reinforced insulation**;*
- *(125 ± 2) °C, for parts supporting current carrying parts.*

13.2 Parts of non-metallic material shall be adequately resistant to ignition and to spread of fire.

This requirement does not apply to

- internal parts that are more than 13,0 mm from an arcing part such as a commutator, unenclosed switch contacts, and the like;
- internal parts that are more than 1,0 mm from a non-arcing uninsulated **live part**, such as a bus bar, a connecting strap, a terminal, enamelled wire, and the like;
- internal parts that are 1,0 mm or less from connections or conductors carrying 0,2 A or less during **normal operation** or from a low power-circuit as described in Annex H;
- the insulation of wires;
- gears, cams, belts, bearings, fans, decorative trims, knobs which would contribute negligible fuel to fire;
- ceramic materials;
- insulating parts of motors: e.g. shaft insulation, end spiders, slot liners, wedges, commutators;
- small parts, the plastic content of which is less than 5 g;
- other external parts not likely to be ignited or to propagate flames originating from inside the tool.

Compliance is checked by one of the following:

- *subjecting parts of non-metallic material, or representative specimens no thicker than the relevant parts, to the glow-wire test of IEC 60695-2-11:2000, which is carried out at 550 °C;*
- *the material is classified at least HB according to IEC 60695-11-10:2013 provided that the test sample was no thicker than the relevant part;*
- *the material has a glow wire ignition temperature of at least 575 °C according to IEC 60695-2-13:2010 provided that the test sample was no thicker than the relevant part.*

Parts for which the above cannot be carried out, such as those made of soft or foamy material, shall meet the requirements specified in ISO 9772:2012 for category HBF material, the test sample being no thicker than the relevant part.

14 Moisture resistance

14.1 Tools shall be proof against humid conditions which may occur.

Compliance is checked by the following humidity test.

Cable entries, if any, are left open; if knock-outs are provided, one of them is opened.

Electrical components, covers, and other parts which can be removed without the aid of a tool are removed and subjected, if necessary, to the humidity test with the main part.

The humidity treatment is carried out in a humidity cabinet containing air with a relative humidity of $(93 \pm 3) \%$, obtained e.g. by placing in the humidity cabinet a saturated solution of Na_2SO_4 or KNO_3 in water, having a sufficiently large contact surface with the air. The temperature of the air, at all places where samples can be located, is maintained within 2 K of any convenient value t between 20 °C and 30 °C. In order to achieve the specified conditions within the cabinet, it is necessary to ensure constant circulation of the air within and, in general, to use a cabinet which is thermally insulated.

Before being placed in the humidity cabinet, the sample is brought to a temperature between t and $(t + 4)$ °C. The tool is considered to be brought to the specified temperature by keeping it at this temperature for at least 4 h before the humidity treatment.

The tool is kept in the cabinet for 48 h.

*Immediately after this test, the tool shall withstand the tests of Clause C.2 at **rated voltage**. Then the tool shall withstand the test of Annex D in the humidity cabinet, or in the room in which the tool was brought to the prescribed temperature after reassembly of those parts which may have been removed.*

*In addition a test of Clause D.2 is applied between accessible metal parts and the **supply cord** which is wrapped with metal foil where it is located in an inlet bushing, a cord guard or a cord anchorage, any clamping screws being tightened to the torque specified in Table 11. The test voltage is 1 250 V for **class I tools** and 1 750 V for **class II tools**.*

14.2 The enclosure of the tool shall provide the degree of protection against moisture in accordance with the classification of the tool.

Compliance is checked by the appropriate treatment specified in 14.2.2, with the tool conditions as in 14.2.1.

14.2.1 *The tool is not connected to the supply.*

Tools are turned continuously at approximately 1 rev/min through the most unfavourable positions during the test.

Electrical components, covers and other parts which can be removed without the aid of a tool are removed and subjected, if necessary, to the relevant treatment with the main part.

14.2.2 *Tools other than IPX0 are subjected to tests of IEC 60529:2013 as follows:*

- IPX1 tools are subjected to the test described in 14.2.1;*
- IPX2 tools are subjected to the test described in 14.2.2;*
- IPX3 tools are subjected to the test described in 14.2.3a;*
- IPX4 tools are subjected to the test described in 14.2.4a;*
- IPX5 tools are subjected to the test described in 14.2.5;*
- IPX6 tools are subjected to the test described in 14.2.6;*
- IPX7 tools are subjected to the test described in 14.2.7.*

For this last test, the tool is immersed in water containing approximately 1,0 % NaCl.

Immediately after the appropriate treatment, the tool shall withstand the electric strength test of Annex D, and inspection shall show that there is no trace of water on insulation which could

result in a reduction of **creepage distances** and **clearances** below the values specified in 28.1.

14.3 Liquid systems or spillage of liquid shall not subject the user to an increased risk of electrical shock.

Compliance is checked by the following test:

*The **residual current device**, if any, shall be disabled during the test. Electrical components, covers and other parts which can be removed without the aid of a tool are removed, except those fulfilling the test of 21.22.*

The tool is prepared with approximately 1,0 % NaCl solution in the following modes if applicable:

- *as described in 8.14.2;*
- *the liquid container of the tool is completely filled, and a further quantity, equal to 15 % of the capacity of the container, or 0,25 l, whichever is the greater, is poured in steadily over a period of 60^{+0}_{-10} s, while the tool is resting in its filling position according to 8.14.2 d);*
- *a detachable liquid container is filled completely and mounted and dismantled 10 times on the tool.*

*In each applicable preparation, the tool is operated at **rated voltage** in each position consistent with the relevant part of IEC 62841-2, IEC 62841-3 or IEC 62841-4 and the instructions according to 8.14.2 b) for 1 min while monitoring the leakage current as in Clause C.3. During the test the leakage current shall not exceed:*

- *2 mA for a **class II tool**;*
- *5 mA for a **class I tool**.*

*Following this test, the tool shall meet the electric strength test of D.2 between **live parts** and **accessible parts** after being allowed to dry for 24 h at ambient temperature.*

14.4 Liquid systems shall not subject the user to an increased risk of electrical shock by components not capable of withstanding the pressure during operation.

Compliance is checked by the following test.

*The **residual current device**, if any, shall be disabled during the test.*

*The **liquid system** is closed and an approximately 1,0 % NaCl solution at a hydrostatic pressure equal to twice the pressure stated in 8.14.2 d) 1) is applied for 1 h.*

The tool is then placed for 1 min, in all positions consistent with the relevant part of IEC 62841-2, IEC 62841-3 or IEC 62841-4 and the instructions according to 8.14.2 b) while monitoring the leakage current as in Clause C.2. During the test the leakage current shall not exceed:

- *2 mA for a **class II tool**;*
- *5 mA for a **class I tool**.*

*Following this test, the tool shall meet the electric strength test of Clause D.2 between **live parts** and **accessible parts** after being allowed to dry for 24 h at ambient temperature.*

14.5 Residual current devices used to provide protection from shock in the case of failure of the **liquid system** shall comply with IEC 61540:1999 and shall meet the following requirements a) to c):

- a) The **RCD** shall disconnect both mains conductors, but not the earth conductor if provided, when the leakage exceeds 10 mA and with a maximum response of 300 ms.

Compliance is checked by inspection and the test of 9.9.2 of IEC 61540:1999. In addition, during the test, the earthing conductor shall not become disconnected.

- b) The **RCD** shall be reliable for its intended use.

*Compliance is checked at **rated voltage** by operating the **residual current device** under conditions of simulated leakage as in a) above during conditions of locked rotor of the tool for 50 cycles. The **residual current device** shall operate correctly for all cycles.*

- c) The **RCD** shall be installed such that it is unlikely to be removed during use or normal maintenance.

*This requirement is considered fulfilled if the **residual current device** is fixed to the tool or the power **supply cord** connected to the tool.*

*Where fitted in the **supply cord** the **residual current device** shall be provided with **Type Y attachment** or **Type Z attachment** for connection with the **supply cord** and **interconnection cord**.*

Compliance is checked by inspection.

15 Resistance to rusting

15.1 Ferrous parts used to conduct electricity and those mechanical parts specified in the relevant part of IEC 62841-2, IEC 62841-3 or IEC 62841-4 shall be adequately protected against rusting.

Compliance is checked by the following test.

All grease is removed from the parts to be tested by immersing them in a suitable degreasing agent for 10 min.

The parts are then immersed for 10 min in a 10 % solution of ammonium chloride in water at a temperature of (20 ± 5) °C.

Without drying, but after shaking off any drops, the parts are placed for 10 min in a box containing air saturated with moisture at a temperature of (20 ± 5) °C.

When using the liquids specified for the test, adequate precautions must be taken to prevent the inhalation of their vapours.

After the parts have been dried for 10 min in a heating cabinet at a temperature of (100 ± 5) °C, their surfaces shall show no signs of rust when viewed with normal vision from a distance of (500 ± 50) mm.

Traces of rust on sharp edges and any yellowish film removable by rubbing are ignored.

For small helical springs and the like, and for parts exposed to abrasion, a layer of grease may provide sufficient protection against rusting. Such parts are only subjected to the test if there is doubt about the effectiveness of the grease film, and the test is then made without previous removal of the grease.

16 Overload protection of transformers and associated circuits

Tools incorporating circuits supplied from a transformer shall be so constructed that, in the event of short circuits which are likely to occur, excessive temperatures do not occur in the transformer, or in the circuits associated to the transformer.

Examples of short-circuits which are likely to occur are the short-circuiting of bare or inadequately insulated conductors of **safety extra-low voltage** circuits which are accessible, and the internal short-circuiting of lamp filaments.

A failure of insulation complying with the requirements specified for **basic insulation** of class I or **class II construction** is not, for the purpose of this requirement, considered as likely to occur.

*Compliance is checked by applying the most unfavourable short circuit or overload which is likely to occur in **normal use**, the tool being operated as follows:*

- *for tools with **rated voltage(s)**, the tool is operated at a voltage equal to 1,06 times or 0,94 times **rated voltage**, whichever is the more unfavourable;*
- *for tools with a **rated voltage range**, the tool is operated at a voltage equal to 1,06 times the upper limit of the **rated voltage range** or at a voltage equal to 0,94 times the lower limit of the **rated voltage range**, whichever is the more unfavourable.*

*The temperature rise of the insulation of the conductors of **safety extra-low voltage** circuits is determined, and shall not exceed the relevant value specified in Table 1 by more than 15 K.*

The winding temperature of transformers shall not exceed the value specified for windings in Table 3, except for transformers which comply with IEC 61558-1.

NOTE Protection of transformer windings can be, for example, obtained by the inherent impedance of the winding, or by means of fuses, automatic switches, **thermal cut-outs** or similar devices incorporated in the transformer, or similar devices located inside the tool only accessible with the aid of a tool.

17 Endurance

17.1 Tools shall be so constructed that there will be no electrical or mechanical failure that might impair compliance with this standard. The insulation shall not be damaged and contacts and connections shall not work loose as a result of heating, vibrations, etc.

Moreover, overload protection devices incorporated in the tool shall not activate under normal running conditions.

Compliance is checked by the test of 17.2 and, for tools provided with a centrifugal or other starting switch, also by the test of 17.3.

*Immediately after these tests, the tool shall withstand an electric strength test as specified in Annex D, the test voltages being, however, reduced to 75 % of the specified values. Connections shall not have worked loose, and there shall be no deterioration impairing safety in **normal use**.*

17.2 **Hand-held tools and transportable tools** are operated intermittently at no-load.

NOTE 1 Requirements for **lawn and garden machinery** are specified in the relevant part of IEC 62841-4.

Each cycle of operation comprises an "on" period of 100 s and an "off" period of 20 s, the "off" periods being included in the specified operating time. If the cycle of operation limited by the construction and/or marking is less than 100 s "on" and 20 s "off", then this cycle may be used.

The tool may be switched on and off by means of a switch other than that incorporated in the tool unless this disables a functionality of the tool switch.

Hand-held tools are operated for 24 h at a voltage equal to 1,1 times the highest **rated voltage** or 1,1 times the upper limit of the **rated voltage range**, and then for 24 h at a supply voltage equal to 0,9 times the lowest **rated voltage** or 0,9 times the lower limit of the **rated voltage range**. The 24 h of operation need not be continuous. During the test, the tool is placed in three different positions, the operating time, at each test voltage, being approximately 8 h for each position.

NOTE 2 The change of position is made to prevent abnormal accumulation of carbon dust in any particular place. Examples of the three positions are horizontal, vertically up and vertically down.

Transportable tools are operated for 12 h at a voltage equal to 1,1 times the highest **rated voltage** or 1,1 times the upper limit of the **rated voltage range**, and then for 12 h at a supply voltage equal to 0,9 times the lowest **rated voltage** or 0,9 times the lower limit of the **rated voltage range**. The 12 h of operation need not be continuous. During the test, the tool is placed in its normal operating position according to 8.14.2.

*During this test, replacement of the carbon brushes is allowed, and the tool is oiled and greased as in **normal use**. If mechanical failure occurs and does not impair compliance with this standard, the part that failed may be replaced.*

If the temperature rise of any part of the tool exceeds the temperature rise determined during the test of 12.1, forced cooling or rest periods may be applied, the rest periods being excluded from the specified operating time. If forced cooling is applied, it shall not alter the air flow of the tool or redistribute carbon deposits.

During these tests, overload protection devices incorporated in the tool shall not activate.

17.3 Tools provided with a centrifugal or other automatic starting switch are started 10 000 times at **rated input** or **rated current**, and at a voltage equal to 0,9 times the lowest **rated voltage** or 0,9 times the lower limit of the **rated voltage range**, the operating cycle being that specified in 17.2.

18 Abnormal operation

18.1 Tools shall be so designed that the risk of fire and mechanical damage impairing safety and the protection against electric shock as a result of abnormal operation is obviated as far as is practicable.

Compliance is checked by the tests of 18.3 to 18.4 under the conditions specified in 18.2 applying the acceptance criteria of 18.1.1.

18.1.1 *During the tests, the tool shall not emit flames or molten metal, checked by inspection.*

*After the tests, and when the tool has returned to within 5 K of the ambient temperature, compliance with Clause 9 shall be maintained and the tool shall withstand the electric strength test of Annex D between **live parts** and **accessible parts**.*

If the tool can still operate at the conclusion of the test, it shall continue to comply with 19.1 but without repeating the tests of Clause 20.

18.2 Fuses, **non-self-resetting-thermal cut-outs**, overcurrent protection devices or the like, incorporated into the tool, may be used to provide the necessary protection. **Electronic circuits** that are relied upon for protection shall be evaluated for this **safety critical function** as in 18.8.

Unless otherwise specified, the tests are continued until a **protective device** operates, or until steady conditions are established or an open circuit occurs. If it is an intentionally weak part that is permanently open-circuited to terminate the test, the relevant test is repeated on a second sample. This second test shall be terminated in the same way, unless the test is otherwise satisfactorily completed.

An intentionally weak part is a part intended to fail under conditions of abnormal operation so as to prevent the occurrence of a condition which could impair compliance with this standard. Such a part may be a replaceable component, such as a resistor, a capacitor, or a **thermal link**, or a part of a component to be replaced, such as an inaccessible and non-resettable **thermal cut-out** incorporated in a motor.

18.3 Tools incorporating a series motor are operated without **accessories** at a voltage equal to 1,3 times **rated voltage** for 1 min at no-load.

During the test, parts shall not be ejected from the tool. After this test, the tool need not be capable of further use.

An additional device incorporated in the tool to limit the speed may operate during the test.

18.4 Tools incorporating multiphase induction motors are operated, starting from cold,

- for 30 s, if they are kept switched on by hand or continuously loaded by hand;
- or otherwise, for 5 min;

with one phase disconnected, and under the torque produced while operated at **rated voltage** or the mean value of the **rated voltage range** with **rated input** or **rated current**.

At the end of the test period specified, or at the instant of operation of fuses, **thermal cut-outs**, motor protection devices, and the like, the temperature of the windings shall not exceed the values shown in Table 3.

Table 3 – Maximum winding temperature

Class	105	120	130	155	180	200	220	250
Temperature °C	200	215	225	240	260	280	300	330

18.5 Protection against electric shock shall not be impaired when a **class II tool** or a **class I tool** employing **class II construction** (see 5.10) is subjected to running overload conditions.

For tools other than **lawn and garden machinery** covered by a relevant part of IEC 62841-4 with

- series motors, compliance is checked by the test of 18.5.1. In the case of a **class I tool** with a series motor employing a class II armature construction, the test of 18.5.1 is replaced by the test of 18.5.2;
- motors having electronically commutated stator windings, compliance is checked by the test of 18.5.4;
- other motors, compliance is checked by the test of 18.5.3.

For **lawn and garden machinery**, the required test is specified in the relevant part of IEC 62841-4.

18.5.1 All fuses, **thermal cut-outs**, overload protectors and the like specified in 18.2 that are accessible or can be reset by the user without the aid of a tool and any self-resetting **protective devices** are shorted.

The function of **electronic circuits** that prevent the tool from operating at 160 % of the **rated current** shall be disabled unless that function has been evaluated as a **safety critical function** in accordance with 18.8. The tool is connected to a minimum 12 kVA circuit.

The leakage current between **live parts** and **accessible parts**, that are not grounded by class I construction, is measured in accordance with Clause C.3 and is monitored throughout the test and after the test until the leakage current has stabilized or decreases. The leakage current shall not exceed 2 mA.

The tool is operated at **rated voltage**. The tool is loaded to 160 % of the **rated current**. The mechanical load is maintained for either 15 min or until the tool open-circuits or flame appears. If the tool will not operate at 160 %, the tool is stalled for 15 min or until the tool open-circuits or flame appears. If either condition occurs, immediately switch off the current and, if flames appear, extinguish with CO₂ extinguisher.

After the tool has returned to within 5 K of the ambient temperature, an electric strength test per Clause D.2 is performed between **live parts** and those **accessible parts** that are not grounded by class I construction as follows:

- if a tool does not operate after the 15 min, apply a 1 500 V electric strength test;
- if a tool still operates after the 15 min, apply a 2 500 V electric strength test.

If the tool has permanently open-circuited due to an over temperature condition before 15 min has elapsed for any reason except the opening of a motor winding, the test shall be repeated. This second test shall be terminated in the same mode unless the test is otherwise satisfactorily completed.

If the test terminated due to a non-self-resetting thermal limit function of an **electronic circuit**, this circuit shall either be bypassed or evaluated as a **safety critical function** in 18.8.

If the tool has permanently open-circuited for reasons other than above, the cause is determined and bypassed in a new sample and the test is repeated.

18.5.2 A sample of the armature is connected to a minimum 12 kVA circuit.

The leakage current between the commutator segments and the armature shaft, is measured with 1,06 times the tool's **rated voltage** applied between the commutator segments, located 180° apart, and the armature shaft (see Figure 3). The leakage current is monitored throughout the test and after the test until it has stabilized or decreases. The leakage current shall not exceed 2 mA.

The armature is subjected to carry 160 % of the **rated current**. The current is applied to the commutator segments that are located 180° apart. The current, without further adjustment, is applied for either 15 min or until the armature open-circuits or flame appears. If either condition occurs, immediately open S1 of Figure 3 and, if flames appear, extinguish with CO₂ extinguisher.

After the armature has returned to within 5 K of the ambient temperature, a 1 500 V electric strength test per Clause D.2 is performed between the commutator segments and the armature shaft.

18.5.3 *The tool is connected to a minimum 12 kVA circuit and is operated under stalled conditions and under the conditions in 18.2 by*

- *locking the rotor of tools for which the locked rotor torque is smaller than the full load torque;*
- *locking moving parts of other tools.*

If a tool has more than one motor, the test is carried out for each motor separately.

Tools incorporating motors and having capacitors in the circuit of an auxiliary winding are operated with the rotor locked, the capacitors being open-circuited one at a time. The test is repeated with the capacitors short-circuited one at a time unless they are of class P2 of IEC 60252-1.

*Other tools are supplied at **rated voltage** for a period*

- *of 30 s for*
 - **hand-held tools,**
 - *tools that have to be kept switched on by hand or foot, and*
 - *tools that are continuously loaded by hand;*
- *of 5 min for other tools that are operated while attended. Tools that are tested for 5 min are indicated in the relevant part of IEC 62841-3 or IEC 62841-4.*

During the test, the temperature of the windings shall not exceed the relevant value specified in Table 3 and the acceptance criteria of 18.1.1 shall be applied.

18.5.4 *Motors with electronically commutated stator windings are evaluated under conditions that represent all possible static faults of the outputs of the motor drive circuitry unless such circuitry has a protective function to prevent these faults which has been evaluated as an **SCF** in accordance with 18.8 with a minimum $PL = a$.*

NOTE For example, all possible static faults in a delta configured brushless motor with phases A, B and C energized by a three-phase motor drive circuit would be tested by two cases:

1. applying the motor drive circuitry supply voltage between phases A and B shorted together and phase C; and
2. applying the motor drive circuitry supply voltage between phase A and phase B with phase C open.

A new sample is used for each representative fault.

*All fuses, **thermal cut-outs**, overload protectors and the like specified in 18.2 that are accessible or can be reset by the user without the aid of a tool and any self-resetting **protective devices** are shorted.*

*The leakage current between **live parts** and **accessible parts**, that are not grounded by class I construction, is measured in accordance with Clause C.3 and is monitored throughout the test and after the test until the leakage current has stabilized or decreases. The leakage current shall not exceed 2 mA.*

The windings are energized by applying the voltage of the source for the motor drive circuitry for either 15 min or until the winding open-circuits or flame appears. If either condition occurs, immediately switch off the current and, if flames appear, extinguish with CO₂ extinguisher.

*After the tool has returned to within 5 K of the ambient temperature, an electric strength test per Clause D.2 is performed between **live parts** and those **accessible parts** that are not grounded by class I construction as follows:*

- *if any winding is open circuited, apply a 1 500 V electric strength test;*
- *if no windings are open circuited, apply a 2 500 V electric strength test.*

18.6 Electronic circuits shall be so designed and applied so that a fault condition will not render the tool unsafe with regard to electric shock, fire hazard or accessibility to moving parts.

Compliance is checked by evaluation of the fault conditions specified in 18.6.1 for all circuits or parts of circuits.

*The tool containing the circuit is to be placed on a soft wood surface covered by two layers of tissue paper; the sample is to be covered by one layer of untreated 100 % cotton medical gauze. The tool is operated at **rated voltage**. A new sample can be used for each fault listed in 18.6.1.*

No charring or burning of the gauze or tissue paper shall result. Charring is defined as a blackening of the gauze caused by combustion. Discolouration of the gauze caused by smoke is acceptable. Charring or igniting of the tissue paper or gauze from the means that is used to create the short is not regarded as a failure.

Protection against electric shock as specified in Clause 9 shall be maintained.

Protection against accessibility to moving parts as specified in 19.1 shall be maintained, if the test resulted in new openings being created in the enclosure.

*If a circuit fulfils the requirements of a low power circuit as described in Annex H and there is no risk of electric shock or the loss of a **safety critical function** as defined in 18.8, then this evaluation is not performed.*

*If the circuit is encapsulated with an insulating material with a minimum thickness of 0,5 mm and there is no risk of loss of a **safety critical function**, then the circuit may be evaluated by open-circuiting of any connection and short-circuiting of any two connections to the encapsulated circuit. Encapsulation is not necessary to fully cover electrolytic capacitors.*

NOTE 1 In general, encapsulation effectively limits the likelihood of the spread of fire within the encapsulated circuit. Electrolytic capacitors often require an unobstructed surface to allow venting under fault conditions.

*Any fuse, **thermal cut-outs, thermal links, temperature limiters**, electronic devices or any component(s) or conductor(s) that interrupt the current may operate during the above tests, provided at least any of the following is fulfilled:*

- *the test is repeated and passed two more times, using two additional samples; or*
- *the tool withstands the test of 18.6.1 with the fuse, **thermal cut-out** or **thermal link** bridged; or*
- *if a miniature fuse link complying with IEC 60127 operates, the tool withstands the test of 18.6.2.*

If a conductor of a printed circuit board becomes open-circuited, the tool is considered to have withstood the particular test, provided all of the following conditions are met:

- *any loosened conductor does not reduce the **creepage distances** or **clearances** between **live parts** and accessible conductive parts below the values specified in Clause 28;*
- *the tool withstands the test when repeated with the open-circuited conductor bridged or, alternatively, the test may be repeated two more times, using two additional samples, providing each test opens the conductor at the same point.*

NOTE 2 Examination of the tool and its circuit diagram will reveal the fault conditions which have to be simulated through circuit analysis, so that testing can be limited to those cases which may be expected to give the most unfavourable result.

18.6.1 *The following fault conditions are considered and, if necessary, applied one at a time, consequential faults being taken into consideration:*

- a) *short-circuit of **creepage distances** and **clearances** between conductive parts of different polarity, if these distances are less than the values specified in Clause 28, unless the relevant part is encapsulated;*
- b) *open-circuit at the terminal of any component;*
- c) *short-circuit of capacitors, unless they comply with IEC 60384-14;*
- d) *short-circuit of any two terminals of an **electronic component**, other than a monolithic integrated circuit. This fault is not applied between the two circuits of an optocoupler;*
- e) *failure of triacs in the diode mode;*
- f) *failure of a monolithic integrated circuit or other circuits that cannot be assessed by the fault conditions a) to e). In this case the possible hazardous situations of the tool are assessed to ensure that safety does not rely on the correct functioning of such a component. All possible output signals are considered under fault conditions within the integrated circuit. If it can be shown that a particular output signal is unlikely to occur, then the relevant fault is not considered.*

Components such as thyristors and triacs are not subjected to fault condition f).

Positive temperature coefficient resistors (PTC's) are not short-circuited if they are used within their manufacturer's declared specification.

For simulation of the conditions, the tool is operated at no-load adjusted to maximum output speed.

The test is conducted until failure or until one of the following occurs:

- *for mains-operated tools, the tool no longer draws supply current; or*
- *steady conditions are established; or*
- *the test samples return to within 5 K of the ambient temperature; or*
- *a test period of 3 h has elapsed.*

18.6.2 *If the safety of the tool depends upon the operation of a miniature fuse-link complying with IEC 60127 during any of the fault conditions specified in 18.6.1, the test results of 18.6.1 are acceptable, provided the test is repeated but with the miniature fuse-link replaced by an ammeter. If the current measured*

- *does not exceed 2,1 times the rated current of the fuse-link, the circuit is not considered to be adequately protected and the test is carried out with the fuse-link short-circuited;*
- *is at least 2,75 times the rated current of the fuse-link, the circuits is considered to be adequately protected;*
- *is between 2,1 times and 2,75 times the rated current of the fuse-link, the fuse-link is short-circuited and the test is carried out*
 - *for the relevant period or for 30 min, whichever is the shorter, for quick acting fuse-links;*
 - *for the relevant period or for 2 min, whichever is the shorter, for time lag fuse-links.*

In case of doubt, the maximum resistance of the fuse-link has to be taken into account when determining the current.

NOTE The verification whether the fuse-link acts as a protecting device is based on the fusing characteristics specified in IEC 60127-3, which also gives the information necessary to calculate the maximum resistance of the fuse-link.

18.7 Switches or other devices for motor reversal shall withstand the stresses occurring when the sense of rotation is reversed under running conditions where such a reversal is possible.

Compliance is checked by the following test.

*The tool is operated at a voltage equal to **rated voltage** at no-load; the device for reversing the sense of rotation being in such a position that the rotor rotates in one direction at full speed.*

The direction of the rotation is then reversed, without the device resting in an intermediate "off" position.

This operation sequence is performed 25 times.

After the test, the switch shall have no electrical or mechanical failure. If the switch operates properly in the "on" and "off" positions at the end of the test, it is considered to have no mechanical or electrical failure.

18.8 Electronic circuits providing safety critical functions

18.8.1 General

Electronic circuits that provide **safety critical functions** shall be

- reliable
- and
- not susceptible to loss of **safety critical function** due to exposure to electromagnetic environmental stresses encountered in anticipated environments.

*Compliance is checked by exposing these **electronic circuits** to the immunity tests described in*

- 18.8.2 to 18.8.6 for **electronic circuits** with no internal clock frequency or oscillator frequency higher than 15 MHz;
- 18.8.2 to 18.8.7 for all other **electronic circuits**;

*which shall be passed without a loss of the **safety critical function**. The tests are carried out with the tool supplied at **rated voltage** or the mean value of the **rated voltage range**, unless the difference between the upper and lower limit of the **rated voltage range** is greater than 20 % of the mean value of the range, in which case the test is conducted at both the upper and lower limits of the **rated voltage range**.*

*In addition, these **electronic circuits** shall be evaluated using the fault conditions of 18.6.1 but shall not result in a loss of any **safety critical function** or shall place and maintain the tool into a safe state while the fault condition is present. If the concept of 18.6.1 is not appropriate due to the design of the **electronic circuit** (e.g. in the case of a single channel design), then its reliability shall be evaluated by the methods of ISO 13849-1. Required performance levels for applicable **safety critical functions** are specified by the relevant part of IEC 62841-2, IEC 62841-3 or IEC 62841-4. Typical **safety critical functions** are indicated in Table 4.*

NOTE 1 An example for a safe state is a tool that is inoperable.

Table 4 – Required performance levels

Type and purpose of SCF	Minimum Performance Level (PL)
Power switch – prevent unwanted switch-on	*
Power switch – provide desired switch-off	*
For tools where marking with the direction of rotation is required by the relevant part of IEC 62841-2, IEC 62841-3 or IEC 62841-4: Provide desired direction of rotation	*
Any electronic control to pass the test of 18.3	*
For tools covered by 19.6: Overspeed prevention to prevent output speed above 130 % of rated (no-load) speed	*
For tools other than those covered by 19.6 or with output speed increases that do not exceed 130 % of rated (no-load) speed: Any speed limiting device	Not a SCF
Restart prevention, if required by the relevant part of IEC 62841-2, IEC 62841-3 or IEC 62841-4	*
Soft start, if required by the relevant part of IEC 62841-2, IEC 62841-3 or IEC 62841-4	*
Prevent exceeding thermal limits as in Clause 18	*
Prevent self-resetting as required in 23.3	*
Ⓒ * Performance levels are to be specified in the relevant part of EN 62841-2, EN 62841-3 or EN 62841-4. Ⓒ	

If only $MTTF_d$ is applied to achieve the required PL, the required minimum $MTTF_d$ for each PL level shall be as follows:

- PL = a: $MTTF_d = 5$ years;
- PL = b: $MTTF_d = 20$ years;
- PL = c: $MTTF_d = 50$ years.

Ⓒ Text deleted Ⓒ

Software used in portions of the circuit comprised of a microcontroller or in other programmable devices shall comply with the requirements for software class B in accordance with Subclause H.11.12.3 of IEC 60730-1:2010, if the failure of these circuits would create a loss of the **safety critical function**. In the case where software class B is realized by single channel with periodic self-test, an acceptable period is regarded as either after each activation of the **power switch** or a maximum of 5 min.

H.11.12.3.4.1 is only applicable for **SCF** with a PL = c or higher.

NOTE 5 The allowance to use microcontrollers and other programmable logic, which are considered as “complex electronic circuits”, for category 1 in accordance with ISO 13849-1, is based upon their fulfilment of the requirements of H.11.12.3 of IEC 60730-1:2010.

Any design that only alerts the user of the loss of the **SCF** is not considered sufficient to fulfil the required PL.

18.8.2 The tool is subjected to electrostatic discharges in accordance with IEC 61000-4-2:2008, test level 4 being applicable for air discharge and test level 3 being applicable for contact discharge. Ten discharges having a positive polarity and ten discharges having a negative polarity are applied.

18.8.3 *The tool is subjected to fast transient bursts in accordance with IEC 61000-4-4:2012, test level 3 being applicable. The bursts are applied with a repetition frequency of 5 kHz for 2 min with a positive polarity and for 2 min with a negative polarity.*

18.8.4 *The power supply terminals of the tool are subjected to voltage surges in accordance with IEC 61000-4-5:2005, five positive impulses and five negative impulses being applied at the selected points. Test level 3 is applicable for the line-to-line coupling mode, a generator having a source impedance of 2 Ω being used. Test level 4 is applicable for the line-to-earth coupling mode, a generator having a source impedance of 12 Ω being used.*

For tools having surge arresters incorporating spark gaps, the test is repeated at a level that is 95 % of the flashover voltage.

18.8.5 *The tool is subjected to injected currents in accordance with IEC 61000-4-6:2008, test level 3 being applicable. During the test, all frequencies between 0,15 MHz to 230 MHz are covered.*

18.8.6 *The tool is subjected to the Class 3 voltage dips and interruptions in accordance with IEC 61000-4-11:2004. The values specified in Table 1 and Table 2 of IEC 61000-4-11:2004 are applied at zero crossing of the supply voltage.*

18.8.7 *The tool is subjected to radiated fields in accordance with IEC 61000-4-3:2010, test level 3 being applicable. The frequency ranges tested shall be 80 MHz to 1 000 MHz.*

NOTE The dwell time for each frequency is to be sufficient to observe a possible malfunction of the circuit providing a **safety critical function**.

19 Mechanical hazards

19.1 Moving and other dangerous parts of the tool shall, as far as is compatible with the use and working of the tool, be so positioned or enclosed to provide adequate protection against personal injury.

Protective enclosures, covers, **guards** and the like shall have adequate mechanical strength for their intended purpose. They shall not be removable without the aid of a tool.

When used as protection of the working element, an **adjustable guard** shall have an easily accessible means of accurate adjustment with the objective of minimizing access to the dangerous parts.

The use and adjustment of a **guard** shall not create other dangers, for example by reducing or obstructing the operator's view, by transferring heat, or causing other reasonably foreseeable hazards.

Compliance is checked by inspection, by the tests of Clause 20 and by means of the test probe B of IEC 61032:1997 with a force not exceeding 5 N. Prior to the application of the test probe any soft materials (elastomers), such as soft grip coverings, shall be removed. It shall not be possible to touch dangerous moving parts with this test probe. This test is not applicable for dust collection openings with the dust collection devices removed, as they are tested in accordance with 19.3.

19.2 Tools shall have no ragged or sharp edges, other than those necessary for the functioning of the tool, which could create a hazard for the user.

Compliance is checked by inspection.

19.3 It shall not be possible to reach dangerous moving parts through dust collection openings with the **detachable parts** or provisions for dust collection removed, if any.

Compliance is checked by applying a rigid test probe with the dimensions of the test probe B of IEC 61032:1997, but without any articulation, with a force not exceeding 5 N.

19.4 Hand-held tools shall have at least one handle or grasping surface to ensure safe handling during use.

Transportable tools shall be provided with at least one handle, grasping surface or the like to ensure safe transportation.

Lawn and garden machinery shall have adequate grasping surfaces to ensure safe handling during use.

Compliance is checked by inspection.

19.5 Tools shall be designed and constructed to allow, where necessary, a visual check of the contact of the cutting tool with the workpiece.

Compliance is checked by inspection.

19.6 For all tools where the relevant part of IEC 62841-2, IEC 62841-3 or IEC 62841-4 requires the tool to be marked with the **rated no-load speed**, the no-load speed of the spindle at **rated voltage** shall not exceed 110 % of the **rated no-load speed**.

*Compliance is checked by measuring the speed of the spindle after the tool has been operating for 5 min at no-load. During the test, separable **accessories** are not mounted.*

19.7 Transportable tools and **lawn and garden machinery** intended to be used on a surface such as the floor or a table shall have adequate stability.

Compliance is checked by the following test, tools provided with an appliance inlet being fitted with an appropriate connector and flexible cable or cord.

The tool is placed with the motor switched off in any normal position of use on a plane inclined at an angle of 10° to the horizontal, the cable or cord resting on the inclined plane in the most unfavourable position. If, however, the tool is such that, were it to be tilted through an angle of 10° when standing on a horizontal plane, a part of it not normally in contact with the supporting surface would touch the horizontal plane, the tool is placed on a horizontal support and tilted in the most unfavourable direction through an angle of 10°. For the test, the tool is prevented from sliding.

Tools provided with doors are tested with the doors open or closed, whichever is the more unfavourable.

*Tools intended to be filled with liquid by the user in **normal use** are tested empty or filled with the most unfavourable quantity of water or the recommended liquid, up to the rated capacity.*

The tool shall not tip over.

19.8 Transportable tools provided with wheels identified in the relevant part of IEC 62841-3 shall have adequate stability during transportation.

Compliance is checked by the following test.

The tool is held in its normal transportation position while traversing in both directions perpendicular to the slope of a plane inclined at an angle of 10° to the horizontal, the cable or the cord wrapped up and stored. The tool shall not tip over.

19.9 If, in accordance with 8.14.2, the user is instructed to remove a **fixed guard**, such as for maintenance, to convert the tool or to change the **accessory**, then the fastenings shall remain attached to the **guard** or to the machinery. If a fastening need not be completely removed for removing the **guard**, it shall be considered as still attached.

Compliance is checked by inspection and manual test.

20 Mechanical strength

20.1 Tools shall have adequate mechanical strength, and shall be so constructed that they withstand rough handling that may be expected.

Compliance is checked by the tests specified in 20.2, 20.3 and 20.4.

*Immediately after the tests, the tool shall withstand the electric strength test as specified in Annex D between **live parts** and **accessible parts**, and **live parts** shall not have become accessible, as specified in Clause 9.*

*Damage to the finish, small dents and cracks which do not reduce **creepage distances** or **clearances** below the values specified in 28.1, or small chips which do not adversely affect protection against shock or moisture are neglected.*

The mechanical safety of the tool as required by this standard shall not be impaired.

If a decorative cover is backed by an inner cover, a fracture of the decorative cover is neglected when the inner cover withstands the test after removal of the decorative cover.

20.2 Blows are applied to the tool by means of the spring-operated impact test apparatus according to Clause 5 of IEC 60068-2-75:1997.

The spring is so adjusted that it causes the hammer to strike with an impact energy as shown in Table 5.

Table 5 – Impact energies

Parts to be tested	Impact energy J
Brush caps	0,5 ± 0,05
Other parts	1,0 ± 0,05

The tool is rigidly supported and three blows are applied to each point of the enclosure which is likely to be weak.

*Where necessary, blows are also applied to **guards**, covers, handles, levers, knobs and the like.*

20.3 For **hand-held tools** and **hand-held lawn and garden machinery**, 20.3.1 applies. For **transportable tools**, 20.3.2 applies. For **ground supported lawn and garden machinery**, requirements are given in the relevant part of IEC 62841-4.

20.3.1 A **hand-held tool** is dropped three times in total on a concrete surface from a height of 1 m. For these three drops, the sample is tested in the three most unfavourable positions the lowest point of the tool being 1 m above the concrete surface. Separable **accessories** are not mounted.

If **attachments** are provided as specified in accordance with 8.14.2, the test is repeated with each **attachment** or combination of **attachments** mounted to a separate tool sample.

20.3.2 A **transportable tool**, placed in its normal operating position, is impacted with a smooth steel sphere having a diameter of (50 ± 2) mm and weighing $(0,55 \pm 0,03)$ kg. If a part of the tool can be impacted from above, the sphere is dropped from a rest position to strike the component. Otherwise, the sphere is suspended by a cord and is allowed to fall from a rest position as a pendulum to strike the area of the tool to be tested. In either case, the vertical travel of the sphere is $(1,3 \pm 0,1)$ m.

A **guard** that becomes disassembled is acceptable, if it can be reassembled to function properly.

Deformation of a **guard** or other part is acceptable, if the part can be restored to its original shape.

Damage to the tool or a portion of the drive system, other than a **guard** is acceptable, if the tool is incapable of **normal operation**.

20.4 Accessible caps of brush holders shall have adequate mechanical strength.

Compliance is checked by inspection and, in case of doubt, by removing and replacing the brushes 10 times, the torque applied when tightening the cap being as shown in Table 6.

Table 6 – Test torques

Blade width of test screwdriver mm	Torque Nm
Up to and including 2,8	0,4
Over 2,8 up to and including 3,0	0,5
Over 3,0 up to and including 4,1	0,6
Over 4,1 up to and including 4,7	0,9
Over 4,7 up to and including 5,3	1,0
Over 5,3	1,25

After this test, the brush holder shall show no damage impairing its further use, the thread, if any, shall not be damaged and the cap shall show no cracks.

The blade width of the test screwdriver must be as large as possible, but must not exceed the length of the recess in the cap. If, however, the thread diameter is smaller than the length of the recess, the blade width must not exceed this said diameter. The torque must not be applied in jerks.

20.5 For all tools that are likely to cut into concealed wiring or their own cord, handles and grasping surfaces, as specified in the instruction manual in accordance with 8.14.2 b) 6), shall have adequate mechanical strength in order to provide insulation between the grasping area

and the output shaft. The relevant part of IEC 62841-2, IEC 62841-3 or IEC 62841-4 specifies if 20.5 does not apply.

Compliance is checked by the following test.

A separate sample, at the discretion of the manufacturer, is to be subjected to a single impact on each handle and each recommended grasping surface in the most unfavourable position. The impacts are carried out from a height of 1 m onto a concrete surface followed by an electric strength test according to Clause D.2 using 1 250 V a.c. between the handles and grasping surfaces in contact with foil and the output shaft of the tool.

21 Construction

21.1 Tools which can be adjusted to suit different voltages, or to different speeds, shall be so constructed that accidental changing of the setting is unlikely to occur, if such a change might result in a hazard.

Compliance is checked by inspection and by manual test.

21.2 Tools shall be so constructed that accidental changing of the setting of **control devices** is unlikely to occur.

Compliance is checked by manual test.

21.3 It shall not be possible to remove parts which ensure the required degree of protection against moisture without the aid of a tool.

Compliance is checked by manual test.

21.4 If handles, knobs and the like are used to indicate the position of switches or similar components, it shall not be possible to fix them in a wrong position if this might result in a hazard.

Compliance is checked by inspection and by manual test.

21.5 Replacement of a flexible cable or cord requiring the moving of a switch which acts also as a terminal for external conductors shall be possible without subjecting internal wiring to undue stress; after repositioning the switch, and before reassembling the tool, it shall be possible to verify whether the internal wiring is correctly positioned.

Compliance is checked by inspection and by manual test.

21.6 Wood, cotton, silk, ordinary paper and similar fibrous or hygroscopic material shall not be used as insulation, unless impregnated.

Insulating material is considered to be impregnated if the interstices between the fibres of the material are substantially filled with a suitable insulant.

Compliance is checked by inspection.

21.7 Driving belts shall not be relied upon to provide the required level of insulation.

This requirement does not apply if the tool incorporates a special design of belt which prevents inappropriate replacement.

Compliance is checked by inspection.

21.8 Insulating barriers of **class II tools**, and parts of **class II tools** which serve as **supplementary insulation** or **reinforced insulation**, and which might be omitted during reassembly after **user maintenance**, shall either:

- be fixed in such a way that they cannot be removed without being seriously damaged; or
- be so designed that they cannot be replaced in an incorrect position, and that, if they are omitted, the tool is rendered inoperable or manifestly incomplete.

Compliance is checked by inspection and by manual test.

This requirement is met if the barrier is so fixed that it can only be removed by breaking or cutting.

*Fixing by means of rivets is allowed, provided that these rivets need not be removed during **user maintenance**.*

Fixing by means of an adhesive is only allowed if the mechanical strength of the joint is at least equal to that of the barrier.

An adequate internal lining of insulation material, or an adequate internal insulating coating on metal enclosures, is considered to be an insulating barrier provided that the coating cannot easily be removed by scraping.

*For **class II tools**, a sleeve on an insulated internal conductor, other than the core of an external flexible cable or cord, is considered to be an adequate insulating barrier, if it can only be removed by breaking or cutting, or if it is clamped at both ends.*

Ordinary lacquering on the inside of metal enclosures, varnished cambric, flexible resin-bonded paper, or the like are not considered to be insulating barriers.

21.9 The insulation of the inner conductors of a flexible cable or cord used as wiring within the tool is considered as **basic insulation**. No additional insulation is required in areas of class I construction. When these conductors are used in areas of **class II construction**, they shall be insulated from accessible metal parts by any of the following:

- the sheath of the **supply cord** itself, provided this sheath is not exposed to undue thermal stress, clamping against accessible metal or other mechanical stress (e.g. pressure or tension) that could cause damage to the sheath; or
- a sleeve, tubing or barrier complying with the requirements of **supplementary insulation**.

Compliance is checked by inspection and, for the determination of thermal stress, by the test of Clause 12.

21.10 Air intake of motor enclosures shall not enable the ingress of foreign bodies that could impair safety.

Compliance is checked by the following test.

It shall not be possible to insert a steel ball of 6 mm diameter under its own weight through the air intake openings other than those adjacent to the fan.

21.11 Class I tools shall be so constructed that, should any wire, screw, nut, washer, spring, brush, brush holder component or similar part become loose or fall out of position, it cannot become so disposed that accessible metal is made live.

Class II tools or **class II constructions** shall be so constructed that, should any such part become loose or fall out of position, it cannot become so disposed that **creepage distances** or

clearances over **supplementary insulation** or **reinforced insulation** are reduced to less than 50 % of the values specified in 28.1.

Class II tools or **class II constructions**, other than those of the all-insulated type, shall be provided with insulating barriers between accessible metal and motor parts and other **live parts**.

For **class I tools**, this requirement can be met by the provision of barriers, or by fixing the parts adequately, and by providing sufficiently large **creepage distances** and **clearances**.

It is not to be expected that two independent parts will become loose or fall out of position at the same time. For electrical connections, spring washers are considered to be adequate for preventing the loosening of the parts.

Wires are considered as likely to become free from terminals or soldered connections, unless they are held in place near to the terminal or termination, independent of the terminal connection or solder.

Short rigid wires are not regarded as liable to come away from a terminal, if they remain in position when the terminal screw is loosened.

Compliance is checked by inspection, by measurement and by manual test.

21.12 Supplementary insulation and reinforced insulation shall be so designed or protected that they are not likely to be impaired by deposition of dirt, or by dust resulting from wear of parts within the tool, to such an extent that **creepage distances** or **clearances** are reduced below the values specified in 28.1.

Ceramic material not tightly sintered and similar materials, and beads alone, shall not be used as **supplementary insulation** or **reinforced insulation**.

Elastomer, natural or synthetic rubber parts used as **supplementary insulation** and/or **reinforced insulation** shall be resistant to ageing, or be so arranged and dimensioned that **creepage distances** are not reduced below the values specified in 28.1, even if cracks occur.

Insulating material in which heating conductors are embedded serves as **basic insulation**, and shall not be used as **reinforced insulation**.

Compliance is checked by inspection, by measurement and, for elastomer and rubber, by the following test.

*Elastomer and rubber parts are aged at a temperature of (100 ± 2) °C for 70 h. After the test, the parts shall withstand the test of Clause D.2 using 75 % of the values indicated in Table D.1. For the test in accordance with Clause D.2, the parts may be tested individually or reassembled in the tool. If a part is tested reassembled in the tool, the test shall only be conducted between **live parts** and **accessible parts**.*

NOTE In case of doubt with regard to materials other than rubber, special tests may be made.

In case of doubt, the following test is carried out to determine, if ceramic material is tightly sintered.

The ceramic material is broken into pieces that are immersed in a solution containing 1 g of fuchsine in each 100 g of methylated spirit. The solution is maintained at a pressure not less than 15 MPa for a period so that the product of the test duration in hours and the test pressure in megapascals is approximately 180.

The pieces are removed from the solution, rinsed, dried and broken into smaller pieces.

The freshly broken surfaces are examined and shall not show any trace of dye visible with normal vision.

21.13 Tools shall be so constructed that internal wiring, windings, commutators, slip rings and the like, and insulation in general, are not exposed to oil, grease or similar substances.

If the construction necessitates that insulation be exposed to oil or grease or similar substance, as in gears and the like, the oil or grease or substance shall have adequate insulating properties so that compliance with the standard is not impaired, and shall have no effect on insulation.

Compliance is checked by inspection and by the tests of this standard.

21.14 It shall not be possible to gain access to brushes without the aid of a tool.

Screw-type brush-caps shall be so designed that, when tightening, two surfaces are clamped together.

Brush-holders, which retain the brushes in position by means of a locking device, shall be so designed that the locking does not depend upon the brush-spring tension, if the loosening of the locking device might make **accessible parts** live.

Screw-type brush-caps, which are accessible from the outside of the tool, shall be of insulating material, or be covered with insulating material; they shall not project beyond the surrounding surface of the tool.

Compliance is checked by inspection.

21.15 Tools employing **liquid systems** shall protect the user against the increased risk of shock due to the presence of liquid under faults of the **liquid system**.

Tools employing **liquid systems** shall be either:

- of **class III construction**; or
- of **class I** or **class II construction** and be provided with a **residual current device** and comply with 14.3, 14.4 and 14.5; or
- of **class I** or **class II construction** and be designed for use in combination with an isolating transformer and comply with 14.3 and 14.4.

Compliance is checked by inspection.

21.16 For tools having compartments to which access can be gained without the aid of a tool and that are likely to be cleaned in **normal use**, the electrical connections shall be arranged so that they are not subject to pulling during cleaning.

Compliance is checked by inspection and by manual test.

21.17 Tools shall be fitted with a **power switch** to control the motor. The actuating member of this switch shall be easily visible and accessible.

Compliance is checked by inspection.

21.17.1 For tools incorporating a switch with a lock-off device, whereby the switch trigger is operated with a squeezing action by closing the fingers towards the palm of the hand, the lock-off system shall be designed to ensure sufficient durability to withstand abuse and environmental conditions to prevent activation of the tool by the switch trigger alone.

Compliance is checked by inspection and by the tests of 21.17.1.1 and, for lock-off devices that are self-restoring to the lock-off position, additionally by the tests of 21.17.1.2.

21.17.1.1 *A sample of the switch and its lock-off system assembled into the relevant tool housing is kept for 1 h in a heating cabinet at 80 °C.*

After the sample has returned to within 5 K of the ambient temperature, the switch lock-off system shall then comply with the test of 21.17.1.3.

21.17.1.2 *A sample of the switch and its lock-off system assembled into the relevant tool housing is operated for the number of cycles in accordance with 23.1.10.2, where one cycle is defined as follows:*

- 1) *the lock-off device is actuated;*
- 2) *the switch is actuated;*
- 3) *the lock-off device or the switch is released as required to restore the switch to the locked state.*

The switch actuations shall be conducted at a rate of 10 to 20 per min. Following the operations as specified above, the sample shall then comply with the test of 21.17.1.3. During this test, the tool need not be connected to the supply.

NOTE The above test can be performed in conjunction with 23.1.10.2.

21.17.1.3 *A push force as specified in Table 7 is applied to the most unfavourable point of the switch actuating member in the direction of the switch actuation for a period of 10 s without prior actuation of the lock-off device. The switch shall not actuate during the application of the specified force. The switch and its lock-off system shall operate as designed after the applied force is terminated.*

Table 7 – Switch trigger force

Trigger type	Force N
Single finger trigger (trigger length < 30 mm)	100
Multi finger trigger (trigger length ≥ 30 mm)	150

21.18 Additional requirements for **power switches** for **hand-held tools** are given in 21.18.1. Additional requirements for **power switches** for **transportable tools** are given in 21.18.2. Additional requirements for **power switches** for **lawn and garden machinery** are given in the relevant part of IEC 62841-4.

21.18.1 For **hand-held tools**, the **power switch** required by 21.17 shall be a **momentary power switch**, with or without a lock-on device, which can be switched on and off by the user without releasing any of the handle(s) or grasping surface(s) required by 19.4.

☐ Text deleted ☐

Compliance is checked by inspection and by manual test.

21.18.1.1 When a **momentary power switch** has a separate action to lock it in the "on" position, the switch shall unlock automatically with a single actuation motion without releasing the grasp on the tool. For tools supplied with more than one switch of which any can be locked on, the lock-on switch(es) shall be within the grasping zone necessary to control the tool, and any one of these switches shall unlock or make ineffective all remaining lock-on devices automatically with a single actuation motion without releasing the grasp on the tool.

Where there is a risk associated with continued locked-on operation as defined by the relevant part of IEC 62841-2, the switch shall not have any locking device to lock it in the "on" position.

Compliance is checked by inspection and by manual test.

21.18.1.2 Where there is a risk associated with inadvertent starting as defined by the relevant part of IEC 62841-2, **power switch** triggers and lock-off devices, if applicable, shall be so located, designed or guarded that inadvertent operation is unlikely to occur.

It shall either not be possible to start the tool when a rigid sphere with a diameter of (100 ± 1) mm is applied to the **power switch** in any direction with a single linear motion;

or

two separate and dissimilar actions shall be necessary before the motor is switched on (e.g. a **power switch** which has to be pushed in before it can be moved laterally to close the contacts to start the motor). It shall not be possible to achieve these two actions with a single grasping motion or a straight line motion.

Compliance is checked by inspection and by manual test.

☐ **21.18.1.Z1** Unless **hand-held tools** are equipped with a **momentary power switch** without lock-on device, voltage recovery following an interruption of the supply shall not give rise to a hazard. The relevant part of EN 62841-2 specifies if this subclause applies and gives specific requirements.

Compliance is checked by inspection. ☐

21.18.2 For **transportable tools**, the **power switch** required by 21.17 shall be able to be easily actuated "on" or "off" without any reasonably foreseeable hazard from the operator's position as specified in the instruction manual in accordance with 8.14.2.

Compliance is checked by inspection.

21.18.2.1 ☐ Unless transportable tools are equipped with a momentary power switch without lock-on device, voltage recovery following an interruption of the supply shall not give rise to a hazard. The relevant part of EN 62841-3 specifies if this subclause applies and gives specific requirements.

Compliance is checked by inspection. ☐

21.18.2.2 An "on"/"off" control shall be capable of being turned off by the operator with a single straight-line motion.

When a flap/cover is provided and covers the stop button it shall do so in a way such that pushing the flap actuates the stop.

Compliance is checked by manual test.

21.18.2.3 A **power switch** shall be located, designed or guarded so that unintentional movement to the “on” position is unlikely.

It shall either not be possible to start the tool when a rigid sphere with a diameter of (100 ± 1) mm is applied to the **power switch** in any direction with a single linear motion;

or

the **power switch** shall have two separate and dissimilar actions before the motor is switched on (e.g. a **power switch** which has to be pushed in before it can be moved laterally to close the contacts to start the motor). It shall not be possible to achieve these two actions with a single grasping or a straight line motion.

Compliance is checked by inspection and by manual test.

21.18.2.4 A push-pull switch shall be turned off by an inward push.

Compliance is checked by inspection.

21.19 Tools shall be so designed that the protection against electric shock is not affected when screws removed during **user maintenance** are incorrectly replaced during reassembly.

*Compliance is checked by removing screws required by each **user maintenance** operation as specified in 8.14.2 and attempting to install them into the improper screw locations of the same or larger diameter during reassembly, using the torque from Table 11, after which **creepage distances** and **clearances** between **live parts** and accessible metal parts shall not have been reduced below the values specified in 28.1.*

21.20 If the tool is marked with the first numeral of the IP system, the relevant requirements of IEC 60529:2013 shall be fulfilled.

Compliance is checked by making the relevant tests.

21.21 Tools shall be so designed that there is no risk of electric shock from charged capacitors when touching the pins of the plug. Capacitors, having a rated capacitance less than or equal to $0,1 \mu\text{F}$, are not considered to entail a risk of electric shock even if connected to the supply side of the switch. This requirement does not apply to capacitors complying with the requirements for **protective impedance** specified in 9.2 and 21.34.

Compliance is checked by the following test, which is made 10 times.

*The tool is operated at **rated voltage**.*

*The **power switch** is then moved to the "off" position and the tool is disconnected from the supply by means of the plug.*

One second after disconnection, the voltage between the pins of the plug is measured with an instrument which does not appreciably affect the value to be measured.

The voltage shall not exceed 34 V.

21.22 Non-detachable parts, which provide the necessary degree of protection against electric shock, moisture, or contact with moving parts, shall either require removal with the aid of a tool or be fixed in a reliable manner.

Snap-in devices used for fixing such parts shall have an obvious locked position. The fixing properties of snap-in devices used in parts which are likely to be removed shall not deteriorate.

Compliance is checked by inspection or by the following tests.

Parts which are likely to be removed are disassembled and assembled 10 times before the test is carried out.

The tool is at ambient temperature. However, in cases where compliance may be affected by temperature, the test is also carried out immediately after the tool has been operated under the conditions specified in Clause 12.

The test is applied to all parts which are likely to be detachable, whether or not they are fixed by screws, rivets, or similar parts.

A force is applied without jerks for 10 s in the most unfavourable direction to those areas of the cover or part which are likely to be weak. The force is as follows:

- push force* *50 N;*
- pull force*
 - a) if the shape of the part is such that the fingertips cannot easily slip off* *50 N;*
 - b) if the projection of the part which is gripped is less than 10 mm in the direction of removal* *30 N.*

The push force is applied by means of a rigid test probe with the dimensions of the test probe B of IEC 61032:1997, but without any articulation.

The pull force is applied by a suitable means such as a suction cup, so that the test results are not affected.

While the pull test of a) or b) is being applied, the test fingernail shown in Figure 1 is inserted in any aperture or joint with a force of 10 N. The fingernail is then slid sideways with a force of 10 N; it is not twisted or used as a lever.

If the shape of the part is such that an axial pull is unlikely, no pull force is applied, but the test fingernail shown in Figure 1 is inserted in any aperture or joint with a force of 10 N, and is then pulled for 10 s by means of the loop with a force of 30 N in the direction of removal.

If the cover or part is likely to be subjected to a twisting force, a torque as detailed below is applied at the same time as the pull or push force:

- for major dimensions up to and including 50 mm* *2 Nm;*
- for major dimensions over 50 mm* *4 Nm.*

This torque is also applied when the test fingernail is pulled by means of the loop.

If the projection of the part which is gripped is less than 10 mm, the above torque is reduced to 50 % of the value.

Parts shall not become detached, and they shall remain in the locked position.

21.23 Handles, knobs, grips, levers and the like shall be fixed in a reliable manner so that they will not work loose, if loosening might result in a hazard.

Compliance is checked by inspection, by manual test, and by trying to remove the handle, knob, grip or lever applying, for 1 min, a 30 N axial force either pushing or pulling.

21.24 Storage hooks and similar devices for flexible cords shall be smooth and well rounded.

Compliance is checked by inspection.

21.25 Current-carrying parts and other parts, the corrosion of which might result in a hazard, shall be resistant to corrosion under normal conditions of use.

Compliance is checked by verifying that, after the tests of Clause 15, the relevant parts show no sign of corrosion. Stainless steel and similar corrosion-resistant alloys and plated steel are considered to be satisfactory for the purpose of this requirement.

NOTE Examples of causes of corrosion are the incompatibility of materials and effects of heating.

21.26 Tools having parts where reliance is based upon **safety extra-low voltage** to provide the necessary degree of protection against electric shock, shall be so designed that the insulation between parts operating at **safety extra-low voltage** and other **live parts** complies with the requirements for **double insulation** or **reinforced insulation**.

*Compliance is checked by the tests specified for **double insulation** or **reinforced insulation**.*

21.27 Parts separated by **protective impedance** shall comply with the requirements for **double insulation** or **reinforced insulation**.

*Compliance is checked by the tests specified for **double insulation** or **reinforced insulation**.*

21.28 Shafts of operating knobs, handles, levers and the like shall not be live unless the shaft is not accessible when the knob, handle, lever and the like is removed.

Compliance is checked by inspection and by applying the test probe B of IEC 61032:1997 after removal of the knob, handle, lever, or the like, even with the aid of a tool.

21.29 For constructions other than those of class III, handles, levers and knobs which are held or actuated shall not become live in the event of an insulation fault.

If these handles, levers or knobs are of metal, and if their shafts or fixings are likely to become live in the event of a **basic insulation** fault, they shall either be adequately covered by insulating material, or their **accessible parts** shall be separated from their shafts or fixings by insulation.

For **transportable tools** and **lawn and garden machinery** of **class I**, this requirement does not apply to handles, levers and knobs, other than those of electrical components, if they are reliably connected to an earthing terminal or earthing contact or separated from **live parts** by earthed metal.

Compliance of the insulating covering or material is checked by inspection, and by the electric strength test in Clause D.2 with 1 250 V applied.

21.30 For all tools that are likely to cut into concealed wiring or their own cord, handles and grasping surfaces, as specified in the instruction manual in accordance with 8.14.2 b) 6), shall be formed of insulating material or, when of metal, shall be either adequately covered by insulating material or their **accessible parts** shall be separated by insulating barrier(s) from

accessible metal parts that may become live by the output shaft. These insulating barriers are not to be regarded as **basic insulation**, **supplementary insulation** or **reinforced insulation**.

If a stick type auxiliary handle is provided with such tool, it shall be insulated and be provided with a flange having a height not less than 12 mm above the grasping surface between the grasping area and **accessible parts** that may become live by the output shaft.

The relevant part of IEC 62841-2, IEC 62841-3 or IEC 62841-4 specifies if 21.30 does not apply.

Compliance is checked by inspection and by the tests of 20.5.

21.31 For **class II tools**, capacitors shall not be connected to accessible metal parts, and their casings, if of metal, shall be separated from accessible metal parts by **supplementary insulation**.

This requirement does not apply to capacitors complying with the requirements for **protective impedance** specified in 9.2 and 21.34.

*Compliance is checked by inspection and by the tests specified for **supplementary insulation**.*

21.32 Capacitors shall not be connected between the contacts of a **thermal cut-out**.

Compliance is checked by inspection.

21.33 Lamp holders shall be used only for the connection of lamps.

Compliance is checked by inspection.

21.34 Protective impedance shall consist of at least two separate components, the impedance of which is unlikely to change significantly during the lifetime of the tool. If any one of the components is short-circuited or open-circuited, the values specified in 9.2 shall not be exceeded.

Resistors complying with 14.1 a) of IEC 60065:2011 and capacitors complying with 14.2 of IEC 60065:2011 are considered to comply with this requirement.

A single capacitor with a rated voltage of at least that of the **rated voltage** of the tool that fulfils subclass Y1 of IEC 60384-14 may be employed instead of two separate components.

Compliance is checked by inspection and by measurement.

21.35 Dust collection

Tools as identified in the relevant part of IEC 62841-2 or IEC 62841-3, which produce a considerable amount of dust, shall have either an integral dust collection/suction device or have dust outlet(s) designed which allow the mounting of external suction device(s) for evacuating the by-products of the working process. These dust outlets shall direct the discharge away from the operator and they along with any external suction device(s) for evacuating the by-products of the working process shall not impede the **normal use** of the tool.

Compliance is checked by inspection.

22 Internal wiring

22.1 Wireways shall be smooth and free from sharp edges.

Wires shall be protected so that they do not come into contact with burrs, cooling fins, etc., which may cause damage to the insulation of conductors.

Holes in metal through which insulated wires pass shall be provided with bushings or, unless required otherwise in the relevant part of IEC 62841-2, IEC 62841-3 or IEC 62841-4, shall have smooth, well-rounded edges. A radius of 1,5 mm is considered to be well rounded.

Wiring shall be effectively prevented from coming into contact with moving parts.

Compliance is checked by inspection.

22.2 Internal wiring shall be either so rigid and so fixed or insulated that **creepage distances** and **clearances** cannot be reduced below the values specified in 28.1.

Compliance is checked by inspection and by the tests of 28.1.

When sleeving is used as **supplementary insulation** on internal wiring, it shall be retained in position by positive means. A sleeve is considered to be fixed by positive means if it can only be removed by breaking or cutting, or if it is clamped at both ends.

Compliance is checked by inspection and by manual test.

22.3 Conductors identified by the colour combination green or green/yellow shall not be connected to terminals other than earthing terminals.

Compliance is checked by inspection.

22.4 Aluminium wires shall not be used for internal wiring. Windings of a motor are not considered as internal wiring.

Connections to aluminium windings shall consider the effects of possible corrosion between aluminium and other metals and comply with the requirements of 26.4.

Compliance is checked by inspection.

22.5 Stranded conductors shall not be consolidated by lead-tin soldering where they are subjected to contact pressure, unless the clamping means is so designed that there is no risk of bad contact due to cold flow of the solder.

Consolidation of a stranded conductor by lead-tin soldering is allowed if spring terminals are used; securing the clamping screws alone is not considered adequate.

Soldering of the tip of a stranded conductor is allowed.

Compliance is checked by inspection.

22.6 Different parts of a tool that can move relative to each other

- a) in **normal use**,
 - b) during adjustment operations,
- or

c) during **user maintenance**

shall not cause undue stress to electrical connections and internal conductors, including those providing earthing continuity. Flexible metallic tubes shall not cause damage to the insulation of the conductors contained within them. Open-coil springs shall not be used to protect the wiring. If a coiled spring, the turns of which touch one another, is used for this purpose, there shall be an adequate insulating lining in addition to the insulation of the conductors.

This requirement does not apply to movements of parts with small amplitudes caused by vibration.

NOTE Examples of an adequate insulating lining are flexible cords complying with IEC 60227 or IEC 60245.

Compliance is checked by inspection and by the following test.

*If flexing occurs in **normal use**, the tool is placed in the normal position of use.*

With no power applied, the movable part is moved backwards and forwards, so that the conductor is flexed through the largest angle allowed by the construction, the rate of flexing being a minimum of 6 per minute. The number of flexings is

- 10 000, for conductors/connections flexed during **normal use**;
- 2 000, for conductors/connections flexed during adjustments;
- 100, for conductors/connections flexed during **user maintenance**.

A flexing is one movement, either backwards or forwards.

*After the test, the tool shall withstand the electric strength test of Annex D between **live parts** and **accessible parts** and **live parts** shall not have become accessible, as specified in Clause 9.*

23 Components

23.1 Components referenced in this standard shall comply with the safety requirements specified in the referenced IEC standards, as far as they reasonably apply.

Batteries are not regarded as components, but as part of the tool. They shall comply with the applicable requirements as specified in Annexes K and L.

If components are marked with their operating characteristics, the conditions under which they are used in the tool shall be in accordance with these markings, unless a specific exception is made.

Compliance with the IEC standard for the relevant component does not necessarily ensure compliance with the requirements of this standard.

*Unless otherwise specified, the requirements of Clause 28 of this standard apply between **live parts** of components and **accessible parts** of the tool.*

Unless components have been previously tested and found to comply with the relevant IEC standard for the number of cycles specified, they are tested in accordance with 23.1.1 to 23.1.11.

23.1.1 Capacitors in auxiliary windings of motors shall be marked with their **rated voltage** and their rated capacitance.

Compliance is checked by inspection.

23.1.2 Capacitors for radio interference suppression shall comply with IEC 60384-14.

Compliance is checked by inspection.

23.1.3 Small lampholders similar to E10 lampholders shall comply with the requirements for E10 lampholders in IEC 60238. However, they need not accept a lamp with an E10 cap complying with the current edition of Standard Sheet 7004-22 of IEC 60061-1.

Compliance is checked by inspection.

23.1.4 Isolating transformers or **safety isolating transformers**, except incorporated transformers as defined in IEC 61558-1, shall comply with IEC 61558-2-4 or IEC 61558-2-6, respectively. Switch mode power supply units and transformers for switch mode power supply units shall comply with IEC 61558-2-16.

Compliance is checked by inspection.

Incorporated transformers shall comply with IEC 61558-2-4 or IEC 61558-2-6 except for marking requirements.

Compliance is checked by the relevant tests of IEC 61558-2-4 or IEC 61558-2-6. These tests shall be performed in the tool.

23.1.5 Appliance couplers shall either comply with IEC 60320 or the manufacturer shall inform the user in the instructions for use to connect the tool only by means of the appropriate connector specified by the manufacturer.

Compliance is checked by inspection.

23.1.6 Automatic temperature controls containing electromechanical contacts that cycle in **normal use**, shall have suitable endurance for their intended application.

Compliance is checked by evaluating the endurance of a cycling control according to Clause 17 of IEC 60730-1:2010 under the conditions occurring in the tool. The number of cycles to be used is:

- for a **thermostat**, 10 000 cycles of operation;
- for a **temperature limiter**, 1 000 cycles of operation;
- for a **self-resetting thermal cut-out**, 300 cycles of operation;
- for a voltage-maintained **non self-resetting thermal cut-out**, 1 000 cycles of operation;
- for other **non self-resetting thermal cut-outs**, 30 cycles of operation.

Automatic controls which comply with the requirements of IEC 60730-1:2010, and which are used in accordance with their marking, are considered to meet the requirements of this standard (the term "marking" includes documentation and declaration as specified in Clause 7 of IEC 60730-1:2010).

The tests of Clause 17 of IEC 60730-1:2010 are not carried out on automatic controls which operate during Clause 12, if the tool meets the requirements of this standard when they are short-circuited.

*A specific exception with regard to the testing of **thermostats** and **temperature limiters** is made in Note b) of Table 1 of Clause 12.*

23.1.7 *The testing of components which have to comply with other standards is, in general, carried out separately, according to the relevant standard as follows.*

If the component is marked and used in accordance with its marking, it is tested in accordance with its marking, the number of samples being that required by the relevant standard.

In particular, components not mentioned in Table 1 of Clause 12 are tested as a part of that tool.

23.1.8 *Components that have not been separately tested and found to comply with the component standards as references in 23.1 or components that are not marked or not used in accordance with their marking, are tested in accordance with the referenced relevant standard under the conditions occurring in the tool.*

When an IEC standard for a component is not referenced in 23.1, there are no additional tests specified.

23.1.9 *For capacitors connected in series with a motor winding, the voltage across the capacitor shall not exceed 1,1 times the rated voltage of the capacitor, when the tool is operated at a voltage equal to 1,1 times **rated voltage** and under no-load.*

23.1.10 Switches shall be so constructed that there will be no failure that might impair compliance with this standard.

Compliance is checked by the following.

Switches, if separately tested and found to comply with IEC 61058-1:2008, shall meet the requirements specified in 23.1.10.1.

Switches which have not been separately tested and found to comply with IEC 61058-1:2008 or do not meet the requirements of 23.1.10.1, are tested as in 23.1.10.2 to 23.1.10.3.

23.1.10.1 Switches shall be rated and classified as follows.

Power switches shall be rated as follows:

- for a voltage not less than the **rated voltage** of the tool;
- for a current not less than the **rated current** of the tool;
- for a.c., if the tool is rated for a.c.;
- for d.c., if the tool is rated for d.c.

Electronic **power switches** shall, as a minimum, be classified for Continuous Duty in accordance with IEC 61058-1:2008.

Power switches shall further be classified with respect to load:

- switches for motor-operated tools and motor-operated **lawn and garden machinery**: for resistive and motor load in accordance with 7.1.2.2 of IEC 61058-1:2008, if the switch would encounter this load in **normal use**;
- switches for magnetically driven tools and magnetically driven **lawn and garden machinery**: for inductive load in accordance with 7.1.2.8 of IEC 61058-1:2008, if the switch would encounter this load in **normal use**;
- alternatively, switches may be regarded as switches for a declared specific load in accordance with 7.1.2.5 of IEC 61058-1:2008 and may be classified based upon the load conditions encountered in the tool in **normal use**.

Ratings and load classifications for switches other than **power switches** shall be based on the conditions encountered in the tool.

Switches shall further be classified as follows with respect to endurance:

- **power switches** for **hand-held tools**: for 50 000 operating cycles;
- **power switches** for **transportable tools** and **lawn and garden machinery**: for 10 000 operating cycles;
- **power switches** which possess series electronics must also endure 1 000 operating cycles with the electronics bypassed;

NOTE 1 Switches without any declared endurance with the electronics bypassed have been tested, by default, to 1 000 operating cycles in accordance with IEC 61058-1:2008.

- switches other than **power switches**, such as speed selector switches, which are likely to be switched under electrical load: for 1 000 operating cycles. However, this test is not required, if the requirements of this standard are met with the switch short-circuited;
- switches other than **power switches** that either
 - are intended for operation without electrical load, and which can be operated only with the aid of a tool or are interlocked so that they cannot be operated under electrical load; or
 - provide a motor direction reversing function; or
 - are switches for 20 mA load as classified in 7.1.2.6 of IEC 61058-1:2008
 are not required to possess any particular endurance characteristic.

NOTE 2 Motor reversing endurance is tested in 18.7.

Compliance is checked by inspection of the markings on the switch and by the documentation and certificate provided with the switch.

23.1.10.2 The endurance properties of switches shall be adequate.

Compliance is checked by submitting three samples of the switch to the accelerated cycle endurance test of 17.2.4.4 of IEC 61058-1:2008, but with load conditions as specified in either 23.1.10.2.1 or 23.1.10.2.2 and with the number of operating cycles as specified below.

Power switches for hand-held tools are tested for 50 000 operating cycles. **Power switches for transportable tools and lawn and garden machinery** are tested for 10 000 operating cycles.

*If a **power switch** is comprised of mechanical contacts in series with electronic circuitry containing one or more semiconductor switching devices (SSD) as defined in IEC 61058-1:2008 where the circuitry provides a protective function by reducing the current during switch operation, then:*

- *on three additional samples, the electronic circuitry shall be bypassed and the test repeated for at least 1 000 operating cycles; or*
- *the protective function shall be considered to be a **safety critical function** and comply with the greater of the performance levels for **power switches** in 18.8.*

*Switches other than **power switches**, such as speed selector switches, which are likely to be switched while energized, are tested as described above, but for 1 000 operating cycles only for the load conditions encountered in **normal use**.*

*Switches, other than **power switches**, intended for operation without electrical load, and which can be operated only with the aid of a tool or are interlocked so that they cannot be operated under electrical load, are not subjected to the tests of 17.2.4.4 of IEC 61058-1:2008.*

Reverse switches are not subjected to the tests of 17.2.4.4 of IEC 61058-1:2008, as they are tested in 18.7.

Switches for 20 mA load as classified in 7.1.2.6 of IEC 61058-1:2008 are also not subjected to the tests of 17.2.4.4 of IEC 61058-1:2008.

*After completion of the above tests, the switch shall be able to be turned on and off and comply with the insulating compliance (TE3) of 17.2.5.3 of IEC 61058-1:2008 for **basic insulation**.*

23.1.10.2.1 *For switches tested with an external load, the load conditions are as follows:*

Power switches for motor-operated tools and motor-operated **lawn and garden machinery** are regarded as classified to 7.1.2.2 of IEC 61058-1:2008. They are tested with 6 times I-M making current and a power factor $0,6 \pm 0,05$, and with I-M breaking current and a power factor $\geq 0,9$, the I-M current being the **rated current** of the tool.

Power switches for magnetically driven tools and magnetically driven **lawn and garden machinery** are regarded as classified to 7.1.2.8 of IEC 61058-1:2008. They are tested with 6 times I-I making current and a power factor $0,6 \pm 0,05$, and with I-I breaking current and a power factor $0,6 \pm 0,05$, the I-I current being the **rated current** of the tool.

*Switches other than **power switches**, but which would encounter the same load conditions as **power switches** in **normal use**, shall be tested with the corresponding load conditions above.*

23.1.10.2.2 *For switches tested utilizing the motor or magnetic load encountered in the tool, the switch is tested at **rated voltage** for the required number of operating cycles, each cycle composed as follows:*

- 1) *With the tool at rest, the switch is closed without any mechanical load applied to the tool.*
- 2) *The switch is opened with the tool loaded to **rated current** or **rated input**.*

The operating cycles shall be conducted as quickly as possible but need not meet the requirements of 17.2.3.4.1 of IEC 61058-1:2008.

23.1.10.3 The breaking capacity of **power switches** of motor-operated tools and **lawn and garden machinery** shall be adequate.

Compliance is checked by the locked-rotor test (TC9) of 17.2.4.9 of IEC 61058-1:2008 with a current of 6 ´ I-M. Alternatively, the test is performed with the switch incorporated in the tool with the motor locked, each “on” period being not more than 0,5 s, and each “off” period being not less than 10 s.

*After this test the **power switch** shall have no electrical or mechanical failure. If the switch operates properly in the “on” and “off” positions at the end of the test, it is considered to have no mechanical or electrical failures.*

23.1.11 Electronic **power switches**, without series mechanical contact separation (air gap), are allowed, provided the requirements of 18.6 and 18.8 are met.

NOTE Electronic **power switches** are considered to provide a **safety critical function**.

23.2 Tools shall not be fitted with

- switches or automatic controls in flexible cords, however **protective devices** such as **RCDs** are allowed;
- devices, except for earthing conductors, which are intended to cause the protection device in the fixed wiring to operate in the event of a fault in the tool;

- **thermal cut-outs** which can be reset by a soldering operation.

Compliance is checked by inspection.

23.3 Protection devices (e.g. overload or over-temperature protection devices) or circuits that switch off the tool shall be of the non-self-resetting type where there is a risk associated with inadvertent starting as specified in the relevant part of IEC 62841-2 (by 21.18.1.2), IEC 62841-3 or IEC 62841-4.

Electronic speed and load regulators are not considered to be protection devices, if they do not switch off the tool but reduce the speed of the tool as a load is applied and increase the speed of the tool when the load is removed. An **RCD** is not considered a protection device.

Resetting a protection device by switching the tool off and on with the **power switch** is considered to be a non-self-resetting action.

Compliance is checked by inspection.

23.4 Plugs and socket-outlets **for extra-low voltage** circuits, and those used as terminal devices for heating elements, shall not be interchangeable with mains plugs and socket-outlets listed in IEC 60884, IEC/TR 60083 or IEC 60906-1 or with connectors and appliance inlets complying with the standard sheets of IEC 60320-1.

Compliance is checked by inspection.

23.5 Motors connected to the supply mains, and having basic insulation which is inadequate for the rated voltage of the tool, shall comply with the requirements of Annex B.

Compliance is checked by the tests of Annex B.

24 Supply connection and external flexible cords

24.1 Tools shall be provided with one of the following means of connection to the supply:

- a **supply cord** with a minimum length of 1,8 m and with a plug;
- a **supply cord** with a minimum length of 1,8 m and without a plug, the information for connection shall be given in the instructions in accordance with 8.14.2 a);
- an appliance inlet having at least the same degree of protection against moisture as required for the tool;
- a **supply cord** with a length between 0,2 m and 0,5 m and fitted with a plug or other connector having at least the same degree of protection against moisture as required for the tool.

Plugs, connectors and inlets shall be suitable for the ratings of the tool.

Compliance is checked by inspection and by measurement.

The cord is measured from where it exits the tool to where it enters the plug, if one is provided, or to the end of the cord, if there is no plug.

24.2 **Supply cords** shall be assembled to the tool by one of the following methods:

- **type X attachment;**
- **type Y attachment;**
- **type Z attachment**, if allowed in the relevant part of IEC 62841-2, IEC 62841-3 or IEC 62841-4.

Supply cords with **type X attachment** shall be specially prepared cords only available from the manufacturer or his service agent. A specially prepared cord may also include a part of the tool.

Compliance is checked by inspection and, if necessary, by manual test.

24.3 Plugs shall not be fitted with more than one flexible cord.

Compliance is checked by inspection.

24.4 Supply cords shall be not lighter than:

- ordinary rubber sheathed flexible cord (code designation 60245 IEC 53); or
- ordinary polyvinyl chloride sheathed flexible cord (code designation 60227 IEC 53).

Polyvinyl chloride insulated flexible cords shall not be used for tools having external metal parts, the temperature rise of which exceeds 75 K during the test of Clause 12.

NOTE 1 In the United States of America, the following conditions apply:

Supply cords shall be not lighter than Junior Hard service cord in accordance with the National Electrical Code, NFPA 70,

Attachment plugs and cords shall be equal to or greater than the rating of the tool.

NOTE 2 In Canada, the following conditions apply:

Supply cords shall be not lighter than Hard Usage cord in accordance with the Canadian Electrical Code, Part 1.

Attachment plugs and cords shall be equal to or greater than the rating of the tool.

Compliance is checked by inspection and by measurement.

24.5 Supply cords shall have a nominal cross-sectional area not less than those shown in Table 8.

Table 8 – Minimum cross-sectional area and AWG sizes of supply cords

Rated current of the tool A	Nominal cross-sectional area mm ²	AWG size ^a
Up to and including 6	0,75	18
Over 6 up to and including 10	1	
Over 10 up to and including 12	1,5	17
Over 12 up to and including 13		16
Over 13 up to and including 16		14
Over 16 up to and including 18	2,5	12
Over 18 up to and including 25		
^a AWG stands for American Wire Gauge as defined in ASTM B 258-02		

*Compliance is checked by inspection of the markings on the **supply cord**.*

24.6 For **class I tools**, the **supply cord** shall be provided with a green or green/yellow core; it shall be connected to the internal earthing terminal of the tool, and to the earthing contact of the plug.

Compliance is checked by inspection.

24.7 Conductors of **supply cords** shall not be consolidated by lead-tin soldering where they are subject to contact pressure, unless the clamping means is so designed that there is no risk of a bad contact due to cold flow of the solder.

Compliance is checked by inspection.

The requirement may be met by using spring terminals. Securing the clamping screws alone is not considered adequate.

24.8 For all types of attachment, moulding together the **supply cord** to the enclosure or part of it shall not affect the insulation of the cord.

Compliance is checked by inspection.

24.9 Tools provided with a **supply cord** shall be constructed so that the **supply cord** is protected against damage where it enters the tool.

This shall be achieved by either:

- a flexible cord guard; or
- a cord inlet; or
- a bushing.

Compliance is checked by inspection.

24.10 Cord inlets and bushings shall:

- be so shaped as to prevent damage to the **supply cord**;
- be reliably fixed;
- not be removable without the aid of a tool.

Compliance is checked by inspection and by manual test.

24.11 Tools, other than **transportable tools**, provided with a **supply cord** that is flexed while in operation shall be constructed so that the **supply cord** is protected against excessive flexing where it enters the tool.

Compliance is checked by the following tests a) and b).

a) *The part of the tool fitted with the **supply cord** and its entry system is fixed in the oscillating member of an apparatus similar to that shown in Figure 2. The distance X, as shown in Figure 2, between the axis of oscillation and the point where the **supply cord** enters the tool, is adjusted so that when the oscillating member moves over its full range, the cord and load make the minimum lateral movement.*

*A weight, having the mass of the tool as specified in 5.17, but not less than 2 kg or more than 6 kg, is attached to the **supply cord**.*

*The oscillating member is moved backwards and forwards through an angle of 90° (45° on either side of the vertical), the number of flexings being 20 000 and the rate of flexing 60 per min. A flexing is one movement, either backwards or forwards. After 10 000 flexings, the sample is turned through 90° about the centre line of the **supply cord** entry and the final 10 000 flexings are conducted.*

b) *For tools provided with a cord guard, the cord anchorage and the terminal screws are loosened, without removing the conductors of the **supply cord**. However, if the cord guard is clamped under the cord anchorage, the cord anchorage is not loosened.*

The tool is then lifted by the cord guard, without jerks, over a distance of approximately 500 mm in approximately 1 s, and replaced on a support. The operation is made 10 times.

During this test, the cord guard shall not slip out of its location.

After the tests a) and b), if applicable, the following results shall not have occurred:

- disconnection of any conductor from its terminal;*
- a breakage of more than 10 % of the strands of any conductor.*

NOTE Conductors include earthing conductors.

24.12 Supply cords of tools, other than **transportable tools**, that are flexed while in operation shall be protected against excessive bending at the inlet opening of the tool.

The cord guard, if any, shall be fixed in a reliable manner, and shall be of such a design that they project outside the tool for a distance beyond the inlet opening of at least five times the overall diameter of the cable or cord delivered with the tool.

Compliance is checked by inspection, by measurement and by the following test.

*The tool is fitted with a **supply cord** that extends approximately 100 mm from the end of the **supply cord** entry or the cord guard, if any.*

*The tool is so held that the axis of the **supply cord** entry or cord guard, if any, where the cord leaves it, projects upwards at an angle 45° to the horizontal when the **supply cord** is free from stress.*

*A mass equal to $10 D_c^2 g$ is then attached to the free end of the **supply cord**. D_c is the external diameter of the **supply cord** supplied with the tool in mm.*

*Immediately after the mass has been attached, the radius of the curvature of the **supply cord** shall not be less than $1,5 D_c$ anywhere along the length of the **supply cord**.*

24.13 Tools provided with a **supply cord** shall have a cord anchorage. The cord anchorage shall relieve conductors from strain, including twisting, at the terminals and protect the insulation of the conductors from abrasion.

It shall not be possible to push the cord into the tool to such an extent that the cord, or internal parts of the tool, could be damaged.

Compliance is checked by inspection, by manual test, and by the following test.

A mark is made on the cord while it is subjected to the pull force shown in Table 9, at a distance of approximately 20 mm from the cord anchorage or other suitable point.

The cord is then pulled, without jerking, for 1 s in the most unfavourable direction with the force specified. The test is carried out 25 times.

The cord, unless on an automatic cord reel, is then subjected to a torque that is applied as close as possible to the tool. The torque is specified in Table 9 and is applied for 1 min.

Table 9 – Pull and torque value

Mass of tool as specified in 5.17 kg	Pull N	Torque Nm
Up to and including 1	30	0,1
Over 1 up to and including 4	60	0,25
Over 4	100	0,35

During the tests, the cord shall not be damaged and shall show no appreciable strain at the terminals. The pull force is reapplied and the cord shall not be longitudinally displaced by more than 2 mm.

24.14 Cord anchorages shall either be so arranged that they are only accessible with the aid of a tool, or be so designed that the cord can only be fitted with the aid of a tool.

Compliance is checked by inspection.

24.15 Cord anchorages shall be so designed or located that:

- the cord cannot touch the clamping screws of the cord anchorage, if these screws are accessible, unless they are separated from accessible metal parts by **supplementary insulation**;
- the cord is not clamped by a metal screw which bears directly on the cord;
- glands are not used as cord anchorages;
- for **class I tools**, if an insulation fault on the cord could make accessible metal parts live, they are of insulating material or are provided with an insulating lining complying with the requirements for **basic insulation**. The sheath of the cord is considered adequate for this purpose;
- for **class II tools**, they are of insulating material or are insulated from accessible metal parts by insulation complying with the requirements for **supplementary insulation**. The sheath of the cord alone is not considered to fulfil this requirement.

Compliance is checked by inspection.

24.16 For **type X attachments**, cord anchorages shall be designed or located that:

- replacement of the cord is easily possible;

- it is clear how the relief from strain and the prevention of twisting are to be obtained;
- screws, if any, which have to be operated when replacing the cord, do not serve to fix any other component, unless, when omitted or incorrectly mounted, they render the tool inoperative or clearly incomplete, or unless the parts intended to be fastened by them cannot be removed without the aid of a tool during the replacement of the cord;
- in the case of labyrinths, these labyrinths cannot be bypassed in such a way that the test of 24.13 is not withstood;
- at least one part of the cord anchorage is securely fixed to the tool or to a functional part of the tool such as the switch, terminal block or the like, unless it is part of the specially prepared cord.

Compliance is checked by inspection, and by the test of 24.13 under the following conditions.

The conductors are introduced into the terminals, the terminal screws, if any, being tightened just sufficiently to prevent the conductors from easily changing their position. The cord anchorage is used in the normal way, the clamping screws, if any, being tightened with a torque equal to two-thirds of that specified in 27.1.

Screws of insulating material bearing directly on the cord are fastened with two-thirds of the torque specified in column I of Table 11; the length of the slot in the screw head being taken as the nominal diameter of the screw.

24.17 For **type X attachment**, production methods such as tying the cord into a knot, or tying the ends with string, are not allowed.

Compliance is checked by inspection.

24.18 The space for the **supply cord** provided inside, or as a part of the tool for **type X attachment** shall be so designed:

- as to permit checking, before fitting the cover, if any, that the conductors are correctly connected and positioned;
- that covers, if any, can be fitted without risk of damage to the supply conductors or their insulation;
- that the uninsulated end of the conductor, should it become free from a terminal, cannot come into contact with **accessible parts**, unless the cord is provided with terminations that are unlikely to slip free of the conductor.

*Compliance is checked by inspection and, for **type X attachment**, by the following additional test.*

For pillar terminals where the conductors are not separately clamped at a distance of 30 mm or less from the terminal, and for other terminals with screw clamping, the clamping screws or nuts are loosened in turn. Without removing the conductor from the conductor space, a force of 2 N is applied to the wire in any direction and adjacent to the terminal, screw or stud. The uninsulated end of the conductor shall not then come into contact with accessible metal parts or any other metal part connected thereto.

For pillar terminals, where the conductors are separately clamped at a distance of 30 mm or less from the terminal, the tool is considered to meet the requirement that the uninsulated end of the conductor must not come into contact with accessible metal parts.

24.19 Appliance inlets shall:

- be so located or enclosed that **live parts** are not accessible during insertion or removal of the connector;
- be so placed that the connector can be inserted without difficulty;

- be so placed that, after insertion of the connector, the tool is not supported by the connector when in any position of **normal use** on a horizontal flat surface.

Compliance is checked by inspection and, with regard to the first requirement, by means of the test probe B of IEC 61032:1997, for tool inlets other than those standardized in IEC 60320.

Tools provided with appliance inlets complying with IEC 60320 are considered to comply with the first requirement.

24.20 Interconnection cords shall comply with the requirements for the **supply cord**, except that

- the cross-sectional area of the conductors of the cord is determined on the basis of the maximum current carried by the conductor during the test of Clause 12;
- the insulation of the conductor shall be adequate for its **working voltage**;
- the test of 24.11 is restricted to the range of motion of the tool during **normal use**.

NOTE The maximum current carried by the conductor during the test of Clause 12 is not necessarily the **rated current** of the tool.

Compliance is checked by inspection and by measurement.

24.21 Interconnection cords shall not be detachable without the aid of a tool if compliance with this standard is impaired when they are disconnected.

Compliance is checked by inspection.

25 Terminals for external conductors

25.1 Tools shall be provided with terminals or equally effective devices for the connection of external conductors. The terminals shall only be accessible with the aid of a tool.

Screws and nuts shall not serve to fix any other component, except that they may also clamp internal conductors, if these are so arranged that they are unlikely to be displaced when fitting the supply conductors.

Compliance is checked by inspection and by manual test.

For tools with **type X attachment**, soldered connections may be used for the connection of external conductors, provided that the conductor is so positioned or fixed that reliance is not placed upon the soldering alone to maintain the conductor in position, unless barriers are provided so that **creepage distances** and **clearances** between **live parts** and other metal parts cannot be reduced to less than 50 % of the values specified in 28.1, should the conductor become free at the soldered joint.

For **type Y attachment** and **type Z attachment**, soldered, welded, crimped and similar connections may be used for the connection of external conductors; moreover, for **class II tools**, the conductor shall be so positioned or fixed that reliance is not placed upon the soldering, crimping, or welding alone to maintain the conductor in position, unless barriers are provided so that **creepage distances** and **clearances** between **live parts** and other metal parts cannot be reduced to less than 50 % of the values specified in 28.1, should the conductor become free at the soldered or welded joint, or slip out of the crimped connection.

It is not to be expected that two independent fixings will become loose at the same time.

Conductors connected by soldering are not considered to be adequately fixed, unless they are held in place near to the termination, independently of the solder; but "hooking in" before soldering is, in general, considered to be a suitable means for maintaining the conductors of a

power **supply cord** other than a tinsel cord in position, provided the hole through which the conductor is passed is not unduly large.

The terminals of a component (such as a switch) built into the tool may be used as terminals intended for external conductors.

Conductors connected to terminals or terminations by other means are not considered to be adequately fixed, unless an additional fixing is provided near the terminal or termination; this additional fixing, in the case of stranded conductors, clamps both the insulation and the conductor.

Compliance is checked by inspection and by measurement.

25.2 Terminals for **supply cords** shall be suitable for their purpose.

Compliance is checked by inspection and by applying a pull of 5 N to the connection.

After the test, the connections shall show no damage which could impair compliance with this standard.

25.3 For tools with **type X attachment**, terminals shall be so fixed that, when the clamping means is tightened or loosened, the terminal does not work loose, internal wiring is not subjected to stress, and **creepage distances** and **clearances** are not reduced below the values specified in 28.1.

Compliance is checked by inspection, and by the test of 9.6 of IEC 60999-1:1999, the torque applied being, however, equal to two-thirds of the torque specified in Table 4 of that standard.

Terminals may be prevented from working loose by fixing with two screws, by fixing with one screw in a recess, so that there is no appreciable play, or by other suitable means.

*The requirement for fixation of terminals does not preclude the provision of supply terminals on switches, or similar device in a recess if, after connection of the **supply cord**, and after re-positioning of the switch or similar device in its recess, it can be verified by inspection that these components and the **supply cord** are, after reassembly of the tool, in the correct position.*

*Covering with sealing compound without other means of locking is not considered to be sufficient. Self-hardening resins may, however, be used to lock terminals which are not subject to torsion in **normal use**.*

25.4 For tools with **type X attachment**, terminals shall be so designed that they clamp the conductor between metal surfaces with sufficient contact pressure, and without damage to the conductor.

Compliance is checked by inspection of the terminals and of the conductors after the test of 25.3.

25.5 Terminals of the pillar type shall be so constructed and located that the end of a conductor introduced into the hole is visible, or can pass beyond the threaded hole for a distance at least equal to half the nominal diameter of the screw but at least 2,5 mm.

Compliance is checked by inspection and by measurement.

25.6 For **type X attachment**, the terminals shall be clearly recognizable and accessible after opening the tool. All terminals shall be located behind one cover, or one part of the enclosure.

Compliance is checked by inspection.

25.7 Terminal devices of tools with **type X attachment** shall be so located or shielded that should a wire of a stranded conductor escape when the conductors are fitted, there is no risk of accidental connection between **live parts** and accessible metal parts and, in the case of **class II tools**, between **live parts** and metal parts separated from accessible metal parts by **supplementary insulation** only.

Compliance is checked by the following test.

An 8 mm length of insulation is removed from the end of a flexible conductor having a nominal cross-sectional area as specified in 24.5.

One wire of the stranded conductor is left free, and the other wires are fully inserted into and clamped in the terminal.

The free wire is bent, without tearing the insulation back, in every possible direction, but without making sharp bends around barriers.

*The free wire of a conductor connected to a live terminal shall not touch any metal part which is accessible, or is connected to an accessible metal part or, for **class II tools**, any metal part which is separated from **accessible parts** by **supplementary insulation** only. The free wire of a conductor connected to an earthing terminal shall not touch any **live part**.*

26 Provision for earthing

26.1 Accessible parts of **class I tools**, which may become live in the event of an insulation fault, shall be permanently and reliably connected to an earthing terminal or termination within the tool, or to the earthing contact of the tool inlet.

The printed conductors of printed circuit boards shall not be used to provide continuity of the protective earthing circuit.

Earthing terminals and earthing contacts shall not be electrically connected to the neutral terminal.

Class II tools and **class III tools** shall have no provision for earthing.

If accessible metal parts are screened from **live parts** by metal parts which are connected to the earthing terminal or termination, or to the earthing contact, they are not, for the purpose of this requirement, regarded as likely to become live in the event of an insulation fault.

Rotating motor components that have metal-to-metal bearing surfaces shall be considered to be electrically bonded to each other through the bearing surfaces for earthing purposes.

Accessible parts, which are separated from **live parts** by **double insulation** or by **reinforced insulation**, are not considered likely to become live in the event of an insulation fault.

Metal parts behind a decorative cover which does not withstand the test of Clause 20 are considered to be **accessible parts**.

Compliance is checked by inspection.

26.2 The clamping means of earthing terminals shall be adequately locked against accidental loosening, and it shall not be possible to loosen them without the aid of a tool. Screw clamping terminals complying with Clause 25 or screwless terminals in accordance with IEC 60998-2-2 are considered to comply with the requirements of 26.2.

For specifically prepared cords, terminals complying with IEC 61210 and the specifications in Table 10 are considered to comply with the requirements of 26.2. The connector material of quick connect terminals, if steel, shall comply with the requirements of Clause 15.

Table 10 – Quick-connect terminals for earthing conductors

Nominal cross-sectional area mm ²	AWG wire size	Minimum tab width mm	Minimum tab thickness mm	Connector material
0,75 to 1,0	18	2.8	0.5	Brass or steel
1,5	16	2.8	0.8	Brass or steel
1,5	16	2.8	0.5	Brass
2,5	14	6.35	0.8	Brass or steel

Compliance is checked by inspection, by measurement, by manual test and, for screwless terminals, by the tests specified in IEC 60998-2-2.

26.3 If **detachable parts** have an earth connection, this connection shall be made before the current-carrying connections are established when placing the part in position, and the current-carrying connections shall be separated before the earth connection is broken when removing the part.

For tools with **supply cords**, the arrangement of the terminals, or the length of the conductors between the cord anchorage and the terminals, shall be such that the current-carrying conductors become taut before the earthing conductor, if the cord slips out of the cord anchorage.

Compliance is checked by inspection and by manual test.

26.4 All parts of the earthing terminal intended for the connection of external conductors shall be such that there is no risk of corrosion resulting from contact between these parts and the copper of the earthing conductor, or any other metal in contact with these parts.

Parts which may transmit current in the event of an insulation fault, other than parts of a metal frame or enclosure, shall be of coated or uncoated metal having adequate resistance to corrosion. If such parts are of steel, they shall be provided at the essential areas with an electroplated coating having a thickness of at least 5 µm.

Parts of coated or uncoated metal, which are only intended to provide or to transmit contact pressure, shall be adequately protected against rusting.

If the body of the earthing terminal is a part of a frame or enclosure of aluminium or aluminium alloy, precautions shall be taken to avoid the risk of corrosion resulting from contact between copper and aluminium or its alloys.

Parts of copper alloys containing at least 58 % copper for parts that are worked cold, and at least 50 % copper for other parts, and parts of stainless steel containing at least 13 % chrome, are considered to be sufficiently resistant to corrosion. Parts subjected to a treatment such as chromate conversion coating are in general not considered to be adequately protected against corrosion, but they may be used to provide or to transmit contact pressure.

The essential areas of steel parts are, in particular, those transmitting current. In evaluating such areas, the thickness of the coating in relation to the shape of the part has to be taken into account. In case of doubt, the thickness of the coating is measured as described in ISO 2178 or in ISO 1463.

Compliance is checked by inspection, by measurement, by manual test, and by the test of 15.1.

26.5 The connection between the earthing terminal or earthing contact, and earthed metal parts shall be of low resistance.

Compliance is checked by the following test.

*A current derived from a source having a no-load voltage not exceeding 12 V (a.c. or d.c.) and equal to 1,5 times **rated current** of the tool, or 25 A, whichever is the greater, is passed between the earthing terminal or earthing contact, and each of the accessible metal parts in turn.*

The voltage drop between the earthing terminal of the tool or the earthing contact of the tool inlet, and the accessible metal part is measured, and the resistance calculated from the current and this voltage drop.

In no case shall the resistance exceed 0,1 Ω .

In case of doubt, the test is carried out until steady conditions have been established.

The resistance of the flexible cord is not included in the resistance measurement.

Care is taken that the contact resistance between the tip of the measuring probe and the metal part under test does not influence the test results.

27 Screws and connections

27.1 Fixings, and electrical connections, the failure of which may impair compliance with this standard, and connections providing earthing continuity shall withstand mechanical stresses occurring.

Screws used for this purpose shall not be of metal which is soft or liable to creep, such as zinc or aluminium.

Such screws, when of insulating material, shall have a nominal diameter of at least 3 mm; they shall not be used for any electrical connection or connections providing earthing continuity.

Screws transmitting electrical contact pressure shall screw into metal.

Screws shall not be of insulating material if their replacement by a metal screw could impair **supplementary insulation** or **reinforced insulation**.

Screws which may be removed when replacing a **supply cord** having a **type X attachment**, or when undertaking **user maintenance**, shall not be of insulating material if their replacement by a metal screw could impair **basic insulation**.

Compliance is checked by inspection and by the following test.

Screws and nuts are tested if they are

– used for electrical connections;

- used for connections providing earthing continuity;
- likely to be tightened
 - during user maintenance;
 - when replacing a **supply cord having a type X attachment**;
 - during installation/assembly in accordance with the information required in 8.14.2 a).

The screws or nuts are tightened and loosened without jerking:

- 10 times for screws in engagement with a thread of insulating material;
- 5 times for nuts and other screws.

Screws in engagement with a thread of insulating material are completely removed and reinserted each time.

When testing terminal screws and nuts, a conductor of the nominal cross-sectional area specified in 24.5 is placed in the terminal. It is repositioned before each tightening.

The test is carried out by means of a suitable test screwdriver, spanner or key and by applying a torque as shown in Table 11. The shape of the blade of the test screwdriver is to fit the head of the screw to be tested. The appropriate column being:

Column I is applicable for metal screws without heads if the screw does not protrude from the hole when tightened.

Column II is applicable

- for other metal screws and for nuts;
- for screws of insulating material
 - having a hexagonal head with the dimension across flats exceeding the overall thread diameter, or
 - with a cylindrical head and a socket for a key, the socket having a cross-corner dimension exceeding the overall thread diameter, or
 - with a head having a slot or cross-slots, the length of which exceeds 1,5 times the overall thread diameter.

Column III is applicable for other screws of insulating material.

During the test, no damage impairing the further use of the fixing or electrical connections shall occur.

Table 11 – Torque for testing screws and nuts

Nominal diameter of screw mm	Torque Nm		
	I	II	III
Up to and including 2,8	0,2	0,4	0,4
Over 2,8 up to and including 3,0	0,25	0,5	0,5
Over 3,0 up to and including 3,2	0,3	0,6	0,5
Over 3,2 up to and including 3,6	0,4	0,8	0,6
Over 3,6 up to and including 4,1	0,7	1,2	0,6
Over 4,1 up to and including 4,7	0,8	1,8	0,9
Over 4,7 up to and including 5,3	0,8	2,0	1,0
Over 5,3	–	2,5	1,25

27.2 Electrical connections shall be so designed that contact pressure is not transmitted through insulating material which is liable to shrink or to distort, unless there is sufficient resiliency in the metallic parts to compensate for any possible shrinkage or distortion of the insulating material. Ceramic material is not liable to shrink or to distort.

Compliance is checked by inspection.

27.3 Space-threaded (sheet metal) screws shall not be used for the connection of current-carrying parts, unless they clamp these parts directly in contact with each other, and are provided with a suitable means of locking.

Thread-cutting (self-tapping) screws shall not be used for the electrical connection of current-carrying parts, unless they generate a full-form standard machine screw thread. Such screws shall not, however, be used if they are likely to be operated by the user, unless the thread is formed by a swageing action.

Thread-cutting and space-threaded screws may be used to provide earthing continuity, provided that it is not necessary to disturb the connection in **normal use**, and that at least two screws are used for each connection.

Compliance is checked by inspection.

27.4 Screws, which make a mechanical connection between different parts of the tool, shall be secured against loosening, if they also make electrical connections.

This requirement does not apply to screws in the earthing circuit if at least two screws are used for the connection, or if an alternative earthing circuit is provided.

Spring washers and the like may provide satisfactory security. Sealing compound which softens on heating provides satisfactory security only for screw connections not subject to torsion in **normal use**.

Rivets used for electrical connections shall be secured against loosening if these connections are subject to torsion in **normal use**. A non-circular shank or an appropriate notch may be sufficient to comply with this requirement.

This requirement does not imply that more than one rivet is necessary for providing earthing continuity.

Compliance is checked by inspection and by manual test.

27.5 Screwless connectors, not intended for disconnection in **normal use**, shall prevent disconnection in **normal use**.

Compliance is checked by the following test.

Connectors that terminate a wire shall withstand a pull of 5 N applied through the wire in the opposite direction from the force used to apply the connector. Neither the connector nor the wire shall become disconnected. In the case where the direction of the application is not in line with the exit direction of the wire, then the force shall be applied in both directions, one at a time.

Connectors investigated to their relevant IEC standards (IEC 61210, IEC 60998-2-1, IEC 60998-2-2, IEC 60999-1:1999, IEC 61984) for retention, are considered to have met the requirements of 27.5.

27.5.1 Conductors shall be secured by more than one means or shall not impair safety in the event of detachment.

Compliance is checked by inspection and, if applicable, by the following test.

If there is only one means of securing, the conductors are detached from their connector one at a time and subjected to the following.

*The detached conductor is moved around its nearest point of retention to check that **clearances** cannot be reduced to less than 50 % of the values specified in 28.1.*

NOTE Examples of more than one means of securing conductors include connectors that are designed to crimp both the insulation and the inner conductor of the wire.

28 Creepage distances, clearances and distances through insulation

28.1 Creepage distances and clearances shall not be less than the values in millimetres shown in Table 12. The values specified in the table do not apply to cross-over points of motor windings.

The values in Table 12 are equal or larger than the values required by IEC 60664-1, when

- an overvoltage category II;
- a material group III;
- a pollution degree 1 for parts protected against deposition of dirt and for lacquered or enamelled windings;
- a pollution degree 3 for other parts;
- inhomogeneous electric field

are applied.

If a resonance voltage occurs between the point where a winding and a capacitor are connected together, and metal parts which are separated from **live parts** by **basic insulation** only, the **creepage distance** and **clearance** shall not be less than the values specified for the value of the voltage imposed by the resonance, these values being increased by 4 mm in the case of **reinforced insulation**.

Compliance is checked by measurement.

For tools provided with an appliance inlet, the measurements are made with an appropriate connector inserted. For other tools, they are made on the tool as delivered.

For tools provided with belts, the measurements are made with the belts in place, and the devices intended for varying the belt tension adjusted to the most unfavourable position within their range of adjustment, and also with the belts removed.

Movable parts are placed in the most unfavourable position; nuts and screws with non-circular heads are assumed to be tightened in the most unfavourable position.

*The **clearances** between terminals and accessible metal parts are also measured with the screws or nuts unscrewed as far as possible, but the **clearances** shall then be not less than 50 % of the value shown in Table 12.*

Table 12 – Minimum creepage distances and clearances

Dimensions in millimetres

Distances	Class III tools		Other tools					
			Working voltage ≤ 130 V		Working voltage > 130 V and ≤ 280 V		Working voltage > 280 V and ≤ 480 V	
	Creepage distance	Clearance	Creepage distance	Clearance	Creepage distance	Clearance	Creepage distance	Clearance
Between live parts of different polarity ^a : – if lacquered or enamelled windings or if protected against deposition of dirt ^b – if not protected against deposition of dirt	1,0	1,0	1,0	1,0	2,0	2,0	2,0	2,0
	2,0 ^d	1,5	2,0 ^c	1,5	3,0 ^c	2,5	8,0 ^d	3,0
Between live parts and other metal parts over basic insulation : – if the live parts are lacquered or enamelled windings ^e or if protected against deposition of dirt ^b – if not protected against deposition of dirt	–	–	1,0	1,0	2,0	2,0	– ^f	– ^f
	–	–	2,4 ^d	1,5	4,0 ^d	3,0	– ^f	– ^f
Between live parts and other metal parts over reinforced insulation : – if the live parts are lacquered or enamelled windings or protected against deposition of dirt ^b – for other live parts not protected against deposition of dirt	–	–	5,0	5,0	6,0	6,0	– ^f	– ^f
	–	–	5,0	5,0	8,0	8,0	– ^f	– ^f
Between metal parts separated by supplementary insulation	–	–	2,5	2,5	4,0	4,0	– ^f	– ^f

^a The **clearances** specified do not apply to the air gap between the contacts of thermal controls, overload protection devices, switches of micro-gap construction, and the like, or to the air gap between the current-carrying members of such devices where the **clearance** varies with the movement of the contacts.

^b In general, the interior of a tool having a reasonably dust-proof enclosure is considered to be protected against deposition of dirt, provided the tool does not generate dust within itself; hermetic sealing is not required.

^c These **creepage distances** are slightly lower than suggested by IEC 60664-1. **Creepage distances** between **live parts** of different polarity (functional insulation) are only associated to fire hazard, not to electric shock hazard. As products in the scope of IEC 62841 are products supervised during **normal use**, lower distances are justified.

^d These **creepage distances** may be reduced to values in accordance with IEC 60664-1, if the insulation parts are of material group II or lower.

^e Windings are considered to have **basic insulation** if they are wrapped with tape and then impregnated, or if they are covered with a layer of self-hardening resin, and if, after the test of 14.1, an electric strength test as specified in Clause D.2 is withstood, the test voltage being applied between the conductors of the winding and metal foil in contact with the surface of the insulation.

It is sufficient that the wrapping and impregnation, or the layer of self-hardening resin, cover the windings only at places where it is not possible to obtain the **creepage distance** or **clearance** specified for lacquered or enamelled windings.

^f The **rated voltage** between a three-phase supply and earth will not be more than 277 V, therefore the column "**Working voltage** > 130 V and ≤ 280 V" will apply. For **working voltages** greater than 280 V, **creepage distances** and **clearances** shall be determined in accordance with IEC 60664-1, but shall not be lower than the values required in the column "**Working voltage** > 130 V and ≤ 280 V".

Distances through slots or openings in external parts of insulating material are measured to metal foil in contact with the accessible surface; the foil is pushed into corners and the like by means of the test probe B of IEC 61032:1997, but it is not pressed into openings.

*If necessary, a force is applied to any point on internal wiring and bare conductors, other than those of heating elements, to any point on uninsulated metal capillary tubes of **thermostats** and similar devices, and to the outside of metal enclosures, in an endeavour to reduce the **creepage distances** and **clearances** while taking the measurements.*

The force is applied by means of the test probe B of IEC 61032:1997, and has a value of:

- 2 N for internal wiring and bare conductors and for uninsulated capillary tubes of **thermostats** and similar devices;
- 30 N for enclosures.

*The way in which **creepage distances** and **clearances** are measured is indicated in Annex A.*

*For tools having parts with **double insulation** where there is no metal between **basic insulation** and **supplementary insulation**, the measurements are made as though a metal foil were present between the two insulations.*

Means provided for fixing the tool to a support are considered to be accessible.

For conductive patterns on printed circuit boards, except at their edges, the values in the table between parts of different potential may be reduced, as long as the peak value of the voltage stress does not exceed:

- 150 V per mm with a minimum distance of 0,2 mm, if protected against the deposition of dirt;
- 100 V per mm with a minimum distance of 0,5 mm, if not protected against the deposition of dirt.

When the limits mentioned above lead to higher values than those of the table, the values of the table apply.

NOTE The above values are equal or larger than the values required by IEC 60664-3.

These distances may be reduced further, provided that the tool complies with the requirements of Clause 18 when the distances are short-circuited in turn.

***Creepage distances** and **clearances** within optocouplers are not measured if the individual insulations are adequately sealed, and if air is excluded between individual layers of the material.*

*For **live parts** of different polarity, except for external mains connection, **creepage distances** and **clearances** smaller than those specified in the table are allowed, provided the requirements of Clause 18 are met if these **creepage distances** and **clearances** are short-circuited in turn.*

28.2 Depending on the **working voltage**, the distance through insulation shall be sufficient:

- For **working voltages** up to and including 130 V, the distance through insulation between metal parts shall not be less than 1,0 mm, if they are separated by **supplementary insulation**, and not be less than 1,5 mm, if they are separated by **reinforced insulation**.
- For **working voltages** over 130 V up to and including 280 V, the distance through insulation between metal parts shall not be less than 1,0 mm, if they are separated by **supplementary insulation**, and not be less than 2,0 mm, if they are separated by **reinforced insulation**.

- For **working voltages** up to and including 280 V, the distance through **reinforced insulation** used between windings and accessible metal shall not be less than 1,0 mm.

The required distance through insulation may be achieved through several thicknesses of solid insulation layers that may have intervening air between the layers such that the sum of the thicknesses of the solid insulation equals the required thickness.

This requirement does not apply, if either a) or b) is fulfilled.

- a) The insulation is applied in thin sheet form, other than mica or similar scaly material, and consists:
 - for **supplementary insulation**, of at least two layers, provided that any one of the layers withstands the electric strength test prescribed for **supplementary insulation**;
 - for **reinforced insulation**, of at least three layers, provided that, when any two of the layers are placed in contact, they withstand the electric strength test prescribed for **reinforced insulation**.

The test voltage is applied between the outer surfaces of the layer, or of the two layers, as applicable.

- b) The **supplementary insulation** or the **reinforced insulation** is inaccessible and meets the following condition:

The insulation, after having been conditioned for seven days (168 h) in an oven maintained at a temperature equal to 50 K greater than the maximum temperature rise determined during the test of Clause 12 withstands an electric strength test as specified in Annex D, this test being made on the insulation both at the temperature occurring in the oven, and at approximately room temperature.

Compliance is checked by inspection and by measurement.

For optocouplers, the conditioning procedure is carried out at a temperature of 50 K in excess of the maximum temperature rise measured on the optocoupler during the tests of Clause 12 and Clause 18, the optocoupler being operated under the most onerous conditions which occur during these tests.

Dimensions in millimetres

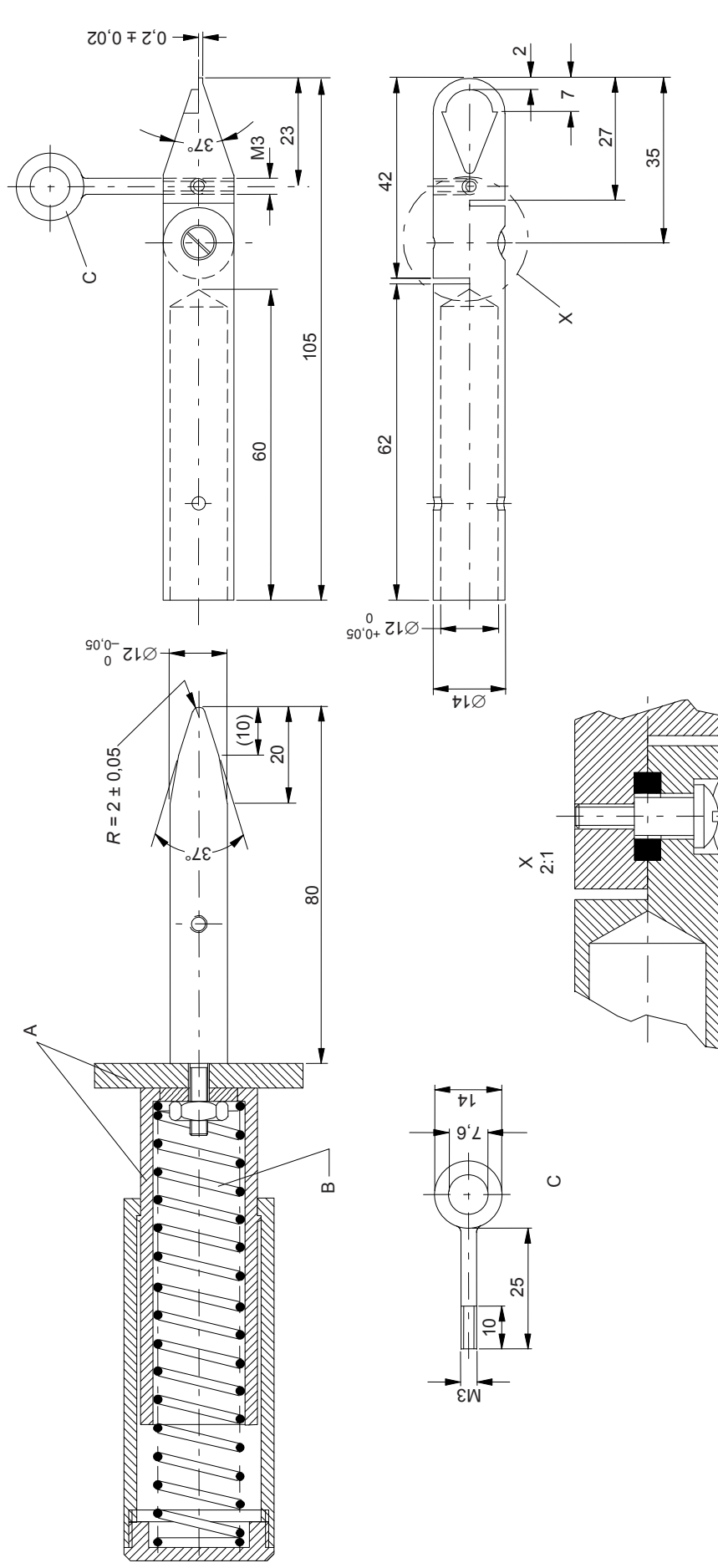

IEC 987/10

Key

- A insulating material
- B spring diameter
- C loop

Figure 1 – Test fingernail

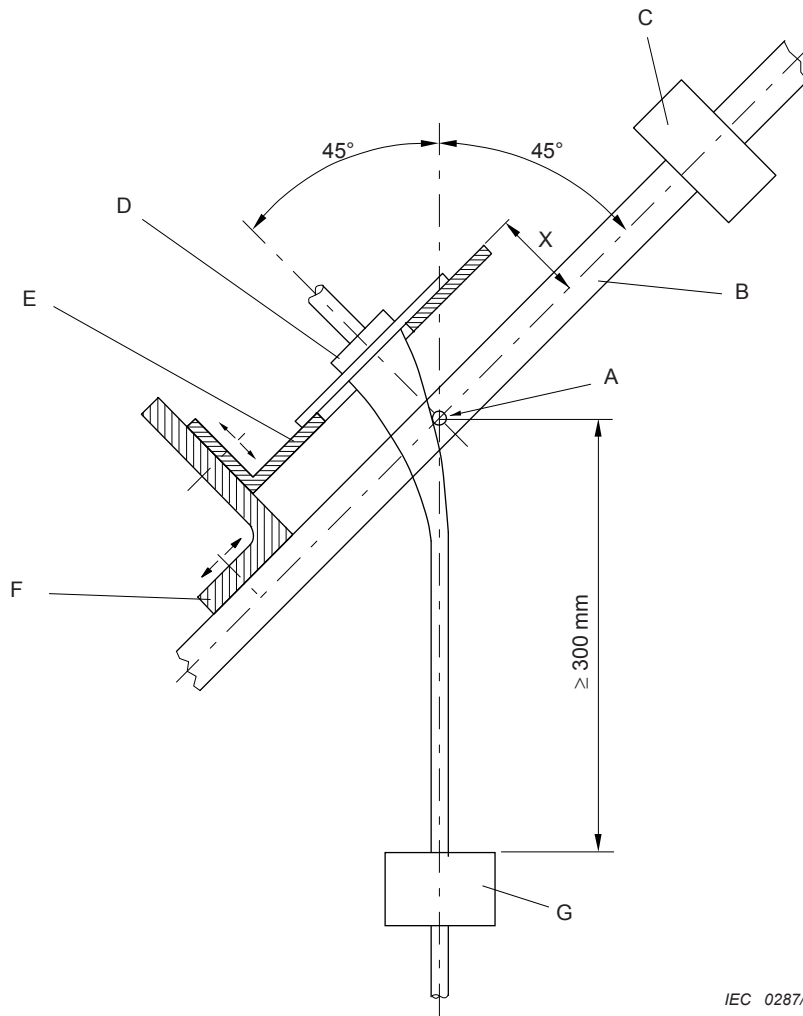

IEC 0287/14

Key

- A axis of oscillation
- B oscillating frame
- C counterweight
- D sample
- E adjustable carrier plate
- F adjustable bracket
- G load

Figure 2 – Flexing test apparatus

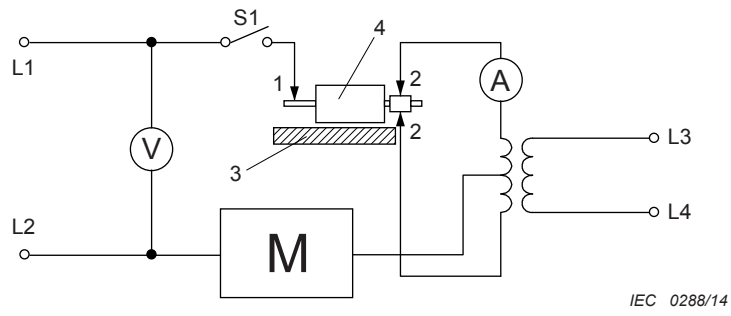

Key

- 1 shaft contact
- 2 commutator contacts
- 3 insulating table
- 4 armature
- L1, L2 voltage supply for leakage current measurement
- L3, L4 voltage supply (variable) for armature load current
- M circuit of Figure C.3 for the leakage current meter

Figure 3 – Overload test of a class II armature

Annex A (normative)

Measurement of creepage distances and clearances

The methods of measuring **creepage distances** and **clearances**, which are specified in 28.1, are indicated in cases 1 to 10 (see Figures A.1 to A.4).

These cases do not differentiate between gaps and grooves, or between types of insulation.

The following assumptions are made:

- *a groove may have parallel, converging, or diverging sides;*
- *any groove having diverging sides, a minimum width exceeding 0,25 mm, a depth exceeding 1,5 mm, and a width at the bottom equal to or greater than 1 mm, is regarded as an air gap across which no creepage path exists (case 8);*
- *any corner including an angle less than 80° is assumed to be bridged with an insulating link of 1 mm width (0,25 mm for dirt-free situations), moved into the most unfavourable position (case 3);*
- *where the distance over the top of a groove is 1 mm (0,25 mm for dirt-free situations) or more, no **creepage distance** exists across the air gap (case 2);*
- ***creepage distances** and **clearances** measured between parts moving relative to each other are measured when these parts are placed in their most unfavourable stationary positions;*
- *any air gap less than 1 mm wide (0,25 mm for dirt-free situations) is ignored in computing the total **clearance**.*

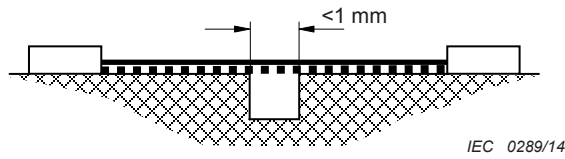

Condition: Path under consideration includes a parallel or converging sided groove of any depth with a width less than 1 mm.

Rule: **Creepage distance** and **clearance** are measured directly across the groove as shown.

Case 1

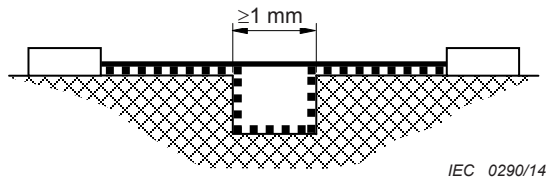

Condition: Path under consideration includes a parallel sided groove of any depth equal to or more than 1 mm wide.

Rule: **Clearance** is the "line of sight" distance. Creepage path follows the contour of the groove.

Case 2

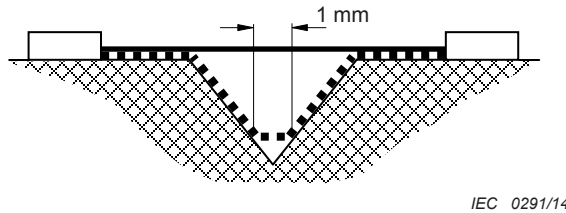

Condition: Path under consideration includes a V-shaped groove with internal angle of less than 80° and with a width greater than 1 mm.

Rule: **Clearance** is the "line of sight" distance. Creepage path follows the contour of the groove but "short circuits" the bottom of the groove by 1 mm link (0,25 mm for dirt-free situations).

Case 3

————— Clearance ■■■■■■ Creepage distance

Figure A.1 – Clearance gap for parallel sided and V-shaped groove

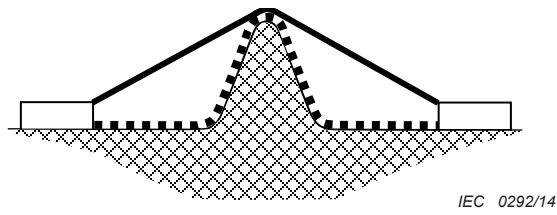

Condition: Path under consideration includes a rib.

Rule: **Clearance** is the shortest direct path over the top of the rib. Creepage path follows the contour of the rib.

Case 4

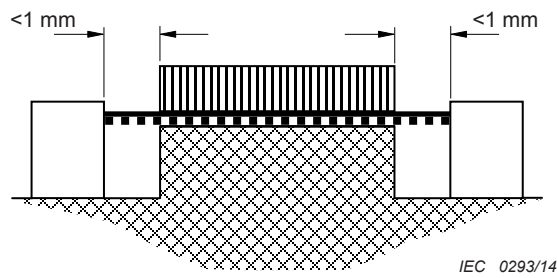

Condition: Path under consideration includes an uncemented joint with grooves less than 1 mm wide on either side (0,25 mm for dirt-free situations).

Rule: **Creepage distance** and **clearance** is the "line of sight" distance shown.

Case 5

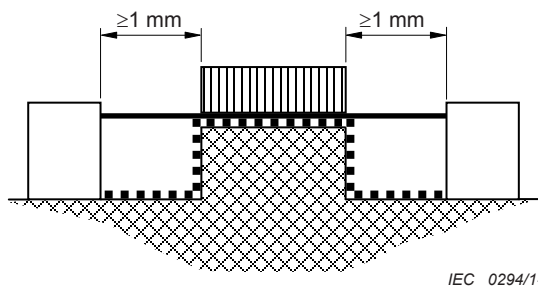

Condition: Path under consideration includes an uncemented joint with grooves equal to or more than 1 mm wide each side.

Rule: **Clearance** is the "line of sight" distance. Creepage path follows the contour of the grooves.

Case 6

Clearance
 Creepage distance

Figure A.2 – Clearance gap for rib and uncemented joint with groove

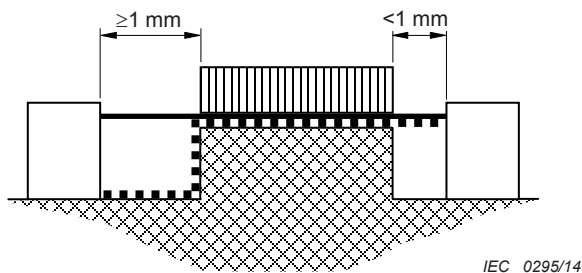

Condition: Path under consideration includes an uncemented joint with a groove on one side less than 1 mm wide and the groove on the other side equal to or more than 1 mm wide.

Rule: **Clearance** and creepage path are as shown.

Case 7

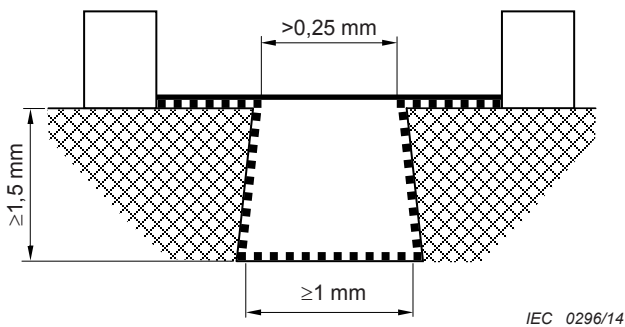

Condition: Path under consideration includes a diverging-sided groove equal to or greater than 1,5 mm deep and greater than 0,25 mm wide at the narrowest part and equal to or greater than 1 mm at the bottom.

Rule: **Clearance** is the "line of sight" distance. Creepage path follows the contour of the groove.

Case 3 also applies to the internal corners if they are less than 80°.

Case 8

————— Clearance ■■■■■■ Creepage distance

Figure A.3 – Clearance gap for uncemented joint and diverging-sided groove

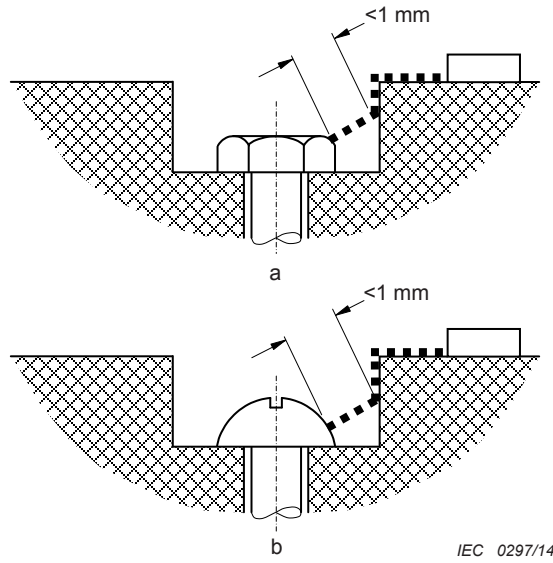

Gap between head of screw and wall of recess too narrow to be taken into account.

Case 9

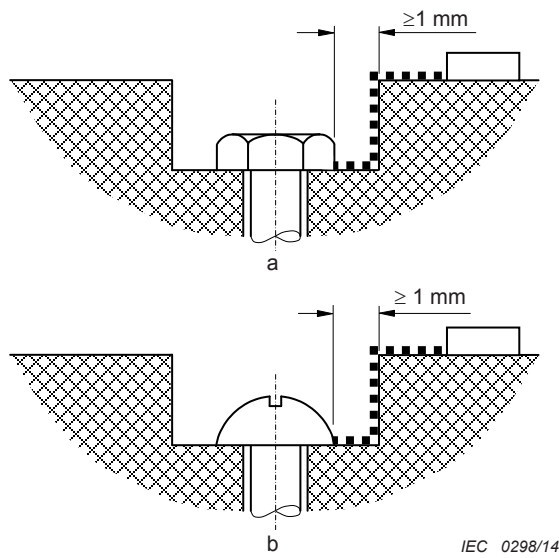

Gap between head of screw and wall of recess wide enough to be taken into account.

Case 10

————— Clearance ■■■■■■■ Creepage distance

Figure A.4 – Clearance gap between wall and screw

Annex B (normative)

Motors not isolated from the supply mains and having basic insulation not designed for the rated voltage of the tool

B.1 Scope

B.1.1 This annex applies to motors having a **working voltage** not exceeding a peak value of 42,4 V, not isolated from the supply mains, and having **basic insulation** not designed for the **rated voltage** of the tool.

All clauses of this standard apply to these motors, unless otherwise specified in this annex.

B.9 Protection against access to live parts

B.9.2

Metal parts of the motor are considered to be bare **live parts**.

B.12 Heating

B.12.4 *The temperature rise of the body of the motor is determined instead of the temperature rise of the windings.*

B.12.5 *The temperature rise of the body of the motor, where it is in contact with insulating material, shall not exceed the values shown in Table 1 for the relevant insulating material.*

B.18 Abnormal operation

B.18.1 The test of 18.3 is not made.

Tools are also subjected to the test of B.18.201.

B.18.201 *The tool is operated at **rated voltage** with each of the following fault conditions (see Figure B.1):*

- *short circuit of the terminals of the motor, including any capacitor incorporated in the motor circuit;*
- *open circuit of the supply to the motor;*
- *open circuit of any shunt resistor during operation of the motor.*

Only one fault condition is simulated at a time, the tests being made consecutively.

B.21 Construction

B.21.201 For **class I tools** incorporating a motor supplied by a rectifier circuit, the d.c. circuit shall be insulated from **accessible parts** of the tool by **double insulation** or **reinforced insulation**.

Compliance is checked by the tests specified for **double insulation** and **reinforced insulation**.

B.28 Creepage distances, clearances and distances through insulation

B.28.1

The values specified in Table 12 do not apply to distances between **live parts** of the motor and its other metal parts.

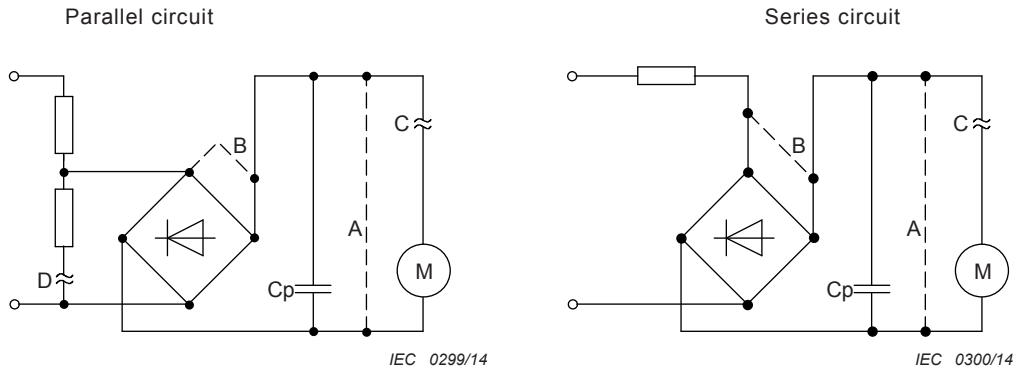

Key

- original connection
- - - short circuit
- ≈ open circuit
- A short circuit of the terminals of the motor
- B short circuit of the terminals of the rectifier
- C open circuit of the supply to the motor
- D open circuit of the shunt resistor

Figure B.1 – Simulation of fault conditions

Annex C (normative)

Leakage current

C.1 General

For battery-operated tools in accordance with Annex L, this annex only applies when the tool is in the configuration where it is directly connected to the mains or to a non-isolated source.

The leakage current, when required by other clauses, shall be measured by the following test under one of the conditions of Clause C.2 or Clause C.3, both with the tool switch S in the closed position.

The leakage current test is made with a.c. unless the tool is for d.c. only, in which case the test is not made.

Protective impedance is disconnected from **live parts** before carrying out the tests.

It is recommended that the tool be supplied through an isolating transformer; otherwise, it shall be insulated from earth.

The leakage current (weighted touch current) is measured by means of the circuit of Figure C.3 between any pole of the supply and accessible metal parts and metal foil in contact with accessible surfaces of insulating material, connected together.

NOTE The weighted touch current is equivalent to MIU (Measurement Indication Units).

The measurement circuit of Figure C.3 shall meet the accuracy specifications in Clause G.3 of IEC 60990:1999.

If the leakage current exceeds the specified limit due to capacitance effects, then metal foil with an area not exceeding 20 cm × 10 cm shall be used. If its area is smaller than the surface under test, it is moved to make sure all parts of the surface are tested. The heat dissipation of the tool shall, however, not be affected by the metal foil in areas such as ventilation openings.

The leakage current to accessible metal parts and metal foil shall not exceed the following values, unless otherwise specified in the relevant clause of this standard:

- for **class I tools** 0,75 mA;
- for **class II tools** 0,25 mA.

C.2 Measurement of a non-operating tool

*The tool is not operated and the test is made at **rated voltage** unless otherwise specified in the relevant clause of this standard, under the conditions defined in Clause C.1 and as follows:*

For single-phase tools and for three-phase tools, which are, according to the instructions for installation, suitable for single-phase supply:

S1 of Figure C.1 in the open position, for three-phase tools with the three sections connected in parallel. The selector switch shown in Figure C.1 may be in any of the positions 1 and 2.

For three-phase tools not suitable for single-phase supply:

a in Figure C.2 in the closed position, b and c in open position.

C.3 Measurement of an operating tool

The tool is operated and the test is made at **rated voltage** unless otherwise specified in the relevant clause of this standard, under the conditions defined in Clause C.1 and is measured within 10 s when tested as follows:

For single-phase tools and for three-phase tools, which are, according to the instructions for installation, suitable for single-phase supply:

S1 of Figure C.1 in the closed position and with the selector switch shown in Figure C.1 in each of the positions 1 and 2, for three-phase tools with the three sections connected in parallel.

For three-phase tools not suitable for single-phase supply:

a, b and c in Figure C.2 in the closed position, repeated with each of the switches a, b, c open in turn, the other two switches being closed.

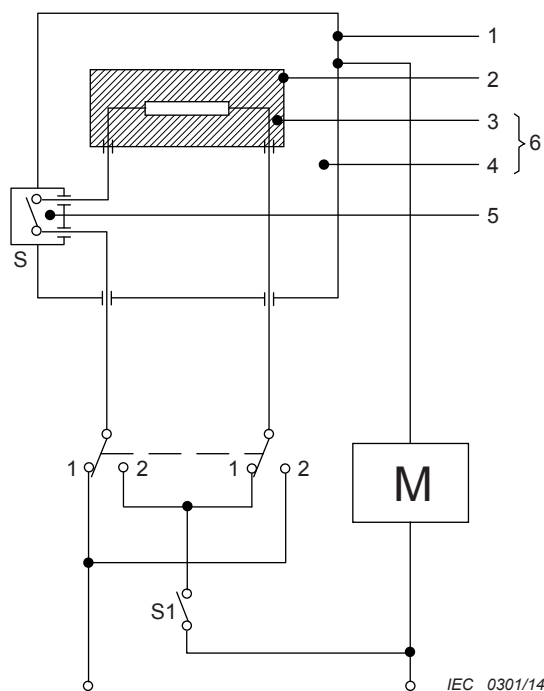

Key

- M circuit of Figure C.3 for the leakage current meter
- S **power switch** of the product under test
- 1 **accessible part**
- 2 **inaccessible metal part**
- 3 **basic insulation**
- 4 **supplementary insulation**
- 5 **reinforced insulation**
- 6 **double insulation**

Figure C.1 – Diagram for leakage current measurement for single-phase connection and three-phase tools suitable for single-phase supply

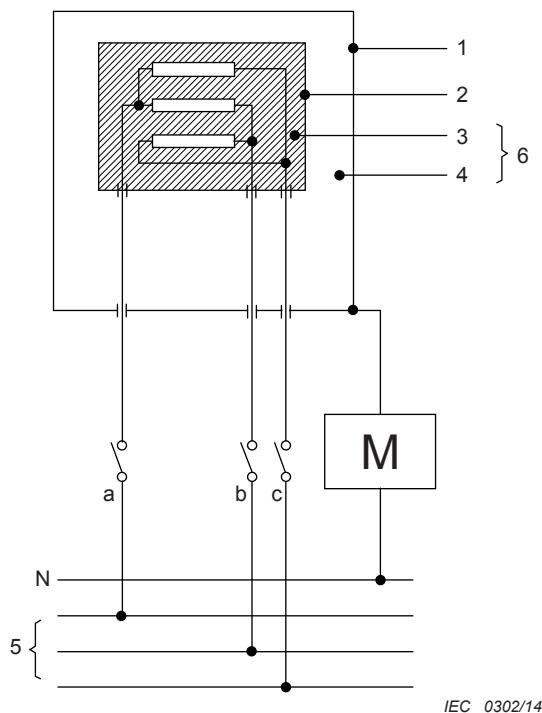

Key

- M circuit of Figure C.3 for the leakage current meter
- 1 **accessible part**
- 2 inaccessible metal part
- 3 **basic insulation**
- 4 **supplementary insulation**
- 5 three-phase supply
- 6 **double insulation**

Figure C.2 – Diagram for leakage current measurement for three-phase connection

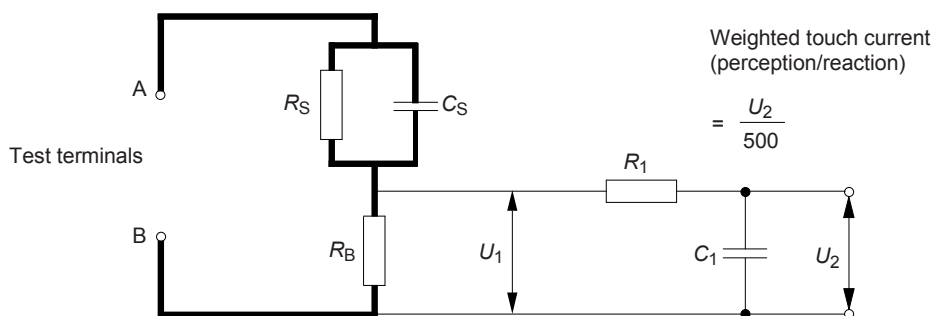

IEC 0303/14

R_S	1 500 Ω	R_1	10 000 Ω
R_B	500 Ω	C_1	0,022 μF
C_S	0,22 μF		

Figure C.3 – Circuit of the leakage current meter

Annex D (normative)

Electric strength

D.1 General

*Protective impedance is disconnected from **live parts** before carrying out the tests.*

The tests are made on the tools not connected to the supply.

The electric strength is checked by the tests of Clause D.2.

*For **class II construction** incorporating both **reinforced insulation** and **double insulation**, care is taken that the voltage applied to the **reinforced insulation** does not overstress the **basic insulation**, or the **supplementary insulation**.*

***Basic insulation** and **supplementary insulation** may be tested separately or in combination. When tested in combination the test voltage shall be as specified for **reinforced insulation**. If either the basic or **supplementary insulation** is overstressed during the combination test, each insulation is tested separately. Insulation of components that cannot be tested in combination shall be tested separately.*

For tools with heating elements incorporated, the test voltages specified in IEC 60335-1:2010 apply to the heating elements only and not to other parts of the tool.

*For motors in accordance with Annex B, the insulation between **live parts** of the motor and its other metal parts is not subjected to this test.*

For tools in accordance with Annex L, the test only applies when the tool is in the configuration where it is directly connected to the mains or to a non-isolated source. Care shall be taken that the premature failure of electronic devices does not prevent the application of the test voltage across insulation. If this is the case, electronic devices may be bypassed to enable the test to be conducted.

D.2 Electric strength test

The insulation is subjected for 1 min to a voltage of substantially sinusoidal waveform, having a frequency of 50 Hz or 60 Hz. The values of the test voltage in accordance with the type of insulation are shown in Table D.1.

***Accessible parts** of insulated material are covered with metal foil.*

Table D.1 – Test voltages

Insulation	Test voltage V
Basic insulation	1 250
Supplementary insulation	2 500
Reinforced insulation	3 750

To distinguish between capacitor reactance current and unacceptable performance, a d.c. potential of 1,414 times the values specified for a.c. may be substituted.

Initially, not more than half the prescribed voltage is applied, then the voltage is gradually raised over a period of up to 5 s to the full value.

No flashover or breakdown shall occur during the test.

The high-voltage source shall be capable of maintaining the specified voltage up to a current of at least 25 mA. The tripping current to detect a breakdown shall not be higher than 20 mA.

Care is taken that the r.m.s. value of the test voltage applied is measured within ± 3 %.

Care is taken that the metal foil is so placed that no flashover occurs at its edges or the edges of the insulation.

When testing insulating coatings, the metal foil may be pressed against the insulation by means of a sandbag of such a size that the pressure is about 5 kPa (0,5 N/cm²). The test may be limited to places where the insulation is likely to be weak, for example where there are sharp metal edges under the insulation.

Ⓢ Annex E

Void Ⓢ

Annex F (informative)

Rules for routine tests

F.1 General

The tests specified in this annex are intended to reveal, as far as safety is concerned, unacceptable variations in material or manufacture. These production tests do not impair the properties and the reliability of the tool, and should be made by the manufacturer on each tool.

In general, more tests, such as repetition of type tests and sampling tests, have to be made by the manufacturer to ensure that every tool conforms with the samples that withstood the tests of this specification, according to the experience gained by the manufacturer.

The manufacturer may use a test procedure which is better suited to his production arrangements and may make the tests at an appropriate stage during production provided it can be shown that tools which withstand the tests carried out by the manufacturer provide at least the same degree of safety as tools which withstand the tests specified in this annex.

F.2 Correct operation test

The safe operation shall be checked, for example, by electrical measurements, by verifying the functional devices, such as switches and manually-operated controls, and by verifying the direction of rotation of motors.

F.3 Electric strength test

The insulation of the tools shall be checked by the following test.

*A voltage of substantially sine-wave form, having a frequency of 50 Hz or 60 Hz and minimum the value shown in Table F.1, is immediately applied, for 3 s, or for 1 s with the voltage increased by 20 %, between **live parts** and:*

- a) *accessible metal parts which may become live in the event of an insulation fault or as a result of incorrect assembly;*
- b) *inaccessible metal parts.*

The tests of item a) are made on the assembled tool; the test of item b) is made on the tool, either completely assembled, or in the production line.

*The tests of item a) are made on all tools, the tests of item b) being only made on **class II tools**.*

The high-voltage source shall be capable of maintaining the specified voltage up to a current of at least 10 mA.

The overcurrent relay shall trip when the output current exceeds 5 mA.

Care shall be taken that the r.m.s. value of the test voltage applied is measured within $\pm 3\%$ and that the voltage measuring device or other indicator responds to the output voltage of the high-voltage source.

Attention is drawn to the fact that the test described cannot always be used if the tool incorporates d.c. components; in such cases, tests with d.c. may be necessary.

No flashover or breakdown current exceeding 5 mA shall occur during the tests.

Table F.1 – Test voltages for the electric strength test

Application of test voltage	Minimum test voltage V	
	Class II tools	Class I tools
Over basic insulation	1 000	1 000
Over double insulation or reinforced insulation	2 500	–

F.4 Earthing continuity test

For **class I tools**, a current of at least 10 A, derived from an a.c. source having a no-load voltage not exceeding 12 V, is passed between the earthing terminal or the earthing contact and, in turn, each of the accessible metal parts which need to be earthed for safety reasons.

The voltage drop between the earthing contact of the plug or the external end of an earth continuity conductor or of the appliance inlet and the accessible metal part is measured, and the resistance calculated from the current and this voltage drop.

In no case shall the resistance exceed 0,3 Ω. This value is applicable to **supply cord** lengths up to 5 m. In case of **supply cords** having a length exceeding 5 m it is increased by 0,12 Ω for any further length of 5 m.

Care shall be taken that the contact resistance between the tip of the measuring probe and the metal parts under test does not influence the test results.

Annex G

Void

Annex H (normative)

Determination of a low-power circuit

The determination if a circuit qualifies as a low-power circuit is as follows:

The tool is operated at **rated voltage**. A variable resistor, adjusted to its maximum resistance, is connected between the point to be investigated and the opposite pole of the supply source. The resistance is then decreased until the power consumed by the resistor reaches a maximum. Any point closest to the supply at which the maximum power delivered to this resistor does not exceed 15 W at the end of 5 s is called a low power point. The part of the circuit farther from the supply source than a low power point is considered to be a low-power circuit.

The measurements are made from only one pole of the supply source, preferably the one that gives the fewest low power points.

Circuit analysis may be used in lieu of testing to determine the highest power dissipation of circuits.

An example of a low-power circuit is shown in Figure H.1.

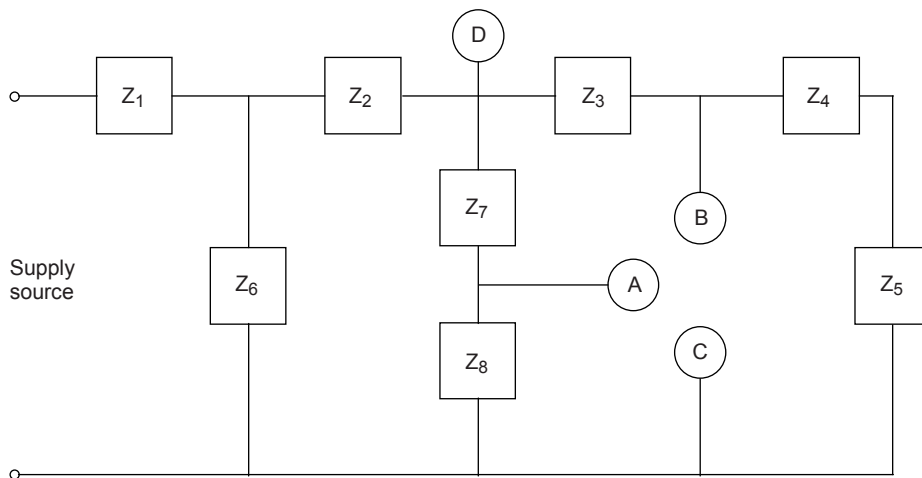

IEC 0304/14

When determining the low power points, it is recommended to start with the points close to the supply source.

A and B are points closest to the supply source where the maximum power delivered to external load does not exceed 15 W. These are low-power points.

D is a point farthest from the supply source where the maximum power delivered to external load exceeds 15 W.

Points A and B are separately short-circuited to C.

Figure H.1 – Example of an electronic circuit with low-power points

Annex I I (normative) I

Measurement of noise and vibration emissions

I.1 Scope

The requirements of this annex apply, if the declaration of noise or vibration emissions is required by national laws or if the manufacturer wishes to declare such emissions.

I.2 Noise test code (grade 2)

I.2.Z1 Noise reduction

Noise reduction at tools is an integral part of the design process and shall be achieved by particularly applying measures at source to control noise, see for example EN ISO 11688-1. The success of the applied noise reduction measures is assessed on the basis of the actual noise emission values in relation to other machines of the same type with comparable non acoustical technical data.

The major sound sources of tools are: motor, fan, gear. I

I.2.1 General

Noise emission values like the emission sound pressure level L_{pA} and the sound power level L_{WA} shall be measured according to the test procedure described in I.2.2 to I.2.6.

The noise emission may be determined by using the measurements from a machine which has design and technical specifications replicating the machine concerned.

The overall noise can be divided into the pure machine noise and the noise generated from the processed workpiece. Both are influenced by the method of operation; however for percussive tools the noise emission of the workpiece can be dominant. The load conditions for particular tools are therefore specified in the relevant part of IEC 62841-2, IEC 62841-3 or IEC 62841-4.

NOTE Noise emission values obtained under these measurement conditions will not necessarily be representative for the noise produced under all possible operational conditions of practical use.

I.2.2 Sound power level determination

I.2.2.1 General

The sound power level shall be measured according to ISO 3744, where the acoustic environment, instrumentation, quantities to be measured, quantities to be determined, and the measurement procedure are specified.

The sound power level shall be given as A-weighted sound power level in dB reference 1 pW. The A-weighted sound pressure levels, from which the sound power is to be determined, shall be measured directly, and not calculated from frequency band data. Measurements shall be made in an essentially free field over a reflecting plane.

I.2.2.2 Hand-held power tools

For all **hand-held tools**, the sound power level shall be determined by using a hemispherical / cylindrical measurement surface according to Figure I.2.

The hemispherical / cylindrical measurement surface is described by a hemisphere standing on a cylindrical pedestal (see Figure I.2). Five microphone positions shall be located 1 m from the geometric centre of the power tool. Four positions shall be spaced at regular intervals on a plane defined as passing through the geometric centre of the power tool and parallel to the reflecting plane; the fifth position shall be located at a distance of 1 m above the geometric centre of the power tool.

The A-weighted sound power level, L_{WA} , shall be calculated, in accordance with of ISO 3744 as follows:

$$L_{WA} = \overline{L_{pA,1m}} + 10\lg\left(\frac{S}{S_0}\right), \text{ in dB} \quad (I.1)$$

with $\overline{L_{pA,1m}}$ determined from

$$\overline{L_{pA,1m}} = 10\lg \left[\frac{1}{5} \sum_{i=1}^5 10^{0,1L'_{pA,i}} \right] - K_{1A} - K_{2A}$$

where

- $\overline{L_{pA,1m}}$ is the A-weighted time-averaged 1 meter surface sound pressure level according to ISO 3744;
- $L'_{pA,i}$ is the A-weighted sound pressure level measured at the i^{th} microphone position, in dB;
- K_{1A} is the background noise correction, A-weighted;
- K_{2A} is the environmental correction, A-weighted;
- S is the area of the measurement surface of Figure I.2, in m^2 ;
- $S_0 = 1 \text{ m}^2$.

For the hemispherical / cylindrical measurement surface shown in Figure I.2, the area S of the measurement surface is calculated as follows:

$$S = 2\pi(R^2 + Rd), \text{ in } \text{m}^2.$$

Where $d = 1 \text{ m}$ is the height of the distance of the geometrical centre of the power tool above the reflecting plane and $R = 1 \text{ m}$ is the radius of the hemisphere and of the cylinder which comprise the measurement surface.

Therefore,

$$S = 4\pi \text{ m}^2,$$

so, from equation (I.1)

$$L_{WA} = \overline{L_{pA,1m}} + 11, \text{ in dB.}$$

I.2.2.3 Transportable power tools

For all **transportable tools**, the sound power level shall be determined by using a cubic measurement surface according to Figure I.3.

Five microphone positions shall be located in the centre of each lateral surface and the top surface of the measurement cubic surface which envelops the source.

The A-weighted sound power level, L_{WA} , shall be calculated, in accordance with ISO 3744 as follows:

$$L_{WA} = \overline{L_{pA,1m}} + 10 \lg \left(\frac{S}{S_0} \right), \text{ in dB} \quad (\text{I.2})$$

with $\overline{L_{pA,1m}}$ determined from

$$\overline{L_{pA,1m}} = 10 \lg \left[\frac{1}{5} \sum_{i=1}^5 10^{0,1L'_{pA,i}} \right] - K_{1A} - K_{2A}$$

where

- $\overline{L_{pA,1m}}$ is the A-weighted time-averaged 1 meter surface sound pressure level according to ISO 3744;
- $L'_{pA,i}$ is the A-weighted sound pressure level measured at the i^{th} microphone position, in dB;
- K_{1A} is the background noise correction, A-weighted;
- K_{2A} is the environmental correction, A-weighted;
- S is the area of the measurement surface of Figure I.3, in m^2 ;
- $S_0 = 1 \text{ m}^2$.

For the measurement surface shown in Figure I.3, the area S is calculated as follows:

$$S = 5 \times (2\text{m} \times 2\text{m}) = 20 \text{ m}^2.$$

Therefore, from equation (I.2)

$$L_{WA} = \overline{L_{pA,1m}} + 13, \text{ in dB.}$$

I.2.2.4 Lawn and garden machinery

The sound power level of **lawn and garden machinery** shall be determined as specified in the relevant part of IEC 62841-4.

I.2.3 Emission sound pressure level determination

I.2.3.1 Hand-held tools

The A-weighted emission sound pressure level at the work station, L_{pA} , shall be determined in accordance with ISO 11203 as follows:

$$L_{pA} = L_{WA} - Q, \text{ in dB}$$

where $Q = 11$, in dB.

NOTE 1 This value of Q has been determined, during experimental investigations, to be applicable to **hand-held power tools**. The resulting A-weighted emission sound pressure level at the workstation is equivalent to the value of the surface sound pressure level at a distance of 1 m from the power tool. This distance has been chosen to give satisfactory reproducibility of results, and to permit comparison of the acoustic performance of different **hand-held power tools** which do not, in general, have uniquely defined work stations. Under free field conditions, where it may be required to estimate the emission sound pressure level, $L_{pA,r1}$, at a distance r_1 in m from the geometric centre of the power tool, this can be done by applying the formula:

$$L_{pA,r1} = L_{pA} + 20 \lg\left(\frac{1}{r_1}\right), \text{ in dB}$$

NOTE 2 At any given position in relation to a particular machine, and for given mounting and operating conditions, the emission sound pressure levels determined by the method of this standard will in general be lower than the directly measured sound pressure levels for the same machine in the typical workroom where it is used. This is due to the influence of sound reflecting surfaces in the workroom compared to the free field conditions of the test specified here. A method of calculating the sound pressure levels in the vicinity of a machine operating alone in a workroom is given in ISO/TR 11690-3. Commonly observed differences are 1 dB to 5 dB, but in extreme cases the difference might be even greater.

If required, the C-weighted peak emission sound pressure level L_{pCpeak} shall be measured at each of the five measurement positions specified in I.2.2. The C-weighted peak emission sound pressure level at the work station is the highest C-weighted peak sound pressure level measured at any of the five microphone positions; no corrections are permitted.

I.2.3.2 Transportable tools

The A-weighted emission sound pressure level at the work station, L_{pA} , shall be determined according to ISO 11201, grade 2. It shall be determined under the same operating conditions as for the determination of the sound power level.

For tools measured under load and run by an operator, the microphone shall be located $(0,2 \pm 0,02)$ m to the side of the centre plane of the operator's head, on a line with the eyes, with its axis parallel to the operator's line of view, and on the side where the higher value of the A-weighted sound pressure level is observed.

For tools measured under no-load and without the operator being present, the microphone shall be located at a reference point on the ground plane on which the operator normally stands. If not specified in the relevant part of IEC 62841-3, this reference point shall be located 1 m from the centre of the tool on the side where the operator normally stands. The microphone shall be located directly above the reference point at a height in the range of $(1,55 \pm 0,075)$ m.

If required, the C-weighted peak emission sound pressure level L_{pCpeak} shall be measured at the same operator's position as the A-weighted sound pressure level L_{pA} .

I.2.3.3 Lawn and garden machinery

The emission sound pressure level of **lawn and garden machinery** shall be determined as specified in the relevant part of IEC 62841-4.

I.2.4 Installation and mounting conditions of the power tools during noise tests

The installation and mounting conditions shall be the same for the determination of both sound power level and emission sound pressure level at the work station.

The power tool under test shall be new and equipped with **accessories** which affect the acoustic properties, as recommended by the manufacturer. Prior to commencing testing, the power tool (including any required ancillary equipment) shall be set up in a stable condition in accordance with the manufacturer's instructions for safe use.

A **hand-held tool** is held by the operator or suspended in such a way as to correspond to **normal use**, as specified in the relevant part of IEC 62841-2. If the **hand-held tool** is used horizontally, it shall be positioned so that its axis is at 45° between the microphone positions 1 and 4 and 2 and 3 (see Figure I.2); its geometrical centre shall be 1 m above the ground (reflecting plane). If these requirements are impracticable or the tool is not used horizontally, the adopted positions shall be recorded and described in the test report.

A **transportable tool** shall be so positioned, either placed on the test bench of Figure I.1 or mounted on the accompanying support, that its centre of gravity is located below the top microphone position 5. The tool shall be so oriented that its front edge is parallel to one of the horizontal side edges of the measurement cube of Figure I.3.

Lawn and garden machinery shall be used and positioned as specified in the relevant part of IEC 62841-4.

The operator shall not be positioned directly between any microphone position and the power tool.

I.2.5 Operating conditions

The operating conditions shall be identical for the determination of both sound power level and emission sound pressure level at the work station.

Measurements shall be carried out on a new tool.

Tools are tested under the two operating conditions “no-load” or “load” as appropriate for the type of tool and specified in the relevant part of IEC 62841-2, IEC 62841-3 or IEC 62841-4. Before starting the test, the tool shall be operated under these conditions for a period of at least 1 min.

A measurement under “load” is to be carried out during processing of a workpiece or under external mechanical load equivalent to **normal operation**.

Where tests are required to be carried out on a bench it shall be in accordance with the test bench shown in Figure I.1.

Care shall be taken that the location of the workpiece on its support does not adversely affect the result of the test. If necessary, or when specified in the part of IEC 62841-2, IEC 62841-3 or IEC 62841-4, the workpiece shall be supported on a resilient material (20 ± 1) mm thick compressed to (10 ± 1) mm under the weight of the workpiece.

Three consecutive tests for no-load or five for load shall be carried out and the result of the test L_{WA} shall be the arithmetic mean, rounded to the nearest decibel, of the three or five tests.

During measurements, the power tool shall operate under stable conditions. Once the noise emission is steady, the measurement time interval shall be at least 15 s, unless the operating conditions specified in the relevant part of IEC 62841-2, IEC 62841-3 or IEC 62841-4 require

another time interval. If measurements are to be made in octave or one-third octave frequency bands, the minimum period of observation shall be 30 s for the frequency bands centred on or below 160 Hz, and 15 s for the frequency bands centred on or above 200 Hz.

1.2.6 Measurement uncertainties

The total measurement uncertainty of the noise emission values determined according to this standard is depending on the standard deviation σ_{R0} given by the applied noise emission measurement method and the uncertainty associated with the instability of the operating and mounting conditions σ_{omc} . The resulting total uncertainty is then calculated from

$$\sigma_{tot} = \sqrt{\sigma_{R0}^2 + \sigma_{omc}^2}$$

The upper bound value of σ_{R0} is about 1,5 dB for the grade 2 measurement methods applied in this noise test code in order to determine the emission sound pressure level or the sound power level.

NOTE 1 σ_{tot} is referred to as σ_R in ISO 4871:1996.

NOTE 2 In ISO 4871:1996, the expanded measurement uncertainty U , in decibels, is calculated from $U = k \sigma_{tot}$, with k being the coverage factor.

It depends on the degree of confidence that is desired. For the purpose of comparing the result with a limit value, it is appropriate to apply the coverage factor for a one-sided normal distribution. In that case, the coverage factor $k = 1,6$ corresponds to a 95 % confidence level. Further information is given in ISO 4871:1996. Please note that the expanded measurement uncertainty U is referred to as K in ISO 4871:1996.

NOTE 3 For machines with a rather constant noise emission, a value of 0,5 dB for σ_{omc} can apply. In other cases, e.g. a large influence of the material flow into and out of the machine or material flow that varies in an unpredictable manner, it is possible that a value of 2 dB is more appropriate. Methods to determine σ_{omc} are described in the basic measurement standards. Further guidance for determining the uncertainty K of both noise emission values is given in ISO 4871:1996.

1.2.7 Information to be recorded

The information to be recorded covers all of the technical requirements of this noise test code. Any deviations from this noise test code or from the basic standards upon which it is based are to be recorded together with the technical justification for such deviations.

1.2.8 Information to be reported

The information to be included in the test report is at least that which is required to prepare a noise emission declaration or to verify the declared values. Thus as a minimum the following information shall be included:

- reference to this noise test code and to the basic standards used;
- description of the power tool;
- description of the mounting and operating conditions;
- the noise emission values obtained.

It shall be confirmed that all requirements of the noise test code have been fulfilled, or, if this is not the case, any unfulfilled requirements shall be identified. Deviations from the requirements shall be stated and technical justification for the deviations shall be given.

1.2.9 Declaration and verification of noise emission values

The declaration of the noise emission values shall be a dual number according to ISO 4871:1996. It shall declare the noise emission value L (L_{pA} and L_{WA}) and the respective uncertainty K (K_{pA} and K_{WA}). If required, the C-weighted emission peak sound pressure level L_{pCpeak} shall be given.

For a standard deviation of reproducibility of the method σ_{R0} of 1,5 dB and for a typical standard deviation of production, the values for the uncertainties, K_{pA} and K_{WA} respectively, are expected to be 3 dB.

The noise declaration shall state that the noise emission values have been obtained according to this noise test code. If this statement is not true, the noise declaration shall indicate clearly what the deviations from this standard, and from the basic standards, are.

NOTE If the measured value is the average based on a sample of three power tools that has been properly sampled, then K normally is 3 dB. Further guidance on sampling and uncertainty terms is given in ISO 7574-4 and ISO 4871:1996.

Additional noise emission quantities may also be given in the declaration.

If undertaken, the verification shall be performed for a batch of power tools, in accordance with 6.3 of ISO 4871:1996. The verification shall be conducted by using the same mounting, installation and operating conditions as those used for the initial determination of noise emission values.

I.3 Vibration

☐ I.3.Z1 Vibration reduction

The vibration at the handles shall be kept as low as possible without unduly affecting the performance and the ergonomics (weight, handling, etc.) of the tool.

In particular vibration shall be reduced by the application of engineering measures as given in CR 1030-1. The success of the applied vibration measures is assessed by comparing the vibration levels for the tool with those for other tools of the same type and with a comparable specification and performance. ☐

I.3.1 Vibration measurement – General

Details for particular types of tools are given in the relevant part of IEC 62841-2, IEC 62841-3 or IEC 62841-4. The test code gives all the information necessary to carry out efficiently the determination, declaration and verification of the vibration emission characteristics. It shall allow comparison of test results for different tools.

The vibration total value may be determined by using the measurements from a machine which has design and technical specifications replicating the machine concerned.

EN 12096 gives guidance on how to declare the vibration total values of machinery, and specifies requirements for verification of declared values.

The vibration levels for hand-arm vibration a_h to be quoted in the user instructions shall be measured in accordance with the following test procedure.

The uncertainty K is provided as an indication of the measured deviation from the mean during the test.

The measurement and assessment of human exposure to hand-transmitted vibration in the workplace is given in ISO 5349-1 and ISO 5349-2.

NOTE The following does not constitute an exhaustive list of possible sources of errors of measurement, but can be considered as a guide to avoid the main errors in measurement:

- a) unsuitable mounting or fastening of transducers;
- b) inadequate fastening of cables;

- c) lack or misadjustment of band-pass filter;
 - d) not nulling output of amplifiers after mounting of transducers;
 - e) misalignment of directions of transducers or inappropriate or varying position of the transducers;
 - f) inappropriate signal conditioning (band-pass, signal-to-noise ratio, overload, etc.);
 - g) too short duration of measurement;
 - h) lack of calibration before and after measurement;
 - i) inappropriate definition of operational conditions;
 - j) inexperienced operators using inappropriate grip forces;
 - k) unstable operating conditions, such as fluctuating feed forces and varying motor speed.
- Further practical advice on measurement errors is given in ISO 5349-2.

1.3.2 Symbols

In Clause 1.3, the following symbols are used:

$a_{hw}(t)$	instantaneous single-axis acceleration value of the frequency-weighted hand-transmitted vibration at time t , in m/s^2
a_{hw}	root-mean-square (r.m.s.) single-axis acceleration value of the frequency-weighted hand-transmitted vibration, in m/s^2
$a_{hwx}, a_{hwy}, a_{hwz}$	values of a_{hw} in m/s^2 , for the axes denoted X, Y and Z respectively
a_{hv}	vibration total value of frequency-weighted r.m.s. acceleration, in m/s^2 ; it is the root-sum-of-squares of the a_{hw} values for the three measured axes of vibration
a_h	arithmetic mean total vibration value of the measurement results of all runs and operators in m/s^2 , this is the result of the test
σ_R	standard deviation of reproducibility
K	uncertainty of a_h in m/s^2
C_V	coefficient of variation of a test series, defined as the ratio of the standard deviation of a series of measurement values and the mean value of the series:

$$C_V = \frac{s_{N-1}}{\bar{a}_{hv}}$$

where

$$s_{N-1} = \sqrt{\frac{1}{N-1} \sum_{i=1}^N (a_{hvi} - \bar{a}_{hv})^2}$$

is the standard deviation;

\bar{a}_{hv} is the mean vibration total value of the series of 5 measurements in m/s^2 ;

a_{hvi} is the i -th vibration total value of one series of measurements in m/s^2 ;

N is the number of measured values within one series of measurements (here $N = 5$).

I.3.3 Characterisation of vibration

I.3.3.1 Direction of measurement

Vibration transmitted to the hand is related to the three orthogonal directions X, Y and Z as shown in Figure I.4. For particular types of tools, these directions may be defined in the relevant part of IEC 62841-2, IEC 62841-3 or IEC 62841-4.

I.3.3.2 Location of measurement

Measurements shall be made in three directions at each hand position. All measurements shall be conducted simultaneously.

Measurements shall be carried out as close as possible to the hand between the thumb and the index finger, where an operator normally holds the machine.

If gripping areas are covered by soft surface material, precaution shall be taken to avoid resonance effects of the transducer mounting. If soft surface material is provided in the gripping area it shall be removed or strongly compressed by a transducer mounting clamp or suitable adaptor.

The measurement positions for particular types of tools are specified in the relevant part of IEC 62841-2, IEC 62841-3 or IEC 62841-4.

When machines are operated with more than one grip or grasping surface, the vibration at the hand positions where an operator normally holds the tool during **normal operation** shall be measured and recorded. If it can be shown that the vibration magnitude at one grip is always dominant, the vibration test code may specify that measurements are made only at that gripping zone.

I.3.3.3 Magnitude of vibration

The quantity used to describe the magnitude of vibration shall be the frequency-weighted acceleration a_{hw} in m/s^2 .

Frequency weighting in accordance with ISO 5349-1 shall be used.

The r.m.s. value a_{hw} in accordance with this standard is defined as the r.m.s. value of the frequency-weighted acceleration signal $a_{hw}(t)$:

$$a_{hw} = \left[\frac{1}{T} \int_0^T a_{hw}^2(t) dt \right]^{1/2}$$

An integrating device equipped with linear integration facilities shall be used in order to obtain r.m.s. values of signals substantially varying with time.

The measurement time shall be as long as reasonably possible and normally not less than 8 s for hand-transmitted vibration measurements.

If the measurement time of 8 s for individual machines is not possible, e.g. because of short duration of operation (defined in I.3.5.3), this shall be specified in the relevant part of IEC 62841-2, IEC 62841-3 or IEC 62841-4.

I.3.3.4 Combination of vibration directions

The vibration total value a_{hv} is determined from

$$a_{hv} = [a_{hwx}^2 + a_{hwy}^2 + a_{hwz}^2]^{1/2} \quad (I.3)$$

where

a_{hwx} , a_{hwy} , a_{hwz} are the r.m.s. values of the frequency-weighted acceleration in the directions X, Y and Z, respectively.

I.3.4 Instrumentation requirements

I.3.4.1 General

The vibration measurement equipment shall be in accordance with ISO 8041.

Instrumentation for measuring other parameters (e.g. for controlling the working conditions), whose characteristics are not covered by ISO 8041, shall be specified in the relevant part of IEC 62841-2, IEC 62841-3 or IEC 62841-4.

I.3.4.2 Transducers

I.3.4.2.1 Specification of transducers

The vibration values as specified in I.3.3.3 shall be measured using transducers and other appropriate measurement equipment conforming to ISO 8041.

The total mass of the vibration transducer and its mounting shall not be sufficient to influence the measurement result and shall not be more than 5 g for each direction of measurement.

NOTE Lightweight plastic handles are an example, where heavy transducers may not be suitable. See ISO 5349-2 for further information.

Factors such as the transverse sensitivity (less than 10 %), the ambient temperature range, the typical temperature transient sensitivity and the maximum shock acceleration shall be considered in the selection of transducers.

I.3.4.2.2 Fastening of transducers

Guidance on mounting of transducers is given in ISO 5349-2. The transducer and the mechanical filter, if used, shall be mounted rigidly and on the vibrating surface.

Mechanical filters or other appropriate means may be needed to minimize measurement errors likely to occur when measuring vibration containing impulsive elements, such as occur in percussive tools. For more details, see ISO 5349-2.

NOTE High acceleration in the high-frequency components of the vibration can cause the transducer to generate false signals (e.g. dc shift) in the frequency range of interest because of excitation of the resonance of the transducer itself.

I.3.4.3 Calibration of the measurement chain

The whole measurement system shall be checked both before and after a sequence of measurements using a calibrator which produces a known acceleration at a known frequency.

The transducers shall be calibrated in accordance with ISO 5347 and ISO 16063-1. The whole measurement system shall be checked according to the requirements in ISO 8041.

I.3.5 Testing and operating conditions of the tool

I.3.5.1 General

Measurements shall be carried out on a new tool that is only used for the noise and vibration tests required by this standard.

For mains operated tools: The average voltage during the test shall not deviate from the **rated voltage** or the mean value of the **rated voltage range** by more than ± 1 %.

For battery-operated tools: Each operator shall start his series of tests with a fully charged battery.

- Ⓒ) When the test procedure is not provided in a relevant part of EN 62841-2, EN 62841-3 or EN 62841-4, an operating condition shall be specified that is reproducible and representative of the noisiest operation in typical usage of the tool. The vibration test may simulate a single phase of a task or a working cycle, consisting of a set of operations where the operator is being exposed to vibration. However, the operating condition for the noise emission test shall, if practicable, also be used for the vibration test. Ⓒ)

If for reasons of better reproducibility a simulated work condition is defined, the vibration source shall produce approximately the same magnitude of vibration as that in a typical working situation. If necessary to provide realistic emission levels, tests shall be carried out under more than one operating condition or set of operating conditions as defined in the relevant part of IEC 62841-2, IEC 62841-3 or IEC 62841-4.

If the tool is equipped with means or devices to reduce the vibration emission in comparable operating conditions, these shall be used, in accordance with the user instructions, during vibration testing. If this requires a deviation from the type test method, this shall be reported and explained in the test report.

During the measurements the hands of the operator shall guide the machine as is necessary by the design of the tool and as specified in the instructions supplied with the machine.

I.3.5.2 Attachment, workpiece and task

The **attachment** or **accessories** to be used with the machine shall be as recommended in the user instruction.

If these **attachments** are of a vibration reduction type, it shall be reported together with the declared vibration value.

Care shall be taken that the location of the workpiece on its support does not affect the results of the test. Details for task and workpiece are given in the relevant part of IEC 62841-2, IEC 62841-3 or IEC 62841-4.

NOTE Even small differences in size, shape, material, wear, unbalance, etc. of the **accessory** can alter the vibration magnitude considerably.

I.3.5.3 Operating conditions

Tools are tested under load only, unless the operating condition no-load is considered as important in practical use (no-load accounts for more than 20 % of the time when tool is switched on). In this case the tool shall be tested under both load and no-load condition, or at a typical work cycle containing load and no-load. The relevant part of IEC 62841-2, IEC 62841-3 or IEC 62841-4 describes the modes of operation and the calculation of the declared emission value.

The machine shall be operated at normal working conditions and working modes according to the user instructions, which shall be maintained for the duration of the test. Those operating

conditions shall be used that are representative of the highest vibration values likely to occur at typical and **normal use** of the machine under test. The measurement may be carried out by processing a workpiece or under external mechanical load equivalent to **normal operation**.

Before starting the test, the tool shall be operated under these conditions of at least 1 min to warm it up.

I.3.5.4 Operator

The vibration of the machine is influenced by the operator. The operator shall therefore be skilled and able to operate the machine properly, i.e. he shall be experienced in the use of the tool.

The gripping force shall be as under long term working conditions and not be excessive.

I.3.6 Measurement procedure and validity

I.3.6.1 Reported vibration values

Three series of five consecutive tests shall be carried out using a different operator for each series. If it can be shown that the vibration is not affected by operator characteristics, it is acceptable to perform all 15 measurements with one operator only. Details are specified in the relevant part of IEC 62841-2, IEC 62841-3 or IEC 62841-4.

The measurements are made in three axes and the results of each direction shall be combined using equation (I.3) to obtain the vibration total value a_{hV} .

If the coefficient of variation C_V of the five vibration total values a_{hV} , recorded for each series, is less than 0,15 or the standard deviation s_{N-1} is less than $0,3 \text{ m/s}^2$, the results are accepted (the note in I.3.1 provides information on possible sources of errors of measurement).

The measurement result a_h shall be determined as the arithmetic mean of vibration total values over the tests and operators.

I.3.6.2 Declaration of the vibration total value

The result a_h is the basis for the declared value. If values have been obtained for different hand positions, the greatest value shall be the basis for the declaration.

If required by the relevant part of IEC 62841-2, IEC 62841-3 or IEC 62841-4, the work mode description corresponding to the vibration emission shall be stated next to each declared value.

To determine the uncertainty K of the declared value according to EN 12096, the following formula shall be used that takes the standard deviation into account:

$K = 1,65 s_R$ or $K = 1,5 \text{ m/s}^2$, whatever is higher

$$s_R = \sqrt{\frac{1}{n-1} \sum_{i=1}^n (a_{hvi} - a_h)^2}$$

with

s_R = standard deviation (considered equal to σ_R);

n = 3 (number of operators);

a_{hvi} = average vibration total value of each operator (= result for each operator);

a_h = average vibration total value of all measurements (= test result).

The vibration value(s) a_h shall be declared as follows:

Vibration total values (triaxial vector sum) determined according to [number of this standard]:

Work mode description 1 (if required by the relevant part of IEC 62841-2, IEC 62841-3 or IEC 62841-4)	Vibration emission value $a_h = \dots \text{ m/s}^2$ Uncertainty $K = \dots \text{ m/s}^2$
Work mode description 2 (if required by the relevant part of IEC 62841-2, IEC 62841-3 or IEC 62841-4)	Vibration emission value $a_h = \dots \text{ m/s}^2$ Uncertainty $K = \dots \text{ m/s}^2$

I.3.7 Measurement report

The report shall, as a minimum, include the following information:

- a) reference to this standard including any relevant part of IEC 62841-2, IEC 62841-3 or IEC 62841-4;
- b) specification of the machine tested (i.e. manufacturer, type and serial number of the machine, etc.);
- c) **attachments** or **accessories**;
- d) operating and testing conditions (voltage, current, feed force, speed setting, duration and number of test runs, etc.);
- e) measuring institution (e.g. laboratory, manufacturer);
- f) date of measurement and name of the person responsible for the test;
- g) instrumentation (transducer mass, filters, integrators, recording system, etc.);
- h) position and fastening of transducers, measuring directions and individual vibration values when relevant (e.g. recorded by photos);
- i) the arithmetic mean total vibration a_h , for each operator the total vibration value a_{hv} and the three single axis weighted acceleration values a_{hw} . It is good practice to report all the measured values (i.e. for all axes of vibration, tests and operators);
- j) the uncertainty K of the vibration total value a_h .

Any deviations from the vibration test code in this standard shall be reported together with the technical justification for such deviations.

Dimensions in millimetres

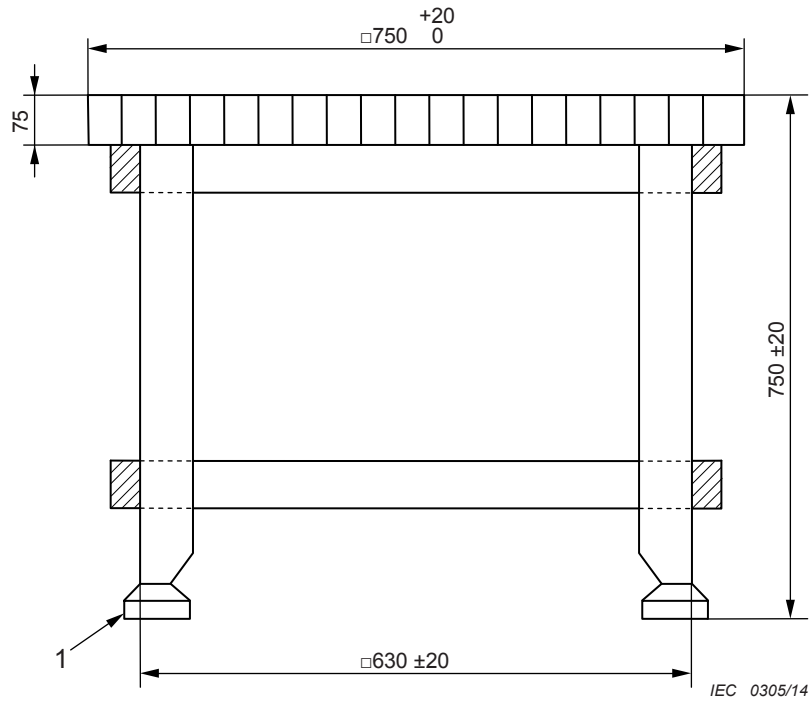

Key

1 rubber isolating feet

Material: pine wood 75 × 40 planed, glued and doweled

Figure I.1 – Test bench

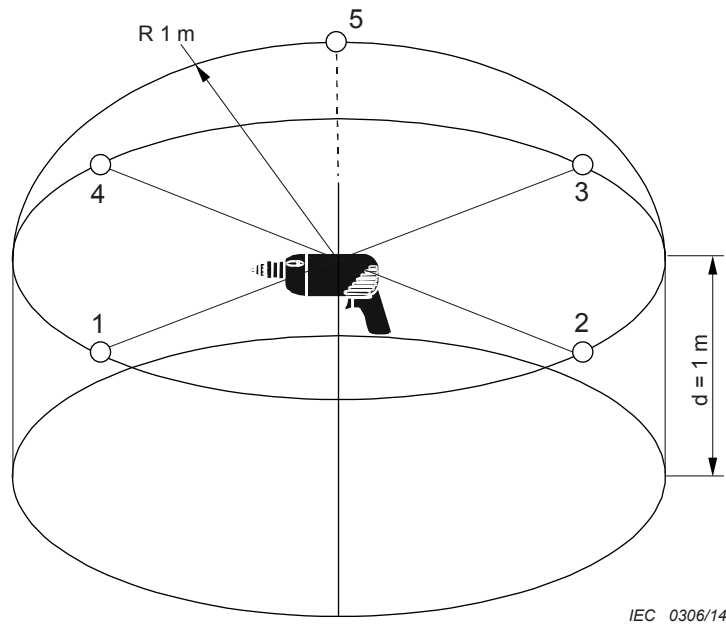

Figure I.2 – Positions of a hand-held power tool and microphones for the hemispherical / cylindrical measurement surface

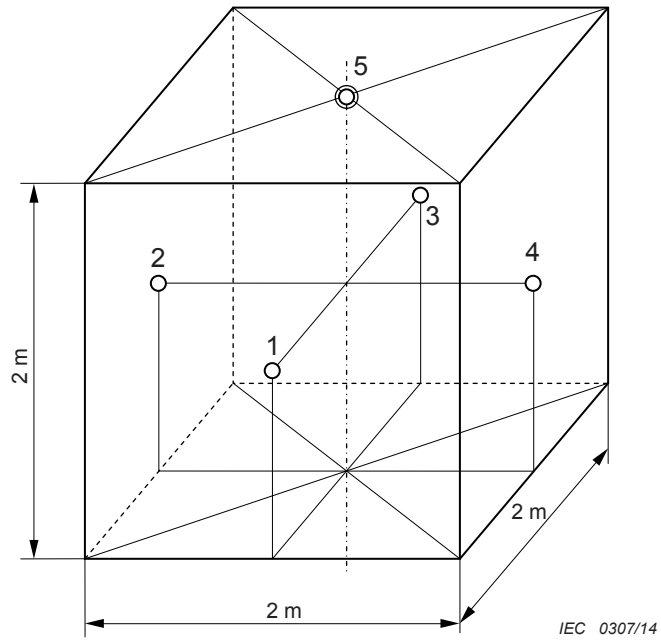
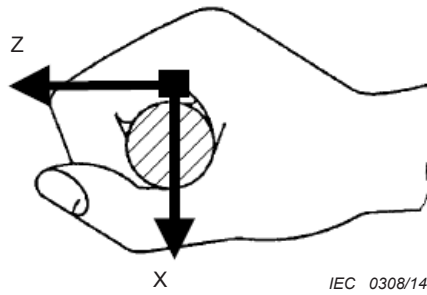
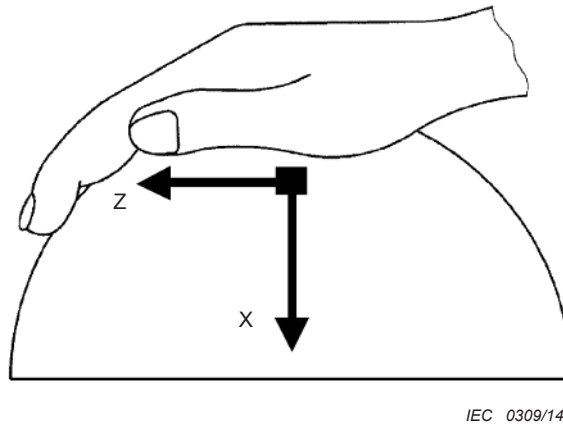

Figure I.3 – Microphone positions on a cubic measurement surface



a) Hand grip position – Hand grips around a cylindrical handle



b) Flat palm position – Hand presses down onto a spherical hand grip

Figure I.4 – Directions of vibration measurement

Annex J

Void

Annex K (normative)

Battery tools and battery packs

K.1 Scope

This annex applies to rechargeable **battery**-powered motor-operated or magnetically driven

- **hand-held tools** (IEC 62841-2);
- **transportable tools** (IEC 62841-3);
- **lawn and garden machinery** (IEC 62841-4);

and the **battery** packs for such tools or machinery. The above listed categories are hereinafter referred to as “tools” or “machines”.

The maximum **rated voltage** for tools and **battery** packs is 75 V d.c.

Battery tools covered by this annex are not considered to be **class I tools**, **class II tools**, or **class III tools** and therefore are not required to have basic, **supplementary insulation** or **reinforced insulation**. Electric shock hazard is considered to exist only between parts of opposite polarity.

Battery packs for tools covered under this annex intended to be charged by a non-isolated **charger** shall be evaluated by this annex and standard. When evaluating a **battery** pack for protection against electric shock, **creepage distances**, **clearances** and distances through insulation, the **battery** pack shall be fitted to the intended **charger**.

Since **battery** packs for power tools are submitted to different use patterns (such as rough use, high charging and discharging currents) their safety can be evaluated only by this annex and not by using other standards for **battery** packs, such as IEC 62133, unless otherwise indicated in this annex. All relevant requirements of IEC 62133 are addressed in this annex.

When evaluating the risk of **fire** associated with **detachable battery packs**, consideration has been given to the fact that these **battery** packs are unattended energy sources and have been evaluated as such in this standard. Requirements in other standards regarding the risk of **fire** due to the charging of these **detachable battery packs** are therefore considered to be fulfilled.

This annex also addresses requirements covering the use of lithium-ion **cells** employed in **battery systems** in tools. The following is considered within the context of these requirements:

- These requirements address the risk of **fire** or **explosion** of these **batteries** and not any possible hazards associated with toxicity nor potential hazards associated with transportation or disposal.

NOTE 1 IEC 62281 covers the safety aspects of lithium-ion batteries during transport.

- **Battery systems** covered by these requirements are not intended to be serviced by the end user.
- These requirements are intended to provide comprehensive evaluation of a **battery** only if used in products covered by this standard.
- These requirements address the safety of lithium-ion **battery systems** during storage and use including discharge and charge. These requirements are only considered to be supplementary requirements in regards to battery **charger** fire and electric shock.

- These requirements refer to and require parameters supplied in reference to the **cells** that establish conditions for safe use of those **cells**. Those parameters form the basis of acceptance criteria for a number of tests contained herein. This standard does not independently evaluate the safety of **cells**. These parameters, taken as a set, constitute the “**Specified Operating Region**” for a **cell**. There may be several sets of **specified operating region(s)**.

This annex is not intended to apply to tools using **general purpose batteries** installed by the user and this annex alone will not be sufficient to ensure all hazards are considered for these products.

This annex does not apply to the safety of battery **chargers** themselves. However, this annex covers the safe functioning of lithium-ion **battery systems**.

NOTE 2 IEC 60335-2-29 covers a variety of **chargers**.

All clauses of this standard apply unless otherwise specified in this annex. If a clause is stated in the annex, the requirements replace the requirements of the main body of the standard unless otherwise specified.

K.3 Terms and definitions

This clause is applicable except as follows:

For the purpose of this annex, the following additional definitions apply.

K.3.201

battery system

combination of a lithium-ion **battery**, the **charging system**, the tool and the interfaces between them as existing during operation of the tool or during charging

K.3.202

cell

basic functional electrochemical unit containing an assembly of electrodes, electrolyte, container, terminals, and usually separators, that is a source of electrical energy by direct conversion of chemical energy

K.3.203

charger

part or all of the **charging system** contained in a separate enclosure. As a minimum, the **charger** includes some of the power conversion circuitry. Not all **charging systems** include a separate **charger** as in the case where a tool may be charged utilizing a mains **supply cord** or may incorporate a plug for attachment to a mains receptacle

K.3.204

charging system

combination of circuitry intended to charge, balance and/or maintain the state of charge of the **battery**

K.3.205

C₅ rate

current, in amperes, that a **cell** or **battery** can be discharged at for 5 h to the voltage cut-off point specified by the **cell** manufacturer

K.3.206

detachable battery pack

battery which is contained in a separate enclosure from the battery tool and is intended to be removed from the tool for charging purposes

K.3.207

fire

emission of flames from a **battery**

K.3.208

fully charged (battery/cell)

cell or **battery** charged to the maximum state of charge permitted by the **battery charging system** intended for use with the tool

K.3.209

fully discharged (battery/cell)

battery or **cell** that has been discharged at **C₅ rate** until one of the following conditions occurs: discharge terminates due to protective circuitry or the **battery** (or **cell**) reaches a total voltage with an average voltage per cell equal to the end-of-discharge voltage for the cell chemistry being used unless a different end-of-discharge voltage is specified by the manufacturer

Note 1 to entry: The end-of-discharge voltages for common cell chemistries are provided in K.5.210.

K.3.210

general purpose (batteries/cells)

batteries and **cells** available from a variety of manufacturers, through a variety of outlets intended for a variety of different manufacturers' products

Note 1 to entry: 12 V automotive **batteries** and AA, C and D alkaline **cells** are examples of **general purpose**.

K.3.211

hazardous voltage

voltage between parts having an average value exceeding 60 V d.c. or exceeding 42,4 V peak when the peak-to-peak ripple exceeds 10 % of the average value

K.3.212

integral battery

battery which is contained within the battery tool and is not removed from the battery tool for charging purposes

Note 1 to entry: A **battery** that is to be removed from the battery tool for disposal or recycling purposes only is considered to be an **integral battery**.

K.3.213

maximum charging current

highest current that a lithium-ion **cell** is permitted to pass during charging for a specified range of temperatures as specified by the **cell** manufacturer and evaluated in accordance with IEC 62133

K.3.214

separable battery pack

battery which is contained in a separate enclosure from the battery tool and is connected to the battery tool by a cord

K.3.215

specified operating region

range of permissible operation of lithium-ion **cells**, expressed by **cell** parameter limits

K.3.215.1**specified operating region for charging**

conditions for voltage and current during charging in which the lithium-ion **cell** is permitted to operate as specified by the **cell** manufacturer and evaluated in accordance with IEC 62133

K.3.216**upper limit charging voltage**

highest voltage that a lithium-ion **cell** is permitted to attain during normal charging for a specified range of temperatures as specified by the **cell** manufacturer and evaluated in accordance with IEC 62133

K.3.217**venting**

condition that occurs, when a **cell** releases excessive internal pressure intended by design to preclude **explosion**

K.5 General conditions for the tests**K.5.2** *Addition:*

*The cumulative stress resulting from successive tests on the **battery** is to be avoided. Additional samples may be used as necessary.*

K.5.7 *Unless otherwise specified, tests to be done at **rated voltage** are done with a **fully charged battery**.*

K.5.10 This subclause is not applicable.

K.5.11 This subclause is not applicable.

K.5.15 This subclause is not applicable.

K.5.16 This subclause is not applicable.

K.5.201 *When measuring voltage, the peak value of any superimposed ripple exceeding 10 % of the average value shall be included. Transient voltages are ignored, such as a temporary increase of voltage, for example after the **battery pack** is removed from the **charger**.*

K.5.202 *Measurements of **cell** voltages during the tests of lithium-ion systems shall be made using a single pole resistive-capacitive low pass filter with a cut-off frequency of 5 KHz \pm 500 Hz. If charging voltage limits have been exceeded, the peak value of the voltage measured after this network shall be used. The measurement shall have measurement tolerance within \pm 1 %.*

K.5.203 *Some of the tests may result in **fire** or **explosion**. It is therefore important that personnel be protected from the flying fragments, explosive force, sudden release of heat, chemical burns, intense light and noise that may result from such **explosions**. The test area is to be well ventilated to protect personnel from possible harmful fumes or gases.*

K.5.204 *Unless otherwise specified, all **batteries** shall be fully conditioned as follows: **batteries** shall be **fully discharged** and then charged in accordance with the manufacturer's instructions. The sequence shall be repeated one more time with an interval of at least two hours after each discharge.*

K.5.205 *The location of thermocouples for lithium-ion **cell** temperature measurements shall be on the outer surface, half way along the longest dimension, of the **cell** that results in the highest temperature.*

K.5.206 *Currents measured during **battery** charging shall be average currents with an averaging period of 1 s to 5 s.*

K.5.207 *If not otherwise specified, a **fully charged battery** shall be used. After removal from the **charging system** and before starting a test, the **fully charged battery** shall be allowed to rest for at least 2 h but no more than 6 h at an ambient temperature of $(20 \pm 5) ^\circ\text{C}$.*

K.5.208 *When a **battery** comprising of a single **cell** is employed, instructions in this standard referring to special preparations of a **cell** in a series configuration shall be ignored.*

K.5.209 *For **battery** designs where there is a series arrangement of parallel clusters of **cells**, the cluster shall be treated as a single **cell** for those tests that require altering the amount of charge on a single **cell** prior to conducting the test.*

K.5.210 *The end-of-discharge voltages for common cell chemistries are:*

- 0,9 V/cell for nickel cadmium or nickel metal-hydride **batteries**;
- 1,75 V/cell for lead-acid **batteries**;
- 2,5 V/cell for lithium-ion **batteries**, unless the manufacturer specifies a different voltage.

K.7 Classification

This clause is not applicable.

K.8 Marking and instructions

K.8.1 This subclause is not applicable.

K.8.3 Battery tools and **detachable battery packs** or **separable battery packs** shall be marked with additional information as follows:

- the business name and address of the manufacturer and, where applicable, his authorised representative. Any address shall be sufficient to ensure contact. Country or state, city and postal code (if any) are deemed sufficient for this purpose;
- designation of series or type, allowing the technical identification of the product. This may be achieved by a combination of letters and/or numbers and may be combined with the designation of tool.

NOTE 1 The term “designation of series or type” is also known as model number.

Battery tools shall also be marked with additional information as follows:

- the year of manufacture and a date code identifying at least the month of manufacture;
- designation of the tool, designation of the tool may be achieved by a code that is any combination of letters, numbers or symbols providing that this code is explained by giving the explicit designation such as “drill”, “planer” etc. in the instructions supplied with the tool;

NOTE 2 An example of such code is “A123-B”.

- for tools manufactured such that its parts are shipped separately for assembly by the end user each part shall be marked with a distinct identification on the part or the package.

Separable and **detachable battery packs** shall also be marked with additional information as follows:

- the capacity assigned by the manufacturer in Ah or mAh, based on the rated capacity of the **cells** determined in accordance with IEC 61056-1, IEC 61960, IEC 61951-1 and IEC 61951-2, as applicable;
- for alkaline or other non-acid electrolyte **batteries**, the type of **battery** such as Li-Ion, NiCd and NiMH.

NOTE 3 In Canada and the United States of America, the following additional requirements apply.

A battery tool provided with a **detachable battery pack** or a **separable battery pack** shall be marked: "For use only with ___ battery", or the equivalent, where the underlined space is completed with the manufacturer's name or trademark, a catalog number, a series identification, or the equivalent, of the **battery** pack. Alternatively, the statement "See Instruction Manual for Additional Battery Packs" or the equivalent may be employed in addition to at least one **battery** pack referenced by catalog number.

A **detachable battery pack**, a **separable battery pack**, or a **battery** tool provided with an **integral battery** shall be marked "For use only with ___ charger", or the equivalent, where the underlined space is completed with the manufacturer's name or trademark, a catalog number, a series identification, or the equivalent, of the **charger**. Alternatively, the statement "See Instruction Manual for Additional Chargers," or the equivalent may be employed in addition to at least one **charger** referenced by catalog number.

If additional markings are used, they shall not give rise to misunderstanding.

Compliance is checked by inspection.

K.8.4 Markings specified in K.8.1, 8.2 and K.8.3 shall not be on a **detachable part** of the tool.

Markings specified in 8.2 shall be clearly discernible from the outside of the tool. Markings specified in K.8.3 shall be visible with any **separable battery pack** or **detachable battery pack** removed. Other markings on the tool may be visible after removal of a cover, if necessary.

Indications for switches and controls shall be placed on or in the vicinity of these components; they shall not be placed on parts which can be repositioned, or positioned in such a way that the marking is misleading.

Compliance is checked by inspection.

K.8.7 This subclause is not applicable.

K.8.8 This subclause is not applicable.

K.8.14.1.1 This subclause is applicable except as follows:

Item 5) Service, is replaced by the following:

5) Battery tool use and care

- a) **Recharge only with the charger specified by the manufacturer.** *A charger that is suitable for one type of battery pack may create a risk of fire when used with another battery pack.*
- b) **Use power tools only with specifically designated battery packs.** *Use of any other battery packs may create a risk of injury and fire.*
- c) **When battery pack is not in use, keep it away from other metal objects, like paper clips, coins, keys, nails, screws or other small metal objects, that can make a connection from one terminal to another.** *Shorting the battery terminals together may cause burns or a fire.*

- d) **Under abusive conditions, liquid may be ejected from the battery; avoid contact. If contact accidentally occurs, flush with water. If liquid contacts eyes, additionally seek medical help.** *Liquid ejected from the battery may cause irritation or burns.*
- e) **Do not use a battery pack or tool that is damaged or modified.** *Damaged or modified batteries may exhibit unpredictable behaviour resulting in fire, explosion or risk of injury.*
- f) **Do not expose a battery pack or tool to fire or excessive temperature.** *Exposure to fire or temperature above 130 °C may cause explosion.*

NOTE The temperature „130 °C“ can be replaced by the temperature „265 °F“.

- g) **Follow all charging instructions and do not charge the battery pack or tool outside the temperature range specified in the instructions.** *Charging improperly or at temperatures outside the specified range may damage the battery and increase the risk of fire.*

6) Service

- a) **Have your power tool serviced by a qualified repair person using only identical replacement parts.** *This will ensure that the safety of the power tool is maintained.*
- b) **Never service damaged battery packs.** *Service of battery packs should only be performed by the manufacturer or authorized service providers.*

K.8.14.2 This subclause is applicable except as follows:

Addition:

e) For battery tools:

- 1) Instructions regarding **battery** charging, information regarding ambient temperature range for tool and **battery** use and storage, and the recommended ambient temperature range for the **charging system** during charging;
- 2) For a battery-operated tool intended for use with a **detachable battery pack** or a **separable battery pack**: instructions indicating the appropriate **battery** packs for use, such as by a catalog number, series identification or the equivalent;
- 3) Instructions indicating the appropriate **charger** for use, such as by a catalog number, series identification or the equivalent.

☐ Z1) For battery tools with integral battery: instruction, how the integral battery can be removed safely from the tool after the tool's end of life, and information about the type of battery such as Li-Ion, NiCd and NiMH. ☐

K.9 Protection against electric shock

NOTE The title of this clause differs from that of the main standard.

K.9.1 Battery tools and **battery** packs shall be so constructed and enclosed that there is adequate protection against electric shock.

Compliance is checked by inspection, and by the tests of K.9.3 and K.9.5, as applicable.

K.9.2 This subclause is not applicable.

K.9.3 It shall not be possible to have two conductive, simultaneously **accessible parts** where the voltage between them is hazardous unless they are provided with **protective impedance**.

In the case of **protective impedance** the short circuit current between the parts shall not exceed 2 mA for d.c. or 0,7 mA peak for a.c. and there shall not be more than 0,1 μ F capacitance directly between the parts.

Compliance for accessibility is checked by applying the test probe B of IEC 61032:1997 to each conductive part.

The test probe B of IEC 61032:1997 is applied with a force not exceeding 5 N through openings to any depth that the test probe will permit, and it is rotated or angled before, during and after insertion to any position.

If the opening does not allow the entry of the probe, a rigid test probe with the dimensions of the test probe B of IEC 61032:1997, but without any articulation, is used, the force on the probe is increased to 20 N and the test with the articulated test probe B of IEC 61032:1997 repeated.

*Contact with the test probe is determined with all **detachable parts** removed and the battery tool operated in any possible position of **normal use**.*

*Lamps located behind detachable covers are not removed, providing the lamp may be de-energized by means of a user operable plug, **battery** pack disconnection or a switch.*

K.9.4 This subclause is not applicable.

K.9.5 Materials providing insulation from electric shock shall be adequate.

Compliance is checked by subjecting the insulating material to an electric strength test as specified in Clause D.2 with 750 V. This provision does not exclude the testing of the material as situated within the tool, providing care is taken to ensure that materials not under consideration are not subjected to the test voltage.

*This test applies only to materials which, if they were to fail to insulate, would subject the user to a shock hazard from a **hazardous voltage**. This test does not apply to materials that provide only a physical barrier to contact. As such, an uninsulated energized part shall be within 1,0 mm of the material surface to be considered for this requirement.*

K.10 Starting

This clause is not applicable.

K.11 Input and current

This clause is not applicable.

K.12 Heating

K.12.1 Battery tools and **battery** packs shall not attain excessive temperatures.

Compliance is checked by determining the temperature rise of the various parts under the following conditions:

The tool is operated at no-load

– *continuously; or*

– for tools with an **inherent operating cycle**: operation with consecutive operating cycles

until maximum temperature is reached or the tool no longer operates due to the **battery** being discharged.

During the test, **protective devices** shall not operate. The temperature rises shall not exceed the values shown in Table 2.

K.12.2 to K.12.6 These subclauses are not applicable.

K.12.201 Normal charging of lithium-ion systems

Charging a lithium-ion **battery** under normal conditions shall not exceed the **specified operating region for charging** of the cell.

Compliance is checked by the following tests.

The **battery** is charged in accordance with the **charging system** instructions starting with a **fully discharged battery**. Testing is carried out at an ambient temperature of $(20 \pm 5) ^\circ\text{C}$ and

- if the tool is recommended to be operated at a minimum temperature lower than $4 ^\circ\text{C}$, the test is also conducted at that minimum temperature $_{-5}^0 ^\circ\text{C}$;
- if the tool is recommended to be operated at a maximum temperature greater than $40 ^\circ\text{C}$, the test is also conducted at that maximum temperature $_0^{+5} ^\circ\text{C}$.

For all individual **cells**, the voltage, the temperature measured in accordance with K.5.205 and the charging current are monitored. In the case of parallel configurations, analysis may be used to avoid measuring the individual branch currents. The result shall not exceed their **specified operating region for charging** (e.g. limits of voltage and current dependant on the temperature).

NOTE 1 The following is an example result of such analysis: the charging current for each branch of a parallel connection would not need to be monitored, if the maximum deliverable current of the **charger** did not exceed the **maximum charging current** of a single cell.

For **batteries** employing series configurations, the test is repeated with a deliberately imbalanced **battery**. The imbalance is introduced into a **fully discharged battery** by charging one cell to approximately 50 % of full charge.

If it can be demonstrated through testing and/or design evaluation that an imbalance less than 50 % would actually occur in **normal use**, then this lower imbalance may be used.

NOTE 2 Examples are those designs that employ circuitry intended for maintaining balance between **cells** in the **battery** pack. Systems with a small number of **cells** in series may be shown to exhibit limited imbalance in practice, if the product ceases to operate with a **battery** prepared with a smaller initial imbalance.

NOTE 3 An example for a testing is repeated charging and discharging a **battery** in accordance with the manufacturer's instructions until its capacity has decreased to 80 % of the rated capacity, using the imbalance at the end of the test.

K.13 Resistance to heat and fire

K.13.1 Parts of thermoplastic material provided as an enclosure to comply with Clause K.9, the deterioration of which might cause the tool or **battery** pack to fail to comply with this annex, shall be sufficiently resistant to heat.

Compliance is checked by subjecting of the relevant parts to a ball pressure test of IEC 60695-10-2:2003. Any soft materials (elastomers), such as soft grip coverings, shall be removed.

The required thickness may be obtained by using two or more sections of the part.

The test is made in a heating cabinet at a temperature of (55 ± 2) °C plus the maximum temperature rise determined during the test of K.12, but for external parts it shall be at least (75 ± 2) °C.

NOTE In Clause K.12 only outside temperatures are measured. The basic temperature of (40 ± 2) °C has been changed to (55 ± 2) °C representing the typical difference between the inside and outside temperatures of enclosures.

K.13.2 This subclause applies only to the external enclosure enclosing the current-carrying parts of the tool or **battery** pack.

Addition:

*Non-metallic parts of a **detachable** or **separable battery pack** or non-metallic parts of a tool that contains an **integral battery** supporting connections that carry a current exceeding 0,2 A during charging and non-metallic parts within a distance of 3 mm of such connections, are subjected to the glow-wire test of IEC 60695-2-11:2000, which is carried out at 850 °C.*

However, the tests are not applicable to:

- parts supporting welded connections and parts within a distance of 3 mm of these connections;*
- parts supporting connections in low-power circuits described in Annex H and parts within a distance of 3 mm of these connections;*
- soldered connections on printed circuits boards and parts within a distance of 3 mm of these connections;*
- connections on small components on printed circuit boards, such as diodes, transistors, resistors, inductors, integrated circuits and capacitors, and parts within a distance of 3 mm of these connections.*

K.13.2.201 For **detachable battery packs** or **separable battery packs** with external enclosures of polymeric material that enclose current-carrying parts, the material shall be classified at least V according to IEC 60695-11-10:2013, unless the battery pack has been tested in accordance with K.18.1 a).

Compliance is checked by the relevant tests of IEC 60695-11-10:2013.

NOTE The test of K.18.1 a) is mandatory for exposed battery terminals and is an option for battery terminals that are not exposed.

K.14 Moisture resistance

This clause is not applicable.

K.16 Overload protection of transformers and associated circuits

This clause is not applicable.

K.17 Endurance

This clause is not applicable.

K.18 Abnormal operation

K.18.1 All tools when operating under **battery** power and their **battery** packs shall be so designed that the risk of **fire** or electric shock as a result of abnormal operation is obviated as far as is practical.

Compliance is checked by the following tests.

The abnormal conditions a) to f) below shall be applied.

*The battery tool, **battery** pack and the cords of d) and e), as appropriate, are placed on a soft wood surface covered by two layers of tissue paper; the sample is covered by one layer of untreated 100 % cotton medical gauze. For the tests b), c) and f), the tool is switched on and no additional mechanical load is applied. The test is conducted until failure or until the test sample returns to within 5 K of the ambient temperature or, if neither of these occurs, until at least 3 h has elapsed. A new sample may be used for each fault listed below. No **explosion** shall occur during or after the test. There shall be adequate protection against electric shock as defined in K.9. No charring or burning of the gauze or tissue paper shall result. **Venting** of the **cells** is permitted.*

Charring is defined as a blackening of the gauze caused by combustion. Discolouration of the gauze caused by smoke is acceptable. The resistance for the short in items a), b), d), e) and f) shall not exceed 10 mΩ. Charring or igniting of the tissue paper or gauze from the shorting means is not considered a failure.

*Fuses, **thermal cut-outs**, **thermal links**, **temperature limiters**, electronic devices or any component(s) or conductors(s) that interrupt the discharge current may operate during the above tests. If these devices are relied upon to pass the test, the test is to be repeated two more times, using two additional samples, and shall open the circuit in the same manner, unless the test is otherwise satisfactorily completed. Alternatively, the test may be repeated with the open-circuited device bridged.*

*However, protective **electronic circuits** whose function is relied upon to pass a test shall be regarded as providing a **safety critical function** and comply with 18.8 with a PL = a. If a user adjustable **temperature limiter** operates, the test is conducted with the **temperature limiter** set to the most unfavourable setting and then repeated at this setting with two additional samples.*

- a) *Combinations of exposed terminals of a **detachable battery pack** are shorted so as to produce the worst result. **Battery** pack terminals that can be contacted using either test probe B of IEC 61032:1997 or test probe 13 of IEC 61032:1997 are considered exposed. The means of shorting shall be selected or positioned such that charring or ignition of the tissue paper or gauze is not influenced.*
- b) *The terminals of each motor are shorted one at a time.*
- c) *The rotor of each motor is locked one at a time.*
- d) *Any cord provided between the **separable battery pack** and the battery tool shall be shorted at the point likely to produce the most adverse effects.*
- e) *Any cord provided between the tool and the **charger** shall be shorted at the point likely to produce the most adverse effects.*
- f) *A short is introduced between any two uninsulated parts of opposite polarity not in accordance with the spacings given in Clause K.28 unless this has been evaluated to 18.6. A circuit analysis may be used to determine where a short shall or shall not be applied. The test is not conducted on uninsulated parts that are encapsulated.*

K.18.2 to K.18.5 These subclauses are not applicable.

K.18.8 This subclause does not apply to lithium-ion **charging systems**, since they are covered by K.18.201.

K.18.8.3 to K.18.8.6 These subclauses are not applicable.

K.18.201 Lithium-ion charging systems – abnormal conditions

This subclause applies only to lithium-ion **batteries**.

The **charging system** and **battery** of a lithium-ion system shall be so designed that the risk of **fire** and **explosion** as a result of abnormal operation during charging is obviated as far as is practical.

Compliance is checked by the following test.

*A sample containing the **battery** and the associated assemblies of the **charging system** are placed on a soft wood surface covered by two layers of tissue paper; the sample is covered by one layer of untreated 100 % cotton medical gauze. The **battery system** is operated as specified in K.8.14.2 e) 1) with all of the categories of abnormal conditions listed below in a) to d).*

- a) *Components in the **charging system** are faulted as in 18.6.1 b) to f), one at a time, if the outcome of such a fault is uncertain based upon analysis. For each fault condition introduced, the state of the **battery** before charging is as follows:*
 - *a series configured **battery** shall have a deliberate imbalance. The imbalance is introduced into a **fully discharged battery** by charging one **cell** to approximately 50 % of full charge; or*
 - *if the test of K.12.201 is conducted with an imbalance of less than 50 %, a series configured **battery** shall have a deliberate imbalance as established in K.12.201; or*
 - *a single **cell** or parallel only configuration **battery** shall be **fully discharged**.*
- b) *If the test of K.12.201 is conducted with an imbalance of less than 50 % due to the function of circuit(s), and if a single fault of any component within that circuit(s) is shown to result in the loss of that function, then a series configured **battery** shall be charged with a deliberate imbalance. The imbalance is introduced into a **fully discharged battery** by charging one **cell** to approximately 50 % of full charge.*
- c) *For a **battery** with a series configuration, all **cells** are at approximately 50 % charge, except for one which is shorted. The **battery** is then charged.*
- d) *With a **fully charged battery** connected to the **charger**, a short is introduced to the **charging system** across a component or between adjacent PCB tracks at a location expected to produce the most unfavourable results to evaluate the effect of back-feed from the **battery**. For a **charger** with a cord that connects to the **battery**, the short shall be introduced at the point likely to produce the most adverse effects. The resistance of the short shall not exceed 10 mΩ.*

*During the tests, each **cell** voltage is continuously monitored to determine if it has exceeded the limit condition. **Venting** of the **cells** is permitted.*

The test is conducted until the sample under test experiences a failure, returns to within 5 K of the ambient temperature or, if neither of these, until at least 7 h or twice the normal charge period has elapsed, whichever is longer.

Tests are considered passed if all of the following are true:

- *There has been no **explosion** during the test.*
- *No charring or burning of the gauze or tissue paper has resulted. Charring is defined as a blackening of the gauze caused by combustion. Discolouration of the gauze caused by*

smoke is acceptable. Charring or igniting of the tissue paper or gauze from the shorting means is not considered a failure.

- *The **cells** shall not have exceeded the **upper limit charging voltage** by more than 150 mV or, if they have, then the **charging system** shall be permanently disabled from recharging the **battery**. To determine if recharging is disabled, the **battery** shall be discharged by using the tool tested (in the case of an integral system) or by using a new sample of the tool (in the case of a detachable **battery system**) to approximately 50 % charge, followed by an attempt to recharge the **battery** normally. There shall be no charging current after 10 min or after 25 % of the nominal capacity has been delivered, whichever occurs first.*
- *There shall be no evidence of damage to the **cell** vent to impair compliance with Subclause K.21.202.*

K.18.202 Lithium-ion battery short circuit

This subclause applies only to lithium-ion **batteries**.

There shall be no risk of **fire** or **explosion** when the main discharge connections of a series configured **integral battery**, **detachable battery pack** or **separable battery pack** are shorted under conditions of extreme imbalance.

Compliance is checked by the following test.

*The test is conducted with all the **cells** of the **battery fully charged** and one **cell fully discharged**.*

*A **detachable battery pack** or **separable battery pack** is placed on a soft wood surface covered by two layers of tissue paper and the sample is then covered by one layer of untreated 100 % cotton medical gauze.*

*A tool containing an **integral battery** is placed on a soft wood surface covered by two layers of tissue paper and the sample is then covered by one layer of untreated 100 % cotton medical gauze.*

*The main discharge connections of the **battery** are shorted with a resistance not to exceed 10 m Ω . The test is conducted until the test sample experiences a failure or until the test sample returns to within 5 K of the ambient temperature. There shall be no **explosion** during or after the test. As a result of the test, there shall be no charring or burning of the gauze or tissue paper. **Venting** of **cells** is acceptable.*

Charring is defined as a blackening of the gauze caused by combustion. Discolouration of the gauze caused by smoke is acceptable. Charring or igniting of the tissue paper or gauze from the shorting means is not considered a failure.

*Fuses, **thermal cut-outs**, **thermal links**, **temperature limiters**, electronic devices or any component(s) or conductor(s) that interrupt the discharge current may operate during the above tests. If these devices are relied upon to pass the test, the test is to be repeated two more times, using two additional samples, and shall open the circuit in the same manner, unless the test is otherwise satisfactorily completed. Alternatively, the test may be repeated with the open-circuited device bridged.*

*However, protective **electronic circuits** whose function is relied upon to pass a test shall be regarded as providing a **safety critical function** and comply with 18.8 with a PL = a. If a user adjustable **temperature limiter** operates, the test is conducted with the **temperature limiter** set to the most unfavourable setting and then repeated at this setting with two additional samples.*

K.18.203 Batteries other than lithium-ion – overcharging

Batteries comprised of **cells** other than the lithium-ion type shall withstand abusive overcharging without risk of **fire** or **explosion**.

Compliance is checked by the following test.

*The **battery** is placed on a soft wood surface covered by two layers of tissue paper and the sample is then covered by one layer of untreated 100 % cotton medical gauze and charged at a rate of 10 times the C_5 rate for the **battery** for 1,25 h. There shall be no **explosion** and no charring or burning of the gauze or tissue paper. Charring is defined as a blackening of the gauze caused by combustion. Discolouration of the gauze caused by smoke is acceptable. **Venting** of the **cells** is acceptable.*

K.19 Mechanical hazards

K.19.6 For all tools where the relevant part of IEC 62841-2, IEC 62841-3 or IEC 62841-4 requires the tool to be marked with the **rated no-load speed**, the no-load speed of the spindle at **rated voltage** shall not exceed 110 % of the **rated no-load speed**.

Compliance is checked by the following test.

*The tool is operated for 5 min at no-load. Immediately afterwards, the **battery** is replaced with a **fully charged battery**. The speed of the spindle is then measured after the tool has been operating for 1 min at no-load.*

K.19.201 It shall not be possible to install a **detachable battery pack** or a **separable battery pack** in reverse polarity.

Compliance is checked by inspection.

K.19.202 Lithium-ion enclosure pressure test

This subclause applies only to lithium-ion **batteries**.

An enclosure for lithium-ion **batteries** shall be designed such that it will safely release gasses that may be generated as a result of **venting**.

Compliance is checked by measurement in the case of a) or by the test of b):

- a) *the total area of the openings in the enclosure allowing gasses to pass without obstruction shall be equal to or greater than 20 mm²; or*
- b) *the enclosure shall be tested as follows.*

*A total of 21 ml ± 10 % of air shall be delivered at an initial pressure of 2 070 kPa ± 10 % through a (2,87 ± 0,05) mm diameter orifice to the enclosure of a tool with **integral battery** or the enclosure of a **detachable battery pack** or **separable battery pack**. The pressure within the enclosure shall drop below 70 kPa in 30 s. There shall be no rupturing that would cause the enclosure to fail to meet the requirements of this standard. An additional volume, not to exceed 3 ml, is allowed to be added to the enclosure volume as may be required for test fittings.*

K.20 Mechanical strength

K.20.1 Battery tools and **battery** packs shall have adequate mechanical strength, and shall be so constructed that they withstand rough handling that may be expected.

Compliance is checked by the tests of 20.2 and K.20.3.1 or K.20.3.2.

Following the test, the battery tool and **battery** pack shall not catch **fire** or explode and shall meet the requirements of Clauses K.9, K.19 and either K.18.1 f) or K.28.1.

In addition, the following applies for lithium-ion **batteries** after the test of K.20.3.1 or K.20.3.2:

- the open circuit voltage of the **battery** shall not be less than 90 % of the voltage measured immediately prior to the test;
- the **battery** shall demonstrate normal discharging and recharging after the test;
- there shall be no damage to the **cell** vent that impairs compliance with K.21.202.

K.20.3.1 A hand-held battery tool with any **detachable battery pack** attached is dropped three times in total on a concrete surface from a height of 1 m. For these three drops, the sample is tested in the three most unfavourable positions the lowest point of the tool being 1 m above the concrete surface. For the test, separable **accessories** are not mounted.

For battery tools with **detachable battery packs**, the test is repeated three more times without the **battery** pack attached to the tool. New samples may be used for each series of three drops. For the test, separable **accessories** are not mounted.

In addition for **detachable battery packs** or **separable battery packs**, the test is repeated three more times on the **battery** packs separately.

If **attachments** are provided as specified and mounted in accordance with 8.14.2, the test is repeated with each **attachment** or combination of **attachments** mounted to a separate tool sample with a **detachable battery pack** or **separable battery pack** installed.

K.20.3.2 A **battery-operated transportable tool** with any **detachable battery pack** attached, placed in its normal operating position, is impacted with a smooth steel sphere having a diameter of (50 ± 2) mm and weighing $(0,55 \pm 0,03)$ kg. If a part of the tool can be impacted from above, the sphere is dropped from a rest position to strike the component. Otherwise, the sphere is suspended by a cord and is allowed to fall from a rest position as a pendulum to strike the area of the tool to be tested. In either case, the vertical travel of the sphere is $(1,3 \pm 0,1)$ m.

A **guard** that becomes disassembled is acceptable, if it can be reassembled readily to function properly.

Deformation of a **guard** or other part is acceptable, if the part can be readily restored to its original shape.

Damage to the tool or a portion of the drive system, other than a **guard** is acceptable, if the tool is incapable of **normal operation**.

In addition for **detachable battery packs** or **separable battery packs** with a mass greater than or equal to 3 kg the test is repeated on the **battery** packs separately.

In addition for **detachable battery packs** or **separable battery packs** with a mass less than 3 kg, the **battery** pack shall withstand being dropped three times on a concrete surface from a height of 1 m. The sample shall be positioned to vary the point of impact.

K.20.4 This subclause is not applicable.

K.21 Construction

K.21.5 This subclause is not applicable.

K.21.6 This subclause is not applicable.

K.21.7 to K.21.15 These subclauses are not applicable.

K.21.17.1.2 *Modification:*

The number of cycles is 6 000.

K.21.21 This subclause is not applicable.

K.21.25 to K.21.29 These subclauses are not applicable.

K.21.31 to K.21.34 These subclauses are not applicable.

K.21.201 Tools shall not readily accept **general purpose batteries** (either primary or rechargeable) as an energy source for their primary function.

Compliance is checked by inspection.

K.21.202 Vents of lithium-ion **cells** shall not be obstructed in such a way as to defeat their operation if **venting** is relied upon for safety.

*Compliance is checked by inspection or, if in doubt, by inspecting the **cells** after conclusion of the abnormal tests of K.18.1 a), b) and c) to ensure that **cells** have not vented by any means other than through the **cell vent**.*

K.21.203 User accessible interfaces between elements of a lithium-ion **battery system** shall not employ connectors of the following types:

- standard mains inlet connectors, except for mains supply connections;
- barrel connectors with outside diameters of 6,5 mm or less;
- phone plugs with a diameter of 3,5 mm or less.

Compliance is checked by inspection.

K.22 Internal wiring

K.22.2 This subclause is applicable only for **hazardous voltages**.

K.22.3 This subclause is not applicable.

K.22.6 *Replacement of the last paragraph:*

After the test, the tool shall comply with Clause K.9.

K.23 Components

K.23.1.2 This subclause is not applicable.

K.23.1.9 This subclause is not applicable.

K.23.1.10 Power switches shall have adequate breaking capacity.

*Compliance is checked by subjecting a switch to 50 operation cycles of making and breaking the locked output mechanism current of the **fully charged** battery-operated tool. Each “on” period having a duration of not more than 0,5 s and each “off” period having a duration of at least 10 s.*

*After this test the **power switch** shall have no electrical or mechanical failure. If the switch operates properly in the “on” and “off” positions at the end of the test, it is considered to have no mechanical or electrical failure.*

K.23.1.10.1 to K.23.1.10.3 These subclauses are not applicable.

K.23.1.201 Power switches shall withstand, without excessive wear or other harmful effect, the mechanical, electrical, and thermal stresses occurring in the tool.

*Compliance is checked by subjecting a switch to 6 000 cycles of operation making and breaking the current encountered in the **fully charged** battery tool operated at no-load. The switch is operated at a uniform rate of 30 operations per minute. During the test the switch shall operate correctly. After this test, the **power switch** shall have no electrical or mechanical failure. If the switch operates properly in the “on” and “off” positions at the end of the test, it is considered to have no mechanical or electrical failure.*

K.23.5 This subclause is not applicable.

K.23.201 Cells employed in tools or **cells** employed in **battery** packs shall comply with IEC 62133.

NOTE The above requirement for testing according to IEC 62133 does not include the **battery** pack itself.

K.23.202 Rechargeable **cells** employed in tools or in **battery** packs shall not be of lithium-metal type.

Compliance is checked by inspection.

NOTE Lithium-ion **cells** are not lithium metal **cells**.

K.24 Supply connection and external flexible cords

This clause is not applicable, except as follows:

K.24.201 For battery tools with **separable battery packs**, the external flexible cable or cord shall have anchorages such that the conductors are relieved from strain, including twisting, where they are connected within the tool, and protected from abrasion.

Compliance is checked by inspection.

K.25 Terminals for external conductors

This clause is not applicable.

K.26 Provision for earthing

This clause is not applicable.

K.27 Screws and connections

K.27.1 This subclause is applicable except as follows: the sixth paragraph and the accompanying note, which refers to earthing connections, are not applicable.

K.28 Creepage distances, clearances and distances through insulation

K.28.1 Creepage distances and clearances shall not be less than the values in millimetres shown in Table K.1. The **clearances** specified do not apply to the air gap between the contacts of thermal controls, overload protection devices, switches of micro-gap construction, and the like, or to the air gap between the current-carrying members of such devices where the **clearances** vary with the movement of the contacts. **Creepage distances and clearances** also do not apply to the construction of **battery cells** or the interconnections between **cells** in a **battery** pack. The values specified in Table K.1 do not apply to cross-over points of motor windings.

The values in Table K1 are equal or larger than the values required by IEC 60664-1, when

- an overvoltage category II;
- a material group III;
- a pollution degree 1 for parts protected against deposition of dirt and for lacquered or enamelled windings;
- a pollution degree 3 for other parts;
- inhomogeneous electric field

are applied.

For parts of different polarity, **clearance** and **creepage distances** less than those given in Table K.1 are acceptable if the shorting of the two parts does not result in the tool starting.

NOTE 1 The risk of **fire** due to spacings below the required values is covered by the requirements of 18.1.

**Table K.1 – Minimum creepage distances and clearances
between parts of opposite polarity**

Dimensions in millimetres

Working voltage ≤ 15 V		Working voltage > 15 V and ≤ 32 V		Working voltage > 32 V	
Creepage distance	Clearance	Creepage distance	Clearance	Creepage distance	Clearance
0,8 ^a	0,8	1,5	1,5	2,0 ^a	1,5
^a These creepage distances are slightly lower than suggested by IEC 60664-1. Creepage distances between live parts of different polarity (functional insulation) are only associated to fire hazard, not to electric shock hazard. As products in the scope of IEC 62841 are products supervised during normal use , lower distances are justified.					

For parts having a **hazardous voltage** between them, the sum total of the measured distances between each of these parts and their nearest accessible surface shall not be less than 1,5 mm **clearance** and 2,0 mm **creepage distance**.

NOTE 2 Figure K.1 provides clarification on the measurement method.

Compliance is checked by measurement.

*The way in which **creepage distances** and **clearances** are measured is indicated in Annex A.*

Distances through slots or openings in external parts of insulating material are measured to the metal foil in contact with the accessible surface; the foil is pushed into corners and the like by means of the standard test probe B of IEC 61032:1997, but is not pressed into openings.

*The sum total of distances measured between parts operating at **hazardous voltage** and accessible surfaces is determined by measuring the distance from each part to the accessible surface. The distances are to be added together to determine the sum total. See Figure K.1. For the purpose of this determination, one of the distances shall be 1,0 mm or greater. See Annex A, cases 1 to 10.*

*If necessary, a force is applied to any point on bare conductors and to the outside of metal enclosures, in an endeavour to reduce the **creepage distances** and **clearances** while taking the measurements.*

The force is applied by means of the test probe B of IEC 61032:1997 and has a value of:

- 2 N for bare conductors;
- 30 N for enclosures.

Means provided for fixing the tool to a support are considered to be accessible.

K.28.2 This subclause is not applicable.

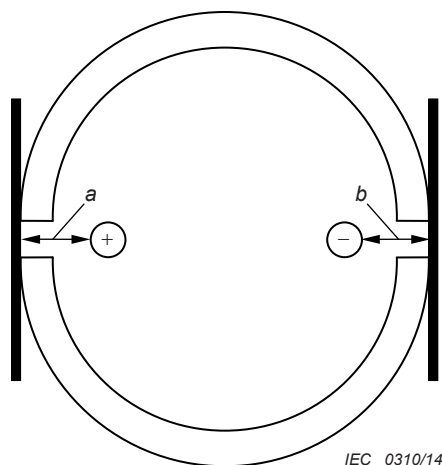

Dimension a = distance from positive bare conductive part to the external surface as defined by foil stretched across the openings.

Dimension b = distance from negative bare conductive part to the external surface as defined by foil stretched across the openings.

$a + b$ is the sum total as defined in K.28.1.

Figure K.1 – Measurement of clearances

Annex L (normative)

Battery tools and battery packs provided with mains connection or non-isolated sources

L.1 Scope

This annex applies to rechargeable battery-powered motor-operated or magnetically driven

- **hand-held tools** (IEC 62841-2);
- **transportable tools** (IEC 62841-3);
- **lawn and garden machinery** (IEC 62841-4);

and the **battery** packs for such tools or machinery that are also operated and/or charged directly from the mains or a **non-isolated source**, including tools provided with integral **battery chargers**. The above listed categories are hereinafter referred to as “tools” or “machines”.

The maximum **rated voltages** for tools are 250 V single phase a.c. or d.c. mains source and 75 V d.c. **battery** source. The maximum **rated voltage** for **battery** packs is 75 V d.c.

Battery packs for tools covered under this annex intended to be charged by a non-isolated **charger** shall be evaluated by this annex and standard. When evaluating a **battery** pack for protection against electric shock, **creepage distances**, **clearances** and distances through insulation, the **battery** pack shall be fitted to the intended **charger**.

Since **battery** packs for power tools are submitted to different use patterns (such as rough use, high charging and discharging currents) their safety can be evaluated only by this annex and not by using other standards for **battery** packs, such as IEC 62133, unless otherwise indicated in this annex. All relevant requirements of IEC 62133 are addressed in this annex.

When evaluating the risk of **fire** associated with **detachable battery packs**, consideration has been given to the fact that these **battery** packs are unattended energy sources and have been evaluated as such in this standard. Requirements in other standards regarding the risk of **fire** due to the charging of these **detachable battery packs** are therefore considered to be fulfilled.

This annex also addresses requirements covering the use of lithium-ion **cells** employed in **battery systems** in tools. The following is considered within the context of these requirements:

- These requirements address the risk of **fire** or **explosion** of these **batteries** and not any possible hazards associated with toxicity nor potential hazards associated with transportation or disposal.

NOTE 1 IEC 62281 covers the safety aspects of lithium-ion batteries during transport.

- **Battery systems** covered by these requirements are not intended to be serviced by the end user.
- These requirements are intended to provide comprehensive evaluation of a **battery** only if used in products covered by this standard.
- These requirements address the safety of lithium-ion **battery systems** during storage and use including discharge and charge. These requirements are only considered to be supplementary requirements in regards to **battery charger** fire and electric shock.
- These requirements refer to and require parameters supplied in reference to the **cells** that establish conditions for safe use of those **cells**. Those parameters form the basis of acceptance criteria for a number of tests contained herein. This standard does not

independently evaluate the safety of **cells**. These parameters, taken as a set, constitute the “**Specified Operating Region**” for a **cell**. There may be several sets of **specified operating region(s)**.

This annex is not intended to apply to tools using **general purpose batteries** installed by the user and this annex alone will not be sufficient to ensure all hazards are considered for these products.

This annex does not apply to the safety of battery **chargers** themselves. However, this annex covers the safe functioning of lithium-ion **battery systems**.

NOTE 2 IEC 60335-2-29 covers a variety of **chargers**.

All clauses of this standard apply unless otherwise specified in this annex. If a clause is stated in the annex, the requirements replace the requirements of the main body of the standard unless otherwise specified.

L.3 Terms and definitions

This clause is applicable except as follows:

For the purpose of this annex, the following additional definitions apply:

L.3.201

battery system

combination of a lithium-ion **battery**, the **charging system**, the tool and the interfaces between them as existing during operation of the tool or during charging

L.3.202

cell

basic functional electrochemical unit containing an assembly of electrodes, electrolyte, container, terminals, and usually separators, that is a source of electrical energy by direct conversion of chemical energy

L.3.203

charger

part or all of the **charging system** contained in a separate enclosure. As a minimum, the **charger** includes some of the power conversion circuitry. Not all **charging systems** include a separate **charger** as in the case where a tool may be charged utilizing a mains **supply cord** or may incorporate a plug for attachment to a mains receptacle

L.3.204

charging system

combination of circuitry intended to charge, balance and/or maintain the state of charge of the **battery**

L.3.205

C₅ rate

current, in amperes, that a **cell** or **battery** can be discharged at for 5 h to the voltage cut-off point specified by the **cell** manufacturer

L.3.206

detachable battery pack

battery which is contained in a separate enclosure from the battery tool and is intended to be removed from the tool for charging purposes

L.3.207**fire**

emission of flames from a **battery**

L.3.208**fully charged (battery/cell)**

cell or **battery** charged to the maximum state of charge permitted by the **battery charging system** intended for use with the tool

L.3.209**fully discharged (battery/cell)**

battery or **cell** that has been discharged at **C₅ rate** until one of the following conditions occurs: discharge terminates due to protective circuitry or the **battery** (or **cell**) reaches a total voltage with an average voltage per cell equal to the end-of-discharge voltage for the cell chemistry being used unless a different end-of-discharge voltage is specified by the manufacturer

Note 1 to entry: The end-of-discharge voltages for common cell chemistries are provided in L.5.210.

L.3.210**general purpose (battery/cell)**

batteries and **cells** available from a variety of manufacturers, through a variety of outlets intended for a variety of different manufacturers' products

Note 1 to entry: 12 V automotive **batteries** and AA, C and D alkaline **cells** are examples of **general purpose**.

L.3.211**hazardous voltage**

voltage between parts having an average value exceeding 60 V d.c. or exceeding 42,4 V peak when the peak-to-peak ripple exceeds 10 % of the average value

L.3.212**integral battery**

battery which is contained within the battery tool and is not removed from the battery tool for charging purposes

Note 1 to entry: A **battery** that is to be removed from the battery tool for disposal or recycling purposes only is considered to be an **integral battery**.

L.3.213**maximum charging current**

highest current that a lithium-ion **cell** is permitted to pass during charging for a specified range of temperatures as specified by the **cell** manufacturer and evaluated in accordance with IEC 62133.

L.3.214**separable battery pack**

battery which is contained in a separate enclosure from the battery tool and is connected to the battery tool by a cord

L.3.215**specified operating region**

range of permissible operation of lithium-ion **cells**, expressed by **cell** parameter limits

L.3.215.1**specified operating region for charging**

conditions for voltage and current during charging in which the lithium-ion **cell** is permitted to operate as specified by the **cell** manufacturer and evaluated in accordance with IEC 62133

L.3.216

upper limit charging voltage

highest voltage that a lithium-ion **cell** is permitted to attain during normal charging for a specified range of temperatures as specified by the **cell** manufacturer and evaluated in accordance with IEC 62133

L.3.217

venting

condition that occurs, when a **cell** releases excessive internal pressure intended by design to preclude **explosion**

L.5 General conditions for the tests

L.5.2 Addition:

*The cumulative stress resulting from successive tests on the **battery** is to be avoided. Additional samples may be used as necessary.*

L.5.7.2 Unless otherwise specified, tests to be done at **rated voltage** are done with a **fully charged battery**.

L.5.201 *When measuring voltage, the peak value of any superimposed ripple exceeding 10 % of the average value shall be included. Transient voltages are ignored, such as a temporary increase of voltage, for example after the **battery** pack is removed from the **charger**.*

L.5.202 *Measurements of **cell** voltages during the tests of lithium-ion systems shall be made using a single pole resistive-capacitive low pass filter with a cut-off frequency of 5 KHz \pm 500 Hz. If charging voltage limits have been exceeded, the peak value of the voltage measured after this network shall be used. The measurement shall have measurement tolerance within \pm 1 %.*

L.5.203 *Some of the tests may result in **fire** or **explosion**. It is therefore important that personnel be protected from the flying fragments, explosive force, sudden release of heat, chemical burns, intense light and noise that may result from such **explosions**. The test area is to be well ventilated to protect personnel from possible harmful fumes or gases.*

L.5.204 *Unless otherwise specified, all **batteries** shall be fully conditioned as follows: **batteries** shall be **fully discharged** and then charged in accordance with the manufacturer's instructions. The sequence shall be repeated one more time with an interval of at least two hours after each discharge.*

L.5.205 *The location of thermocouples for lithium-ion **cell** temperature measurements shall be on the outer surface, half way along the longest dimension, of the **cell** that results in the highest temperature.*

L.5.206 *Currents measured during **battery** charging shall be average currents with an averaging period of 1 s to 5 s.*

L.5.207 *If not otherwise specified, a **fully charged battery** shall be used. After removal from the **charging system** and before starting a test, the **fully charged battery** shall be allowed to rest for at least 2 h but no more than 6 h at an ambient temperature of (20 ± 5) °C.*

L.5.208 *When a **battery** comprising of a single **cell** is employed, instructions in this standard referring to special preparations of a **cell** in a series configuration shall be ignored.*

L.5.209 For **battery** designs where there is a series arrangement of parallel clusters of **cells**, the cluster shall be treated as a single **cell** for those tests that require altering the amount of charge on a single **cell** prior to conducting the test.

L.5.210 The end-of-discharge voltages for common cell chemistries are:

- 0,9 V/cell for nickel cadmium or nickel metal-hydride **batteries**;
- 1,75 V/cell for lead-acid **batteries**;
- 2,5 V/cell for lithium-ion **batteries**, unless the manufacturer specifies a different voltage.

L.7 Classification

L.7.1 This subclause applies except that **class III tools** are not considered in this annex.

L.8 Marking and instructions

L.8.1 Non-isolated sources that can supply a tool, or tools that can be supplied directly from the mains, shall be marked with the following:

- **rated voltage(s)** or **rated voltage range(s)**, in volts;
- symbol for nature of supply, unless the **rated frequency(ies)** or **rated frequency range** is marked. The symbol for nature of supply shall be placed next to the marking for **rated voltage**;
- **rated input**, in watts, or **rated current** in amperes;
- symbol for **class II construction**, for **class II tools** only.

Compliance is checked by inspection.

L.8.3 Tools and **detachable battery packs** or **separable battery packs** shall be marked with additional information as follows:

- the business name and address of the manufacturer and, where applicable, his authorised representative. Any address shall be sufficient to ensure contact. Country or state, city and postal code (if any) are deemed sufficient for this purpose;
- designation of series or type, allowing the technical identification of the product. This may be achieved by a combination of letters and/or numbers and may be combined with the designation of tool.

NOTE 1 The term “designation of series or type” is also known as model number.

Tools shall also be marked with additional information as follows:

- the year of manufacture and a date code of identifying at least the month of manufacture;
- designation of the tool:
designation of the tool may be achieved by a code that is any combination of letters, numbers or symbols providing that this code is explained by giving the explicit designation such as “drill”, “planer” etc. in the instructions supplied with the tool;

NOTE 2 An example of such code is “A123-B”.

- for tools manufactured such that its parts are shipped separately for assembly by the end user each part shall be marked with a distinct identification on the part or the package.

Separable and **detachable battery packs** shall also be marked with additional information as follows:

- the capacity assigned by the manufacturer in Ah or mAh, based on the rated capacity of the cells determined in accordance with IEC 61056-1, IEC 61960, IEC 61951-1 and IEC 61951-2, as applicable;
- for alkaline or other non-acid electrolyte **batteries**, the type of **battery** such as Li-Ion, NiCd and NiMH.

If additional markings are used, they shall not give rise to misunderstanding.

Compliance is checked by inspection.

L.8.4 Markings specified in L.8.1, 8.2 and L.8.3 shall not be on a **detachable part** of the tool.

Markings specified in 8.2 shall be clearly discernible from the outside of the tool. Markings specified in L.8.3 shall be visible with any **separable battery pack** or **detachable battery pack** removed. Other markings on the tool may be visible after removal of a cover, if necessary.

Indications for switches and controls shall be placed on or in the vicinity of these components; they shall not be placed on parts which can be repositioned, or positioned in such a way that the marking is misleading.

Compliance is checked by inspection.

L.8.14.1.1 This subclause is applicable except as follows:

Item 5) Service, is replaced by the following:

5) Battery tool use and care

- Recharge only with the charger specified by the manufacturer.** *A charger that is suitable for one type of battery pack may create a risk of fire when used with another battery pack.*
- Use power tools only with specifically designated battery packs.** *Use of any other battery packs may create a risk of injury and fire.*
- When battery pack is not in use, keep it away from other metal objects, like paper clips, coins, keys, nails, screws or other small metal objects, that can make a connection from one terminal to another.** *Shorting the battery terminals together may cause burns or a fire.*
- Under abusive conditions, liquid may be ejected from the battery; avoid contact. If contact accidentally occurs, flush with water. If liquid contacts eyes, additionally seek medical help.** *Liquid ejected from the battery may cause irritation or burns.*
- Do not use a battery pack or tool that is damaged or modified.** *Damaged or modified batteries may exhibit unpredictable behaviour resulting in fire, explosion or risk of injury.*
- Do not expose a battery pack or tool to fire or excessive temperature.** *Exposure to fire or temperature above 130 °C may cause explosion.*

NOTE The temperature „130 °C“ can be replaced by the temperature „265 °F“.

- Follow all charging instructions and do not charge the battery pack or tool outside the temperature range specified in the instructions.** *Charging improperly or at temperatures outside the specified range may damage the battery and increase the risk of fire.*

6) Service

- Have your power tool serviced by a qualified repair person using only identical replacement parts.** *This will ensure that the safety of the power tool is maintained.*
- Never service damaged battery packs.** *Service of battery packs should only be performed by the manufacturer or authorized service providers.*

L.8.14.2 This subclause is applicable except as follows:

Addition:

e) For battery tools:

- 1) Instructions regarding **battery** charging, information regarding ambient temperature range for tool and **battery** use and storage, and the recommended ambient temperature range for the charging system during charging;
- 2) For a **battery**-operated tool intended for use with a **detachable battery pack** or a **separable battery pack**: instructions indicating the appropriate **battery** packs for use, such as by a catalog number, series identification or the equivalent;
- 3) Instructions indicating the appropriate **charger** for use, such as by a catalog number, series identification or the equivalent.

☐ Z1) For battery tools with **integral battery**: instruction, how the **integral battery** can be removed safely from the tool after the tool's end of life, and information about the type of **battery** such as Li-Ion, NiCd and NiMH. ☐

L.9 Protection against electric shock

NOTE The title of this clause differs from that of the main standard.

The requirements of 9.1 through 9.4 apply for all conditions along with the following addition:

Addition:

Tools covered by this annex and their **battery** packs shall be so constructed and enclosed that there is adequate protection against electric shock.

The clause of the standard applies to tools when they are connected to the mains or are supplied by a **non-isolated source**. During the evaluation in this condition, **battery** packs are to be connected to the tool in the normal fashion. The tool is also evaluated with the **battery** pack removed if such removal can be accomplished without the use of a tool.

L.9.201 For **battery** packs which may be disconnected from the tool and tools operated under **battery** power it shall not be possible to have two conductive, simultaneously **accessible parts** where the voltage between them is hazardous, unless they are provided with **protective impedance**.

In the case of **protective impedance**, the short circuit current between the parts shall not exceed 2 mA for d.c. or 0,7 mA peak for a.c. and there shall not be more than 0,1 μ F capacitance directly between the parts.

Compliance for accessibility is checked by applying the test probe B of IEC 61032:1997 to each conductive part.

The test probe B of IEC 61032:1997 is applied with a force not exceeding 5 N through openings to any depth that the test probe will permit, and it is rotated or angled before, during and after insertion to any position.

If the opening does not allow the entry of the probe, a rigid test probe with the dimensions of the test probe B of IEC 61032:1997, but without any articulation, is used, the force on the probe is increased to 20 N and the test with the articulated test probe B of IEC 61032:1997 repeated.

Contact with the test probe is determined with all **detachable parts** removed and the battery tool operated in any possible position of **normal use**.

Lamps located behind detachable covers are not removed, providing the lamp may be de-energized by means of a user operable plug, **battery disconnection** or a switch.

L.10 Starting

This clause only applies when the tool is in the configuration where it is directly connected to the mains or to a **non-isolated source**.

L.11 Input and current

This clause only applies when the tool is in the configuration where it is directly connected to the mains or to a **non-isolated source**. In the case of tools that can also charge the **battery** while performing their intended function, the test is conducted while charging a previously discharged **battery** pack.

L.12 Heating

This clause only applies when the tool is in the configuration where it is directly connected to the mains or to a **non-isolated source**. In the case of tools that can also charge the **battery** while performing their intended function, they are tested with the **charger** connected and are operated at no-load until the tool stops operating due to the **battery** being discharged or until thermal stabilization is achieved, whichever occurs first. The test is repeated, allowing the **battery** to charge while the tool is not operating.

L.12.201 Normal charging of lithium-ion systems

Charging a lithium-ion **battery** under normal conditions shall not exceed the **specified operating region for charging** of the cell.

Compliance is checked by the following tests.

*The **battery** is charged in accordance with the **charging system** instructions starting with a **fully discharged battery**. Testing is carried out at an ambient temperature of $(20 \pm 5) ^\circ\text{C}$ and*

- if the tool is recommended to be operated at a minimum temperature lower than $4 ^\circ\text{C}$, the test is also conducted at that minimum temperature ${}^0_{-5} \text{K}$;*
- if the tool is recommended to be operated at a maximum temperature greater than $40 ^\circ\text{C}$, the test is also conducted at that maximum temperature ${}^{+5}_{-0} \text{K}$.*

*For all individual **cells**, the voltage, the temperature measured in accordance with L.5.205 and the charging current are monitored. In the case of parallel configurations, analysis may be used to avoid measuring the individual branch currents. The result shall not exceed their **specified operating region for charging** (e.g. limits of voltage and current dependant on the temperature).*

NOTE 1 The following is an example result of such analysis: the charging current for each branch of a parallel connection would not need to be monitored, if the maximum deliverable current of the **charger** did not exceed the **maximum charging current** of a single cell.

*For **batteries** employing series configurations, the test is repeated with a deliberately imbalanced **battery**. The imbalance is introduced into a **fully discharged battery** by charging one **cell** to approximately 50 % of full charge.*

*If it can be demonstrated through testing and/or design evaluation that an imbalance less than 50 % would actually occur in **normal use**, then this lower imbalance may be used.*

NOTE 2 Examples are those designs that employ circuitry intended for maintaining balance between **cells** in the **battery** pack. Systems with a small number of **cells** in series may be shown to exhibit limited imbalance in practice, if the product ceases to operate with a **battery** prepared with a smaller initial imbalance.

NOTE 3 An example for a testing is repeated charging and discharging a **battery** in accordance with the manufacturer's instructions until its capacity has decreased to 80 % of the rated capacity, using the imbalance at the end of the test.

L.13 Resistance to heat and fire

This clause is applicable except as follows:

L.13.1 Addition:

This subclause only applies when the tool is in the configuration where it is directly connected to the mains or to a **non-isolated source**.

In the case of tools that can charge the **battery** while performing their intended function, the **battery** pack shall be evaluated with the **charger** connected to the mains and with a **battery** in a condition that results in the most unfavourable temperatures.

In addition, tools capable of charging the **battery** and which may also be capable of performing its intended operation shall also be evaluated with **battery** power alone if this may create temperatures that are more unfavourable. For the purposes of L.13.1, a part that is energized only by a **battery** source is not to be considered live.

L.13.2 Addition:

*Non-metallic parts of a **detachable battery pack** or **separable battery pack** or non-metallic parts of a tool that contains an **integral battery** supporting connections that carry a current exceeding 0,2 A during charging and non-metallic parts within a distance of 3 mm of such connections, are subjected to the glow-wire test of IEC 60695-2-11:2000, which is carried out at 850 °C.*

However, the tests are not applicable to:

- *parts supporting welded connections and parts within a distance of 3 mm of these connections;*
- *parts supporting connections in low-power circuits described in Annex H and parts within a distance of 3 mm of these connections;*
- *soldered connections on printed circuits boards and parts within a distance of 3 mm of these connections;*
- *connections on small components on printed circuit boards, such a diodes, transistors, resistors, inductors, integrated circuits and capacitors, and parts within a distance of 3 mm of these connections.*

L.14 Moisture resistance

This clause only applies when the tool is in the configuration where it is directly connected to the mains or to a **non-isolated source**.

L.16 Overload protection of transformers and associated circuits

This clause only applies when the tool is in the configuration where it is directly connected to the mains or to a **non-isolated source**.

L.17 Endurance

This clause applies to tools capable of continuous operation when they are supplied directly from the mains or from a **non-isolated source**. Tools that are not capable of continuous operation shall be operated under **battery** power for the duration of the test but shall be evaluated for electric strength with their **charger** connected.

L.18 Abnormal operation

This clause, except L.18.8 and L.18.201 to L.18.204, only applies when the tool is in the configuration where it is directly connected to the mains or to a **non-isolated source**.

L.18.8 This subclause does not apply to lithium-ion **charging systems**, since they are covered by L.18.202.

L.18.201 All tools when operating only under **battery** power and their **battery** packs shall be so designed that the risk of **fire** or electric shock as a result of abnormal operation is obviated as far as is practical.

Compliance is checked by the following tests.

The abnormal conditions a) to f) below shall be applied.

*The battery tool, **battery** pack and the cords of d) and e), as appropriate, are placed on a soft wood surface covered by two layers of tissue paper; the sample is covered by one layer of untreated 100 % cotton medical gauze. For the tests b), c) and f), the tool is switched on and no additional mechanical load is applied. The test is conducted until failure or until the test sample returns to within 5 K of the ambient temperature or, if neither of these occurs, until at least 3 h has elapsed. A new sample may be used for each fault listed below. No **explosion** shall occur during or after the test. There shall be adequate protection against electric shock as defined in Clause L.9. No charring or burning of the gauze or tissue paper shall result. **Venting** of the **cells** is permitted.*

Charring is defined as a blackening of the gauze caused by combustion. Discolouration of the gauze caused by smoke is acceptable. The resistance for the short in items a), b), d), e) and f) shall not exceed 10 mΩ. Charring or igniting of the tissue paper or gauze from the shorting means is not considered a failure.

*Fuses, **thermal cut-outs**, **thermal links**, **temperature limiters**, electronic devices or any component(s) or conductor(s) that interrupt the discharge current may operate during the above tests. If these devices are relied upon to pass the test, the test is to be repeated two more times, using two additional samples, and shall open the circuit in the same manner, unless the test is otherwise satisfactorily completed. Alternatively, the test may be repeated with the open-circuited device bridged.*

*However, protective **electronic circuits** whose function is relied upon to pass a test shall be regarded as providing a **safety critical function** and comply with 18.8 with a PL = a. If a user adjustable **temperature limiter** operates, the test is conducted with the **temperature limiter** set to the most unfavourable setting and then repeated at this setting with two additional samples.*

- a) *Combinations of exposed terminals of a **detachable battery pack** are shorted so as to produce the worst result. **Battery** pack terminals that can be contacted using either test probe B of IEC 61032:1997 or test probe 13 of IEC 61032:1997 are considered exposed. The means of shorting shall be selected or positioned such that charring or ignition of the tissue paper or gauze is not influenced.*
- b) *The terminals of each motor are shorted one at a time.*

- c) *The rotor of each motor is locked one at a time.*
- d) *Any cord provided between the **separable battery pack** and the battery tool shall be shorted at the point likely to produce the most adverse effects.*
- e) *Any cord provided between the tool and the **charger** shall be shorted at the point likely to produce the most adverse effects.*
- f) *A short is introduced between any two uninsulated parts of opposite polarity not in accordance with the spacings given in L.28.201 unless this has been evaluated to 18.6. A circuit analysis may be used to determine where a short shall or shall not be applied. The test is not conducted on uninsulated parts that are encapsulated.*

L.18.202 Lithium-ion charging systems – abnormal conditions

This subclause applies only to lithium-ion **batteries**.

The **charging system** and **battery** of a lithium-ion system shall be so designed that the risk of **fire** and **explosion** as a result of abnormal operation during charging is obviated as far as is practical.

Compliance is checked by the following test.

*A sample containing the **battery** and the associated assemblies of the **charging system** are placed on a soft wood surface covered by two layers of tissue paper; the sample is covered by one layer of untreated 100 % cotton medical gauze. The **battery system** is operated as specified in L.8.14.2 e)1) with all of the categories of abnormal conditions listed below in a) to d).*

- a) *Components in the **charging system** are faulted as in 18.6.1 b) to f), one at a time, if the outcome of such a fault is uncertain based upon analysis. For each fault condition introduced, the state of the **battery** before charging is as follows:*
 - *a series configured **battery** shall have a deliberate imbalance. The imbalance is introduced into a **fully discharged battery** by charging one **cell** to approximately 50 % of full charge; or*
 - *if the test of L.12.201 is conducted with an imbalance of less than 50 %, a series configured **battery** shall have a deliberate imbalance as established in L.12.201; or*
 - *a single **cell** or parallel only configuration **battery** shall be **fully discharged**.*
- b) *If the test of L.12.201 is conducted with an imbalance of less than 50 % due to the function of circuit(s), and if a single fault of any component within that circuit(s) is shown to result in the loss of that function, then a series configured **battery** shall be charged with a deliberate imbalance. The imbalance is introduced into a **fully discharged battery** by charging one **cell** to approximately 50 % of full charge.*
- c) *For a **battery** with a series configuration, all **cells** are at approximately 50 % charge, except for one which is shorted. The **battery** is then charged.*
- d) *With a **fully charged battery** connected to the **charger**, a short is introduced to the **charging system** across a component or between adjacent PCB tracks at a location expected to produce the most unfavourable results to evaluate the effect of back-feed from the **battery**. For a **charger** with a cord that connects to the **battery**, the short shall be introduced at the point likely to produce the most adverse effects. The resistance of the short shall not exceed 10 mΩ.*

*During the tests, each **cell** voltage is continuously monitored to determine if it has exceeded the limit condition. **Venting** of the **cells** is permitted.*

The test is conducted until the sample under test experiences a failure, returns to within 5 K of the ambient temperature or, if neither of these, until at least 7 h or twice the normal charge period has elapsed, whichever is longer.

Tests are considered passed if all of the following are true:

- There has been no **explosion** during the test.
- No charring or burning of the gauze or tissue paper has resulted. Charring is defined as a blackening of the gauze caused by combustion. Discolouration of the gauze caused by smoke is acceptable. Charring or igniting of the tissue paper or gauze from the shorting means is not considered a failure.
- The **cells** shall not have exceeded the **upper limit charging voltage** by more than 150 mV or, if they have, then the **charging system** shall be permanently disabled from recharging the **battery**. To determine if recharging is disabled, the **battery** shall be discharged by using the tool tested (in the case of an integral system) or by using a new sample of the tool (in the case of a detachable **battery system**) to approximately 50 % charge, followed by an attempt to recharge the **battery** normally. There shall be no charging current after 10 min or after 25 % of the nominal capacity has been delivered, whichever occurs first.
- There shall be no evidence of damage to the **cell** vent to impair compliance with Subclause L.21.202.

L.18.203 Lithium-ion battery short circuit

This subclause applies only to lithium-ion **batteries**.

There shall be no risk of **fire** or **explosion** when the main discharge connections of a series configured **integral battery**, **detachable battery pack** or **separable battery pack** are shorted under conditions of extreme imbalance.

Compliance is checked by the following test.

The test is conducted with all the **cells** of the **battery fully charged** and one **cell fully discharged**.

A **detachable battery pack** or **separable battery pack** is placed on a soft wood surface covered by two layers of tissue paper and the sample is then covered by one layer of untreated 100 % cotton medical gauze.

A tool containing an **integral battery** is placed on a soft wood surface covered by two layers of tissue paper and the sample is then covered by one layer of untreated 100 % cotton medical gauze.

The main discharge connections of the **battery** are shorted with a resistance not to exceed 10 m Ω . The test is conducted until the test sample experiences a failure or until the test sample returns to within 5 K of the ambient temperature. There shall be no **explosion** during or after the test. As a result of the test, there shall be no charring or burning of the gauze or tissue paper. **Venting** of **cells** is acceptable.

Charring is defined as a blackening of the gauze caused by combustion. Discolouration of the gauze caused by smoke is acceptable. Charring or igniting of the tissue paper or gauze from the shorting means is not considered a failure.

Fuses, **thermal cut-outs**, **thermal links**, **temperature limiters**, electronic devices or any component(s) or conductor(s) that interrupt the discharge current may operate during the above tests. If these devices are relied upon to pass the test, the test is to be repeated two more times, using two additional samples, and shall open the circuit in the same manner, unless the test is otherwise satisfactorily completed. Alternatively, the test may be repeated with the open-circuited device bridged.

However, protective **electronic circuits** whose function is relied upon to pass a test shall be regarded as providing a **safety critical function** and comply with 18.8 with a PL = a. If a user

*adjustable **temperature limiter** operates, the test is conducted with the **temperature limiter** set to the most unfavourable setting and then repeated at this setting with two additional samples.*

L.18.204 Batteries other than lithium-ion – overcharging

Batteries comprised of **cells** other than the lithium-ion type shall withstand abusive overcharging without risk of **fire** or **explosion**.

Compliance is checked by the following test.

*The **battery** is placed on a soft wood surface covered by two layers of tissue paper and the sample is then covered by one layer of untreated 100 % cotton medical gauze and charged at a rate of 10 times the **C₅ rate** for the **battery** for 1,25 h. There shall be no **explosion** and no charring or burning of the gauze or tissue paper. Charring is defined as a blackening of the gauze caused by combustion. Discolouration of the gauze caused by smoke is acceptable. **Venting** of the **cells** is acceptable.*

L.19 Mechanical hazards

L.19.201 It shall not be possible to install a **detachable battery pack** or a **separable battery pack** in reverse polarity.

Compliance is checked by inspection.

L.19.202 Lithium-ion enclosure pressure test

This subclause applies only to lithium-ion **batteries**.

An enclosure for lithium-ion **batteries** shall be designed such that it will safely release gasses that may be generated as a result of **venting**.

Compliance is checked by measurement in the case of a) or by the test of b):

- a) *the total area of the openings in the enclosure allowing gasses to pass without obstruction shall be equal to or greater than 20 mm²; or*
- b) *the enclosure shall be tested as follows.
A total of 21 ml ± 10 % of air shall be delivered at an initial pressure of 2 070 kPa ± 10 % through a (2,87 ± 0,05) mm diameter orifice to the enclosure of a tool with **integral battery** or the enclosure of a **detachable battery pack** or **separable battery pack**. The pressure within the enclosure shall drop below 70 kPa in 30 s. There shall be no rupturing that would cause the enclosure to fail to meet the requirements of this standard. An additional volume, not to exceed 3 ml, is allowed to be added to the enclosure volume as may be required for test fittings.*

L.20 Mechanical strength

This clause, except L.20.201 and L.20.202, only applies when the tool is in the configuration where it is directly connected to the mains or to a **non-isolated source**.

L.20.201 With the **battery** connected, battery tools and **battery** packs shall have adequate mechanical strength, and shall be so constructed that they withstand rough handling that may be expected.

Compliance is checked by the tests of 20.2 and L.20.202.

Following the test, the battery tool and **battery** pack shall not catch **fire** or explode and shall meet the requirements of Clauses L.9, L.19, L.28.1 and either L.18.201 f) or L.28.201.

In addition, the following applies for lithium-ion **batteries** after the test of L.20.202:

- the open circuit voltage of the **battery** shall not be less than 90 % of the voltage measured immediately prior to the test;
- the **battery** shall demonstrate normal discharging and recharging after the test;
- there shall be no damage to the **cell** vent that impairs compliance with L.21.202.

L.20.202 For hand-held battery tools, L.20.202.1 applies. For transportable battery tools, L.20.202.2 applies.

L.20.202.1 A hand-held battery tool with any **detachable battery pack** attached, shall withstand being dropped three times on a concrete surface from a height of 1 m. For these three drops, the sample is tested in the three most unfavourable positions the lowest point of the tool being 1 m above the concrete surface. For the test, separable **accessories** are not mounted.

For battery tools with **detachable battery packs**, the test is repeated three more times without the **battery** pack attached to the tool. New samples may be used for each series of three drops. For the test, separable **accessories** are not mounted.

In addition for **detachable battery packs** or **separable battery packs** the test is repeated three more times on the **battery** packs separately.

If **attachments** are provided as specified and mounted in accordance with 8.14.2, the test is repeated with each **attachment** or combination of **attachments** mounted to a separate tool sample with a **detachable battery pack** or **separable battery pack** installed.

L.20.202.2 A **battery-operated transportable tool** with any **detachable battery pack** attached, placed in its normal operating position, is impacted with a smooth steel sphere having a diameter of (50 ± 2) mm and weighing $(0,55 \pm 0,03)$ kg. If a part of the tool can be impacted from above, the sphere is dropped from a rest position to strike the component. Otherwise, the sphere is suspended by a cord and is allowed to fall from a rest position as a pendulum to strike the area of the tool to be tested. In either case, the vertical travel of the sphere is $(1,3 \pm 0,1)$ m.

A **guard** that becomes disassembled is acceptable, if it can be reassembled readily to function properly.

Deformation of a **guard** or other part is acceptable, if the part can be readily restored to its original shape.

Damage to the tool or a portion of the drive system, other than a **guard** is acceptable, if the tool is incapable of **normal operation**.

In addition for **detachable battery packs** or **separable battery packs** with a mass greater than or equal to 3 kg the test is repeated on the **battery** packs separately.

In addition for **detachable battery packs** or **separable battery packs** with a mass less than 3 kg, the **battery** pack shall withstand being dropped three times on a concrete surface from a height of 1 m. The sample shall be positioned to vary the point of impact.

L.21 Construction

This clause, except L.21.201 and L.21.202, only applies when the tool is in the configuration where it is directly connected to the mains or to a **non-isolated source**.

L.21.201 Tools shall not readily accept **general purpose batteries** (either primary or rechargeable) as an energy source for their primary function.

Compliance is checked by inspection.

L.21.202 Vents of lithium-ion **cells** shall not be obstructed in such a way as to defeat their operation if **venting** is relied upon for safety.

*Compliance is checked by inspection or, if in doubt, by inspecting the **cells** after conclusion of the abnormal tests of L.18.201 a), b) and c) to ensure that **cells** have not vented by any means other than through the **cell vent**.*

L.21.203 User accessible interfaces between elements of a lithium-ion **battery system** shall not employ connectors of the following types:

- standard mains inlet connectors, except for mains supply connections;
- barrel connectors with outside diameters of 6,5 mm or less;
- phone plugs with a diameter of 3,5 mm or less.

Compliance is checked by inspection.

L.22 Internal wiring

This clause only applies when the tool is in the configuration where it is directly connected to the mains or to a **non-isolated source**.

L.23 Components

L.23.1.10 This subclause applies only to **power switches** of tools capable of performing their intended operation when connected to the mains or to a **non-isolated source**.

L.23.1.10.201 Power switches, other than those of tools described in L.23.1.10, shall have adequate breaking capacity.

*Compliance is checked by subjecting a switch to 50 operation cycles of making and breaking the locked output mechanism current of the **fully charged** battery-operated tool, each “on” period having a duration of not more than 0,5 s and each “off” period having a duration of at least 10 s.*

*After this test the **power switch** shall have no electrical or mechanical failure. If the switch operates properly in the “on” and “off” positions at the end of the test, it is considered to have no mechanical or electrical failure.*

L.23.1.10.202 Power switches, other than those of tools described in L.23.1.10, shall withstand, without excessive wear or other harmful effect, the mechanical, electrical, and thermal stresses occurring in the tool.

*Compliance is checked by subjecting a switch to 6 000 cycles of operation making and breaking the current encountered in the **fully charged** battery tool operated at no-load. The switch is operated at a uniform rate of 30 operations per minute. During the test the switch*

*shall operate correctly. After this test, the **power switch** shall have no electrical or mechanical failure. If the switch operates properly in the “on” and “off” positions at the end of the test, it is considered to have no mechanical or electrical failure.*

L.23.201 Cells employed in tools or cells employed in **battery** packs shall comply with IEC 62133.

NOTE The above requirement for testing according to IEC 62133 does not include the **battery** pack itself.

L.23.202 Rechargeable **cells** employed in tools or in **battery** packs shall not be of lithium-metal type.

Compliance is checked by inspection.

NOTE Lithium-ion **cells** are not lithium metal **cells**.

L.24 Supply connection and external flexible cords

L.24.1 This subclause also applies to a flexible cord between a **non-isolated source** and the tool.

L.24.3 This subclause also applies to a flexible cord between a **non-isolated source** and the tool.

L.24.4 This subclause applies, except a flexible cord provided between a **non-isolated source** and the tool shall not be provided with a plug that can be connected directly to the mains.

L.24.5 This subclause does not apply to a flexible cord provided between a **non-isolated source** and the tool.

L.24.20 This subclause applies, except a flexible cord provided between a **non-isolated source** and the tool shall not be provided with an appliance inlet that can be connected directly to the mains.

L.24.201 For battery tools with **separable battery packs**, the external flexible cable or cord shall have anchorages such that the conductors are relieved from strain, including twisting, where they are connected within the tool, and protected from abrasion.

Compliance is checked by inspection.

L.25 Terminals for external conductors

This clause does not apply to **interconnection cords**.

L.26 Provision for earthing

This clause only applies when the tool is in the configuration where it is directly connected to the mains or to a **non-isolated source**.

L.28 Creepage distances, clearances and distances through insulation

This clause is applicable except as follows:

L.28.1 Addition:

This subclause only applies when the tool is in the configuration where it is directly connected to the mains or to a **non-isolated source**. During the evaluation in this condition, **battery** packs are to be connected to the tool. The tool is also evaluated with the **battery** pack removed if such removal can be accomplished without the use of a tool.

Between parts of opposite polarity that are live during charging, the **creepage distances** and **clearances** of IEC 60335-1:2010 shall apply, if they are greater than the values in Table 12.

L.28.201 Creepage distances and clearances shall not be less than values in millimetres shown in Table L.1. The **clearances** specified do not apply to the air gap between the contacts of thermal controls, overload protection devices, switches of micro-gap construction, and the like, or to the air gap between the current-carrying members of such devices where the **clearances** vary with the movement of the contacts. **Creepage distances and clearances** also do not apply to the construction of **battery cells** or the interconnections between **cells** in a **battery** pack. The values specified in Table L.1 do not apply to cross-over points of motor windings.

The values in Table L.1 are equal or larger than the values required by IEC 60664-1, when

- an overvoltage category II;
- a material group III;
- a pollution degree 1 for parts protected against deposition of dirt and for lacquered or enamelled windings;
- a pollution degree 3 for other parts;
- inhomogeneous electric field

are applied.

For parts of different polarity, **clearance** and **creepage distances** less than those given in Table L.1 are acceptable if the shorting of the two parts does not result in the tool starting.

NOTE 1 The risk of fire due to spacings below the required values is covered by the requirements of 18.1.

Table L.1 – Minimum creepage distances and clearances between parts of opposite polarity

Dimensions in millimetres

Working voltage ≤ 15 V		Working voltage > 15 V and ≤ 32 V		Working voltage > 32 V	
Creepage distance	Clearance	Creepage distance	Clearance	Creepage distance	Clearance
0,8 ^a	0,8	1,5	1,5	2,0 ^a	1,5
^a These creepage distances are slightly lower than suggested by IEC 60664-1. Creepage distances between live parts of different polarity (functional insulation) are only associated to fire hazard, not to electric shock hazard. As products in the scope of IEC 62841 are products supervised during normal use , lower distances are justified.					

For parts having a **hazardous voltage** between them, the sum total of the measured distances between each of these parts and their nearest accessible surface shall not be less than 1,5 mm **clearance** and 2,0 mm **creepage distance**.

NOTE 2 Figure L.1 provides clarification on the measurement method.

Compliance is checked by measurement.

The way in which **creepage distances** and **clearances** are measured is indicated in Annex A.

Distances through slots or openings in external parts of insulating material are measured to metal foil in contact with the accessible surface; the foil is pushed into corners and the like by means of the test probe B of IEC 61032:1997, but is not pressed into openings.

The sum total of distances measured between parts operating at **hazardous voltage** and accessible surfaces is determined by measuring the distance from each part to the accessible surface. The distances are to be added together to determine the sum total. See Figure L.1. For the purpose of this determination, one of the distances shall be 1,0 mm or greater. See Annex A, cases 1 to 10.

If necessary, a force is applied to any point on bare conductors and to the outside of metal enclosures, in an endeavour to reduce the **creepage distances** and **clearances** while taking the measurements.

The force is applied by means of the test probe B of IEC 61032:1997 and has a value of:

- 2 N for bare conductors;
- 30 N for enclosures.

Means provided for fixing the tool to a support are considered to be accessible.

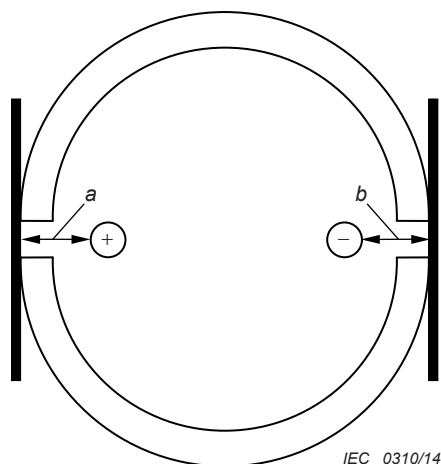

Dimension a = distance from positive bare conductive part to the external surface as defined by foil stretched across the openings.

Dimension b = distance from negative bare conductive part to the external surface as defined by foil stretched across the openings.

$a + b$ is the sum total as defined in L.28.201.

Figure L.1 – Measurement of clearances

Bibliography

IEC 60127-3, *Miniature fuses – Part 3: Sub-miniature fuse-links*

NOTE Harmonized as EN 60127-3. 

IEC 60204 (all parts), *Safety of machinery – Electrical equipment of machines*

NOTE Harmonized as EN 60204 Series. 

IEC 60335 (all parts), *Household and similar electrical appliances – Safety*

NOTE Harmonized as EN 60335 Series. 

IEC 60335-2-29, *Household and similar electrical appliances – Safety – Part 2-29: Particular requirements for battery chargers*

NOTE Harmonized as EN 60335-2-29. 

IEC 60335-2-45, *Household and similar electrical appliances – Safety – Part 2-45: Particular requirements for portable heating tools and similar appliances*

NOTE Harmonized as EN 60335-2-45. 

IEC 60601 (all parts), *Medical electrical equipment*

NOTE Harmonized as EN 60601 Series. 

IEC 60664-3, *Insulation coordination for equipment within low-voltage systems – Part 3: Use of coating, potting or moulding for protection against pollution*

NOTE Harmonized as EN 60664-3. 

IEC 62281, *Safety of primary and secondary lithium cells and batteries during transport*

NOTE Harmonized as EN 62281. 

British Standards Institution (BSI)

BSI is the national body responsible for preparing British Standards and other standards-related publications, information and services.

BSI is incorporated by Royal Charter. British Standards and other standardization products are published by BSI Standards Limited.

About us

We bring together business, industry, government, consumers, innovators and others to shape their combined experience and expertise into standards-based solutions.

The knowledge embodied in our standards has been carefully assembled in a dependable format and refined through our open consultation process. Organizations of all sizes and across all sectors choose standards to help them achieve their goals.

Information on standards

We can provide you with the knowledge that your organization needs to succeed. Find out more about British Standards by visiting our website at bsigroup.com/standards or contacting our Customer Services team or Knowledge Centre.

Buying standards

You can buy and download PDF versions of BSI publications, including British and adopted European and international standards, through our website at bsigroup.com/shop, where hard copies can also be purchased.

If you need international and foreign standards from other Standards Development Organizations, hard copies can be ordered from our Customer Services team.

Subscriptions

Our range of subscription services are designed to make using standards easier for you. For further information on our subscription products go to bsigroup.com/subscriptions.

With **British Standards Online (BSOL)** you'll have instant access to over 55,000 British and adopted European and international standards from your desktop. It's available 24/7 and is refreshed daily so you'll always be up to date.

You can keep in touch with standards developments and receive substantial discounts on the purchase price of standards, both in single copy and subscription format, by becoming a **BSI Subscribing Member**.

PLUS is an updating service exclusive to BSI Subscribing Members. You will automatically receive the latest hard copy of your standards when they're revised or replaced.

To find out more about becoming a BSI Subscribing Member and the benefits of membership, please visit bsigroup.com/shop.

With a **Multi-User Network Licence (MUNL)** you are able to host standards publications on your intranet. Licences can cover as few or as many users as you wish. With updates supplied as soon as they're available, you can be sure your documentation is current. For further information, email bsmusales@bsigroup.com.

BSI Group Headquarters

389 Chiswick High Road London W4 4AL UK

Revisions

Our British Standards and other publications are updated by amendment or revision.

We continually improve the quality of our products and services to benefit your business. If you find an inaccuracy or ambiguity within a British Standard or other BSI publication please inform the Knowledge Centre.

Copyright

All the data, software and documentation set out in all British Standards and other BSI publications are the property of and copyrighted by BSI, or some person or entity that owns copyright in the information used (such as the international standardization bodies) and has formally licensed such information to BSI for commercial publication and use. Except as permitted under the Copyright, Designs and Patents Act 1988 no extract may be reproduced, stored in a retrieval system or transmitted in any form or by any means – electronic, photocopying, recording or otherwise – without prior written permission from BSI. Details and advice can be obtained from the Copyright & Licensing Department.

Useful Contacts:

Customer Services

Tel: +44 845 086 9001

Email (orders): orders@bsigroup.com

Email (enquiries): cservices@bsigroup.com

Subscriptions

Tel: +44 845 086 9001

Email: subscriptions@bsigroup.com

Knowledge Centre

Tel: +44 20 8996 7004

Email: knowledgecentre@bsigroup.com

Copyright & Licensing

Tel: +44 20 8996 7070

Email: copyright@bsigroup.com



...making excellence a habit.™