

BS EN 62779-1:2016



BSI Standards Publication

Semiconductor devices — Semiconductor interface for human body communication

Part 1: General requirements

National foreword

This British Standard is the UK implementation of EN 62779-1:2016. It is identical to IEC 62779-1:2016.

The UK participation in its preparation was entrusted to Technical Committee EPL/47, Semiconductors.

A list of organizations represented on this committee can be obtained on request to its secretary.

This publication does not purport to include all the necessary provisions of a contract. Users are responsible for its correct application.

© The British Standards Institution 2016.

Published by BSI Standards Limited 2016

ISBN 978 0 580 77912 1

ICS 31.080.01

Compliance with a British Standard cannot confer immunity from legal obligations.

This British Standard was published under the authority of the Standards Policy and Strategy Committee on 30 June 2016.

Amendments/corrigenda issued since publication

Date	Text affected
-------------	----------------------

EUROPEAN STANDARD
NORME EUROPÉENNE
EUROPÄISCHE NORM

EN 62779-1

June 2016

ICS 31.080.01

English Version

**Semiconductor devices - Semiconductor interface for human
body communication - Part 1: General requirements
(IEC 62779-1:2016)**

Dispositifs à semiconducteurs - Interface à
semiconducteurs pour les communications via le corps
humain - Partie 1: Exigences générales
(IEC 62779-1:2016)

Halbleiterbauelemente - Halbleiterschnittstelle zur
Kommunikation über den menschlichen Körper -
Teil 1: Allgemeine Anforderungen
(IEC 62779-1:2016)

This European Standard was approved by CENELEC on 2016-03-24. CENELEC members are bound to comply with the CEN/CENELEC Internal Regulations which stipulate the conditions for giving this European Standard the status of a national standard without any alteration.

Up-to-date lists and bibliographical references concerning such national standards may be obtained on application to the CEN-CENELEC Management Centre or to any CENELEC member.

This European Standard exists in three official versions (English, French, German). A version in any other language made by translation under the responsibility of a CENELEC member into its own language and notified to the CEN-CENELEC Management Centre has the same status as the official versions.

CENELEC members are the national electrotechnical committees of Austria, Belgium, Bulgaria, Croatia, Cyprus, the Czech Republic, Denmark, Estonia, Finland, Former Yugoslav Republic of Macedonia, France, Germany, Greece, Hungary, Iceland, Ireland, Italy, Latvia, Lithuania, Luxembourg, Malta, the Netherlands, Norway, Poland, Portugal, Romania, Slovakia, Slovenia, Spain, Sweden, Switzerland, Turkey and the United Kingdom.



European Committee for Electrotechnical Standardization
Comité Européen de Normalisation Electrotechnique
Europäisches Komitee für Elektrotechnische Normung

CEN-CENELEC Management Centre: Avenue Marnix 17, B-1000 Brussels

European foreword

The text of document 47/2267/FDIS, future edition 1 of IEC 62779-1, prepared by IEC/TC 47 "Semiconductor devices" was submitted to the IEC-CENELEC parallel vote and approved by CENELEC as EN 62779-1:2016.

The following dates are fixed:

- latest date by which the document has to be implemented at national level by publication of an identical national standard or by endorsement (dop) 2016-12-24
- latest date by which the national standards conflicting with the document have to be withdrawn (dow) 2019-03-24

Attention is drawn to the possibility that some of the elements of this document may be the subject of patent rights. CENELEC [and/or CEN] shall not be held responsible for identifying any or all such patent rights.

Endorsement notice

The text of the International Standard IEC 62779-1:2016 was approved by CENELEC as a European Standard without any modification.

In the official version, for Bibliography, the following note has to be added for the standard indicated :

IEC 62779 NOTE Harmonized in EN 62779 series.

CONTENTS

FOREWORD.....	3
INTRODUCTION.....	5
1 Scope.....	6
2 Normative references.....	6
3 Terms, definitions and letter symbols	6
3.1 General terms	6
3.2 Rating and characteristics	7
3.2.1 Input characteristics	7
3.2.2 Transfer characteristics	7
3.3 Letter symbols	9
4 General requirements for HBC semiconductor interface.....	9
4.1 General specifications	9
4.1.1 General	9
4.1.2 Function	9
4.1.3 Implementation types	10
4.2 Constructional specifications	10
4.3 Electrical specifications	11
4.3.1 General	11
4.3.2 Power supply characteristics	11
4.3.3 Power supply type.....	11
4.3.4 Dynamic characteristics of analog front end.....	11
4.3.5 CDR circuit interface	11
4.3.6 Modem interface	12
4.3.7 Limiting values.....	12
4.3.8 Temperatures	12
4.4 Operating specifications	12
4.4.1 Application.....	12
4.4.2 Grounding condition	13
4.4.3 Contact condition	13
Annex A (informative) General description of HBC.....	14
Annex B (informative) Generation of powerline noise signal in HBC	15
Annex C (informative) Calculation of sensitivity level	16
Bibliography	17
Figure 1 – Definition of cut-off frequency and bandwidth.....	8
Figure 2 – Block diagram (example).....	10
Figure A.1 – HBC applications	14
Figure B.1 – Coupling of electromagnetic fields and the human body	15
Table 1 – Letter symbols.....	9

INTERNATIONAL ELECTROTECHNICAL COMMISSION

**SEMICONDUCTOR DEVICES –
SEMICONDUCTOR INTERFACE FOR HUMAN BODY COMMUNICATION –****Part 1: General requirements**

FOREWORD

- 1) The International Electrotechnical Commission (IEC) is a worldwide organization for standardization comprising all national electrotechnical committees (IEC National Committees). The object of IEC is to promote international co-operation on all questions concerning standardization in the electrical and electronic fields. To this end and in addition to other activities, IEC publishes International Standards, Technical Specifications, Technical Reports, Publicly Available Specifications (PAS) and Guides (hereafter referred to as "IEC Publication(s)"). Their preparation is entrusted to technical committees; any IEC National Committee interested in the subject dealt with may participate in this preparatory work. International, governmental and non-governmental organizations liaising with the IEC also participate in this preparation. IEC collaborates closely with the International Organization for Standardization (ISO) in accordance with conditions determined by agreement between the two organizations.
- 2) The formal decisions or agreements of IEC on technical matters express, as nearly as possible, an international consensus of opinion on the relevant subjects since each technical committee has representation from all interested IEC National Committees.
- 3) IEC Publications have the form of recommendations for international use and are accepted by IEC National Committees in that sense. While all reasonable efforts are made to ensure that the technical content of IEC Publications is accurate, IEC cannot be held responsible for the way in which they are used or for any misinterpretation by any end user.
- 4) In order to promote international uniformity, IEC National Committees undertake to apply IEC Publications transparently to the maximum extent possible in their national and regional publications. Any divergence between any IEC Publication and the corresponding national or regional publication shall be clearly indicated in the latter.
- 5) IEC itself does not provide any attestation of conformity. Independent certification bodies provide conformity assessment services and, in some areas, access to IEC marks of conformity. IEC is not responsible for any services carried out by independent certification bodies.
- 6) All users should ensure that they have the latest edition of this publication.
- 7) No liability shall attach to IEC or its directors, employees, servants or agents including individual experts and members of its technical committees and IEC National Committees for any personal injury, property damage or other damage of any nature whatsoever, whether direct or indirect, or for costs (including legal fees) and expenses arising out of the publication, use of, or reliance upon, this IEC Publication or any other IEC Publications.
- 8) Attention is drawn to the Normative references cited in this publication. Use of the referenced publications is indispensable for the correct application of this publication.
- 9) Attention is drawn to the possibility that some of the elements of this IEC Publication may be the subject of patent rights. IEC shall not be held responsible for identifying any or all such patent rights.

International Standard IEC 62779-1 has been prepared by IEC technical committee 47:Semiconductor devices.

The text of this standard is based on the following documents:

FDIS	Report on voting
47/2267/FDIS	47/2277/RVD

Full information on the voting for the approval of this standard can be found in the report on voting indicated in the above table.

This publication has been drafted in accordance with the ISO/IEC Directives, Part 2.

A list of all parts in the IEC 62779 series, published under the general title *Semiconductor devices – Semiconductor interface for human body communication*, can be found on the IEC website.

The committee has decided that the contents of this publication will remain unchanged until the stability date indicated on the IEC web site under "<http://webstore.iec.ch>" in the data related to the specific publication. At this date, the publication will be

- reconfirmed,
- withdrawn,
- replaced by a revised edition, or
- amended.

IMPORTANT – The 'colour inside' logo on the cover page of this publication indicates that it contains colours which are considered to be useful for the correct understanding of its contents. Users should therefore print this document using a colour printer.

INTRODUCTION

The IEC 62779 series is composed of three parts as follow:

- IEC 62779-1 defines general requirements of a semiconductor interface for human body communication. It includes general and functional specifications of the interface.
- IEC 62779-2 defines a measurement method on electrical performances of an electrode that constructs a semiconductor interface for human body communication.
- IEC 62779-3¹ defines functional type of a semiconductor interface for human body communication, and operational conditions of the interface.

IEC 60748-4 gives requirements on interface integrated circuits for semiconductor devices. Especially, Chapter III, Section 7 in this standard is applied to interface circuits for a communication network using a general channel, such as wire or wireless. However, a channel for HBC is the human body whose channel properties, such as signal loss and delay profile, are different from the general channel, so Chapter III, Section 7 can't be applied to an interface for HBC. Furthermore, a standard on a communication protocol for body area network (BAN) – IEEE 802.15.6, which includes a communication protocol for HBC was published in 2012. A common interface for HBC should be defined to secure communication compatibility between various devices that are implemented on/inside the human body or embedded in peripheral equipments.

¹ To be published.

SEMICONDUCTOR DEVICES – SEMICONDUCTOR INTERFACE FOR HUMAN BODY COMMUNICATION –

Part 1: General requirements

1 Scope

This part of IEC 62779 defines general requirements for a semiconductor interface used in human body communication (HBC). It includes general and functional specifications of the interface, as well as limiting values and its operating conditions.

NOTE Additional information on HBC is provided in Annex A.

2 Normative references

The following documents, in whole or in part, are normatively referenced in this document and are indispensable for its application. For dated references, only the edition cited applies. For undated references, the latest edition of the referenced document (including any amendments) applies.

None.

3 Terms, definitions and letter symbols

For the purposes of this document, the following terms and definitions apply.

3.1 General terms

3.1.1

HBC semiconductor interface

semiconductor interface to process an electrical signal that is transmitted to the human body or received from the human body while located between the human body and HBC modem; implemented on/inside the human body and embedded in peripheral equipment

Note 1 to entry: HBC semiconductor interface consists of an electrode and analog front end. The HBC modem converts data into an electrical signal and sends it to the electrode, or receives an electrical signal from the analog front end and converts it into data.

Note 2 to entry: This note applies to the French language only.

3.1.2

electrode

physical structure to transmit an electrical signal between an analog front end and the human body while attached to or located near the human body

Note 1 to entry: An electrode transfers an electrical signal to be transmitted to a non-metallic transmission channel, the human body. It also transfers an electrical signal received from the human body to the analog front end.

3.1.3

analog front end

semiconductor integrated circuit to recover original data from a receiving signal transmitted through the human body

Note 1 to entry: Analog front end includes a powerline noise reduction filter, a signal amplifier, a high-pass filter, a comparator and a clock and data recovery (CDR) circuit to recover original data transmitted through a non-

metallic transmission channel. Also, it generates control signals to control operations of each component in the analog front end.

3.1.4

powerline noise reduction filter

circuit component in an analog front end to remove a powerline noise signal included in a receiving signal by an antenna function of the human body

Note 1 to entry: Additional information on generation of a powerline noise signal is provided in Annex B.

3.1.5

comparator

circuit component in an analog front end to compare two signals and switch its output signal to indicate which is larger

3.1.6

CDR circuit

circuit component in an analog front end to generate a clock from a receiving signal and align phase of the receiving signal to the generated clock

3.2 Rating and characteristics

3.2.1 Input characteristics

3.2.1.1

supply voltage

V_S
supply voltage to operate a HBC semiconductor interface

3.2.1.2

normal mode supply current

I_S
total supply current during normal mode of a HBC semiconductor interface

3.2.1.3

disabled mode supply current

I_{DISABLED}
total supply current during disabled mode of a HBC semiconductor interface

3.2.1.4

input impedance

Z_I
impedance seen by the human body into a HBC semiconductor interface

Note 1 to entry: Input impedance depends on input impedances of a powerline noise reduction filter, signal amplifier and high-pass filter.

Note 2 to entry: A powerline noise reduction filter removes a high-power noise signal which can saturate the active components in the interface.

3.2.2 Transfer characteristics

3.2.2.1

sensitivity level

SL
signal's minimum voltage at an input of a HBC semiconductor interface that is required to produce a signal having a specified signal-to-noise ratio at an output

Note 1 to entry: Additional information on the sensitivity level is provided in Annex C.

Note 2 to entry: This note applies to the French language only.

3.2.2.2 dynamic range

DR

ratio of a signal's maximum voltage at an input of a HBC semiconductor interface that can be tolerated without signal distortion to a minimum that is required to have a specific signal-to-noise ratio at an output

Note 1 to entry: Dynamic range depends on a minimum drive level of a comparator and a signal gain of a signal amplifier. Additional information on the sensitivity level is provided in Annex C.

Note 2 to entry: This note applies to the French language only.

3.2.2.3 voltage gain

G_V

increasing amount of a signal's voltage that is gained as passing through a signal amplifier and a high-pass filter without being attenuated or removed intentionally

3.2.2.4 lower cut-off frequency

$f_{\text{CUT,LOWER}}$

lower frequency where a receiving signal is attenuated by 3 dB as passing through a high-pass filter

3.2.2.5 upper cut-off frequency

$f_{\text{CUT,UPPER}}$

upper frequency where a receiving signal is attenuated by 3 dB as passing through a high-pass filter

3.2.2.6 bandwidth

BW

frequency range width over which signals having corresponding frequencies pass through a signal amplifier and a high-pass filter without being attenuated or removed intentionally (see Figure 1)

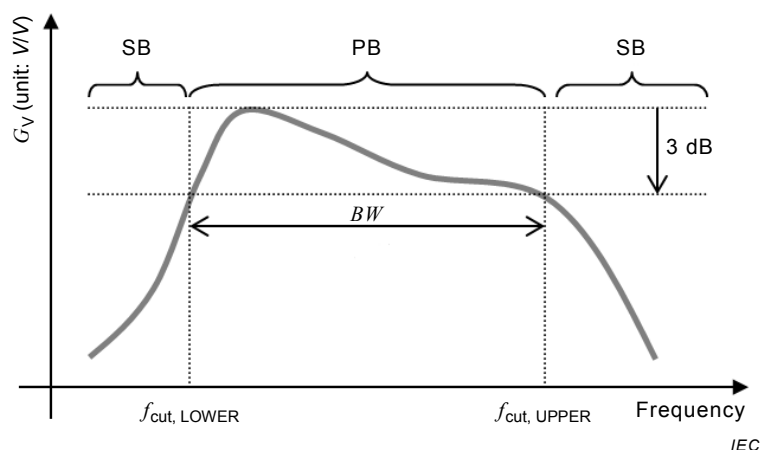

Key

G_V	Voltage Gain	SB	Stop Band
PB	Pass Band	BW	Bandwidth
$f_{\text{cut, LOWER}}$	Upper Cut-off Frequency	$f_{\text{cut, UPPER}}$	Lower Cut-off Frequency

Figure 1 – Definition of cut-off frequency and bandwidth

Note 1 to entry: This note applies to the French language only.

3.2.2.7**lock range*****LR***

frequency range's width over which the CDR circuit can be locked

Note 1 to entry: This note applies to the French language only.

3.3 Letter symbols

All the letter symbols related to input and transfer characteristics are summarized in Table 1 below.

Table 1 – Letter symbols

Name and designation	Letter symbol
supply voltage	V_S
normal mode supply current	I_S
disabled mode supply current	I_{DISABLED}
input impedance	Z_1
sensitivity level	SL
dynamic range	DR
voltage gain	G_V
lower cut-off frequency	$f_{\text{CUT,LOWER}}$
upper cut-off frequency	$f_{\text{CUT,UPPER}}$
bandwidth	BW
lock range	LR

4 General requirements for HBC semiconductor interface**4.1 General specifications****4.1.1 General**

General specifications to specify functional and external requirements for HBC semiconductor interface shall be given.

4.1.2 Function**4.1.2.1 Category**

If an interface has a functional or electrical category, it shall be stated.

4.1.2.2 Functional description

A general description of the function performed by the interface shall be given.

4.1.2.3 Block diagram

The overall structure of the interface to realize the function shall be given. Details of the structure shall be given using a block diagram (see example in Figure 2).

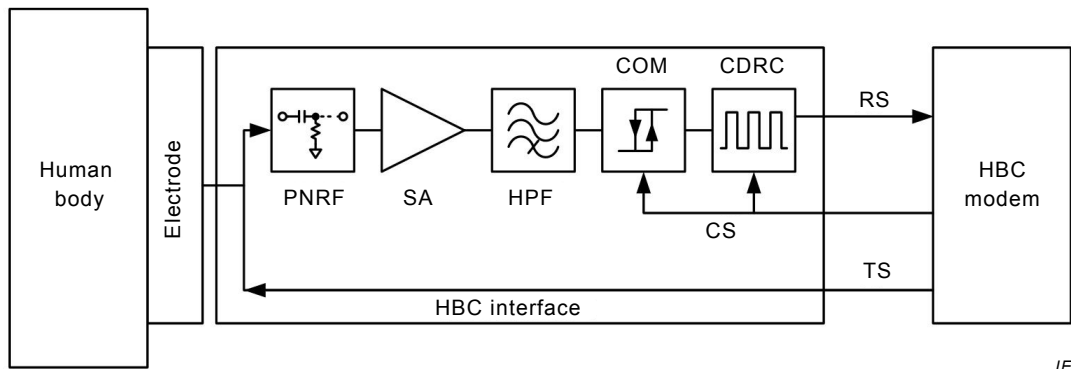
**Key**

PNRF	Powerline Noise Reduction Filter	SA	Signal Amplifier
HPF	High Pass Filter	COM	Comparator
CDRC	Clock and Data Recovery Circuit	CS	Control Signal
RS	Receiving Signal	TS	Transmitting Signal

NOTE 1 The powerline noise reduction filter can be removed if the noise signal does not have enough high power to saturate the active components in the interface.

NOTE 2 The order of the components in the interface can be changed if necessary, as long as the interface satisfies the required performances.

Figure 2 – Block diagram (example)

If applicable, control signals that are transmitted between the interface and a HBC modem shall be defined in the block diagram.

4.1.3 Implementation types

4.1.3.1 Manufacturing and assembling technology

The manufacturing technologies for an electrode, for example metallic pattern, thin film, etc., and an analog front end, for example semiconductor monolithic integrated circuit, thin-film integrated circuit, hybrid integrated circuit, module, etc, shall be stated. Details of the semiconductor technologies shall be included.

An assembling technology between an electrode and an analog front end, for example modularization, integration, shall be stated.

4.1.3.2 Package technology

The package type, for example ceramic, plastic or glass, shall be given.

If applicable, the IEC and/or national reference number of the outline drawing shall be stated.

4.2 Constructional specifications

The physical specifications of an electrode, for example material, dimensions, location, shall be given.

4.3 Electrical specifications

4.3.1 General

The electrical specifications should be given over the specified range of an operating temperature.

4.3.2 Power supply characteristics

The following characteristics shall be given.

- a) supply voltage;
- b) normal mode supply current;
- c) disabled mode supply current.

4.3.3 Power supply type

A type of power supply, for example an outlet or battery, shall be given.

4.3.4 Dynamic characteristics of analog front end

4.3.4.1 Powerline noise reduction filter, signal amplifier and high-pass filter

The following characteristics shall be given with respect to the corresponding component in a powerline noise reduction filter, signal amplifier and high-pass filter.

- a) input impedance at a powerline noise reduction filter;
- b) sensitivity level;
- c) dynamic range;
- d) maximum voltage gain over a pass band;
- e) minimum voltage gain over a pass band;
- f) decrease rate of voltage gain over a stop band;
- g) bandwidth;
- h) cut-off frequency.

NOTE The powerline noise reduction filter removes a high-power noise signal which can saturate the active components in the interface. The noise signal has the highest power usually at a powerline frequency, but if it has the highest power at a different frequency, the noise reduction filter is replaced with the one able to remove the corresponding noise signal.

4.3.4.2 Comparator and CDR circuit

The following characteristics shall be given with respect to the corresponding component in a comparator and CDR circuit.

- a) minimum input voltage;
- b) hysteresis voltage;
- c) switching threshold voltage;
- d) lock range.

4.3.5 CDR circuit interface

The specifications for the input signal of a CDR circuit, for example a line code type and logic level, shall be given.

4.3.6 Modem interface

4.3.6.1 Data

The specifications for a data signal that are exchanged between a HBC modem and an interface shall be given.

4.3.6.2 Clock

The specifications for a clock signal used for synchronization shall be given.

4.3.6.3 Enabling signal

The specifications for an enabling signal to enable a HBC interface shall be given.

4.3.7 Limiting values

4.3.7.1 Details to be stated

- Any dependency between the limiting values shall be specified.
- If externally connected and/or attached elements have an influence on the limiting values, the elements and their conditions shall be specified.
- If the limiting values are exceeded for transient overload, the permissible excesses and their durations shall be specified.
- All voltages are referenced to a specific reference terminal.
- The limiting values given shall cover an interface's operation over the specified range of operating temperature. If the limiting values are dependent on temperature, the dependency shall be given.

4.3.7.2 Electrical limiting values

Limiting values of the following items shall be given:

- a) supply voltage;
- b) supply current – normal mode;
- c) supply power;
- d) input voltage at an electrode.

4.3.8 Temperatures

The following temperatures shall be given:

- a) operating temperature;
- b) storage temperature.

4.4 Operating specifications

4.4.1 Application

4.4.1.1 Main application

The main application shall be stated, for example file transfer, real-time audio streaming and video download.

If there is any restriction in applications, it shall be stated.

4.4.1.2 Compatibility

A communication standard, for example IEEE 802.15.6 standard, that is compatible to this interface standard shall be stated. Details of the standard including its communication protocol shall be given.

4.4.2 Grounding condition

A grounding condition of an interface, for example earth or floating grounding, shall be given.

4.4.3 Contact condition

A contact condition for an electrode, for example contact or non-contact (proximity), shall be given.

Annex A (informative)

General description of HBC

In human body communication (HBC), the body of a user is used to transmit data from one device to another, and devices can thereby communicate without a wire or wireless technology. An electrical signal including data is transmitted through the body, so the user simply touches the devices, and then the devices are connected to each other via touch-and-play (TAP) technology as shown in Figure A.1.

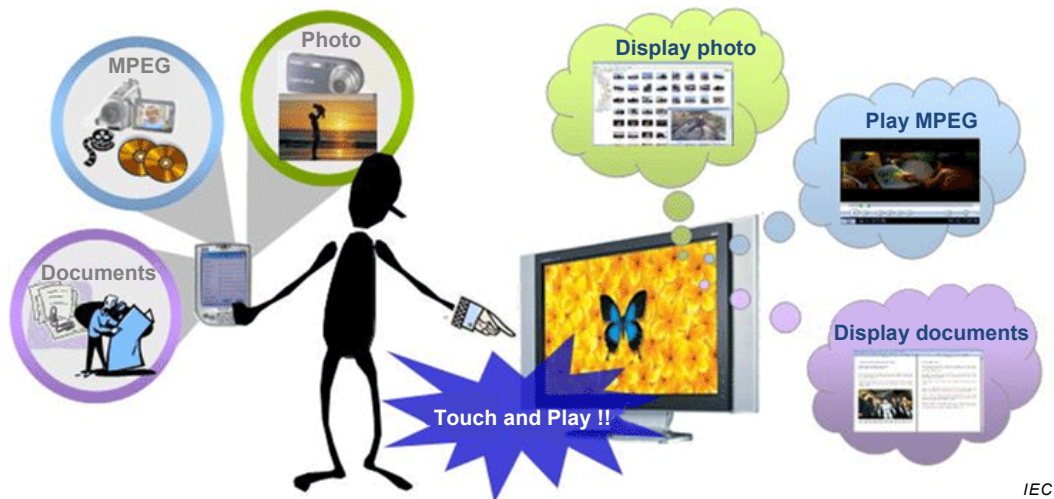

Figure A.1 – HBC applications

HBC technology is very suitable for providing a context awareness service based on TAP. After devices are connected by touch, identification signals are transmitted through the user's body, so that the type of the devices is recognized by each other. A service to be provided for the pair of the devices is determined according to the predefined context table, and then the determined service is provided while data is transmitted through the user's body. Various services which can be provided for other pairs of the devices are defined in the context table, so that a corresponding service between recognized devices can be automatically provided without the user's intervention. For example, when a user touches an advertisement device with one hand while holding a PDA in the other hand, the touch is detected by the advertisement device and the device sends information about the advertisement through the user's body, so the information can be downloaded into the PDA. Data communication between multiple devices, such as body sensor network, is also possible using HBC technology while those devices are being in contact with body. One of the devices defined as the master device controls data transmission between other devices defined as slave devices, so the user's body can be shared by the multiple devices for the data communication.

A HBC interface is defined as the connection part that inputs a data signal to the human body or outputs from the human body, while being located between a device and the human body. An electrical signal including data passes through the HBC interface from the user's device to the human body, or vice versa. The HBC interface is composed of two parts: an electrode and an analog front end. The electrode is a small piece of metal or other substance that is used to transmit the electrical signal to the human body or to receive it from the human body, while being in contact with the human body. The electrical signal transmitted to the human body is attenuated and distorted as passing through the human body. The analog front end is the circuit that restores the transmitted electrical signal from the attenuated and distorted signal. The structure of the HBC interface varies according to the HBC application. In addition, it can be implemented in a separable type with the user's device or an embedded type inside the device.

Annex B (informative)

Generation of powerline noise signal in HBC

Electrical systems surrounding the human body radiate noise signals in the form of electromagnetic fields (EMFs), and the electromagnetic fields are coupled with the human body as shown in Figure B.1, so the noise signals are induced in the received electrical signal by HBC. It has been generally accepted that a noise signal from a powerline has the largest signal power among the noise signals, so a powerline noise reduction filter is required to maintain a permissible signal-to-noise ratio in a HBC semiconductor interface.

A powerline noise signal usually has a very high signal level, so the powerline noise reduction filter is comprised of passive components, such as lumped resistors or capacitors, to avoid saturated operation of the filter. Also, the noise reduction filter is located between the electrode and the signal amplifier to prevent saturated operation of other circuit components.

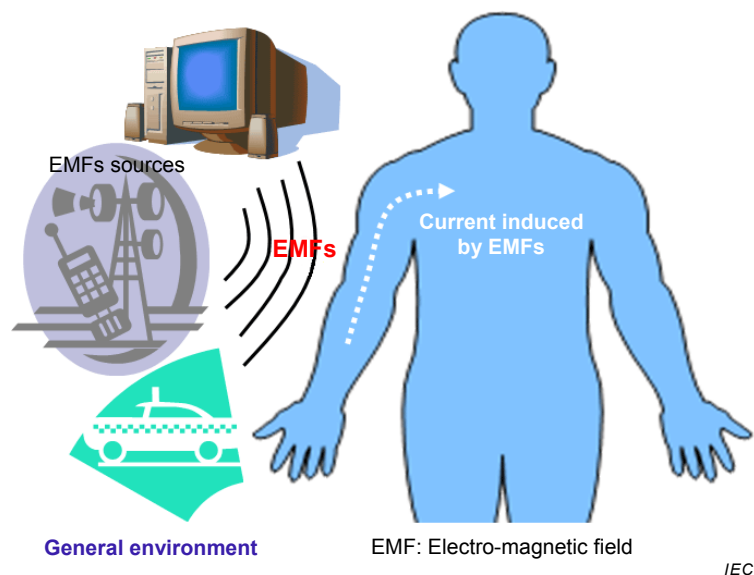

Figure B.1 – Coupling of electromagnetic fields and the human body

Annex C (informative)

Calculation of sensitivity level

The sensitivity level depends on the minimum drive level of a comparator and the signal gain of a signal amplifier as follows.

$$V_{\text{sensitivity}} = V_{\text{min. drive level}} - G \quad (\text{C.1})$$

Here, $V_{\text{sensitivity}}$ is the sensitivity level of a HBC semiconductor interface in dB and $V_{\text{min. drive level}}$ is the minimum input drive level of the comparator in dB. Also, G is the signal gain of the signal amplifier in dB.

The sensitivity level should be designed to satisfy Formula (C.2).

$$V_{\text{sensitivity}} > L_{\text{body, max}} + V_{\text{transmitting}} \quad (\text{C.2})$$

Here, $L_{\text{body, max}}$ is the maximum signal loss of the human body in dB and $V_{\text{transmitting}}$ is the signal level of transmitting data in dB.

From the required sensitivity level of Formula (C.1), the signal gain of the signal amplifier and the minimum input drive level of the comparator should be designed to satisfy Formula (C.1).

Bibliography

IEC 60748-4:1997, *Semiconductor devices – Integrated circuits – Part 4: Interface integrated circuits*

IEC 62779 (all parts), *Semiconductor devices – Semiconductor interface for human body communication*

IEEE 802.15.6:2012, *Standard for Local and Metropolitan area networks – Part 15.6: Wireless Body Area Networks*

British Standards Institution (BSI)

BSI is the national body responsible for preparing British Standards and other standards-related publications, information and services.

BSI is incorporated by Royal Charter. British Standards and other standardization products are published by BSI Standards Limited.

About us

We bring together business, industry, government, consumers, innovators and others to shape their combined experience and expertise into standards-based solutions.

The knowledge embodied in our standards has been carefully assembled in a dependable format and refined through our open consultation process. Organizations of all sizes and across all sectors choose standards to help them achieve their goals.

Information on standards

We can provide you with the knowledge that your organization needs to succeed. Find out more about British Standards by visiting our website at bsigroup.com/standards or contacting our Customer Services team or Knowledge Centre.

Buying standards

You can buy and download PDF versions of BSI publications, including British and adopted European and international standards, through our website at bsigroup.com/shop, where hard copies can also be purchased.

If you need international and foreign standards from other Standards Development Organizations, hard copies can be ordered from our Customer Services team.

Copyright in BSI publications

All the content in BSI publications, including British Standards, is the property of and copyrighted by BSI or some person or entity that owns copyright in the information used (such as the international standardization bodies) and has formally licensed such information to BSI for commercial publication and use.

Save for the provisions below, you may not transfer, share or disseminate any portion of the standard to any other person. You may not adapt, distribute, commercially exploit, or publicly display the standard or any portion thereof in any manner whatsoever without BSI's prior written consent.

Storing and using standards

Standards purchased in soft copy format:

- A British Standard purchased in soft copy format is licensed to a sole named user for personal or internal company use only.
- The standard may be stored on more than 1 device provided that it is accessible by the sole named user only and that only 1 copy is accessed at any one time.
- A single paper copy may be printed for personal or internal company use only.

Standards purchased in hard copy format:

- A British Standard purchased in hard copy format is for personal or internal company use only.
- It may not be further reproduced – in any format – to create an additional copy. This includes scanning of the document.

If you need more than 1 copy of the document, or if you wish to share the document on an internal network, you can save money by choosing a subscription product (see 'Subscriptions').

Reproducing extracts

For permission to reproduce content from BSI publications contact the BSI Copyright & Licensing team.

Subscriptions

Our range of subscription services are designed to make using standards easier for you. For further information on our subscription products go to bsigroup.com/subscriptions.

With **British Standards Online (BSOL)** you'll have instant access to over 55,000 British and adopted European and international standards from your desktop. It's available 24/7 and is refreshed daily so you'll always be up to date.

You can keep in touch with standards developments and receive substantial discounts on the purchase price of standards, both in single copy and subscription format, by becoming a **BSI Subscribing Member**.

PLUS is an updating service exclusive to BSI Subscribing Members. You will automatically receive the latest hard copy of your standards when they're revised or replaced.

To find out more about becoming a BSI Subscribing Member and the benefits of membership, please visit bsigroup.com/shop.

With a **Multi-User Network Licence (MUNL)** you are able to host standards publications on your intranet. Licences can cover as few or as many users as you wish. With updates supplied as soon as they're available, you can be sure your documentation is current. For further information, email subscriptions@bsigroup.com.

Revisions

Our British Standards and other publications are updated by amendment or revision.

We continually improve the quality of our products and services to benefit your business. If you find an inaccuracy or ambiguity within a British Standard or other BSI publication please inform the Knowledge Centre.

Useful Contacts

Customer Services

Tel: +44 345 086 9001

Email (orders): orders@bsigroup.com

Email (enquiries): cservices@bsigroup.com

Subscriptions

Tel: +44 345 086 9001

Email: subscriptions@bsigroup.com

Knowledge Centre

Tel: +44 20 8996 7004

Email: knowledgecentre@bsigroup.com

Copyright & Licensing

Tel: +44 20 8996 7070

Email: copyright@bsigroup.com

BSI Group Headquarters

389 Chiswick High Road London W4 4AL UK