

BS EN 62680-4:2014



BSI Standards Publication

**Universal serial bus interfaces
for data and power -
Part 4: Universal Serial Bus
Cables and Connectors Class
Document, Revision 2.0**

bsi.

...making excellence a habit.™

National foreword

This British Standard is the UK implementation of EN 62680-4:2014. It is identical to IEC 62680-4:2013.

The UK participation in its preparation was entrusted to Technical Committee EPL/100, Audio, video and multimedia systems and equipment.

A list of organizations represented on this committee can be obtained on request to its secretary.

This publication does not purport to include all the necessary provisions of a contract. Users are responsible for its correct application.

© The British Standards Institution 2014

Published by BSI Standards Limited 2014

ISBN 978 0 580 79856 6

ICS 33.120; 35.200

Compliance with a British Standard cannot confer immunity from legal obligations.

This British Standard was published under the authority of the Standards Policy and Strategy Committee on 30 April 2014.

Amendments and Corrigenda issued since publication

Date	Text affected
-------------	----------------------

EUROPEAN STANDARD
NORME EUROPÉENNE
EUROPÄISCHE NORM

EN 62680-4

April 2014

ICS 33.120; 35.200

English version

**Universal serial bus interfaces for data and power -
Part 4: Universal Serial Bus Cables and Connectors
Class Document, Revision 2.0
(IEC 62680-4:2013)**

Interfaces de bus universel en série pour
les données et l'alimentation électrique -
Partie 4: Document des classes des
câbles et des connecteurs de bus
universel en série, Révision 2.0
(CEI 62680-4:2013)

Schnittstellen des Universellen Seriellen
Busses für Daten und Energie -
Teil 4: Klasse für Kabel und
Steckverbinder des Universellen Seriellen
Busses, Überarbeitung 2.0
(IEC 62680-4:2013)

This European Standard was approved by CENELEC on 2013-07-24. CENELEC members are bound to comply with the CEN/CENELEC Internal Regulations which stipulate the conditions for giving this European Standard the status of a national standard without any alteration.

Up-to-date lists and bibliographical references concerning such national standards may be obtained on application to the CEN-CENELEC Management Centre or to any CENELEC member.

This European Standard exists in three official versions (English, French, German). A version in any other language made by translation under the responsibility of a CENELEC member into its own language and notified to the CEN-CENELEC Management Centre has the same status as the official versions.

CENELEC members are the national electrotechnical committees of Austria, Belgium, Bulgaria, Croatia, Cyprus, the Czech Republic, Denmark, Estonia, Finland, Former Yugoslav Republic of Macedonia, France, Germany, Greece, Hungary, Iceland, Ireland, Italy, Latvia, Lithuania, Luxembourg, Malta, the Netherlands, Norway, Poland, Portugal, Romania, Slovakia, Slovenia, Spain, Sweden, Switzerland, Turkey and the United Kingdom.

CENELEC

European Committee for Electrotechnical Standardization
Comité Européen de Normalisation Electrotechnique
Europäisches Komitee für Elektrotechnische Normung

CEN-CENELEC Management Centre: Avenue Marnix 17, B - 1000 Brussels

Foreword

The text of document 100/1984/CDV, future edition 1 of IEC 62680-4, prepared by Technical Area 14 "Interfaces and methods of measurement for personal computing equipment" of IEC/TC 100 "Audio, video and multimedia systems and equipment" was submitted to the IEC-CENELEC parallel vote and approved by CENELEC as EN 62680-4:2014.

The following dates are fixed:

- latest date by which the document has to be implemented at national level by publication of an identical national standard or by endorsement (dop) 2014-10-11
- latest date by which the national standards conflicting with the document have to be withdrawn (dow) 2016-07-24

Attention is drawn to the possibility that some of the elements of this document may be the subject of patent rights. CENELEC [and/or CEN] shall not be held responsible for identifying any or all such patent rights.

Endorsement notice

The text of the International Standard IEC 62680-4:2013 was approved by CENELEC as a European Standard without any modification.

INTRODUCTION

The IEC 62680 series is based on a series of specifications that were originally developed by the USB Implementers Forum (USB-IF). These specifications were submitted to the IEC under the auspices of a special agreement between the IEC and the USB IF.

The USB Implementers Forum, Inc.(USB-IF) is a non-profit corporation founded by the group of companies that developed the Universal Serial Bus specification. The USB-IF was formed to provide a support organization and forum for the advancement and adoption of Universal Serial Bus technology. The Forum facilitates the development of high-quality compatible USB peripherals (devices), and promotes the benefits of USB and the quality of products that have passed compliance testing.

ANY USB SPECIFICATIONS ARE PROVIDED TO YOU "AS IS, "WITH NO WARRANTIES WHATSOEVER, INCLUDING ANY WARRANTY OF MERCHANTABILITY, NON-INFRINGEMENT, OR FITNESS FOR ANY PARTICULAR PURPOSE. THE USB IMPLEMENTERS FORUM AND THE AUTHORS OF ANY USB SPECIFICATIONS DISCLAIM ALL LIABILITY, INCLUDING LIABILITY FOR INFRINGEMENT OF ANY PROPRIETARY RIGHTS, RELATING TO USE OR IMPLEMENTATION OR INFORMATION IN THIS SPECIFICATION.

THE PROVISION OF ANY USB SPECIFICATIONS TO YOU DOES NOT PROVIDE YOU WITH ANY LICENSE, EXPRESS OR IMPLIED, BY ESTOPPEL OR OTHERWISE, TO ANY INTELLECTUAL PROPERTY RIGHTS.

Entering into USB Adopters Agreements may, however, allow a signing company to participate in a reciprocal, royalty-free licensing arrangement for compliant products. For more information, please see:

<http://www.usb.org/developers/docs/>

http://www.usb.org/developers/devclass_docs#approved

IEC DOES NOT TAKE ANY POSITION AS TO WHETHER IT IS ADVISABLE FOR YOU TO ENTER INTO ANY USB ADOPTERS AGREEMENTS OR TO PARTICIPATE IN THE USB IMPLEMENTERS FORUM.”

This series covers the Universal Serial Bus interfaces for data and power and consists of the following parts:

IEC 62680-1, *Universal Serial Bus interfaces for data and power – Part 1: Universal Serial Bus Specification, Revision 2.0*

IEC 62680-2, *Universal Serial Bus interfaces for data and power – Part 2: USB Micro-USB Cables and Connectors Specification, Revision 1.01*

IEC 62680-3, *Universal Serial Bus interfaces for data and power – Part 3: USB Battery Charging Specification, Revision 1.2*

IEC 62680-4, *Universal Serial Bus interfaces for data and power – Part 4: Universal Serial Bus Cables and Connectors Class Document Revision. 2.0*

This part of the IEC 62680 series consists of several distinct parts:

- the main body of the text, which consists of the original specification developed by the USB-IF.

CONTENTS

1	Introduction	10
1.1	Purpose	10
1.2	Scope.....	10
1.3	Related Documents	10
1.4	Terms and Abbreviations.....	11
2	Management Overview	12
3	USB Electrical, Mechanical and Environmental Compliance Standards.....	12
4	Acceptance Criteria, Test Methods and Test Procedures	15
4.1	Integrators List (IL).....	15
4.2	USB Logo Usage.....	16
4.3	Compliance Test Report	16
4.4	Connector and Cable Assembly Physical Certification	16
4.5	General Information.....	16
4.5.1	Mated Pairs	16
4.5.2	Before Testing.....	16
4.5.3	Test Sequences.....	16
4.6	Sample Selection	17
4.7	USB Compliance Testing Interval	17
4.8	Primary Qualification Approval Testing	17
4.9	Sustaining Qualification Approval Testing.....	17
4.10	Compliance Test Sequences	17
4.10.1	Inspection EIA 364-18	17
4.10.2	Test Group '1'.....	19
4.10.3	Test Group '2'.....	20
4.10.4	Test Group '3'.....	21
4.10.5	Test Group '4'.....	21
4.10.6	Test Group '5'.....	23
4.10.7	Test Group '6'.....	23
4.10.8	Test Group '7'.....	24
4.10.9	Test Group '8'.....	24
5	Certification Acceptance and Submission	25
5.1	Compliance Test Report	25
5.2	Listing, Authorization and Notification.....	25
5.2.1	Listing	25
5.2.2	Authorization to use Certified USB Logo	25
5.2.3	Notification	26
	Appendices.....	27
	A Testing by Similarity – General Guidelines	27
	B Critical Dimensions	30

Universal Serial Bus Cables and Connectors Specification

**Revision 2.0
August, 2007**

Revision History

Revision	Date	Filename	Comment
2.0 RC6	August 10, 2007	CabConnRC6_Aug10.doc	Added Go/No-go & latch measurement for Micro series Added Drain wire inspection process Added pin contact visual inspection Added clarifying text to 4-axis test description
2.0 RC5	June 5, 2007	CabConn20RC5_June5	Removed Shielding Effectiveness Replace Rotational Continuity with 4-Axis continuity Other miscellaneous minor changes
2.0 RC4	May, 2007	CabConn20RC4_May07	Cable Construction inspection added
2.0	April 4, 2007	CabConn20	Removed Shielding Effectiveness, Added power line resistance test Added cable rotation test
2.0	February 14, 2007	CabConn Rev 2.0	Edits from Tsuyoshi YAMANE of Matsushita
2.0	February 13, 2007	CabConn Rev 2.0	Edited by Jim Koser new chart from Hirose
2.0	February 7, 2007	CabConn Rev 2.0	Edited draft
2.02RC2	February 6, 2007	CabConnRC2_02-06-07	Work group editorials
2.01RC2	December 6, 2006	CabConnRC2_12-06-06	Work group editorials
2.0RC2	July 11, 2006	CabConnRC2_7-11-06	Added durability requirements for Ruggedized Standard "A" receptacle and durability requirements for Micro series
2.0RC2	June 7, 2006	CabConnRC2_6-7-06	Added new critical dimensions drawings for standard "A" and "B" plugs and receptacles and changed the criteria for "mini" products to the use of go – no go gages in Appendix B
2.0RC2	March 24, 2006	CabConnRC2_3-23-06.doc	Added new IP agreement
2.0RC2	December 03, 2003	CabConnRC2.doc	Final edit during USB DWG meeting in Austin prior to posting the document to Web site
2.0RC1	October 29, 2002	CabConnRC1.doc	Adjust formatting in technical edit pass
2.0RC	August 13, 2002		Rewrite of test program to reflect current practice and general updates to reflect changes in the USB Specification.
1.1	September 1, 1999		Editorial Update for improved use. Add Appendices 'A' and 'B.'
1.0	May 22, 1999		Accepted unanimously by USB-IF DWG after 30-day posting without negative comment.
1.0RC	March 27, 1999		Release for industry comment

Revision	Date	Filename	Comment
0.9a	January 19, 1999		Moved to Revision 0.9 by consensus of the Cable & Connector Work Group. Pending final editorial cleanup RRs to be voted on at a special Cable & Connector Work Group meeting February 21, 1999.
0.9RC	December 18, 1998		Moves Document to 0.9RC by consensus of the Cable & Connector Group to Version 0.9 without Appendices Drawings and Lab Listings. Special dispensation by the DWG to move to Revision 1.0 for use at the January 1999 Plug Fest.
0.8	October 20, 1998		Release for industry comment

INTELLECTUAL PROPERTY DISCLAIMER

THIS SPECIFICATION IS PROVIDED TO YOU "AS IS" WITH NO WARRANTIES WHATSOEVER, INCLUDING ANY WARRANTY OF MERCHANTABILITY, NON-INFRINGEMENT, OR FITNESS FOR ANY PARTICULAR PURPOSE. THE AUTHORS OF THIS SPECIFICATION DISCLAIM ALL LIABILITY, INCLUDING LIABILITY FOR INFRINGEMENT OF ANY PROPRIETARY RIGHTS, RELATING TO USE OR IMPLEMENTATION OF INFORMATION IN THIS SPECIFICATION. THE PROVISION OF THIS SPECIFICATION TO YOU DOES NOT PROVIDE YOU WITH ANY LICENSE, EXPRESS OR IMPLIED, BY ESTOPPEL OR OTHERWISE, TO ANY INTELLECTUAL PROPERTY RIGHTS.

All product names are trademarks, registered trademarks, or service marks of their respective owners.

USB Cables and Connectors Class Document
© Copyright 2007 USB Implementers Forum
All rights reserved.

Contributors

Name	Company	E-mail Address
James R. Koser	Foxconn Electronics – CCWG Chair	jim.koser@foxconn.com
Tsuneki Watanabe	Foxconn Electronics	t.watanabe@foxconn.com
Jim Zhao	Foxconn Electronics	Jim.zhao@foxconn.com
George G. Olear II	Contech Research – Co-Editor	ggo@contechresearch.com
Jaremy Flake	ATL Technology – CCWG Scribe	jaremyf@atlconnect.com
Glen Chandler	Acon	glenc@acon.com
George Yee	Acon	George.Yee@acon.com
Roy Ting	ELKA International Ltd.	roy@elka.com.tw
Sophia Liu	ETC (Electronic Test Center, Taiwan)	scl@etc.org.tw
Bill Northey	FCI	William.northey@fciconnect.com
Jack Lu	Foxlink International, Inc.	Jack_lu@foxlink.com
Wen Yang	Foxlink International, Inc.	wen@foxlink.com
Yasuhiro Ishii	Fujikura Ltd	Yishii@fujikura.co.jp
Shigreu Ashida	Fujikura Ltd	Ashidas@fujikura.co.jp
Marksuk Piyavit	Fujikura Ltd	MPiyavit @fujikura.com
Hikomichi Kato	Fujikura Ltd	pakl@fujikura.com
Sathid Inthon	Fujikura Ltd	isathid @fujikura.com
Makoto Kikuchi	Fujikura Ltd	mkikuchi@fujikura.co.jp
Hiroshi Nakazawa	Hirose Electric Co. Ltd Hiroshi	Nakazawa@hirose.co.jp
Yousuke Takeuchi	Hirose Electric Co. Ltd	Yousuke_Takeuchi@hirose.co.jp
Shinya Tono	Hirose Electric Co. Ltd	Shinya_tohno@hirose.co.jp
Karl Kwiat	Hirose Electric Co. Ltd	kkwiat@hirose.com
Kazunori Ichikawa	Hirose Electric Co. Ltd	Kazunori_Ichikawa@hirose.co.jp
Toshi Sasaki	Honda Connectors	t.sasaki@honda-connectors.co.jp
Jim Eilers	Hosiden	eilersjm@hoaco.com
Tsuyoshi Kitagawa	Hosiden	kitagawat@hoaco.com
David Suryoutomo	Japan Aviation Electronics, Inc	suryoutomod@jae.com
Ron Muir	Japan Aviation Electronics, Inc	muirr@jae.com
Kazuhiro Saito	Japan Aviation Electronics, Inc	saitouk@jae.co.jp
Takahiro Deguchi	JST Mfg. Co. Ltd	tdeguchi@jst-mfg.com
Yasuhira Miya	JST Mfg. Co. Ltd	ymiya@jst-mfg.com
Yoichi Nakazawa	JST Mfg. Co. Ltd	ynakazawa@jst-mfg.com
Hironori Handa	JST Mfg. Co. Ltd	hhanda@jst-mfg.com
Vincent Chen	Longwell	vince@longwell.com
Ron Ward	Matsushita Electronics	rward@us.pewg.panasonic.com
Hitoshi Kawamura	Mitsumi	h_kawamura@sales.mitsumi.co.jp
Atsushi Nishio	Mitsumi	a_nishio@eeb.mitsumi.co.jp
Yasuhiko Shinohara	Mitsumi	y_shinohara@eeb.mitsumi.co.jp

Name	Company	E-mail Address
Scott Sommers	Molex	Scott.sommers@molex.com
E. Mark Rodda	Motorola PCS	markrodda@motorola.com
Sheldon Singleton	National Technical Systems	sheldons@ntscorp.com
Sam Liu	Newnex	saml@newnex.com
Jan Fahllund	Nokia Corporation	Jan.h.fahllund@nokia.com
Kai Silvennoine	Nokia Corporation	Kai.silvennoine@nokia.com
Richard Petrie	Nokia Corporation	Richard.petrie@nokia.com
Jussi Takaneva	Nokia Corporation	Jussi.Takaneva@nokia.com
Panu Ylihaavisto	Nokia Corporation	Panu.Ylihaavisto@nokia.com
Arthur Zarnowitz	Palm	arthur.zarnowitz@palm.com
Dave Peters	Palm	dave.peters@palm.com
Tetsuji Kawaguchi	Panasonic (Matsushita)	t Kawaguchi@us.pewg.panasonic.com
Satoshi Yamamoto	Panasonic (Matsushita)	koteyamd@sei.mew.co.jp
Tsuyoshi Yamane	Panasonic (Matsushita)	Yamane.tsuyoshi@mail.mew.co.jp
Naoyuki Ono	SMK	Naoyuki@smk.co.jp
Eric Yagi	SMK	s-yagi@smkusa.com
Scott Shuey	Tyco Electronics.	scott.shuey@tycoelectronics.com
Masaru Ueno	Tyco Electronics	Ueno.masaru@ tycoelectronics.com
Mark Paxson	USB-IF.	mpaxson@vtm-inc.com
Ed Beeman	2010 Tech for USB-IF	ed.beeman@2010tech.com

1 Introduction

1.1 Purpose

This document describes the mechanical, electrical, environmental, design and performance criteria and voluntary supplier compliance requirements for USB connectors, cable and fabricated cable assemblies. In addition, this document provides detailed requirements for the design, approval and implementation of application specific USB connectors and fabricated cable assemblies.

1.2 Scope

The information provided in this document serves as a guideline for design, development and voluntary compliance testing of USB connectors and fabricated cables assemblies, as well as defining mechanical, electrical, environmental and performance characteristics. As such, it defines how USB connectors, cable and fabricated cables assemblies are to be implemented and how manufacturers and/or fabricators will interact with the voluntary compliance requirements.

1.3 Related Documents

American Society for Testing and Materials

ASTM-D-4565 *Standard Test Methods for Physical and Environmental Performance Properties of Insulations and Jackets for Telecommunications Wire and Cable.* This specification is available through the World Wide Web site <http://www.astm.org/>

ASTM-D-4566 *Standard Test Methods for Electrical Performance Properties of Insulations and Jackets for Telecommunications Wire and Cable.* This specification is available through the World Wide Web site <http://www.astm.org/>

ANSI/EIA 364-C *Electrical Connector/Socket Test Procedures Including Environmental Classifications*, approved 1994. Available in hard copy – reference search site <http://www.nssn.org/information.html>

Underwriters Laboratories

UL STD-94 *Test procedures used to classify polymeric materials 94HB, 94V-1, 94V-2, 94-5VA, 94-5VB, 94VTM-0, 94VTM-1, 94VTM-2, 94HBF, 94HF-1, and 94HF-2.* This specification is available through the World Wide Web site <http://www.comm-2000.com/>

UL Subject-444 *Type CMP (plenum cable), Type CMR (riser cable), Type CM (commercial cable), and Type CMX (cable for restricted use.* This specification is available through the World Wide Web site <http://www.comm-2000.com/>

[USB2.0] *Universal Serial Bus Specification*, revision 2.0 (also referred to as the *USB Specification*). This specification is available on the World Wide Web site <http://www.usb.org>.

USB On-The-Go *On-The-Go Supplement to the USB 2.0 Specification* (also referred to as the *USB On-The-Go Specification*). This specification is available on the World Wide Web site <http://www.usb.org>.

1.4 Terms and Abbreviations

Term	Description
A2LA	The American Association for Laboratory Accreditation (A2LA) is a non-profit, professional membership society. A2LA coordinates and manages a broad-spectrum, nationwide laboratory accreditation system and offers training and continuing education in laboratory practices and management. A2LA offers accreditation to private, independent (for hirer), in-house and government testing laboratories in the following fields: acoustics and vibration; biological; chemical; construction materials; electrical; environmental; geotechnical; mechanical; calibration; and, nondestructive and thermal.
ANSI	American National Standards Institute
Approved Integrators List (AIL)	A listing available to USB-IF member companies at http://www.usb.org listing cable and connector products that have successfully completed a Voluntary Compliance Testing program conducted in accordance with the most current version of the USB Specification's Electrical, Mechanical and Environmental Performance Standards as shown in Chapter 6, Chapter 7 and this document.
ASTM	American Society for Testing and Materials.
ASUPS	The acronym for Application Specific USB Product Specification. An ASUPS describes the unique characteristics of a special purpose nonstandard USB connector or cable assembly specification.
C of C	Certificate of Compliance.
Characteristic	A physical, chemical, visual or any other measurable property of a product or material.
Contact Point	One electrical contact of a multi-contact connector.
CTR	Conformance Test Report
Defect	Any nonconformance of the unit of product with specified requirements.
Defective Unit	A unit of product that contains one or more defects.
DWG	USB-IF Device Working Group
EIA	Electronic Industries Association.
EMI/RFI	Electro-magnetic Interference/Radio Frequency Interference.
Full-speed	The USB 'Full-speed' data signaling rate is 12Mb/s.
High-speed	The USB 'High-speed' data signaling rate is 480Mb/s.
Low-speed	The USB 'Low-speed' data signaling rate is 1.5Mb/s.
NIST	National Institute of Standards and Technology.
Power Pair	The non-twisted pair of electrical conductors in a USB cable used to carry power from the 'host controller' and/or a 'selfpowered hub' to the device. Where the 'Red' conductor is Vbus and the 'Black' conductor is Ground.
Signal Pair	The twisted pair of electrical conductors in a USB cable used to carry data from the 'host controller' and/or a 'self-powered hub' to the device. Where the 'Green' conductor is Dplus (D+) and the 'White' conductor is Dminus (D-).
TID	Test Identification Number
Universal Serial Bus	Universal Serial Bus is a serial interconnect bus that supports transfer rates up to 480M/bps for a maximum of 127 USB devices. (Please see USB 2.0)
USB Devices	USB devices can be: 'Hubs' that provide attachment points for USB; or, 'Functions' that provide capabilities to the system, such as an ISDN connection, a digital joystick, a printer, speakers, et cetera.
CNLA	Chinese National Laboratory Accreditation

Term	Description
USB Host	The USB interface to the host computer system is referred to as the Host Controller. The Host Controller may be implemented in a combination of hardware, firmware or software. A 'root hub' is integrated within the host system to provide one or more attachment points. Additional information concerning the 'USB host' may be found in Section 4.9 and Chapter 10 of the USB Specification USB 2.0.
USB Topology	The USB connects USB devices with the USB host. The USB physical interconnection is a tiered star topology. A 'hub' is at the center of each star. Each wire segment is a point-to-point connection between the 'host' and a 'hub' or 'function,' or a 'hub' connected to another 'hub' or 'function.'
USB	The acronym for Universal Serial Bus. (Please see Universal Serial Bus.)
USB-IF	USB Implementers Forum is a nonprofit industry organization made up of original equipment manufacturers (OEMs), component manufacturers and firmware/software developers who are actively involved in the advancement of USB technology. (Please see http://www.usb.org)

2 Management Overview

This section is an overview of the contents of this document and provides a brief summary of each of the subsequent sections. It does not establish any requirements or guidelines.

Section 3 describes USB Electrical, Mechanical and Environmental Compliance Standards.

Section 4 describes the acceptance testing criteria and test procedures for USB connectors and fabricated cable assemblies.

Section 5 Certification, Acceptance and Submission

Appendices:

3 USB Electrical, Mechanical and Environmental Compliance Standards

USB cable, connectors and fabricated cable assemblies must meet or exceed the requirements specified by the most current version of Chapter 6 of the USB Specification and applicable Supplements (please see Table 3-1, USB Electrical, Mechanical and Environmental Compliance Standards).

Table 3-1 USB Electrical, Mechanical and Environmental Compliance Standards

Test Description	Test Procedure	Performance Requirement
Durability	EIA 364-09 The object of this test procedure is to detail a uniform test method for determining the effects caused by subjecting a USB connector to the conditioning action of insertion and extraction, simulating the expected life of the connectors. Durability cycling with a gauge is intended only to produce mechanical stress. Durability performed with mating components is intended to produce both mechanical and wear stress.	1500 cycles 5000 cycles for Mini "B" 10,000 cycles for Micro series 10,000 cycles for ruggedized Standard "A" Cycle rate of 500 cycles per hour if done automatically and 200 if manual cycle
Mating Force	EIA 364-13 The object of this test is to detail a standard method for determining the mechanical forces that are required for inserting a USB connector.	35 Newtons maximum at a maximum rate of 12.5 mm (0.492") per minute.

Test Description	Test Procedure	Performance Requirement
Un-mating Force	EIA 364-13 The object of this test is to detail a standard method for determining the mechanical forces that are required for extracting a USB connector	10 Newtons minimum at a maximum rate of 12.5 mm (0.492") per minute. Standard A & B series 3 Newtons minimum Mini Series. 8 N minimum at a maximum rate of 12.5 mm (0.492") per minute for MicroUSB
Temperature Life	EIA 364-17 Test Condition 4 - Method A. The object of this test procedure is to detail a standard method to assess the ability of a USB connector to withstand +85° C ± 2 temperatures without applied voltage for 500 hours	Must meet the minimum requirements specified by the most current version of Chapter 6 of the USB Specification and must be free of cosmetic and/or mechanical imperfections that will prevent normal use.
Visual & Dimensional Inspection	EIA 364-18 Visual, dimensional and functional inspection in accordance with the USB quality inspection plans	Must meet the minimum requirements specified by the most current version of Chapter 6 of the USB Specification. Plating thickness of contacts
Dielectric Withstanding Voltage	EIA 364-20 The object of this test procedure is to detail a test method to prove that a USB connector can operate safely at its rated voltage and withstand momentary over potentials due to switching, surges and/or other similar phenomena.	The dielectric must withstand 500 VAC for one minute at sea level. 100 V AC for Mini/Micro Series.
Insulation Resistance	EIA 364-21 The object of this test procedure is to detail a standard method to assess the insulation resistance of USB connectors. This test procedure is used to determine the resistance offered by the insulation materials and the various seals of a connector to a DC potential tending to produce a leakage of current through or on the surface of these members.	Pre test Standard — 1,000 MΩ minimum. MicroUSB — 1,000 MΩ minimum Mini Series — 100 MΩ minimum. Post test 100 MΩ minimum final.
Low Level Contact Resistance	EIA 364-23 The object of this test is to detail a standard method to measure the electrical resistance across a pair of mated contacts such that the insulating films, if present, will not be broken or asperity melting will not occur. Measurement to use Kelvin 4-wire method. Measurements shall be taken from receptacle terminal to plug terminal.	30 mΩ maximum for Standard & MicroUSB (50 mΩ maximum for Mini Series) when measured at 20 mV maximum open circuit at 100 mA. Mated test contacts must be in a connector housing. Measurements to include Power, Ground, D+ and D- contacts of connector. 10 mΩ maximum change for post test LLCR
Mechanical Shock	EIA 364-27 Test Condition H The object of this test procedure is to detail a standard method to assess the ability of a USB connector to withstand specified severity of mechanical shock	No discontinuities of 1 μS or longer duration when mated USB connectors are subjected to 11 ms duration 30 Gs halfsine shock pulses. Three shocks in each direction applied along three mutually perpendicular planes for 18 shocks.

Test Description	Test Procedure	Performance Requirement
Random Vibration	EIA 364-28 Test Condition V Test Letter A This test procedure tests the ability of USB connectors to withstand conditions involving vibration.	No discontinuities of 1 μ S or longer duration when mated USB connectors are subjected to 5.35 GRMS. 15 minutes in each of three mutually perpendicular planes.
Contact Capacitance	EIA 364-30 The object of this test is to detail a standard method to determine the capacitance between conductive elements of a USB connector.	2 pF maximum unmated per contact
Humidity Life	EIA 364-31 Test Condition A Method III The object of this test procedure is to detail a standard test method for the evaluation of the properties of materials used in USB connectors as the effects of high humidity and heat influences them.	168 Hours minimum (seven complete cycles). The USB connectors under test shall be tested in accordance with EIA 364-31.
Cable Pull-Out	EIA 364-38 Test Condition A The object of this test procedure is to detail a standard method for determining the holding effect of a USB plug cable clamp without causing any detrimental effects upon the cable or connector components when the cable is subjected to inadvertent axial tensile loads.	After the application of a steady state axial load of 40 Newtons for one minute.
Solderability	EIA 364-52 The object of this test procedure is to detail a uniform test method for determining USB connector solderability. The test procedure contained herein utilizes the solder dip technique. It is not intended to test or evaluate solder cup, solder eyelet, other hand-soldered type or SMT type terminations.	USB contact solder tails shall pass 95% coverage after 8-hour steam age. Note: If lead free solder is required, solder temperature is 256° C .
Thermal Shock	EIA 364-32 Test Condition I The object of this test is to determine the resistance of a USB connector to exposure at extremes of high and low temperatures and to the shock of alternate exposures to these extremes, simulating the worst case conditions for storage, transportation and application.	10 Cycles –55°C and +85°C. The USB connectors under test must be mated. There shall be no evidence of damage.
Mixed Flowing Gas	EIA 364-65 Class II A The object of this 10-day (5 days unmated and 5 days mated) test procedure is to produce environmentally related corrosive atmospheres to determine the reaction to plated or unplated surfaces when exposed to different concentrations of flowing industrial gas mixtures. USB connector evaluation samples should be mated and placed in an environmentally controlled 'test chamber' that is monitored by a gas analyzing system for controlled concentrations of the specified gas mixture. Test coupons shall also be used and the weight gain reported.	30 m Ω maximum (50 m Ω maximum for Mini Series) when measured at 20 mV maximum open circuit at 100 mA. Mated test contacts must be in a connector housing. 10 m Ω maximum change for post test LLCR after 1 durability cycle.

Test Description	Test Procedure	Performance Requirement
Propagation Delay	EIA 364 -103 The purpose of the test is to verify the end-to-end propagation of the cable assembly.	26ns Maximum 200ps rise time see TP for details 10ns for Micro-USB due to a maximum cable length of 2 meters
Propagation Delay Skew	EIA 364 – 103 This test ensures that the signal on both the D+ and D- lines of cable assembly arrive at the receiver at the same time.	100ps Maximum 200ps rise time
Attenuation	EIA 364 – 101 This test ensures a cable assembly can provide adequate signal strength to the receiver in order to maintain a low error rate.	-1.90 dB Max @ 100.0 MHz -3.20 dB Max @ 200.0 MHz -5.80 dB Max @ 400.0 MHz
Impedance (Differential)	EIA 364 – 108 This test ensures that the signal conductors of a cable assembly have the proper impedance. Measured 2ns out from the launching connector.	76.5 Ω minimum 103.5 Ω maximum. 200ps rise time
Contact Plating thickness	Use of x-ray to measure each layer of contact plating	Must meet minimum requirement as defined in the USB 2.0 Specification and Micro-USB specification in the mating zone
Cable Assembly Voltage Drop	5V nominal at 500mA.	125mV max drop across power pair from pin to pin

Note 1: Impedance, Propagation Delay and Skew Test Fixture. This fixture will be used with the TDR for measuring the time domain performance of the cable under test. The fixture impedance should be matched to the equipment, typically 50Ω. Coaxial connectors should be provided on the fixture for connection from the TDR.

Note 2: Attenuation Text Fixture. This fixture provides a means of connection from the network analyzer to the Series 'A' plug. Since USB signals are differential in nature and operate over balanced cable, a transformer or balun (North Hills NH13734 or equivalent) is ideally used. The transformer converts the unbalanced (also known as single-ended) signal from the signal generator which is typically a 50Ω output, to the balanced (also known as differential) and likely different impedance loading presented by the cable. A second transformer or balun should be used on the other end of the cable under test to convert the signal back to an unbalanced form of the correct impedance to match the network analyzer.

4 Acceptance Criteria, Test Methods and Test Procedures

For a USB connector or fabricated cable assembly product to be listed on the USB-IF Integrators List, the manufacturer must show satisfactory completion of all qualification tests specified in the most current version of the USB Specification and the USB-IF Cable & Connector Class Document.

Cable assemblies must implement certified USB connectors in order to submit the cable assembly for certification testing.

IMPORTANT NOTICE: Fabricated USB connectors and cable assemblies must successfully pass all inspection procedures and compliance testing at the intervals shown in Table 4-3, Primary Qualification Approval Testing, and Table 4-4, Sustaining Qualification Approval Testing, of the most current version of the USB-IF Cable & Connector Class Document before listing on the USB-IF Integrators List will be granted.

4.1 Integrators List (IL)

USB-IF maintains a current listing of 'IL manufacturers and/or fabricators' who have been authorized to use the trademarked '*USB logo*' in conjunction with or on their connector and/or fabricated cable assembly products. The USB-IF's listing of approved manufacturers is periodically updated and is available to all USB-IF member companies.

4.2 USB Logo Usage

Only products that meet or exceed the compliance test requirements identified in this document at the time of testing are eligible to display the certified logo provided the product vendor has signed the USB IF logo trademark license agreement.

4.3 Compliance Test Report

The testing laboratory performing the compliance testing will issue a certified test report concisely detailing the tests performed. The certified test report must contain complete test results (inclusive of the raw data). Upon completion of compliance testing, the certified laboratory shall be responsible for notifying the USB IF with the products test results. Upon acceptance of the test results confirming compliance to this document the product will be added to the integrators list.

4.4 Connector and Cable Assembly Physical Certification

In case of conflict between the requirements of this document and the USB Specification, the most current revision of the USB Specification & applicable USB Supplements shall take precedence. Unless otherwise specified, all tests shall be performed at the following standard test conditions. Please check <http://compliance.usb.org> for the latest updates to the USB-IF Cable and Connector Compliance Program.

Table 4-1 Standard Test Conditions

Temperature	15o C to 35o C
Air Pressure	86 to 106 kPa
Relative Humidity	25% to 85%

Table 4-2 Performance Levels

Performance Level	EIA Certification	Temperature Degrees C	Humidity % RH	Marine Atmosphere	Harsh Environment
1	G1.1	25o C to 65o C	40% to 75%	No	No

Note: Testing details are described in paragraphs 4.7 and 4.8.

4.5 General Information

This document shows minimum compliance tests to be performed, the order in which they shall be performed and the performance requirements for each test.

4.5.1 Mated Pairs

Mated pairs will consist of one USB Receptacle and USB Plug and will be tested as such unless otherwise specified. Typically in most tests, the USB Receptacle is 'fixed' and the USB Plug is 'free.' Each 'receptacle' and 'plug' shall be clearly and individually identified.

Note: 'Mated connectors' MUST remain together for the duration of the testing sequence. For example, when 'un-mating' is required by a test, the same 'receptacle and plug pair' as before shall be mated for the subsequent tests.

4.5.2 Before Testing

Before testing commences, the specimens shall have been stored for at least 24 hours in the non-inserted state under standard test conditions, unless otherwise specified.

4.5.3 Test Sequences

In the following test sequence tables, where an EIA test is specified without a letter suffix, the latest approved revision of that test shall be used.

4.6 Sample Selection

The samples to be tested for USB Certification shall be from a production run of the product.

All acceptance tests shall be performed on the minimum number of samples specified in the appropriate table unless otherwise specified.

IMPORTANT Note: All compliance testing will be performed at the manufacturer's expense by a certified laboratory. The certified laboratory shall have direct traceability to a recognized standards organization, e.g., A2LA.

4.7 USB Compliance Testing Interval

Once a connector or cable assembly has been certified it remains certified for the life of the product. However, any change to the materials, configuration or dimensions will void certification of that product. Any modification of the manufacturing process (except for routine maintenance of equipment) will void the certification.

4.8 Primary Qualification Approval Testing

The following number of specimens shall be subjected to the tests under the conditions as specified in *Sections 4.4.1 (Environmental), 4.4.2 (Electrical) and 4.4.3 (Mechanical)*.

Table 4-3 Primary Qualification Approval Testing

Test Procedure	Number of Specimens		Performance Level 1
	Connectors	Cable Assemblies	Number of Permitted Defects
Inspection	40	25	0
1	8	8	0
2	8	n/a	0
3	8	n/a	0
4	5	n/a	0
5	5	n/a	0
6	n/a	5	0
7	3	n/a	0
8	n/a	8	0

Primary Qualification Approval Testing Notes:

- 1 Critical Dimension Inspection of some connectors may require destructive disassembly of the part for complete dimensional inspection.
- 2 The vendor is responsible for providing additional plugs (as specified by the test lab) with a cable of 200mm (or greater length) properly terminated for the test lab's setup fixtures.
- 3 Plugs designed for PCB mounting (e.g. USB flash memory drives) should be supplied with PCBs not mounted.
- 4 The vendor is responsible for providing additional receptacles (as specified by the test lab) properly mounted on a printed circuit board for the test lab's setup fixtures.
- 5 The USB-IF may require an inter-mate connector test using Certified USB connectors from other manufacturers

4.9 Sustaining Qualification Approval Testing

USB IF does not require vendors to re-qualify certified products. Please see section 4.7

4.10 Compliance Test Sequences

The following tests shall be performed in the sequence shown.

4.10.1 Inspection EIA 364-18

Visual and Dimensional Inspection and Test Group 7 Critical Dimension Inspection

Because of the inspection criteria similarities between these groups and the fact that data may be collected during inspections that can halt the subsequent test requirements, it is recommended they be conducted concurrently. Representative specimens should be subjected to the following tests to verify that a USB connector and/or cable assembly demonstrates sufficient product integrity to be processed through the remaining product acceptance test procedures 1 through 8.

4.10.1.1 Visual Inspection

The laboratory conducting the compliance testing is required to 100% visually inspect each lot of sample parts for obvious mechanical defects. Prohibited cable assemblies or connectors are not eligible for certification. Vendors should be informed of non-compliant configurations.

4.10.1.1.1 Connector

The number of contacts for the standard series USB connectors is four. Mini series and micro series USB connectors have five contacts. USB connectors with more or less contacts than those defined by the USB 2.0 Specification are not compliant and are not eligible for certification. The laboratory conducting the compliance testing is required to visually verify the number of contacts implemented in the connector.

No two contacts of a USB connector are permitted to be interconnected with the exception of the ID pin and ground of the micro A-series plug (pins 4 and 5).

4.10.1.1.2 Cable Assemblies

The cable construction for standard detachable USB cable assemblies is to be visually verified. Cable construction must contain a braided outer shield and a metallic inner shield. A drain wire of 28 AWG must be in contact with both shields. Cables must contain two data-lines of 28 AWG, and a power pair of 28 AWG to 20 AWG. Power pairs smaller than 28 AWG are prohibited. The laboratory conducting the compliance testing is required to visually verify the construction of the cable.

Cable assemblies for low-speed USB applications are not eligible for certification.

Bulk cable is not eligible for USB certification.

The cable assembly length shall be measured from the end of one connector to the end of the other connector. Cable assemblies with Standard-series plugs at both ends are limited to 5m. Cable assemblies with a Mini-B plug and Standard-A plug are limited to 4.5m. Cable assemblies with any Micro-series plugs are limited to 2m. The Standard A receptacle to Micro-A plug adapters are limited to 150mm.

4.10.1.2 Dimensional Inspection

Plating thickness measurement shall be the first measurement. Upon failure, testing will stop. See Group 7

The laboratory conducting the compliance testing will measure and record critical dimensions.

Important Note: Critical dimension and physical inspection may require the destructive physical analysis of a minimum of three samples. When performing this procedure the testing laboratory must verify Series 'A', 'B', Micro Series Connectors. USB cable assemblies submitted for compliance testing are required to use certified connectors. The Go/No-go gauge test is used in lieu of a critical dimension test for Mini-B plugs and receptacles. Micro Series plugs and receptacles will use Go/No-go gauges to confirm all interface critical dimensions and will undergo physical measurement of all latch-related critical dimensions.

4.10.2 Test Group '1'

Table 4-4 Test Group '1' Durability, Vibration, Shock, Cable Retention and Mating/Un-mating Force

Test Phase	Test			Measurement To Be Performed			Common Requirements
	Title	EIA 364 Test	Severity or Condition of Test	Title	EIA 364 Test	P1	
1-1	Mating Force	13	Measure force to mate at a rate of 12.5 mm per minute maximum			1	35 Newtons maximum Tolerance +/-0.1N
1-2	Low Level contact resistance		20 mV maximum open circuit at 100 mA maximum	Contact Resistance	23	1	Standard/Micro-USB – ≤30 mΩ Mini series – ≤50 mΩ maximum initial resistance Tolerance +/-0.1 mΩ 4-wire Kelvin All contacts measured
1-3	Durability	09	1500 cycles 5000 cycles for Mini "B" 10,000 cycles for Micro series 10,000 cycles for ruggedized Standard "A" Cycle rate of 500 cycles per hour max.			1	No physical damage and shall meet requirements of subsequent tests.
1-4	Shock	27	30g 6ms • sine 6 axes	Continuity	87	1	No contact chatter greater than 1.0 microsecond Detection via current change
1-5	Vibration	28	5.35 GRMS for 15 minutes in each of three mutually perpendicular planes	Continuity	87	1	No contact chatter greater than 1.0 microsecond Detection via current change
1-6	Low Level contact resistance		Same as 1-2	Contact Resistance	23	1	ΔR +10 mΩ maximum final. Tolerance +/-0.1 mΩ 4-wire Kelvin All contacts measured.
1-7	Un-mating Force	13	Measure force to unmate at a rate of 12.5mm per minute maximum.			1	Standard series – 10 Newtons minimum Mini series – 3 Newtons minimum. Micro series – 8 Newtons minimum Tolerance +/-0.1N
1-8	Cable Pull Out	38b	Apply steady state axial load to the cable for one minute.				40 Newtons Minimum (cable assembly shall have no electrical discontinuity and cable shall have no mechanical separation from connector.)

Test Phase	Test			Measurement To Be Performed			Common Requirements
	Title	EIA 364 Test	Severity or Condition of Test	Title	EIA 364 Test	P1	
1-9	General Examination		Unmated connectors	Visual & Dimensional Inspection	18	1	There shall be no defects that would impair normal operations.

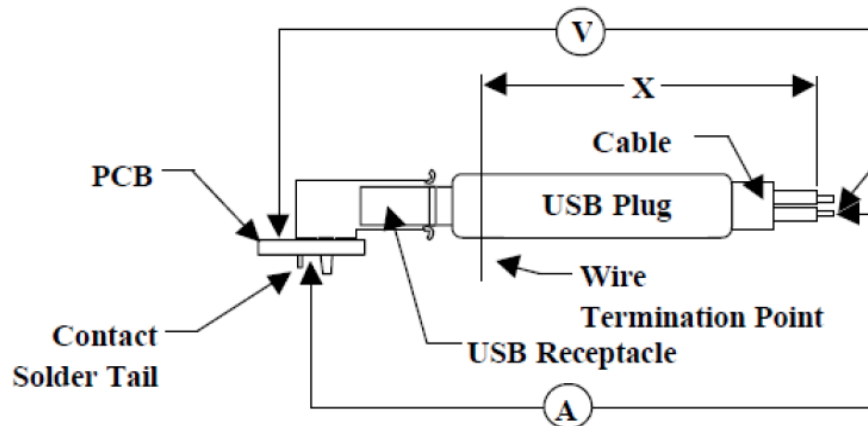

Figure 4-1 – Typical Contact Resistance Measurement

4.10.3 Test Group '2'

Table 4-5 Test Group '2' Temperature Life

Test Phase	Test			Measurement To Be Performed			Common Requirements
	Title	EIA 364 Test	Severity or Condition of Test	Title	EIA 364 Test	P1	
2-1	Low Level contact resistance		20 mV max. open circuit at 100 mA maximum, see Figure 4-1.	Contact Resistance (signal contact)	23	1	Standard/Micro – 30 mΩ Mini series – 50 mΩ maximum initial resistance.
2-2	Temperature Life	17	+85°C for 500 hours mated			1	No physical damage and shall meet requirements of subsequent tests.
2-3	Low Level contact resistance		Same as 2-1	Contact Resistance (signal contact)	23	1	ΔR +10 mΩ maximum final.
2-4	General Examination		Unmated connectors	Visual & Dimensional Inspection	18	1	There shall be no defects that would impair normal operations. Dimensions shall comply with the most current version of the USB Specification

4.10.4 Test Group '3'

Table 4-6 Test Group '3' Mixed Flowing Gas

Test Phase	Test			Measurement To Be Performed			Common Requirements
	Title	EIA 364 Test	Severity or Condition of Test	Title	EIA 364 Test	P1	
3-1	Low Level contact resistance		20 mV maximum open circuit at 100 mA maximum, see figure 4-1.	Contact Resistance (Signal Contact)	23	1	Standard/Micro – 30 mΩ Mini series – 50 mΩ maximum initial resistance.
3-2	Mixed Flowing Gas	65	Class IIA for 5 days Unmated			1	No physical damage.
3-3	Low Level contact resistance		20 mV maximum open circuit at 100 mA maximum, see figure 4-1.	Contact Resistance (Signal Contact)	23	1	After 1 mating/unmating cycle, report values. Step 3-3 Information only
3-4	Mixed Flowing Gas	65	Class IIA for 5 days Mated			1	No physical damage.
3-5	Low Level contact resistance		20 mV maximum open circuit at 100 mA maximum, see figure 4-1.	Contact Resistance (Signal Contact)	23	1	ΔR +10 mΩ maximum final
3-6	General Examination		Unmated connectors	Visual & Dimensional Inspection	18	1	There shall be no defects that would impair normal operations. Dimensions shall comply with the most current version of the USB Specification

4.10.5 Test Group '4'

Table 4-7 Test Group '4' Insulation Resistance, Dielectric Withstanding Voltage, Thermal Shock & Humidity Temperature Cycling

Test Phase	Test			Measurement To Be Performed			Common Requirements
	Title	EIA 364 Test	Severity or Condition of Test	Title	EIA 364 Test	P1	
4-1	Capacitance	30	Test between adjacent contacts unmated connector at 1 KHz.			1	2 pF maximum
4-2			500 VDC for two minutes maximum, or until stabilized, mated.	Insulation Resistance	21	1	Standard/Micro – 1000 MΩ Mini series – 100 MΩ minimum.

Test Phase	Test			Measurement To Be Performed			Common Requirements
	Title	EIA 364 Test	Severity or Condition of Test	Title	EIA 364 Test	P1	
4-3			500 VAC (100 VAC for Mini/Micro series) at sea level for one minute mated.	Withstanding Voltage	20	1	No breakdown or flashover.
4-4	Thermal Shock	32	-55°C to +85°C, 15 minutes at each temperature, and 10 cycles, mated.			1	No physical damage and shall meet requirements of subsequent tests.
4-5	Humidity-Temperature Cycling	31	25°C and 65°C at 95% RH, seven cycles, mated.			1	No physical damage and shall meet requirements of subsequent tests.
4-6			500 VDC for two minutes maximum, or until stabilized, mated.	Insulation Resistance	21	1	100 MΩ final.
4-7			500 VAC (100 VAC for Mini/Micro series) at sea level for one minute mated.	Withstanding Voltage	20	1	No breakdown or flashover.
4-8	General Examination		Unmated connectors	Visual & Dimensional Inspection	18	1	There shall be no defects that would impair normal operations. Dimensions shall comply with the most current version of the USB Specification

4.10.6 Test Group '5'

Table 4-8 Test Group '5' Solderability

Test Phase	Test			Measurement To Be Performed			Common Requirements
	Title	EIA 364 Test	Severity or Condition of Test	Title	EIA 364 Test	P1	
5-1	Solderability	52	Category 3 Steam Age RMA Class 1 flux immerse in molten solder at a temperature of +245OC ± 5OC (+473OF ± 9OF) at rate of 25.4 mm ± 6.35 mm (1.00 in ± 0.25 in) per second, hold in solder for 5 +0/-0.5 seconds To include solder pins and mounting pads.			1	Solderable area shall have a minimum of 95% solder coverage. For lead free solder pot temperature shall be +255OC ± 5OC
5-2	General Examination		Unmated connectors	Visual & Dimensional Inspection	18	1	There shall be no defects that would impair normal operations. Dimensions shall comply with the most current version of the USB Specification

4.10.7 Test Group '6'

Table 4-9 Test Group '6' High Frequency Testing

Test Phase	Test			Measurement To Be Performed			Common Requirements
	Title	EIA 364 Test	Severity or Condition of Test	Title	EIA 364 Test	P1	
6-1	Cable Impedance	108					76.5 Ω minimum 103.5 Ω maximum.
6-2	Signal Pair Attenuation	101					See Addenda C
6-3	Propagation Delay	103					26ns maximum 10 ns maximum for Micro
6-4	Propagation Delay Skew	103					100ps maximum

4.10.8 Test Group '7'

Table 4-10 Test Group '7' Critical Dimensions

Test Phase	Test			Measurement To Be Performed			Common Requirements
	Title	EIA 364 Test	Severity or Condition of Test	Title	EIA 364 Test	P1	
7-1	Critical Dimensions	18					See Addenda B Resolution +- 1micrometer
7-2	Plating thickness		Per USB2.0 chapter 6 for details for standard and Mini series and the Micro-USB specification for Micro series				Performed first. Use of X-ray to determine thickness of contacts.

4.10.9 Test Group '8'

Table 4-11 Test Group '8' Cable

Test Phase	Test			Measurement To Be Performed			Common Requirements
	Title	EIA 364 Test	Severity or Condition of Test	Title	EIA 364 Test	P1	
8-1	Voltage drop	USB 2.0	5V nominal at 500mA. c				125mV max drop across power pair from pin to pin
8-2	Cable Flex	41	x-3.7 cable diameter 100 cycles 2 planes 120 degree arc				No loss of continuity during cycling
8-3	4-Axis Continuity	n/a	Applicable to cable assemblies with micro USB plugs only. Tested as mated connectors Pull of 8N perpendicular to connection at 0, 90, 180 and 270 degrees, 10 seconds duration at each axis Verify electrical continuity of all pin contacts at each axis	Test jig defined in Appendix D.	n/a		No contact chatter greater than 1.0 microsecond during 10 seconds at each axis

Test Phase	Test			Measurement To Be Performed			Common Requirements
	Title	EIA 364 Test	Severity or Condition of Test	Title	EIA 364 Test	P1	
8-4			500 VAC (100 VAC for Mini/Micro series) at sea level for one minute mated.	Withstanding Voltage	20	1	No breakdown or flashover.
8-5	Visual Inspection			Cable Construction			Existence of braided shield attached to shell of connector Existence of 28 gauge drain wire in contact with shield and attached to shell of connector Power lines 28gauge minimum Data lines 28 gauge twisted

* Note: Standard detachable cable assemblies only. Flat cables are prohibited for standard detachable cable assemblies.

5 Certification Acceptance and Submission

Manufacturers of USB cable, connectors and/or fabricated cable assemblies desiring to have a product or products listed on the USB Implementers' Forum (USB-IF) Integrators List (IL) are required to submit 'certified proof' that their USB product meets or exceeds the performance requirements specified in Chapter 6 of the most current version of the USB Specification and this document. Certified proof of compliance shall be in the form of a Compliance Test Report (CTR) completed by an A2LA /CNLA or equivalent certified testing laboratory per IEC/ISO 17025.

5.1 Compliance Test Report

Upon successful completion of the compliance testing, the certified laboratory performing the specified tests will issue formal compliance test report. This confidential report will only be available to the manufacturer, test laboratory submitting the report and USB-IF Administration.

5.2 Listing, Authorization and Notification

5.2.1 Listing

Upon successful completion of the voluntary compliance testing, the certified laboratory performing the specified tests will provide the USB IF Administration the test results. Upon approval by the USB IF Administration of the test results, the product (s) will be added to the integrators list. The manufacturer has the option whether to display their certified products via the integrators list to the USB IF membership.

5.2.2 Authorization to use Certified USB Logo

Products that are listed on the USB IF Integrators List may use the Certified USB Logo provided that the manufacturer has agreed to and signed the USB IF Logo Trademark License Agreement. Possession of a TID does not indicate that a product is certified. Only products that are listed on the integrators list are certified.

If a manufacturer wishes to use the trademarked 'USB logo' on more than one USB product, each product displaying the 'USB logo' must have successfully completed the Voluntary Compliance Testing Program, must have a TID assigned by USB-IF, and have each product listed on the integrators list.

Only upon receiving official USB-IF Notification the manufacturer may emboss the 'USB logo' on the listed product.

5.2.3 Notification

The manufacturer of record will be notified by E-mail that their product has been listed.

Appendices

This specification has been developed as a 'living document.' In order to provide system engineers and designers the most current USB cable and connector information, USB-IF Device Working Group members may from time to time choose to add additional useful information to this document, e.g., product drawings for new USB industry standards, listings of international laboratories capable of performing approval testing, et cetera.

A Testing by Similarity – General Guidelines

USB Connector Test Requirements Qualification by Similarity Schedule USB Receptacles Style A, B													
Test Parameters	Style 'A' thru hole	Style 'A' SMT	Style 'A' (2) high	Style 'A' (3) high	Style 'A' (4) high	Style 'A' Verti -TH S		Style 'A' flag	Style 'B' thru hole	Style 'B' SMT	Style 'B' Verti -TH S		
Group	1	X	X	X	X	X	X	X	X	X	X	X	X
	2	X		X	X	X	X	X	X	X		X	X
	3	X		X	X	X				X			
	4	X		X	X	X	X	X	X	X	X	X	X
	5	X	X	X	X	X				X	X		
	7	X		X	X	X				X			

Group 1	EIA Test Procedures
Visual Examination	TP 364-18
Mating & Unmating forces	TP 364-13B
Low Level Contact Resistance	TP 364-23
Durability	TP 364-09
Random Vibration	TP 364-28
Physical Shock	TP 364-27

Group 2	EIA Test Procedures
Visual Examination	TP 364-18
Low Level Contact Resistance	TP 364-23
Temperature Life	TP 364-17

Group 3	EIA Test Procedures
Visual Examination	TP 364-18
Low Level Contact Resistance	TP 364-23
Mate/unmate (1) cycle	
Mixed Flowing Gas	TP 364-65

Group 4	EIA Test Procedures
Visual Examination	TP 364-18
Capacitance	TP 364-30
Insulation Resistance	TP 364-21
Dielectric Withstanding Voltage	TP 364-20
Thermal Shock	TP 364-32

Group 5	EIA Test Procedures
Visual Examination	TP 364-18
Solderability	TP 364-52

Group 7	EIA Test Procedures
Critical Dimensions	TP 364-18
Plating thickness	

Note: Any change in design, materials or process will require a full re-qualification of the connectors.

USB Connector Test Requirements Qualification by Similarity Schedule USB Receptacles Style Mini /Micro B and Micro AB							
Test Parameters		Style 'A' SMT	Style 'A' thru hole	Style 'B' SMT	Style 'B' thru hole	Style 'B' SMT	Style 'B' thru hole
Group	1	X	X	X	X	X	X
	2			X			
	3			X			
	4			X			
	5			X			
	7	X	X	X	X	X	X

Group 1 EIA Test Procedures

Visual Examination	TP 364-18
Mating & Unmating forces	TP 364-13B
Low Level Contact Resistance	TP 364-23
Durability	TP 364-09
Random Vibration	TP 364-28
Physical Shock	TP 364-27

Group 2 EIA Test Procedures

Visual Examination	TP 364-18
Low Level Contact Resistance	TP 364-23
Temperature Life	TP 364-17

Group 3 EIA Test Procedures

Visual Examination	TP 364-18
Low Level Contact Resistance	TP 364-23
Mate/unmate (1) cycle	
Mixed Flowing Gas	TP 364-65

Group 4 EIA Test Procedures

Visual Examination	TP 364-18
Capacitance	TP 364-30
Insulation Resistance	TP 364-21
Dielectric Withstanding Voltage	TP 364-20
Thermal Shock	TP 364-32

Group 5 EIA Test Procedures

Visual Examination	TP 364-18
Solderability	TP 364-52

Group 7 EIA Test Procedures

Critical Dimensions	TP 364-18
---------------------	-----------

USB Cable Assembly Test Requirements Qualification by Similarity Schedule USB Cable Assemblies Style A to B and Style A to Mini B, Style A to Micro B							
Test Parameters		Style 'A' to 'B' SDR	Style 'A' to 'B' Crimp	Style 'A' to Mini Series SDR	Style 'A' to Mini 'B' Crimp	Style Mini 'A' to Mini Series SDR	Style Mini 'A' to Mini Series Crimp
Group	1	X	X	X	X	X	X
	6	X	X	X	X	X	X
	8	X	X	X	X	X	X

Group 1	EIA Test Procedures
Visual Examination	TP 364-18
Mating & Unmating forces	TP 364-13B
Low Level Contact Resistance	TP 364-23
Durability	TP 364-09
Random Vibration	TP 364-28
Physical Shock	TP 364-27
Low Level Contact Resistance	TP 364-23
Mating & Unmating forces	TP 364-13B
Cable Pullout	TP 364-38A
Visual Examination	TP 364-18

Group 8	EIA Test Procedures
Visual Examination	TP 364-18
Voltage Drop	
Cable Flex	TP 364-41B
Visual Examination	TP 364-18

Group 6	EIA Test Procedures
Visual Examination	TP 364-18
Impedance	TP 364-108
Attenuation	TP 364-101
Propagation Delay	TP 364-103
Propagation Delay Skew	TP 364-103
Visual Examination	TP 364-18
Capacitance	TP 364-30

Note 1: If qualification is completed on cables of maximum length, then all cables of similar design with only a shorter length are qualified by similarity.

Note 2: If ALL connectors used are on the integrators list, no additional connector qualifications are required on the cable assemblies.

B Critical Dimensions
USB 2.0 Group 7 - Standard "A" PLUG

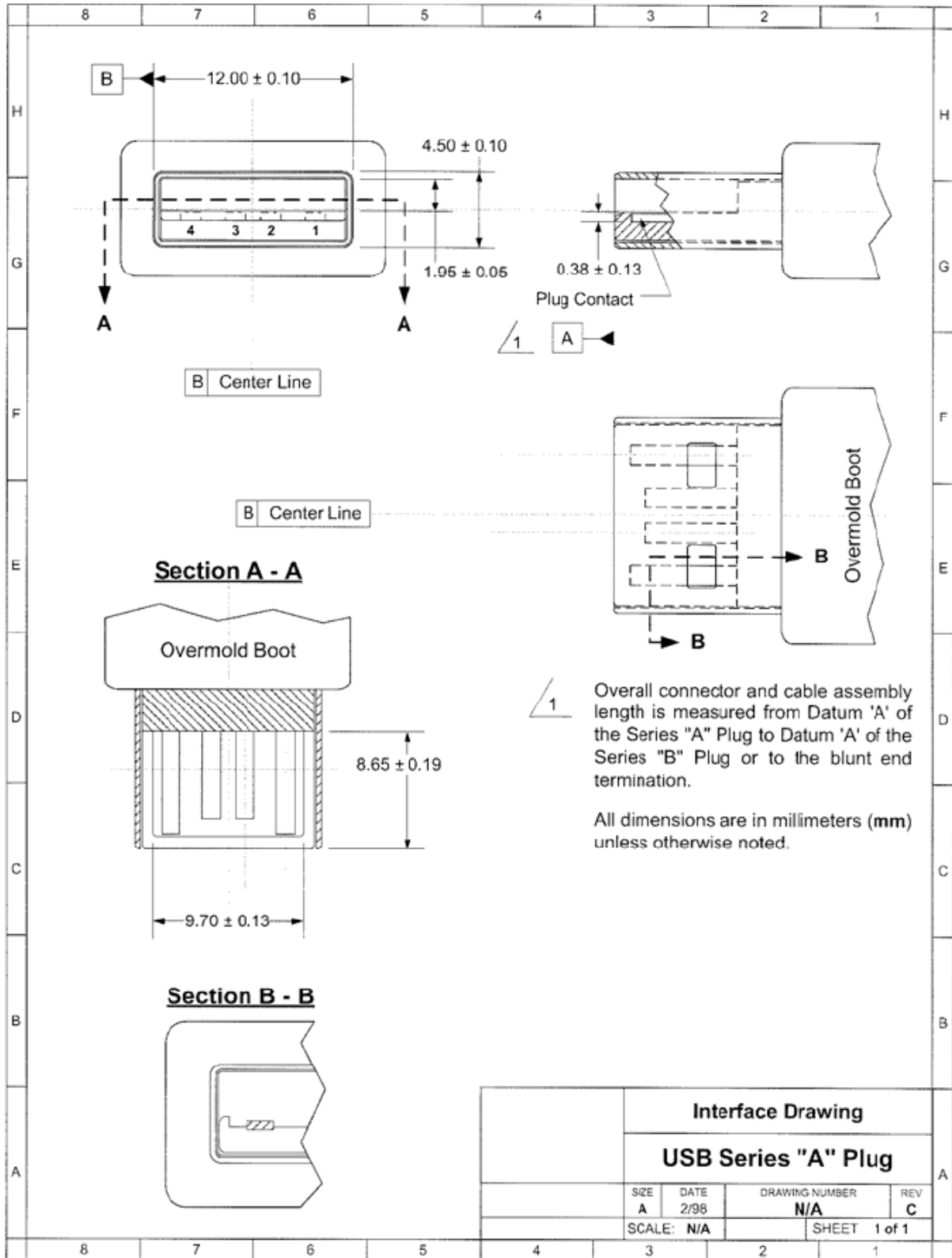

All Values are in Millimeters

USB 2.0 Group 7 - Standard "A" Receptacle

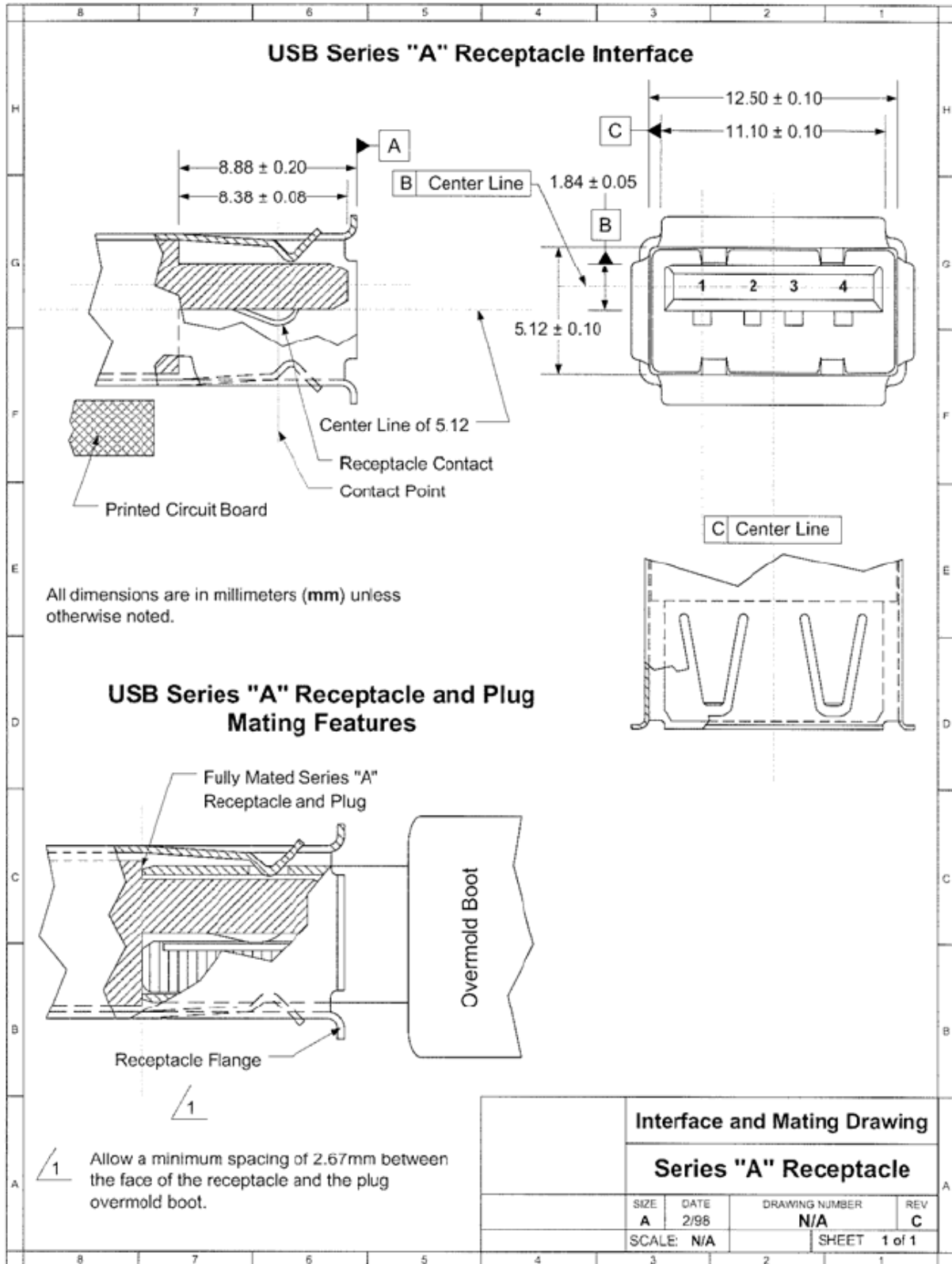

All Values are in Millimeters

USB 2.0 Group 7 - Standard "B" PLUG

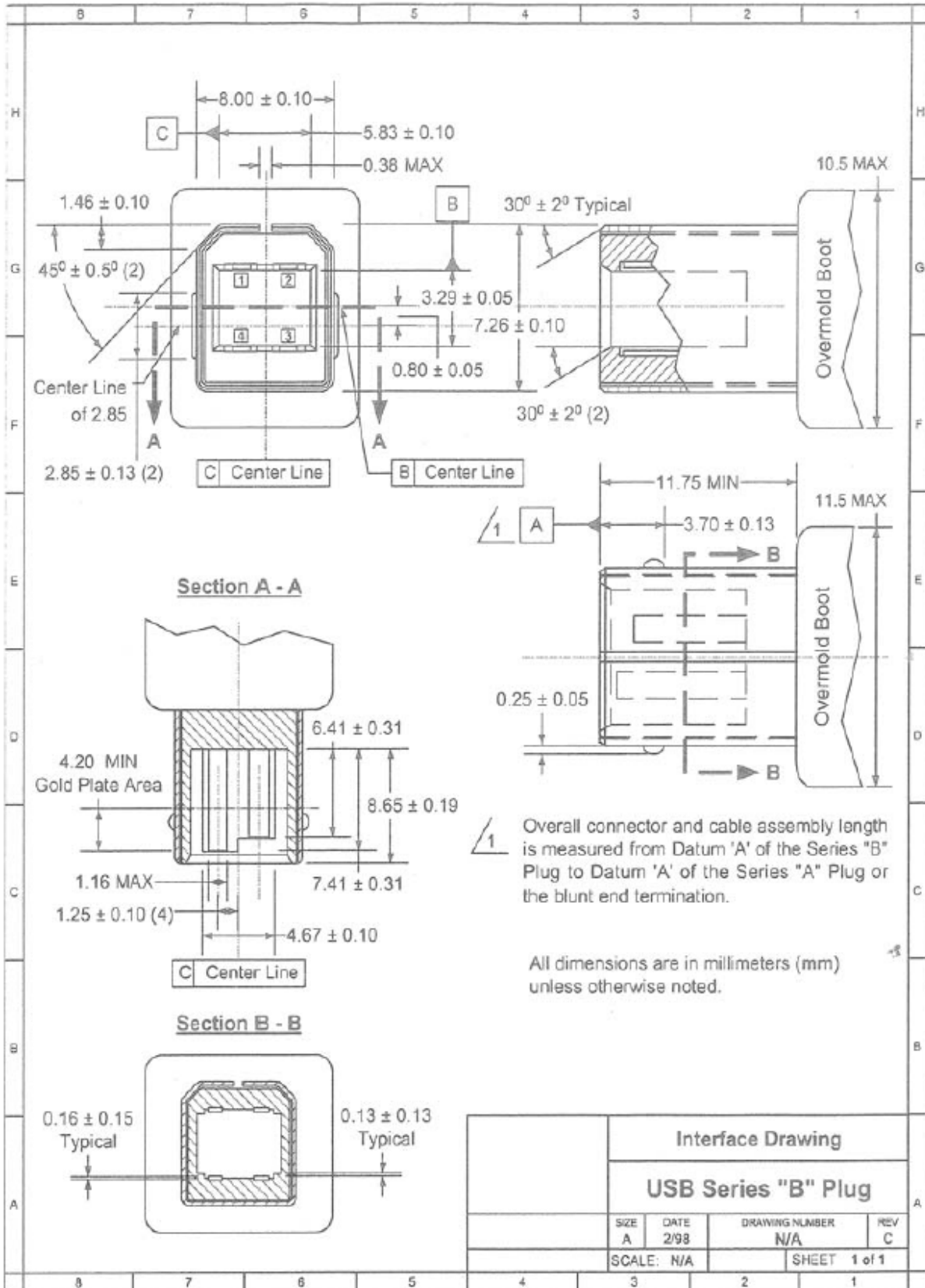

All Values are in Millimeters

USB 2.0 Group 7 - Standard "B" RECEPTACLE

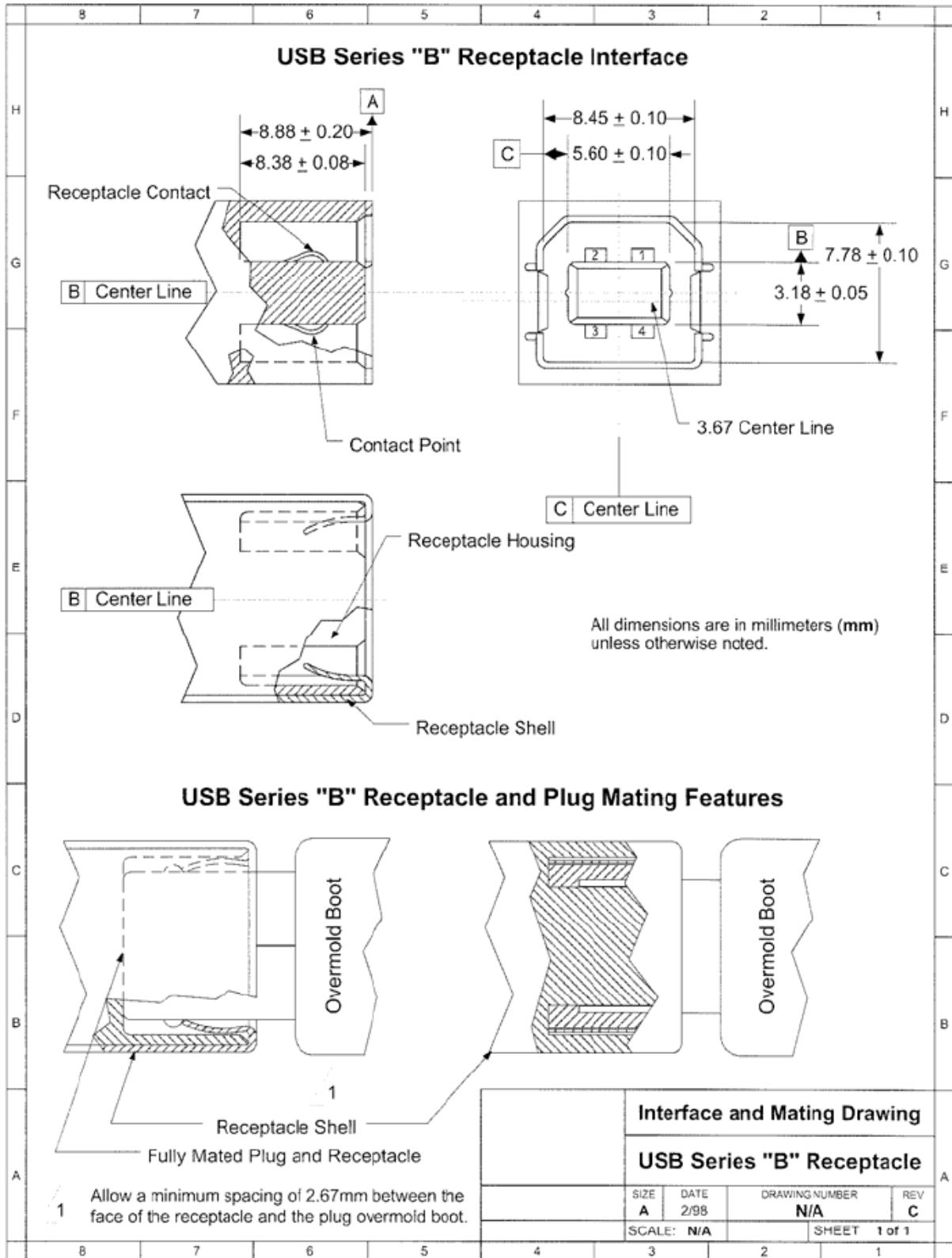

All Values are in Millimeters

USB 2.0 Group 7 - MINI "B" PLUG

USB 2.0 Group 7 - MINI "B" RECEPTACLE

USB-IF will provide Go/No-go gauges for dimensional analysis

USB 2.0 Group 7 – Micro-USB A-Plug

<u>Description</u>		<u>Dimension</u>	<u>+ tolerance</u>	<u>- tolerance</u>
Plug width	A	6.85	0.02	-0.06
Plug height	B	1.8	0.02	-0.08
Plastic width	C	3.6	n/a	0
Plastic height	D	0.85	n/a	0
Latch separation	E	4.75	0.05	-0.05
Latch width	F	0.4	0.05	-0.05
Latch height	G	0.4	n/a	0
Latch recess	J	1.05	n/a	0
Latch recess	‡	2.8	0	n/a
Pin 1 - 5 separation	H	2.6	0.05	-0.05
Pin 2 - 4 separation	I	1.3	0.05	-0.05

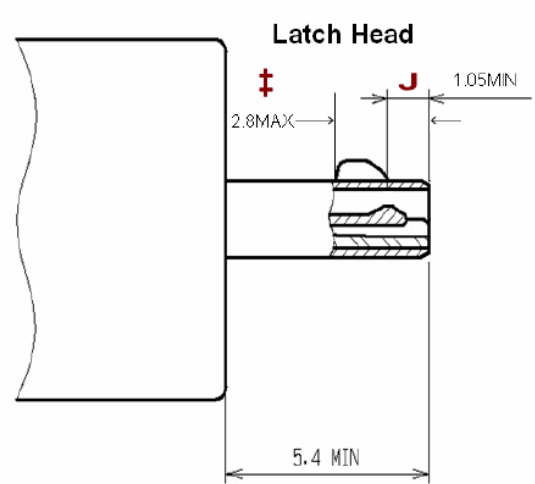
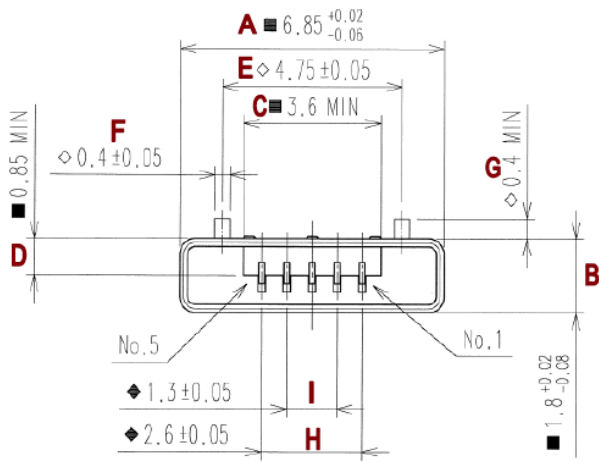

USB 2.0 Group 7 – Micro-USB B-Plug

<u>Description</u>		<u>Dimension</u>	<u>+ tolerance</u>	<u>- tolerance</u>
Plug width	A	6.85	0.02	-0.06
Plug height	B	1.8	0.02	-0.08
Plastic width	C	3.6	n/a	0
Plastic height	D	0.85	n/a	0
Shell bevel	K	5.3	0.02	-0.08
Shell bevel	L	1.03	0.02	-0.08
Latch separation	E	4.75	0.05	-0.05
Latch width	F	0.4	0.05	-0.05
Latch height	G	0.4	n/a	0
Latch recess	J	1.05	n/a	0
Latch recess	‡	2.8	0	n/a
Pin 1 - 5 separation	H	2.6	0.05	-0.05
Pin 2 - 4 separation	I	1.3	0.05	-0.05

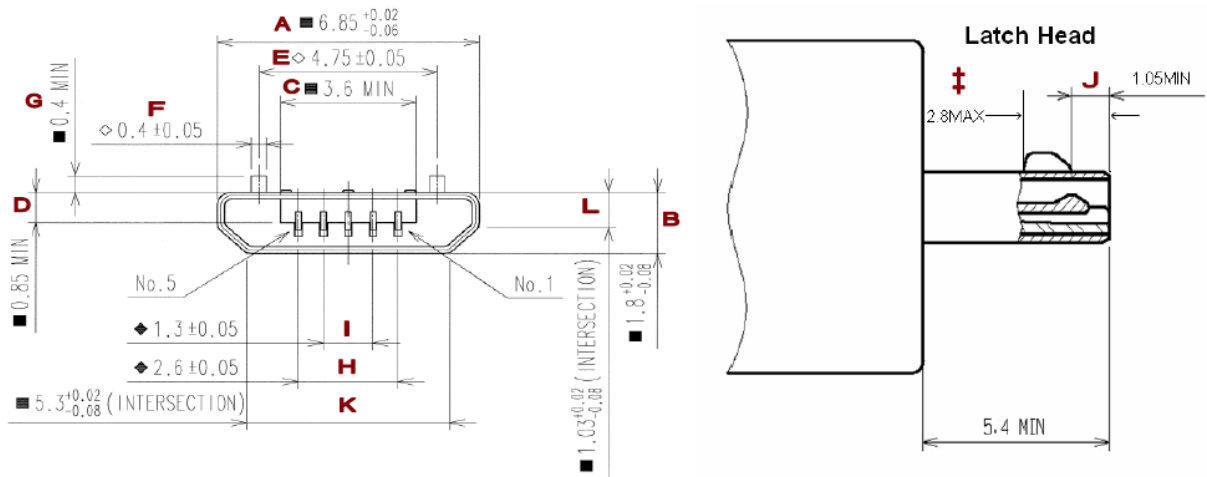

USB 2.0 Group 7 – Micro-USB B-Receptacle

<u>Description</u>		<u>Dimension</u>	<u>+ tolerance</u>	<u>- tolerance</u>
Rece inside width	M	6.9	0.06	-0.02
Rece inside height -Left	N	1.85	0.08	-0.02
Rece inside height -Right	N	1.85	0.08	-0.02
Plastic width	C	3.5	0	n/a
Plastic height	X	0.6	0.04	-0.04
Plastic from shell	U	0.22	n/a	0
Contacts from plastic	P	0.48	0.05	0
Shell inside bevel	Q	5.4	0.05	-0.05
Shell inside bevel -Left	R	1.1	0.05	-0.05
Shell inside bevel -Right	R	1.1	0.05	-0.05
Latch separation	S	4.75	0.05	-0.05
Latch width -Left	T	0.6	n/a	0
Latch width -Right	T	0.6	n/a	0
Latch recess	V	1.05	0.2	-0.2
Latch recess	W	2.55	0.1	-0.1
Latch height	Y	0.56	0	-0.15
Latch Angle	Z	60		
Pin 1 - 5 separation	H	2.6	0.05	-0.05
Pin 2 - 4 separation	I	1.3	0.05	-0.05
Contacts width	#	0.37	0.1	0

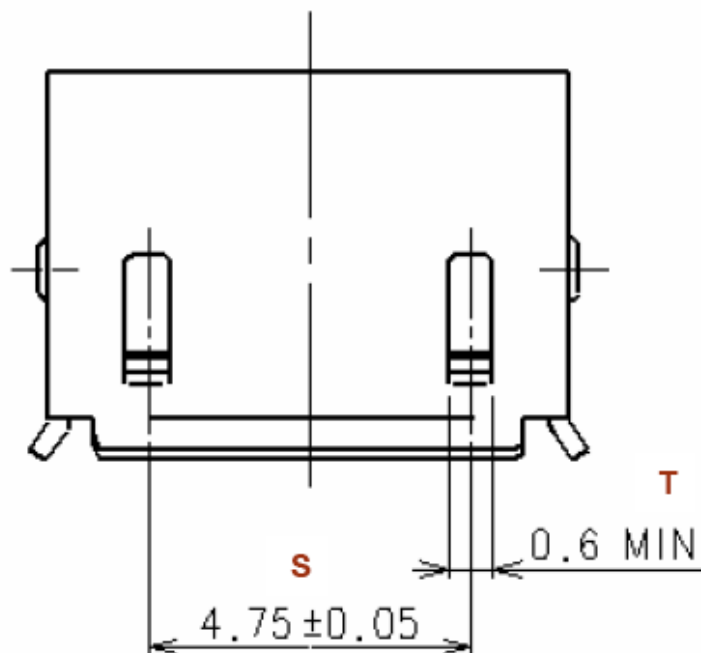

USB 2.0 Group 7 – Micro-USB B-Receptacle, Continued

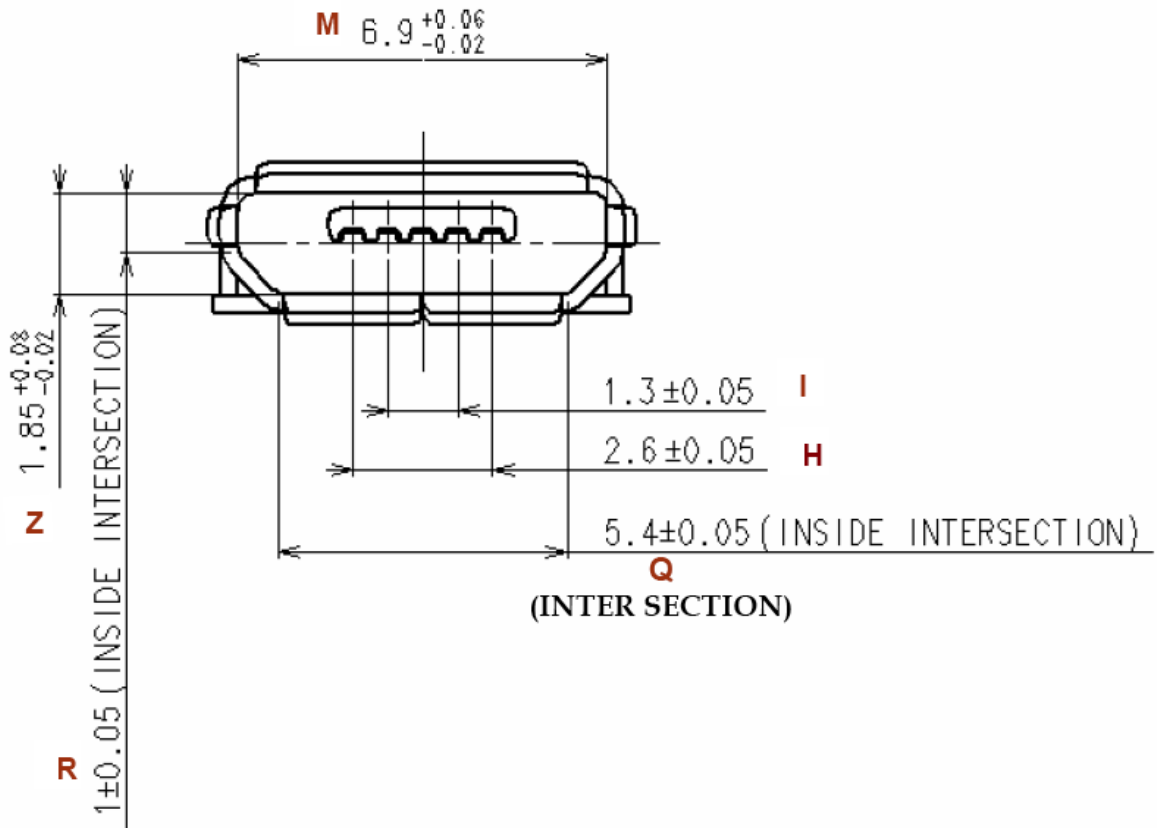

USB 2.0 Group 7 – Micro-USB B-Receptacle, Continued

A-A

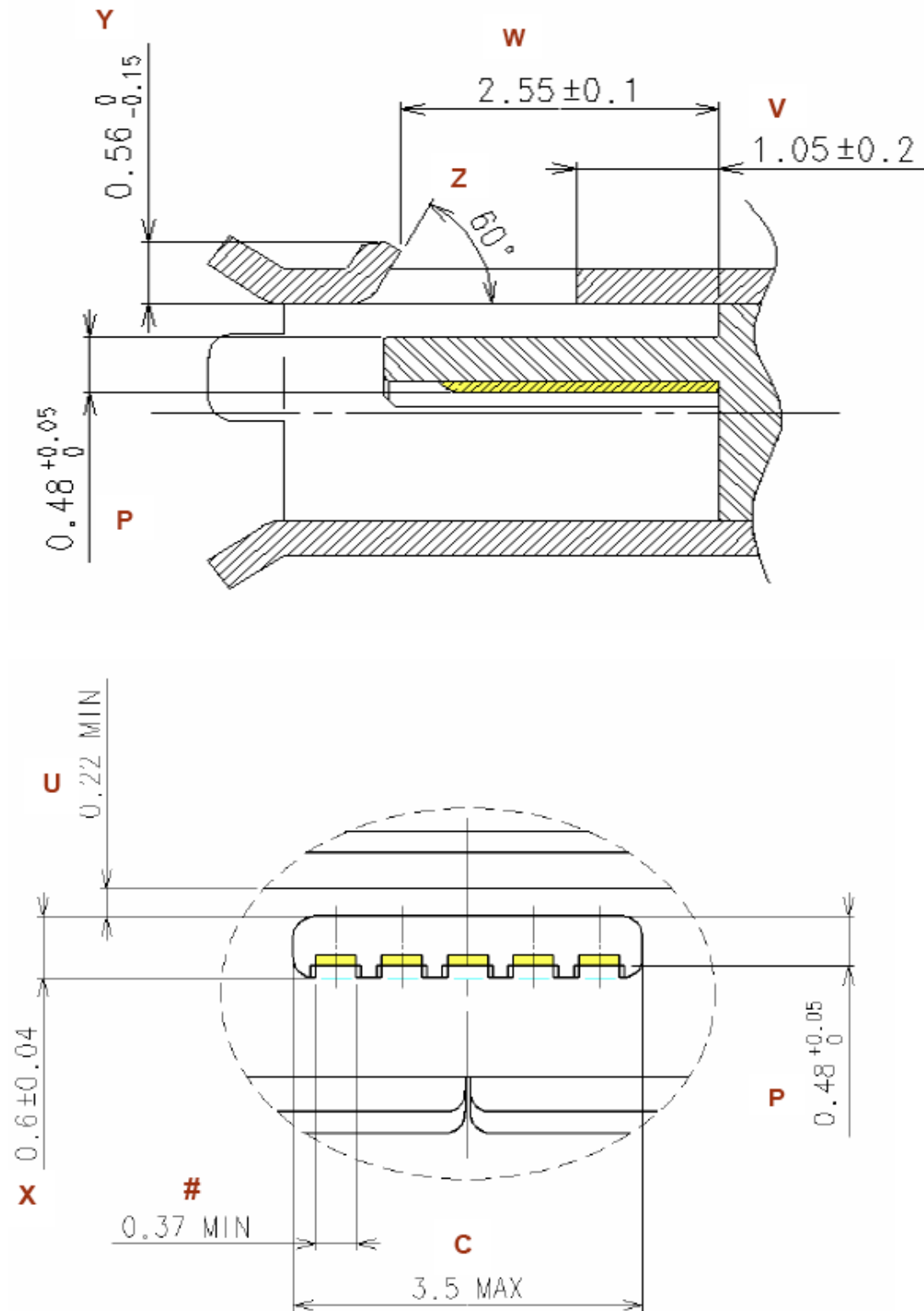

USB 2.0 Group 7 – Micro-USB AB-Receptacle

<u>Description</u>		<u>Dimension</u>	<u>+ tolerance</u>	<u>- tolerance</u>
Rece inside width	M	6.9	0.06	-0.02
Rece inside height -Left	N	1.85	0.08	-0.02
Rece inside height -Right	N	1.85	0.08	-0.02
Plastic width	C	3.5	0	n/a
Plastic height	X	0.6	0.04	-0.04
Plastic from shell	U	0.22	n/a	0
Contacts from plastic	P	0.48	0.05	0
Latch separation	S	4.75	0.05	-0.05
Latch width -Left	T	0.6	n/a	0
Latch width -Right	T	0.6	n/a	0
Latch recess	V	1.05	0.2	-0.2
Latch recess	W	2.55	0.1	-0.1
Latch height	Y	0.56	0	-0.15
Latch Angle	Z	60		
Pin 1 - 5 separation	H	2.6	0.05	-0.05
Pin 2 - 4 separation	I	1.3	0.05	-0.05
Contacts width	#	0.37	0.1	0

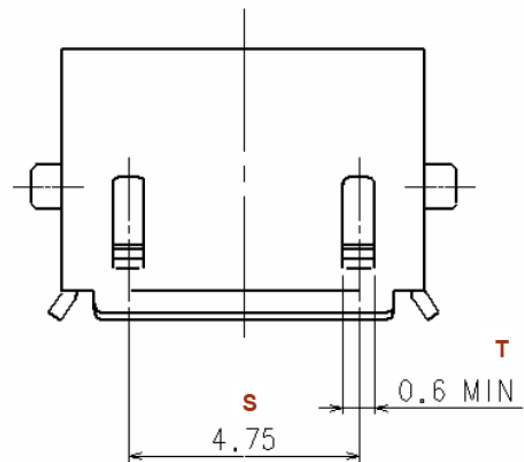
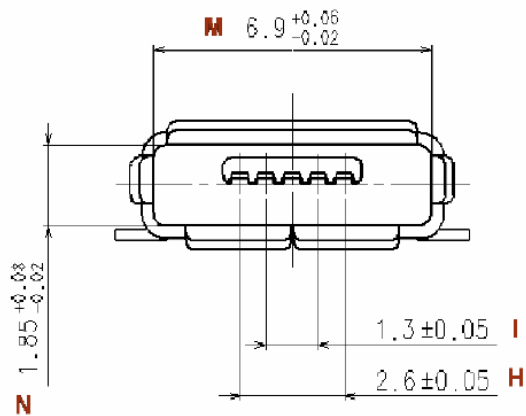

USB 2.0 Group 7 – Micro-USB AB-Receptacle, Continued

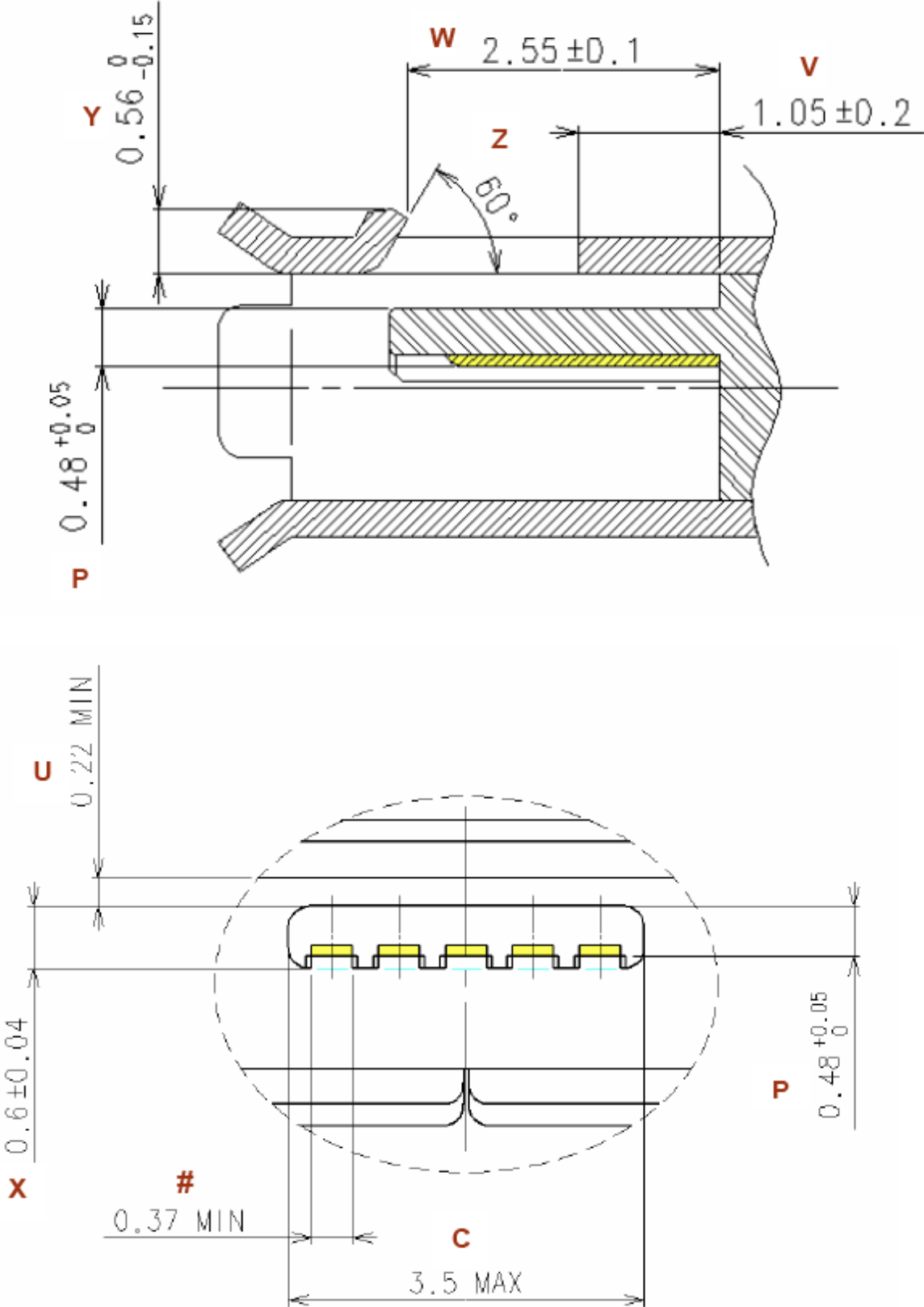

C Attenuation Table

The signal pair attenuation shall not be more than the values shown for the test frequencies in the table below.

Frequency MHz	Attenuation (Maximum) dB/cable ±10%
12.00	0.67
24.00	0.95
48.00	1.35
96.00	1.90
200.00	3.20
400.00	5.80

D 4-Axis Continuity Test

Micro Series plugs and cables with Micro Series plugs shall be tested for continuity under stress using the test configuration shown below. Plugs must be supplied in a cable assembly with a representative overmold. A Micro-AB receptacle shall be mounted on a 2-layer fiberglass printed circuit board of between 0.8 and 1.0 mm thickness. The PC board shall be clamped on either side of the receptacle no further than 5mm away from the solder tails. The PC board shall initially be placed in a horizontal plane, and an 8-Newton tensile force shall be applied to the cable in a downward direction, perpendicular to the axis of insertion, for a period of at least 10 seconds. The continuity across each of the 5 contacts shall be measured throughout the application of the tensile force. The circuit board shall then be rotated 90 degrees such that the cable is still inserted horizontally and the 8-Newton tensile force will be applied again in the downward direction and continuity measured as before. This test will be repeated for 180 and 270 degree rotations. Passing cables will exhibit no discontinuities of greater than 1 microsecond duration in any of the four orientations.

One method for measuring the continuity through the 5 contacts is to short all 4 wires at the end of the cable pigtail. Then on the PC board apply a voltage through a pull-up to each of VBus, D+, D-, and ID pins, with the GND pin connected to ground. When testing a Micro-A plug, all four sense resistors must stay pulled down for the length of the test. When testing a Micro-B plug, the ID pin must stay high and the other pins must remain low for the duration of the test. Test houses may use another method to verify continuity through all 5 pins if they choose.

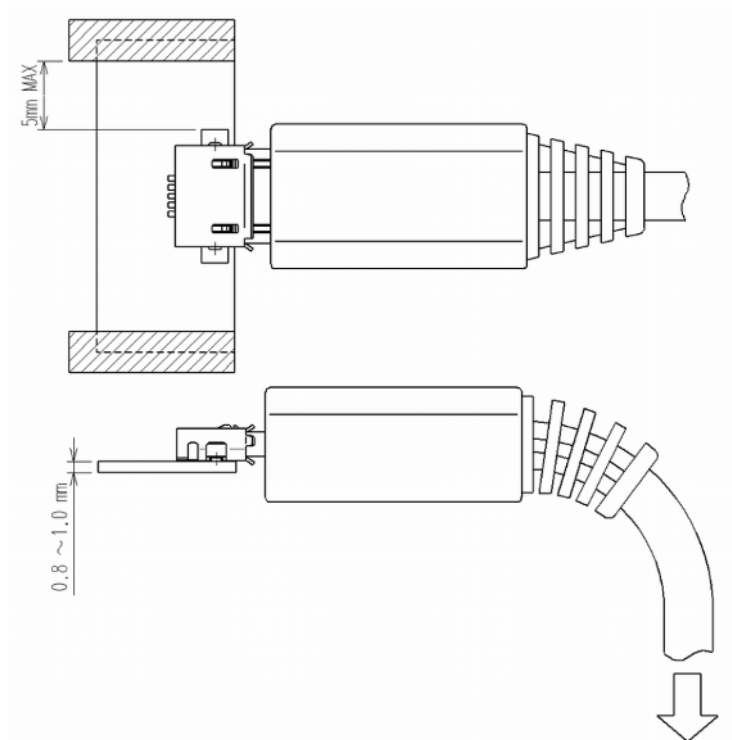

British Standards Institution (BSI)

BSI is the national body responsible for preparing British Standards and other standards-related publications, information and services.

BSI is incorporated by Royal Charter. British Standards and other standardization products are published by BSI Standards Limited.

About us

We bring together business, industry, government, consumers, innovators and others to shape their combined experience and expertise into standards-based solutions.

The knowledge embodied in our standards has been carefully assembled in a dependable format and refined through our open consultation process. Organizations of all sizes and across all sectors choose standards to help them achieve their goals.

Information on standards

We can provide you with the knowledge that your organization needs to succeed. Find out more about British Standards by visiting our website at bsigroup.com/standards or contacting our Customer Services team or Knowledge Centre.

Buying standards

You can buy and download PDF versions of BSI publications, including British and adopted European and international standards, through our website at bsigroup.com/shop, where hard copies can also be purchased.

If you need international and foreign standards from other Standards Development Organizations, hard copies can be ordered from our Customer Services team.

Subscriptions

Our range of subscription services are designed to make using standards easier for you. For further information on our subscription products go to bsigroup.com/subscriptions.

With **British Standards Online (BSOL)** you'll have instant access to over 55,000 British and adopted European and international standards from your desktop. It's available 24/7 and is refreshed daily so you'll always be up to date.

You can keep in touch with standards developments and receive substantial discounts on the purchase price of standards, both in single copy and subscription format, by becoming a **BSI Subscribing Member**.

PLUS is an updating service exclusive to BSI Subscribing Members. You will automatically receive the latest hard copy of your standards when they're revised or replaced.

To find out more about becoming a BSI Subscribing Member and the benefits of membership, please visit bsigroup.com/shop.

With a **Multi-User Network Licence (MUNL)** you are able to host standards publications on your intranet. Licences can cover as few or as many users as you wish. With updates supplied as soon as they're available, you can be sure your documentation is current. For further information, email bsmusales@bsigroup.com.

BSI Group Headquarters

389 Chiswick High Road London W4 4AL UK

Revisions

Our British Standards and other publications are updated by amendment or revision.

We continually improve the quality of our products and services to benefit your business. If you find an inaccuracy or ambiguity within a British Standard or other BSI publication please inform the Knowledge Centre.

Copyright

All the data, software and documentation set out in all British Standards and other BSI publications are the property of and copyrighted by BSI, or some person or entity that owns copyright in the information used (such as the international standardization bodies) and has formally licensed such information to BSI for commercial publication and use. Except as permitted under the Copyright, Designs and Patents Act 1988 no extract may be reproduced, stored in a retrieval system or transmitted in any form or by any means – electronic, photocopying, recording or otherwise – without prior written permission from BSI. Details and advice can be obtained from the Copyright & Licensing Department.

Useful Contacts:

Customer Services

Tel: +44 845 086 9001

Email (orders): orders@bsigroup.com

Email (enquiries): cservices@bsigroup.com

Subscriptions

Tel: +44 845 086 9001

Email: subscriptions@bsigroup.com

Knowledge Centre

Tel: +44 20 8996 7004

Email: knowledgecentre@bsigroup.com

Copyright & Licensing

Tel: +44 20 8996 7070

Email: copyright@bsigroup.com



...making excellence a habit.™