

BS EN 62680-2:2013



BSI Standards Publication

Universal serial bus interfaces for data and power

Part 2: Universal serial bus —
Micro-USB cables and connectors
specification, revision 1.01

bsi.

...making excellence a habit.™

National foreword

This British Standard is the UK implementation of EN 62680-2:2013. It is identical to IEC 62680-2:2013.

The UK participation in its preparation was entrusted to Technical Committee EPL/100, Audio, video and multimedia systems and equipment.

A list of organizations represented on this committee can be obtained on request to its secretary.

This publication does not purport to include all the necessary provisions of a contract. Users are responsible for its correct application.

© The British Standards Institution 2014.
Published by BSI Standards Limited 2014

ISBN 978 0 580 79854 2
ICS 33.120; 35.200

Compliance with a British Standard cannot confer immunity from legal obligations.

This British Standard was published under the authority of the Standards Policy and Strategy Committee on 28 February 2014.

Amendments /corrigenda issued since publication

Date	Text affected
-------------	----------------------

**Universal serial bus interfaces for data and power -
Part 2: Universal serial bus -
Micro-USB cables and connectors specification, revision 1.01
(IEC 62680-2:2013)**

Interfaces de bus universel en série pour les données et l'alimentation électrique -
Partie 2: Bus universel en série -
Spécification des câbles et connecteurs micro-USB, révision 1.01
(CEI 62680-2:2013)

Schnittstellen des Universellen Seriellen Busses für Daten und Energie -
Teil 2: Festlegung für USB-Mikro-USB-Kabel und Steckverbinder
(IEC 62680-2:2013)

This European Standard was approved by CENELEC on 2013-10-16. CENELEC members are bound to comply with the CEN/CENELEC Internal Regulations which stipulate the conditions for giving this European Standard the status of a national standard without any alteration.

Up-to-date lists and bibliographical references concerning such national standards may be obtained on application to the CEN-CENELEC Management Centre or to any CENELEC member.

This European Standard exists in three official versions (English, French, German). A version in any other language made by translation under the responsibility of a CENELEC member into its own language and notified to the CEN-CENELEC Management Centre has the same status as the official versions.

CENELEC members are the national electrotechnical committees of Austria, Belgium, Bulgaria, Croatia, Cyprus, the Czech Republic, Denmark, Estonia, Finland, Former Yugoslav Republic of Macedonia, France, Germany, Greece, Hungary, Iceland, Ireland, Italy, Latvia, Lithuania, Luxembourg, Malta, the Netherlands, Norway, Poland, Portugal, Romania, Slovakia, Slovenia, Spain, Sweden, Switzerland, Turkey and the United Kingdom.

CENELEC

European Committee for Electrotechnical Standardization
Comité Européen de Normalisation Electrotechnique
Europäisches Komitee für Elektrotechnische Normung

CEN-CENELEC Management Centre: Avenue Marnix 17, B - 1000 Brussels

Foreword

The text of document 100/2153/FDIS, future edition 1 of IEC 62680-2, prepared by IEC/TC 100, "Audio, video and multimedia systems and equipment" was submitted to the IEC-CENELEC parallel vote and approved by CENELEC as EN 62680-2:2013.

The following dates are fixed:

- latest date by which the document has to be implemented at national level by publication of an identical national standard or by endorsement (dop) 2014-07-16
- latest date by which the national standards conflicting with the document have to be withdrawn (dow) 2016-10-16

Attention is drawn to the possibility that some of the elements of this document may be the subject of patent rights. CENELEC [and/or CEN] shall not be held responsible for identifying any or all such patent rights.

Endorsement notice

The text of the International Standard IEC 62680-2:2013 was approved by CENELEC as a European Standard without any modification.

INTRODUCTION

The IEC 62680 series is based on a series of specifications that were originally developed by the USB Implementers Forum (USB-IF). These specifications were submitted to the IEC under the auspices of a special agreement between the IEC and the USB-IF.

The USB Implementers Forum, Inc.(USB-IF) is a non-profit corporation founded by the group of companies that developed the Universal Serial Bus specification. The USB-IF was formed to provide a support organization and forum for the advancement and adoption of Universal Serial Bus technology. The Forum facilitates the development of high-quality compatible USB peripherals (devices), and promotes the benefits of USB and the quality of products that have passed compliance testing.

ANY USB SPECIFICATIONS ARE PROVIDED TO YOU "AS IS, "WITH NO WARRANTIES WHATSOEVER, INCLUDING ANY WARRANTY OF MERCHANTABILITY, NON-INFRINGEMENT, OR FITNESS FOR ANY PARTICULAR PURPOSE. THE USB IMPLEMENTERS FORUM AND THE AUTHORS OF ANY USB SPECIFICATIONS DISCLAIM ALL LIABILITY, INCLUDING LIABILITY FOR INFRINGEMENT OF ANY PROPRIETARY RIGHTS, RELATING TO USE OR IMPLEMENTATION OR INFORMATION IN THIS SPECIFICATION.

THE PROVISION OF ANY USB SPECIFICATIONS TO YOU DOES NOT PROVIDE YOU WITH ANY LICENSE, EXPRESS OR IMPLIED, BY ESTOPPEL OR OTHERWISE, TO ANY INTELLECTUAL PROPERTY RIGHTS.

Entering into USB Adopters Agreements may, however, allow a signing company to participate in a reciprocal, royalty-free licensing arrangement for compliant products. For more information, please see:

<http://www.usb.org/developers/docs/>

http://www.usb.org/developers/devclass_docs#approved

IEC DOES NOT TAKE ANY POSITION AS TO WHETHER IT IS ADVISABLE FOR YOU TO ENTER INTO ANY USB ADOPTERS AGREEMENTS OR TO PARTICIPATE IN THE USB IMPLEMENTERS FORUM.”

This series covers the Universal Serial Bus interfaces for data and power and consists of the following parts:

IEC 62680-1, *Universal Serial Bus interfaces for data and power – Part 1: Universal Serial Bus Specification, Revision 2.0*

IEC 62680-2, *Universal Serial Bus interfaces for data and power – Part 2: USB Micro-USB Cables and Connectors Specification, Revision 1.01*

IEC 62680-3, *Universal Serial Bus interfaces for data and power – Part 3: USB Battery Charging Specification, Revision 1.2*

IEC 62680-4, *Universal Serial Bus interfaces for data and power – Part 4: Universal Serial Bus Cables and Connectors Class Document Revision. 2.0*

This part of the IEC 62680 series consists of several distinct parts:

- the main body of the text, which consists of the original specification and all ECN and Errata developed by the USB-IF.

CONTENTS

1	Introduction	10
1.1	General	10
1.2	Objective of the Specification	10
1.3	Intended Audience/Scope	10
1.4	Related Documents	10
2	Acronyms and Terms	10
3	Significant Features	11
3.1	USB 2.0 Specification Compliance	11
3.2	On-The-Go Device	11
3.3	Connectors	11
3.4	Compliant Cable Assemblies	12
3.5	Plug Overmolds	12
4	Cables and Connectors	12
4.1	Introduction	12
4.2	Micro-Connector Mating	12
4.3	Color Coding	13
4.4	Device, Cable and Adapter Delays	13
4.5	Compliant Usage of Connectors and Cables	14
4.5.1	Cables	14
4.5.2	Overmolds	14
4.5.3	Mechanical Interfaces	14
4.5.4	Surface mount standard version drawings	14
4.5.5	DIP-type and Midmount-type receptacles	14
4.5.6	Connector Keying	15
4.5.7	Right Angle Plugs	15
4.5.8	Adapters	15
4.6	Drawings	15
5	Electrical Compliance Requirements	34
5.1	Data Rates Beyond USB 2.0 (480Mb/s -->)	35
5.2	Low Level Contact Resistance	35
5.3	Contact Current Rating	35
5.3.1	Signal Contacts Only (2, 3, and 4)	35
5.3.2	With Power Applied Contacts (1 and 5)	35
6	Mechanical Compliance Requirements	35
6.1	Operating Temperature Range	35
6.1.1	Option I	35
	Option II	35
6.2	Insertion Force	35
6.3	Extraction Force	35
6.4	Plating	35
6.4.1	Option I	36
6.4.2	Option II	36
6.5	Solderability	36
6.6	Peel Strength (Reference Only)	36
6.7	Wrenching Strength (Reference Only)	36
6.8	Lead Co-Planarity	36
6.9	RoHS Compliance	36

6.10 Shell & Latch Materials..... 36

Note: All Engineering Change Notice's (ECN) and Errata documents as of September 01, 2012 that pertain to this core specification follow the last page of the specification starting on page 37.

Universal Serial Bus Micro-USB Cables and Connectors Specification

Revision 1.01
April 4, 2007

Revision History

Revision	Issue Date	Comment
0.6	1/30/2006	Revisions to all sections
0.7	3/24/2006	Added revised Micro-USB drawings to Rev.0.8
0.8	4/19/2006	Editorial changes and additions by Jan Fahlund (Nokia)
0.8b	4/26/2006	Corrections to the 0.8 version (based by comments from contributors)
0.9	6/7/2006	Corrections based on comments from the 0.8b version
1.0RC	8/2/2006	Added lubricant recommendation, LLRC delta change specified
1.01RC	11/10/2006	Editorial changes and addition based on Oct-06 USB-IF CCWG meeting.
1.02RC	12/10/2006	Shell material thickness tolerances changed so that material can be 0.25 mm or 0.3 mm; edited three pictures (Figure 4-10, 4-11 and 4-12).
1.03RC	12/11/2006	Two pictures edited (Figure 4-8 and 4-9). In fig 4-8 max height to be 2.8mm MAX. In fig 4-9 R0.25mm MAX to be R0.30mm MAX.
1.0RC3	12/19/2006	For BoD approval
1.0	1/12/2007	Approved
1.0	1/22/2007	Cosmetic edits for publication
1.01	4/4/2007	Editorial corrections and additions to contributor list. Reinserted shell and plug material requirements as section 6.10. Clarified wording on Plating Recommendations.

Copyright © 2006 USB Implementers Forum, Inc. (USB-IF).
All rights reserved.

A LICENSE IS HEREBY GRANTED TO REPRODUCE THIS SPECIFICATION FOR INTERNAL USE ONLY. NO OTHER LICENSE, EXPRESS OR IMPLIED, BY ESTOPPEL OR OTHERWISE, IS GRANTED OR INTENDED HEREBY.

USB-IF AND THE AUTHORS OF THIS SPECIFICATION EXPRESSLY DISCLAIM ALL LIABILITY FOR INFRINGEMENT OF INTELLECTUAL PROPERTY RIGHTS, RELATING TO IMPLEMENTATION OF INFORMATION IN THIS SPECIFICATION. USB-IF AND THE AUTHORS OF THIS SPECIFICATION ALSO DO NOT WARRANT OR REPRESENT THAT SUCH IMPLEMENTATION(S) WILL NOT INFRINGE THE INTELLECTUAL PROPERTY RIGHTS OF OTHERS.

THIS SPECIFICATION IS PROVIDED "AS IS" AND WITH NO WARRANTIES, EXPRESS OR IMPLIED, STATUTORY OR OTHERWISE. ALL WARRANTIES ARE EXPRESSLY DISCLAIMED. NO WARRANTY OF MERCHANTABILITY, NO WARRANTY OF NON-INFRINGEMENT, NO WARRANTY OF FITNESS FOR ANY PARTICULAR PURPOSE, AND NO WARRANTY ARISING OUT OF ANY PROPOSAL, SPECIFICATION, OR SAMPLE.

IN NO EVENT WILL USB-IF OR USB-IF MEMBERS BE LIABLE TO ANOTHER FOR THE COST OF PROCURING SUBSTITUTE GOODS OR SERVICES, LOST PROFITS, LOSS OF USE, LOSS OF DATA OR ANY INCIDENTAL, CONSEQUENTIAL, INDIRECT, OR SPECIAL DAMAGES, WHETHER UNDER CONTRACT, TORT, WARRANTY, OR OTHERWISE, ARISING IN ANY WAY OUT OF THE USE OF THIS SPECIFICATION, WHETHER OR NOT SUCH PARTY HAD ADVANCE NOTICE OF THE POSSIBILITY OF SUCH DAMAGES.

All product names are trademarks, registered trademarks, or service marks of their respective owners.

Contributors

Mark Rodda, (editor) Motorola

Jan Fahllund, (editor) Nokia

Jim Koser, (CCWG Chairman), Foxconn

Ed Beeman, 2010 Tech

Glen Chandler, Advanced-Connectek (Acon)

Charles Wang, Advanced-Connectek (Acon)

Toshinori Sasaki, Across Techno

Minoru Ohara, Allion

Brad Brown, ATL

Christopher Mattson, ATL

Marcus Darrington, ATL

Jaremy Flake, ATL Technology

George Olear, Contech Research

Roy Ting, Elka

Sophia Liu, ETC

Bill Northey, FCI

Tsuneki Watanabe, Foxconn

Jim Zhao, Foxconn

David Ko, Foxconn

Jong Tseng, Foxconn

Jack Lu, Foxlink

Tim Chang, Foxlink

Sathid Inthon, Fujikura

Toshi Mimura, Fujijura

Alan Berkema, Hewlett-Packard

Karl Kwiat, Hirose

Shinya Tono, Hirose

Kazu Ichikawa, Hirose

Ryozo Koyama, Hirose

Yousuke Takeuchi, Hirose

Tsuyoshi Kitagawa, Hosiden

Jim Eilers, Hosiden

Kazuhiro Saito, JAE

Ron Muir, JAE

Mark Saubert, JAE

Yasuhira Miya, JST

Takahiro Diguchi, JST

Yoichi Nakazawa, JST

Kevin Fang, Longwell Electronics

Morgan Jair, Main Super Co.

Tom Kawaguchi, Matsushita Electric Works

Ron Ward, Matsushita Electric Works

Satoshi Yamamoto, Matsushita Electric Works

Yasuhiko Shinohara, Mitsumi

Atsushi Nishio, Mitsumi

Hitoshi Kawamura, Mitsumi

Scott Sommers, Molex

Kevin Delaney, Molex

Kieran Wright, Molex

Padraig McDaid, Molex

Mikko Poikselka, Molex

Sam Liu, Newnex Technology Corp.

Richard Petrie, Nokia

Kai Silvennoinen, Nokia

Panu Ylihaavisto, Nokia

Arthur Zarnowitz, Palm

Douglas Riemer, SMK

Eric Yagi, SMK

Abid Hussain, Summit Microelectronics

Kaz Osada, Tyco

Masaru Ueno, Tyco

Yoshikazu Hirata, Tyco

Mark Paxson, VTM Inc.

1 Introduction

1.1 General

USB has become a popular interface for exchanging data between cell phone and portable devices. Many of these devices have become so small it is impossible to use standard USB components as defined in the USB 2.0 specification. In addition the durability requirements of the Cell Phone and Portable Devices market exceed the specifications of the current interconnects. Since Cell Phones and other small Portable Devices are the largest market potential for USB, this specification is addressing this very large market while meeting all the requirements for electrical performance within the USB 2.0 specification.

1.2 Objective of the Specification

The purpose of this document is to define the requirements and features of a Micro-USB connector that will meet the current and future needs of the Cell Phone and Portable Devices markets, while conforming to the USB 2.0 specification for performance, physical size and shape of the Micro-USB interconnect.

This is not a stand-alone document. Any aspects of USB that are not specifically changed by this specification are governed by the USB 2.0 Specification and USB On-The-Go Supplement.

1.3 Intended Audience/Scope

Cell phone and Portable Devices have become so thin that the current Mini-USB does not fit well within the constraints of future designs. Additional requirements for a more rugged connector that will have durability past 10,000 cycles and still meet the USB 2.0 specification for mechanical and electrical performance was also a consideration. The Mini-USB could not be modified and remain backward compatible to the existing connector as defined in the USB OTG specification.

1.4 Related Documents

USB 2.0

USB OTG Supplement

2 Acronyms and Terms

This chapter lists and defines terms and abbreviations used throughout this specification.

A-Device	A device with a Type-A plug inserted into its receptacle. The A-device supplies power to VBUS and is host at the start of a session. If the A-device is On-The-Go, it may relinquish the role of host to an On-The-Go B-device under certain conditions,
Application	A generic term referring to any software that is running on a device that can control the behavior or actions of the USB port(s) on a device.
B-Device	A device with a Type-B plug inserted into its receptacle. The B-device is a peripheral at the start of a session. If the B-device is OTG, it may be granted the role of host from an OTG A-device.
DIP-type	A connector with contact and shield solder tails that are soldered through the printed circuit board
FS	Full Speed (max 12Mb/s)
Higher than HS	(480Mb/s ---> 5 Gb/s)

HS	High Speed (max 480 Mb/s)
Host	A physical entity that is attached to a USB cable and is acting in the role of the USB host as defined in the USB Specification, Revision 2.0. This entity initiates all data transactions and provides periodic Start of Frames.
HNP	Host Negotiation Protocol
ID	Identification. Denotes the pin on the Micro connectors that is used to differentiate a Micro-A plug from a Micro-B plug.
LS	Low Speed (max 1,5 Mb/s)
Midmount-type	A connector that is mounted in a cut-out in the printed circuit board between the top and bottom surfaces.
OTG	On-The-Go
OTG device	A device with the host and peripheral capabilities
Peripheral	A physical entity that is attached to a USB cable and is currently operating as a “device” as defined in the USB Specification, Revision 2.0. The Peripheral responds to low level bus requests from the Host.
PCB	Printed circuit board
USB	Universal Serial Bus
USB-IF	USB Implementers Forum

3 Significant Features

This section identifies the significant features of the Micro-USB specification. The purpose of this section is not to present all the technical details associated with each major feature, but rather to highlight its existence. Where appropriate, this section references other parts of the document where further details can be found.

3.1 USB 2.0 Specification Compliance

Any device with Micro-USB features is first and foremost a USB peripheral that is compliant with the USB 2.0 specification.

3.2 On-The-Go Device

Any OTG Micro-USB device shall conform to the OTG requirements as set forth in the On-The-Go Supplement to the USB 2.0 Specification.

3.3 Connectors

The USB 2.0 specification defines the following connectors:

- Standard-A plug and receptacle,
- Standard-B plug and receptacle, and
- Mini-B plug and receptacle.

The Micro-USB specification defines the following additional connectors:

- Micro-B plug and receptacle
- Micro-AB receptacle
- Micro-A plug.

The Micro-AB receptacle is only allowed on OTG products. All other uses of the Micro-AB receptacle are prohibited. The Micro-AB receptacle accepts either a Micro-A plug or a Micro-B plug.

It is recommended that the Micro-AB continue to support HNP as requested and support full functionality as a peripheral when a Micro-B plug is inserted.

3.4 Compliant Cable Assemblies

The USB 2.0 specification defines the following cables:

- Standard-A plug to Standard-B plug,
- Standard-A plug to Mini-B plug, and
- Captive cable with Standard-A plug.

The Micro-USB specification defines the following additional cables:

- Micro-A plug to Micro-B plug,
- Micro-A plug to Standard-A receptacle
- Micro-B plug to Standard-A plug, and
- Hardwired Captive cable with Micro-A plug. (Hardwired Captive cable is a cable, connected internally to a device, which is not designed to be removed by the end user of that device.)

No other types of cables are allowed by either the USB specification, or by the OTG supplement. Cables are not allowed to have receptacles on either end unless they meet the mechanical and electrical requirements of adapters defined in this document.

3.5 Plug Overmolds

The Micro-USB specification constrains the size and the shape of the overmolds for the Micro-A and Micro-B plugs.

The Micro-A plug's overmold has a rectangular shape, and the Micro-B plug's overmold is rectangular with chamfers. This allows easy recognition and differentiation of the two plugs by the consumer See pictures Figure 4-4 and Figure 4-5.

4 Cables and Connectors

4.1 Introduction

This chapter provides the mechanical and electrical specifications for the cables, connectors and cable assemblies used to interconnect devices as well as constraints on the design of the overmolds for the Micro-A and Micro-B plugs.

4.2 Micro-Connector Mating

The following table summarizes the plugs accepted by each of the receptacles.

Table 4-1. Plugs Accepted By Receptacles

Receptacle	Plugs Accepted
Standard-A	Standard-A
Standard-B	Standard-B
Mini-B	Mini-B
Micro-B	Micro-B
Micro-AB	Micro-A or Micro-B

The usage and wiring assignments of the five pins in the Micro-A plug are defined in the following table.

Table 4-2. Micro-A Plug Pin Assignments

Contact Number	Signal Name	Typical Wiring Assignment
1	VBUS	Red
2	D-	White
3	D+	Green
4	ID	<Ra_PLUG_ID
5	GND	Black
Shell	Shield	Drain Wire

The ID pin on a Micro-A plug shall be connected to the GND pin. The ID pin on a Micro-B plug is not connected or is connected to ground by a resistance of greater than Rb_PLUG_ID (100kΩ MIN). An On-The-Go device is required to be able to detect whether a Micro-A or Micro-B plug is inserted by determining if the ID pin resistance to ground is less than Ra_PLUG_ID (10Ω MAX) or if the resistance to ground is greater than Rb_PLUG_ID. Any ID resistance less than Ra_PLUG_ID shall be treated as ID = FALSE and any resistance greater than Rb_PLUG_ID shall be treated as ID = TRUE.

4.3 Color Coding

The following colors are mandated for the plastic inside the Micro-USB connectors defined in this specification.

Table 4-3. Color Coding for Plugs and Receptacles

Connector	Color
Micro-A plug	White
Micro-B receptacle	Black
Micro-B plug	Black
Micro-AB receptacle	Gray

4.4 Device, Cable and Adapter Delays

In Figure 7-11 of the USB 2.0 specification, four test planes are defined along the transmission path from the host transceivers to the peripheral transceivers. These test planes (TP) are as follows:

- TP1: pins of host transceiver chip
- TP2: contact points of host Standard-A receptacle
- TP3: contact points of peripheral Standard-B or Micro-B receptacle
- TP4: pins of peripheral transceiver chip

The maximum total delays are as follows:

- On-The-Go device - TP1 to TP2: 1 ns
- Adapter: 1 ns
- Any cable with a Micro-A or Micro-B plug: 10 ns

The maximum delays for the two worst cases of connection are shown in the following tables.

Table 4-4. Maximum Delay for Micro-Connector and Cable

Location	Delay Time
USB 2.0 Compliant Host – TP1 to TP2	3 ns
Standard-A receptacle to Micro-A plug adapter	1 ns
Micro-A plug to Micro-B plug cable	10 ns
USB 2.0 Compliant B-device – TP3-TP4	1 ns
Total	15 ns

Table 4-5. Maximum Delay for Standard Connector Cable

Location	Delay Time
On-The-Go Compliant Device – TP1 to TP2	1 ns
Micro-A plug to Standard-A receptacle adapter	1 ns
Standard-A plug to Standard-B plug cable	26 ns
USB 2.0 Compliant B-device – TP3 to TP4	1 ns
Total	29 ns

4.5 Compliant Usage of Connectors and Cables

Cable assemblies and connectors not described below or not allowed by other amendments to the USB specification are not compliant with the USB specification and may not be labeled as such.

4.5.1 Cables

The cables allowed by the Micro-USB specification are shown in Figure 4-1 – Micro-A to Micro-B Cable, Figure 4-2, and Figure 4-3. Cables must have a propagation delay of 10 ns or less, have a physical length of no more than 2.0 meters, and meet all other requirements of a USB cable.

4.5.2 Overmolds

The size and shape of the Micro-A and Micro-B plug overmolds must conform to the constraints shown in Figure 4-4 and Figure 4-5 .

4.5.3 Mechanical Interfaces)

The mechanical interface dimensions for the Micro-A and Micro-B plugs are shown in Figure 4-6 and Figure 4-7. Mechanical interface dimensions for Micro-AB and Micro-B receptacles are shown in Figure 4-9 and Figure 4-10.

4.5.4 Surface mount standard version drawings

By following these instructions, receptacles from different manufacturers can be used interchangeably on the same printed circuit board (PCB). In the case of the "surface mount standard version", the dimensions of the contact tail and shield tail must comply with figures 4-11 and 4-12.

Note: PCB-layout drawings are included for reference only.

Figure 4-11 and Figure 4-12 shows designs for the Micro-AB and Micro-B receptacles respectively.

4.5.5 DIP-type and Midmount-type receptacles

DIP-type (contact and shield tails soldered through PCB) and Midmount-type (connector that is mounted in a cut-out in the printed circuit board between the top and bottom surfaces.) receptacle connectors are not defined in this standards document. These mounting styles are allowed under the standard as long as all intermating conditions are met. Mechanical

dimensions and mechanical durability values may vary from the Surface mount standard connector but must comply with all minimum values.

4.5.6 Connector Keying

This Micro connector series has been designed so as to prevent the Micro-A and Micro-B plugs from being incorrectly inserted into a receptacle. The amount of metal blocking various possible incorrect insertions is shown in Figure 4-13 and Figure 4-14, and is always greater than 0.35 mm.

4.5.7 Right Angle Plugs

The overmolds for right / down angle plugs are required to comply with the same shape constraints that apply to straight plugs. Reference drawings for right / down angle plugs are shown in Figure 4-15, Figure 4-16, Figure 4-17 and Figure 4-18 .

4.5.8 Adapters

Requirements:

- The propagation delay of the adapter shall be less than 1 ns.
- The physical length shall not exceed 150 mm.
- The resistance of the adapter through VBUS and GND, including contacts, shall not exceed 70 mΩ.

4.5.8.1 Standard-A receptacle to Micro-A plug

This adapter is used to connect a cable with a Standard-A plug to an On-The-Go device that has a Micro-AB receptacle. A reference drawing for this adapter is shown in Figure 4-19(Figure 4-18).

4.6 Drawings

This section contains the mechanical drawings that are referenced in the previous section.

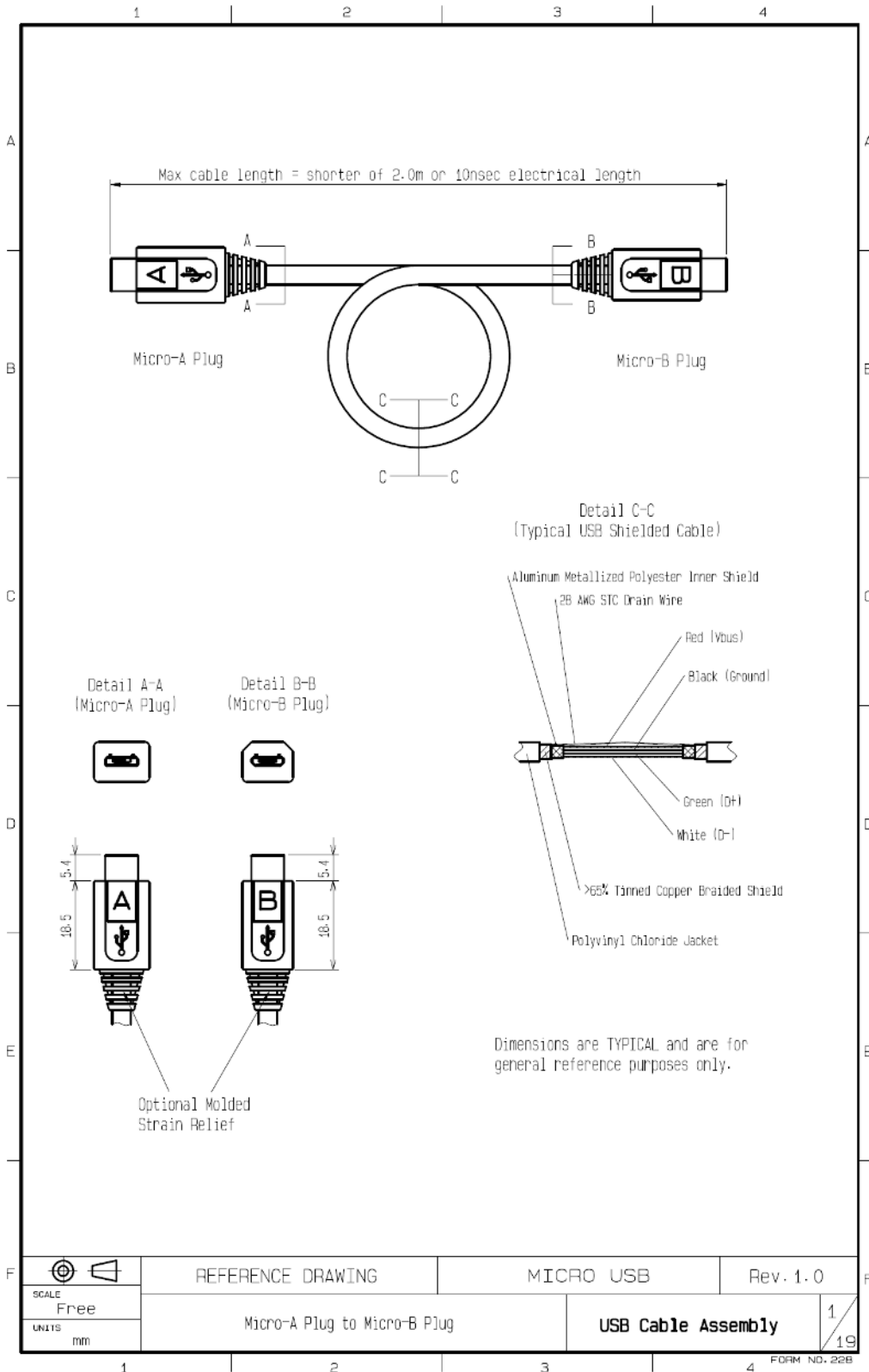

Figure 4-1 – Micro-A to Micro-B Cable

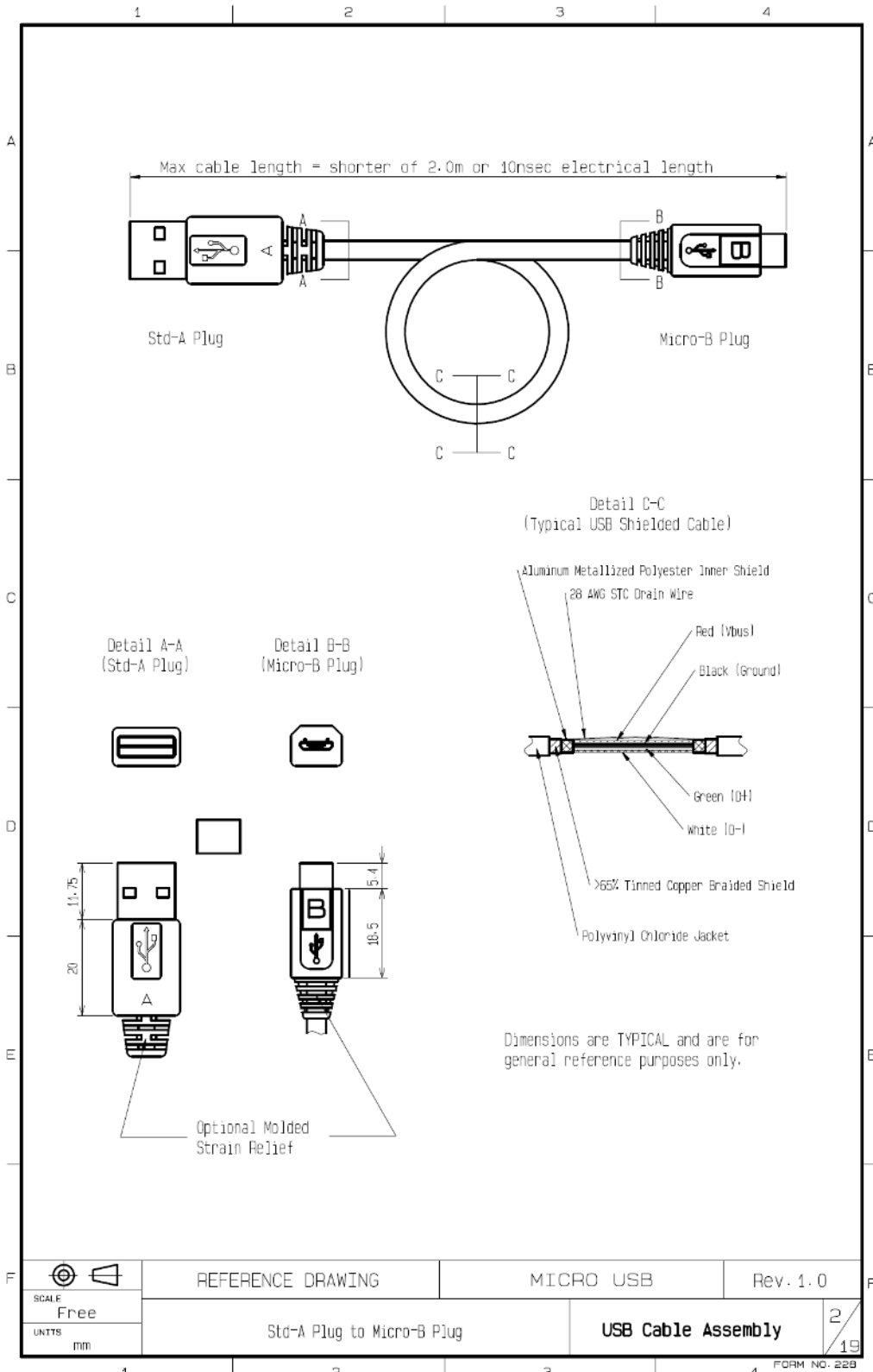

Figure 4-2 Standard-A to Micro-B Cable

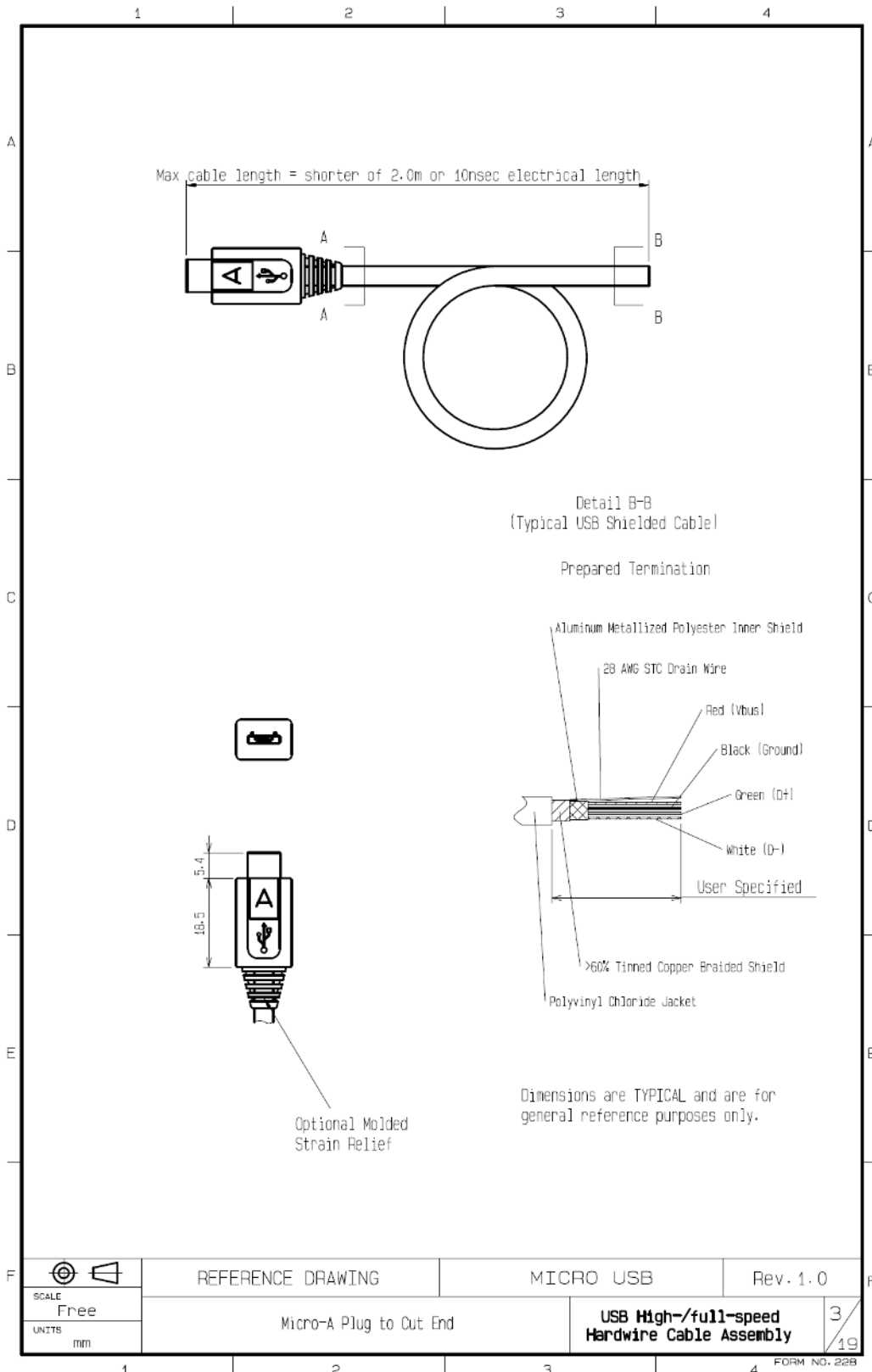

Figure 4-3 Micro-A to Captive Cable

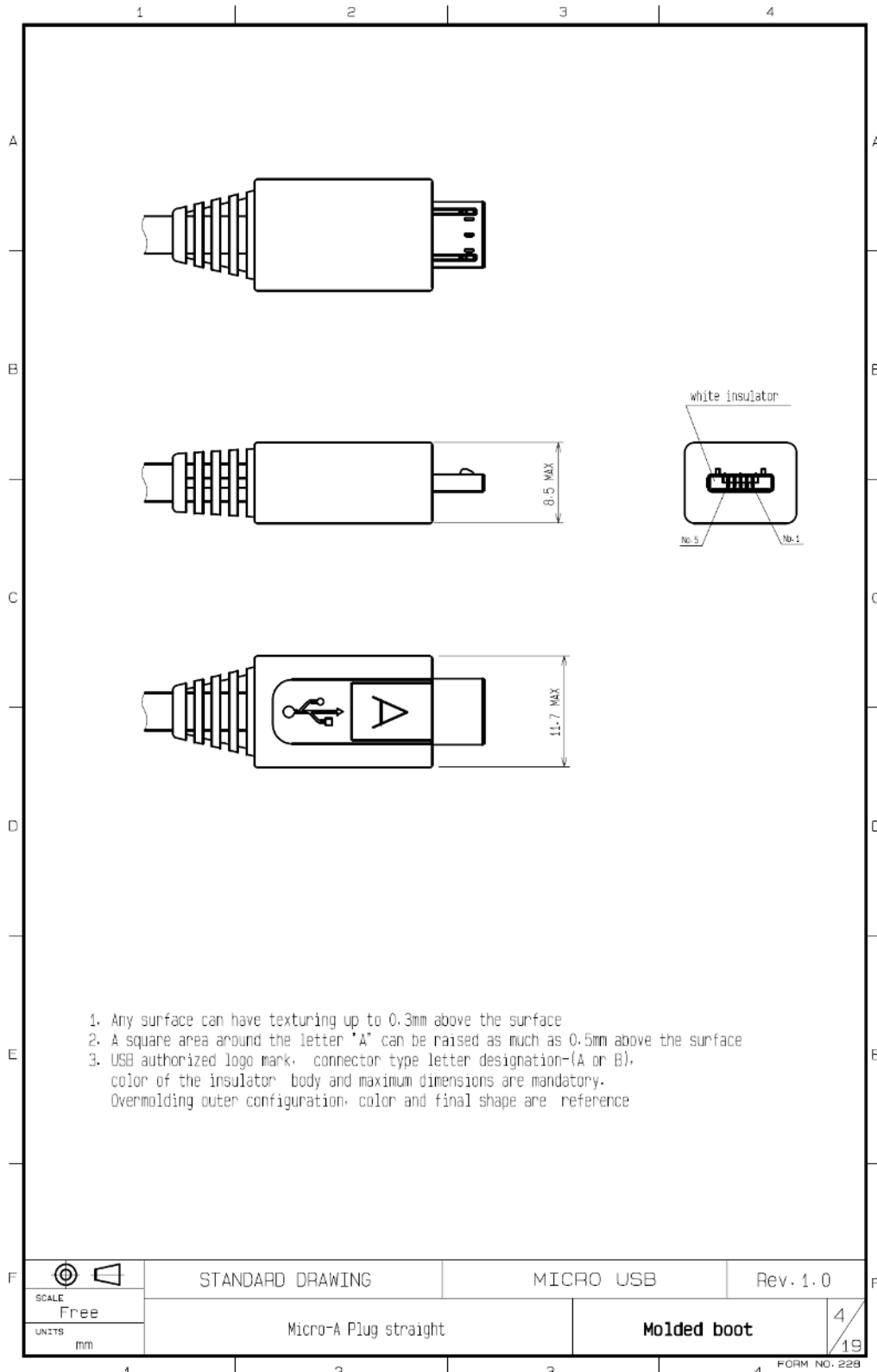

Figure 4-4 Micro-A Plug Overmold, Straight

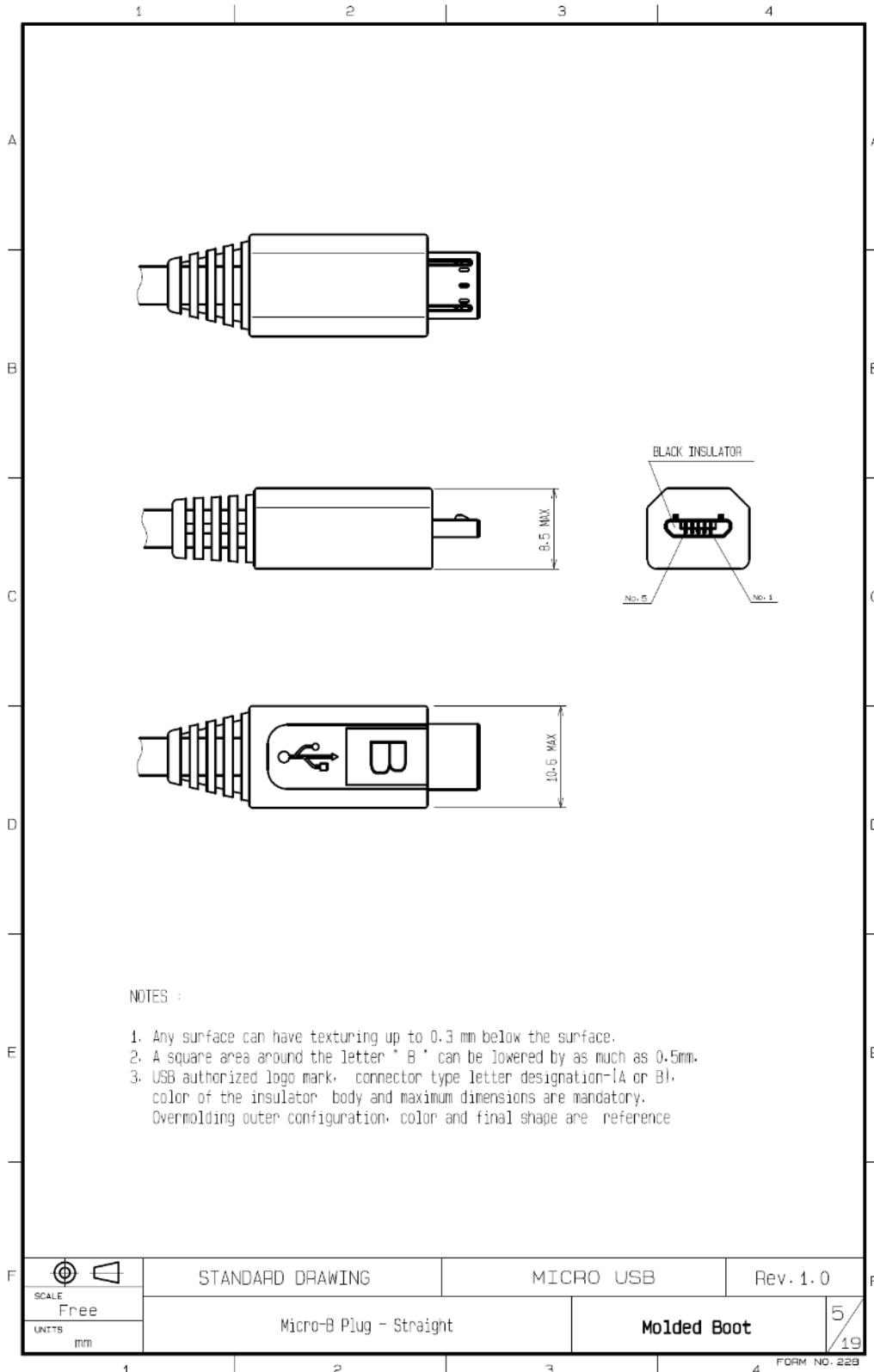

Figure 4-5 Micro-B Plug Overmold, Straight

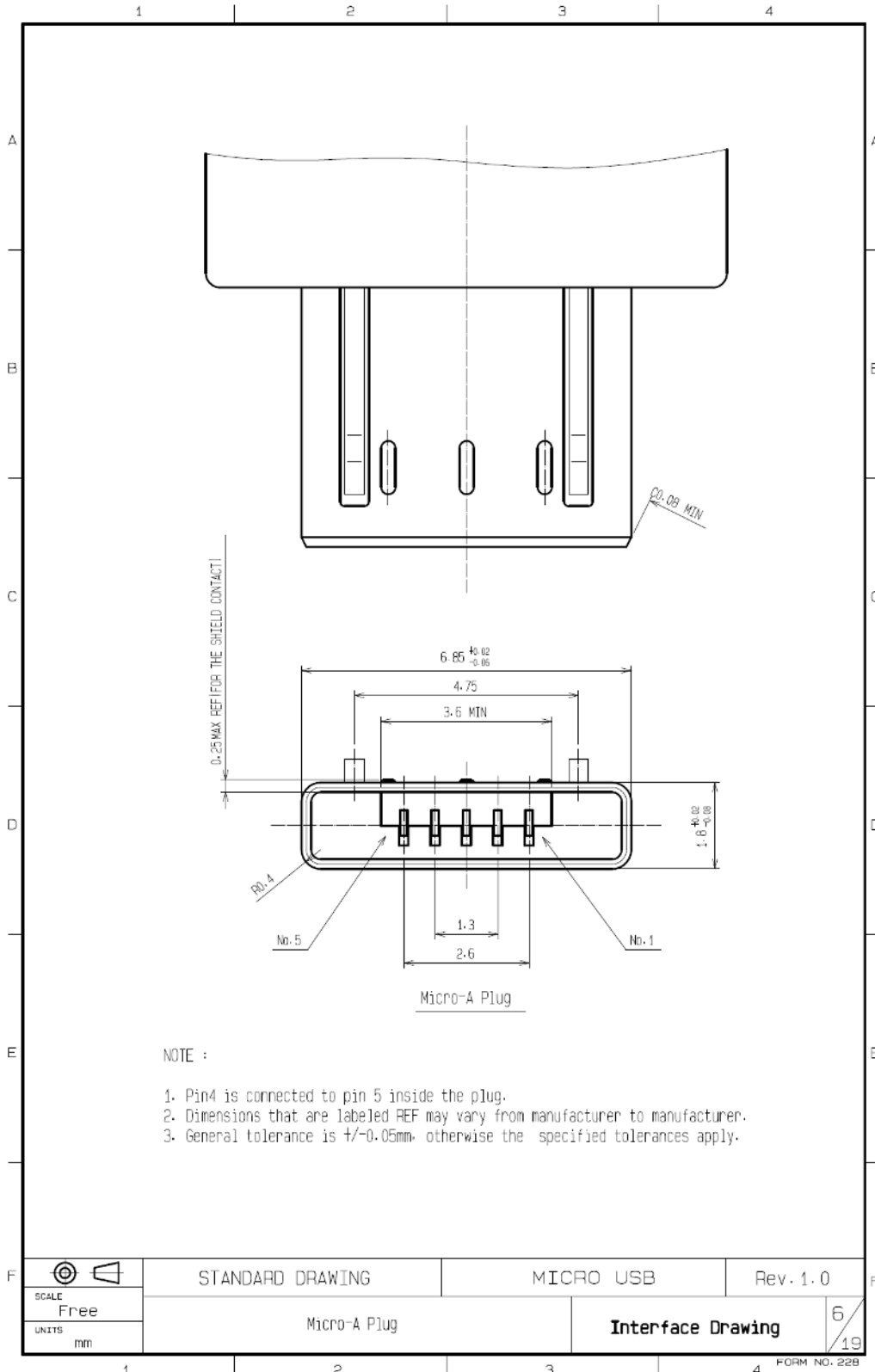

Figure 4-6 Micro-A Plug Interface

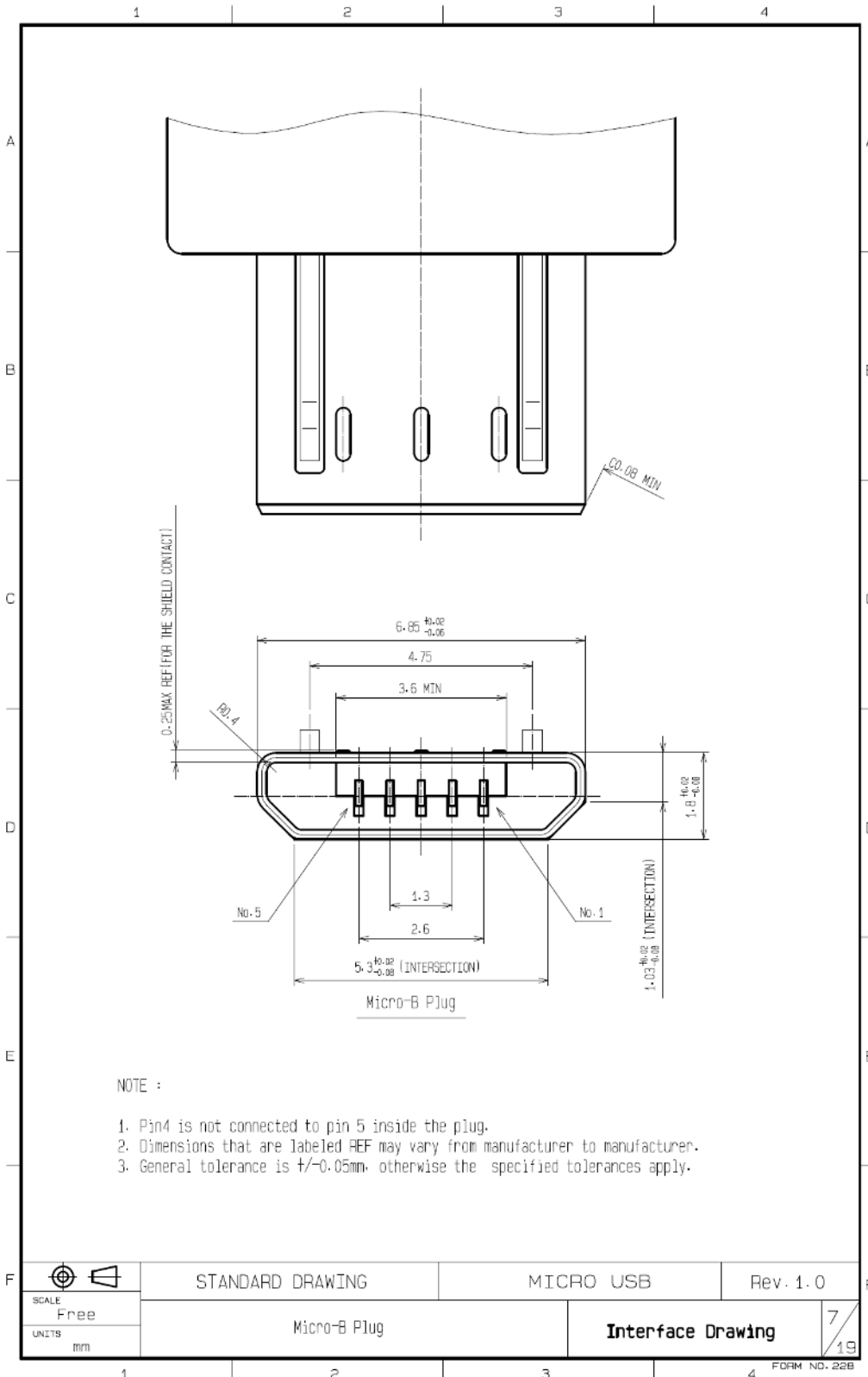

Figure 4-7 Micro-B Plug Interface

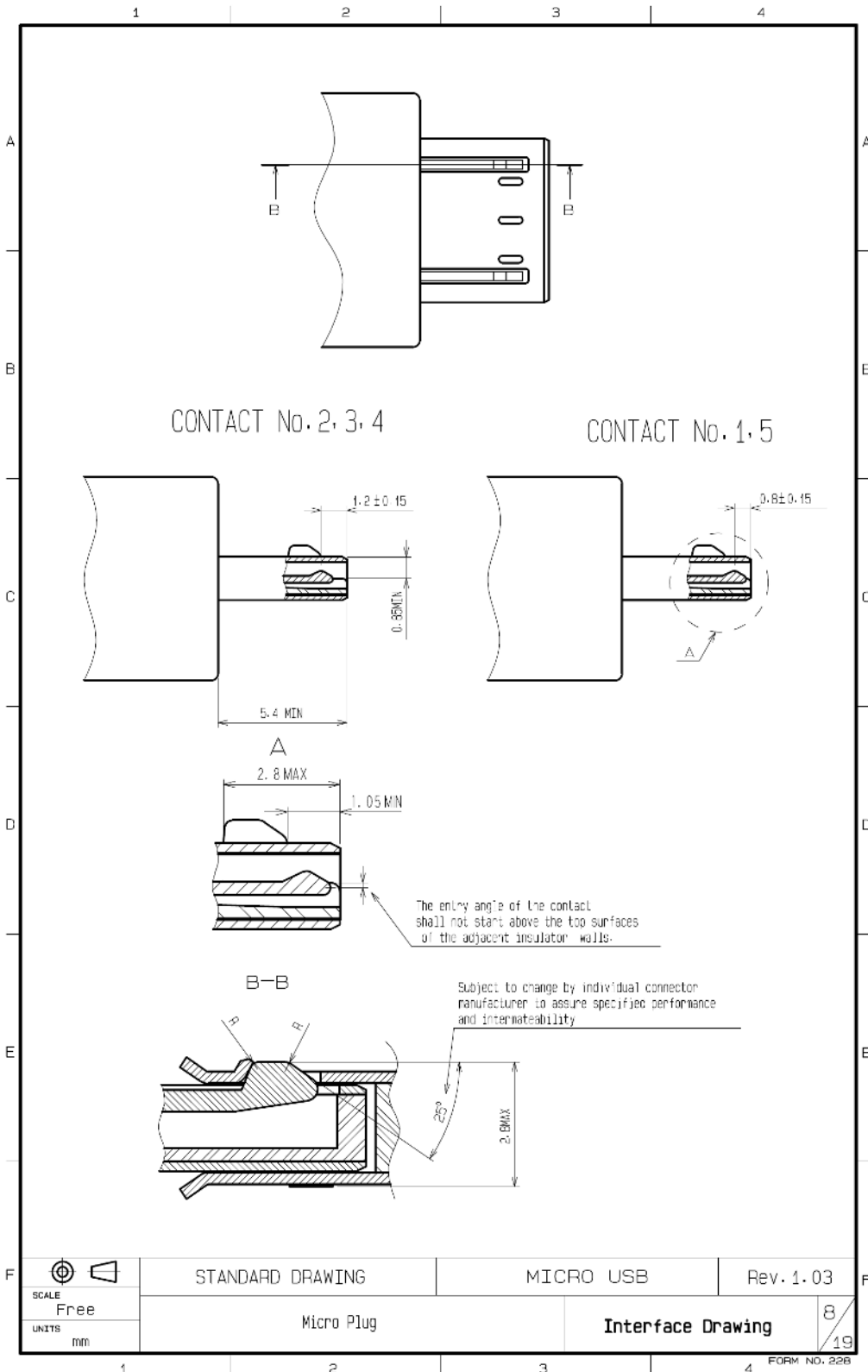

Figure 4-8 Micro-A/B Plug Interface (Cut-section)

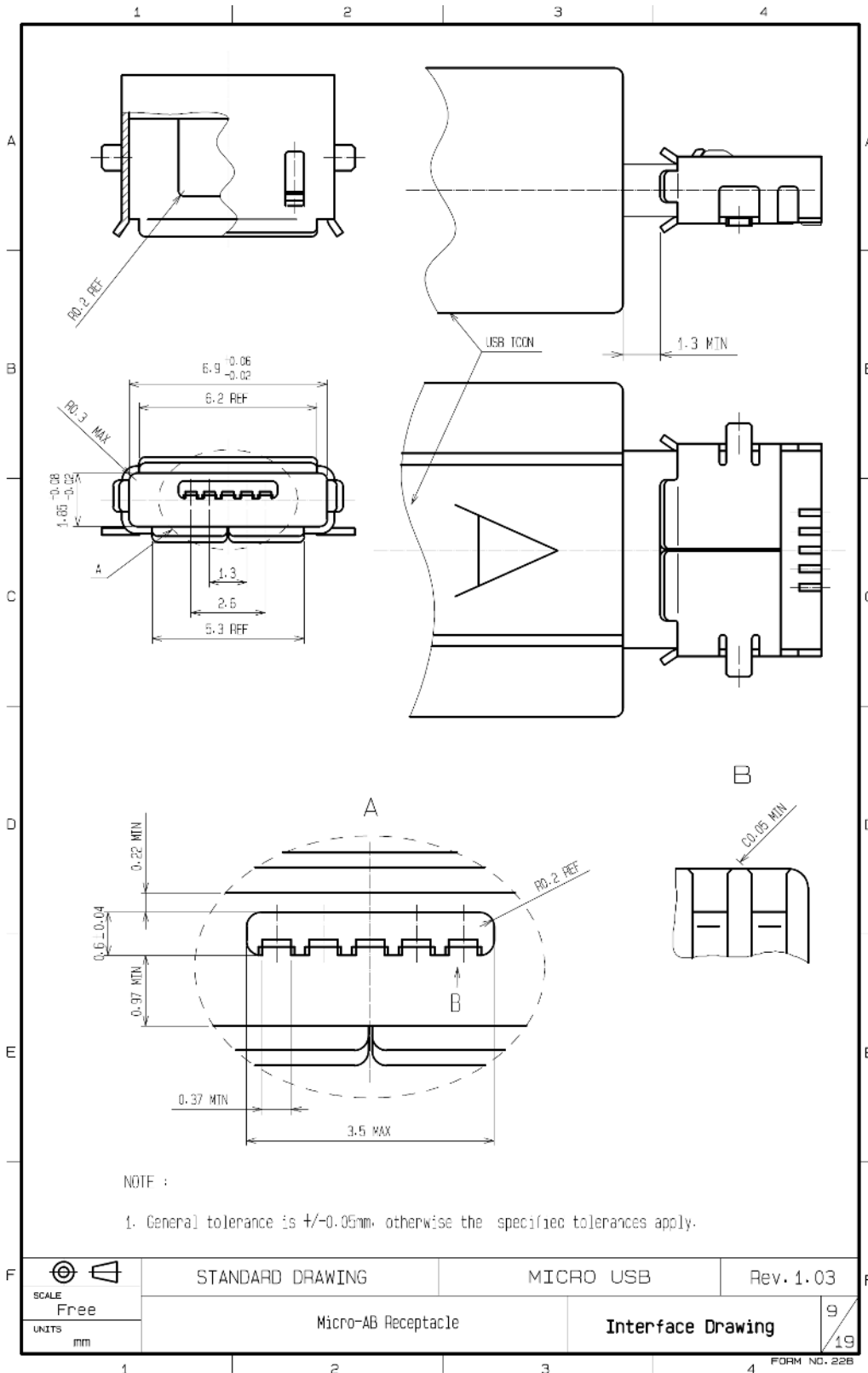

Figure 4-9 Micro-AB receptacle interface

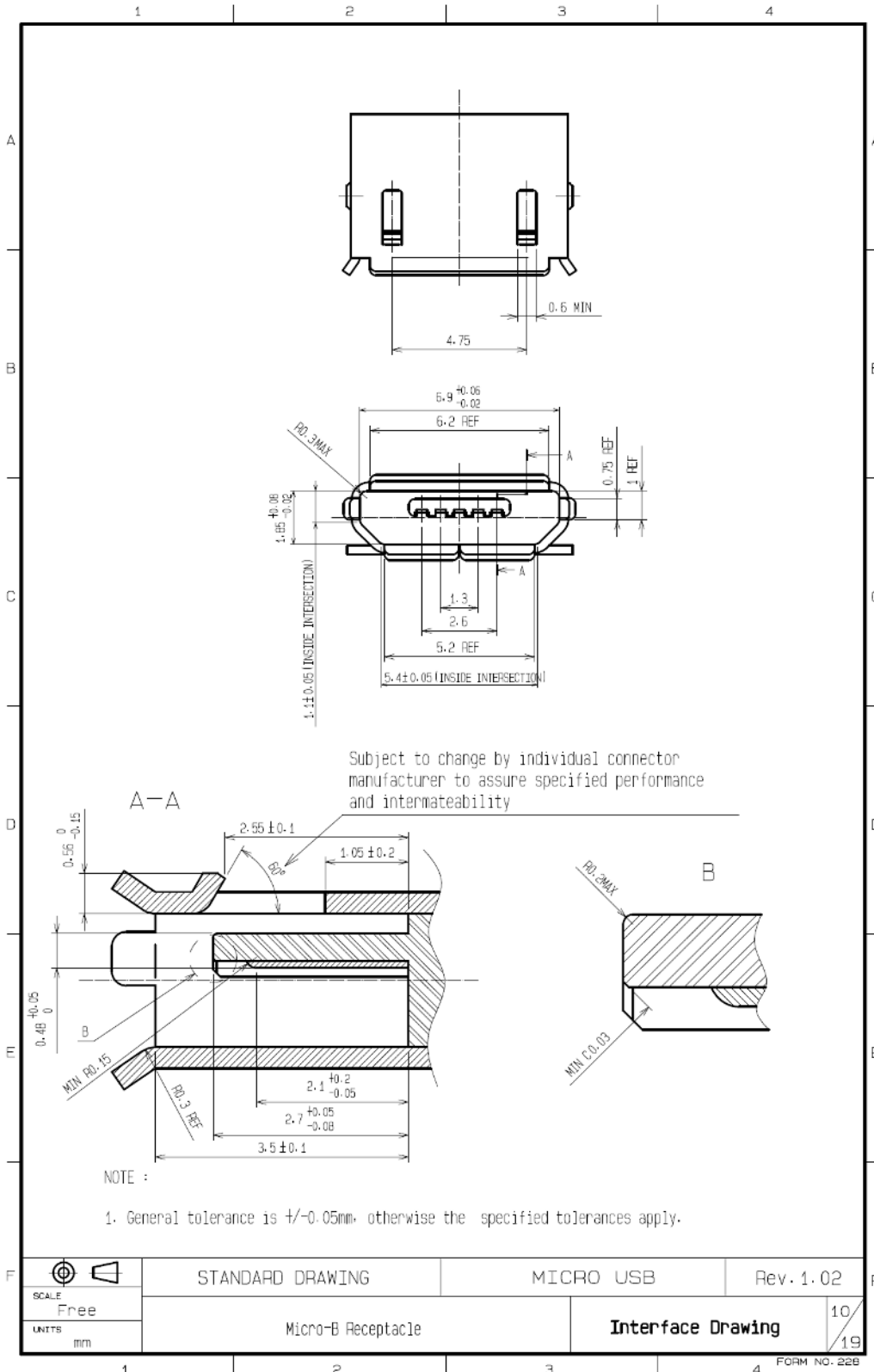

Figure 4-10 Micro-B receptacle interface

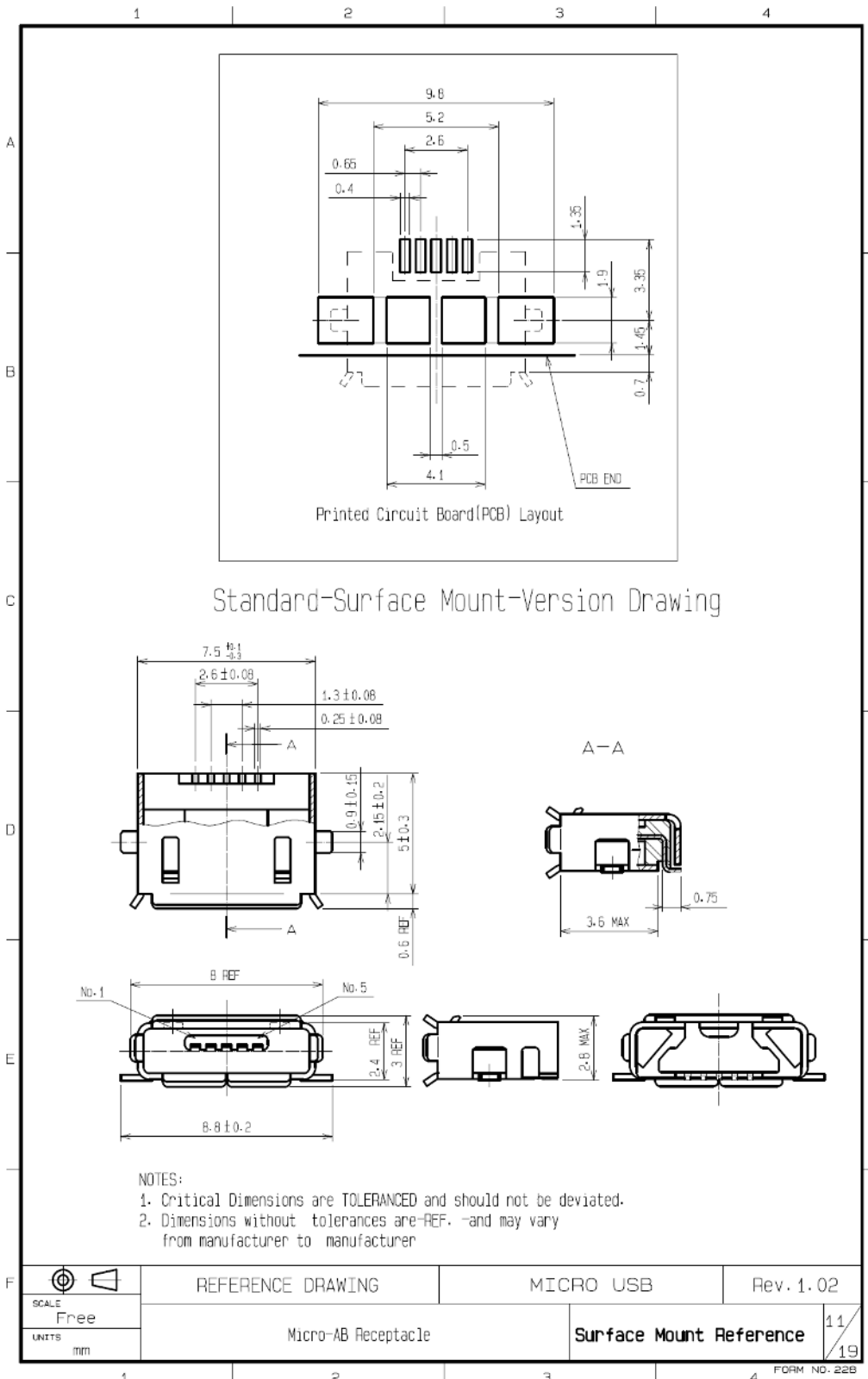

Figure 4-11 Micro-AB Receptacle Design

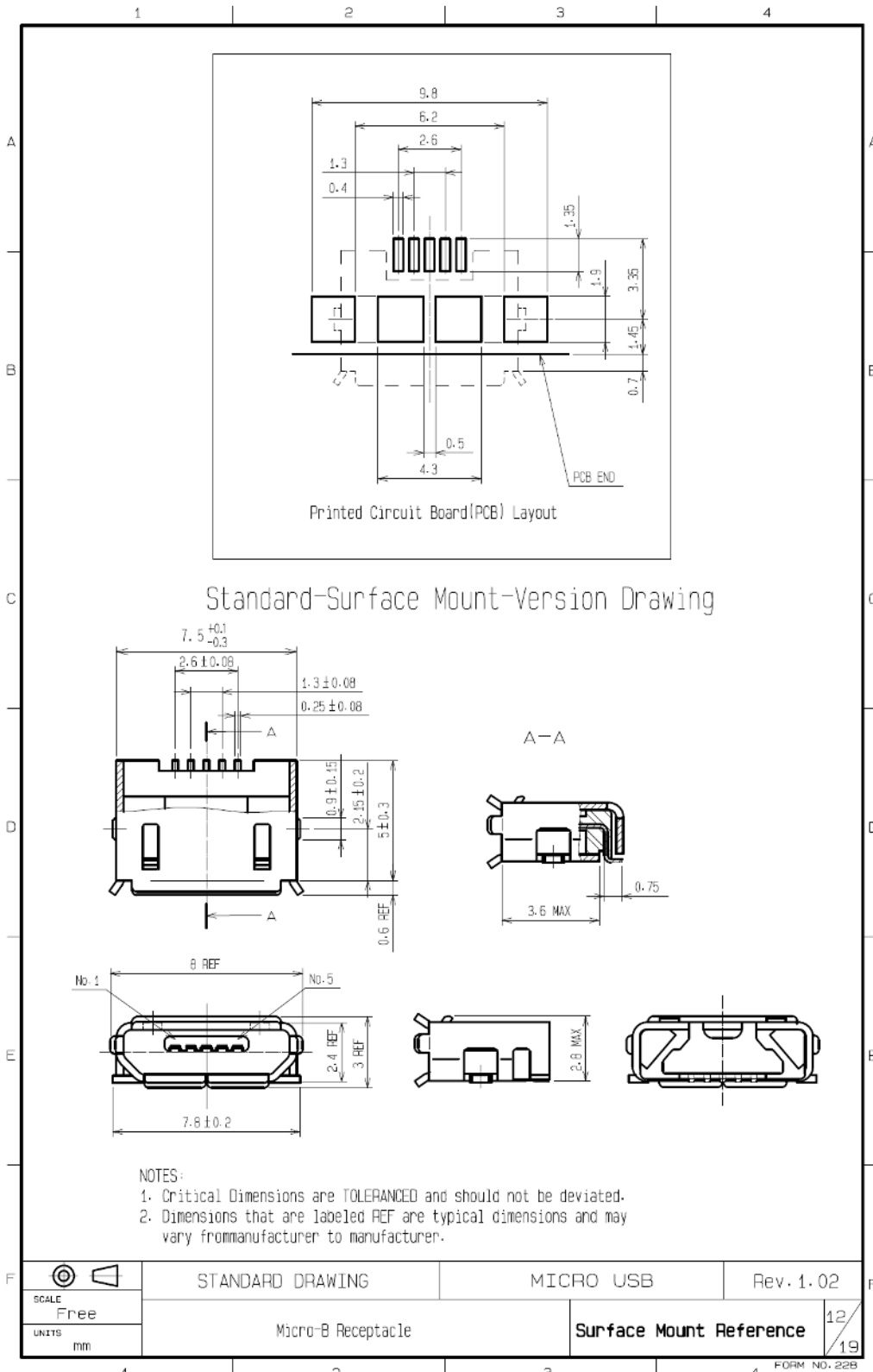

Figure 4-12 Micro-B Receptacle Design

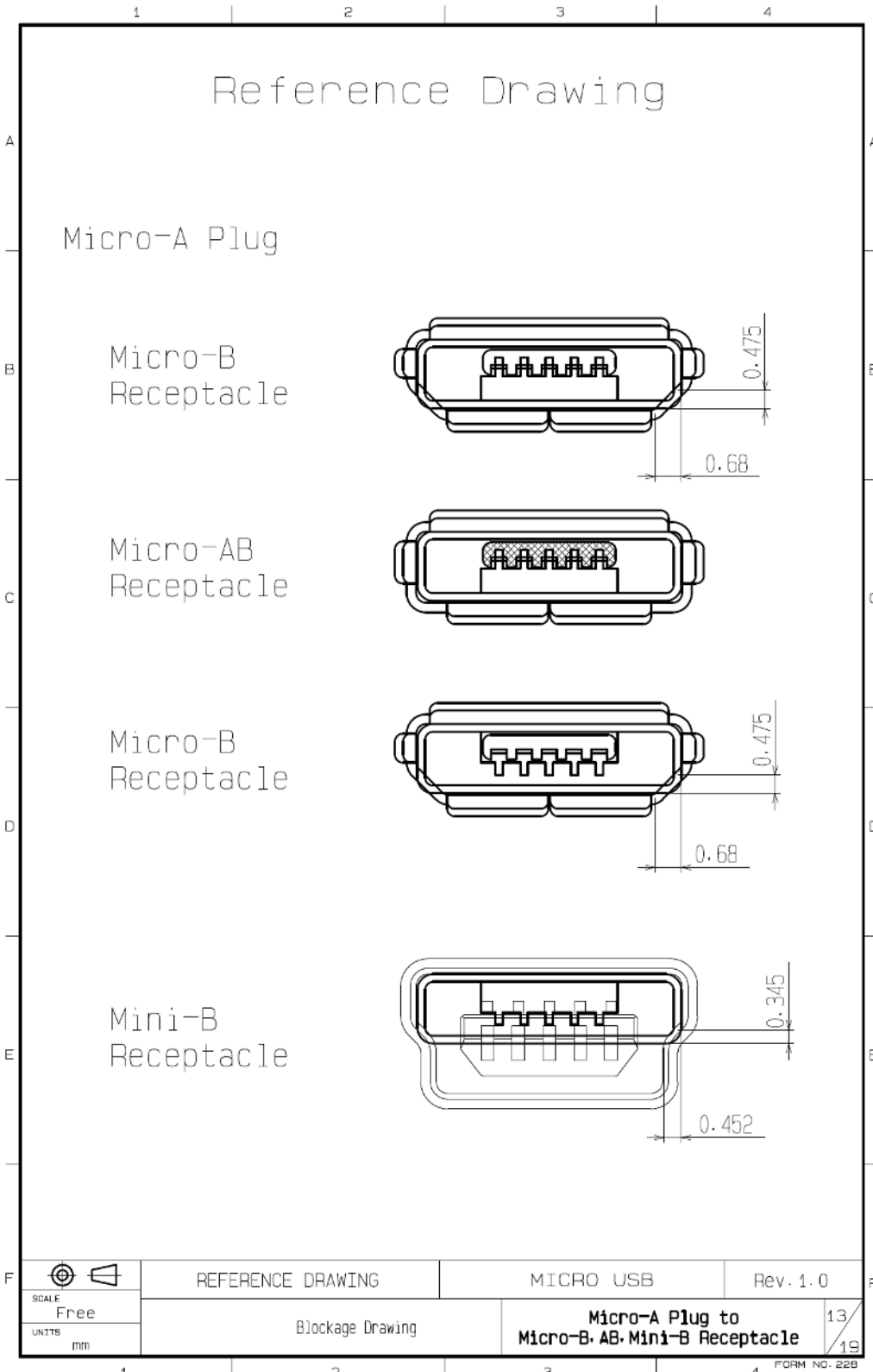

Figure 4-13 Micro-A Plug Blockage

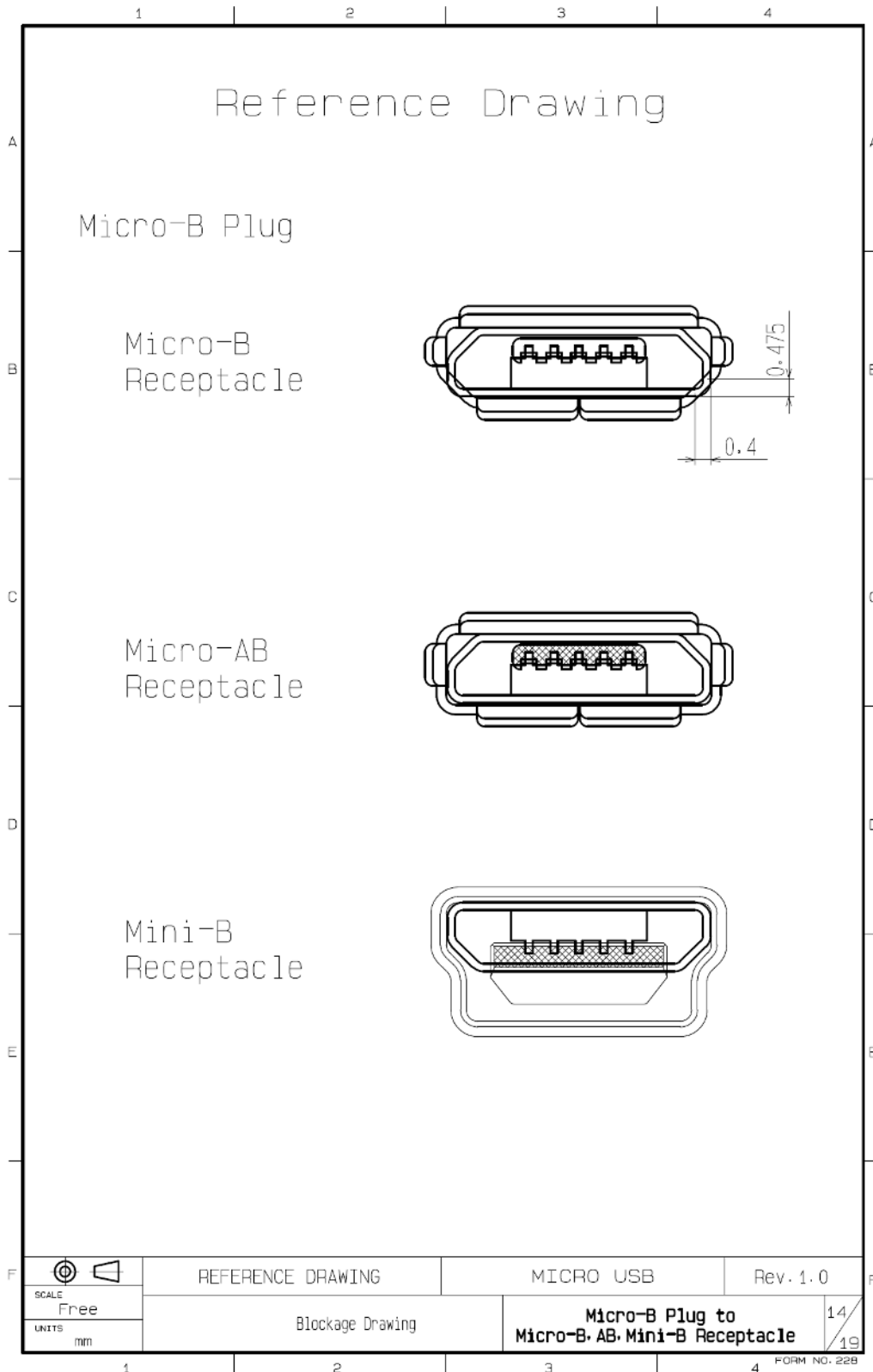

Figure 4-14 Micro-B Plug Blockage

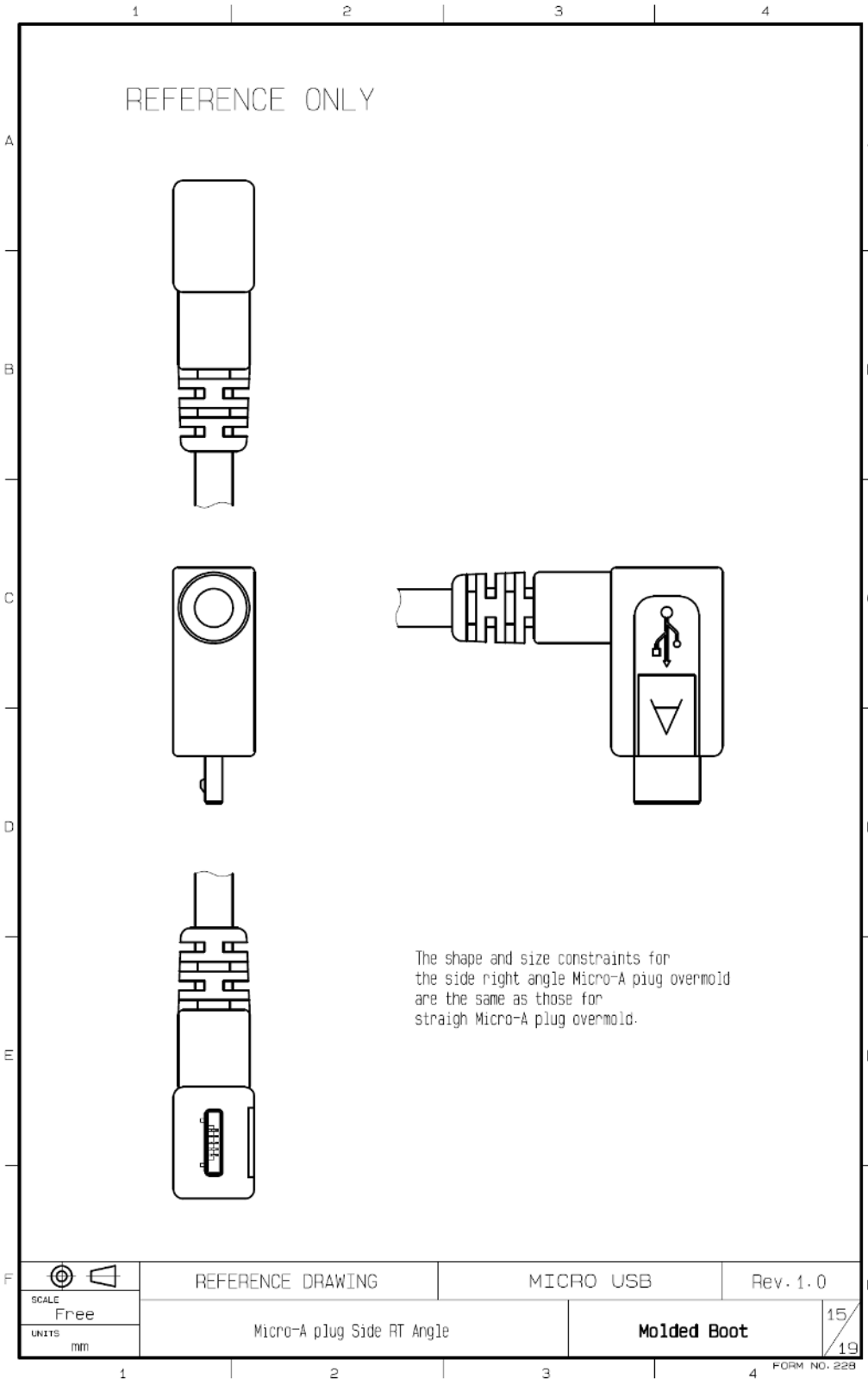

Figure 4-15 Micro-A Plug, Side Right Angle

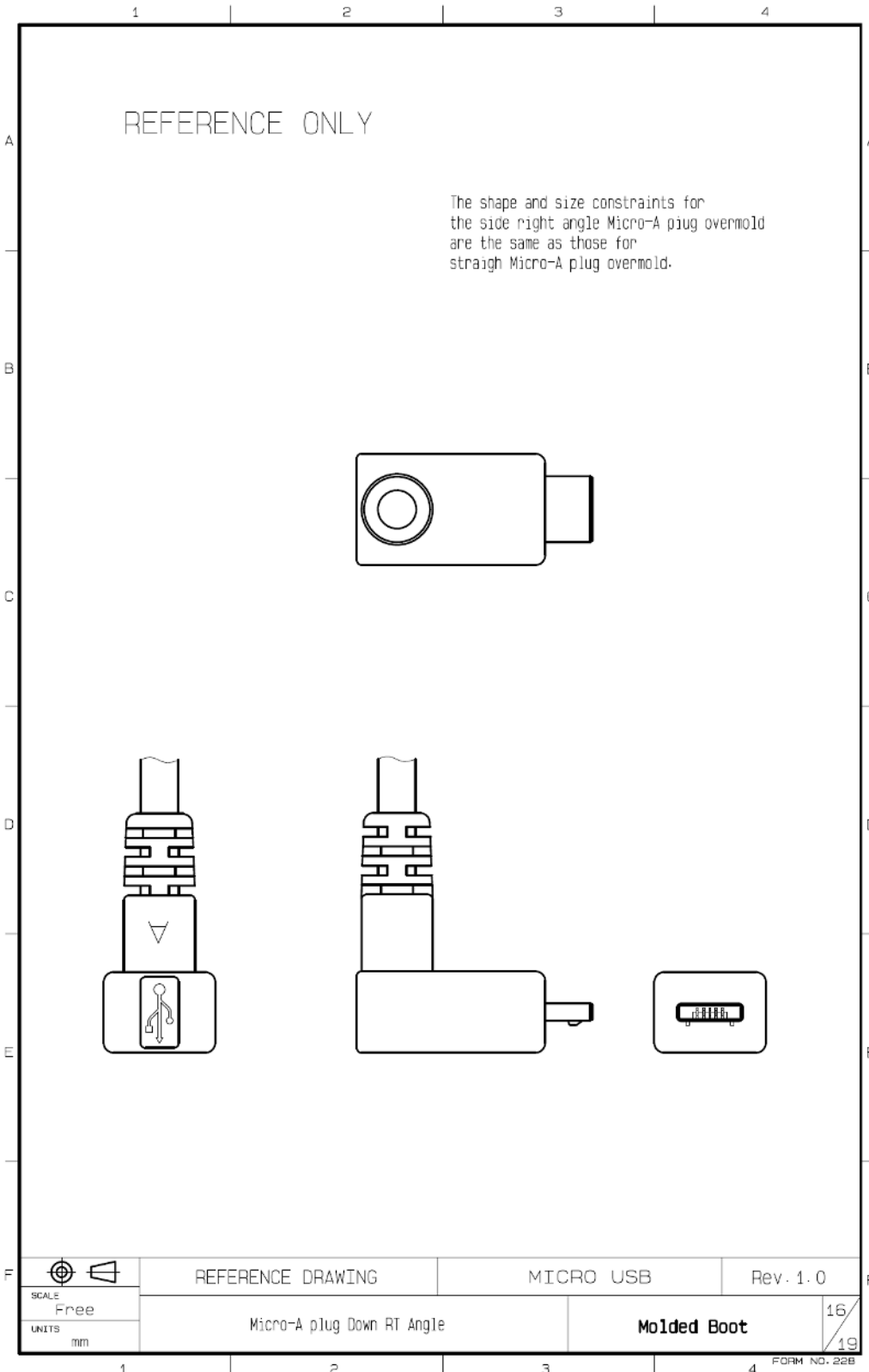

Figure 4-16 Micro-A Plug, Down Right Angle

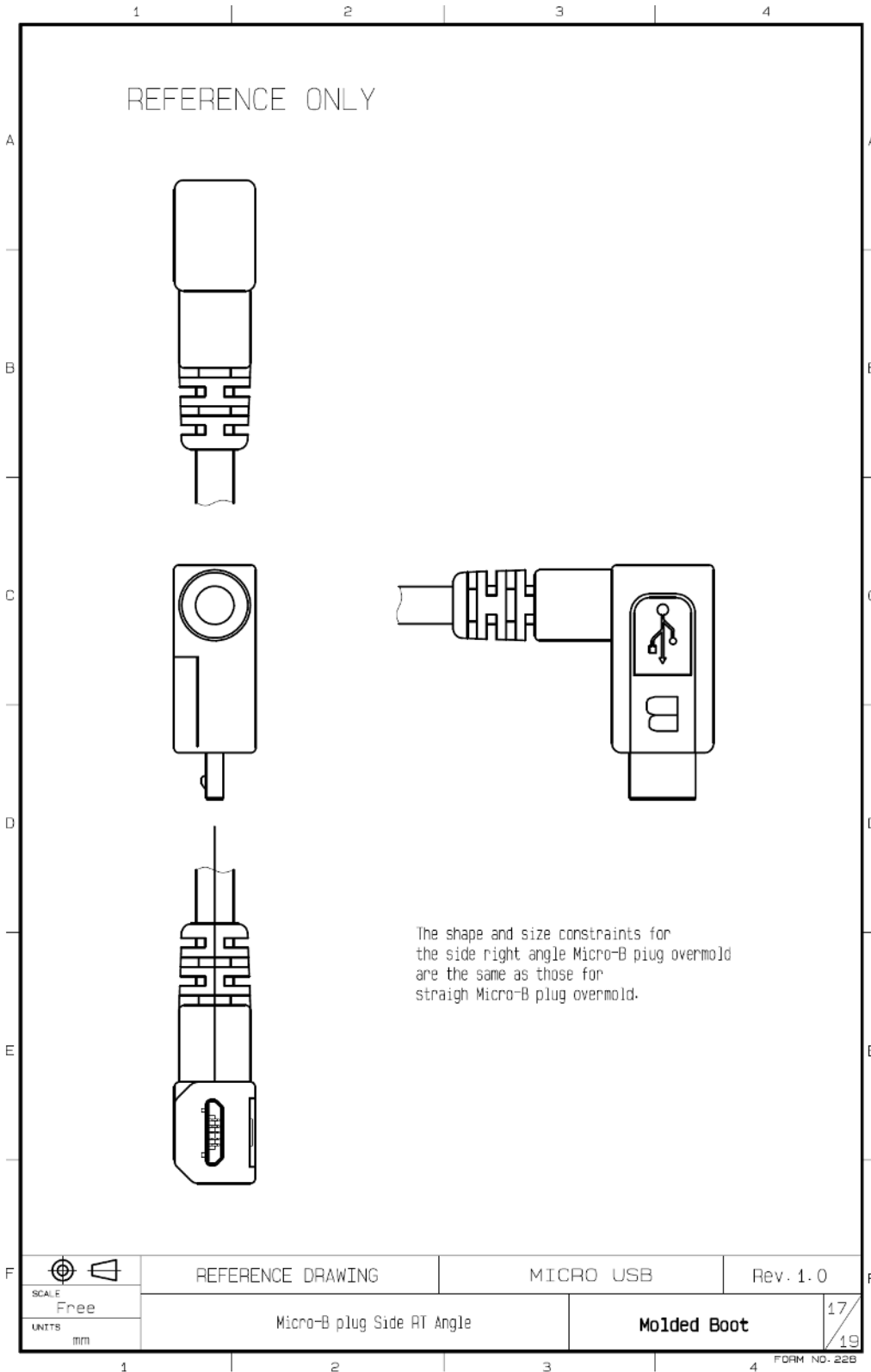

Figure 4-17 Micro-B Plug, Side Right Angle

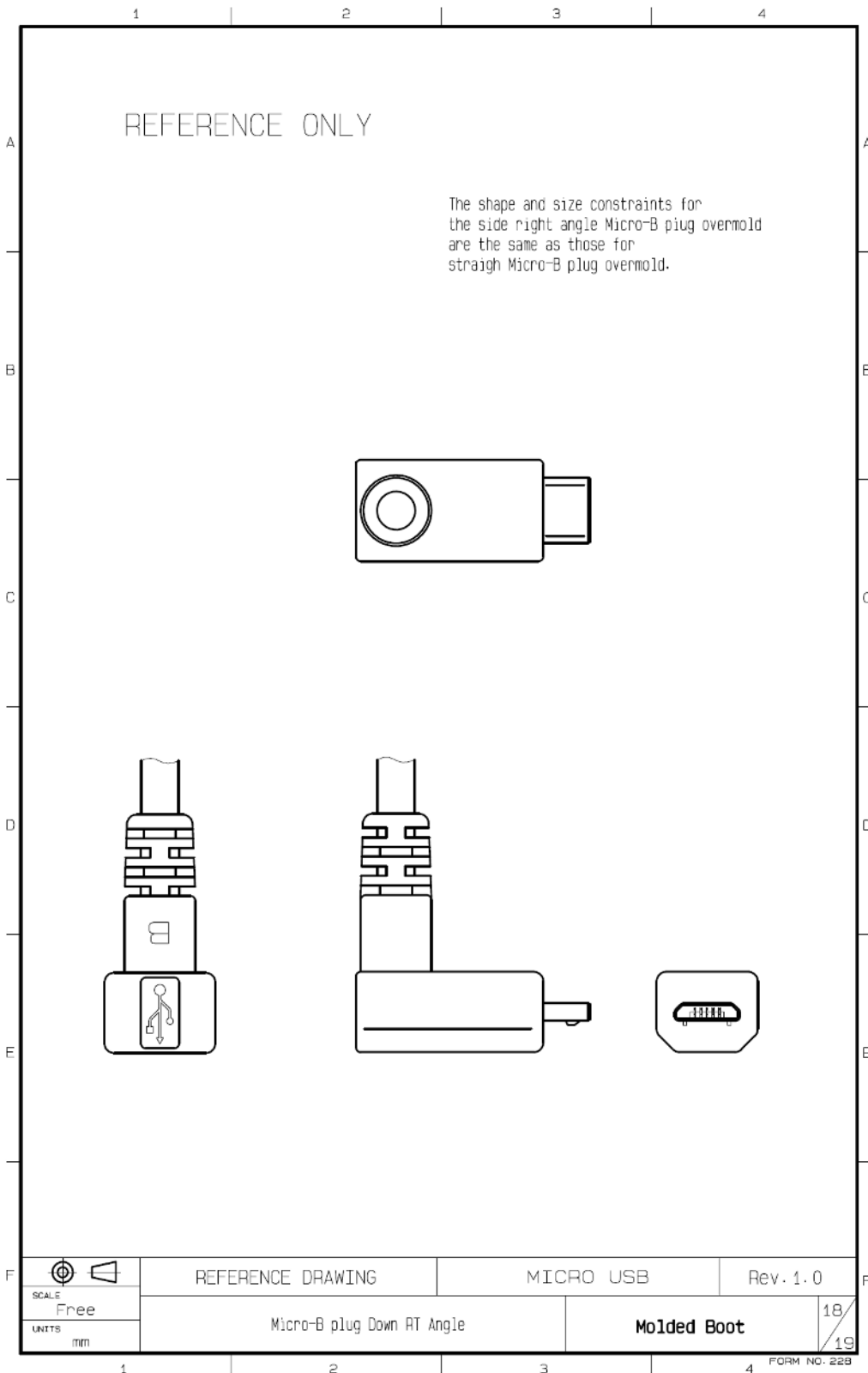

Figure 4-18 Micro-B Plug, Down Right Angle

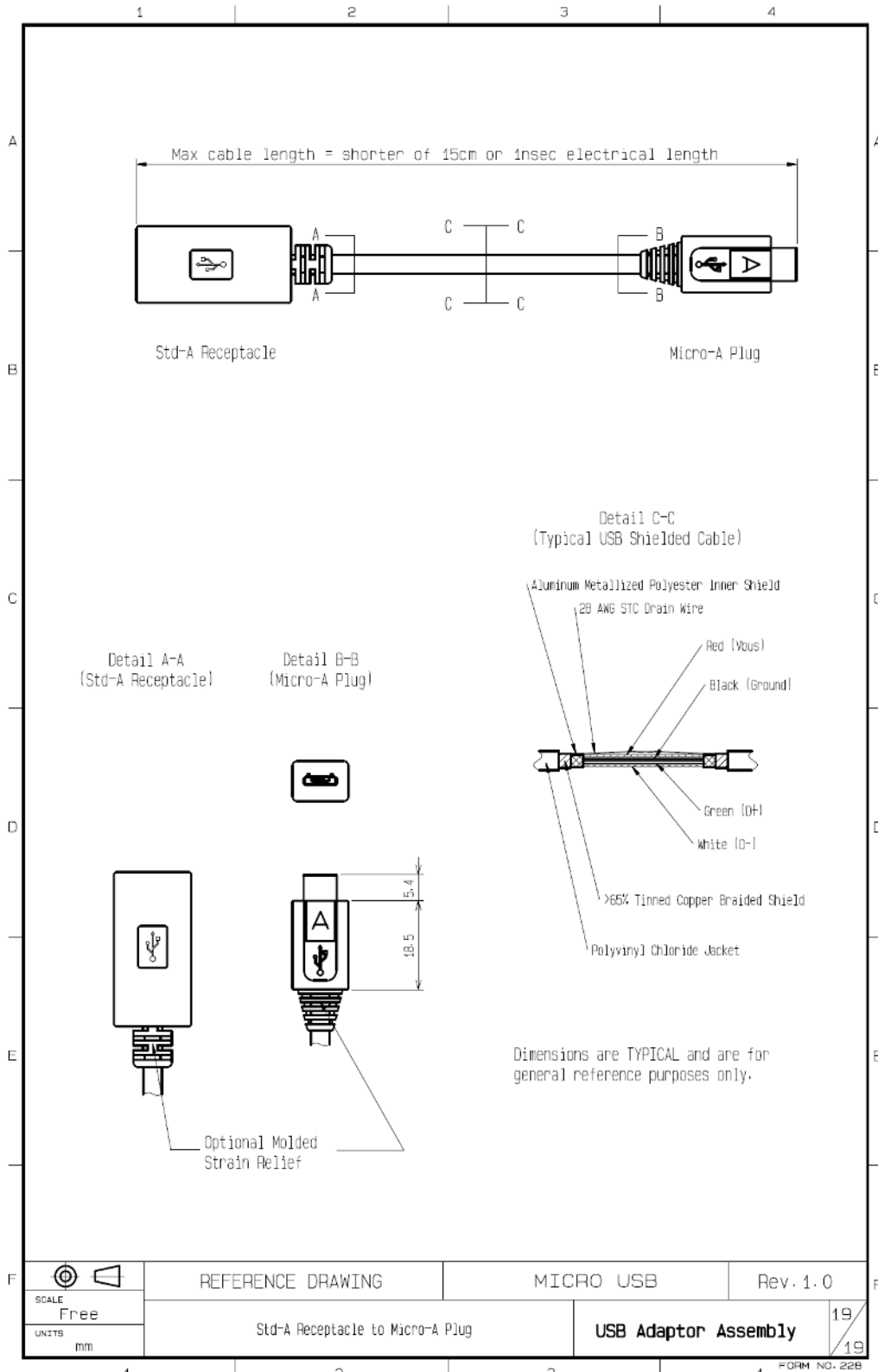

Figure 4-19 Adapter, Standard-A receptacle to Micro-A plug

5 Electrical Compliance Requirements

Electrical requirements are unchanged from the USB 2.0 specification (Chapter 6; Table 6-7) and the On-The-Go Supplement to the USB 2.0 Specification, unless otherwise specified here.

5.1 Data Rates Beyond USB 2.0 (480Mb/s -->)

This section will be amended as requirements for higher data rates (beyond the current USB 2.0 specification) become available.

5.2 Low Level Contact Resistance

30mΩ (Max) initial when measured at 20mV (Max) open circuit at 100mA. Maximum change (delta) of **+10 mΩ** after 10,000 insertion/extraction cycles at a maximum rate of 500 cycles per hour. (When manually operated, mating speed should be below 200 cycles per hour.)

5.3 Contact Current Rating

5.3.1 Signal Contacts Only (2, 3, and 4)

1A minimum when measured at an ambient temperature of 25 degrees Celsius. With power applied to the contacts, the delta temperature must not exceed +30degrees Celsius at any point in the USB connector under test.

5.3.2 With Power Applied Contacts (1 and 5)

1.8A for contacts 1 and 5 and at the same time 0.5A for contacts 2, 3 & 4, minimum when measured at an ambient temperature of 25 degrees Celsius. With power applied to the contacts, the delta temperature must not exceed +30degrees Celsius at any point in the USB connector under test.

6 Mechanical Compliance Requirements

The following requirements will take precedence over the requirements set forth in the USB 2.0 specification (Chapter 6; Table 6-8) and the On-The-Go Supplement to the USB 2.0 Specification.

6.1 Operating Temperature Range

6.1.1 Option I

-30°C to +80°C

Option II

-30°C to +85°C (and above)

6.2 Insertion Force

Recommendations:

- It is recommend to use a non-silicon based lubricant on the latching mechanism to reduce wear. If used the lubricant may not affect any other characteristic of the system.
- 35 Newton's maximum at a maximum rate of 12.5 mm(0.492") per minute.

6.3 Extraction Force

- 8N (MIN) after 10000 insertion/extraction cycles (at a maximum rate of 12.5mm (0.492") per minute).
- No burrs or sharp edges are allowed on top of locking latches (hook surfaces which will rub against receptacle shield).
- It is recommend to use a non-silicon based lubricant on the latching mechanism to reduce wear. If used the lubricant may not affect any other characteristic of the system.

6.4 Plating

Recommendations:

- Contact plating should be done after stamping and forming
- Burrs should not be present on contact areas
- Contact area as smooth as possible before plating
- Use a sealing treatment to control plating porosity (contact area)

6.4.1 Option I

6.4.1.1 Receptacle

Contact area: (Min) 0.05 μm Au + (Min) 0.75 μm Ni-Pd on top of (Min) 2.0 μm Ni

Contact tail: (Min) 0.05 μm Au on top of (Min) 2.0 μm Ni

6.4.1.2 Plug

Contact area: (Min) 0.05 μm Au + (Min) 0.75 μm Ni-Pd on top of (Min) 2.0 μm Ni

6.4.2 Option II

6.4.2.1 Receptacle

Contact area: (Min) 0.75 μm Au on top of (Min) 2.0 μm Ni

Contact tail: (Min) 0.05 μm Au on top of (Min) 2.0 μm Ni

6.4.2.2 Plug

Contact area: (Min) 0.75 μm Au on top of (Min) 2.0 μm Ni

6.5 Solderability

Solder shall cover a minimum of 95% of the surface being immersed, when soldered at temperature 255°C \pm 5°C for in immersion duration 5S. (component is to be lead-free component) Using Type R flux.

6.6 Peel Strength (Reference Only)

Minimum 150N when soldered connector is pulled up from PCB in the vertical direction.

6.7 Wrenching Strength (Reference Only)

Perpendicular Force Test : This test shall be performed using virgin parts. Perpendicular forces (F_p) are applied to a plug when inserted at a distance (L) of 15mm from the edge of the receptacle. Testing conditions & method should be agreed with all parties. These forces are to four direction (left, right, up, down). Compliant connectors will meet the following force thresholds with the following results :

- No plug or receptacle damage: 0 - 25N
- The plug can be damaged, but in such a way that the receptacle does not sustain damage: 25 - 50N

6.8 Lead Co-Planarity

Co-planarity of all SMT leads shall be within 0.08mm range.

6.9 RoHS Compliance

Component is to be RoHS compliant. Lead Free plug and receptacle materials must conform to Directive 2002/95/EC of January 27,2003 on Restriction of Hazardous Substances (RoHS).

6.10 Shell & Latch Materials

Shell and latch materials for both plug and receptacle shall be stainless steel or mechanically equivalent material.

Note:All Engineering Change Notice's (ECN) and Errata documents as of September 01, 2012 that pertain to this core specification follow the last page of the specification starting on page 37.

USB ENGINEERING CHANGE NOTICE

Title: Clarification on the Chamfer on USB 2.0 Micro Connectors

Applies to: MicroUSB Specification to the USB 2.0 Specification,
Revision 1.01

Summary of ECN

Modify the USB2.0 micro receptacle definition so that the external chamfer metals are optional as they are in the USB3.0 micro specification.

Reasons for ECN

A number of the portable device manufacturers are asking for Micro-series receptacles that have the lead-in chamfer removed. This is primarily an Industrial Design concern as it improves the aesthetics of products.

Impact on Existing Peripherals and Systems:

No significant impact on the existing parts as they still conform to the specification. Even if the chamfer metals are removed, the guiding function and the insertion force stay the same because the inner side of the shell edge has taper.

Hardware Implications:

None.

Software Implications:

None.

Compliance Testing Implications:

The change does not affect the mechanical and electrical performance specified in the current USB2.0 compliance specification. The test items in the specification were all passed.

Specification Changes

Universal Serial Bus Micro-USB Cables and Connectors specification Revision 1.01

The ECR proposes to add a note “Chamfer metals are optional with no sharp edges.” to the Figure 4-9 Micro-AB receptacle interface on the page 24 and to the Figure 4-10 Micro-B receptacle interface on the page 25 as shown in the following pages.

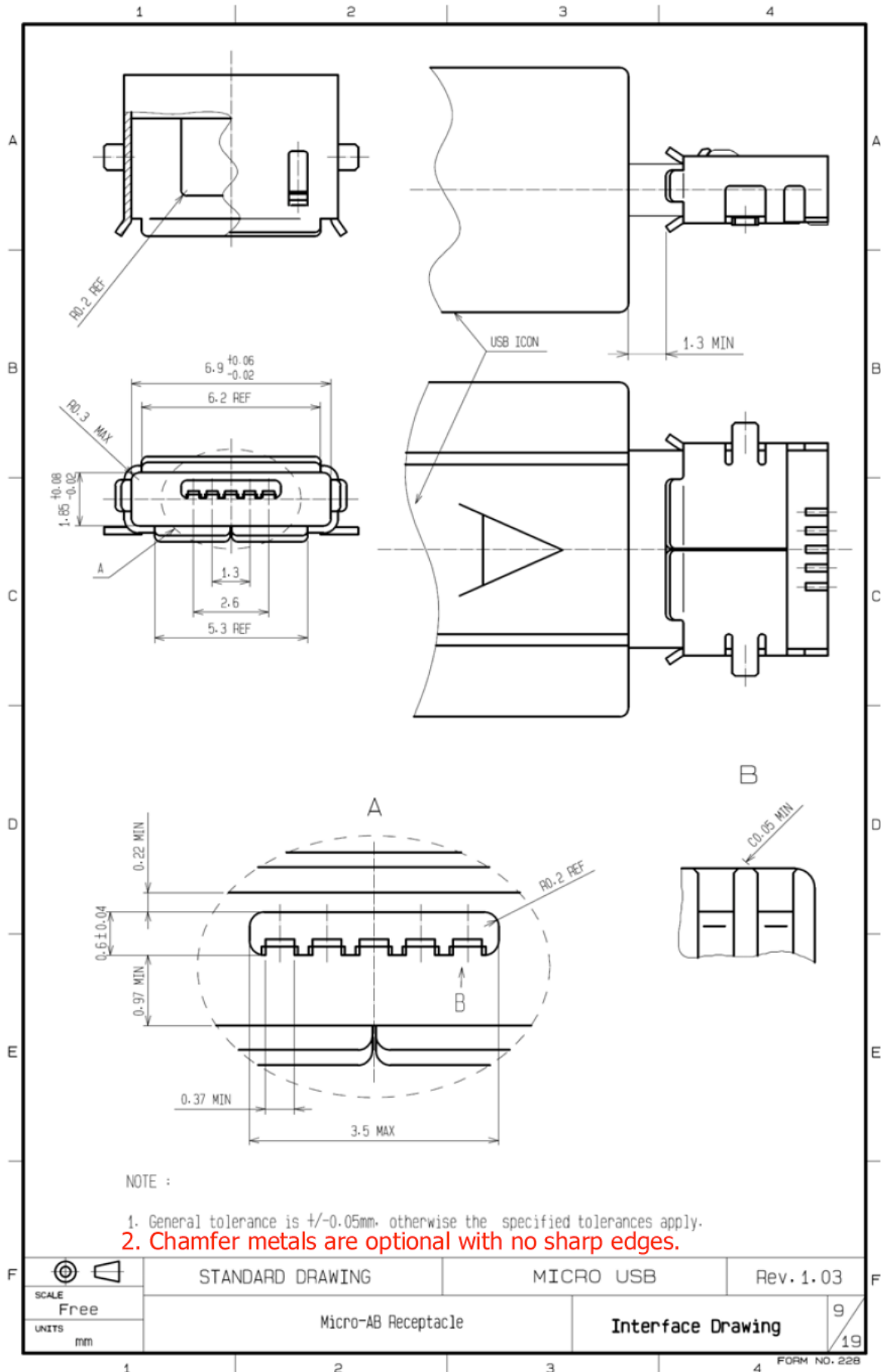

Figure 4-9 Micro-AB receptacle interface

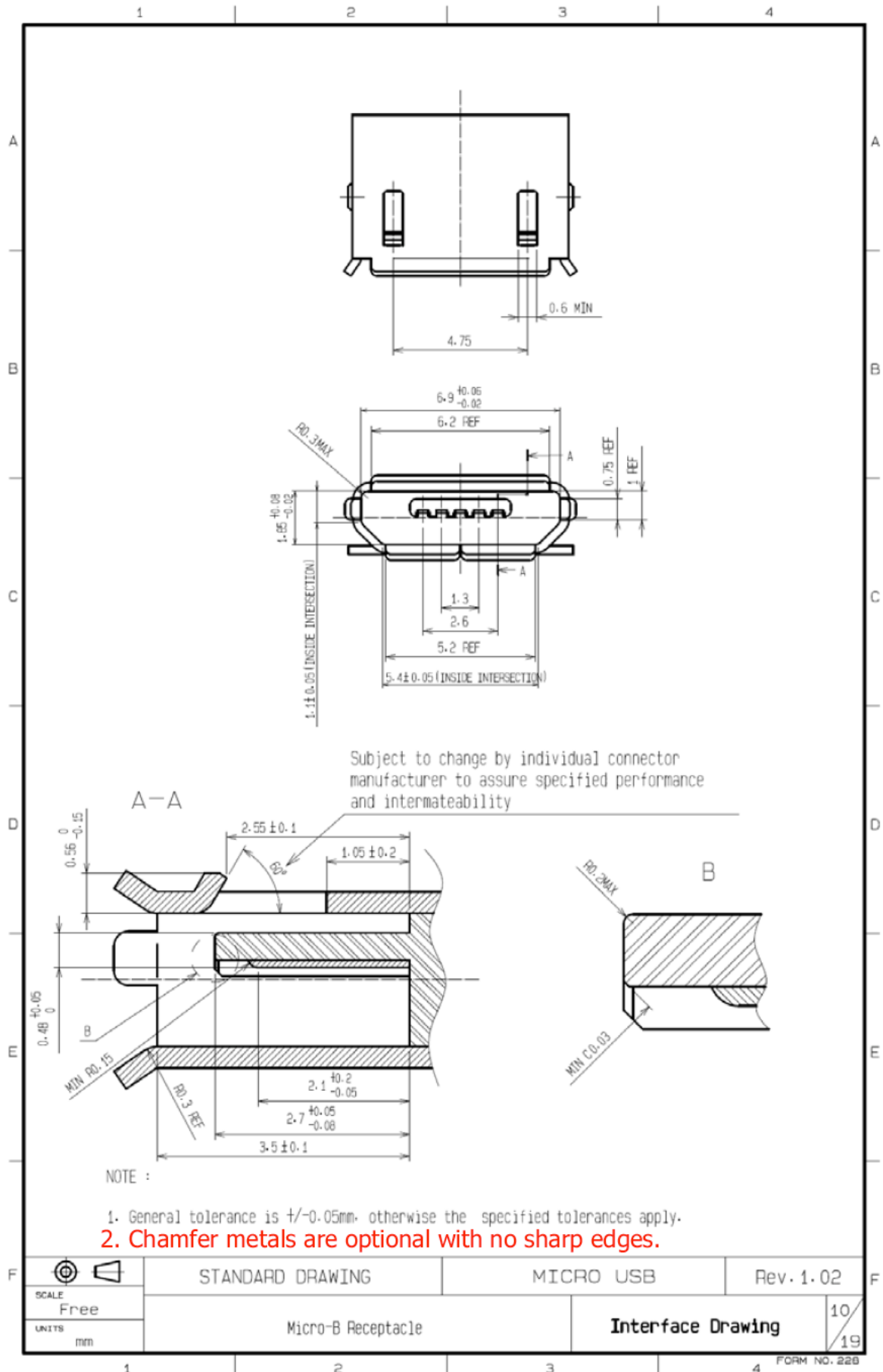

Figure 4-10 Micro-B receptacle interface

USB ENGINEERING CHANGE NOTICE

Title: MicroUSB Micro-B ID Pin Resistance and Tolerance stack-up between D+ and D-

Applies to: MicroUSB Specification to the USB 2.0 Specification, Revision 1.01

Summary of ECN

Increase the minimum resistance to ground of the MicroB plug ID pin.

Reasons for ECN

The resistance change to the ID pin of the MicroUSB B plug is required for the identification of the battery charger. This change will give the battery charger the required margin and eliminate overlap in the battery charger specification. The tolerance stack-up between D+ and D- is required to ensure charging ID is properly sequenced.

Impact on Existing Peripherals and Systems:

This ECR increases the resistance to 1Mohm. Any cables that have a micro b plug with an ID resistance between 1Kohm and 1Mohm will be affected.

Hardware Implications:

Cables and plugs that support the “floating” state according to the Micro-USB spec will not have to change, since they don’t have an actual resistor to ground on the ID pin that needs to be changed. The ID pin is simply floating, so this change (100 Kohm to 1 M Ω) will have no implications there.

Software Implications:

This will have no implications on software.

Compliance Testing Implications:

The testing threshold for the Rb_PLUG_ID parameter in the Micro-USB spec needs to be changed to support the 1 M Ω min instead of the 100 Kohm min.

Specification Changes

In Section 4.2 after Table 4-2 change:

The ID pin on a Micro-A plug shall be connected to the GND pin. The ID pin on a Micro-B plug is not connected or is connected to ground by a resistance of greater than Rb_PLUG_ID (100k Ω MIN).

To:

The ID pin on a Micro-A plug shall be connected to the GND pin. The ID pin on a Micro-B plug is not connected or is connected to ground by a resistance of greater than Rb_PLUG_ID (1M Ω MIN).

Additional Changes to be made to the specification:

Add a note to Figure 4-8 of the MicroUSB specification that the tolerance stack-up between D+ and D- cannot exceed a total of ± 0.075 mm between the two pins.

After Table 4-2 reference Figure 4-8 and note that the point of contact for D+ and D- must mate within 0.15 mm maximum.

USB ENGINEERING CHANGE NOTICE

Title: Quad type cable additional for Micro USB
Applies to: Universal Serial Bus Micro-USB Cables and Connectors Specification, Revision 1.01

Summary of ECN

The current Micro-USB specification in Section 4.5.1 specifies “The cables allowed by the Micro-USB specification are shown in Figure 4-1, Figure 4-2, Figure 4-3. and meet all other requirements of a USB cable” that a typical USB cable construction consist of non-twisted power pair, twisted signal pair, drain wire, aluminum shield, braiding and cable jacket. This ECN allows a Micro-USB cable to be constructed with the data and power lines twisted together and to not have a drain wire as is currently required in the Micro-USB specification Revision 1.01. Such a Micro-USB cable is referred to as a Quad Type Micro-USB cable.

Reasons for ECN

The benefits of this ECN are that a Quad Type Micro-USB cable can be produced that has a smaller diameter, is more flexible and has good bending performance. In addition, the cost of these cables will be less than standard Micro-USB cables, due the fact that these cables require reduced amount of material, less material for packaging due to smaller bundle shape, and reduced transportation costs.

Impact on Existing Peripherals and Systems:

This ECN meets all the electrical requirements for Micro-USB cables. So there is no impact on the existing peripherals and systems.

(Ref. XV-4687C ECN Proposal for Micro USB (080815).pdf)

(Ref. XV-4687C_Supplement Quad cable R1 (091202).pdf)

Hardware Implications:

There is no implication and impact.

Software Implications:

There is no implication and impact.

Compliance Testing Implications:

The Cable Assemblies Test must be updated to state that a Micro-USB cable that has data and power lines that are twisted together without a drain wire is an acceptable Micro-USB cable when visually verifying the cable construction.

Specification Changes

Universal Serial Bus Micro-USB Cables and Connectors specification Revision 1.01

From: Section 4.5.1 Cables

The cables allowed by the Micro-USB specification are shown in Figure 4-1, Figure 4-2, and Figure 4-3. Cables must have a propagation delay of 10 ns or less, have a physical length of no more than 2.0 meters, and meet all other requirements of a USB cable.

To:

Section 4.5.1 Cables

The cables allowed by the Micro-USB specification are shown in Figure 4-1, Figure 4-2, and Figure 4-3. Cables must have a propagation delay of 10 ns or less, have a physical length of no more than 2.0 meters, and meet all other requirements of a USB cable. **However, Micro-USB cables may be manufactured that have the data and power lines twisted together and without a drain wire. Such a Micro-USB cable is referred to as a Quad Type Micro-USB cable.**

Note that in Fig4-1, Fig4-2 and Fig4-3 “Micro-USB cables can have their data and power lines twisted together without a drain wire”.

**Universal Serial Bus Cables and Connectors Class Document Revision 2.0
Section 4.10.1.1.2 Cable Assemblies**

4.10.1.1.2 Cable Assemblies

The cable construction for standard detachable USB cable assemblies is to be visually verified. Cable construction must contain a braided outer shield and a metallic inner shield. A drain wire of 28 AWG or braid shield must be in contact with both shields. Cables must contain two data-lines of 28 AWG, and a power pair of 28 AWG to 20AWG. Note that a cable with the data and power lines twisted together without a drain wire is allowed for Micro-USB series. Power pairs smaller than 28 AWG are prohibited. The laboratory conducting the compliance testing is required to visually verify the construction of the cable.

Section 4.10.9 Test Group ‘8’

Test Phase	Test			Measurement To Be Performed			Common Requirements
	Title	EIA 364 Test	Severity or Condition of Test	Title	EIA 364 Test	P1	
8.5	Visual Inspection			Cable Construction			Existence of braided shield attached to shell of connector Existence of 28 gauge drain wire in contact with shield and attached to shell of connector Power lines 28 gauge minimum Data lines 28 gauge twisted

Data and power lines twisted together without a drain wire is allowed for Micro-USB series

USB ENGINEERING CHANGE NOTICE

Title: Maximum Un-mating force value definition to micro connector USB 2.0

Applies to: MicroUSB Specification to the USB 2.0 Specification,
Revision 1.01

Summary of ECN

As is common among connector specifications, currently there is no upper limit on the un-mating force of the Micro-series connectors. However, the variation in design of the passive latching feature has led to combinations with excessive extraction forces, resulting in customer dissatisfaction and the potential for device failures (broken cables or peeled off receptacles).

It is fairly critical to proper operation that the plug's latch feature be designed as described by the new reference dimensions. However, it was decided to leave these dimensions as reference only in order to avoid causing manufacturers with certified and working product to have to change their tooling even if it isn't designed exactly as described by the new reference dimensions.

Impact on Existing Peripherals and Systems:

Most of the current receptacle + plug combinations fulfill this new requirement already.

Hardware Implications:

None.

Software Implications:

None.

Compliance Testing Implications:

The un-mating force is already measured in compliance testing according to EIA 364-13 (testing standard and equipment exists).

Test should be made in test group 1, after test 1-1 and 1-2 (Max mating force and contact resistance tests) before durability cycle test; followed by other tests as is done now.

Specification Changes

Change 1.

In Section 6.3 Extraction Force (of MicroUSB Specification to the USB 2.0 Specification, Revision 1.01)

From :

- 8N (MIN) after 10000 insertion/extraction cycles (at a maximum rate of 12.5mm (0.492") per minute).
- No burrs or sharp edges are allowed on top of locking latches (hook surfaces which will rub against receptacle shield).
- It is recommend to use a non-silicon based lubricant on the latching mechanism to reduce wear. If used the lubricant may not affect any other characteristic of the system.

To :

- 8N (MIN) and 25N (MAX) before and after 10000 insertion/extraction cycles (at a maximum rate of 12.5mm (0.492") per minute).

- No burs or sharp edges are allowed on top of locking latches (hook surfaces which will rub against receptacle shield).
- It is recommended to use a non-silicon based lubricant on the latching mechanism to reduce wear. If used the lubricant may not affect any other characteristic of the system.

Change 2. (Reference)

In Figure 4-8 Micro-A/B Plug Interface (of MicroUSB Specification to the USB 2.0 Specification, Revision 1.01)

Add REF latch height 0.6mm MAX and REF latch angle 60° (same as receptacle side Ref angle)

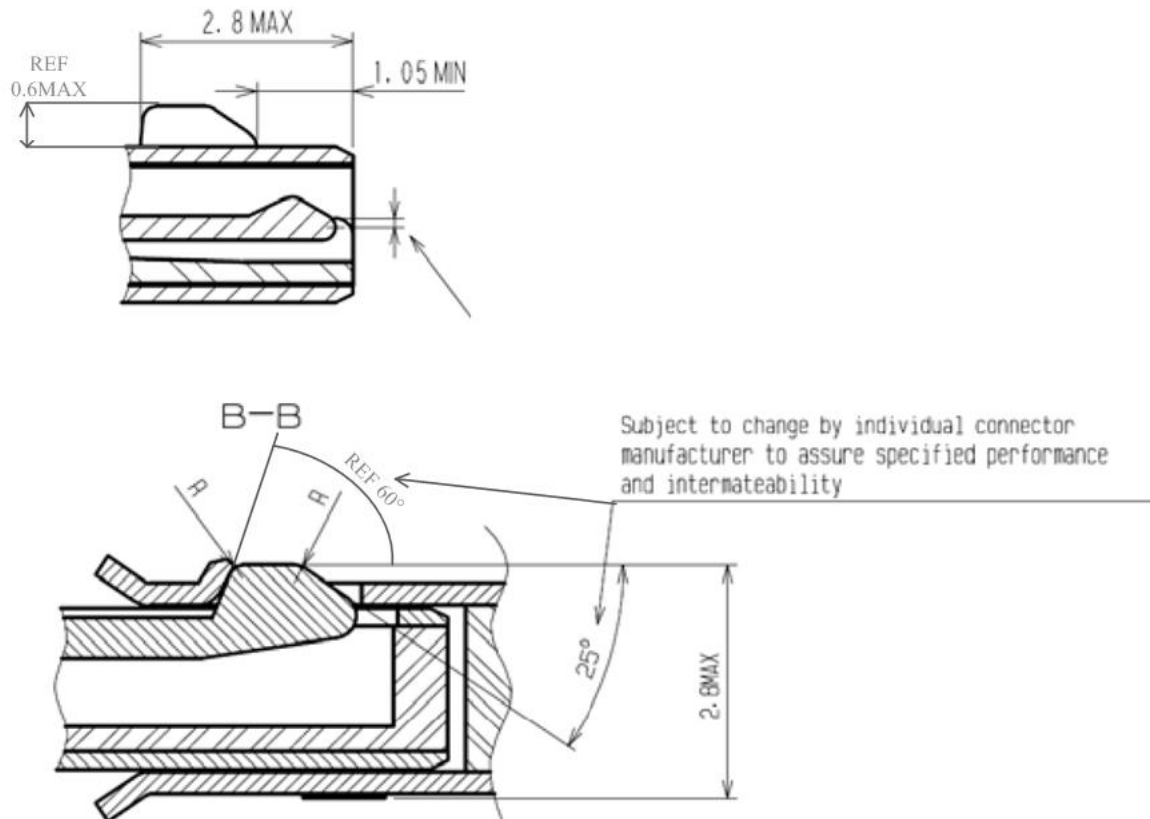

British Standards Institution (BSI)

BSI is the national body responsible for preparing British Standards and other standards-related publications, information and services.

BSI is incorporated by Royal Charter. British Standards and other standardization products are published by BSI Standards Limited.

About us

We bring together business, industry, government, consumers, innovators and others to shape their combined experience and expertise into standards-based solutions.

The knowledge embodied in our standards has been carefully assembled in a dependable format and refined through our open consultation process. Organizations of all sizes and across all sectors choose standards to help them achieve their goals.

Information on standards

We can provide you with the knowledge that your organization needs to succeed. Find out more about British Standards by visiting our website at bsigroup.com/standards or contacting our Customer Services team or Knowledge Centre.

Buying standards

You can buy and download PDF versions of BSI publications, including British and adopted European and international standards, through our website at bsigroup.com/shop, where hard copies can also be purchased.

If you need international and foreign standards from other Standards Development Organizations, hard copies can be ordered from our Customer Services team.

Subscriptions

Our range of subscription services are designed to make using standards easier for you. For further information on our subscription products go to bsigroup.com/subscriptions.

With **British Standards Online (BSOL)** you'll have instant access to over 55,000 British and adopted European and international standards from your desktop. It's available 24/7 and is refreshed daily so you'll always be up to date.

You can keep in touch with standards developments and receive substantial discounts on the purchase price of standards, both in single copy and subscription format, by becoming a **BSI Subscribing Member**.

PLUS is an updating service exclusive to BSI Subscribing Members. You will automatically receive the latest hard copy of your standards when they're revised or replaced.

To find out more about becoming a BSI Subscribing Member and the benefits of membership, please visit bsigroup.com/shop.

With a **Multi-User Network Licence (MUNL)** you are able to host standards publications on your intranet. Licences can cover as few or as many users as you wish. With updates supplied as soon as they're available, you can be sure your documentation is current. For further information, email bsmusales@bsigroup.com.

BSI Group Headquarters

389 Chiswick High Road London W4 4AL UK

Revisions

Our British Standards and other publications are updated by amendment or revision.

We continually improve the quality of our products and services to benefit your business. If you find an inaccuracy or ambiguity within a British Standard or other BSI publication please inform the Knowledge Centre.

Copyright

All the data, software and documentation set out in all British Standards and other BSI publications are the property of and copyrighted by BSI, or some person or entity that owns copyright in the information used (such as the international standardization bodies) and has formally licensed such information to BSI for commercial publication and use. Except as permitted under the Copyright, Designs and Patents Act 1988 no extract may be reproduced, stored in a retrieval system or transmitted in any form or by any means – electronic, photocopying, recording or otherwise – without prior written permission from BSI. Details and advice can be obtained from the Copyright & Licensing Department.

Useful Contacts:

Customer Services

Tel: +44 845 086 9001

Email (orders): orders@bsigroup.com

Email (enquiries): cservices@bsigroup.com

Subscriptions

Tel: +44 845 086 9001

Email: subscriptions@bsigroup.com

Knowledge Centre

Tel: +44 20 8996 7004

Email: knowledgecentre@bsigroup.com

Copyright & Licensing

Tel: +44 20 8996 7070

Email: copyright@bsigroup.com



...making excellence a habit.™