

BS EN 62431:2008



BSI Standards Publication

Reflectivity of electromagnetic wave absorbers in millimetre wave frequency — Measurement methods

bsi.

...making excellence a habit.™

National foreword

This British Standard is the UK implementation of EN 62431:2008. It is identical to IEC 62431:2008. It supersedes DD IEC/PAS 62431:2005 which is withdrawn.

The UK participation in its preparation was entrusted by Technical Committee EPL/46, Cables, wires and waveguides, radio frequency connectors and accessories for communication and signalling, to Subcommittee EPL/46/2, Radio frequency connectors and waveguides.

A list of organizations represented on this committee can be obtained on request to its secretary.

This publication does not purport to include all the necessary provisions of a contract. Users are responsible for its correct application.

© BSI 2009

ISBN 978 0 580 58258 5

ICS 17.220.20; 33.120.10

Compliance with a British Standard cannot confer immunity from legal obligations.

This British Standard was published under the authority of the Standards Policy and Strategy Committee on 28 February 2009.

Amendments issued since publication

| Amd. No. | Date | Text affected |
|----------|------|---------------|
|----------|------|---------------|

English version

**Reflectivity of electromagnetic wave absorbers
in millimetre wave frequency -
Measurement methods
(IEC 62431:2008)**

Réfectivité des absorbeurs d'ondes
électromagnétiques dans la plage
des fréquences millimétriques -
Méthodes de mesure
(CEI 62431:2008)

Verfahren zur Messung
des Reflexionsvermögens von Absorbem
für elektromagnetische Wellen
im Millimeterwellen-Frequenzbereich
(IEC 62431:2008)

This European Standard was approved by CENELEC on 2008-11-01. CENELEC members are bound to comply with the CEN/CENELEC Internal Regulations which stipulate the conditions for giving this European Standard the status of a national standard without any alteration.

Up-to-date lists and bibliographical references concerning such national standards may be obtained on application to the Central Secretariat or to any CENELEC member.

This European Standard exists in three official versions (English, French, German). A version in any other language made by translation under the responsibility of a CENELEC member into its own language and notified to the Central Secretariat has the same status as the official versions.

CENELEC members are the national electrotechnical committees of Austria, Belgium, Bulgaria, Cyprus, the Czech Republic, Denmark, Estonia, Finland, France, Germany, Greece, Hungary, Iceland, Ireland, Italy, Latvia, Lithuania, Luxembourg, Malta, the Netherlands, Norway, Poland, Portugal, Romania, Slovakia, Slovenia, Spain, Sweden, Switzerland and the United Kingdom.

CENELEC

European Committee for Electrotechnical Standardization
Comité Européen de Normalisation Electrotechnique
Europäisches Komitee für Elektrotechnische Normung

Central Secretariat: rue de Stassart 35, B - 1050 Brussels

Foreword

The text of document 46F/65/CDV, future edition 1 of IEC 62431, prepared by SC 46F, R.F. and microwave passive components, of IEC TC 46, Cables, wires, waveguides, R.F. connectors, R.F. and microwave passive components and accessories, was submitted to the IEC-CENELEC Parallel Unique Acceptance Procedure and was approved by CENELEC as EN 62431 on 2008-11-01.

The following dates were fixed:

- latest date by which the EN has to be implemented
at national level by publication of an identical
national standard or by endorsement (dop) 2009-08-01
- latest date by which the national standards conflicting
with the EN have to be withdrawn (dow) 2011-11-01

Annex ZA has been added by CENELEC.

Endorsement notice

The text of the International Standard IEC 62431:2008 was approved by CENELEC as a European Standard without any modification.

Annex ZA
(normative)**Normative references to international publications
with their corresponding European publications**

The following referenced documents are indispensable for the application of this document. For dated references, only the edition cited applies. For undated references, the latest edition of the referenced document (including any amendments) applies.

NOTE When an international publication has been modified by common modifications, indicated by (mod), the relevant EN/HD applies.

| <u>Publication</u> | <u>Year</u> | <u>Title</u> | <u>EN/HD</u> | <u>Year</u> |
|--------------------|-----------------|---|------------------|--------------------|
| ISO/IEC 17025 | - ¹⁾ | General requirements for the competence of testing and calibration laboratories | EN ISO/IEC 17025 | 2005 ²⁾ |

¹⁾ Undated reference.

²⁾ Valid edition at date of issue.

CONTENTS

| | |
|---|----|
| FOREWORD | 5 |
| 1 Scope | 7 |
| 2 Normative references | 7 |
| 3 Terms, definitions and acronyms | 7 |
| 3.1 Terms and definitions | 7 |
| 3.2 Acronyms and symbols | 10 |
| 4 Specimen | 12 |
| 4.1 Specimen specification | 12 |
| 4.2 Reference metal plate | 12 |
| 4.2.1 Material and thickness | 12 |
| 4.2.2 Surface roughness | 12 |
| 4.2.3 Flatness | 12 |
| 4.2.4 Size and shape | 12 |
| 4.3 Reference specimen for calibration | 12 |
| 5 Specimen holder | 13 |
| 6 Measurement equipment | 13 |
| 6.1 Type of network analyzer | 13 |
| 6.2 Antenna | 13 |
| 6.2.1 Horn antenna | 13 |
| 6.2.2 Lens antenna | 13 |
| 6.3 Amplifier | 13 |
| 6.4 Cable | 14 |
| 7 Measurement condition | 14 |
| 7.1 Temperature and environment | 14 |
| 7.2 Warming up of measurement equipment | 14 |
| 7.3 Electromagnetic environment | 14 |
| 8 Calibration of measurement system and measurement conditions | 14 |
| 8.1 Calibration of measurement system | 14 |
| 8.2 Measurement conditions | 14 |
| 8.2.1 Dynamic range | 14 |
| 8.2.2 Setting up of the network analyzer for keeping adequate dynamic range | 14 |
| 9 Horn antenna method | 15 |
| 9.1 Measurement system | 15 |
| 9.1.1 Configuration of the measurement system | 15 |
| 9.1.2 Horn antenna | 16 |
| 9.1.3 Specimen holder | 16 |
| 9.1.4 Mounting of the specimen | 18 |
| 9.1.5 Antenna stand | 18 |
| 9.2 Measurement conditions | 18 |
| 9.2.1 Measurement environment | 18 |
| 9.2.2 Measuring distance | 18 |
| 9.2.3 Size of specimen | 18 |
| 9.3 Measurement procedures | 19 |
| 10 Dielectric lens antenna method – focused beam method | 20 |
| 10.1 Outline | 20 |

| | | |
|-----------------------|--|----|
| 10.2 | Measurement system | 20 |
| 10.2.1 | Transmitting and receiving antennas | 20 |
| 10.2.2 | Focused beam horn antenna | 21 |
| 10.2.3 | Specimen size | 22 |
| 10.2.4 | Reference metal plate size | 22 |
| 10.2.5 | Specimen holder..... | 22 |
| 10.2.6 | Method of fixing the specimen and the reference metal plate | 23 |
| 10.3 | Measurement procedures | 23 |
| 11 | Dielectric lens antenna method – parallel beam method | 25 |
| 11.1 | Principle | 25 |
| 11.1.1 | Outline | 25 |
| 11.1.2 | Parallel EM wave beam formed using a EM wave lens..... | 25 |
| 11.2 | Measurement system | 26 |
| 11.2.1 | Composition of measurement system | 26 |
| 11.2.2 | Dielectric lens antenna | 29 |
| 11.3 | Specimen | 29 |
| 11.3.1 | General | 29 |
| 11.3.2 | Reference metal plate | 29 |
| 11.3.3 | Size of specimen | 30 |
| 11.4 | Measurement procedures | 30 |
| 11.4.1 | Normal incidence..... | 30 |
| 11.4.2 | Oblique Incidence..... | 30 |
| 12 | Test report..... | 31 |
| Annex A (informative) | Reflection and scattering from metal plate – Horn antenna method | 33 |
| Annex B (informative) | Reflectivity of reference specimens using horn antenna method..... | 38 |
| Annex C (informative) | Specifications of commercially available antennas | 39 |
| Annex D (normative) | Calibration using VNA..... | 42 |
| Annex E (informative) | Dynamic range and measurement errors | 51 |
| Annex F (informative) | Enlargement of dynamic range – Calibration by isolation | 53 |
| Annex G (informative) | Relative permittivity of styrofoam and foamed polyethylene based on foam ratio | 54 |
| Annex H (informative) | Calculation of Fraunhofer region – Horn antenna method..... | 55 |
| Figure 1 | – Definition of reflectivity..... | 10 |
| Figure 2 | – Configuration of the measurement system normal incidence (S_{11})..... | 15 |
| Figure 3 | – Configuration of the measurement system oblique incidence (S_{21}) | 16 |
| Figure 4 | – Mounting method of specimen..... | 17 |
| Figure 5 | – The mechanism of adjusting azimuth and elevation | 17 |
| Figure 6 | – Measurement system for normal incidence (side view) | 20 |
| Figure 7 | – Measurement system for oblique incidence (top view)..... | 21 |
| Figure 8 | – Structure of a dielectric lens antenna | 22 |
| Figure 9 | – Structure of specimen holder..... | 23 |
| Figure 10 | – EM wave propagation using a horn antenna and a dielectric lens | 26 |
| Figure 11 | – Block diagram of the measurement system | 27 |
| Figure 12 | – A measurement system for normal incidence | 28 |

| | |
|--|----|
| Figure 13 – Measurement system for oblique incidence | 28 |
| Figure 14 – Position of a shielding plate | 29 |
| Figure 15 – Items to be mentioned in a test report | 32 |
| Figure A.1 – Reflection from the reference metal plate versus measurement distance between the antenna and the metal plate..... | 33 |
| Figure A.2 – Reflectivity of reference metal plate versus size..... | 34 |
| Figure A.3 – Reflectivity of reference metal plate at 40 GHz | 35 |
| Figure A.4 – Reflectivity of reference metal plate with cross section of 200 mm × 200 mm at 40 GHz..... | 35 |
| Figure A.5 – Analysis of reflection from a metal plate..... | 37 |
| Figure B.1 – Reflectivity of a 200 mm × 200 mm silica-glass plate in millimetre wave frequency..... | 38 |
| Figure C.1 – Representative specifications of a horn antenna..... | 39 |
| Figure C.2 – Structure of cylindrical horn antenna with dielectric lens in Table C.2, A used at 50 GHz - 75 GHz..... | 40 |
| Figure C.3 – A structure of dielectric lens and horn antenna in Table C.2, D..... | 41 |
| Figure D.1 – Measurement configuration for the case of normal incidence with a directional coupler connected directly to the horn antenna..... | 42 |
| Figure D.2 – Configuration for response calibration using a reference metal plate in the case of normal incidence | 43 |
| Figure D.3 – Configuration for response calibration using a reference metal plate in the case of oblique incidence..... | 44 |
| Figure D.4 – Configuration for response and isolation calibration in the case of normal incidence | 45 |
| Figure D.5a – Response calibration Figure D.5b – Isolation calibration..... | 45 |
| Figure D.5 – Configuration for response and isolation calibration in the case of oblique incidence | 45 |
| Figure D.6 – Configuration for S_{11} 1-port full calibration in the case of normal incidence | 47 |
| Figure D.7 – Precision antenna positioner configuration..... | 48 |
| Figure D.8 – TRL calibration procedure..... | 49 |
| Figure D.9 – Measurement and TRL calibration of transmission line | 50 |
| Figure E.1 – An example of receiving level of a reference metal plate and that without a specimen | 51 |
| Figure E.2 – Dynamic range and measurement error of reflectivity..... | 52 |
| Figure F.1 – A method to remove spurious waves..... | 53 |
| Figure H.1 – Fraunhofer region and antenna gain | 55 |
| | |
| Table 1 – Acronyms | 11 |
| Table 2 – Symbols | 11 |
| Table C.1 – Antenna gain 24 dB (example A)..... | 39 |
| Table C.2 – Some specifications of antennas with dielectric lenses | 40 |
| Table G.1 – Relative permittivity and foam ratio of styrofoam..... | 54 |
| Table G.2 – Relative permittivity and foam ratio of foamed polyethylene..... | 54 |

INTERNATIONAL ELECTROTECHNICAL COMMISSION

**REFLECTIVITY OF ELECTROMAGNETIC
WAVE ABSORBERS IN MILLIMETRE WAVE FREQUENCY –
MEASUREMENT METHODS**
FOREWORD

- 1) The International Electrotechnical Commission (IEC) is a worldwide organization for standardization comprising all national electrotechnical committees (IEC National Committees). The object of IEC is to promote international co-operation on all questions concerning standardization in the electrical and electronic fields. To this end and in addition to other activities, IEC publishes International Standards, Technical Specifications, Technical Reports, Publicly Available Specifications (PAS) and Guides (hereafter referred to as "IEC Publication(s)"). Their preparation is entrusted to technical committees; any IEC National Committee interested in the subject dealt with may participate in this preparatory work. International, governmental and non-governmental organizations liaising with the IEC also participate in this preparation. IEC collaborates closely with the International Organization for Standardization (ISO) in accordance with conditions determined by agreement between the two organizations.
- 2) The formal decisions or agreements of IEC on technical matters express, as nearly as possible, an international consensus of opinion on the relevant subjects since each technical committee has representation from all interested National Committees.
- 3) IEC Publications have the form of recommendations for international use and are accepted by IEC National Committees in that sense. While all reasonable efforts are made to ensure that the technical content IEC Publications is accurate, IEC cannot be held responsible for the way in which they are used or for any misinterpretation by any end user.
- 4) In order to promote international uniformity, IEC National Committees undertake to apply IEC Publications transparently to the maximum extent possible in their national and regional publications. Any divergence between any IEC Publication and the corresponding national or regional publication shall be clearly indicated in the latter.
- 5) IEC provides no marking procedure to indicate its approval and cannot be rendered responsible for any equipment declared to be in conformity with an IEC Publication.
- 6) All users should ensure that they have the latest edition of this publication.
- 7) No liability shall attach to IEC or its directors, employees, servants or agents including individual experts and members of its technical committees and IEC National Committees for any personal injury, property damages or other damage of any nature whatsoever, whether direct or indirect, or for costs (including legal fees) and expenses arising out of the publication, use of, or reliance upon, this IEC Publication or any other IEC Publications.
- 8) Attention is drawn to the Normative references cited in this publication. Use of the referenced publications is indispensable for the correct application of this publication.
- 9) Attention is drawn to the possibility that some of the elements of this IEC Publication may be the subject of patent rights. IEC shall not be held responsible for identifying any or all such patent rights.

International Standard IEC 62431 has been prepared by subcommittee SC46F: RF and microwave passive components, of IEC technical committee 46: Cables, wires, waveguides, R.F. connectors, R.F. and microwave passive components and accessories.

IEC 62431 replaces and cancels IEC/PAS 62431 with corrections of obvious errors as noted in 46F/29A/RVN.

The text of this standard is based on the following documents:

| | |
|------------|------------------|
| CDV | Report on voting |
| 46F/65/CDV | 46F/72/RVC |

Full information on the voting for the approval of this standard can be found in the report on voting indicated in the above table.

This publication has been drafted in accordance with the ISO/IEC Directives, Part 2.

The committee has decided that the contents of this publication will remain unchanged until the maintenance result date indicated on the IEC web site under "<http://webstore.iec.ch>" in the data related to the specific publication. At this date, the publication will be

- reconfirmed,
- withdrawn,
- replaced by a revised edition, or
- amended.

A bilingual version of this publication may be issued at a later date.

REFLECTIVITY OF ELECTROMAGNETIC WAVE ABSORBERS IN MILLIMETRE WAVE FREQUENCY – MEASUREMENT METHODS

1 Scope

This International Standard specifies the measurement methods for the reflectivity of electromagnetic wave absorbers (EMA) for the normal incident, oblique incident and each polarized wave in the millimetre-wave range. In addition, these methods are also equally effective for the reflectivity measurement of other materials:

- measurement frequency range: 30 GHz to 300 GHz;
- reflectivity: 0 dB to –50 dB;
- incident angle: 0° to 80°.

NOTE This standard is applicable not only to those EMA which are widely used as counter-measures against communication faults, radio interference etc. , but also to those used in an anechoic chamber in some cases. EMAs may be any kind of material, and may have any arbitrary shape, configuration, or layered structure as pointed out below.

Material: Conductive material, dielectric material, magnetic material.

Shape: planar-, pyramidal-, wedge-type, or other specific shapes.

Layer structure: single layer, multi layers, or graded-index material.

2 Normative references

The following referenced documents are indispensable for the application of this document. For dated references, only the edition cited applies. For undated references, the latest edition of the referenced document (including any amendments) applies.

ISO/IEC 17025, *General requirements for the competence of testing and calibration laboratories*

3 Terms, definitions and acronyms

For the purposes of this document, the following terms and definitions apply.

3.1 Terms and definitions

3.1.1

ambient level

the value of radiation power or noise which exists when no measurement is being carried out at the experiment site

3.1.2

associated equipment

an apparatus or product connected for convenience or operation of the equipment

3.1.3

beam diameter

the diameter where the electric field strength decreases by 3 dB from the centre of the focused beam

3.1.4**beam waist**

the portion at which the diameter of the focused beam becomes minimum when the electromagnetic waves radiated from a transmit antenna are converged using a dielectric lens

3.1.5**beam waist diameter**

beam diameter at the beam waist

3.1.6**bistatic measurement**

measurement where the incident and reflection angle are equal

3.1.7**dielectric lens**

electromagnetic wave lens that is composed of dielectric material

Usually, it is used by mounting in front of a pyramidal or conical horn.

3.1.8**directional gain**

ratio of the radiated power density in a particular direction to the average power density that would be radiated in all directions

3.1.9**dynamic range**

difference in decibels between the receiving level from the reference metal plate and the receiving level measured when the metal plate is removed

3.1.10**electromagnetic wave absorber**

material ingredient which absorbs the electromagnetic wave energy and dissipates it thermally

3.1.11**focal distance**

distance between the centre of the dielectric lens and the focal point

3.1.12**focal point**

centre of the beam waist when the electromagnetic waves are converged using a dielectric lens

3.1.13**focused beam**

focused electromagnetic wave converged by the dielectric lens mounted in front of the horn antenna

The focused beam diameter is a few times the wavelength or more at the beam waist, which depends on the focal distance of the lens.

3.1.14**fraunhofer region**

region where the angular radiation pattern of an aperture antenna is nearly independent of the distance

3.1.15**free-space method**

measurement method that employs a single or pair of horn antennas where the specimen and the antennas are put in free space

3.1.16**fresnel region**

region where the angular radiation pattern of an aperture antenna depends on the distance except for the region extremely near to the aperture

3.1.17**horn antenna**

aperture antenna where impedance matching is taken gradually from the waveguide aperture to free space

3.1.18**monostatic measurement**

measurement where the incident and reflected waves follow the same direction and which lie at an arbitrary angle with respect to normal to the specimen surface

3.1.19**normal incidence**

the incidence for which an electromagnetic wave strikes to the specimen surface normally

The reflectivity in normal incidence is usually measured in the configuration where the incident angle of a transmitting antenna and that of a receiving antenna are within 0° to 5° with respect to the normal direction of the specimen surface.

3.1.20**oblique incidence**

the incidence for which an electromagnetic wave strikes to the specimen surface at an oblique angle

The reflectivity in oblique incidence is usually measured with a transmitting and receiving antenna set up so that the incident and reflected angle of EM wave may be equal.

3.1.21**parallel beam**

EM wave, which has a nearly flat phase front on the surface normal to the antenna axis, and which is formed using a dielectric lens set-up in front of a horn antenna

3.1.22**reference metal plate**

metal plate with the same shape and an equal surface projected area in normal to the specimen

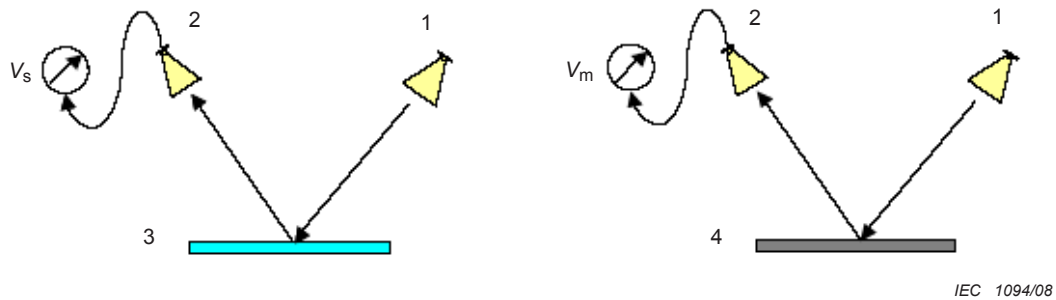
3.1.23**reflectivity**

the ratio between reflected EM wave voltage received by the receiving antenna when a specimen is irradiated by the EM wave, and the voltage of the EM wave reflected from a metal plate with equal size and with the same projection shape in normal to the specimen surface expressed in decibel by

$$\text{reflectivity} = 20 \log_{10} \left| \frac{V_S}{V_m} \right| = 20 \log_{10} |V_S| - 20 \log_{10} |V_m| \text{ [dB]} \quad (1)$$

where V_S is the reflected EM wave voltage received by the receiving antenna when a specimen is irradiated by the EM wave, and V_m is the voltage of the EM wave reflected from a

metal plate with equal size and with the same projection shape in normal to the specimen surface. See Figure 1.



Key

- 1 Tx antenna
- 2 Rx antenna
- 3 EMA
- 4 Metal plate

Figure 1 – Definition of reflectivity

3.1.24

time domain function

a function that is implemented in VNA to transform the measured frequency domain data to time evolution data using inverse Fourier transform because the VNA can measure both the amplitude and phase of EM wave

Using this function, the reflected wave only from the specimen can be extracted by applying a suitable time gating to the time evolution output signal and Fourier transform.

3.1.25

transverse electric wave

TE wave

EM wave in which the electric field is perpendicular to the plane of incidence when the EM wave is incident to the specimen surface at an oblique angle

3.1.26

transverse electromagnetic wave

TEM wave

EM wave in which both the electric and magnetic fields are perpendicular to the direction of incidence when an EM wave is incident normally to the specimen surface

3.1.27

transverse magnetic wave

TM wave

EM wave in which the magnetic field is perpendicular to the plane of incidence when the EM wave is incident to the specimen surface at an oblique angle

3.2 Acronyms and symbols

The acronyms and symbols are shown in Table 1 and Table 2.

Table 1 – Acronyms

| Acronyms | |
|----------|-------------------------------|
| CW | Continuous wave |
| EMA | Electromagnetic wave absorber |
| FFT | Fast Fourier transformation |
| IF | Intermediate frequency |
| NWA | Network analyzer |
| PTFE | Polytetrafluorethylene |
| SNA | Scalar network analyzer |
| TE | Transverse electric |
| TEM | Transverse electromagnetic |
| TM | Transverse magnetic |
| TRL | Thru-reflect-line |
| VNA | Vector network analyzer |
| VSWR | Voltage standing wave ratio |

Table 2 – Symbols

| Symbol | Meaning |
|----------|--|
| A | A half size of the aperture of an ideal absorber wall (a half side of metal plate with squared shape (Annex A)) |
| a | Longer side size at aperture of pyramidal horn antenna |
| b | Shorter side size at the aperture of a pyramidal horn antenna |
| c | Length of pyramidal horn antenna |
| $C(x)$ | Fresnel integral |
| D | Diameter of the aperture of a conical horn antenna |
| d_1 | Distance from mirror image of transmit antenna to the aperture of ideal absorber wall |
| d_2 | Distance from the aperture of an ideal absorber wall to receiving antenna |
| D_m | Effective maximum dimension of the antenna aperture |
| E_0 | Electric field strength at the position of an ideal absorber (Annex A) |
| E_r | Receiving electric field strength in the case that an ideal absorber has a square-shaped aperture with size $2a$ (Annex A) |
| E_{s0} | Receiving electric field strength in the case that ideal absorber is not put (Annex A) |
| G_d | Directional gain of horn antenna |
| R | Distance from the aperture of horn antenna to the specimen |
| R_a | Receiving level in the case that the test specimen is put on the specimen holder (dB) |
| R_m | Receiving level in the case that the reference metal plate is put on the specimen holder (dB) |
| S_{11} | Reflection coefficient |
| S_{21} | Transmission coefficient |
| $S(x)$ | Fresnel integral |
| V_a | Receiving voltage in the case that the test specimen is put on the specimen holder |
| V_d | Receiving voltage by direct wave from the transmitting and receiving antenna |
| V_m | Receiving voltage by the reflected wave from the metal plate with the same cross section and shape as the test specimen |
| V_r | Receiving voltage by the reflected wave except for the test specimen |

Table 2 (continued)

| Symbol | Meaning |
|---------------|---|
| V_s | Receiving voltage by the reflected wave only from the test specimen |
| β | Phase constant ($=2\pi/\lambda$) |
| Γ_a | Receiving level in the case that the electromagnetic absorber is put on the specimen holder (vector quantity) |
| Γ_m | Receiving level in the case that the reference metal plate is put on the specimen holder (vector quantity) |
| Γ_r | Receiving level in the case that the test specimen is not put on the specimen holder (vector quantity) |
| ϵ_r' | Real part of relative permittivity |
| θ | Incident angle of electromagnetic wave |
| λ | Wavelength of electromagnetic wave in free-space |

4 Specimen

4.1 Specimen specification

It is recommended that the specimen have a flat surface and rigid structure having a dimension equal to or larger than $10 \lambda_l$, where λ_l is the wavelength of the EM wave at the lowest frequency in the measurement frequency range. However, detailed specifications are given in each type of the three measurement methods described in Clauses 9, 10, and 11.

4.2 Reference metal plate

4.2.1 Material and thickness

Aluminium, copper, stainless steel or other metal, which has thickness of about 1 mm to 2 mm, is preferred.

4.2.2 Surface roughness

The surface roughness of a reference metal plate should be less than $\lambda_m/10$, although less than $\lambda_m/20$ is preferred, where λ_m is the wavelength that corresponds to maximum frequency in the measurement frequencies range. For example, if the maximum frequency is 300 GHz, then λ is 1 mm, and the preferable roughness becomes 0,05 mm.

4.2.3 Flatness

It is recommended that the flatness be less than 0,5 mm for a reference metal plate with size 1 m × 1 m.

4.2.4 Size and shape

The reference metal plate should have the same size and same projection shape normal to the specimen surface. However, it is desirable to use the size specified by each method in Clauses 9, 10, and 11. Care should be taken in selecting the size of the reference metal plate because the reflection and scattering characteristics may depend on its size due to the Fresnel refraction. The dependence of the reflection and scattering characteristics on the size in the case of the horn antenna method is illustrated in Annex A.

4.3 Reference specimen for calibration

The reference specimen for calibration should be silica-glass plate or sapphire single crystal (001) plate with uniform thickness and smooth surface roughness. Relative permittivity should

be known in advance. When dielectric material is selected, it is necessary to measure the reflectivity of the specimen without putting anything on the backward surface of the reference specimen. The reference specimen should be fixed by a material such as foamed plastics, which has relative permittivity near to 1, and in which EM waves do not reflect like they do in free space. It is recommended to verify the accuracy of the measurement system by comparing the measured reflectivity with the theoretical one. The reflectivity of a silica-glass plate measured in the millimetre wave range is given in Annex B.

5 Specimen holder

A specimen holder might be different by the any type of measurement method mentioned in Clauses 9, 10, and 11. It should be recommended that the specimen holder possess functions for adjusting azimuth and elevation.

6 Measurement equipment

The equipment must be calibrated according to the procedure established by the manufacturers, or calibration laboratories accredited by ISO/IEC 17025. The items to be calibrated include frequency, voltage, and attenuation, which depend on the measurement accuracy or uncertainty of the measurement apparatuses. Correct usage of the measurement equipment is very important in order to obtain the exact results. The measurement of the reflectivity of EMA shall be performed using either a VNA or SNA. When there are discrepancies in the measured results, it is necessary to make calibration of the measurement system using a reference specimen. Various necessary apparatuses should be selected according to the type of used measurement methods as shown below.

6.1 Type of network analyzer

The VNA is recommended because it can measure both the magnitude and phase of S_{11} and S_{21} and it has a time domain function.

The SNA can measure only the magnitude of S_{11} and S_{21} .

6.2 Antenna

6.2.1 Horn antenna

Both a commercial as well as an in-built horn antenna can be used for the reflectivity measurement of EMA except in special cases. However, the commercial horn antenna is recommended in order to obtain the required measurement accuracy, which has an accurate gain, VSWR, and size. The commercial coaxial-waveguide transducer is also recommended where the VSWR or sizes are verified in each frequency band. The specifications of some commercial horn antennas are shown in Annex C.

6.2.2 Lens antenna

Not only a dielectric lens antenna but also a metal plate lens antenna or Luneberg lens antenna can also be used for the reflectivity measurement of EMA in this standard. Either a commercially available or an in-built product can also be applicable. However, the use of a commercial lens antenna, in which antenna gain, VSWR, and sizes are specified, will be recommended in order to realize the required measurement accuracy. The specifications of commercial horn antennas and dielectric lenses are illustrated in Annex C.

6.3 Amplifier

An amplifier is generally used in order to get a sufficient dynamic range for the measurement system. The warming up of the amplifier is required and the temperature should be kept as

constant as possible because the total gain of the amplifier will vary due to the temperature drift as it is described in Clause 7.

6.4 Cable

Degradation in transmission characteristics of cables must be checked in the measurement frequency range when the cables are connected directly.

7 Measurement condition

7.1 Temperature and environment

The measurement should be carried out in the atmosphere from 860 hPa to 1 060 hPa, and in the room from 5 °C to 35 °C, and relative humidity from 45 % to 85 %. If the operation temperature and humidity range of the measurement apparatuses are narrower than the above range, the specifications of the measurement apparatuses should be followed. It is desirable to control the measurement temperature within ± 3 °C in order to suppress the influence of the temperature drift of measurement apparatuses to a minimum. The measurement temperature or humidity of the specimen should be specified when the reflectivity depends on temperature or humidity.

7.2 Warming up of measurement equipment

The warming-up time, typically from 15 min to 45 min, must be written in the specifications of the measurement equipment or systems. Moreover, the warming up time should be taken to be longest among all of the measurement equipment.

7.3 Electromagnetic environment

When the EM wave power density in the measurement environment exceeds that specified in public regulations, and when the EM environment is judged to be negative, the measurement should be carried out in an anechoic room. When the directional gain of an antenna is large, however, an anechoic chamber may not necessarily be required.

8 Calibration of measurement system and measurement conditions

8.1 Calibration of measurement system

Calibration of the measurement system must be carried out according to the recommended methods by NWA. Typical calibration methods are shown in Annex D. If the temperature at which the measurement system is calibrated is within ± 3 °C of the measurement temperature, measurement errors can be minimized. However, if the measurement temperature is outside of the range of ± 3 °C, then it is recommended to carry out the calibration again.

8.2 Measurement conditions

8.2.1 Dynamic range

Both the receiving levels with and without the reference metal plate must be measured initially when the measurement system is set up. Dynamic range is defined as the difference of these measured values in decibels. Annex E illustrates the relation between the dynamic range and the measurement error. If the dynamic range of the measurement system is 40 dB and reflectivity of specimen is -20 dB, an error bar lies from $-0,92$ dB to $+0,83$ dB.

8.2.2 Setting up of the network analyzer for keeping adequate dynamic range

The dynamic range of the measurement system can be increased by modifying the IF band or by utilizing the averaging function of NWA when the dynamic range does not exceed a

necessary value. The dynamic range increases by use of the isolation calibration of the VNA as shown in Annex F.

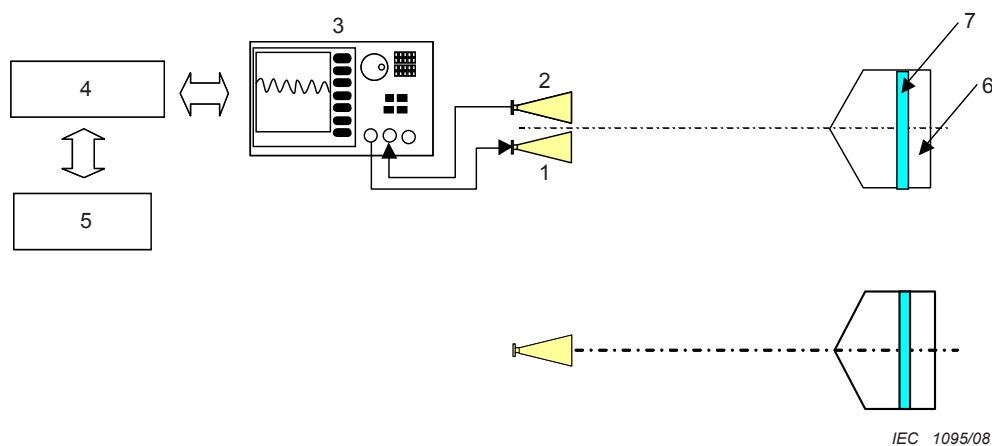
9 Horn antenna method

9.1 Measurement system

9.1.1 Configuration of the measurement system

Figure 2 and Figure 3 show a block diagram of the measurement system. The arrangement of transmitting and receiving antennas, and the block diagram of the measurement system in the horn antenna method are illustrated below for normal and oblique incidence measurement. For measuring the transmission coefficient S_{21} , a pair of antennas is used, whereas only one antenna is used for measuring the reflection coefficient S_{11} in normal incidence.

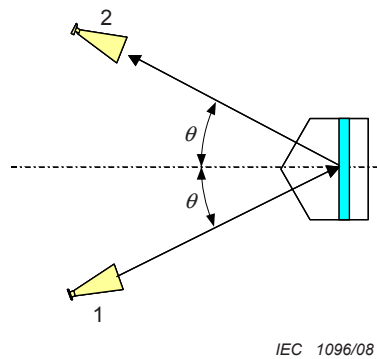
For the case of oblique incidence, transmitting antenna should be arranged in such a way that the central axis makes the same angle to the normal direction of the specimen surface with that of receiving antenna. Here, if S_{21} is measured using two horn antennas in normal incidence, then the vertical alignment of transmitting and receiving antennas should be fixed within 5° . The measurement equipment including a NWA is given in Clause 6.



Key

- 1 Tx antenna
- 2 Rx antenna
- 3 VNA/SNA
- 4 Computer
- 5 Printer
- 6 Specimen holder
- 7 Specimen

Figure 2 – Configuration of the measurement system normal incidence (S_{11})

**Key**

- 1 Tx antenna
- 2 Rx antenna

**Figure 3 – Configuration of the measurement system
oblique incidence (S_{21})**

9.1.2 Horn antenna

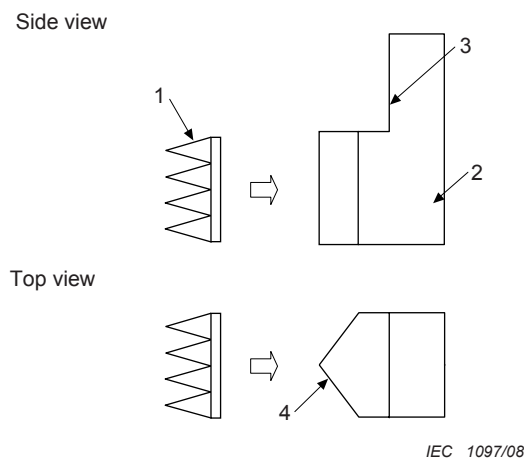
Both a commercial as well as an in-built horn antenna can be used for the reflectivity measurement of EMA except in special cases. Before measuring the reflectivity, it is necessary to calculate the directional gain of the horn antenna to determine the distance from the antenna to the specimen. The directional gain, VSWR and sizes must be checked from the catalogue when a commercial horn antenna is used.

9.1.3 Specimen holder**9.1.3.1 Material and shape****9.1.3.1.1 Material**

The reflection of the EM wave from the specimen holder can be minimized by making use of foamed polystyrene with a high foaming ratio as a specimen holder, because foamed plastics have a very low relative permittivity (near 1). Annex G shows relative permittivity of foamed polystyrene as a function of the foaming ratio.

9.1.3.1.2 Shape

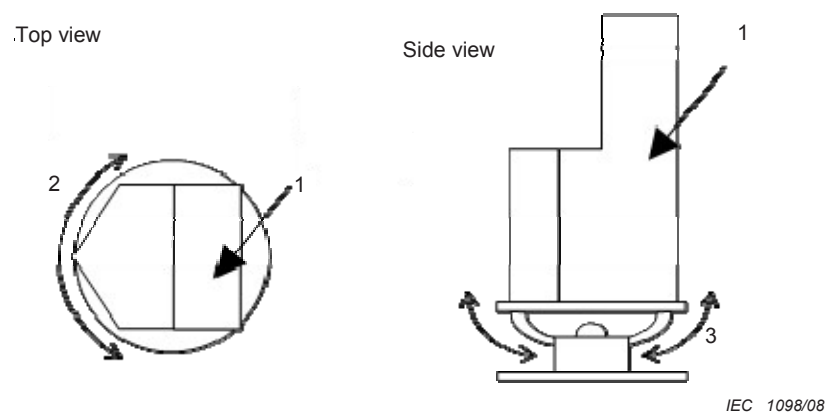
The shape in normal projection to the specimen surface and the area of a specimen holder which mounts a specimen should be equal to those of the specimen in order to suppress the reflection of the EM wave from the specimen holder. The uncovered portion of the specimen holder should be covered by a pyramidal-type wave absorber, and the shape of the uncovered portion should have a wedge form as illustrated in Figure 4.

**Key**

- 1 Pyramidal EMA
- 2 Specimen holder
- 3 Mounting point of specimen
- 4 Wedge form

Figure 4 – Mounting method of specimen**9.1.3.2 Azimuth and elevation angle adjustment function**

Figure 5 shows elevation angle adjustment as well as the lifting and descending mechanism. An azimuth table under the specimen holder, which has the mechanism adjusting the elevation and the azimuth angle, should be installed in order to enable the accurate installation of the specimen with respect to transmitting antenna. Accuracy of elevation and directional angle should be about $0,1^\circ$.

**Key**

- 1 Specimen holder
- 2 Azimuth angle adjustment function
- 3 Elevation angle adjustment function

Figure 5 – The mechanism of adjusting azimuth and elevation

9.1.4 Mounting of the specimen

Either double-sided adhesive tape, simple paste or thin cellophane tape is used to fix the reference metal plate and specimen to the specimen holder.

9.1.5 Antenna stand

Attention should be paid to covering up a stand by a pyramidal-type wave absorber, although the quality of the material of the stand that mounts a transmitting antenna does not necessarily have to be that of products fabricated from rosin or wood.

9.2 Measurement conditions

9.2.1 Measurement environment

The measurement should not necessarily be performed in an anechoic chamber, which depends on the directional gain of the antenna. However, it is required that there be no obstacle in the direction of the main beam of the horn antenna. If the obstacle cannot be removed, such as a screen of a pyramidal-type, EMAs must be installed on the path of the EM wave. When the oblique incidence characteristics are measured, the floor and roof should also be covered with the pyramidal-type EMA, because the reflected EM wave from them has the same path length as that from the specimen in many cases.

9.2.2 Measuring distance

When the EM waves are radiated from the rectangular aperture of a horn antenna, the distance, R , which separates Fresnel region from the Fraunhofer region, the boundary between the two may be arbitrarily taken to be at Equation (2), where D_m is an effective maximum dimension of the antenna aperture, and λ is the wavelength. The directional gain, G_d of the horn antenna is represented by Equation (3). From Equations (2) and (3), the range of R representing the Fraunhofer region can be expressed by Equation (4) using G_d .

$$R \geq 2D_m^2 / \lambda \quad (2)$$

$$G_d = 4\pi D_m^2 / \lambda^2 \quad (3)$$

$$R \geq G_d \lambda / 2\pi \quad (4)$$

It is desirable to keep the distance between the specimen and the antennas greater than the right hand side of Equation (4), which depends on the measurement frequency, and which becomes longest at the lower limit of the measurement frequency range. Annex H shows the relation between the directional gain of the antenna and the measuring distance.

9.2.3 Size of specimen

It is recommended that the size of the specimen should be larger than 100 mm × 100 mm for the reflectivity measurement using the horn antenna method. If the size of the specimen is smaller than 100 mm × 100 mm, a very accurate adjustment of azimuth and elevation angles should be done.

9.3 Measurement procedures

Measurement is carried out according to the following steps after installation of measurement equipment based upon the conditions described in Subclause 9.2.

a) Adjust the measurement system

- 1) Set up the transmitting and receiving antennas and specimen holder according to each measurement condition; normal or oblique incidence, distance between specimen and antennas, etc.
- 2) Set up the transmitting and receiving antennas in such a way that their heights will be at the centre of the specimen, and adjust the horn antenna so that the aperture may be perpendicular to the horizontal plane using a spirit level.
- 3) Set up the reference metal plate on the specimen holder, and adjust the elevation angle so that the reference metal plate may be perpendicular to the horizontal plane using a spirit level.
- 4) Set up the position and normal direction of the reference metal plate so that the receiving level of the scattered EM wave may become maximum by rotating the metal plate through $\pm 10^\circ$ of directional angle using an azimuth turn table.
- 5) Check the dynamic range of the measurement system. Measure the receiving level of the reference metal plate at the measurement frequency range. Remove the reference metal plate and measure the receiving level. Calculate the dynamic range, the difference of the two levels in decibel. Carry out the isolation calibration according to Subclause 8.2.2 when the desired dynamic range is not obtained.

b) Measurement using scalar network analyzer

- 1) Set up the reference metal plate on the specimen holder, and measure the receiving level, R_m (dB).
- 2) Replace the reference metal plate by the specimen on the specimen holder, and measure the receiving level, R_a (dB).
- 3) Calculate the reflectivity of specimen by subtracting the receiving level R_m (dB) from receiving level, R_a (dB).

c) Measurement using vector network analyzer

- 1) Set up the reference metal plate on the specimen holder. Measure the vector quantities of the receiving level, Γ_m .
- 2) Remove the reference metal plate from the specimen holder, and measure the receiving level, Γ_r , without the specimen.
- 3) Mount the specimen on the specimen holder, and measure the vector quantities of the receiving level, Γ_a .
- 4) Subtract the vector quantities of the receiving levels Γ_r from Γ_m , and subtract the undesired waves other than those reflected directly from the EMA.
- 5) Transform the vector quantities into time domain data from frequency domain data, and apply time gating for the main response from the EMA only.
- 6) After the time gating is applied, transform the responses into the frequency domain receiving level, R_m (dB), of the reference metal plate.
- 7) Subtract the vector quantities of the receiving level, Γ_r , from the vector quantities of the receiving level, Γ_a , of the specimen, and subtract the undesired waves.
- 8) Transform the obtained vector quantities into the time domain from the frequency domain data, and apply time gating for the main response only.
- 9) After the time gating is applied, these responses are retransformed into the frequency domain data, receiving level, R_a (dB), of the specimen.
- 10) Calculate the reflectivity of specimen by subtracting the receiving level, R_m (dB), of the reference metal plate from the receiving level, R_a (dB), of the specimen.

10 Dielectric lens antenna method – focused beam method

10.1 Outline

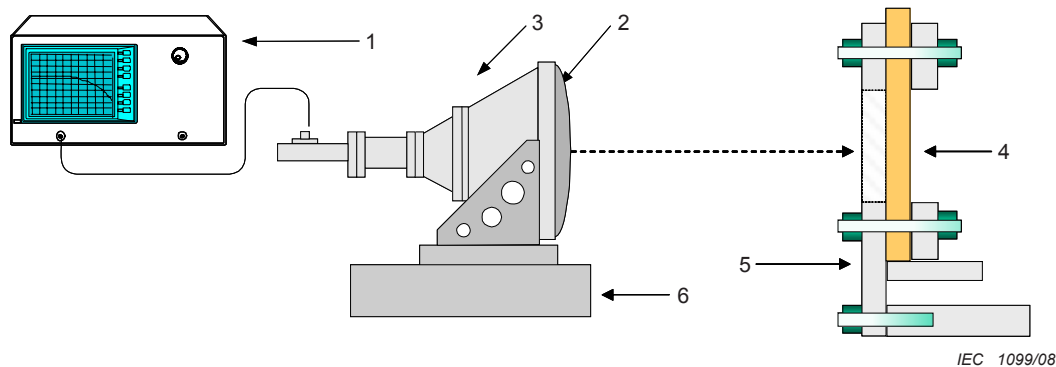
A method which uses a focused beam type horn antenna has the following characteristics.

- A large measurement space may not necessarily be required because the focused EM wave has a beam waist of several wavelengths and has a nearly flat phase-front on the focal plane.
- A sufficient dynamic range can be easily obtained because the EM wave does not spread over into the surroundings.
- The measurement can not necessarily be carried out in an anechoic chamber in cases where the large dynamic range is not required because the scattered EM waves in the surroundings cannot easily come to a receiving antenna.
- When the EMA is inhomogeneous, the reflectivity of the EMA may depend on the surface position, where the EM wave beam is incident, because the beam waist diameter of the focused EM wave is rather small, about $3\lambda - 5\lambda$, on the surface of the EMA.

10.2 Measurement system

10.2.1 Transmitting and receiving antennas

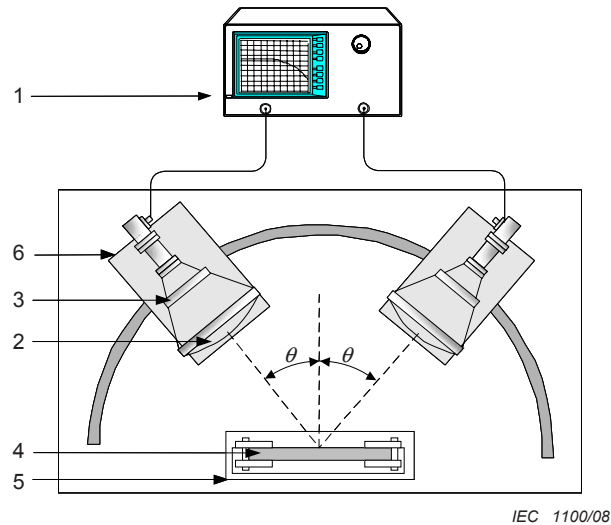
A block diagram of the measurement system is shown in Figure 6 and Figure 7. Figure 6 and Figure 7 show the measurement system for normal incidence (side view), and oblique incidence (top view), respectively. In the case of normal incidence, the reflection coefficient S_{11} is measured using only one antenna. In the case of oblique incidence, the transmitting and receiving antennas are mounted so that the incident and reflection angle of the EM wave is equal ($=\theta$) with respect to the normal to the specimen. In order to remove the spurious reflection signals which do not come from the specimen, it is desirable to use a VNA with time domain and time gating functions.



Key

- | | |
|-------------------|-------------------|
| 1 VNA | 4 Specimen |
| 2 Dielectric lens | 5 Specimen holder |
| 3 Horn antenna | 6 Antenna holder |

Figure 6 – Measurement system for normal incidence (side view)

**Key**

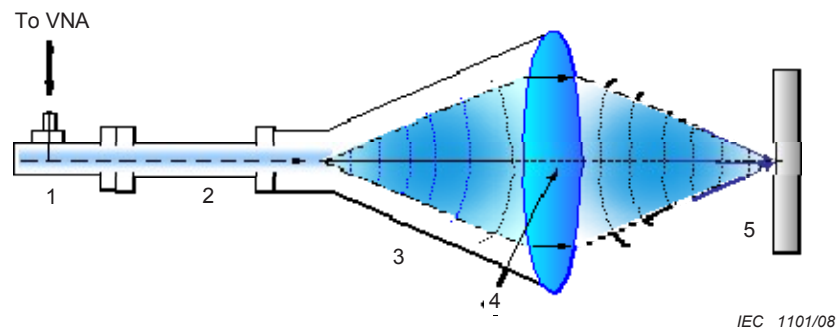
- | | |
|-------------------|-------------------|
| 1 VNA | 4 Specimen |
| 2 Dielectric lens | 5 Specimen holder |
| 3 Horn antenna | 6 Antenna holder |

Figure 7 – Measurement system for oblique incidence (top view)

10.2.2 Focused beam horn antenna

10.2.2.1 Antenna structure

Figure 8 shows the structure of an antenna with a dielectric lens used in the focused beam method which is composed of a coaxial-waveguide transducer, a mode conversion feed that converts a linearly-polarized EM wave to a circularly-polarized one, circular horns, and convex-type dielectric lens. The EM waves radiated from the antenna gradually converge at the focus, where the minimum beam waist of the EM wave becomes several wavelengths. The focal length is determined by both curvature of a convex-type dielectric lens and the relative permittivity of the lens material. The amplitude of the EM wave at the beam waist changes as Gaussian as a function of the radial distance away from the central axis of the lens, which takes maximum at the centre of the focus. The phase at the focus does not depend so strongly on the radial distance because both the path (electric length) that is transmitted through the centre of the lens and the path (electric length) that is transmitted through the peripheral part of the lens are nearly equal. Some specifications of a commercial dielectric lens antenna, such as diameter, focal length, and lens material etc., are shown in Annex C, Clause C.2.

**Key**

- 1 Coaxial-waveguide transducer
- 2 Mode converter
- 3 Horn antenna
- 4 Dielectric lens
- 5 Specimen

Figure 8 – Structure of a dielectric lens antenna

10.2.2.2 Measurement range

A different coaxial-waveguide transducer and a different rectangular-circular mode conversion feed must be prepared for the different frequency band in Figure 8.

10.2.2.3 Antenna positioner

An antenna positioner must be prepared for accurate measurement of normal or oblique incidence, which enables the transmitting and receiving antennas to be moved along the central axis and the moved distance to be measured accurately. Moreover, an antenna holder should have a function so that the incident angle of the EM wave may be varied with respect to the normal direction of the specimen surface.

10.2.3 Specimen size

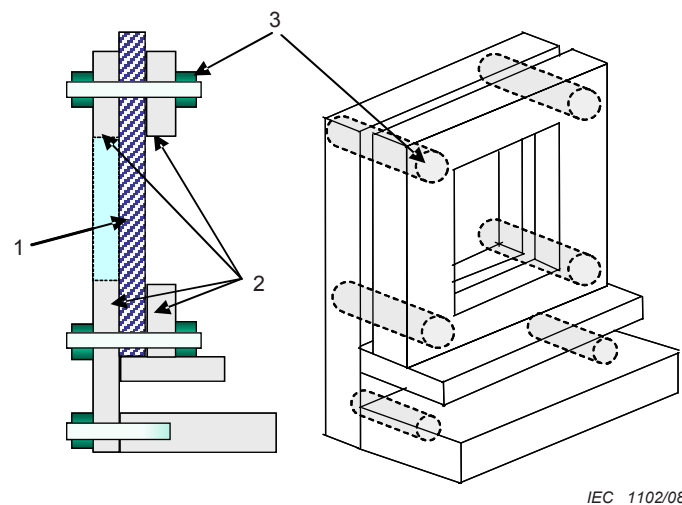
Each length of the specimen sides should be at least larger than 3 times the diameter of the largest beam waist at the lowest frequency of the measuring frequency range.

10.2.4 Reference metal plate size

The reference metal plate should have the same area and shape in normal projection to specimen surface.

10.2.5 Specimen holder**10.2.5.1 Material and size**

A specimen holder is illustrated in Figure 9. The specimen holder is made of a resinous material, polycarbonate plastics, which has a relatively low permittivity near 1 and does not reflect EM waves as strongly at the holder surface. The specimen holder should have a rigid structure without any swing or vibration. In the case of normal incidence, the size should be larger than 3 times the beam waist, and preferably as large as possible. Therefore a structure able to set a large or small specimen is preferred. In the case of oblique incidence angle θ , the size of the specimen holder is made larger than in normal incidence, because the irradiated specimen surface area becomes larger than in normal incidence by $1/\cos\theta$.

**Key**

- 1 Specimen
- 2 Poly-carbonate frame
- 3 Poly-carbonate screw and nut

Figure 9 – Structure of specimen holder**10.2.5.2 Adjustment of azimuth and elevation angle**

To install the specimen accurately, a specimen holder should have a function to manipulate the elevation and azimuth angles. Azimuth and elevation angles are adjusted to the most appropriate values so that the receiving level may become maximal after a reference metal plate is put instead of the specimen.

10.2.6 Method of fixing the specimen and the reference metal plate

The four sides of the specimen or the reference metal plate should be tightly fixed on the specimen holder so that bending may not occur.

10.3 Measurement procedures

Measurement is carried out according to the following steps after installation of measurement equipment based upon the conditions described in Subclause 9.2.

- a) Adjust the measurement system
 - 1) Set the position of the specimen holder properly such that the specimen surface is just at the focal point of a dielectric lens antenna.
 - 2) Other adjustments of the measurement system are performed according to Subclause 9.3.1.
- b) Measurement using vector network analyzer
 - 1) Set up the VNA so as to measure S_{11} for normal incidence measurement and S_{21} for oblique incidence measurement.
 - 2) Set up the reference metal plate on the specimen holder. Measure the vector quantities of the receiving level, Γ_m .

- 3) Remove the reference metal plate from the specimen holder, and measure the receiving level, Γ_r , without the specimen.
 - 4) Subtract the vector quantities of the receiving levels Γ_r from Γ_m , and subtract the undesired waves other than those reflected directly from the reference metal plate.
 - 5) Transform the vector quantities into time domain data from frequency domain data, and apply time gating for the main response from the reference metal plate only.
 - 6) After the time gating is applied, transform the responses into the frequency domain receiving level, R_m (dB), of the reference metal plate.
 - 7) Mount the specimen on the specimen holder, and measure the vector quantities of the receiving level, Γ_a .
 - 8) Remove the specimen from the specimen holder, and measure the vector quantities of the receiving level, Γ_r .
 - 9) Subtract the vector quantities of receiving level, Γ_r , from the vector quantities of the receiving level, Γ_a , of the specimen, and subtract the undesired waves.
 - 10) Transform the obtained vector quantities into the time domain from the frequency domain data, and apply time gating for the main response only.
 - 11) After the time gating is applied, these responses are retransformed to the frequency domain data, receiving level, R_a (dB), of the specimen.
 - 12) Calculate the reflectivity of the specimen by subtracting the receiving level, R_m (dB), of the reference metal plate from the receiving level, R_a (dB), of specimen.
- c) Measurement using a vector network analyzer and its calibration function
- Types and details of calibration of NWA are described in Annex D.
- 1) Set up the VNA so as to measure S_{11} for normal incidence measurement and S_{21} for oblique incidence measurement.
 - 2) Select the type of calibration, “ S_{11} reflection response and isolation calibration” for S_{11} mode, and “ S_{21} transmission response and isolation calibration” or “ S_{21} transmission response calibration” for S_{21} mode. For S_{21} mode, the undesired waves are generally low that “ S_{21} transmission response calibration”, which does not include isolation calibration, can be selected. In such a case, the step d) is omitted.
 - 3) Set up the reference metal plate on the specimen holder. Measure the vector quantities of the receiving level, Γ_m . For S_{11} mode, the VNA is calibrated with “Short”, and for S_{21} mode, the NWA is calibrated with “Thru”.
 - 4) Remove the reference metal plate on the specimen holder. Measure the vector quantities of the receiving level, Γ_r , in the case that there is no specimen on the holder. For both S_{11} and S_{21} mode, the NWA is calibrated with “Isolation”.
 - 5) Finish a series of calibrations by making the calibration function of the VNA become active.
 - 6) Set up the specimen on the specimen holder, and measure the receiving level.
 - 7) Transform the obtained vector quantities of f) into the time domain from frequency domain data, and apply time gating for the main response only.
 - 8) After the time gating is applied, these responses are retransformed to the frequency domain data, receiving level, R_a (dB), of the specimen.

11 Dielectric lens antenna method – parallel beam method

11.1 Principle

11.1.1 Outline

In the parallel beam method, the EM wave, radiated from the transmitting antenna, is deflected to be a parallel beam using a dielectric EM wave lens and the transmitted wave is incident on the specimen. The reflected EM wave level is measured using a horn antenna after being transmitted through a dielectric lens.

This method has the following characteristics.

- a) A large measurement room is not usually required because the spherical equi-phase front of the EM wave from a horn antenna can be converted to a quasi-plane phase front near the focal point.
- b) An anechoic chamber is not always necessary, because enough of a dynamic range is generally achieved, since the EM waves scattered into the surrounding cannot easily invade the receiving ports.
- c) In oblique incidence, it is possible to make a measurement at a large incident angle, because the EM wave beam is quasi-paralleled by the dielectric lens.

11.1.2 Parallel EM wave beam formed using a EM wave lens

The wavelength of the millimetre wave, several mm, is generally far smaller than the distance between the antenna and the specimen. An EM wave lens can be realized similarly to an optical lens based upon the ray theory. There exist a dielectric lens, a metal plate lens etc., as typical EM wave lenses. Figure 10 shows the effect of using a dielectric lens. The secondary phase error on the specimen surface can be compensated, and an EM wave with planer equi-phase front and high energy density can be obtained, hereafter called parallel beam, if a dielectric lens is put in front of a horn antenna. If a dielectric lens is used, side-lobes are suppressed due to the low radiation power on the end portion of a dielectric lens. The horn antenna with a dielectric lens has the following characteristics.

- a) Side lobes can be suppressed because there is no obstacle on the forward direction between a horn antenna and a dielectric lens.
- b) Reflection from a lens can be easily reduced by coating the lens surface with anti-reflection film.

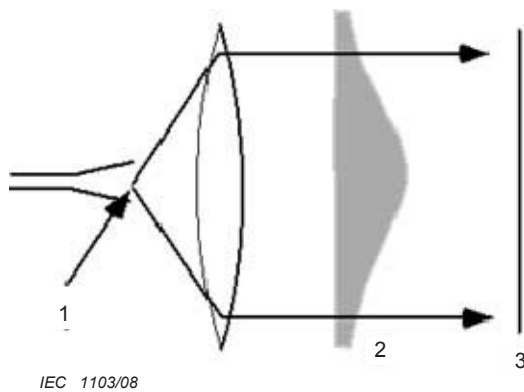


Figure 10a – Construction

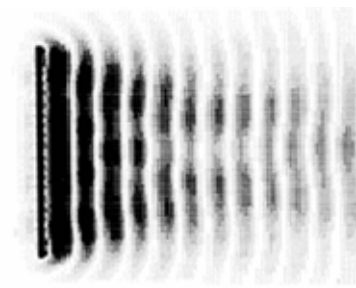


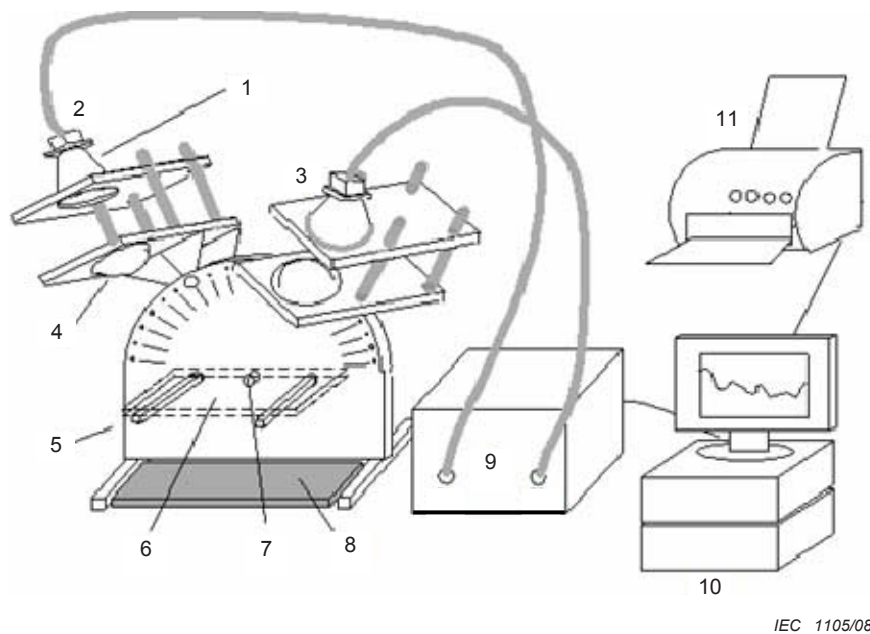
Figure 10b – Equi-phase plane

Key

- 1 Radiation source of EM wave
- 2 Field distribution
- 3 Equi-phase plane pattern

Figure 10 – EM wave propagation using a horn antenna and a dielectric lens**11.2 Measurement system****11.2.1 Composition of measurement system**

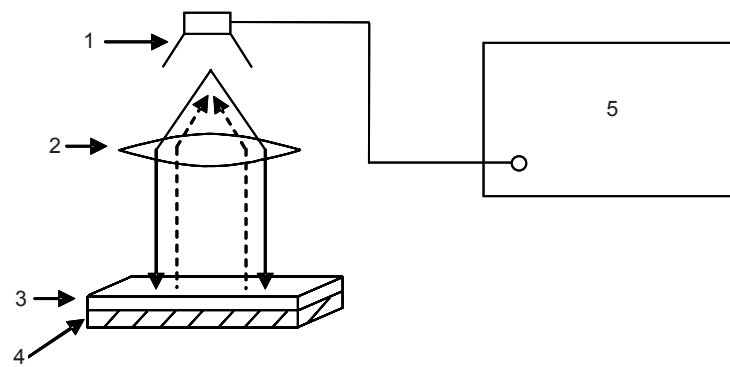
An example of a measurement system is shown in Figure 11. The specimen surface is kept normal to the plane of incidence. A specimen holder has a structure applicable to the measurement for oblique incidence. The directions of both antennas are adjusted such that incident and reflection angle may be equal by maximizing the reflection level of the receiving antenna.

**Key**

- | | | | |
|---|----------------------|----|-------------------|
| 1 | Horn antenna | 7 | Rotary shaft |
| 2 | Transmitting antenna | 8 | EM absorber |
| 3 | Receiving antenna | 9 | VNA/SNA |
| 4 | Dielectric lens | 10 | Personal computer |
| 5 | Specimen holder | 11 | Printer |
| 6 | Specimen | | |

Figure 11 – Block diagram of the measurement system**11.2.1.1 Normal incidence**

Figure 12 shows the block diagram of a measurement system for normal incidence. One dielectric lens and a horn antenna are used. Reflection coefficient S_{11} is measured using a NWA. In order to remove the multiple reflections, a VNA is used which has the time domain function in order to extract only the reflected wave with required time gating width.



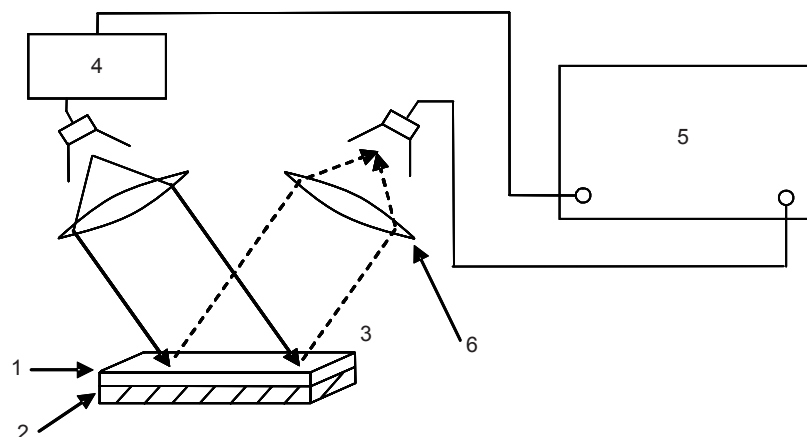
IEC 1106/08

Key

- | | | | |
|---|-----------------------|---|-------------|
| 1 | Horn antenna | 4 | Metal plate |
| 2 | Dielectric lens | 5 | VNA |
| 3 | Plane for calibration | | |

Figure 12 – A measurement system for normal incidence**11.2.1.2 Oblique incidence**

Figure 13 shows the block diagram of a measurement system for oblique incidence. Transmission coefficient S_{21} is measured by using both dielectric lenses in transmitting and receiving antennas, respectively. In the case of oblique incidence, the spurious EM wave is decreased due to the scattering of the EM wave by multiple reflections. Therefore, usually, the time domain and gating functions of the VNA are not necessarily used. For this reason, a SNA can also be used. In high accuracy measurement, however, it is required to extract the reflected wave only from the specimen using the time domain and gating functions of VNA.



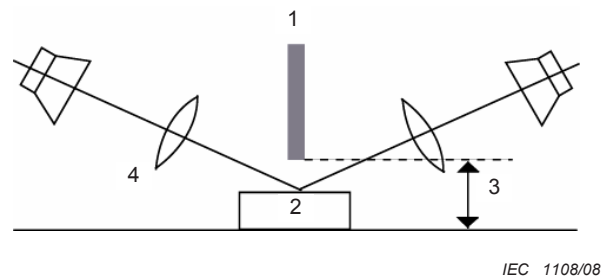
IEC 1107/08

Key

- | | | | |
|---|-----------------------|---|------------------------|
| 1 | Plane for calibration | 4 | Millimetre wave module |
| 2 | Metal plate | 5 | VNA/SNA |
| 3 | Specimen | 6 | Dielectric lens |

Figure 13 – Measurement system for oblique incidence

For incident angles larger than 70° , besides the correctly-reflected wave from specimen, the direct coupling between the transmitting and receiving antennas occurs. In this case, a shielding plate of an EM absorber should be used as shown in Figure 14. The calibration of the system should be performed including isolation. See Annex D.



Key

- | | | | |
|---|----------------------------|---|----------------------------------|
| 1 | Shielding plate of EM wave | 3 | Distance without direct coupling |
| 2 | Specimen | 4 | Dielectric lens |

Figure 14 – Position of a shielding plate

11.2.2 Dielectric lens antenna

11.2.2.1 Diameter of dielectric lens and surface roughness

The diameter of the lens is selected to be more than 10 times of the wavelength. Surface roughness must be less than $1/16 \lambda$. An example of specifications or sizes of dielectric lens is given in Annex C.

11.2.2.2 Horn antenna

A horn antenna is set so that the virtual source point of the antenna comes to the focal point of a dielectric lens. The position of the virtual source is illustrated in Annex C.

11.2.2.3 Distance between specimen and dielectric lens

The distance between a specimen and a lens is taken from 2,5 to 5 times of the diameter of the dielectric lens in order to avoid the near field region of the EM waves at the dielectric lens.

11.3 Specimen

11.3.1 General

In the case that dielectric lenses are used, the transmitted wave is not a plane wave, and the equi-phase front is not planar but is curved if it is away from the central axis, which leads to a decrease in the magnitude of the EM wave field. If the maximum phase difference of the EM wave within the specimen surface is less than $22,5^\circ$, i.e. $1/16$ of the wavelength, the decrease in the EM wave field is usually less than -10 dB. The error in reflectivity may be small for a larger specimen.

11.3.2 Reference metal plate

A metal plate with sizes equal to the specimen and made of aluminium or copper should be prepared.

11.3.3 Size of specimen

Each side of a specimen must be larger than 10λ where λ is the wavelength of the EM wave. In case of oblique incidence, it is desirable to take a larger path distance between the incident and reflected wave for the large incident angle. In order to remove the undesired reflections, EMAs are often put in the backward side of the reference metal plate and specimen.

11.4 Measurement procedures

11.4.1 Normal incidence

When the measurement is performed with a normal incidence the following steps shall be followed.

- a) Prepare a coaxial cable which connects the transmitting port of VNA and horn antenna. Connect the coaxial cable to the transmitting port of the VNA, and connect the other end of the cable to the horn antenna.
- b) Put the reference metal plate on the surface of the specimen, each side of which is larger than the diameter of dielectric lens, and carry out a response calibration using “Short” only. Next, optimize the gating time. Rotate and adjust the specimen mount in such a way that reflection from the metal plate would be maximal, and measure the reflectivity of the reference metal plate, R_m (dB).
- c) Put the specimen so that the upper surface will come at the same position as the reference plane, and measure the reflectivity of the specimen, R_a (dB). Calculate the reflectivity of the specimen by subtracting the receiving level, R_m (dB) of the reference metal plate from the receiving level, R_a (dB), of the specimen.

NOTE One horn antenna is used in the rigorous measurement of normal incidence. However, the measurement of oblique incidence by making the incident angle as small as approximately 5° can be usually assumed to be the same as normal incidence.

11.4.2 Oblique Incidence

11.4.2.1 Measurement using a VNA

When the measurement is performed with an oblique incidence and a VNA the following steps shall be followed.

- a) Adjust the spatial direction of an antenna properly according to the polarization of TE or TM waves.
- b) Set the transmitting and receiving antennas so as for the incident and reflection angles to be equal, respectively, and connect coaxial cables to each horn antenna. Put the reference metal plate at the same height of the specimen surface, and perform “Thru” calibration. Note that each side of the metal plate must be greater than the diameter of the dielectric lens.
- c) Optimize the gating time and width for measuring the reflectivity from the reference metal plate. Rotate the specimen mount in such a way that reflection from the reference metal plate is maximal, and measure the reflection from the reference metal plate, R_m (dB). If a wider dynamic range is required, “Isolation” calibration should be performed. See Annex F.
- d) Place the specimen so that its upper surface will come at the same height as the reference plane, and measure the reflection, R_a (dB).
- e) Calculate the reflectivity of the specimen by subtracting the receiving level, R_m (dB), of the reference metal plate from the receiving level, R_a (dB), of the specimen.

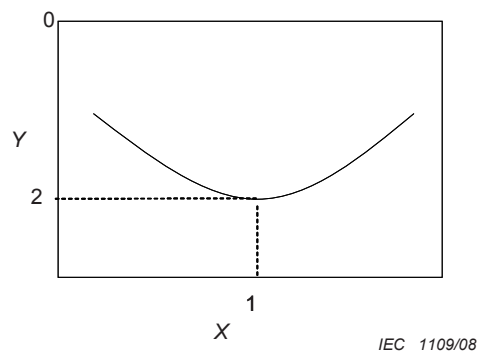
11.4.2.2 Measurement using a SNA

When the measurement is performed with an oblique incidence and a SNA the following steps shall be followed.

- a) Adjust the spatial direction of an antenna according to the polarization for TE wave or TM wave.
- b) Connect a coaxial cable to the transmitting port of the SNA and to the transmitting antenna, and another coaxial cable to the receiving port of the SNA and to the receiving antenna.
- c) Fix the transmitting and receiving antennas so that the incident and reflection angles may be equal. Connect coaxial cables to each horn antenna. Put the reference metal plate on the sample holder so that its height may be at the same height as the specimen surface. Set the SNA to the transmission measurement state. Note that each side of the reference metal plate must be larger than the diameter of the dielectric lens.
- d) Adjust the specimen holder such that the reflected signal level of the EM wave from the reference metal plate may become maximum. Calibrate the SNA.
- e) Put the specimen on the specimen holder so that the upper surface will come to the same height as that of the previous reference metal plate. Measure the reflectivity of the specimen, R_a (dB).

12 Test report

- a) A test report should be written in order to include the experimental results properly in the written form where the experimental conditions are indicated by the following terms.
- b) In a test report, indicate the specimen product type and name if possible. Product type may include material, shape, and composition of layers. Include the dimension of the specimen.
- c) The measurement results of the reflectivity of a specimen should be expressed in a table or graph form. Moreover, the measurement result of a dynamic range shall also be specified. Refer to Figure 15.
- d) It is necessary to enlist the used test equipment in the test report. It is also desirable to mention the manufacturer's model and latest calibration date.
- e) The reflectivity of the specimen is expressed in terms of dB. The unit of frequency is in terms of GHz.
- f) Describe the measurement method of the reflectivity of the specimen and the measurement procedures.
- g) Describe the measurement environment of the reflectivity of the specimen. Also mention whether the environment is an anechoic chamber or an indoor environment. Moreover, the measurement conditions (frequency range, number of points, averaging) of a NWA should also be indicated.

**Key**

- X Frequency [GHz]
- Y Reflectivity [dB]
- 1 Matching frequency f_m
- 2 Reflectivity at f_m

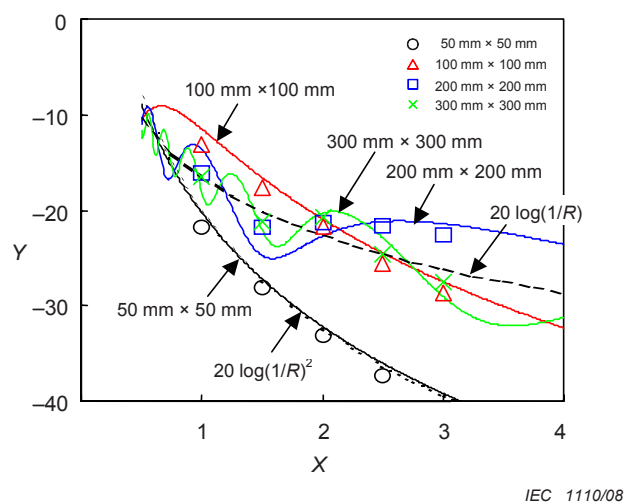
Figure 15 – Items to be mentioned in a test report

Annex A (informative)

Reflection and scattering from metal plate – Horn antenna method

A.1 Reflection characteristics

Figure A.1 shows the reflectivity of metal plates versus distance from the antenna for several aluminium plate sizes from 50 mm × 50 mm to 300 mm × 300 mm with thickness 2 mm at 40 GHz. Figure A.2 shows the reflectivity when the plates are positioned at 2 m from the transmitting and the receiving antennas. The reflectivity is defined as the received level of EM waves by the receiving antenna transmitted by a transmitting antenna through a direct path of 2 m length. The reflectivity of several metal plate sizes was measured. The curve, which was fitted to the measured data, was calculated using Kirchhoff's and Huygens' diffraction theory. The relation of the reflectivity of the reference metal plate to the distance from the transmitting antenna can be well explained by Kirchhoff's and Huygens' diffraction theory. Exact reflectivity data could not be obtained sufficiently when the specimen size is smaller than $\sqrt{(d_1 d_2 \lambda / (d_1 + d_2))}$ even if the sides of the metal plate are longer than the free-space wavelength λ . Therefore the measurement distance, i.e. the distance between the transmitting and the receiving antennas, should be carefully selected.

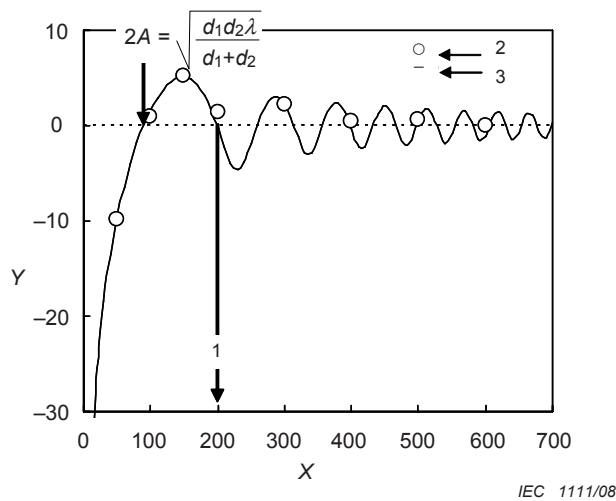


Key

X Measurement distance (m)

Y Reflection level (dB)

Figure A.1 – Reflection from the reference metal plate versus measurement distance between the antenna and the metal plate



Key

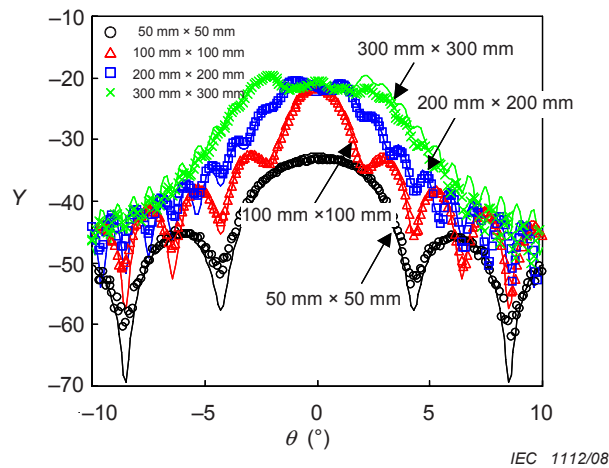
- 1 1st Fresnel zone
- 2 Measured data
- 3 Calculated data
- X Dimension of a metal plate edge (mm)
- Y Reflectivity (dB)

The measurement distance is 2 m.

Figure A.2 – Reflectivity of reference metal plate versus size

A.2 Scattering characteristics $\theta \cong 0^\circ$

The reflectivity of the EM wave from metal plates of various sizes is shown in Figure A.3 when the distance between the antennas and a metal plate is set to be 2 m. The dependence of the measurement distance upon the reflectivity of a metal plate with a cross section of 200 mm × 200 mm is shown in Figure A.4. The incident angle θ of the EM wave, where the maximum reflectivity is obtained, depends upon the reference metal plate size and the distance from the antennas. Nearly flat reflectivity curve at around $\theta \cong 0^\circ$ was obtained when the metal plate size is large or the distance between the metal plate and the antennas is short. This flat angular dependence is not desirable because the exact direction of the incident or transmitted EM wave cannot be determined simply from maximizing the measured signal level of the network analyzer.

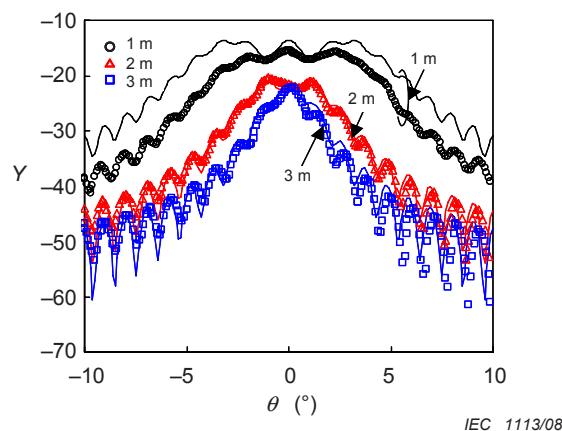
**Key**

θ Incident angle

Y Reflection level (dB)

The distance between the plate and the antenna is 2 m.

Figure A.3 – Reflectivity of reference metal plate at 40 GHz

**Key**

θ Incident angle

Y Reflection level (dB)

Distance between the plate and the antenna is 2 m.

Figure A.4 – Reflectivity of reference metal plate with cross section of 200 mm x 200 mm at 40 GHz

NOTE Analysis of the reference metal plates – Kirchhoff's and Huygens' diffraction theory: Several methods of analyzing the reflection wave from the metal plate have been proposed, such as a FDTD method and the equivalence theorem, a method of physical optics approximation, where Kirchhoff's and Huygens' principle is used in the present analysis. Here, the metal plate is replaced by the infinite wall with a slot. The infinite wall is completely opaque to the electromagnetic waves, i.e. the perfect absorbing wall. According to Kirchhoff's and Huygens' principle, when an infinite perfect absorbing half-wall is placed to $y = \pm\infty$ at $x = -A$ in the distance from a conveyance wave path, the electric field strength E_r in a receiving point of z-axis is given by

$$E_r = \frac{jE_0 e^{-j\beta d_2}}{\lambda d_2} \int_{-\infty}^{+\infty} dy \int_{-A}^{+\infty} e^{-j\beta(x^2+y^2)(d_1+d_2)/2d_1d_2} dx \quad (\text{A.1})$$

where E_0 is electric field strength in origin which put an infinite perfect absorbing half-wall, β is phase constant, i.e. $2\pi/\lambda$, d_1 is distance from an origin to a source point, and d_2 is from an origin to a receiving point.

It should be noted that E_r is represented by the electric field strength E_{s0} without an infinite perfect absorbing half-wall as follows.

$$\frac{E_r}{E_{s0}} = \sqrt{\frac{j}{2}} \left(\frac{1-j}{2} + C(w) - jS(w) \right) \quad (\text{A.2})$$

$$w = A \sqrt{\frac{2(d_1+d_2)}{d_1d_2\lambda}}$$

where $C(w)$ and $S(w)$ are Fresnel integrals. When a uniform plane wave is incident on an infinite perfect absorbing wall having a square slot of width $2A$, as shown in Figure A.5, E_r is given by

$$\frac{E_r}{E_{s0}} = (1 - 2\psi(w))(1 - 2\psi(w)) \quad (\text{A.3})$$

$$\psi(w) = \sqrt{\frac{j}{2}} \left(\frac{1-j}{2} + C(w) - jS(w) \right)$$

where d_1 is the distance between the perfect absorbing wall and the image of the transmitting antenna, and d_2 is the distance between the perfect absorbing wall and the actual transmitting and receiving antennas.

Annex B (informative)

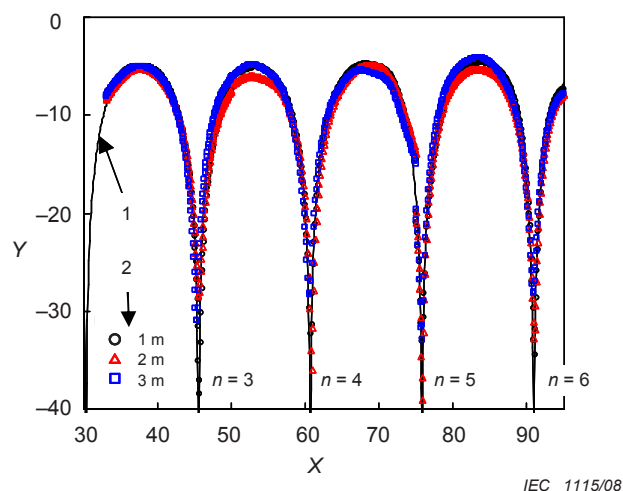
Reflectivity of reference specimens using horn antenna method

B.1 Reference material

The complex relative permittivity of quartz glass has been measured and compared in round robin tests by using the S-parameter method and cut-off cylindrical waveguide method. The value of relative permittivity is 3,80 – 3,82, and $\tan\delta$ is of order 10^{-4} , extremely small value.

B.2 Reflectivity of the reference material

Figure B.1 shows the reflectivity from a quartz glass plate with a cross section of 200 mm × 200 mm and thickness 5,07 mm for the measurement distance 1 m, 2 m, and 3 m, respectively, in the frequency range from 33 GHz to 95 GHz, when a metal plate behind it is removed. The experimental data are plotted with circles, rectangles, and squares, and the solid curve is calculated theoretically using the complex relative permittivity of the quartz, $3,80 - j\theta$, which is determined by S-parameter method. All these measurement data and the theoretical curve are in good agreement not only at the matching frequency but also at other frequencies. The difference between the measured and calculated results outside the matching frequency is from $\pm 0,5$ dB to ± 1 dB.



Key

- 1 Calculated data
- 2 Measured data
- X Frequency (GHz)
- Y Reflectivity (dB)

Figure B.1 – Reflectivity of a 200 mm × 200 mm silica-glass plate in millimetre wave frequency

Annex C (informative)

Specifications of commercially available antennas

C.1 Horn antennas

Figure C.1 and Table C.1 show the structure and dimensions of commercially available pyramidal horn antennas with antenna gain of 24 dB for several frequency bands.

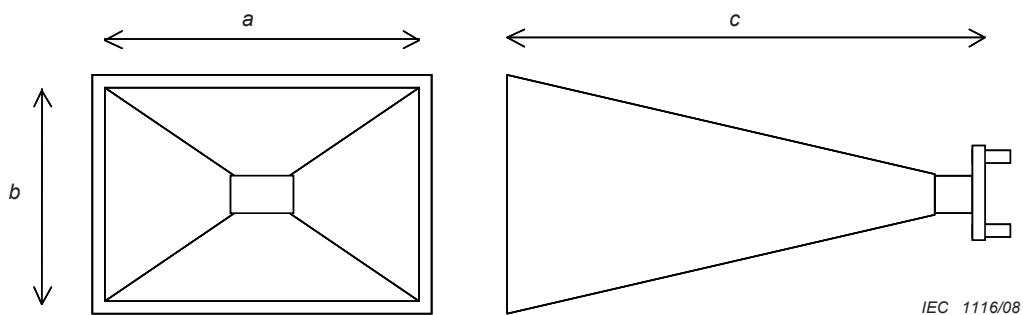


Figure C.1 – Representative specifications of a horn antenna

Table C.1 – Antenna gain 24 dB (example A)

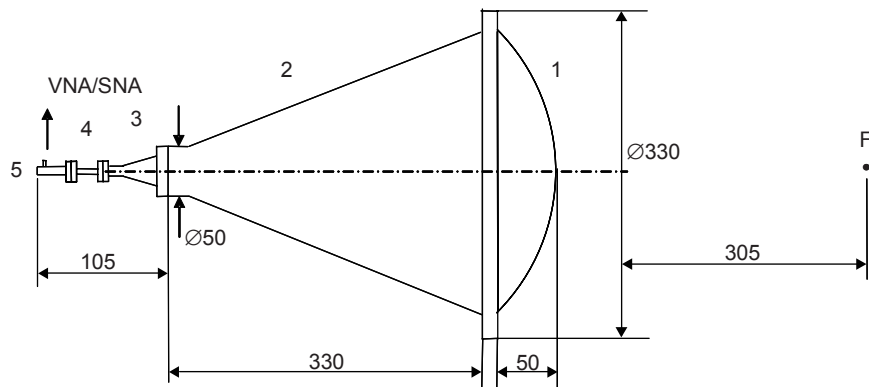
| Frequency GHz | Waveguide | <i>a</i> mm | <i>b</i> mm | <i>c</i> mm |
|------------------|-----------|----------------|----------------|----------------|
| 33~50 | R-400 | 55,1 | 41,9 | 103,4 |
| 40~60 | R-500 | 46,3 | 35,2 | 88,4 |
| 50~75 | R-620 | 36,4 | 27,7 | 70,5 |
| 60~90 | R-740 | 30,0 | 22,8 | 59,6 |
| 75~110 | R-900 | 24,6 | 18,7 | 49,2 |
| 90~140 | R-1200 | 19,7 | 15,0 | 39,6 |
| 110~170 | R-1400 | 16,0 | 12,2 | 32,1 |
| 140~220 | R-1800 | 12,5 | 9,6 | 26,3 |
| 170~260 | R-2200 | 10,6 | 8,1 | 21,2 |
| 220~325 | R-2600 | 8,4 | 6,4 | 18,0 |

C.2 Antennas consisting of dielectric lens

Table C.2, Figure C.2 and Figure C.3 show specifications and sizes for several kinds of horn antennas with dielectric lenses.

Table C.2 – Some specifications of antennas with dielectric lenses

| Type | Diameter mm | Focal distance mm | Material | Method |
|------|----------------|----------------------|--------------|---------------|
| A | 305 | 305 | Polyethylene | Focused beam |
| B | 175 | 175 | PTFE | " |
| C | 175 | 275 | " | " |
| D | 120 | – | " | Parallel beam |

Dimensions are in millimetres

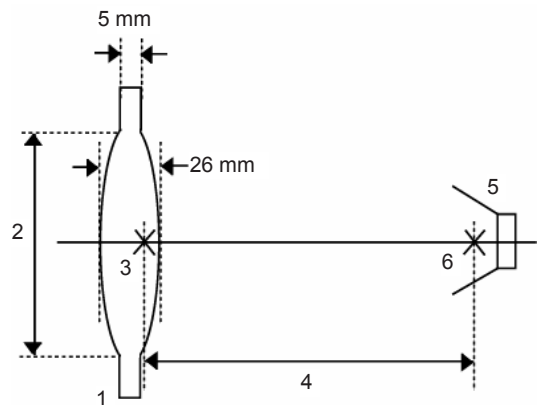
IEC 1117/08

Key

- 1 Dielectric lens
- 2 Cylindrical horn antenna
- 3 Conical tip
- 4 Mode converter
- 5 Coaxial-waveguide adapter
- F Focus

For use of another frequency range, parts 3, 4, and 5 are exchanged.

Figure C.2 – Structure of cylindrical horn antenna with dielectric lens in Table C.2, A used at 50 GHz - 75 GHz



IEC 1118/08

Key

- 1 Dielectric lens (radius of curvature 175 mm)
- 2 Diameter of lens
- 3 Principal point (optical centre)
- 4 Focal length (200 mm)
- 5 Horn antenna
- 6 Estimated virtual source point of electromagnetic wave

The type of horn antenna is selected from Table C.1 according to the measurement frequency range.

Figure C.3 – A structure of dielectric lens and horn antenna in Table C.2, D

Annex D (normative)

Calibration using VNA

D.1 Type of calibration

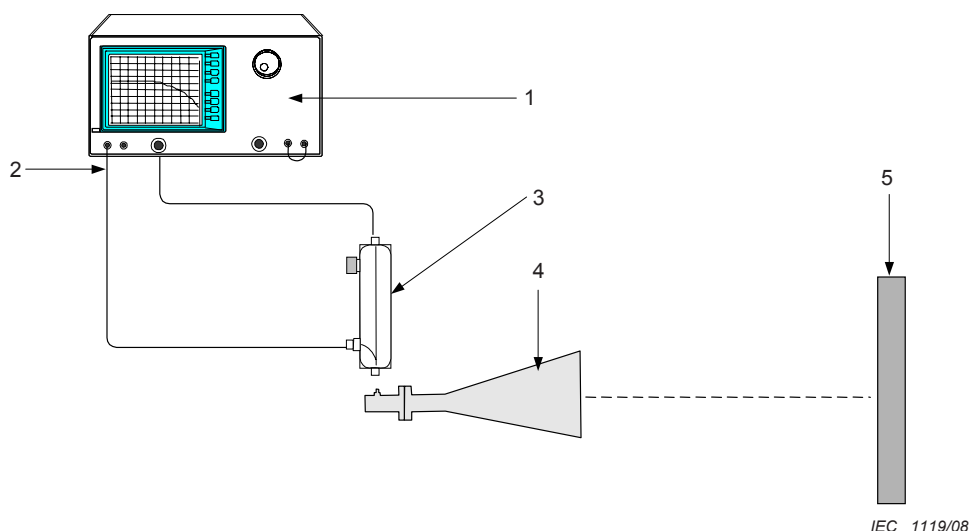
The types of calibration of VNA are classified as mentioned below.

D.1.1 In case of normal incidence

- a) S_{11} response calibration
- b) S_{11} response/Isolation calibration

In the case of normal incidence where only one antenna with no dielectric lens is used, the reflection level within the internal test set of the VNA and antenna connection is sometimes larger than that from the reference metal plate or the specimen, which leads to the degradation of dynamic range and that of reproducibility of the measurement. This situation may be improved by the following procedures.

- 1) Minimize the length of measurement cables.
- 2) Utilize the coaxial cable of low loss type.
- 3) Connect a directional coupler with directivity larger than 20 dB outside of the VNA as shown in Figure D.1. The reflection signal is fed to the additional input port of NWA. When NWA has no additional input port, the reflection signal is fed to test port 2, in which case VNA must be set in S_{21} mode, not in S_{11} mode.
- 4) Calibrate the measurement system with S_{11} response/isolation calibration, not with S_{11} response calibration.
- 5) Utilize the dielectric lens antenna.



Key

- 1 VNA with an additional input port
- 2 Additional input port
- 3 Directional coupler with high directivity
- 4 Horn antenna
- 5 Specimen or reference metal plate

Figure D.1 – Measurement configuration for the case of normal incidence with a directional coupler connected directly to the horn antenna

D.1.2 In case of oblique incidence

- a) S_{21} response calibration
- b) S_{21} response/isolation calibration

In the measurement of oblique incidence in which both the transmitting and receiving antennas are used, the calibration of the measurement system is effectively performed because it does not suffer from limitation of the dynamic range of the directional coupler.

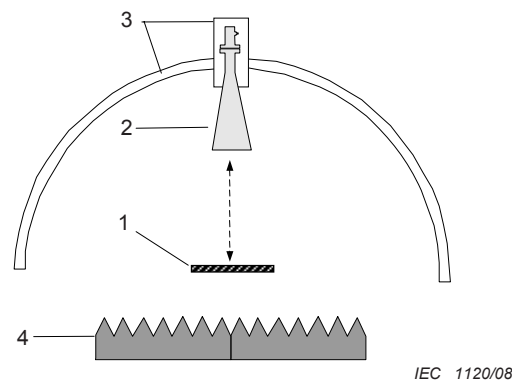
D.2 Calibration procedures

When the calculation of calibration is performed by using NWA, the definition table of calibration for each calibration standard must be created in each type of VNA. The calibration procedures and steps are summarized as follows.

D.2.1 S_{11} and S_{21} response calibration

As shown in Figure D.2 and Figure D.3, a reference metal plate is used as only one standard. This type of calibration is most simple. However, it can not escape from direct coupling of the antenna, impedance mismatching at connections of the antenna, and spurious reflection from the specimen holder. So that it is desirable to utilize the time domain and gating functions of NWA.

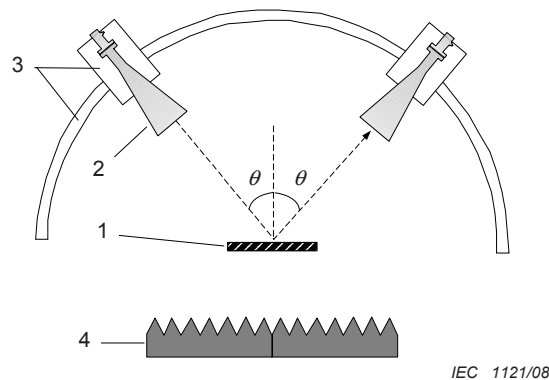
- a) Put a reference metal plate with the same size as a specimen on the specimen holder.
- b) Measure the reflection level.
- c) Make response calibration active.
- d) Measure the reflection level of the specimen in comparison with the reference metal plate which is prepared as a reference standard for total reflection.



Key

- 1 Reference metal plate
- 2 Horn antenna
- 3 Antenna mount
- 4 EM wave absorber

Figure D.2 – Configuration for response calibration using a reference metal plate in the case of normal incidence



Key

- 1 Reference metal plate
- 2 Horn antenna
- 3 Antenna mount
- 4 EM wave absorber

Figure D.3 – Configuration for response calibration using a reference metal plate in the case of oblique incidence

D.2.2 S_{11} and S_{21} response and isolation calibration

As shown in Figure D.4 and Figure D.5, the two standards, a reference metal plate and a no-reflection standard, are used. For a no-reflection standard, nothing is put on the specimen holder, and the wall behind the specimen holder should be well separated, so that the reflection from the wall may be minimized. For accurate reflectivity measurement, the calibration described in this section is more appropriate than the response calibration. Further, more exact measurement can be done by using the time domain and gating functions of the NWA.

- a) Put a reference metal plate with the same size as a specimen on the specimen holder.
- b) Measure reflection level ("Response" calibration).
- c) Remove the reference metal plate and the obstacles behind the sample holder which reflect the EM wave.
- d) Measure the reflection level ("Isolation" calibration).
- e) Make response and isolation calibration of NWA active.
- f) Measure the reflectivity of the specimen when the reference metal plate is assumed as a 100 % reflection standard and the configuration with no specimen on the specimen holder as a no-reflection standard.

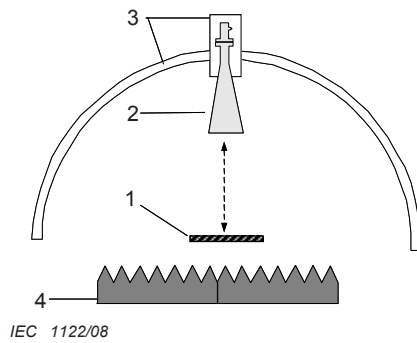


Figure D.4a – Response calibration

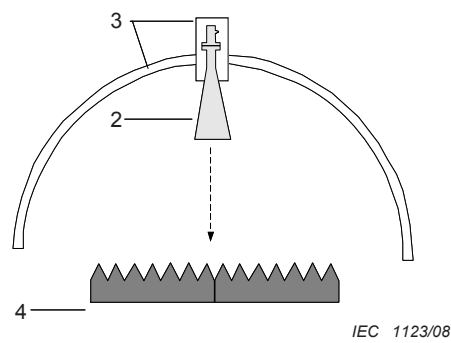


Figure D.4b – Isolation calibration

Key

- 1 Reference metal plate
- 2 Horn antenna
- 3 Antenna mount
- 4 EM wave absorber

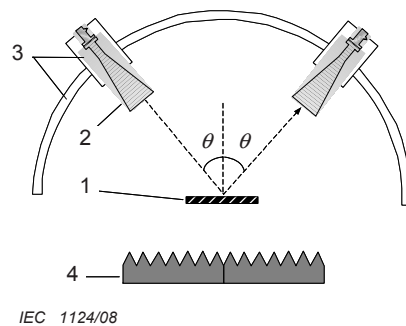
Figure D.4 – Configuration for response and isolation calibration in the case of normal incidence

Figure D.5a – Response calibration

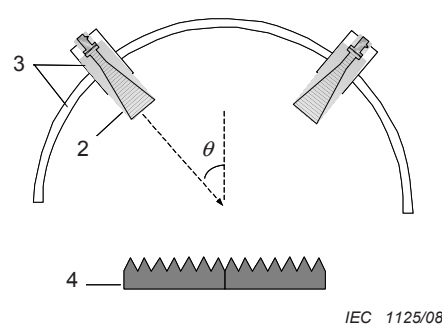


Figure D.5b – Isolation calibration

Key

- 1 Reference metal plate
- 2 Horn antenna
- 3 Antenna mount
- 4 EM wave absorber

Figure D.5 – Configuration for response and isolation calibration in the case of oblique incidence**D.2.3 S₁₁1-port full calibration (“Short-A quarter wavelength offset short-load” calibration)**

This type of calibration is applied for accurate reflectivity measurement when only an antenna is used for normal incidence. Impedance matching of the measurement port can be calibrated, which is not the case with simple response calibration. The configuration is shown in Figure D.6. It is required that the specimen holder and antenna mount must be positioned with

accuracy smaller than $1/100 \lambda_m$ of the EM wave, where λ_m is the wavelength that corresponds to maximum frequency in the measurement frequency range.

- a) Put a reference metal plate with same size as a specimen on the specimen holder.
- b) Measure the complex reflection level (“Short” calibration).
- c) Move the receiving antenna or the specimen holder by the distance $\lambda/4$, where λ is the free space wavelength at the central frequency in the measurement range. A very accurate positioning is required for the calibration.
- d) Measure the complex reflection level (A quarter wavelength “Offset Short” calibration).
- e) Return the antenna or the specimen holder to its original position, and remove the reference metal plate. Remove as many reflection objects as possible behind the specimen holder.
- f) Measure the complex reflection level (“Load” calibration).
- g) Calculate the error parameters of the 1-port model. Make S_{11} 1-port calibration of VNA active.
- h) Measure the specimen, and compensate the error of the measured value.

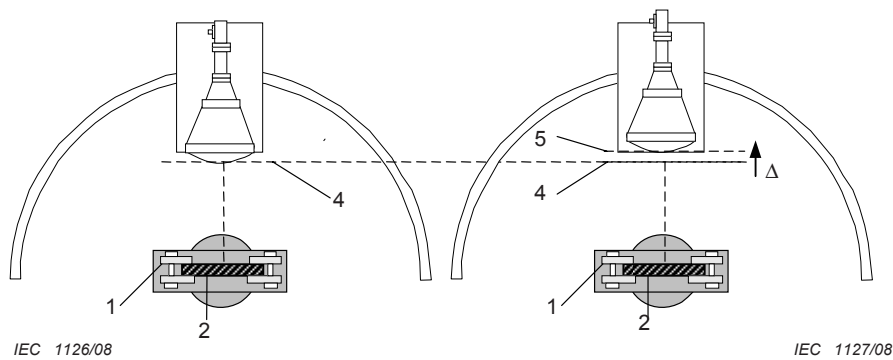


Figure D.6a – “Short” calibration

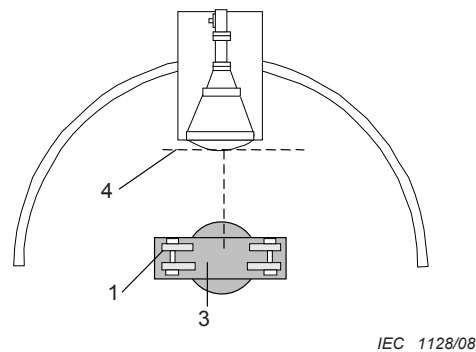
Figure D.6b – $1/4 \lambda$ “Offset Short” calibration

Figure D.6c – “Load” calibration

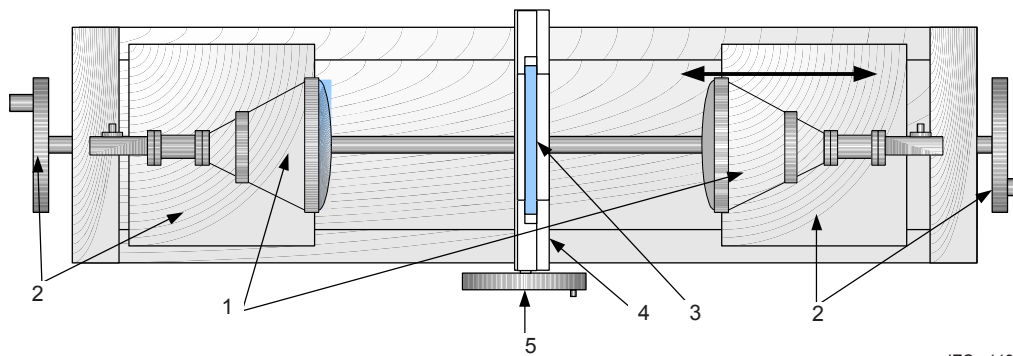
Key

- 1 Specimen holder
- 2 Reference metal plate
- 3 Configuration with specimen removed
- 4 Measurement position
- 5 $1/4 \lambda$ “Offset” position

Figure D.6 – Configuration for S_{11} 1-port full calibration in the case of normal incidence

D.2.4 TRL 2-port calibration

Instead of performing 1-port full calibration, it is possible to measure reflectivity by using only 1 port antenna after performing 2-port full calibration. This procedure is mainly used in the measurement method described in Clause 10. TRL calibration is most appropriate for 2-port full calibration. In order to perform TRL calibration, a VNA, a pair of antennas and an antenna positioner must be prepared as shown in Figure D.7. It is required that the specimen holder and antenna mount must be positioned with accuracy smaller than $1/100 \lambda_m$ of the EM wave, where λ_m is the wavelength that corresponds to maximum frequency in the measurement frequency range.



IEC 1129/08

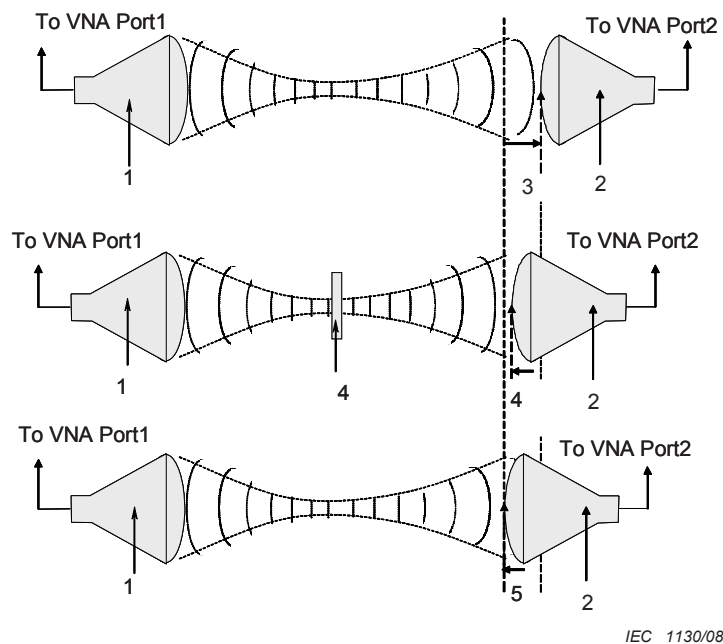
Key

- 1 Dielectric lens antenna
- 2 Antenna stand and micro-manipulating handle
- 3 Specimen
- 4 Specimen holder
- 5 Specimen holder mount and micro-manipulating handle

Figure D.7 – Precision antenna positioner configuration

As shown in Figure D.8, the calibration is performed as follows.

- a) Put port-1 antenna, specimen holder, and port-2 antenna as shown in Figure D.7. Adjust the two antennas to be in a confocal position.
- b) Take off a specimen or a reference metal plate. Move the port-2 antenna away from the reference position by a quarter wavelength at the central frequency in the measurement range. Perform “Line” calibration.
- c) Put the reference metal plate on the specimen holder. Move the port-2 antenna away from the reference position just by the thickness of the metal plate. Perform “Reflect” calibration.
- d) Return the port-2 antenna to the initial reference position and take off the specimen or the reference metal plate. Perform “Thru” (Through) calibration.
- e) Finish TRL calibration.
- f) Measure the reflectivity S_{11} of the specimen, where only the port-1 antenna is used as shown in Figure D.9. In the actual measurement, it is desirable to isolate the port-2 antenna from the port-1 antenna, by covering the port-2 antenna using an EMA and a metal plate. Separation of port 1 and port 2 antennas should be smaller than -40 dB.

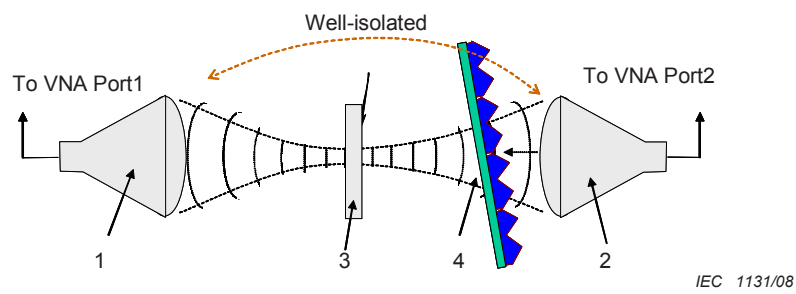
**Key**

- 1 Transmitting antenna
- 2 Receiving antenna
- 3 Position for "Line" calibration
- 4 A reference metal plate and the position for "Reflect" calibration
- 5 Position for "Thru" calibration

From top side, "Line", "Reflect", and "Thru" configurations are shown.

Figure D.8 – TRL calibration procedure

In the millimetre wave frequency, a quarter wavelength at the central frequency becomes smaller than the thickness of the reference metal plate. It is better to perform "Reflection" measurement first, the "Line" calibration second, and "Thru" calibration last. The reason is that motion of only one direction of the micro-manipulator on the antenna positioner can suppress occurrence of the back rush.

**Key**

- 1 Transmitting antenna
- 2 Receiving antenna
- 3 Specimen
- 4 EMA

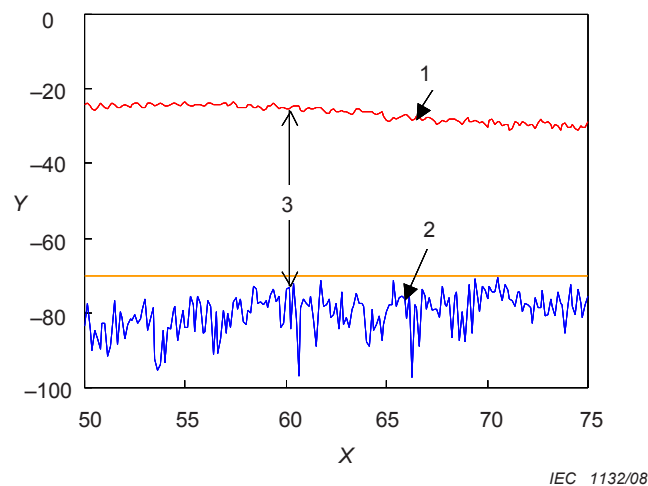
Figure D.9 – Measurement and TRL calibration of transmission line

Annex E (informative)

Dynamic range and measurement errors

E.1 Dynamic range

Dynamic range is defined as the difference in dB between the receiving level from the reference metal plate and the level, which is measured after removing the metal plate. Figure E.1 shows the dynamic range and measurement error. The receiving level is between -80 dB and -70 dB when the metal plate is removed. In the millimetre-wave range, the dynamic range lies between 40 dB and 50 dB when the size of the reference metal plate is larger than $10\lambda \times 10\lambda$, and the distance between the metal plate and the antenna is from 1 m to 3 m.



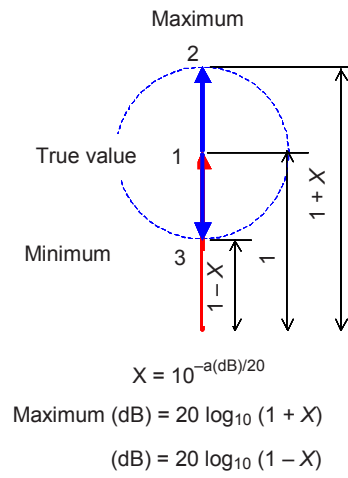
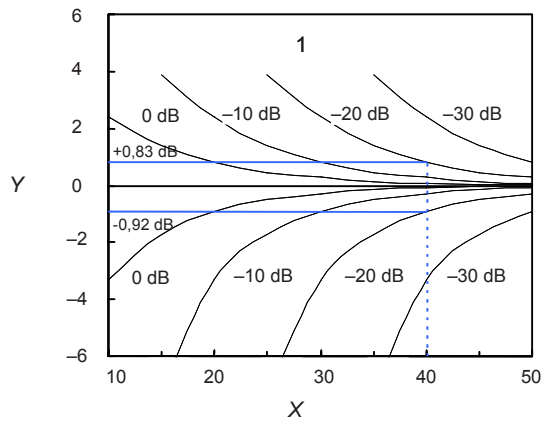
Key

- 1 Reference metal plate 300 mm × 300 mm
- 2 Receiving level without specimen
- 3 Dynamic range
- X Frequency (GHz)
- Y Receiving level (dB)

Figure E.1 – An example of receiving level of a reference metal plate and that without a specimen

E.2 Dynamic range and measurement error

The measured reflectivity may range from -20 dB $- 0,92$ dB to -20 dB $+ 0,83$ dB when the reflectivity is measured for an EM wave absorber with reflectivity of -20 dB and the dynamic range of the system is 40 dB as shown in Figure E.2.



IEC 1133/08

Key

1 Reflectivity

X Dynamic range (dB)

Y Maximum error (dB)

Figure E.2 – Dynamic range and measurement error of reflectivity

Annex F (informative)

Enlargement of dynamic range – Calibration by isolation

In a horn antenna method, the receiving level consists not only of the reflected signal from a specimen, but also of the undesired signals due to such things as the direct wave from a transmit antenna, reflected waves from the specimen holder, and those from the other circumferential objects as shown in Figure F.1.

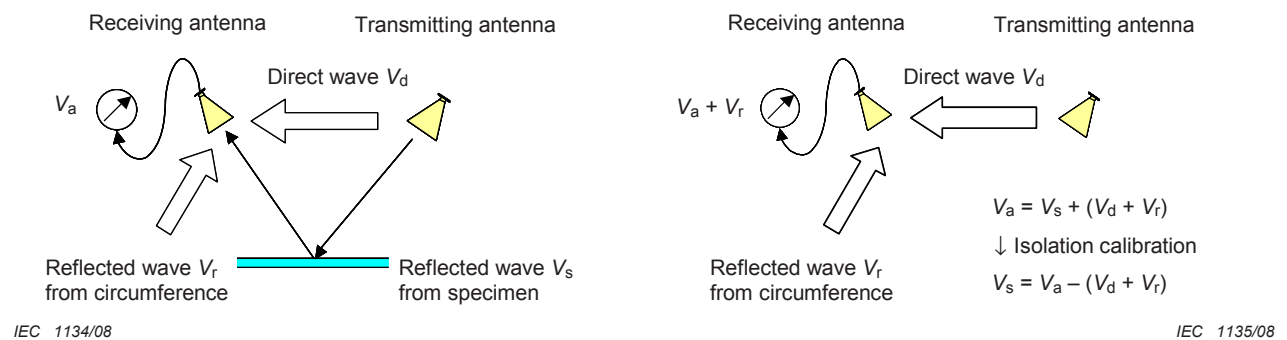


Figure F.1a – Configuration with specimen

Figure F.1a – Configuration without specimen

Figure F.1 – A method to remove spurious waves

Only the reflected waves from the specimen can be extracted from the spurious signals mathematically using the time domain technique. Moreover, there is a method to subtract the undesired waves from total reflected waves in vector quantity.

$$V_s = V_a - (V_d + V_r)$$

where V_a is the measured voltage in the case of a specimen put on a specimen holder, ($V_r + V_d$) are the voltage in the case of no specimen, respectively, i.e. V_d are direct wave voltage, and V_r reflected wave voltage from the specimen holder, and that from nearby objects, respectively. V_s can be obtained simply by subtracting ($V_d + V_r$) from V_a . Moreover, the reflected signal V_s purely from the specimen is obtained, after removing the spurious signals, by transforming V_s to a time-domain signal using for example the time domain function of the VNA, proper gating for the time domain signal, and by transformation into frequency domain data again.

Annex G (informative)

Relative permittivity of styrofoam and foamed polyethylene based on foam ratio

Table G.1 and Table G.2 show the relative permittivity of styrofoam and foamed polyethylene for several values of foaming ratio.

Table G.1 – Relative permittivity and foam ratio of styrofoam

| Foam ratio | ϵ_r' |
|------------|---------------|
| 1 (pure) | 2,65 |
| 20 | 1,083 |
| 30 | 1,055 |
| 40 | 1,041 |
| 60 | 1,028 |

Table G.2 – Relative permittivity and foam ratio of foamed polyethylene

| Foam ratio | ϵ_r' |
|------------|---------------|
| 2 | 1,70 |
| 5 | 1,21 |
| 6 | 1,21 |
| 10 | 1,04 |
| 15 | 1,02 |
| 30 | 1,02 |

Annex H (informative)

Calculation of Fraunhofer region – Horn antenna method

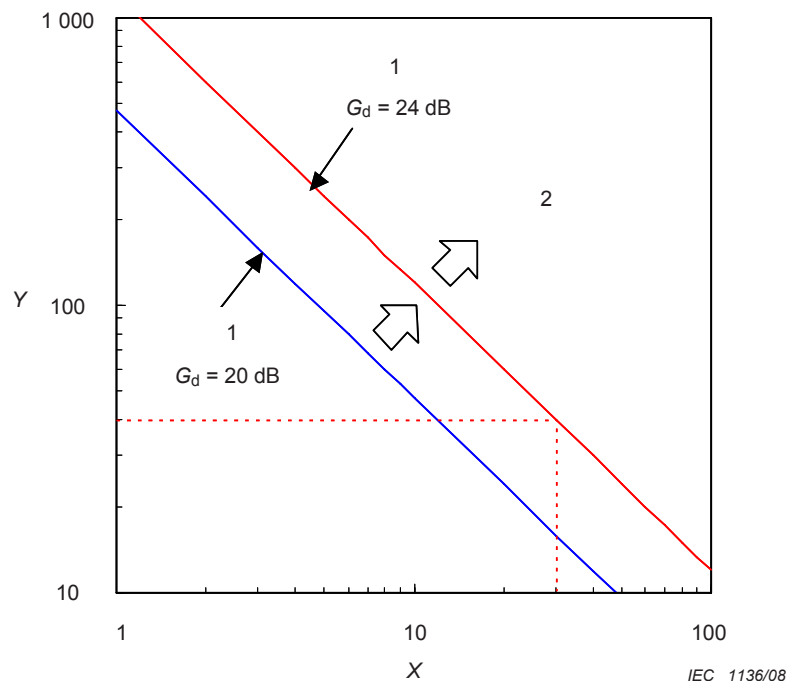
For EM waves radiated from the rectangular aperture of horn antenna, the distance, R , which represents the distance separating the Fresnel from the Fraunhofer region, the boundary between the two may be arbitrarily taken to be at Equation (H.1), where D is the maximum effective dimension of the antenna aperture, and λ is the wavelength. Directional gain, G_d , of the horn antenna is represented by Equation (H.2). From Equations (H.1) and (H.2), the distance R in Equation (H.3) can be obtained.

$$R \geq 2D_m^2 / \lambda \quad (\text{H.1})$$

$$G_d = 4\pi D_m^2 / \lambda^2 \quad (\text{H.2})$$

$$R \geq G_d \lambda / 2\pi \quad (\text{H.3})$$

An example of the calculation using Equation (H.3) is shown in Figure H.1. At 30 GHz, the lower limit of the measurement frequency range, if antenna gain is set to be 24 dB, then R becomes larger than 40 cm. In this case, it is preferred to fix the distance R greater than 1 m.



Key

- 1 Rectangular horn
- 2 Fraunhofer region
- X Frequency (GHz)
- Y Measurement distance (cm)

Figure H.1 – Fraunhofer region and antenna gain

British Standards Institution (BSI)

BSI is the national body responsible for preparing British Standards and other standards-related publications, information and services.

BSI is incorporated by Royal Charter. British Standards and other standardization products are published by BSI Standards Limited.

About us

We bring together business, industry, government, consumers, innovators and others to shape their combined experience and expertise into standards-based solutions.

The knowledge embodied in our standards has been carefully assembled in a dependable format and refined through our open consultation process. Organizations of all sizes and across all sectors choose standards to help them achieve their goals.

Information on standards

We can provide you with the knowledge that your organization needs to succeed. Find out more about British Standards by visiting our website at bsigroup.com/standards or contacting our Customer Services team or Knowledge Centre.

Buying standards

You can buy and download PDF versions of BSI publications, including British and adopted European and international standards, through our website at bsigroup.com/shop, where hard copies can also be purchased.

If you need international and foreign standards from other Standards Development Organizations, hard copies can be ordered from our Customer Services team.

Subscriptions

Our range of subscription services are designed to make using standards easier for you. For further information on our subscription products go to bsigroup.com/subscriptions.

With **British Standards Online (BSOL)** you'll have instant access to over 55,000 British and adopted European and international standards from your desktop. It's available 24/7 and is refreshed daily so you'll always be up to date.

You can keep in touch with standards developments and receive substantial discounts on the purchase price of standards, both in single copy and subscription format, by becoming a **BSI Subscribing Member**.

PLUS is an updating service exclusive to BSI Subscribing Members. You will automatically receive the latest hard copy of your standards when they're revised or replaced.

To find out more about becoming a BSI Subscribing Member and the benefits of membership, please visit bsigroup.com/shop.

With a **Multi-User Network Licence (MUNL)** you are able to host standards publications on your intranet. Licences can cover as few or as many users as you wish. With updates supplied as soon as they're available, you can be sure your documentation is current. For further information, email bsmusales@bsigroup.com.

BSI Group Headquarters

389 Chiswick High Road London W4 4AL UK

Revisions

Our British Standards and other publications are updated by amendment or revision.

We continually improve the quality of our products and services to benefit your business. If you find an inaccuracy or ambiguity within a British Standard or other BSI publication please inform the Knowledge Centre.

Copyright

All the data, software and documentation set out in all British Standards and other BSI publications are the property of and copyrighted by BSI, or some person or entity that owns copyright in the information used (such as the international standardization bodies) and has formally licensed such information to BSI for commercial publication and use. Except as permitted under the Copyright, Designs and Patents Act 1988 no extract may be reproduced, stored in a retrieval system or transmitted in any form or by any means – electronic, photocopying, recording or otherwise – without prior written permission from BSI. Details and advice can be obtained from the Copyright & Licensing Department.

Useful Contacts:

Customer Services

Tel: +44 845 086 9001

Email (orders): orders@bsigroup.com

Email (enquiries): cservices@bsigroup.com

Subscriptions

Tel: +44 845 086 9001

Email: subscriptions@bsigroup.com

Knowledge Centre

Tel: +44 20 8996 7004

Email: knowledgecentre@bsigroup.com

Copyright & Licensing

Tel: +44 20 8996 7070

Email: copyright@bsigroup.com