

High density recording format on CD-R/RW disc system — HD-BURN format

The European Standard EN 62403:2006 has the status of a
British Standard

ICS 35.220.30

National foreword

This British Standard is the official English language version of EN 62403:2006. It is identical with IEC 62403:2005.

The UK participation in its preparation was entrusted to Technical Committee EPL/100, Audio, video and multimedia systems and equipment, which has the responsibility to:

- aid enquirers to understand the text;
- present to the responsible international/European committee any enquiries on the interpretation, or proposals for change, and keep UK interests informed;
- monitor related international and European developments and promulgate them in the UK.

A list of organizations represented on this committee can be obtained on request to its secretary.

Cross-references

The British Standards which implement international or European publications referred to in this document may be found in the *BSI Catalogue* under the section entitled “International Standards Correspondence Index”, or by using the “Search” facility of the *BSI Electronic Catalogue* or of British Standards Online.

This publication does not purport to include all the necessary provisions of a contract. Users are responsible for its correct application.

Compliance with a British Standard does not of itself confer immunity from legal obligations.

Summary of pages

This document comprises a front cover, an inside front cover, the EN title page, pages 2 to 30, an inside back cover and a back cover.

The BSI copyright notice displayed in this document indicates when the document was last issued.

Amendments issued since publication

Amd. No.	Date	Comments

This British Standard was published under the authority of the Standards Policy and Strategy Committee on 31 May 2006

© BSI 2006

ISBN 0 580 48416 5

English version

**High density recording format on CD-R/RW disc system -
HD-BURN format
(IEC 62403:2005)**

Format d'enregistrement à haute densité
sur un système à disque CD-R/RW -
Format HD-BURN
(CEI 62403:2005)

Aufzeichnungsformat hoher Dichte
für CD-R/RW-Systeme -
HD-BURN-Format
(IEC 62403:2005)

This European Standard was approved by CENELEC on 2006-02-01. CENELEC members are bound to comply with the CEN/CENELEC Internal Regulations which stipulate the conditions for giving this European Standard the status of a national standard without any alteration.

Up-to-date lists and bibliographical references concerning such national standards may be obtained on application to the Central Secretariat or to any CENELEC member.

This European Standard exists in three official versions (English, French, German). A version in any other language made by translation under the responsibility of a CENELEC member into its own language and notified to the Central Secretariat has the same status as the official versions.

CENELEC members are the national electrotechnical committees of Austria, Belgium, Cyprus, the Czech Republic, Denmark, Estonia, Finland, France, Germany, Greece, Hungary, Iceland, Ireland, Italy, Latvia, Lithuania, Luxembourg, Malta, the Netherlands, Norway, Poland, Portugal, Romania, Slovakia, Slovenia, Spain, Sweden, Switzerland and the United Kingdom.

CENELEC

European Committee for Electrotechnical Standardization
Comité Européen de Normalisation Electrotechnique
Europäisches Komitee für Elektrotechnische Normung

Central Secretariat: rue de Stassart 35, B - 1050 Brussels

Foreword

The text of the International Standard IEC 62403:2005, prepared by technical area 7: Moderate data rate storage media, equipment and systems of IEC TC 100, Audio, video and multimedia systems and equipment, was submitted to the formal vote and was approved by CENELEC as EN 62403 on 2006-02-01 without any modification.

The following dates were fixed:

- latest date by which the EN has to be implemented at national level by publication of an identical national standard or by endorsement (dop) 2007-02-01
- latest date by which the national standards conflicting with the EN have to be withdrawn (dow) 2009-02-01

The International Electrotechnical Commission (IEC) and CENELEC draw attention to the fact that it is claimed that compliance with this document may involve the use of patents.

The IEC and CENELEC take no position concerning the evidence, validity and scope of this patent right.

The holder of this patent right has assured the IEC that he is willing to negotiate licences under reasonable and non-discriminatory terms and conditions with applicants throughout the world. In this respect, the statement of the holder of this patent right is registered with the IEC. Information may be obtained from:

Sanyo Electric Co., Ltd.
5-5 Keihan-hondori 2-chome Moriguchi City, Osaka, 570-8677, Japan

Attention is drawn to the possibility that some of the elements of this document may be the subject of patent rights other than those identified above. IEC and CENELEC shall not be held responsible for identifying any or all such patent rights.

Annex ZA has been added by CENELEC.

Endorsement notice

The text of the International Standard IEC 62403:2005 was approved by CENELEC as a European Standard without any modification.

CONTENTS

1	Scope	5
2	Normative references	5
3	Terms and definitions	6
4	Convention and notations	7
4.1	Representation of numbers	7
4.2	Names.....	8
5	List of acronyms	8
6	General requirements	9
6.1	Environment.....	9
6.2	Unrecorded disc	10
6.3	Recorded disc	10
7	Mechanical and physical characteristics	10
7.1	Mechanical parameters	10
7.2	Optical parameters	10
7.3	Recording parameters	10
8	Disc format.....	10
8.1	Track format.....	10
8.2	Data frame format	12
8.3	ECC block format	12
8.4	Recording frames	12
8.5	Physical sectors	12
8.6	Sector number.....	12
8.7	Format of the inner area	12
8.8	Format of the user data area	21
8.9	Format of the lead-out area	21
9	File system	21
Annex A (normative) A standard disc		22
Annex B (normative) ATIP synchronization rule		28
Annex C (normative) General linking rules (ATIP).....		29
Annex ZA (normative) Normative references to international publications with their corresponding European publications		30
Figure 1 – Track layout		11
Figure 2 – Sector structure		11
Figure 3 – PCA structure		12
Figure 4 – Lead-in (PMD) data structure		13
Figure 5 – Multi-session structure		13
Figure 6 – Lead-in (PMD) data structure		14
Figure A.1 – Read only optical pick up		22
Figure A.2 – Recorder optical pick up		23
Figure A.3 – Modulation amplitude and signal asymmetry		25
Figure A.4 – General system diagram for jitter measurement		25

Figure A.5 – Write strategy pulse	26
Figure A.6 – Write strategy pulse for CD-RW disc	27
Figure B.1 – ATIP synchronization rule	28
Figure C.1 – Write start for general linking rules (ATIP)	29
Figure C.2 – Write stop for general linking rules (ATIP)	29
Table 1 – PMA padding data format	13
Table 2 – TPMA structure-1	14
Table 3 – TPMA structure-2	14
Table 4 – TPMA structure-3	15
Table 5 – Initial data of PMD lead-in of disc information	15
Table 6 – Write type	16
Table 7 – Link size	16
Table 8 – PMD-1	17
Table 9 – PMD-1 item detail	18
Table 10 – PMD lead-in start address	18
Table 11 – Media information	19
Table 12 – Point field	19
Table 13 – PMD-2	19
Table 14 – PMD-3	20
Table 15 – PMD-4	20
Table 16 – PSI	20
Table 17 – PMD lead-in start address	21
Table 18 – Media information	21

HIGH DENSITY RECORDING FORMAT ON CD-R/RW DISC SYSTEMS – HD-BURN FORMAT

1 Scope

This International Standard specifies the HD-BURN format applied to CD-R/RW discs. The HD-BURN system is capable of recording the information in double density compared to the conventional CD-R/RW disc. It enables the realization of products with high reliability, high speed and interchangeability, and is especially suitable for consumer applications with high cost-performance.

This document describes:

- the physical characteristics for the recording and playback;
- the track structure of a disc;
- the data structure in the track;
- logical format structure.

2 Normative references

The following references are indispensable for the application of this document. For dated references, only the cited edition applies. For undated references, the latest edition of the referenced document (including any amendments) applies.

IEC 60908, *Audio recording – Compact disc digital audio system*

ISO/IEC 16448:2002, *Information technology – 120 mm DVD – Read-only disk*

ISO/IEC 20563, *Information technology – 80 mm (1,23 Gbytes per side) and 120 mm (3,95 Gbytes per side) DVD-recordable disc (DVD-R)*

IEC 62291:2002, *Multimedia data storage – Application program interface for UDF based file systems*

ISO 9660:1988, *Volume and file structure of CD-ROM for Information Interchange*

ISO/IEC 13346-1:1995, *Information technology – Volume and file structure of write-once and rewritable media using non-sequential recording for information interchange – Part 1: General*

The Red Book: *Compact disk digital Audio System Description Version*, May 1999
Sony/Philips

The Orange Book part2: *Recordable compact disk systems, Part2 CD-R Version 3.1*,
Sony/Philips

The Orange Book part 3: *Recordable compact disk system, Part3 CD-RW Volume 3, Ultra-Speed Ver 1.0*

NOTE The Red book and Orange book can be obtained from Sony/Philips.

3 Terms and definitions

For the purposes of this document, the following terms and definitions apply.

3.1

absolute time in pre-groove

ATIP

time-code information contained in the pre-groove with an additional modulation of the wobble

3.2

access guard area

AGA

preamble data area for reading the following ECC blocks

3.3

HD-BURN

high-density write system at CD-R/RW disc

3.4

land pre pit

LPP

pits embossed on the land during the manufacture of the disc substrate, which contain address information

3.5

multi-session

disc constituted by some sessions

3.6

non CD sector

sector, which has a different structure from the CD

3.7

physical sector number

PSN

serial number, which is allocated to physical sectors on the disc

3.8

pre-groove

guidance track in which clocking and time code information is stored by means of an FM modulated wobble

3.9

program memory data

PMD

information, which is described on the recording program of the disc, including information on each recording mode

3.10

program start information

PSI

start address of the first lead-in

3.11

Reed-Solomon product code

RSPC

method of an error correction code, which corrects errors by multiple bits

3.12

sector

smallest addressable part of a track in the information zone of a disc that can be accessed independently of other addressable parts

3.13

session

area on the disc consisting of lead-in area, program area and lead-out area

3.14

synchronization frame

group of 1488 channel bits, which is representing a synchronization pattern

3.15

temporary program memory area

TPMA

area, which is used for intermediate storage

3.16

track

path, which is followed by the focus of the optical beam during one revolution of the disc

4 Convention and notations

4.1 Representation of numbers

A measured value is rounded off to the least significant digit of the corresponding specified value. It implies that a specified value of 1,26 with a positive tolerance of +0,01, and a negative tolerance of –0,02 allows a range of measured values from 1,235 to 1,275.

- Letters and digits in parentheses represent numbers in hexadecimal notation.
- The setting of a bit is denoted by ZERO or ONE.
- Numbers in binary notation and bit combinations are represented by strings of 0 and 1.
- Numbers in binary notation and bit combinations are shown with the most significant bit to the left.
- Negative values of numbers in binary notation are given in Two's complement.
- In each field the data is recorded so that the most significant byte (byte 0) is recorded first. Within each byte the least significant bit is numbered 0 and is recorded first, the most significant bit (numbered 7 in an 8-bit byte) is recorded last. This order of recording applies also to the data input of the error detection and correction circuits and to their output.

4.2 Names

The names of entities, for example specific tracks, fields, etc., are given with a capital letter.

5 List of acronyms

ADB	Address Data Bit
ALPC	Auto Laser Power Control
ASYM	Asymmetry
BCD	Binary Coded Decimal
BP	Byte Position
BPF	Band Pass Filter
CD-R	Compact Disk Recordable
CD-RW	Compact Disk ReWritable
CDS	Codeword Digital Sum
CD-WO	Compact Disk Write Once
CLV	Constant Linear Velocity
CRC	Cyclic Redundancy Check
DCB	Data Channel Bit
DSV	Digital Sum Value
DVD	Digital Versatile Disc
ECC	Error Correction Code
EDC	Error Detection Code
HDB	High Density Burn (= HD-BURN)
HF	High Frequency
ID	Identification Data
IED	ID Error Detection code
LOS	Lead-out Start Address
LPF	Low-Pass Filter
LSB	Least Significant Byte
MSB	Most Significant Byte
NRZI	Non Return to Zero Inverted
OPC	Optimum Power Control
PAD	Padding
PCA	Power Calibration Area
PI	Parity of Inner-code
PMA	Program Memory Area
PO	Parity of Outer-code
PUH	Pick Up Head
R/W	Rewritable
RID	Recorder Identifier
RS	Reed-Solomon

6 General requirements

6.1 Environment

6.1.1 Testing environment

The test environment is the environment where the air immediately surrounding the disc has the following properties.

	For dimensional measurements	For other measurements
temperature:	23 °C ± 2 °C	15 °C ± 35 °C
relative humidity:	45 % to 55 %	45 % to 75 %
atmospheric pressure:	60 kPa to 106 kPa	60 kPa to 106 kPa

Unless otherwise stated, all tests and measurements shall be made in this test environment.

6.1.2 Operating environment

6.1.2.1 Recorded and unrecorded discs

This International Standard requires that an optical disc which meets all mandatory requirements of this International Standard in the specified test environment provides data interchange over the specified ranges of environmental parameters in the operating environment.

Discs used for data interchange shall be operated under the following conditions, when mounted in the drive supplied with voltage and measured on the outside surface of the disc. The disc exposed to storage conditions shall be conditioned in the operating environment for at least 2 h before operating.

temperature:	–25 °C to 70 °C
relative humidity:	3 % to 95 %
absolute humidity:	0,5 g/m ³ to 60,0 g/m ³
temperature gradient:	15 °C/h maximum
relative humidity gradient:	10 %/h maximum

There shall be no condensation of moisture on the disc.

6.1.2.2 Unrecorded disc environmental conditions during recording

The disc exposed to storage conditions shall be conditioned in the recording environment for at least 2 h before operating.

temperature:	–5 °C to 55 °C
relative humidity:	10 % to 95 %
absolute humidity:	0,5 g/m ³ to 30,0 g/m ³

There shall be no condensation of moisture on the disc.

6.1.2.3 Conditions of measurement

Measurements and mechanical checks shall be carried out within the following limits unless otherwise specified:

ambient temperature:	15 °C to 35 °C
relative humidity:	45 % to 75 %
air pressure:	86 kPa to 106 kPa

6.2 Unrecorded disc

6.2.1 Unrecorded CD-R disc

Unrecorded CD-R disc fulfils the requirements as written in the Disc Specification of the Orange Book, part 2.

6.2.2 Unrecorded CD-RW disc

Unrecorded CD-RW disc fulfils the requirements as written in the Disc Specification of the Orange Book, part 3.

6.3 Recorded disc

6.3.1 Recorded CD-R disc

Recorded CD-R disc fulfils the requirements as written in the Disc Specification of the Orange Book, part 2.

6.3.2 Recorded CD-RW disc

Recorded CD-RW disc fulfils the requirements as written in the Disc Specification of the Orange Book, part 3.

7 Mechanical and physical characteristics

7.1 Mechanical parameters

Refer to IEC 60908, Clause 5: Mechanical parameters

7.2 Optical parameters

Refer to IEC 60908, Clause 6: Optical parameters

7.3 Recording parameters

Refer to IEC 60908, Clause 7: Recording parameters

8 Disc format

8.1 Track format

8.1.1 General description of track format

The track structure of CD-R/RW disc and HD-BURN disc is shown in the Figure 1.

Example disc [Type80 (LOS)] for single session structure:

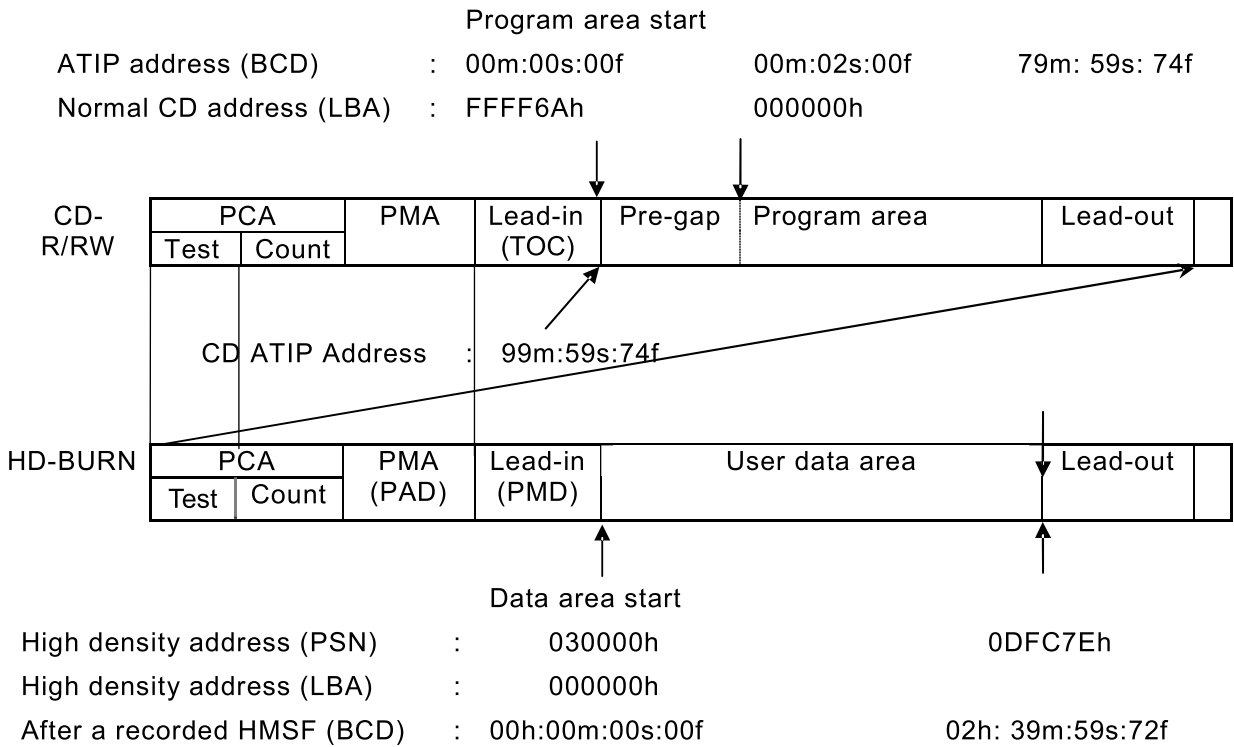

IEC 826/05

PMD start address can be read from ATIP information.

Figure 1 – Track layout

Lead-in and lead-out of the number, which is equal to the number of sessions, exist in the disc in case of the multisession structure.

8.1.2 HD-BURN sector allocation

Relations among CD-R/RW ATIP, HD-BURN physical sector and one ECC block are shown in Figure 2.

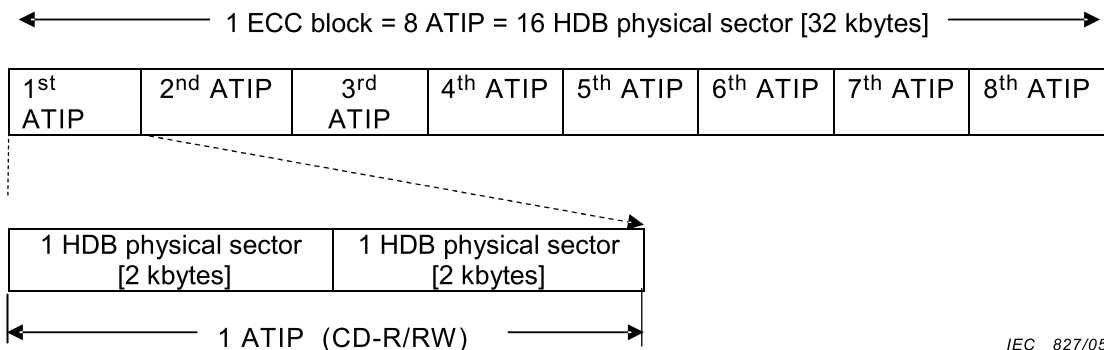

IEC 827/05

Figure 2 – Sector structure

8.2 Data frame format

Refer to ISO/IEC 16448, Clause 16.

8.3 ECC block format

Refer to ISO/IEC 16448, Clause 18.

8.4 Recording frames

Refer to ISO/IEC 16448, Clause 19.

8.5 Physical sectors

Refer to ISO/IEC 16448, Clause 21.

8.6 Sector number

Refer to ISO/IEC 16448, Clause 25.

8.7 Format of the inner area

8.7.1 Format of the PCA

PCA (CD-R, RW media) should be handled as below.

Use the PCA of CD-R/RW as a PCA of the HD-BURN disc.

PCA for disc shall be used for OPC as well as CD writing. (See Figure 3.)

Most inner side	PCA		PMA (PAD)
	Test area	Count area	

IEC 828/05

Figure 3 – PCA structure

Test area has 1 500 ATIP capacity.
(Refer to Orange Book, part 2 and part 3.)

1 500 ATIP allows 187 ECC Block to be included.

In the case of testing per 1 ECC, test is possible to be done up to 187 times.

8.7.2 Format of the PMA

PMA shall be padded with data as shown in Table 1 and the recording sector shall be ECC block (32KB).

In case of the non-formatted PMA, the HD-BURN drive does not handle as a HD-BURN disc.

NOTE In the case of the PMA filled with non CD sector, a usual CD-R/RW record device judges this disc as an incompatible medium.

Table 1 – PMA padding data format

PMA padding data			
BP	Contents	Form	Byte
00 ~ 31	Drive manufacturer ID	ASCII	32
32 ~ 39	Reserved	00	8
40 ~ 55	Model number	ASCII	16
56 ~ 63	Reserved	00	8
64 ~ 79	Serial number	ASCII	16
80 ~ 87	Reserved	00	8
88 ~ 103	Unique disc ID	->	16
104 ~ 111	Reserved	00	8
112 ~ 127	HD-BURN	Hexadecimal	1x16
128 ~2047	Reserved	00	1 920

BP	Contents	Form
2	Reserved	00
4	Year	ASCII
2	Month	ASCII
2	Date	ASCII
2	Time	ASCII
2	Minute	ASCII
2	Second	ASCII

Unique disc ID	
Value	Contents
00h	Reserved
01h	2x
Other	Reserved

HD-BURN

8.7.3 Format of the lead-in (PMD)

8.7.3.1 General

The data structure of the lead-in (PMD) for the first session is shown in the Figure 4.

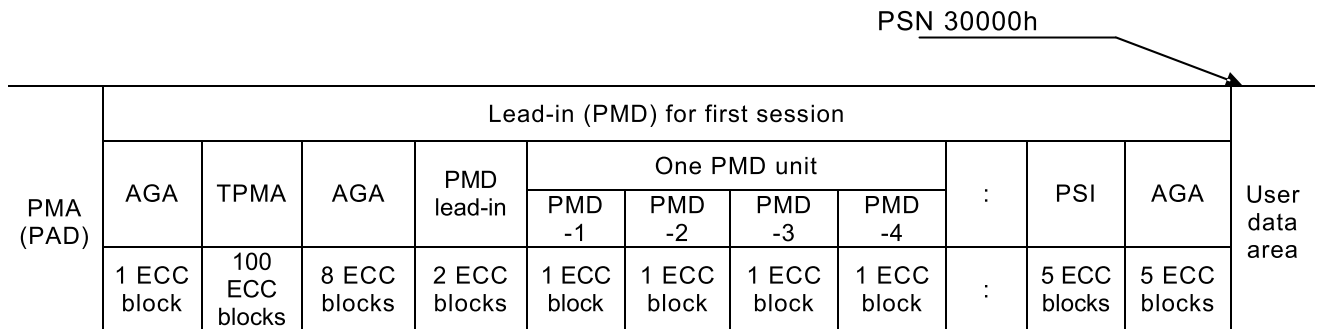

IEC 829/05

Figure 4 – Lead-in (PMD) data structure

PMD shall be written when session is closed. The information about track written to data area shall be generated by each PMA data of TPMA.

Lead-in (PMD) should be specified by the following conditions;

- TPMA exists only in the first lead-in
- Each of PMD-1 ~ PMD-4 consists of one ECC block.

8.7.3.2 Multi-session

The multi-session structure in the HD-BURN writing is shown in the figure 5.

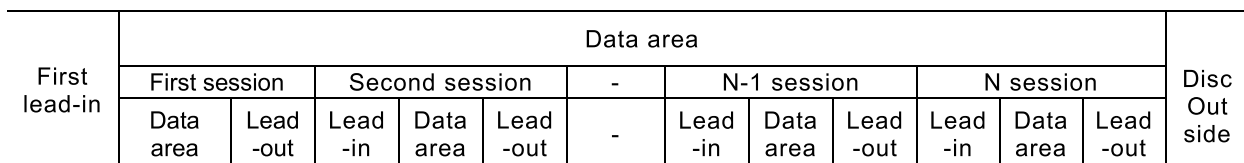

Figure 5 – Multi-session structure

IEC 830/05

The structure of the second session and after is shown in the Figure 6.

Previous session	Lead-in (PMD) for second session and after									Next session or next writable area
	AGA	PMD lead-in	One PMD unit				:	PSI	AGA	
			PMD -1	PMD- 2	PMD- 3	PMD- 4				
8 ECC blocks	2 ECC blocks	1 ECC block	1 ECC block	1 ECC block	1 ECC block	:	5 ECC blocks	5 ECC blocks		

Figure 6 – Lead-in (PMD) data structure

IEC 831/05

TPMA doesn't exist from the second session and after.

TPMA of the first session shall be used as TPMA of the second session and after.

PMD shall be written when session is closed. The information about track written to data area shall be generated by each PMA data of TPMA.

8.7.3.3 TPMA structure

TPMA is an area where each track information is temporally stored.

For DAO recording, TPMA shall be padded with 00h.

For TAO or incremental recording, TPMA is recorded at each completion or reservation of one data track.

A TPMA data shall be recorded by one ECC block (32 kbytes).

Table 2 – TPMA structure-1

AGA	TPMA					AGA	PMD lead-in
	PMA01	PMA02	:	PMA99	PMA100		
	1 ECC block	1 ECC block	:	1 ECC block	1 ECC block		

Table 3 – TPMA structure-2

PMA01~PMA100				
BP	Contents	Form	Byte	Detail
00 ~ 07	PMD number	Hexadecimal	1x8	10h
08 ~ 15	Marking	ASCII	1x8	HD-BURN
16 ~ 23	Reserved	00h	1x8	
24 ~ 35	Item 1	See structure-3	12	1 item + 1 byte
36 ~ 41	Reserved	00h	6	
42 ~ 53	Item 2	See structure-3	12	1 item + 1 byte
54 ~ 59	Reserved	00h	6	
60 ~ 71	Item 3	See structure-3	12	1 item + 1 byte
72 ~ 77	Reserved	00h	6	
78 ~ 89	Item 4	See structure-3	12	1 item + 1 byte
90 ~ 2047	Reserved	00h	1 958	

Table 4 – TPMA structure-3

	1 byte	1 byte	1 byte	1 byte	1 byte	1 byte	1 byte	1 byte	1 byte	1 byte	1 byte	1 byte
Item No	SessionNo	Control/ADR		TNO	Point	Min	Sec	Frame	Hour	Pmin	Psec	Pframe
1	Total N	4	1	00	D0	Number of total tracks			Next TPMA PSN address			
2	Current N	4	1	00	N	Stop time of track			Start time of track			
3	Current N	4	1	00	Last TNO	FF	FF	FF		Start time of lead-out		
4	Current N	4	2	00	Reserved	Disc identification				Reserved	Disc type	Reserved

The hatching field shall be converted to hexadecimal data by the drive if the disc contains a value between 0 and 99BCD.

D0 pointer: One D0 exists in each session.

8.7.3.4 PMD lead-in structure

The disc information of current session is recorded in PMD lead-in.

Table 5 – Initial data of PMD lead-in of disc information

PMD lead-in				
BP	Contents	Form	Byte	Detail
00 ~ 07	PMD number	Hexadecimal	1x8	10h
08 ~ 15	Marking	ASCII	1x8	HD-BURN
16 ~ 23	Reserved	00h	1x8	
24 ~ 31	Write type	Hexadecimal	1x8	DAO or TAO or incremental
32 ~ 39	Reserved	00h	8	
40 ~ 55	Link size	Hexadecimal	1x16	Zero-link or 32 KB-link
56 ~ 63	Reserved	00h	8	
64 ~ 79	Next session start address 1	Hexadecimal	4x4	PSN
80 ~ 87	Reserved	00h	8	
88 ~ 103	Next session start address 2	Hexadecimal	4x4	LBN (optional)
104 ~ 111	Reserved	00h	8	
112 ~ 127	Next session start address 3	BCD	4x4	HMSF (optional)
128 ~ 2047	Reserved	00h	1 920	

Next session address 1(PSN): 00 00 00 00h ~ FF FF FF FFh
 Next session address 2(LBN): 00 00 00 00h ~ FF FF FF FFh
 Next session address 3(HMSF): 00h00m00s00f ~ 09h59m59s74f

Table 6 – Write type

Value	Write type
00h	DAO-CD
01h	TAO-CD
02h	Incremental-CD
10h	SAO(DAO)-DVD
11h	Reserved
12h	Incremental-DVD
Other	Reserved

Table 7 – Link size

Value	Link size
00h	Zero-link
01h	32 KB-link
Other	Reserved

PMD lead-in shall be recorded with only two ECC blocks.

The entire capacity of PMD varies from one medium vender to another since PMD uses lead-in on the CD-R/RW media.

EXAMPLE

In the case of lead-in start address closest to program area address, the lead-in capacity is in the range of 97m50s00f ~ 99m59s74f and approximately 130 s.

In the above case, converted ATIP sector number 9 750 calculated by $130 \text{ s} \times 75 \text{ frames}$.

In the case of applying this status to the HD-BURN recording, available minimum lead-in capacity is as follows;

$9\,750 \text{ sectors} / 8 \text{ ATIP sectors} = 1\,218 \text{ ECC blocks}$, where all digits below the decimal point are dropped.

The capacity in the lead-in area varies in each disc model.

The above case shows a minimum capacity example.

8.7.3.5 PMD-1

PMD-1 is current session information.

TOC data are recorded in PMD-1.

Table 8 – PMD-1

PMD-1(current session information)				
BP	Contents	Form	Byte	Detail
00 ~ 07	PMD number	Hexadecimal	1x8	11h
08 ~ 15	Marking	ASCII	1x8	HD-BURN
16 ~ 19	Reserved	00h	4	
20 ~ 31	Item-01	See Table 9	12	"1 item of Table 9" + 1 byte"
32 ~ 35	Reserved	00h	4	
36 ~ 47	Item-02	See Table 9	12	"1 item of Table 9" + 1 byte"
48 ~ 51	Reserved	00h	4	
52 ~ 63	Item-03	See Table 9	12	"1 item of Table 9" + 1 byte"
64 ~ 67	Reserved	00h	4	
68 ~ 79	Item-04	See Table 9	12	"1 item of Table 9" + 1 byte"
80 ~ 83	Reserved	00h	4	
84 ~ 95	Item-05	See Table 9	12	"1 item of Table 9" + 1 byte"
96 ~ 99	Reserved	00h	4	
100 ~ 111	Item-06	See Table 9	12	"1 item of Table 9" + 1 byte"
112 ~ 115	Reserved	00h	4	
116 ~ 127	Item-07	See Table 9	12	"1 item of Table 9" + 1 byte"
127 ~ 135	Reserved	00h	8	
136 ~ 143	PMD lead-in start address	Hexadecimal	8	
144 ~ 197	Media information	See Table 10	54	
198 ~ 2047	Reserved	00h	1 848	

Table 9 – PMD-1 item detail

Item No	SES-NO	CONT	ADR	TNO	Point	Min	Sec	Frame	Hour	PHour	PMin	PSec	Pframe
	1 byte	4bit	4bit	1 byte	1 byte	1 byte	1 byte	1 byte	4bit	4bit	1 byte	1 byte	1 byte
	0	1		2	3	4	5	6	7		8	9	10
1	N	4	1	00	01-63	ATIME (absolute time)			Start position of track				
2	N	4	1	00	A0	ATIME (absolute time)			00	00	First Track number	00	
3	N	4	1	00	A1	ATIME (absolute time)			00	00	Last Track number	00	
4	N	4	1	00	A2	ATIME (absolute time)			Start position of lead-out				
5	N	4	5	00	B0	Start time of next possible program in the recordable area of multi-session disc or F:FF:FF:FF			Maximum start time of outer-most lead-out area in the recordable area of multi-session disc				
6	N	4	5	00	C0	Copy of special information in ATIP		# of pointers in mode 5	Start time of the first lead-in area of the multi-session disc				
7	N	4	5	00	C1	Copy of additional information in ATIP		0000b	Set to 00h				

The hatching field shall be converted to hexadecimal data by the drive if the disc contains a value between 0 and 99BCD.

The session number field is shown in hexadecimal.

The non-hatching field shows raw data. It shall not be converted to hexadecimal by the drive.

Table 10 – PMD lead-in start address

PMD lead-in start address	8 bytes	Hexadecimal	PSN	
---------------------------	---------	-------------	-----	--

The value set to this field is limited to 00h or 02xxxxh.

The address is fixed to 029E60h when 00h is set to field.

Table 11 – Media information

Field name		Order		Description	Notice
Media type	2 bytes	Hexadecimal	00h	Read only media	Mandatory
			01h	Recordable media	
			02h	Rewritable media	
Recording density	2 bytes	Hexadecimal	00h	2x	Mandatory
			Other	Reserved	
Media name	32 bytes	ASCII		Reserved	Optional
Media version	16 bytes	Hexadecimal		Reserved	Optional
Data type	2 bytes	Hexadecimal	00h	Data	Optional
			01h	Audio	

Table 12 – Point field

ADR	Point	Description
1	01-63	Track number
1	A0	First track number in the current session
1	A1	Last track number in the current session
1	A2	Start location of the lead-out (current session)
5	B0	The start time for the next possible session's program area.
5	C0	Start time of the first lead-in area of the multi-session disc (only 1 st session)
5	C1	Copy of additional information1 in ATIP

8.7.3.6 PMD-2

PMD-2 is an area to record copy protection information. In the future, when this information is necessary, the value of reserved contents shall be assigned.

Table 13 – PMD-2

PMD-2 (copy protection information)				
BP	Contents	Form	Byte	Detail
00 ~ 07	PMD number	Hexadecimal	8	12h
08 ~ 15	Marking	ASCII	8	HD-BURN
16 ~ 2047	Reserved	00h	2 040	

8.7.3.7 PMD-3

PMD-3 is an area to record write strategy and over write information. This information should be unique to each manufacturer.

Table 14 – PMD-3

PMD-3 (write strategy and overwrite information)				
BP	Contents	Form	Byte	Detail
00 ~ 07	PMD number	Hexadecimal	8	13h
08 ~ 15	Marking	ASCII	8	HD-BURN
16 ~ 2047	Reserved	00h	2 040	Vendor unique

8.7.3.8 PMD-4

PMD-4 is an area to record OPC history information.

Table 15 – PMD-4

PMD-4 (OPC history information)				
BP	Contents	Form	Byte	Detail
00 ~ 07	PMD number	Hexadecimal	8	14h
08 ~ 15	Marking	ASCII	8	HD-BURN
16 ~ 23	RID	Hexadecimal	8	Unique serial number
24 ~ 31	Reserved	00h	8	
32 ~ 159	OPC history	Hexadecimal	128	
160 ~ 2047	Reserved	00h	1 888	

In the case of CD-RW media, overwrite on the recorded portion is possible.

In the case of implementation of overwrite, the information of PMA and PMD should be rewritten, if it is necessary. However, the overwrite is applicable only for DAO recording and TAO recording, and should not be applied to any other types of recording.

8.7.3.9 PSI structure format

PSI is an area to record PMD start information.

This information should be recorded to the fixed address in every disc model because the first lead-in start address is different for each disc.

Table 16 – PSI

PSI (PMD start information)				
BP	Contents	Form	Byte	Detail
00 ~ 07	RRI ID	Hexadecimal	1x8	20h
08 ~ 15	Marking	ASCII	1x8	HD-BURN
16 ~ 23	Reserved	00h	8	
24 ~ 31	PMD lead-in start address	Hexadecimal	8	
32 ~ 87	Media information	See Table-18	56	
88 ~ 2047	Reserved	00h		

Table 17 – PMD lead-in start address

PMD lead-in start address	8 bytes	Hexadecimal	PSN	
----------------------------------	---------	-------------	-----	--

The value set to this field is limited to 00h or 02xxxxh.
Address is fixed to 029E60h when 00h is set to this field.

Table 18 – Media information

Field name		Order		Description	Notice
Media type	2 bytes	Hexadecimal	00h	Read only media	Mandatory
			01h	Recordable media	
			02h	Rewritable media	
Recording density	2 bytes	Hexadecimal	00h	2x	Mandatory
			Other	Reserved	
Media name	32 bytes	ASCII		Reserved	Optional
Media version	16 bytes	Hexadecimal		Reserved	Optional
Data type	2 bytes	Hexadecimal	00h	Data	Optional
			01h	Audio	

8.8 Format of the user data area

See Figure 1 for start address of program area.

The position of PSN 030000h is the same position as that of 00minutes/00seconds/00frame.
A minimum record unit is one ECC block.

8.9 Format of the lead-out area

For the physical sector in the lead-out area, the attribute of the lead-out area shall be set in area type, which exists in the sector information.
The main-data of lead-out shall be recorded to 00h.

Calculate the size based on ATIP sector:

- 1 First session: For 90 s -> (90 s x 75 frames x 2) + 4 frames
= HD-BURN lead-out capacity
- 2 Second session and afterwards: For 30 s -> (30 s x 75 frames x 2) + 12 frames
= HD-BURN lead-out capacity

NOTE Lead-out exists in each session. The lead-out size of the first session is different from that of the second session and afterwards.

The lead-out structure is the same as that of CD/DVD's lead-out structure.

9 File system

The file system should be based on the following standards;

IEC 62291: 2002, ISO 9660:1988 and ISO/IEC 13346-1:1995.

Annex A (normative)

A standard disc

A.1 PUH

A.1.1 PUH for measuring recorded disc and read only disc

Figure A.1 shows the optical system of PUH, which is used for the performance evaluation of the recorded disc and the read-only disc.

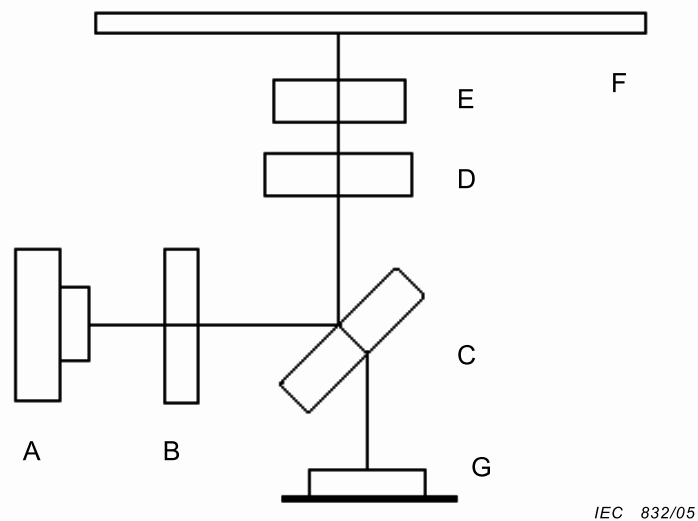

Key

A	Laser diode	B	Grating lens
C	Half-mirror	D	Collimator lens
E	Objective lens	F	Optical disc
G	Split photodiode		

Figure A.1 – Read only optical pick up

The parameter of the optical system is indicated as follows:

a) Wavelength (λ):	780 nm \pm 10 nm
b) Polarization:	Perpendicular to the track
c) Wavefront distortion:	< 0,05 λ (RMS value)
d) Numerical aperture:	0,47 \pm 0,01
e) Rim intensities	
Tangential:	> 0,3
Radial:	> 0,3
f) Laser power	
Reading:	< 0,7 mW (continuous wave in the central spot)

A.1.2 PUH for recording

Figure A.2 shows the optical system of PUH, which is used for the writing performance evaluation.

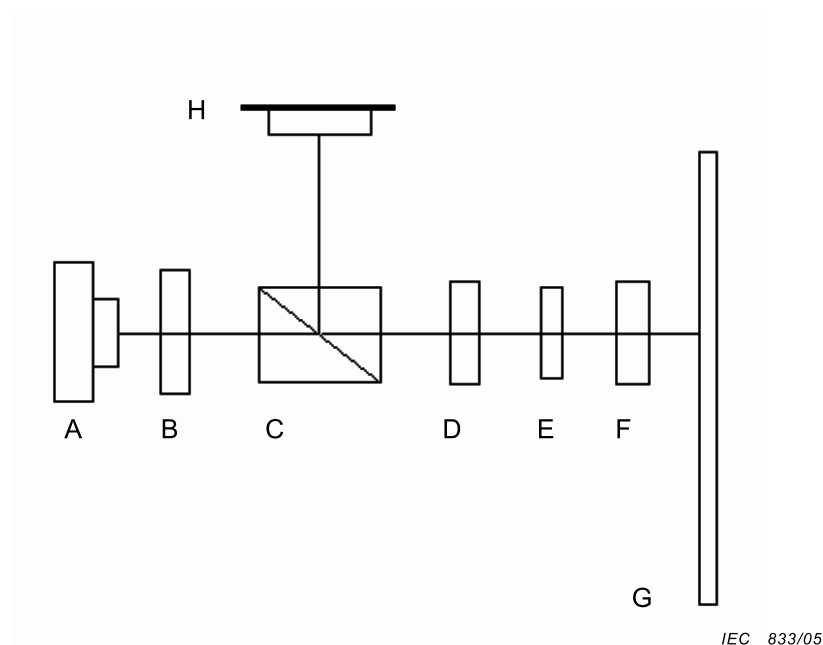

Key

A	Laser diode	B	Grating lens
C	Polarizing beam splitter	D	Collimator lens
E	Optical quarter-wave plate	F	Objective lens
G	Optical disc	H	Split photodiode

Figure A.2 – Recorder optical pick up

The parameter of the optical system is indicated as follows:

- a) Wavelength (λ): 785 nm \pm 5 nm
- b) Polarization: Circular
- c) Wavefront distortion: < 0,05 λ (RMS value)
- d) Numerical aperture: 0,50 \pm 0,01
- e) Rim intensities
 - Tangential: 0,3
 - Radial: 0,3
- f) Laser power
 - Reading: < 0,7 mW (continuous wave in the central spot)
 - Writing: According to the write strategy, see Figure A.2.

A.2 Operational signals for recorded disc and read only disc

A.2.1 Measurement conditions

The scanning velocity should be 4,51 times that of the CD.

The measurement conditions shall be as specified in 6.1.1.

The HF signal equalizing for jitter measurement shall be as specified in ISO/IEC 20563 Annex F.

A.2.2 Read conditions

The power of the read spot shall not exceed 1,0 mW (continuous wave in the central spot).

A.2.3 Recorded disc HF signals

Refer to ISO/IEC 20563, 13.3.

A.2.3.1 Modulation

The peak-to-peak value generated by the longest recorded mark and space is I_{14} .

The peak value corresponding to the HF signal before high-pass filtering is I_{14H} .

The peak-to-peak value generated by the shortest recorded mark and space is I_3 .

The zero level is the signal level obtained when no disc is inserted.

These parameters shall satisfy the following requirements:

$$I_{14}/I_{14H} = 0,60 \text{ minimum,}$$

$$I_3/I_{14} = 0,15 \text{ minimum.}$$

A.2.3.2 Signal asymmetry

The value of asymmetry shall satisfy the following requirements when a DVD-R disc is recorded at the optimum recording power P_0 . (See Figure A.3.)

$$-0,05 < ((I_{14H} + I_{14L})/2 - (I_{3H} + I_{3L})/2)/I_{14} < 0,15,$$

where

$(I_{14H} + I_{14L})/2$ is the centre level of I_{14} ,

$(I_{3H} + I_{3L})/2$ is the centre level of I_3 .

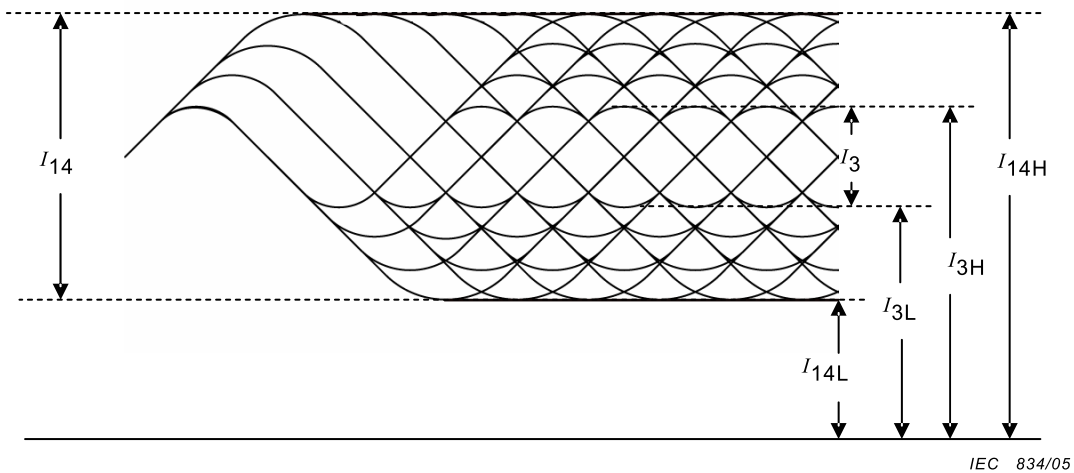

IEC 834/05

Figure A.3 – Modulation amplitude and signal asymmetry

A.2.3.3 Cross-track signal

Refer to ISO/IEC 20563, 13.3.3

A.2.4 Quality of signals

A.2.4.1 Jitter

Refer to ISO/IEC 20563, 13.4.1.

Jitter shall be less than 10,0 % of the channel bit clock period, when measured according to Figure A.4.

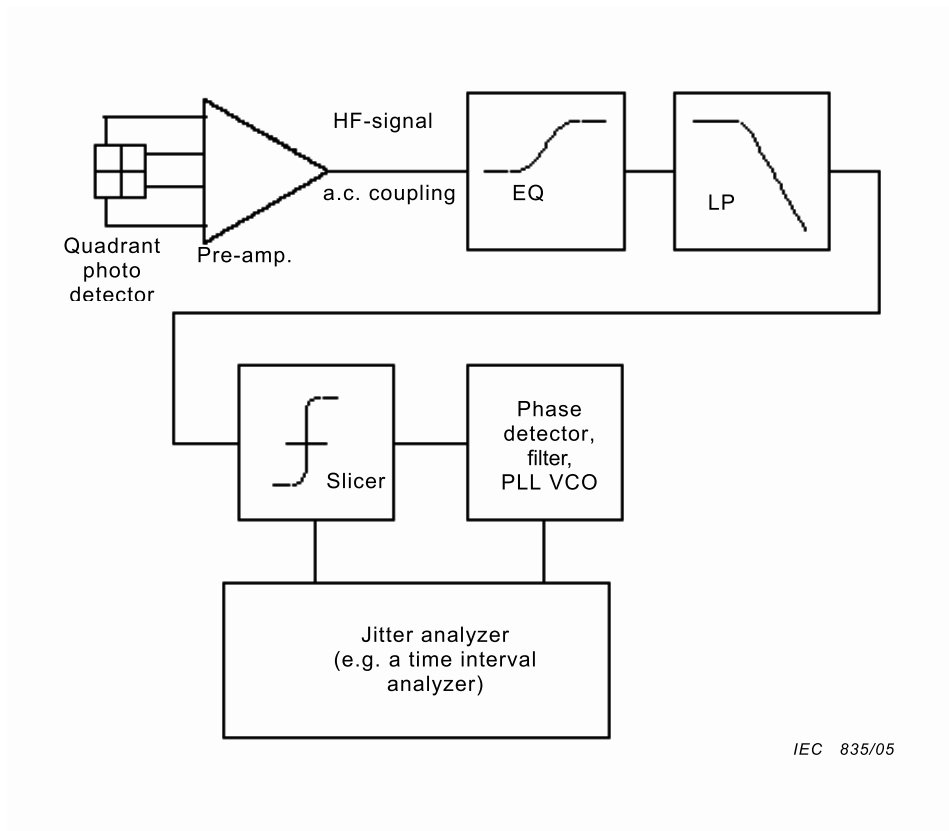

IEC 835/05

Figure A.4 – General system diagram for jitter measurement

A.2.4.2 Random errors

Refer to ISO/IEC 20563, 13.4.2.

A.2.4.3 Defects

Refer to ISO/IEC 20563, 13.4.3.

A.3 Write strategy for CD-R media testing

In the case of recording by this optical system indicated in Clause A.1 and Clause A.2, the write strategy pulse should be referred to Figure A.5.

NOTE Unstable optical power will influence the degree of modulation and jitter.

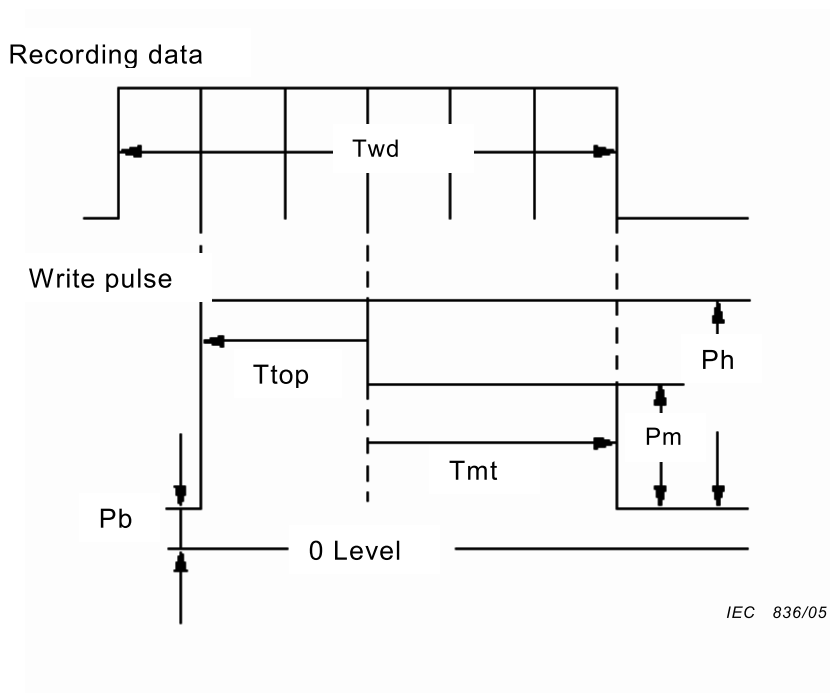

Figure A.5 – Write strategy pulse

Twd:	Recording signal width
Pb:	Playback power
Pm:	Write power
Ph:	Enhanced power
Pm+Pb:	Optimum recording power 5 mW ~ 10 mW at 3,57 m/s
Ttop:	2 T when Twd = 3 T, 5 T ~ 11 T and 14 T. (2 – 1/20) T when Twd= 4 T.
Tmt:	(N – 3) T
Ph/Pm:	1,08

A.4 Write strategy for CD-RW media testing

Example of the write pulse for CD-RW disc.

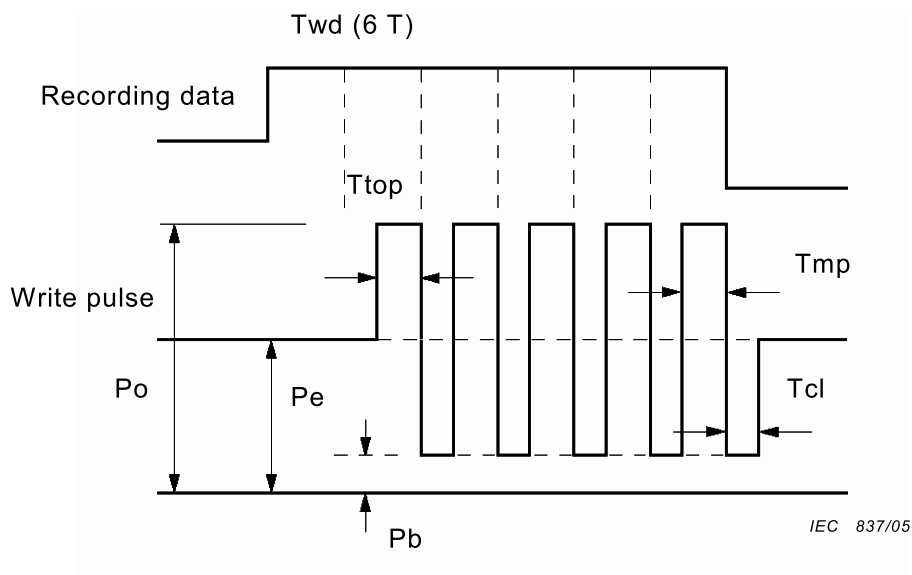

Figure A.6 – Write strategy pulse for CD-RW disc

Po:	Write power 7 ~ 19 mW at 3,57 m/s
Pe:	Erase power 3,5 ~ 7,5 mW at 3,57 m/s
Pb:	Playback power
Pe/Po:	0,43
Ttop:	0,5 T
Tmp:	0,5 T
Tcl:	0,2 T

Annex B
(normative)**ATIP synchronization rule**

Over the entire disc, the position between the ATIP synchronization and the ECC synchronization should be 0 ± 2 synchronization frames.

The position of ATIP synchronization is defined as the position where synchronization can be recognized as a synchronization pattern from the reproduced signal; this position appears directly after the physical synchronization patterns on the disc.

The position of a synchronization frame is defined as the start position of the physical synchronization pattern on the disc. (See Figure B.1.)

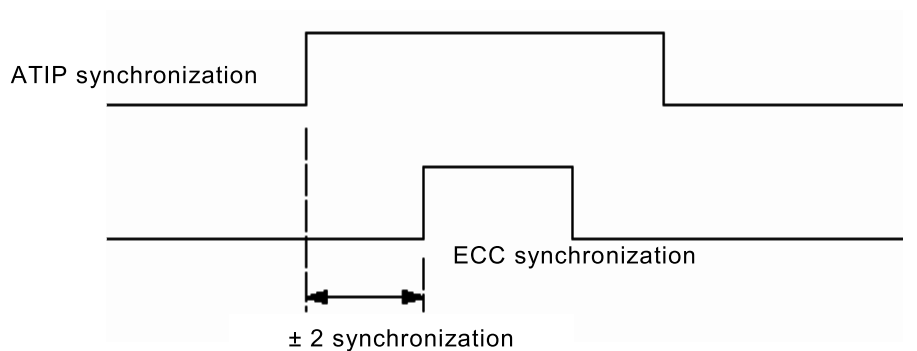

IEC 838/05

Figure B.1 – ATIP synchronization rule

Annex C
(normative)

General linking rules (ATIP)

The link position is the physical location on the disc where the recording of modulation signals is allowed to start and stop.

The nominal link position should be $30 T \pm 10 T$ from the changing point in the first $14 T/4 T$ pattern of ECC synchronization.

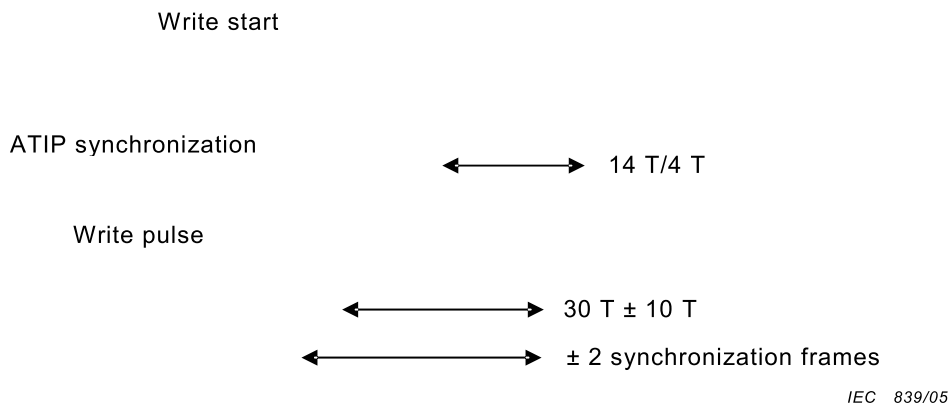
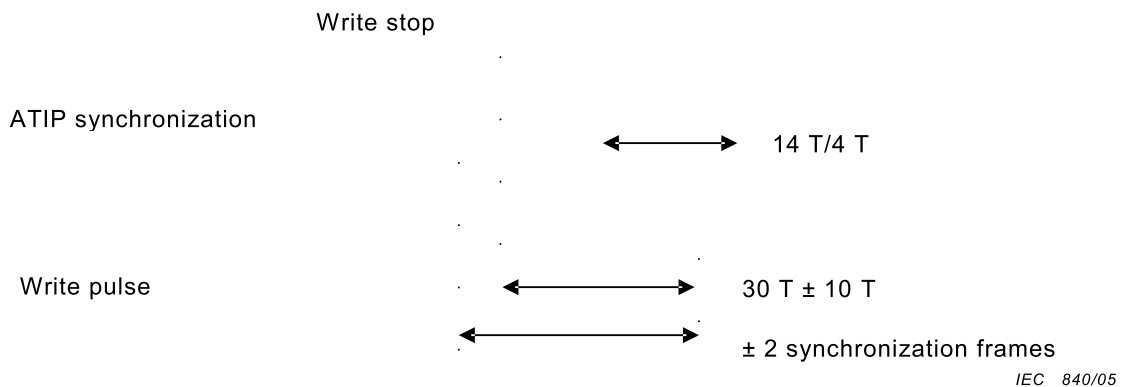

Figure C.1 – Write start for general linking rules (ATIP)

On the start point of record, the timing of $14 T$ of ECC block pattern of ATIP signal and a record signal serves as ± 2 synchronization frames.



NOTE The broken line indicates the waveform of write pulse, which is assumed to occur under continuous writing status. The drawing shows the timing.

Figure C.2 – Write stop for general linking rules (ATIP)

On the stop point of record, the timing between the changing point in the expected $14 T/4 T$ pattern if recording is continued and the ATIP synchronization point should be $30 T \pm 10 T$.

Annex ZA (normative)

Normative references to international publications with their corresponding European publications

The following referenced documents are indispensable for the application of this document. For dated references, only the edition cited applies. For undated references, the latest edition of the referenced document (including any amendments) applies.

NOTE Where an international publication has been modified by common modifications, indicated by (mod), the relevant EN/HD applies.

<u>Publication</u>	<u>Year</u>	<u>Title</u>	<u>EN/HD</u>	<u>Year</u>
IEC 60908	- ¹⁾	Audio recording - Compact disc digital audio system	EN 60908	1999 ²⁾
ISO/IEC 16448	2002	Information technology - 120 mm DVD - Read-only disk	-	-
ISO/IEC 20563	- ¹⁾	Information technology - 80 mm (1,23 Gbytes per side) and 120 mm (3,95 Gbytes per side) DVD-recordable disk (DVD-R)	-	-
IEC/TR 62291	2002	Multimedia data storage - Application program interface for UDF based file systems	-	-
ISO 9660	1988	Information processing - Volume and file structure of CD-ROM for information interchange	-	-
ISO/IEC 13346-1	1995	Information technology - Volume and file structure of write-once and rewritable media using non-sequential recording for information interchange Part 1: General	-	-
The Sony/Philips Red Book	1999	Compact disk digital audio system description	-	-
The Sony/Philips Orange Book	- ¹⁾	Recordable compact disk system - Part 2: CD-R	-	-
The Sony/Philips Orange Book	- ¹⁾	Recordable compact disk system - Part 3: CD-RW	-	-

¹⁾ Undated reference.

²⁾ Valid edition at date of issue.

BSI — British Standards Institution

BSI is the independent national body responsible for preparing British Standards. It presents the UK view on standards in Europe and at the international level. It is incorporated by Royal Charter.

Revisions

British Standards are updated by amendment or revision. Users of British Standards should make sure that they possess the latest amendments or editions.

It is the constant aim of BSI to improve the quality of our products and services. We would be grateful if anyone finding an inaccuracy or ambiguity while using this British Standard would inform the Secretary of the technical committee responsible, the identity of which can be found on the inside front cover. Tel: +44 (0)20 8996 9000. Fax: +44 (0)20 8996 7400.

BSI offers members an individual updating service called PLUS which ensures that subscribers automatically receive the latest editions of standards.

Buying standards

Orders for all BSI, international and foreign standards publications should be addressed to Customer Services. Tel: +44 (0)20 8996 9001. Fax: +44 (0)20 8996 7001. Email: orders@bsi-global.com. Standards are also available from the BSI website at <http://www.bsi-global.com>.

In response to orders for international standards, it is BSI policy to supply the BSI implementation of those that have been published as British Standards, unless otherwise requested.

Information on standards

BSI provides a wide range of information on national, European and international standards through its Library and its Technical Help to Exporters Service. Various BSI electronic information services are also available which give details on all its products and services. Contact the Information Centre. Tel: +44 (0)20 8996 7111. Fax: +44 (0)20 8996 7048. Email: info@bsi-global.com.

Subscribing members of BSI are kept up to date with standards developments and receive substantial discounts on the purchase price of standards. For details of these and other benefits contact Membership Administration. Tel: +44 (0)20 8996 7002. Fax: +44 (0)20 8996 7001. Email: membership@bsi-global.com.

Information regarding online access to British Standards via British Standards Online can be found at <http://www.bsi-global.com/bsonline>.

Further information about BSI is available on the BSI website at <http://www.bsi-global.com>.

Copyright

Copyright subsists in all BSI publications. BSI also holds the copyright, in the UK, of the publications of the international standardization bodies. Except as permitted under the Copyright, Designs and Patents Act 1988 no extract may be reproduced, stored in a retrieval system or transmitted in any form or by any means – electronic, photocopying, recording or otherwise – without prior written permission from BSI.

This does not preclude the free use, in the course of implementing the standard, of necessary details such as symbols, and size, type or grade designations. If these details are to be used for any other purpose than implementation then the prior written permission of BSI must be obtained.

Details and advice can be obtained from the Copyright & Licensing Manager. Tel: +44 (0)20 8996 7070. Fax: +44 (0)20 8996 7553. Email: copyright@bsi-global.com.