



BSI Standards Publication

Maritime navigation and radiocommunication equipment and systems — Automatic identification system (AIS)

Part 2: AIS AtoN Stations — Operational and performance requirements, methods of testing and required test results

National foreword

This British Standard is the UK implementation of EN 62320-2:2017. It is identical to IEC 62320-2:2016. It supersedes BS EN 62320-2:2008 which will be withdrawn on 5 December 2019.

The UK participation in its preparation was entrusted to Technical Committee EPL/80, Maritime navigation and radiocommunication equipment and systems.

A list of organizations represented on this committee can be obtained on request to its secretary.

This publication does not purport to include all the necessary provisions of a contract. Users are responsible for its correct application.

© The British Standards Institution 2017.

Published by BSI Standards Limited 2017

ISBN 978 0 580 88383 5

ICS 47.020.70

Compliance with a British Standard cannot confer immunity from legal obligations.

This British Standard was published under the authority of the Standards Policy and Strategy Committee on 28 February 2017.

Amendments/corrigenda issued since publication

Date	Text affected
-------------	----------------------

English Version

Maritime navigation and radiocommunication equipment and systems - Automatic identification system (AIS) - Part 2: AIS AtoN Stations - Operational and performance requirements, methods of testing and required test results (IEC 62320-2:2016)

Equipements et systèmes de navigation et de radiocommunication maritimes - Systèmes d'identification automatique (AIS) - Partie 2: Stations AIS AtoN Exigences minimales opérationnelles et de performance, méthodes de mesure et résultats de test minimum attendus (IEC 62320-2:2016)

Navigations- und Funkkommunikationsgeräte und -systeme für die Seeschifffahrt - Automatische Identifikationssysteme (AIS) - Teil 2: AIS-AtoN-Stationen - Betriebs- und Leistungsanforderungen, Prüfverfahren und geforderte Prüfergebnisse (IEC 62320-2:2016)

This European Standard was approved by CENELEC on 2016-12-05. CENELEC members are bound to comply with the CEN/CENELEC Internal Regulations which stipulate the conditions for giving this European Standard the status of a national standard without any alteration.

Up-to-date lists and bibliographical references concerning such national standards may be obtained on application to the CEN-CENELEC Management Centre or to any CENELEC member.

This European Standard exists in three official versions (English, French, German). A version in any other language made by translation under the responsibility of a CENELEC member into its own language and notified to the CEN-CENELEC Management Centre has the same status as the official versions.

CENELEC members are the national electrotechnical committees of Austria, Belgium, Bulgaria, Croatia, Cyprus, the Czech Republic, Denmark, Estonia, Finland, Former Yugoslav Republic of Macedonia, France, Germany, Greece, Hungary, Iceland, Ireland, Italy, Latvia, Lithuania, Luxembourg, Malta, the Netherlands, Norway, Poland, Portugal, Romania, Serbia, Slovakia, Slovenia, Spain, Sweden, Switzerland, Turkey and the United Kingdom.



European Committee for Electrotechnical Standardization
 Comité Européen de Normalisation Electrotechnique
 Europäisches Komitee für Elektrotechnische Normung

CEN-CENELEC Management Centre: Avenue Marnix 17, B-1000 Brussels

European foreword

The text of document 80/817/FDIS, future edition 2 of IEC 62320-2, prepared by IEC/TC 80 "Maritime navigation and radiocommunication equipment and systems" was submitted to the IEC-CENELEC parallel vote and approved by CENELEC as EN 62320-2:2017.

The following dates are fixed:

- latest date by which the document has to be implemented at national level by publication of an identical national standard or by endorsement (dop) 2017-09-05
- latest date by which the national standards conflicting with the document have to be withdrawn (dow) 2019-12-05

This document supersedes EN 62320-2:2008.

Attention is drawn to the possibility that some of the elements of this document may be the subject of patent rights. CENELEC [and/or CEN] shall not be held responsible for identifying any or all such patent rights.

Endorsement notice

The text of the International Standard IEC 62320-2:2016 was approved by CENELEC as a European Standard without any modification.

In the official version, for Bibliography, the following notes have to be added for the standards indicated:

IEC 61162-1	NOTE	Harmonized as EN 61162-1.
IEC 61162-2	NOTE	Harmonized as EN 61162-2.
IEC 61162-460	NOTE	Harmonized as EN 61162-460.
IEC 61993-2	NOTE	Harmonized as EN 61993-2.

Annex ZA (normative)

Normative references to international publications with their corresponding European publications

The following documents, in whole or in part, are normatively referenced in this document and are indispensable for its application. For dated references, only the edition cited applies. For undated references, the latest edition of the referenced document (including any amendments) applies.

NOTE 1 When an International Publication has been modified by common modifications, indicated by (mod), the relevant EN/HD applies.

NOTE 2 Up-to-date information on the latest versions of the European Standards listed in this annex is available here: www.cenelec.eu

<u>Publication</u>	<u>Year</u>	<u>Title</u>	<u>EN/HD</u>	<u>Year</u>
IEC 60945	-	Maritime navigation and radiocommunication equipment and systems - General requirements - Methods of testing and required test results	EN 60945	-
IEC 61108	Series	Maritime navigation and radiocommunication equipment and systems - Global navigation satellite systems (GNSS)	EN 61108	Series
IEC 62287-1	-	Maritime navigation and radiocommunication equipment and systems - Class B shipborne equipment of the automatic identification system (AIS) - Part 1: Carrier-sense time division multiple access (CSTDMA) techniques	EN 62287-1	-
IEC 62320-3	2015	Maritime navigation and radiocommunication equipment and systems - Automatic identification systems (AIS) - Part 3: AIS Simplex Repeater Station - Minimum operational and performance requirements, methods of testing and required test results	EN 62320-3	2015
ITU Radio Regulations, Appendix 18	-	Table of transmitting frequencies in the VHF maritime mobile band	-	-
ITU-R Recommendation M.1371-5	2014	Technical characteristics for an automatic identification system using time-division multiple access in the VHF maritime mobile band	-	-
IALA Recommendation A-126	-	The use of Automatic Identification System (AIS) in Marine Aids to Navigation	-	-

CONTENTS

FOREWORD	8
1 Scope	10
2 Normative references	10
3 Terms, definitions and abbreviations	11
3.1 Terms and definitions.....	11
3.2 Abbreviated terms.....	11
4 Description	12
4.1 Types of AIS AtoN stations	12
4.2 Type 1 AIS AtoN station.....	15
4.2.1 Characteristics.....	15
4.2.2 Capability	17
4.2.3 Alternatives	17
4.3 Type 2 AIS AtoN station.....	18
4.3.1 Characteristics.....	18
4.3.2 Capability	18
4.3.3 Control receiver	18
4.3.4 Alternatives	18
4.4 Type 3 AIS AtoN Station	19
4.4.1 Characteristics.....	19
4.4.2 Capability	19
4.4.3 AIS receiver (AIS Rx)	19
4.4.4 Alternatives	19
4.5 Optional direct configuration via VDL (types 2 and 3).....	20
4.6 Optional configuration via VDL using chaining (type 3).....	20
5 Requirements for AIS AtoN stations.....	23
5.1 Physical layer	23
5.1.1 Transmitter requirements	23
5.1.2 Receiver requirements.....	25
5.1.3 Power consumption	26
5.1.4 Environmental requirements	26
5.2 Link layer	27
5.2.1 General	27
5.2.2 AIS Messages	27
5.2.3 Synchronisation.....	27
5.2.4 VDL access schemes.....	28
5.2.5 Autonomous mode.....	30
5.2.6 Electronic position fix system.....	31
5.2.7 Built-in integrity test.....	32
5.3 Configuration method.....	33
5.3.1 General	33
5.3.2 Alternative for types 1, 2 and 3	33
5.3.3 Chaining of AIS AtoN stations.....	36
5.4 Repeat broadcast of active AIS-SART message.....	36
5.5 Other requirements	36
5.5.1 Additional features.....	36
5.5.2 Manufacturer's information	36

5.5.3	Marking and identification	37
5.5.4	Additional connection points	37
6	Tests of AIS AtoN stations	37
6.1	General	37
6.2	Test conditions	37
6.2.1	Normal test conditions	37
6.2.2	Extreme test conditions	37
6.2.3	Standard test environment	38
6.2.4	Test signals	38
6.2.5	Arrangements for test signals applied to the receiver input	39
6.2.6	Encoder for receiver measurements	40
6.2.7	Waiver for receivers	40
6.2.8	Impedance	40
6.2.9	Artificial antenna (dummy load)	40
6.2.10	Facilities for access	40
6.2.11	Modes of operation of the transmitter	40
6.2.12	Measurement uncertainties	40
7	RF tests	41
7.1	TDMA transmitter	41
7.1.1	General	41
7.1.2	Frequency error	41
7.1.3	Carrier power	42
7.1.4	Modulation spectrum slotted transmission	42
7.1.5	Transmitter test sequence and modulation accuracy	43
7.1.6	Transmitter output power versus time function (FATDMA and RATDMA)	45
7.2	TDMA receivers (types 2 and 3)	46
7.2.1	Sensitivity	46
7.2.2	Error behaviour at high input levels	47
7.2.3	Co-channel rejection	47
7.2.4	Adjacent channel selectivity	48
7.2.5	Spurious response rejection	49
7.2.6	Inter-modulation response rejection	52
7.2.7	Blocking or desensitization	53
7.3	Conducted spurious emissions at the antenna	54
7.3.1	Spurious emissions from the receiver	54
7.3.2	Spurious emissions from the transmitter	54
8	Functional tests	55
8.1	Configuration method	55
8.1.1	General	55
8.1.2	Configuration for Message 21	55
8.1.3	Schedule mode A FATDMA Message 21 (single report, alternating channel operation)	56
8.1.4	Schedule mode B FATDMA Message 21 (dual report, dual channel operation)	57
8.1.5	Schedule mode C FATDMA Message 21 (single report, single channel operation)	57
8.1.6	Schedule mode A RATDMA Message 21 (Type 3) (single report, alternating channel operation)	58
8.1.7	Schedule mode B RATDMA Message 21 (Type 3) (dual report, dual channel operation)	59

8.1.8	Schedule mode C RATDMA Message 21 (type 3) (single channel operation)	59
8.1.9	Scheduled transmission of Message 6	60
8.1.10	Scheduled transmission of Message 8	61
8.1.11	Scheduled transmission of Message 12	61
8.1.12	Scheduled transmission of Message 14	61
8.1.13	Unscheduled transmission	62
8.2	Synchronisation accuracy	62
8.2.1	Implemented synchronisation modes and synchronisation error	62
8.2.2	Synchronisation test without UTC (types 2 and 3)	63
8.3	EPFS	64
8.3.1	Position source	64
8.3.2	Invalid position	64
8.3.3	Off-position monitor	64
8.4	Receive addressed message (types 2 and 3)	65
8.4.1	Purpose	65
8.4.2	Method of measurement	65
8.4.3	Required results	65
8.5	Interrogation response (Type 3)	65
8.5.1	Purpose	65
8.5.2	Method of measurement	65
8.5.3	Required results	66
8.6	Repeat AIS-SART messages	66
8.6.1	Purpose	66
8.6.2	Method of measurement	66
8.6.3	Required results	66
8.7	Additional functionality as implemented by the manufacturer	66
8.7.1	Test for configuration of the receiver turn-on times (types 2 and 3)	66
8.7.2	Test for configuration of payload transmission	67
8.7.3	Test for forced broadcast	68
8.7.4	Test for version information	68
8.7.5	Test for DCR – AtoN function ID capability	69
8.7.6	Test for assigning an encryption key for VDL configuration	69
8.7.7	Test for VDL configuration using chaining (Type 3)	70
8.8	BIIT	75
8.8.1	Purpose	75
8.8.2	Method of measurement	75
8.8.3	Required results	75
8.9	Transmitter shutdown procedure	75
8.9.1	Purpose	75
8.9.2	Method of measurement	75
8.9.3	Required results	75
8.10	Power supply	75
8.10.1	Purpose	75
8.10.2	Method of measurement	76
8.10.3	Required results	76
8.11	Environmental	76
8.12	External removable media	76
8.12.1	Purpose	76

8.12.2	Method of measurement	76
8.12.3	Required results	76
8.13	Other tests	76
8.13.1	Quality assurance	76
8.13.2	Additional features	76
8.13.3	Manual	77
8.13.4	Marking and identification	77
8.14	Optional TAG block encapsulation	77
8.14.1	Application	77
8.14.2	TAG block capabilities	77
8.14.3	Activation of source-identification for output	77
8.14.4	Activation of Destination-identification	78
8.14.5	Activation of Source-identification for input	79
8.14.6	Use of multiple source-identifications for input	80
8.14.7	Test of grouping by TAG blocks for output	81
8.14.8	Test of UNIX time output	82
8.14.9	Test of line-count output	82
Annex A (informative)	AIS AtoN station configuration structures	84
A.1	AIS AtoN station configuration structures	84
A.2	MMSI Identification configuration command (AID)	87
A.3	Extended/general AtoN station configuration command (ACF/ACG)	89
A.4	Configure broadcast rates for AtoN Station message command (CBR)	94
A.5	Configuration of encryption key (CEK)	97
A.6	Configure the receiver turn-on times (ARW)	98
A.7	Proprietary AtoN control command (MCR)	99
A.8	Configuration of message payload for broadcast (MEB)	101
A.9	Forced broadcast command (AFB)	101
A.10	Version information (VER)	102
A.11	AtoN function ID capability	104
A.12	Query via the VDL for Message 21 content	105
A.13	General query request	106
A.14	Configuration of receiver operational times command (COP)	107
A.15	Configuration of message payload for broadcast (MEB)	108
A.16	Query response via the VDL for Message 21 configuration	110
Annex B (normative)	Message 21 – AtoN status bits	113
Bibliography	114
Figure 1	– Functional block diagram of a Type 1 AIS AtoN Station	16
Figure 2	– Functional block diagram of a type 2 AIS AtoN station	18
Figure 3	– Functional block diagram of a type 3 AIS AtoN station	19
Figure 4	– VDL configuration decision tree	22
Figure 5	– Power versus time mask	29
Figure 6	– Reporting modes for Message 21	31
Figure 7	– Block diagram of AIS AtoN test setup	38
Figure 8	– Format for repeating four-packet cluster	39
Figure 9	– Measurement arrangement for frequency error	41
Figure 10	– Measurement arrangement for carrier power	42

Figure 11 – Emission mask	43
Figure 12 – Measurement arrangement for modulation accuracy	44
Figure 13 – Measurement arrangement for sensitivity	46
Figure 14 – Measurement arrangement for error behaviour	47
Figure 15 – Measurement arrangement for co-channel rejection	48
Figure 16 – Measurement arrangement for adjacent channel selectivity	49
Figure 17 – PER/BER or SINAD measuring equipment	50
Figure 18 – Measurement arrangement for inter-modulation	52
Figure 19 – Measurement arrangement for blocking or desensitisation	53
Figure 20 – Test scenario for basic chaining test	70
Figure 21 – Test scenario for linear chaining test	72
Figure 22 – Test scenario for forked chaining test	73
Figure B.1 – Use of AtoN status bits as IALA A-126 Page ID 7	113
Table 1 – Description of AIS AtoN stations	13
Table 2 – Use of VDL messages	14
Table 3 – Summary of optional Type 1 AIS AtoN Station messages	17
Table 4 – Summary of optional Type 3 AIS AtoN Station messages	20
Table 5 – Configuration of AIS AtoN stations via VDL	23
Table 6 – Required parameter settings for an AIS AtoN Station	24
Table 7 – Required settings of physical layer constants	24
Table 8 – Modulation parameters of the physical layer of the AIS AtoN station	24
Table 9 – Minimum required TDMA transmitter characteristics	25
Table 10 – Required receiver characteristics	26
Table 11 – Maximum allowed time error	28
Table 12 – Definitions of timing for Figure 5	30
Table 13 – AIS AtoN Station reaction to BIIT conditions	33
Table 14 – Standard sentences	34
Table 15 – DCR Capabilities	35
Table 16 – Optional TAG Block functions	36
Table 17 – Content of first two packets	39
Table 18 – Fixed PRS data derived from ITU-T O.153	39
Table 19 – Maximum values of absolute measurement uncertainties	41
Table 20 – Peak frequency deviation versus time	45
Table 21 – Definition of timings	45
Table 22 – Frequencies for inter-modulation test	53
Table A.1 – Parameter setting in Message 25 for AIS AtoN Station applications	84
Table A.2 – Parameter setting in Message 6 for AIS AtoN Station applications	85
Table A.3 – Message 25 or 6 function identifier used for configuration and query via the VDL	86
Table A.4 – Configuration via the VDL for MMSI identification	88
Table A.5 – Query via the VDL for MMSI identification	88
Table A.6 – Query response via the VDL for MMSI identification	89

Table A.7 – Configuration via the VDL, Part 1	90
Table A.8 – Configuration via the VDL, Part 2	90
Table A.9 – Configuration via the VDL, Part 3	91
Table A.10 – Configuration via the VDL, Part 4 (first 12 characters of AtoN name).....	91
Table A.11 – Configuration via the VDL, Part 5 (second 12 characters of AtoN name)	92
Table A.12 – Configuration via the VDL, Part 6 (third (last) 10 characters of AtoN name)	92
Table A.13 – Query request via the VDL	92
Table A.14 – Query response via the VDL, Part 1	93
Table A.15 – Query response via the VDL, Part 2	94
Table A.16 – Configuration via the VDL for FATDMA	95
Table A.17 – Configuration via the VDL for RATDMA/CSTDMA.....	96
Table A.18 – Query request via the VDL for AtoN broadcast rates	96
Table A.19 – Query response via the VDL with AtoN broadcast rates.....	97
Table A.20 – Configuration via the VDL of encryption key	98
Table A.21 – Configuration via the VDL for receiver turn-on times	98
Table A.22 – Query request via the VDL for receiver turn-on times	99
Table A.23 – Query response via the VDL for receiver turn-on times.....	99
Table A.24 – Configuration via the VDL for proprietary information	100
Table A.25 – Query request via the VDL for proprietary information	100
Table A.26 – Query response via the VDL for proprietary information	100
Table A.27 – Configuration or function via the VDL of message payload	101
Table A.28 – Function via the VDL for forced broadcast.....	102
Table A.29 – Query request via the VDL for VER	103
Table A.30 – Query response via the VDL for VER	104
Table A.31 – Query request via the VDL for function ID	104
Table A.32 – Query response via the VDL for function ID.....	105
Table A.33 – Query request via the VDL for Message 21 content.....	106
Table A.34 – Query response via the VDL for Message 21 content	106
Table A.35 – General query request via the VDL	107
Table A.36 – Configuration via the VDL for COP	108
Table A.37 – Payload control configuration via the VDL	109
Table A.38 – Payload binary data via the VDL	110
Table A.39 – Query response via the VDL, Message 21 configuration.....	111
Table A.40 – Query response via the VDL, first 12 characters of AtoN name	111
Table A.41 – Query response via the VDL, second 12 characters of AtoN name	112
Table A.42 – Query response via the VDL, last 10 characters of AtoN name.....	112
Table B.1 – AtoN status pages.....	113

INTERNATIONAL ELECTROTECHNICAL COMMISSION

**MARITIME NAVIGATION AND RADIOCOMMUNICATION EQUIPMENT
AND SYSTEMS – AUTOMATIC IDENTIFICATION SYSTEM (AIS) –****Part 2: AIS AtoN Stations – Operational and performance
requirements, methods of testing and required test results**

FOREWORD

- 1) The International Electrotechnical Commission (IEC) is a worldwide organization for standardization comprising all national electrotechnical committees (IEC National Committees). The object of IEC is to promote international co-operation on all questions concerning standardization in the electrical and electronic fields. To this end and in addition to other activities, IEC publishes International Standards, Technical Specifications, Technical Reports, Publicly Available Specifications (PAS) and Guides (hereafter referred to as "IEC Publication(s)"). Their preparation is entrusted to technical committees; any IEC National Committee interested in the subject dealt with may participate in this preparatory work. International, governmental and non-governmental organizations liaising with the IEC also participate in this preparation. IEC collaborates closely with the International Organization for Standardization (ISO) in accordance with conditions determined by agreement between the two organizations.
- 2) The formal decisions or agreements of IEC on technical matters express, as nearly as possible, an international consensus of opinion on the relevant subjects since each technical committee has representation from all interested IEC National Committees.
- 3) IEC Publications have the form of recommendations for international use and are accepted by IEC National Committees in that sense. While all reasonable efforts are made to ensure that the technical content of IEC Publications is accurate, IEC cannot be held responsible for the way in which they are used or for any misinterpretation by any end user.
- 4) In order to promote international uniformity, IEC National Committees undertake to apply IEC Publications transparently to the maximum extent possible in their national and regional publications. Any divergence between any IEC Publication and the corresponding national or regional publication shall be clearly indicated in the latter.
- 5) IEC itself does not provide any attestation of conformity. Independent certification bodies provide conformity assessment services and, in some areas, access to IEC marks of conformity. IEC is not responsible for any services carried out by independent certification bodies.
- 6) All users should ensure that they have the latest edition of this publication.
- 7) No liability shall attach to IEC or its directors, employees, servants or agents including individual experts and members of its technical committees and IEC National Committees for any personal injury, property damage or other damage of any nature whatsoever, whether direct or indirect, or for costs (including legal fees) and expenses arising out of the publication, use of, or reliance upon, this IEC Publication or any other IEC Publications.
- 8) Attention is drawn to the Normative references cited in this publication. Use of the referenced publications is indispensable for the correct application of this publication.
- 9) Attention is drawn to the possibility that some of the elements of this IEC Publication may be the subject of patent rights. IEC shall not be held responsible for identifying any or all such patent rights.

International Standard IEC 62320-2 has been prepared by IEC technical committee 80: Maritime navigation and radiocommunication equipment and systems.

This second edition cancels and replaces the first edition, published in 2008, and constitutes a technical revision.

This edition includes the following significant technical changes with respect to the previous edition:

- additional cyber security measures;
- updated description of configuration via VDL;
- updated VDL access scheme requirements;
- new PI sentences and VDL message structures with added description for optional TAG blocks;

- added requirement for at least one standard method for configuration using Standard PI sentences;
- updated test methods and updated Annexes.

The text of this standard is based on the following documents:

FDIS	Report on voting
80/817/FDIS	80/822/RVD

Full information on the voting for the approval of this standard can be found in the report on voting indicated in the above table.

This publication has been drafted in accordance with the ISO/IEC Directives, Part 2.

A list of all parts in the IEC 62320 series, published under the general title *Maritime navigation and radiocommunication equipment and systems – Automatic identification system (AIS)*, can be found on the IEC website.

The committee has decided that the contents of this publication will remain unchanged until the stability date indicated on the IEC web site under "<http://webstore.iec.ch>" in the data related to the specific publication. At this date, the publication will be

- reconfirmed,
- withdrawn,
- replaced by a revised edition, or
- amended.

A bilingual version of this publication may be issued at a later date.

IMPORTANT – The 'colour inside' logo on the cover page of this publication indicates that it contains colours which are considered to be useful for the correct understanding of its contents. Users should therefore print this document using a colour printer.

MARITIME NAVIGATION AND RADIOCOMMUNICATION EQUIPMENT AND SYSTEMS – AUTOMATIC IDENTIFICATION SYSTEM (AIS) –

Part 2: AIS AtoN Stations – Operational and performance requirements, methods of testing and required test results

1 Scope

This part of IEC 62320 specifies the operational and performance requirements, methods of testing and required test results for AIS AtoN Stations compatible with the performance standards adopted by IMO Resolution MSC.74(69), Annex 3, Universal AIS. It incorporates the technical characteristics of non-shipborne AIS AtoN equipment, included in Recommendation ITU-R M.1371 and IALA Recommendation A-126. Where applicable, it also takes into account the ITU Radio Regulations. This standard takes into account other associated IEC International Standards and existing national standards, as applicable.

This document is applicable for automatic identification system (AIS) installations on aids to navigation (AtoN).

2 Normative references

The following referenced documents are indispensable for the application of this document. For dated references, only the edition cited applies. For undated references, the latest edition of the referenced document (including any amendments) applies.

IEC 60945, *Maritime navigation and radiocommunication equipment and systems – General requirements – Methods of testing and required test results*

IEC 61108 (all parts), *Maritime navigation and radiocommunication equipment and systems – Global navigation satellite systems (GNSS)*

IEC 62287-1, *Maritime navigation and radiocommunication equipment and systems – Class B shipborne equipment of the automatic identification system (AIS) – Part 1: Carrier-sense time division multiple access (CSTDMA) techniques*

IEC 62320-3:2015, *Maritime navigation and radiocommunication equipment and systems – Automatic identification systems (AIS) – Part 3: Repeater station – Minimum operational and performance requirements – Methods of test and required test results*

ITU Radio Regulations, Appendix 18, *Table of transmitting frequencies in the VHF maritime mobile band*

ITU-R Recommendation M.1371-5:2014, *Technical characteristics for an automatic identification system using time division multiple access in the VHF maritime mobile band*

IALA Recommendation A-126, *The Use of Automatic Identification System (AIS) in Marine Aids to Navigation*

3 Terms, definitions and abbreviations

3.1 Terms and definitions

For the purposes of this document, the following terms and definitions apply.

3.1.1

aids to navigation

AtoN

device or system external to vessels that is designed and operated to enhance the safe and efficient navigation of vessels and/or vessel traffic

3.1.2

Message 21

AtoN report transmitted on the VHF data link by an AIS station

3.1.3

real AIS AtoN

AIS AtoN station which is physically located on the aid to navigation

Note 1 to entry: IMO MSC.1/Circ.1473 states that physical AIS AtoN is an AIS Message 21 representing an aid to navigation that physically exists.

3.1.4

synthetic AIS AtoN

Message 21 transmitted from an AIS station located remotely from the aid to navigation

Note 1 to entry: IMO MSC.1/Circ.1473 states that physical AIS AtoN is an AIS Message 21 representing an aid to navigation that physically exists.

3.1.5

virtual AIS AtoN

Message 21 transmitted from an AIS station for an aid to navigation which does not physically exist

3.2 Abbreviated terms

AES	Advanced Encryption Standard
AIS	automatic identification system
BIIT	built-in integrity test
BT	bandwidth-time product
CSTDMA	carrier sense time division multiple access
DGNSS	differential global navigation satellite system
EPFS	electronic position fixing system
EUT	equipment under test
FATDMA	fixed access time division multiple access
GNSS	global navigation satellite system
IMO	International Maritime Organization
MMSI	Maritime Mobile Service Identity
NRZI	non-return to zero inverted
PER	packet error rate
PI	presentation interface
RAIM	receiver autonomous integrity monitoring
RATDMA	random access time division multiple access

RF	radio frequency
Rx	receive
SBAS	satellite-based augmentation system
SOTDMA	self-organizing time division multiple access
TDMA	time division multiple access
Tx	transmit
UTC	Coordinated Universal Time
VDL	VHF data link
VHF	very high frequency
VSWR	voltage standing wave ratio

4 Description

4.1 Types of AIS AtoN stations

There are three types of AIS AtoN stations as defined in Table 1. The AIS AtoN stations may optionally include additional capabilities as defined in the comments column. Table 2 describes the use of the messages.

Table 1 – Description of AIS AtoN stations

Requirements	Type 1 AIS AtoN station	Type 2 AIS AtoN station	Type 3 AIS AtoN station	Comments
VDL receiver	No receiver	Receiver for query, configuration, or control functions only	Two receiving processes for autonomous mode (RATDMA)	When RATDMA is not used, only one receiving process is required for autonomous mode.
Transmitted messages	21			See Table 2.
Access mode for Message 21	FATDMA	FATDMA	FATDMA & RATDMA	
Access Mode for messages other than 21, if implemented	FATDMA	FATDMA	FATDMA & RATDMA	CSTDMA (Type 3)
Configuration / communication method	Standard sentences of Table 14 Physical interface defined by manufacturer			Defined by the manufacturer with standard sentences and optionally using TAG Blocks.
Physical communication interface	At least one shall be provided by the manufacturer for test. Not required for operation.			The electrical and physical characteristics shall be defined by the manufacturer.
Transmit power	Nominal 12,5 W			As defined by the manufacturer
Transmitter capability	Frequency agile			Single frequency
Synthetic and Virtual AtoN	Not Required			Yes
Positioning device	EPFS and surveyed position			Surveyed position only (no EPFS)
UTC synchronisation	UTC Direct			UTC indirect or semaphore (Type 3)
Assignment	Shall not respond to assignment Messages 16 and 23			
Interrogation	Shall respond with the Message 21 of the Real AIS AtoN MMSI only.			
Default (initial factory setting)	MMSI = 00000000 No schedule configured No virtual AtoN configured Radio parameters configured per Table 6 No surveyed position Encryption key = all zeros AtoN status bits = all zeros			

Table 2 – Use of VDL messages

Msg. No.	Name of message	M.1371-5 Ref.	R/P Type 2	R/P Type 3	PI Output	T Type 1&2	T Type 3	Remark
0	Undefined	None	No	No	No	No	No	Reserved for future use
1	Position report (scheduled)	A8-3.1	No	Yes	Yes	No	Opt	Comm State requires evaluation if RATDMA enabled Only implemented to repeat active AIS-SART messages
2	Position report (assigned)	A8-3.1	No	Yes	Yes	No	No	Comm State requires evaluation if RATDMA enabled
3	Position report (when interrogated)	A8-3.1	No	Yes	Yes	No	No	Comm State requires evaluation if RATDMA enabled
4	Base station report	A8-3.2	No	Yes	Yes	No	No	Comm State requires evaluation if RATDMA enabled
5	Static and voyage related data	A8-3.3	No	No	Yes	No	No	
6	Addressed binary message	A8-3.4	Opt	Opt	Yes	Opt	Opt	Only if addressed to own station including virtual MMSIs associated with own station, or 0
7	Binary acknowledge	A8-3.5	Opt	Opt	Opt	No	Opt	
8	Binary broadcast message	A8-3.6	No	No	Yes	Opt	Opt	
9	Standard SAR aircraft position report	A8-3.7	No	Yes	Yes	No	No	Comm State requires evaluation if RATDMA enabled
10	UTC and date inquiry	A8-3.8	No	No	Opt	No	No	
11	UTC/ date response	A8-3.9	No	No	Opt	No	No	
12	Addressed safety related message	A8-3.10	No	Opt	Yes	Opt	Opt	Only if addressed to own station including virtual MMSIs associated with own station, or 0
13	Safety related acknowledge	A8-3.11	No	Opt	Opt	No	Opt	
14	Safety related broadcast message	A8-3.12	No	Opt	Yes	Opt	Opt	
15	Interrogation	A8-3.13	Opt	Opt	Opt	No	No	Shall respond with the Message 21 of the Real AIS AtoN MMSI only
16	Assigned mode command	A8-3.14	No	No	Opt	No	No	
17	DGNSS	A8-3.15	No	Opt	Opt	No	No	
18	Standard Class B equipment position report	A8-3.16	No	Yes	Yes	No	No	Comm State requires evaluation if RATDMA enabled

Msg. No.	Name of message	M.1371-5 Ref.	R/P Type 2	R/P Type 3	PI Output	T Type 1&2	T Type 3	Remark
19	Extended Class B equipment position report	A8-3.17	No	No	Opt	No	No	
20	Data link management message	A8-3.18	No	No	Opt	No	No	
21	Aids-to-Navigation report	A8-3.19	No	No	Yes	Yes	Yes	
22	Channel management message	A8-3.20	No	No	Opt	No	No	
23	Group assignment command	A8-3.21	No	No	Opt	No	No	
24	Static data report (single slot, two parts)	A8-3.22	No	No	Yes	No	No	
25	Single slot binary message	A8-3.23	Opt	Opt	Yes	Yes	Yes	Only if addressed to own station including virtual MMSIs associated with own station, or 0
26	Multiple slot binary message	A8-3.24	Opt	Yes	Yes	Yes	Yes	Comm State requires evaluation if RATDMA enabled Only if addressed to own station including virtual MMSIs associated with own station, or 0
27	Long-range AIS broadcast message	A8-3.25	No	No	Opt	No	No	
28 to 63	Undefined	None	No	No	No	No	No	Reserved for future use
Key:								
R/P: Receive and process internally, e.g. prepare for output via PI, act upon the received information, and use the received information internally.								
O: Output message content via PI using PI VDM messages								
T: Transmission by own station: "Yes" = required; "No" = shall not be transmitted								
INF: VDL message will be output via PI using a PI VDM message for information only. This function may be suppressed by the configuration setting.								

4.2 Type 1 AIS AtoN station

4.2.1 Characteristics

4.2.1.1 General

Type 1 AIS AtoN station has no receiver. It transmits on FATDMA slots given in its configuration. Figure 1 shows the functional block diagram of a Type 1 AIS AtoN station.

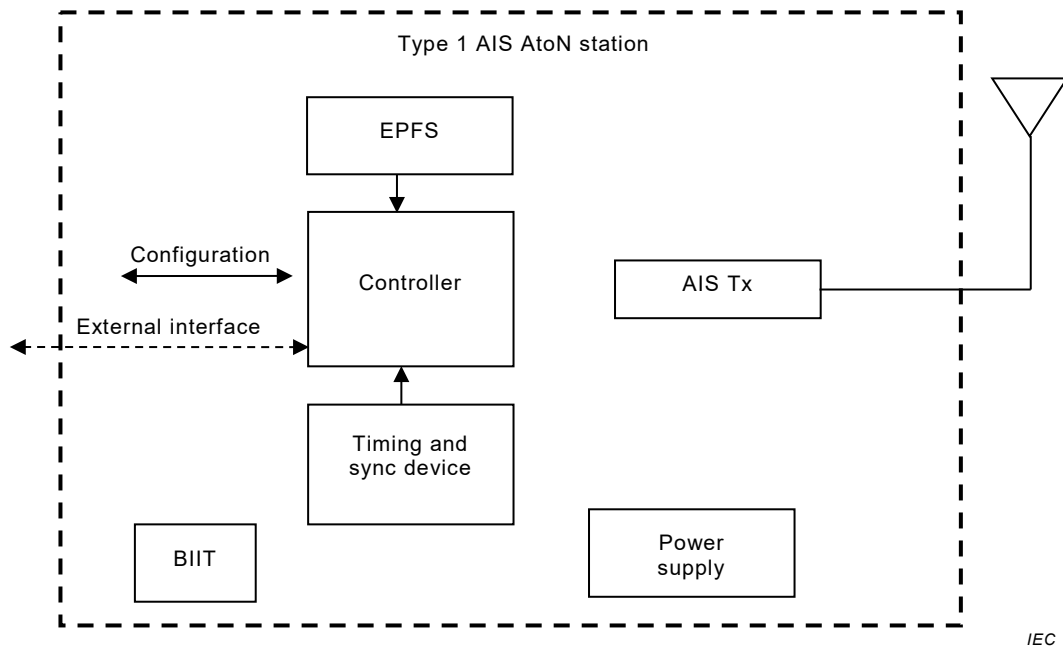

Figure 1 – Functional block diagram of a Type 1 AIS AtoN Station

The characteristics of the type 1 AIS AtoN station are:

- transmits using FATDMA;
- no receive capability, therefore:
 - cannot be configured via the VDL,
 - cannot synchronise to other stations;
- configuration interface as defined by the manufacturer;
- 12,5 W nominal transmitter power or as defined by the manufacturer;
- dual channel transmission.

4.2.1.2 Controller

The controller composes Message 21 and ensures the correct operation of the AIS AtoN station on the VDL.

4.2.1.3 Timing and synchronisation device

This device provides the time and synchronisation for the controller.

4.2.1.4 Power supply

The power supply generates the internal voltages.

4.2.1.5 BIIT

The built-in integrity tests (BIIT) shall provide integrity monitoring.

4.2.1.6 EPFS

Electronic position fixing system (EPFS) provides the current position of the AtoN.

4.2.1.7 Configuration

The interface used to configure the AIS AtoN station.

4.2.2 Capability

Type 1 AIS AtoN station is capable of transmitting Message 21 using FATDMA.

4.2.3 Alternatives

4.2.3.1 Additional controller capability

In addition to Message 21, the controller shall compose optional output messages to the VDL using FATDMA as described in Table 3. No other messages are allowed. Also the Type 1 AIS AtoN station should not retransmit the addressed binary message (Messages 6 and 12). The number of retries should be set to 0.

Table 3 – Summary of optional Type 1 AIS AtoN Station messages

Msg. ID	Message name	Message description	Application examples
6	Binary addressed message	Binary data for addressed communication	Monitoring of AtoN lantern, power supply, etc.
8	Binary broadcast message	Binary data for broadcast communication	Meteorological and hydrological data
12	Addressed safety related message	Safety related data for addressed communication	Warn AtoN malfunctioning
14	Broadcast safety related message	Safety related data for broadcast communication	Warn AtoN malfunctioning
25	Single slot binary message	Binary data for addressed or broadcast communication	Status report

4.2.3.2 Configuration method

The type 1 AIS AtoN station may be configured using standard configuration sentences (IEC 61162-1 and as described in NMEA 1083:June 2012).

4.2.3.3 No EPFS

When a surveyed position is used, the EPFS may not be required.

4.2.3.4 TDMA transmitter (AIS Tx)

The TDMA transmitter may operate on a single channel.

4.2.3.5 External interface

The external interface(s) may be used for communication with external devices (for example AtoN lantern, AtoN power supply, hydrological and meteorological instruments, etc.).

4.2.3.6 Synthetic and Virtual AtoN

The AIS AtoN station may be capable of transmitting Message 21 for synthetic and virtual AIS AtoN.

4.3 Type 2 AIS AtoN station

4.3.1 Characteristics

Type 2 AIS AtoN station transmits on FATDMA slots.

Type 2 AIS AtoN station has a control receiver for messages containing configuration sentences (see NMEA 0183:June 2012). Figure 2 shows the functional block diagram of a type 2 AIS AtoN station.

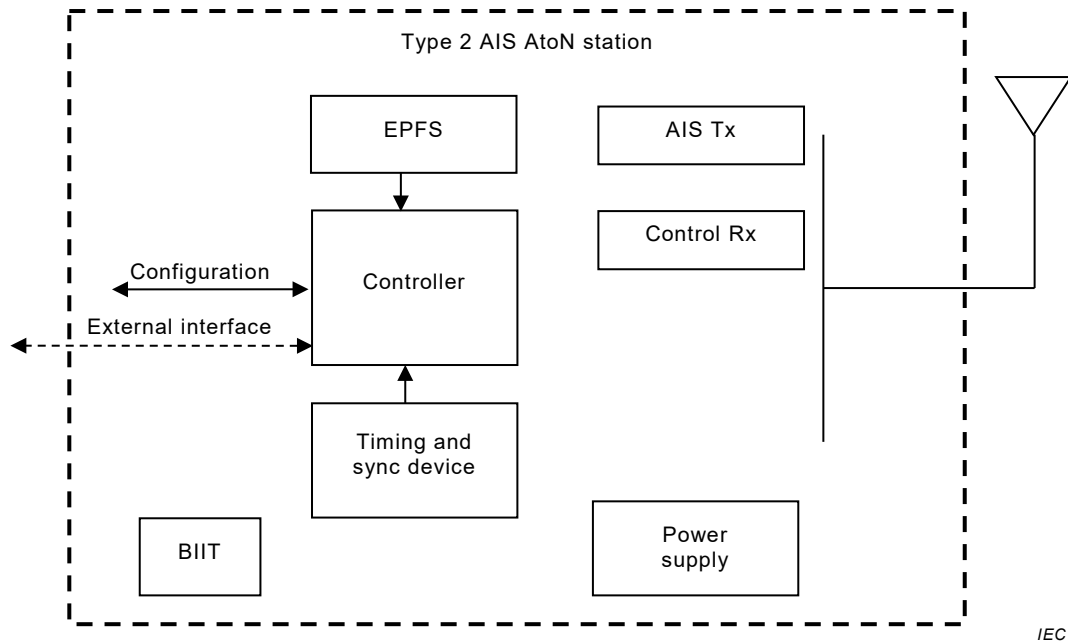

IEC

Figure 2 – Functional block diagram of a type 2 AIS AtoN station

The characteristics of the type 2 AIS AtoN station are:

- transmits using FATDMA;
- limited receiver capability, therefore cannot maintain a slot map and cannot use RATDMA access scheme;
- configuration interface as defined by the manufacturer;
- 12,5 W nominal transmitter power or as defined by the manufacturer;
- dual channel transmission.

4.3.2 Capability

A type 2 AIS AtoN station has the capabilities of a type 1 AIS AtoN station, with the addition of a control receiver.

4.3.3 Control receiver

The type 2 AIS AtoN station shall have a receiver operating on an AIS channel for control functions only.

4.3.4 Alternatives

The type 2 AIS AtoN station alternatives include all the type 1 AIS AtoN station alternatives as described in Table 3.

4.4 Type 3 AIS AtoN Station

4.4.1 Characteristics

Type 3 AIS AtoN station has AIS receive and transmit capabilities in accordance with Recommendation ITU-R M.1371. Figure 3 shows the functional block diagram of a type 3 AIS AtoN station.

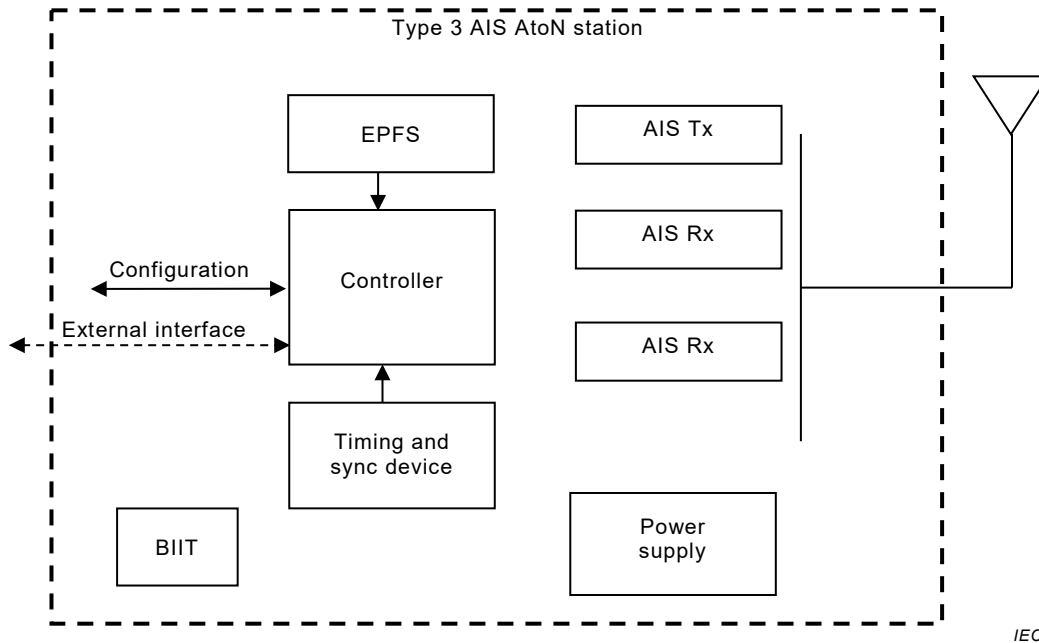

Figure 3 – Functional block diagram of a type 3 AIS AtoN station

The characteristics of the Type 3 AIS AtoN station are:

- reception capability on both AIS channels,
- transmission using FATDMA.

4.4.2 Capability

A type 3 AIS AtoN station has the capability of a type 1 AIS AtoN station, with the addition of AIS receivers.

4.4.3 AIS receiver (AIS Rx)

The type 3 AIS AtoN station shall have two AIS (TDMA) receiving processes to produce and maintain a slot map for autonomous interaction with the VDL.

4.4.4 Alternatives

4.4.4.1 General

The type 3 AIS AtoN station alternatives include all the type 1 and type 2 AIS AtoN station alternatives, with the additions of 4.4.4.2, 4.4.4.3 and 4.4.4.4.

4.4.4.2 Additional controller capability

In addition to Message 21, the controller composes optional output messages to the VDL as described in Table 4. No other messages are allowed, except repeating of SART messages, see 5.4.

Table 4 – Summary of optional Type 3 AIS AtoN Station messages

Msg. ID	Message name	Message description	Application examples
6	Binary addressed message	Binary data for addressed communication	Monitoring of AtoN equipment
7	Binary acknowledge message	Acknowledge of addressed binary message	
8	Binary broadcast message	Binary data for broadcast communication	Meteorological and hydrological data
12	Addressed safety related message	Safety related data for addressed communication	Warn AtoN malfunctioning
13	Safety related acknowledge message	Acknowledge of addressed safety related message	
14	Broadcast safety related message	Safety related data for broadcast communication	Warn AtoN malfunctioning
25	Single slot binary message	Binary data for addressed or broadcast communication	Status report
26	Multiple slot binary message	Binary data for addressed or broadcast communication	Status report

4.4.4.3 Access mode

4.4.4.3.1 Message 21

Transmits using FATDMA or RATDMA.

4.4.4.3.2 Messages other than Message 21

For each message other than Message 21, the type 3 AIS AtoN station may use FATDMA, CSTDMA or RATDMA.

4.4.4.4 Indirect and semaphore synchronisation

A type 3 AIS AtoN station may optionally synchronise to other AIS stations using UTC indirect synchronisation or other AIS stations acting as semaphore.

4.5 Optional direct configuration via VDL (types 2 and 3)

An AIS AtoN station can be configured via the VDL using Messages 6 or 25 with encrypted binary data as defined in Annex A.

The AIS AtoN station shall attempt to decrypt the binary data, and check that it is the intended recipient of the message before processing the message any further (see Table 5).

AES encryption with a key length of 128 bits is used to encrypt the configuration data over the VDL. The manufacturer may implement a longer key length. This shall be mentioned in the manual.

4.6 Optional configuration via VDL using chaining (type 3)

A chain of AIS AtoN stations allows for communication from a configuring AIS station to AIS AtoN stations that may be unable to communicate directly with the configuring AIS station. The messages are passed from station to station until the intended recipient is reached, see Figure 4.

The concept requires an AIS AtoN station to have knowledge of other AIS AtoN stations in the chain, namely its parent and all children below it in the chain. A “parent station” is a station that is in the direction of the configuring AIS station. A “child station” is a station that is

directed away from a configuring AIS station. In order to prevent unnecessary retransmission of the messages, each AIS AtoN station in a chain shall have only one parent, but may have multiple children (this includes all synthetic and virtual AIS AtoN).

Message 6 or 25 is used for the transfer of the encrypted binary field. It is assumed that the whole chain has the same encryption key. The source ID and “MMSI of AtoN” fields of Message 6 or 25 is used to determine whether the received message is from a parent or child station. If not, then the received message is ignored.

When Message 6 is used, the destination ID shall be own station MMSI or zero. If the destination is zero, the message shall not be processed unless the source ID is the parent.

The encrypted binary data field is decrypted to obtain the function ID and “MMSI of AtoN”. If the source ID of the message is set to the parent station ID and the function ID is a configuration, query request or function, and the MMSI of the AIS AtoN station is in the chain, then the message shall be retransmitted, with the source ID set to its own MMSI. If the source ID of the message is set to a child MMSI and the function ID is a query response, then the message shall be retransmitted, with the destination ID set to the parent MMSI. Any other combination of known or unknown MMSI is ignored (see Table 5).

The AIS AtoN station shall attempt to decrypt the binary data, and check that it, or one of its children, is the intended recipient of the message, before processing the message any further.

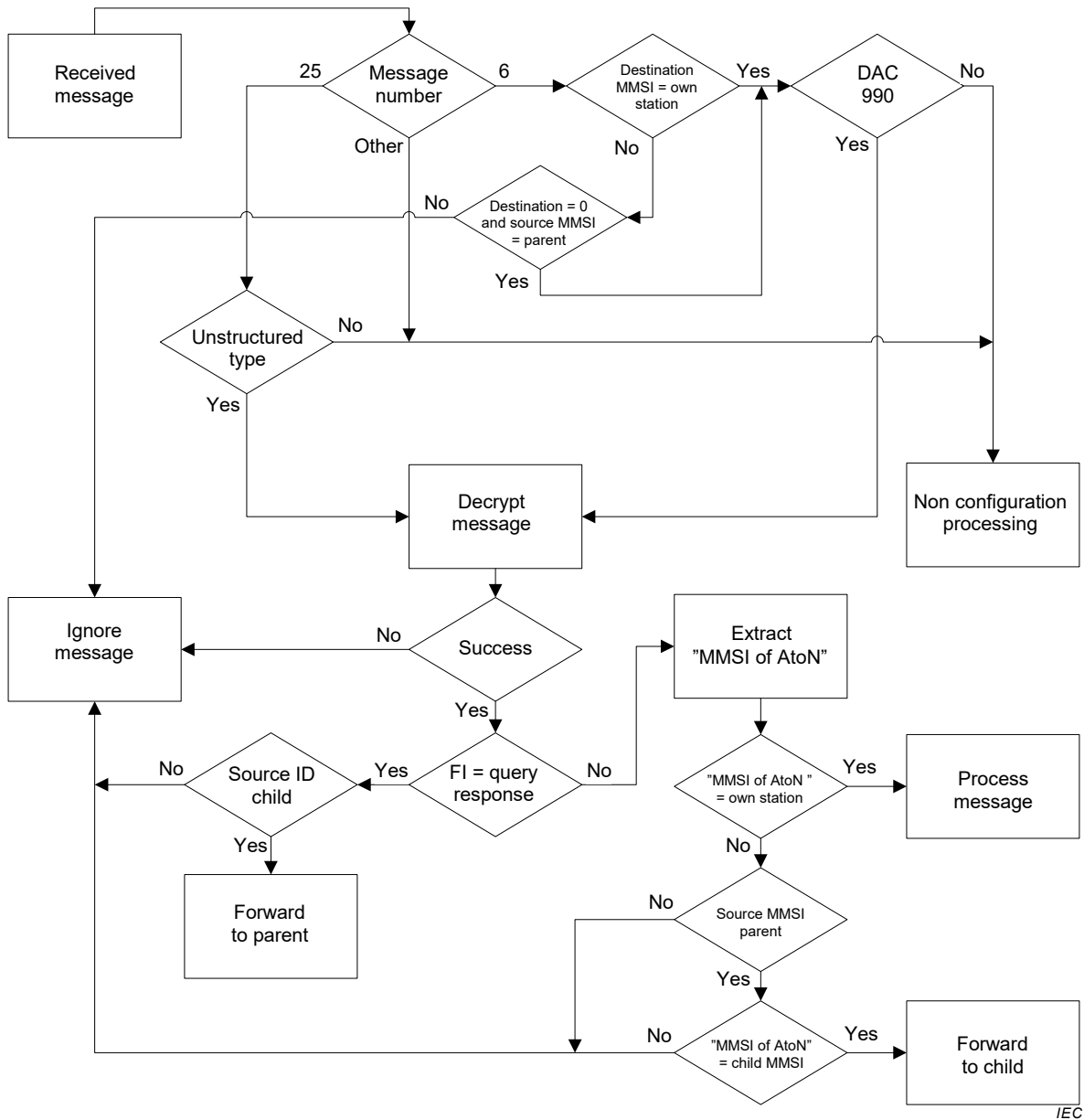

Figure 4 – VDL configuration decision tree

Table 5 – Configuration of AIS AtoN stations via VDL

Source ID	Type of Message according to function ID from Table in A.1	“MMSI of AtoN” from encrypted binary field	Action by own station
Parent	Query response	Any	Ignore
Parent	Configuration, functional or query request	Not own station	Verify that the destination ID = own MMSI or 0 ^b , then verify intended recipient is a child and re-transmit message with source ID set to own station MMSI.
Parent	Configuration or functional	Own station	Verify that the destination ID = own MMSI or 0 ^b , then process
Parent	Query request	Own station	Verify that the destination ID = own MMSI or 0 ^b , then send response with “MMSI of AtoN” = own station
Child	Query response	Any	Re-transmit message to the parent without changing the “MMSI of AtoN”
Child	Configuration, query request or functional	Any	Ignore
Other ^a	Configuration or functional	Own station	Verify that the destination ID = own MMSI ^b , then process
Other ^a	Query request	Own station	Verify that the destination ID = own MMSI ^b , then send response with “MMSI of AtoN” = own station
Other ^a	Any	Not own station	Ignore
^a Other is any MMSI that is not a parent or child			
^b Only check when Message 6 is used			

5 Requirements for AIS AtoN stations

5.1 Physical layer

5.1.1 Transmitter requirements

5.1.1.1 Channel

The AIS AtoN station shall operate on dual channels, channel 1 and channel 2, in the VHF maritime mobile service band, using 25 kHz bandwidth, according to the ITU Radio Regulations, Appendix 18.

5.1.1.2 Channel alternatives

The type 1, type 2 and type 3 AIS AtoN stations may transmit on a single channel only, either channel 1 or channel 2.

5.1.1.3 Parameter settings

Table 6 and Table 8 are derived from Recommendation ITU-R M.1371 and give the parameters required for an AIS AtoN station. For the meaning of the symbols and additional information (footnotes), refer to the appropriate section of Recommendation ITU-R M.1371.

Table 6 – Required parameter settings for an AIS AtoN Station

Symbol	Parameter name	Setting (FATDMA, RATDMA)	Setting (CSTDMA)
PH.RFR	Regional frequencies	Two channels between 156,025 MHz and 162,025 MHz	
PH.AIS1	Channel 1 (default channel 1)	161,975 MHz	
PH.AIS2	Channel 2 (default channel 2)	162,025 MHz	
PH.BR	Bit rate	9 600 bps	
PH.TS	Training sequence	24 bits	
PH.TST	Transmitter settling time (transmit power within 20 % of final value. Frequency stable to within $\pm 1,0$ kHz of final value). Tested at manufacturers declared transmit power	$\leq 1,0$ ms	≤ 313 μ s
	Ramp down time	≤ 832 μ s	≤ 313 μ s
	Transmission duration	≤ 80 ms	$\leq 23\,333$ μ s
	Transmission delay	No delay	2 083 μ s
	Transmitter output power	12,5 W or as defined by manufacturer	

In addition, the constants of the physical layer of the AIS AtoN station shall comply with the values given in Table 7 and Table 8.

Table 7 – Required settings of physical layer constants

Symbol	Parameter name	Value
PH.DE	Data encoding	NRZI
PH.FEC	Forward error correction	Not used
PH.IL	Interleaving	Not used
PH.BS	Bit scrambling	Not used
PH.MOD	Modulation	Bandwidth adapted GMSK

Table 8 – Modulation parameters of the physical layer of the AIS AtoN station

Symbol	Name	Value
PH.TXBT	Transmit BT-product	0,4
PH.RXBT	Receive BT-product	0,5
PH.MI	Modulation index	0,5

5.1.1.4 Transmitter shutdown

An automatic transmitter shutdown shall be provided to ensure that transmission does not continue for more than 2 s. This shutdown shall be independent of any software.

5.1.1.5 Transmitter characteristics

The technical characteristics as specified in Table 9 should apply to the TDMA transmitter.

Table 9 – Minimum required TDMA transmitter characteristics

Transmitter parameters	Requirements
Carrier power error	$\pm 1,5$ dB (normal), ± 3 dB (extreme)
Carrier frequency error	± 500 Hz (normal), ± 1000 Hz (extreme)
Slotted modulation mask	-25 dBc $\Delta f_c < \pm 10$ kHz -60 dBc ± 25 kHz $< \Delta f_c < \pm 62,5$ kHz
Transmitter test sequence and modulation accuracy	< 3400 Hz for bit 0, 1 (normal and extreme) 2400 Hz ± 480 Hz for bits 2, 3 (normal and extreme) 2400 Hz ± 240 Hz for bits 4... 31 (normal, 2400 Hz ± 480 Hz extreme) For bits 32 ...199 1740 Hz ± 175 Hz (normal, 1740 Hz ± 350 Hz extreme) for a bit pattern of 0101 2400 Hz ± 240 Hz (normal, 2400 Hz ± 350 Hz extreme) for a bit pattern of 00001111
Transmitter output power versus time	Power within mask shown in Figure 5 and timings given in Table 12
Spurious emissions	-36 dBm 9 kHz... 1 GHz -30 dBm 1 GHz... 4 GHz

5.1.2 Receiver requirements

The technical characteristics as specified in Table 10 should apply to the TDMA receivers.

Table 10 – Required receiver characteristics

Receiver parameters	Required result (Max PER or absolute level in dBm)	Type 3 (TDMA receiver)		Type 2 (control receiver)	
		Wanted signal	Unwanted signals	Wanted signals	Unwanted signals
Sensitivity	20%	-107 dBm normal -104 dBm normal at ± 500 Hz offset -101 dBm extreme	-	-97 dBm normal -94 dBm normal at ± 500 Hz offset -91 dBm extreme	-
Error at high input levels	2% 10%	-77 dBm -7 dBm	- -	-77 dBm -7 dBm	- -
Co-channel rejection	20%	-101 dBm	-111 dBm -111 dBm at $\pm 1\,000$ Hz offset	-91 dBm	-107 dBm -107 dBm at $\pm 1\,000$ Hz offset
Adjacent channel selectivity	20%	-101 dBm	-31 dBm	-91 dBm	-31 dBm
Spurious response rejection	20%	-101 dBm	-31 dBm	-91 dBm	-31 dBm
Intermodulation response rejection	20%	-101 dBm	-36 dBm	-91 dBm	-36 dBm
Blocking and desensitisation	20%	-101 dBm	-23 dBm (< 5 MHz) -15 dBm (> 5 MHz)	-91 dBm	-33 dBm (< 5 MHz) -25 dBm (> 5 MHz)
Spurious emissions	-57 dBm or less (9 kHz-1 GHz) -47 dBm or less (1 GHz-4 GHz)	-	-	-	-

5.1.3 Power consumption

The manufacturer shall state the average power consumed by the AIS AtoN station under defined test conditions.

5.1.4 Environmental requirements

The manufacturer shall declare the category for durability and resistance to environmental conditions (e.g. durability and resistance to environment, electromagnetic emissions, and immunity to electromagnetic environment) for the EUT as specified in IEC 60945.

5.2 Link layer

5.2.1 General

The link layer specifies how data shall be formatted and transmitted on the VDL.

The link layer requirements are referenced to Recommendation ITU-R M.1371.

5.2.2 AIS Messages

5.2.2.1 Message 21 format and content

5.2.2.1.1 AtoN status bits

The AIS AtoN station shall broadcast Message 21, as defined in Recommendation ITU-R M.1371. In Message 21, the status bits (7 6 5 4 3 2 1 0) are numbered so that bit 7 is the most significant bit, and bit 0 is the least significant bit. The first three bits (i.e. 7, 6 and 5) shall be used to define a page ID. The page ID can range from 0 to 7, allowing 8 pages. Page ID 0 shall not be used for the regional/international application.

Annex B defines AtoN status bit pages.

5.2.2.1.2 Virtual and Synthetic AIS AtoN message

An AIS AtoN station, when broadcasting Message 21 for virtual and synthetic AtoN, shall use the MMSIs allocated to the virtual and synthetic AtoN as issued under the same series for real AIS AtoN stations. For synthetic AIS AtoN messages, the repeat indicator field shall be set to 1 to signify that the message is transmitted from a position other than that provided in the message. All parameters of all virtual and synthetic AIS AtoN messages shall be configurable.

5.2.2.2 Additional messages

In addition to Message 21, the AIS AtoN station may transmit other messages, in accordance with Recommendation ITU-R M.1371. These are summarised in Table 2.

5.2.3 Synchronisation

5.2.3.1 General

Synchronisation is used to determine the TDMA frames and individual slots so that the transmission of the AIS message is performed within the desired slot. The synchronisation for the AtoN AIS station shall be UTC direct.

If UTC direct synchronisation is lost, the AIS AtoN station shall cease transmitting or optionally behave as declared by the manufacturer.

5.2.3.2 Optional indirect synchronisation

When UTC synchronisation has failed, the type 3 AIS AtoN station may use indirect synchronisation or synchronise to a station acting as a semaphore.

5.2.3.3 Synchronisation accuracy

The transmission timing error, including jitter, of the AtoN AIS shall be within the limits as defined in Table 11, referring to an ideal transmission as defined by Recommendation ITU-R M.1371.

Table 11 – Maximum allowed time error

Synchronisation mode	Maximum allowed time error
UTC direct synchronisation	± 1 bit ($\pm 104 \mu\text{s}$)
UTC indirect synchronisation	± 3 bits ($\pm 312 \mu\text{s}$)
Semaphore synchronisation	± 3 bits ($\pm 312 \mu\text{s}$)

5.2.4 VDL access schemes

5.2.4.1 General

The AIS AtoN station shall use FATDMA (or RATDMA only for Type 3) for the transmission of Message 21.

The AIS AtoN station may optionally transmit Messages 6, 7, 8, 12, 13, 14, 25 and 26. The maximum length of Messages 6, 8, 12, and 14 is three slots per message when using FATDMA or RATDMA (if implemented). CSTDMA may be used for one-slot messages only.

To ensure a consistent slot range, the message transmission slot interval valid range is 375 to 3240 000 slots. The interval shall evenly divide a minute, hour, or day, and shall be an integer number of slots. This results in the following valid intervals:

- seconds: 10,12, 20, 30;
- minutes: 1, 2, 3, 4, 5, 6,10,12,15, 20, 30;
- hours: 1, 2, 3, 4, 6, 8,12, 24.

5.2.4.2 Type 3 AIS AtoN station

The type 3 AIS AtoN station shall use FATDMA and may use RATDMA (if implemented) for Message 21. The type 3 AIS AtoN station shall use the VDL access scheme defined by its configuration.

Single slot binary and safety-related messages may be transmitted using FATDMA, RATDMA or CSTDMA, if implemented. When enabled, acknowledgement Messages 7 and 13 shall be transmitted within 4 s of receiving Messages 6 and 12 using FATDMA, CSTDMA or RATDMA. When acknowledgement is enabled, transmission of Messages 6 and 12 shall be repeated if no acknowledgment is received within 4 s of each transmission (up to 3 times).

5.2.4.3 FATDMA VDL access

Slot reservations made by Message 20 shall be ignored when scheduling an FATDMA transmission, since the base station may be reserving them for use by the AIS AtoN station.

5.2.4.4 RATDMA VDL Access

RATDMA shall use slots according to Recommendation ITU-R M.1371.

The AtoN shall monitor the VDL for a minimum of 1 min before RATDMA transmission.

When receivers are not operating continuously, slots reserved by a received Message 20 shall be observed with an extended time out of between 12 h and 24 h. Additionally receivers shall be turned on for 7 consecutive minutes at power on and at least once per 12 h period to allow latest FATDMA reservations to be captured.

The start slot defines the first slot of the RATDMA selection interval. If the start slot is not defined, then it is randomly selected, which is the default behaviour when scheduling transmissions using RATDMA.

5.2.4.5 FATDMA and RATDMA VDL access

5.2.4.5.1 Transmission timing

The transmitter shall begin transmission by turning on the RF power after slot start (T_0). The unit shall and reach -3 dB before T_{B1} (see Figure 5).

The transmitter shall be turned off after the last bit of the transmission packet has left the transmitting unit; nominal transmission end is T_e .

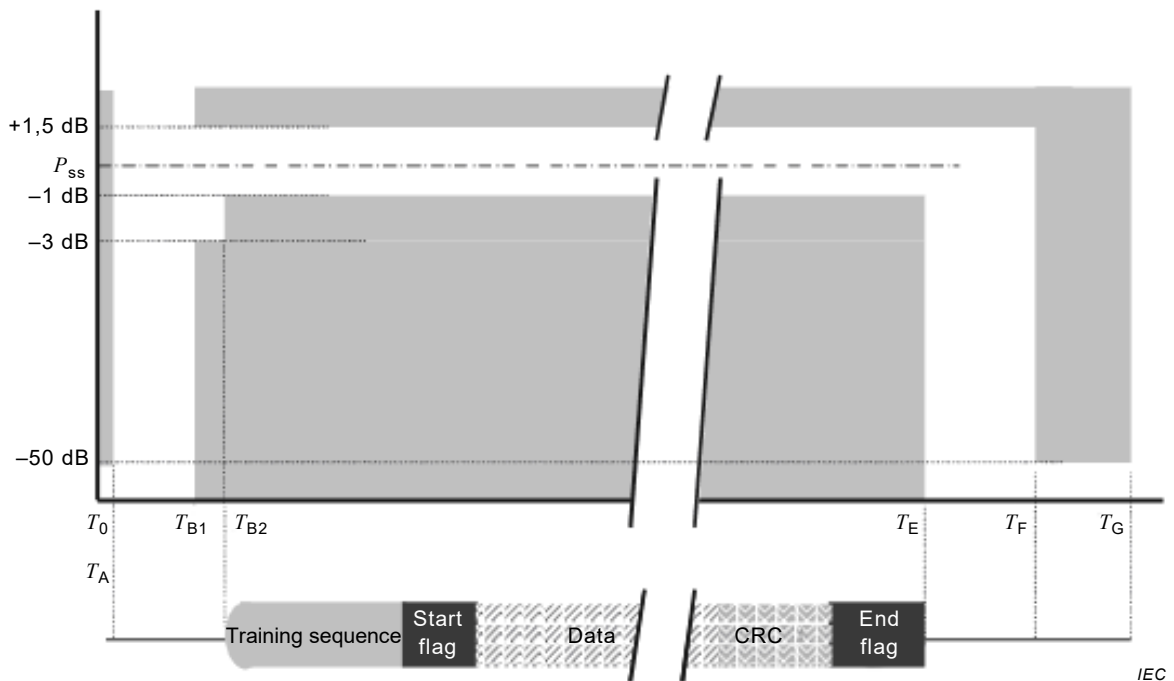

Figure 5 – Power versus time mask

The access to the medium is performed as shown in Figure 5 and Table 12.

Table 12 – Definitions of timing for Figure 5

Reference	Bits	Time in ms	Definition
T_0	0	0	Start of transmission slot. Power shall not exceed -50 dB of P_{ss} before T_0
T_A	0-6	0 – 0,624	Power exceeds -50 dB of P_{ss}
T_B	T_{B1}	6	Power shall be within $+1,5$ dB or -3 dB of P_{ss}
	T_{B2}	8	Power shall be within $+1,5$ dB or -1 dB of P_{ss}
T_E	104 – 748	10,833 – 77,917	Power shall remain within $+1,5$ dB or -1 dB of P_{ss} during the period T_{B2} to T_E The T_E can vary depending on message type, data content and bit stuffing bits from minimum 104 bits for the shortest possible message (Message 14 and no text content) to maximum length of 740 bits for a three-slot message. T_E shall not exceed; <ul style="list-style-type: none"> • 236 bits for a one-slot message • 492 bits for a two-slot message • 748 bits for a three-slot message A station may occupy at maximum three consecutive slots for one continuous transmission. Only a single application of the overhead (ramp up, training sequence, flags, FCS, buffering) is required for a long transmission packet. The length of a long transmission packet should not be longer than necessary to transfer the data; i.e. the AIS should not add filler.
T_F	112 – 756	11,667 – 78,787	Power shall be -50 dB of P_{ss} and stay below this
T_G	256, 512 or 768	26,667 one slot TX 53,333 two slot TX 80,000 three slot TX	Start of next transmission time period

5.2.4.5.2 Link sub-layer 1: medium access control (MAC)

Refer to Recommendation ITU-R M.1371 and 5.2.3 for synchronisation.

5.2.4.5.3 Link sub-layer 2: data link service (DLS)

Refer to Recommendation ITU-R M.1371.

5.2.4.5.4 Link sub-layer 3: link management entity (LME)

Refer to Recommendation ITU-R M.1371.

5.2.4.6 CSTDMA VDL access mode

The operation of CSTDMA in the AIS AtoN station shall be in accordance with Recommendation ITU-R M.1371 and tested according to IEC 62287-1, however the AIS AtoN station is allowed to use the same transmit power setting for CSTDMA as for RATDMA and FATDMA.

All CSTDMA transmissions shall be limited to one slot.

5.2.5 Autonomous mode**5.2.5.1 General**

The AIS AtoN station shall always operate autonomously and determine its own schedule for transmission of its messages based on its configuration. The station shall automatically resolve scheduling conflicts with other stations when using CSTDMA and RATDMA.

5.2.5.2 Message 21 reporting intervals

In accordance with ITU-R M.1371 the default reporting interval for Message 21 shall be 3 min. This shall be configurable to other reporting intervals.

The AIS AtoN station shall be configurable to decrease the reporting interval for Message 21 when the AtoN is off-position.

5.2.5.3 Channel operation

5.2.5.3.1 Reporting modes for Message 21

The AIS AtoN station shall transmit Message 21 at the configured reporting interval. As indicated in Figure 6, transmissions shall be:

- Mode A operation: Message 21 transmission alternates between channel 1 and channel 2 in a subsequent frame that is nominally one reporting interval later. Message 21 content is updated for each message, or
- Mode B operation: the same Message 21 transmitted on channel 1 and channel 2 in quick (nominally 4 s) succession. The first transmission of each Message 21 may be on either channel 1 or channel 2. The second transmission shall be on the other channel, or
- Mode C operation: Message 21 transmitted on a single channel, either channel 1 or channel 2. Message 21 content updated at each reporting interval.

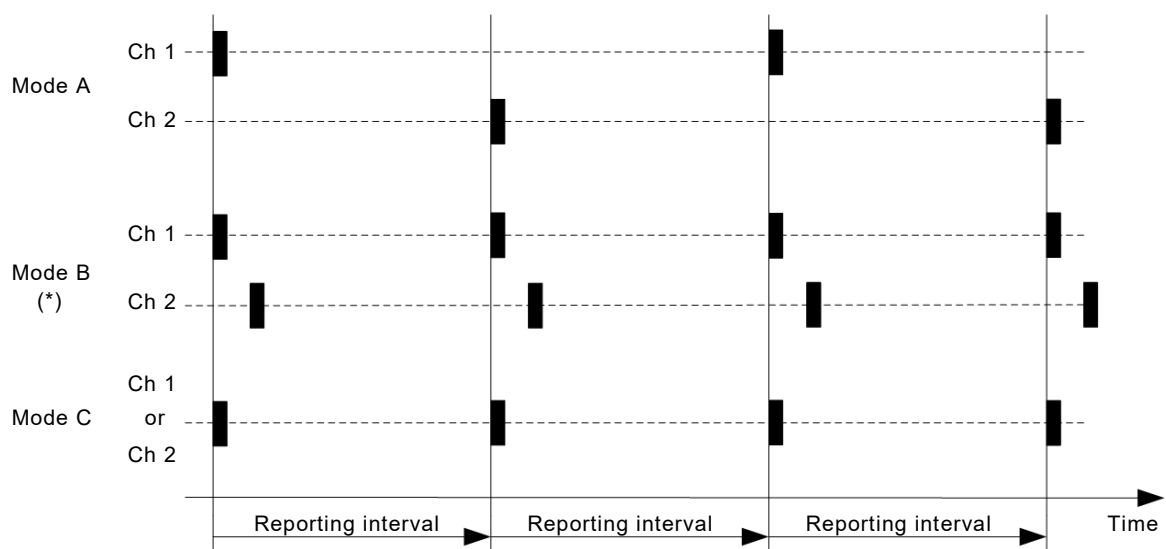

(*) Mode B may start on Ch 1 or Ch 2

Each  represents transmission of Message 21

IEC

Figure 6 – Reporting modes for Message 21

5.2.5.3.2 Single channel operation for Message 21

The type 1 and type 2 AIS AtoN stations shall transmit on the designated channel using FATDMA slots of the selected frames in the UTC hour (as per mode C, Figure 6).

5.2.6 Electronic position fix system

5.2.6.1 Position source

An EPFS shall be used as the source for AtoN position reporting unless a surveyed position is used.

If the internal EPFS is a GNSS receiver, it shall meet the following requirements of the IEC 61108 series: position accuracy, acquisition, re-acquisition, receiver sensitivity, RF dynamic range, interference susceptibility, position update, failure warnings, status indications and integrity flag, provide a resolution of one ten-thousandth of a minute of arc and use WGS 84 datum.

If another type of EPFS is used, then it shall meet the requirements of the applicable standard and use WGS 84 datum.

5.2.6.2 Augmentation systems

The EPFS may be capable of being corrected using any suitable augmentation system (for example, SBAS, radio beacon DGNSS, evaluation of Message 17, etc.). The manufacturer shall declare which augmentation systems can be used, and that the augmentation system does not adversely affect Message 21 transmissions.

The manufacturer shall declare if the EPFS is not capable of being corrected.

5.2.6.3 Invalid position

If the EPFS device is unable to provide a valid position fix, then the reported position shall be longitude = 181° = not available = default and latitude = 91° = not available = default and the time stamp field shall be set to a value of 63.

5.2.6.4 Off-position monitoring

If the floating AtoN is within its on-position limits, the off-position indicator shall be set to “0” in the transmitted Message 21.

If a floating AtoN is off-position, the AIS AtoN station shall identify this condition and the off-position indicator shall be set to “1” in the transmitted Message 21. The reporting interval when the AIS AtoN station is off-position shall be determined by its configuration (see 5.2.5.2).

5.2.6.5 Position source alternatives for types 1, 2 and 3

If a surveyed position is used, an EPFS is not required.

When a surveyed position is used, the latitude and longitude fields of the transmitted Message 21 shall contain the surveyed position, the “type of electronic position fixing device” is set to “7” (surveyed), the “RAIM-Flag” field is set to “0”, the off-position indicator field is set to “0” and the “position accuracy” field is set in accordance with the accuracy of the surveyed position (i.e. “1” if better than 10 m, otherwise “0”).

5.2.7 Built-in integrity test

The AIS AtoN station shall have a built-in integrity test (BIIT) process which tests for conditions as described in Table 13. If standard configuration sentences are used, the warning/notification conditions shall be sent via sentence ADS. The manufacturer may optionally output an ALR sentence using the alarm ID defined in Table 13.

The health flag in the AtoN status bits defined in Annex A shall be set if any of the BIIT conditions in Table 13 are detected.

Table 13 – AIS AtoN Station reaction to BIIT conditions

Alarm ID	Condition	Reaction of the AIS AtoN station
001	AIS: Tx malfunction	Stop transmission
002	AIS: antenna VSWR exceeds limit	Continue operation
003	AIS: Rx Channel 1 malfunction	Stop RATDMA and CSTDMA transmissions on affected channel
004	AIS: Rx Channel 2 malfunction	Stop RATDMA and CSTDMA transmissions on affected channel
006	AIS: general failure	Stop transmission
007	AIS: direct synchronisation failure	As defined by manufacturer
026	AIS: EPFS failure	Continue operation
037	AIS: synchronisation lost	As defined by manufacturer
038	AIS: DGNSS input failed	Continue operation

5.3 Configuration method

5.3.1 General

The configuration method shall be as defined by the manufacturer and held in non-volatile memory.

Configuration may use standard configuration sentences either directly or via the VDL. Query for the encryption key is not allowed. The configuration method shall:

- configure the content for Message 21;
- configure transmission parameters for Message 21 and any other messages supported by the manufacturer;
- configure the behaviour of the AIS AtoN station when synchronisation is lost;
- configure the behaviour of the AIS AtoN station when off position.

The manufacturer shall provide a means to verify configuration and version information of the AIS AtoN station.

5.3.2 Alternative for types 1, 2 and 3

5.3.2.1 General

Standard PI sentences Table 14 provides an overview of the sentences that may be used for configuration of AIS AtoN applications. It includes sentences from IEC 61162-1 and AIS AtoN specific sentences given in NMEA 0183:June 2012.

These standard sentences shall be implemented to provide at least one standard method for configuration. Sentences which support an optional, not implemented, function are not required.

It is possible to implement these sentences using a separate interface unit that communicates with the AtoN unit with a proprietary communication method.

Table 14 – Standard sentences

Sentence Formatter	Input			NAK required with Invalid Input	Output			Description / Comments
	Type 1	Type 2	Type 3		Type 1	Type 2	Type 3	
ABK					X	X	X	Acknowledgement message
ABM	X	X	X	N				Addressed binary message
ACF	X	X	X	Y	Q	Q	Q	General AIS AtoN station configuration
ACG (ACE) ^c	X	X	X	Y	Q	Q	Q	Extended general AIS AtoN station configuration
AFB ^a	X	X	X	Y				Force broadcast
AID	X	X	X	Y	Q	Q	Q	Configure or change MMSI
BBM	X	X	X	N				Broadcast binary message
CBR ^{a,b} (AAR) ^c	X	X	X	Y	Q	Q	Q	Configure broadcast rates for AIS AtoN station messages.
CEK (AKE) ^c		X	X	Y				Define encryption key
COP (ARW) ^c		X	X	Y		Q	Q	Receiver turn on times
DCR (AFC) ^c				Y	Q	Q	Q	AtoN station function capability (see Table 15)
FSR						X	X	Optional
MEB ^a (MPR) ^c	X	X	X	Y				Message payload rebroadcast
NAK					X	X	X	Output when a command fails to execute
SPO		X	X	Y		Q	Q	Optional
VDM						X	X	VHF data link message
VDO					X	X	X	VHF data-link own-vessel message
VER				Y	Q	Q	Q	Version
VSI						X	X	Optional

X: Indicates input to or output from the AIS AtoN station.

Q: Indicates that the sentence may be externally requested using the IEC 61162-1 standard query method.

^a For Message ID index within the AFB, CBR, and MEB sentences, the following interpretation applies: for normal schedules a Message Id Index of 1... 7 shall be used and 0 shall be used for special cases like single messages.

^b CBR uses slots for the definition of the RATDMA slot interval in place of seconds.

^c Sentence formatters in parenthesis are legacy sentences which performed a similar function but should not be used for new designs (See NMEA 0183:June 2012).

Table 15 – DCR Capabilities

Bit position	Capability
0	Type 1
1	Type 2
2	Type 3
3	FATDMA
4	RATDMA
5	CSTDMA
6	Direct VDL configuration Message 6
7	Direct VDL configuration Message 25
8	Chaining VDL configuration
9	UTC indirect
10	Message 6/7
11	Message 8
12	Message 12/13
13	Message 14
14	Message 25
15	Message 26
16	Dual Channel
17	Virtual AtoN
18	EPFS
19 – 99	Reserved for future use
100 – 127	Manufacturer defined

COP sentence limitations are as follows:

- Start time = shall be an integer minute value.
- Time interval between periods = shall not be greater than 1 week (604 800 s), shall not be higher resolution than 1 min, and the interval shall evenly divide an hour, day or be an integer number of days; This results in the following valid intervals:
 - minutes: 1, 2, 3, 4, 5, 6,10,12,15, 20, 30;
 - hours: 1, 2, 3, 4, 6, 8,12, 24;
 - day: 1, 2, 3, 4, 5, 6, 7.
- Duration of period = shall be an integer minute value with a maximum of 24 h.

A NAK sentence using reason code 11 shall be generated if a non-conforming parameter is entered with the NAK descriptive text “invalid interval”, and the COP shall be ignored.

5.3.2.2 Optional TAG block sentences

In case of introducing an AIS AtoN station in a shore-based network, the TAG block functions may be used to support station identification, routing of sentences, additional information and grouping of sentences.

The sentences described in Table 16 are used to configure the TAG block functions.

If the TAG blocks are implemented, all functions according to Table 16 shall be supported.

Table 16 – Optional TAG Block functions

Sentence	Associated parameter	Required input function	Required output function
CPC	"c" = Unix time parameter	No evaluation on input required	Output of time tag (current UTC time) with all output sentences, 0 if not available. Required accuracy of ± 1 s.
CPD	"d" = destination-identification	Filtering of input sentences based on own UI (configured by SID sentence)	Output of destination-identification tag in all responses.
CPG ^a	"g" = sentence Grouping	No evaluation required	Grouping of related sentences, VDM and VDO with a VSI sentence and multi-part sentences.
CPN ^b	"n" = line count	No evaluation required	Output of line count tag with all output sentences.
CPS	"s" = source-identification	Filtering of input sentences based on Source-identifications configured by TBS sentence	Output of Source-identification tag with own UI attached to NAK responses or to all output sentences.
TBR	TAG block report request	Response with at least CPD, CPG, CPS, CPC, CPN	No TBR output.
TBS	"s" = Source-identification	Configuration of at least 5 different Source-identifications for input filtering	Response on query for TBS.
^a The minimum required: group-code increment = 1. The reset event = 0. Initial group code = 1. Group code limit = 1 – 999 999 999. ^b The minimum required: count Increment = 1. The reset event = 0. Initial line-count = 1. Line-count limit = 1 – 999 999 999.			

5.3.3 Chaining of AIS AtoN stations

The AIS AtoN station may support chaining to communicate messages to other AIS AtoN stations (see 4.6).

No additional IEC 61162-1 sentences are required to support this functionality.

5.4 Repeat broadcast of active AIS-SART message

A type 3 AtoN may optionally implement repeat functionality for active AIS-SART messages. When implemented, it shall follow rules set forth in 4.4.3 of IEC 62320-3:2015, which provide for only one message from the active AIS-SART burst to be repeated.

5.5 Other requirements

5.5.1 Additional features

Additional features shall not adversely affect the transmission of Message 21.

5.5.2 Manufacturer's information

The information shall describe:

- external interfaces;
- configuration of the AIS AtoN station;
- hardware and electrical specifications;
- average power consumption;
- implementation method for firmware upgrades.

5.5.3 Marking and identification

The AIS AtoN station shall be marked with the following information:

- identification of the manufacturer;
- model identification;
- serial number of the unit; and
- operating voltage.

The title and version of each software element included in the installed software system shall be either marked on the equipment or output on request using the VER sentence.

5.5.4 Additional connection points

5.5.4.1 Protection

The number of connection points (USB ports, disc drives, wireless connection, etc.) shall be limited to the absolute minimum required specified by the manufacturer for operation, lifetime maintenance and support. All superfluous other points shall be blocked e.g. by software or physically disabled.

5.5.4.2 Executable program file verification

Execution of any type of files from external data sources shall only be possible after passing an authentication process as defined by the manufacturer before accessing executable content.

6 Tests of AIS AtoN stations

6.1 General

Physical test parameters and testing subject to national requirements may override parameters stated below.

6.2 Test conditions

6.2.1 Normal test conditions

6.2.1.1 Temperature and humidity

Temperature and humidity shall be within following ranges:

Temperature +15 °C to +35 °C

Humidity 20 % to 75 %

6.2.1.2 Power supply

The normal supply power used for the tests shall be in accordance with the nominal power of the EUT declared by the manufacturer and taking into account the variations set by local safety regulations concerning power supplies, for example IEC 60950, as applicable in many countries.

6.2.2 Extreme test conditions

Extreme test conditions are as specified in IEC 60945. Where required, tests under extreme test conditions shall be a combination of:

- dry heat and the upper limit of supply voltage applied simultaneously; and
- low temperature and the lower limit of supply voltage applied simultaneously.

6.2.3 Standard test environment

The EUT is tested in an environment using test equipment to measure the transmitted messages. The EUT will be configured via the configuration interface prior to the tests. Operation is checked on channels in the maritime mobile band. Refer to Figure 7.

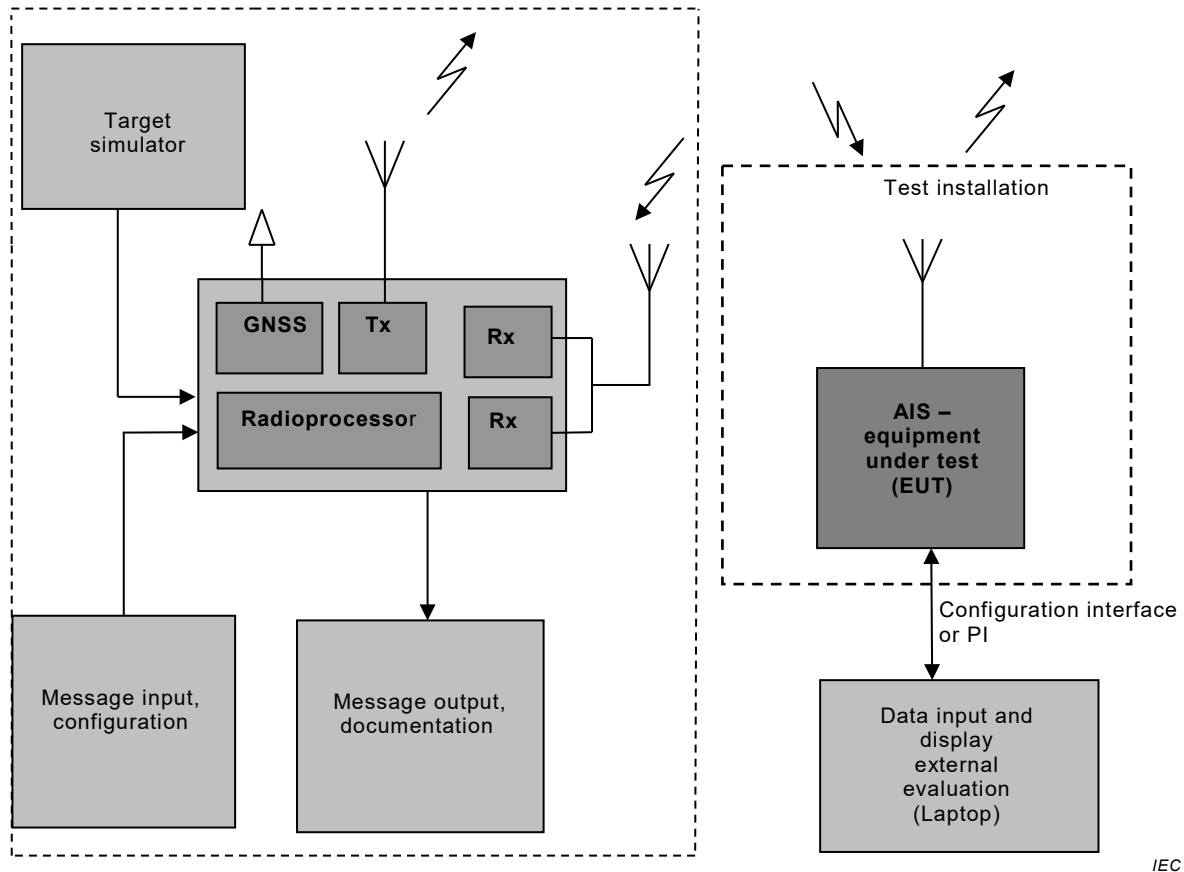

IEC

Figure 7 – Block diagram of AIS AtoN test setup

6.2.4 Test signals

6.2.4.1 Standard test signal number 1

A series of 010101 as the data within an AIS message frame, with header, start flag, end flag and CRC. NRZI is not applied to the 010101 bit stream or CRC (i.e. unaltered "On Air" data). The RF should be ramped up and down on either end of the AIS message frame.

6.2.4.2 Standard test signal number 2

A series of 00001111 as the data within an AIS message frame, with header, start flag, end flag and CRC. NRZI is not applied to the 00001111 bit stream or CRC. The RF should be ramped up and down on either end of the AIS message frame.

When transmitters have limitations concerning their maximum continuous transmit time and/or their transmission duty cycle, such limitations should be respected during testing.

6.2.4.3 Standard test signal number 3

A pseudo random sequence (PRS) as specified in Recommendation ITU-T O.153 as the data within an AIS message frame with header, start flag, end flag and CRC. NRZI is not applied to

the PRS stream or CRC. The RF should be ramped up and down on either end of the AIS message frame.

6.2.4.4 Standard test signal number 4

This test signal consists of 200 packets grouped into clusters of 4 as described in Figure 8. Each cluster consists of 2 consecutive transmissions of the packets described in Table 17.

NRZI shall be applied to every packet. After sending packets 1 and 2, the notional initial state of the NRZI process shall be inverted and then packets 1 and 2 repeated.

Between every transmitted packet, there shall be at least 2 free time periods. The RF carrier shall be switched off between packets to simulate normal operation.

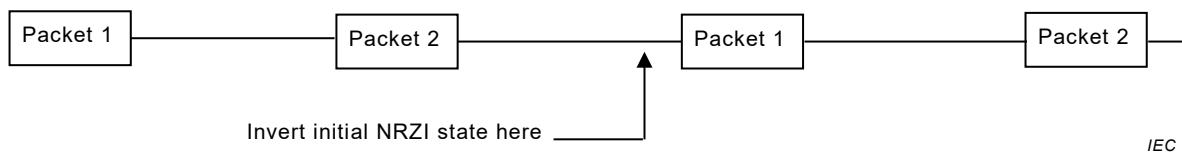

Figure 8 – Format for repeating four-packet cluster

Table 17 – Content of first two packets

Packet	Parameter	Bits	Contents	Comment
1	Training	22	0101....0101	Preamble reduced by 2 bits because of ramp-up overlap
	Start flag	8	01111110	
	Data	168	Pseudo random	As per Table 18
	CRC	16	Calculated	
	End flag	8	01111110	
2	Training	22	1010....1010	Preamble reduced by 2 bits because of ramp-up overlap
	Start flag	8	01111110	
	Data	168	Pseudo random	As per Table 18
	CRC	16	Calculated	
	End flag	8	01111110	

Table 18 – Fixed PRS data derived from ITU-T O.153

Address	Contents (HEX)							
0-7	0x04	0xF6	0xD5	0x8E	0xFB	0x01	0x4C	0xC7
	0000.0100	1111.0110	1101.0101	1000.1110	1111.1011	0000.0001	0100.1100	1100.0111
8-15	0x76	0x1E	0xBC	0x5B	0xE5	0x92	0xA6	0x2F
	0111.0110	0001.1110	1011.1100	0101.1011	1110.0101	1001.0010	1010.0110	0010.1111
16-20	0x53	0xF9	0xD6	0xE7	0xE0	21 bytes = 168 bits (+ 4 stuffed bits), CRC = 0x3B85		
	0101.0011	1111.1001	1101.0110	1110.0111	1110.0000			

6.2.5 Arrangements for test signals applied to the receiver input

Sources of test signals for application to the receiver input shall be connected in such a way that the source impedance presented to the receiver input is 50 Ω.

This requirement shall be met irrespective of whether one or more signals using a combining network are applied to the receiver simultaneously.

The levels of the test signals at the receiver input terminals (RF socket) shall be expressed in terms of dBm.

The effects of any intermodulation products and noise produced in the test signal sources shall be negligible.

6.2.6 Encoder for receiver measurements

Whenever needed and in order to facilitate measurements on the receiver, an encoder for the data system shall accompany the EUT, together with details of the normal modulation process. The encoder is used to modulate a signal generator for use as a test signal source.

Complete details of all codes and code format(s) used shall be given.

6.2.7 Waiver for receivers

If the EUT has two TDMA receivers, and the manufacturer declares that both TDMA receivers are identical, the test may be limited to one receiver and the test for the second receiver may be waived apart from the receiver sensitivity test in 7.2.1.1. The test report shall contain any manufacturer declaration(s).

6.2.8 Impedance

In this standard, the term "50 Ω " is used for a 50 Ω non-reactive impedance.

6.2.9 Artificial antenna (dummy load)

Tests shall be carried out using an artificial antenna, which shall be a non-reactive non-radiating load of 50 Ω connected to the antenna connector.

6.2.10 Facilities for access

All tests shall be performed using the standard port(s) of the EUT, where provided. Where access facilities are required to enable any specific test, these shall be provided by the manufacturer.

6.2.11 Modes of operation of the transmitter

For the purposes of the measurements according to this standard, there shall be a facility to operate the transmitter unmodulated.

Alternatively, the method of obtaining an unmodulated carrier or special types of modulation patterns may also be decided by agreement between the manufacturer and the test laboratory. It shall be described in the test report. It may involve suitable temporary internal modifications of the equipment under test.

6.2.12 Measurement uncertainties

Maximum values of absolute measurement uncertainties shall be as indicated in Table 19.

Table 19 – Maximum values of absolute measurement uncertainties

Parameter	Maximum value
RF frequency	$\pm 1 \times 10^{-7}$
RF power	$\pm 0,75$ dB
Adjacent channel power	± 5 dB
Conducted spurious emission of transmitter	± 4 dB
Conducted spurious emission of receiver	± 3 dB
Two-signal measurement	± 4 dB
Three-signal measurement	± 3 dB
Radiated emission of transmitter	± 6 dB
Radiated emission of receiver	± 6 dB
Transmitter attack time	± 20 %
Transmitter release time	± 20 %
Transmitter transient frequency (frequency difference)	± 250 Hz

For the test methods according to this standard, these uncertainty figures are valid to a confidence level of 95 %.

The interpretation of the results recorded in a test report for the measurements described in this standard shall be as follows:

- the measured value related to the corresponding limit shall be used to decide whether an equipment meets the requirements of this standard;
- the actual measurement uncertainty of the test laboratory carrying out the measurements, for each particular measurement, shall be included in the test report;
- the values of the actual measurement uncertainty shall be, for each measurement, equal to or lower than the figures given in this clause (absolute measurement uncertainties).

7 RF tests

7.1 TDMA transmitter

7.1.1 General

Unless otherwise stated, all transmitter tests shall be performed at the highest power setting.

7.1.2 Frequency error

7.1.2.1 Purpose

The frequency error of the transmitter is the difference between the measured carrier frequency in the absence of modulation and its required frequency.

7.1.2.2 Method of measurement

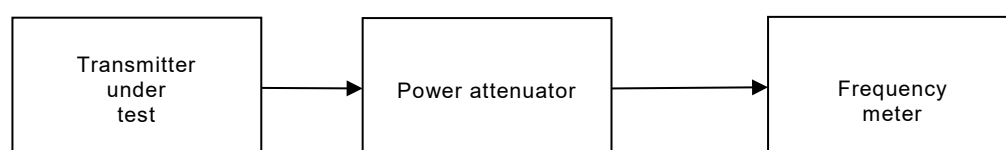

IEC

Figure 9 – Measurement arrangement for frequency error

The measurement procedure shall be as follows:

- a) the equipment shall be connected as illustrated in Figure 9;
- b) the carrier frequency shall be measured in the absence of modulation;
- c) the measurement shall be made under normal test conditions and extreme test conditions;
- d) the test shall be performed on the lowest operating frequency and the highest operating frequency as declared by the manufacturer.

7.1.2.3 Required results

The frequency error shall not exceed $\pm 0,5$ kHz, under normal test conditions and ± 1 kHz under extreme test conditions.

7.1.3 Carrier power

7.1.3.1 Purpose

The transmitter carrier power conducted (P_c) is the mean power delivered to a nominal 50 Ω load during a radio frequency cycle. The rated power shall be nominally 12,5 W or as declared by the manufacturer. The carrier power accuracy shall be tested at the nominal level of 12,5 W or the level declared by the manufacturer.

7.1.3.2 Method of measurement

The measurement procedure shall be as follows:

- a) the equipment shall be connected as illustrated in Figure 10;
- b) the carrier power shall be measured in the absence of modulation;
- c) the measurement shall be made under normal test conditions and extreme test conditions;
- d) the test shall be performed at the lowest and highest operating frequencies as declared by the manufacturer;
- e) if the manufacturer optionally declares multiple power settings then the carrier power test shall be repeated at those settings at both the lowest and highest operating frequency of the EUT.

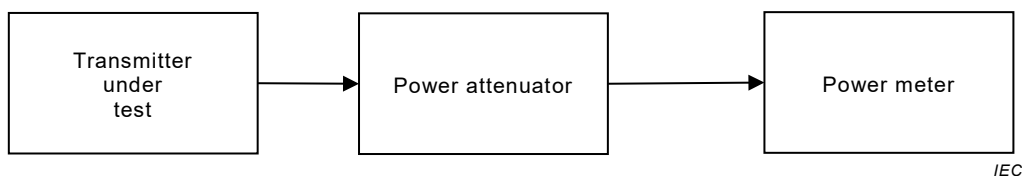

Figure 10 – Measurement arrangement for carrier power

7.1.3.3 Required results

P_c shall be within $\pm 1,5$ dB of the rated nominal power under normal conditions and within ± 3 dB of the rated nominal power under extreme conditions.

7.1.4 Modulation spectrum slotted transmission

7.1.4.1 Purpose

This test is to ensure that the modulation and transient sidebands produced by the transmitter under normal operating conditions fall within the allowable mask.

7.1.4.2 Method of measurement

The measurement procedure shall be as follows:

- a) the test shall use test signal number 3;
- b) the EUT shall be connected to a spectrum analyser. A resolution bandwidth of 1 kHz, video bandwidth of 3 kHz or greater and positive peak detection (maximum hold) shall be used for this measurement. A sufficient number of sweeps shall be used and sufficient transmission packets measured to ensure that the emission profile is developed;
- c) tests shall be performed on the lowest operating frequency on which the EUT can transmit according to the manufacturer's specification and channel 2 (162,025 MHz).

7.1.4.3 Required results

The spectrum for slotted transmission shall be within the emission mask as follows:

- in the region between the carrier and ± 10 kHz removed from the carrier, the modulation and transient sidebands shall be below 0 dBc;
- at ± 10 kHz removed from the carrier, the modulation and transient sidebands shall be below -25 dBc;
- at ± 25 kHz to $\pm 62,5$ kHz removed from the carrier, the modulation and transient sidebands shall be below the lower value of -60 dBc or -30 dBm;
- in the region between ± 10 kHz and ± 25 kHz removed from the carrier, the modulation and transient sidebands shall be below a line specified between these two points.

The reference level for the measurement shall be the carrier power (conducted) recorded for the appropriate test frequency in 7.1.1.2.

For information, the emission mask specified above is shown in Figure 11.

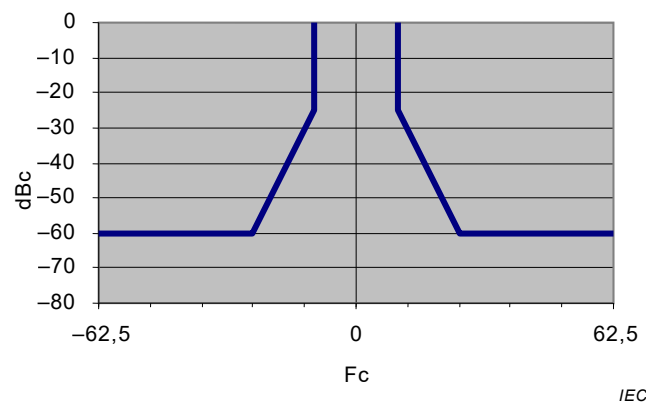

Figure 11 – Emission mask

7.1.5 Transmitter test sequence and modulation accuracy

7.1.5.1 Purpose

The test is to verify that the training sequence starts with a 0 and is a 0101 pattern of 24 bits. The peak frequency deviation is derived from the baseband signal to verify modulation accuracy.

7.1.5.2 Method of measurement

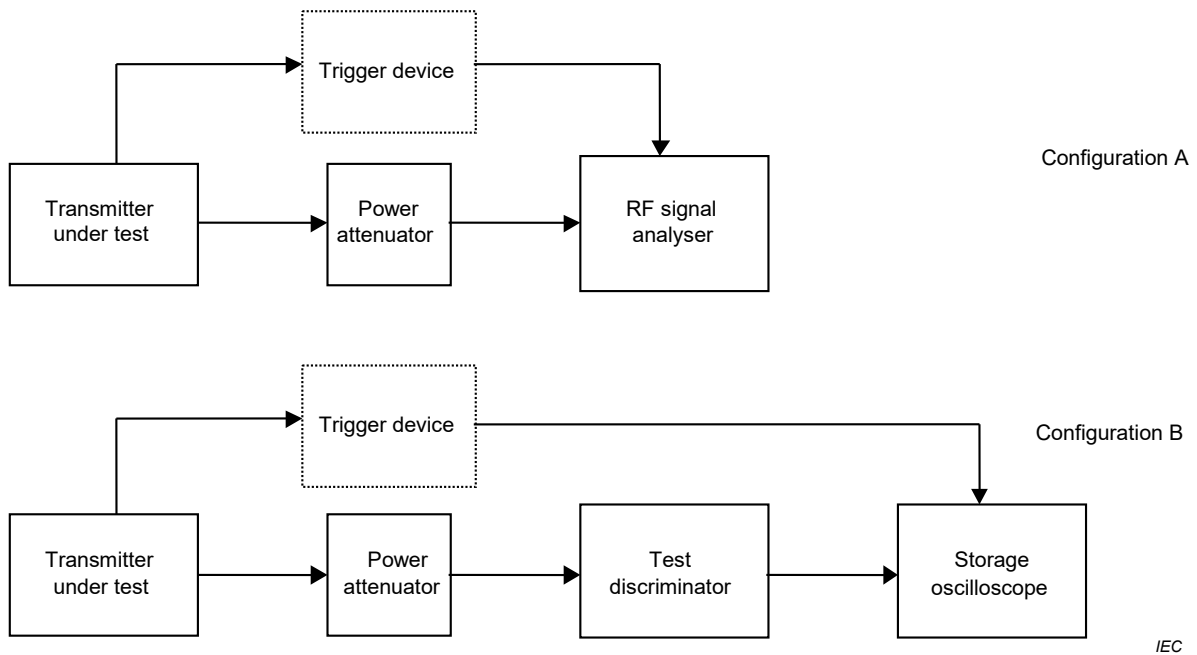

Figure 12 – Measurement arrangement for modulation accuracy

The measurement procedure shall be as follows:

- the equipment shall be connected in either configuration A or configuration B as shown in Figure 12. The trigger device is optional if the equipment is capable of synchronising to the transmitted bursts;
- the transmitter shall be tuned to channel 2 (162,025 MHz);
- the transmitter shall be modulated with test signal number 1;
- the deviation from the carrier frequency shall be measured as a function of time;
- the transmitter shall be modulated with test signal number 2;
- the deviation from the carrier frequency shall be measured as a function of time;
- measurements shall be repeated at the lowest frequency on which the EUT can transmit, according to the manufacturer's specification;
- testing shall be repeated under extreme test conditions.

7.1.5.3 Required results

In each case, verify that the training sequence begins with '0'.

Peak frequency deviation at various points within the data frame shall comply with Table 20. These limits apply to both the positive and negative modulation peaks. Bit 0 is defined as the first bit of the training sequence.

Table 20 – Peak frequency deviation versus time

Measurement period from centre to centre of each bit	Test signal 1		Test signal 2	
	Normal	Extreme	Normal	Extreme
Bit 0 to bit 1	< 3400 Hz			
Bit 2 to bit 3	2400 Hz ± 480 Hz			
Bit 4 to bit 31	2400 Hz ± 240 Hz	2400 Hz ± 480 Hz	2400 Hz ± 240 Hz	2400 Hz ± 480 Hz
Bit 32 to bit 199	1740 Hz ± 175 Hz	1740 Hz ± 350 Hz	2400 Hz ± 240 Hz	2400 Hz ± 480 Hz

7.1.6 Transmitter output power versus time function (FATDMA and RATDMA)

7.1.6.1 Definition

Transmitter output power versus time function is a combination of the transmitter delay, attack time, release time and transmission duration as defined in Table 21 where:

- transmitter delay time ($T_A - T_0$) is the time between the start of the slot and the moment when the transmit power may exceed -50 dB of the steady-state power (P_{ss});
- transmitter attack time ($T_{B2} - T_A$) is the time between the transmit power exceeding -50 dBc and the moment when the transmit power maintains a level within $+1,5$ dB from $-1,0$ dB from P_{ss} ;
- transmitter release time ($T_F - T_E$) is the time between the end flag being transmitted and the moment when the transmitter output power has reduced to a level 50 dB below P_{ss} and remains below this level thereafter.
- transmission duration ($T_F - T_A$) is the time from when power exceeds -50 dBc to when the power returns to and stays below -50 dBc.

Table 21 – Definition of timings

Reference	Bits	Time in ms	Definition
T_0	0	0	Start of transmission slot. Power shall not exceed -50 dB of P_{ss} before T_0
$T_0 - T_A$	0-6	0-0,624	Power may exceed -50 dB of P_{ss} ^a
T_B	T_{B1}	6	Power shall be within $+1,5$ dB or -3 dB of P_{ss} ^a
	T_{B2}	8	Power shall be within $+1,5$ dB or -1 dB of P_{ss} ^a
T_E (includes 1 stuffing bit)	231	24,024	Power shall remain within $+1,5$ dB or -1 dB of P_{ss} during the period T_{B2} to T_E ^a
T_F (includes 1 stuffing bit)	239	26,146	Power shall be -50 dB of P_{ss} and stay below this
T_G	256	26,624	Start of next transmission time period

^a There shall be no modulation of the RF after the termination of transmission (T_E) until the power has reached zero and next slot begins (T_G).

7.1.6.2 Method of measurement

The measurement shall be carried out by transmitting test signal number 1 (note that this test signal generates one additional stuffing bit within its CRC portion).

Tests shall be performed on 2 channels (lowest declared frequency and 162,025 MHz).

The EUT shall be connected to a spectrum analyser.

A resolution bandwidth of 1 MHz, a video bandwidth of 1 MHz and a sample detector shall be used for this measurement.

The analyser shall be in zero-span mode for this measurement. The spectrum analyser shall be synchronised to the nominal start time of the slot (T_0), which may be provided externally, or from the EUT.

7.1.6.3 Required results

The transmitter power shall remain within the mask shown in Figure 5 and associated timings given in Table 21.

7.2 TDMA receivers (types 2 and 3)

7.2.1 Sensitivity

7.2.1.1 Purpose

The maximum usable sensitivity (data or messages, conducted) is the minimum signal level at the receiver input, produced by a carrier at the specified frequency of the receiver, modulated with the specified test signal, which will, without interference, produce a data signal with a specified packet error rate (PER) after demodulation.

7.2.1.2 Method of measurement

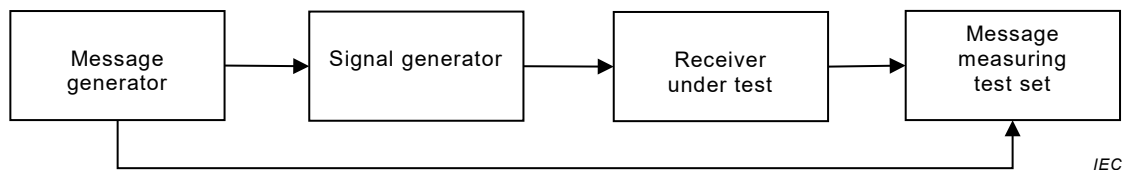

Figure 13 – Measurement arrangement for sensitivity

The measurement procedure shall be as follows with reference to Figure 13:

- the signal generator shall be at the lowest frequency of the receiver as declared by the manufacturer and shall be modulated to generate test signal number 4;
- the signal level at the input of the receiver shall be set to -107 dBm for a type 3 device and -97 dBm for a type 2 device;
- the message measuring test set shall be monitored and the packet error rate observed. The PER shall be derived by the following formula:

$$PER = (P_{TX} - P_{RX})/P_{TX} \times 100 (\%) \quad (1)$$

where

P_{RX} is the number of packets received without errors

P_{TX} is the number of transmitted packets;

- the test shall be repeated at a $+500$ Hz offset from the lowest frequency declared by the manufacturer;
- the test shall be repeated at a -500 Hz offset from the lowest frequency declared by the manufacturer;
- the test shall be at the highest frequency declared by the manufacturer;
- the test shall be repeated at a $+500$ Hz offset from the highest frequency declared by the manufacturer;
- the test shall be repeated at a -500 Hz offset from the highest frequency declared by the manufacturer;

- i) repeat under extreme conditions, at either the lowest or the highest declared frequency. The signal generator shall be adjusted so the level at the input to the receiver is -101 dBm for a type 3 device and -91 dBm for a type 2 device.

7.2.1.3 Required results

Maximum PER of 20 %.

7.2.2 Error behaviour at high input levels

7.2.2.1 Purpose

The error behaviour (performance) at high input levels is defined in the same manner as for the measurement of the maximum usable sensitivity when the level of the wanted signal is 100 dB above the maximum wanted sensitivity.

7.2.2.2 Method of measurement

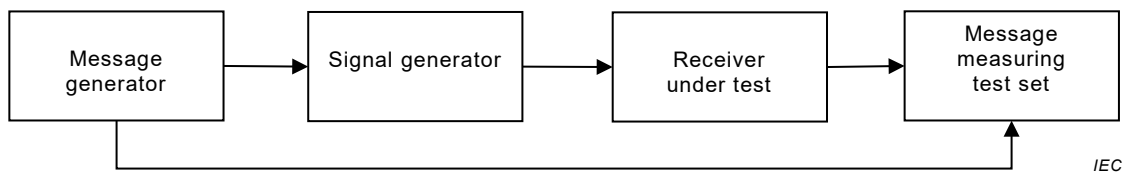

Figure 14 – Measurement arrangement for error behaviour

The measurement procedure shall be as follows:

- the measurement configuration shall be as shown in Figure 14;
- the signal generator shall be modulated to generate test signal number 4. The test shall be carried out at the lowest and the highest TDMA frequencies declared by the manufacturer. The message measuring test set shall be monitored and the packet error rate observed;
- the level of the input signal shall be adjusted to a level of -77 dBm;
- the level of the input signal shall be adjusted to a level of -7 dBm;
- 200 packets shall be transmitted and the PER shall be calculated.

7.2.2.3 Required results

The PER shall not exceed 2 % under c) and 10 % under d).

7.2.3 Co-channel rejection

7.2.3.1 Purpose

The co-channel rejection is a measure of the capability of the receiver to receive a wanted modulated signal without exceeding a given degradation due to the presence of an unwanted modulated signal, both signals being at the specified frequency of the receiver.

7.2.3.2 Method of measurement

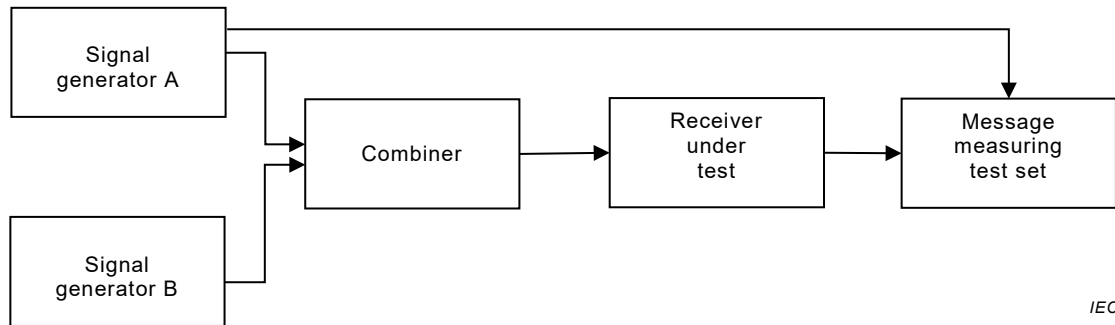

Figure 15 – Measurement arrangement for co-channel rejection

The measurement procedure shall be as follows with reference to Figure 15:

- a) two generators A and B, shall be connected to the receiver via a combining network;
- b) the wanted signal, provided by signal generator A, shall be at the lowest declared frequency of the receiver and shall be modulated to generate test signal number 4;
- c) the unwanted signal, provided by generator B, shall also be at the lowest declared frequency of the receiver. Generator B shall be modulated to generate test signal number 3, either continuously or in the same time period as that used by generator A for test signal number 4. The content of the wanted and unwanted signals shall not be synchronised;
- d) the level of the wanted signal from generator A shall be adjusted to -101 dBm for a Type 3 device and to -101 dBm for a type 2 device;
- e) the level of the unwanted signal from generator B shall be adjusted to -111 dBm for a Type 3 device and -117 dBm for a type 2 device;
- f) the message measuring test set shall be monitored and the packet error rate (PER) observed;
- g) the test shall be repeated at $+1000$ Hz offset from the lowest frequency declared by the manufacturer;
- h) the test shall be repeated at -1000 Hz offset from the lowest frequency declared by the manufacturer;
- i) the test shall be repeated at the highest declared frequency of the receiver;
- j) the test shall be repeated at $+1000$ Hz offset from the highest frequency declared by the manufacturer;
- k) the test shall be repeated at -1000 Hz offset from the highest frequency declared by the manufacturer.

7.2.3.3 Required results

The PER shall not exceed 20 %.

7.2.4 Adjacent channel selectivity

7.2.4.1 Purpose

The adjacent channel selectivity is a measure of the capability of the receiver to receive a wanted modulated signal without exceeding a given degradation due to the presence of an unwanted signal which differs in frequency from the wanted signal by an amount equal to the adjacent channel separation for which the equipment is intended.

7.2.4.2 Method of measurement

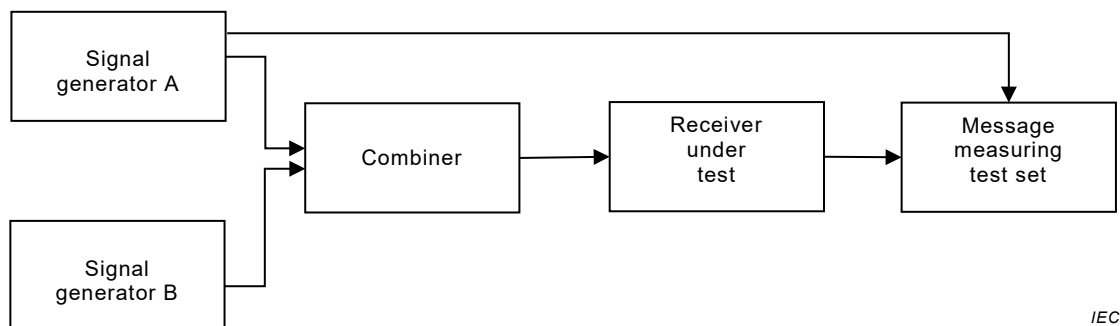

IEC

Figure 16 – Measurement arrangement for adjacent channel selectivity

The measurement procedure shall be as follows with reference to Figure 16:

- a) two generators A and B shall be connected to the receiver via a combining network;
- b) the wanted signal, provided by signal generator A, shall be at the lowest declared frequency of the receiver and shall be modulated to generate test signal number 4;
- c) the unwanted signal, provided by generator B, shall be frequency modulated with a 400 Hz sine wave with a deviation of ± 3 kHz. Generator B shall be at a frequency 25 kHz above that of the wanted signal;
- d) the level of the wanted signal from generator A shall be adjusted to a level of -101 dBm for a type 3 device and to -101 dBm for a type 2 device;
- e) the level of the unwanted signal from generator B shall be adjusted to -31 dBm for a type 3 receiver and -41 dBm for a type 2 receiver;
- f) the message measuring test set shall be monitored and the packet error rate observed;
- g) repeat the above measurement with the unwanted signal 25 kHz below the wanted signal;
- h) the test shall be repeated, steps b) through g), at the highest TDMA frequency declared by the manufacturer.

7.2.4.3 Required results

The PER shall not exceed 20 %.

7.2.5 Spurious response rejection

7.2.5.1 Purpose

The spurious response rejection is a measure of the capability of the receiver to receive a wanted modulated signal without exceeding a given degradation due to the presence of an unwanted modulated signal at any other frequency, at which a response is obtained.

7.2.5.2 Manufacturers' declarations

The manufacturer shall declare the following in order to calculate the "limited frequency range" over which the initial part of the test will be performed:

- a) list of intermediate frequencies: IF_1, IF_2, \dots, IF_N in Hz;
- b) switching range of the receiver: sr ;

NOTE Switching range corresponds to the frequency range over which the receiver can be tuned.

- c) frequency of the local oscillator at channel 2 and at the lowest TDMA channel: f_{LOH}, f_{LOL} .

NOTE Examples of local oscillators are VCO, crystal, sampling clock, BFO, numerically controlled oscillator depending on the design of the equipment.

7.2.5.3 Introduction to the method of measurement

The initial evaluation of the unit shall be performed over the “limited frequency range” and shall then be performed at the frequencies identified from this test and at “specific frequencies of interest” (as defined below).

To determine the frequencies at which spurious responses can occur the following calculations shall be made:

- a) calculation of the "limited frequency range":

the limits of the limited frequency range (LFR_{HI} LFR_{LO}) are determined from the following calculations:

$$LFR_{HI} = f_{LOH} + (IF_1 + IF_2 + \dots + IF_N + sr/2) \quad (2)$$

$$LFR_{LO} = f_{LOL} - (IF_1 + IF_2 + \dots + IF_N + sr/2) \quad (3)$$

- b) calculation of specific frequencies of interest (SFI) outside the limited frequency range:

these are determined by the following calculations:

$$SFI_1 = (K \times f_{LOH}) + IF_1 \quad (4)$$

$$SFI_2 = (K \times f_{LOL}) - IF_1 \quad (5)$$

where K is an integer from 2 to 4.

7.2.5.4 Method of measurement over the limited frequency range

Two methods are available for the measurements over the limited frequency range, one based on SINAD measurements and the other based on PER measurements. Either method may be used, but in each case shall be followed by the method of measurement at identified frequencies.

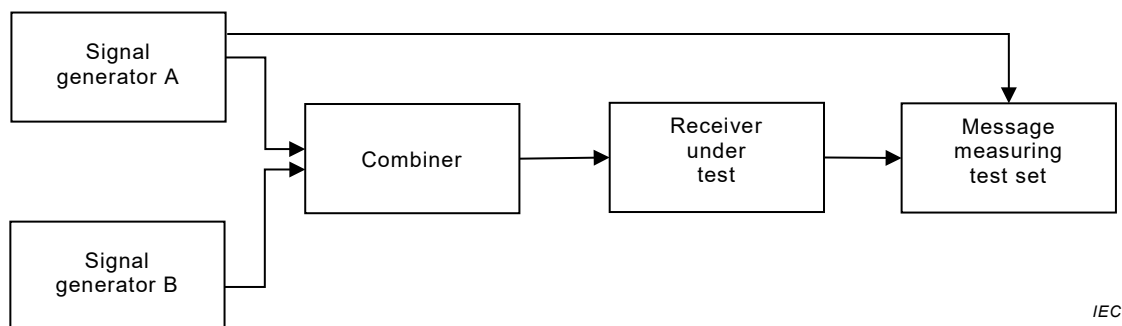

Figure 17 – PER/BER or SINAD measuring equipment

7.2.5.5 Method of search over the "limited frequency range" using SINAD measurement

The measurement procedure shall be as follows with reference to Figure 17:

- two generators A and B shall be connected to the receiver via a combining network;
- the wanted signal, provided by generator A, shall be at 161,975 MHz and shall be modulated with a 1 kHz sine wave at $\pm 2,4$ kHz deviation;
- the unwanted signal, provided by generator B, shall be frequency modulated with a 400 Hz sine wave giving a deviation of ± 3 kHz;

- d) initially, generator B (unwanted) shall be switched off (maintaining the output impedance);
- e) the signal level from generator A (wanted) shall be adjusted to -101 dBm for Type 3 or -91 dBm for type 2 at the receiver;
- f) the SINAD value shall be noted (and shall be greater than 14 dB);
- g) signal generator B shall be switched on and adjusted to -31 dBm at the receiver;
- h) the frequency of the unwanted signal shall be varied in steps of 5 kHz over the limited frequency range (from LFR_{LO} to LFR_{HI});
- i) the frequency of any spurious response detected (by a decrease in SINAD of 3 dB or more) during the search shall be recorded for use in the next measurement.

If the manufacturer's specified receiver frequencies do not include 161,975 MHz, one of the manufacturer's specified receiver frequencies may be used as an alternative.

7.2.5.6 Method of search over the "limited frequency range" using PER or BER measurement

The measurement procedure shall be as follows with reference to Figure 17:

- a) two generators A and B shall be connected to the receiver via a combining network;
- b) the wanted signal, provided by generator A, shall be at 161,975 MHz and shall be modulated to generate test signal number 3;
- c) the unwanted signal, provided by generator B, shall be frequency modulated with a 400 Hz sine wave giving a deviation of ± 3 kHz;
- d) initially, generator B (unwanted) shall be switched off (maintaining the output impedance);
- e) the signal level from generator A (wanted) shall be adjusted to -101 dBm for type 3 or -91 dBm for type 2 at the receiver;
- f) the PER or BER shall be noted;
- g) signal generator B shall be switched on and adjusted to -31 dBm at the receiver;
- h) the frequency of the unwanted signal shall be varied in steps of 5 kHz over the limited frequency range (from LFR_{LO} to LFR_{HI});
- i) the frequency of any spurious response detected (by an increase in either PER or BER) during the search shall be recorded for use in the next measurements;
- j) in the case where operation using a continuous packet stream is not possible, a similar method may be used.

If the manufacturer's specified receiver frequencies do not include 161,975 MHz, one of the manufacturer's specified receiver frequencies may be used as an alternative.

7.2.5.7 Method of measurement (at identified frequencies)

The measurement procedure shall be as follows with reference to Figure 17:

- a) two generators A and B shall be connected to the receiver via a combining network;
- b) the wanted signal, provided by generator A, shall be at 161,975 MHz and shall be modulated to generate test signal number 3;
- c) the unwanted signal, provided by generator B, shall be frequency modulated with a 400 Hz sine wave giving a deviation of ± 3 kHz. Generator B shall be at the frequency of that spurious response being considered;
- d) initially, signal generator B (unwanted) shall be switched off (maintaining the output impedance);
- e) the signal level from generator A (wanted) shall be adjusted to -101 dBm for type 3 or -91 dBm for type 2 at the receiver;

- f) signal generator B shall be switched on, and the level of the unwanted signal set to -31 dBm;
- g) for each frequency noted during the tests over the limited frequency range and the specific frequencies of interest (SFI_1 and SFI_2), transmit 200 packets to the EUT and note the PER.

If the manufacturer's specified receiver frequencies do not include 161,975 MHz, one of the manufacturer's specified receiver frequencies may be used as an alternative.

7.2.5.8 Required results

At any frequency separated from the specified frequency of the receiver by 50 kHz or more, the PER shall not exceed 20 %.

7.2.6 Inter-modulation response rejection

7.2.6.1 Purpose

The inter-modulation response rejection is the capability of the receiver to receive a wanted modulated signal, without exceeding a given degradation due to the presence of two close-spaced unwanted signals with a specific frequency relationship to the wanted signal frequency.

7.2.6.2 Method of test

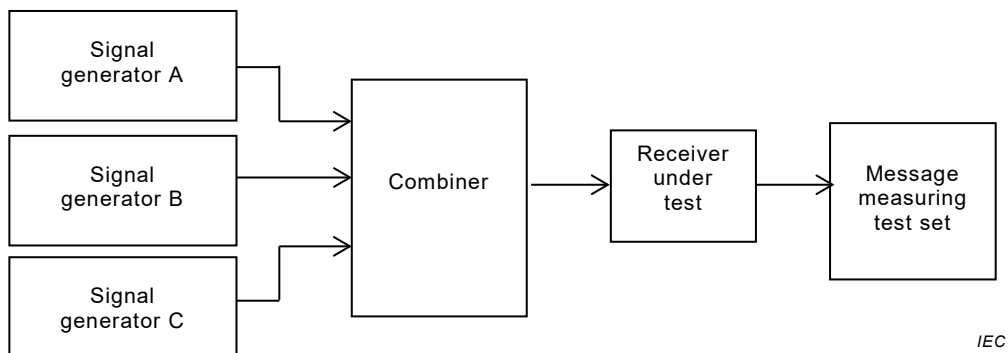

Figure 18 – Measurement arrangement for inter-modulation

The measurement procedure shall be as follows with reference to Figure 18:

- a) three signal generators shall be connected to the receiver via a combining network;
- b) the wanted signal, provided by signal generator A, shall be at the specified frequency of the receiver and shall be modulated to generate test signal number 3;
- c) the unwanted signal from generator B shall be unmodulated;
- d) the unwanted signal from generator C shall be frequency modulated with a 400 Hz sine wave at a deviation of ± 3 kHz;
- e) the signal level from generator A (wanted) shall be set for -101 dBm for type 3 or -91 dBm for type 2 at the receiver input;
- f) the signal level from generators B and C shall be set for -36 dBm at the receiver input;
- g) the frequencies of generators A, B, C shall be set as per test number 1 of Table 22;
- h) the message measuring test set shall be monitored and the PER observed over 200 transmissions;
- i) repeat the measurement with frequencies set as per test number 2 of Table 22.

Table 22 – Frequencies for inter-modulation test

Test number	Generator A Wanted AIS Signal	Generator B Unmodulated (±500 kHz)	Generator C Modulated (±1 000 kHz)
1 (RATDMA receiver)	162,025 MHz	161,525 MHz	161,025 MHz
1 (Non-RATDMA receiver)	Highest operating frequency on which the EUT can operate	Highest operating frequency on which the EUT can operate – 500 kHz	Highest operating frequency on which the EUT can operate – 1 000 kHz
2 (both RATDMA and non- RATDMA receiver)	Lowest operating frequency on which the EUT can operate	Lowest operating frequency on which the EUT can operate + 500 kHz	Lowest operating frequency on which the EUT can operate + 1 000 kHz

7.2.6.3 Required results

The PER shall not exceed 20 %.

7.2.7 Blocking or desensitization

7.2.7.1 Purpose

Blocking is a measure of the capability of the receiver to receive a wanted modulated signal without exceeding a given degradation due to the presence of an unwanted input signal at any frequency other than those of the spurious responses or the adjacent channels.

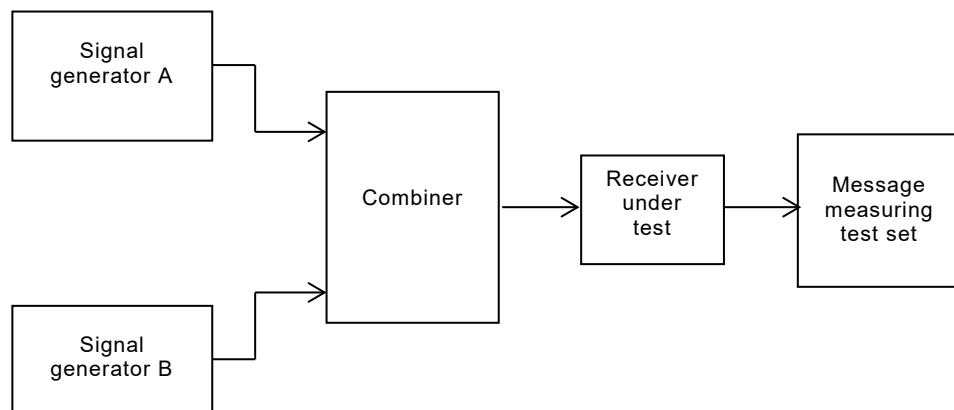

IEC

Figure 19 – Measurement arrangement for blocking or desensitisation

7.2.7.2 Method of measurement

The measurement procedure shall be as follows:

- two generators A and B, shall be connected to the receiver via a combining network as shown in Figure 19;
- the wanted signal, provided by signal generator A, shall be at the lowest operating frequency on which the EUT can transmit (or receive for a non-RATDMA receiver) according to the manufacturers specification and be modulated with test signal number 3;
- the unwanted signal from generator B shall be unmodulated and shall be at a frequency 0,5 MHz to 10 MHz away from the lowest declared frequency of the receiver. Measurements shall be carried out at frequencies of the unwanted signal at ± 500 kHz,

- ± 1 MHz, ± 2 MHz, ± 5 MHz and ± 10 MHz avoiding those frequencies where spurious responses could occur;
- d) initially, signal generator B (unwanted signal) shall be switched off (maintaining the output impedance). The level of the wanted signal from generator A shall be adjusted to -101 dBm for type 3 and -91 dBm for type 2 at the receiver input;
 - e) the RF signal level for signal generator B (unwanted signal) shall be adjusted to -23 dBm when the frequency setting is less than ± 5 MHz with respect to the frequency setting of RF signal generator A. For frequency settings of signal generator B that are equal to or greater than ± 5 MHz with respect to the frequency setting of generator A, the RF signal level shall be adjusted to -15 dBm. This applies to type 3 receivers only;
 - f) the RF signal level for signal generator B (unwanted signal) shall be adjusted to -33 dBm when the frequency setting is less than ± 5 MHz with respect to the frequency setting of RF signal generator A. For frequency settings of signal generator B that are equal to or greater than ± 5 MHz with respect to the frequency setting of generator A, the RF signal level shall be adjusted to -25 dBm. This applies to type 2 receivers only;
 - g) 200 packets shall be transmitted and the PER recorded;
 - h) repeat the test steps a) to f) with signal generator A tuned to the highest operating frequency on which the EUT can receive as declared by the manufacturer.

7.2.7.3 Required results

The PER shall not exceed 20 %.

7.3 Conducted spurious emissions at the antenna

7.3.1 Spurious emissions from the receiver

7.3.1.1 Purpose

Conducted spurious emissions to the antenna are any RF emissions generated in the receiver and conveyed to the antenna terminal.

7.3.1.2 Method of measurement

Conducted spurious emissions shall be measured as the power level of any frequency component to the antenna terminals of the receiver. The receiver antenna terminals are connected to a spectrum analyser or selective voltmeter having an input impedance of 50Ω and the receiver is switched on.

The measurement shall extend over the frequency range 9 kHz to 4 GHz.

7.3.1.3 Required results

The power of any spurious emission in the specified range at the antenna terminal shall not exceed -57 dBm in the frequency range 9 kHz to 1 GHz and -47 dBm in the frequency range 1 GHz to 4 GHz.

7.3.2 Spurious emissions from the transmitter

7.3.2.1 Purpose

Spurious emissions are emissions at frequencies other than those of the carrier and sidebands associated with normal modulation.

7.3.2.2 Method of measurement

Conducted spurious emissions shall be measured with the unmodulated transmitter connected to the artificial antenna. The measurement shall be made over a frequency range from 9 kHz to 4 GHz, excluding the frequencies within $\pm 62,5$ kHz of the transmitting frequency.

7.3.2.3 Required results

The power of any spurious emission outside $\pm 62,5$ kHz of the transmitting frequency shall not exceed -36 dBm in the frequency range 9 kHz to 1 GHz and -30 dBm in the frequency range 1 GHz to 4 GHz.

8 Functional tests

8.1 Configuration method

8.1.1 General

For all of the functional tests the setup for the method of measurement shall be as defined by the manufacturer:

- using standard configuration sentences via direct connection to an interface, or
- using standard configuration sentences via VDL, or
- using the manufacturer's proprietary method.

8.1.2 Configuration for Message 21

8.1.2.1 Purpose

The purpose of this test is to ensure that Message 21 parameters can be entered into the EUT and are retained after the power off/on cycle.

8.1.2.2 Method of measurement

Set up the standard test environment.

- a) With the MMSI of EUT set to 000000000, configure a valid transmission schedule for Message 21, using the CBR sentence with MMSI in the first field set to 000000000 to match the MMSI of EUT.
- b) Configure the EUT with the following parameters for transmission of Message 21:
 - MMSI number: 991234567;
 - type of AtoN: "20" – cardinal mark north;
 - name of AtoN: "TEST FLOATING AIS ATON STATION";
 - position accuracy: to accuracy of EPFS;
 - assigned position (longitude and latitude): "within off-position threshold of current EPFS position";
 - dimension/reference for position: "A=B=C=D=5";
 - type of EPFS: Enter EUT's EPFS type (for example "1" for GPS);
 - off-position threshold: 200 m;
 - set power level;
 - channel 1 set to channel 2087; if receiver supported, set channel 1 receiver to same;
 - channel 2 set to channel 2088; if receiver supported, set channel 2 receiver to same;
 - Virtual AtoN flag set to 0 = default = Real AtoN at indicated position;
 - set AtoN status default (00000000);
 - off-position behaviour set to "maintain current transmission schedule";
 - set UTC lost behaviour as per manufacturer's declaration;
 - read configuration from EUT.
- c) Remove power from the EUT for 5 min. Switch on the EUT. Read configuration from EUT.

NOTE Standard configuration sentences via configuration port: the Message 21 content is configured using the AID, ACF and ACG sentence combination.

Standard configuration sentences via VDL: the Message 21 content is configured via VDL using Message 25 or Message 6 with the appropriate application identifier/function identifier and binary data.

8.1.2.3 Required results

Verify that configuration is:

- a) not accepted by EUT and the EUT does not start transmission of Message 21;
- b) accepted by EUT and that the parameters have been correctly set;
- c) retained after power cycle.

8.1.3 Schedule mode A FATDMA Message 21 (single report, alternating channel operation)

8.1.3.1 Purpose

Test that the AIS AtoN Station operates in accordance with the configured reporting schedule (see 5.2.5.2).

8.1.3.2 Method of measurement

Set up the standard test environment and use the configuration as defined in 8.1.2.

- a) Configure reporting of Message 21 to have the following parameters:
 - start on channel 2;
 - start slot: 512;
 - reporting interval: 3 min;
 - frame for the first transmission in every UTC hour: UTC minute: 1;
 - start the EUT 2 min ahead of a schedule transmission.
- b) Run the test over the hour and day boundary.

If synthetic and virtual AIS AtoN Message 21 reports are implemented (see 5.2.2.1.2):

- c) Change the configuration of the EUT to be a synthetic AIS AtoN. Repeat the test.
- d) Change the configuration of the EUT to be a virtual AIS AtoN. Repeat the test.
- e) Repeat test a). Apply Message 20 on channel A and B reserving the slots assigned for FATDMA transmission.

NOTE Standard configuration sentences via configuration port: the schedule for Mode A FATDMA transmission is configured using the CBR sentence.

Standard configuration sentences via VDL: the schedule for Mode A FATDMA transmissions via VDL is configured using Message 25 or Message 6 with the appropriate application identifier/function identifier, and binary data.

8.1.3.3 Required results

Verify that the:

- a) EUT transmits Test Message 21 in the configured slots on both channels. EUT starts transmission in the correct UTC frames and alternates channels at the reporting interval within one reporting interval (3 min in this case), and should not wait until UTC minute 1. (The channel 1 transmissions shall occur in minutes 4, 10, 16, 22, 28, 34, 40, 46, 52 or 58 with an increment of 6 min; the channel 2 transmissions shall occur in minutes 1, 7, 13, etc. with an increment of 6 min);
- b) reporting behaviour is consistent through the hour and day boundaries and transmitted data is correct;

If synthetic and virtual AIS AtoN Message 21 reports are implemented:

- c) Message 21 repeat indicator is 1;
- d) Message 21 virtual flag is set;
- e) EUT continues transmission of Message 21 using the reserved slots.

8.1.4 Schedule mode B FATDMA Message 21 (dual report, dual channel operation)

8.1.4.1 Purpose

Test that the AIS AtoN station operates in accordance with configured reporting schedule 5.2.5.3.1 and transmits correct data.

8.1.4.2 Method of measurement

Setup the standard test environment and use the configuration as defined in 8.1.2.

- a) Configure reporting of Message 21 to have the following parameters:
 - start channel 1: start slot 512;
 - channel 2: start slot: 612;
 - reporting interval: 3 min,
 - frame for the first transmission in every UTC hour: UTC minute 2;
 - start the EUT 2 min ahead of a schedule transmission.
- b) Run the test over the hour and day boundary.

NOTE Standard configuration sentences via configuration port: the schedule for Mode B FATDMA transmission is configured using the CBR sentence.

Standard configuration sentences via VDL: the schedule for Mode B FATDMA transmissions via VDL is configured using Message 25 or Message 6 with the appropriate application identifier/function identifier, and binary data.

8.1.4.3 Required results

Verify that the:

- a) EUT transmits Test Message 21 in the configured slots on both channels. EUT starts transmission in the correct UTC frame and continues with the correct increment within one reporting interval and should not wait until UTC minute 2;
- b) reporting behaviour is consistent through the hour and day boundaries and transmitted data is correct.

8.1.5 Schedule mode C FATDMA Message 21 (single report, single channel operation)

8.1.5.1 Purpose

The purpose is to test that the AIS AtoN station operates in accordance with the configured reporting.

8.1.5.2 Method of measurement

Setup the standard test environment and use the configuration as defined in 8.1.2.

- a) Configure reporting of Message 21 to have the following parameters:
 - transmit channel: A or B;
 - start slot: 512;
 - reporting interval: 3 min;
 - frame for the first transmission in every UTC hour: UTC minute: 1;

- start the EUT 2 min ahead of a schedule transmission.

b) Run the test over the hour and day boundary.

NOTE Standard configuration sentences via configuration port: the schedule for Mode C FATDMA transmission is configured using the CBR sentence.

Standard configuration sentences via VDL: the schedule for Mode C FATDMA transmissions via VDL is configured using Message 25 or Message 6 with the appropriate application identifier/function identifier, and binary data.

8.1.5.3 Required results

Verify that the:

- a) EUT transmits test Message 21 in the configured slots on the designated transmit channel, EUT starts transmission in the correct UTC frame on the designated transmit channel at the reporting interval within one reporting interval and should not wait until UTC minute 1;
- b) reporting behaviour is consistent through the hour and day boundaries and transmitted data is correct.

8.1.6 Schedule mode A RATDMA Message 21 (Type 3) (single report, alternating channel operation)

8.1.6.1 Purpose

The purpose of this test is to ensure that the EUT can be configured to operate in accordance with 5.2.4.2, ensuring the selection interval is random within the 1 min interval and that the slot reuse algorithm is properly implemented.

8.1.6.2 Method of measurement

Set up the standard test environment and use the configuration as defined in 8.1.2 with a VDL loading of 10 %.

- a) Configure reporting of Message 21 with the following parameters:
 - FATDMA setup or RATDMA setup: RATDMA;
 - UTC minute for CH1: 1;
 - UTC minute for CH2: 4;
 - time interval CH1: 360 (6 min);
 - time interval CH2: 360 (6 min).
- b) Apply a VDL load that necessitates intentional slot reuse and repeat the test;
- c) Apply invalid RATDMA reporting intervals for transmission of Message 21. The valid intervals are defined in 5.2.3;
- d) Configure the AtoN with the highest possible reporting rate. Apply Message 20 reserving 50 % of the slots including the RATDMA selection interval. Run the test for 12 hours;
- e) Apply an SPO sentence to activate a VSI and FSR sentence. Apply some targets to the VDL.

NOTE Standard configuration sentences via configuration port: the schedule for Mode A RATDMA transmission is configured using the CBR sentence.

Standard configuration sentences via VDL: the schedule for Mode A RATDMA transmissions via VDL is configured using Message 25 or Message 6 with the appropriate application identifier/function identifier, and binary data.

8.1.6.3 Required results

Verify that the:

- a) EUT transmits test Message 21:

- using RATDMA so that the slot selection is random within the correct frames, and alternates the transmission channel between successive reports;
- with the correct reporting intervals;
- with the correct data.

EUT selects its slots randomly;

- b) EUT applies the slot reuse algorithm as defined in Recommendation ITU-R M.1371;
- c) invalid reporting intervals are not accepted;
- d) slots reserved by Message 20 are not used for the transmission of Message 21 for at least 12 h. Using means declared by the manufacturer, verify that the receiver remains on for 7 min at least once every 12 h;
- e) Verify that the information provided in the VSI and FSR sentences are in accordance with the manufacturer's documentation.

8.1.7 Schedule mode B RATDMA Message 21 (Type 3) (dual report, dual channel operation)

8.1.7.1 Purpose

The purpose of this test is to ensure that the AIS AtoN station can be configured to operate in accordance with 5.2.4.2.

8.1.7.2 Method of measurement

Setup the standard test environment and use the configuration as defined in 8.1.1 with a VDL loading of 10 %.

Configure reporting of Message 21 with the following parameters:

- FATDMA setup or RATDMA setup: RATDMA;
- UTC minute for CH1: 1;
- UTC minute for CH2: 4;
- time interval CH1: 180 (3 min);
- time interval CH2: 180 (3 min).

NOTE Standard configuration sentences via configuration port: the schedule for Mode B RATDMA transmission is configured using the CBR sentence.

Standard configuration sentences via VDL: the schedule for Mode B RATDMA transmissions via VDL is configured using Message 25 or Message 6 with the appropriate application identifier/function identifier, and binary data.

8.1.7.3 Required results

Verify that the EUT transmits test Message 21:

- using RATDMA so that the slot selection is random within the 1 min interval, with dual reports on both channels;
- sending in correct intervals;
- with correct transmitted data.

8.1.8 Schedule mode C RATDMA Message 21 (type 3) (single channel operation)

8.1.8.1 Purpose

The purpose of this test is to ensure that the AIS AtoN station can be configured to operate in accordance with 5.2.4.2.

8.1.8.2 Method of measurement

Setup the standard test environment and use the configuration as defined in 8.1.1 with a VDL loading of 10 %.

Configure reporting of Message 21 with the following parameters:

- FATDMA setup or RATDMA setup: RATDMA;
- UTC minute for CH1: 1;
- time interval CH1: 180 (3 min).

NOTE Standard configuration sentences via configuration port: the schedule for Mode C RATDMA transmission is configured using the CBR sentence.

Standard configuration sentences via VDL: the schedule for Mode C RATDMA transmissions via VDL is configured using Message 25 or Message 6 with the appropriate application identifier/function identifier, and binary data.

8.1.8.3 Required results

Verify that the EUT transmits test Message 21:

- using RATDMA so that the slot selection is random within the 1 min interval with single reports on a single channel;
- sending in correct intervals;
- with correct transmitted data.

8.1.9 Scheduled transmission of Message 6

8.1.9.1 Purpose

The purpose of this test is to verify the Message 6 operation of the EUT using the implemented access methods.

8.1.9.2 Method of measurement

Setup the standard test environment and use the configuration as defined in 8.1.1 and transmission schedule for Message 21 as defined in 8.1.2 with an “intended recipient” MMSI. The recipient shall acknowledge the message.

- a) Configure the EUT as defined by manufacturer’s documentation for transmission of a scheduled addressed binary data Message 6 with test binary data consisting of the bit pattern hex “7E 3B 3C 3E 7E” or internally generated data forming a message by setting the parameters for the following operation modes, where implemented:
 - FATDMA (see 8.1.2 for mode A setup; 8.1.3 for mode B setup; 8.1.4 for mode C setup);
 - RATDMA (see 8.1.5 for mode A setup; 8.1.6 for mode B setup; 8.1.7 for mode C setup);
 - CSTDMA: time (hour, minute), channel(s), reporting interval.
- b) Repeat the test for a type 3 AtoN without an acknowledgement from the intended recipient.
- c) If possible to use externally generated data, repeat the test exceeding the maximum length of Message 6.
- d) Repeat the test for the maximum length of Message 6 by repeating the bit pattern hex “7E 3B 3C 3E 7E” sequence in the binary data field.

8.1.9.3 Required results

Verify that the EUT continues transmitting Message 21 in all cases and that:

- a) the message sent by the EUT conforms to message content, access method, channel, slot number and reporting interval;
- b) the EUT behaves as configured;
- c) the message is not sent;
- d) the message is sent with the correct content.

NOTE CSTDMA access of Message 6 complies with IEC 62287-1 with regard of VDL access and message length.

8.1.10 Scheduled transmission of Message 8

8.1.10.1 Purpose

The purpose of this test is to verify that Message 8 can be entered into the EUT.

8.1.10.2 Method of measurement

Set up the standard test environment and use the configuration as defined in 8.1.1 and transmission schedule for Message 21 as defined in 8.1.2.

- a) Configure the EUT as defined by the manufacturer's documentation for transmission of a scheduled binary data Message 8 with test binary data consisting of the bit pattern hex "7E 3B 3C 3E 7E" forming a message by setting the parameters for the following operation modes, where implemented:
 - FATDMA (see 8.1.2 for mode A setup; 8.1.3 for mode B setup; 8.1.4 for mode C setup);
 - RATDMA (see 8.1.5 for mode A setup; 8.1.6 for mode B setup; 8.1.7 for mode C setup);
 - CSTDMA: time (hour, minute), channel(s), reporting interval.
- b) If possible, use externally generated data, repeat the test exceeding the maximum length of Message 8.
- c) Repeat the test for the maximum length of Message 8 by repeating the bit pattern hex "7E 3B 3C 3E 7E" sequence in the binary data field.

8.1.10.3 Required results

Verify that:

- a) the message sent by the EUT conforms to message content, access method, channel, slot number and reporting interval;
- b) message is not sent;
- c) message is sent with the correct content.

In all cases, the EUT should continue transmitting Message 21.

NOTE CSTDMA access of Message 6 complies with IEC 62287-1 with regard to VDL access and message length.

8.1.11 Scheduled transmission of Message 12

Repeat tests 8.1.8 and 8.1.9 for Message 12.

8.1.12 Scheduled transmission of Message 14

Repeat tests 8.1.10 for Message 14.

8.1.13 Unscheduled transmission

8.1.13.1 Purpose

Unscheduled transmissions are those transmissions that are not planned, and the competent authority wishes the AtoN station to broadcast them autonomously, such as an unexpected alarm condition. The VDL access method for these message types is RATDMA. This test will verify the AtoN operation when such a message is input.

This test is only applicable for type 3 AtoN stations.

8.1.13.2 Method of measurement

Set up the standard test environment and use the configuration as defined in 8.1.2 and transmission schedule for Message 21 as defined in 8.1.3 with an “intended recipient” MMSI.

- a) Apply a BBM sentence with Message 8.
- b) Apply a BBM sentence with Message 14.
- c) Configure the acknowledgement behaviour to 1 (acknowledgement expected). Apply an ABM sentence with Message 6. Do not apply an acknowledgement on the VDL.
- d) Apply an ABM sentence with Message 6. Apply an acknowledgement Message 7 on the VDL within 4 s after the transmission of Message 6.
- e) Configure the acknowledgement behaviour to 0 (no acknowledgement expected). Apply an ABM sentence with Message 6. Do not apply an acknowledgement on the VDL.
- f) Apply an ABM sentence with Message 12. Do not apply an acknowledgement on the VDL.

NOTE Standard IEC 61162-1 sentences: an unscheduled message using standard format would be ABM, ABK or BBM.

8.1.13.3 Required results

Check that the EUT continues to transmit Message 21 in all cases.

- a) Check that Message 8 is transmitted within 4 s using RATDMA with correct content. Check that there is an ABK output with correct content and status 3.
- b) Check that Message 14 is transmitted within 4 s using RATDMA with correct content. Check that there is an ABK output with correct content and status 3.
- c) Check that Message 6 is transmitted within 4 s using RATDMA with correct content. Check that Message 6 is repeated 3 times, 4 to 8 s after the previous transmission. Check that there is an ABK output with correct content and status 1.
- d) Check that Message 6 is transmitted within 4 s. Check that Message 6 is not repeated. Check that there is an ABK output with correct content and status 0.
- e) Check that Message 6 is transmitted within 4 s. Check that Message 6 is not repeated. Check that there is an ABK output with correct content and status 3.
- f) Check that Message 12 is transmitted within 4 s. Check that Message 12 is not repeated. Check that there is an ABK output with correct content and status 3.

8.2 Synchronisation accuracy

8.2.1 Implemented synchronisation modes and synchronisation error

8.2.1.1 Purpose

The purpose is to verify the implemented synchronisation modes and measure the synchronisation error of the EUT.

8.2.1.2 Method of measurement

Setup the standard test environment and operate EUT in normal mode. Set the EUT reporting interval to 1 min for Message 21 and all other implemented messages.

Operate the EUT in all implemented synchronisation modes:

- EUT using UTC direct synchronisation;
- EUT using UTC indirect synchronisation;
- EUT using semaphore synchronisation.

Record VDL messages and measure the time between the nominal beginning of the slot interval and the initiation of the 'transmitter on' function by evaluating the start flag and calculating back to T_0 .

8.2.1.3 Required results

The synchronisation error with its additive jitter shall not exceed:

- $\pm 104 \mu\text{s}$ using UTC direct synchronisation;
- $\pm 312 \mu\text{s}$ using UTC indirect synchronisation;
- $\pm 312 \mu\text{s}$ referenced to the semaphore's synchronisation.

8.2.2 Synchronisation test without UTC (types 2 and 3)

8.2.2.1 Purpose

The purpose of this test is to verify that the EUT can synchronise without UTC.

8.2.2.2 Method of measurement

Setup the standard test environment and use the configuration as defined in 8.1.2. Choose test conditions in a way that the EUT receives messages from a synchronisation source with the following synchronisation states:

- a) base station direct acting as a semaphore synchronisation and no stations with direct or UTC indirect synchronisation; disable internal synchronisation source;
- b) mobile direct acting as a semaphore synchronisation and no stations with direct or UTC indirect synchronisation; disable internal synchronisation source;
- c) mobile station indicating UTC indirect synchronisation and receiving no stations with direct synchronisation or base stations with UTC indirect synchronisation; disable internal synchronisation source;
- d) enable internal synchronisation source.

Record transmitted messages.

8.2.2.3 Required results

Verify that the EUT transmits according to its implemented synchronisation modes in each case.

- a) Verify that the EUT synchronises to the base station acting as semaphore.
- b) Verify that the EUT synchronises to the mobile station acting as semaphore.
- c) Verify that the EUT does not synchronise to any station.
- d) Verify that the EUT returns to UTC direct synchronisation.

8.3 EPFS

8.3.1 Position source

8.3.1.1 Purpose

The purpose of this test is to verify that the position source correctly populates the fields in Message 21.

8.3.1.2 Method of measurement

Setup the standard test environment and use the configuration as defined in 8.1.1.

- a) Using the transmission schedule for Message 21 as defined in 8.1.2, record the EUT transmissions.
- b) Repeat the test with a surveyed position.

8.3.1.3 Required results

Verify that:

- a) the position and time stamp fields are valid;
- b) the EUT has the correct parameter settings for “type of electronic position fixing device” and “RAIM-flag”.

8.3.2 Invalid position

8.3.2.1 Purpose

The purpose of this test is to verify that the EUT responds correctly when the EPFS outputs an invalid position.

8.3.2.2 Method of measurement

Setup the standard test environment and use the configuration as defined in 8.1.2 and transmission schedule for Message 21 as defined in 8.1.2. Prevent the EPFS receiver from generating position fixes.

8.3.2.3 Required results

If the EUT is configured to continue transmission, verify that the EUT transmits Message 21 with the parameters latitude and longitude set to “not available” and that the time stamp is set to “63”.

8.3.3 Off-position monitor

8.3.3.1 Purpose

The purpose of this test is to verify that the EUT responds correctly when it is off position.

8.3.3.2 Method of measurement

Setup the standard test environment and use the configuration as defined in 8.1.1 and transmission schedule for Message 21 as defined in 8.1.2.

- a) Set the EUT EPFS antenna at its assigned position and with off-position behaviour set to maintain current broadcast schedule.
- b) After verification of the off-position indicator in Message 21, the EUT EPFS antenna shall be moved to off-position.
- c) Move the EUT EPFS antenna to be on position.

- d) If implemented, configure the EUT with off-position behaviour set to a new reporting interval and the EUT EPFS antenna shall be moved to off-position.
- e) After verification of the off-position indicator in Message 21, the EUT EPFS antenna shall be moved to on-position.

8.3.3.3 Required results

Verify that:

- a) Message 21 has the off-position indicator field set to “0”;
- b) Message 21 has the off-position indicator field set to “1” within a time period stated by the manufacturer and that the original reporting schedule has not changed;
- c) Message 21 has the off-position indicator field set to “0” within a time period stated by the manufacturer;
- d) Message 21 has the off-position indicator field set to “1” within a time period stated by the manufacturer and that the original reporting schedule has changed to the new reporting interval;
- e) Message 21 has the off-position indicator field set to “0” within a time period stated by the manufacturer and the reporting interval returns to the original reporting schedule.

8.4 Receive addressed message (types 2 and 3)

8.4.1 Purpose

The purpose of this test is to verify that the EUT correctly receives and, if so configured, processes an addressed message.

8.4.2 Method of measurement

Setup the standard test environment and use the configuration as defined in 8.1.1 and transmission schedule for Message 21 as defined in 8.1.2. Record received messages and frame structure.

- a) Apply an addressed binary message (Message 6; EUT as destination) to the VDL.
- b) Apply an addressed binary message (Message 6; other station as destination) to the VDL.

8.4.3 Required results

Verify that:

- a) EUT receives and processes the message in accordance with the manufacturer's specification;
- b) EUT does not process the received message.

8.5 Interrogation response (Type 3)

8.5.1 Purpose

The purpose of this test is to verify that the EUT correctly receives and processes an interrogation correctly.

8.5.2 Method of measurement

Setup the standard test environment and use the configuration as defined in 8.1.1 and transmission schedule for Message 21 as defined in 8.1.2. Record received messages and frame structure. Configure at least one virtual AtoN.

- a) Apply an interrogation message for Message 21 of the real AtoN to the VDL;
- b) Apply an interrogation message for Message 21 of the virtual AtoN to the VDL;

- c) Apply an interrogation message for Message 21 of an MMSI not used by the EUT to the VDL;
- d) Apply an interrogation message addressed to the real AtoN for a message other than Message 21 to the VDL.

8.5.3 Required results

Verify that the:

- a) EUT receives and processes the message and responds with a Message 21 that contains the MMSI and position of the real AtoN;
- b) EUT receives and processes the message and responds with a Message 21 that contains the MMSI and position of the real AtoN;
- c) EUT receives and processes the message and does not respond;
- d) EUT receives and processes the message and does not respond.

8.6 Repeat AIS-SART messages

8.6.1 Purpose

The purpose of this test is to verify that the active AIS-SART messages are repeated if this option is implemented.

8.6.2 Method of measurement

Setup the standard test environment and use the configuration as defined in 8.1.1 and transmission schedule for Message 21 as defined in 8.1.2. Record received messages and frame structure. Configure at least one virtual AtoN.

- a) Apply an active AIS-SART message burst including Message 1 and 14 to the VDL;
- b) Apply an AIS-SART test message to the VDL.

8.6.3 Required results

Verify that the:

- a) EUT receives and processes the message and repeats Message 14 and only one of the Message 1 active AIS-SART messages, and increments the repeat indicator;
- b) EUT does not repeat the AIS-SART test messages.

8.7 Additional functionality as implemented by the manufacturer

8.7.1 Test for configuration of the receiver turn-on times (types 2 and 3)

8.7.1.1 Purpose

The purpose of this test is to ensure that the operational time period for the receivers can be configured using the configuration port of the EUT or the appropriate VDL message.

8.7.1.2 Method of measurement

Set up the standard test environment and operate the EUT in normal mode.

Configure the receiver turn-on times of the EUT with the following parameters:

- MMSI of the AtoN station,
- operational mode,
- start time,
- duration of period,

- time interval between periods.

Using the implemented methods (one or both), enter the appropriate data with the parameter “operational mode”.

- a) Configure the receiver to be on all the time (operational mode = 1).
- b) Enter the appropriate data with a definition of a turn on interval.
- c) Query the COP configuration of the receiver turn-on times via the configuration port using the query sentence or other means provided by the manufacturer.
- d) Query the COP configuration of the receiver turn-on times via the VDL and define a FATDMA slot for the VDL replay.
- e) Repeat step b) with an invalid time interval between periods parameter.
- f) Repeat step c) to validate that the schedule has not changed.

NOTE Standard configuration sentences via configuration port: the receiver turn-on times are configured using the COP sentence.

Standard configuration sentences via VDL: the receiver turn-on times are configured via the VDL using Message 25 or Message 6 with the appropriate application identifier/function identifier, and binary data.

8.7.1.3 Required results

Verify that:

- a) the EUT receiver is turned on all the time;
- b) the EUT receiver is turned on during the defined time period and interval;
- c) the EUT returns on a query with the appropriate message content via PI using the COP sentence;
- d) the EUT returns on a query via the VDL with the appropriate VDL message on the assigned slot and channel using the appropriate application identifier and binary data;
- e) the EUT returns a NAK using reason code 11 with the NAK descriptive text “invalid interval”, and the COP shall be ignored;
- f) the EUT returns on a query with the appropriate message content from the previous configuration via PI using the COP sentence.

8.7.2 Test for configuration of payload transmission

8.7.2.1 Purpose

The purpose of this test is to ensure that the EUT can be commanded to transmit a payload using the slots reserved by a preceding CBR with message ID = 0 and message ID index = 0. The payload can be entered into the EUT using the configuration port of the EUT or the appropriate VDL configuration message.

8.7.2.2 Method of measurement

Set up the standard test environment and operate the EUT in normal mode.

Configure an FATDMA transmission schedule for message ID = 0, message ID index = 0, slot interval = 750 slots on channel A and B, slot distance between channel A and B = 375 slot.

- a) Apply an MEB with Message ID = 6, Message ID index = 0, broadcast behaviour = 1 and a valid destination MMSI.
- b) Apply an MEB with Message ID = 12, Message ID index = 0, broadcast behaviour = 1 and a valid destination MMSI.
- c) Apply an MEB with Message ID = 8, Message ID index = 0, broadcast behaviour = 1.
- d) Apply an MEB with Message ID = 14, Message ID index = 0, broadcast behaviour = 1.

8.7.2.3 Required results

Verify that:

- a) a single Message 6 is transmitted in the next available slot, defined by the CBR sentence, with correct content according to the MEB input;
- b) a single Message 12 is transmitted in the next available slot, defined by the CBR sentence, with correct content according to the MEB input;
- c) a single Message 8 is transmitted in the next available slot, defined by the CBR sentence, with correct content according to the MEB input;
- d) a single Message 14 is transmitted in the next available slot, defined by the CBR sentence, with correct content according to the MEB input.

8.7.3 Test for forced broadcast

8.7.3.1 Purpose

The purpose of this test is to ensure that the EUT can be forced to broadcast a specified VDL message via the PI or the VDL.

8.7.3.2 Method of measurement

Setup the standard test environment and operate the EUT in normal mode. Enter the forced broadcast data to the EUT with the following parameters:

- message type;
- message identifier;
- VDL channel for message transmission;
- time and slot message transmission;
- number of consecutive slots for message transmission.

Using the implemented methods (one or both) enter the appropriate forced broadcast data to the EUT.

NOTE Standard configuration sentences via configuration port: the forced broadcast data is configured using the AFB sentence.

Standard configuration sentences via VDL: the forced broadcast data is configured via the VDL using Message 25 or Message 6 with the appropriate application identifier/function identifier, and binary data.

8.7.3.3 Required results

Verify that the EUT transmits the requested VDL message at the defined time and slot.

8.7.4 Test for version information

8.7.4.1 Purpose

The purpose of this test is to ensure that the EUT can provide version information.

8.7.4.2 Method of measurement

Setup the standard test environment and operate the EUT in normal mode. Enter the query for version information to the EUT using the manufacturer's implemented methods.

NOTE Standard configuration sentences via configuration port: the version information is queried using the QVER sentence and the response is provided using VER.

Standard configuration sentences via VDL: the version information is queried via VDL using Message 25 or Message 6 with the appropriate application identifier/function identifier, and binary data

8.7.4.3 Required results

Verify that the EUT provides with the requested version information.

8.7.5 Test for DCR – AtoN function ID capability

8.7.5.1 Purpose

The purpose of this test is to ensure that the EUT can provide a list of supported functionality.

8.7.5.2 Method of measurement

Setup the standard test environment and use the configuration as defined in 8.1.1 and transmission schedule for Message 21 as defined in 8.1.2. Enter the query for the function supported.

NOTE Standard configuration sentences via configuration port: the list of supported functions is queried using the "Q,DCR" sentence and the response is provided using DCR.

Standard configuration sentences via VDL: the list of supported functions is queried via the VDL using Message 25 or Message 6 with the appropriate application identifier/function identifier, and binary data.

8.7.5.3 Required results

Verify that the EUT provides the list of functions that are supported by the AtoN station.

8.7.6 Test for assigning an encryption key for VDL configuration

8.7.6.1 Purpose

The purpose of this test is to ensure that the encryption key for VDL configuration can be entered into the EUT using the configuration port or the appropriate VDL message.

The initial encryption key, when shipped from the manufacturer, will be all zeros.

8.7.6.2 Method of measurement

Setup standard test environment and operate the EUT in normal mode.

- a) Configure the EUT with the initial factory default encryption key of all zeros.
Send a configuration message encrypted with the initial factory default AES encryption key;
- b) Configure the EUT with a different AES encryption key.
Send a configuration message encrypted with the new AES encryption key;
- c) Send a configuration message encrypted with a different AES encryption key;

NOTE Via configuration port: enter the encryption key via the configuration port using the CEK sentence or any other means provided by the manufacturer. The sentence used on the configuration port allows for an encryption key of up to 256 bits to be entered using multiple sentences.

Via VDL: enter the encryption key via the VDL using Message 25 or Message 6 with the appropriate application identifier and binary data. The VDL message allows the entire key of up to 256 bits to be modified.

8.7.6.3 Required results

Verify that:

- a) the EUT does not accept the new configuration;
- b) the EUT accepts the new configuration;
- c) the EUT does not accept the new configuration.

8.7.7 Test for VDL configuration using chaining (Type 3)

8.7.7.1 Purpose and setup

The purpose of these tests is to verify that, if chaining is implemented, the AtoN station supports receiving information from a base station via intermediate AtoN stations and then transmits the response back through the intermediate AtoN stations to the base station.

Perform the following tests with Message 25 if no other message is specified. All involved AtoN stations are of the EUT type. The manufacturer has to supply a sufficient number of units to perform the test.

In the following test the base station is simulated by the test environment. The ID values of the test setup diagrams are only examples. The RF connections are set up in a way that all stations can receive each other. All EUTs shall be configured to have their receivers permanently enabled.

8.7.7.2 Basic chaining test with 2 AtoN stations

8.7.7.2.1 Purpose

The purpose of this test section is to verify the basic chaining functions in a simple environment with two AtoN stations.

8.7.7.2.2 Method of measurement

The test scenario shown in Figure 20 shall be set up.

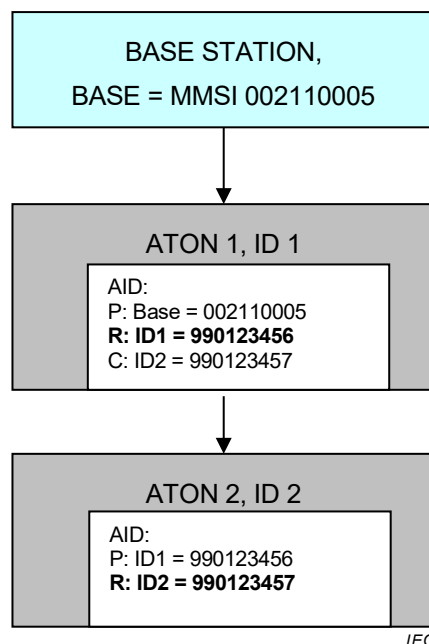

Figure 20 – Test scenario for basic chaining test

- Configure AtoN station 1 with appropriate MMSIs for parent = base, real AtoN = ID1 and child = ID2 using the AID sentence;
- Configure AtoN station 2 with appropriate MMSIs for parent = ID1, real AtoN = ID2 and no child using the AID sentence;
- Send a configuration message from the base station to AtoN 1, source ID = base and MMSI of AtoN = ID1;
- Query the configuration of AtoN 1 and AtoN 2 using PI port sentences;

- e) Send a query message for the applied configuration from the base station to AtoN 1, source ID = base and MMSI of AtoN = ID1;
- f) Send a configuration message from the base station to AtoN 2, source ID = base and MMSI of AtoN = ID2;
- g) Query the configuration of AtoN 1 and AtoN 2 using PI port sentences;
- h) Send a query message for the applied configuration from the base station to AtoN 2, source ID = base and MMSI of AtoN = ID2.

8.7.7.2.3 Required results

Verify:

- a) by query for the AID sentence that the configuration of AtoN 1 is correctly stored;
- b) by query for the AID sentence that the configuration of AtoN 2 is correctly stored;
- c) that AtoN 1 does not retransmit the configuration message;
- d) that the configuration of AtoN 2 is not affected and that AtoN 1 has accepted and stored the new configuration;
- e) that AtoN 1 does not retransmit the query message. Verify that AtoN 1 responds with the requested message, source ID = ID1 and MMSI of AtoN = ID1. Verify that AtoN 2 does not retransmit the query and the response message;
- f) that AtoN 1 retransmits the configuration message, source ID = ID1 and MMSI of AtoN = ID2;
- g) that the configuration of AtoN 1 is not affected and that AtoN 2 has accepted and stored the new configuration;
- h) that AtoN 1 retransmits the query message, source ID = ID1 and MMSI of AtoN = ID2. Verify that AtoN 2 responds with the requested message, source ID = ID2 and MMSI of AtoN = ID2. Verify that AtoN 1 retransmits the response message, source ID = ID1 and MMSI of AtoN = ID2.

8.7.7.3 Configuration by a parent AtoN

8.7.7.3.1 Purpose

The purpose of this test section is to verify that the EUT can be configured and queried by the parent AtoN. In the previous test the EUT receives the message from the base station in addition to the message from AtoN 1. So it is not sure that it has responded on the message from the parent AtoN. Therefore the test is repeated with simulated messages from the parent AtoN, without any messages from the base station.

8.7.7.3.2 Method of measurement

The EUT is only connected to the test environment which simulates the parent AtoN (AtoN 1). AtoN station 2 is configured from the previous test.

- a) Send a message from the test environment to the EUT which simulates a configuration message from AtoN 1 to AtoN 2, source ID = AtoN 2 and MMSI of AtoN = ID2.
- b) Query the configuration of AtoN 2 using PI port sentences.
- c) Send a message from the test environment to the EUT which simulates a query message for the applied configuration from AtoN 1 to AtoN 2, source ID = AtoN 1 and MMSI of AtoN = ID2.

8.7.7.3.3 Required results

Verify that:

- a) the EUT has received the simulated message;
- b) AtoN 2 has accepted and stored the new configuration;

c) AtoN 2 responds with the requested message, source ID = ID2 and MMSI of AtoN = ID2.

8.7.7.4 Chaining test with 3 AtoN stations

8.7.7.4.1 Purpose

The purpose of this test is to verify the chaining functions in a more complex environment consisting of a linear row of three AtoN stations.

8.7.7.4.2 Method of measurement

The test scenario shown in Figure 21 shall be set up.

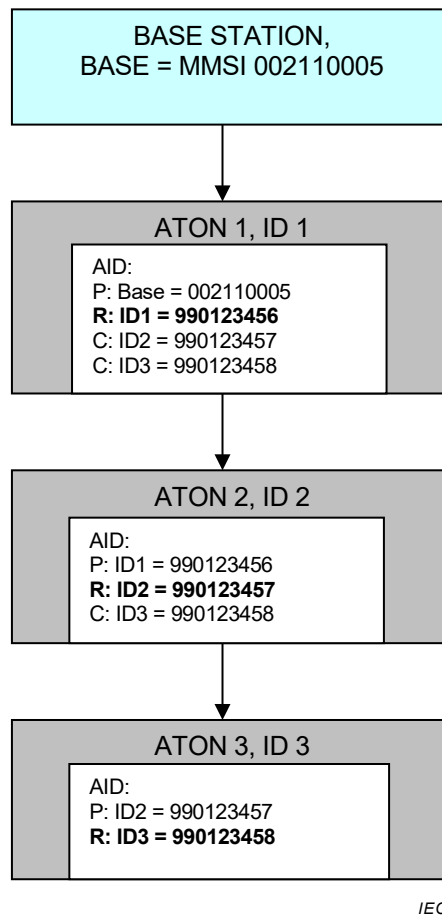

Figure 21 – Test scenario for linear chaining test

- Configure AtoN station 1 with appropriate MMSIs for parent = base, real AtoN = ID1 and child = ID2 and ID3 using the AID sentence.
- Configure AtoN station 2 with appropriate MMSIs for parent = ID1, real AtoN = ID2 and child ID 3 using the AID sentence.
- Configure AtoN station 3 with appropriate MMSIs for parent = ID2, real AtoN = ID3 and no child using the AID sentence.
- Send a configuration message from the base station to AtoN 3, source ID = base and MMSI of AtoN = ID3.
- Query the configuration of AtoN 1, AtoN 2 and AtoN 3 using PI port sentences
- Send a query message for the applied configuration from the base station to AtoN 3, source ID = base and MMSI of AtoN = ID3.

8.7.7.4.3 Required results

Verify:

- by query for the AID sentence that the configuration of AtoN station 1 is correctly stored;
- by query for the AID sentence that the configuration of AtoN station 2 is correctly stored;
- by query for the AID sentence that the configuration of AtoN station 3 is correctly stored;
- that AtoN 1 retransmits the configuration message, source ID = ID1 and MMSI of AtoN = ID3. Verify that AtoN 2 retransmits the configuration message, source ID = ID2 and MMSI of AtoN = ID3;
- that the configuration of AtoN 1 and AtoN 2 is not affected and that AtoN 3 has accepted and stored the new configuration;
- that AtoN 1 retransmits the query message, source ID = ID1 and MMSI of AtoN = ID3. Verify that AtoN 2 retransmits the query message, source ID = ID2 and MMSI of AtoN = ID3. Verify that AtoN 3 responds with the requested message, source ID = ID3 and MMSI of AtoN = ID3. Verify that AtoN 2 retransmits the response message, source ID = ID2 and MMSI of AtoN = ID3. Verify that AtoN 1 retransmits the response message, source ID = ID1 and MMSI of AtoN = ID3. Verify the content of the response message transmitted by AtoN 1.

8.7.7.5 Chaining test with 3 AtoN stations in other configuration

8.7.7.5.1 Purpose

The purpose of this test is to verify the chaining functions in a more complex environment consisting of a forked layout of three AtoN stations.

8.7.7.5.2 Method of measurement

The test scenario shown in Figure 22 shall be set up.

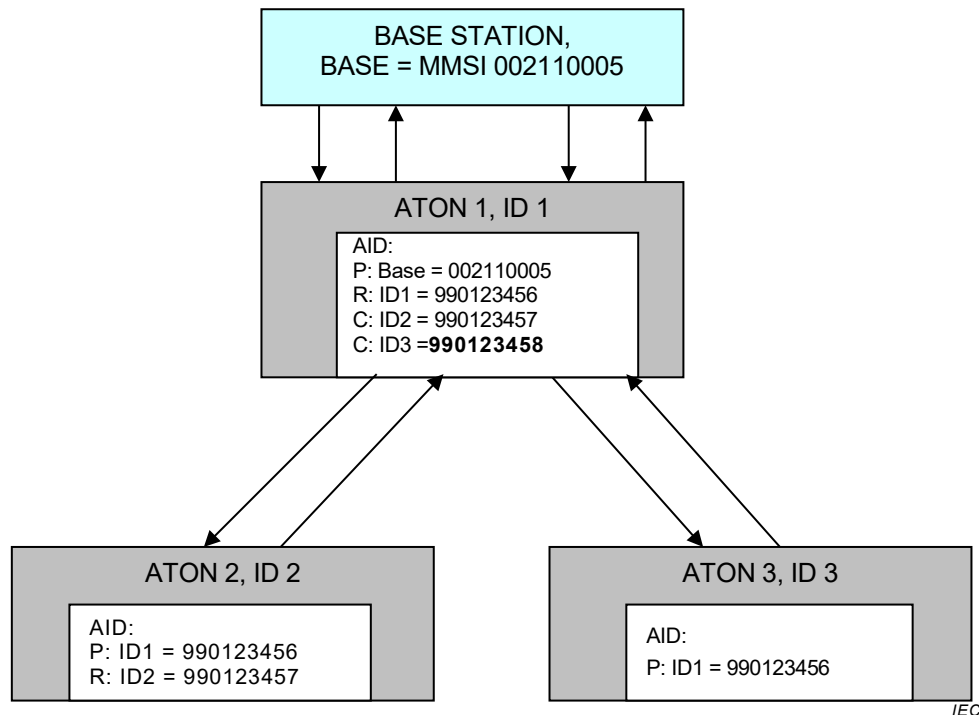

Figure 22 – Test scenario for forked chaining test

- Configure AtoN station 1 with appropriate MMSIs for parent = base, real AtoN = ID1 and child = ID2 and ID3 using the AID sentence.

- b) Configure AtoN station 2 with appropriate MMSIs for parent = ID1, real AtoN = ID2 and no child using the AID sentence.
- c) Configure AtoN station 3 with appropriate MMSIs for parent = ID1, real AtoN = ID3 and no child using the AID sentence.
- d) Send a configuration message from the base station to AtoN 3, Source ID = base and MMSI of AtoN = ID3.
- e) Query the configuration of AtoN 1, AtoN 2 and AtoN 3 using PI port sentences.
- f) Send a query message for the applied configuration from the base station to AtoN 3, Source ID = base and MMSI of AtoN = ID3.

8.7.7.5.3 Required results

Verify:

- a) by query for the AID sentence that the configuration of AtoN 1 is correctly stored;
- b) by query for the AID sentence that the configuration of AtoN 2 is correctly stored;
- c) by query for the AID sentence that the configuration of AtoN 3 is correctly stored;
- d) that AtoN 1 retransmits the configuration message, source ID = ID1 and MMSI of AtoN = ID3. Verify that AtoN 2 does not retransmit the configuration message;
- e) that the configuration of AtoN 1 and AtoN 2 is not affected and that AtoN 3 has accepted and stored the new configuration;
- f) that AtoN 1 retransmits the query message, source ID = ID1 and MMSI of AtoN = ID3. Verify that AtoN 3 responds with the requested message, source ID = ID3 and MMSI of AtoN = ID3. Verify that AtoN 2 does not respond to the query message. Verify that AtoN 2 does not retransmit the response message. Verify that AtoN 1 retransmits the response message, source ID = ID1 and MMSI of AtoN = ID3. Verify the content of the response message transmitted by AtoN 1.

8.7.7.6 Chaining test with Message 6

8.7.7.6.1 Purpose

The purpose of this test is to verify the basic chaining functions with Message 6 instead of Message 25. The test layout of 8.7.7.5 shall be used. It is assumed that the units are already configured according to the layout of 8.7.7.5.

8.7.7.6.2 Method of measurement

The measurement procedure shall be as follows:

- a) send a configuration message from the base station to AtoN 3 via the chain, source ID = base, destination ID = ID1 and MMSI of AtoN = ID3;
- b) query the configuration of AtoN 1, AtoN 2 and AtoN 3 using PI port sentences;
- c) send a query message for the applied configuration from the base station to AtoN 3 via the chain, source ID = base, destination ID = ID1 and MMSI of AtoN = ID3.

8.7.7.6.3 Required results

Verify that:

- a) AtoN 1 retransmits the configuration message, source ID = ID1, destination ID = 0 and MMSI of AtoN = ID3. Verify that AtoN 2 does not retransmit the configuration message;
- b) the configuration of AtoN 1 and AtoN 2 is not affected and that AtoN 3 has accepted and stored the new configuration;
- c) AtoN 1 retransmits the query message, source ID = ID1, destination ID = 0 and MMSI of AtoN = ID3. Verify that AtoN 3 responds with the requested message, source ID = ID3, destination ID = ID1 and MMSI of AtoN = ID3. Verify that AtoN 2 does not respond on the

query message. Verify that AtoN 2 does not retransmit the response message. Verify that AtoN 1 retransmits the response message, source ID = ID1, destination ID = base and MMSI of AtoN = ID3. Verify the content of the response message transmitted by AtoN 1.

8.8 BIIT

8.8.1 Purpose

The purpose of this test is to prove the correct response by the EUT to its BIIT.

8.8.2 Method of measurement

Setup the standard test environment and operate the EUT in normal mode.

- a) Disconnect the antenna from the EUT.
- b) Check the documentation for Tx malfunction
- c) Check the documentation for a fault of the channel 1 receiver (not applicable for type 1).
- d) Check the documentation for a fault of the channel 2 receiver (not applicable for type 1).
- e) Disable the augmentation system, if fitted.

8.8.3 Required results

Verify that:

- a) EUT shall cease transmission, an ADS sentence is output with the alarm status = A, if implemented an ALR sentence with alarm ID = 002 shall be output;
- b) EUT shall cease transmission, an ADS sentence is output with the alarm status = A, if implemented an ALR sentence with alarm ID = 001 shall be output;
- c) EUT shall cease transmission on channel 1, the AtoN health bit shall be set to 1, an ADS sentence is output with the alarm status = A, if implemented an ALR sentence with alarm ID = 003 shall be output;
- d) EUT shall cease transmission on channel 2, the AtoN health bit shall be set to 1, an ADS sentence is output with the alarm status = A, if implemented an ALR sentence with alarm ID = 004 shall be output;
- e) EUT shall continue transmission, the AtoN health bit shall be set to 1, an ADS sentence is output with the alarm status = A, if implemented an ALR sentence with alarm ID = 038 shall be output.

8.9 Transmitter shutdown procedure

8.9.1 Purpose

The purpose of this test is to verify that the transmitter has an automatic shutdown.

8.9.2 Method of measurement

Review the manufacturer's declaration.

8.9.3 Required results

The manufacturer shall provide a declaration in the documentation that states the EUT will function as required.

8.10 Power supply

8.10.1 Purpose

The purpose of this test is to ensure that the power consumption of the AIS AtoN station is as stated in the manufacturer's documentation.

8.10.2 Method of measurement

Setup the standard test environment and operate the EUT in normal mode. Configure reporting of Message 21 to have the following parameters:

- transmit power level: 12,5 W, or the manufacturer's declared level;
- channel 1 slots: 512 and 513;
- channel 2 slots: 612 and 613;
- reporting interval: 3 min.

The test shall be run for 30 min with 10 full duty cycles to measure the average power consumption.

Optionally, repeat the test for RATDMA for the same transmit power and reporting interval.

8.10.3 Required results

Verify that for 10 full duty cycles, the average power consumption of the EUT does not exceed 110 % of the value stated in the manufacturer's documentation.

8.11 Environmental

Tests shall be carried out in accordance with IEC 60945, *Durability and resistance to environmental conditions*, protected or exposed, or as defined by manufacturer.

8.12 External removable media

8.12.1 Purpose

To ensure the number of external connection points are minimized and protected.

8.12.2 Method of measurement

Review manufacturer's documentation.

8.12.3 Required results

Refer to the device manufacturer's documentation and confirm by inspection of the documented evidence that the number of connection points for REDS (USB ports, disc drives, etc.) are those required by the manufacturer for operation, lifetime maintenance and support. Confirm by observation that all other connection points are blocked or disabled in accordance with the information provided by the manufacturer.

8.13 Other tests

8.13.1 Quality assurance

The manufacturer shall declare the quality assurance standard to which the EUT is manufactured.

8.13.2 Additional features

The manufacturer shall declare any additional features of the EUT. These features are not tested in accordance with this standard. The manufacturer's declaration shall confirm that additional features, including position accuracy augmentation, do not adversely affect Message 21 transmissions.

8.13.3 Manual

The manual shall include information concerning:

- external connectors, if applicable;
- correct installation of the unit and antennae;
- configuration;
- power consumption;
- firmware upgrades, if applicable;
- configuration interface, including hardware and electrical details.

8.13.4 Marking and identification

Verify that marking and identification complies with 5.5.3.

8.14 Optional TAG block encapsulation

8.14.1 Application

This test will verify that the AIS AtoN can respond to TAG blocks and generate TAG blocks properly as defined in Table 16.

In most tests a query for a VER sentence and a VER response is used. This can be replaced by other sentences which initiate a response by the EUT.

Only tests of functions which are implemented have to be performed.

8.14.2 TAG block capabilities

8.14.2.1 Purpose

This test verifies that the EUT responds to a request from a TBR sentence with output sentences providing the correct capability information.

8.14.2.2 Method of measurement

Set up the standard test environment and use the configuration as defined in 8.1.2.

- a) Apply a TBR (TAG block report request) sentence to the EUT with the correct unique identifier (UI) of the EUT and the request flag set to “S” requesting all supported TAG block functions.
- b) Apply a query for TBS.

8.14.2.3 Required results

Confirm that:

- a) the EUT outputs the sentences CPD, CPG, CPS, CPC and CPN with talker and listener function field set to “V” (supported but disabled). The listener function of CPC, CPG and CPS can be set to “U” (unsupported) depending on the implementation;
- b) there is one TBS output with the source-identification field set to null field.

8.14.3 Activation of source-identification for output

8.14.3.1 Purpose

This test verifies that the EUT provides the correct TAG blocks containing the source-identification with the output sentences, depending on the configuration.

8.14.3.2 Method of measurement

Set-up the standard test environment and use the configuration as defined in 8.1.2.

- a) Apply a CPS sentence (configure parameter code for the source identification parameters) to the EUT, with the talker source-identification function set to "N" (enabled for NAK reply only) and the listener source-identification function set to "V" (disabled). Apply a TBR sentence.
- b) Apply a sentence to the EUT which causes a NAK response. The manufacturer shall provide information on how to get a NAK response.
- c) Apply a CPS sentence to the EUT, with the talker source-identification function set to "A" (enabled) and the listener source-identification function set to "V" (disabled). Apply a TBR sentence.
- d) Apply a query for a VER sentence.

8.14.3.3 Required results

Confirm that:

- a) the EUT outputs a CPS sentence with the correct settings and the sentence status flag set to "R" (report); confirm that the output does not include TAG blocks;
- b) the EUT outputs a NAK sentence with a preceding correct TAG block, including the Source-identification parameter set to the own unique identifier (applied by SID sentence);
- c) the EUT outputs a CPS sentence with the correct settings, with a TAG block where source identification = own UI; confirm that all sentences are output with TAG blocks containing a source identification;
- d) a VER sentence is output with a TAG block where source identification = own UI.

8.14.4 Activation of Destination-identification

8.14.4.1 Purpose

This test verifies that the EUT provides the correct destination identification with the output sentences and performs the correct filtering of input sentences with TAG blocks containing a destination identification parameter.

8.14.4.2 Method of measurement

Set up the standard test environment and use the configuration as defined in 8.1.2.

- a) Apply a CPD sentence (configure parameter code for the destination identification parameters) without TAG block to the EUT, with the talker destination identification function set to "A" (enabled) and the listener destination identification function set to "V" (disabled). Apply a TBR sentence.
- b) Apply a query for VER, without a TAG block.
- c) Apply a query for VER, with a TAG block containing a source identification and the correct destination identification (UI of EUT).
- d) Apply a query for VER, with a TAG block containing a source identification and a destination identification different to the UI of EUT.
- e) Apply a CPD sentence to the EUT, with the talker destination identification function set to "A" (enabled) and the listener destination identification function set to "A" (enabled). Apply a TBR sentence with the correct source and destination identification.
- f) Apply a query for VER, without a TAG blocks.
- g) Apply a query for VER, with a TAG block containing a source identification and the correct destination identification (UI of EUT).
- h) Apply a query for VER, with a TAG block containing a source identification and a destination identification different to the UI of EUT.

8.14.4.3 Required results

Confirm that:

- a) the EUT outputs a CPD sentence with the correct settings. Confirm that the output sentence is preceded by a TAG block with source-identification = own UI and no destination-identification. Confirm that all output sentences which are not a response on an input sentence do not include a destination-identification in the TAG block.
- b) a VER sentence is output with a TAG block where source-identification = own UI and no destination-identification;
- c) a VER sentence is output with a TAG block where source-identification = own UI and the destination-identification = source-identification of the query TAG block;
- d) a VER sentence is output with a TAG block where source-identification = own UI and the destination-identification = source-identification of the query TAG block;
- e) the EUT outputs a CPD sentence with the correct settings. Confirm that the output sentence is preceded by a TAG block where source-identification = own UI and destination-identification = source-identification of the TAG block of the input TBR sentence;
- f) there is no VER response;
- g) a VER sentence is output with a TAG block where source-identification = own UI and the destination-identification = source-identification of the query TAG block;
- h) there is no VER response.

8.14.5 Activation of Source-identification for input

8.14.5.1 Purpose

8.14.5.1.1 General

This test verifies the correct storage of source-identification parameters and the correct input filtering by source-identification parameters in input TAG blocks.

8.14.5.1.2 Method of measurement

Set-up the standard test environment and use the configuration as defined in 8.1.2. Activate destination-identification for output as in 8.14.4.2 a).

- a) Apply a TBS sentence to the EUT containing a valid source-identification S1, the action field set to 1 = add the provided source-identification value. Query for TBS.
- b) Apply a query for VER, with a TAG block containing a source-identification different to the stored source-identification S1.
- c) Apply a CPS sentence to the EUT, with the talker source-identification function set to "A" (enabled) and the listener source-identification function set to "A" (enabled). Apply a TBR sentence with a source-identification S1.
- d) Apply a query for VER, with a TAG block not containing a source-identification parameter.
- e) Apply a query for VER, with a TAG block containing a source-identification equal to the stored source-identification S1.
- f) Apply a query for VER, with a TAG block containing a source-identification different to the stored source-identification S1.
- g) Apply a query for VER, with a TAG block containing a source-identification "DEFAULTSOURCE".

8.14.5.2 Required results

Confirm that:

- a) the EUT outputs a TBS sentence with the correct source-identification S1. Confirm that there is no TBS output sentence for the source-identification of "DEFAULTSOURCE";
- b) there is a VER response;
- c) the EUT outputs a CPS sentence with the correct activation settings talker = A and listener = A;
- d) there is no VER response;
- e) there is a VER response with a destination-identification which is identical to the source-identification of the query sentence;
- f) there is no VER response;
- g) there is a VER response without destination-identification.

8.14.6 Use of multiple source-identifications for input

8.14.6.1 Purpose

This test verifies the correct storage of multiple source-identifications and the correct input filtering by source-identification parameters in input TAG blocks.

8.14.6.2 Method of measurement

Set-up the standard test environment and use the configuration as defined in 8.1.2. Activate destination-identification for output as in 8.14.4.2 a).

- a) Apply TBS sentences to the EUT containing valid source-identification S2, S3, ..., Sn according to the maximum number of source-identifications provided by the manufacturer. The CPS of setting of S1 from the previous test is still valid. Query for TBS using a valid source-identification in the TAG block.
- b) Apply query sentences for VER, one query for each applied source-identification with a TAG block containing the appropriate source-identification.
- c) Apply a query for VER, with a TAG block containing a source-identification which is not part of the stored source-identifications.
- d) Apply one more TBS sentence which would exceed the maximum number of source-identifications which can be stored by the EUT. Query for TBS.
- e) Apply a TBS sentence to the EUT containing the source-identification S2 as applied in test a) with the action field set to 2 (remove the provided source-identification). Query for TBS.
- f) Apply a TBS sentence to the EUT containing no source-identification value, with the Action field set to 3 (remove all source-identifications). Query for TBS.
- g) Apply a query sentence for VER, with a TAG block containing the source-identification value "DEFAULTSOURCE".

8.14.6.3 Required results

Confirm that:

- a) the EUT outputs a TBS sentence with the correct source-identifications S1, S2, S3, ..., Sn for each applied TBS sentence. Confirm that at least 5 Source-identifications can be stored. Confirm that there is no TBS output sentence for the source-identification of "DEFAULTSOURCE";
- b) there is a VER response for each query, with destination-identification = source-identification of the query TAG block;
- c) there is no VER response;
- d) there is a NAK response on the TBS sentence indicating that the source-identification cannot be stored. Confirm that there is a TBS sentence for source-identification S1 and for each source-identification stored under step a);

- e) the EUT outputs a TBS sentence with the correct source-identification S1,S3, ..., Sn for each stored source-identification. Confirm that there is no TBS output sentence for the source-identification S2 which has been removed;
- f) there is one TBS output with the source-identification field set to null field;
- g) there is a VER response. This indicates that the default source-identification "DEFAULTSOURCE" has not been deleted.

8.14.7 Test of grouping by TAG blocks for output

8.14.7.1 Purpose

This test verifies the grouping of sentences using TAG block grouping parameter "g:" for output sentences.

8.14.7.2 Method of measurement

Set up the standard test environment and use the configuration as defined in 8.1.2.

- a) Apply a CPS and a CPD sentence to disable Source-identification and destination-identification (talker and listener function set to "V"). Apply a TBR sentence with the request flag set to "S" requesting all supported TAG block functions.
- b) Input an SPO sentence to activate VSI sentences for VDM.
- c) Apply a CPG sentence to activate the talker grouping function (talker function set to "A" and listener function set to "V"). Set the reset event to "0" = use the group-code limit. Set the initial group-code and the group-code increment to 1 (default). The group-code limit is set to a small integer value (e.g.10). Apply a TBR sentence.

The following tests are performed only if the optional functions are implemented.

- d) Apply a CPG sentence with talker function set to "A" and listener function set to "V". Set the reset event to "0" = use the group-code limit. Set the initial group-code to 100 and the group-code increment to 10. The group-code limit is set to 250. Apply a TBR sentence.
- e) Apply an SPO sentence to activate VSI sentences for VDM and VDO. Apply a CPD and CPS sentence to activate destination-identification and source-identification for talker. Apply a CPG sentence to activate the talker grouping function (talker function set to "A" and listener function set to "V"). Set the reset event to "3" = every minute. Set the initial group-code to 200 and the group-code increment to -5. The event offset value is set to -10. Apply a TBR sentence.

8.14.7.3 Required results

Confirm that:

- a) the EUT outputs the sentences CPD, CPG, CPS, CPN and CPC with talker and listener function field set to "V" (supported but disabled). The listener function of CPC, CPG and CPC can be set to "U" (unsupported) depending on the implementation;
- b) the EUT outputs VSI sentences together with all VDM sentences. Confirm that no TAG blocks are added;
- c) the response on TBR includes a CPG sentence with the input parameters. Confirm that single line sentences (e.g. VDO) are output without TAG blocks. Confirm that all VSI/VDM combinations and all multi-part VDM and VDO sentences are grouped using TAG blocks. Confirm that the x parameter in the g: string starts with 1 and is incremented by 1 for each sentence in a group. Confirm that the y parameter is identical for each sentence in a group and indicates the total number of sentences of this group. Confirm that the code parameter is identical for each sentence in a group and is incremented by the defined group-code increment parameter (= 1) for each group. Confirm that the code parameter is reset to the defined Initial group code (= 1) when it would exceed the defined group-code limit (e.g. = 10);

- d) the TBR response includes a CPG sentence with the input parameters. Confirm that all VSI/VDM combinations and multi-part VDM and VDO messages are grouped using TAG blocks with the correct parameters. Confirm that the x parameter in the g: string starts with 1 and is incremented by 1 for each sentence in a group. Confirm that the y parameter is identical for each sentence in a group and indicates the total number of sentences of this group. Confirm that the code parameter is identical for each sentence in a group and is incremented by the defined group-code increment parameter (= 10) for each group. Confirm that the code parameter is reset to the defined Initial group code (= 100) when it would exceed the defined group-code limit (= 250);
- e) the TBR response includes a CPG sentence with the input parameters. Confirm that all VSI/VDM and VSI/VDO combinations and multi-part VDM and VDO messages are grouped using TAG blocks with the correct parameters. Confirm that the grouping parameter is always the first parameter in a TAG block. Confirm that the x parameter in the g: string starts with 1 and is incremented by 1 for each sentence in a group. Confirm that the y parameter is identical for each sentence in a group and indicates the total number of sentences of this group. Confirm that the code parameter is identical for each sentence in a group and is decremented by the defined group-code increment parameter (= -5) for each group. Confirm that the code parameter is reset to the defined Initial group code (= 200) 10 s (Event offset parameter) before the beginning of each minute.

8.14.8 Test of UNIX time output

8.14.8.1 Purpose

This test verifies the output of the TAG block parameter "c" with the UNIX time value.

8.14.8.2 Method of measurement

Set up the standard test environment and use the configuration as defined in 8.1.2.

- a) Apply a CPC sentence (configure parameter-code for UNIX time parameter) with the talker UNIX time function set to "A" (enabled) and the listener UNIX time function set to "V" (disabled). The time precision/format parameter shall be set to 1 = integer seconds. Apply a TBR sentence. Activate grouping as defined in 8.14.7.2 c).
- b) Apply a CPC sentence with the talker UNIX time function set to "A" (enabled) and the time precision/format parameter set to 2 = integer milliseconds.

8.14.8.3 Required results

Confirm that:

- a) the response of the EUT includes the CPC sentences with the parameters set according to the CPC input and the Sentence status flag set to "R". Confirm that each ungrouped output TAG block contains the c: parameter with the correct UNIX time in seconds. Confirm that in each TAG block group at least one TAG block contains the c: parameter with the correct UNIX time in seconds;
- b) a NAK is output on the PI as a response to the CPC indicating that the EUT does not support millisecond resolution for the UNIX time. If no NAK is output then confirm that each ungrouped output TAG block contains the c: parameter with the UNIX time in milliseconds. Confirm that in each TAG block group at least one TAG block contains the c: parameter with the UNIX time in milliseconds. Required accuracy shall be ± 1 s.

8.14.9 Test of line-count output

8.14.9.1 Purpose

This test verifies the output of the TAG block parameter "n" with the correct line number.

8.14.9.2 Method of measurement

Set up the standard test environment and use the configuration as defined in 8.1.2.

- a) Enable the talker grouping function and disable the source-identification and destination-identification. Input an SPO sentence to inactivate VSI sentences for VDO. Apply a CPN sentence (configure parameter-code for the line-count parameter) with the talker line-count function set to "A" (enabled) and the listener line-count function set to "V" (disabled). The other parameters shall be set to: reset event = 0 (use the line-count limit), initial line-count = 1, count increment = 1, line-count limit = 20, event offset = null field. Apply a TBR sentence.

The following tests are performed only if the optional functions are implemented.

- b) Apply a CPN sentence with the following parameters: talker line-count function enabled, reset event = 0 (use the line-count limit), initial line-count = 3000, count Increment = -100, line-count limit = 1000, event offset = null field.
- c) Apply a CPN sentence with the following parameters: talker Line-count function enabled reset event = 2 (hourly), initial line-count = 100, count Increment = 10, line-count limit = null field, event offset = 30.

8.14.9.3 Required results

Confirm that:

- a) the response of the EUT includes the CPN sentence with the parameters set according to the CPN input and the sentence status flag is set to "R". Confirm that each sentence is preceded by a TAG block. Confirm that each TAG block including each TAG block of a group contains an "n" -parameter. Confirm that the line-count is incremented for each occurrence by one. Confirm that the line-count is reset to 1 when it would exceed the line-count limit;
- b) each sentence is preceded by a TAG block containing an "n" parameter. Confirm that the line-count starts with 3000. Confirm that the line-count is decremented for each occurrence by 100. Confirm that the line-count is reset to 3000 when it would be less than the line-count limit of 1000;
- c) each sentence is preceded by a TAG block containing an "n" parameter. Confirm that the line-count starts with 100. Confirm that the line-count is incremented for each occurrence by 10. Confirm that the line-count is reset to 100 thirty seconds after the beginning of each hour.

Annex A (informative)

AIS AtoN station configuration structures

A.1 AIS AtoN station configuration structures

This annex defines the binary data fields of VDL Messages 6 and/or 25 used by AIS AtoN stations to establish a communication protocol that allows for secure communication between AIS AtoN stations and base stations. This communication can establish a chain of AIS AtoN stations allowing for communication with AIS AtoN stations that are remote and unable to communicate directly with the base station. The tables in this annex only describe the binary data fields. The choice of Message 6 or 25 is left to the competent authority, however query messages shall be responded to with the same message type (i.e. 6 for 6 and 25 for 25).

The AIS AtoN station uses Message 25, or Message 6, with an AES encrypted binary data field for secure communication. Message 25 requires one slot for the 128-bit boundary required for AES encrypted data in the binary data field. Message 6 requires two slots for the 128-bit boundary required for AES encrypted data in the binary data field. The 8-bit AIS encryption checksum in all messages is calculated according to CRC-8-CCITT. The generator polynomial is $x^8 + x^2 + x^1 + 1$ as defined in ISO/IEC 13239:2002.

When a query specifies a start slot, it shall be used for the first response message. Additional response messages shall use RATDMA. A start slot value of 2 250 indicates RATDMA is to be used for all responses.

Tables A.1 and A.2 provide the parameter settings and Table A.3 the function identifiers.

Table A.1 – Parameter setting in Message 25 for AIS AtoN Station applications

Parameter	Number of bits	Description
Message ID	6	Identifier for Message 25; always 25
Repeat indicator	2	Set to 0 (is not changed by intermediate AIS AtoN Stations in a chain)
Source ID	30	MMSI of station broadcasting message (changed by intermediate AIS AtoN stations in a chain)
Destination indicator	1	Set to 0 (is not changed by intermediate AIS AtoN stations in a chain)
Binary data flag	1	Set to 0 (is not changed by intermediate AIS AtoN stations in a chain)
Binary data	128	AES encrypted binary data; 120 bits of data 8 bits AES checksum
Total number of bits	168	Occupies 1 slot

Table A.2 – Parameter setting in Message 6 for AIS AtoN Station applications

Parameter	Number of bits	Description
Message ID	6	Identifier for Message 6; always 6
Repeat indicator	2	Set to 0 (is not changed by intermediate AIS AtoN stations in a chain)
Source ID	30	MMSI of station broadcasting message (changed by intermediate AIS AtoN stations in a chain)
Sequence number	2	Set to 0 (is not changed by intermediate AIS AtoN stations in a chain)
Destination ID	30	Set to the MMSI of the receiver, set to 0 if receiver is not known
Retransmit flag	1	Set to 0 (is not changed by intermediate AIS AtoN stations in a chain)
Spare	1	Not used. Should be zero. Reserved for future use.
Binary data	144	Application identifier (16 bits)
		AES encrypted binary data (128 bits)
Total number of bits	216	Occupies 2 slots

Table A.3 – Message 25 or 6 function identifier used for configuration and query via the VDL

Function identifier	Description	Type
000000 (dec 0)	MMSI identification configuration (AID)	Configuration
000001 (dec 1)	Query for AtoN MMSIs	Query – request
000010 (dec 2)	Query response for AtoN MMSIs	Query -response
000011 (dec 3)	General AtoN configuration (ACF/ACG) part 1	Configuration
000100 (dec 4)	General AtoN configuration (ACF/ACG) part 2	Configuration
000101 (dec 5)	General AtoN configuration (ACF/ACG) part 3	Configuration
000110 (dec 6)	General AtoN configuration (ACG) part 4 First 12 characters of AtoN name	Configuration
000111 (dec 7)	General AtoN configuration (ACG) part 5 Second 12 characters of AtoN name	Configuration
001000 (dec 8)	General AtoN configuration (ACG) part 6 Third (last) 10 characters of AtoN name	Configuration
001001 (dec 9)	Query for general AtoN configuration	Query – request
001010 (dec 10)	Query response general AtoN configuration part 1	Query -response
001011 (dec 11)	Query response general AtoN Configuration part 2	Query -response
001100 (dec 12)	FATDMA broadcast rates configuration (CBR)	Configuration
001101 (dec 13)	RATDMA broadcast rates configuration (CBR)	Configuration
001110 (dec 14)	Query for AtoN broadcast rates	Query -request
001111 (dec 15)	Query response AtoN broadcast rates	Query -response
010000 (dec 16)	Configuration encryption key (CEK)	Configuration
010001 (dec 17)	Configuration receiver on times (ARW) Not used in edition 2, replaced by FI35	Configuration
010010 (dec 18)	Query for receiver on times Not used in edition 2, replaced by FI34	Query -request
010011 (dec 19)	Query response receiver on times Not used in edition 2, replaced by FI36	Query -response
010100 (dec 20)	Manufacturer's AtoN control (MCR) Not used in edition 2	Functional
010101 (dec 21)	Query for manufacturer's AtoN control Not used in edition 2	Query -request
010110 (dec 22)	Query response manufacturer's AtoN control Not used in edition 2	Query -response
010111 (dec 23)	Message payload for broadcast (MPR) Not used in edition 2, replaced by FI37/38	Functional
011000 (dec 24)	Force a broadcast (AFB)	Functional
011001 (dec 25)	Query for version information (VER)	Query – request
011010 (dec 26)	Query response version information	Query – response
011011 (dec 27)	Query for AtoN function ID capability	Query – request
011100 (dec 28)	Query response AtoN function ID capability	Query – response
011101 (dec 29)	AIS AtoN prohibited slots (TSP) Not used in edition 2	Configuration

Function identifier	Description	Type
011110 (dec 30)	Query for AIS AtoN prohibited slots Not used in edition 2	Query – request
011111 (dec 31)	Query response AIS AtoN prohibited slots Not used in edition 2	Query – response
100000 (dec 32)	Query for Message 21 content Not used in edition 2	Query – request
100001 (dec 33)	Query response Message 21 content Not used in edition 2, replaced by FI 39-42	Query – response
100010 (dec 34)	General query request message	Query – request
100011 (dec 35)	Configuration of receiver operational times (COP)	Configuration
100100 (dec 36)	Query response receiver operational times	Query – response
100101 (dec 37)	Payload control configuration for broadcast MEB	Configuration
100110 (dec 38)	Payload binary data for broadcast MEB	Configuration
100111 (dec 39)	Query response Message 21 data configuration	Query – response
101000 (dec 40)	Query response AtoN name part 1	Query – response
101001 (dec 41)	Query response AtoN name part 2	Query – response
101010 (dec 42)	Query response AtoN name part 3	Query – response
NOTE For the application identifier the DAC is always 990 for an AIS AtoN station.		

A.2 MMSI Identification configuration command (AID)

This structure is used to load, for an AtoN station, its real, virtual and chained MMSI(s). Each AtoN station will maintain a table of its MMSI(s) and the messages associated with these MMSI(s).

The parameters are given in Tables A.4, A.5 and A.6.

Table A.4 – Configuration via the VDL for MMSI identification

Parameter	Number of bits	Description
Application identifier	16	Bits 15-6= $1111011110_2 = 990_{10}$ Bits 5-0 = $000000_2 = 00_{10}$ Function identifier for changing or creating MMSI numbers
MMSI of addressed AtoN	30	MMSI of the station being addressed the initial factory setting should be defined by manufacturer. All real AtoNs should receive initial MMSI configuration in a lab not over the VDL.
Create/delete	1	Define if the MMSI is being created/changed (1) or deleted (0). If own station MMSI is deleted, it should revert to the initial factory setting. If a virtual AtoN is deleted, then all associated messages for that virtual AtoN are also deleted.
MMSI of AtoN	30	MMSI to be created/changed/or deleted.
Virtual, real or chained	2	00 own station (real), 01 virtual (synthetic), 10 chained parent, 11 chained child. Real is own station, chained indicates to an MMSI that this station is responsible for relaying messages to and from, a virtual AtoN indicates to an MMSI that this station is responsible for generating at least a Message 21.
Spare	41	Spare bits needed for 120-bit message content.
AES encryption checksum	8	Required for AES algorithm.
Total bits	128	

Table A.5 – Query via the VDL for MMSI identification

Parameter	Number of bits	Description
Application identifier	16	Bits 15-6 = $1111011110_2 = 990_{10}$ Bits 5-0 = $000001_2 = 01_{10}$ Function identifier to query for a list of all AtoN MMSIs and types.
MMSI of AtoN	30	MMSI of AtoN
Channel selection	1	0 – indicates channel 1 1 – indicates channel 2 The query response will only be sent on a single channel.
UTC hour for start slot	5	0-23; 24 = RATMDA is used all other FATDMA fields ignored; 25-31 not used
UTC minute for start slot	6	0-59; 60 = UTC minute not available = default; 61-63 not used
Start slot	12	Starting slot for the query response
Spare	50	Spare bits needed for 120 bit message content
AES encryption checksum	8	Required for AES algorithm
Total bits	128	

Table A.6 – Query response via the VDL for MMSI identification

Parameter	Number of bits	Description
Application identifier	16	Bits 15-6 = $1111011110_2 = 990_{10}$ Bits 5-0 = $000010_2 = 02_{10}$ Function identifier answer to query for AtoN lists
MMSI of AtoN	30	MMSI of responding AtoN
Number of MMSI's to report	10	The total number of MMSI that will be reported – could take multiple responses to report all known AtoNs – competent authority responsible for reserving enough slots.
MMSI	30	MMSI of AtoN.
Virtual, real or chained	2	00 own station (real), 01 virtual (synthetic), 10 chained parent, 11 chained child
MMSI	30	MMSI of AtoN
Virtual, real or chained	2	00 own station (real), 01 virtual (synthetic), 10 chained parent, 11 chained child.
Spare	0	Spare bits needed for 120-bit message content
AES encryption checksum	8	Required for AES algorithm
Total bits	128	

A.3 Extended/general AtoN station configuration command (ACF/ACG)

The ACF and the ACG structures are used to configure the AtoN station parameters when it is initially installed, and later in order to make changes to the way it operates. This structure supports the system administration of the AIS AtoN station operation.

The parameters for configuration are given in Tables A.7 to A.12.

The parameters for a query via the VDL for extended/general AtoN station configuration are given in Tables A.13 to A.15. These additional functional queries are to be used to obtain setup information not contained within the Message 21.

Table A.7 – Configuration via the VDL, Part 1

Parameter	Number of bits	Description
Application identifier	16	Bits 15-6 = $1111011110_2 = 990_{10}$ Bits 5-0 = $000011_2 = 03_{10}$ Function identifier for Message 21 content
MMSI of AtoN	30	MMSI of AtoN
Position accuracy	1	1 = high; 0 = low = default
Lat	27	Latitude in 1/10 000 min of aids-to-navigation ($\pm 90^\circ$, north = positive, south = negative, 91 = (3412140h) = not available = default)
Lon	28	Longitude in 1/10 000 min of position of aids-to-navigation ($\pm 180^\circ$, east = positive, west = negative, 181 = (6791AC0h) = not available = default)
EPFS type	4	As defined in ITU-R M.1371
Off-position threshold	12	Off-position indicator is generated when this threshold is exceeded (distance in metres)
Acknowledgement procedure	1	Determines behaviour for message acknowledgement 0 = will provide acknowledgement as defined by manufacturer 1 = will not providing acknowledgement
Spare	1	Spare bits needed for 120-bit message content
AES encryption checksum	8	Required for AES algorithm
Total bits	128	

Table A.8 – Configuration via the VDL, Part 2

Parameter	Number of bits	Description
Application identifier	16	Bits 15-6 = $1111011110_2 = 990_{10}$ Bits 5-0 = $000100_2 = 04_{10}$ Function identifier for Message 21 content
MMSI of AtoN	30	MMSI of AtoN
Type of AtoN	5	0 = not available = default; refer to appropriate definition set up in ITU-R M.1371
Dimensions	30	Reference point for reported position; also indicates the dimension of aids-to-navigation (see ITU-R M.1371) Should be given as aaabbbccdd
AtoN status bits	8	Indication of the AtoN status, default "00000000 ₂ "
Virtual AtoN flag	2	0 = real 1 = virtual AtoN 2 = synthetic AtoN (flag remains 0 in Message 21 but the repeat indicator should be > 0)
Spare	29	Spare bits needed for 120-bit message content
AES encryption checksum	8	Required for AES algorithm
Total bits	128	

Table A.9 – Configuration via the VDL, Part 3

Parameter	Number of bits	Description
Application identifier	16	Bits 15-6 = $1111011110_2 = 990_{10}$ Bits 5-0 = $000101_2 = 05_{10}$ Function identifier for Message 21 content
MMSI of AtoN	30	MMSI of AtoN
Receive channel 1	12	25 kHz channel number according to Recommendation ITU-R M.1084
Receive channel 2	12	25 kHz channel number according to Recommendation ITU-R M.1084
Transmit channel 1	12	25 kHz channel number according to Recommendation ITU-R M.1084
Transmit channel 2	12	25 kHz channel number according to Recommendation ITU-R M.1084
Power level	4	0 = default manufacturer power level (nominally 12,5 W) 1 to 9 as defined by the manufacturer
Off-position behaviour	1	0 – maintain current broadcast schedule 1 – use New Reporting Rate
Synch lost behaviour	1	0 –go silent 1 – continue as before
Spare	20	Spare bits needed for 120-bit message content
AES encryption checksum	8	Required for AES algorithm
Total bits	128	

Table A.10 – Configuration via the VDL, Part 4 (first 12 characters of AtoN name)

Parameter	Number of bits	Description
Application identifier	16	Bits 15-6 = $1111011110_2 = 990_{10}$ Bits 5-0 = $000110_2 = 06_{10}$ Function identifier for Message 21 content First 12 characters of AtoN name
MMSI of AtoN	30	MMSI of AtoN
Name of AtoN	72	First 12 characters of 34 characters for name of AtoN
Spare	2	Spare bits needed for 120-bit message content
AES encryption checksum	8	Required for AES algorithm
Total bits	128	

Table A.11 – Configuration via the VDL, Part 5 (second 12 characters of AtoN name)

Parameter	Number of bits	Description
Application identifier	16	Bits 15-6 = $1111011110_2 = 990_{10}$ Bits 5-0 = $000111_2 = 07_{10}$ Function identifier for Message 21 content, second 12 characters of AtoN name
MMSI of AtoN	30	MMSI of AtoN
Name of AtoN	72	Second 12 characters of 34 characters for name of AtoN
Spare	2	Spare bits needed for 120-bit message content
AES encryption checksum	8	Required for AES algorithm
Total bits	128	

Table A.12 – Configuration via the VDL, Part 6 (third (last) 10 characters of AtoN name)

Parameter	Number of bits	Description
Application identifier	16	Bits 15-6 = $1111011110_2 = 990_{10}$ Bits 5-0 = $001000_2 = 08_{10}$ Function identifier for Message 21 content, last 10 characters of AtoN name
MMSI of AtoN	30	MMSI of AtoN
Name of AtoN	60	Last 10 characters of 34 characters for name of AtoN
Spare	14	Spare bits needed for 120-bit message content
AES encryption checksum	8	Required for AES algorithm
Total bits	128	

Table A.13 – Query request via the VDL

Parameter	Number of bits	Description
Application identifier	16	Bits 15-6 = $1111011110_2 = 990_{10}$ Bits 5-0 = $001001_2 = 09_{10}$ Function identifier for query for ACF/ACG content query
MMSI of AtoN	30	MMSI of AtoN
Channel selection	1	0 – indicates channel 1 1 – indicates channel 2 The query response will only be sent on a single channel
UTC hour for start slot	5	0-23; 24 = RATMDA is used all other FATDMA fields ignored; 25-31 not used
UTC minute for start slot	6	0-59; 60 = UTC minute not available = default; 61-63 not used
Start slot	12	Starting slot for the query response
Spare	50	Spare bits needed for 120-bit message content
AES encryption checksum	8	Required for AES algorithm
Total bits	128	

Table A.14 – Query response via the VDL, Part 1

Parameter	Number of bits	Description
Application identifier	16	Bits 15-6 = $1111011110_2 = 990_{10}$ Bits 5-0 = $001010_2 = 10_{10}$ Function identifier for answer to query for ACF and ACG part 1 providing the following: off-position threshold LAT LON invalid position behaviour UTC sync loss behaviour channel operation power level
MMSI of AtoN	30	MMSI of responding AtoN
Off-position threshold	12	Off-position indicator is generated when this threshold is exceeded (distance in metres)
LAT	27	Latitude in 1/10 000 min of aids-to-navigation ($\pm 90^\circ$, north = positive, south = negative, $91 = (3412140_h) = \text{not available} = \text{default}$)
LON	28	Longitude in 1/10 000 min of position of aids-to-navigation ($\pm 180^\circ$, east = positive, west = negative, $181 = (6791AC0_h) = \text{not available} = \text{default}$)
Behaviour for sync loss	1	0 = go silent 1 = continue as before
Power level	4	0 = default manufacturer power level (nominally 12,5 W) 1 to 9 as defined by the manufacturer
Spare	2	Spare bits needed for 120-bit message content
AES encryption checksum	8	Required for AES algorithm
Total bits	128	

Table A.15 – Query response via the VDL, Part 2

Parameter	Number of bits	Description
Application identifier	16	Bits 15-6 = $1111011110_2 = 990_{10}$ Bits 5-0 = $001011_2 = 11_{10}$ Function identifier for answer to query for ACF and ACG Part 2 providing the following: off-position behaviour slot interval when off position receive channel 1 receive channel 2 transmit channel 1 transmit channel 2
MMSI of AtoN	30	MMSI of responding AtoN
Off-position behaviour	1	0 = maintain current broadcast schedule 1 = use new reporting rate
Receive Channel 1	12	25 kHz channel number according to Recommendation ITU-R M.1084
Receive Channel 2	12	25 kHz channel number according to Recommendation ITU-R M.1084
Transmit Channel 1	12	25 kHz channel number according to Recommendation ITU-R M.1084
Transmit Channel 2	12	25 kHz channel number according to Recommendation ITU-R M.1084
Spare	25	Spare bits needed for 120-bit message content
AES encryption checksum	8	Required for AES algorithm
Total bits	128	

A.4 Configure broadcast rates for AtoN Station message command (CBR)

This structure assigns the schedule of slots that will be used to broadcast Message 21 and other allowed AIS AtoN station messages. It provides the start slot and interval between the slots used for consecutive transmissions for the message. The AIS AtoN station should apply the information provided by this structure to autonomously and continuously transmit the VDL messages until revised by a new CBR structure.

The AIS AtoN station, upon receipt of a query for this information, will generate structures for configured messages providing the current broadcast schedule. New broadcast rate assignments will override existing CBR assignments.

The parameters are given in Tables A.16 to A.19.

Table A.16 – Configuration via the VDL for FATDMA

Parameter	Number of bits	Description
Application identifier	16	Bits 15-6 = $1111011110_2 = 990_{10}$ Bits 5-0 = $001100_2 = 12_{10}$ Function identifier CBR structure – FATMDA
MMSI of AtoN	30	MMSI of AtoN
Channel	1	Select channel Ch 1 = 0 Ch 2 = 1
Enable/disable	1	Enable or disable slot reservation Enable = 1 Disable = 0
Message ID	6	This is an allowed message ID for AIS AtoN stations. When the message ID is 0 this indicates that the slots being defined will be used for chaining messages. These slots are not reserved on the VDL via a Message 20 until the competent authority requires their use and will reserve the slots at that time for the proper duration
Message ID index	3	To identify different versions of application-specific messages per message type – for example Message 8 may have more than one use. This index should start at 1.
FATDMA UTC hour	5	0-23; 24 = UTC hour not available = default; 25-31 not used
FATDMA UTC minute	6	0-59; 60 = UTC minute not available = default; 61-63 not used
FATDMA start slot	12	For all messages which need to be transmitted in FATDMA mode, starting slot ranging from 0 to 2249 should be used. A value of 4095 (FFF) discontinues broadcasts.
FATDMA slot interval	24	For all messages which need to be transmitted in FATDMA mode, slot interval ranging from 0 to $(24 \times 60 \times 2250)$.
Spare	16	Spare bits needed for 120-bit message content
AES encryption checksum	8	Required for AES algorithm
Total bits	128	

Table A.17 – Configuration via the VDL for RATDMA/CSTDMA

Parameter	Number of bits	Description
Application identifier	16	Bits 15-6 = $1111011110_2 = 990_{10}$ Bits 5-0 = $001101_2 = 13_{10}$ Function identifier for AAR – RATDMA/CSTDMA
MMSI of AtoN	30	MMSI of AtoN
Message ID	6	This is an allowed message ID for AIS AtoN Stations
Message ID index	3	To identify different versions of application specific messages per message ID – for instance Message 8 may have more than one use
RATDMA or CSTDMA	1	0 – RATDMA; 1 – CSTDMA
RATDMA/CSTDMA UTC hour for start slot channel 1	5	0-23; 24 UTC hour not available; 25-31 not used
RATDMA/CSTDMA UTC minute for channel 1	6	0-59; 60 UTC minute not available; 61-63 not used
RATDMA/CSTDMA UTC hour for start slot channel 2	5	0-23; 24 UTC hour not available; 25-31 not used
RATDMA/CSTDMA UTC minute for channel 2	6	0-59; 60 UTC minute not available; 61-63 not used
RATDMA/CSTDMA Time interval for channel 1	17	RATDMA/CSTDMA time interval ranges from 0 to $(24 \times 60 \times 60)$ s.
RATDMA/CSTDMA Time interval for channel 2	17	RATDMA/CSTDMA time interval ranges from 0 to $(24 \times 60 \times 60)$ s.
Spare	8	Spare bits needed for 120-bit message content
AES encryption checksum	8	Required for AES algorithm
Total bits	128	

Table A.18 – Query request via the VDL for AtoN broadcast rates

Parameter	Number of bits	Description
Application identifier	16	Bits 15-6 = $1111011110_2 = 990_{10}$ Bits 5-0 = $001110_2 = 14_{10}$ Function identifier for a query retrieving all message types and their broadcast schedule.
MMSI of AtoN	30	MMSI of AtoN
Channel selection	1	0 – indicates channel 1 1 – indicates channel 2 The query response will only be sent on a single channel
UTC hour for start slot	5	0-23; 24 = RATDMA/CSTDMA is used all other FATDMA fields ignored; 25-31 not used
UTC minute for start slot	6	0-59; 60 = UTC minute not available = default; 61-63 not used
Start slot	12	Starting slot for the query response
Spare	50	Spare bits needed for 120-bit message content
AES encryption checksum	8	Required for AES algorithm
Total bits	128	

Table A.19 – Query response via the VDL with AtoN broadcast rates

Parameter	Number of bits	Description
Application identifier	16	Bits 15-6 = $1111011110_2 = 990_{10}$ Bits 5-0 = $001111_2 = 15_{10}$ Function identifier response to query retrieving all message types and their broadcast schedule
MMSI of AtoN	30	MMSI of responding AtoN
Number of messages to report	6	Total number of messages being broadcast by this AtoN – if the total exceeds what will fit in the number of slots in the query, then it is the competent authority's responsibility to query again with the correct number of slot allocations.
Message ID	6	This is an allowed Message ID for AIS AtoN stations
Message identifier	3	To identify different versions of application specific messages per message ID – for example Message 8 may have more than one use.
Channel selection	1	0 – indicates channel 1 1 – indicates channel 2 The query response will only be sent on a single channel
FATDMA UTC hour	5	0-23; 24 RATDMA is used all other FATDMA fields ignored; 25-31 not used
FATDMA UTC minute	6	0-59; 60 UTC minute not available= default; 61-63 not used
FATDMA start slot	12	For all messages to be transmitted in FATDMA mode, starting slot ranging from 0 to 2249 should be used. A value of 4095 (FFF) indicates no broadcasts of the message.
FATDMA slot interval	24	For all messages to be transmitted in FATDMA mode, slot interval ranging from 0 to $(24 \times 60 \times 2250)$.
Enable/disable	1	Enable or disable slot reservation Enable = 1 Disable = 0
Spare	10	Spare bits needed for 120-bit message content
AES encryption checksum	8	Required for AES algorithm
Total bits	128	

A.5 Configuration of encryption key (CEK)

This structure assigns the encryption key that will be used by the AES algorithm to communicate configuration and status information via the VDL. The structure allows defining of 256 bits in 4 parts. This restriction is required in order to keep the VDL function to a single message. The initial encryption key, when shipped from the manufacturer, will be all zeros.

The parameters for configuration are given in Table A.20. Query for the encryption key is not allowed.

Table A.20 – Configuration via the VDL of encryption key

Parameter	Number of bits	Description
Application identifier	16	Bits 15-6 = $1111011110_2 = 990_{10}$ Bits 5-0 = $010000_2 = 16_{10}$ Function identifier setting the encryption key
MMSI of AtoN	30	MMSI of AtoN
Encryption key	64	64 bits of a new AES encryption key
Part of encryption key	2	Part 0...3 for 256 bits, 64 bits in each part
Spare	8	Spare bits needed for 120-bit message content
AES encryption checksum	8	Required for AES algorithm
Total bits	128	

A.6 Configure the receiver turn-on times (ARW)

This structure defines the operational period for the receivers. When chaining the duration of the receiver, wake-up time is required to be sufficient to allow correct operation of a chain.

The parameters are given in Tables A.21 to A.23.

Table A.21 – Configuration via the VDL for receiver turn-on times

Parameter	Number of bits	Description
Application identifier	16	Bits 15-6 = $1111011110_2 = 990_{10}$ Bits 5-0 = $010001_2 = 17_{10}$ Function identifier setting receiver power on
MMSI of AtoN	30	MMSI of AtoN
Receiver on or interval	1	0 = use interval setting as defined below; 1 = turn receiver on
Setup receiver wake-up time UTC hour	5	0-23; 24 = interval will be in minutes; 25-31 not used;
Setup receiver wake-up time UTC minute	6	0-59; 60 = indicates hourly activation (no minute increment); 61-63 not used
Setup receiver wake-up interval	8	Interval between receiver activation 1 min – 60 min if UTC hour is set to 24 1 h – 256 h if UTC hour is 0-23 (Note 168 h is once per week.)
Duration of setup receiver wake up time in UTC minutes	12	Maximum awake time Note 1440 min is 24 h 1441 to 4095 reserved for future use
Spare	42	Spare bits needed for 120-bit message content
AES encryption checksum	8	Required for AES algorithm
Total bits	128	

Table A.22 – Query request via the VDL for receiver turn-on times

Parameter	Number of bits	Description
Application identifier	16	Bits 15-6 = $1111011110_2 = 990_{10}$ Bits 5-0 = $010010_2 = 18_{10}$ Function identifier for ARW query
MMSI of AtoN	30	MMSI of AtoN
Channel selection	1	0 – indicates channel 1 1 – indicates channel 2 The query response will only be sent on a single channel
UTC hour for start slot	5	0-23; 24 = RATMDA is used, all other FATDMA fields ignored; 25-31 not used
UTC minute for start slot	6	0-59; 60 = UTC minute not available = default; 61-63 not used
Start slot	12	Starting slot for the query response
Spare	50	Spare bits needed for 120-bit message content
AES encryption checksum	8	Required for AES algorithm
Total bits	128	

Table A.23 – Query response via the VDL for receiver turn-on times

Parameter	Number of bits	Description
Application identifier	16	Bits 15-6 = $1111011110_2 = 990_{10}$ Bits 5-0 = $010011_2 = 19_{10}$ Function identifier answer to query for ARW The receiver turn on schedule
MMSI of AtoN	30	MMSI of responding AtoN
Receiver status	1	0 = using interval; 1 = on
Receiver turn on UTC hour	5	0-23; 24 = interval will be in minutes; 25-31 not used
Receiver turn on UTC minute	6	0-59; 60 = indicates hourly activation (no minute increment) 61-63 not used
Setup receiver wake-up interval	8	Interval between receiver activation 1 min – 60 min if UTC hour is set to 24 1 h – 256 h if UTC hour is 0-23 (Note 168 h is once per week.)
Duration of setup receiver wake up time in UTC minutes	12	Maximum awake time Note 1440 min is 24 h 1441 to 4095 reserved for future use
Spare	42	Spare bits needed for 120-bit message content
AES encryption checksum	8	Required for AES algorithm
Total bits	128	

A.7 Proprietary AtoN control command (MCR)

The payload of this structure will be proprietary information used to control the AtoN station.

The parameters are given in Tables A.24 to A.26.

Table A.24 – Configuration via the VDL for proprietary information

Parameter	Number of bits	Description
Application identifier	16	Bits 15-6 = $1111011110_2 = 990_{10}$ Bits 5-0 = $010100_2 = 20_{10}$ Function identifier AtoN control as defined by competent authority
MMSI of AtoN	30	MMSI of AtoN
Payload		As defined by competent authority
Spare		Spare bits needed for 120-bit message content
AES encryption checksum	8	Required for AES algorithm
Total bits	128	

Table A.25 – Query request via the VDL for proprietary information

Parameter	Number of bits	Description
Application identifier	16	Bits 15-6 = $1111011110_2 = 990_{10}$ Bits 5-0 = $010101_2 = 21_{10}$ Function identifier AtoN query control settings
MMSI of AtoN	30	MMSI of AtoN
Channel selection	1	0 – indicates channel 1 1 – indicates channel 2 The query response will only be sent on a single channel
UTC hour for start slot	5	0-23; 24 = RATMDA is used all other FATDMA fields ignored; 25-31 not used
UTC minute for start slot	6	0-59; 60 = UTC minute not available = default; 61-63 not used
Start slot	12	Starting slot for the query response
Spare	50	Spare bits needed for 120-bit message content
AES encryption checksum	8	Required for AES algorithm
Total bits	128	

Table A.26 – Query response via the VDL for proprietary information

Parameter	Number of bits	Description
Application identifier	16	Bits 15-6 = $1111011110_2 = 990_{10}$ Bits 5-0 = $010110_2 = 22_{10}$ Function identifier answer to query
MMSI of AtoN	30	MMSI of responding AtoN
Payload		As defined by manufacturer
Spare		Spare bits needed for 120-bit message content
AES encryption checksum	8	Required for AES algorithm
Total bits	128	

A.8 Configuration of message payload for broadcast (MEB)

This message will be used to command the AIS AtoN station to rebroadcast the payload or to define a new message for autonomous, continuous transmission. The CBR configuration with Message ID/Message ID index for a specific MEB should precede the MEB message to identify it as autonomous continuous transmission. If it is a single transmission, this payload will be broadcast using the slots reserved by the CBR message with Message ID/Message ID index = 0, or it will use the next available slot.

There is no VDL query for this message. Confirmation is done via reception of the broadcast message or the CBR may be queried to confirm that the message has been scheduled for autonomous transmission.

The parameters are given in Table A.27.

Table A.27 – Configuration or function via the VDL of message payload

Parameter	Number of bits	Description
Application identifier	16	Bits 15-6 = $1111011110_2 = 990_{10}$ Bits 5-0 = $010111_2 = 23_{10}$ Function identifier payload rebroadcast
MMSI of AtoN	30	MMSI of AtoN
Message ID	6	This is an allowed Message ID for AIS AtoN stations
Message ID index	3	To identify different versions of application specific messages per Message ID – for example Message 8 may have more than one use
Total number of structures	4	Total number of structures required to be received before a complete AIS message can be constructed; minimum of 3 is needed to broadcast a single slot message
Sequence number	4	Sequence number within the total number of structures required; should be sequential
Broadcast behaviour	1	0 = based upon AAR configuration 1 = use next available slot
Payload		The encapsulated data, as defined by IEC 61162-1, for a valid AIS AtoN station message.
Spare		Spare bits needed for 120-bit message content
AES encryption checksum	8	Required for AES algorithm
Total bits	128	

A.9 Forced broadcast command (AFB)

This structure is used to force a transmission of the indicated VDL message, this message is already known to the AIS AtoN station through CBR/MEB or ACF/ACG/CBR configuration commands.

The VDL function is used to force the broadcast of a message already defined by a CBR.

The parameters are given in Table A.28.

Table A.28 – Function via the VDL for forced broadcast

Parameter	Number of bits	Description
Application identifier	16	Bits 15-6 = $1111011110_2 = 990_{10}$ Bits 5-0 = $011000_2 = 24_{10}$ Function identifier forced broadcast
MMSI of AtoN	30	MMSI of AtoN
Message ID	6	This is an allowed message ID for AIS AtoN Stations
Message ID index	3	To identify different versions of application specific messages per message ID – for example Message 8 may have more than one use
Channel selection	1	0 – indicates channel 1 1 – indicates channel 2 The query response will only be sent on a single channel
UTC hour for start slot	5	0-23; 24 = RATMDA is used all other FATDMA fields ignored; 25-31 not used
UTC minute for start slot	6	0-59; 60 = UTC minute not available = default; 61-63 not used
Start slot	12	Starting slot for the query response; a value of 2251 indicates an RATDMA transmission
Spare	41	Spare bits needed for 120-bit message content
AES encryption checksum	8	Required for AES algorithm
Total bits	128	

A.10 Version information (VER)

This structure is used to provide identification and version information about a talker device. This structure is produced either as a reply to a query structure. The contents of the data fields, except for the unique identifier, should be manufactured into the talker device. The unique identifier is the AtoN station real MMSI. In order to meet the single slot requirement, a multi-structure message may be needed to convey all the data fields.

The parameters are given in Tables A.29 and A.30.

Table A.29 – Query request via the VDL for VER

Parameter	Number of bits	Description
Application identifier	16	Bits 15-6 = $1111011110_2 = 990_{10}$ Bits 5-0 = $011001_2 = 25_{10}$ Function identifier query for version information
MMSI of AtoN	30	MMSI of AtoN
Channel selection	1	0 – indicates channel 1 1 – indicates channel 2 The query response will only be sent on a single channel
UTC hour for start slot	5	0-23; 24 = RATMDA is used all other FATDMA fields ignored; 25-31 not used
UTC minute for start slot	6	0-59; 60 = UTC minute not available = default; 61-63 not used
Start slot	12	Starting slot for the query response
Kind of requested version information	4	0 = device type 1 = vendor ID 2 = unique identifier 3 = manufacturer serial number 4 = model code (product code) 5 = software revision 6 = hardware revision 7-15 = not used, for future use
Spare	46	Spare bits needed for 120-bit message content
AES encryption checksum	8	Required for AES algorithm
Total bits	128	

Table A.30 – Query response via the VDL for VER

Parameter	Number of bits	Description
Application identifier	16	Bits 15-6 = $1111011110_2 = 990_{10}$ Bits 5-0 = $011010_2 = 26_{10}$ Function identifier version information
MMSI of AtoN	30	MMSI of AtoN
Kind of requested version information	4	0 = device type 1 = vendor ID 2 = unique identifier 3 = manufacturer serial number 4 = model code (product code) 5 = software revision 6 = hardware revision 7-15 = not used, for future use
Requested version information	66	Version information as requested; manufacturer defined using 6-bit ASCII characters
Spare	4	Spare bits needed for 120-bit message content.
AES encryption checksum	8	Required for AES algorithm
Total bits	128	

A.11 AtoN function ID capability

This structure is used to provide the capability information of implemented function ID by the EUT.

The parameters are given in Tables A.31 and A.32.

Table A.31 – Query request via the VDL for function ID

Parameter	Number of bits	Description
Application identifier	16	Bits 15-6 = $1111011110_2 = 990_{10}$ Bits 5-0 = $011011_2 = 27_{10}$ Function identifier query for AtoN function ID capability
MMSI of AtoN	30	MMSI of AtoN
Channel selection	1	0 – indicates channel 1 1 – indicates channel 2 The query response will only be sent on a single channel
UTC hour for start slot	5	0-23; 24 = RATMDA is used all other FATDMA fields ignored; 25-31 not used
UTC minute for start slot	6	0-59; 60 = UTC minute not available = default; 61-63 not used
Start slot	12	Starting slot for the query response
Spare	50	Spare bits needed for 120-bit message content
AES encryption checksum	8	Required for AES algorithm
Total bits	128	

Table A.32 – Query response via the VDL for function ID

Parameter	Number of Bits	Description																		
Application identifier	16	Bits 15-6 = $1111011110_2 = 990_{10}$ Bits 5-0 = $011010_2 = 28_{10}$ Function identifier version information																		
MMSI of AtoN	30	MMSI of AtoN																		
Status of implementation for each function ID	64	Each bit corresponds to the function ID number and the bit value "0" indicates the function ID number is not supported and "1" indicates supported (see example below)																		
Spare	10	Spare bits needed for 120-bit message content																		
AES encryption checksum	8	Required for AES algorithm																		
Total bits	128																			
<p><Example></p> <table style="margin-left: 40px;"> <tr> <td>Bit</td> <td>0</td> <td>1</td> <td>2</td> <td>...</td> <td>63</td> </tr> <tr> <td></td> <td>(FI=0)</td> <td>(FI=1)</td> <td>(FI=2)</td> <td>...</td> <td>(FI=63)</td> </tr> <tr> <td>Value</td> <td>1</td> <td>0</td> <td>1</td> <td>...</td> <td>0</td> </tr> </table> <p>This example indicates that function ID = 0 and function ID = 2 are supported and function ID = 1 is not supported.</p>			Bit	0	1	2	...	63		(FI=0)	(FI=1)	(FI=2)	...	(FI=63)	Value	1	0	1	...	0
Bit	0	1	2	...	63															
	(FI=0)	(FI=1)	(FI=2)	...	(FI=63)															
Value	1	0	1	...	0															

A.12 Query via the VDL for Message 21 content

Function Identifier 33 messages are removed from this edition 2 of this standard because it is a two-slot message and therefore cannot be used with Message 25.

The response message is replaced by the Message 21 configuration response messages function identifier 39 to function identifier 42 (see Table A.3).

The definition of edition 1 of this standard was that if the AtoN station is not chained and within VDL range of the base station query via the VDL for ACE, and ACF verification is done using both a forced broadcast of Message 21 and additional functional queries.

Forced Message 21 provides the query information for the following settings:

- position accuracy;
- EPFS type;
- type of AtoN;
- dimensions;
- AtoN status bits;
- receiver and transmitter channels (query via the VDL does not work, unless at least one channel is known and functional);
- AtoN name;
- virtual AtoN flag.

If the AtoN station is chained and not within the VDL range of the base station the following queries shall be used to obtain:

- position accuracy;
- EPFS type;
- type of AtoN;

- dimensions;
- AtoN status bits;
- receiver and transmitter channels (query via the VDL does not work, unless at least one channel is known and functional);
- AtoN name;
- virtual AtoN flag.

The parameters from edition 1 of this standard are given in Tables A.33 and A.34.

Table A.33 – Query request via the VDL for Message 21 content

Parameter	Number of bits	Description
Application identifier	16	Bits 15-6 = $1111011110_2 = 990_{10}$ Bits 5-0 = $100000_2 = 32_{10}$ Function identifier for query for Message 21 content
MMSI of AtoN	30	MMSI of AtoN
Channel selection	1	0 – indicates channel 1 1 – indicates channel 2 The query response will only be sent on a single channel
UTC hour for start slot	5	0-23; 24 = RATMDA is used all other FATDMA fields ignored; 25-31 not used
UTC minute for start slot	6	0-59; 60 = UTC minute not available =default; 61-63 not used
Start slot	12	Starting slot for the query response
Spare	50	Spare bits needed for 120-bit message content
AES encryption checksum	8	Required for AES algorithm
Total bits	128	
NOTE Not used in this edition 2 of the standard.		

Table A.34 – Query response via the VDL for Message 21 content

Parameter	Number of bits	Description
Application identifier	16	Bits 15-6 = $1111011110_2 = 990_{10}$ Bits 5-0 = $100001_2 = 33_{10}$ Function identifier for answer to query for Message 21 content
Message 21 content	272-360	VDL Message 21 content as defined in Recommendation ITU-R M.1371
Spare		The number of spare bits should be adjusted in order to observe byte boundaries
NOTE Not used in this edition 2 of the standard.		

A.13 General query request

This message can be used as a general query request. It can replace the special request messages.

The parameters are given in Table A.35.

Table A.35 – General query request via the VDL

Parameter	Number of bits	Description
Application identifier	16	Bits 15-6 = $1111011110_2 = 990_{10}$ Bits 5-0 = $100010_2 = 34_{10}$ Function identifier general query
MMSI of AtoN	30	MMSI of AtoN
Channel selection	1	0 – indicates channel 1 1 – indicates channel 2 The query response will only be sent on a single channel
UTC hour for start slot	5	0-23; 24 = RATMDA is used all other FATDMA fields ignored; 25-31 not used
UTC minute for start slot	6	0-59; 60 = UTC minute not available = default; 61-63 not used
Start slot	12	Starting slot for the query response
Requested information	6	Function identifier of the requested message
Requested kind of information	4	Additional information for requested information, Query for FI26 (version): kind of requested version information Query for FI15 (broadcast rates); Message ID Index, 15 = all settings are requested
Message ID of requested information	6	Query for FI15 (broadcast rates): Message ID of requested setting, 0 = no information, all Message IDs are requested
Spare	34	Spare bits needed for 120-bit message content
AES encryption checksum	8	Required for AES algorithm
Total bits	128	

A.14 Configuration of receiver operational times command (COP)

This structure defines the operational period for the receivers. When chaining, the duration of the receiver wake-up time should be sufficient to allow correct operation of a chain.

The parameters are given in Table A.36.

The structure of the query response for receiver on time is identical to the configuration message except the function identifier is 36 instead of 35.

Table A.36 – Configuration via the VDL for COP

Parameter	Number of bits	Description
Application identifier	16	Bits 15-6 = $1111011110_2 = 990_{10}$ Bits 5-0 = $100011_2 = 35_{10}$ Function identifier setting receiver power on Bits 5-0 = $100100_2 = 36_{10}$ Function identifier receiver power on response
MMSI of AtoN	30	MMSI of AtoN
Operational Mode	2	0 = operation controlled by internal process using the defined operating schedule. 1 = enable operation 2 = disable operation 3 = reserved for future use
Start time UTC hour	5	0-23; 24-31 not used
Start time UTC minute	6	0-59;60-63 not used
Time interval between periods	14	Interval between receiver activation 1 – 10 080 min Time interval between periods = shall not be greater than 1 week (604800 s), shall not be higher resolution than 1 min, and the interval shall evenly divide an hour, day or be an integer number of days; this results in the following valid intervals: Minutes: 1,2,3,4,5,6,10,12,15,20,30 Hours: 1,2,3,4,6,8,12,24 Day: 1,2,3,4,5,6,7
Duration of period	11	1 to 1440 min 0 and 1441 to 2047 reserved for future use
Reference Year	14	1 to 9999 0 = year not available/ignore Years in the past are not permissible
Reference Month	4	1 to 12 0 = month not available/ignore 13 to 15 reserved for future use
Reference Day	5	1 to 31 0 = day not available/ignore
Spare	13	Spare bits needed for 120-bit message content
AES encryption checksum	8	Required for AES algorithm
Total bits	128	

A.15 Configuration of message payload for broadcast (MEB)

This message is used to define the control information and the message content for single or autonomous, continuous transmission. The broadcast rate configuration (FI 12,13) with Message ID/Message ID index for a specific message should precede the payload configuration to identify it as autonomous continuous transmission. If it is a single transmission, this payload will be broadcast using the slots reserved by FI 12,13 with Message ID/Message ID index = 0, or it will use the next available slot.

In a first step the payload control information message has to be applied, in a second step the payload has to be defined.

The parameters are given in Tables A.37 and A.38.

Table A.37 – Payload control configuration via the VDL

Parameter	Number of bits	Description
Application identifier	16	Bits 15-6 = $1111011110_2 = 990_{10}$ Bits 5-0 = $100101_2 = 37_{10}$ Function identifier payload control
MMSI of AtoN	30	MMSI of AtoN
Message ID	6	This is an allowed Message ID for AIS AtoN stations
Message ID index	3	To identify different versions of application specific messages per Message ID – for example Message 8 may have more than one use
Broadcast behaviour	1	0 = based upon CBR configuration 1 = use next available slot
Destination indicator	1	0 = broadcast 1 = addressed Required for message 25 and 26.
Binary data flag	1	0 = unstructured binary data 1 = binary data coded as defined by 16-bit application identifier
Destination MMSI	30	Required for addressed messages (destination indicator = 1)
Spare	32	Spare bits needed for 120-bit message content
AES encryption checksum	8	Required for AES algorithm
Total bits	128	

Table A.38 – Payload binary data via the VDL

Parameter	Number of bits	Description
Application identifier	16	Bits 15-6 = $1111011110_2 = 990_{10}$ Bits 5-0 = $100110_2 = 38_{10}$ Function identifier payload rebroadcast
MMSI of AtoN	30	MMSI of AtoN
Message ID	6	This is an allowed Message ID for AIS AtoN stations
Message ID index	3	To identify different versions of application-specific messages per Message ID – for example Message 8 may have more than one use
Total number of structures	4	Total number of structures required to be received before a complete AIS message can be constructed; minimum of 3 is needed to broadcast a single slot message
Sequence number	4	Sequence number within the total number of structures required; should be sequential
Payload length	6	Number of payload bits
Payload	8..48	Binary data or safety related text, for a valid AIS AtoN station message, including DAC/FI for structured binary data
Spare	3	Spare bits needed for 120-bit message content
AES encryption checksum	8	Required for AES algorithm
Total bits	128	

A.16 Query response via the VDL for Message 21 configuration

The following messages replace the Message 21 content response message, FI 33. Message FI 39 provides all Message 21 configuration information except the AtoN name. The other 3 messages (FI 40...42) provide the AtoN name. They are identical to the AtoN name configuration messages except the new function identifiers.

They can be queried using the general query, FI 34 (see A.13).

The parameters are given in Tables A.39 to A.42.

Table A.39 – Query response via the VDL, Message 21 configuration

Parameter	Number of bits	Description
Application identifier	16	Bits 15-6 = $1111011110_2 = 990_{10}$ Bits 5-0 = $100111_2 = 39_{10}$ Function identifier for Message 21 content
MMSI of AtoN	30	MMSI of AtoN
Type of AtoN	5	0 = not available = default; refer to appropriate definition set up in ITU-R M.1371
Dimensions	30	Reference point for reported position; also indicates the dimension of aids-to-navigation (see ITU-R M.1371) Should be given as aaabbbccdd
AtoN status bits	8	Indication of the AtoN status, default "00000000 ₂ "
Virtual AtoN flag	2	0 = real 1 = virtual AtoN 2 = synthetic AtoN (flag remains 0 in Message 21 but the repeat indicator should be > 0)
Position accuracy	1	1 = high; 0 = low = default
EPFS type	4	As defined in ITU-R M.1371
Acknowledgement procedure	1	Determines behaviour for message acknowledgement 0 = will provide acknowledgement as defined by manufacturer 1 = will not provide acknowledgement
Spare	23	Spare bits needed for 120-bit message content
AES encryption checksum	8	Required for AES algorithm
Total bits	128	

Table A.40 – Query response via the VDL, first 12 characters of AtoN name

Parameter	Number of bits	Description
Application identifier	16	Bits 15-6 = $1111011110_2 = 990_{10}$ Bits 5-0 = $101000_2 = 40_{10}$ Function identifier for Message 21 content First 12 characters of AtoN name
MMSI of AtoN	30	MMSI of AtoN
Name of AtoN	72	First 12 characters of 34 characters for name of AtoN
Spare	2	Spare bits needed for 120-bit message content
AES encryption checksum	8	Required for AES algorithm
Total bits	128	

Table A.41 – Query response via the VDL, second 12 characters of AtoN name

Parameter	Number of bits	Description
Application identifier	16	Bits 15-6 = $1111011110_2 = 990_{10}$ Bits 5-0 = $101001_2 = 41_{10}$ Function identifier for Message 21 content Second 12 characters of AtoN name
MMSI of AtoN	30	MMSI of AtoN
Name of AtoN	72	Second 12 characters of 34 characters for name of AtoN
Spare	2	Spare bits needed for 120-bit message content
AES encryption checksum	8	Required for AES algorithm
Total bits	128	

Table A.42 – Query response via the VDL, last 10 characters of AtoN name

Parameter	Number of bits	Description
Application identifier	16	Bits 15-6 = $1111011110_2 = 990_{10}$ Bits 5-0 = $101010_2 = 42_{10}$ Function identifier for Message 21 content Last 10 characters of AtoN name
MMSI of AtoN	30	MMSI of AtoN
Name of AtoN	60	Last 10 characters of 34 characters for name of AtoN
Spare	14	Spare bits needed for 120-bit message content
AES encryption checksum	8	Required for AES algorithm
Total bits	128	

Annex B
(normative)

Message 21 – AtoN status bits

Initial factory default setting for the AtoN status bits of Message 21 shall be all zeros. These 8 bits may also represent the AtoN status as defined by IALA recommendation A-126.

IALA A-126 defines the first three bits as a page ID. The page ID can range from 0 to 7, allowing 8 pages. The first page (Page ID 0 (000)) is defined as the default “not used” condition in Recommendation ITU-R M.1371. Page IDs 1 to 3 are being used regionally and Page IDs 4 to 6 are not defined and are reserved for future use. Page ID 7 is used for the general AtoN status as shown in Figure B.1.

Table B.1 contains an overview of all IALA A-126 defined AtoN status pages.

Table B.1 – AtoN status pages

Page ID	Name	Use
0 (000)	Default	AtoN status bits are not used
1 (001)	Regional page	Reserved for future use
2 (010)	Regional page	Reserved for future use
3 (011)	Regional page	Reserved for future use
4 (100)	International page	Reserved for future use
5 (101)	International page	Reserved for future use
6 (110)	International page	Reserved for future use
7 (111)	General AtoN Status	RACON, light status, & health

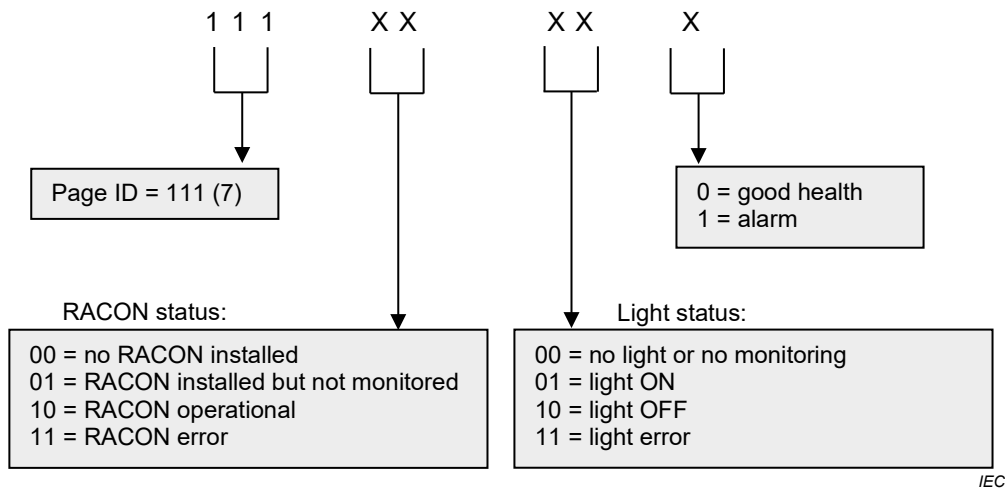

Figure B.1 – Use of AtoN status bits as IALA A-126 Page ID 7

For further details on the use of the AtoN status pages refer to IALA documentation.

Bibliography

IEC 60950, *Information technology equipment – Safety*

IEC 61162-1, *Maritime navigation and radiocommunication equipment and systems – Digital interfaces – Part 1: Single talker and multiple listeners*

IEC 61162-2, *Maritime navigation and radiocommunication equipment and systems – Digital interfaces – Part 2: Single talker and multiple listeners, high-speed transmission*

IEC 61162-460, *Maritime navigation and radiocommunication equipment and systems – Digital interfaces – Part 460: Multiple talkers and multiple listeners – Ethernet interconnection – Safety and Security*

IEC 61993-2, *Maritime navigation and radiocommunication equipment and systems – Automatic identification systems (AIS) – Part 2: Class A shipborne equipment of the universal automatic identification system (AIS) – Operational and performance requirements, methods of test and required test results*

ISO/IEC 10118-3, *Information technology – Security techniques – Hash-functions – Part 3: Dedicated hash-functions*

ISO/IEC 13239:2002, *Information technology – Telecommunications and information exchange between systems – High-level data link control (HDLC) procedures*

ISO/IEC 18033-3, *Information Technology – Security Techniques – Encryption algorithms – Part 3: Block ciphers*

IMO MSC.1/Circ.1473, *Policy on use of AIS Aids to Navigation*

ITU-R Recommendation M.585, *Assignment and use of identities in the maritime mobile service*

ITU-R Recommendation M.1084, *Interim solutions for improved efficiency in the use of the band 156-174 MHz by stations in the maritime mobile service*

ITU-T Recommendation O.153, *Basic parameters for the measurement of error performance at bit rates below the primary rate*

NMEA 0183:June 2012, *Standard for Interfacing Marine Electronic Devices, Version 4.10*

British Standards Institution (BSI)

BSI is the national body responsible for preparing British Standards and other standards-related publications, information and services.

BSI is incorporated by Royal Charter. British Standards and other standardization products are published by BSI Standards Limited.

About us

We bring together business, industry, government, consumers, innovators and others to shape their combined experience and expertise into standards-based solutions.

The knowledge embodied in our standards has been carefully assembled in a dependable format and refined through our open consultation process. Organizations of all sizes and across all sectors choose standards to help them achieve their goals.

Information on standards

We can provide you with the knowledge that your organization needs to succeed. Find out more about British Standards by visiting our website at bsigroup.com/standards or contacting our Customer Services team or Knowledge Centre.

Buying standards

You can buy and download PDF versions of BSI publications, including British and adopted European and international standards, through our website at bsigroup.com/shop, where hard copies can also be purchased.

If you need international and foreign standards from other Standards Development Organizations, hard copies can be ordered from our Customer Services team.

Copyright in BSI publications

All the content in BSI publications, including British Standards, is the property of and copyrighted by BSI or some person or entity that owns copyright in the information used (such as the international standardization bodies) and has formally licensed such information to BSI for commercial publication and use.

Save for the provisions below, you may not transfer, share or disseminate any portion of the standard to any other person. You may not adapt, distribute, commercially exploit, or publicly display the standard or any portion thereof in any manner whatsoever without BSI's prior written consent.

Storing and using standards

Standards purchased in soft copy format:

- A British Standard purchased in soft copy format is licensed to a sole named user for personal or internal company use only.
- The standard may be stored on more than 1 device provided that it is accessible by the sole named user only and that only 1 copy is accessed at any one time.
- A single paper copy may be printed for personal or internal company use only.

Standards purchased in hard copy format:

- A British Standard purchased in hard copy format is for personal or internal company use only.
- It may not be further reproduced – in any format – to create an additional copy. This includes scanning of the document.

If you need more than 1 copy of the document, or if you wish to share the document on an internal network, you can save money by choosing a subscription product (see 'Subscriptions').

Reproducing extracts

For permission to reproduce content from BSI publications contact the BSI Copyright & Licensing team.

Subscriptions

Our range of subscription services are designed to make using standards easier for you. For further information on our subscription products go to bsigroup.com/subscriptions.

With **British Standards Online (BSOL)** you'll have instant access to over 55,000 British and adopted European and international standards from your desktop. It's available 24/7 and is refreshed daily so you'll always be up to date.

You can keep in touch with standards developments and receive substantial discounts on the purchase price of standards, both in single copy and subscription format, by becoming a **BSI Subscribing Member**.

PLUS is an updating service exclusive to BSI Subscribing Members. You will automatically receive the latest hard copy of your standards when they're revised or replaced.

To find out more about becoming a BSI Subscribing Member and the benefits of membership, please visit bsigroup.com/shop.

With a **Multi-User Network Licence (MUNL)** you are able to host standards publications on your intranet. Licences can cover as few or as many users as you wish. With updates supplied as soon as they're available, you can be sure your documentation is current. For further information, email subscriptions@bsigroup.com.

Revisions

Our British Standards and other publications are updated by amendment or revision.

We continually improve the quality of our products and services to benefit your business. If you find an inaccuracy or ambiguity within a British Standard or other BSI publication please inform the Knowledge Centre.

Useful Contacts

Customer Services

Tel: +44 345 086 9001

Email (orders): orders@bsigroup.com

Email (enquiries): cservices@bsigroup.com

Subscriptions

Tel: +44 345 086 9001

Email: subscriptions@bsigroup.com

Knowledge Centre

Tel: +44 20 8996 7004

Email: knowledgecentre@bsigroup.com

Copyright & Licensing

Tel: +44 20 8996 7070

Email: copyright@bsigroup.com

BSI Group Headquarters

389 Chiswick High Road London W4 4AL UK