



BSI Standards Publication

Maritime navigation and radiocommunication equipment and systems — Automatic identification system (AIS)

Part 1: AIS Base Stations — Minimum operational and performance requirements, methods of testing and required test results

National foreword

This British Standard is the UK implementation of EN 62320-1:2015. It is identical to IEC 62320-1:2015. It supersedes BS EN 62320-1:2007+A1:2009 which will be withdrawn on 24 February 2018.

The UK participation in its preparation was entrusted to Technical Committee EPL/80, Maritime navigation and radiocommunication equipment and systems.

A list of organizations represented on this committee can be obtained on request to its secretary.

This publication does not purport to include all the necessary provisions of a contract. Users are responsible for its correct application.

© The British Standards Institution 2015.

Published by BSI Standards Limited 2015

ISBN 978 0 580 86734 7

ICS 47.020.70

Compliance with a British Standard cannot confer immunity from legal obligations.

This British Standard was published under the authority of the Standards Policy and Strategy Committee on 31 March 2015.

Amendments/corrigenda issued since publication

Date	Text affected
-------------	----------------------

English Version

Maritime navigation and radiocommunication equipment and systems - Automatic identification system (AIS) - Part 1: AIS Base Stations - Minimum operational and performance requirements, methods of testing and required test results (IEC 62320-1:2015)

Equipements et systèmes de navigation et de radiocommunication maritimes - Systèmes d'identification automatique (AIS) - Partie 1: Stations de base AIS - Exigences minimales opérationnelles et de performance, méthodes de mesure et résultats de test minimum attendus (IEC 62320-1:2015)

Navigations- und Funkkommunikationsgeräte und -systeme für die Seeschifffahrt - Automatische Identifikationssysteme (AIS) - Teil 1: AIS-Basisstationen - Mindest-Betriebs- und Leistungsanforderungen, Prüfverfahren und geforderte Prüfergebnisse (IEC 62320-1:2015)

This European Standard was approved by CENELEC on 2015-02-24. CENELEC members are bound to comply with the CEN/CENELEC Internal Regulations which stipulate the conditions for giving this European Standard the status of a national standard without any alteration.

Up-to-date lists and bibliographical references concerning such national standards may be obtained on application to the CEN-CENELEC Management Centre or to any CENELEC member.

This European Standard exists in three official versions (English, French, German). A version in any other language made by translation under the responsibility of a CENELEC member into its own language and notified to the CEN-CENELEC Management Centre has the same status as the official versions.

CENELEC members are the national electrotechnical committees of Austria, Belgium, Bulgaria, Croatia, Cyprus, the Czech Republic, Denmark, Estonia, Finland, Former Yugoslav Republic of Macedonia, France, Germany, Greece, Hungary, Iceland, Ireland, Italy, Latvia, Lithuania, Luxembourg, Malta, the Netherlands, Norway, Poland, Portugal, Romania, Slovakia, Slovenia, Spain, Sweden, Switzerland, Turkey and the United Kingdom.



European Committee for Electrotechnical Standardization
Comité Européen de Normalisation Electrotechnique
Europäisches Komitee für Elektrotechnische Normung

CEN-CENELEC Management Centre: Avenue Marnix 17, B-1000 Brussels

Foreword

The text of document 80/736/CDV, future edition 2 of IEC 62320-1, prepared by IEC/TC 80 "Maritime navigation and radiocommunication equipment and systems" was submitted to the IEC-CENELEC parallel vote and approved by CENELEC as EN 62320-1:2015.

The following dates are fixed:

- latest date by which the document has to be implemented at national level by publication of an identical national standard or by endorsement (dop) 2015-11-24
- latest date by which the national standards conflicting with the document have to be withdrawn (dow) 2018-02-24

This document supersedes EN 62320-1:2007.

Attention is drawn to the possibility that some of the elements of this document may be the subject of patent rights. CENELEC [and/or CEN] shall not be held responsible for identifying any or all such patent rights.

Endorsement notice

The text of the International Standard IEC 62320-1:2015 was approved by CENELEC as a European Standard without any modification.

Annex ZA (normative)

Normative references to international publications with their corresponding European publications

The following documents, in whole or in part, are normatively referenced in this document and are indispensable for its application. For dated references, only the edition cited applies. For undated references, the latest edition of the referenced document (including any amendments) applies.

NOTE 1 When an International Publication has been modified by common modifications, indicated by (mod), the relevant EN/HD applies.

NOTE 2 Up-to-date information on the latest versions of the European Standards listed in this annex is available here: www.cenelec.eu.

<u>Publication</u>	<u>Year</u>	<u>Title</u>	<u>EN/HD</u>	<u>Year</u>
IEC 61108-1	-	Maritime navigation radiocommunication equipment and systems - Global navigation satellite systems (GNSS) -- Part 1: Global positioning system (GPS) - Receiver equipment - Performance standards, methods of testing and required test results	andEN 61108-1	-
IEC 61162-1	2010	Maritime navigation radiocommunication equipment and systems - Digital interfaces -- Part 1: Single talker and multiple listeners	andEN 61162-1	2011
IEC 61993-2	-	Maritime navigation radiocommunication equipment and systems - Automatic Identification Systems (AIS) -- Part 2: Class A shipborne equipment of the automatic identification system (AIS) - Operational and performance requirements, methods of test and required test results	andEN 61993-2	-
IEC 62287-1	2010	Maritime navigation radiocommunication equipment and systems - Class B shipborne equipment of the automatic identification system (AIS) -- Part 1: Carrier-sense time division multiple access (CSTDMA) techniques	andEN 62287-1	2011
IEC 62320-2	-	Maritime navigation radiocommunication equipment and systems - Automatic identification system (AIS) -- Part 2: AIS AtoN stations - Operational and performance requirements, methods of testing and required test results	andEN 62320-2	-
IALA Recommendation A-124	-	On Automatic Identification System (AIS)-Shore Station networking aspects relating to the AIS Service		-
IMO Resolution- MSC.74(69)	-	Performance standards for an Universal-shipborne automatic identification systems (AIS)		-
ITU-R Recommendation M.1084-4	-	Interim solutions for improved efficiency in the use of the band 156-174 MHz by stations in the maritime mobile service		-

ITU-R Recommendation M.1371-1	-	Technical characteristics for a universal- shipborne automatic identification system using time division multiple access in the VHF maritime mobile band	-
RTCM version 2.4	10402-	RTCM Recommended Standards for- Differential GNSS (Global Navigation Satellite Systems) Service	-

CONTENTS

INTRODUCTION.....	9
1 Scope.....	10
2 Normative references	10
3 Abbreviations	11
4 Functional layout of an AIS Base Station	12
4.1 General.....	12
4.2 Functional block diagram of an AIS Base Station	12
4.3 General VDL requirements.....	13
4.3.1 Sources of VDL messages for transmission	13
4.3.2 Use of access schemes	14
4.4 Functional diagram for operation of a Base Station	14
4.5 Base Station input/output sentence formatters	15
5 Functional definition of the radio interface of the AIS Base Station	17
5.1 General requirements of the physical layer	17
5.2 Required parameter settings for the physical layer of the AIS Base Station.....	18
5.3 Minimum requirements for the TDMA transmitter of the AIS Base Station	19
5.4 Minimum requirements for the TDMA receivers of the AIS Base Station	21
5.5 Shutdown procedure for an AIS Base Station.....	21
6 Requirements for AIS Base Station.....	21
6.1 General.....	21
6.2 Dependent Base Station requirements	22
6.2.1 General rules.....	22
6.2.2 General processing diagram	22
6.2.3 AIS Base Station response to PI input	23
6.2.4 AIS Base Station response to VDL input.....	23
6.3 Independent Base Station requirements.....	23
6.3.1 General rules.....	23
6.3.2 General processing diagram	24
6.3.3 AIS Base Station response to PI input	24
6.3.4 AIS Base Station interaction on the VDL.....	25
6.3.5 Autonomous channel management	29
6.4 BIIT conditions.....	30
6.5 Default settings after reset.....	30
6.6 Further requirements for optional features	31
6.6.1 General	31
6.6.2 External synchronisation source option.....	31
6.6.3 DGNSS dedicated port option.....	32
7 Functional definition of the presentation interface of the AIS Base Station	32
7.1 Physical requirements for the presentation interface	32
7.2 Presentation interface data exchange	32
7.2.1 General	32
7.2.2 Base Station presentation interface output.....	32
7.2.3 Base Station presentation interface input.....	32
7.2.4 TAG blocks on presentation interface	32

8	Tests of AIS Base Stations – Method of measurement and required results	33
8.1	General.....	33
8.2	Test conditions	33
8.2.1	Normal test conditions	33
8.2.2	Extreme test conditions	33
8.2.3	Standard test environment.....	33
8.2.4	Test signals	34
8.2.5	Arrangements for test signals applied to the receiver input	35
8.2.6	Encoder for receiver measurements	35
8.2.7	Waiver for receivers.....	35
8.2.8	Impedance.....	35
8.2.9	Artificial antenna (dummy load)	35
8.2.10	Facilities for access	35
8.2.11	Operation of the transmitter	35
8.2.12	Measurement uncertainties	36
9	Physical radio tests	36
9.1	Remark.....	36
9.2	General transceiver tests	36
9.2.1	Transceiver protection test	36
9.2.2	Transmitter shutdown procedure.....	37
9.3	TDMA transmitter.....	37
9.3.1	General	37
9.3.2	Frequency error.....	37
9.3.3	Carrier power.....	38
9.3.4	Modulation spectrum slotted transmission.....	38
9.3.5	Transmitter test sequence and modulation accuracy verification	39
9.3.6	Transmitter output power versus time function	40
9.3.7	Intermodulation attenuation	40
9.4	TDMA receivers	42
9.4.1	Sensitivity.....	42
9.4.2	Error behaviour at high input levels.....	42
9.4.3	Co-channel rejection.....	43
9.4.4	Adjacent channel selectivity.....	44
9.4.5	Spurious response rejection	44
9.4.6	Intermodulation response rejection	47
9.4.7	Blocking or desensitisation	48
9.5	Conducted spurious emissions at the antenna	49
9.5.1	Spurious emissions from the receiver	49
9.5.2	Spurious emissions from the transmitter	49
10	Functional tests for Base Station	49
10.1	Pre-set-up.....	49
10.1.1	Basic initialisation.....	49
10.1.2	Pre-setup of dependent base station	50
10.1.3	Pre-setup for independent mode.....	50
10.2	Normal operation	51
10.2.1	Base Station configuration and services	51
10.2.2	Addressed and broadcast messaging	66
10.2.3	Interrogations and interrogation response.....	69
10.2.4	Addressed operation.....	70

10.2.5	Slot phase and frame synchronisation – Base Station operation	71
10.2.6	Position source	75
10.2.7	Alarm messages	76
10.3	Selection of transmission slots	77
10.3.1	RATDMA Transmission	77
10.3.2	Intentional slot reuse (link congestion)	77
10.4	Legacy support	78
10.4.1	Purpose	78
10.4.2	Method of measurement	78
10.4.3	Required results	79
10.5	TAG Block encapsulation	79
10.5.1	Application	79
10.5.2	TAG Block capabilities	80
10.5.3	Activation of Source identification for output	80
10.5.4	Activation of Destination identification	81
10.5.5	Activation of Source identification for input	82
10.5.6	Use of multiple Source identifications for input	82
10.5.7	Test of grouping by TAG blocks for output	83
10.5.8	Test of UNIX time output	85
10.5.9	Test of Line-count output	85
10.6	Test of optional functions	86
10.6.1	Test of external synchronization source	86
10.6.2	Test of Message 17 based on RTCM 10402 input	87
Annex A (normative) AIS Base Station sentences		88
A.1	General	88
A.2	ACM – AIS Base Station addressed channel management command	88
A.3	ADS – Automatic device status	89
A.4	AGA – AIS Base Station broadcast of a group assignment command	90
A.5	ASN – AIS Base Station broadcast of assignment command	92
A.6	BCG – Base Station configuration, general command	93
A.7	BCL – Base Station configuration, location command	94
A.8	DLM – Data link management slot allocations for Base Station command	95
A.9	ECB – Configure broadcast schedules for Base Station messages, command	97
A.10	FSR – Frame summary of AIS reception	98
A.11	RST – Equipment Reset Command	99
A.12	SID – Set an equipment's identification and command	100
A.13	SPO – Select AIS device's processing and output command	101
A.14	TFR – Transmit feed-back report	102
A.15	TPC – Transmit slot prohibit command	103
A.16	TSA – Transmit slot assignment	104
A.17	TSR – Transmit slot prohibit status report	105
A.18	VSI – VDL signal information	106
Annex B (normative) Legacy AIS Base Station sentences		107
B.1	Legacy sentences	107
B.1.1	BCE – Extended general Base Station configuration	107
B.1.2	BCF – General Base Station configuration	107
B.1.3	CAB – Control AIS Base Station	109
B.1.4	TSP – Transmit slot prohibit	109
B.2	Comment block	110

B.3	Comment block parameters for AIS.....	111
B.3.1	General	111
B.3.2	Comment block parameter format	111
B.3.3	Comment block “hexadecimal checksum” (*hh).....	111
B.3.4	Line (either a comment block, or comment block and sentence)	111
B.3.5	Group (associated lines).....	112
B.3.6	Parameter-code dictionary.....	112
B.3.7	Line linking (sentence linking).....	112
B.3.8	Comment block used with query sentences.....	113
Annex C	(normative) IEC 61162-1 sentences modified for use with AIS Base Station	115
C.1	General.....	115
C.2	CBR – Configure broadcast rates for AIS AtoN Station message command.....	115
C.3	MEB – Message Input for broadcast command.....	116
C.4	NAK – Negative acknowledgement.....	118
Annex D	(normative) AIS Base Station TAG block sentences	120
D.1	General.....	120
D.2	CPC – Configure parameter-code for UNIX time parameter (c)	120
D.3	CPD – Configure parameter-code for Destination identification parameter (d).....	121
D.4	CPG – Configure parameter-code for the sentence-grouping parameter (g)	121
D.5	CPN – Configure parameter-code for the line-count parameter (n)	123
D.6	CPS – Configure parameter-code for the Source identification parameter(s)	125
D.7	TBR – TAG block report request	125
D.8	TBS – TAG block listener Source identification configuration command	126
Bibliography	128
Figure 1	– Functional block diagram of an AIS Base Station	13
Figure 2	– Functional block diagram dependent and independent operation.....	15
Figure 3	– Modulation spectrum for slotted transmission.....	20
Figure 4	– Power versus time mask	20
Figure 5	– General processing diagram.....	23
Figure 6	– General processing diagram.....	24
Figure 7	– Flow diagram for AIS Base Station response to VDM input.....	28
Figure 8	– Format for repeating four-packet cluster.....	34
Figure 9	– Measurement arrangement for frequency error.....	37
Figure 10	– Measurement arrangement for carrier power	38
Figure 11	– Measurement arrangement for modulation accuracy.....	39
Figure 12	– Measurement arrangement for intermodulation attenuation	41
Figure 13	– Measurement arrangement for sensitivity	42
Figure 14	– Measurement arrangement for error behaviour.....	42
Figure 15	– Measurement arrangement for co-channel rejection	43
Figure 16	– Measurement arrangement for adjacent channel selectivity.....	44
Figure 17	– PER/BER or SINAD measuring equipment	45
Figure 18	– Measurement arrangement for inter-modulation	47
Figure 19	– Measurement arrangement for blocking or de-sensitisation	48
Figure A.1	– Frame summary timing	98

Table 1 – Base Station input/output sentence formatters	16
Table 2 – Required parameter settings for an AIS Base Station	18
Table 3 – Required settings of physical layer constants	18
Table 4 – Bandwidth related parameters of the physical layer of the AIS Base Station	18
Table 5 – Minimum required TDMA transmitter characteristics	19
Table 6 – Definition of timings for Figure 4	20
Table 7 – Minimum TDMA receiver characteristics	21
Table 8 – Base Station response to input messages from the VDL	23
Table 9 – Base Station response to input messages from the VDL	25
Table 10 – Required content of FSR and VSI output	26
Table 11 – Base Station response to ABM, BBM and AIR input on the PI	27
Table 12 – BIIT alarm conditions monitored by an AIS Base Station	30
Table 13 – Settings after reset command	30
Table 14 – Required TAG block functions	32
Table 15 – Content of first two packets	34
Table 16 – Fixed PRS data derived from ITU-T O.153	35
Table 17 – Maximum values of absolute measurement uncertainties	36
Table 18 – Frequencies for inter-modulation tests	48
Table 19 – Calculation of parameters in Message 16	63

INTRODUCTION

Chapter V of the International Convention for the Safety of Life at Sea 1974 (SOLAS) requires mandatory carriage of Automatic Identification System (AIS) equipment on all vessels constructed on or after 01 July 2002. Carriage for other types and sizes of SOLAS Convention vessels was required to be completed not later than 31 December 2004.

SOLAS Chapter V, Regulation 19, states that AIS shall:

- a) provide automatically to appropriate equipped shore stations, other ships and aircraft information, including ship's identity, type, position, course, speed, navigational status and other safety-related information;
- b) receive automatically such information from similarly fitted ships;
- c) monitor and track ships; and
- d) exchange data with shore-based facilities.

In addition, the IMO performance standards for AIS state that:

- The AIS should improve the safety of navigation by assisting in the efficient navigation of ships, protection of the environment, and operation of Vessel Traffic Services (VTS), by satisfying the following functional requirements:
 - 1) in a ship-to-ship mode for collision avoidance;
 - 2) as a means for littoral States to obtain information about a ship and its cargo; and
 - 3) as a VTS tool, i.e. ship-to-shore (traffic management).
- The AIS should be capable of providing to ships and to competent authorities, information from the ship, automatically and with the required accuracy and frequency, to facilitate accurate tracking. Transmission of the data should be with the minimum involvement of ship's personnel and with a high level of availability.

The provision of Shore Based AIS is necessary to attain the full benefit of the SOLAS Convention requirements.

This part of IEC 62320 provides the minimum operational and performance requirements, methods of test and the required test results for AIS Base Stations. The testing is divided into three sections, the transceiver tests, the logical tests and the Presentation Interface tests. These are captured in Clauses 8, 9 and 10 respectively. The method used for testing is that the EUT should meet all the tests requirements of Clause 8 before proceeding to Clause 9. Likewise, the unit should meet all of the test requirements before proceeding to Clause 10. Clause 10 has also been prioritised so that the tests are progressive.

Clauses 5 to 7 provide functional requirement information and Clause 8 provides the general test environment for the EUT.

MARITIME NAVIGATION AND RADIOCOMMUNICATION EQUIPMENT AND SYSTEMS – AUTOMATIC IDENTIFICATION SYSTEM (AIS) –

Part 1: AIS Base Stations – Minimum operational and performance requirements, methods of testing and required test results

1 Scope

This part of IEC 62320 specifies the minimum operational and performance requirements, methods of testing and required test results for AIS Base Stations, compatible with the performance standards adopted by IMO Resolution MSC.74 (69), Annex 3, Universal AIS. It incorporates the technical characteristics of non-shipborne, fixed station AIS equipment, included in recommendation ITU-R M.1371 and IALA Recommendation A-124. Where applicable, it also takes into account the ITU Radio Regulations. This standard takes into account other associated IEC international standards and existing national standards, as applicable.

This standard is applicable for AIS Base Stations. It does not include specifications for the display of AIS data on shore.

2 Normative references

The following documents, in whole or in part, are normatively referenced in this document and are indispensable for its application. For dated references, only the edition cited applies. For undated references, the latest edition of the referenced document (including any amendments) applies.

IEC 61108-1, *Maritime navigation and radiocommunication equipment and systems – Global navigation satellite systems (GNSS) – Part 1: Global positioning system (GPS) – Receiver equipment – Performance standards, methods of testing and required test results*

IEC 61162-1:2010, *Maritime navigation and radiocommunication equipment and systems – Digital interfaces – Part 1: Single talker and multiple listeners*

IEC 61993-2, *Maritime navigation and radiocommunication equipment and systems – Automatic identification systems (AIS) – Part 2: Class A shipborne equipment of the automatic identification system (AIS) – Operational and performance requirements, methods of test and required test results*

IEC 62287-1:2010, *Maritime navigation and radiocommunication equipment and systems – Class B shipborne equipment of the automatic identification system (AIS) – Part 1: Carrier-sense time division multiple access (CSTDMA) techniques*
IEC 62287-1:2010/AMD1:2013

IEC 62320-2, *Maritime navigation and radiocommunication equipment and systems – Automatic identification system (AIS) – Part 2: AIS AtoN Stations – Operational and performance requirements, methods of testing and required test results*

IMO Resolution MSC.74 (69), Annex 3, *Recommendation on performance standards for an universal shipborne automatic identification system (AIS)*

ITU-R Recommendation M.1084-4, *Interim solutions for improved efficiency in the use of the band 156-174 MHz by stations in the maritime mobile service*

ITU-R Recommendation M.1371, *Technical characteristics for an automatic identification system using time division multiple access in the VHF maritime mobile band*

RTCM 10402 – *RTCM Recommended Standards for Differential GNSS (Global Navigation Satellite Systems) Service*

IALA Recommendation A-124 *on Automatic Identification System (AIS). Shore Station and networking aspects relating to the AIS Service*

3 Abbreviations

AIS	Automatic Identification System
AtoN	Aids to Navigation
BER	Bit Error Rate
BIIT	Built-In Integrity Tests
BT	Bandwidth Time product
CommState	Communication State

NOTE Communication state is defined in Recommendation ITU-R M.1371-4. It is used to indicate whether the AIS is using the message structure for SOTDMA or ITDMA.

DGNSS	Differential Global Navigation Satellite System
EPFS	Electronic position fixing system
EUT	Equipment under test
FATDMA	Fixed Access Time Division Multiple Access
GNSS	Global Navigation Satellite System
IALA	International Association of Marine Aids to Navigation and Lighthouse Authorities
IMO	International Maritime Organization
ITU	International Telecommunication Union
LFR	Limited Frequency Range
MAC	Medium Access Control
MMSI	Maritime Mobile Service Identity
NM	Nautical Mile
NRZI	Non-Return to Zero Inverted
PER	Packet Error Rate
P _c	Carrier Power
PI	Presentation Interface
PPS	Pulse Per Second
PSS	Physical Shore Station
RAIM	Receiver Autonomous Integrity Monitoring
RATDMA	Random Access Time Division Multiple Access
RSSI	Received signal strength indicator
Rx	Receive
SFI	Specific Frequency of Interest

TDMA	Time Division Multiple Access
Tx	Transmit
UI	Unique Identifier
UTC	Universal Time Co-ordinated
VDL	VHF Data Link
VSWR	Voltage Standing Wave Ratio
VTs	Vessel Traffic Services

4 Functional layout of an AIS Base Station

4.1 General

The Base Station may be designed for dependent only operation or independent operation. Both are under some control of the Physical Shore Station (PSS) as defined in the IALA Recommendation A-124.

- dependent Base Station accesses the VHF data link (VDL) using only the combination of linked TSA+VDM sentences (see Table 1), as provided by the PSS.
- An independent Base Station accesses the VDL using either the combination of linked TSA+VDM sentences as provided by the PSS or by using internal control. When operated as an independent Base Station the unit may be delegated certain autonomous functionality under the supervisory control of the PSS.

The PSS, or external controlling entity, is responsible for Base Station configuration, transmission scheduling, and processing of received information. Presentation Interface (PI) text sentences are used to configure the Base Station, schedule message transmissions, and output information.

When TSA and VDM sentences are used, the PSS is responsible for ensuring the integrity of the VDL.

The tests in this standard are for all Base Stations. Additional tests for independent Base Stations are indicated by a note located at the beginning of each appropriate test section.

4.2 Functional block diagram of an AIS Base Station

Figure 1 shows the principal components of the AIS Base Station.

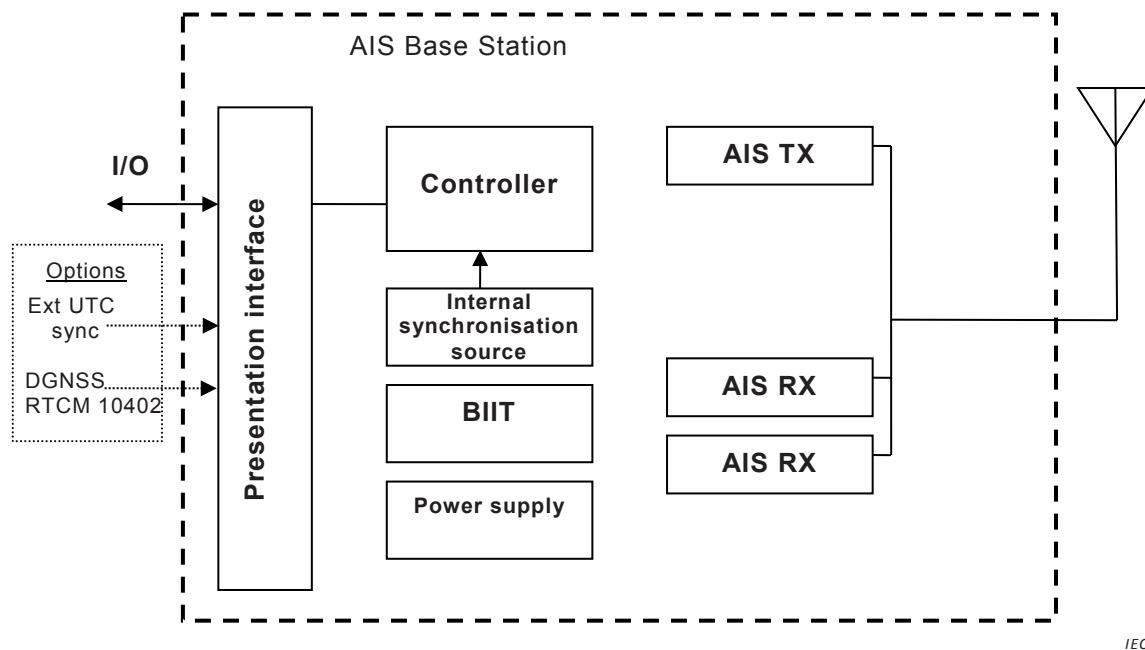

IEC

Figure 1 – Functional block diagram of an AIS Base Station

As a minimum, the following functional elements are required for the AIS Base Station:

- two multi-channel receivers;
- one multi-channel TDMA transmitter;

NOTE Since the minimum configuration of the AIS Base Station has only one transmitter, the AIS Base Station cannot transmit on both AIS Channels (AIS A and AIS B) simultaneously.

- a controlling unit;
- an internal synchronisation source, which may also be used as a position sensor for independent Base Stations. If used as a position source, the internal GNSS receiver shall meet the appropriate requirements of IEC 61108-1;
- a Built-In-Integrity-Test unit (BIIT), which shall provide alarms;
- a power supply;
- a Presentation Interface (PI), which allows the AIS Base Station to exchange sentences with the PSS;
- optional features, for example: DGNSS (RTCM 10402); external synchronisation; DSC functionality.

4.3 General VDL requirements

4.3.1 Sources of VDL messages for transmission

The AIS Base Station interacts with the VDL by receiving and transmitting VDL messages.

In order to transmit VDL messages, the Base Station may derive the messages to be transmitted from three sources:

- a) generate and transmit VDL messages autonomously as per the configuration received via sentences;
- b) generate and transmit VDL messages automatically based on data input received via the PI, using different sentences from that of the VDM;

- c) transmit predefined VDL messages input via the PI. The VDM sentence shall be used to input the content of the VDL messages via the PI to the AIS Base Station. The VDL message shall then be transmitted by the Base Station on the VDL.

When operating the Base Station independently, these three VDL message sources shall be supported in parallel.

When operating the Base Station dependently, only VDM messages received via the PI shall be transmitted as noted in item c) above.

4.3.2 Use of access schemes

4.3.2.1 Dependent operation

When operating as a dependent Base Station the FATDMA access scheme shall be used. The Base Station shall use the slot(s) provided by the combination of linked TSA+VDM sentences. The TSA sentence provides the channel and start slot information. The actual number of slots used is based on the number of bits conveyed by the VDM sentence(s).

Dependent operation shall not use the RATDMA access scheme.

4.3.2.2 Independent operation

The default access scheme for a Base Station shall be FATDMA.

The AIS Base Station may also use RATDMA access schemes if implemented. The AIS Base Station may use the FATDMA and RATDMA access schemes concurrently. The use of pre-reserved FATDMA slots shall take priority over RATDMA access.

When using the FATDMA access scheme, the absolute slot numbers for transmission shall be determined by one of the following methods:

- the PI combination of linked TSA+VDM sentences shall provide the absolute slot number in which the AIS Base Station transmits;
- the AIS Base Station shall autonomously select an appropriate pre-reserved FATDMA slot as determined by its configuration.

Both methods shall be available and operate concurrently.

4.4 Functional diagram for operation of a Base Station

Figure 2 shows the principal components of an AIS Base Station. The diagram identifies the elements of the AIS Base Station and the PI with the PSS.

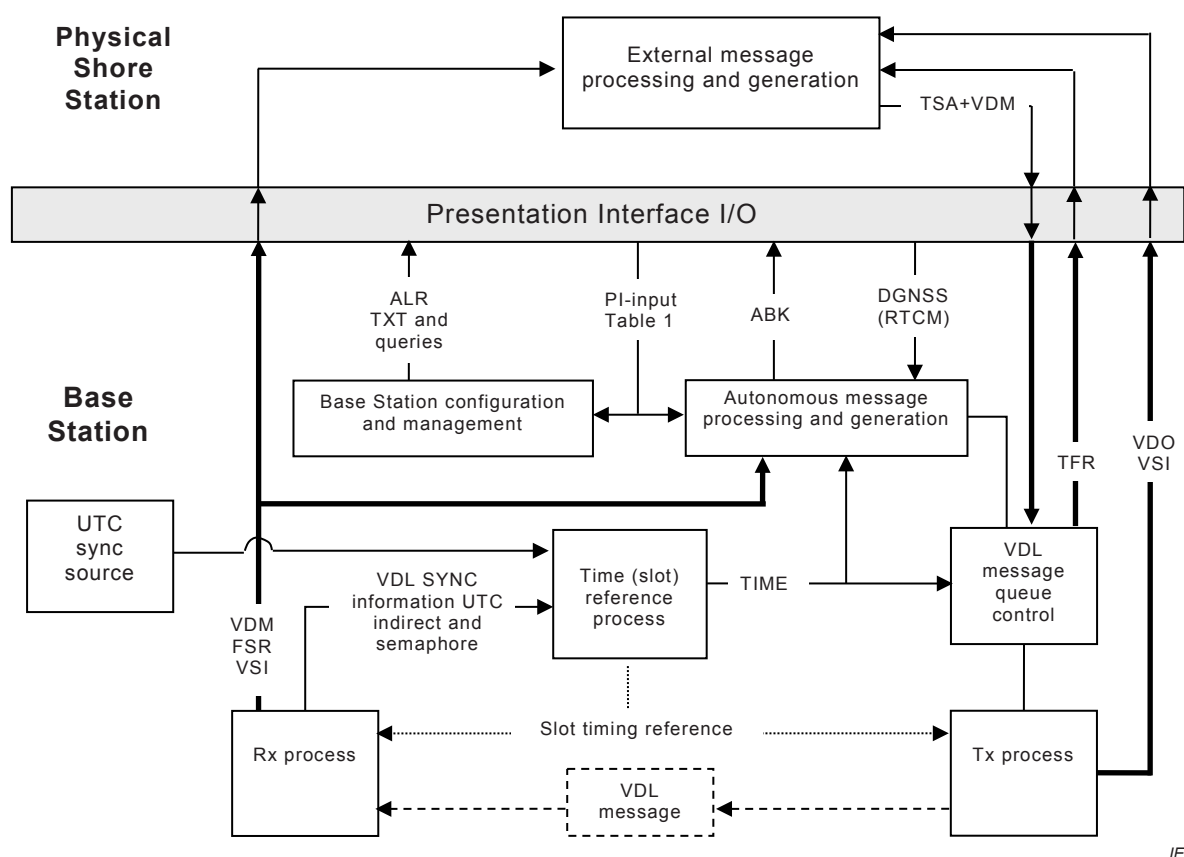

Figure 2 – Functional block diagram dependent and independent operation

The PI of an AIS Base Station consists of at least one input/output port. A specific choice for the physical input/output port is not specified. The purpose of the PI is to:

- exchange VDL messages with the PSS;
- configure the Base Station;
- enable real time control of the Base Station;
- provide an output for BIIT alarms and status.

The information exchange of the PI is supported by a combination of IEC 61162-1 sentences and Base Station sentences (see Table 1).

4.5 Base Station input/output sentence formatters

Table 1 lists sentence formatters used with a Base Station. It includes existing sentence formatters and sentence formatters developed for use with Base Stations. Annex A contains the details for each of the sentence formats developed for AIS Base Stations

Table 1 presents both input and output sentence formatters for dependent and independent operation. For Base Stations that support both independent and dependent operation, both sets of sentences are applicable. For Base Stations that only support dependent operation, the sentences for dependent operation are applicable and all other sentences are ignored.

The TAG block configuration sentences are not included in Table 1. They are in the separate Table 14.

The manufacturer shall declare if legacy configuration sentences are supported (see Annex B). Additionally, the manufacturer shall declare if the legacy comment blocks are

supported. If the manufacturer chooses to support the legacy sentences, all four legacy sentences should be supported. Legacy sentences are marked with footnote ^b in Table 1.

If the manufacturer declares that legacy sentences are supported the input of command sentences without sentence status flags shall be accepted.

Table 1 – Base Station input/output sentence formatters

Sentence formatter	Input independent	Input dependent	Output independent	Output dependent	Description
ABK ^d			X		Addressed and binary broadcast acknowledgement
ABM ^d	X				Addressed binary and safety related message
ACA ^e	X		Q		AIS regional channel assignment message
ACM ^a	X				Preparation and initiation of an AIS Base Station addressed channel message (VDL Message 22)
ACK ^e	X	X			Acknowledge alarm
ADS ^a			X	X	AIS Device Status (output interval configured by BCG and upon status change)
AGA ^a	X		Q		Preparation and initiation of an AIS Base Station broadcast of a group assignment message (Message 23)
AIR ^e	X				AIS interrogation request (VDL Message 15)
ALR ^e			X	X	Set alarm state
ASN ^a	X				Preparation and initiation of an AIS Base Station broadcast of assignment VDL Message 16
BBM ^d	X				Broadcast binary message
BCG ^a	X	X	Q	Q	Base Station configuration, General Command
BCL ^a	X	X	Q	Q	Base Station configuration, Location Command
CBR ^c	X		Q		Configure Broadcast Rate for Message 26
DLM ^a	X		Q		Data Link Management slot allocations for Base Station (VDL Message 20 – FATDMA reservations)
ECB ^a	X		Q		Configure broadcast rates for Base Station messages with epoch planning support
FSR ^a			X	X	Frame summary of AIS reception, defined by SPO. The manufacturer shall declare the parameters that are supported
MEB ^c	X		Q		Message input for Broadcast for Message 26
NAK ^c			X	X	Negative Acknowledgement
RST ^a	X	X	X	X	Equipment Reset Command
SID ^a	X	X	Q	Q	Installation of a station's identification
SPO ^a	X	X	Q	Q	Select AIS device's reception processing and output
TFR ^a			X	X	Transmit feed-back report – Base Station report on status of requested transmission. Automatic

Sentence formatter	Input independent	Input dependent	Output independent	Output dependent	Description
					status response of TSA+VDM
TPC ^a	X				Transmit Slot Prohibit command
TSA ^a	X	X			Transmit Slot Assignment – used to identify AIS time slot used to transmit the content of a VDM sentence. TSA shall precede the VDM sentence
TSR ^a			X		Transmit Slot Prohibit status Report. Automatic status response of TPC
VDM ^e	X	X	X	X	VHF Data-link message
VDO ^e			X	X	VHF Data-link Own-vessel message
VER ^e			Q	Q	Version information about equipment. Provided in response to ABQ
VSI ^a			X	X	VDL Signal Information, defined by SPO. The manufacturer shall declare the parameters that are supported and the corresponding accuracy. The VSI shall follow its associated VDM/VDO
BCE ^b	X	X	Q	Q	General Base Station configuration extended (Replaced by BCG)
BCF ^b	X	X	Q	Q	General Base Station configuration (Replaced by BCL)
CAB ^b	X	X	Q	Q	Control AIS Base Station (Replaced by RST)
TSP ^b	X				Transmit Slot Prohibit command (Replaced by TPC)
NOTE "X" indicates input to, or output from, the AIS Base Station. "Q" indicates that the sentence may be externally requested using the IEC 61162-1 query method.					
^a	See Annex A.				
^b	Optional legacy sentences for backward compatibility. See Annex B.				
^c	See Annex C.				
^d	See IEC 61993-2.				
^e	See IEC 61162-1.				

The AIS Base Station shall output, autonomously and periodically, the ADS sentence on the PI indicating the Base Station status. This shall be output by default once per minute or when there is a change in the status.

The Equipment Status Field of RST shall reflect the reason for reset or restart.

5 Functional definition of the radio interface of the AIS Base Station

5.1 General requirements of the physical layer

The following general requirements apply to all receivers and transmitter:

- a Base Station shall use simplex channels or duplex channels in either full-duplex or half-duplex mode;
- a Base Station shall be capable of 25 kHz emission/reception in accordance with ITU-R M.1084-4, Annex 3 (as referenced by Recommendation ITU-R M.1371);

- a Base Station shall be capable of transmitting using at least two different power settings, as provided for by ITU-R M.1371. The Base Station shall have the capability to set its power level as stipulated by an input command;
- a Base Station shall be capable of measuring RSSI of received messages on either channel.

5.2 Required parameter settings for the physical layer of the AIS Base Station

Table 2, Table 3 and Table 4 are derived from Recommendation ITU-R M.1371 and give the parameters required for an AIS Base Station.

NOTE For the meaning of the symbols and additional information refer to the appropriate clause of Recommendation ITU-R M.1371.

The constants of the physical layer of the AIS Base Station shall comply with the values given in Table 3 and Table 4.

Table 2 – Required parameter settings for an AIS Base Station

Symbol	Parameter name	Low setting	High setting
PH.RFR	Regional frequencies	156,025 MHz	162,025 MHz
PH.CHS	Channel spacing	25 kHz	25 kHz
PH.AIS1	AIS 1 (default channel 1)	161,975 MHz	161,975 MHz
PH.AIS2	AIS 2 (default channel 2)	162,025 MHz	162,025 MHz
PH.CHB	Channel bandwidth	25 kHz	25 kHz
PH.BR	Bit rate	9 600 bit/s	9 600 bit/s
PH.TS	Training sequence Always start with a zero (0101010...)	24 bit	24 bit
PH.TST	Transmitter settling time (Transmit power within 20 % of final value, frequency stable to within 1,0 kHz of final value)	≤1,0 ms	≤1,0 ms

Table 3 – Required settings of physical layer constants

Symbol	Parameter name	Value
PH.DE	Data encoding	NRZI
PH.FEC	Forward error correction	Not used
PH.IL	Interleaving	Not used
PH.BS	Bit scrambling	Not used
PH.MOD	Modulation	Bandwidth adapted; GMSK (see Table 4)

Table 4 – Bandwidth related parameters of the physical layer of the AIS Base Station

Symbol	Parameter name	PH.CHB
PH.TXBT	Transmit BT-product	0,4
PH.RXBT	Receive BT-product	0,5
PH.MI	Modulation index	0,50

5.3 Minimum requirements for the TDMA transmitter of the AIS Base Station

The minimum technical characteristics as specified in Table 5 shall apply to the TDMA transmitters.

Table 5 – Minimum required TDMA transmitter characteristics

Transmitter parameters	Requirement	Condition
Frequency error	± 500 Hz normal $\pm 1\ 000$ Hz extreme	
Carrier power (P_{ss})	41 dBm high power setting 30 dBm low power setting	$\pm 1,5$ dB normal and ± 3 dB extreme, conducted
Modulation spectrum (slotted transmission)	0 dBc below straight line between -25 dBc at ± 10 kHz and -70 dBc at ± 25 kHz -70 dBc or -36 dBm whatever is higher.	$\Delta f_c < \pm 10$ kHz ± 10 kHz $< \Delta f_c < \pm 25$ kHz ± 25 kHz $< \Delta f_c < \pm 62,5$ kHz
Intermodulation attenuation	≥ 40 dB	
Modulation accuracy	$< 3\ 400$ Hz $2\ 400$ Hz ± 480 Hz $2\ 400$ Hz ± 240 Hz normal ± 480 Hz extreme $1\ 740$ Hz ± 175 Hz normal ± 350 Hz extreme $2\ 400$ Hz ± 240 Hz normal ± 480 Hz extreme	Bit 0, 1 Bit 2, 3 Bit 4 ... 31 Test signal 0101... Test signal 00001111...
Power versus time characteristics	Transmission delay: 0 s Ramp up time: 833 μ s Ramp down time: 833 μ s Transmission duration: $\leq 26\ 624$ μ s	See Figure 4 and Table 6 Nominal 1 time slot transmission
Spurious emissions	-36 dBm -30 dBm	9 kHz 1 GHz 1 GHz 4 GHz

The emission mask for 25 kHz channel mode is:

- at ± 10 kHz removed from the carrier, the modulation sidebands are below -25 dBc;
- at ± 25 kHz to $\pm 62,5$ kHz removed from the carrier, the modulation sidebands are below -70 dBc, with no need to be below -36 dBm;
- in the region between ± 10 kHz and ± 25 kHz removed from the carrier, the modulation sidebands shall be below a line specified between these two points.

The emission mask for 25 kHz channel mode (see Figure 3) is as follows.

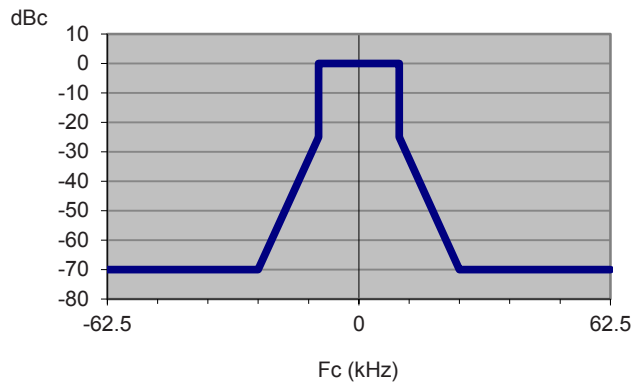

IEC

Figure 3 – Modulation spectrum for slotted transmission

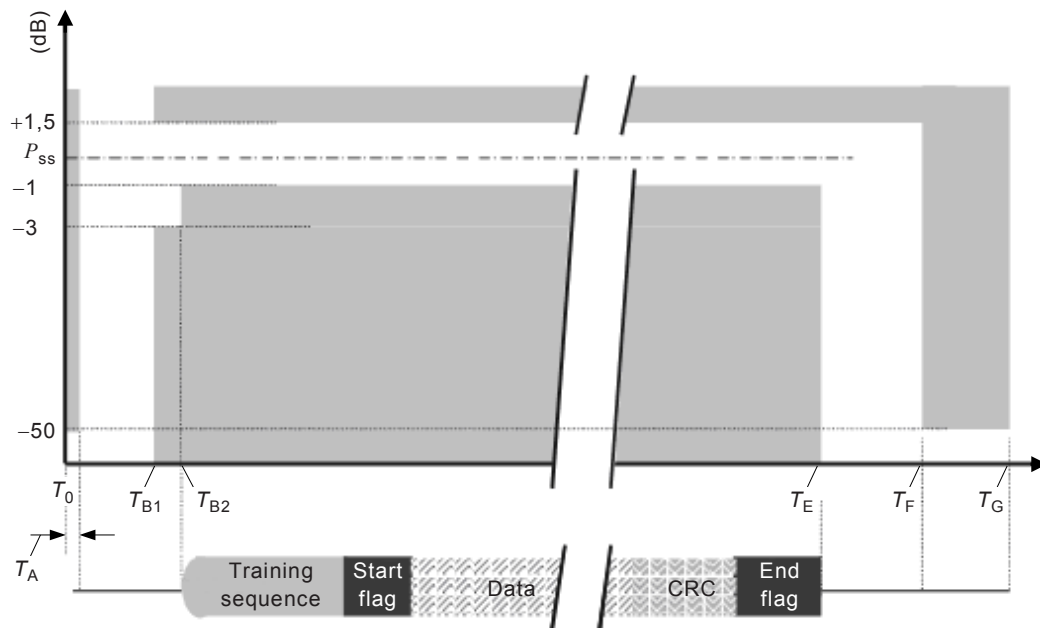

IEC

Figure 4 – Power versus time mask

Table 6 – Definition of timings for Figure 4

Reference	Bits	Time	Definition	
T_0	0	0 ms	Start of transmission slot. Power shall NOT exceed -50 dB of P_{ss} before T_0	
T_A	0 to 6	0 ms to 0,625 ms	Power exceeds -50 dB of P_{ss}	
T_B	T_{B1}	6	0,625 ms	Power shall be within $+1,5$ or -3 dB of P_{ss}
	T_{B2}	8	0,833 ms	Power shall be within $+1,5$ or -1 dB of P_{ss}
T_E (includes 1 stuffing bit)	233	24,271 ms	Power shall remain within $+1,5$ or -1 dB of P_{ss} during the period T_{B2} to T_E	
T_F (includes 1 stuffing bit)	241	25,104 ms	Power shall be -50 dB of P_{ss} and stay below this	
T_G	256	26,667 ms	Start of next transmission time period	

There shall be no modulation of the RF after the termination of transmission (T_E) until the power has reached zero and next slot begins (T_G). Note that bits take priority over time in applying the mask. Milliseconds are provided for guidance.

The AIS installation, when operating, should not be damaged by the effects of open circuited or short circuited antenna terminals.

5.4 Minimum requirements for the TDMA receivers of the AIS Base Station

The minimum technical characteristics as specified in Table 7 shall apply to the TDMA receivers.

Table 7 – Minimum TDMA receiver characteristics

Receiver parameters	25 kHz channels
Sensitivity	20 % PER at -107 dBm
Maximum error at high input levels	1 % PER at -7 dBm 1 % PER at -77 dBm
Co-channel rejection	20 % PER at -10 dB
Adjacent channel selectivity	20 % PER at 70 dB
Spurious response rejection	20 % PER at 70 dB
Intermodulation response rejection	20 % PER at 74 dB
Blocking	20 % PER at 86 dB
Accuracy of RSSI measurement	±3 dB at -50 to -107 dBm
Spurious emissions	9 kHz 1 GHz: -57 dBm 1 GHz 4 GHz: -47 dBm

5.5 Shutdown procedure for an AIS Base Station

An automatic transmitter hardware shutdown procedure and indication shall be provided in case a transmitter continues its transmission at the end of its transmission period. This feature shall be independent of the Base Station software control. The AIS Base Station shall shut down the TDMA transmitter in less than 2 s.

6 Requirements for AIS Base Station

6.1 General

This clause describes the requirements for a Base Station operating as a dependent or independent station.

The Base Station may be operated as an independent station that contains all of the functionality or as a dependent station that relies on external functionality. It is the responsibility of the competent authority to ensure proper operation.

When operated as a dependent Base Station, the unit operates under full control of the PSS.

When operated as an independent Base Station, the unit may be delegated certain autonomous functionality under the supervisory control of the PSS.

6.2 Dependent Base Station requirements

6.2.1 General rules

When operating as a dependent Base Station, the unit shall comply with the following general rules:

- each dependent AIS Base Station shall, as a default, be identified by its own individual MMSI on the VDL interface and the unique identifier on the PI interface. The AIS Base Station MMSI and unique identifier shall be configurable by means of a SID sentence via the PI;
- the dependent AIS Base Station shall be capable of transmitting messages with a different MMSI provided by the PSS by means of a standard VDM input sentence;
- the dependent AIS Base Station shall be able to receive all VDL messages;
- every received VDL message shall be passed to the PI as a VDM sentence without further data content processing;
- every received PI VDM sentence shall be transmitted on the VDL channel and beginning in the slot indicated by the linked TSA sentence without further data content processing;
- every message transmitted on the VDL shall be passed to the PI as a VDO sentence linked with a VSI sentence;
- the dependent AIS Base Station does not transmit Message 4 without PSS control;
- all transmissions are done via TSA+VDM PI input sentences;
- the dependent AIS Base Station shall not be semaphore qualified and shall not operate autonomously;
- when the UTC sync source is unavailable, the AIS Base Station shall use UTC indirect or shall be synchronised to another Base Station. Propagation delay shall be taken into consideration;
- upon request via the sentence VER, the dependent AIS Base Station shall provide its hardware and software version information.

6.2.2 General processing diagram

The AIS Base Station shall internally process data in accordance with Figure 5.

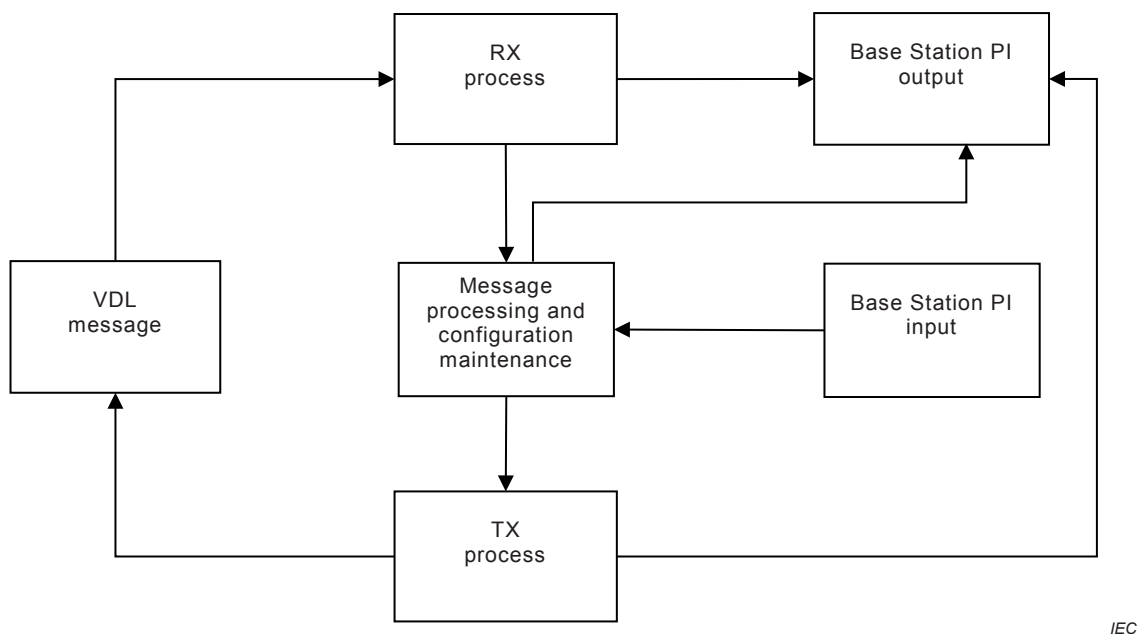

Figure 5 – General processing diagram

6.2.3 AIS Base Station response to PI input

The AIS Base Station shall respond to input sentences from the PI in accordance with Table 1, “output dependent” when operating as a dependent Base Station.

6.2.4 AIS Base Station response to VDL input

The AIS Base Station shall respond to input messages from the VDL in accordance with Table 8.

Table 8 – Base Station response to input messages from the VDL

VDL input	Resulting PI output	Resulting VDL output	Resulting VDL reporting rate
Any message (regardless of MMSI)	VDM, VSI	Nil	Nil
All messages in a frame (regardless of MMSI)	FSR	Nil	Nil

The required content of the FSR output is given in Table 10.

6.3 Independent Base Station requirements

6.3.1 General rules

Requirements for Base Stations operating as independent units are in addition to the requirements for Base Stations operating as a dependent unit.

When operating as an independent Base Station, the unit shall comply with the following general rules:

- with regard to the access schemes to the VDL, refer to 6.3.4 AIS Base Station interaction on the VDL;

- the independent AIS Base Station shall, as a default, use a surveyed position. When using a surveyed position, the “position accuracy” flag in VDL Message 4 shall be set upon configuration, and the “RAIM” flag shall be set to 0;
- when the UTC sync source is unavailable, the independent AIS Base Station shall use UTC indirect or the semaphore rules as defined by ITU-R M.1371;
- the independent AIS Base Station shall revert to semaphore behaviour upon detection of semaphore condition on the VDL;
- all VDL messages shall be as short as possible.

Note that in order to behave as a semaphore, the independent AIS Base Station is transmitting Message 4. The required increase of the reporting rate is autonomous. This behaviour is not influenced by FATDMA or RATDMA.

6.3.2 General processing diagram

The AIS Base Station shall internally process data in accordance with Figure 6.

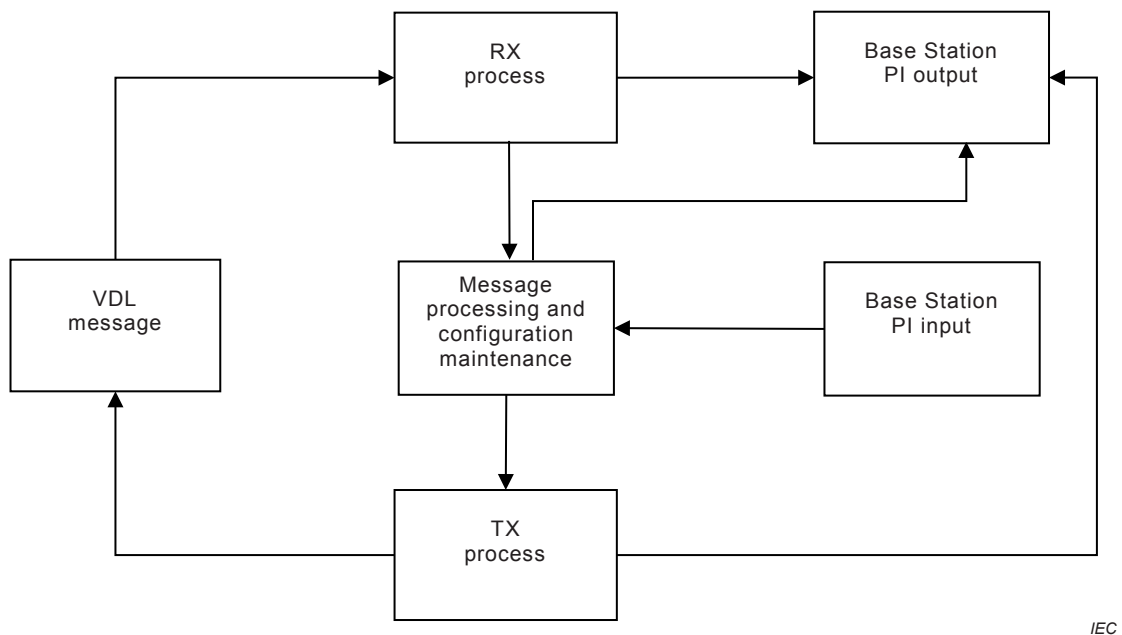

Figure 6 – General processing diagram

6.3.3 AIS Base Station response to PI input

6.3.3.1 General

The AIS Base Station shall respond to input sentences from the PI in accordance with Table 1, “output independent” when operating as an independent Base Station.

6.3.3.2 Requirements for configuration of FATDMA access scheme (Link Management Message)

Use of FATDMA is reserved for Base Stations operating as either dependent or independent.

6.3.3.3 Slot reuse

A Base Station’s transmission slots are protected by reservation of slots (Message 4 and 20) and the 120 nautical mile rule. Slots allocated or reserved by other Base Stations should not be used for RATDMA unless the other Base Station is located over 120 nautical miles from the Base Station.

6.3.3.4 Configuration of Data Link Management Messages

The Data Link Management Message (Message 20) is a continuously scheduled and transmitted message. The Data Link Management Message applies only to the frequency channel on which it is transmitted.

The Data Link Management Message shall be used by Base Station(s) to pre-announce the fixed allocation schedule (FATDMA) for one or more Base Station(s) and it shall be repeated as often as required.

The AIS Base Station shall use the ECB sentence to schedule the autonomously and continuously transmission of Data Link Management Messages, which refresh the FATDMA reservations.

6.3.4 AIS Base Station interaction on the VDL

6.3.4.1 General

The interaction of the AIS Base Station on the VDL is presented in Table 9. The required content of the VSI sentence is given in Table 10.

Table 9 – Base Station response to input messages from the VDL

VDL input	Resulting PI output	Resulting VDL output	Resulting VDL reporting rate
Any message (regardless of MMSI)	VDM, VSI ^c	Nil	Nil
Message 6 own MMSI	VDM, VSI ^c , VDO	Message 7	Once
Message 7 own MMSI	VDM, VSI ^c , ABK	Nil	Nil
Message 10 own MMSI	VDM, VSI ^c , VDO	Message 4	Once
Message 12 own MMSI	VDM, VSI ^c , VDO	Message 13	Once
Message 13 own MMSI	VDM, VSI ^c , ABK	Nil	Nil
Message 15 own MMSI	VDM, VSI ^c , VDO	Message 4 ^a or 24A/B ^b	Once
Semaphore qualified	VDO, VSI ^c	Message 4	3 1/3 s
Not semaphore qualified	VDO, VSI ^c	Message 4	10 s

^a If the AIS Base Station is set up for autonomous transmission, then the reply is on the next scheduled transmission. If the Base Station is not set up for autonomous transmission, then the Base Station shall respond within 4 s only if it is configured for RATDMA or FATDMA.

^b A base station shall respond with Message 24A and 24B within 4 s only if it is configured for RATDMA or FATDMA.

^c If VSI enabled.

Table 10 – Required content of FSR and VSI output

Sentence	Field	Requirement
FSR	Hour, minute and second of report generation	Required
FSR	Channel being reported	Required
FSR	Total slots occupied by valid message received previous frame	Required
FSR	Total slots occupied by this station's transmissions previous frame	Required
FSR	Number of slots with CRC failures in the previous frame	Required
FSR	Total external slot reservations for current frame	Required
FSR	Average noise level during previous frame	Optional
FSR	Number of slots with received signal strength (at least 10 dB over average noise level). This includes slots with valid messages.	Optional
VSI	Hour, minute and second, and fractional-second of measurement	Required
VSI	First slot number of message	Required
VSI	Signal strength (dBm) of received VDL message.	Required
VSI	Signal to noise ratio (dB)	Optional

6.3.4.2 Transmission of DGNSS corrections

There are two possible ways to accept DGNSS corrections for transmission:

- as a result of a VDM sentence via the PI. All required information for transmission is included in the VDM sentence;
- via the dedicated optional DGNSS input port.

This standard provides tests for the VDM DGNSS corrections. A separate test for RTCM 10402 input data via the dedicated optional DGNSS port is provided in 10.6.

6.3.4.3 Autonomous Base Station report Message 4

The independent Base Station shall periodically generate the Base Station report (Message 4) with a reporting interval of 10 s according to its given configuration. The Base Station shall operate in this state until it detects that it is required to operate as semaphore. The Base Station shall then increase its update rate of Message 4 to MAC SyncBaseRate (one report per 3 1/3 s). Three minutes after the requirement for the Base Station to be semaphore has ceased it shall revert to the 10 s reporting interval.

6.3.4.4 Autonomous Tx of data link management messages

The DLM PI sentence shall be used to set up the link for use by the Base Station.

6.3.4.5 Requirements for acknowledgement/retries configuration

The number of retries for addressed messages as described in ITU-R M.1371 shall be input by configuration sentence BCG.

6.3.4.6 Requirements for assigned mode commands

Assignment commands shall be transmitted by a Base Station when operating as a controlling entity. The Base Station shall be able to assign a specified transmission schedule to a mobile station.

The reporting rate assigned by a Base Station shall be, as a minimum, 20 reports per 10 min and, as a maximum, 1 report per second.

The Base Station shall be capable of assigning two mobile stations simultaneously.

6.3.4.7 Autonomous response to interrogation

When a Base Station receives a Message 15 from a mobile station, it shall automatically provide a single response with the message number indicated by the Message 15 (see Table 9).

6.3.4.8 Requirements for the preset of the repeat-indicator

The independent Base Station shall preset the repeat indicator for own transmissions of all VDL messages to a value between 0 and 3 in accordance with Recommendation ITU-R M.1371. If no configuration was received, the AIS Base Station shall use the default value of zero.

NOTE By pre-set of the repeat indicator by non zero, the Base Station is disqualified from becoming an indirect sync source.

6.3.4.9 Requirements for messages initiated by ABM, BBM or AIR

The independent Base Station shall be able to receive ABM, BBM and AIR sentences on the PI, and it shall transmit the messages according to Table 11 in response to these sentences. The access scheme shall be either FATDMA or RATDMA according to the description in 6.3.4.10.

Table 11 – Base Station response to ABM, BBM and AIR input on the PI

Message type	PI input	PI output	Remarks
Message 6	ABM	VDO, ABK	
Message 8	BBM	VDO, ABK	
Message 10	AIR	VDO, ABK	
Message 12	ABM	VDO, ABK	
Message 14	BBM	VDO, ABK	
Message 15	AIR	VDO, ABK	
Message 25 Addressed	ABM	VDO, ABK	
Message 25 Broadcast	BBM	VDO, ABK	
Message 26 Addressed	ABM	VDO, ABK	
Message 26 Broadcast	BBM	VDO, ABK	

6.3.4.10 AIS Base Station response to VDM input

The Base Station shall transmit, on the VDL, VDM sentences received on the PI.

FATDMA shall be used as the access scheme for transmission. RATDMA may also be configured for use.

A transmission initiated by a VDM input shall not replace a scheduled message.

Messages 4, 11 and 20 shall not be transmitted.

Messages 15 and 16 shall not be transmitted if a slot offset is provided unless the slot offset is recalculated by the base station. Messages that have a Comm.state shall have the

Synch.state bits of the Comm.state set to the current status of the station. The remaining Comm.state bits shall be set to zero to prevent false slot allocations.

The repeat indicator shall be set to greater than zero before transmitting.

Any Message up to 27 shall be transmitted according to these rules.

After receiving a VDM sentence, the Base Station responds with the appropriate TFR sentence.

The following rules shall be used for VDL transmission (as shown in Figure 7):

- the VDL message shall be transmitted in available FATDMA slots;
- NOTE Available FATDMA slots are local 'L' slots without planned ECB transmissions.
- if FATDMA slots are not available within 4 s and RATDMA is available, then RATDMA shall be used;
 - if RATDMA is not available, and if there is an available FATDMA slot within 6 min, it shall be used;
 - if FATDMA and RATDMA are not available, there shall be no transmission and the VDM is discarded.

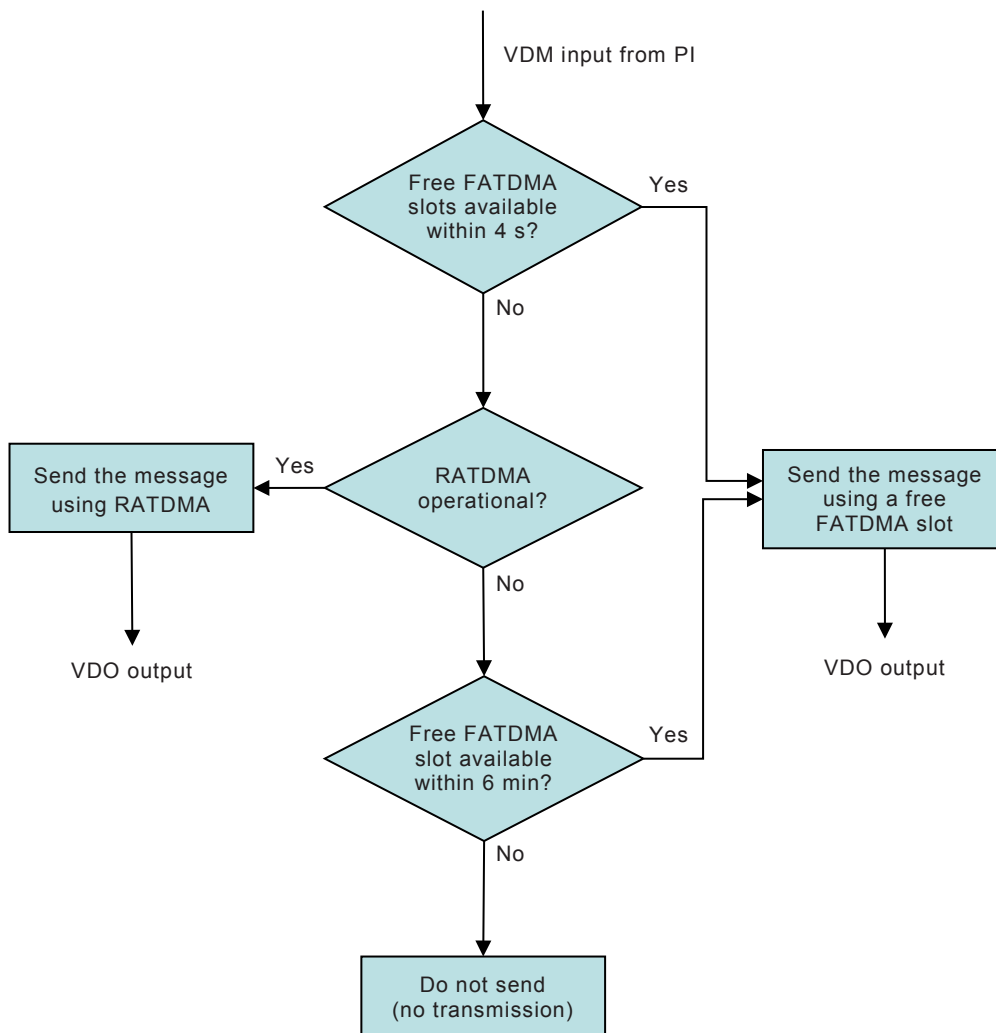

IEC

Figure 7 – Flow diagram for AIS Base Station response to VDM input

6.3.4.11 Scheduled transmission of Message 24A

The Base Station shall be configurable for a scheduled transmission of Message 24A providing the base station name. This will be configured using the ECB sentence. The definition of the ECB sentence includes the definition of a transmission schedule for Message 24. The base station name is set using the BCL sentence.

6.3.4.12 Scheduled transmission of Message 26

The Base Station shall be configurable for up to 4 transmission schedules for Message 26. These will be configured using the CBR sentence. The content of Message 26 is set using the MEB sentence. A payload can be stored for each message ID index of the scheduled Message 26. If a MEB has not been provided for a particular message ID index, there shall be no transmission of the associated Message 26.

6.3.4.13 Requirements for management of mobile AIS stations by AIS Base Station

The following operational settings for mobile AIS stations shall be controlled by an AIS Base Station:

- a) regional area designation;
- b) regional working frequencies assignment;
- c) power level;
- d) Tx/Rx mode;
- e) transitional zone size;
- f) reporting rate;
- g) slot use (reservation);
- h) control of long-range broadcast Message 27.

The Base Station shall be able to control the transmission of Message 27 from the mobile stations within its coverage area. The coverage area is transmitted to the mobile stations using Message 23.

The Base Station shall be capable of storing a group assignment area for each station type.

To delete a group assignment area, an AGA sentence with station type (that is to be deleted) and default position, shall be sent to the Base Station.

Message 4 contains a bit called “transmission control for long-range broadcast message”. When this bit is set to 1, the mobile station shall transmit Message 27 if located within the coverage area of the Base Station transmitting the Message 4, as defined by Message 23.

6.3.5 Autonomous channel management

The ACA sentence shall be used to set up the channel management information for the AIS Base Station which shall result in transmission of Message 22. Transmission shall be in a sequential order.

The “in use” data field of the ACA sentence defines the status of the region (0 = not in use, 1 = in use). The Base Station shall support 8 regions.

If optional DSC functionality is included, the ACA sentence may be used for DSC channel management.

6.4 BIIT conditions

The AIS Base Station shall monitor the following BIIT conditions and shall generate the appropriate ALR sentences on the PI. The ALR sentence shall be output at least once per minute. The alarm conditions are noted in Table 12 and the resulting alarm status is sent via PI sentence ADS. If an alarm is active (acknowledged or not), the ADS alarm status field is set to A; if no alarm is active the field is set to V.

Table 12 – BIIT alarm conditions monitored by an AIS Base Station

Alarms description text	Alarm condition threshold exceeded	Alarm condition not exceeded	Alarm ID or text identifier	Reaction of the system to the alarm condition threshold exceeded
AIS: Tx malfunction	A	V	001	Stop transmission
AIS: Antenna VSWR exceeds limit	A	V	002	Continue operation
AIS: Rx channel A malfunction	A	V	003	Stop transmission on affected channel
AIS: Rx channel B malfunction	A	V	004	Stop transmission on affected channel
AIS: General failure	A	V	006	Stop transmission
AIS: Clock lost	A	V	007	Independent – follow synchronisation rules including semaphore. Dependent – follow synchronisation rules. Stop transmission when there is no synchronisation source.
AIS: No sensor position in use	A	V	026	Continue operation
AIS: Frame synchronisation failure	A	V	037	Stop transmission
AIS: DGNSS input failed ^a	A	V	038	Continue operation
A Alarm.				
V Valid.				
^a Optional.				

6.5 Default settings after reset

The Base Station shall have the configuration settings after a reset command given in Table 13.

Table 13 – Settings after reset command

Parameter	Sentence	Reset value/ action
Channel management area settings	ACA	No channel management areas
RATDMA on/ off	BCG (BCE)	0 = off
UTC source selection	BCG (BCE)	1 = internal source
ADS interval	BCG (BCE)	60 s
Rx and Tx channel A	BCG (BCF)	2 087
Rx and Tx channel B	BCG (BCF)	2 088
Power level channel A and B	BCG (BCF)	0 = high power
VDL message retries	BCG (BCF)	3
Message repeat indicator	BCG (BCF)	0

Parameter	Sentence	Reset value/ action
Talker ID	BCG (BCF)	Not changed
Position source	BCL (BCF)	1 = internal EPFS in use
Own position, Latitude	BCL (BCF)	91°
Own position, Longitude	BCL (BCF)	181°
Position accuracy	BCL (BCF)	0
Base station name	BCL	No name
Message 27 transmission control bit in Message 4	BCL	Tx control bit = 0
Slot reservations	DLM	No reservations
Transmission schedules for Message 4, 17, 20, 22, 23, 24	ECB	No active transmission schedules
Transmission schedules for Message 26	CBR	No active transmission schedules
Content of scheduled Message 26	MEB	No content stored
Unique identifier	SID	Not changed
MMSI	SID	Not changed
VSI and FSR output	SPO	VSI and FSR disabled, All output values disabled
TAG blocks g = grouping	CPG	Not changed
TAG blocks d = destination	CPD	Not changed
TAG blocks s = source	CPS, TBS	Not changed
TAG blocks c = UNIX time	CPC	Not changed
TAG blocks n = line-count	CPC	Not changed
Legacy support		
Channel A transmission	(CAB)	1 = Tx on
Channel B transmission	(CAB)	1 = Tx on
Comment Block Control	(BCE)	Not Changed

6.6 Further requirements for optional features

6.6.1 General

This subclause describes features that are optional for both dependent and independent operation of AIS Base Stations. If an option is selected, then the AIS Base Station shall comply with the requirements of the option selected, and this option shall be tested.

NOTE Tests for all optional features are not included within this standard.

6.6.2 External synchronisation source option

The AIS Base Station may use an external synchronisation source via a dedicated input port. If used, the external synchronisation source shall have accuracy sufficient for the base station to maintain slot jitter within the $\pm 52 \mu\text{s}$ requirement.

The UTC synchronisation source in use shall be configurable by the sentence BCG.

The dedicated input port for external UTC synchronisation may consist of:

- pulse per second (PPS) detailed setting subject to configuration;
- UTC date and time.

6.6.3 DGNSS dedicated port option

The AIS Base Station may be configured to transmit DGNSS corrections (Message 17) that are input via a dedicated RTCM 10402 format DGNSS port.

Base Stations shall convert the RTCM 10402 format to VDL format before transmission.

This option shall only be available for the independent operation and care should be taken to minimise the impact on the VDL.

7 Functional definition of the presentation interface of the AIS Base Station

7.1 Physical requirements for the presentation interface

An interface shall be provided to handle the data bandwidth requirements of the PI.

7.2 Presentation interface data exchange

7.2.1 General

Regardless of the physical interface used, the AIS Base Station shall exchange data using the sentences defined in Table 1 and Table 14.

7.2.2 Base Station presentation interface output

Table 1 includes the list of output sentences.

All transmitted VDL messages shall be output by VDO sentences. The UTC hour, UTC minute (frame), and slot number of the slot or the first slot of a multi-slot message in which each VDL message was transmitted shall be provided by linking a VDO to a VSI sentence.

Each output sentence is identified by the talker identifier as configured by the BCG sentence.

7.2.3 Base Station presentation interface input

Regardless of the physical interface implemented, the AIS Base Station shall accept data input conforming to Table 1 which lists the mandatory sentences for each type of Base Station.

7.2.4 TAG blocks on presentation interface

Table 14 shows the TAG block functions required for a Base Station as defined in Annex D. A description of the use of TAG blocks is given in NMEA 0183.

Table 14 – Required TAG block functions

Sentence	Associated parameter	Required input function	Required output function
CPC	"c" = Unix time parameter	No evaluation on input required	Output of time tag (current UTC time) with all output sentences, 0 if not available. Required accuracy of ± 1 s.
CPD	"d" = Destination-Identification	Filtering of input sentences based on own UI (configured by SID sentence)	Output of Destination identification Tag in all responses
CPG ^a	"g" = sentence Grouping	No evaluation required	Grouping of related sentences, VDM and VDO with a VSI sentence and multi-part sentences
CPN ^b	"n" = line count	No evaluation required	Output of line count Tag with all

Sentence	Associated parameter	Required input function	Required output function
			output sentences
CPS	"s" = Source identification	Filtering of input sentences based on Source identifications configured by TBS sentence	Output of Source identification TAG with own UI attached to NAK responses or to all output sentences
TBR	TAG block report request	Response with at least CPD, CPG, CPS, CPC, CPN	No TBR output
TBS	"s" = Source identification	Configuration of at least 5 different Source identifications for input filtering	Response on query for TBS
^a The minimum required: Group-code Increment = 1. The Reset Event = 0. Initial Group-code = 1. Group-code Limit = 1-999999999.			
^b The minimum required: Count Increment = 1. The Reset Event = 0. Initial Line-count = 1. Line-count Limit = 1-999999999.			

8 Tests of AIS Base Stations – Method of measurement and required results

8.1 General

Physical test parameters and testing subject to national requirements may override parameters stated below. These parameters are stated as a guideline only.

8.2 Test conditions

8.2.1 Normal test conditions

8.2.1.1 Temperature and humidity

Temperature and humidity shall be within the following range:

Temperature +15 °C to + 35 °C

Humidity 20 % to 75 %

8.2.1.2 Power supply

The normal power supply for the tests shall be as specified by the manufacturer.

8.2.2 Extreme test conditions

The extreme temperature conditions are –15 °C and +55 °C. Where required, tests under extreme test conditions shall be a combination of

- dry heat and upper limit of supply voltage applied simultaneously, and
- low temperature and lower limit of supply voltage applied simultaneously.

During type testing, the power source to the equipment may be replaced by a test power source, capable of producing normal and extreme test voltages.

8.2.3 Standard test environment

The EUT is tested in an environment using test equipment to simulate and to log VDL messages. Standard environment consists of at least 5 simulated targets. The signal input level at the RF input port of the EUT for any simulated target shall be at least –100 dBm. Own position sensor inputs to the EUT will be simulated by the test system or other means.

Channels in use shall be selected by manual input before starting the tests.

8.2.4 Test signals

8.2.4.1 Standard test signal number 1

For TDMA Type 1: A test signal consisting of a 26 ms packet (1 slot) of 010101.

8.2.4.2 Standard test signal number 2

For TDMA Type 2: A test signal consisting of a 26 ms packet (1 slot) of 00001111.

8.2.4.3 Standard test signal number 3

This test signal consists of 200 packets grouped into clusters of 4 as described in Figure 8 and Table 15. Each cluster consists of 2 consecutive transmissions of packets. NRZI shall be applied to every packet. After sending packet 1 and 2, the initial state of the NRZI process shall be inverted and then packet 1 and 2 repeated.

Between every transmitted packet there shall be at least 2 free slots. The RF carrier shall be switched off between packets to simulate slotted behaviour.

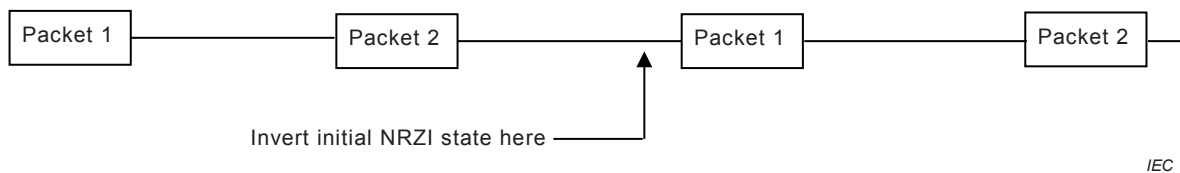

Figure 8 – Format for repeating four-packet cluster

Table 15 – Content of first two packets

Packet	Parameter	Bits	Contents	Comment
1	Training	24	0101...0101	
	Start flag	8	01111110	
	Data	168	Pseudo random	As per Table 16
	CRC	16	Calculated	
	End flag	8	01111110	
2	Training	24	1010...1010	
	Start flag	8	01111110	
	Data	168	Pseudo random	As per Table 16
	CRC	16	Calculated	
	End flag	8	01111110	

Table 16 – Fixed PRS data derived from ITU-T O.153

Address	Contents (HEX)							
0-7	0x04	0xF6	0xD5	0x8E	0xFB	0x01	0x4C	0xC7
	0000.0100	1111.0110	1101.0101	1000.1110	1111.1011	0000.0001	0100.1100	1100.0111
8-15	0x76	0x1E	0xBC	0x5B	0xE5	0x92	0xA6	0x2F
	0111.0110	0001.1110	1011.1100	0101.1011	1110.0101	1001.0010	1010.0110	0010.1111
16-20	0x53	0xF9	0xD6	0xE7	0xE0	21 B = 168 bit (+4 stuffed bit), CRC = 0x3B85		
	0101.0011	1111.1001	1101.0110	1110.0111	1110.0000			

8.2.5 Arrangements for test signals applied to the receiver input

Sources of test signals for application to the receiver input shall be connected in such a way that the source impedance presented to the receiver input is 50 Ω.

The impedance shall be met irrespective of whether one or more signals using a combining network are applied to the receiver simultaneously.

The levels of the test signals at the receiver input terminals (RF socket) shall be expressed in terms of dBm.

The effects of any intermodulation products and noise produced in the test signal sources shall be negligible.

8.2.6 Encoder for receiver measurements

Whenever needed, and in order to facilitate measurements on the receiver, an encoder for the data system shall accompany the EUT, together with details of the normal modulation process. The encoder is used to modulate a signal generator for use as a test signal source.

Complete details of all codes and code format(s) used shall be given.

8.2.7 Waiver for receivers

If the manufacturer declares that both TDMA receivers are identical, the test shall be limited to one receiver and the test for the second receiver shall be waived. The test report shall include this.

8.2.8 Impedance

In this standard, the term "50 Ω" is used for a 50 Ω non-reactive impedance.

8.2.9 Artificial antenna (dummy load)

Tests shall be carried out using an artificial antenna, which shall be a non-reactive, non-radiating load of 50 Ω connected to the antenna connector.

8.2.10 Facilities for access

All tests shall be performed using the standard ports of the EUT. Where access facilities are required to enable any specific test, these shall be provided by the manufacturer.

8.2.11 Operation of the transmitter

For the purpose of the measurements according to this standard, there shall be a facility to operate the transmitter unmodulated.

Alternatively, the method of obtaining an unmodulated carrier or special types of modulation patterns may also be decided by agreement between the manufacturer and the test laboratory. The method used shall be described in the test report and may involve suitable temporary internal modifications of the equipment under test.

NOTE For example, in the case of direct Frequency Shift Keying (FSK), a means to continuously transmit a sequence containing only "zeros" and a sequence containing only "ones" is preferable.

8.2.12 Measurement uncertainties

Maximum values of absolute measurement uncertainties are given in Table 17.

Table 17 – Maximum values of absolute measurement uncertainties

RF frequency	$\pm 1 \times 10^{-7}$
RF power	$\pm 0,75$ dB
Adjacent channel power	± 5 dB
Conducted spurious emission of transmitter	± 4 dB
Conducted spurious emission of receiver	± 3 dB
Two-signal measurement	± 4 dB
Three-signal measurement	± 3 dB
Radiated emission of transmitter	± 6 dB
Radiated emission of receiver	± 6 dB
Transmitter attack time	± 20 %
Transmitter release time	± 20 %

For the test methods according to this standard, these uncertainty figures are valid to a confidence level of 95 %.

The interpretation of the results recorded in a test report for the measurements described in this standard shall be as follows:

- the measured value related to the corresponding limit shall be used to decide whether equipment meets the requirements of this standard;
- the actual measurement uncertainty of the test laboratory carrying out the measurements, for each particular measurement, shall be included in the test report;
- the values of the actual measurement uncertainty shall be, for each measurement, equal to or lower than the figures given in this clause (absolute measurement uncertainties).

9 Physical radio tests

9.1 Remark

Unless otherwise stated, all physical radio tests are performed for 25 kHz channel spacing.

9.2 General transceiver tests

9.2.1 Transceiver protection test

9.2.1.1 Purpose

This test demonstrates that the transceiver is properly protected against malfunction due to faults in the antenna system. This shall be the first test applied to the EUT.

9.2.1.2 Method of measurement

While the transmitter is transmitting at the highest output power, the antenna port shall first be short-circuited and then open-circuited, in each case for a period of 5 min.

The EUT shall transmit 225 single slot messages evenly spread across the 5 min period during the short-circuit condition and the open-circuit condition.

A method for transmitting these messages should be provided by the manufacturer.

9.2.1.3 Required results

The proof that the transceiver is protected against malfunctions at the antenna terminal is substantiated by the ability to pass the remainder of the tests in this clause.

9.2.2 Transmitter shutdown procedure

9.2.2.1 Purpose

This verifies that an automatic transmitter hardware shutdown procedure is implemented.

9.2.2.2 Method of measurement

Check manufacturer's documentation on transmitter shutdown procedure.

9.2.2.3 Required result

Verify that a transmitter shutdown procedure, independent of the operating software, is provided.

9.3 TDMA transmitter

9.3.1 General

Unless otherwise stated, all transmitter tests are performed at the highest power setting.

9.3.2 Frequency error

9.3.2.1 Purpose

The frequency error of the transmitter is the difference between the measured carrier frequency in the absence of modulation and its required frequency.

9.3.2.2 Method of measurement

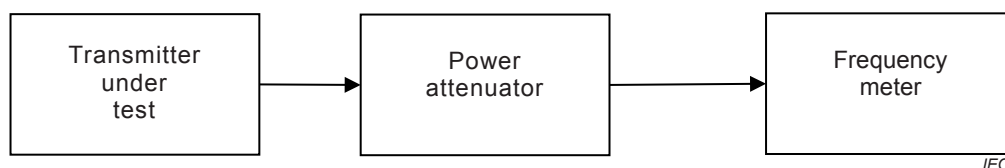

Figure 9 – Measurement arrangement for frequency error

The measurement procedure shall be as follows:

- the equipment shall be connected as illustrated in Figure 9;
- the carrier frequency shall be measured in the absence of modulation;
- the measurement shall be made under normal test conditions and extreme test conditions;
- the test shall be performed at 156,025 MHz and 162,025 MHz.

9.3.2.3 Required results

The frequency error shall not exceed $\pm 0,5$ kHz, under normal test conditions and ± 1 kHz under extreme test conditions.

9.3.3 Carrier power

9.3.3.1 Purpose

The transmitter carrier power conducted (P_C) is the mean power delivered to a nominal 50Ω load during a radio frequency cycle. The rated nominal high power setting shall be 12,5 W and the rated nominal low power setting shall be 1 W. If there is a requirement for different nominal power settings, the carrier power accuracy shall be tested at all settings.

9.3.3.2 Method of measurement

The measurement procedure shall be as follows:

- the equipment shall be connected as illustrated in Figure 10;
- the carrier power shall be measured in the absence of modulation;
- the measurement shall be made under normal test conditions and extreme test conditions;
- the test shall be performed at 156,025 MHz and 162,025 MHz;
- the carrier power accuracy shall be tested at all settings.

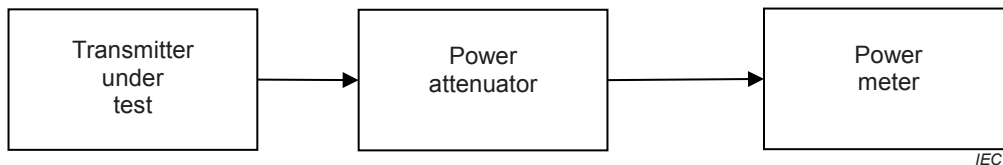

Figure 10 – Measurement arrangement for carrier power

9.3.3.3 Required results

P_C shall be within $\pm 1,5$ dB of the rated carrier power conducted.

P_C under extreme test conditions shall be within ± 3 dB of the rated carrier power conducted.

9.3.4 Modulation spectrum slotted transmission

9.3.4.1 Purpose

This test is to ensure that the modulation sidebands produced by the specified test patterns fall within the allowable masks.

9.3.4.2 Method of measurement

The measurement procedure shall be as follows:

- the EUT shall be connected to a spectrum analyser;
- the test shall be carried out using slotted transmission of test signal number 1;
- a minimum resolution bandwidth of 300 Hz and video bandwidth of 3 kHz and positive peak detection (maximum hold) shall be used for this measurement;
- a sufficient number of sweeps and transmission packets shall be measured to ensure that the emission profile is developed;
- repeat steps a) through d) using test signal number 2;
- tests shall be performed at 156,025 MHz and 162,025 MHz.

9.3.4.3 Required results

The modulation spectrum shall be within the mask detailed in Figure 3.

9.3.5 Transmitter test sequence and modulation accuracy verification

9.3.5.1 Purpose

The test is to verify that the training sequence is a 0101 pattern of 24 bit and starts with a 0. The peak frequency deviation is derived from the baseband signal to verify modulation accuracy.

9.3.5.2 Method of measurement

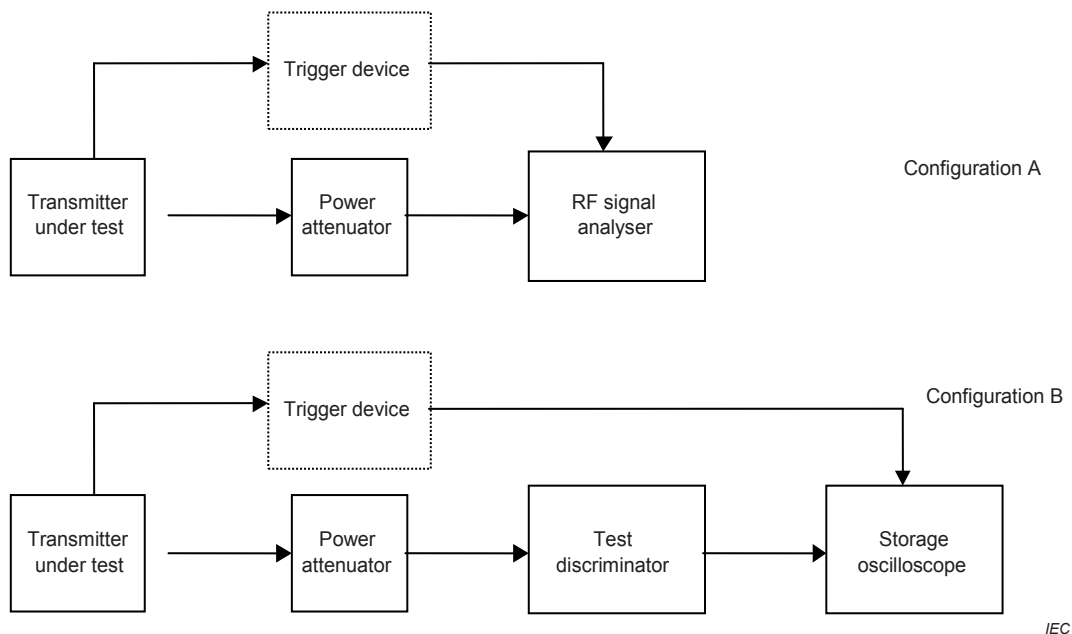

Figure 11 – Measurement arrangement for modulation accuracy

The measurement procedure shall be as follows:

- the equipment shall be connected in either configuration A or configuration B as shown in Figure 11;
- the trigger device is optional if the equipment is capable of synchronising to the transmitted bursts;
- the transmitter shall be tuned to 156,025 MHz;
- the transmitter shall be modulated with a continuous test signal number 1;
- the deviation from the carrier frequency shall be measured as a function of time;
- repeat steps a) through e) with test signal number 2;
- measurement shall be repeated at 162,025 MHz.

9.3.5.3 Required results

For test signal number 1: the training sequence shall start with a '0' bit and, the peak frequency deviation shall be $1\,760\text{ Hz} + 352\text{ Hz} / - 176\text{ Hz}$.

For test signal number 2: The peak frequency deviation shall be $2\,400\text{ Hz} \pm 240\text{ Hz}$.

9.3.6 Transmitter output power versus time function

9.3.6.1 Definition

Transmitter output power versus time function is a combination of the transmitter delay, attack time, release time and transmission duration as defined in Figure 4 and Table 6 where:

- a) transmitter delay time ($T_A - T_0$) is the time between the start of the slot and the moment when the transmit power exceeds -50 dB of the steady-state power (P_{SS});
- b) transmitter attack time ($T_{B2} - T_A$) is the time between the transmit power exceeding -50 dBc and the moment when the transmit power maintains a level within $+1,5$ dB -1 dB from P_{SS} ;
- c) transmitter release time ($T_F - T_E$) is the time between the end flag being transmitted and the moment when the transmitter output power has reduced to a level 50 dB below P_{SS} and remains below this level thereafter;
- d) transmission duration ($T_F - T_A$) is the time from when power exceeds -50 dBc to when the power returns to and stays below -50 dBc.

9.3.6.2 Method of measurement

The measurement procedure shall be as follows:

- a) the measurement shall be carried out by transmitting test signal number 2 (note that this test signal generates one additional stuffing bit within its CRC portion);
- b) the EUT shall be connected to a spectrum analyser. A resolution bandwidth of 1 MHz, video bandwidth of 1 MHz and a sample detector shall be used for this measurement. The analyser shall be in zero-span mode for this measurement;
- c) for the purposes of this test, the EUT shall be equipped with a test signal (SYNC) indicating the start of each time period that it intends to transmit into. This will be used as a trigger source for the spectrum analyser. The SYNC signal shall be aligned to the nominal start time (T_0) of the transmission time period;
- d) tests shall be performed on the lowest operating frequency on which the EUT can transmit according the manufacturers specification and AIS2 ($162,025$ MHz).

9.3.6.3 Required result

The transmitter power shall remain within the mask shown in Figure 4 and associated timings given in Table 6.

9.3.7 Intermodulation attenuation

9.3.7.1 Purpose

The intermodulation attenuation is a measure of the capability of a transmitter to inhibit the generation of signals caused by the presence of the carrier and an interfering signal entering the transmitter via its antenna.

9.3.7.2 Method of measurement

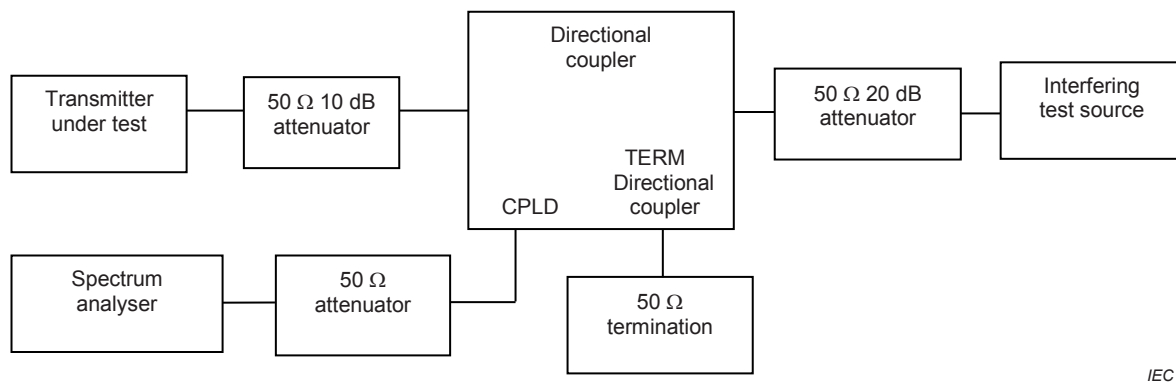

IEC

Figure 12 – Measurement arrangement for intermodulation attenuation

The measurement arrangement shown in Figure 12 shall be used.

- a) The transmitter shall be connected to a 50 Ω 10 dB power attenuator and via a (directional) coupler to a spectrum analyser. An additional attenuator may be required between the directional coupler and the spectrum analyser to avoid overloading.
- b) In order to reduce the influence of mismatch errors, it is important that the 10 dB power attenuator is coupled to the transmitter under test with the shortest possible connection.
- c) The interfering test signal source shall be either a transmitter providing the same power output as the transmitter under test and be of a similar type, or a signal generator and a linear power amplifier capable of delivering the output power as the transmitter under test and connected via a 50 Ω 20 dB power attenuator to the directional coupler.
- d) The (directional) coupler shall have an insertion loss of less than 1 dB. If a directional coupler is used, it shall have a directivity of at least 20 dB.
- e) The transmitter under test and the test signal source shall be physically separated so that the measurement is not influenced by direct radiation.
- f) The transmitter under test shall be unmodulated and the spectrum analyser adjusted to a span of 500 kHz. The transmitter under test shall be set to continuous transmission mode or to the fastest update rate which is available.
- g) The interfering test signal source shall be unmodulated and its frequency shall be within 50 kHz to 100 kHz above the frequency of the transmitter under test. The frequency shall be chosen in such a way that the intermodulation components to be measured do not coincide with other spurious components.
- h) The power output of the interfering test signal source shall be adjusted to the carrier power level of the transmitter under test.
- i) The ratio of the largest third order intermodulation component with respect to the carrier shall be measured on the spectrum analyser and recorded.
- j) This measurement shall be repeated with the interfering test signal source at a frequency within 50 kHz to 100 kHz below the frequency of the transmitter under test.
- k) The intermodulation attenuation of the equipment under test shall be expressed as the lower of the two values recorded in i) and j).

9.3.7.3 Required results

The intermodulation ratio shall be not less than 40 dB.

9.4 TDMA receivers

9.4.1 Sensitivity

9.4.1.1 Purpose

The maximum usable sensitivity (data or messages, conducted) is the minimum signal level at the receiver input, produced by a carrier at the specified frequency of the receiver, modulated with the specified test signal, which will, without interference, produce a data signal with a specified packet error rate (PER) after demodulation. If there is a requirement for sensitivity requirements below -107 dBm, the EUT shall be tested at this stated sensitivity level.

9.4.1.2 Method of measurement

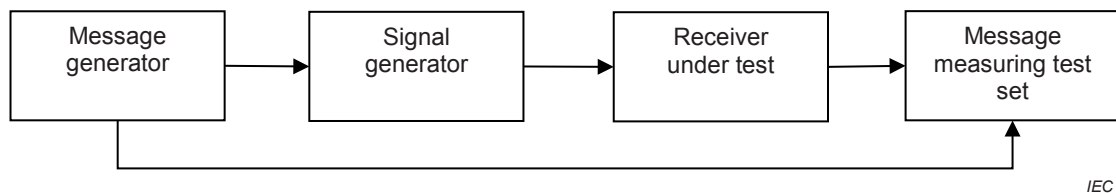

Figure 13 – Measurement arrangement for sensitivity

The measurement procedure shall be as follows:

- a) the equipment shall be connected as illustrated in Figure 13;
- b) the signal generator shall be set to -107 dBm or declared sensitivity level;
- c) use test signal number 3;
- d) the test shall be performed at 156,025 MHz and 162,025 MHz;
- e) a minimum of 200 packets shall be transmitted during the test;
- f) repeat the test under extreme conditions with the signal generator level set to -101 dBm.

9.4.1.3 Required results

A minimum PER of 20 % is required.

9.4.2 Error behaviour at high input levels

9.4.2.1 Purpose

The error behaviour (performance) at high input levels is defined in the same manner as for the measurement of the maximum usable sensitivity when the level of the wanted signal is 100 dB above the maximum usable sensitivity.

9.4.2.2 Method of measurement

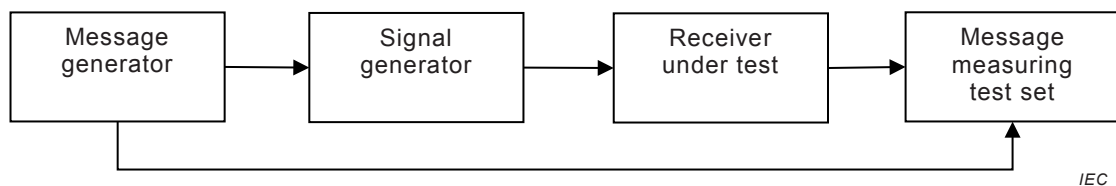

Figure 14 – Measurement arrangement for error behaviour

The measurement procedure shall be as follows:

- a) the equipment shall be connected as illustrated in Figure 14;

- b) an input signal set to 161,975 MHz, modulated with test signal number 3 shall be applied to the receiver;
- c) the level of the input signal shall be adjusted to -77 dBm;
- d) 200 packets shall be transmitted and the PER shall be calculated;
- e) the measurement shall be repeated with the input signal at -7 dBm.

9.4.2.3 Required results

The PER shall not exceed 1 % in either case.

9.4.3 Co-channel rejection

9.4.3.1 Purpose

The co-channel rejection is a measure of the capability of the receiver to receive a wanted modulated signal without exceeding a given degradation due to the presence of an unwanted modulated signal, both signals being at the specified frequency of the receiver.

9.4.3.2 Method of measurement

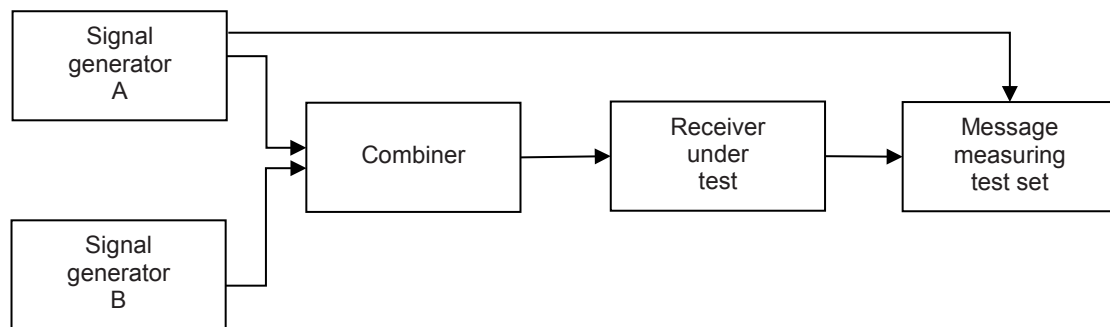

IEC

Figure 15 – Measurement arrangement for co-channel rejection

The measurement procedure shall be as follows:

- a) two generators A and B, shall be connected to the receiver via a combining network as shown in Figure 15;
- b) the wanted signal, provided by signal generator A, shall be at the specified frequency of the receiver and shall be modulated to generate test signal number 3;
- c) the unwanted signal, provided by generator B, shall also be at the specified frequency of the receiver. Generator B shall be frequency modulated with a 400 Hz sine wave giving a deviation of ± 3 kHz;
- d) the level of the wanted signal from generator A shall be adjusted to -104 dBm;
- e) the level of the unwanted signal from generator B shall be adjusted to -114 dBm;
- f) the message measuring test set shall be monitored and the packet error rate observed over 200 transmissions;
- g) the test shall be carried out at a specified frequency of 156,025 MHz and 162,025 MHz.

9.4.3.3 Required result

The PER shall not exceed 20 %.

9.4.4 Adjacent channel selectivity

9.4.4.1 Purpose

The adjacent channel selectivity is a measure of the capability of the receiver to receive a wanted modulated signal without exceeding a given degradation due to the presence of an unwanted signal which differs in frequency from the wanted signal by an amount equal to the adjacent channel separation for which the equipment is intended.

9.4.4.2 Method of measurement

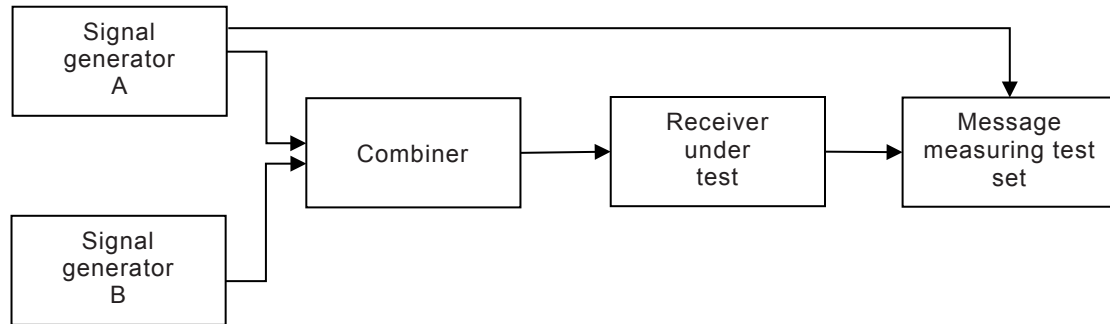

IEC

Figure 16 – Measurement arrangement for adjacent channel selectivity

The measurement procedure shall be as follows:

- two generators A and B, shall be connected to the receiver via a combining network as shown in Figure 16;
- the wanted signal, provided by signal generator A, shall initially be at 156,025 MHz and be modulated to generate test signal number 3;
- the unwanted signal, provided by generator B, shall be frequency modulated with a 400 Hz sine wave giving a deviation of ± 3 kHz. Generator B shall be at a frequency 25 kHz above that of the wanted signal;
- the level of the wanted signal from generator A shall be adjusted to a level of -104 dBm;
- the level of the unwanted signal from generator B shall be adjusted to -34 dBm;
- the message measuring test set shall be monitored and the PER observed over 200 transmissions;
- repeat the above measurement with the unwanted signal 25 kHz below the wanted signal;
- repeat the whole of test steps a) to g) at 162,025 MHz.

9.4.4.3 Required results

The PER shall not exceed 20 %.

9.4.5 Spurious response rejection

9.4.5.1 Purpose

The spurious response rejection is a measure of the capability of the receiver to receive a wanted modulated signal without exceeding a given degradation due to the presence of an unwanted modulated signal at any other frequency, at which a response is obtained.

9.4.5.2 Manufacturers' declarations

The manufacturer shall declare the following in order to calculate the "limited frequency range" over which the initial part of the test will be performed:

- a) list of intermediate frequencies (IF_1, IF_2, \dots, IF_N) in Hz;
- b) switching range of the receiver (sr);

NOTE 1 Switching range corresponds to the frequency range over which the receiver can be tuned.

- c) frequency of the local oscillator at 162,025 MHz (AIS2) and at the lowest TDMA channel (f_{LOH}, f_{LOL}).

NOTE 2 Examples of local oscillators are VCO, crystal, sampling clock, BFO, numerically controlled oscillator etc. depending on the design of the equipment.

9.4.5.3 Introduction to the method of measurement

The initial evaluation of the EUT shall be performed over the limited frequency range and shall then be performed at the frequencies identified from this test and at “specific frequencies of interest” (as defined below).

To determine the frequencies at which spurious responses can occur, the following calculations shall be made.

9.4.5.4 Calculation of the limited frequency range

The limits of the limited frequency range (LFR_{HI} to LFR_{LO}) are determined from the following calculations:

$$LFR_{HI} = f_{LOH} + (IF_1 + IF_2 + \dots + IF_N + sr/2)$$

$$LFR_{LO} = f_{LOL} - (IF_1 + IF_2 + \dots + IF_N + sr/2)$$

The calculation of specific frequencies of interest (SFI) outside the limited frequency range is given below.

These are determined by the following calculations:

$$SFI_1 = (K \times f_{LOH}) + IF_1$$

$$SFI_2 = (K \times f_{LOL}) - IF_1$$

where K is an integer from 2 to 4.

9.4.5.5 Method of measurement over the limited frequency range

Two methods are available for the measurements over the limited frequency range, one based on SINAD measurements and the other based on PER measurements. Either method may be used, but in each case shall be followed by the method of measurement at identified frequencies.

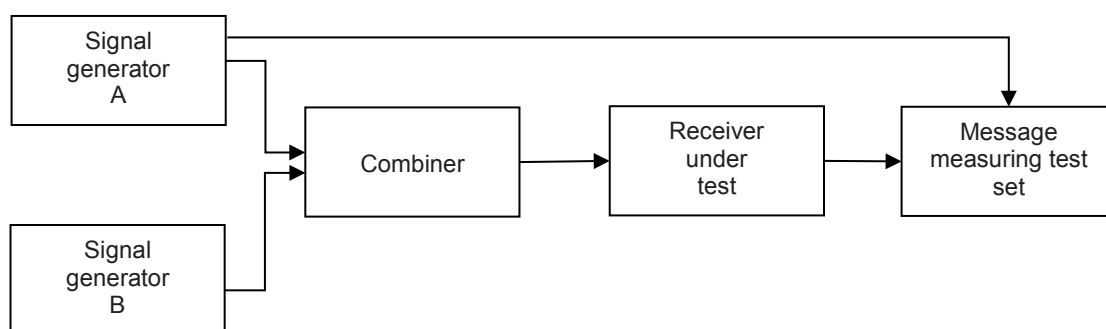

IEC

Figure 17 – PER/BER or SINAD measuring equipment

9.4.5.6 Method of search over the "limited frequency range" using SINAD measurement

The measurement arrangement shown in Figure 17 shall be used.

- a) Two generators A and B shall be connected to the receiver via a combining network.
- b) The wanted signal, provided by generator A, shall be at 162,025 MHz and shall be modulated with a 1 kHz sine wave at $\pm 2,4$ kHz deviation.
- c) The unwanted signal, provided by generator B, shall be frequency modulated with a 400 Hz sine wave giving a deviation of ± 3 kHz.
- d) Initially, generator B (unwanted) shall be switched off (maintaining the output impedance).
- e) The signal level from generator A (wanted) shall be adjusted to -101 dBm at the receiver.
- f) The SINAD value shall be noted (and shall be greater than 14 dB).
- g) Signal generator B shall be switched on and adjusted to -27 dBm at the receiver.
- h) The frequency of the unwanted signal shall be varied in steps of 5 kHz over the Limited Frequency Range (from LFR_{LO} to LFR_{HI}).
- i) The frequency of any spurious response detected (by an decrease in SINAD of 3 dB or more) during the search shall be recorded for use in the next measurement.
- j) Repeat the test using the lowest frequency.

9.4.5.7 Method of search over the limited frequency range using PER or BER measurement

The measurement arrangement shown in Figure 17 shall be used.

- a) Two generators A and B, shall be connected to the receiver via a combining network.
- b) The wanted signal, provided by generator A, shall be at 162,025 MHz and shall be modulated to generate test signal number 3.
- c) The unwanted signal, provided by generator B, shall be frequency modulated with a 400 Hz sine wave giving a deviation of ± 3 kHz.
- d) Initially, generator B (unwanted) shall be switched off (maintaining the output impedance).
- e) The signal level from generator A (wanted) shall be adjusted to -101 dBm at the receiver.
- f) The PER or BER shall be noted.
- g) Signal generator B shall be switched on and adjusted to -27 dBm at the receiver.
- h) The frequency of the unwanted signal shall be varied in steps of 5 kHz over the limited frequency range (from LFR_{LO} to LFR_{HI}).
- i) The frequency of any spurious response detected (by an increase in either PER or BER) during the search shall be recorded for use in the next measurements. In the case where operation using a continuous packet stream is not possible a similar method may be used.
- j) Repeat the test using the lowest frequency.

9.4.5.8 Method of measurement (at identified frequencies)

The measurement arrangement shown in Figure 17 shall be used.

- a) Two generators A and B, shall be connected to the receiver via a combining network.
- b) The wanted signal, provided by generator A, shall be at the high and low channels used for the calculation of SFI_1 and SFI_2 and shall be modulated to generate test signal number 3.
- c) The unwanted signal, provided by generator B, shall be frequency modulated with a 400 Hz sine wave giving a deviation of ± 3 kHz. Generator B shall be at the frequency of that spurious response being considered.
- d) Initially, generator B (unwanted) shall be switched off (maintaining the output impedance).
- e) The signal level from generator A (wanted) shall be adjusted -101 dBm at the receiver.

- f) Generator B shall be switched on, and the level of the unwanted signal set to -31 dBm.
- g) For each frequency noted during the tests over the limited frequency range and the Specific Frequencies of Interest (SFI_1 and SFI_2), transmit 200 packets to the EUT and note the PER.

9.4.5.9 Required results

At any frequency separated from the specified frequency of the receiver by two channels or more, the PER shall not exceed 20 %.

9.4.6 Intermodulation response rejection

9.4.6.1 Purpose

The intermodulation response rejection is the capability of the receiver to receive a wanted modulated signal, without exceeding a given degradation due to the presence of two close-spaced unwanted signals with a specific frequency relationship to the wanted signal frequency.

9.4.6.2 Method of test

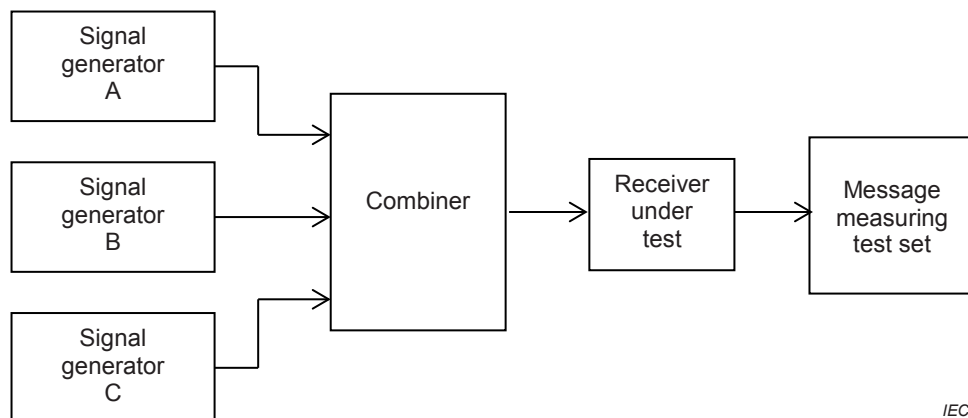

Figure 18 – Measurement arrangement for inter-modulation

The measurement procedure shall be as follows:

- a) three signal generators shall be connected to the receiver via a combining network as shown in Figure 18;
- b) the wanted signal, provided by signal generator A, shall be at the specified frequency of the receiver and shall be modulated to generate test signal number 3;
- c) the unwanted signal from generator B shall be unmodulated;
- d) the unwanted signal from generator C shall be frequency modulated with a 400 Hz sine wave at a deviation of ± 3 kHz;
- e) the signal level from generator A (wanted) shall be set for -101 dBm at the receiver input;
- f) the signal level from generators B and C shall be set for -27 dBm at the receiver input;
- g) the frequencies of generators A, B, and C shall be set as per test number 1 of Table 18;
- h) the message measuring test set shall be monitored and the PER observed over 200 transmissions;
- i) repeat the measurement with frequencies set as per test number 2 of Table 18.

Table 18 – Frequencies for inter-modulation tests

Test number	Generator A Wanted AIS signal	Generator B Unmodulated ± 500 kHz	Generator C Modulated $\pm 1\ 000$ kHz
1	162,025 MHz	161,525 MHz	161,025 MHz
2	156,025 MHz	156,525 MHz	157,025 MHz

9.4.6.3 Required results

The PER shall not exceed 20 %.

9.4.7 Blocking or desensitisation

9.4.7.1 Purpose

Blocking is a measure of the capability of the receiver to receive a wanted modulated signal without exceeding a given degradation due to the presence of an unwanted input signal at any frequency other than those of the spurious responses or the adjacent channels.

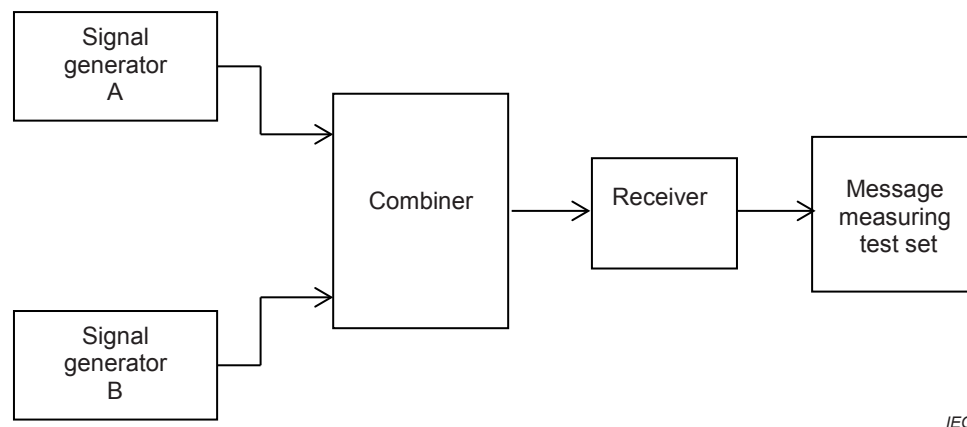

IEC

Figure 19 – Measurement arrangement for blocking or de-sensitisation

9.4.7.2 Method of measurement

The measurement procedure shall be as follows:

- two generators A and B, shall be connected to the receiver via a combining network as shown in Figure 19;
- the wanted signal, provided by signal generator A, shall be initially at 156,025 MHz and be modulated to generate test signal number 3;
- the unwanted signal from generator B shall be unmodulated and tuned to 161,75 MHz. Initially, signal generator B (unwanted signal) shall be switched off (maintaining the output impedance). The level of the wanted signal from generator A shall be adjusted to -101 dBm at the receiver input;
- generator B shall then be switched on, and the level of the unwanted signal set to -15 dBm;
- 200 packets shall be transmitted and the PER recorded;
- repeat the test steps a) to e) with the wanted signal generator tuned to 162,025 MHz and the unwanted signal generator tuned to 156,3 MHz.

9.4.7.3 Required results

The PER shall not exceed 20 %.

9.5 Conducted spurious emissions at the antenna

9.5.1 Spurious emissions from the receiver

9.5.1.1 Purpose

Conducted spurious emissions to the antenna are any RF emissions generated in the receiver and conveyed to the antenna terminal.

9.5.1.2 Method of measurement

Conducted spurious emissions shall be measured as the power level of any frequency component to the antenna terminals of the receiver. The receiver antenna terminals are connected to a spectrum analyser or selective voltmeter having an input impedance of 50 Ω and the receiver is switched on.

The measurement shall extend over the frequency range 9 kHz to 4 GHz.

9.5.1.3 Required results

The power of any spurious emission in the specified range at the antenna terminal shall not exceed –57 dBm in the frequency range 9 kHz to 1 GHz and –47 dBm in the frequency range 1 GHz to 4 GHz.

9.5.2 Spurious emissions from the transmitter

9.5.2.1 Purpose

Spurious emissions are emissions at frequencies other than those of the carrier and sidebands associated with normal modulation.

9.5.2.2 Method of measurement

Conducted spurious emissions shall be measured with the unmodulated transmitter connected to the artificial antenna. The measurement shall be made over a frequency range from 9 kHz to 2 GHz, excluding the channel on which the transmitter is operating and its adjacent channels.

9.5.2.3 Required results

The power of any spurious emission at any frequency shall not exceed –36 dBm in the frequency range 9 kHz to 1 GHz and –30 dBm in the frequency range 1 GHz to 4 GHz.

10 Functional tests for Base Station

10.1 Pre-set-up

10.1.1 Basic initialisation

This basic initialisation has to be performed at the beginning of testing. The set-up can be combined with 10.2.1.

NOTE The sentences provided in the pre-set-up condition and throughout this test clause contain data fields as examples only. The “*”, checksum and <CR><LF> which have to be added to the end of each sentence are not shown in these examples to make the examples easier to read.

For all tests the pre-set-up conditions are:

- a) configure the Unique identifier and the MMSI of the base station to known values. Query the EUT to obtain the current unique identifier and MMSI. The received values are used to provide a SID sentence to set the unique identifier and MMSI to a known value;

\$xxABQ,SID

\$xxSID,<old UI>,<new UI>,<old MMSI>,<new MMSI>,C

- b) set the following parameters to valid appropriate values using BCL and BCG sentences:

- BCL sentence (Base station Configuration, Location Command)
 - 1) position source to surveyed,
 - 2) LAT/LON position to a known location,
 - 3) position accuracy to high,
 - 4) Base Station name to an appropriate value.
- BCG sentence (Base Station configuration, General Command)
 - 5) channels to 2087 and 2088, or two appropriate test channels,
 - 6) transmitter power to high,
 - 7) messages retries to three,
 - 8) repeat indicator to zero,
 - 9) RATDMA control to 0 = off,
 - 10) UTC source to I = internal UTC source,
 - 11) ADS interval to 60 s,
 - 12) Assigned talker ID to AB.

10.1.2 Pre-setup of dependent base station

This setup has to be applied at the beginning of each dependent mode test to start the test in a defined state.

- a) Set the EUT to a normal operation mode with the following settings, using the BCG sentence:

- RATDMA disabled (0);
- internal UTC source (I), UTC available;
- both transmitters enabled;
- AIS channels set to 2087 and 2088 or appropriate test channel.

- b) Disable all autonomous transmissions using an ECB sentence for each Message type 4, 17, 20, 22, 23 and 4 CBR sentences to disable all Message 26 transmissions.

Example: \$xxECB,<UI>,<Message type>,0,-1,,,0,-1,,,C

- c) Disable all optional VDL information using the SPO sentence.

Example: \$xxSPO,UI,N,0,0,0,0,0,0,0,0,0,0,0,0,,C

- d) Clear all FATDMA reservations using 20 DLM sentences.

Example:\$xxDLM,<Reservation no (0...9)>,A,C,,,,C,,,,C,,,,C,,,,C

\$xxDLM,□Reservation no (0...9)□B,C,,,,C,,,,C,,,,C,,,,C

- e) Clear all area settings using 8 ACA sentences with the “in-use” flag set to 0.

10.1.3 Pre-setup for independent mode

This setup has to be applied at the beginning of each independent mode test to start the test in a defined state. It is based on the dependent mode setup. First the dependent setup has to be applied to the EUT. Then the following setup has to be applied:

- a) apply slot reservations according to the following DLM sentence to the EUT. There are slot reservations for the own transmission of Message 20 and 4 and 2 slots every 2 s on each channel for other purposes:

\$xxDLM,0,A,L,4,1,7,250,L,0,1,7,0,L,10,2,7,75,,,,,C

\$xxDLM,0,B,L,129,1,7,250,L,6,1,7,0,L,20,2,7,75,,,,,C;

- b) Activate the transmission of Message 4 every 10s and Message 20 once per frame on both channels according to the following ECB sentence:

\$xxECB,<UI>,4,0,4,750,,0,379,750,,C

\$xxECB,<UI>,20,0,0,0,,0,6,0,,C

10.2 Normal operation

10.2.1 Base Station configuration and services

10.2.1.1 Base Station configuration

10.2.1.1.1 Purpose

The purpose of this test is to verify that the Base Station can be configured with an MMSI and unique identifier. This test verifies the EUT's correct response to these two SID data fields.

10.2.1.1.2 Method of measurement

The measurement procedure shall be as follows:

- a) Apply the following SID sentence using an incorrect unique identifier:

\$xxSID, <incorrect UI>,<new UI>,<old MMSI>,<new MMSI>,C

Query the EUT for the SID sentence to get the Unique Identifier and the MMSI;

- b) Apply the following SID sentence using the correct unique identifier:

\$xxSID, <old UI>,<new UI>,<old MMSI>,<new MMSI>,C

Query the EUT for the SID sentence.

10.2.1.1.3 Required results

Confirm that:

- a) the content of the SID sentence and that the correct MMSI and unique identifier has been retained;
- b) the content of the SID sentence and that the new MMSI and unique identifier has been configured.

10.2.1.2 Base Station report information content and reporting rate

10.2.1.2.1 Purpose

This test verifies the basic functionality of a Base Station. This test will verify the "pre-set-up condition" used in subsequent testing.

10.2.1.2.2 Method of measurement

The measurement procedure shall be as follows:

- a) set up standard test environment and apply the dependent mode pre-set-up conditions;
- b) apply a TSA sentence and a VDM sentence with encapsulated Message 4 to the EUT;

\$xxTSA,<UI>,9,A,<HHMM>,1050,2

!xxVDM,1,1,9,A,40C4qnh00041?G1RMfL0tJi004P4,0

- c) apply the following BBM sentence to the EUT;
!xxBBM,1,1,0,0,14,D5CDP=5CC175,0

The following tests are required for a Base Station operated as an independent unit.

- d) apply the independent mode setup to the EUT;
e) apply a BCL sentence with Message 27 control field set to 1;
f) apply the following SPO sentence to the EUT.
\$xxSPO,<UI>,A,1,1,1,,1,,1,1,1,1,C

10.2.1.2.3 Required results

Confirm that:

- a) the dependent mode setup has been correctly set;
b) the appropriate TFR sentence is output on the PI. Confirm that the EUT is transmitting Message 4 in the assigned slot and channel. Confirm that the Message 4 contains the same data as defined by the VDM sentence. Confirm that the appropriate VDO sentence is output on the PI when a message is transmitted;
c) the EUT did not transmit Message 14 and issued an ABK type 2.

The following results are required for a Base Station operated as an independent unit:

- d) the Independent mode setup has been correctly set. Confirm that the EUT is transmitting Message 4 and Message 20 in the assigned slots, interval, and channels as defined in the ECB sentences. Confirm that the content of Message 20 is as defined by the DLM. Confirm that the length of Message 20 is 104 bit. Confirm that the EUT is transmitting Message 4 with an interval of 10 s, alternating transmission channels A and B. Confirm that the content of Message 4 is as defined by the BCL. Confirm that in the content of Message 4 the UTC/date is provided correctly. Confirm that the communications state for Message 4 is implemented correctly. Confirm that the appropriate VDO sentence is output on the PI when a message is transmitted;
e) the Message 27 control setting is stored by evaluation of BCL query response and that the transmission control for long range broadcast message bit is set in the transmitted Message 4;
f) by query for SPO that the SPO settings are correctly stored. Confirm that the VSI sentence contains the associated information according to Table 9 about each VDM or VDO sentence. Confirm that the FSR sentence contains the associated information according to Table 10 about the conditions for the previous frame. Confirm that the values of the RSSI measurement are within the limits defined in Table 7.

10.2.1.3 Retention of Base Station report information content and reporting rate

10.2.1.3.1 Purpose

This test will verify that a Base Station retains all of its configuration settings upon restart. There are two methods of restart, a physical restart of the Base Station and a restart using the RST sentence. This test will verify that the Base Station retains its last configuration after these restarts. The test will also verify that the Base Station sets its configuration to “undefined” after reset.

10.2.1.3.2 Method of measurement

Set up standard test environment and operate the EUT as defined in the dependent mode pre-set-up conditions.

- a) Remove power from the EUT for 2 s and then re-apply power to the EUT.
b) Restart the EUT using the following RST sentence:

\$xxRST,<UI>,1,,C

The following tests are required for a Base Station operated as an independent unit.

- c) Apply the independent mode set-up to the EUT.
- d) Remove power from the EUT for 2 s and then re-apply power to the EUT.
- e) Restart the EUT using the following RST sentence.

\$xxRST,<UI>,1,,C

- f) Reset the EUT using the following RST sentence.

\$xxRST,<UI>,2,,C

10.2.1.3.3 Required results

Confirm that:

- a) the dependent mode setup was retained correctly, as defined by the pre-set-up conditions, by the EUT using query for the sentences used for the set-up. Confirm that the EUT is receiving position reports on both A and B channels from 5 test targets. These results shall occur within 2 min;
- b) the dependent mode setup was retained correctly, as defined by the pre-set-up conditions, by the EUT using query for the sentences used for the set-up. Confirm that the EUT is receiving position reports on both A and B channels from 5 test targets. These results shall occur within 2 min.

Note that the following tests are required for a Base Station operated as an independent unit:

- c) the independent mode setup has been correctly set;
- d) independent mode set-up was retained correctly by the EUT using query for the sentences used for the set-up. Confirm that the EUT starts the transmission of Message 4 and 20 at the first schedule transmission time after 2 min;
- e) independent mode set-up was retained correctly by the EUT using query for the sentences used for the set-up. Confirm that the EUT starts the transmission of Message 4 and 20 at the first schedule transmission time after 2 min;
- f) all configuration information is reset to the default values as defined in 6.5. Confirm that the Unique Identifier and the MMSI have not been reset.

10.2.1.4 Configuration and operating parameters

10.2.1.4.1 Purpose

This test will verify that the Base Station configuration can be modified. In addition, it will verify the non-default settings. The operation of the TSA+VDM transmission is verified when operating independently.

10.2.1.4.2 Method of measurement

Set up the standard test environment and operate the EUT as defined in the pre-set-up conditions. Switch the working channels for the 5 test targets to appropriate channels as defined in the new BCG sentence.

- a) Apply BCG and BCL sentences with new, different settings to the EUT with an incorrect Unique Identifier.
- b) Apply BCG and BCL sentences with new, different settings to the EUT with a correct Unique Identifier.
- c) Apply a TSA sentence and a VDM sentence with encapsulated Message 4 to the EUT:

\$xxTSA,<UI>,9,A,<UTC>,1050,2

!xxVDM,1,1,9,A,40C4qnh00041?G1RMfL0tJi004P4,0

Note that the following tests are required for a Base Station operated as an independent unit.

- d) Apply the independent mode set-up to the EUT.
- e) Modify the DLM reservations according to the following examples. The modified values are underlined. The first two entries are shifted by 100 slots. The third entry is left empty (null fields):
- ```
$xxDLM,0,A,L,104,1,7,250,L,100,1,7,0,,,,,,,,,C
$xxDLM,0,B,L,229,1,7,250,L,106,1,7,0,,,,,,,,,C
```
- f) Adapt the transmission slots to the reservations under e) using ECB sentence like the following examples:
- ```
$xxECB,<UI>,4,0,104,750,,0,479,750,,C
$xxECB,<UI>,20,0,100,0,,0,106,0,,C
```
- g) Delete the first two reservations using the following DLM sentence:
- ```
$xxDLM,0,A,C,,,,,C,,,,,,,,,,,,,C
$xxDLM,0,B,C,,,,,C,,,,,,,,,,,,,C
```
- h) Stop the transmission of Message 20 using the following ECB sentences:
- ```
$xxECB,<UI>,20,0,-1,,,0,-1,,,C
```
- i) Stop the transmission of Message 4 using the following ECB sentence:
- ```
$xxECB,<UI>,4,0,-1,,,0,-1,,,C
```
- j) Apply the following BBM and VDM sentences to the EUT:
- ```
!xxBBM,1,1,0,0,14,D5CDP=5CC175,0
!xxVDM,2,1,7,A,502=aEP000000000000ph9u0ThuC:222222222016@j1071C0vSchH88,0
!xxVDM,2,2,7,A,8888888888888888,2
```

10.2.1.4.3 Required results

Confirm that:

- the BCG and BCL sentences were ignored by the EUT using the query sentence for the BCG and BCL sentence;
- BCG and BCL sentences were processed correctly by the EUT using query sentences;
- the appropriate TFR sentence is output on the PI. Confirm that the EUT transmits the Message 4 in the assigned slot and channel. Confirm that the content of Message 4 is as defined by the VDM sentence. Confirm that the appropriate VDO sentence is output on the PI when a message is transmitted;

The following results are required for a Base Station operated as an independent unit.

- the independent mode set-up was correctly stored;
- the DLM sentences were stored correctly using the query sentence for DLM. Confirm the third entry has not been modified;
- the ECB sentences were received correctly using the query sentence for ECB. Confirm that the EUT is transmitting Message 4 and Message 20 in the assigned slots, interval and channel as defined in the ECB sentence. Confirm that the appropriate VDO sentence is output on the PI when a message is transmitted. Confirm that the content of Message 20 is according to the settings of e);
- the DLM sentences were received correctly using the query sentence for DLM. Check that the first two entries are deleted and the third entry is retained;
- the ECB sentences were received correctly using the query sentence for ECB. Confirm that the Base Station stops transmitting Message 20. Confirm that the EUT is only transmitting Message 4 in the assigned slots as defined in the ECB message;

- i) the ECB sentences were received correctly by the EUT using the query sentence for ECB. Confirm that the Base Station stops transmitting Message 4;
- j) the EUT transmitted Message 14 and issued an ABK type 3. Confirm that the EUT transmitted Message 5 and issued a TFR sentence for Message 5.

10.2.1.5 FATDMA configuration

10.2.1.5.1 Purpose

This test will verify the ability of the Base Station to configure all twenty FATDMA data set definitions (ten per channel).

10.2.1.5.2 Method of measurement

Set up the standard test environment and operate the EUT as defined in the pre-set-up conditions.

The following tests are required for a Base Station operated as an independent unit.

- a) Enable RATDMA using a BCG sentence like:

```
$xxBCG,<UI>,,,,,,,,,1,,,C
```

- b) Apply the following 20 DLM sentences to the EUT:

```
$xxDLM,0,A,L,0004,1,7,0250,L,0000,1,7,0000,L,0010,1,7,0450,L,0070,2,7,0075,C
```

```
$xxDLM,0,B,L,0129,1,7,0250,L,0006,1,7,0000,L,0012,1,7,0450,L,0050,2,7,0075,C
```

```
$xxDLM,1,A,L,0100,1,7,0000,L,0101,2,6,0000,L,0103,3,5,0000,L,0106,5,4,0000,C
```

```
$xxDLM,1,B,L,0300,1,7,0000,L,0301,2,6,0000,L,0303,3,5,0000,L,0306,5,4,0000,C
```

```
$xxDLM,2,A,L,0400,1,7,0000,L,0401,2,6,0000,L,0403,3,5,0000,L,0406,5,4,0000,C
```

```
$xxDLM,2,B,L,0600,1,7,0000,L,0601,2,6,0000,L,0603,3,5,0000,L,0606,5,4,0000,C
```

```
$xxDLM,3,A,L,0700,1,7,0000,L,0701,2,6,0000,L,0703,3,5,0000,L,0706,5,4,0000,C
```

```
$xxDLM,3,B,L,0900,1,7,0000,L,0901,2,6,0000,L,0903,3,5,0000,L,0906,5,4,0000,C
```

```
$xxDLM,4,A,L,1100,1,7,0000,L,1101,2,6,0000,L,1103,3,5,0000,L,1106,5,4,0000,C
```

```
$xxDLM,4,B,L,1200,1,7,0000,L,1201,2,7,0000,L,1203,3,7,0000,L,1206,5,7,0000,C
```

```
$xxDLM,5,A,L,1300,1,7,0000,L,1301,2,6,0000,L,1303,3,5,0000,L,1306,5,4,0000,C
```

```
$xxDLM,5,B,L,1500,1,7,0000,L,1501,2,7,0000,L,1503,3,7,0000,L,1506,5,7,0000,C
```

```
$xxDLM,6,A,L,1600,1,7,0000,L,1601,2,7,0000,L,1603,3,7,0000,L,1606,5,7,0000,C
```

```
$xxDLM,6,B,L,1800,1,7,0000,L,1801,2,7,0000,L,1803,3,7,0000,L,1806,5,7,0000,C
```

```
$xxDLM,7,A,L,1900,1,7,0000,L,1901,2,7,0000,L,1903,3,7,0000,L,1906,3,7,0000,C
```

```
$xxDLM,7,B,L,2100,1,7,0000,L,2101,2,7,0000,L,2103,3,7,0000,L,2106,5,7,0000,C
```

```
$xxDLM,8,A,L,2150,1,7,0000,L,2151,2,7,0000,L,2153,3,7,0000,L,2156,5,7,0000,C
```

```
$xxDLM,8,B,L,2200,1,7,0000,L,2201,2,7,0000,L,2203,3,7,0000,L,2206,5,7,0000,C
```

```
$xxDLM,9,A,L,1700,1,7,0000,L,1701,2,7,0000,L,1703,3,7,0000,L,1706,5,7,0000,C
```

```
$xxDLM,9,B,L,1750,1,7,0000,L,1751,2,7,0000,L,1753,3,7,0000,L,1756,5,7,0000,C
```

- c) Activate the transmission of Message 4 and 20 using the following ECB sentences:

```
$xxECB,<UI>,4,0,104,750,,0,379,750,,C
```

```
$xxECB,<UI>,20,0,10,450,,0,12,450,,C
```

- d) Clear all FATDMA reservations using 20 DLM sentences;

Example:

```
$xxDLM,<Reservation no (0...9)>,A,C,,,,,C,,,,,C,,,,,C,,,,,C
```

\$xxDLM,<Reservation no (0...9)>,B,C,,,,,C,,,,,C,,,,,C,,,,,C

- e) Apply the following DLM sentences to the EUT:

\$xxDLM,0,A,L,0004,1,7,0250,L,0010,1,7,0450,R,0005,5,7,0030,R,0015,5,7,0030,C

\$xxDLM,1,A,R,0020,4,7,0030,R,0025,5,7,0030,R,0030,4,7,0030,R,0011,2,7,0030,C

\$xxDLM,0,B,L,0129,1,7,0250,L,0012,1,7,0450,,,,,,,,,C

- f) Apply the following BBM sentences to the EUT:

!xxBBM,1,1,0,0,14,D5CDPC165DIP=5CC1750,0

10.2.1.5.3 Required results

The following results are required for a Base Station operated as an independent unit.

Confirm that:

- the BCG sentences were received correctly by the EUT using the query sentence for the BCG sentence;
- DLM sentences were received correctly by the EUT using the query sentence for the DLM sentence;
- the ECB sentences were received correctly by the EUT using the query sentence for the ECB sentence. Confirm that the appropriate VDO sentence is output on the PI when a Message 20 is transmitted. Confirm that the EUT is transmitting Message 20(s) over the VDL in the specified slots and specified channels with the specified configuration parameters from the DLM and the ECB sentence. Confirm that all the Message 20(s) required by the full set of DLM sentences are transmitted over the VDL within 2 frames in the assigned slots as defined in the ECB sentence;
- DLM sentences were received correctly by the EUT using the query sentence for the DLM sentence. Confirm that the EUT is no longer transmitting any Message 20 over the VDL. Confirm that the EUT continues to transmit Message 4 over the VDL;
- DLM sentences were received correctly by the EUT using the query sentence for DLM sentence;
- the Message 14 is transmitted over the VDL within 4 s using RATMDA in available slots and not using the remotely allocated slots.

10.2.1.6 Channel management

10.2.1.6.1 Purpose

This test will verify that the Base Station will transmit Message 22 according to the configuration.

10.2.1.6.2 Method of measurement

Set up the standard test environment and operate the EUT as defined in the pre-set-up conditions.

The following tests are required for a Base Station operated as an independent unit.

- Apply the independent mode setup to the EUT.
- Apply a channel management area setting using an ACA sentence, and the in-use flag set to 1.
- In addition to the standard independent mode setup reserve slots for the transmission of Message 22 once per frame using the following sentence:
- \$xxDLM,0,A,L,4,1,7,250,L,0,1,7,0,L,10,1,7,75,L,1,1,7,0,C
- \$xxDLM,0,B,L,129,1,7,250,L,6,1,7,0,L,20,1,7,75,L,7,1,7,0,C
- Apply the following ECB sentence to start Message 22 transmissions by the EUT:

- g) \$xxECB,<UI>,22,0,1,0,,0,7,0,,C
- h) Initiate a single transmission of an MMSI addressed Message 22 using an ACM sentence like the following example:
\$xxACM, <MMSI of mobile 1>,<MMSI of mobile 2>,<Ch.A>,0,<Ch.B>,0,0,0,<Tx Channel>,3,C
- i) Apply ACA sentences to the EUT defining seven further regional areas with the in-use flag set to 1.
- j) Cycle power on the EUT.
- k) Apply an ACA sentence for each of the 8 stored area settings, with the same area definition as stored, but the in-use flag set to 0.

10.2.1.6.3 Required results

The following results are required for a Base Station operated as an independent unit.

Confirm that:

- a) the independent mode setup has been correctly set;
- b) the ACA sentence was received correctly by the EUT using the query sentence for the ACA sentence;
- c) the DLM sentence was received correctly by the EUT using the query sentence for the DLM sentence;
- d) the ECB sentence was received correctly by the EUT using the query sentence for the ECB sentence. Confirm that the EUT is transmitting Message 22 over the VDL in the specified slots and specified channels. Confirm the content of the Message 22 is as defined by the ACA message. Confirm that the EUT continues to transmit Messages 4 and 20 as defined. Confirm that the appropriate VDO sentence is output on the PI when a message is transmitted;
- e) the EUT transmits an MMSI addressed Message 22 within the 4 s. Confirm that the content of Message 22 is as defined by the ACM sentence and that the MMSIs have the correct number of bits in Message 22;
- f) the EUT correctly stores the regional operating areas by querying for the ACA configuration. Check that the areas are transmitted sequentially in Message 22;
- g) the EUT's channel management settings are retained and that Message 22 starts transmitting again within 2 min;
- h) the EUT removes the 8 area settings or sets the in-use flag of the stored areas to 0. Confirm that the EUT ceases transmission of the channel management messages.

10.2.1.7 VDM to VDL processing

10.2.1.7.1 Purpose

This test will verify that the Base Station can receive multiple types of VDM inputs and transmit the encapsulated message as required by the message type.

10.2.1.7.2 Method of measurement

Set up the standard test environment and operate the EUT as defined in the dependent mode pre-set-up conditions.

- a) Apply a VDM sentence to the EUT.

The following tests are required for a Base Station operated as an independent unit.

- b) Apply the independent mode setup to the EUT.
- c) Enable RATDMA using a BCG sentence:

\$xxBCG,<UI>,,,,,,,,,1,,,C

- d) Apply VDM sentences with encapsulated Message 1 to 27 and one undefined message to the EUT. Message 15 shall be with and without slot offset. Message 16 shall be with rate assignment and slot assignment.

- e) Apply a VDM of Message 1 like the following VDM sentence with a CommState allocating slots and repeat indicator = 0 to the EUT:

!xxVDM,1,1,,A,15M3NSwP00J6TN>?a0e3Ngv000Sq,0

- f) Disable RATDMA and clear available FATDMA slots. Apply a VDM sentence to the EUT:

\$xxBCG,<UI>,,,,,,,,,0,,,C

\$xxDLM,0,A,L,4,1,7,750,L,0,1,7,0,C,,,,,,,,,C

\$xxDLM,0,B,L,379,1,7,750,L,6,1,7,0,C,,,,,,,,,C

- g) Apply a DLM sentence with one available slot in each frame. Then apply 5 VDM sentences:

\$xxDLM,0,A,L,4,1,7,750,L,0,1,7,0,L,10,1,7,0,,,,,

10.2.1.7.3 Required results

Confirm that:

- a) the EUT generates an appropriate TFR sentence and does NOT transmit the VDM.

The following results are required for a Base Station operated as an independent unit:

- b) the independent mode setup has been correctly set;
- c) the RATDMA flag is set to 1;
- d) the EUT generates an appropriate TFR sentence and transmits each allowable message, allowing up to 4 s between transmissions in available FATDMA or RATDMA slots. Confirm that the information in each transmitted message is complete and correct. Confirm that the appropriate VDO sentence is output on the PI when a message is transmitted. Confirm that VDL Message 4, 11 and 20 VDM sentences are not transmitted. Confirm that only VDL Message 15s without slot offset are transmitted. Confirm that Message 16 with slot assignment is not transmitted. Confirm that the CommState is cleared for messages with a CommState;
- e) the EUT generates an appropriate TFR sentence and transmits the message after correcting CommState and that the repeat indicator is not zero;
- f) the EUT generates an appropriate TFR sentence and does NOT transmit the VDM;
- g) the DLM sentence was received correctly by the EUT using the query sentence for the DLM sentence. Confirm that the EUT transmits the 5 VDM messages, one in each frame.

10.2.1.8 TSA and associated VDM processing

10.2.1.8.1 Purpose

This test will verify that the Base Station can receive a TSA and the associated VDM for all message types, and transmit the encapsulated message in the assigned slot.

10.2.1.8.2 Method of measurement

Set up the standard test environment and operate the EUT as defined in the pre-set-up conditions.

- a) Apply TSA+VDM sentence pair with encapsulated Message 1 to 27 to the EUT.
- b) Apply the following TSA+VDM sentence pair with a CommState allocating slots and repeat indicator = 0 to the EUT:

\$xxTSA,<UI>,9,A,<UTC h+m>,2100,2

!xxVDM,1,1,9,A,15M3NSwP00J6TN?>a0e3Ngv000Sq,0

- c) Apply five TSA and five VDM sentences with encapsulated Message 1 to the EUT assigning the transmission of the five Messages 1s in consecutive slots on the same channel.

\$xxTSA, <UI>,0,A, <UTC h+m>,1001,2

!ABVDM,1,1,0,A,15M3NSwP00J6TN0?>a0iT<Ov>0D01,0

\$xxTSA, <UI>,1,A, <UTC h+m>,1002,2

!ABVDM,1,1,1,A,15M3NSwP00J6TN0?>a0iT<Ov>0D01,0

\$xxTSA, <UI>,2,A, <UTC h+m>,1003,2

!ABVDM,1,1,2,A,15M3NSwP00J6TN0?>a0iT<Ov>0D01,0

\$xxTSA, <UI>,3,A, <UTC h+m>,1004,2

!ABVDM,1,1,3,A,15M3NSwP00J6TN0?>a0iT<Ov>0D01,0

\$xxTSA, <UI>,4,A,<UTC h+m>,1005,2

!ABVDM,1,1,4,A,15M3NSwP00J6TN0?>a0iT<Ov>0D01,0

- d) Apply the TSA+VDM sentence pair with an encapsulated message ID that is undefined, with the correct message structure to the EUT.

\$xxTSA,<UI>,5,A, <UTC h+m>,1005,2

!ABVDM,1,1,5,A,W5M3NSwP00J6TN0?>a0iT<Ov>0D01,0

- e) Apply a TSA sentence and a VDM sentence with encapsulated Message 8, using five slots (168 characters = 1 008 bit).

\$xxTSA,<UI>,6,B, <UTC h+m>,1005,2

!xxVDM,3,1,6,B,8h3OHqh0J00@DHLPT048<@DHLPT048<@DHLPT048<@DHLPT048<@DHLPT048,0

!xxVDM,3,2,6,B,<@DHLPT048<@DHLPT048<@DHLPT048<@DHLPT048<@DHLPT048<@DHLPT048,0

!xxVDM,3,3,6,B,<@DHLPT048<@DHLPT048<@DHLPT048<@DHLPT048<@DHLPT0,0

Apply a TSA sentence and a VDM sentence with encapsulated Message 14 at least 266 ms (10 slot duration) before the scheduled Message 8 using one slot and using the same start slot number on the same channel.

\$xxTSA,<UI>,7,B, <UTC h+m>,1005,2

!xxVDM,1,1,7,B,>h3OHqi@E=@,2

- f) Apply a TSA sentence and a VDM sentence with encapsulated Message 14 using one slot with a UTC time that is invalid to the EUT (e.g. 25 h 61 min).

\$xxTSA,<UI>,8,B,2561,1005,2

!xxVDM,1,1,8,B,>h3OHqi@E=@,2

- g) Apply a TSA sentence and a VDM sentence with encapsulated Message 14 using an invalid slot number to the EUT.

\$xxTSA,<UI>,9,B, <UTC h+m>,2250,2

!xxVDM,1,1,9,B,>h3OHqi@E=@,2

- h) Apply a TSA sentence and a VDM sentence with encapsulated Message 14 using six slots to the EUT (196 characters = 1 176 bit).

\$xxTSA,<UI>,6,B, <UTC h+m>,1005,2

!xxVDM,4,1,6,B,>h3OHqh048<@DHLPT048<@DHLPT048<@DHLPT048<@DHLPT048<@DHLPT048,0

!xxVDM,4,2,6,B,<@DHLPT048<@DHLPT048<@DHLPT048<@DHLPT048<@DHLPT048<@DHLPT048,0

!xxVDM,4,3,6,B,<@DHLPT048<@DHLPT048<@DHLPT048<@DHLPT048<@DHLPT048<
@DHLPT048,0

!xxVDM,4,4,6,B,<@DHLPT048<@DHLPT048,0

- i) Apply the number of TSA+VDM pairs needed to exceed available memory.
- j) Apply a VDM of Message 14 without TSA sentence.
- k) Apply TSA and VDM sentences with encapsulated Message 14 to the EUT assigning the transmission of the Message 14s with the scheduled time before the current time. Apply the same TSA with the priority set to 0 to cancel the transmission.

\$xxTSA,<UI>,0,A, <UTC h+m>,1001,2

!xxVDM,1,1,0,B,>h3OHqi@E=@,2

\$xxTSA,<UI>,,A, <UTC h+m>,1001,0

The following tests are required for a Base Station operated as an independent unit.

- l) Apply a TPC to prohibit the use of slots.

\$xxTPC,<UI>99,A,<hhmmss>,0,1000,5,,,,,E,C

Apply a TSA+VDM of Message 14 that uses the prohibited slots reserved by the TPC.

\$xxTSA,<UI>,7,A, <UTC h+m>,1001,2

!xxVDM,1,1,7,B,>h3OHqi@E=@,2

- m) Apply a TSA+VDM in the same slot, different frame from l).

\$xxTSA,<UI>,7,B, <UTC h+m+1>,1001,2

!xxVDM,1,1,7,B,>h3OHqi@E=@,2

- n) Activate the autonomous transmission of Message 4.

\$xxECB,<UI>,4,0,4,750,,0,379,750,,C

Apply a TSA/Message 8 VDM pair with low priority in conflict with the autonomous Message 4 transmission defined in the ECB.

\$xxTSA,<UI>,7,B, <UTC h+m>,1129,2

!xxVDM,1,1,7,B,8h3OHqh0J7ps?3qv,0

- o) Apply a TSA/Message 8 VDM pair with high priority in conflict with the autonomous Message 4 transmission defined in the ECB.

\$xxTSA,<UI>,7,B, <UTC h+m>,1879,1

!xxVDM,1,1,7,B,8h3OHqh0J7ps?3qv,0

- p) Apply a TPC to reserve slots in conflict with the Message 4 schedule.

\$xxTPC,<UI>1,A,<hhmmss>,0,750,5,,,,,E,C

10.2.1.8.3 Required results

Confirm that:

- a) the appropriate TFR sentences are output on the PI. Confirm that the EUT is transmitting Messages 1 to 27 as required over the VDL in the assigned slots and that the information is complete and correct. Confirm that the appropriate VDO sentences are output on the PI when a message is transmitted;
- b) the appropriate TFR sentence is output on the PI. Confirm that the EUT transmits the message with no data content processing. Confirm that the appropriate VDO sentence is output on the PI when a message is transmitted;
- c) the appropriate TFR sentences are output on the PI. Confirm that the EUT transmits the five Message 1s in the assigned consecutive slots on the same channel and that the information is complete and correct. Confirm that the appropriate VDO sentences are output on the PI when a message is transmitted;

- d) the appropriate TFR sentence is output on the PI. Confirm that the EUT transmits the message with no data content processing. Confirm that the appropriate VDO sentence is output on the PI when a message is transmitted;
- e) the EUT generates a TFR sentence with status 0 for Message 8 on the PI. Confirm that the EUT generates a TFR sentence with status 1 for Message 14 on the PI. Confirm that the EUT transmits only Message 14. Confirm that the appropriate VDO sentence is output on the PI when a message is transmitted;
- f) the EUT generates a TFR sentence with status 10 for Message 14 on the PI. Confirm that the EUT does not transmit Message 14;
- g) the EUT generates a TFR sentence with status 10 for Message 14 on the PI. Confirm that the EUT does not transmit Message 14;
- h) the EUT generates a TFR sentence with status 10 for Message 14 on the PI. Confirm that the EUT does not transmit Message 14;
- i) the EUT generates a TFR sentence with status 3. If it is not possible to exceed the available memory the test is deemed to be passed;
- j) the EUT generates a TFR with status 10 and does not transmit Message 14;
- k) the EUT generates a TFR sentence with status 2 for the original TSA/VDM pair. Confirm that the EUT generates a TFR with status 4 for the second TSA sentence, with priority 0, which cancels the first TSA sentence and that Message 14 is not transmitted.

The following results are required for a Base Station operated as an independent unit:

- l) the EUT generates a TSR sentence with status 0. Confirm that the EUT generates a TFR sentence with status 7 for the TSA/VDM of Message 14 for the prohibited slot;
- m) the EUT generates a TFR sentence with status 0. Confirm that the EUT transmits Message 14;
- n) the ECB PI sentence was received correctly by the EUT and it starts transmission of Message 4. Confirm that the EUT generates a TFR sentence with status 5. Confirm that the EUT does NOT transmit Message 8;
- o) the EUT generates a TFR sentence with status 1. Confirm that the EUT transmits Message 8 replacing the scheduled Message 4;
- p) the EUT generates a TSR sentence with status 1.

10.2.1.9 DGNSS VDM Message 17

10.2.1.9.1 Purpose

This test will verify that the Base Station is capable of handling a VDM with an encapsulated Message 17.

10.2.1.9.2 Method of measurement

The following tests are required for a Base Station operated as an independent unit.

Set up the standard test environment and operate the EUT as defined in the pre-set-up conditions.

- a) Apply the independent mode setup to the EUT.
- b) Define a transmission schedule for Message 17 with a reporting interval of 10 s using an ECB sentence:
\$xxECB,<UI>,17,0,10,750,2,0,85,750,2,C
- c) Apply VDM sentences with encapsulated Message 17 for a period of at least 1 min.
- d) Discontinue the VDM sentences with encapsulated Message 17.
- e) Disable the transmission schedule for Message 17 using an ECB sentence like the following sentence:

\$xxECB,<UI>,17,0,-1,,,0,-1,,,C

- f) Apply VDM sentences with encapsulated Message 17 for a period of at least 1 min.

10.2.1.9.3 Required results

The following results are required for a Base Station operated as an independent unit.

Confirm that:

- the independent mode setup has been correctly set;
- the ECB sentence was received correctly by the EUT using the query sentence for the ECB sentence;
- the EUT is transmitting Message 17 over the VDL in the specified slots, intervals and channels as defined by the ECB. Confirm the content of Message 17 is the most current and as defined by the VDM. Confirm that the appropriate VDO sentence is output on the PI when a message is transmitted;
- the EUT continues transmitting Message 17 over the VDL for 1 min then stops transmission;
- the ECB sentence was received correctly by the EUT using the query sentence for the ECB sentence;
- the EUT transmits Message 17 over the VDL in accordance with the rules for VDM transmissions using the slots reserved by DLM for own use.

10.2.1.10 Assigned mode with Message 16

10.2.1.10.1 Purpose

This test will verify that the Base Station can establish hard and soft slot assignments using Message 16.

10.2.1.10.2 Method of measurement

Set up the standard test environment and operate the EUT as defined in the pre-set-up conditions.

The following tests are required for a Base Station operated as an independent unit.

- Apply the independent mode setup to the EUT.
- Input the following ASN sentence with a slot assignment, start slot 10 and slot increment 5 (interval = 75 slots) for station A and a rate assignment, 1 s reporting interval, for station B to the EUT. Adapt the slot reservation by DLM to the slots used by the slot assigned station.

\$xxDLM,0,A,L,4,1,7,750,L,0,1,7,0,L,10,1,7,150,,,,,C

\$xxDLM,0,B,L,129,1,7,250,L,6,1,7,0,L,85,1,7,150,,,,,C

\$xxASN,<MMSI A>,,10,5,<MMSI B>,600,,0,1,C

- Enable RATDMA and then input a BBM sentence (Message 8) to the EUT.

10.2.1.10.3 Required results

The following results are required for a Base Station operated as an independent unit.

Confirm that:

- the independent mode setup has been correctly set;
- the EUT is transmitting Message 16, within 4 s in an available FATDMA slot, over the appropriate channel on the VDL. Confirm the content of Message 16 is as defined by the

ASN. Confirm that the appropriate VDO sentence is output on the PI when a message is transmitted. Verify that the “Offset” and “Increment” parameters of Message 16 are correctly set according to Table 19;

Table 19 – Calculation of parameters in Message 16

Message 16 parameter	Station A Slot assignment	Station B Rate assignment
Offset	Calculated from actual Tx slot of Message 16 and ASN Start slot assignment	= ASN Soft assigned reporting rate
Increment	= ASN Increment > 0	= ASN Increment = 0

- c) the EUT is transmitting Message 8 within 4 s, not using a FATDMA slot assigned to the mobile station.

10.2.1.11 Group assignment with Message 23

10.2.1.11.1 Purpose

This test will verify that the Base Station can store an AGA setting for each station type and transmit Message 23 according to the AGA settings with a transmission schedule as defined by an ECB setting.

10.2.1.11.2 Method of measurement

Set up the standard test environment and operate the EUT as defined in the pre-set-up conditions.

The following tests are required for a Base Station operated as an independent unit.

- a) Apply the independent mode setup to the EUT
 b) Apply a DLM sentence to reserve slots for transmission of 3 Messages 23 per frame on channel A. Apply an AGA sentence for Message 23 content for each station type from 0-15.

```
$xDLM,0,A,L,4,1,7,250,L,0,1,7,0,L,10,2,7,75,L,45,1,7,750,C
```

```
$xAGA,<UI>,<Station type>,0,NElat,NElong,SWlat,SWlong,0,0,0,C
```

- c) Activate the transmission of 3 Message 23 per frame on channel A in the slots reserved by DLM:

```
$xECB,<UI>,23,1,45,750,,,,,,,,C
```

- d) Apply an AGA sentence for Message 23 content for each station type from 0-15 to delete the setting.

```
$xAGA,<UI>,<Station type>,0,9100.0,N,18100.0,E,9100.0,N,18100.0,E,0,0,0,C
```

10.2.1.11.3 Required results

The following results are required for a Base Station operated as an independent unit.

Confirm that:

- a) the Independent mode setup has been correctly set;
 b) the DLM sentence was received correctly by the EUT using the query sentence for the DLM sentence. Confirm that the AGA sentences for Message 23 were received correctly by the EUT using the query sentence for the AGA sentence. For each station type an AGA sentence with the correct settings has to be output;
 c) the Message 23s are transmitted in the defined slots. Confirm the content of Message 23 is as defined in the AGA sentences. Confirm that the AGA settings are transmitted in

Message 23 one after the other, including the setting for station type 10 for Message 27 transmission control. Confirm in case of station type 10 that Type of Ship and cargo Type, Reporting Interval, Tx/Rx mode and Quiet Time are not added to Message 23. The fields shall be set to default values. The Reporting Interval shall be set to 0;

d) Message 23 is no longer transmitted.

10.2.1.12 Scheduled transmission of Message 24A

10.2.1.12.1 Purpose

This test will verify that the Base Station can be configured to transmit Message 24A to provide the base station name.

10.2.1.12.2 Method of measurement

Set up the standard test environment and operate the EUT as defined in the pre-set-up conditions.

The following tests are required for a Base Station operated as an independent unit.

- a) Apply the independent mode setup to the EUT.
- b) Activate the transmission of Message 24A, reporting interval = 3 min, with a sentence like:
\$xxECB,<UI>,24,1,10,13500,,4,20,13500,,C
- c) Apply an ECB sentence to stop the transmission of Message 24.
\$xxECB,<UI>,24,1,-1 , ,4,-1, ,,C

10.2.1.12.3 Required results

The following results are required for a Base Station operated as an independent unit.

Confirm that:

- a) the independent mode setup has been correctly set;
- b) the EUT is transmitting Message 24A in the assigned slots, interval, and channels as defined in the ECB sentences. Confirm that the content of Message 24A, the base station name, is as defined by the BCL sentence. Confirm that the appropriate VDO sentence is output on the PI when a message is transmitted;
- c) Message 24A is no longer transmitted.

10.2.1.13 Scheduled transmission of Message 26

10.2.1.13.1 Purpose

This test will verify that the Base Station can be configured for up to 4 transmission schedules for Message 26 with different content and transmits Message 26 according to the defined transmission schedules.

10.2.1.13.2 Method of measurement

Set up the standard test environment and operate the EUT as defined in the pre-set-up conditions.

The following tests are required for a Base Station operated as an independent unit.

- a) Apply the independent mode setup to the EUT.
- b) Apply a DLM sentence to reserve slots for transmission of 4 Message 26 schedules. Apply 4 MEB sentences with the content for 4 Message 26.
\$xxDLM,0,A,L,4,1,7,250,L,0,1,7,0,L,10,2,7,75,L,45,1,7,375,C

!xxMEB,1,1,0,A,<MMSI>,26,1,0,0,0,C,<encData1>,0

!xxMEB,1,1,1,A,<MMSI>,26,2,0,0,1,C,<encData2>,0

!xxMEB,1,1,3,A,<MMSI>,26,3,0,<DestMMSI1>,0,C,<encData3>,0

!xxMEB,1,1,4,A,<MMSI>,26,4,0,<DestMMSI2>,1,C,<encData4>,0

c) Activate the transmission of 4 transmission schedules for Message 26.

- One FATDMA transmission schedule with 10 s reporting interval on channel A and B with SOTDMA CommState.

\$xxCBR,<MMSI>,26,1,12,0,45,750,0,12,0,420,750,C

- One FATDMA transmission schedule with 1 min reporting interval on Channel A with SOTDMA CommState.

\$xxCBR,<MMSI>,26,2,12,0,400,2250,0,,, -1,,C

- One FATDMA transmission schedule with 3 min reporting interval on Channel A with ITDMA CommState.

\$xxCBR,<MMSI>,26,3,12,1,1150,6750,0,,, -1,,C

- One RATDMA transmission schedule on channel B, reporting interval 2 min with ITDMA CommState.

\$xxCBR,<MMSI>,26,4,,, -1,,1,12,2,777,4500,C

d) Apply CBR sentences to stop the transmission of Message 26 for all 4 transmission schedules.

\$xxCBR,<MMSI>,26,<MsgIdIndex>,,, -1,,0,,, -1,,C

10.2.1.13.3 Required results

The following results are required for a Base Station operated as an independent unit.

Confirm that:

- a) the Independent mode setup has been correctly set;
- b) the DLM sentence was received correctly by the EUT using the query sentence for the DLM sentence. Confirm that the MEB sentences for Message 26 were received correctly by the EUT using the query sentence for MEB. Confirm that there are 4 MEB output sentences, one for each Message Id index;
- c) the Messages 26 of the FATDMA transmission schedules are transmitted in the defined slots. Confirm that the RATDMA messages are transmitted with the correct transmission interval, with a selection interval of 4 s. Confirm that the content of Message 26 is as defined in the MEB sentences. Confirm that the CommState is correct, with the appropriate CommState type (SOTDMA, ITDMA);
- d) Message 26 is no longer transmitted.

10.2.1.13.4 Receive messages

10.2.1.13.5 Purpose

This test will verify that the Base Station is capable of receiving all VDL message types and outputting a VDM to the PI. The contents of binary Message 8 will verify the bit stuffing capability and the correct CRC check of the received messages is also verified.

10.2.1.13.6 Method of measurement

Set up the standard test environment and operate the EUT as defined in the pre-set-up conditions.

- a) Input the following messages to the VDL:
Message 1 through 27 and one undefined.

- b) Apply a simulated position report message with wrong CRC bit sequence to the VDL.
- c) Enable VSI and all TAG block output parameters that are supported by EUT. Apply 90 % channel load on both channels. The input signal level on the EUT shall be between –77 dBm and –7 dBm.

10.2.1.14 Required results

Confirm that:

- a) the EUT outputs each message to the PI with the message content complete and correct;
- b) the message is not output on the PI;
- c) VDM, VSI and all fields of the TAG block are output. Loss of up to 1 % of VDL messages is acceptable.

10.2.2 Addressed and broadcast messaging

10.2.2.1 Normal operations

10.2.2.1.1 Purpose

This test will verify that the Base Station is capable of transmitting both broadcast (Messages 8, 14, 25, 26) and addressed (Messages 6, 12, 25, 26) safety related and binary messages.

10.2.2.1.2 Method of measurement

Set up the standard test environment and operate the EUT as defined in the pre-set-up conditions.

- a) Input the following BBM sentence to the EUT:
!xxBBM,1,1,0,1,8,7E3B3C3E7E,0
- b) Input the following ABM sentence to the EUT:
!xxABM,1,1,2,000001005,1,6,06P0test,0

The following tests are required for a Base Station operated as an independent unit.

- c) Apply the independent mode setup to the EUT.
- d) Input the following BBM sentences to the EUT:
!xxBBM,1,1,0,1,8,7E3B3C3E7E,0
!xxBBM,1,1,0,0,14,D5CDP=5CC175,0
!xxBBM,1,1,4,1,70,up?d45L2N`UKPFI>o8?`00,4
!xxBBM,1,1,5,2,25,up?d45L2N`UKPFI>o8?`00,4
!xxBBM,1,1,6,1,71,up?d45L2N`UKPFI>o8?`00,4
!xxBBM,1,1,7,2,26,up?d45L2N`UKPFI>o8?`00,4
- e) Input the following ABM sentence to the EUT:
!xxABM,1,1,2,<MMSI>,1,6,06P0test,0
!xxABM,1,1,3,<MMSI>,0,12,D5CDP=5CC175,0
!xxABM,1,1,0,<MMSI>,1,70,upGd45L22B2J2B2H,0
!xxABM,1,1,1,<MMSI>,2,25,upGd45L22B2J2B2H,0
!xxABM,1,1,2,<MMSI>,1,71,upGd45L22B2J2B2H,0
!xxABM,1,1,3,<MMSI>,2,26,upGd45L22B2J2B2H,0

The addressed station shall provide the appropriate response, Messages 7 and 13.

- f) Increase the number of reserved slots for the third entry from 2 to 5 to allow the transmission of 5 slot messages.

on the PI when a message is transmitted. Confirm that the ABK sentence with ABK type 3 is output on the PI of the EUT when Messages 8 and 14, 25 and 26 are transmitted;

- e) the EUT is transmitting Messages 6 and 12 once each and two Messages 25 and 26 over the VDL with the specified configuration parameters from the associated ABM sentences within 4 s using available FATDMA slots. Confirm that in Message 25 and 26 the Destination indicator is set to 1 and the correct destination ID is included. Confirm that for Message 25 and 26 the Binary data flag in Message 25/26 is set to 1 and for message 70 and 71 the Binary data flag in Message 25/26 is set to 0. Confirm that the CommState of Message 26 is not allocating slots. Confirm that the appropriate VDO sentence is output on the PI when a message is transmitted. Confirm that the EUT has received the Binary Acknowledgement Message 7 and Safety Related Acknowledgement Message 13 from the addressed station by reviewing the PI VDM sentences. Confirm that the ABK sentence with ABK type 0 is output on the PI of the EUT when acknowledge to Messages 6 and 12 are received;
- f) the slot reservation by DLM has been correctly stored;
- g) the EUT is transmitting Messages 8 and 14 once each over the VDL with the specified configuration parameters from the associated BBM sentences within 4 s using available FATDMA slots. Confirm that the appropriate VDO sentence is output on the PI when a message is transmitted. Confirm that the ABK Sentence with ABK type 3 is output on the PI of the EUT when Messages 8 and 14 are transmitted;
- h) the EUT is transmitting Messages 6 and 12 once each over the VDL with the specified configuration parameters from the associated ABM sentences within 4 s using available FATDMA slots. Confirm that the appropriate VDO sentence is output on the PI when a message is transmitted. Confirm that the EUT has received the Binary Acknowledgement Message 7 and Safety Related Acknowledgement Message 13 from the addressed station by reviewing the PI VDM sentences. Confirm that the ABK sentence with ABK type 0 is output on the PI of the EUT when acknowledge to Messages 6 and 12 are received;
- i) the EUT did not broadcast Message 14. Confirm that the EUT response with an ABK sentence with ABK type '2';
- j) the EUT transmits in correct order according to their priority (Messages 12 before 8). Check that the EUT transmits in free slots within 4 s according to the RATDMA algorithm.

10.2.2.2 Unacknowledged messaging

10.2.2.2.1 Purpose

This test will verify that the Base Station will retry the transmission of an addressed message as defined by the retry field in the BCG sentence.

10.2.2.2.2 Method of measurement

Set up the standard test environment and operate the EUT as defined in the pre-set-up conditions.

The following tests are required for a Base Station operated as an independent unit.

- a) Apply the independent mode setup to the EUT.
- b) Input the following ABM sentence to the EUT to an MMSI other than the 5 test targets in the standard test environment:

```
!xxABM,1,1,0,<MMSI>,0,12,D5CDP=5CC175,0
```

- c) Set the number of VDL message retries to 1 using the BCG sentence:

```
$xxBCG,<UI>,,,,,1,,,,,C
```

Input the following ABM sentence to the EUT to an MMSI other than the 5 test targets in the standard test environment:

```
!xxABM,1,1,0,000006042,0,12,D5CDP=5CC175,0
```

10.2.2.2.3 Required results

The following results are required for a Base Station operated as an independent unit.

Confirm that:

- a) the independent mode setup has been correctly set;
- b) the EUT is transmitting Message 12 over the VDL with the specified configuration parameters from the associated ABM sentence within 4 s using the available FATDMA slot. Confirm that the EUT re-transmits Message 12, within 4 s to 8 s after the previous transmission using the available FATDMA slot, in accordance with the EUT “number of retries” configuration from the BCG sentence. Confirm that the appropriate VDO sentence is output on the PI when a message is transmitted. Confirm that the ABK sentence with ABK type 1 is output on the PI of the EUT after the last transmission of Message 12;
- c) the BCG sentence was received correctly by the EUT using PI query for BCG;
- d) the EUT is transmitting Message 12 over the VDL with the specified configuration parameters from the associated ABM sentence within 4 s using the available FATDMA slot. Confirm that the EUT re-transmits Message 12 once, within 4 s to 8 s using the available FATDMA slot, in accordance with the updated “number of retries”. Confirm that the appropriate VDO sentence is output on the PI when a message is transmitted. Confirm that the ABK type 1 is output on the PI of the EUT after the last transmission of Message 12.

10.2.3 Interrogations and interrogation response

10.2.3.1 Interrogation transmission

10.2.3.1.1 Purpose

This test will verify that the Base Station can transmit an interrogation, Message 15.

10.2.3.1.2 Method of measurement

Set up the standard test environment and operate the EUT as defined in the pre-setup conditions.

The following tests are required for a Base Station operated as an independent unit.

- a) Apply the independent mode setup to the EUT.
- b) Input an AIR sentence, with a definition of reply slots, to the EUT; interrogate for Messages 3, 4, 5, 9, 17, 18, 19, 20, 21, 22, 24.

10.2.3.1.3 Required results

The following results are required for a Base Station operated as an independent unit.

Confirm that:

- a) the Independent mode setup has been correctly set;
- b) the EUT is transmitting Message 15 over the VDL with the specified configuration parameters from the associated AIR sentence within 4 s using an available FATDMA slot. Confirm that the Slot offset parameter of Message 15 is correctly calculated from the actual Tx slot and the reply slot parameter of the AIR sentence. Confirm that the appropriate VDO sentence is output on the PI when a message is transmitted. Confirm that the EUT outputs an ABK with ABK type 3 to the PI after Message 15 has been transmitted.

10.2.3.2 Interrogation response

10.2.3.2.1 Purpose

This test will verify the ability of the Base Station to respond to an interrogation request.

10.2.3.2.2 Method of measurement

Set up the standard test environment and operate the EUT as defined in the pre-set-up conditions.

- a) Apply a Message 15 onto the VDL, addressing the EUT requesting Messages 4 and 24.

The following tests are required for a Base Station operated as an independent unit.

- b) Apply the independent mode setup to the EUT.
- c) Apply a Message 15 onto the VDL, addressing the EUT requesting Messages 4 and 24.
- d) Apply a Message 15 onto the VDL, addressing the EUT requesting Message 1.
- e) Stop the transmission of Message 4 and 20 and enable RATDMA. Apply a Message 15 onto the VDL, addressing the EUT requesting Message 4.

10.2.3.2.3 Required results

Confirm that:

- a) there is a VDM output of the received Message 15 but the EUT does not respond.

The following results are required for a Base Station operated as an independent unit:

- b) the independent mode setup has been correctly set;
- c) the EUT does not transmit Message 4, in addition to the scheduled transmissions as determined by the ECB sentence. Check that the EUT transmits Message 24A with the base station name, and 24B with the Vendor ID, in response to the request for Message 24. Confirm that the appropriate VDO sentences are output on the PI when the messages are transmitted;
- d) the EUT does not transmit Message 1;
- e) the transmission of Message 4 is stopped. Check that the EUT transmits the appropriate Message 4 within 4 s. Confirm that the appropriate VDO sentence is output on the PI when a message is transmitted. Check that the EUT does not transmit Message 20.

10.2.4 Addressed operation

10.2.4.1 Purpose

This test will verify that the Base Station will respond to addressed messages with the appropriate message type. This test will also verify that the Base Station does not respond to messages that are not addressed to the EUT.

10.2.4.2 Method of measurement

Set up the standard test environment and operate the EUT as defined in the pre-set-up conditions.

- a) Apply a Message 6 onto the VDL, addressed to the EUT.
- b) Apply a Message 12 onto the VDL, not addressed to the EUT.
- c) Apply a Message 10 onto the VDL, addressed to the EUT.

The following tests are required for a Base Station operated as an independent unit.

- d) Apply the independent mode setup to the EUT.

- e) Apply a Message 6 onto the VDL, addressing the EUT.
- f) Apply a Message 12 onto the VDL, not addressing the EUT.
- g) Apply a Message 10 onto the VDL, addressing the EUT.

10.2.4.3 Required results

Confirm that:

- a) the EUT does not transmit an acknowledgement;
- b) the EUT does not transmit an acknowledgement;
- c) the EUT does not transmit a response;

The following results are required for a Base Station operated as an independent unit.

- d) the independent mode setup has been correctly set;
- e) the EUT transmits Message 7 as a response. Check for the VDM and VDO sentences output using the PI;
- f) the EUT does not transmit Message 13 as a response. Check for the VDM sentence output using the PI;
- g) the EUT transmits a Message 4 as a response. Check for the VDM and VDO sentence output using the PI.

10.2.5 Slot phase and frame synchronisation – Base Station operation

10.2.5.1 UTC direct

10.2.5.1.1 Purpose

This test will verify that the Base Station will operate as required with UTC direct synchronisation mode. This test will also verify synchronisation jitter.

10.2.5.1.2 Method of measurement

Set up the standard test environment and operate the EUT as defined in the pre-set-up conditions.

- a) Disable the UTC source for the Base Station. Insert multiple Message 1(s) on the VDL with CommState 0, indicating UTC direct.

Apply multiple pairs of a TSA sentence and a VDM sentence with encapsulated Message 8 to the EUT:

```
$xxTSA,<UI>,7,B,<UTC h+m>,1001,2
!xxVDM,1,1,7,B,8h3OHqh0J7ps?3qv,0
```

- b) Restore the UTC source to the Base Station.

Apply multiple pairs of a TSA sentence and a VDM sentence with encapsulated Message 8 to the EUT:

```
$xxTSA, <UI>,7,B, <UTC h+m>,<Txslot>,2
!xxVDM,1,1,7,B,8h3OHqh0J7ps?3qv,0
```

The following tests are required for a Base Station operated as an independent unit.

- c) Apply the independent mode setup to the EUT.
- d) Disable the UTC source for the Base Station. Insert multiple Message 1(s) on the VDL with CommState 0, indicating UTC direct.
- e) Restore the UTC source to the Base Station.

10.2.5.1.3 Required results

Confirm that:

- a) the EUT is transmitting Message 8 in the assigned slot and channel. Verify synchronisation jitter does not exceed $\pm 156 \mu\text{s}$ as required for UTC indirect. Confirm that the EUT outputs ALR ID 007 via PI with the appropriate status value. Confirm that the ADS indicates the correct Sync. State and alarm status;
- b) the EUT is transmitting Message 8 in the assigned slot and channel. Verify synchronisation jitter does not exceed $\pm 52 \mu\text{s}$ as required for UTC direct. Confirm that the ADS indicates the correct Sync. State and alarm status.

The following results are required for a Base Station operated as an independent unit:

- c) the independent mode setup has been correctly set;
- d) the Base Station maintains the same reporting rate for Message 4 but changes the CommState to 1. Verify synchronisation jitter does not exceed $\pm 156 \mu\text{s}$ as required for UTC indirect. Confirm that the slot length is 26,67 ms. Confirm that the EUT outputs ALR ID 007 via PI with the appropriate status value. Confirm that the ADS indicates the correct Sync. State and alarm status;
- e) the CommState of the Message 4(s) is 0, indicating UTC direct. Confirm that the EUT outputs ALR ID 007 via PI with the appropriate status value. Confirm that the ADS indicates the correct Sync. State and alarm status.

10.2.5.2 UTC indirect to a Base Station

10.2.5.2.1 Purpose

This test will verify that the Base Station will operate as required with UTC indirect synchronisation mode. This test will also verify synchronisation jitter.

10.2.5.2.2 Method of measurement

Set up the standard test environment and operate the EUT as defined in the pre-set-up conditions.

- a) Disable the UTC source for the Base Station.

Insert Message 1(s) on the VDL with CommState 0, indicating UTC direct.

Insert Message 4(s) on the VDL with CommState 0, indicating UTC direct with a position distance of 120 NM at the slot following the EUT Message 8 transmission.

Apply multiple pairs of a TSA sentence and a VDM sentence with encapsulated Message 8 to the EUT:

```
$xxTSA,<UI>,7,B,<UTC h+m>,<TxSlot>,2
```

```
!xxVDM,1,1,7,B,8h3OHqh0J7ps?3qv,0
```

- b) Restore the UTC source to the Base Station.

Apply a TSA sentence and a VDM sentence with encapsulated Message 8 to the EUT:

```
$xxTSA,<UI>,7,B,<UTC h+m>,1001,2
```

```
!xxVDM,1,1,7,B,8h3OHqh0J7ps?3qv,0
```

The following tests are required for a Base Station operated as an independent unit.

- c) Apply the independent mode setup to the EUT.

- d) Disable the UTC source for the Base Station.

Insert Message 1(s) on the VDL with CommState 0, indicating UTC direct with a position distance of 120 NM.

Insert Message 4(s) on the VDL with CommState 0, indicating UTC direct with a position distance of 120 NM at the slot following the EUT Message 4 transmission.

- e) Restore the UTC source to the Base Station.

10.2.5.2.3 Required results

Confirm that:

- a) the EUT is transmitting Message 8 in the assigned slot and channel. Verify synchronisation jitter does not exceed $\pm 156 \mu\text{s}$ as required for UTC indirect, taking into account the propagation delay (0,74 ms delay for 120 NM) of the received Message 4. Confirm that the EUT outputs ALR ID 007 via PI with the appropriate status value. Confirm that the ADS sentence indicates the correct Sync. State and alarm status;
- b) the EUT is transmitting Message 8 in the assigned slot and channel. Confirm that the ADS sentence indicates the correct Sync. State and alarm status.

The following results are required for a Base Station operated as an independent unit.

- c) the independent mode setup has been correctly set;
- d) the Base Station maintains the same reporting rate for Message 4 but changes the CommState to 1 using the Base Station as UTC indirect sync source. Verify synchronisation jitter does not exceed $\pm 156 \mu\text{s}$ as required for UTC indirect, taking into account the propagation delay of the received Message 4. Confirm that the EUT outputs ALR ID 007 via PI with the appropriate status value. Confirm that the ADS sentence indicates the correct Sync. State and alarm status;
- e) the Sync. State in the CommState of Message 4(s) is 0, indicating UTC direct. Confirm that the EUT outputs ALR ID 007 via PI with the appropriate status value. Confirm that the ADS sentence indicates the correct Sync. State and alarm status.

10.2.5.3 Synchronised to Base Station

10.2.5.3.1 Purpose

This test will verify that the Base Station will operate as required with indirect synchronisation to Base Station. This test will also verify synchronisation jitter.

10.2.5.3.2 Method of measurement

Set up the standard test environment and operate the EUT as defined in the pre-set-up conditions.

- a) Disable the UTC source for the Base Station. Insert Message 4(s), with a lower MMSI than the EUT, with Sync. State 3, indicating semaphore operation.

Apply multiple pairs of a TSA sentence and a VDM sentence with encapsulated Message 8 to the EUT:

```
$xxTSA,<UI>,7,B,<UTC h+m>,<TxSlot>,2
!xxVDM,1,1,7,B,8h3OHqh0J7ps?3qv,0
```

- b) Restore the UTC source to the Base Station.

Apply a TSA sentence and a VDM sentence with encapsulated Message 8 to the EUT:

```
$xxTSA,<UI>,7,B,<UTC h+m>,1001,2
!xxVDM,1,1,7,B,8h3OHqh0J7ps?3qv,0
```

The following tests are required for a Base Station operated as an independent unit.

- c) Apply the independent mode setup to the EUT
- d) Disable the UTC source for the Base Station. Insert Message 4(s), with a lower MMSI than the EUT, with Sync. State 3, indicating semaphore operation.

e) Restore the UTC source to the Base Station.

10.2.5.3.3 Required results

Confirm that:

- a) the EUT is transmitting Message 8 in the assigned slot and channel. Confirm that the EUT does not transmit Message 4. Verify synchronisation jitter of the Message 8 does not exceed $\pm 104 \mu\text{s}$ compared to the received Message 4(s). Confirm that the EUT outputs ALR ID 007 via PI with the appropriate status value. Confirm that the ADS sentence indicates the correct Sync. State and alarm status;
- b) the EUT is transmitting Message 8 in the assigned slot and channel. Confirm that the ADS sentence indicates the correct Sync. State and alarm status.

The following results are required for a Base Station operated as an independent unit:

- c) the independent mode setup has been correctly set;
- d) the Base Station maintains the reporting interval of 10 s for Message 4 and changes the Sync. State in CommState to 2. Verify synchronisation jitter does not exceed $\pm 104 \mu\text{s}$ as required for UTC indirect. Confirm that the EUT outputs ALR ID 007 using PI with the appropriate status value. Confirm that the ADS sentence indicates the correct Sync. State and alarm status;
- e) the Sync. State of the Message 4(s) is 0, indicating UTC direct. Confirm that the EUT outputs ALR ID 007 via PI with the appropriate status value. Confirm that the ADS indicates sentence the correct Sync. State and alarm status.

10.2.5.4 As semaphore

10.2.5.4.1 Purpose

This test will verify that the Base Station will operate as semaphore. This test will also verify synchronisation jitter.

10.2.5.4.2 Method of measurement

The following tests are required for a Base Station operated as an independent unit.

Set up the standard test environment and operate the EUT as defined in the pre-set-up conditions.

- a) Apply the independent mode setup to the EUT.
- b) Disable the UTC source for the Base Station. Insert Message 1(s) with Sync. State 3, indicating semaphore operation by 2 s reporting interval, onto the VDL.
- c) Restore the UTC source to the Base Station and insert Message 1(s) with Sync. State 1 indicating UTC indirect.
- d) Disable the UTC source for the Base Station. Insert Message 1(s) with Sync. State 2, indicating Base Station synchronisation, onto the VDL.
- e) Restore the UTC source to the Base Station and insert Message 1(s) with Sync. State 1 indicating UTC indirect.

10.2.5.5 Required results

The following results are required for a Base Station operated as an independent unit.

Confirm that:

- a) the independent mode setup has been correctly set;
- b) the Base Station increases its Message 4, reporting rate to 3 1/3 s. Verify that the Sync. State of the Message 4(s) is 3, indicating semaphore operation. Confirm that the EUT

outputs ALR ID 007 using PI with the appropriate status value. Confirm that the ADS sentence indicates the correct Sync. State and alarm status;

- c) the Sync. State of the Message 4(s) is 0, indicating UTC direct. Verify that 3 min after the restoration of the UTC source, the Base Station decreases its reporting rate to 10 s. Confirm that the ADS indicates the correct Sync. State and alarm status;
- d) the Base Station increases its Message 4, reporting rate to 3 1/3 s. Verify that the Sync. State of the Message 4(s) is 3, indicating semaphore operation. Confirm that the EUT outputs ALR ID 007 using PI with the appropriate status value. Confirm that the ADS sentence indicates the correct Sync. State and alarm status;
- e) the Sync. State of the Message 4(s) is 0, indicating UTC direct. Verify that 3 min after the restoration of the UTC source, the Base Station decreases its reporting rate to 10 s. Confirm that the EUT outputs ALR ID 007 via PI with the appropriate status value. Confirm that the ADS sentence indicates the correct Sync. State and alarm status.

10.2.6 Position source

10.2.6.1 Purpose

This test will verify that the Base Station will accept and correctly handle each position source setting. In addition, this test will verify that the Base Station responds correctly if a position source is lost.

10.2.6.2 Method of measurement

Set up the standard test environment and operate the EUT as defined in the pre-setup conditions.

The following tests are required for a Base Station operated as an independent unit.

- a) Apply the independent mode setup to the EUT.
- b) Set the position source to surveyed position using the BCL sentence:
\$xBCL,<UI>,0,,,,,,C
- c) If implemented, set the position source to internal position source:
\$xBCL,<UI>,1,,,,,,C
- d) Remove the GPS antenna to generate a failure for the position.
- e) If implemented, set the position source to external position source. Supply the EUT, using the PI, a series of GGA, RMC, or GLL sentences.
\$xBCL,<UI>,2,,,,,,C
- f) Discontinue the position sentences for 30 s.
- g) Set the position source to surveyed position:
\$xBCL,<UI>,1,,,,,,C
- h) Repeat steps c) and d) using the following position sources:
3 = internal EPFS in use with automatic fall back to surveyed position;
4 = internal EPFS in use with automatic fall back to external EPFS upon failure of internal EPFS.
- i) Repeat steps e) and f) using the following position sources:
5 = external EPFS in use with automatic fall back to surveyed position;
6 = external EPFS in use with automatic fall back to internal position source upon failure of external position source.

10.2.6.3 Required results

The following results are required for a Base Station operated as an independent unit.

Confirm that:

- a) the independent mode setup has been correctly set;
- b) the BCL sentence was received correctly by the EUT using PI query for BCL. Confirm that the EUT transmits the Message 4 with a position source indicating surveyed. Confirm that the ADS sentence indicates the position source “S”;
- c) the BCL sentence was received correctly by the EUT using PI query for BCL. Confirm that the EUT transmits the Message 4 with a position source indicating internal. Confirm that the ADS sentence indicates the position source “I”;
- d) the ALR sentence with ID 26 is output on the PI indicating a loss of position source. Confirm that the EUT transmits the Message 4 with no position available. Confirm that the ADS sentence indicates the position source “N”;
- e) the BCL sentence was received correctly by the EUT using PI query for BCL. Confirm that the EUT transmits the Message 4 with a position source indicating the EPFS type of the external sensor. Confirm that the ADS sentence indicates the position source “E”;
- f) the ALR sentence with ID 26 is output using the PI indicating a loss of position source. Confirm that the EUT transmits the Message 4 with no position available. Confirm that the ADS sentence indicates the position source “N”;
- g) the BCL sentence was received correctly by the EUT using PI query for BCL. Confirm that the EUT transmits Message 4 with a position source indicating surveyed. Confirm that the ADS sentence indicates the position source “S”;
- h) for each position source:
 - i) the BCL sentence was received correctly by the EUT using PI query for BCL;
the EUT transmits Message 4 with a position source indicating internal;
the ADS sentence indicates the current position source;
the EUT transmits Message 4 with required fall-back position source;
the ADS sentence indicates the current position source;
 - j) for each position source:
 - the BCL sentence was received correctly by the EUT using PI query for BCL;
 - the EUT transmits Message 4 with a position source indicating the EPFS type of the external sensor;
 - the ADS sentence indicates the current position source;
 - the EUT transmits Message 4 with required fall-back position source;
 - the ADS sentence indicates the current position source.

10.2.7 Alarm messages

10.2.7.1 Purpose

This test will verify that the Base Station will output alarm messages as required by Table 12.

10.2.7.2 Method of measurement

Set up the standard test environment and operate the EUT as defined in the pre-setup conditions.

- a) Disconnect the transmit antenna from the EUT. Apply a TSA+VDM sentence pair to activate a transmission.
- b) Provide the EUT with an ACK with alarm ID 001 using the PI.
- c) Reconnect the transmit antenna to remove the alarm condition. Apply a TSA+VDM sentence pair to activate a transmission.
- d) Prevent the EUT from radiating with full power by mismatching the antenna for a VSWR of 3:1. Apply a TSA+VDM sentence pair to activate a transmission.

- e) Provide the EUT with an ACK with alarm ID 002 using the PI.
- f) Reconnect the transmit antenna to remove the alarm condition. Apply a TSA+VDM sentence pair to activate a transmission.

10.2.7.3 Required results

Confirm that:

- a) the EUT continues to generate an ALR sentence with alarm value 1 to the PI at least once per minute;
- b) the EUT generates an ALR sentence with alarm ID 001 with an acknowledged status once the ACK has been received;
- c) the EUT generates an ALR sentence with an ALR ID 001 and Status V, V in the alarm condition and acknowledgement field;
- d) the EUT continues to generate an ALR sentence with alarm ID 002 to the PI once per minute;
- e) the EUT generates an ALR sentence with alarm ID 002 with an acknowledged status once the ACK has been received;
- f) the EUT generates an ALR sentence with a ALR ID 002 and Status V, V and every minute an ALR sentence with null value in the alarm ID field and Status V, V in the alarm condition and acknowledgement field.

10.3 Selection of transmission slots

10.3.1 RATDMA Transmission

10.3.1.1 Method of measurement

Set up standard test environment and operate EUT in the pre-set conditions. RATDMA shall be enabled.

- a) Provide 50 % channel loading using Message 1, ensuring there are at least 4 free slots in each SI. Wait at least 1 min, then transmit 100 single slot binary Message 8 using RATDMA.
- b) Repeat the test with 50 % channel loading by Message 26 with valid CommStates ensuring there are at least 4 free slots in each SI.

10.3.1.2 Required results

Check that:

- a) only free slots are used for transmission;
- b) only free slots are used for transmission.

10.3.2 Intentional slot reuse (link congestion)

10.3.2.1 Purpose

Verify that the EUT will operate properly in a >90 % load environment.

10.3.2.2 Method of measurement

Set up the standard test environment and operate the EUT as defined in the pre-setup conditions. Ensure that the signal level received from the EUT exceeds the signal level received from the test transmitter at the test receiver location.

- a) Set up additional test targets to simulate a VDL load of >90 % which include base stations both within and beyond 120 NM and remotely allocated FATDMA slots. Wait at least 1 min.

- b) Apply a TSA sentence and a VDM sentence with encapsulated Message 8 to the EUT.

The following tests are required for a Base Station operated as an independent unit.

- c) Apply the independent mode setup to the EUT. Enable RATDMA:
 d) Wait at least 1 min, then transmit 100 single slot binary Message 8 using RATDMA.

10.3.2.3 Required results

Confirm that:

- a) the EUT generates the required VDM sentences for all messages;
 b) the EUT transmits in the assigned slot and channel. Confirm that the EUT generates the required TFR with status 0.

The following results are required for a Base Station operated as an independent unit:

- c) the independent mode setup has been correctly set. Confirm that RATDMA has been enabled. Confirm that the EUT continues to generate the required VDM sentences for all messages;
 d) the slot used by the slot reuse algorithm is a random selection within the candidate slots (4 most distant stations). Check that a station is not subject to slot reuse more than once a frame. Check that slots allocated by a local Base Station, for own use or for use by remote base station, are not subject to slot reuse. Check that slots reserved by a Base Station within the 120 nautical miles are not subject to slot reuse. Check that slots reserved by a Base Station beyond the 120 nautical miles are subject to slot reuse.

10.4 Legacy support

10.4.1 Purpose

This test verifies that the legacy sentences BCE, BCF, CAB and TSP are correctly supported in addition to the new sentences BCG, BCL, RST and TPC. This test also verifies that the sentences ACM, AGA, ASN, DLM, ECB and SPO which have an additional "Sentence status flag" field are accepted without the Sentence status flag field. (See Table 1.)

This test is only applicable if the manufacturer declares that the legacy sentences are supported.

10.4.2 Method of measurement

Set up standard test environment and apply the dependent mode pre-setup conditions.

- a) Apply a TSP to prohibit the use of slots.

```
$xxTSP,<UI>99,A,<hhmmss>,0,1000,5,,,,
```

Apply a TSA+VDM of Message 14 that uses the prohibited slots reserved by the TSP.

```
$xxTSA,<UI>,7,A, <UTC h+m>,1001,2
```

```
!xxVDM,1,1,7,B,>h3OHqi@E=@,2
```

- b) Apply a BCE sentence with RATDMA control, UTC source and ADS interval different to the current setting. Apply a BCF sentence with all data except the MMSI different to the current settings. Query for BCE and BCF.
 c) Query for BCG and BCL
 d) Restart the EUT using the following CAB sentence:

```
$xxCAB,,,1,
```

 e) Reset the EUT using the following CAB sentence:
 f)

```
$xxCAB,,,,1
```

- g) Apply the independent mode setup as defined in 10.1.3 using ECB and DLM sentences without Sentence status flag field.
- h) Initiate a single transmission of an MMSI addressed Message 22 using an ACM sentence without Sentence status flag field like the following example:

```
$xxACM, <MMSI of mobile 1>,<MMSI of mobile 2>,<Ch.A>,0,<Ch.B>,0,0,0,<Tx Channel>,3,C
```
- i) Apply an AGA sentence without Sentence status flag field for Message 23 content for station type 1.
- j) Input the ASN sentence as in 10.2.1.10.2 b) without Sentence status flag field
- k) Apply the following SPO sentence without Sentence status flag field to the EUT:

```
$xxSPO,<UI>,A,1,1,1,,1,,1,1,1,1
```

10.4.3 Required results

Confirm that:

- a) the EUT generates a TSR sentence with status 0. Confirm that the EUT generates a TFR sentence with status 7 for the TSA/VDM of Message 14 for the prohibited slot;
- b) the EUT outputs an BCE and BCF sentence with correct data according to the input sentences;
- c) the EUT outputs an BCG and BCL sentence with correct data according to the setting by BCE and BCF;
- d) the EUT restarts and starts receiving on channel A and B within 2 min. Confirm that all settings are retained;
- e) the EUT restarts and starts receiving on the defaults channel A and B within 2 min. Confirm that all configuration information is reset to the default values as defined in 6.5. Confirm that the Unique identifier and the MMSI have not been reset;
- f) by query that the slot reservation and transmission schedule are correctly set. Confirm that the EUT is transmitting Message 4 and Message 20 in the assigned slots, interval, and channels as defined in the ECB sentences. Confirm that the content of Message 20 is as defined by the DLM;
- g) the EUT transmits an MMSI addressed Message 22 within the 4 s. Confirm the content of the Message 22 is as defined by the ACM sentence;
- h) the AGA sentences for Message 23 were received correctly by the EUT using the query sentence for the AGA sentence;
- i) Message 16 is transmitted as required in 10.2.1.10.2 b);
- j) by query for SPO that the SPO settings are correctly stored. Confirm that a VSI sentence is output for each VDM or VDO sentence containing the associated information according to Table 10. Confirm that an FSR sentence is output at the end of each frame containing the associated information according to Table 10 about the conditions for the previous frame.

10.5 TAG Block encapsulation

10.5.1 Application

This test will verify that the Base Station can respond to TAG Blocks and generate TAG blocks properly as defined in Table 14.

In most tests a query for a VER sentence and a VER response is used. This can be replaced by other sentences which initiate a response by the EUT.

Only tests of functions which are implemented have to be performed.

10.5.2 TAG Block capabilities

10.5.2.1 Purpose

This test verifies that the EUT responds to a request on TBR with output sentences providing the correct capability information.

10.5.2.2 Method of measurement

Set up the standard test environment and operate the EUT as defined in the pre-setup conditions.

- a) Apply a TBR (Tag Block Report Request) sentence to the EUT with the correct Unique Identifier (UI) of the EUT and the Request flag set to "S" requesting all supported TAG block functions.
- b) Apply a query for TBS.

10.5.2.3 Required results

Confirm that:

- a) the EUT outputs the sentences CPD, CPG, CPS, CPC and CPN with Talker and Listener function field set to "V" (supported but disabled). The Listener function of CPC, CPG and CPN can be set to "U" (Unsupported) depending on the implementation;
- b) there is one TBS output with the Source identification field set to null field.

10.5.3 Activation of Source identification for output

10.5.3.1 Purpose

This test verifies that the EUT provides the correct TAG blocks containing the Source identification with the output sentences, depending on the configuration.

10.5.3.2 Method of measurement

Set up the standard test environment and operate the EUT as defined in the pre-setup conditions.

- a) Apply a CPS sentence (Configure Parameter code for the Source identification parameters) to the EUT, with the Talker Source identification function set to "N" (enabled for NAK reply only) and the Listener Source identification function set to "V" (disabled). Apply a TBR sentence.
- b) Apply a sentence to the EUT which causes a NAK response. The manufacturer shall provide information on how to get a NAK response.
- c) Apply a CPS sentence to the EUT, with the Talker Source identification function set to "A" (enabled) and the Listener Source identification function set to "V" (disabled). Apply a TBR sentence.
- d) Apply a query for a VER sentence.

10.5.3.3 Required results

Confirm that:

- a) the EUT outputs a CPS sentence with the correct settings and the Sentence status flag set to "R" (report). Confirm that the output does not include TAG blocks;
- b) the EUT outputs a NAK sentence with a preceding correct TAG block, including the Source identification parameter set to the own Unique Identifier (applied by SID sentence);

- c) the EUT outputs a CPS sentence with the correct settings, with a TAG block where Source identification = own UI. Confirm that all sentences are output with TAG blocks containing a Source identification;
- d) a VER sentence is output with a TAG block where Source identification = own UI.

10.5.4 Activation of Destination identification

10.5.4.1 Purpose

This test verifies that the EUT provides the correct Destination identification with the output sentences and performs the correct filtering of input sentences with TAG blocks containing a Destination identification parameter.

10.5.4.2 Method of measurement

Set up the standard test environment and operate the EUT as defined in the pre-setup conditions.

- a) Apply an CPD sentence (Configure Parameter code for the Destination identification parameters) without TAG block to the EUT, with the Talker Destination identification function set to "A" (enabled) and the Listener Destination identification function set to "V" (disabled). Apply a TBR sentence.
- b) Apply a query for VER, without a TAG block.
- c) Apply a query for VER, with a TAG block containing a Source identification and the correct Destination identification (UI of EUT).
- d) Apply a query for VER, with a TAG block containing a Source identification and a Destination identification different to the UI of EUT.
- e) Apply an CPD sentence (Configure Parameter code for the Destination identification parameters) to the EUT, with the Talker Destination identification function set to "A" (enabled) and the Listener Destination identification function set to "A" (enabled). Apply a TBR sentence with the correct Source and Destination identification.
- f) Apply a query for VER, without TAG blocks.
- g) Apply a query for VER, with a TAG block containing a Source identification and the correct Destination identification (UI of EUT).
- h) Apply a query for VER, with a TAG block containing a Source identification and a Destination identification different to the UI of EUT.

10.5.4.3 Required results

Confirm that:

- a) the EUT outputs a CPD sentence with the correct settings. Confirm that the output sentence is preceded by a TAG block with Source identification = own UI and no Destination identification. Confirm that all output sentences which are not a response on an input sentence do not include a Destination identification in the TAG block.
- b) a VER sentence is output with a TAG block where Source identification = own UI and no Destination identification;
- c) a VER sentence is output with a TAG block where Source identification = own UI and the Destination identification = Source identification of the query TAG block;
- d) a VER sentence is output with a TAG block where Source identification = own UI and the Destination identification = Source identification of the query TAG block;
- e) the EUT outputs a CPD sentence with the correct settings. Confirm that the output sentence is preceded by a TAG block where Source identification = own UI and Destination identification = Source identification of the TAG block of the input TBR sentence;
- f) there is no VER response;

- g) a VER sentence is output with a TAG block where Source identification = own UI and the Destination identification = Source identification of the query TAG block;
- h) there is no VER response.

10.5.5 Activation of Source identification for input

10.5.5.1 Purpose

This test verifies the correct storage of Source identification parameters and the correct input filtering by Source identification parameters in input TAG blocks.

10.5.5.2 Method of measurement

Set up the standard test environment and operate the EUT as defined in the pre-setup conditions.

- a) Apply a TBS sentence to the EUT containing a valid Source identification S1, the Action field set to 1 = add the provided Source identification value. Query for TBS.
- b) Apply a query for VER, with a TAG block containing a Source identification different to the stored Source identification S1.
- c) Apply a CPS sentence to the EUT, with the Talker Source identification function set to "A" (enabled) and the Listener Source identification function set to "A" (enabled). Apply a TBR Sentence with a Source identification S1.
- d) Apply a query for VER, with a TAG block not containing a Source identification parameter.
- e) Apply a query for VER, with a TAG block containing a Source identification equal to the stored Source identification S1.
- f) Apply a query for VER, with a TAG block containing a Source identification different to the stored Source identification S1.
- g) Apply a query for VER, with a TAG block containing a Source identification "DEFAULTSOURCE".

10.5.5.3 Required results

Confirm that:

- a) the EUT outputs a TBS sentence with the correct Source identification S1. Confirm that there is no TBS output sentence for the Source identification of "DEFAULTSOURCE";
- b) there is a VER response;
- c) the EUT outputs a CPS sentence with the correct activation settings, Talker = A and Listener = A;
- d) there is no VER response;
- e) there is a VER response with the Destination identification;
- f) there is no VER response;
- g) there is a VER response without Destination identification.

10.5.6 Use of multiple Source identifications for input

10.5.6.1 Purpose

This test verifies the correct storage of multiple Source identifications and the correct input filtering by Source identification parameters in input TAG blocks.

10.5.6.2 Method of measurement

Set up the standard test environment and operate the EUT as defined in the pre-setup conditions.

- a) Apply TBS sentences to the EUT containing valid Source identification S2, S3, ..., Sn according to the maximum number of Source identifications provided by the manufacturer. The CPS setting of S1 from the previous test is still valid. Query for TBS using a valid Source identification in the TAG block.
- b) Apply query sentences for VER, one query for each applied Source identification with a TAG block containing the appropriate Source identification.
- c) Apply a query for VER, with a TAG block containing a Source identification which is not part of the stored Source identifications.
- d) Apply one more TBS sentence(s) which would exceed the maximum number of Source identifications which can be stored by the EUT. Query for TBS.
- e) Apply a TBS sentence to the EUT containing the Source identification S2 as applied in test a) with the Action field set to 2 (Remove the provided Source identification). Query for TBS.
- f) Apply TBS sentences to the EUT containing no Source identification value, with the Action field set to 3 (Remove all Source identifications). Query for TBS.
- g) Apply a query sentence for VER, with a TAG block containing the Source identification value "DEFAULTSOURCE".

10.5.6.3 Required results

Confirm that:

- a) the EUT outputs a TBS sentence with the correct Source identifications S1, S2, S3, ..., Sn for each applied TBS sentence. Confirm that at least 5 Source identifications can be stored. Confirm that there is no TBS output sentence for the Source identification of "DEFAULTSOURCE";
- b) there is a VER response for each query, with Destination identification = Source identification of the query TAG block;
- c) there is no VER response;
- d) there is a NAK response on the TBS sentence indicating that the Source identification cannot be stored. Confirm that there is a TBS sentence for Source identification S1 and for each Source identification stored under step a);
- e) the EUT outputs a TBS sentence with the correct Source identification S1, S3, ..., Sn for each stored Source identification. Confirm that there is no TBS output sentence for the Source identification S2 which has been removed;
- f) there is one TBS output with the Source identification field set to null field;
- g) there is a VER response. This indicates that the default Source identification has not been deleted.

10.5.7 Test of grouping by TAG blocks for output

10.5.7.1 Purpose

This test verifies the grouping of sentences using TAG block grouping parameter "g:" for output sentences.

10.5.7.2 Method of measurement

Set up the standard test environment and operate the EUT as defined in the pre-setup conditions.

- a) Apply a CPS and a CPD sentence to disable Source identification and Destination identification (Talker and Listener function set to "V"). Apply a TBR sentence with the Request flag set to "S" requesting all supported TAG block functions.
- b) Input SPO sentences to activate VSI sentences for VDM.

- c) Apply a CPG sentence to activate the Talker grouping function (Talker function set to “A” and Listener function set to “V”). Set the Reset event to “0” = use the Group-code limit. Set the Initial Group-code and the Group-code increment to 1 (default). The Group-code limit is set to a small integer value (e.g. 10). Apply a TBR sentence.

The following tests are performed only if the optional functions are implemented.

- d) Apply a CPG sentence with Talker function set to “A” and Listener function set to “V”. Set the Reset event to “0” = use the Group-code limit. Set the Initial group-code to 100 and the Group-code increment to 10. The Group-code limit is set to 250. Apply a TBR sentence.
- e) Apply a SPO sentence to activate VSI sentences for VDM and VDO. Apply a CPD and CPS sentence to activate Destination identification and Source identification for Talker. Apply a CPG sentence to activate the Talker grouping function (Talker function set to “A” and Listener function set to “V”). Set the Reset event to “3” = every minute. Set the Initial group-code to 200 and the Group-code increment to –5. The Event offset value is set to –10. Apply a TBR sentence.

10.5.7.3 Required results

Confirm that:

- a) the EUT outputs the sentences CPD, CPG, CPS, CPN and CPC with Talker and Listener function field set to “V” (supported but disabled). The Listener function of CPC, CPG and CPC can be set to “U” (Unsupported) depending on the implementation;
- b) the EUT outputs VSI sentences together with all VDM sentences. Confirm that no TAG blocks are added;
- c) the response on TBR includes a CPG sentence with the input parameters. Confirm that single line sentences (e.g. VDO) are output without TAG blocks. Confirm that all VSI/VDM combinations and all multi-part VDM and VDO sentences are grouped using TAG blocks. Confirm that the x parameter in the g: string starts with 1 and is incremented by 1 for each sentence in a group. Confirm that the y parameter is identical for each sentence in a group and indicates the total number of sentences of this group. Confirm that the code parameter is identical for each sentence in a group and is incremented by the defined Group-code increment parameter (=1) for each group. Confirm that the code parameter is reset to the defined Initial group code (=1) when it would exceed the defined Group-code limit (e.g. = 10);
- d) the TBR response includes a CPG sentence with the input parameters. Confirm that all VSI/VDM combinations and multi-part VDM and VDO messages are grouped using TAG blocks with the correct parameters. Confirm that the x parameter in the g: string starts with 1 and is incremented by 1 for each sentence in a group. Confirm that the y parameter is identical for each sentence in a group and indicates the total number of sentences of this group. Confirm that the code parameter is identical for each sentence in a group and is incremented by the defined Group-code increment parameter (=10) for each group. Confirm that the code parameter is reset to the defined Initial group code (=100) when it would exceed the defined Group-code limit (= 250);
- e) the TBR response includes a CPG sentence with the input parameters. Confirm that all VSI/VDM and VSI/VDO combinations and multi-part VDM and VDO messages are grouped using TAG blocks with the correct parameters. Confirm that the grouping parameter is always the first parameter in a TAG block. Confirm that the x parameter in the g: string starts with 1 and is incremented by 1 for each sentence in a group. Confirm that the y parameter is identical for each sentence in a group and indicates the total number of sentences of this group. Confirm that the code parameter is identical for each sentence in a group and is decremented by the defined Group-code increment parameter (=-5) for each group. Confirm that the code parameter is reset to the defined Initial group code (=200) 10 s (Event offset parameter) before the beginning of each minute.

10.5.8 Test of UNIX time output

10.5.8.1 Purpose

This test verifies the output of the TAG block parameter “c” with the UNIX time value.

10.5.8.2 Method of measurement

Set up the standard test environment and operate the EUT as defined in the pre-setup conditions.

- a) Apply a CPC sentence (Configure Parameter code for UNIX time parameter) with the Talker UNIX time function set to „A” (enabled) and the Listener UNIX time function set to “V” (disabled). The Time precision/Format parameter shall be set to 1=integer seconds. Apply a TBR sentence
- b) Apply a CPC sentence with the Talker UNIX time function set to „A” (enabled) and the Time precision/ Format parameter set to 2=integer milliseconds.

10.5.8.3 Required results

Confirm that:

- a) the response of the EUT includes the CPC sentences with the parameters set according to the CPC input and the Sentence status flag set to “R”. Confirm that each ungrouped output TAG block contains the c: parameter with the correct UNIX time in seconds. Confirm that in each TAG block group at least one TAG block contains the c: parameter with the correct UNIX time in seconds;
- b) a NAK is output on the PI as a response to the CPC indicating that the EUT does not support millisecond resolution for the UNIX time. If no NAK is output then confirm that each ungrouped output TAG block contains the c: parameter with the UNIX time in milliseconds. Confirm that in each TAG block group at least one TAG block contains the c: parameter with the UNIX time in milliseconds. Required accuracy shall be ± 1 s.

10.5.9 Test of Line-count output

10.5.9.1 Purpose

This test verifies the output of the TAG block parameter “n” with the correct line number.

10.5.9.2 Method of measurement

Set up the standard test environment and operate the EUT as defined in the pre-setup conditions.

- a) Enable the Talker Grouping function and disable the Source identification and Destination –identification. Input an SPO sentence to inactivate VSI sentences for VDO. Apply a CPN sentence (Configure Parameter code for the Line-count parameter) with the Talker Line-count function set to „A” (enabled) and the Listener Line-count function set to “V” (disabled). The other parameters shall be set to: Reset event = 0 (use the line-count limit), Initial line-count = 1, Count Increment = 1, Line-count limit = 20, Event offset = null field. Apply a TBR sentence.

The following tests are performed only if the optional functions are implemented.

- b) Apply a CPN sentence with the following parameters: Talker Line-count function enabled Reset event = 0 (use the line-count limit), Initial line-count = 3 000, Count Increment = - 100, Line-count limit = 1 000, Event offset = null field.
- c) Apply a CPN sentence with the following parameters: Talker Line-count function enabled Reset event = 2 (hourly), Initial line-count = 100, Count Increment = 10, Line-count limit = null field, Event offset = 30.

10.5.9.3 Required results

Confirm that:

- a) the response of the EUT includes the CPN sentence with the parameters set according to the CPN input and the Sentence status flag set to “R”. Confirm that each sentence is preceded by a TAG block. Confirm that each TAG block including each TAG block of a group contains an “n” -parameter. Confirm that the line-count is incremented for each occurrence by one. Confirm that the line-count is reset to 1 when it would exceed the line-count limit;
- b) each sentence is preceded by a TAG block containing an “n” parameter. Confirm that the line-count starts with 3 000. Confirm that the line-count is decremented for each occurrence by 100. Confirm that the line-count is reset to 3 000 when it would be less than the line-count limit of 1 000;
- c) each sentence is preceded by a TAG block containing an “n” parameter. Confirm that the line-count starts with 100. Confirm that the line-count is incremented for each occurrence by 10. Confirm that the line-count is reset to 100 30 s after beginning of each hour.

10.6 Test of optional functions

10.6.1 Test of external synchronization source

10.6.1.1 Purpose

This test will verify that the Base Station will operate as required with an external UTC synchronisation source. This test will also verify synchronization jitter.

10.6.1.2 Method of measurement

Set up the standard test environment and operate the EUT as defined in the pre-setup conditions.

- a) Apply the external UTC source to the Base Station.

Apply multiple pairs of a TSA sentence and a VDM sentence with encapsulated Message 8 to the EUT:

```
$xxTSA, <UI>,7,B, <UTC h+m>,<Txslot>,2
!xxVDM,1,1,7,B,8h3OHqh0J7ps?3qv,0
```

The following tests are required for a Base Station operated as an independent unit.

- b) Apply the independent mode setup to the EUT. Apply the external UTC source to the Base Station.

10.6.1.3 Required results

Confirm that:

- a) the EUT is transmitting Message 8 in the assigned slot and channel. Verify synchronization jitter does not exceed $\pm 52 \mu\text{s}$ as required for UTC direct. Confirm that the ADS sentences indicate the correct Sync. State and alarm status.

The following results are required for a Base Station operated as an independent unit.

- c) The Sync. State of the Message 4(s) is 0, indicating UTC direct. Verify synchronization jitter does not exceed $\pm 52 \mu\text{s}$ as required for UTC direct. Confirm that the ADS sentences indicate the correct Sync. State and alarm status.

10.6.2 Test of Message 17 based on RTCM 10402 input

10.6.2.1 Purpose

This test will verify that the Base Station is capable of transmitting Message 17 based on input of RTCM 10402 format on a dedicated port.

10.6.2.2 Method of measurement

10.6.2.2.1 General

The following tests are required for a Base Station operated as an independent unit.

Set up the standard test environment and operate the EUT as defined in the pre-setup conditions.

- a) Apply the independent mode setup to the EUT:
- b) Define a transmission schedule for Message 17 with a reporting interval of 10 s using an ECB sentence:
\$xxECB,<UI>,17,0,10,750,2,0,385,750,2,C
- c) Apply correction data in RTCM 10402 format on a dedicated port for a period of at least 1 min.
- d) Discontinue the input of correction data.
- e) Disable the transmission schedule for Message 17 using an ECB sentence like the following sentence:
\$xxECB,<UI>,17,0,-1,,0,-1,,C
- f) Apply correction data in RTCM 10402 format on a dedicated port for a period of at least 1 min.

10.6.2.2.2 Required results

The following results are required for a Base Station operated as an independent unit.

Confirm that:

- a) the Independent mode setup has been correctly set;
- b) the ECB sentence was received correctly by the EUT using the query sentence for the ECB sentence;
- c) the EUT is transmitting Message 17 over the VDL in the specified slots, intervals and channels as defined by the ECB. Confirm the content of Message 17 is the most current and as defined by the RTCM 10402 data. Confirm that the appropriate VDO sentence is output on the PI when a message is transmitted;
- d) the EUT continues transmitting Message 17 over the VDL for 1 min then stops transmission;
- e) the ECB sentence was received correctly by the EUT using the query sentence for the ECB sentence;
- f) the EUT does not transmit Message 17 over the VDL.

Annex A (normative)

AIS Base Station sentences

A.1 General

This annex describes details of sentences used with the AIS Base Station.

NOTE Refer to IEC 61162-1 for possible later versions of these sentences.

A.2 ACM – AIS Base Station addressed channel management command

This sentence is used to provide an AIS Base Station with the information it uses to transmit an addressed VDL Message 22. This contains settings that are transmitted to one or two specified AIS station(s). Upon receiving this sentence, the Base Station should prepare and make the appropriate transmission (see ITU-R M.1371, Message 22.). This is a command sentence.

This sentence cannot be queried.

\$--ACM,xxxxxxxx,xxxxxxxx,xxxx,x,xxxx,x,x,x,x,a*hh<CR><LF>

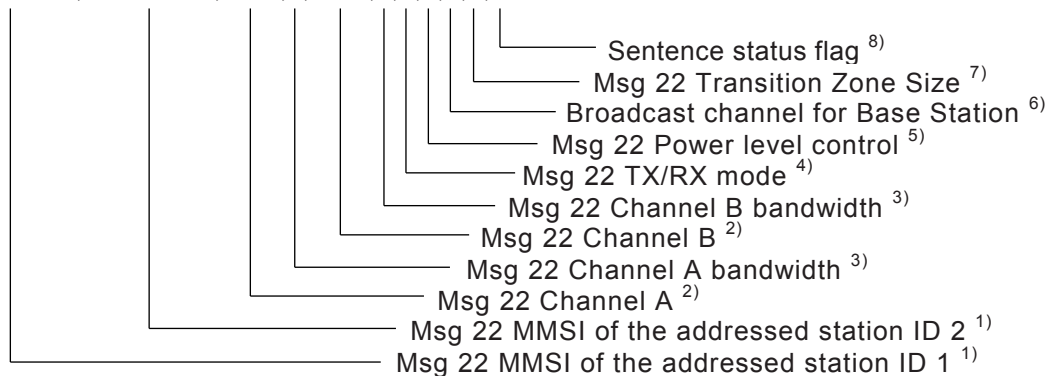

- 1) Identifies the distant addressed AIS unit(s) intended to receive the ITU-R M.1371 Message 22. The first MMSI field (field 1) identifies the first AIS unit. The second MMSI field (field 2) identifies the second AIS unit, and may be set to null if only one AIS unit is being addressed.
- 2) VHF channel number, see ITU-R Recommendation M.1084, Annex 4.
- 3) See ITU-R M.1371 Message 22
0 = bandwidth is specified by channel number, see ITU-R M.1084, Annex 4
1 = bandwidth is 12.5 kHz
- 4) See ITU-R M.1371 Message 22
0 = transmit on channels A and B, receive on channels A and B
1 = transmit on channel A, receive on channels A and B
2 = transmit on channel B, receive on channels A and B
- 5) See ITU-R M.1371 Message 22
0 = high power
1 = low power

- 6) The field identifies the channel that the Base Station should use to broadcast the ITU-R M.1371 Message 22. This field should not be a "null" field.

0 = No broadcast channel preference

1 = broadcast on AIS channel A

2 = broadcast on AIS channel B

3 = broadcast on both AIS channel A and AIS channel B

- 7) Range of 1 NM to 8 NM. This should take into consideration the transition zone size for the area in which the specified AIS station(s) are located.

- 8) This field is used to indicate a sentence that is a status report of current settings or a configuration command changing settings. This field shall not be null.

R = Sentence is a status report of current settings.

C = Sentence is a configuration command to change settings. A sentence without "C" is not a command.

A.3 ADS – Automatic device status

This sentence is used to output, autonomously and periodically, the device's current status of the time source and time synchronization method, position source, and the general alarm state of the device. The ADS sentence is output at the defined interval or when there is a change in status. The equipment standard or manufacturer's documentation should identify the status values supported.

The individual equipment standards are responsible for defining the alarm conditions under which the alarm status is active or not active.

When this sentence is used with AIS Base Stations, the interval for automatic output of this sentence is defined using the BCG sentence, and null data fields are not allowed.

\$--ADS,c--c,hmmss.ss,a,x,a,a*hh<CR><LF>

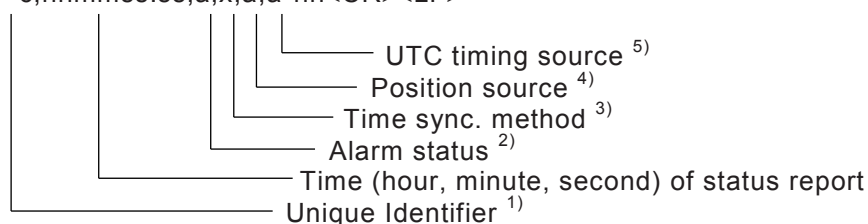

- 1) The Unique Identifier is used for system level identification of a station, 15 characters maximum. When used with AIS stations, on output, this data field is the AIS Station's Unique Identifier (see the SID sentence formatter). For devices other than AIS Base Stations this field may be null.

- 2) Alarm status:

A = active

V = not active

- 3) Method of time synchronization

0 = UTC direct

1 = UTC indirect (AIS equipment)

2 = synchronized to an AIS Base Station

3 = semaphore (AIS equipment)

4 = no VDL synchronization reference (AIS equipment)

5 = manual

6 to 9 = reserved for future use

- 4) I = internal

E = external
S = surveyed
N = none

- 5) E = external
I = internal
N = none

A.4 AGA – AIS Base Station broadcast of a group assignment command

This sentence is used to provide an AIS Base Station with information it uses to broadcast a “group assignment Message 23”. Upon receiving this sentence, the Base Station should prepare the content of a Message 23. Broadcast scheduling for Message 23 is defined using an ECB sentence. This is a command sentence.

\$--AGA,c--c,x.x,xxx,IIII.II,a,yyyyy.yy,a,IIII.II,a,yyyyy.yy,a,xx,x,xx,a*hh<CR><LF>

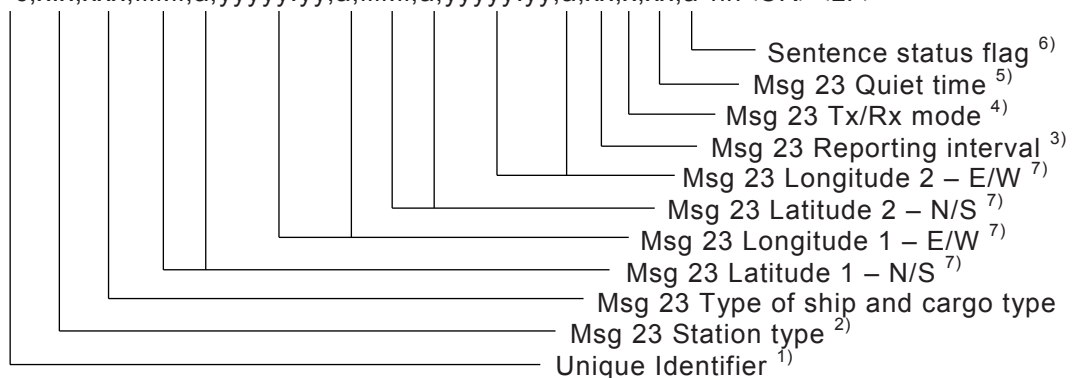

- 1) The Unique Identifier is used for system level identification of a station, 15 characters maximum. (See the SID Sentence). On input, this sentence should be accepted only if this data field matches the Base Station's Unique Identifier. On output, this data field is the Base Station's Unique Identifier.
- 2) The field identifies the group of mobile stations for the group assignment.
- 0 = all types of mobiles (default)
 - 1 = Class A mobile station only
 - 2 = all types of Class B mobile stations
 - 3 = SAR airborne mobile station
 - 4 = Class B “SO” mobile stations only
 - 5 = Class B “CS” shipborne mobile station only
 - 6 = Inland waterways
 - 7-9 = for regional use
 - 10 = This sentence defines a Base Station coverage area with respect to ITU Message 27 broadcasts for Class A and Class B “SO” mobile stations (see ITU 1371 Message 4 and Message 27).
 - 11-15 = for future use
- 3) The field identifies the reporting interval as defined in Table 17 of IEC 62287-1:2010.
- 0 = as given by the autonomous mode
 - 1 = 10 min
 - 2 = 6 min
 - 3 = 3 min

- 4 = 1 min
 - 5 = 30 s
 - 6 = 15 s
 - 7 = 10 s
 - 8 = 5 s
 - 9 = next shorter reporting interval
 - 10 = next longer reporting interval
 - 11 = 2 s (not applicable to class B CS)
 - 12-15 = reserved for future use
- 4) This is the parameter sent in a Message 23. (See “TX/RX Mode” parameter, ITU-R M.1371 Message 23)
- 0 = transmit on channels A and B, receive on channels A and B (default)
 - 1 = transmit on channel A, receive on channels A and B
 - 2 = transmit on channel B, receive on channels A and B
 - 3 = reserved for future use
- 5) 0 = no quiet time (default)
- 1-15 = quiet time 1 min to 15 min
- 6) This field is used to indicate a sentence that is a status report of current settings or a configuration command changing settings. This field should not be null.
- R = Sentence is a status report of current settings (used for a reply to a query).
 - C = Sentence is a configuration command to change settings. A sentence without “C” is not a command.
- 7) The resolution of the latitude and longitude fields shall be fixed at 1 decimal place of minutes (1/10 of a minute). If a higher resolution is provided to an AIS unit, the receiving AIS unit shall truncate to 1/10's of minute.

A.5 ASN – AIS Base Station broadcast of assignment command

This sentence is used to provide an AIS Base Station with the information it uses to broadcast an “assignment VDL Message 16”. This contains settings that are broadcast to the specified AIS station(s). Upon receiving this information, the Base Station should prepare and make the appropriate broadcast (see ITU-R M.1371, Message 16). This is a command sentence.

This sentence cannot be queried.

```
$--ASN,xxxxxxxx,x.x,x.x,x.x,xxxxxxxx,x.x,x.x,x.x,a*hh<CR><LF>
```

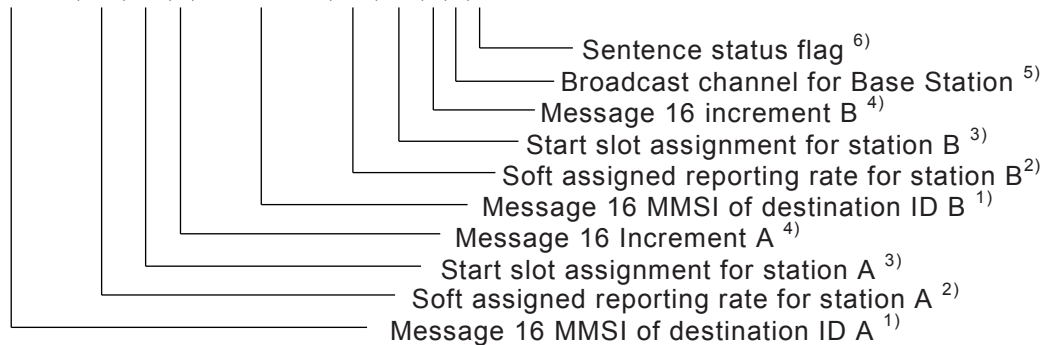

- 1) Identifies the distant addressed AIS unit(s) for the VDL assignment. The first set of four fields apply to a single AIS unit, while the second set of four fields (fields 5 – 8) apply to a second AIS unit. When only one AIS unit's assignment schedule is being provided, the second set of four fields (fields 5 – 8) may be set to null.
- 2) This field corresponds to the ITU-R M.1371 Message 16 Offset field. The Base Station will only use this field if the “increment for AIS” field (fields 4 and 8 of this sentence) for the same AIS unit is set to zero. The range of values for this field consists of multiples of 20, between and including 20 to 600. Values that are less than 600 but are not multiples of 20 will be interpreted as the next higher multiple of 20. Values above 600 will be interpreted as 600. This field should be set to null when the “increment for AIS” field (fields 4 and 8 of this sentence) for the same AIS unit is set to a non-zero value.
- 3) When the increment field is non-zero, this field is the start slot for assigned reports. The Base Station should provide the proper Message 16 off-set at time of broadcast to accomplish this assignment. The Base Station calculates the Message 16 “off-set” as the difference of this start slot and the slot of the broadcast. The range of values for this field consists 0 to 2 249 in units of slots. This field should be set to null when the “increment for AIS” field (fields 4 and 8 of this sentence) for the same AIS unit is set to a zero value.
- 4) This field identifies the increment parameter in units of slots for the associated values of this field. The range of values is from 0 to 6. Note that a value of zero does not provide an increment, see 2) above. This field should not be set to null, unless the entire four field set for this AIS unit is not provided, because the Base Station may invoke two distinctly different assignment methods based on a zero or non-zero value. The values and their meanings are:
 - 0 = Reporting rate is based upon the “soft assigned reporting rate for same AIS unit” (fields 2 and 6)/10 min
 - 1 = 1 125 slots
 - 2 = 375 slots
 - 3 = 225 slots
 - 4 = 125 slots
 - 5 = 75 slots
 - 6 = 45 slots
- 5) The field identifies the channel that the Base Station should use to broadcast the ITU-R M.1371 Message 16. A null value in this field indicates no change from previously received values when this sentence is sent to a Base Station and indicates unknown when this sentence is received from a Base Station. The values and their meanings for this are:
 - 0 = no broadcast channel preference

1 = broadcast on AIS channel A

2 = broadcast on AIS channel B

- 6) This field is used to indicate a sentence that is a status report of current settings or a configuration command changing settings. This field should not be null.

R = Sentence is a status report of current settings.

C = Sentence is a configuration command to change settings. A sentence without "C" is not a command.

A.6 BCG – Base Station configuration, general command

This sentence and the BCL sentence are used to configure the Base Station parameters when the Base Station is installed and during operation. This sentence is also used to select the UTC synchronization source to be used by the Base Station. (See also ADS sentence).

\$--BCG,c--c,xxxx,xxxx,xxxx,xxxx,x,x,x,x,a,a,x.x,aa,a*hh<CR><LF>

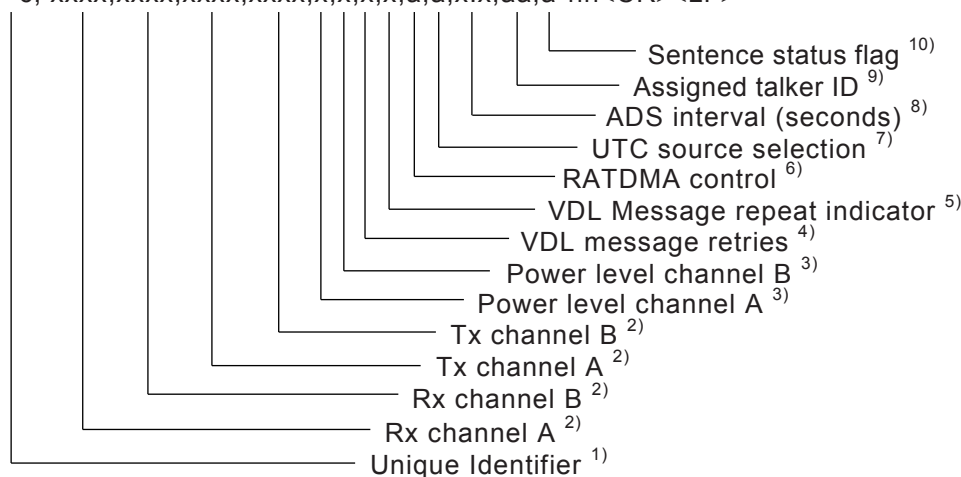

- 1) The Unique Identifier is used for system level identification of a station, 15 characters maximum. (See SID Sentence). On input, this sentence should be accepted only if this data field matches the Base Station's Unique Identifier. On output, this data field is the Base Station's Unique Identifier.
- 2) VHF channel number, see ITU-R M.1084, Annex 4.
- 3) 0 = high power (Nominal 12,5 W)
1 = low power (Nominal 2 W)
2 to 8 reserved for future use
9 = transmission disabled (zero W), this is the default power-up state.
- 4) This is the number of automatic retries for addressed messages. An AIS station may automatically re-broadcast up to three retries. An addressed message is automatically re-broadcast if an AIS station does not receive the required acknowledgement.
0 = do not automatically re-broadcast addressed messages.
1 = limit automatic re-broadcast to one retry
2 = limit automatic re-broadcast to two retries
3 = permitted to use the maximum number of three automatic re-broadcasts = default
- 5) This is the VDL message parameter "Repeat indicator" (RI). This is used to indicate how many times a message has been repeated. See message content tables in ITU-R M.1371. This is the RI for messages generated by the base station. Separate rules apply for repeated messages or VDM input messages. See the applicable equipment standard.
0 = default, broadcast messages may be repeated

1 or 2 = based on overall system design, may reduce number of times VDL broadcasts are repeated

3 = “do not repeat anymore”

- 6) Controls the Base Station’s ability to use RATDMA access to the VDL:

0 = off (Base Station cannot use RATDMA access to VDL)

1 = on (Base Station may use RATDMA access to VDL)

- 7) Controls the UTC synchronization source used by the Base Station:

E = external UTC source

I = internal UTC source

X = external UTC source with fallback to internal UTC source

Y = internal UTC source with fallback to external UTC source, if available

- 8) The default interval is 60 s. The valid range is 1 s to a maximum defined (3 600 s). This data field sets the interval between the output of AIS device status sentences (see ADS sentence). The ADS will also be provided when there is a change in status.

- 9) The default Base Station talker identifier should be set to the primary design of the equipment. Equipment designed to IEC 62320-1 should have a default of AB.

U# (0 ≤ # ≤ 9) = user configured talker identifier: An assigned talker identifier (U0 through U9) does not convey the nature of the device transmitting the sentence, and should not be “fixed” into a unit at manufacturing. This is intended for special purpose applications. The “U#” talker identifier indicates that the device’s default talker identifier has been changed through external control.

- 10) This field is used to indicate a sentence that is a status report of current settings or a configuration command changing settings. This field should not be null.

R = Sentence is a status report of current settings (use for a reply to a query).

C = Sentence is a configuration command to change settings. A sentence without “C” is not a command.

A.7 BCL – Base Station configuration, location command

This sentence and the BCG sentence are used to configure the static Base Station parameters when it is initially installed, and later in order to make changes to the way it operates. Dynamic parameters (e.g. UTC and position of a moving Base Station) are input in a different way. This sentence supports system administration of the AIS Base Station operation.

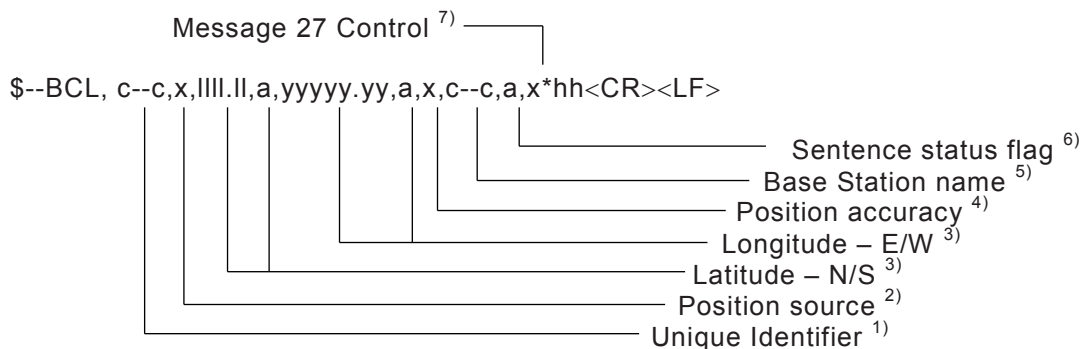

- 1) The Unique Identifier is used for system level identification of a station, 15 characters maximum. (See SID sentence). On input, this sentence should be accepted only if this data field matches the Base Station’s Unique Identifier. On output, this data field is the Base Station’s Unique Identifier.

- 2) Identifies the source of the position:

0 = surveyed position (should always be used for Fixed AIS Base Station)

1 = internal EPFD in use

2 = external EPFD in use

3 = internal EPFD in use with automatic fall back to surveyed position

4 = internal EPFD in use with automatic fall back to external EPFD upon failure of internal EPFD

5 = external EPFD in use with automatic fall back to surveyed position

6 = external EPFD in use with automatic fall back to internal position source upon failure of external position source

Position sources 1, 2, 4 or 6 use automatic fall back to invalid position (181° Longitude and 91° Latitude)

When external EPFD is used (position sources 2, 4, 5 and 6), type of electronic position fixing device is provided by talker ID of the EPFD.

3) Surveyed position of the Base Station.

4) 0 = low >10 m

1 = high <10 m; differential mode of DGNS

5) This is the VDL Message 24, part A, Name: range 0 to 20 alphanumeric characters. The characters that can be used in the name are listed in the ITU-R 1371 6-bit ASCII table. Some of these characters are reserved characters. If reserved characters are used, they should be represented using the "A" method. A null field indicates that the previously entered name is unchanged. The string of characters "@@@@@@@@@@@@@@@@@@" is used to indicate that the name is not available.

6) This field is used to indicate a sentence that is a status report of current settings or a configuration command changing settings. This field should not be null.

R = Sentence is a status report of current settings (use for a reply to a query).

C = Sentence is a configuration command to change settings. A sentence without "C" is not a command.

7) 0 = Class A and Class B "SO" mobile stations stops transmission of Message 27 within an AIS base station coverage area.

1 = Request Class A and Class B "SO" mobile stations to transmit Message 27 within an AIS base station coverage area.

A.8 DLM – Data link management slot allocations for Base Station command

This sentence provides the Base Station with the slot allocations to be reserved for FATDMA Base Station broadcasts. This sentence provides the Base Station with the information necessary to broadcast an ITU-R M.1371 Message 20 Data link management message, which informs mobile AIS units of the reserved FATDMA slots. Upon receipt of this sentence the Base Station will reserve the provided FATDMA slot allocations within its frame map, and will be ready to generate Message 20 when instructed to do so via the ECB sentence. This is the information that is broadcast on the VDL using Message 20. Reference ITU-R M.1371 (Also, see ECB sentence).

The FATDMA slot reservations are determined using a set of 5 DLM data fields – Ownership, Start, Number, Time, and Increment. Each DLM sentence supports four sets of FATDMA slot reservation parameters.

The AIS Base Station, upon receipt of a query for this sentence, will generate a response to the requestor consisting of 20 DLM sentences containing all the FATDMA slot reservation parameters (set). When a set is empty (not defined or cleared), all 5 data fields of the set are returned as null.

The shore station is responsible for filtering out slot reservation conflicts that may exist. The Base Station is not responsible for detecting these conflicts. These conflicts in the shore station network should be resolved separately from entering the data.

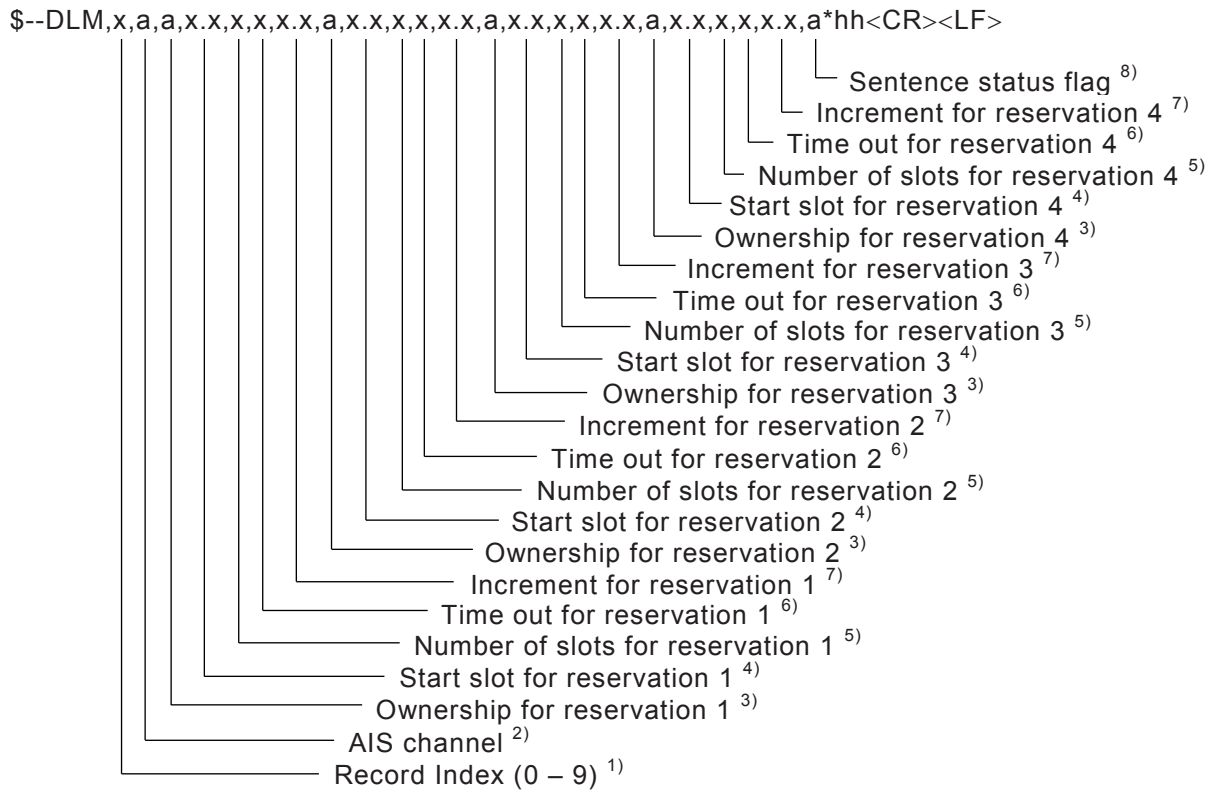

1) The Record Index is used to identify and address each record of DLM sentence data. A maximum of 10 records can be stored for each AIS channel. The Record Index is used to associate the DLM sentence data with each VDL Message 20 broadcast by the Base Station.

2) The AIS channel defines the broadcast channel. This cannot be a null field.

A = Channel A

B = Channel B

3) This field identifies the ownership of the reservation. Possible values are as follows:

L = Local ownership. The Base Station receiving this sentence owns and may utilize these FATDMA slots. The Base Station should broadcast these FATDMA slot reservations.

R = Remote ownership Remote AIS Stations own and may use these FATDMA slots. The Base Station should transmit these FATDMA slot reservations.

C = Clear the reservation. This instructs the Base Station receiving this sentence to clear this reservation from its frame map. If this field is set to "C", then the following four data fields (Start, Number, Time, and Increment) should be set to null, and will be ignored if set otherwise.

First reservation "ownership" – indication of shore station ownership for each set of slot reservations; "L" for local, "R" for remote. A Base Station should transmit slot reservations for remote (R) stations. The Base Station is not allowed to use the slots reserved for remote (R) stations unless commanded to do so by use of TSA+VDM pairs. The Base Station is allowed to broadcast on local (L) slots. Final slot selection is a process internal to the Base Station.

4) Start slot range: 0 to 2 249. A null field indicates no change to the starting slot for this FATDMA reservation.

5) Number of slots range: 1 to 5 (consecutive slots reserved for FATDMA broadcasts). A null field indicates no change to the number of consecutive slots reserved when sent to the AIS equipment.

6) Time out range in minutes: 0 to 7. A null field indicates no change to the Time out when sent to the AIS equipment.

7) Increment range: 0 to 1 125 in slots. A value of 0 indicates one reservation block in the frame. A null field indicates no change to the current slot increment setting when sent to the AIS equipment. When the increment is not "0" the following formula should apply to ensure the periodical slot reservation from frame to frame (see ITU-R M.1371, Message 20): $2\ 250 \bmod \text{increment} = 0$

- 8) This field is used to indicate a sentence that is a status report of current settings or a configuration command changing settings. This field should not be null.

R = Sentence is a status report of current settings (use for a reply to a query).

C = Sentence is a configuration command to change settings. A sentence without “C” is not a command.

A.9 ECB – Configure broadcast schedules for Base Station messages, command

This sentence assigns the schedule of slots that will be used to broadcast the specified Message: 4, 17, 20, 22, 23, or 24. It provides the start slot and interval between the slots used for consecutive transmissions for the message. The interval span supports creation of broadcast schedules based upon a 6 min FATDMA epoch. The AIS Base Station should apply the information provided by this sentence to autonomously and continuously transmit the VDL message indicated until revised by a new ECB sentence.

CAUTION The interval span in this sentence supports FATDMA planning where 6 min epochs are used. When planning the FATDMA use of VDL slots, time can be organized into 6 min periods identified using FATDMA “epoch numbers” (0 to 9). The start of a FATDMA epoch is correlated with the beginning of the hour. A FATDMA epoch starts with the first second of the first minute, and ends with the end of last second of the sixth minute of the epoch. The FATDMA epoch number of each FATDMA epoch in 1 h is correlated to an absolute start minute within the hour (FATDMA epoch number × 6). For example, FATDMA epoch “0” is minute 0 through 5, and FATDMA epoch “9” is minute 54 through 59.

The AIS Base Station, upon receipt of an ECB query for this information, will generate a sentence for each Message type (4, 17, 20, 22, 23, and 24) providing the current broadcast schedule. The reply also reports Messages (4, 17, 20, 22, 23, and 24) not scheduled.

A new ECB assignment for a message will override the existing ECB assignment.

`$--ECB,c--c,x.x,x.x,x.x,x.x,x.x,x.x,x.x,x.x,x.x,x.x,x.x,a*hh<CR><LF>`

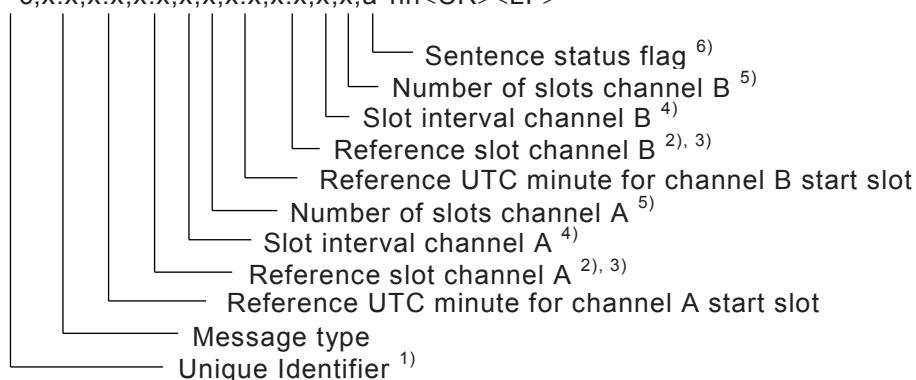

- 1) The Unique Identifier is used for system level identification of a station, 15 characters maximum. (See SID sentence). On input, this sentence should be accepted only if this data field matches the Base Station's Unique Identifier. On output, this data field is the Base Station's Unique Identifier.
- 2) For Message 4, starting slot ranging from –1 to 749 should be used. The broadcasts should alternate between the channels A and B. The increment may vary; see ITU-R M.1371-1, Annex 1, 4.2.1, Table 1B and footnote 1 for details. A value of –1 discontinues broadcasts of Message 4 when the ECB sentence is sent to the Base Station, and indicates that Message 4 has been turned off if the ECB sentence is received from the Base Station. A null field indicates no change to the current start slot setting when sent to the Base Station, and indicates that the start slot has not been set when the ECB sentence is received from the Base Station.
- 3) For Messages 17, 20, 22, 23, or 24, starting slot ranging from –1 to 2 249 should be used.

When the ECB sentence is sent to the Base Station, a value of –1 clears the schedule and discontinues broadcasts for the indicated message. When the ECB sentence is received from the Base Station, a value

of –1 indicates that no message is scheduled for broadcast. When the ECB sentence is sent to the Base Station, a null field indicates no change to the current start slot setting. When the ECB sentence is received from the Base Station, a null field indicates the start slot has not been set.

- 4) Slot interval ranging from 0 to 13 500 in slots (epoch of 6 min) , between broadcasts of ITU-R M.1371 Messages 17, 20, 22, 23, or 24 on channels “A” or “B”. Interval selection for Message 17 should consider the timing needs for both DGNSS corrections and integrity warnings. 5 s or less is recommended.

A value of 0 indicates only one broadcast.

A null field indicates no change to the current slot interval setting when sent to the Base Station, and indicates that the slot interval has not been set, i.e. is unavailable, when the ECB sentence is received from the Base Station.

When the value is 1 to 2 249, the interval (i) should satisfy the formula: $2\,250 \bmod i = 0$ to ensure the slot schedule is periodic from frame to frame.

When the value is greater than 2 249 the only permissible intervals are 2 250, 4 500, 2 675, and 13 500.

When neither of these conditions are satisfied, the sentence should be rejected if the remainder is not zero and a “NAK (11)” may be returned.

- 5) For messages other than Message 17, this field is null. For Message 17, the number may range from 1 to 4 consecutive slots. A maximum of 3 slots is recommended for each DGNSS service.

A null field indicates no change to the number of consecutive slots reserved when sent to the Base Station, and indicates that the number of consecutive slots has not been set, i.e. is unavailable, when the ECB sentence is received from the Base Station.

- 6) This field is used to indicate a sentence that is a status report of current settings or a configuration command changing settings. This field should not be null.

R = Sentence is a status report of current settings (use for a reply to a query).

C = Sentence is a configuration command to change settings. A sentence without “C” is not a command.

A.10 FSR – Frame summary of AIS reception

This sentence provides for one AIS channel: the average noise level and a summary of slot use during the previous frame, and expected slot use for the current frame. The sentence is output once at the start of the current frame, as shown in Figure A.1.

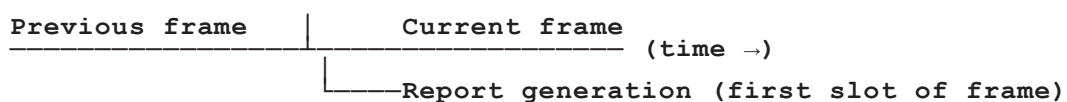
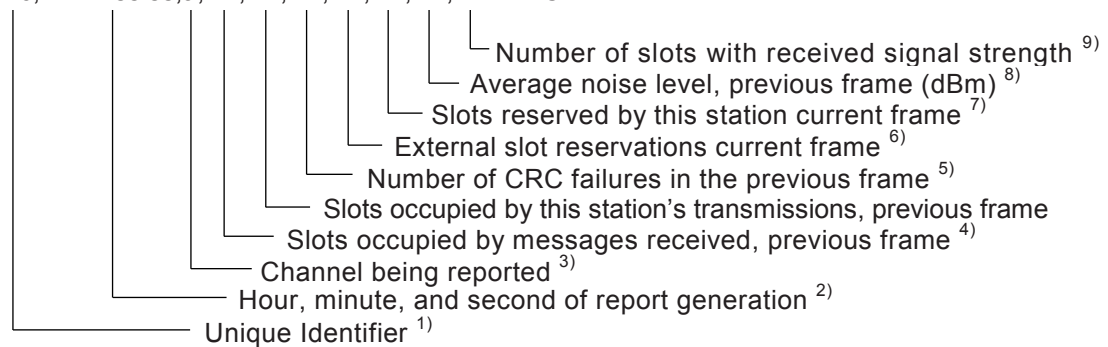

Figure A.1 – Frame summary timing

Data fields 4 through 10 are enabled using data fields in the SPO sentence. If a data field is not enabled, the data field should contain the “null field” notation for no information.

\$--FSR,c--c,hhmmss.ss,a,x.x,x.x,x.x,x.x,x.x,x.x,x.x*hh<CR><LF>



- 1) The Unique Identifier is used for system level identification of a station, 15 characters maximum. (See SID sentence). On output, this data field is the Base Station's Unique Identifier.
- 2) The time (UTC) when this sentence is assembled. This sentence is assembled at the beginning of a frame (see Figure A.1).
- 3) A = channel A
B = channel B
- 4) Exclude slots occupied by this station's transmissions.
- 5) This count includes all cases where an AIS signal is detected but fails the Cyclic Redundancy Check (CRC).
- 6) Total external slot reservations, including FATDMA reservations. Exclude slots reserved by this station. The calculation of the current frame's slot reservations should be done during the first slot. The total should not include additional reservations made for slots in the current frame by messages received during the current frame.
- 7) Total number of reservations for the current frame. Total should not include additional reservations made during the current frame.
- 8) Measured value is always negative. Null when measurement not available
- 9) Number of slots with received signal strength (at least 10 dB) above the average noise level.

A.11 RST – Equipment Reset Command

This sentence is used to restart or reset the equipment.

This sentence cannot be queried.

\$--RST,c--c,x,x,a*hh<CR><LF>

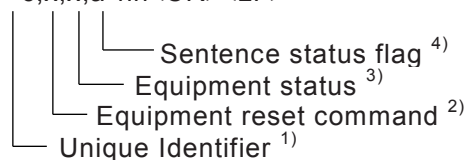

- 1) The Unique Identifier is used for system level identification of a station, 15 characters maximum. When the Unique Identifier is provided, this sentence should be accepted only if this data field matches the equipment's Unique Identifier.
- 2) This field restarts equipment operation or resets equipment settings. Null indicates no action taken.
 - 1 = This commands the equipment to restart operation using the current values for all configurable settings.
 - 2 = This commands the equipment to reset all configurable settings to the default factory values.
- 3) This field reports completion of the equipment restart or reset.
 - 1 = equipment restart using the current values for all configurable settings.

2 = equipment reset all configurable settings to the default factory values.

3 = unexpected restart using the current values for all configurable settings (no RST command).

4 = unexpected reset all configurable settings to the default factory values (no RST command).

5 to 9 reserved for future use.

- 4) This field is used to indicate a sentence that is a status report of current settings or a configuration command changing settings. This field should not be null.

R = Sentence is a status report of current settings.

C = Sentence is a configuration command to change settings. A sentence without "C" is not a command.

A.12 SID – Set an equipment’s identification and command

This sentence is used to configure an equipment’s Unique Identifier and/or MMSI. The Unique Identifier is used for system level identification. The MMSI is used to identify the AIS station on the VHF Data Link.

The Current Unique Identifier is required to change the Base Station’s Unique Identifier. The Current MMSI is not required to change the Unique Identifier.

The Current Unique Identifier and the Current MMSI are required to change the MMSI.

Proper installation of a Base Station’s Unique Identifier and MMSI may be confirmed by using a query.

This sentence may be used for other equipment beside AIS Base Station.

`$--SID,c--c,c--c,xxxxxxxx,xxxxxxxx,a*hh<CR><LF>`

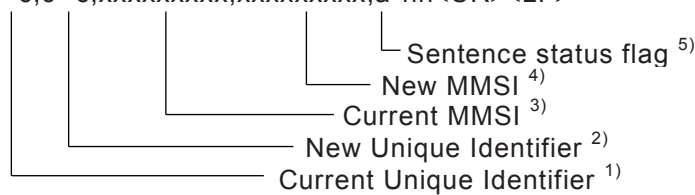

- 1) The Current Unique Identifier is used for system level identification of a station, 15 characters maximum. On input, this sentence should be accepted only if this data field matches the Base Station’s Unique Identifier. On output, this data field is the Base Station’s Unique Identifier.
- 2) The New Unique Identifier data field is used to change the Unique Identifier of the Base Station. If the Unique Identifier is not intended to be changed, this field should be a null field. On output from a Base Station, this data field should be a null field.
- 3) The Current MMSI is a nine-digit number; leading zeros are required. On input, if the MMSI is not being changed, this field should be a null field. On output from the Base Station, this data field is the Base Station’s MMSI.
- 4) The New MMSI data field is used to change the MMSI of the Base Station. If the MMSI is not intended to be changed, this field should be a null field. On output from a Base Station, this data field should be a null field.
- 5) This field is used to indicate a sentence that is a status report of current settings or a configuration command changing settings. This field should not be null.

R = Sentence is a status report of current settings (use for a reply to a query).

C = Sentence is a configuration command to change settings. A sentence without "C" is not a command.

A.13 SPO – Select AIS device's processing and output command

This sentence is used to configure the content and output for measurements made on selected channels during operation of a Base Station or a receiving station. When a data field(s) is selected, the corresponding VSI and/or FSR sentence(s) will be output following the rules for those sentence formatters.

\$--SPO,c--c,a,x,x,x,x,x,x,x,x,x,x,x,x,x,x,a*hh<CR><LF>

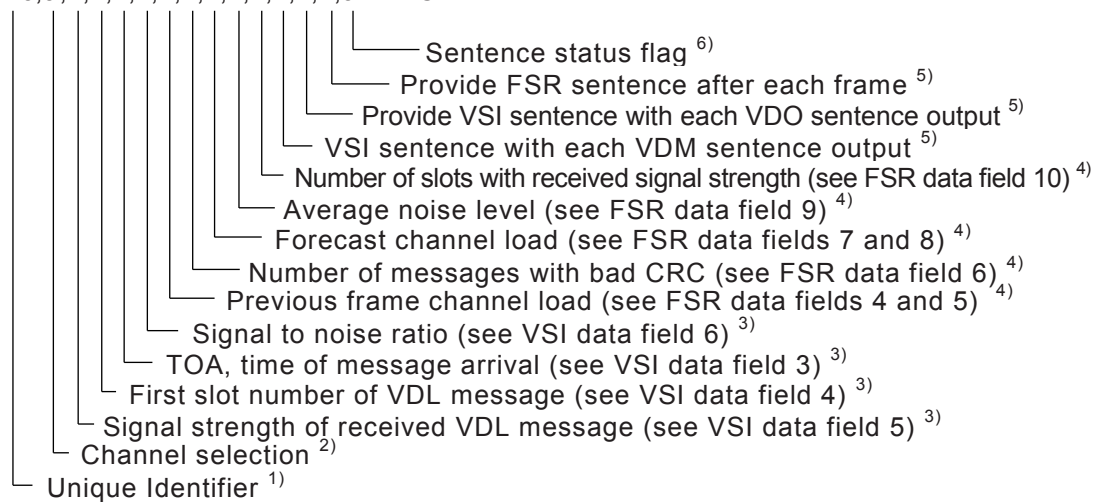

- 1) The Unique Identifier is used for system level identification of a station, 15 characters maximum. (See SID sentence). On input, this sentence should be accepted only if this data field matches the Base Station's Unique Identifier. On output, this data field is the Base Station's Unique Identifier.
- 2) A = channel A
B = channel B
E = every channel
N = no VSI or FSR sentences about any channel
- 3) 0 = no output
1 = continuous output
2 = output next frame only
- 4) 0 = no output
1 = output once per frame
2 = output next frame only
- 5) 0 = off, disabled
1 = on, enabled
- 6) This field is used to indicate a sentence that is a status report of current settings or a configuration command changing settings. This field should not be null.
R = Sentence is a status report of current settings (use for a reply to a query).
C = Sentence is a configuration command to change settings. A sentence without "C" is not a command.

A.14 TFR – Transmit feed-back report

The TFR sentence is automatically generated by the Base Station to report to the physical shore station the scheduled slot use and status of a requested transmission.

Several data fields are copied from the TSA and VDM sentences responsible for this TFR. They are provided to assist in linking this Base Station response to the responsible VDM or TSA/VDM sentence(s).

After receiving associated TSA and VDM sentences, the Base Station responds with a TFR sentence that provides status information about the requested transmission. The VDO+VSI will provide verification of the transmission itself.

After receiving a VDM sentence without an associated TSA sentence (as when requested transmissions are not assigned to a specific starting slot), the Base Station should respond with a TFR sentence.

This sentence cannot be queried.

\$--TFR,x,x,a,c--c,xxxx,x.x,xxxx,x.x,x,x,x.x*hh<CR><LF>

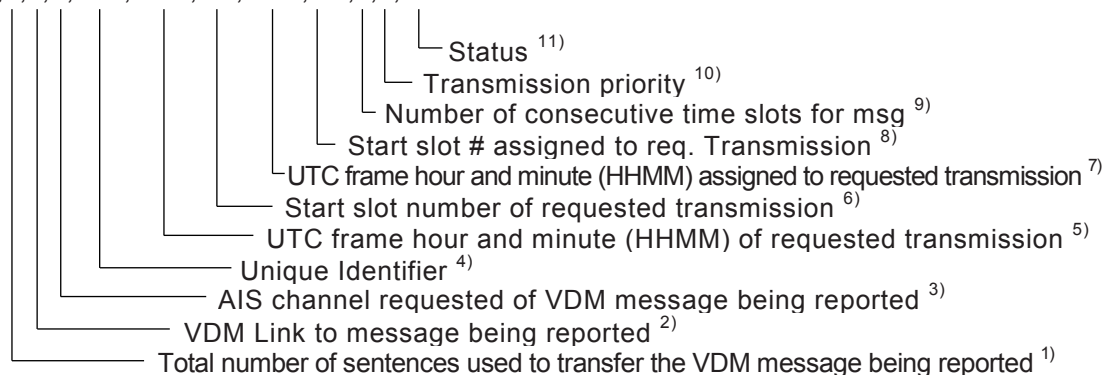

- 1) Exact copy of the first data field of the VDM sentence to which this TFR is responding – “total number of sentences needed to transfer the message.”
- 2) This field is used to link the information in associated VDM sentence(s) with the information in this sentence. This data field contains the same value as the sequential message identifier of the associated VDM sentence(s).
- 3) Actual channel scheduled for the requested transmission. It should be an exact copy of the fourth data field of the VDM sentence to which this TFR is responding – “AIS channel.”
- 4) The Unique Identifier is used for system level identification of a station, 15 characters maximum. (See SID sentence). On output, this data field is the Base Station’s Unique Identifier.
- 5) UTC hour and minute scheduled for the requested transmission. This should be an exact copy of the fourth data field of the TSA sentence to which this TFR is responding – “UTC hour and minute of requested transmission”. This data field should include leading zeros. This is null when there is no TSA sentence with the VDM sentence.
- 6) This should be an exact copy of the fifth data field of the TSA sentence to which this TFR is responding – “start slot number of requested transmission”. This is null when there is no TSA sentence with the VDM sentence.
- 7) UTC hour and minute assigned for the requested transmission. This is determined by the Base Station for a received VDM sentence when no associated TSA sentence is received. This data field should include leading zeros. This is null when associated TSA and VDM sentences are received.
- 8) Start slot number assigned for requested transmission. This is determined by the Base Station for a received VDM sentence when no associated TSA sentence is received. This is null when associated TSA and VDM sentences are received.
- 9) Actual number of slots that are scheduled for the transmission of the requested message. This takes into consideration bit stuffing.

- 10) Priority is either that requested in the TSA sentence or that assigned by the Base Station.
- 1 = high priority
 - 2 = low priority (default value)
- 11) 0 = successfully scheduled for transmission
- 1 = successfully scheduled for transmission by overriding an internal message with a lower priority
 - 2 = successfully scheduled for a transmission time greater than 12 h from the present time
 - 3 = not scheduled because requested transmission exceeded available memory
 - 4 = successfully removed from schedule
 - 5 = not scheduled because requested transmission conflicted with slot(s) requested by an internal Base Station process that has the same or higher priority
 - 6 = not scheduled because requested message type is not allowed by the Base Station configuration
 - 7 = not scheduled because requested message conflict to prohibit slots
 - 8 = configuration error
 - 9 = not scheduled because requested transmission is for a disabled channel
 - 10 = not scheduled because of invalid TSA content (e.g. invalid slot number)
 - 11 = successfully scheduled for transmission by overriding an externally requested message with a lower priority
 - 12 = not scheduled because requested transmission conflicts with previously scheduled transmission with same or higher priority

A.15 TPC – Transmit slot prohibit command

This sentence is used to prohibit an AIS station from transmitting in the specified slots. This sentence is designed to be used by stations, such as AtoN, where the temporary prohibit sentence (see TSP sentence) is inadequate. For an AtoN Station the Unique Identifier is the AtoN Station real MMSI.

This sentence can be queried.

```
$--TPC,c--c,x,x,a,hmmss.ss,x,x,x,x,x,x,x,x,x,x,x,x,x,x,x,x,x,x,x,x,x,a,a*hh<CR><LF>
```

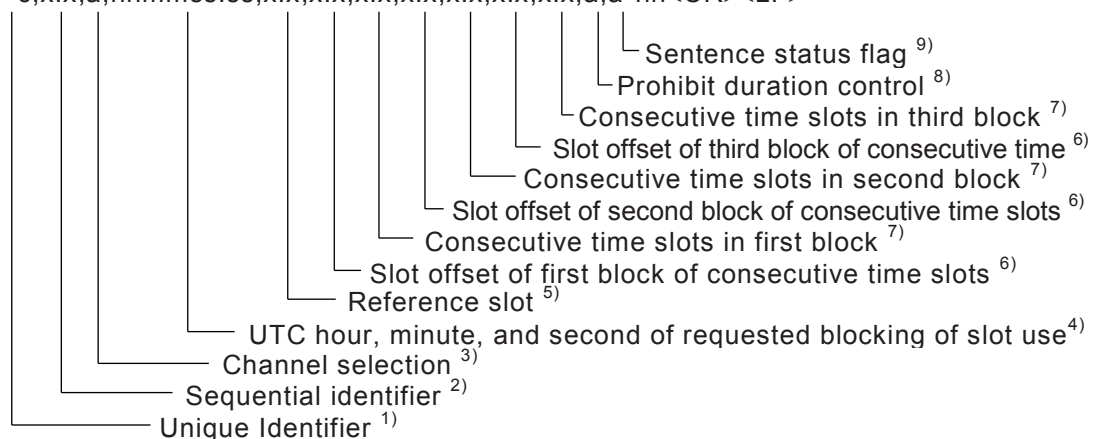

- 1) The Unique Identifier is used for system level identification of a station, 15 characters maximum (see AID sentence). On input, this sentence should be accepted only if this data field matches the AtoN Station's Unique Identifier. On output, this data field is the AtoN Station's Unique Identifier.
- 2) The sequential identifier provides an identification number from 0 to 99 that is sequentially assigned and is incremented for each new TPC sentence. The count resets to 0 after 99 is used. This sequential identifier is

used to identify the AIS station's response to this TPC sentence when the station replies with a slot prohibit status report (see TSR sentence).

- 3) A = channel A
B = channel B
- 4) This is for record keeping. It contains the hour, minute, and second of this request.
- 5) This is the slot from which the following slot offsets are referenced.
- 6) 0 = no prohibited slots
1 to 2 249 = Slot offset from the "Reference slot" to the first slot of the consecutive slots to be blocked from use by the AIS Station.
- 7) Total number of consecutive slots to be blocked from use. The first slot of the block is also part of the count. Therefore, the minimum value is 1.
1-5 = number of prohibited slots
- 8) This field is used to control the prohibited slots. This field should not be null for AIS AtoN Stations.
C = immediately restore for use all slots currently prohibited from use
E = the slot prohibition expires for the slots identified in this sentence after their next occurrence
P = prohibit the use of slots identified in this sentence. Slots are restored for use using "C" or "R"
R = restore the use of slots identified in this sentence.
- 9) This field is used to indicate a sentence that is a status report of current settings or a configuration command changing settings. This field should not be null for AIS AtoN Stations.
R = Sentence is a status report of current settings (use for a reply to a query).
C = Sentence is a configuration command to change settings. A sentence without "C" is not a command.

A.16 TSA – Transmit slot assignment

This sentence is used to provide the AIS Base Station with the information for the broadcast of the VDL message encapsulated in the associated VDM sentence(s) beginning in the specified time slot. The TSA/VDM sentence combination is used for individual message transmissions only. This sentence is only used in combination with a VDM sentence.

This sentence should precede the referenced VDM sentence.

If TAG Blocks are used, the TSA sentence is also linked to the associated VDM sentence(s) using TAG Block "sentence-grouping". A long VDL message may require the use of several VDM sentences.

This sentence cannot be queried.

\$--TSA,c--c,x,a,xxxx,x.x,x*hh<CR><LF>

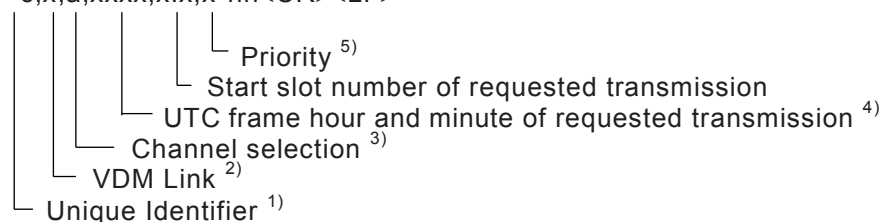

- 1) The Unique Identifier is used for system level identification of a station, 15 characters maximum. (See SID sentence). On input, this sentence and any associated VDM sentence(s) should be accepted only if this data field matches the Base Station's Unique Identifier.

- 2) This field is used to link the information in associated VDM sentence(s) with the information in this sentence. This data field contains the same value as the sequential message identifier of the associated VDM sentence(s).
- 3) This should be the same channel as indicated in the associated VDM sentence(s).
- A = channel A
- B = channel B
- 4) Identification of slot frame for the start slot number. Format is HHMM (hours, minutes) in the range 0000 to 2359. When null, the start slot number is for the next occurrence of the slot.
- 5) 0 = cancel the scheduled transmission identified by the Channel selection, UTC frame hour and minute, and Start slot number.
- 1 = high priority, should overrule internal Base Station schedule. It may not interfere with multi-slot transmissions already in progress.
- 2 = low priority, will transmit if slot is available
- 3 to 9 reserved for future use.
- Default is priority 2

A.17 TSR – Transmit slot prohibit status report

This sentence is automatically generated to report the results of a TSP sentence.

This sentence cannot be queried.

\$--TSR,c--c,x,x,a,hhmmss.ss,x,x*hh<CR><LF>

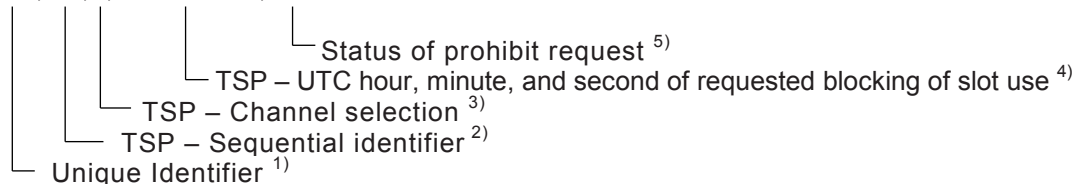

- 1) The Unique Identifier is used for system level identification of a station, 15 characters maximum. (See SID sentence). On output, this data field is the Base Station's Unique Identifier.
- 2) Exact copy of the second data field (sequential identifier) provided in the TSP sentence to which this TSR is responding. It is an identification number from 0 to 99 that is sequentially assigned and is incremented for each new TSP sentence. The count resets to 0 after 99 is used. This sequential identifier is used to identify the Base Station's TSR transmit slot prohibit status report.
- 3) Exact copy of the third data field (channel selection) provided in the TSP sentence to which this TSR is responding.
- A = channel A
- B = channel B
- 4) Exact copy of the fourth data field (hour, minute, and second) provided in the TSP sentence to which this TSR is responding.
- 5) 0 = successfully blocked prohibited slots
- 1 = not successful because of internal reservation
- 2 = not successful because action is not allowed by the Base Station configuration
- 3 = not successful because action is for a disabled channel
- 4 = not successful because of invalid TSA content (e.g. invalid slot number)

A.18 VSI – VDL signal information

This sentence provides measurement information associated with a VDL message. This sentence is also used to identify the first slot of a VDL message. This sentence is only used in combination with either a VDM or VDO sentence. This sentence should follow the referenced VDM or VDO sentence.

The measurement data fields of this sentence are enabled using the SPO sentence.

This sentence cannot be queried.

\$--VSI,c--c,x,hhmmss.ss,x.x,x.x,x.x*hh<CR><LF>

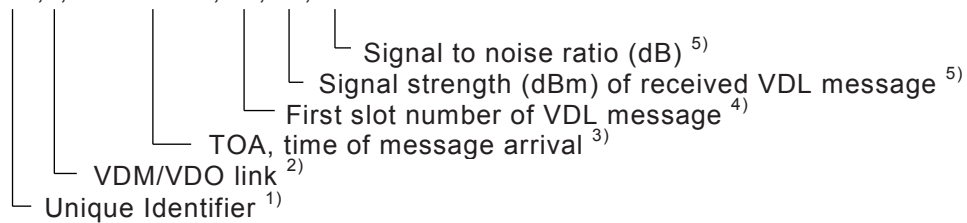

- 1) The Unique Identifier is used for system level identification of a station, 15 characters maximum. (See SID sentence). On output, this data field is the Base Station's Unique Identifier.
- 2) This field is used to link the information in either an associated VDM or VDO sentence(s) with the information in this sentence. This data field contains the same value as the sequential message identifier of the associated VDM or VDO sentence(s).
- 3) This is the UTC hour, minute, and second and decimal fraction of second measurement for when an AIS message signal is received. When the decimal fraction portion of this measurement is provided, the precision may be given to 1 ns.
246060 = requested data field but not available (see SPO sentence in Clause A.13).
- 4) 9999 = requested data field but not available (see SPO sentence).
- 5) 0 = requested data field but not available (see SPO sentence).

Annex B (normative)

Legacy AIS Base Station sentences

B.1 Legacy sentences

B.1.1 BCE – Extended general Base Station configuration

This sentence and the BCF sentence are used to configure the Base Station parameters when it is initially installed, and later in order to make changes to the way it operates. This sentence is also used to monitor the UTC synchronisation source being used by the Base Station.

\$--BCE,c--c,a,a,x.x,x*hh<CR><LF>

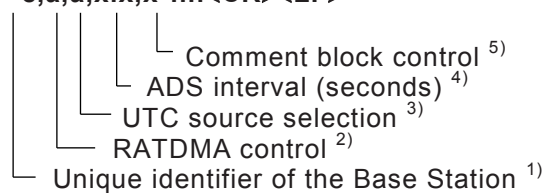

- 1) The unique identifier is used for system level identification of a station with a maximum of 15 alphanumeric characters. (See the SID sentence formatter). This data field should match the Base Station's unique identifier. The Base Station should ignore this sentence when this data field does not match the Base Station's unique identifier.
- 2) Controls the Base Station's ability to use RATDMA access to the VDL:
 0 = off (Base Station cannot use RATDMA access to VDL)
 1 = on (Base Station may use RATDMA access to VDL)
- 3) Controls the UTC synchronisation source used by the Base Station:
 E = external UTC source
 I = internal UTC source
 X = external UTC source with fallback to internal UTC source
 Y = internal UTC source with fallback to external UTC source, if available
- 4) The recommended interval is 60 s. This data field sets the interval between the output of "AIS device status" sentences (see ADS sentence.). If the value of this data field is zero or negative, the ADS sentences should not be provided. When the data field is zero or negative, the ADS will still be provided when there is a change in the status.
- 5) Comment blocks.
 0 – off (not required)
 1 – on (required)

B.1.2 BCF – General Base Station configuration

This sentence and the BCE sentence are used to configure the static Base Station parameters when it is initially installed, and later in order to make changes to the way it operates. Dynamic parameters (e.g. UTC and position of a moving Base Station) are input in a different way. This sentence supports system administration of the AIS Base Station operation.

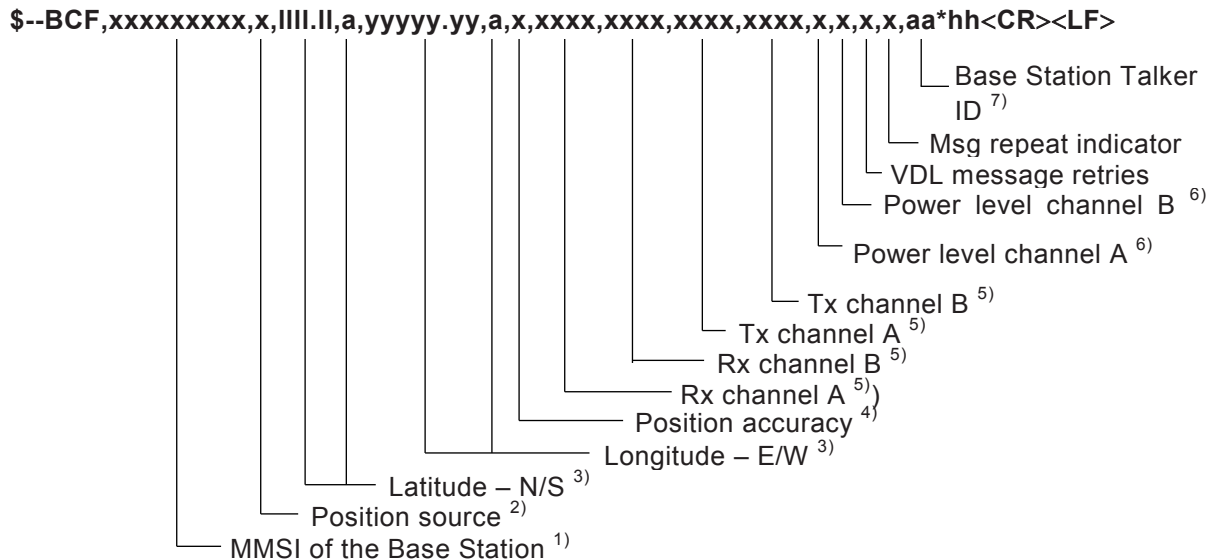

- 1) This data field is the MMSI of the Base Station. In early Base Stations, this data field sets the MMSI of the Base Station. For Base Stations built to comply with IEC 62320-1, this data field should not be used. The attached “comment block” parameter-code “d:” should be used to test if this sentence is intended for this Base Station. The Base Station should ignore this sentence if the parameter-code “d:” value in the attached comment block does not match the internal unique identifier (also, see the SID sentence).
- 2) Identifies the source of the position:
 - 0 = surveyed position (should always be used for Fixed AIS Base Station)
 - 1 = internal EPFS in use
 - 2 = external EPFS in use
 - 3 = internal EPFS in use with automatic fall back to surveyed position
 - 4 = internal EPFS in use with automatic fall back to external EPFS upon failure of internal EPFS
 - 5 = external EPFS in use with automatic fall back to surveyed position
 - 6 = external EPFS in use with automatic fall back to internal position source upon failure of external position source

Position sources 1, 2, 4 or 6 use automatic fall back to invalid position (181° Longitude and 91° Latitude)

When external EPFS is used (position sources 2, 4, 5 and 6), type of electronic position fixing device is provided by talker ID of the EPFS to be used in Message 4.
- 3) Surveyed position of the Base Station. [When a surveyed position is entered using the BCF sentence, the ‘Type of electronic position fixing device’ parameter broadcast by the Base Station in the VDL Message 4 should be ‘7’ (surveyed). When a surveyed position is provided as an automatic fall back (reference BCF Note 2; 3 – internal EPFS in use with automatic fall back to surveyed position), the ‘Type of electronic position fixing device’ parameter broadcast by the Base Station in the VDL Message 4 should be ‘7’ (surveyed).]
- 4) 0 = low >10 m
1 = high <10 m; differential mode of DGNSS
- 5) VHF channel number, see ITU-R M.1084, Annex 4.
- 6) 0 = high power (Nominal 12,5 W)
1 = low power (Nominal 2 W)
2 to 9 reserved for future use
- 7) The default Base Station talker identifier should be set to the primary design of the equipment. Equipment designed to IEC 62320-1 should have a default of AB.

AB = AIS Base Station

AL = limited Base Station

AS = simplex repeater station

AD = duplex repeater station

AR = receiving stations

B.1.3 CAB – Control AIS Base Station

This sentence is used to turn on or off the transmission of Channels A and B on an AIS Base Station and also to command a restart of the Base Station. This sentence supports system administration of the AIS Base Station operation.

\$--CAB,x,x,x,x*hh<CR><LF>

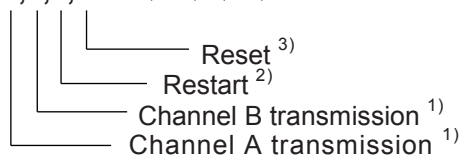

- 1) The field commands the Base Station to turn on or off transmissions on the selected channel (fields 1 or 2). There are two valid values for the field:
 - 0 = off
 - 1 = on
- 2) This field commands the Base Station to restart operations to last known configuration. The value of "1" indicates a restart. If a restart is not being indicated, this field is null.
- 3) This field commands the Base Station to reset all configuration information to undefined, with exception of receive only on AIS1 and AIS2. The value of "1" indicates a reset. If a reset is not being indicated, this field is null.

B.1.4 TSP – Transmit slot prohibit

This sentence is used to prohibit an AIS station from transmitting in the specified slots. The AIS station receiving this sentence should not use the next occurrence of the indicated slots. This sentence is designed to be used to protect interrogation responses from interference from Base Station transmissions.

\$--TSP,c--c,xx,a,HHMMSS.SS,x.x,x.x,x.x,x.x,x.x,x.x,x.x*hh<CR><LF>

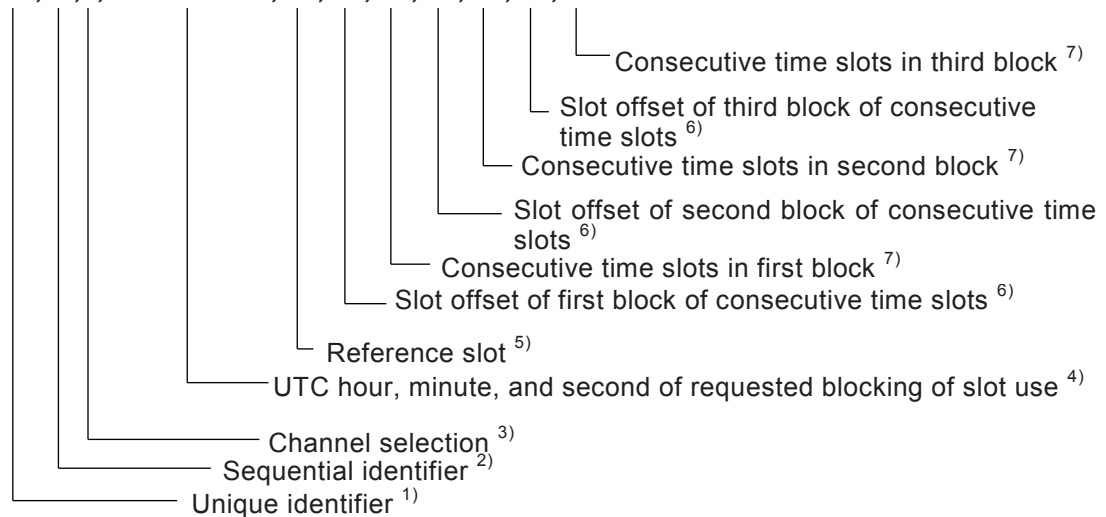

- 1) The unique identifier is used for system level identification of a station with a maximum of 15 alphanumeric characters. (See the SID sentence formatter). This data field should match the Base Station's unique identifier. The Base Station should ignore this sentence when this data field does not match the Base Station's unique identifier.
- 2) The sequential identifier provides an identification number from 0 to 99 that is sequentially assigned and is incremented for each new TSP sentence. The count resets to 0 after 99 is used. This sequential identifier is used to identify the Base Station's response of a slot prohibit status report (TSR).
- 3) A = Channel A
B = Channel B
- 4) This is for record keeping. It contains the hour, minute, and second of this request.
- 5) This is the slot from which the following slot offsets are referenced. This is frequently the slot assigned to a Message 15 interrogation.
- 6) Slot offset of the first slot in the block of slots to be blocked from use by the Base Station.
0 indicates no prohibited slots
- 7) Total number of consecutive slots to be blocked from use by the Base Station. The first slot of the block is also part of the count. Therefore, the minimum value is 1.
0 = no prohibited slots
1-5 = number of prohibited slots

B.2 Comment block

The comment block permits the addition of non-IEC 61162-1 information into a character stream containing IEC 61162-1 defined sentences. The comment block can be used to adapt sentences to other systems (such as an AIS network) without a change to a IEC 61162-1 sentence definition. A comment block can be used to associate or "link" various combinations of comment blocks, and sentences (see Clause A.3). The purpose of the comment block is the management of sentences, and to support transport of IEC 61162-1 sentences over any type of network – independent of the network's protocol. It is not intended to be the primary means for delivery of sensor data or control. IEC 61162-1 sentences should continue to be used for sensor data and control.

The "\ " character is designated as the "comment block delimiter." A comment block should begin with a "\ " character, and be closed with a "\ " character. The closing character is always preceded by the checksum (*hh) of the comment block content. When combined with a

standard sentence, the comment block should appear ahead of the sentence. The first comment block “\” appears after the <CR><LF> symbols. The comment block closing “\” appears before a symbol beginning a sentence, either a “\$” or “!”, or the <CR><LF> symbols. A comment block may also be used without a following IEC 61162-1 sentence; the closing “\” character is followed by the <CR><LF> symbols. This can be useful when line length is a concern.

The maximum number of characters in a comment block shall be 80 characters including the beginning and closing “\” comment block delimiters.

The contents of the comment block (valid characters between the two “\” characters) may contain any valid character (see IEC 61162-1:2010, Table 2) and some of the reserved characters (see IEC 61162-1:2010, Table 1). The comment block should not contain either the comment block delimiter, or the start of sentence delimiters, “\$” or “!”, or characters reserved for future use (“~” and).

The comment block content is considered in error if the listener calculated exclusive-or checksum of the comment block content does not equal the talker calculated checksum (*hh), or a start of sentence delimiter, “\$” or “!”, appears before the comment block is closed with a “*hh\”. The “\$” or “!” is always recognized as the beginning of an IEC 61162-1 sentence.

The remaining reserved characters (<CR>, <LF>, “,”, “*”, and “^”) in IEC 61162-1:2010, Table 1 should be used as defined there.

B.3 Comment block parameters for AIS

B.3.1 General

This clause describes the format, content, and rules to be used for inserting parameters into the comment blocks that are added to AIS-sentences. Following that, examples are given where the format, content, and rules are applied to sentences used with AIS Base Stations or AIS receivers.

B.3.2 Comment block parameter format

The general approach is to link each parameter value with a “parameter-code” that identifies the value. All parameters in a comment block use the following general form:

```
\Parameter-code:value,parameter-code:value,[etc.]*hh\
```

where the parameter-codes are defined in a parameter-code dictionary.

B.3.3 Comment block “hexadecimal checksum” (*hh)

In order to improve the integrity of the parameters in a comment block, the “XOR” hexadecimal checksum (*hh), that is calculated for every IEC 61162-1 sentence, should also be used for the content of each comment block (see examples below).

B.3.4 Line (either a comment block, or comment block and sentence)

A comment block can appear alone or combined with a sentence to form a “line”. When combined with a sentence, this is done without a <CR><LF> separating the two. The general form of a line is either:

```
\Parameter-code:value,...*hh\<CR><LF>
```

or

`\Parameter-code:value,...*hh\!AIVDM,...*hh<CR><LF>`

Inclusion of any character between the closing “\” character and the “start of sentence” delimiter breaks the association between a comment block and a sentence.

B.3.5 Group (associated lines)

The association of two or more lines forms a “group” (see B.3.7). Each line shall contain a comment block. Each line may or may not include a sentence. Multi-sentence messages may be in a group. The Data Fields supporting the multi-sentence should also be properly applied (See IEC 61162-1:2010, 7.3.9 (Multi-sentence messages)).

B.3.6 Parameter-code dictionary

The following are parameter-codes and their definitions:

- c: (*lower case “C”*) Time in seconds calculated from midnight January 1, 1970. This is a general time tag that can be attached to a line. The specific significance of this value depends on why the “source” attaches this value to the line.
- d: destination. Identification of intended listener device or process for the attached sentence. For a Base Station this is the SID sentence data field unique identifier.
- i: (*lower case “I”*) information. This is free form text using valid characters (see IEC 61162-1:2010, Table 2).
- s: (*lower case “S”*) source. Identification of the talker device or process for the attached sentence. For a Base Station this is the SID sentence data field unique identifier.
- x: (*lower case “X”*) counter. Always a positive integer beginning at “1”. This value is incremented by “1” for each occurrence of the parameter-code being used in a line generated by a talker [source].
- xGy: Coding used to link lines into a group. The required parameters are: sentence number, total number of sentences, and sequential identifier. Each combination of a comment block and an IEC 61162-1 sentence creates a “line”. A line containing only a comment block can be part of a group. The value of “x” (integer) indicates the line number within the group, and the “y” (integer) indicates the total number of lines in the group. The value with the parameter-code should be a unique string that is the same for each line in the group. This value is used to uniquely identify the lines of a group.

B.3.7 Line linking (sentence linking)

The combined use of the comment block and parameter-code dictionary can be used to efficiently link IEC 61162-1 sentences into a group. Once linked, these groups can be transported by a variety of communication mediums (serial port, USB, UDP, TCP/IP network connection, etc.). In general, these are data connections with multi-talker/multi-listener relationships; or a single-talker/multi-listener relationship where there can be timing issues among the talker’s internal processes (see the examples below).

Examples:

```
\1G2:1234,s:r3669961,c:1120959341*2D\!ABVDM,1,1,1,B,100000?0?wJm4:`GMUrf40g604:4,0*hh
```

```
\2G2:1234*79\!$ABVSI,r3669961,1,013536.96326433,1386,-98,*hh
```

```
\1G2:2346,s:r3669962,c:1120959342*2A\!ABVDM,1,1,1,B,15N1u<PP1cJnFj:GV4>:MOw:0<02,0*hh
```

```
\2G2:2346*7E\!$ABVSI,r3669962,1,013538.05654921,1427,-101,*hh
```

\1G2:1235,s:r3669961,c:1120959342*2F\!ABVDM,1,1,2,B,15N1u<PP1cJnFj:GV4>:MOw:0<02,0*hh

\2G2:1235*78\\$ABVSI,r3669961,2,013538.05656223,1427,-88,*hh

\1G2:1236,s:r3669961,c:1120959344*2A\!ABVDM,1,1,3,B,103OwmgP01Jn7WHGa4M6v?w<0D02,0*hh

\2G2:1236*7B\\$ABVSI,r3669961,3,013539.44331849,1479,-51,*hh

\1G2:2347,s:r3669962,c:1120959344*2D\!ABVDM,1,1,2,B,103OwmgP01Jn7WHGa4M6v?w<0D02,0*hh

\2G2:2347*7F\\$ABVSI,r3669962,2,013539.44333151,1479,-51,*hh

The previous example may also be presented as follows:

\1G3:1234,s:r3669961,c:1120959341*2C\

\2G3:1234*78\!ABVDM,1,1,1,B,100000?0?wJm4:`GMUrf40g604:4,0*hh

\3G3:1234*79\\$ABVSI,r3669961,1,013536.96326433,1386,-98,*hh

\1G3:2346,s:r3669962,c:1120959342*2B\

\2G3:2346*7F\!ABVDM,1,1,1,B,15N1u<PP1cJnFj:GV4>:MOw:0<02,0*hh

\3G3:2346*7E\\$ABVSI,r3669962,1,013538.05654921,1427,-101,*hh

\1G3:1235,s:r3669961,c:1120959342*2E\

\2G3:1235*79\!ABVDM,1,1,2,B,15N1u<PP1cJnFj:GV4>:MOw:0<02,0*hh

\3G3:1235*78\\$ABVSI,r3669961,2,013538.05656223,1427,-88,*hh

\1G3:1236,s:r3669961,c:1120959344*2B\

\2G3:1236*7A\!ABVDM,1,1,3,B,103OwmgP01Jn7WHGa4M6v?w<0D02,0*hh

\3G3:1236*7B\\$ABVSI,r3669961,3,013539.44331849,1479,-51,*hh

\1G3:2347,s:r3669962,c:1120959344*2C\

\2G3:2347*7E\!ABVDM,1,1,2,B,103OwmgP01Jn7WHGa4M6v?w<0D02,0*hh

\3G3:2347*7F\\$ABVSI,r3669962,2,013539.44333151,1479,-51,*hh

B.3.8 Comment block used with query sentences

B.3.8.1 General

A comment block may be linked to a query sentence (see 7.3.8 of IEC 61162-1:2010) to help ensure the desired device responds to a query. The way a Base Station processes and responds to a query sentence will depend on the structure of the query sentence:

- when a Base Station receives a query sentence without a comment block, the Base Station should respond using the rules described in 7.3.8 of IEC 61162-1:2010;
- when a Base Station receives a query sentence prefaced with a comment block, the Base Station should respond using the rules described in B.3.8.2 (below).

B.3.8.2 Reply to a \comment block\query sentence combination

The Base Station has a unique identifier. The unique identifier is installed in the Base Station using a SID-sentence. The “unique identifier” is used to identify the intended device for the query sentence, by including it with the destination (d:) parameter-code in the comment block. Consequently, a Base Station shall first check that the destination parameter-code ~~for a~~ matches with the “unique identifier” currently assigned to the Base Station.

The source of the query shall also be identified by providing a unique identifier with the source(s): parameter-code. The source’s unique identifier is used by the Base Station in the reply to the query.

B.3.8.3 Example of query using the \comment block\query format

In the following example, the query source is a computer with a talker identifier, PC, and a unique identifier, ControlPC1. The Base Station is assigned the talker identifier, AB, with a unique identifier, A003669955.

Example of a query that uses a comment block:

```
\s:ControlPC1,d:A003669955,c:1149654649*58\PCABQ,VER*2C
```

Response:

```
\s:A003669955,d:ControlPC1*2C\ABVER,AB,XYZ,A003669955,XYZ0001,Beta,0.1,0.1*2C
```

Annex C (normative)

IEC 61162-1 sentences modified for use with AIS Base Station

C.1 General

This annex contains CBR, MEB and NAK sentences which have been modified for use with the AIS Base Station. For the CBR and NAK sentences the structure of the sentences is unchanged and the changes concern the description of their use. For the MEB sentence the broadcast behaviour has been changed with consequential changes to that field.

NOTE Refer to IEC 61162-1 for possible later versions of these sentences.

C.2 CBR – Configure broadcast rates for AIS AtoN Station message command

This sentence configures slots and transmission intervals that will be used to broadcast AIS AtoN Station messages (see IEC 62320-2). The sentence supports scheduling of messages with real, virtual, and synthetic MMSIs (see AID sentence). The messages are assigned to the AIS AtoN Station for each channel.

Message 21 is defined by the content of the ACG and ACF sentences and is identified by the MMSI and the message ID 21. Message ID Index = 0 is reserved to define the on-position Message 21 transmission schedule. Message ID Index = 1 is reserved to define the off-position message 21 transmission schedule. The off-position schedule is optional (see ACG sentence, Off-position behaviour).

Other than Message 21, the combination of MMSI, Message ID, and Message ID Index are used to: (1) configure, (2) reference the AIS AtoN stations transmission slots, and (3) link to the MEB sentence.

Each message's transmission schedule is defined by the combination of Start UTC Hour, Start UTC Minute, Start Slot, and Slot Interval.

The AIS AtoN Station should apply this sentence to autonomously and continuously transmit VDL messages until revised by a subsequent CBR sentence. Subsequent CBR assignments override existing CBR assignments.

This sentence can be queried. The query response may contain one or more sentences and will continue until the transfer of all current schedule information is complete.

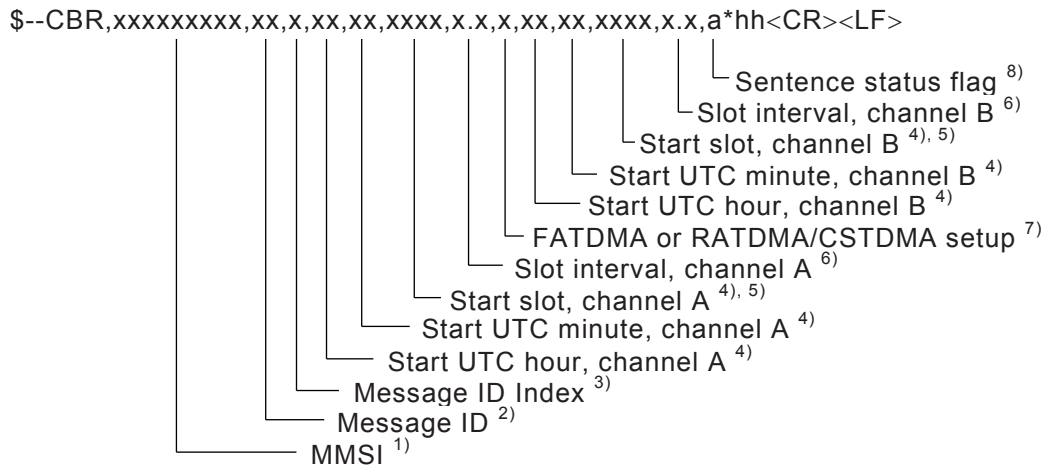

- 1) This is a MMSI previously defined for the AIS AtoN station (see AID sentence.).
- 2) Message ID is the number of the message being scheduled (see ITU-R M.1371). When Message ID is 0 this indicates that the slots being defined will be used for either chaining messages or MEB single transmissions (see IEC 62320-2).
- 3) Message ID Index is used to distinguish multiple occurrences of the same MMSI and Message ID combination. Valid range is 0 to 7.
- 4) Nominal start slot for each channel is determined by the combination of Start UTC hour, Start UTC minute, and Start slot.
- 5) Starting slot valid range is -1 to 2 249.
A value of -1 clears the schedule and discontinues the broadcasts for the indicated channel(s).
A null field indicates no change to the current start slot setting when sent to the AtoN Station. In response to a query this field cannot be null.
A value of -1 indicates that the message is not scheduled for broadcast on the indicated channel.
- 6) Message transmission slot interval, valid range is -1 to 3 240 000 slots ($24 \times 60 \times 2250 = 3\,240\,000$ is once per day). A null field indicates no change to the current slot interval setting when sent to the AtoN Station. In response to a query this field cannot be null, -1 indicates that the slot interval is not set.
- 7) Used to select whether the CBR is configuring a FATDMA schedule or RATDMA/CSTDMA schedule (0 indicates FATDMA, 1 indicates RATDMA, and 2 indicates CSTDMA). For RATDMA/CSTDMA mode, scheduled transmissions are between the slot interval and the slot interval plus 150 slots.
- 8) This field is used to indicate a sentence that is a status report of current settings or a configuration command changing settings. This field should not be null.

R = Sentence is a status report of current settings (use for a reply to a query).

C = Sentence is a configuration command to change settings. A sentence without "C" is not a command.

C.3 MEB – Message Input for broadcast command

This sentence is used to input a message for storage or immediate broadcast. The sentence associates messages with real, virtual, and synthetic MMSI's (see AID sentence).

The stored message is associated by the MMSI, Message ID, and Message ID Index. The combination of MMSI, Message ID, and Message ID Index are used to reference the stored message and link the message to a transmission schedule as defined by a CBR sentence. The stored message's broadcast begins when both the message content and schedule (see CBR sentence) have been entered.

For immediate message broadcast, the binary data will be broadcast using the slots reserved by the CBR sentence with both Message ID and Message ID Index = 0, or will be broadcast using the next available slot. The channel for the immediate message broadcast is specified by the “AIS channel for broadcast of the radio message” (parameter field 4).

This sentence can be queried. When queried, the query response may contain one or more sentences and will continue until the transfer of all stored information is complete.

!--MEB,x,x,x,x,xxxxxxxx,xx,x,x,xxxxxxxx,x,a,s--s,x*hh<CR><LF>

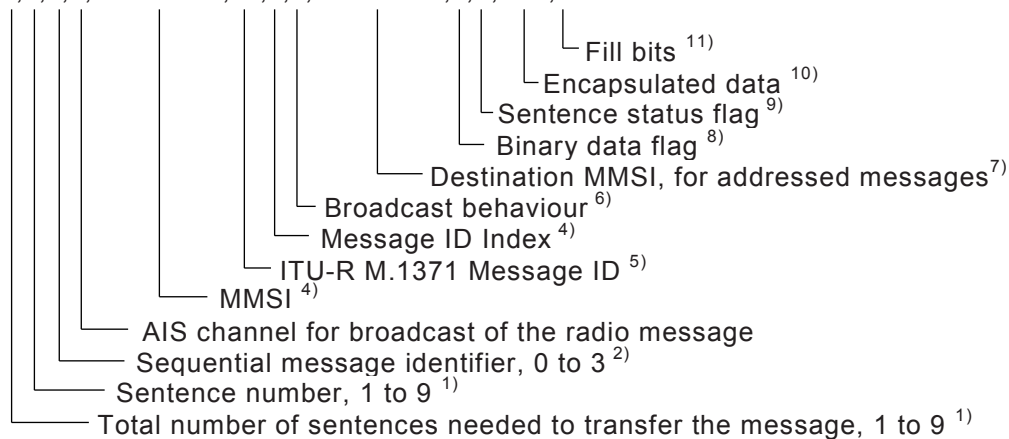

- 1) The total number of sentences required to transfer the binary message data to the AIS unit. The first field specifies the total number of sentences used for a message, minimum value 1. The second field identifies the order of this sentence in the message, minimum value 1. All sentences contain the same number of fields. Successive sentences may use null fields for fields that have not changed, such as fields 4, 5, 6, 7, 8, 9, and 10.
- 2) This sequential message identifier serves two purposes. It meets the requirements of IEC 61993-2 and it is the sequence number utilized by ITU-R M.1371 in Message types 6 and 12. The range of this field is restricted by ITU-R M.1371 to 0 – 3. The sequential message identifier value may be reused after the AIS unit provides the "ABK" acknowledgement for this number. (See ABK sentence).
- 3) The AIS channel that should be used for the broadcast:
 - 0 = no broadcast channel preference,
 - 1 = broadcast on AIS channel A,
 - 2 = broadcast on AIS channel B,
 - 3 = broadcast message on both AIS channels A and B,
 For an immediate message broadcast, this cannot be null. For a stored message it should be null.
- 4) For the message to be broadcast, this MMSI shall match a previously entered real, virtual, or synthetic MMSI (see AID and CBR sentences).
- 5) ITU-R M.1371 Messages supported by this sentence: 6, 8, 12, 14, 25, and 26. See IEC 62320-2 for the ITU-R M.1371 messages that are supported by an AIS AtoN Station.
- 6) 0 = For an AtoN device, the message is stored for autonomous continuous transmission as defined by a CBR sentence. The message is identified by the combination of MMSI, Message ID, and Message ID Index.
 - 1 = For an AtoN device, a single transmission (not stored in the “message table”) using the next available slot following slot selection priority:
 - use CBR definition, id 0, index 0 – if available).
 - use RATDMA (if supported by AtoN unit)
 - 2 – 9 = reserved for future use.

- 7) The “Destination MMSI, for Addressed Messages” should be a null field when the message is not destination specific, and is intended to be destination broadcast on the VHF Data Link.
- 8) The “Binary data flag” field has a range from 0 to 1 with the following meaning:
- 0 = unstructured binary data (no Application Identifier bits used)
- 1 = binary data coded as defined by using the 16-bit Application Identifier (see ITU-R M.1371, Messages 25 and 26)
- 9) This field is used to indicate a sentence that is a status report of current settings or a configuration command changing settings. This field should not be null.
- R = Sentence is a status report of current settings (use for a reply to a query).
- C = Sentence is a configuration command to change settings. A sentence without “C” is not a command.
- 10) This is the content of the “binary data” parameter for either ITU-R M.1371 Message 6, 8, 25, or 26, or the “Safety related Text” parameter for either Message 12 or 14. The actual number of “6-bit” symbols in a sentence shall be adjusted so that the total number of characters in a sentence does not exceed the “82-character” limit.
- 11) This field cannot be null.

C.4 NAK – Negative acknowledgement

In general, the NAK sentence is used when a reply to a query sentence cannot be provided, or when a command sentence is not accepted. The NAK sentence reply should be generated within 1 s.

A NAK can be used with or without a TAG Block. When the TAG Block feature is active, the NAK should use a TAG Block when appropriate. The NAK sentence is not used to report an “error” in the TAG Block portion of a “line”.

Use of NAK should be specified by the equipment standard.

This sentence cannot be queried.

\$--NAK,cc,ccc,c--c,x.x,c--c*hh<CR><LF>

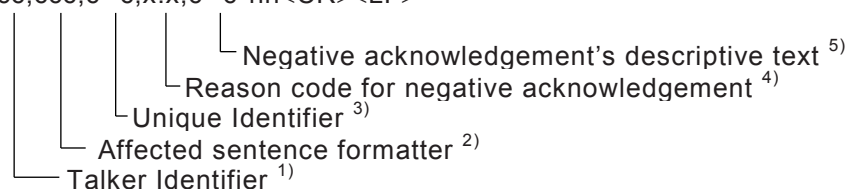

- 1) Talker identifier from the sentence formatter that caused the NAK generation. This field should not be null.
- 2) Affected sentence formatter is either:
- the “approved sentence formatter of data” being requested in a query that cannot be processed or accepted, or
 - the sentence formatter of the control or configuration sentence that cannot be processed or accepted.
- This field should not be null.
- 3) The Unique Identifier is used for system level identification of a device, 15 characters maximum. This is the Unique Identifier for the device producing the NAK sentence, when available. (See the SID sentence).
- 4) Reason codes:
- 0 = Query functionality not supported

1 = Sentence formatter not supported

2 = Sentence formatter supported, but not enabled

3 = Sentence formatter supported and enabled, but temporarily unavailable (e.g. data field problem, unit in initialize state, or in diagnostic state, etc.)

4 = Sentence formatter supported, but query for this sentence formatter is not supported.

5 = Access denied, for sentence formatter requested

6 = Sentence not accepted due to bad checksum

7 = Sentence not accepted due to listener processing issue

8 to 9: reserved for future use

10 = Cannot perform the requested operation.

11 = Cannot fulfill request or command because of a problem with a data field in the sentence.

12 to 48: reserved for future use

49 = other reason as described in data field 5.

Values greater than 50 may be defined by equipment standards.

This field should not be null.

- 5) The length of this field is constrained by the maximum sentence length. This field may be null.

Annex D (normative)

AIS Base Station TAG block sentences

D.1 General

This annex describes details of the TAG block sentences used with the AIS Base Station.

NOTE Refer to IEC 61162-1 for possible later versions of these sentences.

D.2 CPC – Configure parameter-code for UNIX time parameter (c)

This sentence configures and controls the addition of a UNIX time parameter to a talker TAG Block or its use as a listener. This is a command sentence.

Enabling this parameter-code talker: (1) causes a TAG Block containing this parameter-code to be linked to each talker sentence, (2) for different talker sentences linked using “sentence-grouping”, the grouped TAG Blocks (having the same “group-code” value) need only contain a single occurrence of this parameter-code.

The UNIX time parameter-code listener may be used to enable a time based process.

\$--CPC,c--c,a,a,a,x*hh<CR><LF>

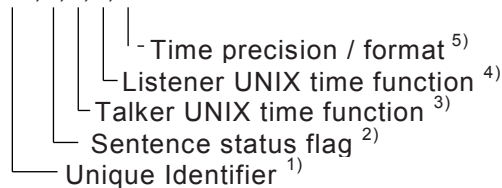

1) The Unique Identifier is used for system level identification of a device or process, 15 characters maximum. On input, and if the device or process has a Unique Identifier, this sentence should be accepted only if this data field matches the device's or process's Unique Identifier. On output, this data field is the device's or process's Unique Identifier.

2) This field is used to indicate a sentence that is a status report of current settings or a configuration command changing settings. This field should not be null.

R = Sentence is a status report of current settings (use for a reply to a query or TBR sentence).

C = Sentence is a configuration command to change settings. A sentence without “C” is not a command.

3) Configuration or status of Talker UNIX time function, parameter-code “c” for all output sentences (talker):

V = UNIX time function parameter disabled (off).

A = UNIX time function parameter enabled (on).

N = UNIX time function parameter enabled for a NAK sentence reply only. A TAG Block containing a UNIX time tag parameter will be linked to any NAK sentence reply.

U = unsupported.(status reply only).

4) Configuration or status of Listener UNIX time function, parameter-code “c” for all input sentences (listener):

V = UNIX time function parameter disabled (off).

A = UNIX time function parameter enabled (on).

U = unsupported (status reply only).

5) This controls the format of the UNIX time tag.

1 = integer seconds

2 = integer milliseconds (integer with units of milliseconds)

D.3 CPD – Configure parameter-code for Destination identification parameter (d)

This sentence controls the addition of a Destination identification parameter to a talker TAG Block or its use as a listener. This is a command sentence.

Enabling the “talker Destination identification” causes a TAG Block containing a destination-identification parameter to be linked to some talker sentences, when they are required. The Destination identification parameter is not required in all TAG Blocks.

Enabling the “listener Destination identification” requires the listener to apply the logic to each received line (TAG Block + sentence).

\$--CPD,c--c,a,a,a*hh<CR><LF>

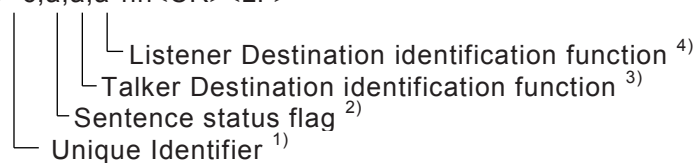

1) The Unique Identifier is used for system level identification of a device or process, 15 characters maximum. On input and if the device or process has a Unique Identifier, this sentence should be accepted only if this data field matches the device's or process's Unique Identifier. On output, this data field is the device's or process's Unique Identifier.

2) This field is used to indicate a sentence that is a status report of current settings or a configuration command changing settings. This field should not be null.

R = Sentence is a status report of current settings (use for a reply to a query or TBR sentence).

C = Sentence is a configuration command to change settings. A sentence without “C” is not a command.

3) Configuration or status of Talker Destination identification function, parameter-code “d” for output sentences that require a Destination identification parameter (talker):

V = Talker Destination identification function parameter disabled (off).

A = Talker Destination identification function parameter enabled (on). When a reply to an input sentence (e.g. Query, command, sentence requiring a NAK, etc.) is necessary, the response may be a sentence linked to a TAG Block containing a Destination identification.

U = unsupported (status reply only).

4) Configuration or status of Listener Destination identification function, parameter-code “d” for all input sentences (listener):

V = Listener Destination identification function parameter disabled (off).

A = Listener Destination identification function parameter enabled (on).

U = unsupported (status reply only).

D.4 CPG – Configure parameter-code for the sentence-grouping parameter (g)

This sentence controls the use of the sentence-grouping parameter information as a listener and talker within a TAG Block. This is a command sentence.

Enabling the “talker sentence-grouping” parameter permits a talker’s output sentences to be linked using the TAG Block sentence-grouping method, when required.

A sentence-grouping string is not required for a single sentence and is not required in all TAG Blocks. If only the sentence-grouping TAG Block feature is enabled, single sentence lines do not require a TAG Block (i.e., the notation “g:1-1-code” is not necessary).

Although TAG Block parameters may be in any order, when the sentence-grouping parameter is used, it should appear as the first parameter in the TAG Block.

Enabling the “listener sentence-grouping” parameter permits the listener to associate grouped sentences. If the listener sentence-grouping parameter is disabled, the sentence-grouping strings should be ignored, and the grouped sentences should not be handled as associated.

\$--CPG,c-c,a,a,x,x,x,x,x,x,x,x*hh<CR><LF>

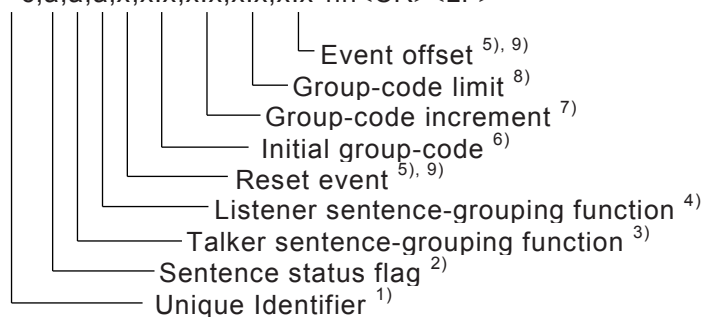

1) The Unique Identifier is used for system level identification of a device or process, 15 characters maximum. On input and if the device or process has a Unique Identifier, this sentence should be accepted only if this data field matches the device’s or process’s Unique Identifier. On output, this data field is the device’s or process’s Unique Identifier.

2) This field is used to indicate a sentence that is a status report of current settings or a configuration command changing settings. This field should not be null.

R = Sentence is a status report of current settings (use for a reply to a query or TBR sentence).

C = Sentence is a configuration command to change settings. A sentence without “C” is not a command.

3) Configuration or status of Talker sentence-grouping function, parameter-code “g” for all output sentences (talker):

V = sentence-grouping function parameter disabled (off).

A = sentence-grouping function parameter enabled (on).

U = unsupported (status reply only).

4) Configuration or status of Listener sentence-grouping function, parameter-code “g” for all input sentences (listener):

V = sentence-grouping function parameter disabled (off).

A = sentence-grouping function parameter enabled (on).

U = unsupported (status reply only).

5) The “Reset event” field defines the event that causes the “group-code” value of the TAG Block’s sentence-grouping Parameter-code to return (“reset”) to the “Initial group-code” value.

For a “Reset event” > 0, the event is a time that utilizes the equipment’s time reference. The event time needs to include the information from the “Event offset” field. Applying the “Event offset” value changes the time of the event by the sign of the “Event offset” (i.e. a negative offset moves the event to an earlier time, and a positive offset moves the event to a later time). Default value of 1.

If the “Reset event” is set to a value from 1 through 6, and the “Group-code limit” contains a value of 0 or greater, then arriving at either the “Group-code limit” value or the defined time event (see below) causes the “group-code” portion of the TAG Block’s sentence-grouping Parameter-code to return to the “Initial group-

code” value. That means, if either the “Group-code limit” is exceeded or the “Reset event” time is reached, the reset of the “group-code” is performed.

If the “Reset event” is a value from 1 to 6 (see below) and the “Group-code limit” contains a value of –1 (negative one), the “Group-code limit” is set to 0 for a negative “Group-code increment” (decrementing) and to 999 999 999 for a positive “Group-code increment”.

0 = use only the “Group-code limit”. The “Event offset” data field does not apply.

1 = daily (beginning next day)

2 = hourly (beginning of hour)

3 = every minute (beginning of minute)

4 = weekly (beginning of Sunday)

5 = monthly (beginning of month)

6 = yearly (beginning of year)

- 6) This is the initial group-code value (integer) after the group-code is reset. Default value of 1.
- 7) This is the Group-code increment value (integer). Default value of 1. A negative increment will decrement the group-code.
- 8) This data field may contain a floating numeric or integer value. The current group-code value (see g:) is compared to the group-code limit and is used to reset the group-code to the value of the Initial group-code. If the Group-code increment is positive, the group-code is reset to the Initial group-code when the group-code is greater than this value. If the Group-code increment is negative, the group-code is reset when the group-code is less than this value. This test is done before the group-code is output in the TAG Block. The group-code is incremented after it is output. The group-code limit may be a real number with a fractional part to ensure there is no ambiguity during the limit test. A value of –1 (negative one) for the “Group-code limit” sets the “Group-code limit” to 0 for a negative “Group-code increment”, and to 999 999 999 for a positive “Group-code increment”.
- 9) This is the offset in (+/-) seconds (see reference 5) above). Default value of 0. Null value indicates no change.

D.5 CPN – Configure parameter-code for the line-count parameter (n)

This sentence configures and controls the addition of a line-count parameter to a talker TAG Block or its use as a listener. This is a command sentence.

Enabling this parameter-code talker causes a TAG Block containing this (n) parameter-code to be linked to each talker line or sentence.

The line-count parameter-code listener may be used to enable a line-count reception process. The reception process details are not defined by this standard, but defined by the application or equipment performance standard specifying the use of this listener parameter code.

\$--CPN,c--c,a,a,x,x,x,x,x,x,x,x*hh<CR><LF>

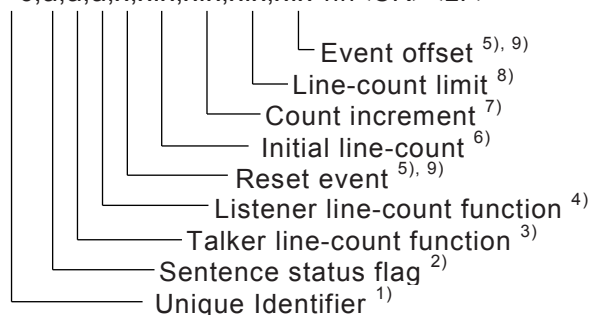

- 1) The Unique Identifier is used for system level identification of a device or process, 15 characters maximum. On input and if the device or process has a Unique Identifier, this sentence should be accepted only if this

data field matches the device's or process's Unique Identifier. On output, this data field is the device's or process's Unique Identifier.

- 2) This field is used to indicate a sentence that is a status report of current settings or a configuration command changing settings. This field should not be null.

R = Sentence is a status report of current settings (use for a reply to a query or TBR sentence).

C = Sentence is a configuration command to change settings. A sentence without "C" is not a command.

- 3) Configuration or status of Talker line-count function, parameter-code "n" for all output sentences (talker):

V = line-count function parameter disabled (off).

A = line-count function parameter enabled (on).

U = unsupported (status reply only).

- 4) Configuration or status of Listener line-count function, parameter-code "n" for all input sentences (listener):

V = line-count function parameter disabled (off).

A = line-count function parameter enabled (on).

U = unsupported (status reply only).

- 5) The "Reset event" field defines the event that causes the "line-count" value of the TAG Block's sentence-grouping Parameter-code to return ("reset") to the "Initial line-count" value.

For a "Reset event" > 0, the event is a time that utilizes the equipment's time reference. The event time needs to include the information from the "Event offset" field. Applying the "Event offset" value changes the time of the event by the sign of the "Event offset" (i.e. a negative offset moves the event to an earlier time, and a positive offset moves the event to a later time). Default value of 1.

If the "Reset event" is set to a value from 1 through 6, and the "Line-count limit" contains a value of 0 or greater, then arriving at either the "Line-count limit" value or the defined time event (see below) causes the "Line-count" portion of the TAG Block's line-count Parameter-code to return to the "Initial line-count" value. That means, if either the "Line-count limit" is exceeded or the "Reset event" time is reached, the reset of the "line-count" is performed.

If the "Reset event" is a value from 1 to 6 (see below) and the "Line-count limit" contains a value of -1 (negative one), the Line-count limit is set to 0 for a negative "Line-count increment" (decrementing) and to 999 999 999 for a positive "Line-count increment".

0 = using the line-count limit. The "Event offset" data field does not apply.

1 = daily (beginning next day)

2 = hourly (beginning of hour)

3 = every minute (beginning of minute)

4 = weekly (beginning of Sunday)

5 = monthly (beginning of month)

6 = yearly (beginning of year)

- 6) This is the initial line-number value (integer) after the line number is reset. Default value of 1.
- 7) This is the increment value (integer). Default value of 1. A negative increment will decrement the line number.
- 8) This data field may contain a floating numeric or integer value. The current line-count value (see n:) is compared to the line-count limit and is used to reset the line-count to the value of the Initial line-count. If the Count Increment is positive, the line-count is reset to the Initial line-count when the line-count is greater than this value. If the Count Increment is negative, the line-count is reset when the line-count is less than this value. This test is done before the line-count is output in the TAG Block. The line-count is incremented after it is output. The line-count limit may be a real number with a fractional part to ensure there is no ambiguity during the limit test. A value of -1 (negative one) for the "Line-count limit" sets the "Line-count limit" to 0 for a negative "Line-count increment" and to 999 999 999 for a positive "Line-count increment".
- 9) This is the offset in (+/-) seconds (see reference 5) above). Default value of 0. Null value indicates no change

D.6 CPS – Configure parameter-code for the Source identification parameter(s)

This sentence controls the addition of a Source identification parameter to a talker TAG Block or its use as a listener. This sentence is not used to enter a Source identification parameter. The SID sentence may be used to enter the Source identification parameter value. This is a command sentence.

Enabling the talker Source identification parameter-code causes a TAG Block containing a Source identification parameter to be linked to some talker sentences, as required. The talker Source identification parameter is not required in all TAG Blocks.

Enabling the listener Source identification parameter-code requires the listener to use the logic to be applied to each received line. The TBS sentence is used to enter the recognized Source identification values.

```
$--CPS,c--c,a,a,a*hh<CR><LF>
```

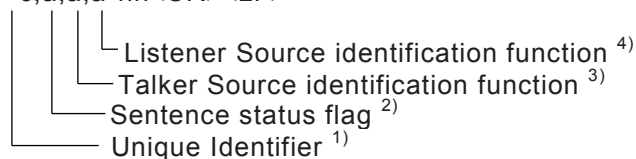

- 1) The Unique Identifier is used for system level identification of a device or process, 15 characters maximum. On input and if the device or process has a Unique Identifier, this sentence should be accepted only if this data field matches the device's or process's Unique Identifier. On output, this data field is the device's or process's Unique Identifier.
- 2) This field is used to indicate a sentence that is a status report of current settings or a configuration command changing settings. This field should not be null.
 - R = Sentence is a status report of current settings (use for a reply to a query or TBR sentence).
 - C = Sentence is a configuration command to change settings. A sentence without "C" is not a command.
- 3) Configuration or status of Talker Source identification function parameter-code "s" for all output sentences (talker):
 - V = Source identification function parameter disabled (off).
 - A = Source identification function parameter enabled (on).
 - N = Source identification parameter enabled for a NAK sentence reply only. A TAG Block containing a Source identification parameter will be linked to any NAK sentence reply.
 - U = unsupported (status reply only).
- 4) Configuration or status of Listener Source identification function, parameter-code "s" for all input sentences (listener):
 - V = Source identification function parameter disabled (off).
 - A = Source identification function parameter enabled (on).
 - U = unsupported (status reply only).

D.7 TBR – TAG block report request

The TBR sentence is used to request the identity and the data field content for all parameter-codes supported by a device.

Upon receiving a TBR sentence, the listener should reply with a separate "Configure Parameter-code" sentence (CPx) for each parameter-code that it supports. The reply should provide all the Data Field configuration values for each "Configure Parameter-code" sentence.

The TBR cannot be queried.

`$--TBR,c--c,a*hh<CR><LF>`

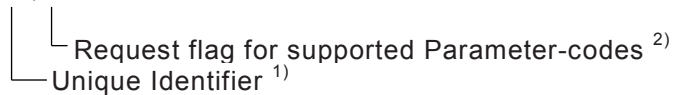

- 1) The Unique Identifier is used for system level identification of a device, 15 characters maximum. If the device has a Unique Identifier, this sentence should be ignored when this data field does not match the device's Unique Identifier.
- 2) A = Report all active (enabled) parameter-codes supported, their current status, and data field values.
S = Report all supported parameter-codes, their current status, and data field values.
I = Report all inactive (disabled) parameter-codes supported, their current status, and data field values.

D.8 TBS – TAG block listener Source identification configuration command

This sentence configures a listener's Source identification value(s). The value(s) are used by the "listener" device when the listener Source identification process function is enabled. This is a command sentence.

When the listener Source identification process function is enabled and a TAG Block containing a Source identification parameter code is received, the listener compares the received "s:" value with the value(s) configured by the TBS sentence. If there is no match, the line is not processed by the listener.

The TBS sentence does not set the device's "talker" Source identification value (see the SID and AID sentences).

This sentence provides a simple mechanism for properly routing sentences to and from listeners and talkers, but it does not provide a mechanism for maintaining the security of the routing.

This sentence can be queried. When queried, the query response may contain one or more sentences and will continue until the transfer of all current Source identification values is complete. The query response will not report the default Source identification, "DEFAULTSOURCE".

`$--TBS,c--c,a,x,c--c*hh<CR><LF>`

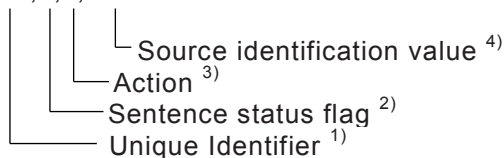

- 1) The Unique Identifier is used for system level identification of a device, 15 characters maximum. If the device has a Unique Identifier, this sentence should be ignored when this data field does not match the device's Unique Identifier.
- 2) This field is used to indicate a sentence that is a status report of current settings or a configuration command changing settings. This field should not be null.
R = Sentence is a status report of current settings (use for a reply to a query).
C = Sentence is a configuration command to change settings. A sentence without "C" is not a command.
- 3) The field specifies the specific configuration action. This field should not be null when field two is set to "C". This field should be null when field two is set to "R".

- 1 = Add the provided Source identification value (field 4) to the list of recognized sources.
- 2 = Remove the provided Source identification value (field 4) from the list of recognized sources.
- 3 = Remove all Source identification values from the list of recognized sources. The default value of "DEFAULTSOURCE" remains as the only recognized source.
- 4) Unique Identifier of recognized source, 15 characters maximum. When this sentence is a reply to a query, the reply should not include a sentence reporting the "DEFAULTSOURCE" Source identification.

Bibliography

ITU-T Recommendation O.153, *Basic parameters for the measurement of error performance at bit rates below the primary rate*

NMEA 0183, *National Maritime Electronics Association – Standard For Interfacing Marine Electronic Devices*

British Standards Institution (BSI)

BSI is the national body responsible for preparing British Standards and other standards-related publications, information and services.

BSI is incorporated by Royal Charter. British Standards and other standardization products are published by BSI Standards Limited.

About us

We bring together business, industry, government, consumers, innovators and others to shape their combined experience and expertise into standards-based solutions.

The knowledge embodied in our standards has been carefully assembled in a dependable format and refined through our open consultation process. Organizations of all sizes and across all sectors choose standards to help them achieve their goals.

Information on standards

We can provide you with the knowledge that your organization needs to succeed. Find out more about British Standards by visiting our website at bsigroup.com/standards or contacting our Customer Services team or Knowledge Centre.

Buying standards

You can buy and download PDF versions of BSI publications, including British and adopted European and international standards, through our website at bsigroup.com/shop, where hard copies can also be purchased.

If you need international and foreign standards from other Standards Development Organizations, hard copies can be ordered from our Customer Services team.

Subscriptions

Our range of subscription services are designed to make using standards easier for you. For further information on our subscription products go to bsigroup.com/subscriptions.

With **British Standards Online (BSOL)** you'll have instant access to over 55,000 British and adopted European and international standards from your desktop. It's available 24/7 and is refreshed daily so you'll always be up to date.

You can keep in touch with standards developments and receive substantial discounts on the purchase price of standards, both in single copy and subscription format, by becoming a **BSI Subscribing Member**.

PLUS is an updating service exclusive to BSI Subscribing Members. You will automatically receive the latest hard copy of your standards when they're revised or replaced.

To find out more about becoming a BSI Subscribing Member and the benefits of membership, please visit bsigroup.com/shop.

With a **Multi-User Network Licence (MUNL)** you are able to host standards publications on your intranet. Licences can cover as few or as many users as you wish. With updates supplied as soon as they're available, you can be sure your documentation is current. For further information, email bsmusales@bsigroup.com.

BSI Group Headquarters

389 Chiswick High Road London W4 4AL UK

Revisions

Our British Standards and other publications are updated by amendment or revision.

We continually improve the quality of our products and services to benefit your business. If you find an inaccuracy or ambiguity within a British Standard or other BSI publication please inform the Knowledge Centre.

Copyright

All the data, software and documentation set out in all British Standards and other BSI publications are the property of and copyrighted by BSI, or some person or entity that owns copyright in the information used (such as the international standardization bodies) and has formally licensed such information to BSI for commercial publication and use. Except as permitted under the Copyright, Designs and Patents Act 1988 no extract may be reproduced, stored in a retrieval system or transmitted in any form or by any means – electronic, photocopying, recording or otherwise – without prior written permission from BSI. Details and advice can be obtained from the Copyright & Licensing Department.

Useful Contacts:

Customer Services

Tel: +44 845 086 9001

Email (orders): orders@bsigroup.com

Email (enquiries): cservices@bsigroup.com

Subscriptions

Tel: +44 845 086 9001

Email: subscriptions@bsigroup.com

Knowledge Centre

Tel: +44 20 8996 7004

Email: knowledgecentre@bsigroup.com

Copyright & Licensing

Tel: +44 20 8996 7070

Email: copyright@bsigroup.com



...making excellence a habit.™