

BS EN 62305-3:2011



BSI Standards Publication

Protection against lightning

Part 3: Physical damage to structures and
life hazard

bsi.

...making excellence a habit.™

National foreword

This British Standard is the UK implementation of EN 62305-3:2011. It was derived from IEC 62305-3:2010. It supersedes BS EN 62305-3:2006, which will be withdrawn on 27 May 2012.

Parts 1, 3 and 4 of EN 62305 contain references to EN 62305-2:2011. This reference is incorrect since Part 2 is not due to be published until 2012 to allow for the finalization of the CENELEC common modifications.

Until EN 62305-2:2012 is published and adopted as BS EN 62305-2:2012, the existing BS EN 62305-2:2006 can continue to be used with the newly published BS EN 62305-1:2011, BS EN 62305-3:2011 and BS EN 62305-4:2011.

The CENELEC common modifications have been implemented at the appropriate places in the text and are indicated by tags (e.g. [C] [C]).

The UK participation in its preparation was entrusted to Technical Committee GEL/81, Protection against lightning.

A list of organizations represented on this committee can be obtained on request to its secretary.

This publication does not purport to include all the necessary provisions of a contract. Users are responsible for its correct application.

Compliance with a British Standard cannot confer immunity from legal obligations.

ISBN 978 0 580 61195 7

ICS 29.020; 91.120.40

This British Standard was published under the authority of the Standards Policy and Strategy Committee on 30 June 2011.

© BSI 2011

Amendments/corrigenda issued since publication

Date	Text affected
------	---------------

English version

**Protection against lightning -
Part 3: Physical damage to structures and life hazard
(IEC 62305-3:2010, modified)**

Protection contre la foudre -
Partie 3: Dommages physiques sur les
structures et risques humains
(CEI 62305-3:2010, modifiée)

Blitzschutz -
Teil 3: Schutz von baulichen Anlagen und
Personen
(IEC 62305-3:2010, modifiziert)

This European Standard was approved by CENELEC on 2011-01-02. CENELEC members are bound to comply with the CEN/CENELEC Internal Regulations which stipulate the conditions for giving this European Standard the status of a national standard without any alteration.

Up-to-date lists and bibliographical references concerning such national standards may be obtained on application to the Central Secretariat or to any CENELEC member.

This European Standard exists in three official versions (English, French, German). A version in any other language made by translation under the responsibility of a CENELEC member into its own language and notified to the Central Secretariat has the same status as the official versions.

CENELEC members are the national electrotechnical committees of Austria, Belgium, Bulgaria, Croatia, Cyprus, the Czech Republic, Denmark, Estonia, Finland, France, Germany, Greece, Hungary, Iceland, Ireland, Italy, Latvia, Lithuania, Luxembourg, Malta, the Netherlands, Norway, Poland, Portugal, Romania, Slovakia, Slovenia, Spain, Sweden, Switzerland and the United Kingdom.

CENELEC

European Committee for Electrotechnical Standardization
Comité Européen de Normalisation Electrotechnique
Europäisches Komitee für Elektrotechnische Normung

Management Centre: Avenue Marnix 17, B - 1000 Brussels

Foreword

The text of the International Standard IEC 62305-3:2010, prepared by IEC TC 81, Lightning protection, together with common modifications prepared by the Technical Committee CENELEC TC 81X, Lightning protection, was submitted to the formal vote and was approved by CENELEC as EN 62305-3 on 2011-01-02.

This European Standard supersedes EN 62305-3:2006 + corr. Nov.2006 + corr. Sep.2008 + A11:2009.

This EN 62305-3:2011 includes the following significant technical changes with respect to EN 62305-3:2006 + corr. Nov.2006 + corr. Sep.2008 + A11:2009:

- 1) Minimum thicknesses of metal sheets or metal pipes given in Table 3 for air-termination systems are assumed as not able to prevent hot-spot problems.
- 2) Steel with electro-deposited copper is introduced as material suitable for LPS.
- 3) Some cross-sectional areas of LPS conductors were slightly modified.
- 4) For bonding purposes, isolating spark gaps are used for metal installations and SPD for internal systems.
- 5) Two methods – simplified and detailed – are provided for evaluation of separation distance.
- 6) Protection measures against injuries of living beings due to electric shock are considered also inside the structure.
- 7) Improved information for LPS in the case of structures with a risk of explosion are given in Annex D (normative).

Attention is drawn to the possibility that some of the elements of this document may be the subject of patent rights. CEN and CENELEC shall not be held responsible for identifying any or all such patent rights.

The following dates were fixed:

- | | | |
|--|-------|------------|
| – latest date by which the EN has to be implemented at national level by publication of an identical national standard or by endorsement | (dop) | 2012-01-02 |
| – latest date by which the national standards conflicting with the EN have to be withdrawn | (dow) | 2014-01-02 |

Endorsement notice

The text of the International Standard IEC 62305-3:2010 was approved by CENELEC as a European Standard with agreed common modifications as given below.

In the official version, for Bibliography, the following note has to be added for the standard indicated:

[2] IEC 61400-24 NOTE Harmonized as EN 61400-24.

CONTENTS

FOREWORD.....	8
INTRODUCTION	11
1 Scope.....	12
2 Normative references.....	12
3 Terms and definitions.....	13
4 Lightning protection system (LPS).....	16
4.1 Class of LPS	16
4.2 Design of the LPS	17
4.3 Continuity of steelwork in reinforced concrete structures	17
5 External lightning protection system	18
5.1 General.....	18
5.1.1 Application of an external LPS.....	18
5.1.2 Choice of external LPS	18
5.1.3 Use of natural components.....	18
5.2 Air-termination systems	19
5.2.1 General.....	19
5.2.2 Positioning	19
5.2.3 Air-terminations against flashes to the side of tall structures.....	20
5.2.4 Construction	21
5.2.5 Natural components	21
5.3 Down-conductor systems	22
5.3.1 General.....	22
5.3.2 Positioning for an isolated LPS	23
5.3.3 Positioning for a non-isolated LPS	23
5.3.4 Construction.....	24
5.3.5 Natural components	24
5.3.6 Test joints	25
5.4 Earth-termination system	25
5.4.1 General.....	25
5.4.2 Earthing arrangement in general conditions	26
5.4.3 Installation of earth electrodes.....	27
5.4.4 Natural earth electrodes.....	28
5.5 Components	28
5.5.1 General.....	28
5.5.2 Fixing.....	29
5.5.3 Connections	29
5.6 Materials and dimensions.....	30
5.6.1 Materials	30
5.6.2 Dimensions	30
6 Internal lightning protection system	32
6.1 General.....	32
6.2 Lightning equipotential bonding	33
6.2.1 General.....	33
6.2.2 Lightning equipotential bonding for metal installations.....	33
6.2.3 Lightning equipotential bonding for external conductive parts.....	34
6.2.4 Lightning equipotential bonding for internal systems	35

6.2.5	Lightning equipotential bonding for lines connected to the structure to be protected	35
6.3	Electrical insulation of the external LPS	36
6.3.1	General	36
6.3.2	Simplified approach	37
6.3.3	Detailed approach	37
7	Maintenance and inspection of an LPS	38
7.1	General	38
7.2	Application of inspections	38
7.3	Order of inspections	38
7.4	Maintenance	38
8	Protection measures against injury to living beings due to touch and step voltages	38
8.1	Protection measures against touch voltages	38
8.2	Protection measures against step voltages	39
Annex A (normative)	Positioning the air-termination system	40
Annex B (normative)	Minimum cross-section of the entering cable screen in order to avoid dangerous sparking	46
Annex C (informative)	Evaluation of the separation distance s	47
Annex D (normative)	Additional information for LPS in the case of structures with a risk of explosion	53
Annex E (informative)	Guidelines for the design, construction, maintenance and inspection of lightning protection systems	60
Bibliography	157
Figure 1	– Protection angle corresponding to the class of LPS	20
Figure 2	– Loop in a down-conductor	24
Figure 3	– Minimum length l_1 of each earth electrode according to the class of LPS	26
Figure A.1	– Volume protected by a vertical air-termination rod	40
Figure A.2	– Volume protected by a vertical air-termination rod	41
Figure A.3	– Volume protected by a wire air-termination system	41
Figure A.4	– Volume protected by isolated wires combined in a mesh according to the protection angle method and rolling sphere method	42
Figure A.5	– Volume protected by non-isolated wires combined in a mesh according to the mesh method and the protection angle method	43
Figure A.6	– Design of an air-termination system according to the rolling sphere method	44
Figure C.1	– Values of coefficient k_C in the case of a wire air-termination system	47
Figure C.2	– Values of coefficient k_C in the case of multiple down-conductors system	48
Figure C.3	– Values of coefficient k_C in the case of a sloped roof with air-termination on the ridge	50
Figure C.4	– Examples of calculation of the separation distance in the case of multiple down-conductors with an interconnecting ring of the down-conductors at each level	51
Figure C.5	– Values of coefficient k_C in the case of a meshed air-termination system, with a multiple down-conductors system	52
Figure E.1	– LPS design flow diagram	62
Figure E.2	– LPS design for a cantilevered part of a structure	68
Figure E.3	– Measuring the overall electrical resistance	69

Figure E.4 – Equipotential bonding in a structure with a steel reinforcement	71
Figure E.5 – Typical methods of joining reinforcing rods in concrete (where permitted).....	72
Figure E.6 – Example of clamps used as joints between reinforcing rods and conductors.....	73
Figure E.7 – Examples for connection points to the reinforcement in a reinforced concrete wall.....	74
Figure E.8 – Use of metallic facade as natural down-conductor system and connection of facade supports.....	78
Figure E.9 – Connection of the continuous strip windows to a metal facade covering.....	79
Figure E.10 – Internal down-conductors in industrial structures	82
Figure E.11 – Installation of bonding conductors in reinforced concrete structures and flexible bonds between two reinforced concrete parts.....	84
Figure E.12 – Protection angle method air-termination design for different heights according to Table 2	88
Figure E.13 – Isolated external LPS using two isolated air-termination masts designed according to the protection angle air-termination design method.....	89
Figure E.14 – Isolated external LPS using two isolated air-termination masts, interconnected by horizontal catenary wire.....	90
Figure E.15 – Example of design of an air-termination of a non-isolated LPS by air- termination rods	91
Figure E.16 – Example of design of an air-termination of a non isolated LPS by a horizontal wire according to the protection angle air-termination design method.....	92
Figure E.17 – Protected volume of an air- termination rod on a sloped surface using the protection angle design method.....	93
Figure E.18 – Design of an LPS air-termination conductor network on a structure with complicated shape.....	94
Figure E.19 – Design of an LPS air-termination according to the protection angle method, mesh method and general arrangement of air-termination elements	95
Figure E.20 – Space protected by two parallel air-termination horizontal wires or two air-termination rods ($r > h_t$).....	96
Figure E.21 – Three examples of design of non-isolated LPS air-termination according to the mesh method air-termination design.....	99
Figure E.22 – Four examples of details of an LPS on a structure with sloped tiled roofs.....	101
Figure E.23 – Air-termination and visually concealed conductors for buildings less than 20 m high, with sloping roofs	102
Figure E.24 – Construction of an LPS using natural components on the roof of the structure.....	104
Figure E.25 – Positioning of the external LPS on a structure made of isolating material e.g. wood or bricks with a height up to 60 m with flat roof and with roof fixtures	105
Figure E.26 – Construction of air-termination network on a roof with conductive covering where puncturing of the covering is not acceptable	106
Figure E.27 – Construction of external LPS on a structure of steel-reinforced concrete using the reinforcement of the outer walls as natural components	107
Figure E.28 – Example of an air-termination stud used on car park roofs.....	108
Figure E.29 – Air-termination rod used for protection of a metallic roof fixture with electric power installations which are not bonded to the air-termination system.....	109
Figure E.30 – Method of achieving electrical continuity on metallic parapet capping	110
Figure E.31 – Metallic roof fixture protected against direct lightning interception, connected to air-termination system	113

Figure E.32 – Examples of lightning protection of a house with a TV antenna	116
Figure E.33 – Installation of lightning protection of metallic equipment on a roof against a direct lightning flash	117
Figure E.34 – Connection of natural air-termination rod to air-termination conductor	119
Figure E.35 – Construction of the bridging between the segments of the metallic facade plates	120
Figure E.36 – Installation of external LPS on a structure of insulating material with different roof levels	123
Figure E.37 – Five examples of geometry of LPS conductors	124
Figure E.38 – Construction of an LPS using only two down-conductors and foundation earth electrodes	125
Figure E.39 – Four examples of connection of earth-termination to the LPS of structures using natural down-conductors (girders) and detail of a test joint	129
Figure E.40 – Construction of foundation earth ring for structures of different foundation design	133
Figure E.41 – Two examples of vertical electrodes in type A earthing arrangement	135
Figure E.42 – Meshed earth-termination system of a plant	138
Figure E.43 – Example of an equipotential bonding arrangement	145
Figure E.44 – Example of bonding arrangement in a structure with multiple point entries of external conductive parts using a ring electrode for interconnection of bonding bars	146
Figure E.45 – Example of bonding in the case of multiple point entries of external conductive parts and an electric power or communication line using an internal ring conductor for interconnection of the bonding bars	147
Figure E.46 – Example of bonding arrangement in a structure with multiple point entries of external conductive parts entering the structure above ground level	148
Figure E.47 – Directions for calculations of the separation distance, s , for a worst case lightning interception point at a distance l from the reference point according to 6.3	150
Table 1 – Relation between lightning protection levels (LPL) and class of LPS (see EN 62305-1)	17
Table 2 – Maximum values of rolling sphere radius, mesh size and protection angle corresponding to the class of LPS	20
Table 3 – Minimum thickness of metal sheets or metal pipes in air-termination systems	22
Table 4 – Typical preferred values of the distance between down-conductors according to the class of LPS	23
Table 5 – LPS materials and conditions of use	29
Table 6 – Material, configuration and minimum cross-sectional area of air-termination conductors, air-termination rods, earth lead-in rods and down-conductors	31
Table 7 – Material, configuration and minimum dimensions of earth electrodes	32
Table 8 – Minimum dimensions of conductors connecting different bonding bars or connecting bonding bars to the earth-termination system	34
Table 9 – Minimum dimensions of conductors connecting internal metal installations to the bonding bar	34
Table 10 – Isolation of external LPS – Values of coefficient k_1	36
Table 11 – Isolation of external LPS – Values of coefficient k_m	36
Table 12 – Isolation of external LPS – Approximated values of coefficient k_c	37
Table B.1 – Cable length to be considered according to the condition of the screen	46
Table E.1 – Suggested fixing centres	100

Table E.2 – Maximum period between inspections of an LPS 152

INTERNATIONAL ELECTROTECHNICAL COMMISSION

PROTECTION AGAINST LIGHTNING –

Part 3: Physical damage to structures and life hazard

FOREWORD

- 1) The International Electrotechnical Commission (IEC) is a worldwide organization for standardization comprising all national electrotechnical committees (IEC National Committees). The object of IEC is to promote international co-operation on all questions concerning standardization in the electrical and electronic fields. To this end and in addition to other activities, IEC publishes International Standards, Technical Specifications, Technical Reports, Publicly Available Specifications (PAS) and Guides (hereafter referred to as "IEC Publication(s)"). Their preparation is entrusted to technical committees; any IEC National Committee interested in the subject dealt with may participate in this preparatory work. International, governmental and non-governmental organizations liaising with the IEC also participate in this preparation. IEC collaborates closely with the International Organization for Standardization (ISO) in accordance with conditions determined by agreement between the two organizations.
- 2) The formal decisions or agreements of IEC on technical matters express, as nearly as possible, an international consensus of opinion on the relevant subjects since each technical committee has representation from all interested IEC National Committees.
- 3) IEC Publications have the form of recommendations for international use and are accepted by IEC National Committees in that sense. While all reasonable efforts are made to ensure that the technical content of IEC Publications is accurate, IEC cannot be held responsible for the way in which they are used or for any misinterpretation by any end user.
- 4) In order to promote international uniformity, IEC National Committees undertake to apply IEC Publications transparently to the maximum extent possible in their national and regional publications. Any divergence between any IEC Publication and the corresponding national or regional publication shall be clearly indicated in the latter.
- 5) IEC itself does not provide any attestation of conformity. Independent certification bodies provide conformity assessment services and, in some areas, access to IEC marks of conformity. IEC is not responsible for any services carried out by independent certification bodies.
- 6) All users should ensure that they have the latest edition of this publication.
- 7) No liability shall attach to IEC or its directors, employees, servants or agents including individual experts and members of its technical committees and IEC National Committees for any personal injury, property damage or other damage of any nature whatsoever, whether direct or indirect, or for costs (including legal fees) and expenses arising out of the publication, use of, or reliance upon, this IEC Publication or any other IEC Publications.
- 8) Attention is drawn to the Normative references cited in this publication. Use of the referenced publications is indispensable for the correct application of this publication.
- 9) Attention is drawn to the possibility that some of the elements of this IEC Publication may be the subject of patent rights. IEC shall not be held responsible for identifying any or all such patent rights.

International Standard **EN 62305-3** has been prepared by IEC technical committee 81: Lightning protection.

This second edition cancels and replaces the first edition, published in 2006, and constitutes a technical revision.

This edition includes the following significant technical changes with respect to the previous edition:

- 1) Minimum thicknesses of metal sheets or metal pipes given in Table 3 for air-termination systems are assumed as not able to prevent hot-spot problems.
- 2) Steel with electro-deposited copper is introduced as material suitable for LPS.
- 3) Some cross-sectional areas of LPS conductors were slightly modified.
- 4) For bonding purposes, isolating spark gaps are used for metal installations and SPD for internal systems.

- 5) Two methods – simplified and detailed – are provided for evaluation of separation distance.
- 6) Protection measures against injuries of living beings due to electric shock are considered also inside the structure.
- 7) Improved information for LPS in the case of structures with a risk of explosion are given in Annex D (normative).

The text of this standard is based on the following documents:

FDIS	Report on voting
81/372/FDIS	81/382/RVD

Full information on the voting for the approval of this standard can be found in the report on voting indicated in the above table.

This publication has been drafted, as closely as possible, in accordance with the ISO/IEC Directives, Part 2.

A list of all the parts in the [EN 62305](#) series, under the general title *Protection against lightning*, can be found on the IEC website.

The committee has decided that the contents of this publication will remain unchanged until the stability date indicated on the IEC web site under "<http://webstore.iec.ch>" in the data related to the specific publication. At this date, the publication will be

- reconfirmed,
- withdrawn,
- replaced by a revised edition, or
- amended.

In the United States, based on the requirements of NFPA 780: Standard for the Installation of Lightning Protection Systems:2008 ^[1] 1 and practical experience in the use of horizontal earth electrodes, the minimum length of horizontal earth electrodes is not required to be twice that required for vertical electrodes.

In France and Portugal:

- natural components cannot substitute as lightning protection components but may be used to complete/enhance the LPS;
- aluminium solid round diameters should be increased from 8 mm to 10 mm;
- stranded conductors cannot be used as down-conductors;
- diameter of solid round conductors should be increased from 16 mm to 18 mm;
- hot dip galvanized steel solid tape thickness should be increased from 2 mm to 3,5 mm.

In Russia the use of piping carrying and tanks containing readily-combustible or explosive materials as air-termination natural components or down-conductor natural components are not allowed in any case.

In Japan the minimum values of the cross-section are reduced from:

- 16 mm² to 14 mm² for copper and 25 mm² to 22 mm² for aluminium, for bonding conductors connecting different bonding bars and conductors connecting the bars to the earth-termination system;
- 6 mm² to 5 mm² for copper, 10 mm² to 8 mm² for aluminium and 16 mm² to 14 mm² for steel, for bonding conductors connecting internal metal installations to the bonding bars.

A bilingual version of this publication may be issued at a later date.

IMPORTANT – The 'colour inside' logo on the cover page of this publication indicates that it contains colours which are considered to be useful for the correct understanding of its contents. Users should therefore print this document using a colour printer.

¹ References in square brackets refer to the bibliography.

INTRODUCTION

This part of [C] EN 62305 [C] deals with the protection, in and around a structure, against physical damage and injury to living beings due to touch and step voltages.

The main and most effective measure for protection of structures against physical damage is considered to be the lightning protection system (LPS). It usually consists of both external and internal lightning protection systems.

An external LPS is intended to

- a) intercept a lightning flash to the structure (with an air-termination system),
- b) conduct the lightning current safely towards earth (using a down-conductor system),
- c) disperse the lightning current into the earth (using an earth-termination system).

An internal LPS prevents dangerous sparking within the structure using either equipotential bonding or a separation distance (and hence electrical insulation) between the external LPS (as defined in 3.2) components and other electrically conducting elements internal to the structure.

Main protection measures against injury to living beings due to touch and step voltages are intended to:

- 1) reduce the dangerous current flowing through bodies by insulating exposed conductive parts, and/or by increasing the surface soil resistivity,
- 2) reduce the occurrence of dangerous touch and step voltages by physical restrictions and/or warning notices.

The type and location of an LPS should be carefully considered in the initial design of a new structure, thereby enabling maximum advantage to be taken of the electrically conductive parts of the structure. By doing so, design and construction of an integrated installation is made easier, the overall aesthetic aspects can be improved, and the effectiveness of the LPS can be increased at minimum cost and effort.

Access to the ground and the proper use of foundation steelwork for the purpose of forming an effective earth-termination may well be impossible once construction work on a site has commenced. Therefore, soil resistivity and the nature of the earth should be considered at the earliest possible stage of a project. This information is fundamental to the design of an earth-termination system and may influence the foundation design work for the structure.

Regular consultation between LPS designers and installers, architects and builders is essential in order to achieve the best result at minimum cost.

If lightning protection is to be added to an existing structure, every effort should be made to ensure that it conforms to the principles of this standard. The design of the type and location of an LPS should take into account the features of the existing structure.

PROTECTION AGAINST LIGHTNING –

Part 3: Physical damage to structures and life hazard

1 Scope

This part of EN 62305 provides the requirements for protection of a structure against physical damage by means of a lightning protection system (LPS), and for protection against injury to living beings due to touch and step voltages in the vicinity of an LPS (see EN 62305-1).

This standard is applicable to:

- a) design, installation, inspection and maintenance of an LPS for structures without limitation of their height,
- b) establishment of measures for protection against injury to living beings due to touch and step voltages.

NOTE 1 Specific requirements for an LPS in structures dangerous to their surroundings due to the risk of explosion are under consideration. Additional information is provided in Annex D for use in the interim.

NOTE 2 This part of EN 62305 is not intended to provide protection against failures of electrical and electronic systems due to overvoltages. Specific requirements for such cases are provided in EN 62305-4.

NOTE 3 Specific requirements for protection against lightning of wind turbines are reported in IEC 61400-24^[2].

2 Normative references

The following referenced documents are indispensable for the application of this document. For dated references, only the edition cited applies. For undated references, the latest edition of the referenced document (including any amendments) applies.

EN 50164-1	Lightning Protection Components (LPC) – Part 1: Requirements for connection components
EN 50164-2	Lightning Protection Components (LPC) – Part 2: Requirements for conductors and earth electrodes
EN 50164-3	Lightning Protection Components (LPC) – Part 3: Requirements for isolating spark gaps
EN 50164-4	Lightning Protection Components (LPC) – Part 4: Requirements for conductor fasteners
EN 50164-5	Lightning Protection Components (LPC) – Part 5: Requirements for earth electrode inspection housings and earth electrode seals
EN 50164-6	Lightning Protection Components (LPC) – Part 6: Requirements for lightning strike counters
EN 50164-7	Lightning Protection Components (LPC) – Part 7: Requirements for earthing enhancing compounds

NOTE The above mentioned standards EN 50164 series will ultimately be replaced by EN 62561 series. EN 50164 series will still be valid for 72 months from the issuing date of each part of the EN 50164 series.

EN 60079-10-1:2009	Explosive atmospheres – Part 10-1: Classification of areas – Explosive gas atmospheres (IEC 60079-10-1:2008)
EN 60079-10-2:2009	Explosive atmospheres – Part 10-2: Classification of areas – Combustible dust atmospheres (IEC 60079-10-2:2009)
EN 60079-14:2008	Explosive atmospheres – Part 14: Electrical installations design, selection and erection (IEC 60079-14:2007)
EN 61557-4	Electrical safety in low voltage distribution systems up to 1 000 V a.c. and 1 500 V d.c. – Equipment for testing, measuring or monitoring of protective measures – Part 4: Resistance of earth connection and equipotential bonding (IEC 61557-4)

☐ EN 61643-11	Low-voltage surge protective devices – Part 1: Surge protective devices connected to low-voltage power distribution systems – Requirements and tests (IEC 61643-1)
EN 61643-21	Low voltage surge protective devices – Part 21: Surge protective devices connected to telecommunications and signalling networks – Performance requirements and testing methods (IEC 61643-21)
EN 62305-1:2011	Protection against lightning – Part 1: General principles (IEC 62305-1:2010, modified)
EN 62305-2:2011	Protection against lightning – Part 2: Risk management (IEC 62305-2:2010, modified)
EN 62305-4:2011	Protection against lightning – Part 4: Electrical and electronic systems within structures (IEC 62305-4:2010, modified)
EN 62561 series ¹⁾	Lightning Protection System Components (LPSC) (IEC 62561 series)
EN 62561-1 ²⁾	Lightning Protection System Components (LPSC) – Part 1: Requirements for connection components (IEC 62561)
EN 62561-3 ²⁾	Lightning Protection System Components (LPSC) – Part 3: Requirements for isolating spark gaps (IEC 62561-3)
ISO 3864-1	Graphical symbols – Safety colours and safety signs – Part 1: Design principles for safety signs in workplaces and public areas ☐

3 Terms and definitions

For the purposes of this document, the following terms and definitions, some of which have already been cited in Part 1 but are repeated here for ease of reference, as well as those given in other parts of ☐ EN 62305 ☐, apply.

3.1

lightning protection system

LPS

complete system used to reduce physical damage due to lightning flashes to a structure

NOTE It consists of both external and internal lightning protection systems.

3.2

external lightning protection system

part of the LPS consisting of an air-termination system, a down-conductor system and an earth-termination system

3.3

external LPS isolated from the structure to be protected

LPS with an air-termination system and down-conductor system positioned in such a way that the path of the lightning current has no contact with the structure to be protected

NOTE In an isolated LPS, dangerous sparks between the LPS and the structure are avoided.

3.4

external LPS not isolated from the structure to be protected

LPS with an air-termination system and down-conductor system positioned in such a way that the path of the lightning current can be in contact with the structure to be protected

3.5

internal lightning protection system

part of the LPS consisting of lightning equipotential bonding and/or electrical insulation of external LPS

3.6

air-termination system

part of an external LPS using metallic elements such as rods, mesh conductors or catenary wires intended to intercept lightning flashes

¹⁾ In preparation.

²⁾ At draft stage.

3.7

down-conductor system

part of an external LPS intended to conduct lightning current between the air-termination system and the earth-termination system

3.8

ring conductor

conductor forming a loop around the structure and interconnecting the down-conductors for distribution of lightning current among them

3.9

earth-termination system

part of an external LPS which is intended to conduct and disperse lightning current into the earth

3.10

earth electrode

part or a group of parts of the earth-termination system which provides direct electrical contact with the earth and disperses lightning current to the earth

3.11

ring earth electrode

earth electrode forming a closed loop around the structure below or on the surface of the earth

3.12

foundation earth electrode

conductive part buried in the soil under a building foundation or, preferably, embedded in concrete of a building foundation, generally in form of a closed loop

[IEC 60050-826:2004, 826-13-08] ^[3]

3.13

conventional earth impedance

ratio of the peak values of the earth-termination voltage and the earth-termination current which, in general, do not occur simultaneously

3.14

earth-termination voltage

potential difference between the earth-termination system and the remote earth

3.15

natural component of LPS

conductive component installed not specifically for lightning protection which can be used in addition to the LPS or in some cases could provide the function of one or more parts of the LPS

NOTE Examples of the use of this term include:

- natural air-termination;
- natural down-conductor;
- natural earth electrode.

3.16

connecting component

part of an LPS which is used for the connection of conductors to each other or to metallic installations **[C]** as defined in the EN 50164 series **[C]**

NOTE This also includes bridging component and expansion piece.

3.17

fixing component

part of an LPS which is used to fix the elements of the LPS to the structure to be protected
[C] as defined in the EN 50164 series [C]

3.18

metal installations

extended metal items in the structure to be protected which may form a path for lightning current, such as pipework, staircases, elevator guide rails, ventilation, heating and air-conditioning ducts, interconnected reinforcing steel, structural metal parts

3.19

external conductive parts

extended metal items entering or leaving the structure to be protected such as pipework, metallic cable elements, metal ducts, etc. which may carry a part of the lightning current

3.20

electrical system

system incorporating low-voltage power supply components

3.21

electronic system

system incorporating sensitive electronic components such as telecommunication equipment, computer, control and instrumentation systems, radio systems, power electronic installations

3.22

internal systems

electrical and electronic systems within a structure

3.23

lightning equipotential bonding

EB

bonding to the LPS of separated conductive parts, by direct connections or via surge protective devices, to reduce potential differences caused by lightning current

3.24

bonding bar

metal bar on which metal installations, external conductive parts, electric power and telecommunication lines and other cables can be bonded to an LPS

3.25

bonding conductor

conductor connecting separated conductive parts to LPS

3.26

interconnected reinforcing steel

steelwork within a concrete structure which is considered electrically continuous

3.27

dangerous sparking

electrical discharge due to lightning which causes physical damage in the structure to be protected

3.28

separation distance

distance between two conductive parts at which no dangerous sparking can occur

3.29

surge protective device

SPD

device intended to limit transient overvoltages and divert surge currents; contains at least one non linear component

3.30

test joint

joint designed to facilitate electrical testing and measurement of LPS components

3.31

class of LPS

number denoting the classification of an LPS according to the lightning protection level for which it is designed

3.32

lightning protection designer

specialist competent and skilled in the design of the LPS

3.33

lightning protection installer

person competent and skilled in the installation of the LPS

3.34

structures with risk of explosion

structures containing solid explosives materials or hazardous zones as determined in accordance with IEC 60079-10-1 and IEC 60079-10-2

3.35

isolating spark gap

ISG

component with discharge distance for isolating electrically conductive installation sections

NOTE In the event of a lightning strike, the installation sections are temporarily connected conductively as the result of response to the discharge.

3.36

isolating interfaces

devices which are capable of reducing conducted surges on lines entering the LPZ

NOTE 1 These include isolation transformers with earthed screen between windings, metal-free fibre optic cables and opto-isolators.

NOTE 2 Insulation withstand characteristics of these devices are suitable for this application intrinsically or via SPD.

4 Lightning protection system (LPS)

4.1 Class of LPS

The characteristics of an LPS are determined by the characteristics of the structure to be protected and by the considered lightning protection level.

Four classes of LPS (I to IV), as shown in Table 1, are defined in this standard corresponding to lightning protection levels defined in [EN 62305-1](#).

Table 1 – Relation between lightning protection levels (LPL) and class of LPS (see [C] EN 62305-1 [C])

LPL	Class of LPS
I	I
II	II
III	III
IV	IV

Each class of LPS is characterized by the following:

- a) Data dependent upon the class of LPS:
 - lightning parameters (see Tables 3 and 4 in [C] EN 62305-1:2010 [C]);
 - rolling sphere radius, mesh size and protection angle (see 5.2.2);
 - typical preferred distances between down-conductors (see 5.3.3);
 - separation distance against dangerous sparking (see 6.3);
 - minimum length of earth electrodes (see 5.4.2).
- b) Factors not dependent upon the class of LPS:
 - lightning equipotential bonding (see 6.2);
 - minimum thickness of metal sheets or metal pipes in air-termination systems (see 5.2.5);
 - LPS materials and conditions of use (see 5.5.1);
 - material, configuration and minimum dimensions for air-terminations, down-conductors and earth-terminations (see 5.6);
 - minimum dimensions of connecting conductors (see 6.2.2).

Performance of each class of LPS is given in Annex B of [C] EN 62305-2:2010 [C].

The class of required LPS shall be selected on the basis of a risk assessment (see [C] EN 62305-2 [C]).

4.2 Design of the LPS

A technically and economically optimized design of an LPS is possible, especially if the steps in the design and construction of the LPS are coordinated with the steps in the design and construction of the structure to be protected. In particular, the design of the structure itself should utilize the metal parts of the structure as parts of the LPS.

The design of the class and location of the LPS for existing structures shall take into account the constraints of the existing situation.

The design documentation of an LPS shall contain all the information necessary to ensure correct and complete installation. For detailed information, see Annex E.

The LPS should be designed and installed by well-trained and expert LPS designers and installers (see E.4.2)

4.3 Continuity of steelwork in reinforced concrete structures

Steelwork within reinforced concrete structures is considered to be electrically continuous provided that the major part of interconnections of vertical and horizontal bars are welded or otherwise securely connected. Connections of vertical bars shall be welded, clamped or overlapped a minimum of 20 times their diameters and bound or otherwise securely connected (see Figure E.5). For new structures, the connections between reinforcement

elements shall be specified by the designer or installer, in cooperation with the builder and the civil engineer.

For structures utilizing steel-reinforced concrete (including pre-cast, pre-stressed reinforced units), the electrical continuity of the reinforcing bars shall be determined by electrical testing between the uppermost part and ground level. The overall electrical resistance should not be greater than $0,2 \Omega$, measured using test equipment suitable for this purpose. If this value is not achieved, or it is not practical to conduct such testing, the reinforcing steel shall not be used as a natural down-conductor as discussed in 5.3.5. In this case it is recommended that an external down-conductor system be installed. In the case of structures of pre-cast reinforced concrete, the electrical continuity of the reinforcing steel shall be established between individual adjacent pre-cast concrete units.

NOTE 1 For further information on the continuity of steelwork in reinforced concrete structures, see Annex E.

NOTE 2 When the continuity of steelwork in reinforced concrete is intended to be established by clamping, specifically designed clamps complying with and tested according to EN 50164-1, should be used.

NOTE 3 Clamps to establish the continuity of steelwork in reinforced concrete should comply with the future EN 62561-1.

5 External lightning protection system

5.1 General

5.1.1 Application of an external LPS

The external LPS is intended to intercept direct lightning flashes to the structure, including flashes to the side of the structure, and conduct the lightning current from the point of strike to ground. The external LPS is also intended to disperse this current into the earth without causing thermal or mechanical damage, or dangerous sparking which may trigger fire or explosions.

5.1.2 Choice of external LPS

In most cases, the external LPS may be attached to the structure to be protected.

An isolated external LPS should be considered when the thermal and explosive effects at the point of strike, or on the conductors carrying the lightning current, may cause damage to the structure or to the contents (see Annex E). Typical examples include structures with combustible covering, structures with combustible walls and areas at risk of explosion and fire.

NOTE The use of an isolated LPS may be convenient where it is predicted that changes in the structure, its contents or its use will require modifications to the LPS.

An isolated external LPS may also be considered when the susceptibility of the contents warrants the reduction of the radiated electromagnetic field associated with the lightning current pulse in the down-conductor.

5.1.3 Use of natural components

Natural components made of conductive materials, which will always remain in/on the structure and will not be modified (e.g. interconnected steel-reinforcement, metal framework of the structure, etc.) may be used as parts of an LPS.

Other natural components can only be considered as being additional to an LPS.

NOTE For further information, see Annex E.

5.2 Air-termination systems

5.2.1 General

The probability of structure penetration by a lightning current is considerably decreased by the presence of a properly designed air-termination system.

Air-termination systems can be composed of any combination of the following elements:

- a) rods (including free-standing masts);
- b) catenary wires;
- c) meshed conductors.

To conform to this standard, all types of air-termination systems shall be positioned in accordance with 5.2.2, 5.2.3 and Annex A. All types of air terminals shall comply in full with this standard.

For all types of air terminals only the real physical dimensions of the metal air-termination systems shall be used for the determination of the volume protected.

The individual air-termination rods should be connected together at roof level to ensure current division.

Radioactive air terminals are not allowed.

5.2.2 Positioning

Air-termination components installed on a structure shall be located at corners, exposed points and edges (especially on the upper level of any facades) in accordance with one or more of the following methods.

Acceptable methods to be used in determining the position of the air-termination system include:

- the protection angle method;
- the rolling sphere method;
- the mesh method.

The rolling sphere method is suitable in all cases.

The protection angle method is suitable for simple-shaped buildings but it is subject to limits of air-termination height indicated in Table 2.

The mesh method is a suitable form of protection where plane surfaces are to be protected.

The values for the protection angle, rolling sphere radius and mesh size for each class of LPS are given in Table 2 and Figure 1. Detailed information on the positioning of the air-termination system is given in Annex A.

Table 2 – Maximum values of rolling sphere radius, mesh size and protection angle corresponding to the class of LPS

Class of LPS	Protection method		Protection angle α°
	Rolling sphere radius r m	Mesh size w_m m	
I	20	5 × 5	See Figure 1 below
II	30	10 × 10	
III	45	15 × 15	
IV	60	20 × 20	

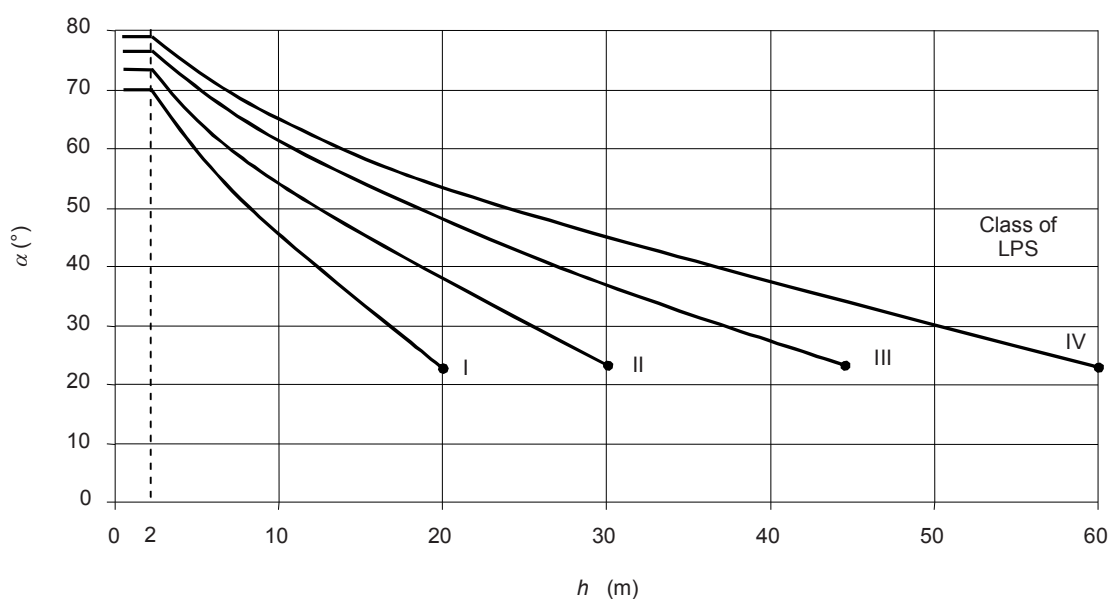

IEC 2646/10

NOTE 1 Not applicable beyond the values marked with •. Only rolling sphere and mesh methods apply in these cases.

NOTE 2 h is the height of air-termination above the reference plane of the area to be protected.

NOTE 3 The angle will not change for values of h below 2 m.

Figure 1 – Protection angle corresponding to the class of LPS

5.2.3 Air-terminations against flashes to the side of tall structures

5.2.3.1 Structures less than 60 m tall

Research indicates that the probability of low amplitude strikes to the vertical side of a structure of less than 60 m in height are low enough that they need not be considered. Roofs and horizontal protrusions shall be protected in accordance with the class of LPS determined by the risk calculations of [C] EN 62305-2. [C]

5.2.3.2 Structures 60 m in height or more

On structures taller than 60 m, flashes to the side may occur, especially to points, corners and edges of surfaces.

NOTE 1 In general the risk due to these flashes is low because only a few per cent of all flashes to tall structures will be to the side and moreover their parameters are significantly lower than those of flashes to the top of structures. However, electrical and electronic equipment on walls outside structures may be destroyed even by lightning flashes with low current peak values.

An air-termination system shall be installed to protect the upper part of tall structures (i.e. typically the topmost 20 % of the height of the structure as far as this part exceeds 60 m in height) and the equipment installed on it (see Annex A).

The rules for positioning the air-termination systems on these upper parts of a structure shall meet at least the requirements for LPL IV with emphasis on the location of air-termination devices on corners, edges, and significant protrusions (such as balconies, viewing platforms, etc.).

The air-termination requirement for the side of a tall structure may be satisfied by the presence of external metallic materials such as metal cladding or metallic curtain walls provided they meet the minimum size requirements of Table 3. The air-termination requirement may also include the use of external down-conductors located on the vertical edges of the structure when not provided by natural external metallic conductors.

The installed or naturally occurring air-terminations meeting these requirements may utilize installed down-conductors or be suitably interconnected with natural down-conductors such as the steel frame of the structure or the metal of electrically-continuous reinforced concrete meeting the requirements of 5.3.5.

NOTE 2 Use of suitable earth-termination and natural down-conductors is encouraged.

5.2.4 Construction

Air-terminations of an LPS not isolated from the structure to be protected may be installed as follows:

- if the roof is made of non-combustible material the air-termination conductors may be positioned on the surface of the roof;
- if the roof is made of readily-combustible material, due care needs to be taken with regard to the distance between the air-termination conductors and the material. For thatched roofs, where no steel bars are used for mounting of the reed, a distance of at least 0,15 m is adequate. For other combustible materials a distance not lower than 0,10 m is considered adequate;
- easily-combustible parts of the structure to be protected shall not remain in direct contact with the components of an external LPS and shall not remain directly under any metallic roofing membrane that might be punctured by a lightning flash (see 5.2.5).

Account shall also be taken of less combustible membranes such as wooden sheets.

NOTE If it is likely that water may accumulate on a flat roof, air-terminations should be installed above the highest probable water level.

5.2.5 Natural components

The following parts of a structure should be considered and may be used as natural air-termination components and part of an LPS in accordance with 5.1.3.

- a) Metal sheets covering the structure to be protected provided that
 - the electrical continuity between the various parts is made durable (e.g. by means of brazing, welding, crimping, seaming, screwing or bolting),
 - the thickness of the metal sheet is not less than the value t' given in Table 3 if it is not important to prevent puncture of the sheeting or to consider ignition of any readily-combustible materials underneath,

- the thickness of the metal sheet is not less than the value t given in Table 3 if it is necessary to take precautions against puncture or to consider hot spot problems,

NOTE 1 Where hot spot or ignition problems may arise, it should be verified that the temperature rise of the inner surface at the point of strike does not constitute a danger. Hot spot or ignition problems can be disregarded when the metal sheets lies inside an LPZ0_B or higher.

- they are not clad with insulating material.

Table 3 – Minimum thickness of metal sheets or metal pipes in air-termination systems

Class of LPS	Material	Thickness ^a t mm	Thickness ^b t' mm
I to IV	Lead	–	2,0
	Steel (stainless, galvanized)	4	0,5
	Titanium	4	0,5
	Copper	5	0,5
	Aluminium	7	0,65
	Zinc	–	0,7
^a t prevents puncture. ^b t' only for metal sheets if it is not important to prevent puncture, hot spot or ignition problems.			

- b) Metal components of roof construction (trusses, interconnected reinforcing steel, etc.), underneath non-metallic roofing, provided that damage to this non-metallic roofing is acceptable.
- c) Metal parts such as ornamentation, railings, pipes, coverings of parapets, etc., with cross-sections not less than that specified for standard air-termination components.
- d) Metal pipes and tanks on the roof, provided that they are constructed of material with thicknesses and cross-sections in accordance with Table 6.
- e) Metal pipes and tanks carrying readily-combustible or explosive mixtures, provided that they are constructed of material with thickness not less than the appropriate value of t given in Table 3 and that the temperature rise of the inner surface at the point of strike does not constitute a danger (for detailed information, see Annex D).

If the conditions for thickness are not fulfilled, the pipes and tanks shall be included into the structure to be protected.

Piping carrying readily-combustible or explosive mixtures shall not be considered as an air-termination natural component if the gasket in the flange couplings is not metallic or if the flange-sides are not otherwise properly bonded.

NOTE 2 A thin coating of protective paint or about 1 mm asphalt or 0,5 mm PVC is not regarded as an insulator. Detailed information is given in E.5.3.4.1 and in E.5.3.4.2.

5.3 Down-conductor systems

5.3.1 General

In order to reduce the probability of damage due to lightning current flowing in the LPS, the down-conductors shall be arranged in such a way that from the point of strike to earth:

- a) several parallel current paths exist;
- b) the length of the current paths is kept to a minimum;

- c) equipotential bonding to conducting parts of the structure is performed according to the requirements of 6.2.

NOTE 1 Lateral connection of down-conductors is considered to be good practice.

The geometry of the down-conductors and of the ring conductors affects the separation distance (see 6.3).

NOTE 2 The installation of as many down-conductors as possible, at equal spacing around the perimeter interconnected by ring conductors, reduces the probability of dangerous sparking and facilitates the protection of internal installations (see **EN 62305-4**). This condition is fulfilled in metal framework structures and in reinforced concrete structures in which the interconnected steel is electrically continuous.

Typical values of the preferred distance between down-conductors are given in Table 4.

More information on partitioning of the lightning current amongst down-conductors is given in Annex C.

5.3.2 Positioning for an isolated LPS

The positioning shall be as follows:

- a) If the air-termination consists of rods on separate masts (or one mast) not made of metal or interconnected reinforcing steel, at least one down-conductor is needed for each mast. No additional down-conductors are required for masts made of metal or interconnected reinforcing steel.

NOTE In several countries, the use of reinforced concrete as a part of the LPS is not allowed.

- b) If the air-termination consists of catenary wires (or one wire), at least one down-conductor is needed at each supporting structure.
- c) If the air-termination forms a network of conductors, one down-conductor is needed at least at each supporting wire end.

5.3.3 Positioning for a non-isolated LPS

For each non-isolated LPS the number of down-conductors shall be not less than two and should be distributed around the perimeter of the structure to be protected, subject to architectural and practical constraints.

An equal spacing of the down-conductors is preferred around the perimeter. Typical preferred values of the distance between down-conductors are given in Table 4.

NOTE The value of the distance between down-conductors is correlated with the separation distance given in 6.3.

Table 4 – Typical preferred values of the distance between down-conductors according to the class of LPS

Class of LPS	Typical distances m
I	10
II	10
III	15
IV	20

A down-conductor should be installed at each exposed corner of the structure, where this is possible.

5.3.4 Construction

The down-conductors shall be installed so that, as far as practicable, they form a direct continuation of the air-termination conductors.

Down-conductors shall be installed straight and vertical such that they provide the shortest and most direct path to earth. The formation of loops shall be avoided, but where this is not possible, the distance s , measured across the gap between two points on the conductor and the length, l , of the conductor between those points (see Figure 2) shall conform to 6.3.

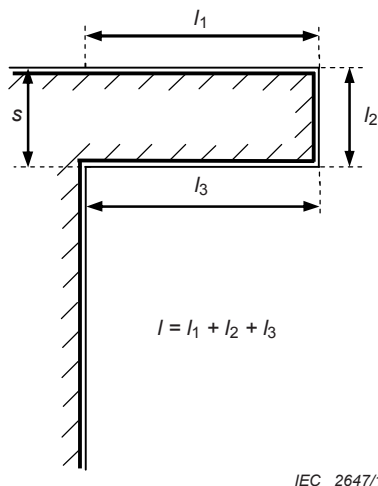

Figure 2 – Loop in a down-conductor

Down-conductors, even if covered in insulating material, shall not be installed in gutters or water spouts.

NOTE The effects of moisture in the gutters lead to intensive corrosion of the down-conductor.

It is recommended that the down-conductors be positioned such that a separation distance in accordance with 6.3 is provided between them and any doors and windows.

Down-conductors of an LPS not isolated from the structure to be protected may be installed as follows:

- if the wall is made of non-combustible material, the down-conductors may be positioned on the surface or in the wall;
- if the wall is made of readily-combustible material the down-conductors may be positioned on the surface of the wall, provided that their temperature rise due to the passage of lightning current is not dangerous for the material of the wall;
- if the wall is made of readily-combustible material and the temperature rise of down-conductors is dangerous, the down-conductors shall be placed in such a way that the distance between them and the wall is always greater than 0,1 m. Mounting brackets may be in contact with the wall.

When the distance from down-conductor to a combustible material cannot be assured, the cross-section of the steel or thermal equivalent conductor shall be not less than 100 mm².

5.3.5 Natural components

The following parts of the structure may be used as natural down-conductors:

- a) the metal installations provided that

- the electrical continuity between the various parts is made durable in accordance with 5.5.3,
- their dimensions are at least equal to that specified in Table 6 for standard down-conductors.

Piping carrying readily-combustible or explosive mixtures shall not be considered as a down-conductor natural component if the gasket in the flange couplings is not metallic or if the flange-sides are not otherwise properly bonded.

NOTE 1 Metal installations may be clad with insulating material.

- b) the metal of the electrically-continuous reinforced concrete framework of the structure;

NOTE 2 With prefabricated reinforced concrete, it is important to establish interconnection points between the reinforcing elements. It is also important that reinforced concrete contains a conductive connection between the interconnection points. The individual parts should be connected on-site during assembly (see Annex E).

NOTE 3 In the case of pre-stressed concrete, attention should be paid to the risk of causing unacceptable mechanical consequences, due either to lightning current or as a result of the connection to the lightning protection system.

- c) the interconnected steel framework of the structure;

NOTE 4 Ring conductors are not necessary if the metal framework of steel structures or the interconnected reinforcing steel of the structure is used as down-conductors.

- d) the facade elements, profile rails and metallic sub-constructions of facades, provided that
- their dimensions conform to the requirements for down-conductors (see 5.6.2) and that for metal sheets or metal pipes thicknesses shall be not less than 0,5 mm,
 - their electrical continuity in a vertical direction conforms to the requirements of 5.5.3.

NOTE 5 For more information, see Annex E.

5.3.6 Test joints

At the connection of the earth-termination, a test joint should be fitted on each down-conductor, except in the case of natural down-conductors combined with foundation earth electrodes.

For measuring purposes, the joint shall be capable of being opened with the aid of a tool. In normal use it shall remain closed.

5.4 Earth-termination system

5.4.1 General

When dealing with the dispersion of the lightning current (high frequency behaviour) into the ground, whilst minimizing any potentially dangerous overvoltages, the shape and dimensions of the earth-termination system are the important criteria. In general, a low earthing resistance (if possible lower than 10 Ω when measured at low frequency) is recommended.

From the viewpoint of lightning protection, a single integrated structure earth-termination system is preferable and is suitable for all purposes (i.e. lightning protection, power systems and telecommunication systems).

Earth-termination systems shall be bonded in accordance with the requirements of 6.2.

NOTE 1 The conditions of separation and bonding of other earth-termination systems are usually determined by the appropriate national authorities.

NOTE 2 Serious corrosion problems can occur when earthing systems made of different materials are connected to each other.

5.4.2 Earthing arrangement in general conditions

For earth-termination systems, two basic types of earth electrode arrangements apply.

5.4.2.1 Type A arrangement

This type of arrangement comprises horizontal or vertical earth electrodes installed outside the structure to be protected connected to each down-conductor or foundation earth electrodes not forming a closed loop.

In type A arrangements, the total number of earth electrodes shall be not less than two.

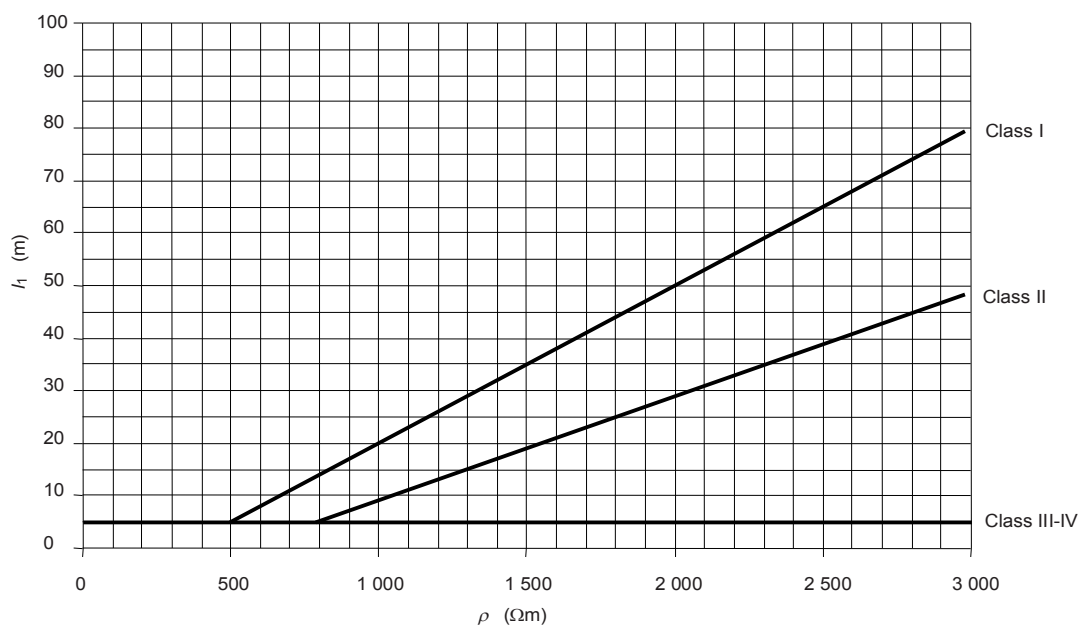

IEC 2648/10

NOTE Classes III and IV are independent of soil resistivity.

Figure 3 – Minimum length l_1 of each earth electrode according to the class of LPS

The minimum length of each earth electrode at the base of each down-conductor is

- l_1 for horizontal electrodes, or
- $0,5 l_1$ for vertical (or inclined) electrodes,

where l_1 is the minimum length of horizontal electrodes shown in the relevant part of Figure 3.

For combined (vertical or horizontal) electrodes, the total length shall be considered.

The minimum lengths stated in Figure 3 may be disregarded provided that an earthing resistance of the earth-termination system less than 10Ω (measured at a frequency different from the power frequency and its multiple in order to avoid interference) is achieved.

NOTE 1 When the above-mentioned requirements cannot be met, a type B earth arrangement shall be used.

NOTE 2 Reduction of earthing resistance by the extension of earth electrodes is practically convenient up to 60 m. In soil with resistivity higher than $3\,000 \Omega\text{m}$, the use of type B earth electrodes or earthing enhancing compounds is recommended.

NOTE 3 For further information, refer to Annex E.

5.4.2.2 Type B arrangement

This type of arrangement comprises either a ring conductor external to the structure to be protected, in contact with the soil for at least 80 % of its total length, or a foundation earth electrode forming a closed loop. Such earth electrodes may also be meshed.

NOTE Although 20 % may not be in contact with the soil, the ring conductor must always be completely connected throughout its total length.

For the ring earth electrode (or foundation earth electrode), the mean radius r_e of the area enclosed by the ring earth electrode (or foundation earth electrode) shall be not less than the value l_1 :

$$r_e \geq l_1 \quad (1)$$

where l_1 is represented in Figure 3 according to LPS class I, II, III and IV.

When the required value of l_1 is larger than the convenient value of r_e , additional horizontal or vertical (or inclined) electrodes shall be added with individual lengths l_r (horizontal) and l_v (vertical) given by the following equations:

$$l_r = l_1 - r_e \quad (2)$$

and

$$l_v = (l_1 - r_e) / 2 \quad (3)$$

It is recommended that the number of electrodes shall be not less than the number of the down-conductors, with a minimum of two.

The additional electrodes should be connected to the ring earth electrode at points where the down-conductors are connected and, for as many as possible, equidistantly.

5.4.3 Installation of earth electrodes

The ring earth electrode (type B arrangement) should preferably be buried at a depth of at least 0,5 m and at a distance of about 1 m away from the external walls.

The earth electrodes (type A arrangement) shall be installed at a depth of upper end at least 0,5 m and distributed as uniformly as possible to minimize electrical coupling effects in the earth.

NOTE 1 If the type A earth electrode is positioned within an inspection housing which, in turn, is located in high resistance paving or adjoining concrete, then the 0,5 m requirement can be disregarded.

Earth electrodes shall be installed in such a way as to allow inspection during construction.

The embedded depth and the type of earth electrodes shall be such as to minimize the effects of corrosion, soil drying and freezing and thereby stabilize the conventional earth resistance. It is recommended that the upper part of a vertical earth electrode equal to the depth of freezing soil should not be regarded as being effective under frost conditions.

NOTE 2 Hence, for every vertical electrode, 0,5 m should be added to the value of the length l_1 , calculated in 5.4.2.1 and 5.4.2.2.

For bare solid rock, a type B earthing arrangement is recommended.

For structures with extensive electronic systems or with high risk of fire, type B earthing arrangement is preferable.

5.4.4 Natural earth electrodes

Interconnected reinforcing steel in concrete foundations in accordance with 5.6, or other suitable underground metal structures, should preferably be used as an earth electrode. When the metallic reinforcement in concrete is used as an earth electrode, special care shall be exercised at the interconnections to prevent mechanical splitting of the concrete.

NOTE 1 In the case of pre-stressed concrete, consideration should be given to the consequences of the passage of lightning discharge currents which may produce unacceptable mechanical stresses.

NOTE 2 If a foundation earth electrode is used, a long-term increase in earthing resistance is possible.

NOTE 3 More extensive information on this topic is reported in Annex E.

5.5 Components

5.5.1 General

Components of LPS shall withstand the electromagnetic effects of lightning current and predictable accidental stresses without being damaged. This can be achieved by choosing components that have successfully been tested in accordance with the future **EN 50164** series.

EN 50164 All components shall comply with the EN 50164 series.

Components of an LPS shall be manufactured from the materials listed in Table 5 or from other materials with equivalent mechanical, electrical and chemical (corrosion) performance characteristics.

NOTE Components made of material other than metal may be used for fixing.

Table 5 – LPS materials and conditions of use^a

Material	Use			Corrosion		
	In open air	In earth	In concrete	Resistance	Increased by	May be destroyed by galvanic coupling with
Copper	Solid Stranded	Solid Stranded As coating	Solid Stranded As coating	Good in many environments	Sulphur compounds Organic materials	–
Hot galvanized steel ^{c, d, e}	Solid Stranded ^b	Solid	Solid Stranded ^b	Acceptable in air, in concrete and in benign soil	High chlorides content	Copper
Steel with electro-deposited copper	Solid	Solid	Solid	Good in many environments	Sulphur compounds	
Stainless steel	Solid Stranded	Solid Stranded	Solid Stranded	Good in many environments	High chlorides content	–
Aluminium	Solid Stranded	Unsuitable	Unsuitable	Good in atmospheres containing low concentrations of sulphur and chloride	Alkaline solutions	Copper
Lead ^f	Solid As coating	Solid As coating	Unsuitable	Good in atmosphere with high concentration of sulphates	Acid soils	Copper Stainless steel

^a This table gives general guidance only. In special circumstances more careful corrosion immunity considerations are required (see Annex E).

^b Stranded conductors are more vulnerable to corrosion than solid conductors. Stranded conductors are also vulnerable where they enter or exit earth/concrete positions. This is the reason why stranded galvanized steel is not recommended in earth.

^c Galvanized steel may be corroded in clay soil or moist soil.

^d Galvanized steel in concrete should not extend into the soil due to possible corrosion of the steel just outside the concrete.

^e Galvanized steel in contact with reinforcement steel in concrete should not be used in coastal areas where there may be salt in the ground water

^f Use of lead in the earth is often banned or restricted due to environmental concerns.

5.5.2 Fixing

Air-terminations and down-conductors shall be firmly fixed so that the electrodynamic or accidental mechanical forces (for instance vibrations, slipping of slabs of snow, thermal expansion, etc.) will not cause conductors to break or loosen (see Annex D of [EN 62305-1:2010](#)).

NOTE Recommended distances between fixings are reported in Table E.1.

5.5.3 Connections

The number of connections along the conductors shall be kept to a minimum. Connections shall be made secure by such means as brazing, welding, clamping, crimping, seaming, screwing or bolting.

To achieve this, connections of steelwork within reinforced concrete structures shall conform to 4.3 and shall comply with the requirements and tests according to [C] EN 50164-1. [C]

5.6 Materials and dimensions

5.6.1 Materials

Material and its dimensions shall be chosen bearing in mind the possibility of corrosion either of the structure to be protected or of the LPS.

5.6.2 Dimensions

- [C] Materials, configurations and minimum cross-sectional areas of air-termination conductors, air-termination rods, down-conductors and earth lead-in rods are given in Table 6 and shall comply with the requirements and tests according to the EN 50164 series. [C]
- [C] Materials, Configurations and minimum dimensions of earth electrodes are given in Table 7 and shall comply with the requirements and tests according to the future EN 50164 series. [C]

Table 6 – Material, configuration and minimum cross-sectional area of air-termination conductors, air-termination rods, earth lead-in rods and down-conductors^a

Material	Configuration	Cross-sectional area mm ²
Copper, Tin plated copper	Solid tape	50
	Solid round ^b	50
	Stranded ^b	50
	Solid round ^c	176
Aluminium	Solid tape	70
	Solid round	50
	Stranded	50
Aluminium alloy	Solid tape	50
	Solid round	50
	Stranded	50
	Solid round ^c	176
Copper coated aluminium alloy	Solid round	50
Hot dipped galvanized steel	Solid tape	50
	Solid round	50
	Stranded	50
	Solid round ^c	176
Copper coated steel	Solid round	50
	Solid tape	50
Stainless steel	Solid tape ^d	50
	Solid round ^d	50
	Stranded	70
	Solid round ^c	176

^a Mechanical and electrical characteristics as well as corrosion resistance properties shall meet the requirements of the future **EN 50164** series.

^b 50 mm² (8 mm diameter) may be reduced to 25 mm² in certain applications where mechanical strength is not an essential requirement. Consideration should in this case, be given to reducing the spacing between the fasteners.

^c Applicable for air-termination rods and earth lead-in rods. For air-termination rods where mechanical stress such as wind loading is not critical, a 9,5 mm diameter, 1 m long rod may be used.

^d If thermal and mechanical considerations are important then these values should be increased to 75 mm².

Table 7 – Material, configuration and minimum dimensions of earth electrodes^{a, e}

Material	Configuration	Dimensions		
		Earth rod diameter mm	Earth conductor mm ²	Earth plate mm
Copper Tin plated copper	Stranded		50	
	Solid round	15	50	
	Solid tape		50	
	Pipe	20		
	Solid plate			500 × 500
	Lattice plate ^c			600 × 600
Hot dipped galvanized steel	Solid round	14	78	
	Pipe	25		
	Solid tape		90	
	Solid plate			500 × 500
	Lattice plate ^c			600 × 600
	Profile	^d		
Bare steel ^b	Stranded		70	
	Solid round		78	
	Solid tape		75	
Copper coated steel	Solid round	14	50	
	Solid tape		90	
Stainless steel	Solid round	15	78	
	Solid tape		100	
<p>^a Mechanical and electrical characteristics as well as corrosion resistance properties shall meet the requirements of the future EN 50164 series.</p> <p>^b Shall be embedded in concrete for a minimum depth of 50 mm.</p> <p>^c Lattice plate constructed with a minimum total length of the conductor of 4,8 m.</p> <p>^d Different profiles are permitted with a cross-section of 290 mm² and a minimum thickness of 3 mm, e.g. cross profile.</p> <p>^e In case of a Type B arrangement foundation earthing system, the earth electrode shall be correctly connected at least every 5 m with the reinforcement steel.</p> <p>Text deleted</p>				

6 Internal lightning protection system

6.1 General

The internal LPS shall prevent the occurrence of dangerous sparking within the structure to be protected due to lightning current flowing in the external LPS or in other conductive parts of the structure.

Dangerous sparking may occur between the external LPS and other components such as:

- metal installations;
- internal systems;
- external conductive parts and lines connected to the structure.

NOTE 1 Sparking occurring within the structure with danger of explosion is always dangerous. In this case additional protective measures are required which are under consideration (see Annex D).

NOTE 2 For protection against overvoltages of internal systems, refer to [\[C\]](#) EN 62305-4. [\[C\]](#)

Dangerous sparking between different parts can be avoided by means of

- equipotential bonding in accordance with 6.2, or
- electrical insulation between the parts in accordance with 6.3.

6.2 Lightning equipotential bonding

6.2.1 General

Equipotentialization is achieved by interconnecting the LPS with

- metal installations,
- internal systems,
- external conductive parts and lines connected to the structure.

When lightning equipotential bonding is established to internal systems, part of the lightning current may flow into such systems and this effect shall be taken into account.

Interconnecting means can be

- bonding conductors, where the electrical continuity is not provided by natural bonding,
- surge protective devices (SPDs), where direct connections with bonding conductors are not feasible.
- isolating spark gaps (ISGs), where direct connections with bonding conductors are not allowed.

The manner in which lightning equipotential bonding is achieved is important and shall be discussed with the operator of the telecommunication network, the electric power, gas pipes operator, and other operators or authorities concerned, as there may be conflicting requirements.

SPDs shall be installed in such a way that they can be inspected.

NOTE 1 When an LPS is installed, metalwork external to the structure to be protected may be affected. This should be considered when designing such systems. Lightning equipotential bonding for external metalwork may also be necessary.

NOTE 2 Lightning equipotential bonding should be integrated and coordinated with other equipotential bonding in the structure.

6.2.2 Lightning equipotential bonding for metal installations

In the case of an isolated external LPS, lightning equipotential bonding shall be established at ground level only.

For an external LPS which is not isolated, lightning equipotential bonding shall be installed at the following locations:

- a) in the basement or approximately at ground level. Bonding conductors shall be connected to a bonding bar constructed and installed in such a way that it allows easy access for inspection. The bonding bar shall be connected to the earth-termination system. For large structures (typically more than 20 m in length), a ring bonding bar may be used or more than one bonding bar can be installed, provided that they are interconnected;
- b) where insulation requirements are not fulfilled (see 6.3).

Lightning equipotential bonding connections shall be made as direct and straight as possible.

NOTE When lightning equipotential bonding is established to conducting parts of the structure, part of the lightning current may flow into the structure and this effect should be taken into account.

The minimum values of the cross-section of the bonding conductors connecting different bonding bars and of the conductors connecting the bars to the earth-termination system are listed in Table 8.

The minimum values of the cross-section of the bonding conductors connecting internal metal installations to the bonding bars are listed in Table 9.

Table 8 – Minimum dimensions of conductors connecting different bonding bars or connecting bonding bars to the earth-termination system

Class of LPS	Material	Cross-section mm ²
I to IV	Copper	16
	Aluminium	25
	Steel	50

Table 9 – Minimum dimensions of conductors connecting internal metal installations to the bonding bar

Class of LPS	Material	Cross-section mm ²
I to IV	Copper	6
	Aluminium	10
	Steel	16

If insulating pieces are inserted into gas lines or water pipes, inside the structure to be protected they shall, with the agreement of the water and gas supplier, be bridged by ISGs designed for such an operation.

ISGs shall be tested according to the future [C] EN 62561-3 [C] and shall have the following characteristics:

- $I_{imp} \geq k_c I$ where $k_c I$ is the lightning current flowing along the relevant part of the external LPS (see Annex C);
- rated impulse sparkover voltage U_{RIMP} lower than the impulse withstand level of insulation between parts.

6.2.3 Lightning equipotential bonding for external conductive parts

For external conductive parts, lightning equipotential bonding shall be established as near as possible to the point of entry into the structure to be protected.

Bonding conductors shall be capable of withstanding the part I_F of the lightning current flowing through them evaluated in accordance with Annex E of [C] EN 62305-1:2010. [C]

If direct bonding is not acceptable, ISGs with the following characteristics shall be used:

ISGs shall be tested according to the future [C] EN 62561-3 [C] and shall have the following characteristics:

- $I_{imp} \geq I_F$ where I_F is the lightning current flowing along the considered external conductive part (see Annex E of [C] EN 62305-1:2010 [C]);

- the rated impulse sparkover voltage U_{RIMP} lower than the impulse withstand level of insulation between parts.

NOTE When equipotential bonding is required, but an LPS is not required, the earth-termination of the low-voltage electrical installation can be used for this purpose. [C] EN 62305-2 [C] provides information on the conditions where an LPS is not required.

6.2.4 Lightning equipotential bonding for internal systems

It is imperative that lightning equipotential bonding is installed in accordance with 6.2.2 a) and 6.2.2 b).

If cables of internal systems are screened or located in metal conduits, it may be sufficient to bond only these screens and conduits (see Annex B).

NOTE Bonding of screens and conduits may not avoid failure due to overvoltages of equipment connected to the cables. For protection of such equipment refer to [C] EN 62305-4. [C]

If cables of internal systems are neither screened nor located in metal conduits, they shall be bonded via SPDs. In TN systems, PE and PEN conductors shall be bonded to the LPS directly or with an SPD.

Bonding conductors shall have the same current withstand as indicated in 6.2.2 for ISGs.

SPDs shall comply with IEC 61643-1 and IEC 61643-21 and shall have the following characteristics:

- tested with $I_{\text{imp}} \geq k_{\text{c}} I$ where $k_{\text{c}} I$ is the lightning current flowing along the relevant part of the external LPS (see Annex C);
- the protection level U_{p} lower than the impulse withstand level of insulation between parts.

If protection of internal systems against surges is required, a coordinated SPD system conforming to the requirements of Clause 7 of [C] EN 62305-4:2010 [C] shall be used.

6.2.5 Lightning equipotential bonding for lines connected to the structure to be protected

Lightning equipotential bonding for electrical and telecommunication lines shall be installed in accordance with 6.2.3.

All the conductors of each line should be bonded directly or with an SPD. Live conductors shall only be bonded to the bonding bar via an SPD. In TN systems, PE or PEN conductors shall be bonded directly or via an SPD to the bonding bar.

If lines are screened or routed into metal conduits, these screens and conduits shall be bonded. Lightning equipotential bonding for conductors is not necessary, provided that the cross-section S_{c} of these screens or conduits is not lower than the minimum value S_{CMIN} evaluated in accordance with Annex B.

Lightning equipotential bonding of the cable screens or of the conduits shall be performed near the point where they enter the structure.

Bonding conductors shall have the same current withstand as indicated in 6.2.3 for ISGs.

SPDs shall comply with IEC 61643-1 and IEC 61643-21 and shall have the following characteristics:

- tested with $I_{\text{imp}} \geq I_{\text{F}}$ where I_{F} is the lightning current flowing along the lines (see Annex E of [C] EN 62305-1:2010 [C]);

- the protection level U_p lower than the impulse withstand level of insulation between parts.

If protection against surges of internal systems connected to lines entering the structure is required, a coordinated SPD system conforming to the requirements of Clause 7 of [C] EN 62305-4:2010 [C] shall be used.

NOTE When equipotential bonding is required, but an LPS is not required, the earth-termination of the low-voltage electrical installation can be used for this purpose. [C] EN 62305-2 [C] provides information on the conditions where an LPS is not required.

6.3 Electrical insulation of the external LPS

6.3.1 General

Electrical insulation between the air-termination or the down-conductor and the structural metal parts, the metal installations and the internal systems can be achieved by providing a separation distance, s , between the parts. The general equation for the calculation of s is given by:

$$s = \frac{k_i}{k_m} \times k_c \times l \quad (\text{m}) \quad (4)$$

where

k_i depends on the selected class of LPS (see Table 10);

k_m depends on the electrical insulation material (see Table 11);

k_c depends on the (partial) lightning current flowing on the air-termination and the down-conductor (see Table 12 and Annex C);

l is the length, in metres, along the air-termination and the down-conductor from the point, where the separation distance is to be considered, to the nearest equipotential bonding point or the earth termination (see E.6.3 of Annex E).

NOTE The length l along the air-termination can be disregarded in structures with continuous metal roof acting as natural air-termination system.

Table 10 – Isolation of external LPS – Values of coefficient k_i

Class of LPS	k_i
I	0,08
II	0,06
III and IV	0,04

Table 11 – Isolation of external LPS – Values of coefficient k_m

Material	k_m
Air	1
Concrete, bricks, wood	0,5
NOTE 1 When there are several insulating materials in series, it is a good practice to use the lower value for k_m .	
NOTE 2 In using other insulating materials, construction guidance and the value of k_m should be provided by the manufacturer.	

In the case of the lines or external conductive parts entering the structure, it is always necessary to ensure lightning equipotential bonding (by direct connection or connection by SPD) at their point of entry into the structure.

In structures with metallic or electrically continuous connected reinforced concrete framework a separation distance is not required.

The coefficient k_c of the lightning current amongst the air-terminations/down-conductors depends on the class of LPS, on the overall number n , on the position of the down-conductors, on the interconnecting ring conductors and on the type of earth-termination system. The necessary separation distance depends on the voltage drop of the shortest path from the point where the separation distance is to be considered, to the ground electrode or the nearest equipotential bonding point.

6.3.2 Simplified approach

In typical structures for the application of Equation (4), the following conditions have to be considered:

k_c depends on the (partial) lightning current flowing on the down-conductor arrangement (see Table 12 and Annex C);

l is the vertical length, in metres, along the down-conductor, from the point where the separation distance is to be considered, to the nearest equipotential bonding point.

Table 12 – Isolation of external LPS – Approximated values of coefficient k_c

Number of down-conductors n	k_c
1 (only in case of an isolated LPS)	1
2	0,66
3 and more	0,44
NOTE Values of Table 12 apply for all type B earthing arrangements and for type A earthing arrangements, provided that the earth resistance of neighbouring earth electrodes do not differ by more than a factor of 2. If the earth resistances of single earth electrodes differ by more than a factor of 2, $k_c = 1$ is to be assumed.	

Further information on partitioning of the lightning current amongst down-conductors is given in Annex C.

NOTE The simplified approach usually leads to results being on the safe side.

6.3.3 Detailed approach

In an LPS with a meshed air-termination system or interconnected ring conductors, the air-terminations or down-conductors have different values of current flowing down their lengths due to current division. In these cases a more accurate evaluation of the separation distance s may be performed by the following relationship:

$$s = \frac{k_l}{k_m} \times (k_{c1} \times l_1 + k_{c2} \times l_2 + \dots + k_{cn} \times l_n) \quad (5)$$

When the air-terminations or down-conductors have different values of current flowing down their lengths due to interconnecting ring conductors, Figures C.4 and C.5 apply.

NOTE 1 This approach is suitable for evaluation of the separation distance in very large structures or in structures with complex shape.

NOTE 2 For the calculation of the coefficients, k_c on the individual conductors numerical network programs may be used.

7 Maintenance and inspection of an LPS

7.1 General

The effectiveness of any LPS depends on its installation, maintenance, and testing methods used.

Inspections, testing and maintenance shall not be conducted during threat of thunderstorms.

NOTE Detailed information on the inspection and maintenance of LPS are provided in Clause E.7.

7.2 Application of inspections

The objective of the inspections is to ascertain that

- a) the LPS conforms to the design based on this standard,
- b) all components of the LPS are in good condition and capable of performing their designed functions, and that there is no corrosion,
- c) any recently added services or constructions are incorporated into the LPS.

7.3 Order of inspections

Inspections should be made according to 7.2 as follows:

- during the construction of the structure, in order to check the embedded electrodes;
- after the installation of the LPS;
- periodically at such intervals as determined with regard to the nature of the structure to be protected, i.e. corrosion problems and the class of LPS;
NOTE For detailed information see Clause E.7.
- after alterations or repairs, or when it is known that the structure has been struck by lightning.

During the periodic inspection, it is particularly important to check the following:

- deterioration and corrosion of air-termination elements, conductors and connections;
- corrosion of earth electrodes;
- earthing resistance value for the earth-termination system;
- condition of connections, equipotential bonding and fixings.

7.4 Maintenance

Regular inspections are among the fundamental conditions for reliable maintenance of an LPS. The property owner shall be informed of all observed faults and they shall be repaired without delay.

8 Protection measures against injury to living beings due to touch and step voltages

8.1 Protection measures against touch voltages

In certain conditions, the vicinity of the down-conductors of an LPS, may be hazardous to life even if the LPS has been designed and constructed according to the above-mentioned requirements.

The hazard is reduced to a tolerable level if one of the following conditions is fulfilled:

- a) under normal operation conditions there are no persons within 3 m from the down-conductors;
- b) a system of at least 10 down-conductors complying with 5.3.5 is employed;
- c) the contact resistance of the surface layer of the soil, within 3 m of the down-conductor, is not less than 100 k Ω .

NOTE A layer of insulating material, e.g. asphalt, of 5 cm thickness (or a layer of gravel 15 cm thick) generally reduces the hazard to a tolerable level.

If none of these conditions is fulfilled, protection measures shall be adopted against injury to living beings due to touch voltages as follows:

- insulation of the exposed down-conductor is provided giving a 100 kV, 1,2/50 μ s impulse withstand voltage, e.g. at least 3 mm cross-linked polyethylene;
- physical restrictions and/or warning notices to minimize the probability of down-conductors being touched.

Protection measures shall conform to the relevant standards (see ISO 3864-1).

8.2 Protection measures against step voltages

In certain conditions, the vicinity of the down-conductors may be hazardous to life even if the LPS has been designed and constructed according to the above-mentioned rules.

The hazard is reduced to a tolerable level if one of the following conditions is fulfilled:

- a) under normal operation conditions there are no persons within 3 m from the down-conductors;
- b) a system of at least 10 down-conductors complying with 5.3.5 is employed;
- c) the contact resistance of the surface layer of the soil, within 3 m of the down-conductor, is not less than 100 k Ω .

NOTE A layer of insulating material, e.g. asphalt, of 5 cm thickness (or a layer of gravel 15 cm thick) generally reduces the hazard to a tolerable level.

If none of these conditions is fulfilled, protection measures shall be adopted against injury to living beings due to step voltages as follows:

- equipotentialization by means of a meshed earth-termination system;
- physical restrictions and/or warning notices to minimize the probability of access to the dangerous area, within 3 m of the down-conductor.

Protection measures shall conform to the relevant standards (see ISO 3864-1).

Annex A (normative)

Positioning the air-termination system

A.1 Positioning the air-termination system when utilizing the protection angle method

A.1.1 General

The position of the air-termination system is considered to be adequate if the structure to be protected is fully situated within the protected volume provided by the air-termination system.

For the determination of the volume protected only the real physical dimensions of the metal air-termination systems shall be considered.

A.1.2 Volume protected by a vertical rod air-termination system

The volume protected by a vertical rod is assumed to have the shape of a right circular cone with the vertex placed on the air-termination axis, semi-apex angle α , depending on the class of LPS, and on the height of the air-termination system as given in Table 2. Examples of the protected volume are given in Figures A.1 and A.2.

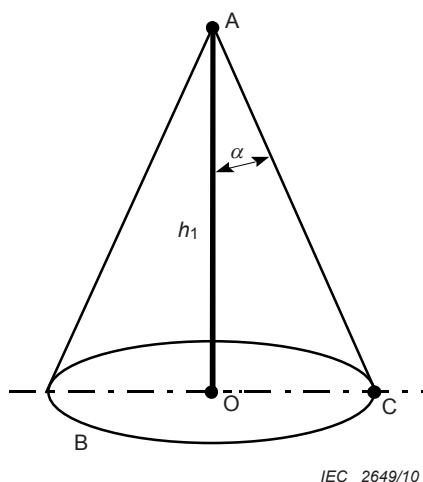

Key

A	tip of an air-termination rod
B	reference plane
OC	radius of protected area
h_1	height of an air-termination rod above the reference plane of the area to be protected
α	protection angle according to Table 2

Figure A.1 – Volume protected by a vertical air-termination rod

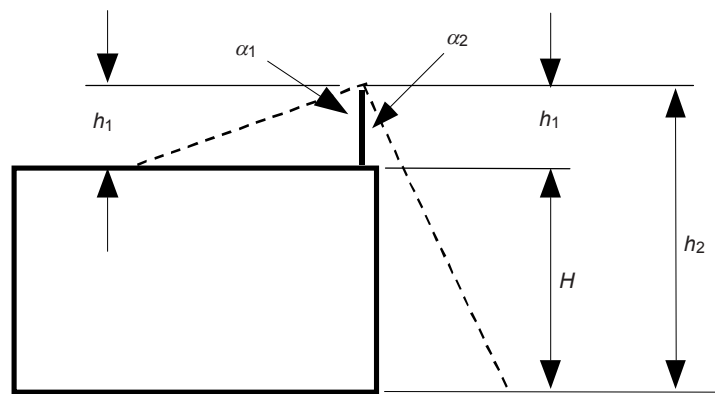

IEC 2650/10

Key

h_1 physical height of an air-termination rod

NOTE The protection angle α_1 corresponds to the air-termination height h_1 , being the height above the roof surface to be protected; the protection angle α_2 corresponds to the height $h_2 = h_1 + H$ the ground being the reference plane; α_1 is related to h_1 and α_2 is related to h_2 .

Figure A.2 – Volume protected by a vertical air-termination rod

A.1.3 Volume protected by a wire air-termination system

The volume protected by a wire is defined by the composition of the volume protected by virtual vertical rods having vertexes on the wire. Examples of the protected volume are given in Figure A.3.

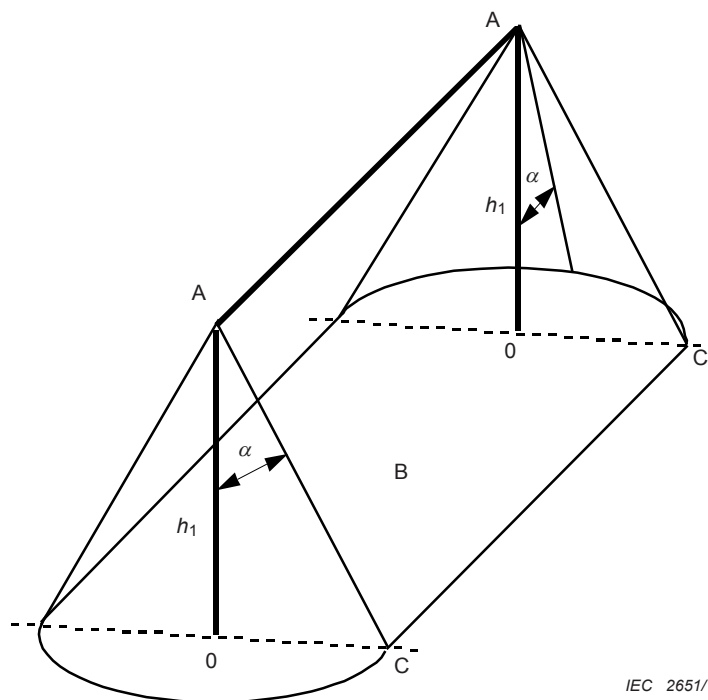

IEC 2651/10

NOTE See Figure A.1 for key.

Figure A.3 – Volume protected by a wire air-termination system

A.1.4 Volume protected by wires combined in a mesh

The volume protected by wires combined in a mesh is defined by a combination of the protected volume determined by the single conductors forming the mesh.

Examples of the volume protected by wires combined in a mesh is given in Figures A.4 and A.5.

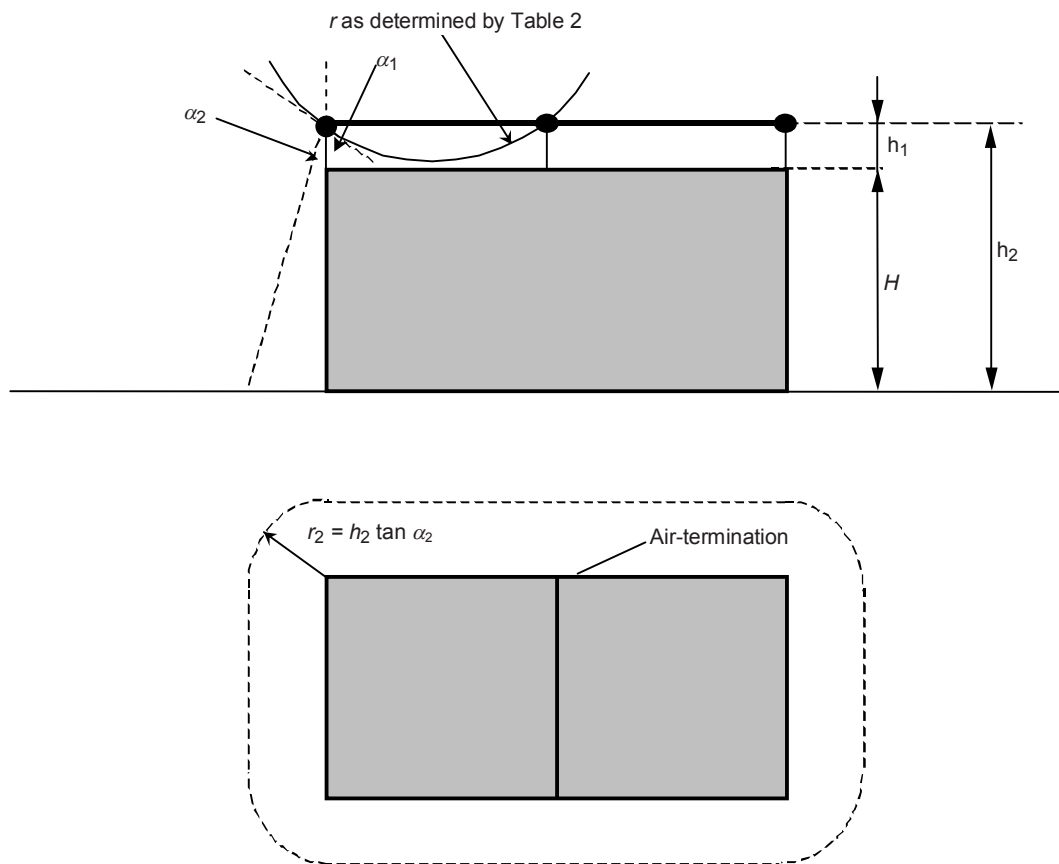

IEC 2652/10

Figure A.4 – Volume protected by isolated wires combined in a mesh according to the protection angle method and rolling sphere method

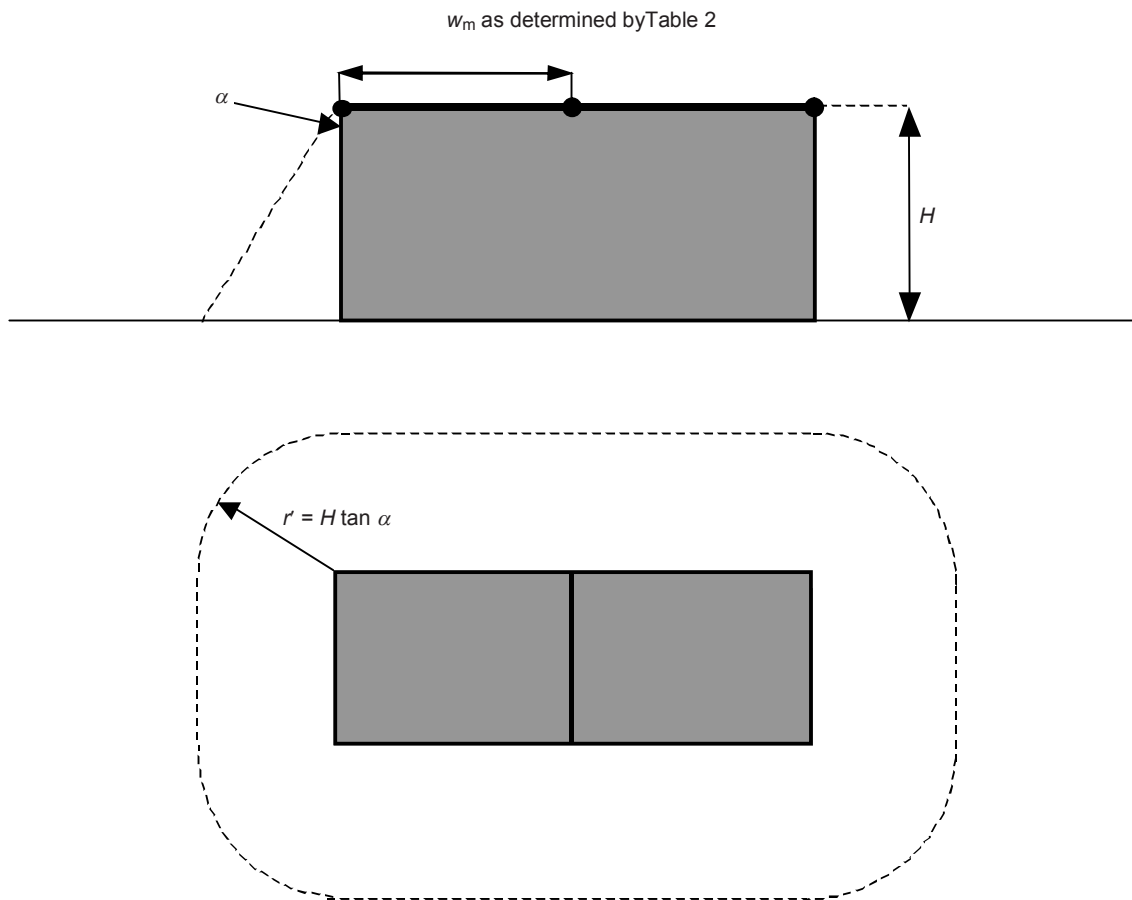

IEC 2653/10

Figure A.5 – Volume protected by non-isolated wires combined in a mesh according to the mesh method and the protection angle method

A.2 Positioning of the air-termination system utilizing the rolling sphere method

Applying this method, the positioning of the air-termination system is adequate if no point of the structure to be protected comes into contact with a sphere with radius, r , depending on the class of LPS (see Table 2), rolling around and on top of the structure in all possible directions. In this way, the sphere only touches the air-termination system (see Figure A.6).

On all structures higher than the rolling sphere radius r , flashes to the side of structure may occur. Each lateral point of the structure touched by the rolling sphere is a possible point of strike. However, the probability for flashes to the sides is generally negligible for structures lower than 60 m.

For taller structures, the major part of all flashes will hit the top, horizontal leading edges and corners of the structure. Only a few per cent of all flashes will be to the side of the structure.

Moreover, observation data show that the probability of flashes to the sides decreases rapidly as the height of the point of strike on tall structures when measured from the ground. Therefore consideration should be given to install a lateral air-termination system on the upper part of tall structures (typically the top 20 % of the height of the structure). In this case

the rolling sphere method will be applied only to the positioning of the air-termination system of the upper part of the structure.

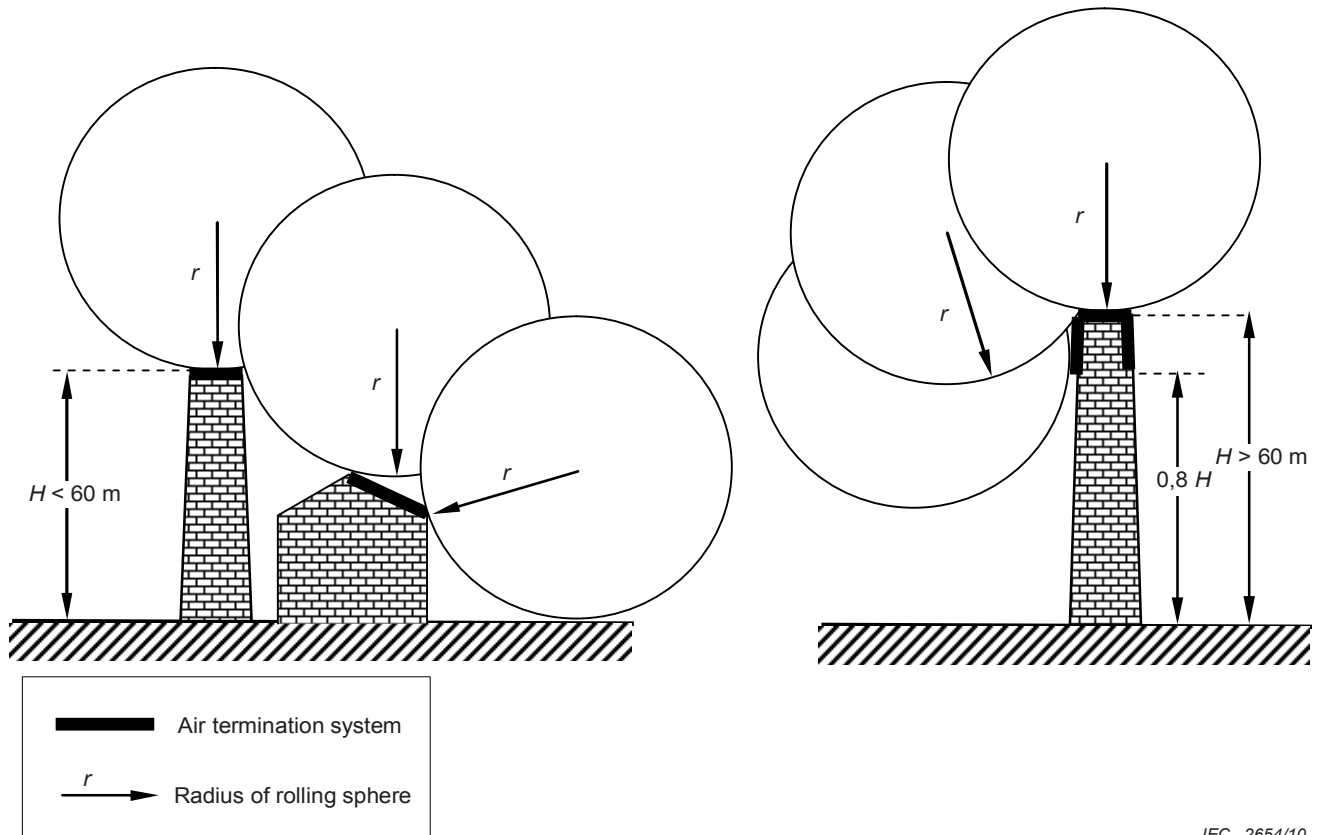

NOTE The rolling sphere radius, r , should comply with the selected class of LPS (see Table 2).

Figure A.6 – Design of an air-termination system according to the rolling sphere method

A.3 Positioning of the air-termination system utilizing the mesh method

For the purposes of protecting flat surfaces, a mesh is considered to protect the whole surface, dependent upon all of the following conditions being fulfilled:

- a) Air-termination conductors are positioned
 - on roof edge lines,
 - on roof overhangs,
 - on roof ridge lines, if the slope of the roof exceeds 1/10.

NOTE 1 The mesh method is suitable for horizontal and inclined roofs with no curvature.

NOTE 2 The mesh method is suitable for flat lateral surfaces to protect against side flashes.

NOTE 3 If the slope of the roof exceeds 1/10, parallel air-termination conductors, instead of a mesh, may be used provided the distance between the conductors is not greater than the required mesh width.

- b) The mesh dimensions of the air-termination network are not greater than the values given in Table 2.
- c) The network of the air-termination system is constructed in such a way that the lightning current will always encounter at least two distinct metal routes to earth-termination.
- d) No metal installation protrudes outside the volume protected by air-termination systems.

NOTE 4 Further information can be found in Annex E.

- e) The air-termination conductors follow, as far as possible, the shortest and most direct route.

Annex B (normative)

Minimum cross-section of the entering cable screen in order to avoid dangerous sparking

The overvoltages between the active conductors and the screen of a cable may cause dangerous sparking due to the lightning current carried by the screen. The overvoltages depend on the material, the dimensions of the screen, and the length and positioning of the cable.

The minimum value S_{CMIN} (in mm²) of the cross-sectional area of the screen to avoid dangerous sparking is given by:

$$S_{\text{CMIN}} = (I_{\text{F}} \times \rho_{\text{C}} \times L_{\text{C}} \times 10^6) / U_{\text{W}} \quad (\text{mm}^2) \quad (\text{B.1})$$

where

I_{F} is the current flowing on the screen, in kA;

ρ_{C} is the resistivity of the screen, in Ωm ;

L_{C} is the cable length, in m (see Table B.1);

U_{W} is the impulse withstand voltage of the electrical/electronic system fed by the cable, in kV.

Table B.1 – Cable length to be considered according to the condition of the screen

Condition of the screen	L_{C}
In contact with a soil with resistivity ρ (Ωm)	$L_{\text{C}} \leq 8 \times \sqrt{\rho}$
Insulated from the soil or in air	L_{C} is the distance between the structure and the closest earthing point of the screen

NOTE It should be ascertained whether an unacceptable temperature rise for the insulation of the line could occur when the lightning current flows along the line shield or the line conductors. For detailed information, see [EN 62305-4](#).

The limits of the current are given:

– for copper shielded cables, by $I_{\text{F}} = 8 \times S_{\text{C}}$; and

– for unshielded cables, by $I_{\text{F}} = 8 \times n' \times S'_{\text{C}}$

where

I_{F} is the current on the screen, in kA;

n' is the number of conductors;

S_{C} is the cross-section of the screen, in mm²;

S'_{C} is the cross-section of each conductor, in mm².

Annex C
(informative)

Evaluation of the separation distance s

The partitioning coefficient k_c of the lightning current amongst the air-terminations/down-conductors depends on the type of air-termination system, on the overall number, n , and on the position of the down-conductors and on the interconnecting ring conductors, and on the type of earth-termination system.

NOTE 1 The necessary separation distance depends on the voltage drop of the shortest path from the point where the separation distance is to be considered, to the nearest equipotential bonding point.

NOTE 2 The information in this annex applies for all type B earthing arrangements and for type A earthing arrangements, provided that the earth resistance of neighbouring earth electrodes do not differ by more than a factor of 2. If the earth resistances of single earth electrodes differ by more than a factor of 2, $k_c = 1$ is to be assumed.

When the air-terminations or down-conductors have the constant value of current flowing over the lengths of the conductors, Figures C.1, C.2 and C.3 apply (see 6.3.2. Simplified approach).

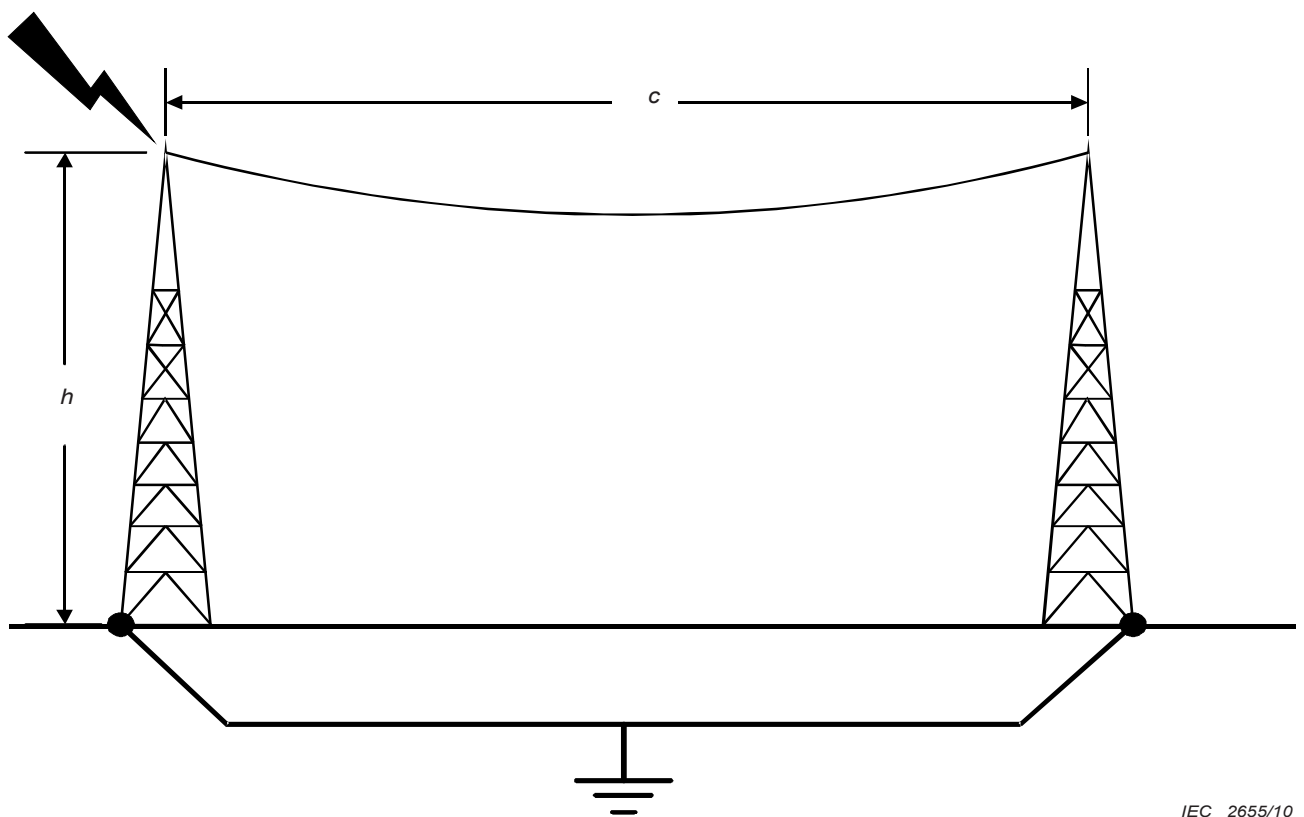

IEC 2655/10

$$k_c = \frac{h + c}{2h + c}$$

Figure C.1 – Values of coefficient k_c in the case of a wire air-termination system

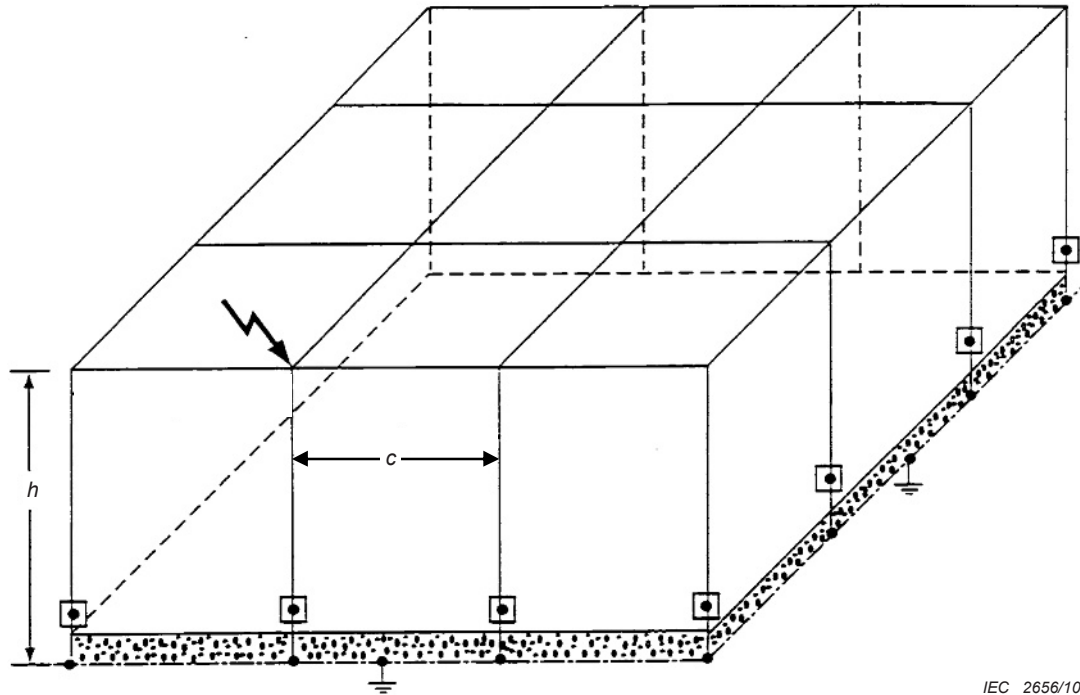

$$k_c = \frac{1}{2n} + 0,1 + 0,2 \times \sqrt[3]{\frac{c}{h}}$$

Key

- n total number of down-conductors
- c distance of a down-conductor to the next down-conductor
- h spacing (or height) between ring conductors

NOTE 1 The equation for k_c is an approximation for cubic structures and for $n \geq 4$. The values of h and c are assumed to be in the range of 3 m to 20 m.

NOTE 2 If internal down-conductors exist, they should be taken into account in the number n .

Figure C.2 – Values of coefficient k_c in the case of multiple down-conductors system

	$\frac{c}{h}$	0,33	0,50	1,00	2,00	
	k_c	0,57	0,60	0,66	0,75	c Distance from the nearest down-conductor along the ridge
	k_c	0,47	0,52	0,62	0,73	h Length of the down-conductor from the ridge to the next equipotential bonding point or to the earth-termination system
	k_c	0,44	0,50	0,62	0,73	The values of k_c , shown in the table, refer to the down-conductors represented by a thick line and a strike point
	k_c	0,44	0,50	0,62	0,73	The location of the down-conductor (to be considered for k_c) is to be compared with the figure representative for that down-conductor
	k_c	0,40	0,43	0,50	0,60	The actual relation c/h is to be determined. If this relation ranges between two values in the columns, k_c may be found by interpolation
	k_c	0,40	0,43	0,50	0,60	NOTE 1 Additional down-conductors with more distance than illustrated in the figures are of insignificant influence.
	k_c	0,40	0,43	0,50	0,60	NOTE 2 In case of inter-connecting ring-conductors below the ridge see Figure C.4.
	k_c	0,35	0,39	0,47	0,59	NOTE 3 The values are determined by simple calculation of parallel impedances following the formula of Figure C.1.
	k_c	0,31	0,35	0,45	0,58	

Figure C.3 (continued overleaf)

	k_c	0,31	0,33	0,37	0,41
	k_c	0,28	0,33	0,37	0,41
	k_c	0,27	0,33	0,37	0,41
	k_c	0,23	0,25	0,30	0,35
	k_c	0,21	0,24	0,29	0,35
	k_c	0,20	0,23	0,29	0,35

Figure C.3 – Values of coefficient k_c in the case of a sloped roof with air-termination on the ridge

$$d_a \geq s_a = \frac{k_i}{k_m} \times k_{c1} \times l_a$$

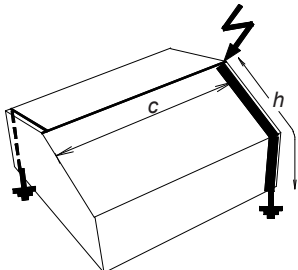
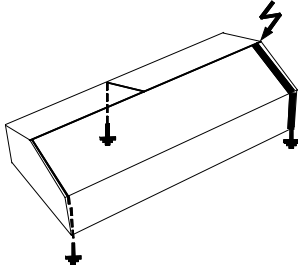
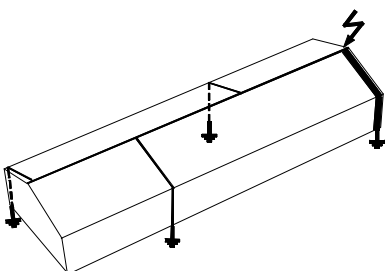
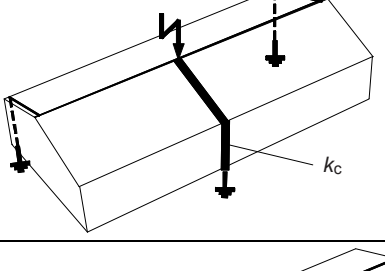
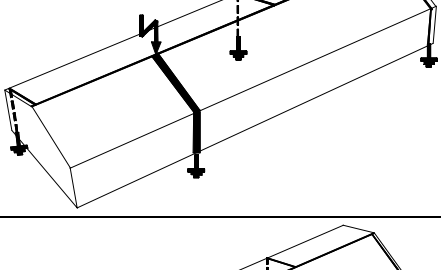
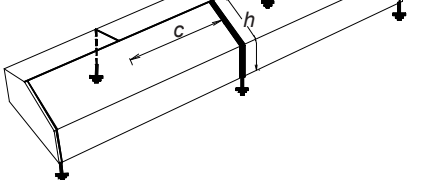
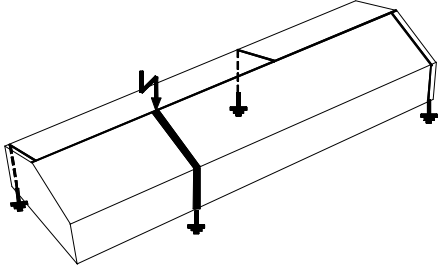
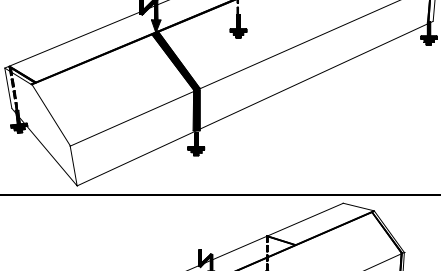
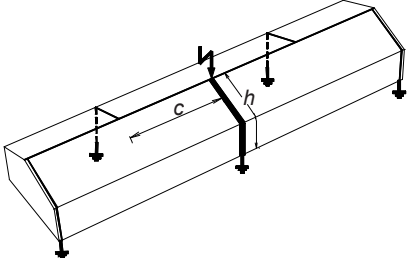
$$d_b \geq s_b = \frac{k_i}{k_m} \times k_{c2} \times l_b$$

$$d_c \geq s_c = \frac{k_i}{k_m} \times k_{c3} \times l_c$$

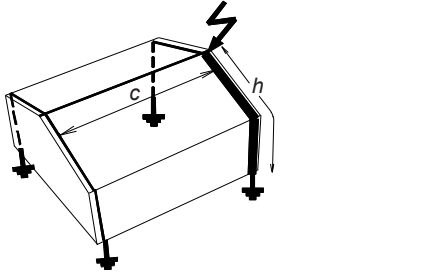
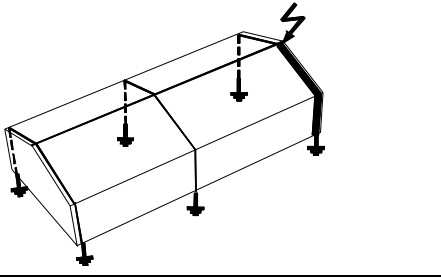
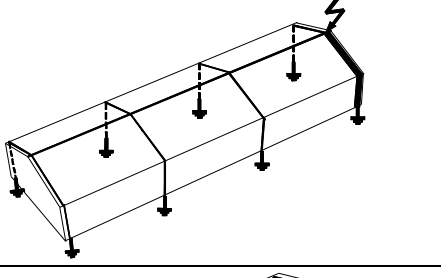
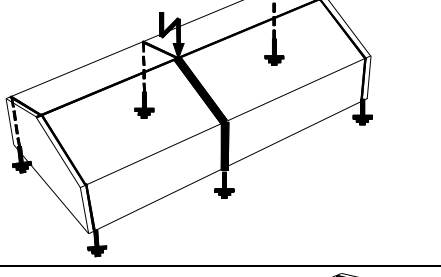
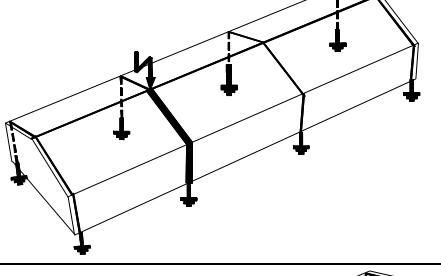
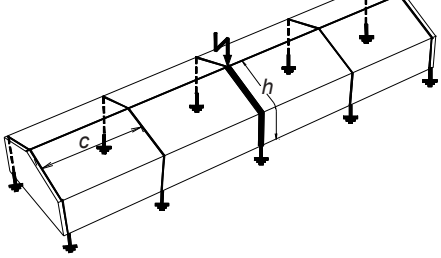
$$d_e \geq s_e = \frac{k_i}{k_m} \times k_{c4} \times l_e$$

$$d_f \geq s_f = \frac{k_i}{k_m} \times (k_{c1} \times l_f + k_{c2} \times h_2)$$

$$d_g \geq s_g = \frac{k_i}{k_m} \times (k_{c2} \times l_g + k_{c3} \times h_3 + k_{c4} \times h_4)$$

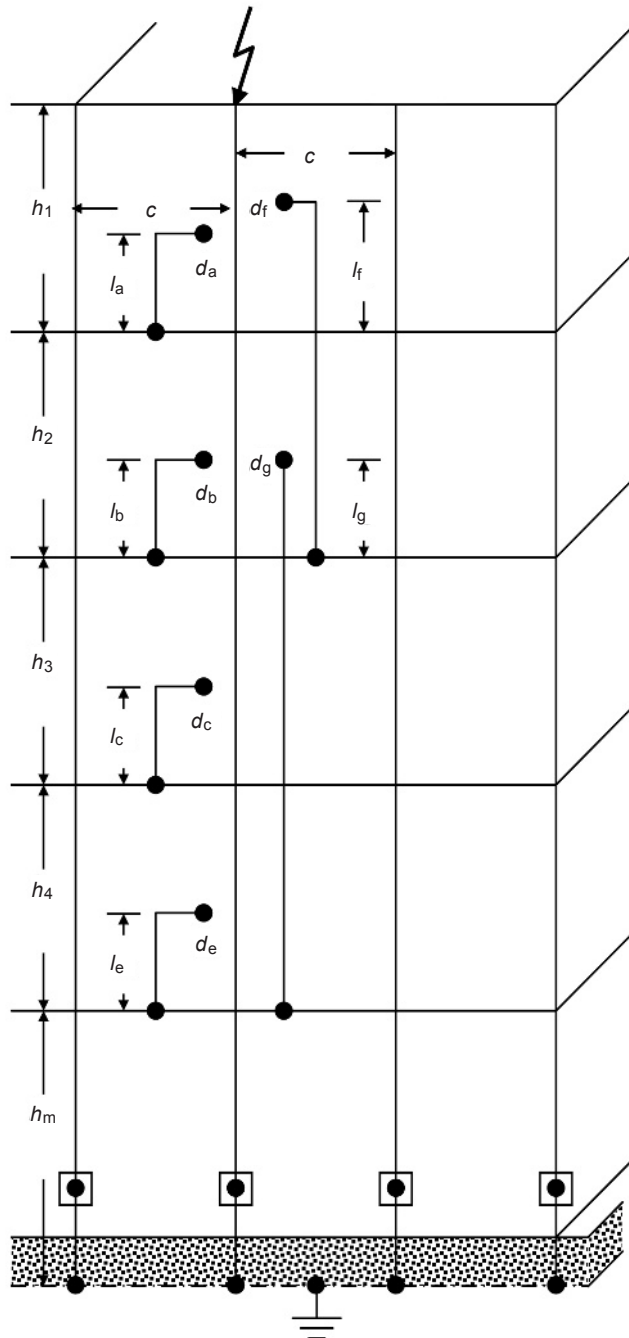

$$k_{c1} = \frac{1}{2n} + 0,1 + 0,2 \times \sqrt[3]{\frac{c}{h_1}}$$

$$k_{c2} = \frac{1}{n} + 0,1$$

$$k_{c3} = \frac{1}{n} + 0,01$$

$$k_{c4} = \frac{1}{n}$$

$$k_{cm} = k_{c4} = \frac{1}{n}$$

Key

- n* total number of down-conductors
- c* spacing between down-conductors
- h* spacing (height) between ring conductors
- m* total number of levels
- d* distance to the nearest down-conductor
- l* height above the bonding point

IEC 2657/10

NOTE If internal down-conductors exist, they should be taken into account in the number *n*.

Figure C.4 – Examples of calculation of the separation distance in the case of multiple down-conductors with an interconnecting ring of the down-conductors at each level

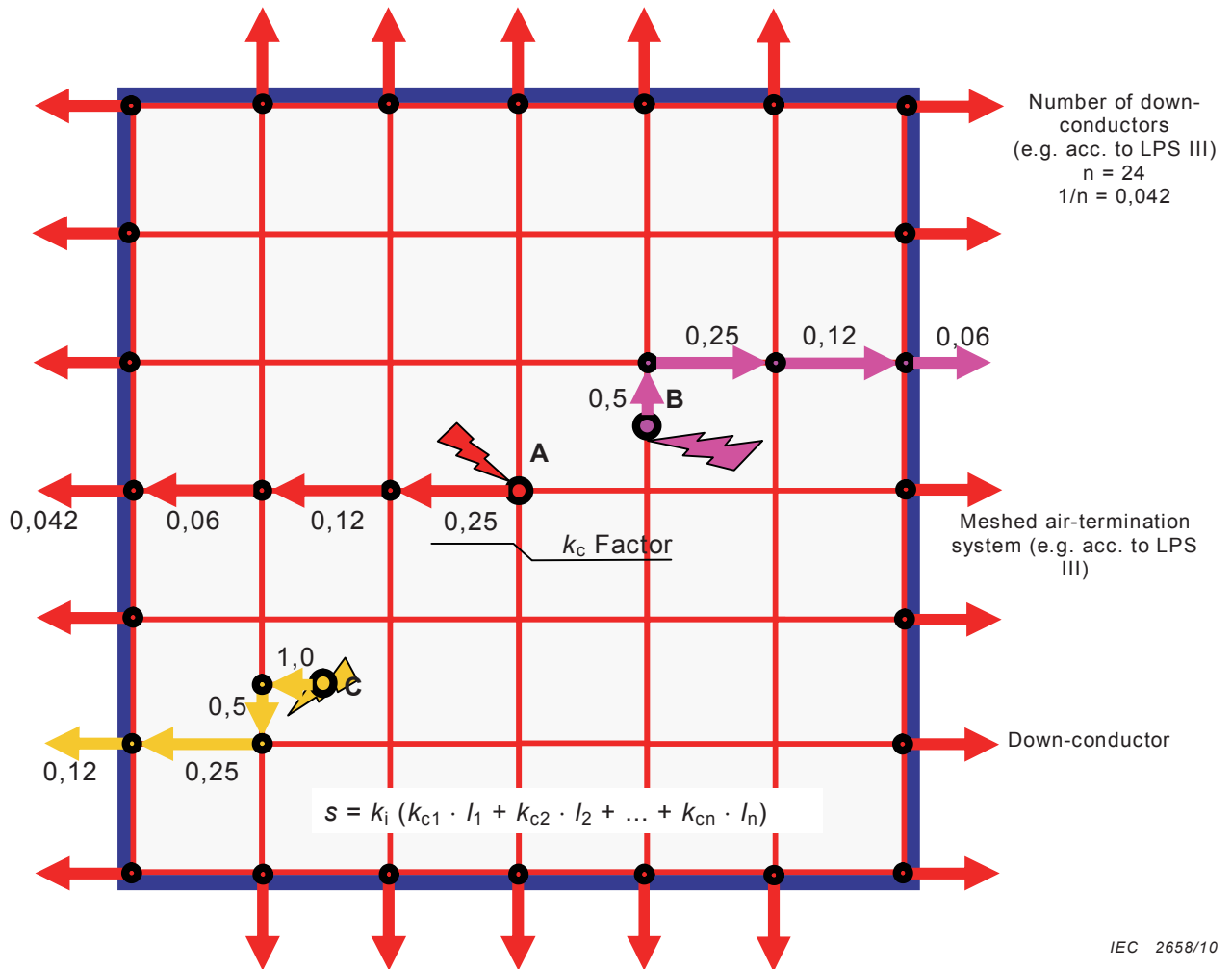

Key

A, B, C injection points

NOTE 1 Rules for current partitioning:

a) Injection point

Current is divided by the number of possible current paths at the injection point into the meshed air-termination system.

b) Further junctions (joints)

Current is reduced by 50 % at any further joint of the air-termination mesh.

c) Down-conductor

Current is again reduced by 50 %, but the value of k_c must not be less than $1/n$.

(n ... total number of down-conductors)

NOTE 2 Values of k_c have to be considered from the point of strike to the edge of the roof. The path along the roof edge to the down-conductor does not need to be considered. The values of k_c along the down-conductors depend on the value of k_c of the connected air-termination at the edge of the roof.

NOTE 3 As shown above, if there are fewer meshes from the point of strike to the edge of the roof, only the relevant values of k_c , beginning from the point where the proximity distance is to be considered, have to be used.

NOTE 4 If internal down-conductors exist, they should be taken into account in evaluating the number n .

Figure C.5 – Values of coefficient k_c in the case of a meshed air-termination system, with a multiple down-conductors system

Annex D (normative)

Additional information for LPS in the case of structures with a risk of explosion

D.1 General

This annex supplies additional requirements for the design, construction, extension and modification of lightning protection systems for structures with a risk of explosion.

NOTE Information provided in this annex is based on practically proven configurations of lightning protection systems installed in applications where a danger of explosion exists. The authority having jurisdiction may give other requirements.

D.2 Additional terms and definitions

In addition to the terms and definitions of Clause 3, the terms and definitions of IEC 60079-14:2007, as well as the following terms and definitions, are applicable to this annex.

D.2.1

solid explosive material

solid chemical compound, mixture, or device with explosion as its primary or common purpose

D.2.2

zone 0

place in which an explosive atmosphere consisting of a mixture of air and flammable substances in the form of gas, vapour or mist is present continuously or for long periods or frequently

[IEC 60050-426:2008, 426-03-03, modified] ^[4]

D.2.3

zone 1

place in which an explosive atmosphere consisting of a mixture of air and flammable substances in the form of gas, vapour or mist is likely to occur in normal operation occasionally

[IEC 60050-426:2008, 426-03-04, modified] ^[4]

D.2.4

zone 2

place in which an explosive atmosphere consisting of a mixture of air and flammable substances in the form of gas, vapour or mist is not likely to occur in normal operation but, if it does occur, will persist for a short period only

NOTE 1 In this definition, the word "persist" means the total time for which the flammable atmosphere will exist. This will normally comprise the total of the duration of the release, plus the time taken for the flammable atmosphere to disperse after the release has stopped.

NOTE 2 Indications of the frequency of the occurrence and duration may be taken from codes relating to specific industries or applications.

[IEC 60050-426:2008, 426-03-05, modified] ^[4]

D.2.5
zone 20

place in which an explosive atmosphere, in the form of a cloud of combustible dust in air, is present continuously, or for long periods, or frequently

[IEC 60079-10-2:2009, 6.2, modified]

D.2.6
zone 21

place in which an explosive atmosphere in the form of a cloud of combustible dust in air, is likely to occur in normal operation occasionally

[IEC 60079-10-2:2009, 6.2, modified]

D.2.7
zone 22

place in which an explosive atmosphere in the form of a cloud of combustible dust in air is not likely to occur in normal operation but, if it does occur, will persist for a short period only

[IEC 60079-10-2:2009, 6.2, modified]

D.3 Basic requirements

D.3.1 General

The lightning protection system shall be designed and installed in such a manner that, in case of a direct lightning flash, there are no melting or spraying effects except at the striking point.

NOTE 1 Sparks or damaging impact at the striking point may also be experienced. This should be taken into consideration in the determination of air-termination device locations. Down-conductors should be installed in such a way that the auto-ignition temperature given by the source of the relative hazardous area are not exceeded in those applications where it is not possible to install down-conductors outside of the hazardous area.

NOTE 2 Due to a lightning stroke, an impact on electrical equipment cannot be avoided in every case.

D.3.2 Required information

The lightning protection system installer/designer shall be provided with drawings of the plant(s) to be protected, with the areas in which solid explosive material will be handled or stored or hazardous areas according to IEC 60079-10-1 and IEC 60079-10-2 appropriately marked.

D.3.3 Earthing

A type B arrangement for the earth-termination system, according to 5.4.2.2, is preferred for all lightning protection systems for structures with danger of explosion.

NOTE The construction of a structure may provide the effective equivalent of the ring conductor of type B arrangement (for example metallic storage tanks).

The earthing resistance of earth-termination systems for structures containing solid explosive materials and explosive mixtures shall be as low as possible and not greater than 10 Ω .

D.3.4 Equipotential bonding

Common equipotential bonding shall be provided for the lightning protection system according to 6.2 and for installations in explosion endangered areas according to IEC 60079-10-1 and IEC 60079-10-2.

D.4 Structures containing solid explosive material

The design of lightning protection for structures containing solid explosive material shall take into consideration the sensitivity of the material in the configuration in which it is used or stored. For instance, some insensitive bulk explosive material may not require any additional consideration other than those contained within this annex. However, there are some configurations of sensitive explosive materials that may be sensitive to rapidly changing electrical fields and/or radiated by lightning impulsive electromagnetic field. It may be necessary to establish additional bonding or shielding requirements for such applications.

For structures containing solid explosive materials, an isolated external LPS (as defined in 5.1.2) is encouraged. Structures totally contained within a metallic shell of at least 5 mm thickness steel or equivalent (7 mm for aluminium structures) may be considered protected by a natural air-termination system as defined by 5.2.5. The earthing requirements of 5.4 are applicable for such structures.

NOTE Where hot spot or ignition problems may arise, it should be verified that the temperature rise of the inner surface at the point of strike does not constitute a danger.

Surge protective devices (SPDs) shall be provided as part of the LPS for all locations where explosive material is present. Where practicable, SPDs shall be positioned outside locations where solid explosive material is present. SPDs positioned inside locations where exposed explosives or explosive dust is present shall be of explosion-proof type.

D.5 Structures containing hazardous areas

D.5.1 General

All parts of the external LPS (air-termination and down-conductors) shall be at least 1 m away from a hazardous area, where possible. Where this is not possible, conductors passing within a hazardous zone should preferably be continuous or connections shall be made in accordance with 5.5.3.

Accidental loosening of connections in hazardous areas shall be prevented.

Where a hazardous area is located directly under a metal sheet that may be punctured by lightning (see 5.2.5) air-termination shall be provided in accordance with the requirements of 5.2.

D.5.1.1 Surge suppression

Surge protective devices shall be positioned outside the hazardous area where practicable. Surge protective devices positioned inside the hazardous area shall be approved for the hazardous area in which they are installed.

D.5.1.2 Equipotential bonding

Beside connections according to Tables 7 and 8, piping, which is connected so that it is electrically conductive according to 5.3.5 may also be used as connections.

Above ground metal piping outside process units shall be earthed at least every 30 m. Connections to piping shall be of such a kind that, in the instance of a lightning current passage, there is no sparking. Suitable connections to piping are welded-on lugs or bolts or tap holes in the flanges for taking up screws. Connections by means of clips are only allowed if, in the instance of lightning currents, ignition protection is proved by tests and procedures are utilized to ensure the reliability of the connection. Junctions shall be provided for the joining of connection and earthing leads to containers, metal construction parts, drums and tanks.

Lightning equipotential bonding connections between the lightning protection system and other installations/structures/equipment will be carried out with the agreement of the system

operator. Lightning equipotential bonding connections utilizing spark gaps may not be made without the agreement of the system operator. Such devices shall be suitable for the environment in which they are installed.

D.5.2 Structures containing zones 2 and 22

Structures where areas defined as zones 2 and 22 exist may not require supplemental protection measures.

For outdoor facilities made of metal (e.g. columns, reactors, containers with areas containing zones 2 and 22) of thickness and material meeting the requirements of Table 3, the following applies:

- air-termination devices and down-conductors are not required;
- facilities shall be earthed according to Clause 5.

D.5.3 Structures containing zones 1 and 21

For structures where areas defined as zones 1 and 21 exist, the requirements for zones 2 and 22 apply with the following additions:

- if there are insulation pieces in piping, the operator shall determine the protective measures. For instance, a disruptive discharge can be avoided by the use of explosion-protected, isolating spark gaps;
- the isolating spark gaps and the insulation pieces shall be inserted outside the hazardous areas.

D.5.4 Structures containing zones 0 and 20

For structures where areas defined as zones 0 and 20 exist, the requirements of D.5.3 apply, supplemented by the recommendations given in this clause as applicable.

For outdoor facilities with areas defined as zones 0 and 20, the requirements for zones 1, 2, 21 and 22 apply with the following additions:

- electrical equipment inside tanks containing flammable liquids shall be suitable for this use. Measures for lightning protection shall be taken according to the type of construction;
- closed metal containers with areas defined as zones 0 and 20 inside shall have a wall thickness in accordance with Table 3 at the possible lightning striking points provided that the temperature rise of the inner surface at the point of strike does not constitute a danger. In the case of thinner walls, air-termination devices shall be installed.

D.5.5 Specific applications

D.5.5.1 Filling stations

At filling stations for cars, ships, etc, with hazardous areas, the metal piping shall be earthed according to Clause 5. Piping shall be connected with steel constructions and rails, where existing (if necessary via isolating spark gaps approved for the hazardous area in which it is installed), to take into account railway currents, stray currents, electrical train fuses, cathodic-corrosion-protected systems and the like.

D.5.5.2 Storage tanks

Certain types of structures used for the storage of liquids that can produce flammable vapours or used to store flammable gases are essentially self-protecting (contained totally within continuous metallic containers having a thickness of not less than 5 mm of steel or 7 mm of

aluminium, with no spark gaps) and require no additional protection provided that the temperature rise of the inner surface at the point of strike does not constitute a danger.

Similarly, soil-covered tanks and piping do not require the installation of air-termination devices. Instrumentation or electrics used inside this equipment shall be approved for this service. Measures for lightning protection shall be taken according to the type of construction.

The tanks in tank farms (for example refineries and tank stores) the earthing of every tank at one point only is sufficient. The tanks shall be connected with each other. Besides connections according to Tables 8 and 9, piping which is connected so that it is electrically-conductive according to 5.3.5 may also be used as connections.

NOTE In some countries additional requirements may exist.

Isolated tanks or containers shall be earthed according to Clause 5, depending on the greatest horizontal dimension (diameter or length):

- up to 20 m, once;
- over 20 m, twice.

In the case of floating-roof tanks, the floating-roof shall be effectively bonded to the main tank shell. The design of the seals and shunts and their relative locations needs to be carefully considered so that the risk of any ignition of a possible explosive mixture by incendiary sparking is reduced to the lowest level practicable. When a rolling ladder is fitted, a flexible bonding conductor of 35 mm width and minimum thickness of 3 mm shall be applied across the ladder hinges, between the ladder and the top of the tank and between the ladder and the floating roof. When a rolling ladder is not fitted to the floating-roof tank, one or more, (depending on the size of the tank), flexible bonding conductors of 35 mm width and minimum thickness of 3 mm, or equivalent, shall be applied between the tank shell and the floating roof. The bonding conductors shall be arranged so that they cannot form a re-entrant loop. On floating roof tanks, multiple shunt connections shall be provided between the floating-roof and the tank shell at about 1,5 m intervals around the roof periphery. Material selection is decided by product and/or environmental requirements. Alternative means of providing an adequate conductive connection between the floating roof and tank shell for impulse currents associated with lightning discharges are only allowed if proved by tests and if procedures are utilized to ensure the reliability of the connection.

D.5.5.3 Piping network

Above-ground metal piping network inside a production facilities but outside the process units should be connected every 30 m with the earthing system, or should be earthed by a surface earth electrode or an earth rod. Isolating supports of the piping should not be considered.

D.6 Maintenance and inspection

D.6.1 General

All installed LPS used to protect structures with risk of explosion shall be properly maintained and inspected. Additional requirements to those reported in Clause 7 are needed for the inspection and maintenance of LPS in structures with a risk of explosion.

D.6.2 General requirements

A maintenance and inspection plan shall be developed for the installed protection systems. Maintenance guidelines of the LPS shall be provided or added to the existing schedule at the completion of LPS installation.

D.6.3 Qualifications

Only qualified personnel having the necessary training and expertise shall be permitted to maintain, inspect and test the LPS system of explosives facilities.

Inspection requires personnel who

- a) have technical knowledge and understanding of the theoretical and practical requirements for installation in hazardous areas and for LPS equipment and installations,
- b) understand the requirements of visual and complete inspections as they relate to the installed LPS equipment and installations.

NOTE Competencies and training may be identified in relevant national training and assessment frameworks.

D.6.4 Inspection requirements

To ensure that the installations are maintained in a satisfactory condition for continued use, either

- a) regular periodic inspections, and/or
- b) continuous supervision by skilled personnel,

and, where necessary, maintenance shall be carried out.

Following any adjustment, maintenance, repair, reclamation, modification or replacement, the equipment or relevant parts of equipment concerned shall be inspected.

D.6.4.1 Regular periodic inspections

The personnel who carry out the regular periodic inspections will need to be sufficiently independent of the demands of the maintenance activities, for example, so as not to prejudice their ability to reliably report the findings of the inspection.

NOTE It is not a requirement that such personnel are members of an external independent organization.

D.6.4.2 Concept of continuous supervision by skilled personnel

The objective of continuous supervision is to enable the early detection of arising faults and their subsequent repair. It makes use of existing skilled personnel who are in attendance at the installation in the course of their normal work (e.g. erection work, alterations, inspections, maintenance work, checking for faults, cleaning work, control operations, making terminal connections and disconnections, functional tests, measurements) and who use their skill to detect faults and changes at an early stage.

Where an installation is visited on a regular basis, in the normal course of work, by skilled personnel who, in addition to satisfying the requirements of a) and b) of D.6.3, are

- a) aware of the process and the environmental implications on the deterioration of the specific equipment in the installation, and
- b) required to carry out visual and/or complete inspections as part of their normal work schedule as well as detailed inspections

then it may be possible to dispense with regular periodic inspection and utilize the frequent presence of the skilled personnel to ensure the on-going integrity of the equipment.

The use of continuous supervision by skilled personnel does not remove the requirement for initial and sample inspections.

D.6.5 Electrical testing requirements

The lightning protection system shall be tested electrically

- a) every 12 (+ 2) months, or
- b) to predict accurately an appropriate periodic inspection interval is a complex issue. The grade of inspection and the interval between periodic inspections shall be determined taking account of the type of equipment, manufacturer's guidance, if any, the factors governing its deterioration and the results of previous inspections.

Where inspection grades and intervals have been established for similar equipment, plants and environments, this experience shall be used in determining the inspection strategy.

Intervals between periodic inspections exceeding three years should be based on an assessment including relevant information.

Maintenance and inspection of the LPS should be carried out together with maintenance and inspection of all other electrical installations in hazardous areas and shall be incorporated into the maintenance schedule.

Instruments used for testing shall be in accordance with IEC 61557-4.

The DC resistance of any single object bonded to the lightning protection system shall not exceed 0,2 Ω .

The test shall be conducted in accordance with the appropriate test equipment manufacturer's instructions.

D.6.6 Earthing resistance test methods

Only those instruments designed specifically for earth resistance testing shall be permitted for use in this application.

Test instruments shall be properly maintained and calibrated in accordance with manufacturer's instructions.

If possible, a three-point earth resistance test method shall be used to measure the resistance to earth for explosives facilities.

D.6.7 Surge protection

Lightning surge protection devices (and their means of isolation, if provided) shall be inspected in accordance with manufacturer's instruction at intervals not exceeding 12 months or whenever electrical testing of the LPS is performed. SPDs shall also be inspected after any suspected lightning strike to the structure.

D.6.8 Repairs

Maintenance personnel shall ensure that repairs of all discrepancies found during inspections are made in an acceptable time frame.

D.6.9 Records and documentation

Any indication of damage produced by a lightning strike to a structure or its LPS shall be immediately documented and reported.

Historical records of maintenance and inspections shall be maintained for each facility for the purpose of trend analysis.

Annex E (informative)

Guidelines for the design, construction, maintenance and inspection of lightning protection systems

E.1 General

This annex provides guidance on the physical design and construction, maintenance and inspection of an LPS conforming to this standard.

This annex should be used and is only valid together with other parts of this standard.

Examples are given of protection techniques which have the approval of international experts.

NOTE The examples given in this annex illustrate one possible method of achieving protection. Other methods may be equally valid.

E.2 Structure of this annex

In this annex the main clause numbers mirror the clause numbers of the main document. This gives an easy reference between the two parts. Not all clauses are necessarily mirrored.

To achieve this goal, Clause E.3 is not used in this annex.

E.3 Vacant

E.4 Design of lightning protection systems (LPS)

E.4.1 General remarks

The construction of an LPS for an existing structure should always be weighed against other measures of lightning protection conforming to this standard which give the same protection level for reduced costs. For selection of the most suitable protection measures, [C] EN 62305-2 [C] applies.

The LPS should be designed and installed by LPS designers and installers.

The designer and installer of an LPS should be capable of assessing both the electrical and mechanical effects of the lightning discharge and be familiar with the general principles of electromagnetic compatibility (EMC).

Furthermore, the lightning protection designer should be capable of assessing corrosion effects and judging when it is necessary to seek expert assistance.

The lightning protection designer and installer should be trained in the proper design and installation of the LPS components in accordance with the requirements of this standard and the national rules regulating construction work and the building of structures.

The functions of an LPS designer and installer may be performed by the same person. A thorough knowledge of the relevant standards and several years of experience is required to become a specialized designer or installer.

Planning, implementation and testing of an LPS encompasses a number of technical fields and makes demands for coordination by all parties involved with the structure to ensure the achievement of the selected lightning protection level with minimum cost and lowest possible effort. The management of the LPS should be efficient if the steps in Figure E.1 are followed. Quality assurance measures are of great importance; in particular for structures including extensive electrical and electronic installations.

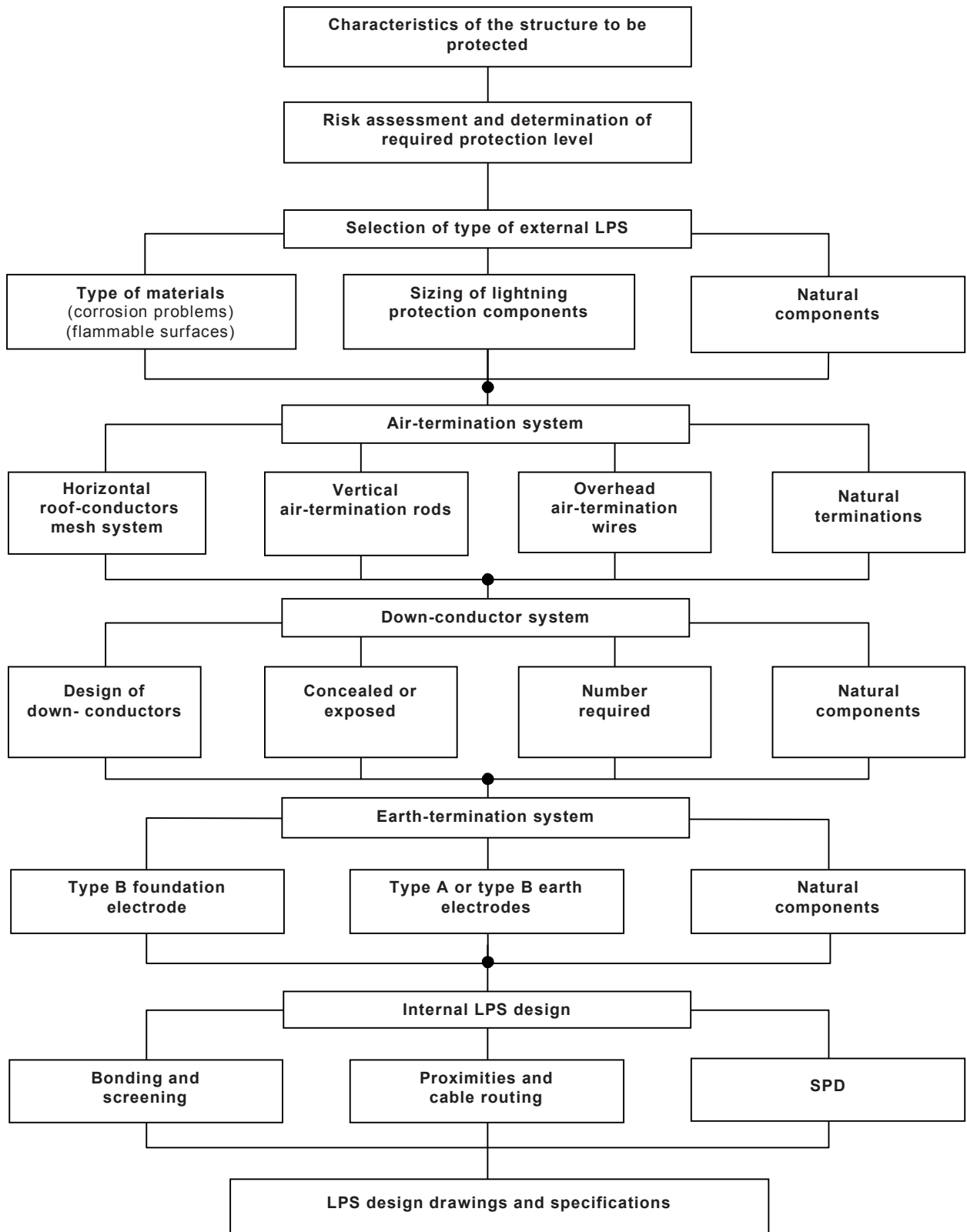

IEC 2659/10

NOTE Interfaces ● require the full cooperation of the architect, engineer and lightning protection designer.

Figure E.1 – LPS design flow diagram

The quality assurance measures extend from the planning stage, in which all drawings should be approved, through the LPS construction stage during which all essential parts of the LPS inaccessible for inspection after the construction works have been finished should be checked. Quality assurance measures continue through the acceptance stage, when final measurements on the LPS should be performed together with the completion of the final test documentation and finally through the entire lifetime of the LPS, by specifying careful periodic inspections in accordance with the maintenance programme.

Where modifications are made to a structure or its installations, a check should be made to determine whether the existing lightning protection still conforms to this standard. If it is found that the protection is inadequate, improvements should be implemented without delay.

It is recommended that the materials, extent and dimensions of the air-termination system, down-conductors, earth-termination system, bonding, components, etc. should conform to this standard.

E.4.2 Design of the LPS

E.4.2.1 Planning procedure

Before any detailed design work on the LPS is commenced, the lightning protection designer should, where reasonably practical, obtain basic information regarding the function, general design, construction and location of the structure.

Where the LPS has not already been specified by the licensing authority, insurer or purchaser, the lightning protection designer should determine whether or not to protect the structure with an LPS by following the procedures for risk assessment given in **EN 62305-2**.

E.4.2.2 Consultation

E.4.2.2.1 General information

In the design and construction stages of a new structure, the LPS designer, LPS installer and all other persons responsible for installations in the structure or for regulations pertaining to the use of the structure (e.g. purchaser, architect and builder) should be in consultation regularly.

The flow diagram given in Figure E.1 will facilitate the rational design of an LPS.

In the design and construction stages of an LPS for an existing structure, consultations should be held as far as reasonably practical with the persons responsible for the structure, its use, installations and incoming services.

The consultations may have to be arranged through the owner, the building contractor of the structure or their appointed representative. For existing structures, the LPS designer should provide drawings which should be modified by the LPS installer, where necessary.

Regular consultations between the involved parties should result in an effective LPS at the lowest possible cost. For example, the coordination of LPS design work with construction work will often do away with the need for some bonding conductors and reduce the length of those which are necessary. Building costs are often reduced substantially by the provision of common routes for various installations within a structure.

Consultation is important throughout all stages of the construction of a structure as modifications to the LPS may be required due to changes in the structure design. Consultation is also necessary so that arrangements can be agreed to facilitate inspection of the parts of the LPS which will become inaccessible for visual control after the structure is completed. In these consultations, the location of all connections between natural

components and the LPS should be determined. Architects are normally available to arrange and coordinate consultation meetings for new building projects.

E.4.2.2.2 The principal consulting parties

The lightning protection designer should hold relevant technical consultations with all parties involved in the design and construction of the structure, including the owner of the structure.

Particular areas of responsibility for the total installation of the LPS should be defined by the LPS designer in conjunction with the architect, electrical contractor, building contractor, the LPS installer (LPS supplier) and, where relevant, a historical adviser and the owner or owner's representative.

The clarification of responsibility for the various parties involved in the management of the design and construction of the LPS is of particular importance. An example might be where the waterproofing of the structure is punctured by roof-mounted LPS components or by earth electrode connection conductors made below the structure foundation.

E.4.2.2.2.1 Architect

Agreement should be reached with the architect on the following items:

- a) routing of all LPS conductors;
- b) materials for LPS components;
- c) details of all metal pipes, gutters, rails and similar items;
- d) details of any equipment, apparatus, plant installations, etc. to be installed on, within or near the structure which may require the moving of installations or may require bonding to the LPS because of the separation distance. Examples of installations are alarm systems, security systems, internal telecommunication systems, signal and data processing systems, radio and TV circuits;
- e) the extent of any buried conductive service which could affect the positioning of the earth-termination network and be required to be placed at a safe distance from the LPS;
- f) the general area available for the earth-termination network;
- g) the extent of the work and the division of responsibility for primary fixings of the LPS to the structure. For example, those affecting the water tightness of the fabric (chiefly roofing), etc;
- h) conductive materials to be used in the structure, especially any continuous metal which may have to be bonded to the LPS, for example stanchions, reinforcing steel and metal services either entering, leaving, or within the structure;
- i) the visual impact of the LPS;
- j) the impact of the LPS on the fabric of the structure;
- k) the location of the connection points to the reinforcing steel, especially where they penetrate external conductive parts (pipes, cable shields, etc.);
- l) the connection the LPS to the LPS of adjacent buildings.

E.4.2.2.2.2 Public utilities

Bonding of incoming services to the LPS directly or, if this is not possible, through isolating spark gaps or SPD should be discussed with the operator or authorities concerned, as there may be conflicting requirements.

E.4.2.2.2.3 Fire and safety authorities

Agreement should be reached with the fire and safety authorities on the following items:

- the positioning of alarm and fire extinguishing system components;

- routes, construction material and sealing of ducts;
- the method of protection to be used in the case of a structure with a flammable roof.

E.4.2.2.2.4 Electronic system and external antenna installers

Agreement with the electronic system and antenna installer should be reached on the following items:

- the isolating or bonding of aerial supports and conductive shields of cables to the LPS;
- the routing of aerial cables and internal network;
- installation of surge protective devices.

E.4.2.2.2.5 Builder and installer

Agreement on the following items should be reached between the builder, installer, and those responsible for construction of the structure and its technical equipment:

- a) the form, position and number of primary fixings of the LPS to be provided by the builder;
- b) any fixings provided by the LPS designer (or the LPS contractor or the LPS supplier) to be installed by the builder;
- c) the position of LPS conductors to be placed beneath the structure;
- d) whether any components of the LPS are to be used during the construction phase, for example the permanent earth-termination network could be used for earthing cranes, hoists and other metallic items during construction work on the site;
- e) for steel-framed structures, the number and position of stanchions and the form of fixing to be made for the connection of earth-terminations and other components of the LPS;
- f) whether metal coverings, where used, are suitable as components of the LPS;
- g) the method of ensuring the electrical continuity of the individual parts of the coverings and their method of connecting them to the rest of the LPS where metal coverings are suitable as components of the LPS;
- h) the nature and location of services entering the structure above and below ground including conveyor systems, television and radio aerials and their metal supports, metal flues and window cleaning gear;
- i) coordination of the structure's LPS earth-termination system with the bonding of power and communication services;
- j) the position and number of flag masts, roof-level plant rooms, for example lift motor rooms, ventilation, heating and air-conditioning plant rooms, water tanks and other salient features;
- k) the construction to be employed for roofs and walls in order to determine appropriate methods of fixing LPS conductors, specifically with a view to maintaining the water-tightness of the structure;
- l) the provision of holes through the structure to allow free passage of LPS down-conductors;
- m) the provision of bonding connections to steel frames, reinforcement bars and other conductive parts of the structure;
- n) the frequency of inspection of LPS components which will become inaccessible, for example steel reinforcing bars encapsulated in concrete;
- o) the most suitable choice of metal for the conductors taking account of corrosion, especially at the point of contact between dissimilar metals;
- p) accessibility of test joints, provision of protection by non-metallic casings against mechanical damage or pilferage, lowering of flag masts or other movable objects, facilities for periodic inspection especially for chimneys;

- q) the preparation of drawings incorporating the above details and showing the positions of all conductors and main components;
- r) the location of the connection points to the reinforcing steel.

E.4.2.3 Electrical and mechanical requirements

E.4.2.3.1 Electrical design

The LPS designer should select the appropriate LPS to obtain the most efficient construction. This means consideration of the architectural design of the structure to determine whether an isolated or non-isolated LPS, or a combination of both types of lightning protection, should be used.

Soil resistivity tests should be performed preferably prior to finalizing the design of an LPS and should take into consideration the seasonal variations of soil resistivity.

During the completion of the basic electrical design of the LPS, the use of suitable conductive parts of the structure should be considered as natural components of the LPS to enhance or act as essential components of the LPS.

It is the responsibility of the LPS designer to evaluate the electrical and physical properties of natural components of the LPS and to ensure that they conform to the minimum requirements of this standard.

The use of metal reinforcing, such as steel-reinforced concrete, as lightning protection conductors requires careful consideration, and knowledge of the national construction standards applicable to the structure to be protected. The steel skeleton of reinforced concrete may be used as LPS conductors or may be used as a conductive shielding layer to reduce the electromagnetic fields generated by lightning in the structure as the lightning currents are conducted through an isolated LPS. This LPS design makes protection easier, in particular for special structures containing extensive electrical and electronic installations.

A stringent construction specification for down-conductors is required in order to meet the minimum requirements for natural components given in 5.3.5.

E.4.2.3.2 Mechanical design

The lightning protection designer should consult with the persons responsible for the structure on mechanical design matters following the completion of the electrical design.

Aesthetic considerations are particularly important as well as the correct selection of materials to limit the risk of corrosion.

The minimum size of lightning protection components for the various parts of the LPS are listed in Tables 3, 6, 7, 8 and 9.

The materials used for the LPS components are listed in Table 5.

NOTE For selection of other components, such as rods and clamps, reference [C] should be made to the future EN 50164 [C] series. This will ensure that temperature rise and mechanical strength of such components are taken into account.

Where deviations are made from the dimensions and materials specified in Tables 5, 6 and 7, using the lightning discharge electrical parameters specified for the selected class of LPS given in Table 1, the lightning protection designer or installer should predict the temperature rise of lightning conductors under discharge conditions and dimension the conductors accordingly.

When excessive temperature rise is a concern for the surface on which the components are to be attached (because it is flammable or has a low melting point), either larger conductor cross-sections should be specified or other safety precautions should be considered, such as the use of stand-off fittings or the insertion of fire-resistant layers.

The LPS designer should identify all corrosion problem areas and specify appropriate measures.

The corrosion effects on the LPS may be reduced either by increases in material size, by using corrosion resistive components, or by taking other corrosion protection measures.

The LPS designer and LPS installer should specify conductor fasteners and fixtures which will withstand the electrodynamic forces of lightning current in the conductors and also allow for the expansion and contraction of conductors due to the increase in temperature that occurs.

This \square should be achieved by using components tested according to the future EN 50164 \square series.

E.4.2.3.3 Structure with a cantilevered part

To reduce the probability of a person standing under a cantilevered construction from becoming an alternate path for lightning current flowing in the down-conductor running on the cantilevered wall, the actual distance, d , in metres should satisfy the following condition:

$$d > 2,5 + s \quad (\text{E.1})$$

where s is the separation distance in metres calculated in accordance with 6.3.

The value 2,5 is representative of the height at the tips of a man's fingers when he stretches his arm vertically (see Figure E.2).

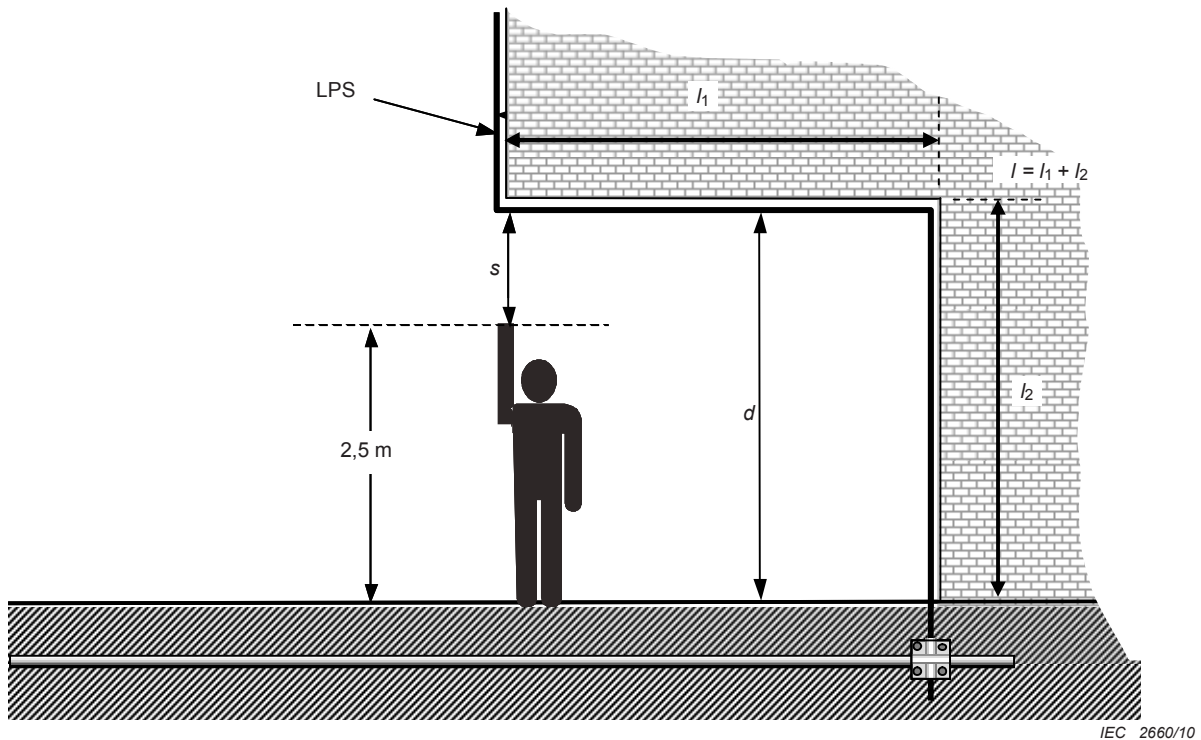

Key

- d actual distance $> s$
- s separation distance according to 6.3
- l length for the evaluation of separation distance s

NOTE The height of the person with raised hand is taken to be 2,5 m.

Figure E.2 – LPS design for a cantilevered part of a structure

Loops in a conductor as shown in Figure E.2 can produce high inductive voltage drops, which can cause a lightning discharge to pass through a structure wall thereby causing damage.

If the conditions in 6.3 are not met, arrangements should be made for direct routing through the structure at the points of re-entrant lightning conductor loops for those conditions shown in Figure E.2.

E.4.3 Reinforced concrete structures

E.4.3.1 General

Industrial structures frequently comprise sections of reinforced concrete which are produced on site. In many other cases, parts of the structure may consist of prefabricated concrete units or steel parts.

Steel reinforcement in reinforced concrete structures conforming to 4.3 may be used as a natural component of the LPS.

Such natural components must fulfil the requirements of:

- down-conductors according to 5.3;
- earth-termination networks according to 5.4.

The requirement of a maximum overall resistance of $0,2 \Omega$ can be checked by measuring the resistance between the air-termination system and a ground plate at ground level using

testing equipment suitable for the application capable of measuring in a four lead configuration (two measuring leads and two sensing leads) as illustrated in Figure E.3. The injected measuring current should be in the order of about 10 A.

NOTE 1 When access to test areas or routing of test cables are difficult, dedicated bar from high to low may be provided in order to carry out testing at each point. The total resistance of joints plus the resistance of down-conductor can then be calculated.

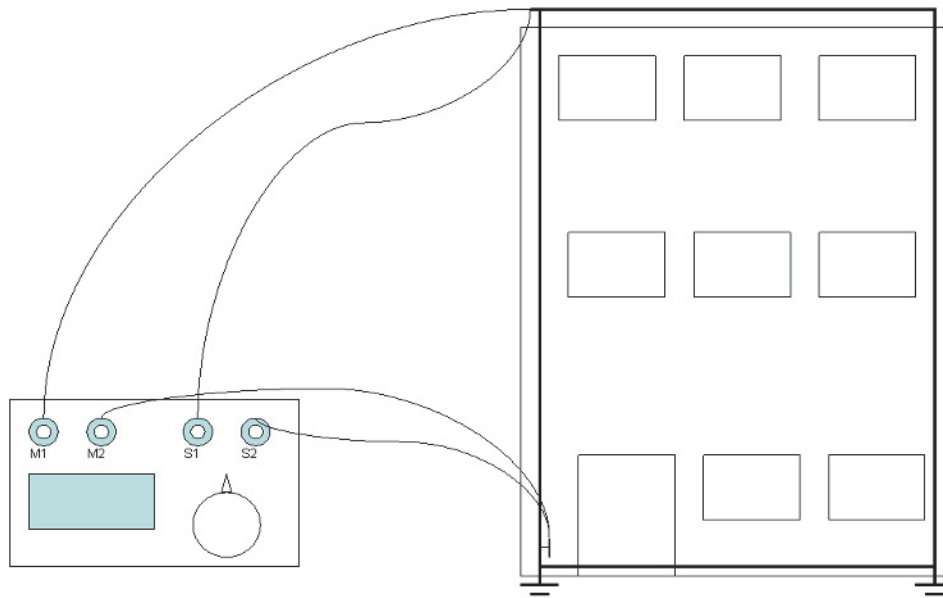

IEC 2661/10

Figure E.3 – Measuring the overall electrical resistance

Moreover, the conductive steel reinforcement in concrete, when properly used, should form the cage for potential equalization of the internal LPS according to 6.2.

Furthermore, the steel reinforcement of the structure, if adequate, may serve as an electromagnetic shield, which assists in protecting electrical and electronic equipment from interference caused by lightning electromagnetic fields according to [C] EN 62305-4. [C]

If the reinforcement of the concrete and any other steel constructions of a structure are connected both externally and internally so that the electrical continuity conforms to 4.3, effective protection may be achieved against physical damage.

The current injected into the reinforcing rods is assumed to flow through a large number of parallel paths. The impedance of the resulting mesh is thus low and, as a consequence, the voltage drop due to the lightning current is also low. The magnetic field generated by the current in the reinforcing steel mesh is weak due to the low current density and the parallel current paths generating opposing electromagnetic fields. Interference with neighbouring internal electrical conductors is correspondingly reduced.

NOTE 2 For protection against electromagnetic interference, see [C] EN 62305-4 [C] and IEC/TR 61000-5-2 [5].

When a room is totally enclosed by steel-reinforced concrete walls whose electrical continuity conforms to 4.3, the magnetic field due to lightning current flowing through the reinforcement in the vicinity of the walls is lower than that in a room of a structure protected with conventional down-conductors. Owing to the lower induced voltages in conductor loops installed inside the room, protection against failures of internal systems may be easily improved.

After the construction phase, it is nearly impossible to determine the layout and construction of the reinforcement steel. Therefore, the layout of the reinforcement steel for the purpose of lightning protection should be very well documented. This can be done utilizing drawings, descriptions and photographs taken during the construction.

E.4.3.2 Utilization of reinforcement in concrete

Bonding conductors or grounding plates should be furnished in order to provide reliable electrical connection to the reinforcement steel.

Conductive frames that, for example, are attached to the structure may be used as natural LPS conductors and as connection points for the internal equipotential bonding system.

A practical example is the use of foundation anchors or foundation rails of machines, apparatus or housings, to achieve potential equalization. Figure E.4 illustrates the arrangement of the reinforcement and the bonding bars in an industrial structure.

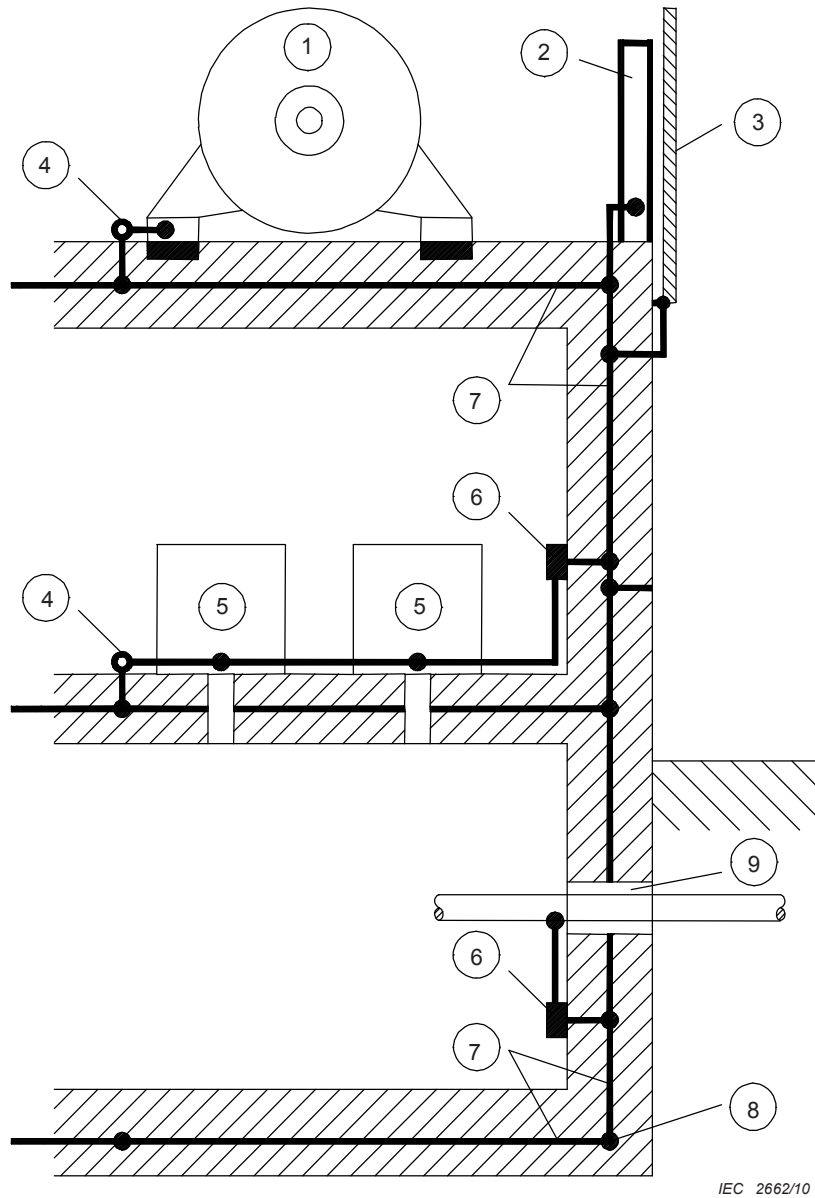

IEC 2662/10

Key

- | | |
|--------------------------------------|---|
| 1 electrical power equipment | 6 bonding bar |
| 2 steel girder | 7 steel reinforcement in concrete (with superimposed mesh conductors) |
| 3 metal covering of the facade | 8 foundation earth electrode |
| 4 bonding joint | 9 common inlet for different services |
| 5 electrical or electronic equipment | |

Figure E.4 – Equipotential bonding in a structure with a steel reinforcement

The location of bonding terminations in the structure should be specified at an early planning stage in the design of the LPS and should be made known to the civil works contractor.

The building contractor should be consulted to determine whether welding to the reinforcing rods is permitted, whether clamping is possible or whether additional conductors should be installed. All necessary work should be performed and inspected prior to pouring of the concrete (i.e. planning of the LPS should be carried out in conjunction with the design of the structure).

E.4.3.3 Welding or clamping to the steel-reinforcing rods

The continuity of the reinforcing rods should be established by clamping or welding.

NOTE Clamps conforming to the future CEN EN 50164 series of standards should be used. CEN

Welding to the reinforcing rods is only permitted if the civil works designer consents. The reinforcing rods should be welded over a length not less than 50 mm (see Figure E.5).

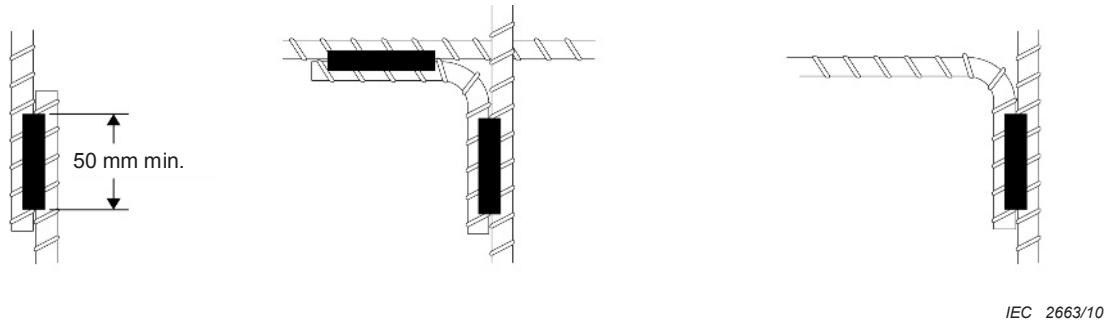

Figure E.5a – Welded joints (suitable for lightning current and EMC purposes)

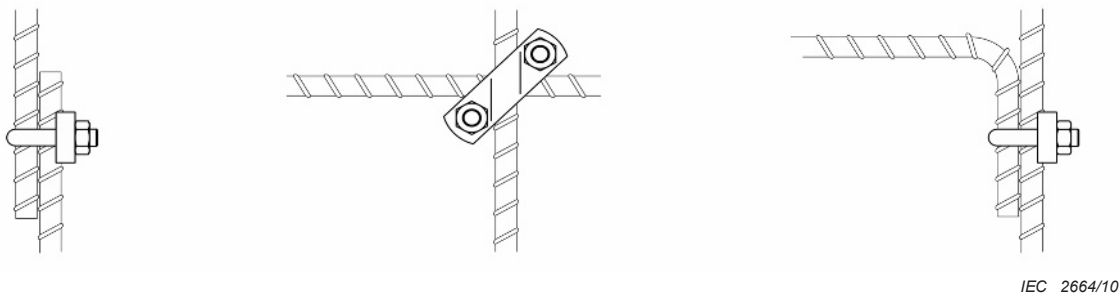

Figure E.5b – Clamped joints to future CEN EN 50164 CEN (suitable for lightning current and EMC purposes)

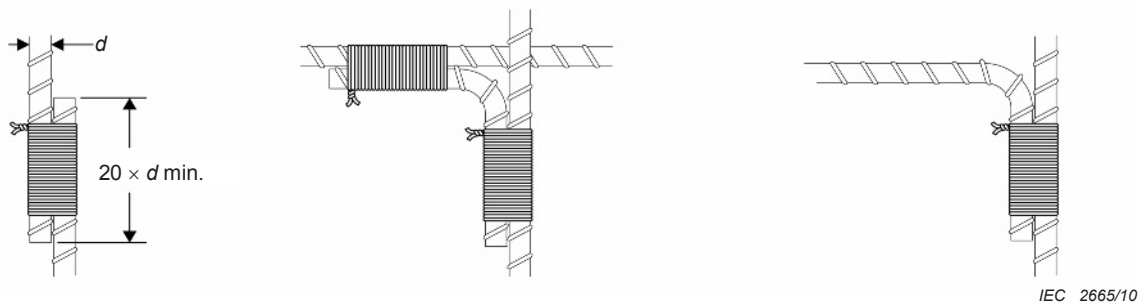

Figure E.5c – Bound joints (suitable for lightning current and EMC purposes)

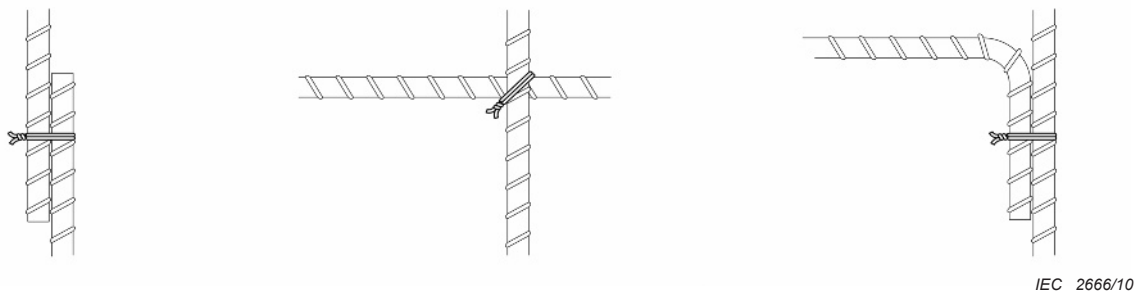

Figure E.5d – Lashed joints (suitable for EMC purposes only)

Figure E.5 – Typical methods of joining reinforcing rods in concrete (where permitted)

The connection to outside components of the lightning protection system should be established by a reinforcement rod brought out through the concrete at a designated location or by a connecting rod or ground plate passing through the concrete which is welded or clamped to the reinforcing rods.

Where joints between the reinforcing rods in concrete and the bonding conductor are made by means of clamping, two bonding conductors (or one bonding conductor with two clamps to different reinforcing bars) should always be used for safety, since the joints cannot be inspected after the concrete has set. If the bonding conductor and reinforcing rod are dissimilar metals, then the joint area should be completely sealed with a moisture inhibiting compound.

Figure E.6 shows clamps used for joints for reinforcing rods and solid tape conductors. Figure E.7 shows details for connection of an external system to reinforcing rods.

The bonding conductors should be dimensioned for the proportion of lightning current flowing at the bonding point (see Tables 8 and 9).

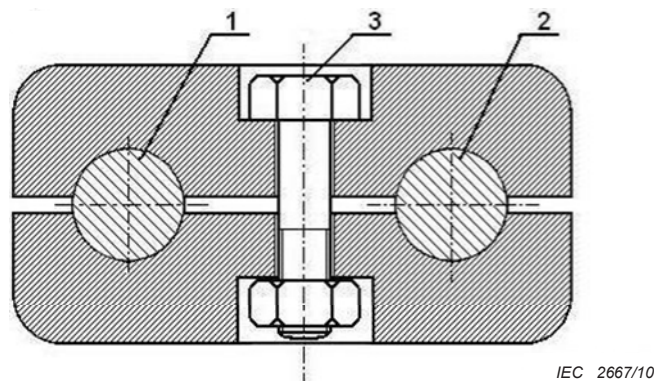

Figure E.6a – Circular conductor to a reinforcing rod

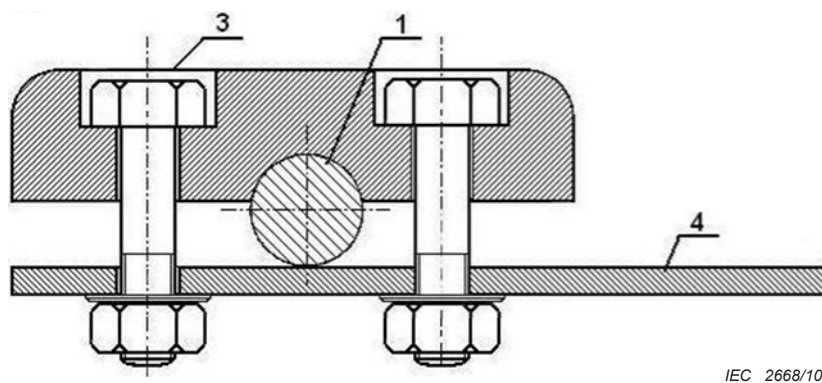

Figure E.6b – Solid tape conductor to a reinforcing rod

Key

- 1 reinforcing rod
- 2 circular conductor
- 3 screw
- 4 tape conductor

Figure E.6 – Example of clamps used as joints between reinforcing rods and conductors

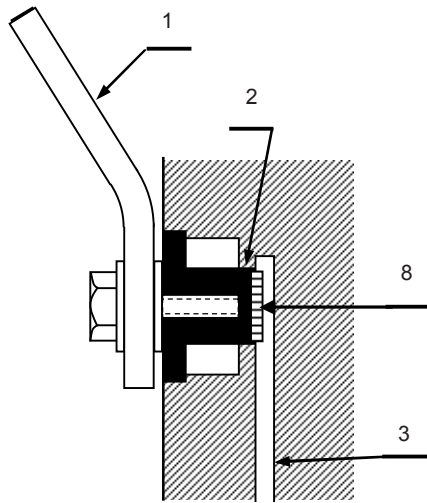

Figure E.7a

IEC 2669/10

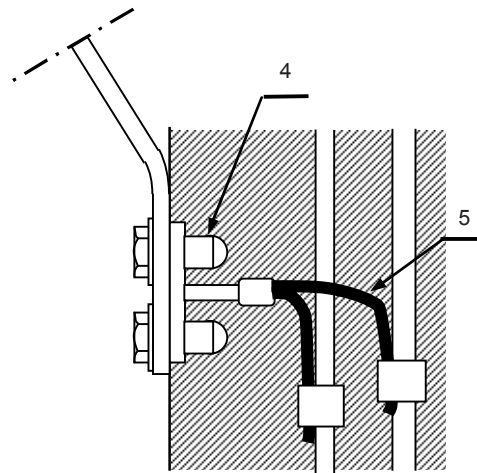

Figure E.7b

IEC 2670/10

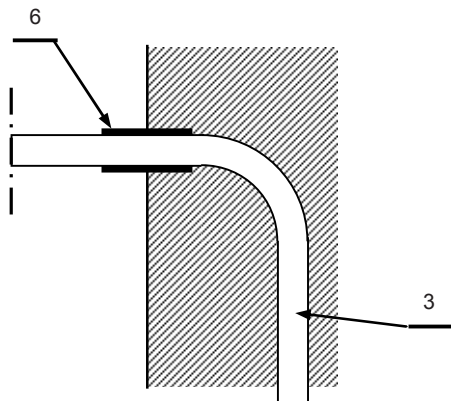

Figure E.7c

IEC 2671/10

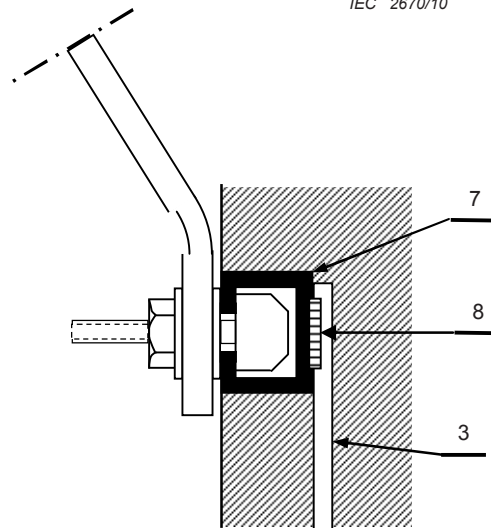

Figure E.7d

IEC 2672/10

Key

- 1 bonding conductor
- 2 nut welded to steel bonding connector
- 3 steel-bonding connector*
- 4 cast in non ferrous bonding point
- 5 stranded copper bonding connector
- 6 corrosion protection measure
- 7 C-steel (C-shaped mounting bar)
- 8 welding

* The steel-bonding connector is connected at many points by welding or clamping to the steel reinforcing bars.

NOTE Construction shown in Figure E.7c is not a generally accepted solution in terms of good engineering practice.

Figure E.7 – Examples for connection points to the reinforcement in a reinforced concrete wall

E.4.3.4 Materials

The following materials can be used as additional conductors installed in concrete for lightning protection purposes: steel, mild steel, galvanized steel, stainless steel, copper and copper coated steel .

The behaviour of a galvanized layer on steel in concrete is very complicated, particularly in concrete with chlorides, the zinc will corrode quickly on contact with the reinforcement, and can under certain conditions cause damage to the concrete. Galvanized steel should therefore not be used in coastal areas and where there may be salt in the ground water. As the use of galvanized steel in concrete requires evaluation of many external factors this material should be used only after careful analysis. With this in mind the use of the other mentioned materials is preferred over the use of galvanized steel.

In order to avoid confusion between the different types of steel rods in concrete, it is recommended that round steel rods of at least 8 mm diameter with a smooth surface be used as additional conductors in contrast to the ordinary ribbed surface of the reinforcing rods.

E.4.3.5 Corrosion

Where steel reinforcement bonding conductors are brought through a concrete wall, particular attention should be paid to protection against chemical corrosion.

The simplest corrosion protection measure is the provision of a silicon rubber or bitumen finish in the vicinity of the exit point from the wall, e.g. 50 mm or more in the wall and 50 mm or more outside the wall (see Figure E.7c). However this is generally not regarded as a good engineering solution. An improved solution is to use connectors especially developed for this purpose as shown in the other examples of Figure E.7

Where copper and copper coated steel bonding conductors are brought through the concrete wall, there is no corrosion risk if a solid conductor, proprietary bonding point, PVC covering or isolated wire is used (see Figure E.7b). For stainless steel bonding conductors, in accordance with Tables 6 and 7, no corrosion prevention measures need to be used.

In the case of extremely aggressive atmospheres, it is recommended that the bonding conductor projecting from the wall be made of stainless steel.

NOTE Galvanized steel outside the concrete in contact with reinforcement steel in the concrete may, under certain circumstances, cause damage to the concrete.

When cast-in type nuts or mild steel pieces are used, these should be protected against corrosion on the outside of the wall. Serrated lock washers should be used to make electrical contact through the protective finish of the nut (see Figure E.7a).

For more information on corrosion protection, see E.5.6.2.2.2.

E.4.3.6 Connections

Investigations show that lashed joints are not suitable for lightning-current carrying connections. There is a risk of the lashing wire exploding and damaging the concrete. However, on the basis of earlier investigations it can be assumed that at least every third wire lashing forms an electrically conductive link, so that practically all the rods of the reinforcement are electrically interconnected. Measurements carried out on reinforced concrete structures support this conclusion.

So for lightning-carrying connections welding and clamping are the preferred methods. Lashed joints as a connection are suitable for additional conductors for equipotentialization and for EMC purposes only.

Connections of external circuits to the interconnected reinforcement should be performed by means of clamps or by welding.

Welds between reinforcing bars (see Figure E.5) within concrete should be at least 50 mm long. Crossing rods should be bent to run for at least 70 mm in parallel prior to welding.

NOTE Where welding is permitted, both conventional welding and exothermic welding are acceptable.

When welded rods need to be cast into concrete, it is not sufficient to weld at crossing points with weld seam lengths of only a few millimetres. Such joints frequently break when the concrete is poured.

Figure E.5 shows correct welding of bonding conductors to the reinforcing rods of the reinforced concrete.

Where welding to the reinforcing rods is not permitted, clamps or additional dedicated conductors should be used. These additional conductors can be made of steel, mild steel, galvanized steel or copper. The additional conductors should be connected to a large number of reinforcing rods by lashings or clamps to take advantage of the shielding possibilities of the reinforcement steel.

E.4.3.7 Down-conductors

The reinforcing rods of walls or concrete columns and steel structural frames may be used as natural down-conductors. A termination joint should be provided on the roof to facilitate the connection of the air-termination system and, unless the reinforced concrete foundation is being used as the only earth-termination, termination joints should be provided to facilitate the connection with the earth-termination system.

When using a particular rod of the reinforcement steel as the down-conductor, care should be taken in the route to earth to ensure that the rod that is located in the same position will be used all the way down, thereby providing direct electrical continuity.

When the vertical continuity of the natural down-conductors, providing a straight path from roof to ground cannot be guaranteed, additional dedicated conductors should be used. These additional conductors should be lashed or clamped to the reinforcement steel.

Wherever there is doubt as to the most direct route for the down-conductor (i.e. for existing buildings) an external down-conductor system should be added.

Figures E.4 and E.8 show construction details of natural components in the LPS for reinforced concrete structures. See also E.5.4.3.2 for the use of the rods of reinforced concrete elements as foundation earth electrodes.

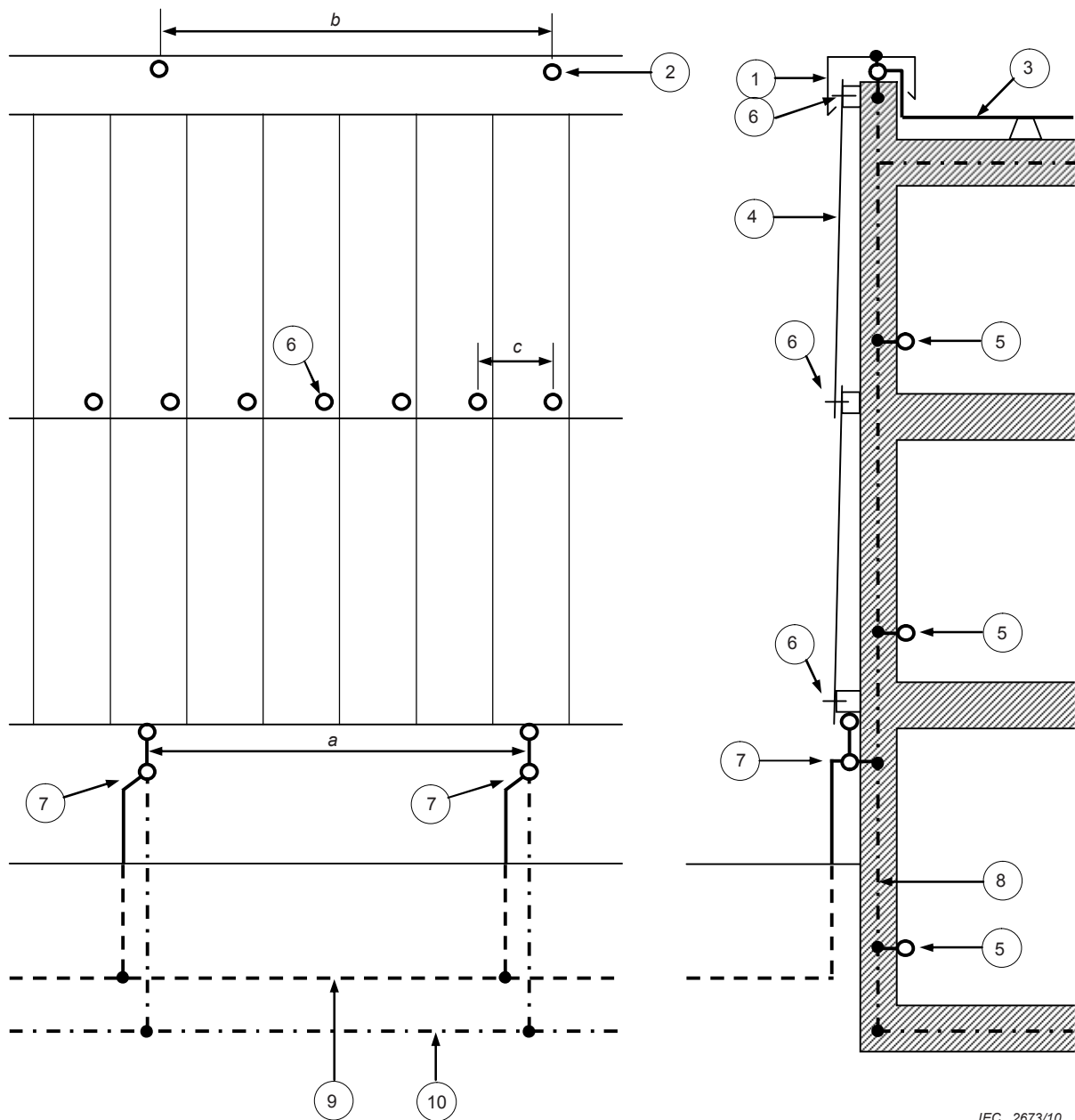

Key

- 1 metallic covering of the roof parapet
- 2 joint between facade plates and air-termination
- 3 horizontal air-termination conductor
- 4 metallic facade segment covering
- 5 equipotentialization bar of the internal LPS
- 6 joint between facade plates and to supporting frame
- 7 test joint
- 8 steel reinforcement in concrete
- 9 type B ring earth electrode
- 10 foundation earth electrode

An applicable example may utilize the following dimensions $a = 5 \text{ m}$ $b = 5 \text{ m}$ $c = 1 \text{ m}$.

NOTE For the joints between the plates, see Figure E.35.

Figure E.8a – Use of a metallic facade covering as a natural down-conductor system on a structure of steel-reinforced concrete

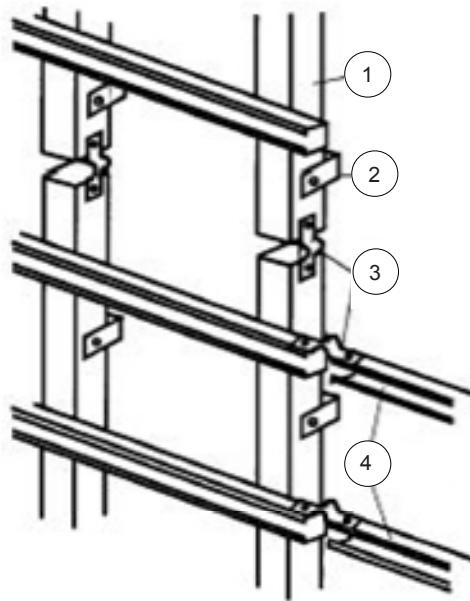

IEC 2674/10

Key

- 1 vertical frame
- 2 wall fixing
- 3 connectors
- 4 horizontal frame

Figure E.8b – Connection of facade supports

Figure E.8 – Use of metallic facade as natural down-conductor system and connection of facade supports

Internal down-conductors in the individual columns and the walls should be interconnected by means of their steel reinforcing rods and should conform to the conditions for electrical continuity according to 4.3.

Steel reinforcing rods of individual prefabricated concrete elements and the reinforcing rods of concrete columns and concrete walls should be connected to the reinforcing rods of floors and roofs before the floors and roofs are cast.

Extensive continuously conductive parts exist within the reinforcing of all constructional elements, which are cast with concrete on site, for example, walls, columns, stairs and lift shafts. If floors are constructed of site-cast concrete, the down-conductors in the individual columns and walls should be interconnected by means of their reinforcing rods to ensure an even distribution of the lightning current. If floors are constructed of prefabricated concrete elements, such connections are generally not available. However, at little extra cost it is generally possible to prepare joints and terminations to connect the reinforcing rods of the individual prefabricated concrete elements to the reinforcing rods of the columns and walls before the floors are cast by insertion of additional connecting rods.

Prefabricated concrete elements used as suspended facades are not effective for lightning protection as bonding connections are not provided. If highly effective lightning protection is to be provided for equipment installed within a structure, such as office buildings with extensive information-processing equipment and computer networks, it is necessary for the reinforcing rods of such facade elements to be interconnected and connected to the reinforcing rods of the load-bearing elements of the structure in such a manner that the lightning current can flow through the complete outer surface of the structure (see Figure E.4).

If continuous strip windows are installed in the outer walls of a structure, it is essential that a decision be taken as to whether the connection of the prefabricated concrete parts above and below the continuous strip windows should be made by means of the existing columns or whether they should be interconnected at smaller intervals corresponding to the window pitch.

Extensive integration of conductive parts of the outer walls improves the electromagnetic shielding of the interior of the structure. Figure E.9 shows the connection of continuous strip windows to a metal facade covering.

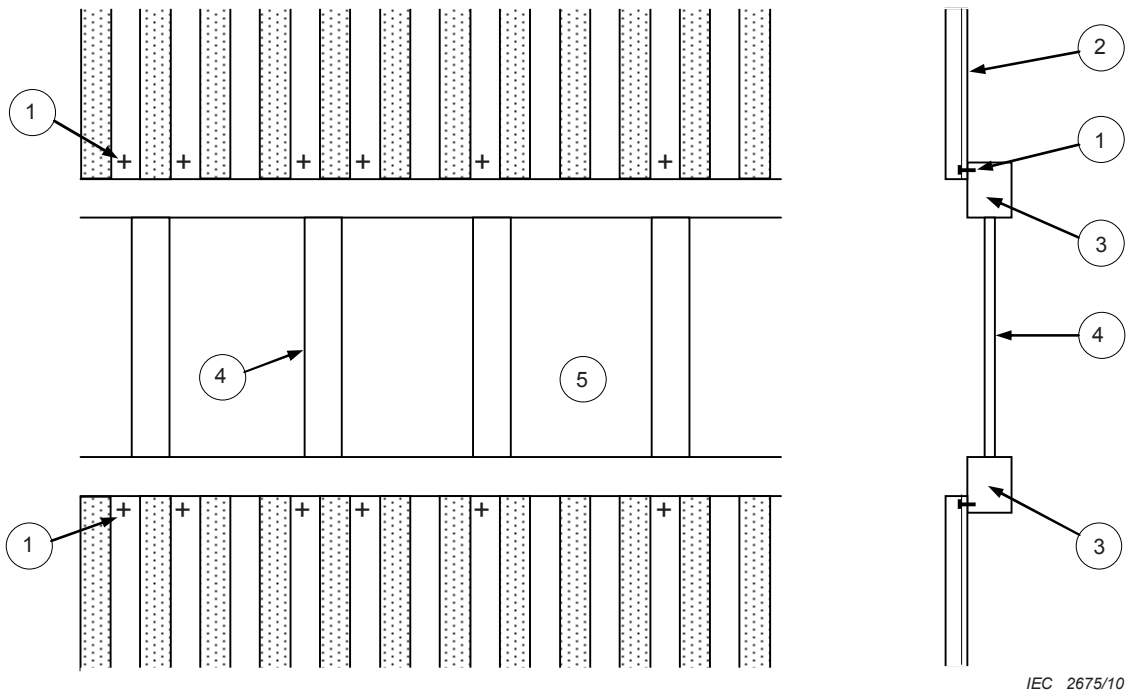

IEC 2675/10

Key

- 1 joint between a facade plate segment and the metallic strip window
- 2 metallic facade plate
- 3 horizontal metallic strip
- 4 vertical metallic strip
- 5 window

Figure E.9 – Connection of the continuous strip windows to a metal facade covering

Ⓒ If steel structures are used as down-conductors, every steel column should be connected to the steel reinforcing rods of the concrete foundation according to Figure E.7 by purposely designed bonding points complying with EN 50164 series. Ⓒ

NOTE For more information on the use of steel reinforcement of structure walls for the purpose of electromagnetic shielding, see Ⓒ EN 62305-4. Ⓒ

In the case of large, low buildings such as halls, the roof is supported not only at the building circumference but also by internal columns. Conductive columns should be connected to the air-termination system at the top and to the equipotential bonding system at the floor, creating internal down-conductors; this to prevent dangerous sparking inside the building. Increased electromagnetic interference occurs in the vicinity of such internal down-conductors.

Steel skeleton constructions generally use steel roof girders connected by means of bolted joints. Provided the bolts are tightened with the force required to achieve mechanical strength, all bolted steel parts may be considered electrically interconnected. The thin paint layer is pierced by the lightning current on initial discharge thus forming a conductive bridge.

The electrical connection may be improved by baring the seating surface of the bolt heads, bolt nuts and washers. A further improvement can be achieved by provision of a welding seam approximately 50 mm long after completion of the structural assembly.

On existing structures with extensive conductive parts in/on the outer walls, the continuity of conductive parts should be established for use as down-conductors. This technique is also recommended when high demands on the cultural aspects of architectural design have to be maintained in addition to the demands for protection against LEMP.

Interconnected equipotentialization bars should also be provided. Each equipotentialization bar should be connected to the conductive parts in the outer walls and in the floor. This may already be provided by the horizontal reinforcing bars at the ground level and each subsequent floor level.

If possible, a connection point to the steel reinforcement in the floor or in the wall should be provided. The connection should be made to at least three reinforcing rods.

E.4.3.8 Equipotentialization

When a large number of bonding connections to the reinforcement is required at different floors and a significant interest is given to achieve current paths of low inductance utilizing the reinforcing rods of the concrete walls for potential equalization and for shielding of the inner space of the structure, ring-conductors should be installed within or outside the concrete on the separate floors. These ring conductors should be interconnected by means of vertical rods at intervals not greater than 10 m.

This arrangement should be given preference due to its greater reliability, especially where the magnitude of the interference current is unknown.

A meshed-connection conductor network is also recommended. Connections should be designed to carry high currents in the event of a fault in the energy supply.

In large structures, the equipotentialization bar acts as a ring conductor. In such cases connection points to the steel-reinforcing bars should be made every 10 m. No special measures other than those prescribed for the basement in 6.2.2 a) for connection of the structure reinforcement to the LPS are necessary.

E.4.3.9 Foundation as earth-termination

For large structures and industrial plants the foundation is normally reinforced. The reinforcing rods of the foundation, foundation slab and outer walls in the region below the soil surface of such structures form an excellent foundation earth electrode, provided the requirements of 5.4 are satisfied.

The reinforcing rods of the foundation and the buried walls can be used as foundation earth electrode.

This method achieves good earthing at minimum cost. In addition, the metal enclosure, consisting of the steel reinforcement of the structure, in general offers a good potential reference for the electric power supply, telecommunication and electronic installations of the structure.

In addition to the interconnection of the reinforcing rods by wire-lashing, the installation of an additional meshed metal network to ensure good joints is recommended. This additional network should also be lashed to the reinforcement steel. The terminal conductors for connections of external down-conductors or structure elements used as down-conductors and for connection of the earth-termination installed externally should be brought out of the concrete at suitable points.

In general, the reinforcing of a foundation is electrically conductive except in cases where gaps are provided between different parts of the structure to allow different settling rates.

Gaps between conductive structure parts should be bridged by bonding conductors conforming to Table 6 using clamps and joints in accordance with 5.5.

Reinforcing rods of concrete columns and walls standing on a foundation should be connected to the reinforcing rods of the foundation and to the conductive parts of the roof.

Figure E.10 shows the design of the LPS of a reinforced concrete structure for concrete columns, walls and a roof with conductive parts.

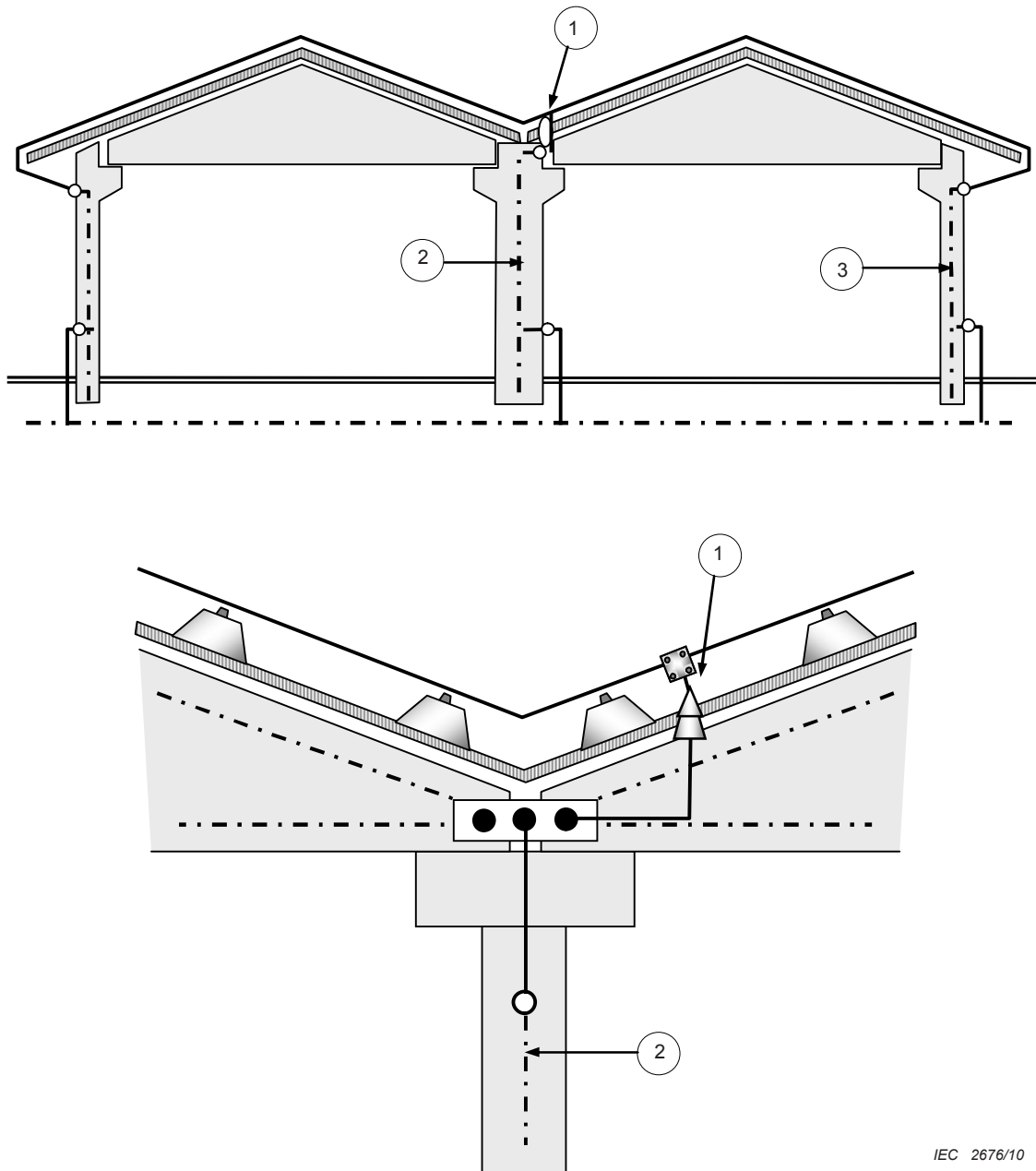

IEC 2676/10

Key

- 1 LPS conductor passing a watertight bushing
- 2 steel reinforcement in a concrete column
- 3 steel reinforcement in concrete walls

NOTE The steel reinforcing of an internal column becomes a natural internal down-conductor when the steel reinforcing of the column is connected to the air-termination and the earth-termination of the LPS. The electromagnetic environment near the column should be considered when sensitive electronic equipment is installed near the column.

Figure E.10 – Internal down-conductors in industrial structures

When welding to reinforcing is not allowed, additional conductors should be installed in the columns, or the connections should be implemented by means of tested joints. These additional conductors should be lashed or clamped to the reinforcing steel.

After completion of construction and connecting all the services to the building via an equipotential bonding bar, it will often be impossible (in practice) to measure the earthing resistance as part of the maintenance programme.

If in certain conditions it is not possible to measure the earthing resistance of the foundation earth, the installation of one or more reference earth electrodes close to the structure provide a possible method of monitoring the changes in the environment of the earthing system over the years by performing a circuit measurement between the earth electrode and the foundation earthing system. However, good equipotentialization is the main advantage of the foundation earthing system and the resistance to earth tends to be less important.

E.4.3.10 Installation procedures

All lightning protection conductors and clamps should be installed by the installer of the LPS.

Agreement should be reached with the civil works contractor in sufficient time to ensure that the time schedule for construction work is not exceeded as a result of delay in installation of the LPS before pouring the concrete.

During construction, measurements should be taken regularly and an LPS installer should supervise the construction (see 4.3).

E.4.3.11 Prefabricated reinforced concrete parts

If prefabricated reinforced concrete parts are used for lightning protection, e.g. as down-conductors for shielding or as conductors for potential equalization, connection points according to Figure E.7 should be attached to them to allow later interconnection of the prefabricated reinforcement with the reinforcement of the structure in a simple manner.

The location and form of connection points should be defined during the design of the prefabricated reinforced concrete parts.

The connection points should be located so that in the prefabricated concrete part a continuous reinforcing rod runs from one bonding joint to the next.

When the arrangement of continuous reinforcing rods in a prefabricated reinforced concrete part is not possible with standard reinforcing rods, an additional conductor should be installed and lashed to the existing reinforcement.

In general, one connection point and a bonding conductor is required at each corner of a plate-like prefabricated reinforced concrete part as illustrated in Figure E.11.

E.4.3.12 Expansion joints

When the structure comprises a number of sections with expansion joints, with allowance for settling of the structure sections, and extensive electronic equipment is to be installed in the building, bonding conductors should be provided between the reinforcement of the various structural sections across the expansion joints at intervals not exceeding one half of the distance between the down-conductors specified in Table 4.

In order to ensure low-impedance potential equalization and effective shielding of the space inside a structure, expansion joints between sections of a structure should be bridged at short intervals (between 1 m and one half of the distance between down-conductors) by flexible or sliding bonding conductors depending on the required shielding factor, as shown in Figure E.11.

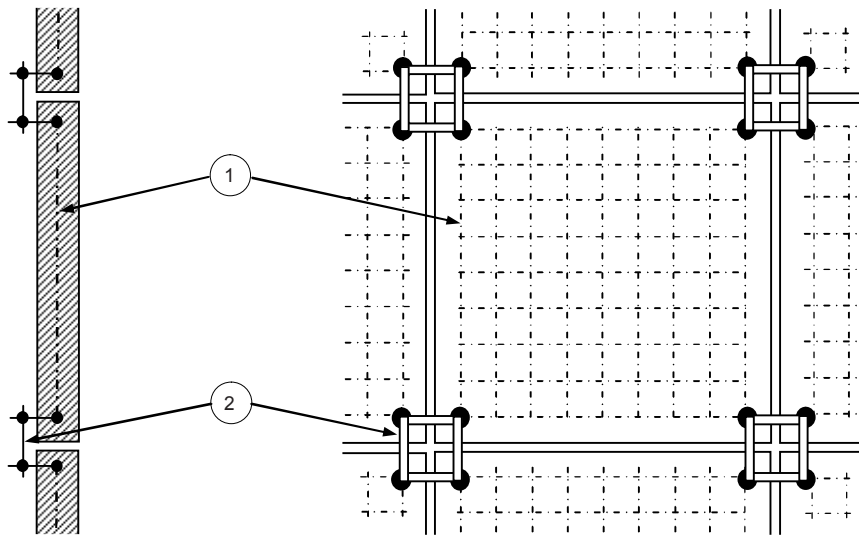

IEC 2677/10

Key

- 1 reinforced precast concrete
- 2 bonding conductors

Figure E.11a – Installation of bonding conductors on plate-like prefabricated reinforced concrete parts by means of bolted or welded conductor links

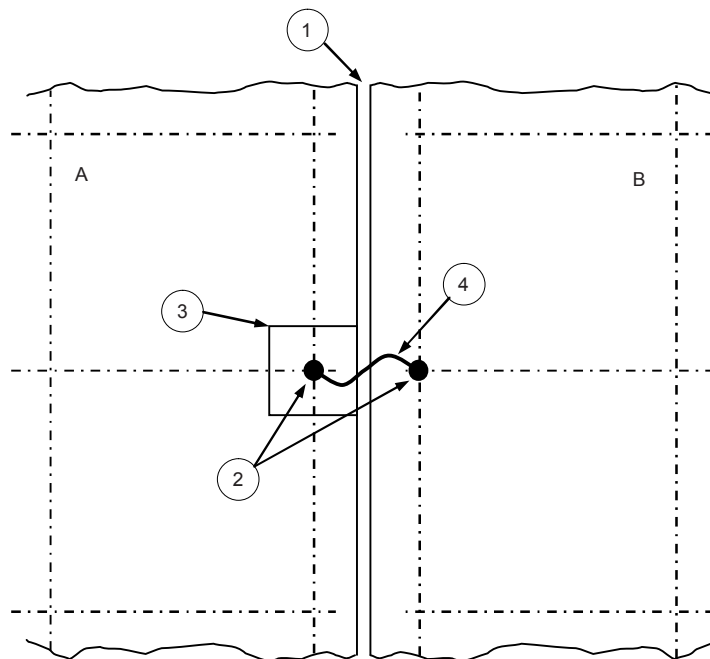

IEC 2678/10

Key

- 1 expansion slot
- 2 welded joint
- 3 recess
- 4 flexible bonding conductor
- A reinforced concrete part 1
- B reinforced concrete part 2

Figure E.11b – Construction of flexible bonds between two reinforced concrete parts bridging an expansion slot on a structure

Figure E.11 – Installation of bonding conductors in reinforced concrete structures and flexible bonds between two reinforced concrete parts

E.5 External lightning protection system

E.5.1 General

The positioning of external LPS conductors is fundamental to the design of the LPS and depends on the shape of the structure to be protected, the level of protection required and the geometric design method employed. The air-termination system design generally dictates the design of the down-conductor system, the earth-termination system and the design of the internal LPS.

If adjoining buildings have an LPS, those LPS, where permissible, should be connected to the LPS of the building under consideration.

E.5.1.1 Non-isolated LPS

In most cases, the external LPS may be attached to the structure to be protected.

When the thermal effects at the point of strike or on conductors carrying the lightning current may cause damage to the structure, or to the content of the structure to be protected, the spacing between LPS conductors and combustible material should be at least 0,1 m.

NOTE Typical cases are

- structures with combustible coverings,
- structures with combustible walls.

E.5.1.2 Isolated LPS

An isolated external LPS should be used when the flow of the lightning current into bonded internal conductive parts may cause damage to the structure or its contents.

NOTE 1 The use of an isolated LPS may be convenient where it is predicted that changes in the structure may require modifications to the LPS.

An LPS that is connected to conductive structural elements and to the equipotential bonding system only at ground level, is defined as isolated according to 3.3.

An isolated LPS is achieved either by installing air-termination rods or masts adjacent to the structure to be protected or by suspending overhead wires between the masts in accordance with the separation distance of 6.3.

An isolated LPS is also installed on structures of isolating material, such as brickwork or wood, where the separation distance, as defined in 6.3, is maintained and no connection is made to conductive parts of the structure nor to equipment installed therein, with the exception of connections to the earth-termination system at ground level.

Conductive equipment within the structure and electrical conductors should not be installed with distances to the air-termination system conductors and to the down-conductors shorter than the separation distance defined in 6.3. All future installations should conform to the requirements of an isolated LPS. These requirements should be made known to the owner of the structure by the contractor responsible for the design and construction of the LPS.

The owner should inform future contractors performing work in or on the building about these requirements. The contractor responsible for such work should inform the owner of the structure if the contractor cannot meet these requirements.

All parts of equipment installed in a structure with an isolated LPS should be placed within the protected space of the LPS and satisfy the separation distance conditions. The LPS conductors should be mounted on isolated conductor fixtures, if conductor fixings attached

directly to the structure walls are too close to conductive parts, so that the distance between the LPS and the inner conductive parts exceed the separation distance as defined in 6.3.

NOTE 2 Isolating fixtures should be equal to or longer than the separation distance, taking also into account environmental conditions.

Flush-mounted conductive roof fixtures which are not connected to the equipotential bonding and have a distance to the air-termination system not in excess of the separation distance but a distance to the equipotential bonding in excess of the separation distance, should be connected to the air-termination system of the isolated LPS. For this reason structures such as this should not be considered as isolating but as a structure with flush-mounted conductive roof fixtures which are not connected to the equipotential bonding

The design of an LPS and the safety instructions for work in the vicinity of a roof fixture should take account of the fact that the voltage on such fixtures will rise to that of the air-termination system in the event of a lightning strike.

An isolated LPS should be installed on structures with extensive interlinked conductive parts when it is desired to prevent lightning current from flowing through structure walls and internally installed equipment.

On structures consisting of continuously interlinked conductive parts such as steel construction or steel-reinforced concrete, the isolated LPS should maintain the separation distance to these conductive parts of the structure. To achieve adequate separation, LPS conductors may have to be fixed to the structure by isolation type conductor fixtures.

It should be noted, that columns and ceilings of reinforced concrete are often used in brick structures.

E.5.1.3 Dangerous sparking

Dangerous sparking between an LPS and metal, electrical and telecommunication installations can be avoided

- in an isolated LPS by isolation or separation according to 6.3,
- in a non-isolated LPS by equipotential bonding, according to 6.2, or by isolation or separation according to 6.3.

E.5.2 Air-termination systems

E.5.2.1 General

This standard does not provide any criteria for the choice of the air-termination system because it considers rods, stretched wires and meshed conductors as equivalent.

The arrangement of an air-termination system should be in accordance with the requirements of Table 2.

E.5.2.2 Positioning

For the design of the air-termination system, the following methods should be used, independently or in any combination, providing that the zones of protection afforded by different parts of the air-termination overlap and ensure that the structure is entirely protected according to 5.2:

- protection angle method;
- rolling sphere method;
- mesh method.

All three methods may be used for the design of an LPS. The choice of the method depends on a practical evaluation of its suitability and the vulnerability of the structure to be protected.

The positioning method may be selected by the LPS designer. However, the following considerations may be valid:

- the protection angle method is suitable for simple structures or for small parts of bigger structures. This method is not suitable for structures higher than the radius of the rolling sphere relevant to the selected protection level of the LPS;
- the rolling sphere method is suitable for complex shaped structures;
- the mesh method is for general purposes and it is particularly suitable for the protection of plane surfaces.

The air-termination design method and LPS design methods used for the various parts of the structure should be explicitly stated in the design documentation.

E.5.2.2.1 Protection angle method

Air-termination conductors, rods, masts and wires should be positioned so that all parts of the structure to be protected are inside the envelope surface generated by projecting points on the air-termination conductors to the reference plane, at an angle α to the vertical in all directions.

The protection angle α should conform to Table 2, with h being the height of the air-termination above the surface to be protected.

A single point generates a cone. Figures A.1 and A.2 show how the protected space is generated by the different air-termination conductors in the LPS.

According to Table 2, the protection angle α is different for different heights of air-termination above the surface to be protected (see Figures A.3 and E.12).

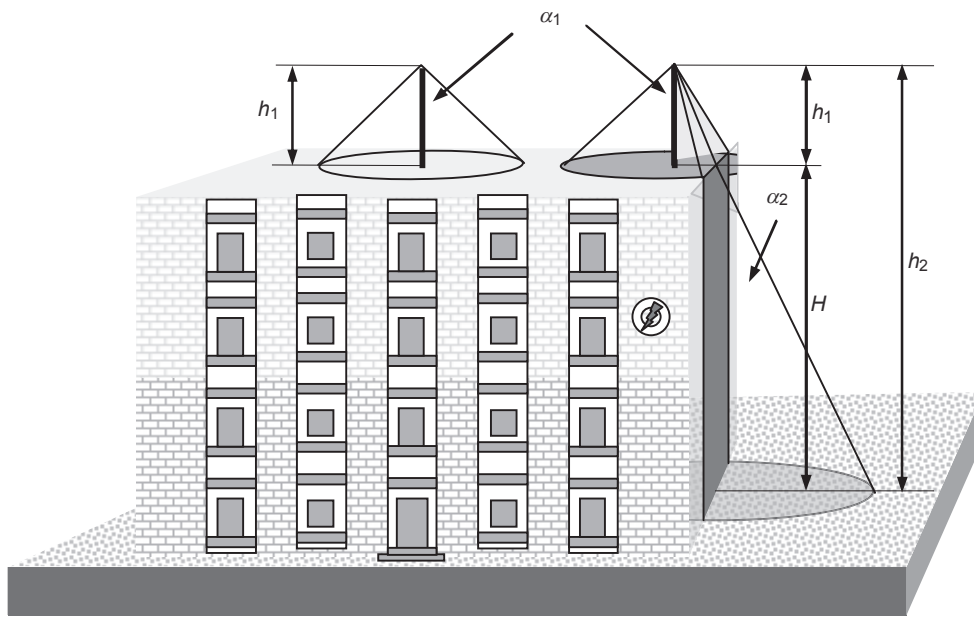

IEC 2679/10

Key

- H height of the building over the ground reference plane
- h_1 physical height of an air-termination rod
- h_2 $h_1 + H$, being the height of the air-termination rod over the ground
- α_1 the protection angle corresponding to the air-termination height $h = h_1$, being the height above the roof surface to be measured (reference plane)
- α_2 the protection angle corresponds to the height h_2

Figure E.12 – Protection angle method air-termination design for different heights according to Table 2

The protection angle method has geometrical limits and cannot be applied if H is larger than the rolling sphere radius, r , as defined in Table 2.

If structures on the roof are to be protected with finials and the protection volume of the finials is over the edge of the building, the finials should be placed between the structure and the edge. If this is not possible the rolling sphere method should be applied.

The design of air-termination using the protection angle air-termination design method is also shown in Figures E.13 and E.14 for an isolated LPS and in Figures E.15 and E.16 for a non-isolated LPS.

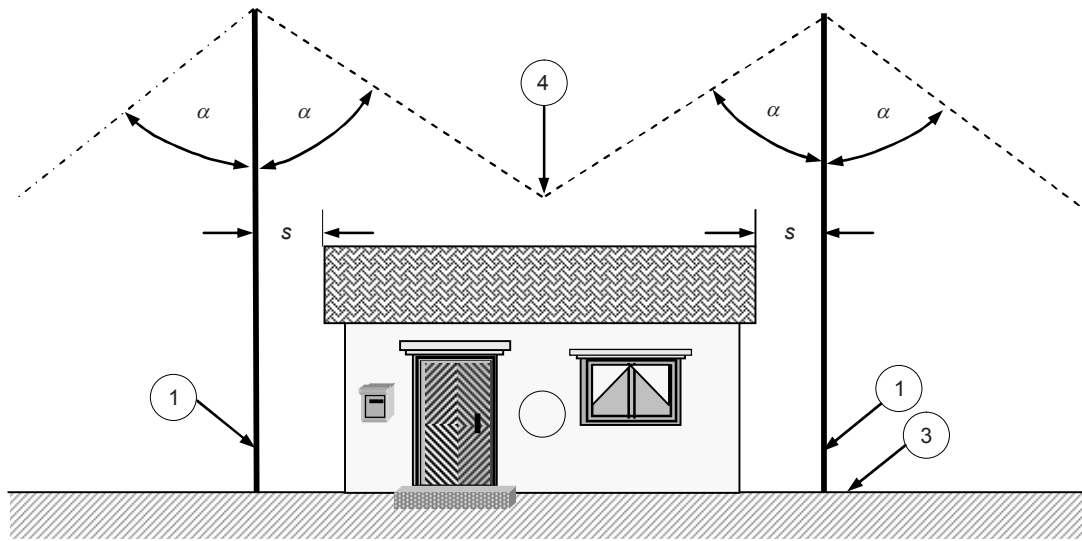

IEC 2680/10

Key

- 1 air-termination mast
- 2 protected structure
- 3 ground being the reference plane
- 4 intersection between protection cones
- s separation distance according to 6.3
- α protection angle complying with Table 2

Figure E.13a – Projection on a vertical plane

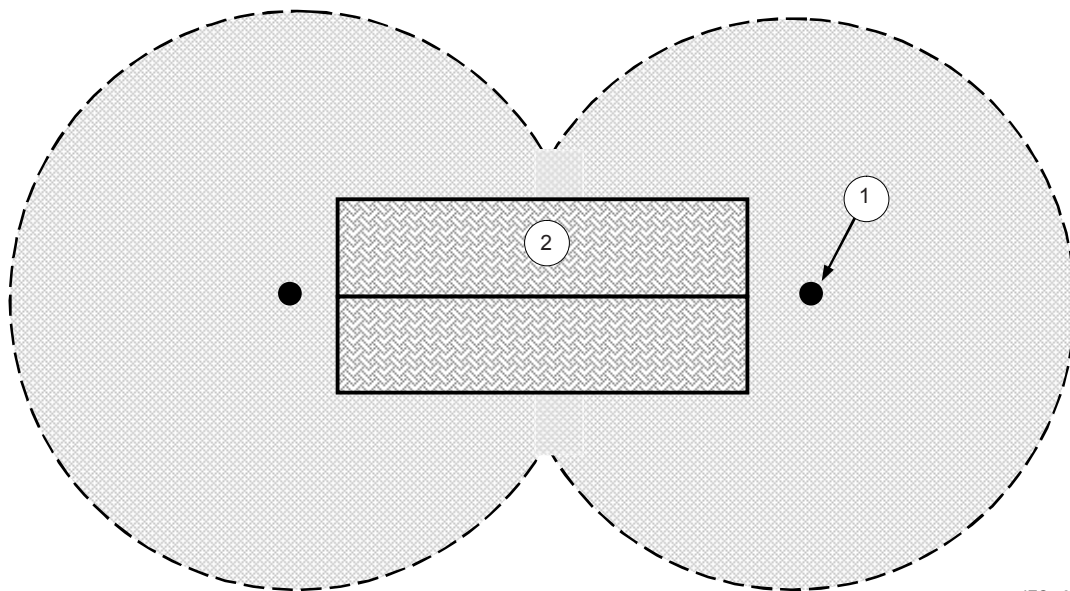

IEC 2681/10

NOTE The two circles denote the protected area on the ground as the reference plane.

Figure E.13b – Projection on the horizontal reference plane

Figure E.13 – Isolated external LPS using two isolated air-termination masts designed according to the protection angle air-termination design method

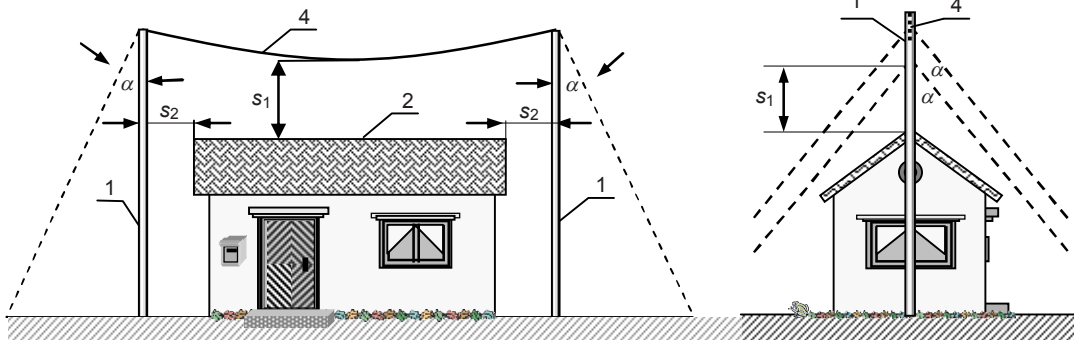

Figure E.14a – Projection on a vertical plane parallel to that containing two masts

IEC 2682/10

Figure E.14b – Projection on a vertical plane perpendicular to the plane containing the two masts

IEC 2683/10

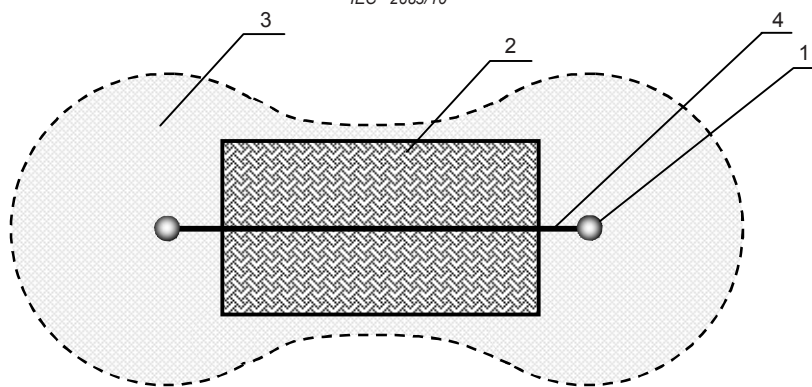

Figure E.14c – Projection on the horizontal reference plane

IEC 2684/10

Key

- 1 air-termination mast
- 2 protected structure
- 3 protected area on the reference plane
- 4 horizontal wire air-termination
- s_1, s_2 separation distances according to 6.3
- α protection angle complying with Table 2

NOTE The air-termination system is designed according to the protection angle air-termination design method. The whole structure should be inside the protected volume.

Figure E.14 – Isolated external LPS using two isolated air-termination masts, interconnected by horizontal catenary wire

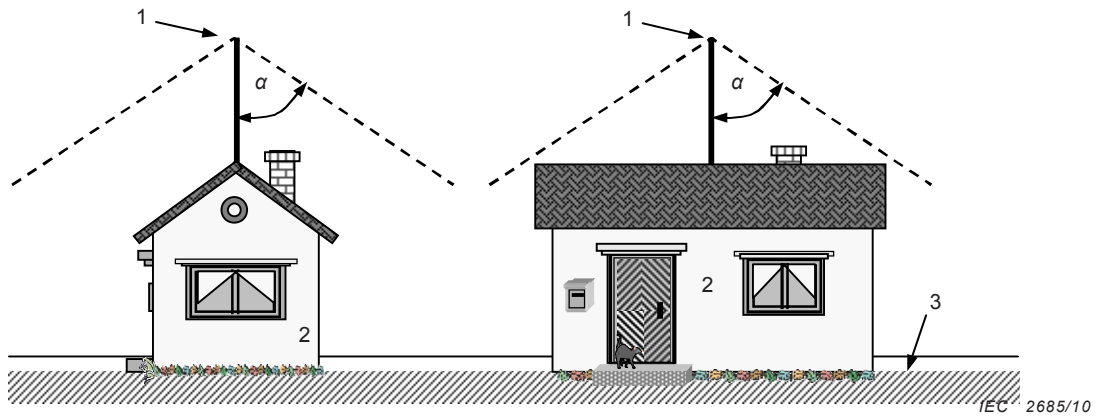

Figure E.15a – Example using one air-termination rod

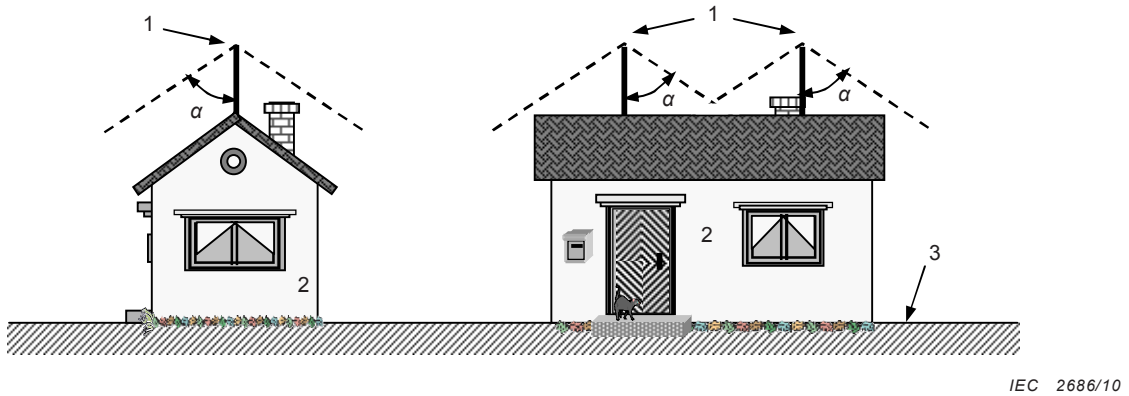

Figure E.15b – Example using two air-termination rods

Key

- 1 air-termination rod
- 2 protected structure
- 3 assumed reference plane
- α protection angle complying with Table 2

NOTE The whole structure should be inside the protected volumes of the air-termination rods.

Figure E.15 – Example of design of an air-termination of a non-isolated LPS by air-termination rods

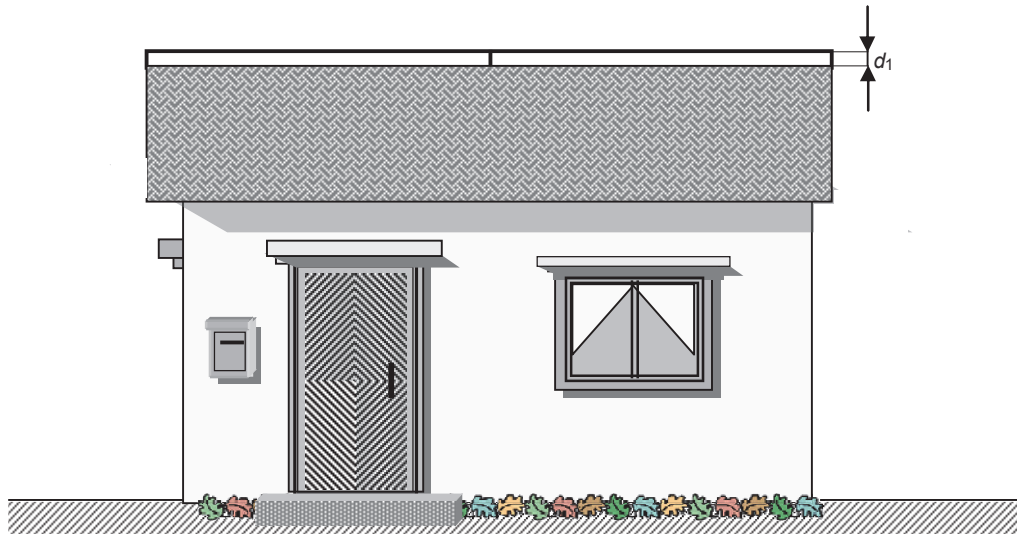

IEC 2687/10

Figure E.16a – Projection on a vertical plane containing the conductor

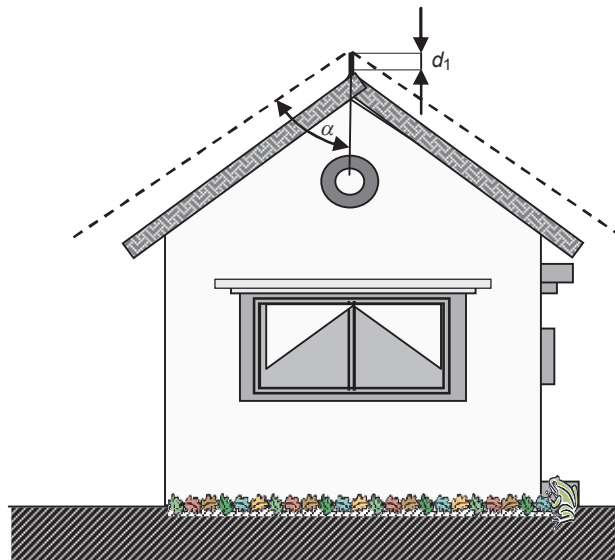

IEC 2688/10

Figure E.16b – Projection on the vertical plane perpendicular to the plane containing the conductor

Key

- α protection angle complying with Table 2
- d_1 distance of horizontal wire from the roof

NOTE The whole structure should be inside the protected volume.

Figure E.16 – Example of design of an air-termination of a non isolated LPS by a horizontal wire according to the protection angle air-termination design method

If the surface on which the air-termination system is placed is inclined, the axis of the cone which forms the protected zone is not necessarily the air-termination rod, but is instead the perpendicular to the surface on which the air-termination rod is placed; with the top of the cone being equal to the top of the air-termination rod (see Figure E.17).

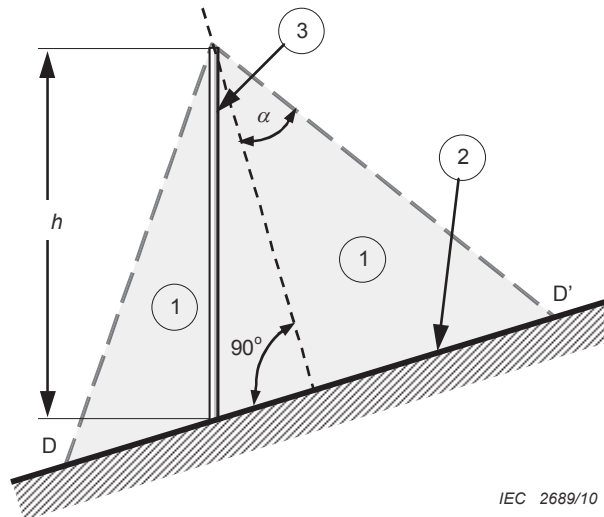

Key

- 1 protected volume
- 2 reference plane
- 3 air-termination rod
- h relevant heights of air-termination according to Table 2
- α protection angle
- D, D' limit of the protected area

Figure E.17 – Protected volume of an air-termination rod on a sloped surface using the protection angle design method

E.5.2.2.2 Rolling sphere method

The rolling sphere method should be used to identify the protected space of parts and areas of a structure when Table 2 excludes the use of the protection angle method.

Applying this method, the positioning of an air-termination system is adequate if no point of the volume to be protected is in contact with a sphere of radius, r , rolling on the ground, around and on top of the structure in all possible directions. Therefore, the sphere should touch only the ground and/or the air-termination system.

The radius r of the rolling sphere depends on the class of LPS (see Table 2). The radius of the rolling sphere is correlated with the peak value of the current in the lightning that strikes the structure: $r = 10I^{0,65}$ where I is defined as kA.

Figure E.18 shows the application of the rolling sphere method to different structures. The sphere of radius r is rolled around and over all the structure until it meets the ground plane or any permanent structure or object in contact with the ground plane which is capable of acting as a conductor of lightning. A striking point could occur where the rolling sphere touches the structure and at such points protection by an air-termination conductor is required.

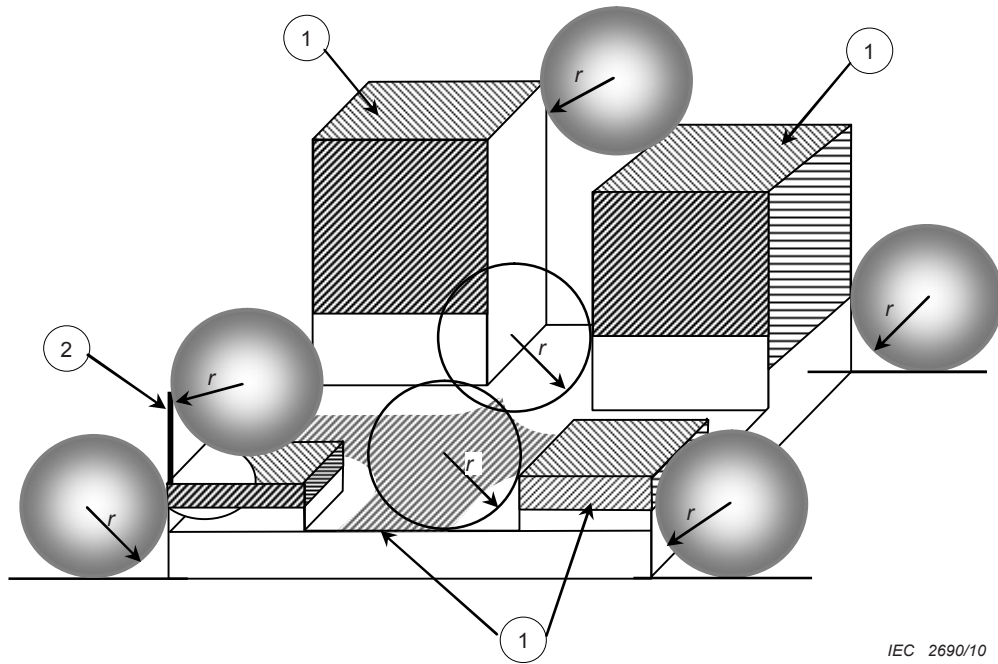

IEC 2690/10

Key

- 1 shaded areas are exposed to lightning interception and need protection according to Table 2
- 2 mast on the structure
- r radius of rolling sphere according to Table 2

NOTE Protection against side flashes is required according to 5.2.3 and A.2.

Figure E.18 – Design of an LPS air-termination conductor network on a structure with complicated shape

When the rolling sphere method is applied to drawings of the structure, the structure should be considered from all directions to ensure that no part protrudes into an unprotected zone – a point which might be overlooked if only front, side and plan views on drawings are considered.

The protected space generated by an LPS conductor is the volume not penetrated by the rolling sphere when it is in contact with the conductor and applied to the structure.

Figure E.19 shows the protection afforded by an LPS air-termination system according to the mesh method, rolling sphere method and protection angle method with a general arrangement of air-termination elements.

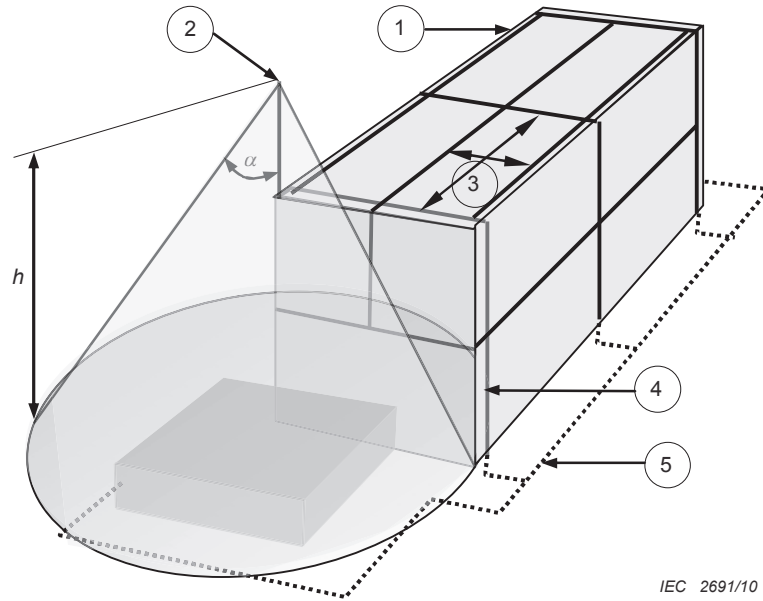

IEC 2691/10

Key

- 1 air-termination conductor
- 2 air-termination rod
- 3 mesh size
- 4 down-conductor
- 5 earthing system with ring conductor
- h* height of the air-terminal above ground level
- α protection angle

Figure E.19 – Design of an LPS air-termination according to the protection angle method, mesh method and general arrangement of air-termination elements

In the case of two parallel horizontal LPS air-termination conductors placed above the horizontal reference plane in Figure E.20, the penetration distance p of the rolling sphere below the level of the conductors in the space between the conductors may be calculated:

$$p = r - [r^2 - (d / 2)^2]^{1/2} \quad (\text{E.2})$$

The penetration distance p should be less than h_t minus the height of objects to be protected (the motor in Figure E.20).

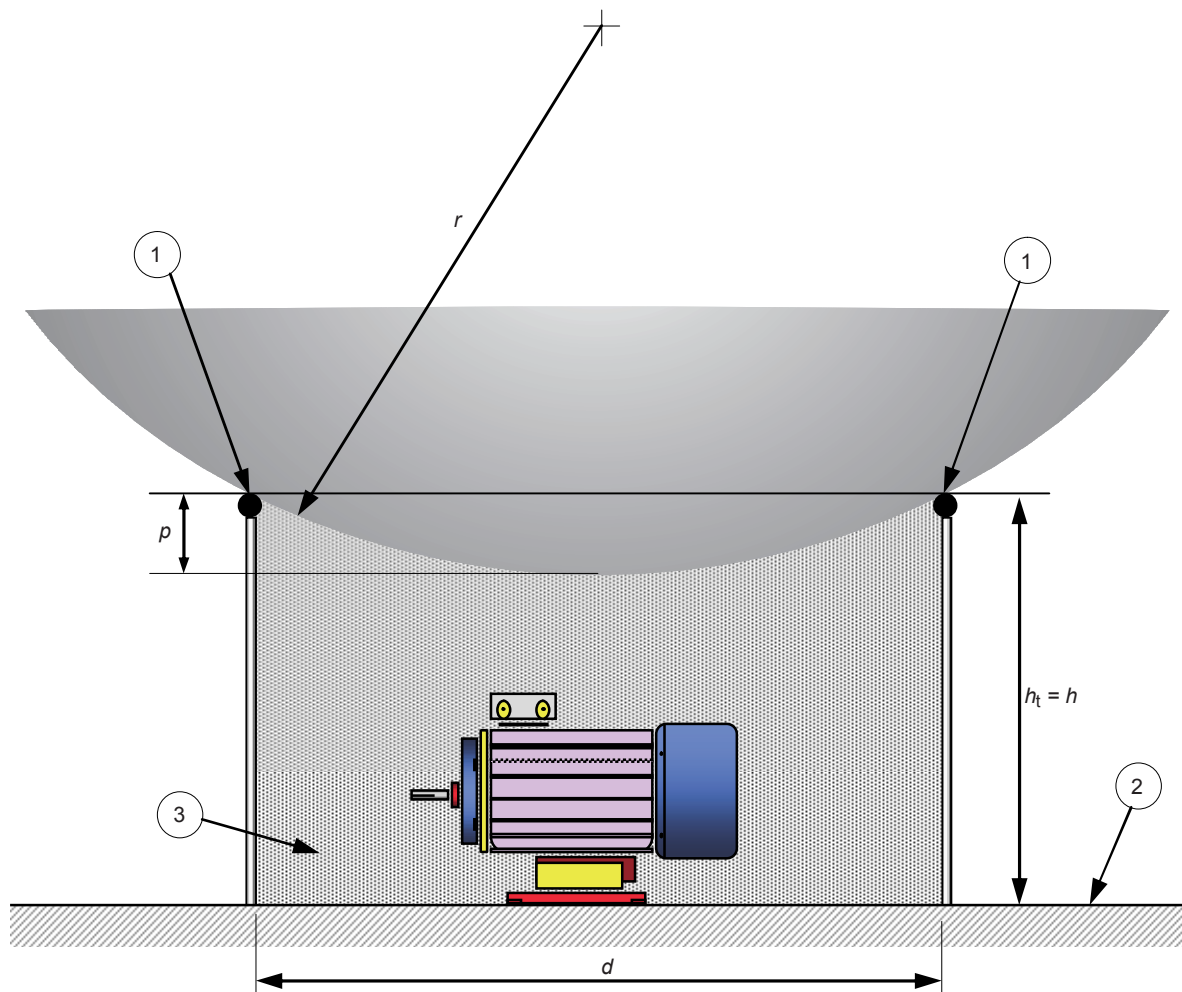

IEC 2692/10

Key

- 1 horizontal wires
- 2 reference plane
- 3 space protected by two parallel air-termination horizontal wires or two air-termination rods
- h_t physical height of the air-termination rods above the reference plane
- p penetration distance of the rolling sphere
- h height of the air-termination according to Table 2
- r radius of the rolling sphere
- d distance separating two parallel air-terminal horizontal wires or two air-terminal rods

NOTE The penetration distance p of the rolling sphere should be less than h_t minus the largest height of objects to be protected, in order to protect objects in the space between the terminations.

Figure E.20 – Space protected by two parallel air-termination horizontal wires or two air-termination rods ($r > h_t$)

The example shown in Figure E.20 is also valid for three or four air-termination rods; for example, four vertical rods placed at the corners of a square with the same applied height h . In this case, d in Figure E.20 corresponds to the diagonals of the square formed by the four rods.

The points at which lightning will strike can be determined using the rolling sphere method. The rolling sphere method can also identify the probability of occurrence of a strike to each point of the building.

Mesh method

For the purpose of protecting flat surfaces, a mesh is considered to protect the whole surface if the following conditions are fulfilled.

- a) As mentioned in Annex A, air-termination conductors are positioned on
 - roof edge lines,
 - roof overhangs,
 - roof ridge lines, if the roof slope exceeds 1/10,
 - the lateral surfaces of the structure higher than 60 m at levels higher than 80 % of the height of the structure;
- b) the mesh dimensions of the air-termination network are not greater than the values given in Table 2;
- c) the network of the air-termination system is accomplished in such a way that the lightning current will always encounter at least two distinct metallic routes to the earth and no metal installation protrudes outside the volume protected by air-termination systems;

NOTE A larger number of down-conductors results in reduction of the separation distance and reduces the electromagnetic field within the building (see 5.3).

- d) the air-termination conductors follow as far as possible short and direct routes.

Examples of non-isolated LPS using the air-termination mesh method design are shown in Figure E.21a for a flat-roof structure and in Figure E.21b for a sloped-roof structure. Figure E.21c shows an example of an LPS on a industrial building.

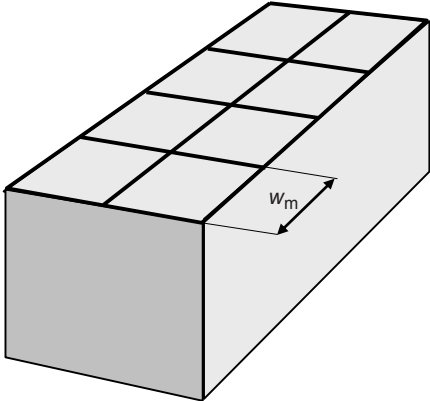

IEC 2693/10

Figure E.21a – LPS air-termination on a flat-roof structure

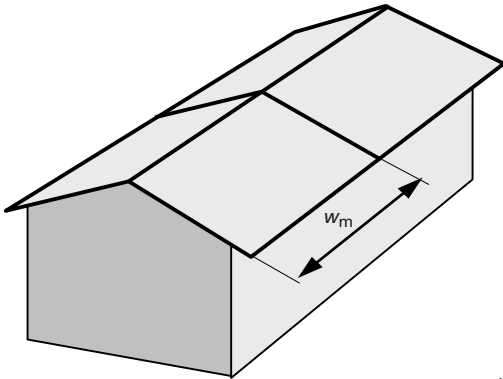

IEC 2694/10

Key

w_m mesh size

NOTE The mesh size should comply with Table 2.

Figure E.21b – LPS air-termination on a sloped-roof structure

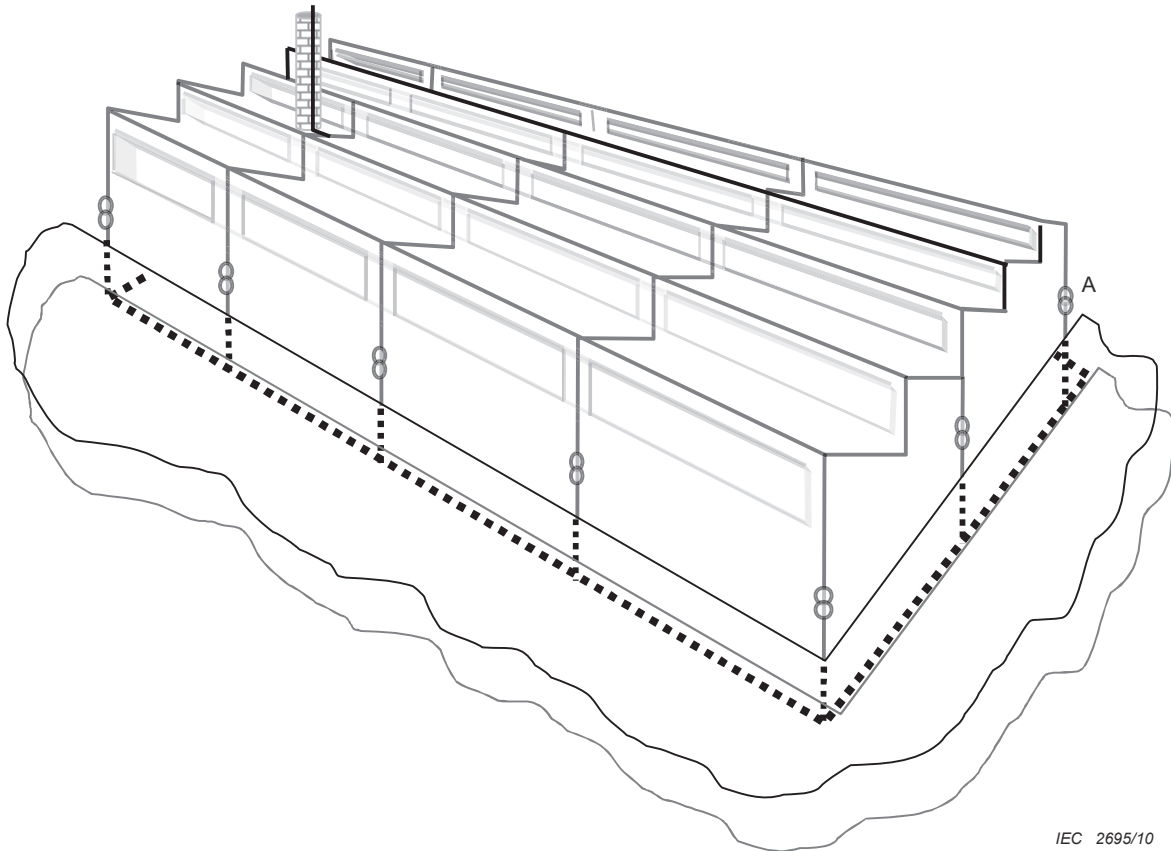

Key

A test joint

NOTE All dimensions should comply with the selected protection level according to Tables 1 and 2.

Figure E.21c –LPS on a shed roof structure

Figure E.21 – Three examples of design of non-isolated LPS air-termination according to the mesh method air-termination design

E.5.2.3 Air-terminations against flashes to the side on tall structures

In structures higher than 60 m, the topmost 20 % of lateral surfaces should be equipped with air terminals. For the part of this surface to be protected which is below 60 m the protection can be omitted.

NOTE 1 For structures between 60 m and 75 m in height, the area protected need not extend below 60 m.

NOTE 2 If sensitive parts (e.g. electronic equipment) are present on the outside of the wall in the upper part of the building, they should be protected by special air-termination measures, such as horizontal finials, mesh conductors or equivalent.

E.5.2.4 Construction

E.5.2.4.1 General information

Ⓒ The maximum permissible temperature for a conductor will not be exceeded if its cross-section complies with Table 6 and the EN 50164 series. Ⓒ

A roof or wall constructed from combustible material should be protected from the dangerous effect of lightning current heating the LPS conductors by using one or more of the following measures:

- reducing the temperature of the conductors by increasing the cross-section;

- increasing the distance between the conductors and the roof covering (see also 5.2.4);
- inserting a heat-protective layer between the conductors and the flammable material.

NOTE Research has shown that it is advantageous for air-termination rods to have a blunt tip.

E.5.2.4.2 Non-isolated air-termination

Air-termination conductors and down-conductors should be interconnected by means of conductors at the roof level to provide sufficient current distribution over the down-conductors.

Conductors on roofs and the connections of air-termination rods may be fixed to the roof using both conductive or non-conductive spacers and fixtures. The conductors may also be positioned on the surface of a wall if the wall is made of non-combustible material.

NOTE For more details see EN 50164 series.

Recommended fixing centres for these conductors are shown in Table E.1.

Table E.1 – Suggested fixing centres

Arrangement	Fixing centres for tape, stranded and soft drawn round conductors mm	Fixing centres for round solid conductors mm
Horizontal conductors on horizontal surfaces	1 000	1 000
Horizontal conductors on vertical surfaces	500	1 000
Vertical conductors from the ground to 20 m	1 000	1 000
Vertical conductors from 20 m and thereafter	500	1 000
NOTE 1 This table does not apply to built-in type fixings, which may require special considerations.		
NOTE 2 Assessment of environmental conditions (i.e. expected wind load) should be undertaken and fixing centres different from those recommended may be found to be necessary.		

On small houses and similar structures with a roof ridge, a roof conductor should be installed on the roof ridge. If the structure is completely within the protected area provided by the roof-ridge conductor, at least two down-conductors should be routed over the gable edges at opposite corners of the structure.

The gutters at the edge of the roof may be used as natural conductors provided that they conform to 5.2.5.

Figures E.22a, E.22b and E.22c depict an example of the arrangement of the conductors on a roof and down-conductors for a sloped roof structure.

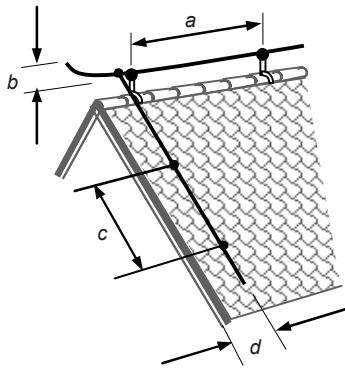

IEC 2696/10

Figure E.22a – Installation of air-termination conductor on the ridge of a sloped roof and a roof down-conductor

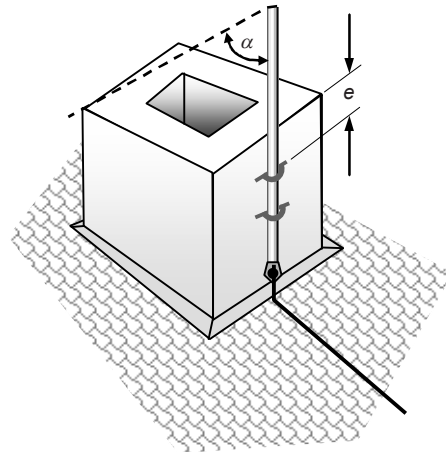

IEC 2697/10

Figure E.22b – Installation of air-termination rod for protection of chimney using the protection angle air-termination design method

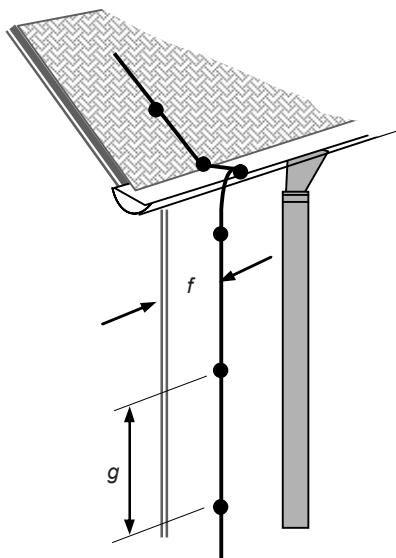

IEC 2698/10

Figure E.22c – Installation of a down-conductor with connection to the gutter

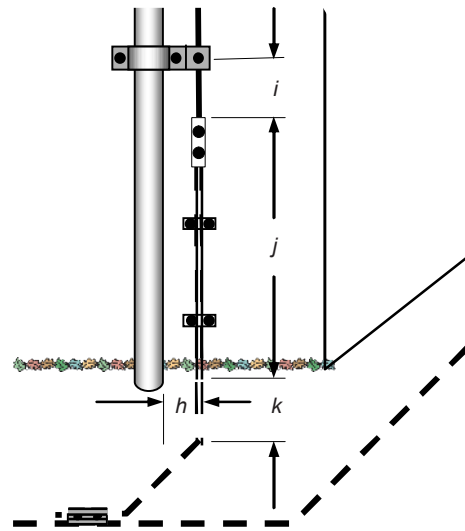

IEC 2699/10

Figure E.22d – Installation of a test joint in a down-conductor and bonding to a drain-pipe

Examples of suitable dimensions:

- a 1 m
- b 0,15 m (not mandatory)
- c 1 m
- d as close to the edge as possible
- e 0,2 m
- f 0,3 m
- g 1 m
- h 0,05 m
- i 0,3 m
- j 1,5 m
- k 0,5 m
- α protection angle according to Table 2

Figure E.22 – Four examples of details of an LPS on a structure with sloped tiled roofs

Figure E.23 shows an example of an LPS with concealed conductors.

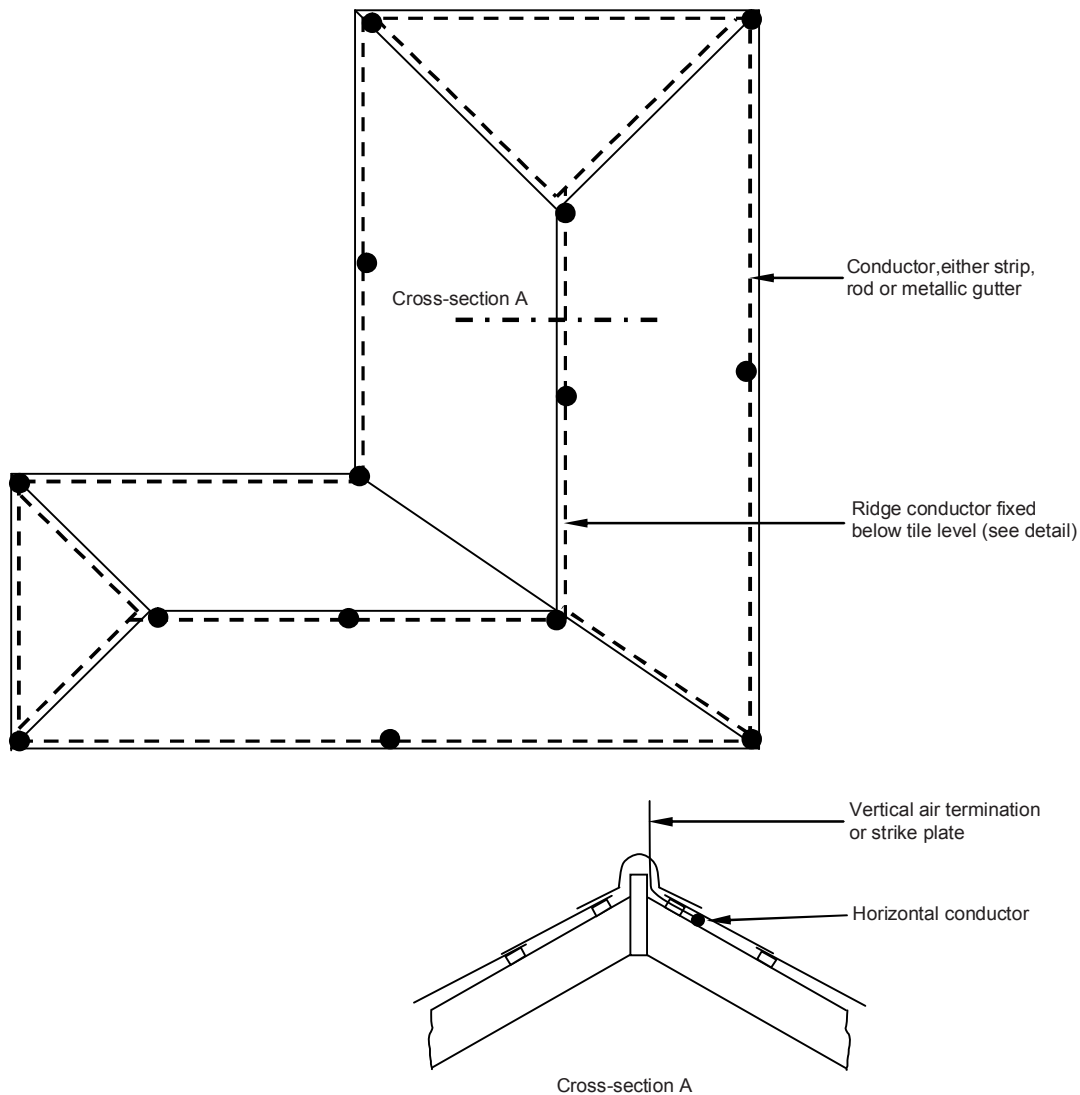

IEC 2700/10

Key

- Concealed conductor
- Vertical air termination (0,3 m high bare vertical rod) at short (<10 m) intervals or strike plates at <5m intervals

Figure E.23 – Air-termination and visually concealed conductors for buildings less than 20 m high, with sloping roofs

In the case of long structures, additional conductors in accordance with Table 4 should be connected to the air-termination conductors mounted on the roof ridge.

On buildings with large roof overhangs, the roof-ridge conductor should be extended to the end of the ridge. On the gable edge of the roof a conductor should be connected from the roof-ridge conductor to the down-conductor.

As far as is practicable, air-termination conductors, connecting conductors and down-conductors should be installed in a straight route. On non-conducting roofs, the conductor may be placed either under, or preferably over, the roof tiles. Although mounting it under the

tiles has the advantage of simplicity and less risk of corrosion, it is better, where adequate fixing methods are available, to install it along the top of the tiles (i.e. externally) so reducing the risk of damage to the tiles should the conductor receive a direct flash. Installing the conductor above the tiles also simplifies inspection. Conductors placed below the tiles should preferably be provided with short vertical finials which protrude above roof level and are spaced not more than 10 m apart. Appropriate exposed metal plates may also be used (see Figure E.23) provided they are spaced not more than 5 m apart.

On structures with flat roofs, the perimeter conductors should be installed as close to the outer edges of the roof as practicable.

When the roof surface exceeds the mesh size stipulated in Table 2, additional air-termination conductors should be installed.

Figures E.22a, E.22b and E.22c show examples of the construction details of fixtures for air-termination conductors on the sloped roof of a structure. Figure E.24 provides an example of construction details for fixtures on a flat roof.

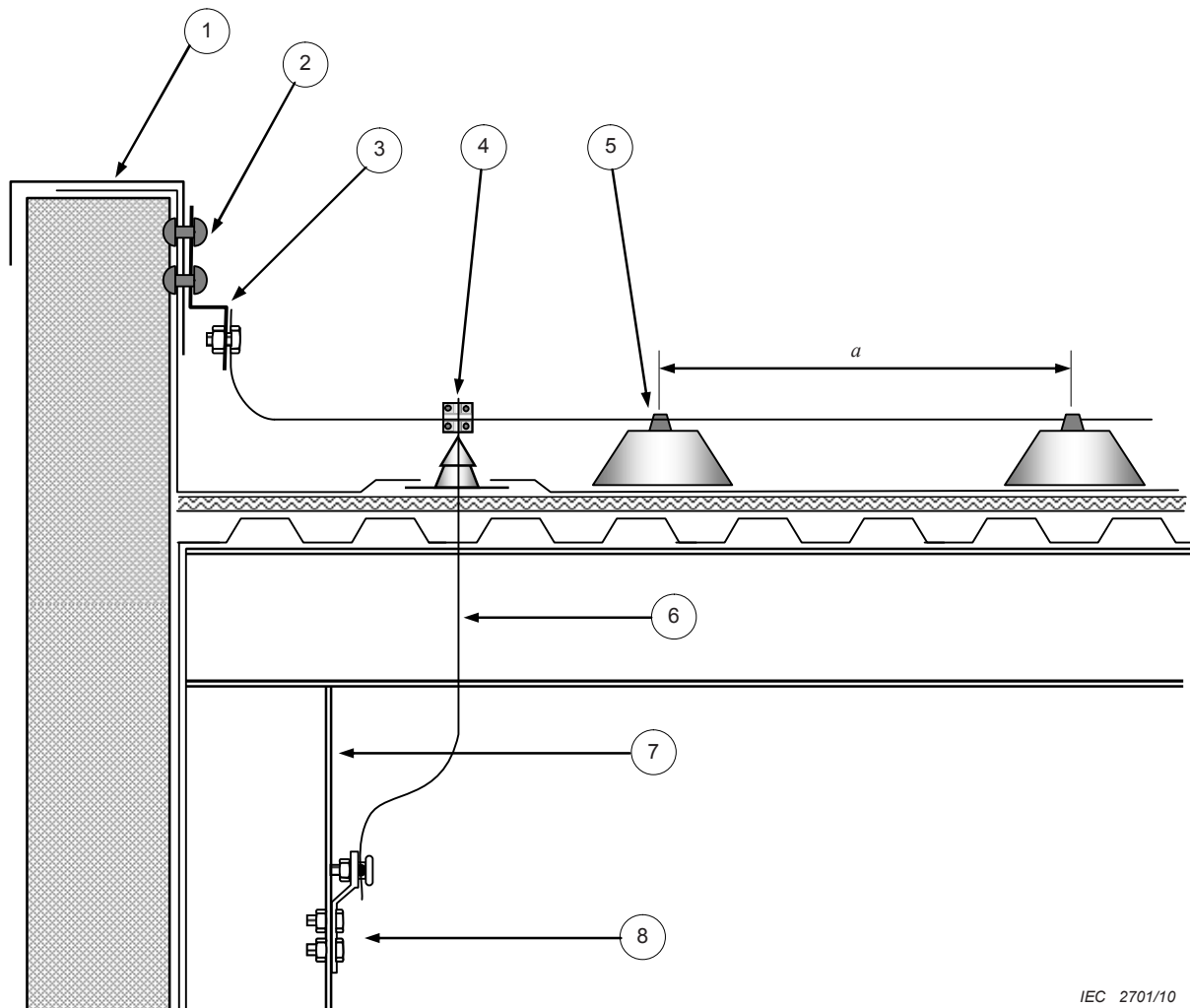

IEC 2701/10

Key

- a 500 mm to 1 000 mm, see Table E.1
- 1 roof parapet
- 2 joint
- 3 flexible conductor
- 4 T-joints
- 5 air-termination conductor fixture
- 6 LPS passing through a watertight bushing
- 7 steel girder
- 8 joint

NOTE Metallic covering on the roof parapet is used as an air-termination conductor and is connected to the steel girder used as a natural down-conductor of the LPS.

Figure E.24 – Construction of an LPS using natural components on the roof of the structure

Figure E.25 shows the positioning of the external LPS on a structure with a flat roof made of isolating material such as wood or bricks. The roof fixtures are within the space to be protected. On high structures, a ring connected to all down-conductors is installed on the facade. The distances between these ring conductors should comply with 5.3.1. Ring conductors below the level of the rolling sphere radius are needed as equipotentialization conductors.

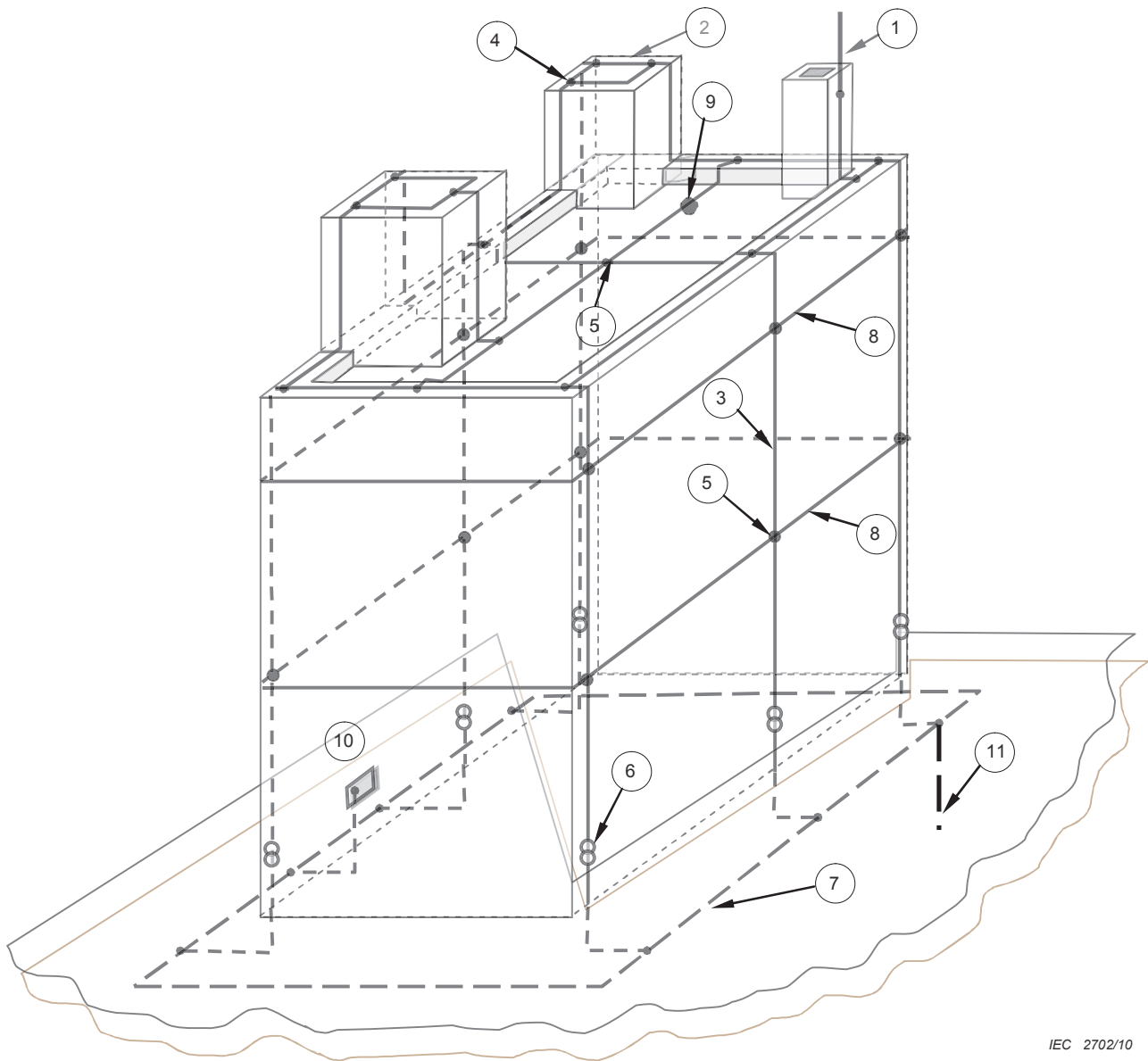

IEC 2702/10

Key

- 1 air-termination rod
- 2 horizontal air-termination conductor
- 3 down-conductor
- 4 T-type joint
- 5 cross-type joint
- 6 TEST joint
- 7 B-type earthing arrangement, ring earth electrode
- 8 equipotentialization ring conductor
- 9 flat roof with roof fixture
- 10 terminal for connecting the equipotentialization bar of the internal LPS
- 11 vertical earth rod

NOTE An equipotentialization ring is applied. The distance between the down-conductors complies with the requirements in Table 4.

Figure E.25 – Positioning of the external LPS on a structure made of isolating material e.g. wood or bricks with a height up to 60 m with flat roof and with roof fixtures

LPS conductors and rods should be mechanically secured so that they are capable of withstanding stress due to wind or weather and work carried out on the roof surface.

Metal covering provided for mechanical protection of outer walls parapet capping may be used as a natural component of the air-termination, according to 5.2.5, if there is no risk of fire ignition by melting metal. The combustibility depends on the type of material under the metal cladding. The combustibility of the material employed should be confirmed by the contractor.

The roof sealing arrangement on metallic roofs, as with other types of roof, can be perforated by a lightning flash. In such a case, water can penetrate and leak through the roof at a point far from the striking point. If this possibility is to be avoided, an air-termination system should be installed.

Light cupolas and smoke and heat outlet flaps are normally closed. The design for the protection of such flaps should be discussed with the purchaser/owner of the building to decide whether protection should be applicable for the flaps in the open, closed and all intermediate positions.

Roof coverings of conductive sheet which do not conform to 5.2.5 may be used as air-terminations where melting at the striking point of lightning can be accepted. If this is not acceptable, the conductive roof sheeting should be protected by an air-termination system of sufficient height (see Figure E.20 and Figure E.26).

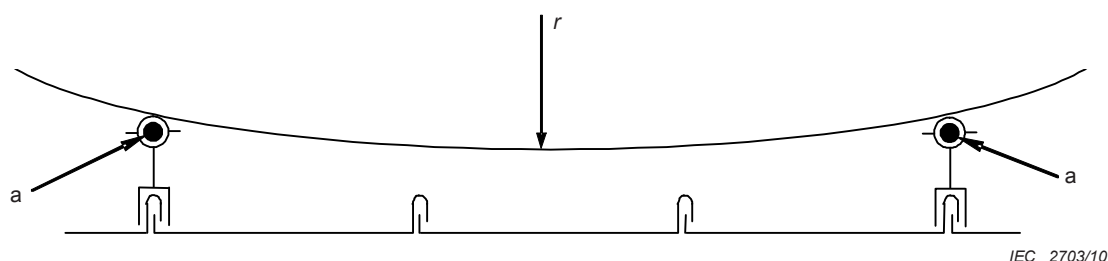

Key

- r radius of the rolling sphere, Table 2
- a air-termination conductors

NOTE The rolling sphere should not touch any part of the metallic roof including the standing seams.

Figure E.26 – Construction of air-termination network on a roof with conductive covering where puncturing of the covering is not acceptable

Non-conductive as well as conductive supports are allowed.

When conductive supports are used, the connection to the roof-sheet should withstand partial lightning current (see Figure E.26).

Figure E.24 shows an example of natural air-termination using a roof parapet as the air-termination conductor at the edge of the roof area.

Flush-mounted and protruding structures on the roof surface should be protected by means of air-termination rods. Alternatively, extraneous metalwork should be bonded to the LPS unless it conforms to 5.2.5.

Figure E.27 gives an example of the connection of the air-termination with the natural down-conductors in concrete.

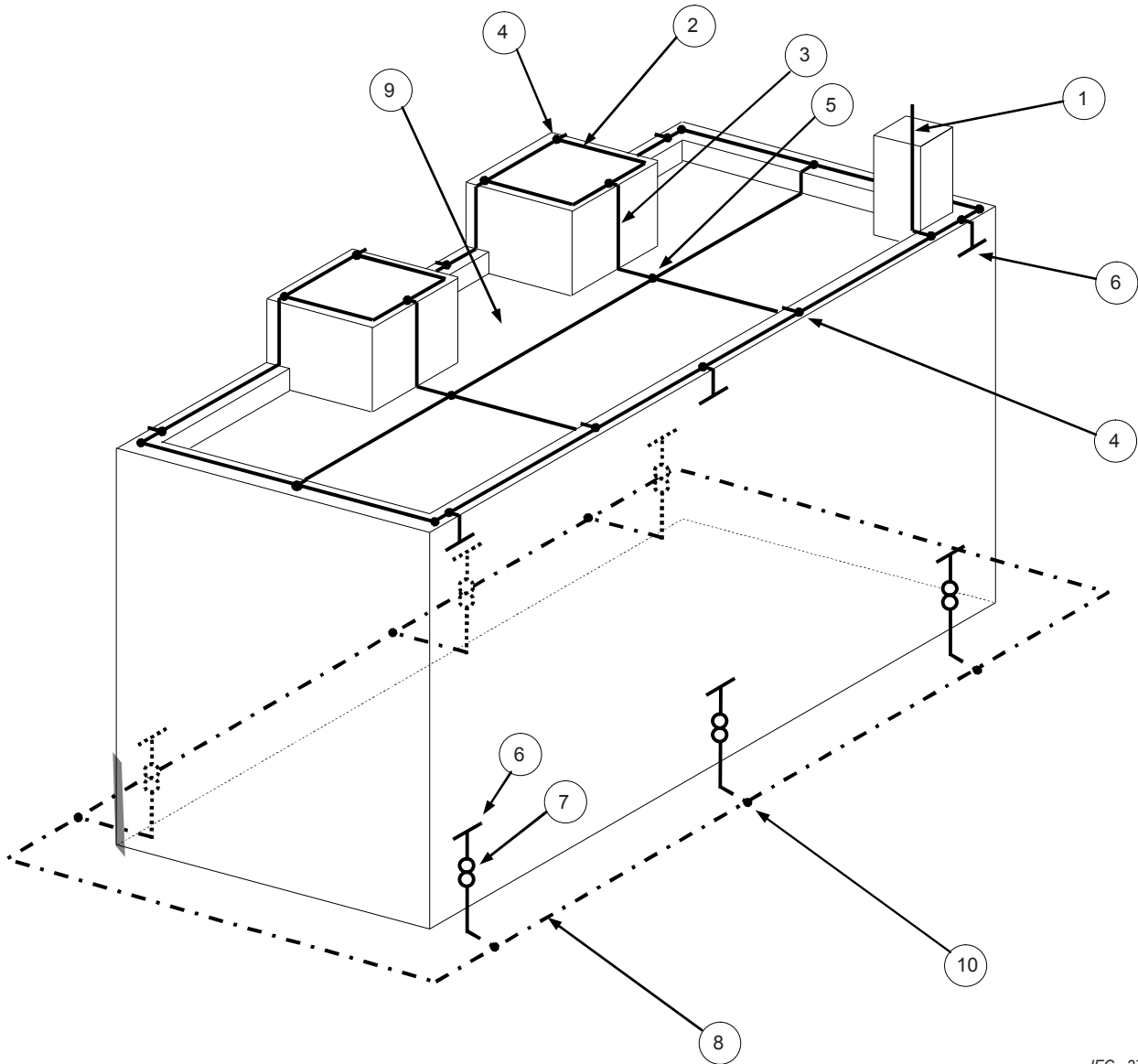

IEC 2704/10

Key

- 1 air-termination rod
- 2 horizontal air-termination conductor
- 3 down-conductor
- 4 T-type joint
- 5 cross type joint
- 6 connection to steel reinforcing rods (see E.4.3.3 and E.4.3.6)
- 7 test joint
- 8 type B earthing arrangement, ring earth electrode
- 9 flat roof with roof fixtures
- 10 T-type joint – corrosion resistant

NOTE The steel reinforcement of the structure should comply with 4.3. All dimensions of the LPS should comply with the selected protection level.

Figure E.27 – Construction of external LPS on a structure of steel-reinforced concrete using the reinforcement of the outer walls as natural components

E.5.2.4.2.1 Lightning protection for multi-storey car park roofs

For the protection of this type of structure, air-termination studs may be used. These studs can be connected to the reinforcement steel of a concrete roof (see Figure E.28). In the case of roofs where a connection to the reinforcement cannot be made, the roof conductors can be laid in the seams of the carriageway slabs and air-termination studs can be located at the mesh joints. The mesh width shall not exceed the value corresponding to the protection class given in Table 2. In this case, the persons and vehicles on this parking area are not protected against lightning.

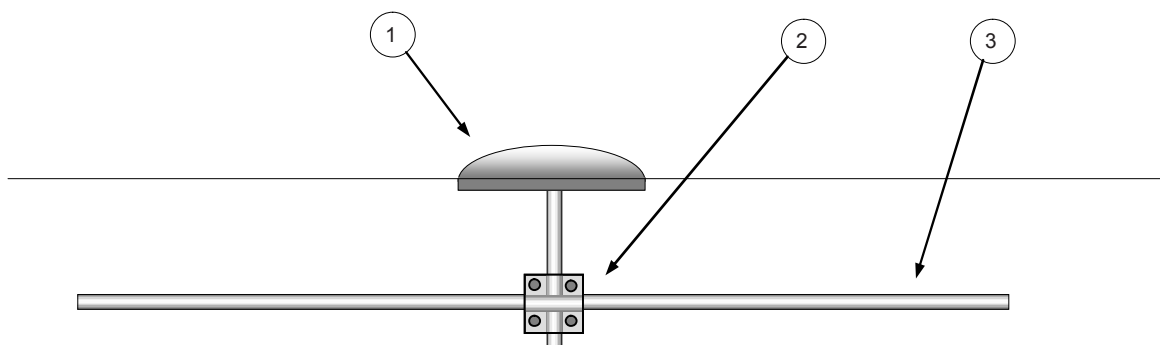

IEC 2705/10

Key

- 1 air-termination stud
- 2 steel conductor connecting to several bars of the reinforcement steel
- 3 steel reinforcement to concrete

Figure E.28 – Example of an air-termination stud used on car park roofs

If the topmost parking area is to be protected against direct lightning strikes, air-termination rods and/or overhead air-termination wires should be employed.

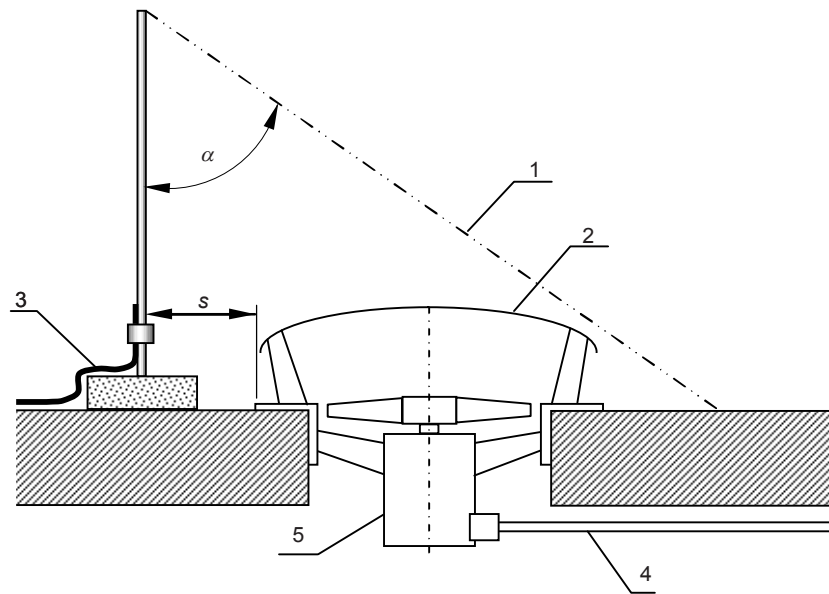

IEC 2706/10

Key

- 1 protection cone
- 2 metallic roof fixture
- 3 horizontal air-termination conductor
- 4 electric power installation line, preferably enclosed in a conductive shield
- 5 electric equipment
- s separation distance according to 6.3
- α protection angle, see Table 2

NOTE The height of the air-termination rod should comply with Table 2.

Figure E.29 – Air-termination rod used for protection of a metallic roof fixture with electric power installations which are not bonded to the air-termination system

In the case of vertical conductors, the area which is possible to reach by hand should be taken into account. The necessary separation distance can be achieved either by provision of barriers or by protective wiring.

Signs should be provided at the entrances drawing attention to the danger of lightning strikes during thunderstorms.

The touch and step voltages may be disregarded if the roof is covered by a layer of asphalt of at least 50 mm thickness. Additionally, the step voltages may be disregarded if the roof is constructed of reinforced concrete with interconnected reinforcement steel with continuity conforming to 4.3.

E.5.2.4.2.2 Flat-roofed, steel-reinforced concrete structures with roofs not accessible to the public

On a flat roof not accessible to the public that incorporates an external air-termination system, air-termination conductors should be installed as shown in Figure E.27. For the equipotential ring conductor on the roof, the metal cladding on the roof parapet may be used as shown in Figure E.24 and Figure E.30.

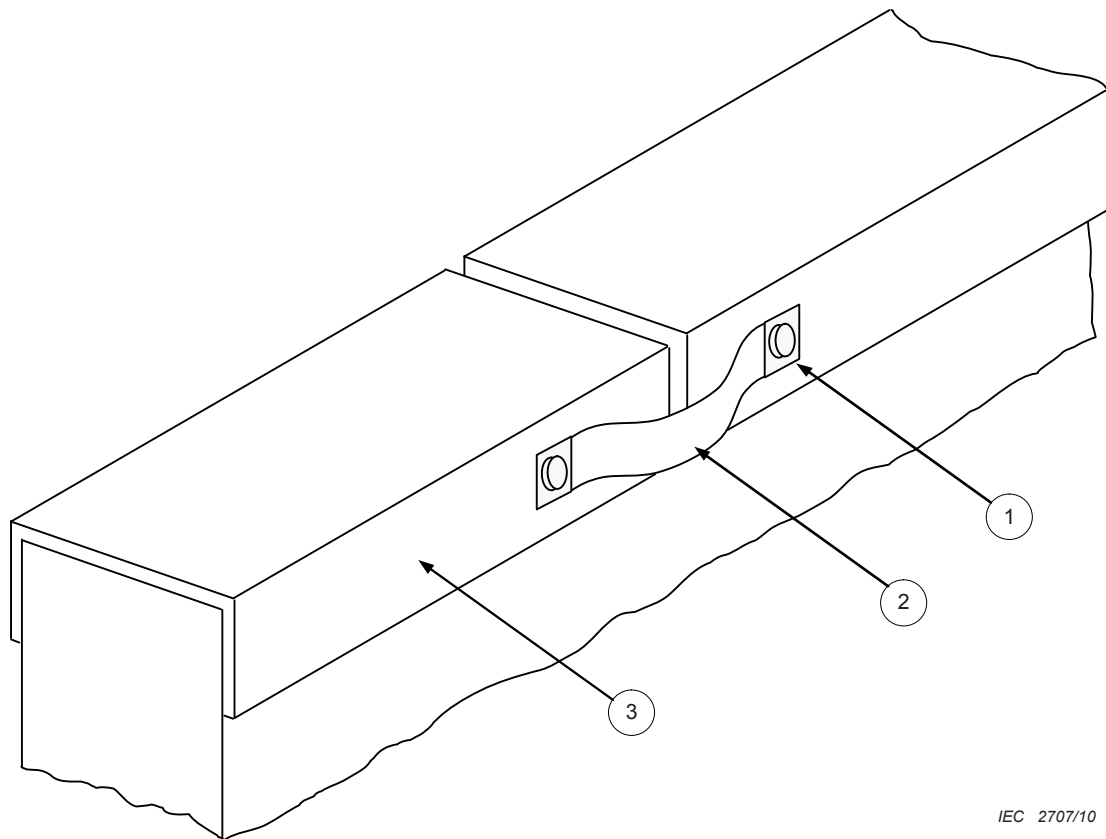

IEC 2707/10

Key

- 1 corrosion-resistant joint
- 2 flexible conductor
- 3 metallic covering of the parapet

NOTE Special attention should be paid to the proper selection of materials and good design of joints and bridging conductors to avoid corrosion.

Figure E.30 – Method of achieving electrical continuity on metallic parapet capping

Figure E.27 shows a method of installing meshed conductors on a roof.

When temporary mechanical damage of the waterproof layer on the roof of a structure is acceptable, the air-termination mesh covering the flat area of the roof may be replaced with natural air-termination conductors consisting of steel reinforcement bars in concrete according to 5.2.4. An acceptable alternative is that the LPS air-termination conductors may be fixed directly on the concrete roof.

In general, a lightning flash to the reinforcement of a concrete roof will damage the waterproof layer. Rainwater may then cause corrosion of the steel-reinforcing rods leading to damage. If reduction in the mechanical strength of concrete due to the corrosion is not permitted, an air-termination system should be installed and preferably bonded to the reinforcement steel, preventing direct lightning flashes to the steel-reinforced concrete.

Metal covering that is provided for mechanical protection of outer walls (parapet capping) may be used as a natural component of the air-termination according to 5.2.5 if there is no risk of fire ignition by melting metal.

Roof coverings of conductive sheets not conforming to Table 3 may be used as air-termination conductors where melting at the point of lightning flashes can be tolerated. If not, the conductive roof sheeting should be protected by an air-termination system of sufficient height (see Figures E.20 and E.26). In this case, the rolling sphere method should be applied. To conform to this method the mesh size has to be smaller and the supports higher than that for an ordinary mesh air-termination system.

When conductive supports are used, the connection to the roof-sheet should withstand partial lightning current.

Figure E.24 shows an example of a natural air-termination using a roof parapet as the air-termination conductor at the edge of the roof area.

When it is acceptable for temporary damage to the facade to occur, and shattered parts of up to 100 mm of broken concrete to fall down from the structure, 5.2 permits the ring conductor on the roof to be replaced by a natural ring conductor consisting of steel reinforcement in concrete.

Metal parts which do not satisfy the conditions of air-terminations stipulated in 5.2.5 may, however, be used to connect the different lightning-current-carrying parts within the domain of the roof area.

E.5.2.4.2.3 Provision of adequate structure shielding

The outer walls and roof of a structure may be used as an electromagnetic shield in order to protect electrical and information-processing equipment within the structure (see Annex B of [C] EN 62305-2:2010 [C] and [C] EN 62305-4[C]).

Figure E.27 provides an example of a steel-reinforced concrete structure using the interconnected reinforcing steel as down-conductors and as electromagnetic shielding of the enclosed space. For more details see [C] EN 62305-4.[C]

Within the domain of the air-termination system on the roof, all conductive parts with at least one dimension larger than 1 m should be interconnected to form a mesh. The meshed shield should be connected to the air-termination system at the roof edge and also at other points within the roof area in accordance with 6.2.

Figures E.24 and E.30 show the construction of air-terminations on structures with conductive skeletons using a roof parapet as a natural air-termination and the steel skeleton as natural down-conductors.

In Figure E.30 an example is given of how to provide electrical continuity of natural components in an LPS.

As a result of the reduced mesh size of steel structures compared with Table 2, the lightning current is distributed over several parallel conductors, resulting in a low electromagnetic impedance and consequently in accordance with 6.3, the separation distances are reduced and the necessary separation distances between the installations and the LPS are not required.

In most structures the roof is the least shielded part of the structure. Therefore particular attention should be paid to improve the shielding efficiency of roof constructions.

When no conductive structural elements are incorporated in the roof, shielding may be improved by reducing the spacing of the roof conductors.

E.5.2.4.2.4 Protection of flush-mounted or protruding roof fixtures

Air-termination rods for the protection of metal, flush-mounted roof fixtures or protruding roof fixtures should be of such height that the fixture to be protected lies fully within the rolling sphere protection space of the air-termination rod or is fully within the cone of the protection angle in accordance with Table 2. The separation distance between the air-termination rods and the roof fixtures should be such that the proximity condition stipulated in 6.3 is satisfied.

Figure E.29 shows an example of roof fixture protection by air-termination rods using the protection angle air-termination design method. The value of the protection angle shall be consistent with the protection level of the LPS stipulated in Table 2.

Metal roof fixtures, not protected by air-termination rods, do not require additional protection if their dimensions do not exceed all of the following values:

- height above the roof level 0,3 m;
- the total area of the fixture 1,0 m²;
- the length of the fixture 2,0 m.

Metal flush mounted roof fixtures not fulfilling these requirements and not being within the requirements for the separation distance according to 6.3 should be bonded to the air-termination system with at least one bonding conductor.

Non-conductive roof fixtures which are not within the protected volume by air-termination rods and which do not protrude by more than 0,5 m above the surface formed by the air-termination system do not require additional protection from air-termination conductors.

Conductive installations, such as electrical conductors or metallic pipes, which lead from flush-mounted roof fixtures into the interior of the building, can conduct a considerable portion of the lightning current into the interior of the building. Where such conductive connections exist, the protruding fixtures on the roof surface should be protected by air-termination systems. If protection by means of an air-termination system is not possible or cost-effective, isolated parts, with lengths corresponding to at least twice the specified separation distance, can be installed in the conductive installations (e.g. compressed air pipes).

Chimneys of non-conductive material should be protected by means of air-termination rods or air-termination rings when they are not within the protection space of an air-termination system. The air-termination rod on a chimney should be of such height that the complete chimney lies within the protection space of the rod.

A lightning flash to a non-conductive chimney is possible when the chimney is not situated within the protection space of an air-termination system, due to the fact that the inner surface of the chimney is covered by a soot deposit possessing a conductivity such that, even in the absence of rain, it is capable of conducting the current of a streamer discharge of great length.

Figure E.22b shows the construction of an air-termination rod on a chimney made of isolating bricks.

E.5.2.4.2.5 Protection of roof fixtures enclosing electrical or information-processing equipment

All roof fixtures of non-conductive or conducting material, which contain electrical and/or information-processing equipment, should lie within the protection space of the air-termination system.

A direct flash into equipment installed inside the protection space of the air-termination system is improbable.

A direct flash into the roof fixture would lead not only to its destruction but would also cause extended damage to the connected electrical and electronic equipment not only in the roof fixtures, but also inside the building.

Roof fixtures on steel structures should also lie in the protection space of the air-termination system. In this case protruding air-termination conductors should be bonded not only to the air-termination system but also to the steel structure directly, if possible. When bonded to the structure they need not conform to the separation distance.

The requirements for roof fixtures should also apply to fixtures installed on vertical surfaces to which a lightning strike is possible, i.e. which can be touched by the rolling sphere.

Figure E.29 and Figure E.31 contain examples of air-termination constructions which protect the roof fixtures of conducting and isolating material enclosing electrical installations. Figure E.31 is only suitable if the separation distance, s , cannot be maintained.

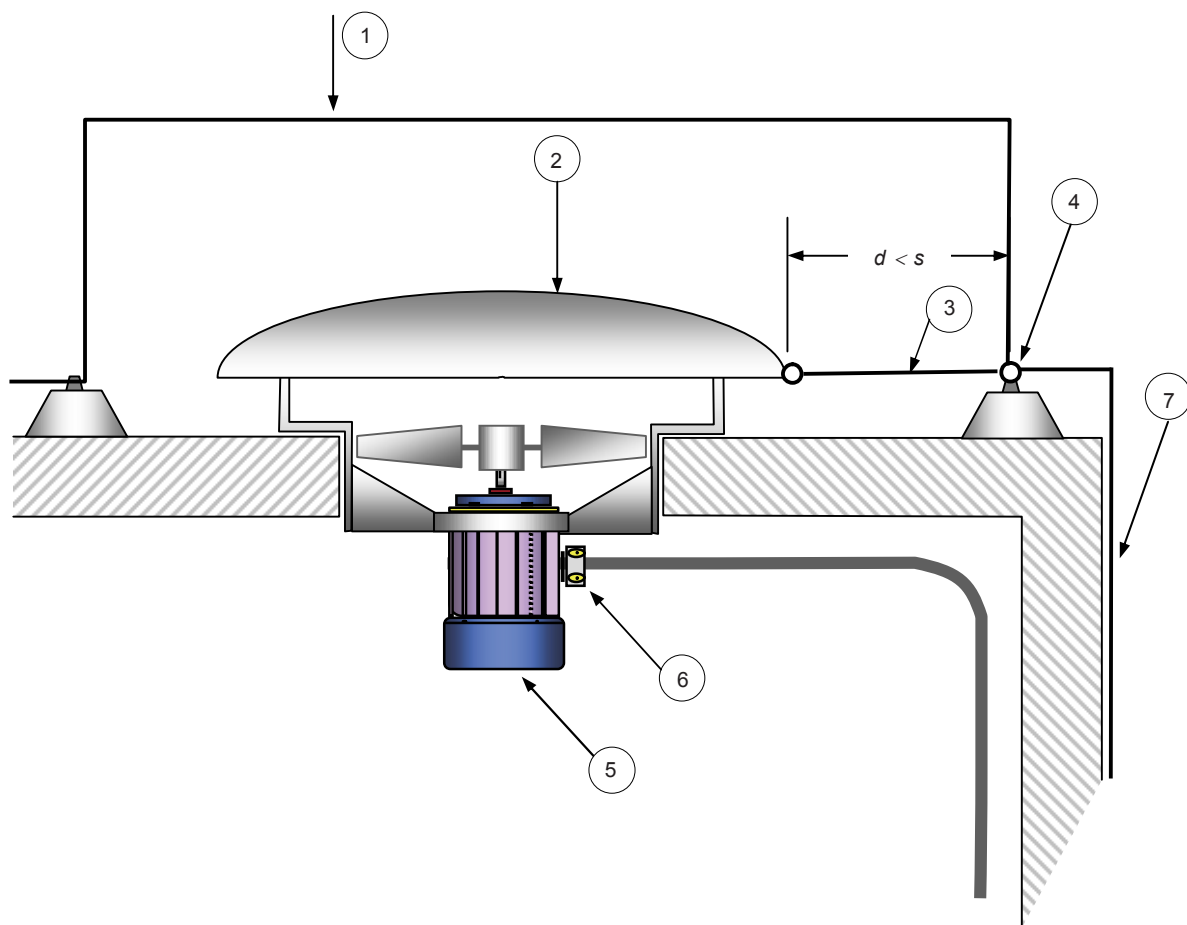

IEC 2708/10

Key

- 1 air-termination conductor
- 2 metallic cover
- 3 bonding conductor
- 4 horizontal air-termination conductor
- 5 electric equipment
- 6 electric power junction box with SPD
- 7 down-conductor

NOTE The enclosed electric equipment is bonded to the air-termination system complying with E.5.2.4.2.6, through the metallic cable shield withstanding a substantial part of the lightning current.

Figure E.31 – Metallic roof fixture protected against direct lightning interception, connected to air-termination system

NOTE If the fixtures need extra protection, SPDs on the active cables connected to it can be provided at roof level.

The required separation distance should be maintained not only in air but also for the path through solid material ($k_m = 0,5$).

E.5.2.4.2.6 Electrical installation protruding from the space to be protected

Antenna on the roof of a structure should be protected against direct lightning flashes by installing the antenna in an already protected volume.

The antenna system should be integrated into the LPS (see also IEC 60728-11 ^[6]).

An isolated external LPS (see Figure E.32a) or a non-isolated external LPS (see Figure E.32b) may be used.

In this latter case, the antenna mast should be bonded to the air-termination system. Then partial lightning currents will be treated as being inside the structure to be protected. The antenna cable should enter the structure preferably at the common entrance for all services or near the main LPS bonding bar. The antenna cable conductive sheath should be bonded to the air-termination system at roof level and to the main bonding bar.

Roof fixtures housing electrical equipment for which the separation distance cannot be maintained, should be bonded to the air-termination system and to the conductive elements of the roof fixtures and the conductive shield of its electrical equipment in accordance with Table 9.

Figure E.31 is an example of the method of bonding a roof fixture with conductive parts to an electrical installation and the air-termination of a structure.

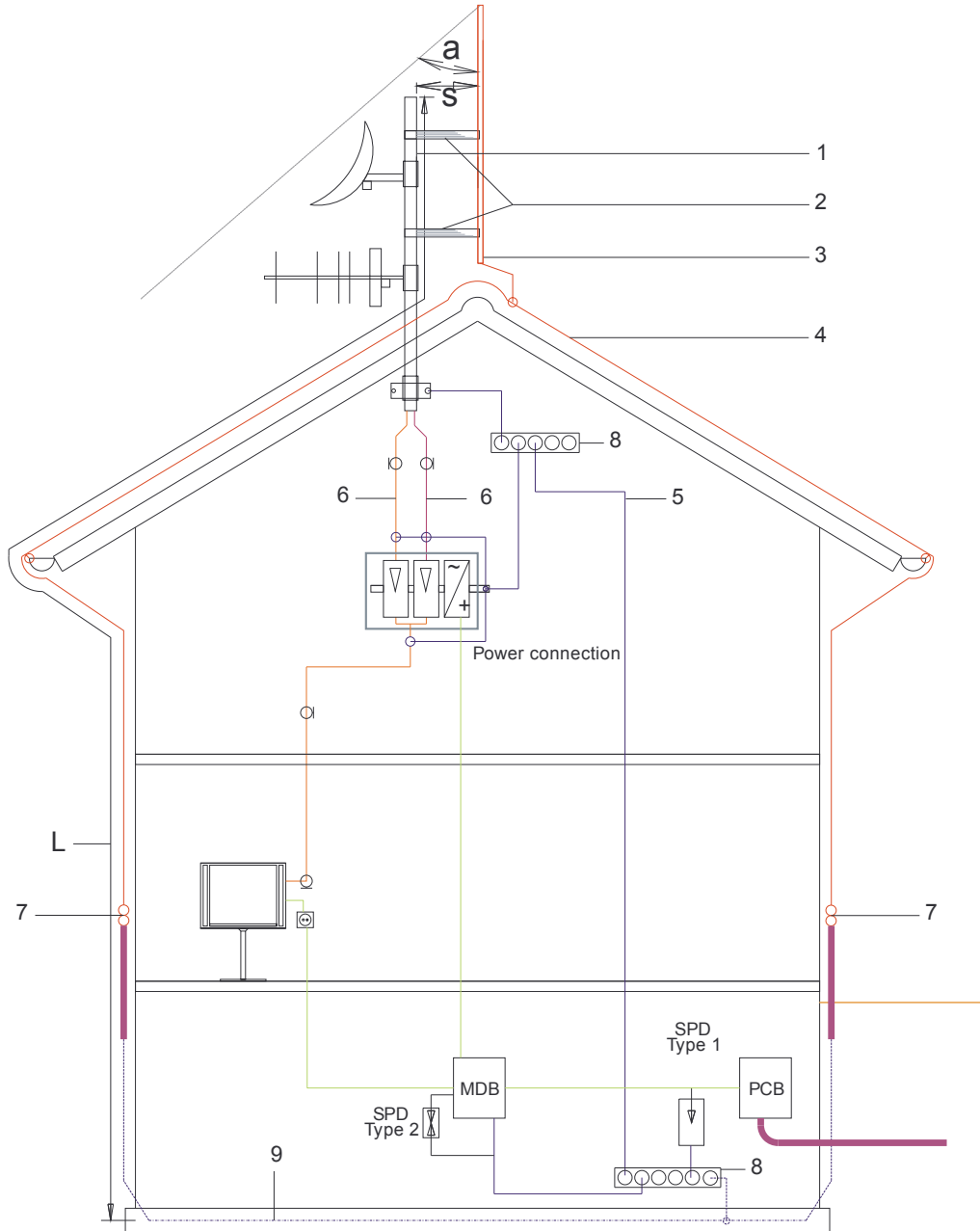

IEC 2709/10

Key

- 1 metallic mast
- 2 isolator
- 3 air-termination rod
- 4 air-termination conductor
- 5 bonding conductor
- 6 antenna cable
- 7 test joint
- 8 equipotential bonding bar
- 9 foundation earth electrode
- α protection angle
- s separation distance
- l length to be considered for separation distance calculation

MDB main distribution box
PCB power connection box

Figure E.32a –TV antenna mast and antennas protected with isolated air-terminations planned according to the protection angle method

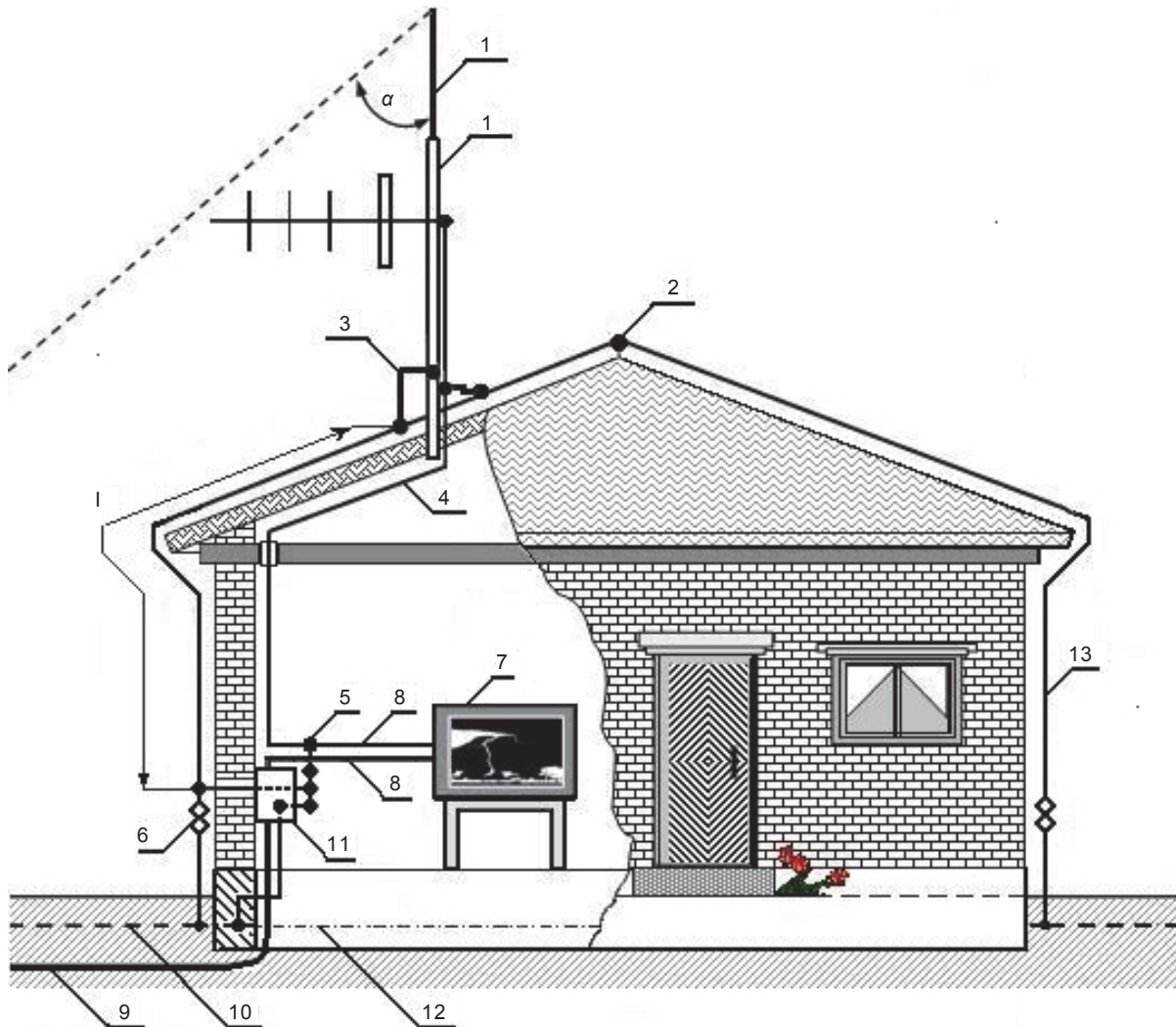

IEC 2710/10

Key

- 1 metallic mast
- 2 horizontal air-termination conductor on the ridge of the roof
- 3 joint between the roof down-conductor and the metallic antenna mast
- 4 antenna cable
- 5 the main bonding bar; metallic shield on the antenna cable is connected to the bonding bar
- 6 test joint
- 7 TV
- 8 parallel routing of the antenna cable and the electric power cable
- 9 electric power cable
- 10 earth-termination system
- 11 the main electric power distribution box with SPD
- 12 foundation earth electrode
- 13 LPS conductor
- α protection angle
- l length to be considered for separation distance calculation

NOTE For small structures only two down-conductors may be sufficient, according to 5.3.3.

Figure E.32b –TV antenna using the mast as an air-termination rod

Figure E.32 – Examples of lightning protection of a house with a TV antenna

E.5.2.4.2.7 Protection of conductive parts on the roof

Conductive items, such as those with insufficient wall thickness, which cannot withstand lightning strikes and which are installed on roofs, and also conductive roof coverings or other

parts on structures which do not meet the requirements for natural air-termination systems according to 5.2.5 and Table 3, and in which a lightning flash cannot be tolerated, should be protected by air-termination conductors.

For the design of the lightning protection for conductive parts on the roof the rolling sphere air-termination design method should be applied (see Figure E.33).

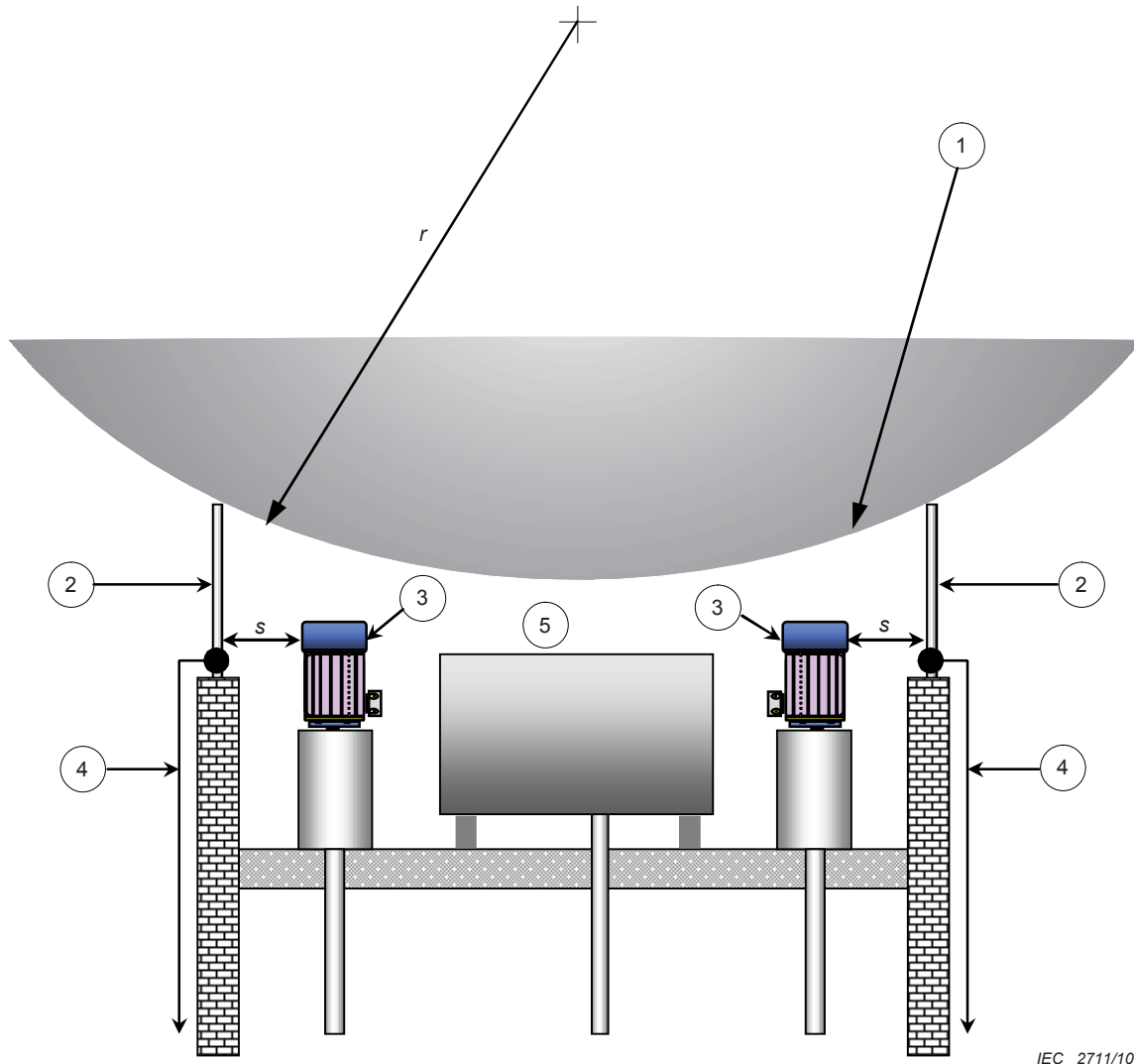

IEC 2711/10

Key

- 1 rolling sphere
- 2 air-termination rod
- 3 electric equipment
- 4 down-conductor
- 5 metallic vessel
- r radius of the rolling sphere, see Table 2
- s separation distance according to 6.3

Figure E.33 – Installation of lightning protection of metallic equipment on a roof against a direct lightning flash

Figure E.31 is an example of the design of an air-termination system protecting a conductive roof fixture against a direct lightning flash when the separation distance, s , cannot be maintained.

E.5.2.4.2.8 Protection of structures covered by soil

For structures incorporating a layer of soil on the roof and where people are not regularly present, a normal LPS may be utilized. The air-termination system should be a meshed air-termination system on top of the soil, or a number of air-termination rods, connected by a buried mesh, conforming to the rolling sphere or protection angle method. If this is not possible, it should be recognized that a buried meshed air-termination system without rods or finials will offer a reduced interception efficiency.

Structures with a roof layer of soil up to 0,5 m where people are regularly present, will need a meshed air-termination system with meshes of 5 m × 5 m to prevent dangerous step voltages. To protect the people on the ground from direct lightning flashes, air-termination rods conforming to the rolling sphere method, may also be necessary. These rods can be replaced by natural air-termination components, such as fences, lighting masts, etc. The height of the air-termination systems shall take into account people's height allowance of 2,5 m along with the necessary separation distances (see also Figure E.3).

If nothing of the kind is available, people should be made aware that during a thunderstorm they may be exposed to a direct lightning flash.

For underground structures with a layer of soil over 0,5 m, measures are under consideration. As long as there is no research available, it is advisable to use the same measures as for layers of soil up to 0,5 m.

For underground structures containing explosives materials, an additional LPS shall be required. Such an additional LPS may be an isolated LPS over the structure. The earthing systems of both protection measures should be interconnected.

E.5.2.5 Natural components

On structures with flat roofs, the metal covering of a roof parapet represents a typical natural component of an LPS air-termination network. Such covering comprises extruded or bent parts of aluminium, galvanized steel or copper in U-form which protect the upper surface of the roof parapet against the influence of weather. The minimum thickness given in Table 3 shall be applied for such an application.

The air-termination conductors, conductors on the roof surface and the down-conductors should be connected to the roof parapet covering.

Conductive bridging should be provided at the joints between sections of parapet covering plates, unless there is good, reliable continuity between them.

Figure E.24 is an example of an air-termination construction using the conductive covering of parapets as a natural air-termination conductor of the LPS.

Conductive parts, such as metal tanks, metal pipework and railings mounted on or extending above a roof surface may be treated as natural components of an air-termination system provided their wall thickness conforms to Table 3.

Vessels and pipework, which contain gas or liquids under high pressure or flammable gas or liquids, should not be used as natural air-terminations. Where this cannot be avoided, the heating effects of lightning current should be taken into account when designing the pipework.

Conductive parts above the roof surface such as metal tanks are often naturally connected to equipment installed within the structure. In order to prevent conduction of the full lightning current through the structure, it is necessary to provide a good connection between such natural components of the LPS and the air-termination mesh.

Figure E.34 is an example which shows details of the bonding of conductive roof fixtures to air-termination conductors.

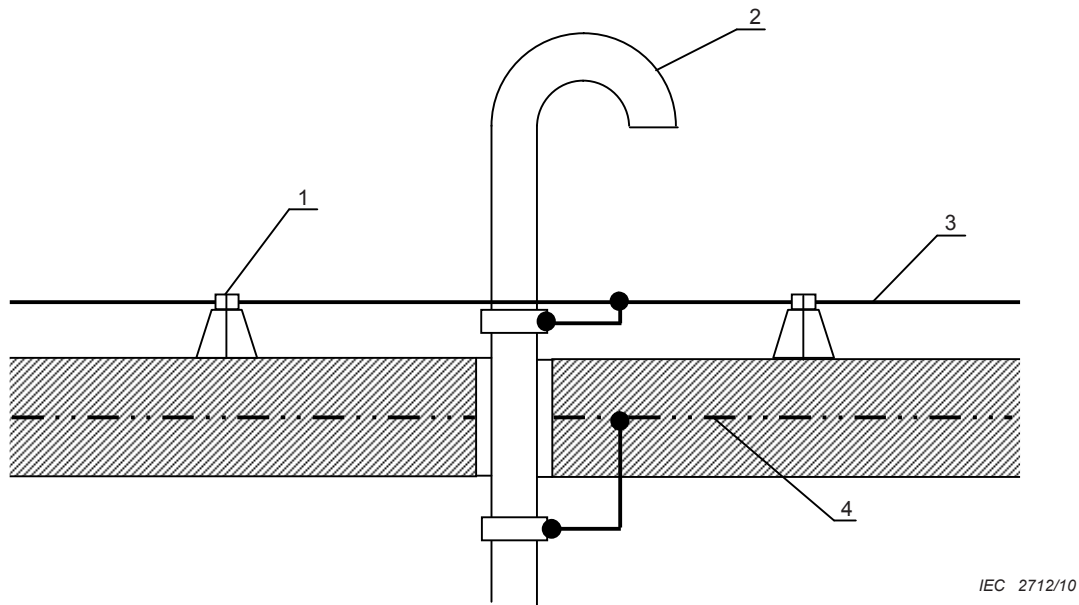

Key

- 1 air-termination conductor fixing
- 2 metallic pipe
- 3 horizontal air-termination conductor
- 4 steel reinforcement within concrete

NOTE 1 The steel pipe should comply with 5.2.5 and Table 6, the bonding conductor should comply with Table 6 and the reinforcement should comply with 4.3. The roof bonding should be watertight.

NOTE 2 In this particular case bonding is provided to the reinforcement of the reinforced concrete structure.

Figure E.34 – Connection of natural air-termination rod to air-termination conductor

Conductive parts above the roof surface such as metal tanks and steel reinforcing rods of concrete should be connected to the air-termination network.

When a direct lightning strike into the conductive part on the roof is not acceptable, the conductive part shall be installed inside the protection space of an air-termination system.

Conductive coverings on facades and equivalent parts of structures where the risk of fire is negligible should be treated in accordance with 5.2.5.

Figure E.35 shows an example of conductive bridging between metal facade plates acceptable in those applications where the plates are to be used as natural down-conductors. Two methods are presented: bridging by flexible metal strapping and bridging by means of self-threading screws.

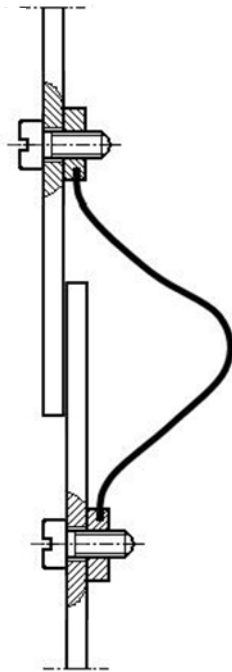

Figure E.35a – Flexible metal strapping bridging

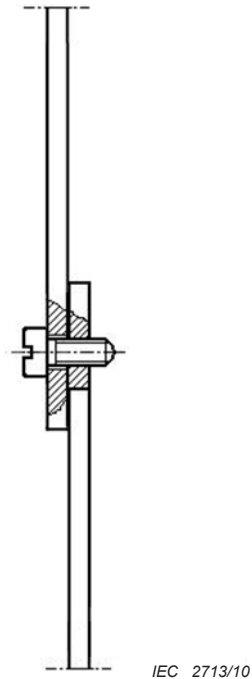

Figure E.35b – Self-tapping screw bridging

NOTE Electrically conducting bridging improves, in particular, the protection against LEMP. More information concerning protection against LEMP can be found in [\[C\] EN 62305-4](#). [\[C\]](#)

Figure E.35 – Construction of the bridging between the segments of the metallic facade plates

E.5.2.6 Isolated air-termination

Air-termination masts adjacent to structures or equipment to be protected are intended to minimize the possibility of lightning strikes to structures within their zone of protection when an isolated LPS is installed.

When more than one mast is installed, they may be interconnected by means of overhead conductors and the proximity of the installations to the LPS should be in accordance with 6.3.

Overhead conductor connections between the masts extend the protected volume and also distribute the lightning current between several down-conductor paths. The voltage drop along the LPS and the electromagnetic interference in the space to be protected are therefore lower than in the case when the overhead conductors are not present.

The strength of the electromagnetic field in the structure is reduced because of the greater distance between the installations within the structure and the LPS. An isolated LPS may also be applied to a structure of reinforced concrete, which will improve the electromagnetic shielding even more. However, for tall structures the construction of an isolated LPS is not practical.

Isolating air-termination systems made of stretched wires on isolating supports could be suitable where a large number of extensive protruding fixtures on the roof surface are to be protected. The isolation of the supports should be adequate for a voltage calculated from the separation distance in accordance with 6.3.

NOTE Environmental conditions (pollution) can lower the voltage breakdown of the air; this should be taken into account when determining the required separation between the isolated air-termination system and the structure.

E.5.3 Down-conductor systems

E.5.3.1 General

The choice of number and position of down-conductors should take into account the fact that, if the lightning current is shared in several down-conductors, the risk of side flash and electromagnetic disturbances inside the structure is reduced. It follows that, as far as possible, the down-conductors should be uniformly placed along the perimeter of the structure and with a symmetrical configuration.

The current sharing is improved not only by increasing the number of down-conductors but also by equipotential interconnecting rings.

Down-conductors should be placed as far as possible away from internal circuits and metallic parts in order to avoid the need for equipotential bonding with the LPS.

It should be remembered that

- the down-conductors should be as short as possible (to keep inductance as small as possible),
- the typical distance between down-conductors is shown in Table 4,
- the geometry of down-conductors and equipotential interconnecting rings has an influence on the value of the separation distance (see 6.3),
- in cantilevered structures the separation distance should also be evaluated with reference to the risk of side-flashing to persons (see E.4.2.4.2).

If it is not possible to place down-conductors at a side, or part of a side, of the building because of practical or architectural constraints, the down-conductors that ought to be on that side should be placed as extra compensating down-conductors at the other sides. The distances between these down-conductors should not be less than one-third of the distances in Table 4.

A variation in spacing of the down-conductors of $\pm 20\%$ is acceptable as long as the mean spacing conforms to Table 4.

In closed courtyards with more than 30 m perimeter, down-conductors have to be installed. Typical values of the distance between down-conductors are given in Table 4.

E.5.3.2 Number of down-conductors for isolated LPS

No additional information.

E.5.3.3 Number of down-conductors for non-isolated LPS

As stated in 5.3.3, a down-conductor should be installed at each exposed corner of the structure, where this is possible. However an exposed corner does not need a down-conductor if the distance between this exposed corner to the nearest down-conductors complies with the following conditions:

- the distance to both adjacent down-conductors is half the distance according to Tables 4 or smaller; or
- the distance to one adjacent down-conductor is one-quarter of the distance according to Tables 4 or smaller.

Inside corners can be disregarded.

E.5.3.4 Construction

E.5.3.4.1 General information

External down-conductors should be installed between the air-termination system and the earth-termination system. Wherever natural components are available they can be used as down-conductor.

If the separation distance between down-conductors and the internal installations, calculated on the basis of the down-conductor spacing according to Table 4, is too large, the number of down-conductors should be increased to meet the required separation distance.

Air-termination systems, down-conductor systems and earth-termination systems should be harmonized to produce the shortest possible path for the lightning current.

Down-conductors should preferably be connected to junctions of the air-termination system network and routed vertically to the junctions of the earth-termination system network.

If it is not possible to make a straight connection because of large roof overhangs, etc. the connection of the air-termination system and the down-conductor should be a dedicated one and not through natural components like rain gutters, etc.

It is permitted, where aesthetic consideration need to be taken into account, to use a thin coating of protective paint or PVC covering over the external down-conductors.

Figure E.36 is an example of an external LPS for a structure with different levels of roof construction and Figure E.25 is an example of the external LPS design for a 60 m high structure with a flat roof with roof fixtures.

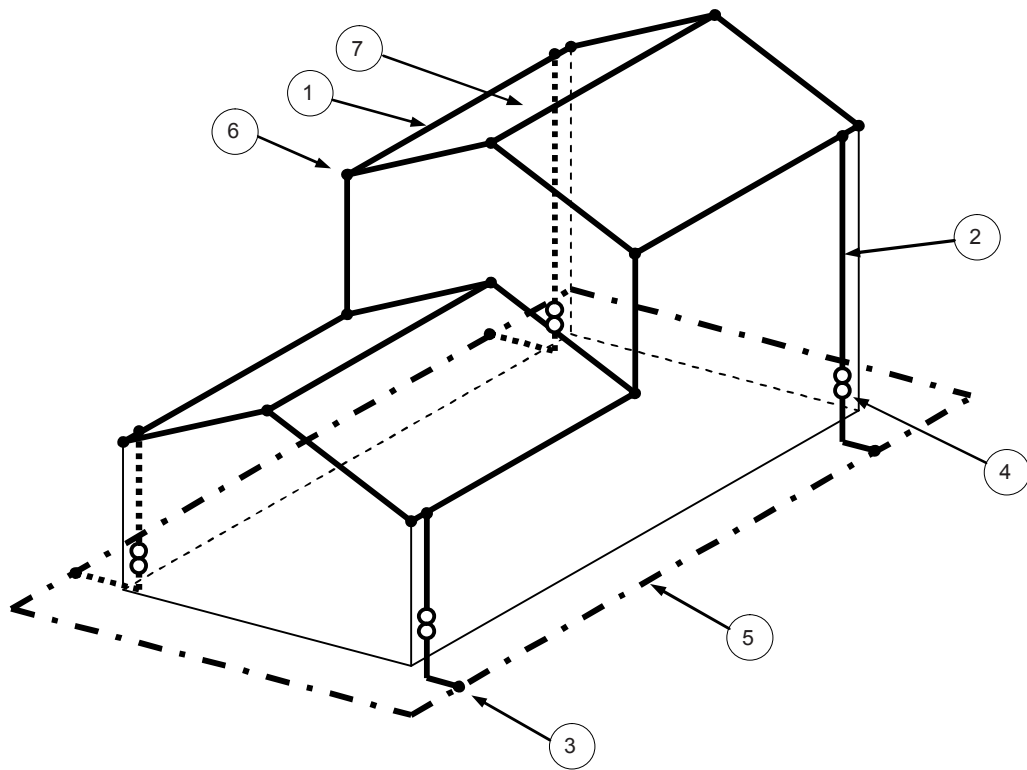

IEC 2714/10

Key

- 1 horizontal air-termination conductor
- 2 down-conductor
- 3 T-type joint – corrosion resistant
- 4 test joint
- 5 type B earthing arrangement, ring earth electrode
- 6 T-type joint on the ridge of the roof
- 7 mesh size

NOTE The distance between the down-conductors should comply with 5.2, 5.3 and Table 4.

Figure E.36 – Installation of external LPS on a structure of insulating material with different roof levels

In structures without extensive continuous conductive parts, the lightning current only flows through the ordinary down-conductor system of the LPS. For this reason the geometry of down-conductors determines the electromagnetic fields within the interior of the structure (see Figure E.37).

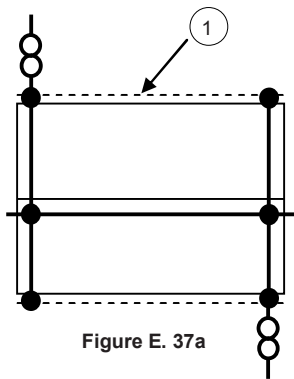

Figure E. 37a

IEC 2715/10

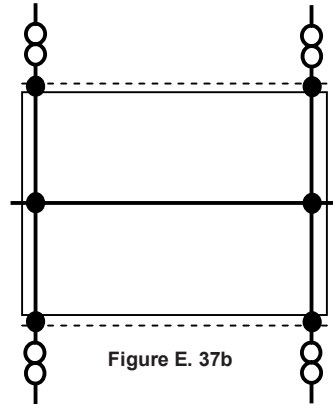

Figure E. 37b

IEC 2716/10

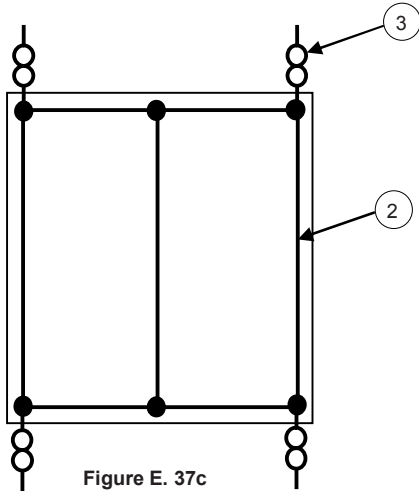

Figure E. 37c

IEC 2717/10

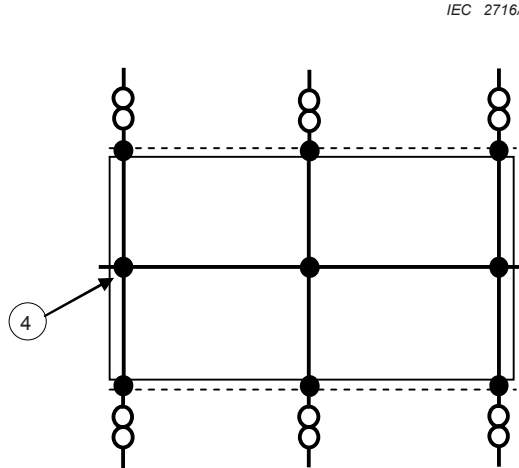

Figure E. 37d

IEC 2718/10

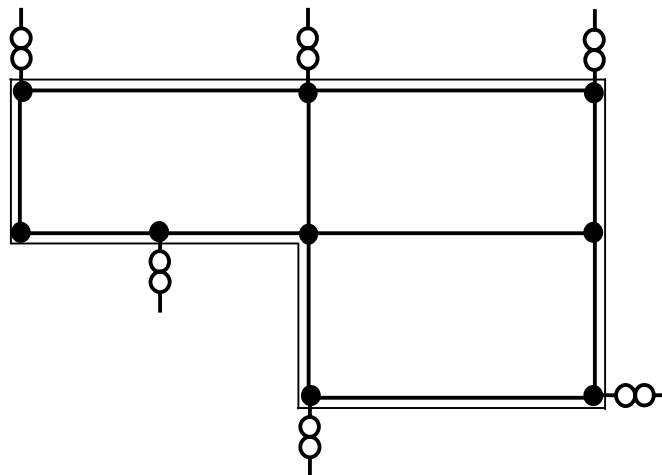

Figure E. 37e

IEC 2719/10

Key

- 1 natural components of the LPS, e.g. gutters
- 2 LPS conductors
- 3 test joint
- 4 joint

NOTE The distance between the down-conductors and the mesh size should comply with the selected lightning protection level according to Tables 2 and 4.

Figure E.37 – Five examples of geometry of LPS conductors

When the number of down-conductors is increased, the separation distance can be reduced according to the coefficient k_c (see 6.3).

According to 5.3.3, at least two down-conductors should be used on a structure.

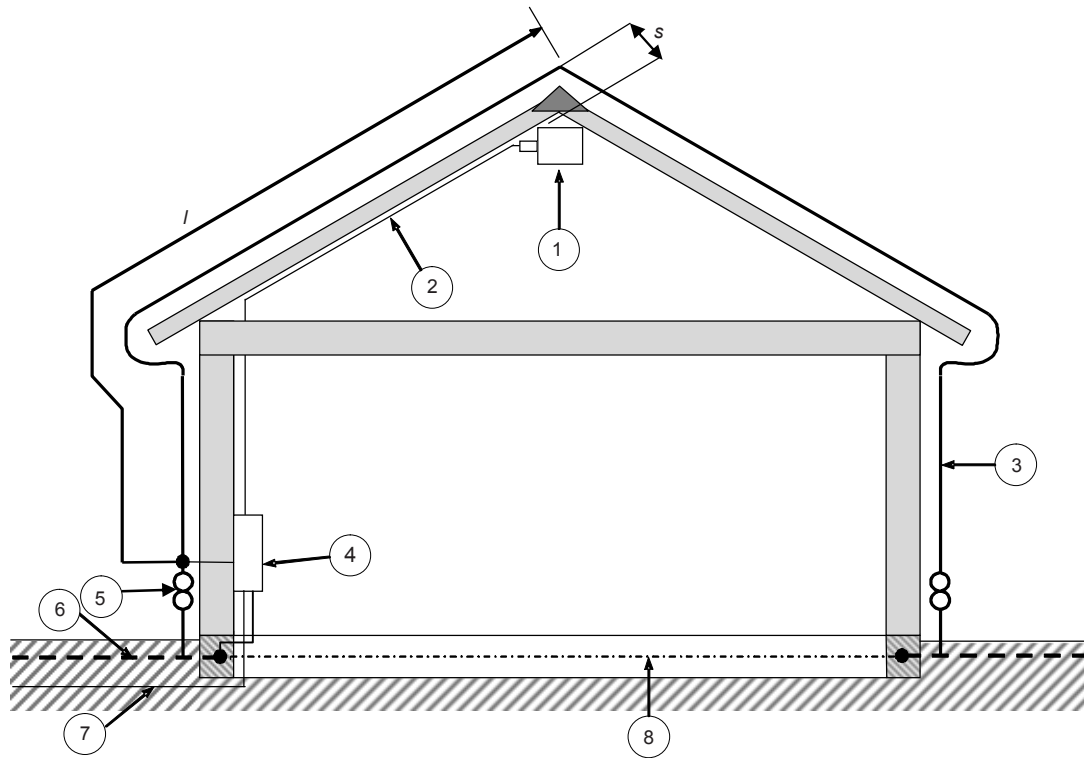

IEC 2720/10

Key

- 1 electric equipment
- 2 electric conductors
- 3 LPS conductors
- 4 main electric power distribution box with SPD
- 5 test joint
- 6 earth-termination system
- 7 electric power cable
- 8 foundation earth electrode
- s separation distance according to 6.3
- l length for the evaluation of the separation distance s

NOTE The example illustrates the problems introduced by electric power or other conductive installations in the roof space of a building.

Figure E.38 – Construction of an LPS using only two down-conductors and foundation earth electrodes

For large structures, such as high-rise apartment buildings and, in particular, industrial and administrative structures, which are often designed as steel skeletons or steel and concrete skeleton structures, or which use steel-reinforced concrete, the conductive structure components may be used as natural down-conductors.

The total impedance of the LPS for such structures is fairly low and they afford a very efficient lightning protection for inner installations. It is particularly advantageous to use conductive wall surfaces as down-conductors. Such conductive wall surfaces might be: reinforced

concrete walls, metallic sheet facade surfaces and facades of prefabricated concrete elements, provided they are connected and interlinked according to 5.3.5.

Figure E.4 provides a detailed description of the proper construction of an LPS using natural LPS components such as interconnected steel.

Use of natural components containing structural steel reduces the voltage drop between the air-termination system and the earth-termination system and the electromagnetic interference caused by lightning current within the structure.

If the air-termination system is connected to the conductive parts of the columns within the structure complex and to the equipotential bonding at ground level, a portion of the lightning current flows through these internal down-conductors. The magnetic field of this partial lightning current influences neighbouring equipment and has to be considered in the design of the internal LPS and electrical and electronic installations. The magnitude of these partial currents depends on the dimensions of the structure and on the number of columns, assuming the current waveform follows the waveform of the lightning current.

If the air-termination system is isolated from the internal columns no current flows through the columns within the structure complex, provided the isolation does not break down. If the isolation breaks down at an unpredicted point, a larger partial current may flow through a particular column or group of columns. The current steepness may increase due to the reduced virtual duration of the wave front caused by the breakdown and the neighbouring equipment is affected to a greater extent than it would be in the case of controlled bonding of columns to the LPS of the structure.

Figure E.10 is an example of the construction of internal down-conductors in a large steel-reinforced concrete structure used for industrial purposes. The electromagnetic environment near to the inner columns shall be considered when planning the internal LPS.

E.5.3.4.2 Non-isolated down-conductors

In structures with extensive conductive parts in the outer walls, the air-termination conductors and the earth-termination system should be connected to the conductive parts of the structure at a number of points. This will reduce the separation distance according to 6.3.

As a result of these connections the conductive parts of a structure are used as down-conductors and also as equipotential bonding bars.

In large, flat structures (typically industrial structures, exhibition halls, etc.) with dimensions over four times the spacing of the down-conductors, extra internal down-conductors should be provided, wherever possible, approximately every 40 m to minimize the separation distance when the lightning current is flowing long distances over a flat roof.

All internal columns and all internal partition walls with conductive parts should be connected with the air-termination system and with the earth-termination system at suitable points.

Figure E.10 shows the LPS of a large structure with internal columns made of steel-reinforced concrete. To avoid dangerous sparking between different conductive parts of the structure, the reinforcement of the columns is connected to the air-termination system and to the earth-termination system. As a result, a portion of the lightning current will flow through these internal down-conductors. However, the current is divided among numerous down-conductors and has approximately the same waveform as the current in the lightning stroke. The steepness of the wavefront, however, is reduced. If these connections are not made and a flashover occurs, only one or a few of these internal down-conductors may carry the current.

The waveform of the flashover current will be considerably steeper than the lightning current, so the voltage induced in neighbouring circuit loops will be considerably increased.

For such structures, it is particularly important that before commencing the design of the structure, the structure's design as well as the design of the LPS should be harmonized so that conductive parts of the structure can be utilized for lightning protection. By means of well-coordinated design, a highly effective LPS is achieved at minimum cost.

Lightning protection of space and persons below an overhanging upper storey, such as a cantilevered upper floor, should be designed according to 4.2.4.2 and Figure E.3.

Direct installation of down-conductors within the external plaster is not recommended since the plaster may be damaged as a result of thermal expansion. Moreover, the plaster may be discoloured as a result of chemical reaction. Damage to the plaster is particularly likely as a result of temperature rise and mechanical forces exerted by lightning current; PVC-covered conductors prevent staining.

E.5.3.5 Natural components

The use of natural down-conductors to maximize the total number of parallel current conductors is recommended as this minimizes the voltage drop in down-conductor systems and reduces the electromagnetic interference within the structure. However, it should be ensured that such down-conductors are electrically continuous along the entire path between the air-termination system and the earth-termination system.

The steel reinforcement in concrete walls should be used as a natural component of the LPS as illustrated in Figure E.27.

Steel reinforcement of newly erected structures should be specified in accordance with E.4.3. If electrical continuity of the natural down-conductors cannot be guaranteed, conventional down-conductors should be installed.

A metallic rain-pipe which satisfies the conditions for natural down-conductors according to 5.3.5 may be used as a down-conductor.

Figures E.22a, E.22b and E.22c show examples of fixing the conductors on the roof and the down-conductors including appropriate geometrical dimensions, and Figures E.22c and E.22d show the connections of the down-conductor to the metallic rain-pipe, the conductive gutters and the earth-termination conductor.

The reinforcing rods of walls or concrete columns and steel structural frames may be used as natural down-conductors.

A metal facade or a facade covering on a structure may be used as a natural down-conductor conforming to 5.3.5.

Figure E.8 shows construction of a natural down-conductor system using metal facade elements and steel reinforcing in the concrete walls as the equipotentialization reference plane to which the equipotentialization bars of the internal LPS are connected.

Connections should be provided at the top of the wallcovering, to the air-termination system and at the bottom of the earth-termination system and to the reinforcing rods of the concrete walls, if applicable.

The distribution of current in such metal facades is more consistent than in reinforced concrete walls. Sheet metal facades comprise individual panels generally of trapezoidal cross-section with a width between 0,6 m and 1,0 m and a length corresponding to the height of the structure. In the case of high-rise structures, the panel length does not correspond to

the structure height due to transport problems. The whole facade then comprises a number of sections mounted one above the other.

For a metal facade, the maximum thermal expansion should be calculated as the difference in length produced by a maximum temperature of the metal facade in sunlight of approximately +80 °C and a minimum temperature of –20 °C.

The temperature difference of 100 °C corresponds to a thermal expansion of 0,24 % for aluminium and 0,11 % for steel.

Thermal expansion of the panels results in movement of the panels with respect to the next section or to the fixtures.

Metal connections, such as those depicted in Figure E.35, encourage uniform current distribution in metal facades and thus reduce the influence of the electromagnetic field inside the structure.

A metal facade produces maximum electromagnetic shielding when it is electrically interconnected over its whole area.

High electromagnetic shielding efficiency of a structure is obtained when permanent bonding of adjacent metal facades is carried out at sufficiently small intervals.

Symmetry of current distribution relates directly to the number of connections.

If stringent requirements with respect to shield attenuation exist and continuous strip windows are incorporated in such a facade, the continuous strip windows should be bridged by means of conductors at small intervals. This may be done by means of metal window frames. The metal facade should be connected to the window frame at short intervals. Generally, each ridge is connected to the horizontal tie-beam of the window frame at intervals not exceeding the spacing of the vertical members of the window construction. Bends and detours should always be avoided (see Figure E.9).

Metal facades comprised of relatively small elements which are not interconnected cannot be used as a natural down-conductor system or for electromagnetic shielding.

More information on the protection of electrical installations and electronics in structures is available in [\[C\]](#) EN 62305-4. [\[C\]](#)

E.5.3.6 Test joint

Test joints facilitate measurements of the earth resistance of earth-termination system.

Test joints conforming to 5.3.6, should be installed in the connection of the down-conductors to the earth-termination system. These joints facilitate the determination by measurement that an adequate number of connections to the earth-termination system still exist. It is thus possible to validate the existence of continuous connections between the test joint and the air-termination system or the next bonding bar. On tall structures, ring-conductors are connected to the down-conductors, which may be installed in the wall and invisible to the eye; their existence may only be confirmed by electric measurement.

Figure E.39a through Figure E.39d show examples of test joint designs, which may be installed on the inner or outer wall of a structure or in a test box in the earth outside the structure (see Figure E.39b). To make the continuity measurements possible, some conductors may have to have isolating sheaths on critical sections.

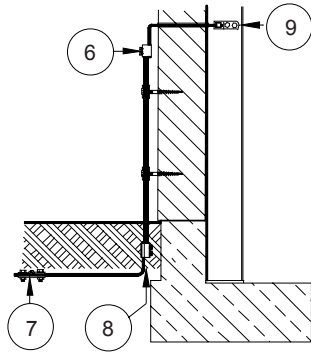

Figure E.39a

IEC 2721/10

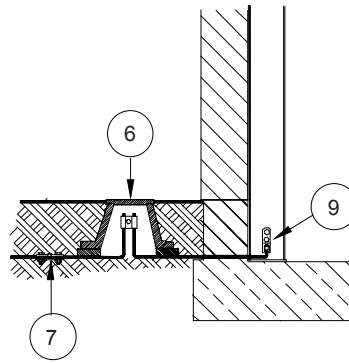

Figure E.39b

IEC 2722/10

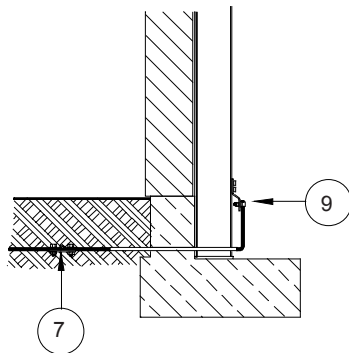

Figure E.39c

IEC 2723/10

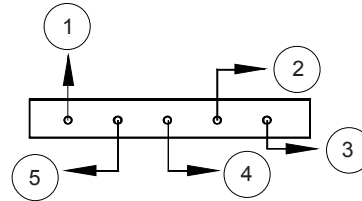

Figure E.39d

IEC 2724/10

Alternative 1 – Test joint on wall

- 1 down-conductor
- 2 type B earth electrode, if applicable
- 3 type A earth electrode, if applicable
- 4 foundation earth electrode
- 5 bonding to the internal LPS
- 6 test joint on the wall
- 7 corrosion-resistant T-joint in soil
- 8 corrosion-resistant joint in soil
- 9 joint between lightning conductor and a steel girder

Alternative 2 – Test joint in the floor

- 1 down-conductor
- 2 type A earth electrode, if applicable
- 3 bonding bar of the internal LPS
- 4 type B – Ring earth electrode
- 5 type B – Ring earth electrode
- 6 test joint in the floor
- 7 corrosion-resistant, T-joint in soil
- 8 corrosion-resistant joint in soil
- 9 joint between lightning conductor and a steel girder

NOTE 1 The test joint detailed in Figure E.39d should be installed on the inner or outer wall of a structure or in a test box in the earth outside the structure.

NOTE 2 To make the loop resistance measurements possible, some of the connecting conductors should have isolating sheaths along critical sections.

Figure E.39 – Four examples of connection of earth-termination to the LPS of structures using natural down-conductors (girders) and detail of a test joint

If it makes sense (e.g. in the case of earthing connections to steel columns via connecting conductors), connections from natural down-conductors to earth-termination electrodes may be provided with isolated conductor segments and testing joints. Special reference earth electrodes should be installed to facilitate monitoring of the earth-termination system of an LPS.

E.5.4 Earth-termination system

E.5.4.1 General

The LPS designer and the LPS installer should select suitable types of earth electrodes and should locate them at safe distances from entrances and exits of a structure and from the external conductive parts in the soil, such as cables, metal ducts, etc. Hence the LPS designer and the LPS installer should make special provisions for protection against dangerous step voltages in the vicinity of the earth-termination networks if they are installed in areas accessible to the public (see Clause 8).

The recommended value of the overall earth resistance of 10Ω is fairly conservative in the case of structures in which direct equipotential bonding is applied. The resistance value should be as low as possible in every case but especially in the case of structures endangered by explosive material. Still the most important measure is equipotential bonding.

The embedded depth and the type of the earth electrodes should be such as to minimize the effects of corrosion, soil drying and freezing and thereby stabilize the equivalent earth resistance.

It is recommended that the first half metre of a vertical earth electrode should not be regarded as being effective under frost conditions.

Deep-driven earth electrodes can be effective in special cases where soil resistivity decreases with depth and where substrata of low resistivity occur at depths greater than those to which rod electrodes are normally driven.

When the metallic reinforcement of concrete is used as an earth electrode, special care should be exercised at the interconnections to prevent mechanical splitting of the concrete.

If the metal reinforcement is also used for the protective earth, the most severe measure in respect of thickness of the rods and the connection should be chosen. In this case, larger sizes of reinforcement bars could be considered. The need for short and straight connections for the lightning protection earthing should be recognized at all times.

NOTE In the case of pre-stressed concrete, consideration should be given to the consequences of the passage of lightning discharge currents, which may produce unacceptable mechanical stresses.

E.5.4.2 Types of earth electrode arrangements

E.5.4.2.1 Type A arrangement

The type A earth-termination system is suitable for low structures (for example family houses), existing structures or an LPS with rods or stretched wires or for an isolated LPS.

This type of arrangement comprises horizontal or vertical earth electrodes connected to each down-conductor.

Where there is a ring conductor, which interconnects the down-conductors, in contact with the soil the earth electrode arrangement is still classified as type A if the ring conductor is in contact with the soil for less than 80 % of its length.

In a type A arrangement the minimum number of earth electrodes should be one for each down-conductor and at least two for the whole LPS.

E.5.4.2.2 Type B arrangement

The type B earth-termination system is preferred for meshed air-termination systems and for LPS with several down-conductors.

This type of arrangement comprises either a ring earth electrode external to the structure, in contact with the soil for at least 80 % of its total length, or a foundation earth electrode.

For bare solid rock, only the type B earthing arrangement is recommended.

E.5.4.3 Construction

E.5.4.3.1 General

Earth-termination systems should perform the following tasks:

- conduction of the lightning current into the earth;
- equipotential bonding between the down-conductors;
- potential control in the vicinity of conductive building walls.

The foundation earth electrodes and the type B ring-type earth electrodes meet all these requirements. Type A radial earth electrodes or deep-driven vertical earth electrodes do not meet these requirements with respect to equipotential bonding and potential control.

The structure foundations of interconnected steel-reinforced concrete should be used as foundation earth electrodes. They exhibit very low earthing resistance and perform an excellent equipotentialization reference. When this is not possible, an earth-termination system, preferably a type B ring earth electrode, should be installed around the structure.

E.5.4.3.2 Foundation earth electrodes

A foundation earth electrode, which conforms to 5.4.4, comprises conductors, which are installed in the foundation of the structure below ground. The length of additional earth electrodes should be determined using the diagram in Figure 3.

Foundation earth electrodes are installed in concrete. They have the advantage that, if the concrete is of adequate construction and covers the foundation earth electrode by at least 50 mm, they are reasonably protected against corrosion. It should also be remembered that reinforcing steel rods in concrete generate the same magnitude of galvanic potential as copper conductors in soil. This offers a good engineering solution to the design of earth-termination systems for reinforced concrete structures (see E.4.3).

Metals used for earth electrodes should conform to the materials listed in Table 7, and the behaviour of the metal with respect to corrosion in the soil should always be taken into account. Some guidance is given in 5.6. When guidance for particular soils is not available, the experience with earth-termination systems in neighbouring plants, with soil exhibiting similar chemical properties and consistency, should be ascertained. When the trenches for earth electrodes are refilled, care should be taken that no fly ash, lumps of coal or building rubble is in direct contact with the earth electrode.

A further problem arises from electrochemical corrosion due to galvanic currents. Steel in concrete has approximately the same galvanic potential in the electrochemical series as copper in soil. Therefore, when steel in concrete is connected to steel in soil, a driving galvanic voltage of approximately 1 V causes a corrosion current to flow through the soil and the wet concrete and dissolve steel in soil.

Earth electrodes in soil should use copper, copper coated steel or stainless steel conductors where these are connected to steel in concrete.

At the perimeter of a structure, a metal conductor, in accordance with Table 7, or a galvanized steel strip, should be installed in the strip foundation and be taken upwards with connection leads to the designated terminal points of the lightning down-conductor test joints.

Upward routing of the conductors connected to the down-conductors can be performed on the brickwork, within the plaster or within the wall. The steel connection leads installed within the wall may penetrate the asphalt-saturated paper normally used between the foundation and the brick wall. Piercing of the humidity barrier at this point generally presents no problem.

The water-insulating layer often inserted below the structure foundation to reduce the humidity in basement floors provides consistent electrical isolation. The earth electrode should be installed under the foundation in the sub-concrete. An agreement should be obtained with the builder for the design of the earth-termination system.

Where the groundwater level is high, the foundation of the structure should be isolated from subsoil water. A sealing waterproof layer should be applied to the outer surface of the foundation, which also provides electrical isolation. The usual practice in establishing such a waterproof foundation is to pour a clean layer of concrete approximately 10 cm to 15 cm in depth on the bottom of the foundation pit, onto which the isolation, and later the concrete foundation, is laid.

A foundation earth electrode consisting of a network of mesh size not exceeding 10 m shall be installed in the clean concrete layer at the bottom of the foundation pit.

A conductor in accordance with Table 7 shall connect the meshed earth-termination with the reinforcement in the foundation, the ring earth electrodes, and the down-conductors external to the damp-proof membrane. Where permitted, pressure-waterproof bushings may be used to penetrate the insulation.

When penetration of the conductor through the isolation layer is not permitted by the building contractor, connections should be made to the earth-termination outside the structure.

Figure E.40 shows three different examples of how to install foundation earth electrodes on a structure with waterproofed foundations.

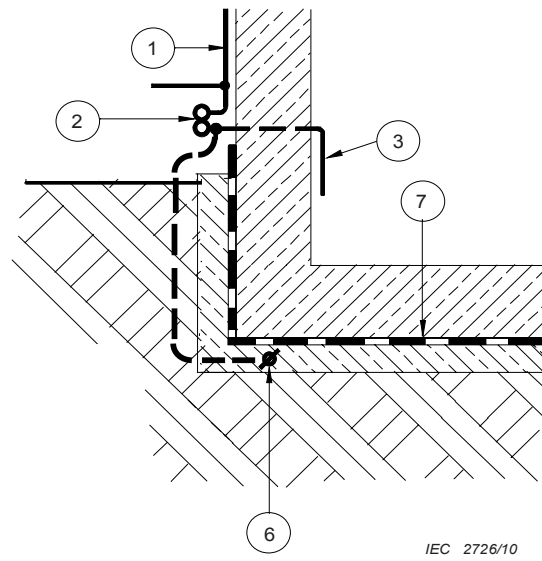
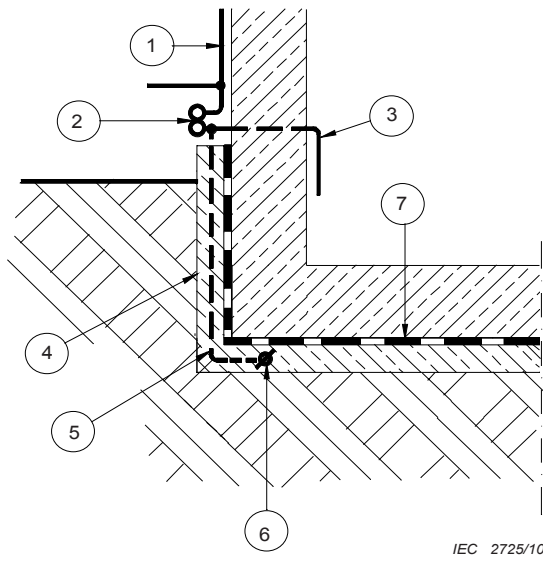

Figure E.40a – Isolated foundation with foundation earth electrode in the non-reinforced concrete layer below the bitumen insulation

Figure E.40b – Isolated foundation with earth-termination conductor partly passing through the soil

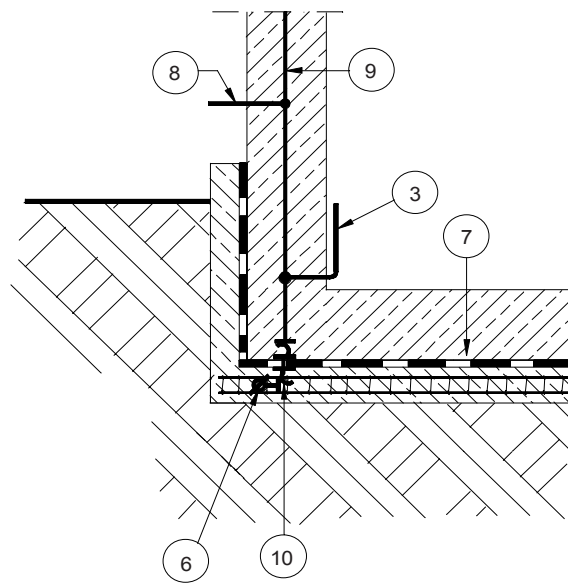

Figure E.40c – Connection from the foundation earth electrode to the steel reinforcement passing through the damp proof membrane

Key

- 1 down-conductor
- 2 test joint
- 3 bonding conductor to the internal LPS
- 4 non-reinforced layer of concrete
- 5 connecting conductor of the LPS
- 6 foundation earth electrode
- 7 damp proof membrane, watertight insulating layer
- 8 connecting conductor between steel reinforcement and the test joint
- 9 steel reinforcement in concrete
- 10 watertight bushing through the damp proof membrane

NOTE Permission from the structure constructor is necessary.

Figure E.40 – Construction of foundation earth ring for structures of different foundation design

Several solutions of an adequate connection of the earth-termination on structures with isolated foundation are also illustrated.

Figures E.40a and E.40b show connections external to the insulation, so that the insulation is not damaged; Figure E.40c shows a watertight bushing through the insulation to avoid compromising the integrity of the damp-proof membrane.

E.5.4.3.3 Type A – Radial and vertical earth electrodes

Radial earth electrodes should be connected to the lower ends of the down-conductors by using test joints. Radial earth electrodes may be terminated by vertical earth electrodes if appropriate.

Each down-conductor should be provided with an earth electrode.

Figure E.41 shows examples of type A earth electrodes where Figure E.41a shows how a lightning conductor in accordance with Table 7 is pushed into the soil using special driving rods. This earthing technique has several practical advantages and avoids the use of clamps and joints in the soil. Sloped or vertical earth electrodes are generally hammered in.

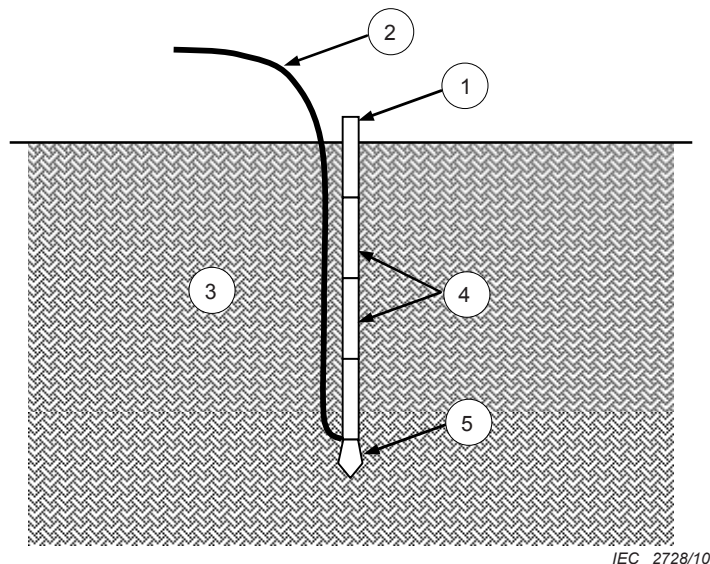

Key

- 1 short upper-most driving rod
- 2 earthing conductor
- 3 soil
- 4 short driving rods
- 5 driving steel dart

NOTE 1 A continuous wire conductor is driven into the soil by means of short driving rods. The electrical continuity of the earth electrode conductor is of great advantage; using this technique, no joints are introduced into the earth electrode conductor. Short driving rod segments are also easy to handle.

NOTE 2 The short upper-most driving rod may be removed.

NOTE 3 The uppermost part of the earthing conductor may have an insulating jacket.

Figure E.41a – Example of a type A earthing arrangement with a vertical conductor type electrode

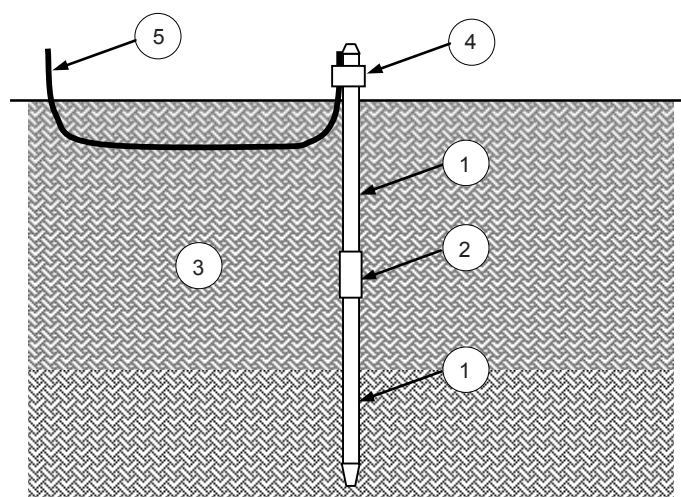

IEC 2729/10

Key

- 1 extensible earth rod
- 2 rod coupling
- 3 soil
- 4 conductor to rod clamp
- 5 earthing conductor

Figure E.41b – Example of a type A earthing arrangement with a vertical rod type electrode

Figure E.41 – Two examples of vertical electrodes in type A earthing arrangement

There are also other types of vertical electrodes. It is essential to ensure a permanent conducting connection along the whole length of the electrode during the service life of the LPS.

During installation it is advantageous to measure the earthing resistance regularly. The driving may be interrupted as soon as the earthing resistance stops decreasing. Additional electrodes can then be installed in more suitable locations.

The earth electrode should have sufficient separation from existing cables and metal pipes in the earth, and due allowance should be made for the earth electrode departing from its intended position during driving. The separation distance depends on the electrical impulse strength and resistivity of the soil and the current in the electrode.

In the type A arrangement, vertical earth electrodes are more cost-effective and give more stable earthing resistances in most soils than horizontal electrodes.

In some cases it may be necessary to install the earth electrodes inside the structure, for example in a basement or cellar.

NOTE Special care should be taken to control step voltages by taking equipotentialization measures according to Clause 8.

If there is a danger of an increase in resistance near to the surface (e.g. through drying out), it is often necessary to employ deep-driven earth electrodes of greater length.

Radial earth electrodes should be installed at a depth of 0,5 m or deeper. A deeper electrode ensures that in countries in which low temperatures occur during the winter, the earth electrode is not situated in frozen soil (which exhibits extremely low conductivity). An additional benefit is that deeper earth electrodes give a reduction of the potential differences at the earth surface and thus lower step voltages reducing the danger to living creatures on

the earth surface. Vertical electrodes are preferred to achieve a seasonally-stable earthing resistance.

When the type A earthing arrangement is provided, the necessary potential equalization for all electrodes is achieved by means of equipotential bonding conductors and bonding bars .

E.5.4.3.4 Type B – Ring earth electrodes

For structures using isolating material such as brickwork or wood with no steel-reinforced foundation, a type B earth-termination should be installed conforming to 5.4.2.2. Alternatively a type A arrangement incorporating equipotential bonding conductors may be used. In order to reduce the equivalent earth resistance, the type B earthing arrangement may be improved, if necessary, by adding vertical earth electrodes, or radial earth electrodes conforming to 5.4.2.2. Figure 3 gives the requirements regarding the minimum length of earth electrodes.

The clearance and depth for a type B earth electrode, as mentioned in 5.4.3, are optimal in normal soil conditions for the protection of persons in the vicinity of the structure. In countries with low winter temperatures, the appropriate depth of earth electrodes should be considered.

Type B earth electrodes also perform the function of potential equalization between the down-conductors at ground level, since the various down-conductors give different potentials due to the unequal distribution of lightning currents due to variations in the earth resistance and different lengths in the above ground conductor current paths. The different potentials result in a flow of equalizing currents through the ring earth electrode, so that the maximum rise in potential is reduced and the equipotential bonding systems connected to it within the structure are brought to approximately the same potential.

Where structures belonging to different owners are built closely to each other, it is often not possible to install a ring earth electrode that will fully surround the structure. In this case the efficiency of the earth-termination system is somewhat reduced, since the conductor ring acts partly as a type B electrode, partly as a foundation earth and partly as an equipotential bonding conductor.

Where large numbers of people frequently assemble in an area adjacent to the structure to be protected, further potential control for such areas should be provided. More ring earth electrodes should be installed at distances of approximately 3 m from the first and subsequent ring conductors. Ring electrodes further from the structure should be installed more deeply below the surface i.e. those at 4 m from the structure at a depth of 1 m, those at 7 m from the structure at a depth of 1,5 m and those at 10 m from the structure at a depth of 2 m. These ring earth electrodes should be connected to the first ring conductor by means of radial conductors.

When the area adjacent to the structure is covered with a 50 mm thick slab of asphalt of low conductivity, sufficient protection is provided for people making use of the area.

E.5.4.3.5 Earth electrodes in rocky soil

During construction, a foundation earth electrode should be built into the concrete foundation. Even where a foundation earth electrode has a reduced earthing effect in rocky soil, it still acts as an equipotential bonding conductor.

At the test joints, additional earth electrodes should be connected to the down-conductors and foundation earth electrodes.

Where a foundation earth electrode is not provided, a type B arrangement (a ring earth electrode) should be used instead. If the earth electrode cannot be installed in the soil and has to be mounted on the surface, it should be protected against mechanical damage.

Radial earth electrodes lying on or near the earth surface should be covered by stones or embedded in concrete for mechanical protection.

When the structure is situated close to a road, if possible, a ring earth electrode should be laid beneath the road. However, where this is not possible over the whole length of the exposed road segment, such equipotential control (typically a type A arrangement) should be provided at least in the vicinity of the down-conductors.

For potential control in certain special cases, a decision should be made as to whether to install a further partial ring in the vicinity of the structure entrance, or to artificially increase the resistivity of the surface layer of the soil.

E.5.4.3.6 Earth-termination systems in large areas

An industrial plant typically comprises a number of associated structures, between which a large number of power and signal cables are installed.

The earth-termination systems of such structures are very important for the protection of the electrical system. A low impedance earth system reduces the potential difference between the structures and so reduces the interference injected into the electrical links.

A low earth impedance can be achieved by providing the structure with foundation earth electrodes and additional type B and type A earth arrangements conforming to 5.4.

Interconnections between the earth electrodes, the foundation earth electrodes and the down-conductors should be installed at the test joints. Some of the test joints should also be connected to the equipotential bars of the internal LPS.

Internal down-conductors, or internal structural parts used as down-conductors, should be connected to an earth electrode and the reinforcement steel of the floor to avoid step and touch voltages. If internal down-conductors are near expansion joints in the concrete, these joints should be bridged as near to the internal down-conductor as possible.

The lower part of an exposed down-conductor should be insulated by PVC tubing with a thickness of at least 3 mm or with equivalent insulation.

In order to reduce the probability of direct lightning flashes to cable routes in the ground, an earthing conductor and, in the case of wider cable routes, a number of earthing conductors should be installed above the cable routes.

By interconnecting the earths of a number of structures, a meshed earthing system is obtained as shown in Figure E.42.

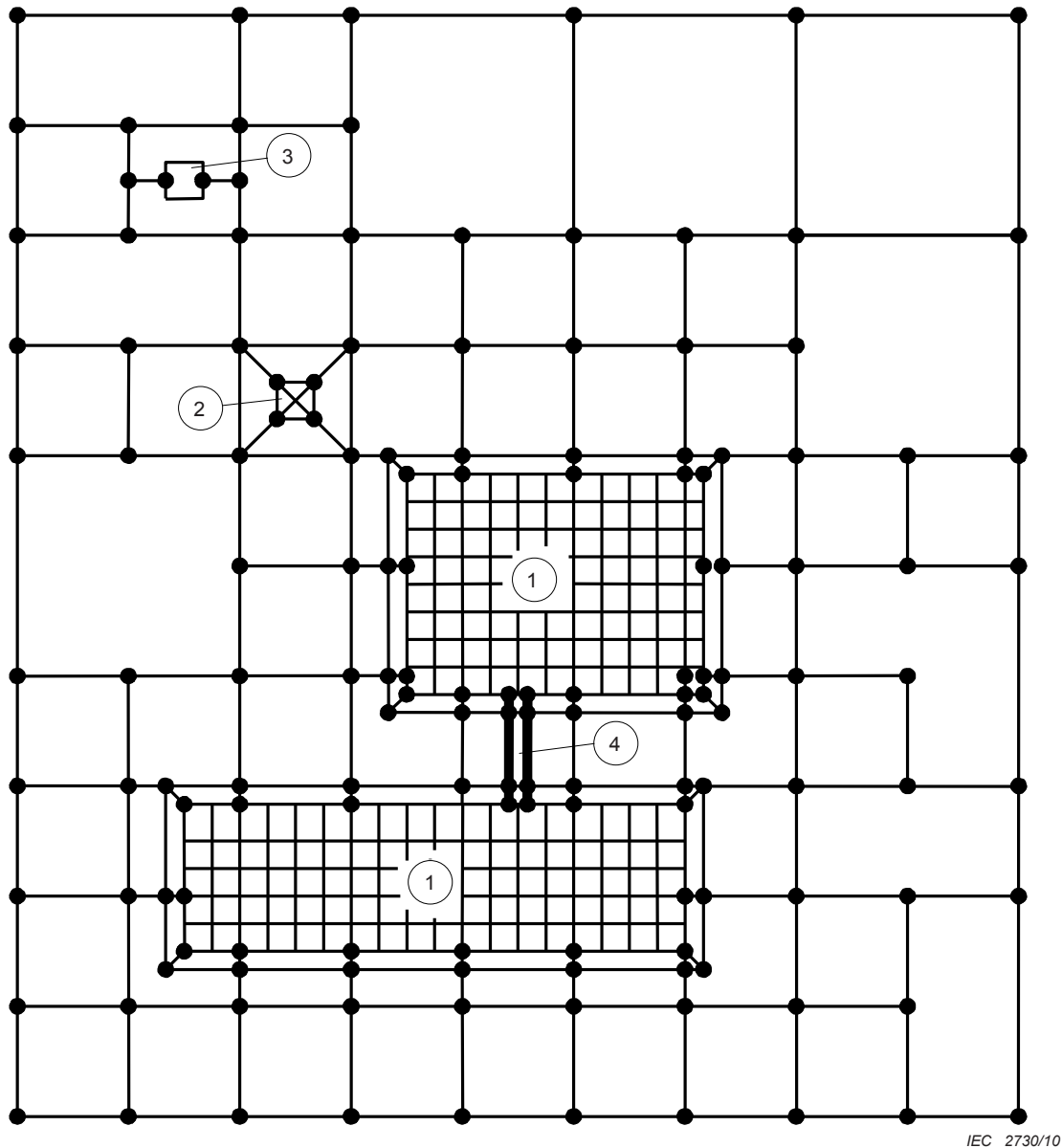

Key

- 1 building with meshed network of the reinforcement
- 2 tower inside the plant
- 3 stand-alone equipment
- 4 cable trenches

NOTE This system gives a low impedance between buildings and has significant EMC advantages. The size of the meshes next to buildings and other objects may be in the order of 20 m × 20 m. Beyond a 30 m distance they may be enlarged to the order of 40 m × 40 m.

Figure E.42 – Meshed earth-termination system of a plant

Figure E.42 shows the design of a meshed earth electrode network, including cable trenches, between associated structures of lightning-protected buildings. This will give a low impedance between buildings and has significant LEMP protection advantages.

E.5.5 Components

☐ Components of LPS should withstand the electromagnetic effects of lightning current and predictable accidental stresses without being damaged. This can be achieved by choosing components that have successfully been tested in accordance with the EN 50164 series.

All components shall comply with the EN 50164 series. ☐

NOTE Distances between fixings are given in Table E.1.

E.5.6 Materials and dimensions

E.5.6.1 Mechanical design

The lightning protection designer shall consult with the persons responsible for the structure, on mechanical design matters following the completion of the electrical design.

Aesthetic considerations are particularly important as well as the correct selection of materials to limit the risk of corrosion.

The minimum size of lightning protection components for the various parts of the LPS are listed in Tables 3, 6, 7, 8 and 9.

The materials used for the LPS components are listed in Table 5.

NOTE Components such as clamps and rods selected in accordance with the future EN 50164 series are adequate.

The LPS designer and the LPS installer should verify the fitness of purpose of the materials used. This can be achieved, for example, by requiring test certificates and reports from the manufacturer, demonstrating that materials have successfully passed quality tests.

The LPS designer and the LPS installer should specify conductor fasteners and fixtures which will withstand the electrodynamic forces of lightning current in the conductors and also allow for the expansion and contraction of conductors due to the relevant temperature rise according to the EN 50164 series.

Connections between sheet metal panels should be compatible with the panel material, represent a minimum contact surface area of 50 mm^2 and be capable of withstanding the electrodynamic forces of a lightning current and the corrosion threats of the environment.

When excessive temperature rise is a concern for the surface to which the components are to be attached because it is flammable or has a low melting point, either larger conductor cross-sections should be specified, or other safety precautions should be considered, such as the use of stand-off fittings and the insertion of fire-resistant layers.

The LPS designer should identify all corrosion problem areas and specify appropriate measures to be taken.

The corrosion effects on the LPS may be reduced either by increases in material size, using corrosion-resistant components or by taking other corrosion protection measures.

E.5.6.2 Selection of materials

E.5.6.2.1 Materials

LPS materials and conditions of use are listed in Table 5 and the EN 50164 series.

Dimensions of LPS conductors, including air-termination conductors, down-conductors and earth-termination conductors, for different materials such as copper, aluminium and steel are given in Tables 6 and 7. The recommended values for copper and aluminium of 50 mm^2 round are based on the mechanical requirements (e.g. keep the wires straight between supports, so they don't sag to the roof). If mechanical constraints are of no concern the values from footnote b) of Table 6 (copper 28 mm^2) may be used as minimum values.

Minimum thickness of metal sheets, metal pipes and containers used as natural air-termination components are listed in Table 3, and minimum dimensions for bonding conductors are given in Tables 8 and 9.

E.5.6.2.2 Protection against corrosion

The LPS should be constructed of corrosion-resistant materials such as copper, aluminium, stainless steel and galvanized steel. The material of the air-termination rods and air-termination wires should be electrochemically compatible with the material of the connection elements and the mounting elements, and it should have a good corrosion resistance to a corrosive atmosphere or moisture.

Connections between different materials should be avoided; otherwise they are to be protected.

Copper parts should never be installed above galvanized or aluminium parts unless those parts are provided with protection against corrosion.

Extremely fine particles are shed by copper parts which result in severe corrosive damage to galvanized parts even where the copper and galvanized parts are not in direct contact.

Aluminium conductors should not be directly attached to calcareous building surfaces such as concrete limestone and plaster, and should never be used in soil.

E.5.6.2.2.1 Metals in soil and air

Corrosion of metal will occur at a rate depending on the type of metal and the nature of its environment. Environmental factors such as moisture, dissolved salts (thus forming an electrolyte), degree of aeration, temperature and extent of movement of electrolyte combine to make this condition a very complex one.

In addition, local conditions, with different natural or industrial contaminants, can cause significant variations to be observed in different parts of the world. To resolve particular corrosion problems, consultation with corrosion specialists is strongly recommended.

The effect of contact between dissimilar metals, in association with a surrounding, or partially surrounding, electrolyte, will lead to increased corrosion of the more anodic metal, and to decreased corrosion of the more cathodic metal.

The corrosion of the more cathodic metal will not necessarily be fully prevented. The electrolyte for this reaction may be groundwater, soil with some moisture content or even moisture condensate in above-ground structures where it is retained by crevices.

Extended earthing systems may suffer from different ground conditions in different parts. This can enhance the corrosion problems and requires special attention.

In order to minimize corrosion in an LPS:

- avoid the use of unsuitable metals in an aggressive environment;
- avoid contact of dissimilar metals, of substantially differing electrochemical or galvanic activity;
- use an adequate cross-section of conductors, bonding straps and conducting terminals and clamps to ensure sufficient corrosion life for the conditions of service;
- provide appropriate filling or isolating material in conductor joints which have not been welded conductor joints, so as to exclude moisture;
- provide a sleeve or a coat or isolate metals sensitive to corrosive fumes or fluids in the location of the installation;
- consider the galvanic effects of other metallic items to which the earth electrode is to be bonded;

- avoid designs where natural corrosion products from a cathodic metal (e.g. copper) could contact and erode the LPS, such as metallic copper on an anodic metal (e.g. steel or aluminium).

To conform to the foregoing, the following precautions are cited as specific examples:

- the minimum thickness or diameter of a strand should be 1,7 mm for steel, aluminium, copper, cuprous alloy or nickel/chrome/steel alloys;
- an isolating spacer is recommended where contact between closely spaced (or touching) dissimilar metals could cause corrosion, but such contact is not electrically necessary;
- steel conductors not otherwise protected should be hot-dipped galvanized in accordance with the requirements of Tables 6 and 7;
- aluminium conductors should not be buried directly in the ground nor set in or attached directly to concrete, unless they are completely sleeved with a durable, close-fitting isolating sleeve;
- copper/aluminium joints should be avoided wherever possible. In cases where they cannot be avoided, the connections should be welded or made employing an intermediate layer of copper/aluminium sheet;
- fasteners or sleeves for aluminium conductors should be of similar metal and of adequate cross-section to avoid failure by adverse weather conditions;
- copper is suitable for use in most earth electrode applications, except for acid, oxygenated ammoniac or sulphurous conditions. However, it should be remembered that it will cause galvanic damage to ferrous materials to which it is bonded. This may require specialist corrosion advice, particularly when a cathodic protection scheme is used;
- for roof conductors and down-conductors exposed to aggressive flue gases, particular attention should be paid to corrosion e.g. through the use of high-alloy steels (>16,5 % Cr, >2 % Mo, 0,2 % Ti, 0,12 % to 0,22 % N);
- stainless steel or other nickel alloys may be used for the same corrosion resistance requirements. However, in anaerobic conditions, such as clay, they will corrode almost as quickly as mild steel;
- joints between steel and copper or copper alloys in air, if not welded, should be either fully tin plated or fully coated with a durable moisture-resistant coating;
- copper and copper alloys are subject to stress corrosion cracking in ammoniac fumes and these materials should not be used for fastenings in these specific applications;
- in marine/coastal areas, all conductor joints should be welded or effectively fully sealed.

Stainless steel or copper earthing systems can be connected directly to the steel reinforcement in concrete.

Galvanized steel earth electrodes in soil should be connected to the steel reinforcement in concrete by isolating spark gaps capable of conducting a substantial part of the lightning current (see Tables 8 and 9 for the dimension of connecting conductors). A direct connection in the soil would significantly increase the risk of corrosion. Isolating spark gaps used should conform to 6.2.

NOTE Isolating spark gaps having a protection level U_p of 2,5 kV and a minimum I_{imp} of 50 kA (10/350 μ s) complying with EN 50164-3 are suitable.

Galvanized steel should be used for earth electrodes in soil only when no steel parts incorporated in the concrete are directly connected to the earth electrode in soil.

If metal pipes are put in soil and are connected to the equipotential bonding system and to the earth-termination system, the material of the pipes, where these are not isolated, and the material of the conductors of the earth system should be identical. Pipes with a protective covering of paint or asphalt are treated as if they are not isolated. When use of the same material is not possible, the pipework system should be isolated from the plant sections connected to the equipotential bonding system by means of isolated sections. The isolated

sections should be bridged by means of spark gaps. Bridging by spark gaps should also be performed where isolated pieces are installed for cathodic protection of pipework.

Conductors with lead sheaths should not be directly installed in concrete. Conductors with lead sheaths should be protected against corrosion by provision of either anti-corrosion bindings or by means of shrunk-on sleeving. Conductors may be protected by a PVC or PE covering.

Steel earth-termination conductors coming from concrete or from soil at the entry point to the air should be protected against corrosion for a length of 0,3 m by means of anti-corrosion wrappings or shrunk-on sleeving. For copper or stainless steel conductors this is not necessary.

The materials used for the joints between conductors in the soil should have identical corrosion behaviour to that of the earth-termination conductors. Connection by clamping is not generally permissible except in cases where such connections are provided with effective corrosion protection after making the joint. Good experience has been gained with crimped joints.

Welded joints shall be protected against corrosion.

Practical experience shows that

- aluminium should never be used as an earth electrode,
- lead-sheathed steel conductors are not suitable for use as earth conductors,
- lead-sheathed copper conductors should not be used in concrete nor in soil with a high calcium content.

E.5.6.2.2.2 Metals in concrete

The embedding of steel or galvanized steel in concrete causes a stabilization of the natural potential of the metal, due to the uniformly alkaline environment. In addition, the concrete is of uniformly, relatively high resistivity – of the order of 200 Ωm or higher.

Consequently, the reinforcing bars in concrete are considerably more resistant to corrosion than when they are exposed, even if connected externally to more cathodic-electrode materials.

The use of reinforcing steel as down-conductors does not pose any significant corrosion problems provided the access points for air-terminations are well encapsulated, e.g. by epoxy resin putty of adequate thickness.

Galvanized steel strips as foundation earth electrodes may be installed in concrete and directly connected to the steel reinforcing rods. Copper and stainless steel in concrete are also accepted and may be connected to the reinforcement steel directly.

Due to the natural potential of steel in concrete, additional earth electrodes outside the concrete should be made of copper or stainless steel.

In steel fibre reinforced concrete, if it is not possible to ensure the circumfusion of concrete thickness at least 50 mm over casting earth electrodes, the use of steel earth electrodes is not permitted because during the building process the steel electrode can be pressed down, for instance by the machines used, and touch the soil. In such a case, the steel faces a serious corrosion risk. Copper and stainless steel are suitable materials for earth electrodes in steel fibre concrete.

E.6 Internal lightning protection system

E.6.1 General

The requirements for the design of the internal lightning protection system are given in Clause 6.

The external lightning protection system and its relationship to conductive parts and installations inside the structure will determine, to a large extent, the need for an internal lightning protection system.

Consultation with all authorities and parties concerned with equipotential bonding is essential.

The LPS designer and LPS installer should draw attention to the fact that the measures given in Clause E.6 are very important in order to achieve adequate lightning protection. The purchaser should be notified accordingly.

The internal lightning protection is the same for all protection levels except for the separation distances.

The measures necessary for internal lightning protection exceed the equipotentialization measures for AC power systems in many cases because of the high current rate and current rise time occurring in the case of a lightning strike.

NOTE If protection against LEMP is to be considered, EN 62305-4 should be taken into account.

E.6.2 Lightning equipotential bonding (EB)

E.6.2.1 General

In the case of an isolated external LPS, the equipotential bonding is established only at ground level.

In the case of industrial structures, electrically-continuous conductive parts of the structure and the roof may be generally used as natural LPS components and may be used in the performance of equipotential bonding.

It is not only the conductive parts of the structure, and the equipment installed therein, that should be connected to the equipotential bonding but also the conductors of the power supply system and the communication equipment. For earth electrodes inside the structure, special care should be taken to control step voltages. Adequate measures include connecting concrete reinforcement steel to the earth electrodes locally or providing an equipotentialization mesh in the cellar or basement.

For buildings higher than 30 m, it is recommended to repeat the equipotential bonding at a level of 20 m and every 20 m above that. The separation requirements will generally be fulfilled.

This means that, at the very least, on those levels the external down-conductors, the internal down-conductors and metal parts should be bonded. Live conductors should be bonded via SPDs.

E.6.2.1.1 Bonding conductors

Bonding conductors should be able to withstand the part of the lightning current flowing through them.

Conductors bonding metal installations internal to the structure normally do not carry a significant part of the lightning current. Their minimum dimensions are given in Table 9.

Conductors bonding external conductive parts to the LPS usually carry a substantial part of the lightning current. Their minimum dimensions are given in Table 8.

E.6.2.1.2 Surge protective devices

Surge protective devices (SPDs) should withstand the prospective part of the lightning current flowing through them without being damaged. An SPD should also have the ability to extinguish electrical power follow-on currents from the power supply if they are connected to the electrical power conductors.

The selection of an SPD shall be performed according to 6.2. Where protection of internal systems against LEMP is required, SPDs shall also conform to **EN 62305-4**.

E.6.2.2 Equipotential bonding of internal conductive parts

Bonding should be provided and installed in such a way that the internal conductive parts, the external conductive parts and the electrical power and communication systems (for example computers and security systems) can be bonded by short bonding conductors. Internal and external conductive parts that have no electrical function should be bonded directly. All electrical connections (power and signal) should be bonded by means of SPDs.

Metal installations, i.e. water, gas, heating and air pipes, lift shafts, crane supports etc. shall be bonded together and to the LPS at ground level.

Sparking can occur in metal parts not belonging to the structure if those parts are close to the down-conductors of the LPS. Where this is considered dangerous, adequate bonding measures according to 6.2 should be used to prevent sparking.

A bonding bar arrangement is shown in Figure E.43.

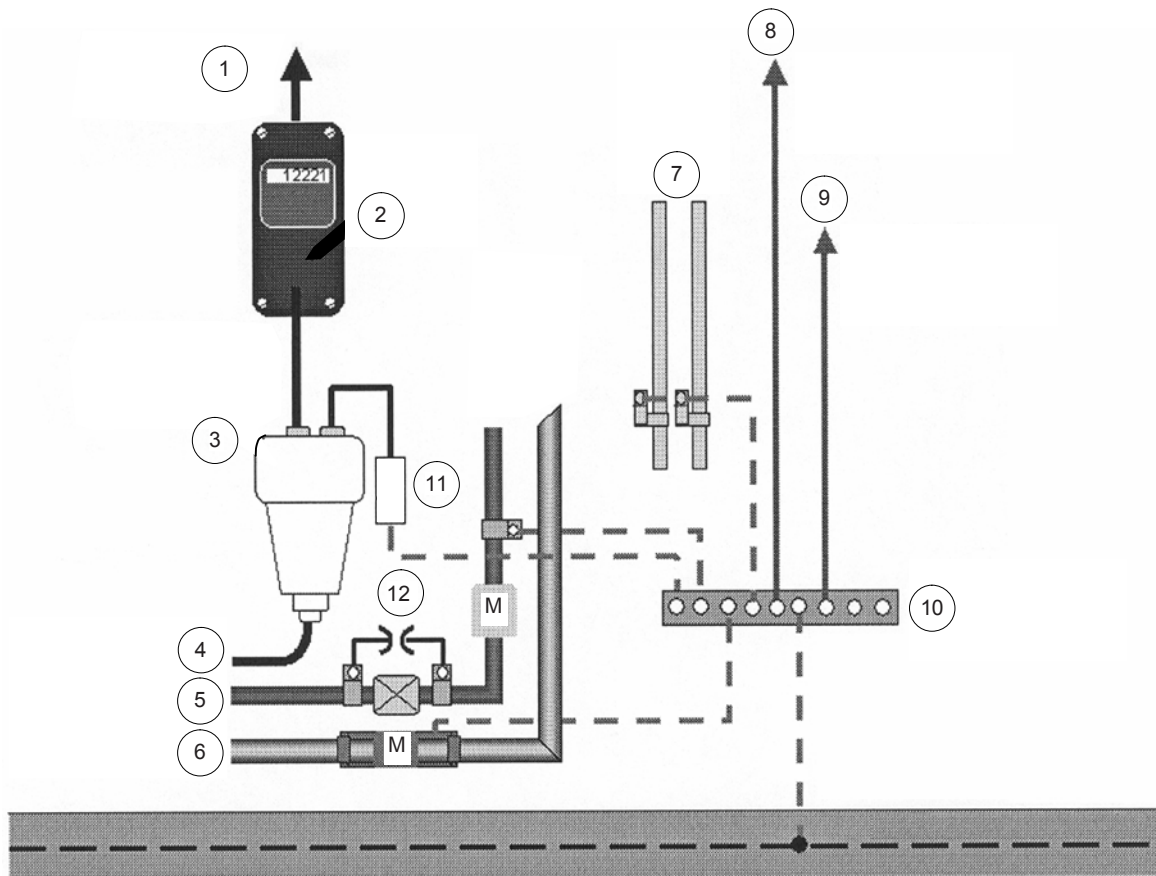

IEC 2731/10

Key

- 1 power to user
- 2 power meter
- 3 house connection box
- 4 power from utility
- 5 gas
- 6 water
- 7 central heating system
- 8 electronic appliances
- 9 screen of antenna cable
- 10 equipotential bonding bar
- 11 SPD
- 12 ISG
- M meter

Figure E.43 – Example of an equipotential bonding arrangement

The bonding bars should be located so that they are connected to the earth-termination system or to the horizontal ring conductors with short conductors.

The bonding bar is preferably installed at the inner side of an outer wall near ground level, close to the main low-voltage power distribution box and closely connected to the earth-termination system comprising the ring earth electrode, the foundation earth electrode and the natural earth electrode such as the interconnected reinforcing steel, where applicable.

In extended buildings, several bonding bars may be used provided that they are interconnected. Very long connections can form big loops leading to large induced currents and voltages. To minimize these effects, a meshed interconnection of those connections, the structure and the earthing system according to [C] EN 62305-4 [C] should be considered.

In reinforced concrete structures conforming to 4.3, the reinforcement may be used for equipotential bonding. In this case, an additional meshed network of welded or bolted terminal joints, described in E.4.3, should be installed in the walls, to which the bonding bars should be connected via welded conductors.

NOTE In this case, keeping a separation distance is not necessary.

The minimum cross-sections for a bonding conductor or a bonding connector are given in Tables 8 and 9. All internal conductive parts of significant size, such as elevator rails, cranes, metal floors, pipes and electrical services, should be bonded to the nearest bonding bar by a short bonding conductor at ground level and at other levels if the separation distance according to 6.3 cannot be maintained. Bonding bars and other bonding parts should withstand the prospective lightning currents.

In structures with reinforced walls only a minor fraction of the total lightning current is expected to flow through the bonding parts.

Figures E.44, E.45 and E.46 illustrate bonding arrangements in structures with multiple-point entries of external services.

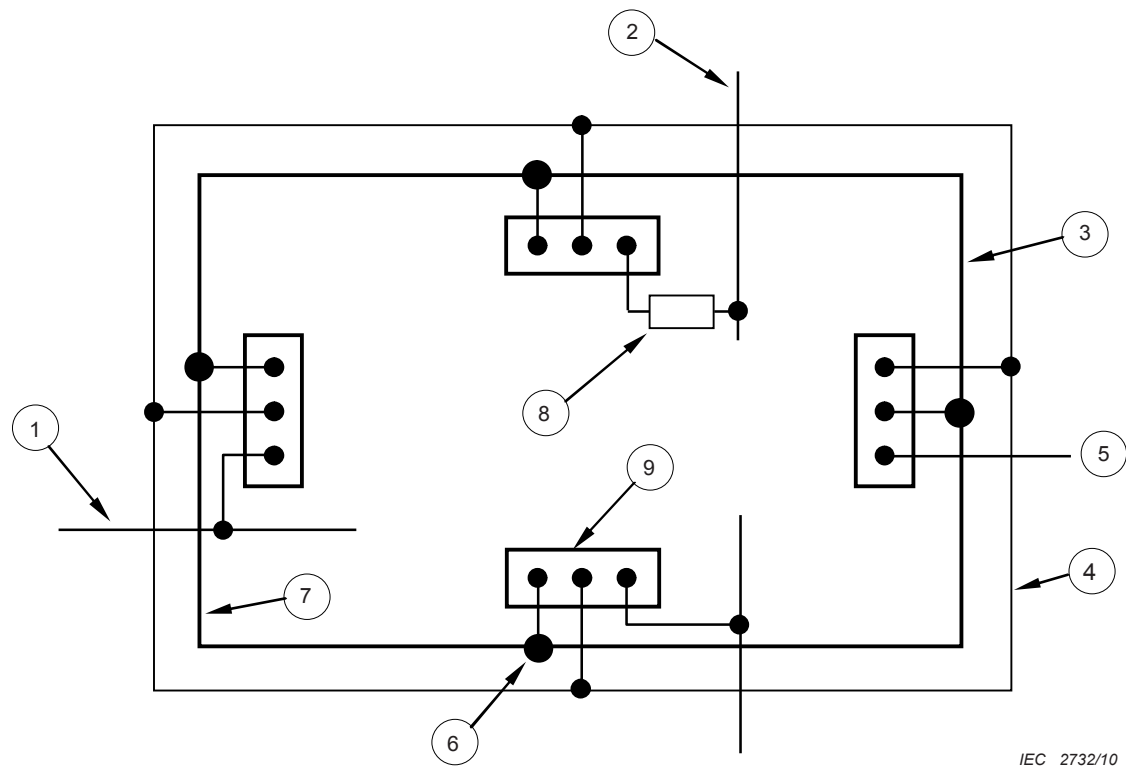

IEC 2732/10

Key

- 1 external conductive part, e.g. metallic water pipe
- 2 electric power or communication line
- 3 steel reinforcement of the outer concrete wall and the foundation
- 4 ring earthing electrode
- 5 to an additional earthing electrode
- 6 special bonding joint
- 7 steel-reinforced concrete wall, see Key, 3
- 8 SPD
- 9 bonding bar

NOTE The steel reinforcement in the foundation is used as a natural earth electrode.

Figure E.44 – Example of bonding arrangement in a structure with multiple point entries of external conductive parts using a ring electrode for interconnection of bonding bars

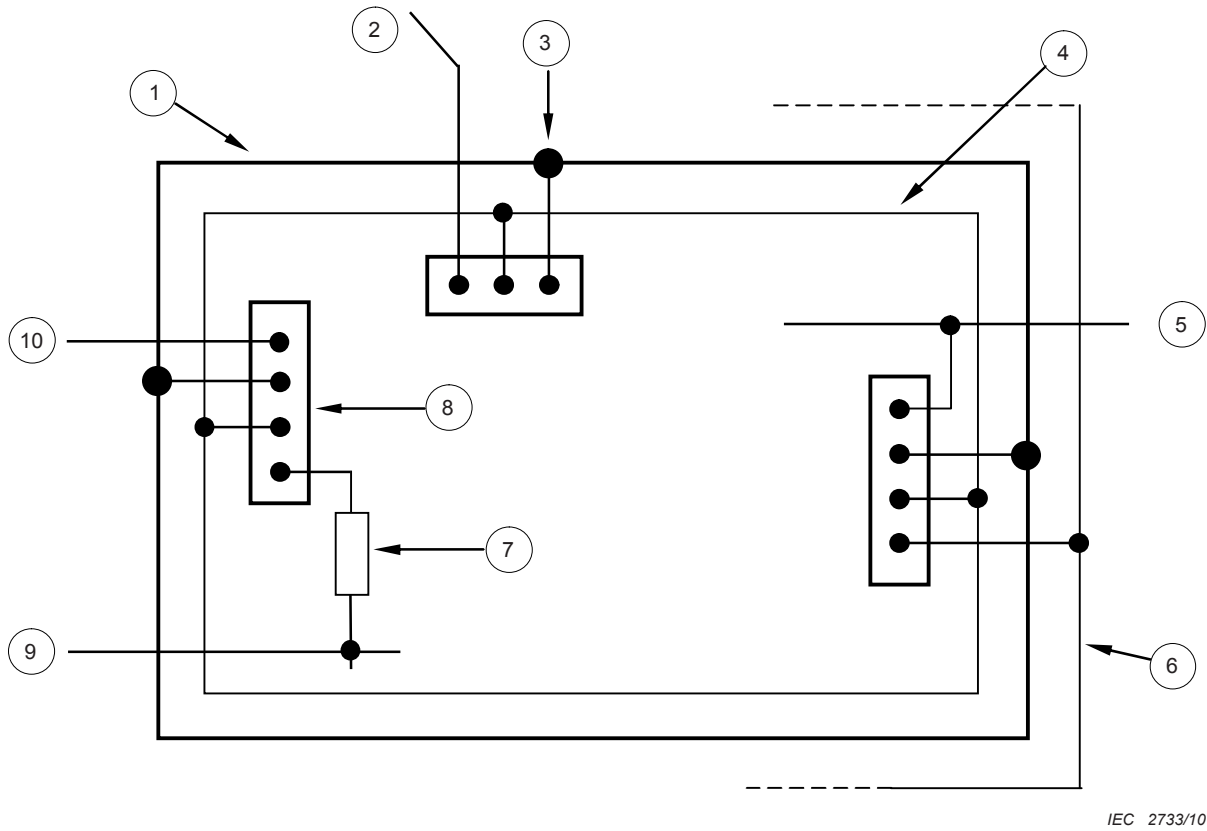

Key

- 1 steel reinforcement of the outer concrete wall and foundation
- 2 other earthing electrode
- 3 bonding joint
- 4 internal ring conductor
- 5 to external conductive part, e.g. water pipe
- 6 ring earthing electrode, type B earthing arrangement
- 7 SPD
- 8 bonding bar
- 9 electric power or communication line
- 10 to additional earthing electrode, type A earthing arrangement

Figure E.45 – Example of bonding in the case of multiple point entries of external conductive parts and an electric power or communication line using an internal ring conductor for interconnection of the bonding bars

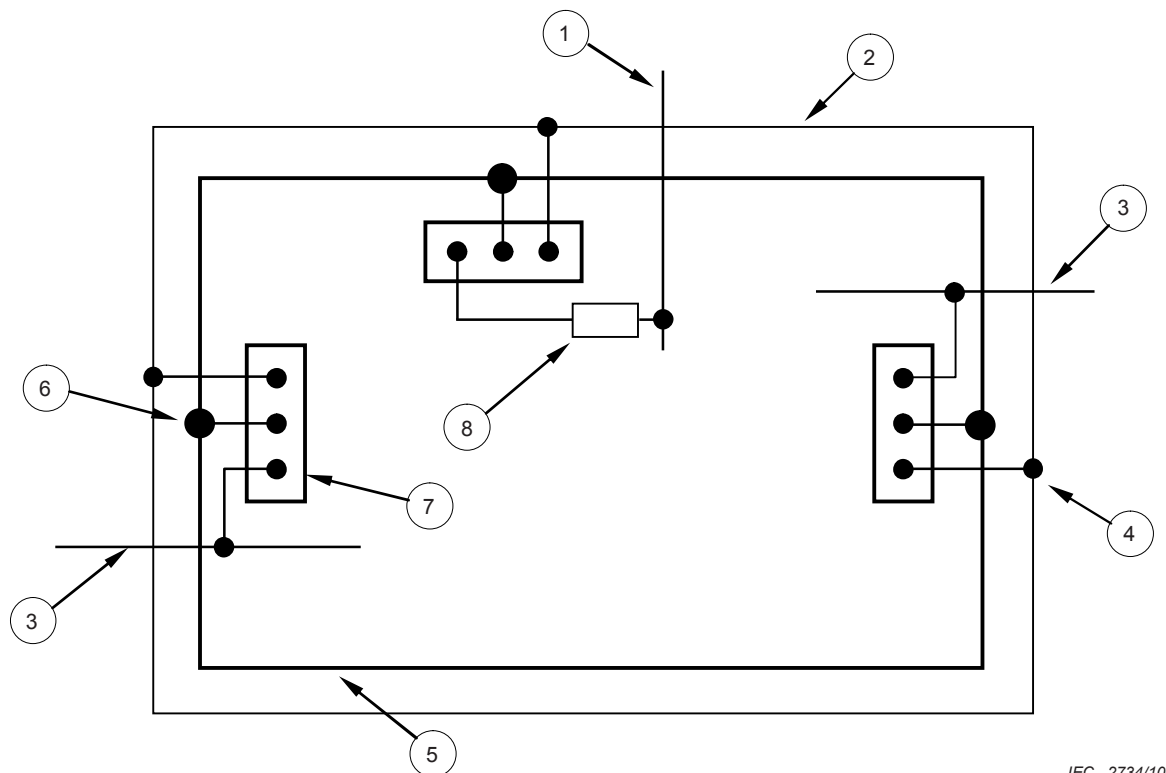

Key

- 1 electric power or communication line
- 2 external horizontal ring conductor (above ground)
- 3 external conductive part
- 4 down-conductor joint
- 5 steel reinforcement in the wall
- 6 bonding joint to construction steel
- 7 bonding bar
- 8 SPD

Figure E.46 – Example of bonding arrangement in a structure with multiple point entries of external conductive parts entering the structure above ground level

E.6.2.3 Lightning equipotential bonding for external conductive parts

No additional information available.

E.6.2.4 Lightning equipotential bonding for electrical and electronic systems within the structure to be protected

Details for lightning equipotential bonding for internal systems are given in [EN 62305-4](#).

E.6.2.5 Equipotential bonding of external services

Preferably, the external conductive parts and the electrical power and communication lines should enter the structure near ground level at a common location.

Equipotential bonding should be performed as close as possible to the entry point into the building. In the case of a low-voltage power supply, this is immediately downstream of the service entrance box (subject to approval of the local power company).

The bonding bar at this common location of entry should be connected with short bonding conductors to the earth-termination system.

If the services entering the building are shielded lines, the shields shall be connected to the bonding bar. The overvoltage reaching the active conductors is a function of the size of the partial lightning current over the screen (i.e. according to Annex B) and the cross-section of the shield. Annex E of [C]EN 62305-1:2010 [C] provides a method to estimate this current. SPDs are necessary if the expected overvoltages exceed the specification of the line and connected objects.

If the services entering the building are not shielded, the partial lightning current will flow on the active conductors. In this case, SPDs with lightning current capabilities should be placed at the entry point. PE or PEN conductors may be connected to the bonding bar directly.

When the external conductive parts, the electrical power and communication lines have to enter the structure at different locations, and therefore need several bonding bars to be installed, the bonding bars should be connected as closely as possible to the earth-termination system, i.e. the ring earth electrode, to the reinforcement of the structure and to the foundation earth electrode of the structure, if applicable.

When a type A earthing arrangement is utilized as a part of the LPS, the bonding bars should be connected to individual earth electrodes and, in addition, they should be interconnected by an internal ring conductor or an internal conductor forming a partial ring.

For entries of external services above the earth surface, the bonding bars should be connected to a horizontal ring conductor inside or outside the outer wall bonded to the down-conductors of the LPS and to the metallic reinforcement of the structure, if applicable.

The ring conductor should be connected to the steel reinforcement, and other metallic elements of the structure, at regular subdivisions of the distance between the down-conductors as stated in Table 4, typically every 5 m to 10 m.

In buildings principally designed for computer centres, communication buildings and other structures requiring a low level of LEMP induction effects, the ring conductor should be connected to the reinforcement typically every 5 m.

For the bonding of external services in reinforced concrete buildings which contain large communication or computer installations, and for structures where EMC demands are severe, a ground plane with multiple connections to the metallic reinforcement of the structure or other metallic elements should be used.

E.6.3 Electrical isolation of the external LPS

E.6.3.1 General

An adequate separation distance, determined according to 6.3, should be maintained between the external LPS and all conductive parts connected to the equipotential bonding of the structure.

The separation distance may be evaluated by Equation (4) shown in 6.3.

The reference length, l , for the calculation of the separation distance s (see 6.3), should be the distance between the connection to the nearest equipotential bonding point or earth-termination network and the point of proximity along the down-conductor. The roof and down-conductors should follow a route as straight as possible to keep the necessary separation distance low.

The length and the path of the conductor within the building running from bonding bar to point of proximity is generally of little influence on the separation distance, but when this conductor runs close to a lightning current-carrying conductor the necessary separation distance will be lower. Figure E.47 illustrates how the critical length, l , used for calculation of the separation distance, s , according to 6.3, is measured on an LPS.

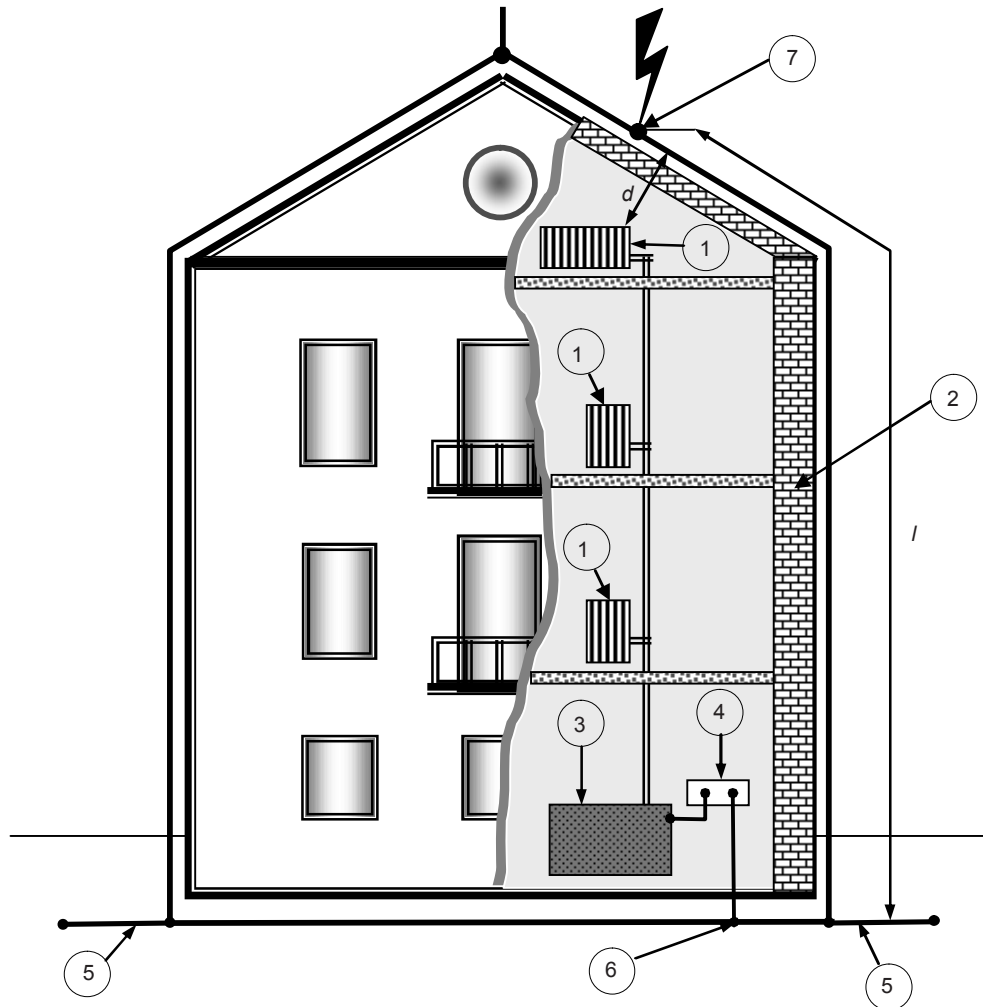

IEC 2735/10

Key

- 1 metallic radiator/heater
- 2 wall of brickwork or wood
- 3 heater
- 4 equipotential bonding bar
- 5 earth-termination system
- 6 connection to the earth-termination system or to the down-conductor
- 7 worst case
- d actual distance
- l length for evaluation of separation distance, s

NOTE The structure consists of insulating bricks.

Figure E.47 – Directions for calculations of the separation distance, s , for a worst case lightning interception point at a distance, l , from the reference point according to 6.3

In structures where the building components are used as natural down-conductors, for example steel reinforcement in concrete, the reference point should be the connection point to the natural down-conductor.

Structures with outer surfaces that do not contain conductive elements, such as structures of wood or brickwork, should use the shortest possible overall distance along the lightning protection conductors / from the most unfavourable lightning strike point to the nearest earth-termination or the point where the equipotential bonding system of the internal installation is connected to the down-conductor or the earth-termination system, for calculation of the separation distance, s , according to 6.3.

When it is not possible to maintain the distance greater than the separation distance s along the whole length of the considered installation, bonding of the installation to the LPS should also be performed at the furthest point from the reference bonding point (see Figure E.47). Therefore, the electrical conductors should either be re-routed in accordance with the requirements of the separation distance (see 6.3) or they should be enclosed in a conductive shield bonded to the LPS at the furthest point from the reference bonding point.

When bonding of installations to the LPS in buildings lower than 30 m is performed at the reference point and the furthest point, the separation distance is fulfilled along the whole path of the installation.

The following points are often critical and require particular consideration:

- In the case of larger structures, the separation distance between the LPS conductors and the metal installations is often so large that it cannot be implemented. This involves additional bonding of the LPS to these metal installations. Consequently, a portion of the lightning current flows via these metal installations to the earth-termination system of the structure.
- Electromagnetic interference occurring as a result of these partial currents should be taken into account when planning the structure installations and designing the lightning protection electromagnetic zones inside the structure according to [EN 62305-4](#).

However, the interference will be significantly lower than that caused by an electrical spark at this point.

In the case of roofs, the distance between the LPS and the electrical installations is often found to be shorter than the separation distance, s , given in 6.3. If this is the case, an attempt should be made to install the LPS or the electrical conductor at a different location.

An agreement should be reached with the person responsible for the electrical installation to perform a re-routing of electrical circuits which do not conform to the separation distance to the air-termination conductors on structures.

When the electrical installation cannot be re-routed, bonding to the external LPS should be carried out in accordance with 6.3.

In some buildings it is not possible to maintain the separation distances as required. Internal constructions can prevent the designer or installer from assessing situations and making connections to certain metal parts and electrical conductors. This should be communicated to the owner of the building.

E.6.3.2 Simplified approach

The simplified approach according to 6.3.2 is possible, if the widest horizontal elongation of the structure (length or width) does not exceed four times the height.

E.6.4 Protection against effects of induced currents in internal systems

Currents in the conductors of the external LPS may induce excessive over-voltages in the conductor loops of the internal installations by the effect of magnetic coupling. Overvoltages may cause failures of internal systems.

Since practically all buildings contain electronic equipment, the effect of the electromagnetic field of the external and internal down-conductors should be taken into account in the planning of the lightning protection system.

Protection measures against overvoltages are given in **EN 62305-4**.

E.7 Maintenance and inspection of the LPS

E.7.1 Scope of inspections

Inspection of the LPS should be conducted by a lightning protection specialist in accordance with the recommendations of Clause E.7.

The inspector should be provided with the LPS design report containing the necessary documentation of the LPS such as design criteria, design description and technical drawings. The LPS inspector should also be provided with previous LPS maintenance and inspection reports.

All LPS should be inspected on the following occasions:

- during installation of the LPS, especially during installation of components which are concealed in the structure and will become inaccessible;
- after the completion of the LPS installation;
- on a regular basis according to Table E.2.

Table E.2 – Maximum period between inspections of an LPS

Protection level	Visual inspection year	Complete inspection year	Critical situations^{a b} complete inspection year
I and II	1	2	1
III and IV	2	4	1

^a Lightning protection systems utilized in applications involving structures with a risk caused by explosive materials should be visually inspected every 6 months. Electrical testing of the installation should be performed once a year. An acceptable exception to the yearly test schedule would be to perform the tests on a 14 to 15 month cycle where it is considered beneficial to conduct earth resistance testing over different times of the year to get an indication of seasonal variations.

^b Critical situations could include structures containing sensitive internal systems, office blocks, commercial buildings or places where a high number of people may be present.

The inspection frequencies given in Table E.2 should apply where no specific requirements are identified by the authority having jurisdiction.

NOTE If national authorities or institutions require regular tests of the electrical system of a structure, it is recommended to test the lightning protection system with regard to the functioning of the Internal lightning protection measures including the lightning protection equipotential bonding with electric systems at the same time. Older installations analogously should be related to a lightning protection class or the test intervals should be taken from the local or any other test specifications such as construction guide lines, technical regulations, instructions, industrial safety and protection of labour laws.

The LPS should be visually inspected at least annually. In some areas where severe weather changes and extreme weather conditions occur, it is advisable to visually inspect the system more often than indicated in Table E.2. Where the LPS forms part of the client's planned maintenance programme, or is a requirement of the building insurers, the LPS may be required to be fully tested annually.

The interval between the LPS inspections should be determined by the following factors:

- classification of structure protected, especially with regard to the consequential effects of damage;
- class of LPS;
- local environment, for example a corrosive atmosphere environment should have short intervals between inspections;
- the materials of the individual LPS components;
- the type of surface to which the LPS components are attached;
- the soil condition and associated corrosion rates.

In addition to the above, an LPS should be inspected whenever any significant alteration or repairs are made to a protected structure and also following any known lightning discharge to the LPS.

A total inspection and test should be completed every two to four years. Systems in critical environmental conditions, for example parts of the LPS exposed to severe mechanical stresses such as flexible bonding straps in high wind areas, SPDs on pipelines, outdoor bonding of cables etc., should have a complete inspection every year.

In most geographical areas, and especially in areas which experience extreme seasonal changes in temperature and rainfall, the variation of the earthing resistance should be taken into account by measuring the resistivity depth profile in different weather periods.

An improvement of the earthing system should be considered when the measured resistance values show larger changes in the resistance than anticipated in the design; especially when the resistance increases steadily between inspections.

E.7.2 Order of inspections

E.7.2.1 Inspection procedure

The purpose of this inspection is to ensure that the LPS conforms to this standard in all respects.

The inspection includes checking technical documentation, visual inspections, testing and logging in an inspection report.

E.7.2.2 Checking of technical documentation

Technical documentation should be checked for completeness, conformity to this standard and agreement with the plant as executed.

E.7.2.3 Visual inspections

Visual inspections should be made to ascertain that

- the design conforms to this standard,
- the LPS is in good condition,
- there are no loose connections and no accidental breaks in the LPS conductors and joints,
- no part of the system has been weakened by corrosion, especially at ground level,
- all visible earth connections are intact (functionally operational),
- all visible conductors and system components are fastened to the mounting surfaces and components which provide mechanical protection are intact (functionally operational) and in the right place,
- there have not been any additions or alterations to the protected structure which would require additional protection,

- there has been no indication of damage to the LPS, to SPDs or any failures of fuses which protect SPDs,
- correct equipotential bonding has been established for any new services or additions which have been made to the interior of the structure since the last inspection, and that continuity tests have been performed for these new additions,
- bonding conductors and connections inside the structure are present and intact (functionally operational),
- separation distances are maintained,
- bonding conductors, joints, shielding devices, cable routing and SPDs have been checked and tested.

E.7.2.4 Testing

Inspection and testing of the LPS includes visual inspections and should be completed by the following actions:

- performing continuity tests, especially continuity of those parts of the LPS which were not visible for inspection during the initial installation and are not subsequently available for visual inspection;
- conducting earth resistance tests of the earth-termination system. The following isolated and combined earth measurements and checks should be made and the results recorded in an LPS inspection report.

NOTE 1 High-frequency or impulse measurements are possible and useful to determine the high frequency or impulse behaviour of the earth-termination system. These measurements may be performed at the installation stage as well as periodically for the maintenance of the earthing system to check adequacy between the designed earthing system and the need.

- a) The resistance to earth of each local earth electrode and where reasonably practical the resistance to earth of the complete earth-termination system.

Each local earth electrode should be measured in isolation with the test joint between the down-conductor and earth electrode in the disconnected position (isolated measurement).

NOTE 2 For earth networks incorporating both vertical earth rods and a partial or full ring earth electrode, disconnection and testing should be performed at the earth inspection pit. If such inspection is difficult to perform, routine test should be completed by high frequency or impulse tests.

If the resistance to earth of the earth-termination system as a whole exceeds 10 Ω , a check should be made to ascertain that the electrode conforms to Figure 3.

If there is a significant increase or decrease in the value of the earth resistance, additional investigations should be made to determine the reason for the change.

For earth electrodes in rocky soil, the requirements of E.5.4.3.5 should be followed. The 10 Ω requirement is not applicable in this case.

- b) The results of a visual check of all conductors, bonds and joints or their measured electrical continuity.

If the earth-termination system does not conform to these requirements, or checking the requirements is not possible because of a lack of information, the earth-termination system should be improved by installing extra earth electrodes or installing a new earth-termination system.

SPDs without a visual indicator need to be tested, preferably using the guidelines or equipment provided by the manufacturer.

E.7.2.5 Documentation of inspection

LPS inspection guides should be prepared to facilitate LPS inspections. They should contain sufficient information to guide the inspector through the inspection process so that all areas of

importance are documented such as the method of LPS installation, the type and condition of the LPS components, test methods and the proper recording of the test data obtained.

The inspector should compile an LPS inspection report, which should be kept together with the LPS design report and the previously compiled LPS maintenance and inspection reports.

The LPS inspection report should contain the following information:

- general conditions of air-termination conductors, and other air-termination components;
- general level of corrosion and the condition of the corrosion protection;
- security of attachment of the LPS conductors and components;
- earth resistance measurements of the earth-termination system;
- any deviation from the requirements of this standard;
- documentation of all changes and extension of the LPS and any changes to the structure. In addition, the LPS construction drawings and the LPS design description should be reviewed;
- the results of the tests performed.

E.7.3 Maintenance

The LPS should be maintained regularly to ensure that it does not deteriorate but continues to fulfil the requirements to which it was originally designed. The design of an LPS should determine the necessary maintenance and inspection cycle according to Table E.2.

The LPS maintenance programme should ensure a continuous updating of the LPS to the current issue of this standard.

E.7.3.1 General remarks

LPS components tend to lose their effectiveness over the years because of corrosion, weather-related damage, mechanical damage and damage from lightning strokes.

The inspection and maintenance programmes should be specified by an authority, the LPS designer or the LPS installer, in conjunction with the owner of the structure or an appointed representative.

To carry out maintenance work and to perform inspections of an LPS the two programmes, inspection and maintenance, should be coordinated.

Maintenance of an LPS is important even though the LPS designer has taken special precautions to provide corrosion protection and has dimensioned the LPS components according to their particular exposure to lightning damage and weather elements in addition to the requirements of this standard.

The mechanical and electrical characteristics of the LPS should be fully maintained throughout the entire lifetime of the LPS in order to conform to the design requirements of this standard.

It may be necessary to modify the LPS if modifications are carried out on the building or its equipment or if the purpose for which the building is utilized is altered.

If an inspection shows that repairs are necessary, those repairs should be executed without delay and not be postponed until the next maintenance cycle.

E.7.3.2 Maintenance procedure

Periodic maintenance programmes should be established for all LPS.

The frequency of maintenance procedures is dependent on the following:

- weather- and environment-related degradation;
- exposure to actual lightning damage;
- protection level assigned to the structure.

LPS maintenance procedures should be established for each particular LPS and should become a part of the overall maintenance programme for the structure.

A maintenance programme should contain a list of routine items to serve as a checklist so that definite maintenance procedures are followed regularly in order to make it possible to compare recent results with previous ones.

A maintenance programme should contain provisions for the following:

- verification of all LPS conductors and system components;
- verification of the electrical continuity of the LPS installation;
- measurement of the resistance to earth of the earth-termination system;
- verification of SPDs;
- re-fastening of components and conductors;
- verification to ensure the effectiveness of the LPS has not been reduced after additions to, or changes in, the structure and its installations.

E.7.3.3 Maintenance documentation

Complete records should be kept of all maintenance procedures and should include corrective actions taken or required.

Maintenance procedure records should provide a means of evaluating LPS components and the LPS installation.

The LPS maintenance record should serve as a basis for reviewing maintenance procedures as well as for updating maintenance programmes. The LPS maintenance records should be kept together with the LPS design and the LPS inspection reports.

Bibliography

- [1] NFPA(National Fire Protection Standards), 780:2008, *Standard for the Installation of Lightning Protection Systems*
 - [2] IEC 61400-24, *Wind turbines – Part 24: Lightning protection*
 - [3] IEC 60050-826:2004, *International Electrotechnical Vocabulary – Part 826: Electrical installations*
 - [4] IEC 60050-426:2008, *International Electrotechnical Vocabulary – Part 426: Equipment for explosive atmospheres*
 - [5] IEC/TR 61000-5-2, *Electromagnetic compatibility (EMC) – Part 5: Installation and mitigation guidelines – Section 2: Earthing and cabling*
 - [6] IEC 60728-11, *Cable networks for television signals, sound signals and interactive services – Part 11: Safety*
-

This page deliberately set blank

British Standards Institution (BSI)

BSI is the national body responsible for preparing British Standards and other standards-related publications, information and services.

BSI is incorporated by Royal Charter. British Standards and other standardization products are published by BSI Standards Limited.

About us

We bring together business, industry, government, consumers, innovators and others to shape their combined experience and expertise into standards-based solutions.

The knowledge embodied in our standards has been carefully assembled in a dependable format and refined through our open consultation process. Organizations of all sizes and across all sectors choose standards to help them achieve their goals.

Information on standards

We can provide you with the knowledge that your organization needs to succeed. Find out more about British Standards by visiting our website at bsigroup.com/standards or contacting our Customer Services team or Knowledge Centre.

Buying standards

You can buy and download PDF versions of BSI publications, including British and adopted European and international standards, through our website at bsigroup.com/shop, where hard copies can also be purchased.

If you need international and foreign standards from other Standards Development Organizations, hard copies can be ordered from our Customer Services team.

Subscriptions

Our range of subscription services are designed to make using standards easier for you. For further information on our subscription products go to bsigroup.com/subscriptions.

With **British Standards Online (BSOL)** you'll have instant access to over 55,000 British and adopted European and international standards from your desktop. It's available 24/7 and is refreshed daily so you'll always be up to date.

You can keep in touch with standards developments and receive substantial discounts on the purchase price of standards, both in single copy and subscription format, by becoming a **BSI Subscribing Member**.

PLUS is an updating service exclusive to BSI Subscribing Members. You will automatically receive the latest hard copy of your standards when they're revised or replaced.

To find out more about becoming a BSI Subscribing Member and the benefits of membership, please visit bsigroup.com/shop.

With a **Multi-User Network Licence (MUNL)** you are able to host standards publications on your intranet. Licences can cover as few or as many users as you wish. With updates supplied as soon as they're available, you can be sure your documentation is current. For further information, email bsmusales@bsigroup.com.

BSI Group Headquarters

389 Chiswick High Road London W4 4AL UK

Revisions

Our British Standards and other publications are updated by amendment or revision.

We continually improve the quality of our products and services to benefit your business. If you find an inaccuracy or ambiguity within a British Standard or other BSI publication please inform the Knowledge Centre.

Copyright

All the data, software and documentation set out in all British Standards and other BSI publications are the property of and copyrighted by BSI, or some person or entity that owns copyright in the information used (such as the international standardization bodies) and has formally licensed such information to BSI for commercial publication and use. Except as permitted under the Copyright, Designs and Patents Act 1988 no extract may be reproduced, stored in a retrieval system or transmitted in any form or by any means – electronic, photocopying, recording or otherwise – without prior written permission from BSI. Details and advice can be obtained from the Copyright & Licensing Department.

Useful Contacts:

Customer Services

Tel: +44 845 086 9001

Email (orders): orders@bsigroup.com

Email (enquiries): cservices@bsigroup.com

Subscriptions

Tel: +44 845 086 9001

Email: subscriptions@bsigroup.com

Knowledge Centre

Tel: +44 20 8996 7004

Email: knowledgecentre@bsigroup.com

Copyright & Licensing

Tel: +44 20 8996 7070

Email: copyright@bsigroup.com



...making excellence a habit.™