

BS EN 62216:2011



BSI Standards Publication

Digital terrestrial television receivers for the DVB-T system

NO COPYING WITHOUT BSI PERMISSION EXCEPT AS PERMITTED BY COPYRIGHT LAW

raising standards worldwide™



National foreword

This British Standard is the UK implementation of EN 62216:2011. It is identical to IEC 62216:2009. It supersedes BS EN 62216-1:2002 which is withdrawn.

The UK participation in its preparation was entrusted to Technical Committee EPL/100, Audio, video and multimedia systems and equipment.

A list of organizations represented on this committee can be obtained on request to its secretary.

This publication does not purport to include all the necessary provisions of a contract. Users are responsible for its correct application.

© BSI 2011

ISBN 978 0 580 64535 8

ICS 33.160.25

Compliance with a British Standard cannot confer immunity from legal obligations.

This British Standard was published under the authority of the Standards Policy and Strategy Committee on 31 July 2011.

Amendments issued since publication

Date

Text affected

English version

Digital terrestrial television receivers for the DVB-T system
(IEC 62216:2009)Récepteur de télévision numérique
terrestre pour le système DVB-T
(CEI 62216:2009)Fernsehempfänger für das digitale
terrestrische DVB-T-System
(IEC 62216:2009)

This European Standard was approved by CENELEC on 2011-01-02. CENELEC members are bound to comply with the CEN/CENELEC Internal Regulations which stipulate the conditions for giving this European Standard the status of a national standard without any alteration.

Up-to-date lists and bibliographical references concerning such national standards may be obtained on application to the Central Secretariat or to any CENELEC member.

This European Standard exists in three official versions (English, French, German). A version in any other language made by translation under the responsibility of a CENELEC member into its own language and notified to the Central Secretariat has the same status as the official versions.

CENELEC members are the national electrotechnical committees of Austria, Belgium, Bulgaria, Croatia, Cyprus, the Czech Republic, Denmark, Estonia, Finland, France, Germany, Greece, Hungary, Iceland, Ireland, Italy, Latvia, Lithuania, Luxembourg, Malta, the Netherlands, Norway, Poland, Portugal, Romania, Slovakia, Slovenia, Spain, Sweden, Switzerland and the United Kingdom.

CENELECEuropean Committee for Electrotechnical Standardization
Comité Européen de Normalisation Electrotechnique
Europäisches Komitee für Elektrotechnische Normung**Management Centre: Avenue Marnix 17, B - 1000 Brussels**

Foreword

The text of document 100/1449/CDV, future edition 1 of IEC 62216, prepared by technical area 1, Terminals for audio, video and data services and contents of IEC TC 100, Audio, video and multimedia systems and equipment, was submitted to the IEC-CENELEC parallel vote and was approved by CENELEC as EN 62216 on 2011-01-02.

This European Standard supersedes EN 62216-1:2002.

Attention is drawn to the possibility that some of the elements of this document may be the subject of patent rights. CEN and CENELEC shall not be held responsible for identifying any or all such patent rights.

The following dates were fixed:

- latest date by which the EN has to be implemented
at national level by publication of an identical
national standard or by endorsement (dop) 2011-10-02
- latest date by which the national standards conflicting
with the EN have to be withdrawn (dow) 2014-01-02

Annex ZA has been added by CENELEC.

Endorsement notice

The text of the International Standard IEC 62216:2009 was approved by CENELEC as a European Standard without any modification.

Annex ZA (normative)

Normative references to international publications with their corresponding European publications

The following referenced documents are indispensable for the application of this document. For dated references, only the edition cited applies. For undated references, the latest edition of the referenced document (including any amendments) applies.

NOTE When an international publication has been modified by common modifications, indicated by (mod), the relevant EN/HD applies.

| <u>Publication</u> | <u>Year</u> | <u>Title</u> | <u>EN/HD</u> | <u>Year</u> |
|--------------------|-------------|---|--------------|-------------|
| - | - | Domestic and similar electronic equipment interconnection requirements: Peritelevision connector | EN 50049-1 | - |
| - | - | Common interface specification for conditional access and other digital video broadcasting decoder applications | EN 50221 | - |
| IEC 60958-1 | - | Digital audio interface - Part 1: General | EN 60958-1 | - |
| IEC 61169-2 | - | Radio-frequency connectors - Part 2: Sectional specification - Radio frequency coaxial connectors of type 9,52 | EN 61169-2 | - |
| IEC 61937 | Series | Digital audio - Interface for non-linear PCM encoded audio bitstreams applying IEC 60958 | EN 61937 | Series |
| ISO/IEC 6937 | - | Information technology - Coded graphic character set for text communication - Latin alphabet | - | - |
| ISO/IEC 8859-9 | - | Information technology - 8-bit single-byte coded graphic character sets - Part 9: Latin alphabet No. 5 | - | - |
| ISO/IEC 11172-2 | - | Information technology - Coding of moving pictures and associated audio for digital storage media at up to about 1,5 Mbit/s - Part 2: Video | - | - |
| ISO/IEC 13818-1 | - | Information technology - Generic coding of moving pictures and associated audio information: Systems | - | - |
| ISO/IEC 13818-2 | - | Information technology - Generic coding of moving pictures and associated audio information - Part 2: Video | - | - |
| ISO/IEC 13818-3 | - | Information technology - Generic coding of moving pictures and associated audio information - Part 3: Audio | - | - |
| ISO/IEC 14496-3 | - | Information technology - Coding of audio-visual objects - Part 3: Audio | - | - |
| ISO/IEC 14496-10 | - | Information technology - Coding of audio-visual objects - Part 10: Advanced Video Coding | - | - |

| <u>Publication</u> | <u>Year</u> | <u>Title</u> | <u>EN/HD</u> | <u>Year</u> |
|--------------------|-------------|---|--------------|-------------|
| ISO 639-2 | - | Codes for the representation of names of languages - Part 2: Alpha-3 code | - | - |
| ETSI EN 300 744 | - | Digital Video Broadcasting (DVB): Framing structure, channel coding and modulation for digital terrestrial television | - | - |
| ETSI EN 300 468 | - | Digital Video Broadcasting (DVB): Specification for Service Information (SI) in DVB systems | - | - |
| ETS EN 300 743 | - | Digital Video Broadcasting (DVB) - Subtitling systems | - | - |
| ETSI EN 300 706 | - | Enhanced teletext specification | - | - |
| ETSI EN 300 472 | - | Digital Video Broadcasting (DVB) - Specification for conveying ITU-R system B teletext in DVB bitstreams | - | - |
| ETSI EN 300 294 | - | Television systems - 625 line television Wide Screen Signalling (WSS) | - | - |
| ETSI EN 301 775 | - | Digital Video Broadcasting (DVB) - Specification for the carriage of Vertical Blanking Information (VBI) data in DVB bitstreams | - | - |
| ETSI EN 300 231 | - | Television systems - Specification of the domestic video Programme Delivery Control system (PDC) | - | - |
| ETSI TS 101 154 | - | Digital Video Broadcasting (DVB); Specification for the use of Video and Audio Coding in Broadcasting Applications based on the MPEG-2 Transport Stream | - | - |
| ETSI TS 102 366 | - | Digital Audio Compression (AC-3, Enhanced AC-3) | - | - |
| ETSI TS 101 699 | - | Digital Video Broadcasting (DVB) - Extensions to the common interface specification | - | - |
| ETSI TR 101 211 | - | Digital Video Broadcasting (DVB); Guidelines on implementation and usage of Service Information (SI) | - | - |
| ETSI TS 102 006 | - | Digital Video Broadcasting (DVB); Specification for System Software Update in DVB Systems | - | - |
| ETR 289 | - | Digital Video Broadcasting (DVB) - Support for use of scrambling and Conditional Access (CA) within digital broadcasting systems | - | - |
| ETR 162 | - | Digital broadcasting systems for television sound and data services - Allocation of Service Information (SI) codes for Digital Video Broadcasting (DVB) systems | - | - |
| ITU-R BS.775-2 | - | Multichannel stereophonic sound system with and without accompanying picture | - | - |
| ITU-R BT.470-7 | - | Conventional analogue television systems | - | - |

| <u>Publication</u> | <u>Year</u> | <u>Title</u> | <u>EN/HD</u> | <u>Year</u> |
|--------------------|-------------|---|--------------|-------------|
| ITU-R BT.1119-2 | - | Wide-screen signalling for broadcasting (Signalling for wide-screen and other enhanced television parameters) | - | - |
| ITU-R BT.1359-1 | - | Relative timing of sound and vision for broadcasting | - | - |
| R 206-001 | - | Guidelines for implementation and use of the common interface for DVB decoder applications | - | - |
| CEA 770.3 | - | High definition TV analog component video interface | - | - |
| CEA 861 | - | A DTV Profile for Uncompressed High Speed Digital Interfaces | - | - |

CONTENTS

| | |
|---|----|
| FOREWORD..... | 8 |
| INTRODUCTION..... | 10 |
| 1 Scope and object..... | 11 |
| 2 Normative references | 11 |
| 3 Abbreviations and symbols..... | 13 |
| 4 Receiver capabilities | 15 |
| 4.1 Frequency spectrum..... | 15 |
| 4.2 Conditional access | 15 |
| 4.3 Return path | 15 |
| 4.4 EPG (SI) | 15 |
| 4.5 Auto installation..... | 16 |
| 4.6 Teletext carried in digital streams..... | 16 |
| 4.7 Content protection/copy management..... | 16 |
| 4.8 Services | 16 |
| 4.9 API..... | 16 |
| 4.10 Over-air software update | 16 |
| 4.11 Audio and video codecs | 16 |
| 4.12 Future versions of this standard | 17 |
| 5 Video system characteristics | 17 |
| 5.1 General..... | 17 |
| 5.2 Essential requirements | 17 |
| 5.2.1 Standard services..... | 17 |
| 5.2.2 Advanced services | 17 |
| 5.3 Constraints and extensions | 17 |
| 5.3.1 Support for rapid channel acquisition..... | 17 |
| 5.3.2 Picture types | 18 |
| 5.3.3 Compatibility..... | 18 |
| 5.3.4 User data | 19 |
| 5.3.5 Video alignment..... | 19 |
| 5.3.6 Chroma sampling location | 20 |
| 6 Video display formatting | 21 |
| 6.1 General | 21 |
| 6.2 Video format..... | 21 |
| 6.2.1 General | 21 |
| 6.2.2 Requirements for DVB compliance | 21 |
| 6.3 Recommendations for signalling in the video stream | 22 |
| 6.3.1 Sequence header | 22 |
| 6.3.2 Sequence display extension | 22 |
| 6.3.3 Constraints on the use of the picture display extension | 23 |
| 6.3.4 Format switching | 23 |
| 6.4 Video format signalling extensions | 24 |
| 6.4.1 General | 24 |
| 6.4.2 MPEG signalling..... | 24 |
| 6.4.3 DVB signalling..... | 24 |
| 6.4.4 Active format description | 24 |
| 6.5 Recommendations for ISO/IEC 13818-1 signalling..... | 32 |

| | | |
|-------|--|----|
| 6.6 | Alignment of SD video and graphics | 32 |
| 6.6.1 | Video with graphics | 32 |
| 6.6.2 | Uncertainty of position of graphics over video | 32 |
| 6.7 | Alignment of HD video and graphics | 33 |
| 7 | Audio system characteristics | 33 |
| 7.1 | General | 33 |
| 7.2 | Essential requirements | 33 |
| 7.2.1 | Requirements | 34 |
| 7.2.2 | Synchronisation | 34 |
| 7.2.3 | Audio metadata | 34 |
| 7.2.4 | Decoding requirements | 34 |
| 7.3 | Constraints and extensions | 35 |
| 7.3.1 | Digitally coded | 35 |
| 7.3.2 | Surround sound | 35 |
| 7.3.3 | AC-3 and Enhanced AC-3 audio | 35 |
| 7.3.4 | ISO/IEC 14496-3 audio | 36 |
| 7.3.5 | Receiver downmix | 36 |
| 7.3.6 | Digital audio output | 36 |
| 7.4 | Audio description | 36 |
| 7.4.1 | Background | 36 |
| 7.4.2 | Receiver implementation minima | 37 |
| 7.4.3 | Receiver mix AD signalling | 37 |
| 7.4.4 | Constraints on audio description stream coding | 41 |
| 7.4.5 | Receiver mix AD implementation notes | 41 |
| 7.4.6 | SI/PSI signalling | 43 |
| 7.5 | Audio only services | 45 |
| 8 | Multiplex and transport stream characteristics | 45 |
| 8.1 | Scope | 45 |
| 8.2 | Essential requirements | 45 |
| 8.2.1 | Multiplexing | 45 |
| 8.2.2 | Demultiplexing | 46 |
| 8.3 | Constraints and extensions | 46 |
| 8.3.1 | Multicomponent programs | 46 |
| 9 | Service and program specific information | 47 |
| 9.1 | General | 47 |
| 9.1.1 | General requirements | 47 |
| 9.1.2 | General receiver requirements | 47 |
| 9.1.3 | General broadcaster requirements | 48 |
| 9.1.4 | Notation | 49 |
| 9.2 | SI and PSI specification | 49 |
| 9.2.1 | Summary | 49 |
| 9.2.2 | Program association table | 51 |
| 9.2.3 | Program map table | 51 |
| 9.2.4 | Conditional access table | 53 |
| 9.2.5 | Network information table | 54 |
| 9.2.6 | Bouquet association table | 56 |
| 9.2.7 | Service description table | 56 |
| 9.2.8 | Event information table | 59 |
| 9.2.9 | Time and date table and time offset table | 62 |

| | | |
|--------|---|----|
| 9.2.10 | Running status table..... | 62 |
| 9.2.11 | Private data..... | 62 |
| 9.2.12 | Overview of service-variation options | 68 |
| 9.3 | Receiver functions..... | 69 |
| 9.3.1 | Information typically available to the user | 69 |
| 9.3.2 | Service change..... | 69 |
| 9.3.3 | Parental control | 72 |
| 9.3.4 | Receiver behaviour when a service stops | 72 |
| 9.4 | Establishing and maintaining the network connection | 73 |
| 9.4.1 | Use of SI identifiers | 73 |
| 9.4.2 | Auto installation..... | 74 |
| 9.4.3 | Network evolution | 76 |
| 9.4.4 | Logical channel numbers (LCN)..... | 78 |
| 9.4.5 | Recommendation for robust SI acquisition | 82 |
| 9.5 | User interface..... | 84 |
| 9.5.1 | Presentation of text | 84 |
| 9.5.2 | Information presentation..... | 85 |
| 9.5.3 | Service navigation | 87 |
| 9.5.4 | Display of time..... | 88 |
| 9.6 | Recording devices..... | 88 |
| 9.6.1 | General | 88 |
| 9.6.2 | Programming..... | 88 |
| 9.6.3 | Execution of recording..... | 88 |
| 9.6.4 | Control of analogue recorders | 89 |
| 10 | Subtitles | 89 |
| 10.1 | General..... | 89 |
| 10.2 | Broadcast specifications..... | 89 |
| 10.2.1 | DVB subtitles..... | 89 |
| 10.2.2 | Signalling | 90 |
| 10.2.3 | DDS | 90 |
| 10.2.4 | Recommendation..... | 90 |
| 10.3 | Receiver functions..... | 90 |
| 10.3.1 | Background | 90 |
| 10.3.2 | User control of receiver behaviour | 91 |
| 10.3.3 | Support for DDS | 91 |
| 11 | VBI based services..... | 91 |
| 11.1 | General..... | 91 |
| 11.2 | Broadcast specifications..... | 91 |
| 11.3 | Receiver functions..... | 92 |
| 11.3.1 | Processing capabilities | 92 |
| 11.3.2 | Control | 92 |
| 11.4 | Extended VBI format support..... | 92 |
| 11.4.1 | VPS..... | 93 |
| 11.4.2 | WSS..... | 93 |
| 11.4.3 | Teletext and teletext subtitles | 93 |
| 12 | RF-part and channel decoder | 93 |
| 12.1 | General..... | 93 |
| 12.2 | Frequencies and channel bandwidth..... | 93 |
| 12.3 | DVB-T modes..... | 93 |

| | | |
|-----------------------|--|-----|
| 12.4 | Tuning procedure | 94 |
| 12.5 | Change of modulation parameters | 94 |
| 12.6 | Connector | 94 |
| 12.7 | Performance..... | 94 |
| 12.7.1 | Failure point criteria..... | 94 |
| 12.7.2 | C/N performance | 94 |
| 12.7.3 | Minimum receiver signal input levels | 95 |
| 12.7.4 | Maximum input level..... | 95 |
| 12.7.5 | Immunity to analogue and/or digital signals in other channels..... | 95 |
| 12.7.6 | Immunity to co-channel interference from analogue TV signals..... | 96 |
| 12.7.7 | Guard interval utilisation in single frequency networks..... | 97 |
| 12.7.8 | MFN multipath performance..... | 97 |
| 13 | Conditional access and the common interface | 98 |
| 13.1 | General | 98 |
| 13.2 | Minimum requirements | 98 |
| 13.2.1 | Analogue Copy Protection Resource | 98 |
| 14 | System software update | 99 |
| 14.1 | General | 99 |
| 14.2 | Minimum requirements | 99 |
| 14.3 | Recommendations for SSU operators..... | 99 |
| 15 | Application Programming Interface (API)..... | 99 |
| 16 | Connectors..... | 100 |
| 16.1 | Standard receivers | 100 |
| 16.2 | Advanced receivers..... | 100 |
| 16.2.1 | Without display | 100 |
| 16.2.2 | With display..... | 101 |
| Annex A (normative) | SI character set..... | 102 |
| Annex B (normative) | DVB-SI PDC descriptor | 111 |
| Annex C (normative) | Subtitling | 113 |
| Annex D (informative) | An example of frequencies and offsets..... | 130 |
| Annex E (informative) | Noise model | 131 |
| Annex F (informative) | An example of C/N-performance with a practical transmitter..... | 132 |
| Annex G (informative) | Practical 6-path channel models for fixed and portable channels..... | 133 |
| Annex H (informative) | Interfering analogue signals | 134 |
| Bibliography | | 135 |
| Figure 1 | – Relationship between digital video and analogue video | 19 |
| Figure 2 | – Receiver and display format processing reference model | 26 |
| Figure 3 | – HD Receiver and display format processing reference model..... | 27 |
| Figure 4 | – Uncertainty of positioning graphics over video..... | 33 |
| Figure 5 | – Illustration of control of audio level..... | 38 |
| Figure 6 | – Mapping of pan byte onto sound presentation | 41 |
| Figure 7 | – Example of PMT extract for main programme audio | 44 |
| Figure 8 | – Example of PMT extract for audio description | 44 |
| Figure 9 | – Service regionalisation | 79 |
| Figure C.1 | – High level bitstream organisation..... | 114 |

| | |
|---|-----|
| Figure C.2 – Region depth selection | 116 |
| Figure C.3 – Mapping code strings to pixels in “requested” depth region..... | 117 |
| Figure C.4 – Mapping code strings to pixels..... | 118 |
| Figure C.5 – Subtitle reference decoder model | 120 |
| Figure C.6 – The two modelled decoding phases | 121 |
| Figure C.7 – Detail of data decoding phase | 122 |
| Figure C.8 – Disruption to display at start of new epoch..... | 122 |
| Figure E.1 – Tuner noise model | 131 |
| Figure H.1 – PAL interfering signals..... | 134 |
| Figure H.2 – SECAM L interfering signal..... | 134 |
| | |
| Table 1 – Broadcast overscan flags | 20 |
| Table 2 – Receiver overscan behaviour | 20 |
| Table 3 – Overscan signalling on HDMI | 20 |
| Table 4 – Horizontal scaling where format is signalled by the sequence header alone | 22 |
| Table 5 – Pan scan window | 23 |
| Table 6 – Non “full screen” | 23 |
| Table 7 – Formats described by the active_format description | 25 |
| Table 8 – Processing by STB connected to 4:3 TV..... | 28 |
| Table 9 – User options for displaying 16:9 on 4:3..... | 29 |
| Table 10 – User options for displaying >16:9 on 4:3..... | 29 |
| Table 11 – Processing by STB connected to 16:9 TV..... | 30 |
| Table 12 – WSS codes for aspect ratio | 31 |
| Table 13 – Values for other WSS bits | 31 |
| Table 14 – Audio description descriptor | 38 |
| Table 15 – Illustration of PES packet header | 40 |
| Table 16 – Key to symbols..... | 49 |
| Table 17 – Summary of required tables..... | 50 |
| Table 18 – Program descriptors | 51 |
| Table 19 – Elementary stream descriptors | 51 |
| Table 20 – Network descriptors (first loop)..... | 54 |
| Table 21 – Transport stream descriptors (second loop)..... | 55 |
| Table 22 – Service descriptors..... | 57 |
| Table 23 – Event information descriptors | 60 |
| Table 24 – Time offset table descriptors | 62 |
| Table 25 – Private SI recognised by this standard | 63 |
| Table 26 – Syntax of the eacem stream identifier descriptor | 63 |
| Table 27 – Syntax of the logical channel descriptor | 64 |
| Table 28 – Logical channel number | 65 |
| Table 29 – Syntax of the preferred name list descriptor | 65 |
| Table 30 – Syntax of the preferred name identifier descriptor | 66 |
| Table 31 – HD simulcast logical channel descriptor | 67 |
| Table 32 – Subtitle preference modes defined | 70 |

| | |
|---|-----|
| Table 33 – Receiver response to missing SI tables | 83 |
| Table 34 – Text field lengths | 85 |
| Table 35 – Delta values between picture failure point and reference BER | 94 |
| Table 36 – C/N (dB) for reference BER | 95 |
| Table 37 – Immunity to analogue signals on other channels | 96 |
| Table 38 – Immunity to digital signals on other channels | 96 |
| Table 39 – Immunity to co-channel interference from analogue signals | 96 |
| Table 40 – Long echo test profile | 97 |
| Table 41 – Short echo test profile | 97 |
| Table A.1 – Allowed character codes in SI text fields | 103 |
| Table B.1 – Syntax of the PDC descriptor | 111 |
| Table C.1 – Additional display update budget for page/region operations | 123 |
| Table C.2 – Example subtitle system performance | 126 |
| Table F.1 – C/N (dB) for reference BER | 132 |
| Table G.1 – Approximate 6-tap channel for fixed reception (Ricean channel) | 133 |
| Table G.2 – Approximate 6-tap channel for portable reception (Rayleigh channel) | 133 |

INTERNATIONAL ELECTROTECHNICAL COMMISSION

**DIGITAL TERRESTRIAL TELEVISION RECEIVERS
FOR THE DVB-T SYSTEM**
FOREWORD

- 1) The International Electrotechnical Commission (IEC) is a worldwide organization for standardization comprising all national electrotechnical committees (IEC National Committees). The object of IEC is to promote international co-operation on all questions concerning standardization in the electrical and electronic fields. To this end and in addition to other activities, IEC publishes International Standards, Technical Specifications, Technical Reports, Publicly Available Specifications (PAS) and Guides (hereafter referred to as "IEC Publication(s)"). Their preparation is entrusted to technical committees; any IEC National Committee interested in the subject dealt with may participate in this preparatory work. International, governmental and non-governmental organizations liaising with the IEC also participate in this preparation. IEC collaborates closely with the International Organization for Standardization (ISO) in accordance with conditions determined by agreement between the two organizations.
- 2) The formal decisions or agreements of IEC on technical matters express, as nearly as possible, an international consensus of opinion on the relevant subjects since each technical committee has representation from all interested IEC National Committees.
- 3) IEC Publications have the form of recommendations for international use and are accepted by IEC National Committees in that sense. While all reasonable efforts are made to ensure that the technical content of IEC Publications is accurate, IEC cannot be held responsible for the way in which they are used or for any misinterpretation by any end user.
- 4) In order to promote international uniformity, IEC National Committees undertake to apply IEC Publications transparently to the maximum extent possible in their national and regional publications. Any divergence between any IEC Publication and the corresponding national or regional publication shall be clearly indicated in the latter.
- 5) IEC provides no marking procedure to indicate its approval and cannot be rendered responsible for any equipment declared to be in conformity with an IEC Publication.
- 6) All users should ensure that they have the latest edition of this publication.
- 7) No liability shall attach to IEC or its directors, employees, servants or agents including individual experts and members of its technical committees and IEC National Committees for any personal injury, property damage or other damage of any nature whatsoever, whether direct or indirect, or for costs (including legal fees) and expenses arising out of the publication, use of, or reliance upon, this IEC Publication or any other IEC Publications.
- 8) Attention is drawn to the Normative references cited in this publication. Use of the referenced publications is indispensable for the correct application of this publication.
- 9) Attention is drawn to the possibility that some of the elements of this IEC Publication may be the subject of patent rights. IEC shall not be held responsible for identifying any or all such patent rights.

International Standard IEC 62216-1 has been prepared by technical area 1, Terminals for audio, video and data services and contents, of IEC technical committee 100: Audio, video and multimedia systems and equipment

The text of this standard is based on the following documents:

| | |
|--------------|------------------|
| CDV | Report on voting |
| 100/1449/CDV | 100/1541/RVC |

Full information on the voting for the approval of this standard can be found in the report on voting indicated in the above table.

This publication has been drafted in accordance with the ISO/IEC Directives, Part 2.

The committee has decided that the contents of this publication will remain unchanged until the maintenance result date indicated on the IEC web site under "<http://webstore.iec.ch>" in the data related to the specific publication. At this date, the publication will be

- reconfirmed,
- withdrawn,
- replaced by a revised edition, or
- amended.

A bilingual version of this publication may be issued at a later date.

INTRODUCTION

Television has evolved over the last half century from an up-market entertainment medium to becoming the major information tool around the world. Television is available to virtually all people around the globe, be it individually or in a community setting.

The advent of the “personal computer”, enabling global reach and instant interaction has escalated the demand for more and more information and the ability to respond to it instantly. It is thus that the broadcasters and content providers set out to seek new means of delivering higher levels of content, be it in volume or quality using existing or new transport mechanisms available.

Digitalisation, taken from the world of information technology was the obvious choice. It further brought the added benefits of efficient use of spectrum and energy. Terrestrial television has to migrate from analogue to digital in order to survive in the new information society.

Governments are keen to switch off the inefficient analogue broadcasts for a number of obvious reasons, but only will be able to do so when consumers are confident that the new proposition is attractive and affordable.

Due to the multitude of communities, sometimes single operators, often on a country by country basis dealing with the parameters and standards options of launching Digital Terrestrial services based on DVB, there is a natural tendency to create a variety of incompatible platforms tied to particular TV operators, and this in turn does not allow for economy of scale for all parties concerned, be it content providers, broadcasters, network providers or equipment manufacturers.

In 2000, after over two years of requirement capture in DigiTAG (Digital Television Action Group) EACEM (European Association of Consumer Electronics Manufacturers), which has evolved into EICTA (European Information, Communications and Consumer Electronics Technology Industry Associations), decided to address this situation by developing a basic specification as a minimum platform, providing secure reception of broadcast content and associated services. This resulted in the first revision of this standard. It has been used as a basis in many countries to deploy Digital Terrestrial TV (DTT) with great success.

In 2007, with a new wave of High Definition services being considered to be launched due to the availability of MPEG4 components, EICTA and the French “Forum HD” decided to collaborate to create an update for High Definition, and make some minor adjustments that were due after 7 years of practice with Standard Definition terrestrial TV in the market. The new standard improvements are taking into account contributions and comments from a.o. UK DTG (draft HD D-Book), Nordig and DGTVi. This standard does not yet address new generations of channel coding (DVB-T2) now being considered by DVB. Extensions of this standard in this domain may be foreseen in the future.

DIGITAL TERRESTRIAL TELEVISION RECEIVERS FOR THE DVB-T SYSTEM

1 Scope and object

This International Standard specifies both Standard Definition and High Definition receivers for the DVB-T system.

It concerns:

- broadcasters, and
- receiver manufacturers.

The objective is to define:

- how to provide broadcasts that are understood by all receivers and enable receivers to provide good facilities to their users;
- the behaviour required from receivers to work well with these broadcasts and to be attractive to consumers.

To avoid doubt, the words “shall”, “should”, etc. are used in the traditional way to distinguish issues that are mandatory versus those that are optional. A baseline receiver will support the mandatory features but not all the optional features in this standard. Inclusion of optional features is part of the marketing strategy of the manufacturer.

Subtitling and teletext are considered to be components of TV services. Standalone teletext services (without associated video content) are not part of this standard.

This standard primarily addresses terrestrial delivery of digital transmissions.

This standard primarily addresses deployment in countries that use European Latin script based languages.

Two types of systems are considered:

- standard systems where services are all SD and use well-established codecs. Standard receivers which can decode standard services are suitable for these systems;
- advanced systems where some services may use advanced codecs, for example to provide HD video. Advanced receivers which can decode advanced services are suitable for these systems.

Where the term “receiver” or “broadcast” is used without a qualifier, the statement is applicable equally to both types of systems.

2 Normative references

The following referenced documents are indispensable for the application of this document. For dated references, only the edition cited applies. For undated references, the latest edition of the referenced document (including any amendments) applies.

IEC 61169-2, *Radio-frequency connectors – Part 2: Sectional specification – Radio frequency coaxial connectors of type 9,52*

IEC 60958-1, *Digital audio interface – Part 1: General*

IEC 61937 (all parts), *Digital audio – Interface for non-linear PCM encoded audio bitstreams applying IEC 60958*

ISO/IEC 6937, *Information technology – Coded graphic character set for text communication – Latin alphabet*

ISO/IEC 8859-9, *Information technology – 8-bit single-byte coded graphic character sets – Part 9: Latin alphabet No. 5*

ISO/IEC 11172-2, *Information technology – Coding of moving pictures and associated audio for digital storage media at up to about 1,5 Mbit/s – Part 2: Video*

ISO/IEC 13818-1, *Information technology – Generic coding of moving pictures and associated audio information: Systems*

ISO/IEC 13818-2, *Information technology – Generic coding of moving pictures and associated audio information: Video*

ISO/IEC 13818-3, *Information technology – Generic coding of moving pictures and associated audio information: Audio*

ISO/IEC 14496-3, *Information Technology – Coding of audio-visual objects –Part 3: Audio*

ISO/IEC 14496-10, *Information technology – Coding of audio-visual objects – Part 10: Advanced Video Coding*

ISO 639-2, *Codes for the representation of names of languages – Part 2: Alpha-3 code*

ITU-R BS.775-2, *Multichannel stereophonic sound system with and without accompanying picture*

ITU-R BT.470-7 *Conventional television systems*

ITU-R BT.1119-2, *Wide-screen signalling for broadcasting (Signalling for wide-screen and other enhanced television parameters)*

ITU-R BT.1359-1, *Relative timing of sound and vision for broadcasting*

EN 50049-1, *Domestic and similar electronic equipment interconnection requirements: Peritelevision connector*

EN 50221, *Common Interface Specification for Conditional Access and Other Digital Video Broadcasting Decoder Applications*

EN 300 294, *Television Systems – 625-line television Wide Screen Signalling (WSS)*

EN 300 468, *Digital Video Broadcasting (DVB) – Specification for Service Information (SI) in DVB systems*

EN 300 472, *Digital Video Broadcasting (DVB) – Specification for conveying ITU-R System B Teletext in DVB bitstreams*

EN 300 743, *Digital Video Broadcasting (DVB) – Subtitling systems*

EN 300 744, *Digital Video Broadcasting (DVB) – Framing structure, channel coding and modulation for digital terrestrial television*

EN 301 775, *Digital Video Broadcasting (DVB) – Specification for the carriage of Vertical Blanking Information (VBI) data in DVB bitstreams*

ETR 162, *Digital broadcasting systems for television sound and data services; Allocation of Service Information (SI) codes for Digital Video Broadcasting (DVB) systems*

Note that the allocation of identifiers is handled by DVB; up-to-date information on DVB identifiers can be obtained from <www.dvb.org>.

ETR 289, *Digital Video Broadcasting (DVB) – Support for use of scrambling and Conditional Access (CA) within digital broadcasting systems*

ETS 300 231, *Television systems; Specification of the domestic video Programme Delivery Control system (PDC)*

ETS 300 706, *Enhanced Teletext specification*

R206-001, *Guidelines for Implementation and Use of the Common Interface for DVB Decoder Applications*

TS 101 154, *Digital Video Broadcasting (DVB); Implementation guidelines for the use of Video and Audio Coding in Broadcasting Applications based on the MPEG-2 Transport Stream*

TR 101 211, *Digital Video Broadcasting (DVB); Guidelines on implementation and usage of Service Information (SI)*

TS 101 699, *Digital Video Broadcasting (DVB); Extensions to the Common Interface Specification*

TS 102 006, *Digital Video Broadcast (DVB); Specification for System Software Update in DVB systems*

TS 102 366, *Digital Audio Compression (AC-3, Enhanced AC-3) Standard*

CEA 770.3, *High Definition TV Analog Component Video Interface*

CEA 861, *A DTV Profile for Uncompressed High Speed Digital Interfaces*

3 Abbreviations and symbols

| | |
|-------|-----------------------------------|
| AD | Audio Description |
| AFD | Active Format Description |
| API | Application Programming Interface |
| AU | Access Unit |
| BAT | Bouquet Association Table |
| bslbf | Bit string, left bit first |
| CA | Conditional Access |
| CCO | Centre Cut-Out |
| DDS | Display Definition Segment |

| | |
|--------------------|---|
| DTS | Digital Theatre System |
| DTT | Digital Terrestrial Television |
| DVB | Digital Video Broadcast |
| EBU | European Broadcast Union |
| EIT | Event Information Table |
| EIT _{pf} | EIT present/following |
| EPG | Electronic Programme Guide |
| FF | Full Frame |
| IDTV | Integrated Digital Television |
| IPPV | Impulse Pay Per View |
| HD | High Definition |
| HDCP | High-bandwidth Digital Content Protection |
| HDMI™ ¹ | High Definition Multimedia Interface™ |
| LB | Letter Box |
| LCN | Logical Channel Number |
| MFN | Multi Frequency Network |
| MTBF | Mean Time Between Failure |
| NIT | Network Information Table |
| NVOD | Near Video On Demand |
| PCS | Page Composition Segment |
| PDC | Programme Delivery Control |
| PES | Packetised Elementary Stream |
| PIL | Programme Identification Label |
| PMT | Program Map Table |
| PSI | Program Specific Information |
| PTS | Presentation Time Stamp |
| RNIB | Royal National Institute for the Blind |
| RST | Running Status Table |
| SD | Standard Definition |
| SDT | Service Description Table |
| SFN | Single Frequency Network |
| SI | Service Information |
| SSU | System Software Update |
| STB | Set Top Box |
| TDT | Time and Date Table |
| TOT | Time Offset Table |
| TS | Transport Stream |

¹ HDMI and High-Definition Multimedia Interface are trade marks of the HDMI Licensing, LLC. This information is given for the convenience of users of this document and does not constitute an endorsement by IEC of the product named.

| | |
|--------|---|
| UCS | Universal Character Set |
| uimsbf | Unsigned integer most significant bit first |
| UNT | Update Notification Table |
| UTC | Universal Time, Co-ordinated |
| VUI | Video Usability Information |
| VCR | Video Cassette Recorder |
| VPS | Video Programming System |
| WSS | Wide Screen Signalling |

4 Receiver capabilities

4.1 Frequency spectrum

The receiver shall support:

- UHF and/or VHF (band III);
- 8 MHz and/or 7 MHz channel bandwidth;
- all DVB-T modulation methods;
- both 2K and 8K transmitting methods;
- all code rates;
- all guard intervals;
- hierarchical mode by the demodulator (optional);
- frequency offset management;
- multi-frequency networks (MFNs) and single frequency networks (SFNs);
- support DVB-H service discrimination.

4.2 Conditional access

The receiver is capable of receiving free-to-air services and is recommended to provide access to scrambled services. In order to have the needed flexibility to choose a Conditional Access (CA) system one Common Interface slot (according to EN 50221) is foreseen. In the future other means to add new CA systems might be used instead.

4.3 Return path

If a modem is not embedded then suitable means should be provided for connection to one (for example RS 232) or to the internet for further interactive applications (for example IPPV).

4.4 EPG (SI)

The electronic programme guide (EPG) shall use the mandatory service information broadcast in the service information table and the event information table to present appropriate service and event information to the user and to allow automatic selection of service features when the user selects a service.

Details can be found in Clause 9, which is based on (mandatory) DVB-SI rules.

4.5 Auto installation

The receiver shall allow access to all receivable services and will use the mandatory information in the NIT and/or SDT to automate the initialisation of the service list and subsequent updates thereof. See also 9.4.2.

4.6 Teletext carried in digital streams

Support of this feature is the responsibility of the manufacturer. Manufacturers are prepared to support teletext for a transition period. This feature and its signalling is described in Clause 11. In order to allow for future phase-out, DVB-subtitle decoding is the recommended transmission format for subtitling.

4.7 Content protection/copy management

Analogue recording via the peritelevision connector (EN 50049-1) is supported.

Digital content protection using HDCP on the HDMI output connector should be supported on receivers without integrated video display.

4.8 Services

The receiver shall support the following services and service features:

- free to air broadcast;
- multi-lingual sound;
- multi-lingual subtitles (DVB subtitles);
- audio broadcast;
- screen formatting for ratios of 4:3 and 16:9;
- content rating protection based on DVB standard (see 9.2.8.1.7 and 9.3.3).

In addition, the receiver may support:

- teletext linked with a program;
- mosaic services;
- Automatic Format Descriptor (AFD) for flexible screen formatting.

4.9 API

The receiver may support an API in order to facilitate interactive TV services. See Clause 15.

4.10 Over-air software update

The receiver may support the DVB System Software Update service in order to permit maintenance or functional upgrades once the receiver is deployed in the field. See Clause 14.

4.11 Audio and video codecs

A standard receiver shall at least support MPEG-2 audio and SD video.

An advanced receiver shall, in addition, support:

- ISO/IEC 14496-10 SD and HD video, as specified in TS 101 154;
- either ISO/IEC 14496-3 HE-AAC audio (v1 only, i.e. not including the Parametric Stereo tool) or TS 102 366 Enhanced AC-3 audio, as specified in TS 101 154;

- multi-channel audio, encoded using one of the codecs in the previous bullet, up to 5.1 channels.

4.12 Future versions of this standard

It is the intention to extend this standard in a backward compatible way towards new types of services and service options and consequent receiver behaviour.

5 Video system characteristics

5.1 General

This clause defines the digital video encoding standards that shall be used.

It is based on the D-Book version 3.0.

5.2 Essential requirements

5.2.1 Standard services

Broadcast video shall be encoded according to ISO/IEC 13818-2 constrained according to TS 101 154. All receivers should be able to meet the minimum decoding requirements set out in TS 101 154.

Only the '25 Hz MPEG-2 SDTV' variant described in the 'Video' clause of TS 101 154 is relevant to this standard.

5.2.2 Advanced services

Broadcast video shall be encoded according to ISO/IEC 14496-10 (H.264/AVC) constrained according to TS 101 154. All advanced receivers should be able to meet the minimum decoding requirements set out in TS 101 154.

Only the '25 Hz H.264/AVC SDTV' and '25 Hz H.264/AVC HDTV' variants (plus the Common parts) described in the 'Video' clause of TS 101 154 are relevant to this standard.

5.3 Constraints and extensions

This clause sets out the additional requirements on the broadcast signals and reception equipment in addition to the DVB requirements in TS 101 154.

5.3.1 Support for rapid channel acquisition

To reduce the typical time taken to start decoding a new service, each video elementary stream carrying ISO/IEC 13818-2 encoded video shall contain a sequence header and associated group of pictures header at an interval no greater than 0,5 s. Also, each such sequence header shall be immediately preceded by a PES packet header carrying a PTS².

For video encoded to ISO/IEC 14496-10, random access points shall be inserted at an interval no greater than 2 s and should be inserted at an interval no greater than 0,5 s where channel change speed is important.

Receivers should still be able to decode the video elementary stream when these figures are exceeded.

² TS 101 154 recommends but does not mandate this.

There is no requirement to set the data alignment indicator flag in the PES packet header or for the broadcast to include a data stream alignment descriptor associated with the video elementary stream in the PMT. If a data stream alignment descriptor is included for a video elementary stream then it shall indicate alignment type '04'.

5.3.2 Picture types

Beyond the requirements of ISO/IEC 13818-2 and the requirement for periodic I pictures implied by 5.3.1, no additional constraints are placed on the sequence of coded picture types. Specifically, no additional constraints are placed on the number of B pictures between I and P pictures. As required by the main profile of ISO/IEC 13818-2, broadcasts may use I, P, B and dual-prime frame types.

Advanced services encoded to ISO/IEC 14496-10 shall follow the restrictions of picture and slice types set out in TS 101 154.

5.3.3 Compatibility

5.3.3.1 ISO/IEC 11172-2 compatibility

TS 101 154 requires that video encoding shall conform to the ISO/IEC 13818-2 main profile at main level. This requires support for ISO/IEC 11172-2 'D' pictures and "constrained parameters" video.

Broadcasts conforming to this standard shall not include ISO/IEC 11172-2 'D' pictures or sequences with a `horizontal_size` greater than 720.

5.3.3.2 ISO/IEC 14496-10 compatibility

5.3.3.2.1 Standard definition

Standard definition video services shall be encoded according to TS 101 154 except that High Profile may be used in markets where HD services are also broadcast. This means that receivers shall support video encoding up to ISO/IEC 14496-10 High Profile level 3. Receiver's support other profiles beyond High Profile is optional. Support of levels beyond level 3 is optional. If the receiver encounters an extension which it cannot decode, it shall discard the following data until the next start code prefix (to allow backward compatible extensions to be added in the future).

Broadcasts conforming to this standard shall not include sequences with a `horizontal_size` greater than 720.

5.3.3.2.2 High definition

TS 101 154 requires that high definition video encoding shall conform to ISO/IEC 14496-10 High Profile level 4. Receiver's support for profiles other than High Profile or levels outside the range 3.0 to 4.0 is optional. If the receiver encounters an extension which it cannot decode, it shall discard the following data until the next start code prefix (to allow backward compatible extensions to be added in the future).

Broadcasts conforming to this standard shall not include sequences with a `horizontal_size` greater than 1920.

5.3.3.2.3 Still pictures

Advanced receivers shall support the decoding and display of still pictures for all AVC profiles.

To signal a video stream containing still pictures, the broadcast shall set the `AVC_still_present` flag in the AVC descriptor, as specified in ISO/IEC 13818-1. The receiver

shall decode the still picture frame and repeat displaying it until the subsequent (still picture) frame is available to display.

NOTE Broadcasts containing still pictures are typically at very low frame rates (for example 1 frame per second).

5.3.4 User data

To ensure good functionality in current and future receiver video decoder implementations, a buffer model for user data within the video elementary stream is defined. The currently proposed use for this is to carry the “active format description” described in 6.4.4. This only exploits a small number of the bytes that might be used. Broadcasts are not required to carry this data.

If user data is carried, it shall meet the following buffer model:

- all user data bytes enter a single buffer of size 16 bytes (the user data start code is discarded before data is delivered to the buffer);
- all the data delivered at one time is removed from the buffer no later than 40 ms after it was delivered.

5.3.5 Video alignment

5.3.5.1 Analogue SD output signal

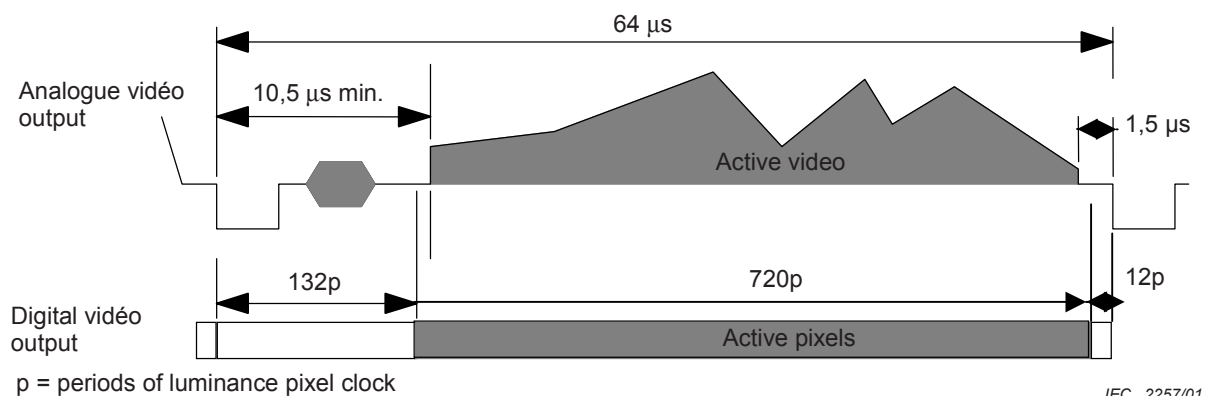

Figure 1 – Relationship between digital video and analogue video

The digital video output of the receiver’s video decoder and graphics display system domain contains 720 active pixels per line; these shall be aligned to the SD analogue video output signal as shown in Figure 1.

It should be noted that:

- at least the first 9 and the last 9 of the 720 video pixels should be replaced with a blanking level to ensure compliance with ITU-R BT.470-7;
- optionally, additional blanking may be applied to the start and end of the active video, suppressing further active pixels;
- the position of the first of the 720 active video pixels corresponds to 132 pixel periods ($\approx 9,8 \mu\text{s}$) after the falling edge of line sync;
- the figure is specific for PAL output signals. For receivers with SECAM output signals, similar positioning and blanking shall be done.

5.3.5.2 Overscan

Typically a 5 % border region inside each edge of the 702×576 pixel area is not visible due to overscan on a display.

For services carrying ISO/IEC 14496-10 video, the broadcaster may use the `overscan_info_present` and `overscan_appropriate` flags in the VUI area to indicate whether the receiver should apply this typical overscan or should display the complete broadcast video image. The flags shall be encoded according to Table 1.

Table 1 – Broadcast overscan flags

| <code>overscan_info_present_flag</code> | <code>overscan_appropriate_flag</code> | Usage |
|---|--|--|
| 0x0 or not broadcast | n/a | No preferred display method |
| 0x1 | 0x0 | Important information in entire video region |
| 0x1 | 0x1 | Decoded picture suitable for overscan |

Unless the user requests otherwise, integrated digital TV receivers shall interpret and follow the overscan flags according to Table 2.

Table 2 – Receiver overscan behaviour

| <code>overscan_info_present_flag</code> | <code>overscan_appropriate_flag</code> | Behaviour |
|---|--|--------------------------|
| 0x0 or not broadcast | n/a | Implementation dependent |
| 0x1 | 0x0 | Overscan not applied |
| 0x1 | 0x1 | Overscan applied |

For receivers with HDMI output, the receiver shall pass the video without overscan related reformatting to its output, setting the bits in the AVI Infoframe (see CEA 861) in accordance with Table 3.

Table 3 – Overscan signalling on HDMI

| <code>overscan_info_present_flag</code> | <code>overscan_appropriate_flag</code> | <S1,S0> (in HDMI AVI Infoframe) |
|---|--|---------------------------------|
| 0x0 or not broadcast | n/a | <0,0> |
| 0x1 | 0x0 | <1,0> |
| 0x1 | 0x1 | <0,1> |

5.3.5.3 Downscaling HD video to SD

When downscaling HD video for presentation via an SD output, the HD video should be downscaled to fit in a 702 × 576 window centred in the SD video output.

5.3.5.4 Upscaling SD video to HD

When upscaling SD video for presentation via an HD output, only the 702 × 576 window of the SD video should be upscaled to fit in the HD video output.

5.3.6 Chroma sampling location

When the video is encoded according to ISO/IEC 14496-10, the chrominance locations shall be specified in the VUI by the syntax elements `chroma_sample_loc_type_top_field` and `chroma_sample_loc_type_bottom_field` and both of these values shall be set to "0".

6 Video display formatting

6.1 General

This clause, which is based on the D-Book version 3.0, describes the video format signalling and how it may be used. The receiver response to this signalling is defined in this clause.

This clause:

- provides a summary of the “applicable standards”;
- introduces “recommendations for signalling in the video stream”;
- defines “video format signalling extensions”;
- defines requirements for “alignment of video and graphics”.

6.2 Video format

6.2.1 General

The video format shall be encoded as described in ISO/IEC 13818-1, ISO/IEC 13818-2, ISO/IEC 14496-10 and EN 300 468 constrained and interpreted as described in TR 101 211 and TS 101 154 and as clarified and extended below.

Only the ‘25 Hz MPEG-2 SDTV’ variant described in the ‘Video’ clause of TS 101 154 is relevant for standard services; the ‘25Hz H.264/AVC SDTV’ and ‘25Hz H.264/AVC HDTV’ variants plus the Common parts are in addition relevant for advanced services.

6.2.2 Requirements for DVB compliance

6.2.2.1 Required format information

The following element shall be included for all video services:

- component descriptor (EN 300 468).

The following element shall be included for all ISO/IEC 13818-2 standard video services:

- video sequence header. Restricted to “full screen” luminance pixel resolutions of 720×576 , 704×576 , 544×576 , 480×576 , 352×576 or 352×288 or “less than full screen” resolutions as described in TS 101 154.

The following elements shall be included for all ISO/IEC 14496-10 advanced video services:

- random access point. Restricted to “full screen” luminance pixel resolutions of 720×576 , 704×576 , 544×576 , 480×576 , 352×576 , 352×288 , $1\,920 \times 1\,080$, $1\,440 \times 1\,080$, $1\,280 \times 1\,080$, $960 \times 1\,080$, $1\,280 \times 720$, 960×720 , 640×720 or “less than full screen” resolutions as described in TS 101 154.
- frame cropping information for 1080 line video resolutions to crop the encoded 1088 lines to 1080 lines. Frame cropping shall not be used for any other purpose.

If the frame cropping information is not present in a video stream with 1 088 encoded lines, the receiver shall discard the bottom 8 lines.

6.2.2.2 Optional to broadcast, required to decode

All conformant receivers are required to respond to the above mandatory information and shall also respond to the following optionally broadcast information:

- video sequence display extension (ISO/IEC 13818-2 or ISO-IEC 14496-10), provided that the display window has an aspect ratio of 4:3 as described in TS 101 154;

- video picture display extension (ISO/IEC 13818-2), provided that the frame centre vertical offset is zero as described in TS 101 154;
it is mandatory to include the video sequence extension in any video sequence that includes the picture display extension (and hence Pan vectors (as defined in TS 101 154));
- target background grid descriptor (ISO/IEC 13818-1);
- video window descriptor (ISO/IEC 13818-1).

6.3 Recommendations for signalling in the video stream

6.3.1 Sequence header

6.3.1.1 Sequence header (ISO/IEC 13818-2 video)

The minimum video format signalling required is the video sequence header. Table 4 tabulates the horizontal scaling factors required to restore video to 720 pixel horizontal resolution with the correct aspect ratio. These factors complement the scaling factors employed by the broadcaster when downsampling the video before encoding.

Table 4 – Horizontal scaling where format is signalled by the sequence header alone

| | | | Source aspect ratio ^a | | |
|---|-----------------------------------|--|---|------------------|--------------|
| horizontal_size | Nominal “full screen” width | Effective horizontal size ^b | 4:3 | 16:9 | |
| 545 to 720 | 720 | 720 | 1 | 4/3 ^c | 1 |
| 481 to 544 | 544 | 540 | 4/3 | 16/9 | 4/3 |
| 353 to 480 | 480 | 480 | 3/2 | 2 | 3/2 |
| 1 to 352 | 352 | 360 | 2 | 8/3 | 2 |
| | | | 4:3 display | | 16:9 display |
| | | | Horizontal scaling to fill 720 wide display | | |
| <p>a From the aspect ratio information.</p> <p>b For example, values of horizontal_size from 481 to 544 are treated as 540 when determining the scaling factor to adapt the video for a 720 pixel wide display, i.e. $720/540 = 4/3$.</p> <p>c These scaling factors apply to a centre cut-out presentation, i.e. the central 3/4 of the coded picture width is scaled by the factor indicated to fill the width of a 4:3 display.</p> | | | | | |

6.3.1.2 Sequence parameter set (ISO/IEC 14496-10 video)

The minimum video format signalling required is the random access point. The relevant scaling factors, extracted from the VUI, to be used to restore the video to the correct size and aspect ratio are listed in TS 101 154.

6.3.2 Sequence display extension

6.3.2.1 Pan scan window

Here, the sequence display extension describes a 4:3 aspect ratio window within 16:9 coded frame (the position of this window may be controlled by the picture display extension).

Table 5 – Pan scan window

| display_horizontal_size | | | Effective horizontal size ^a | Horizontal scaling | |
|-------------------------|----------------------|------|--|--------------------------|-------------------------------|
| Min. | Typical ^b | Max. | | Window fills 4:3 display | Full frame fills 16:9 display |
| 409 | 540 | 540 | 540 | 4/3 | 1 |
| 364 | 408 | 408 | 405 | 16/9 | 4/3 |
| 271 | 360 ^c | 363 | 360 | 2 | 3/2 |
| 1 | 264 | 270 | 270 | 8/3 | 2 |

a Scaling to make the display window fill 4:3 display is 720/effective horizontal size.
b Recommended to broadcast. Is 3/4 of the nominal "full screen" width.
c TS 101 154 and DAVIC quote 363 as an example of 480 × 3/4.

6.3.2.2 Non "full screen"

Here, the sequence display extension describes a window (4:3 or 16:9) that surrounds the coded frame.

Table 6 – Non "full screen"

| display_horizontal_size | effective horizontal size ^a | horizontal scaling to fill display of same aspect ratio ^b | Note |
|-------------------------|--|--|---|
| 720 704 | 720 | 1 | |
| 544 528 | 540 | 4/3 | Distinguished from Table 5 as display_horizontal_size ≥ horizontal_size |
| 480 | 480 | 3/2 | |
| 352 | 360 | 2 | |

a Scaling to make display window fill appropriate display is 720/effective horizontal size.
b In other words, to fill a 4:3 display if the aspect ratio information is 0010₂ or 16:9 display if the aspect ratio information is 0011₂.

6.3.3 Constraints on the use of the picture display extension

The picture display extension may be included in broadcasts to define non-zero valued frame centre horizontal offsets (known as a pan vector).

When provided, receivers shall use this information only when configured to display a 4:3 cut-out from a widescreen source on a 4:3 display. The horizontal offset should be ignored if the material is displayed in a letter box on the 4:3 display.

6.3.4 Format switching

Receivers complying with this standard shall be able to continue outputting decoded video pictures undisturbed by changes in the video format parameters provided that these changes are constrained as follows:

- changes are implemented at a sequence boundary (ISO/IEC 13818-2) or random access point (ISO/IEC 14496-10);
- vertical_size and display_vertical_size remain unchanged;
- the buffer models defined by MPEG are met;

- the field parity of the first displayed field of the new sequence complements that of the last displayed field of the preceding sequence (interlaced video only).

Specifically, this allows the following parameters to be changed:

- coded picture width (`horizontal_size`), and
- coded pixel aspect ratio (`aspect_ratio_information`, `display_horizontal_size`).

Broadcasters should avoid changing the format of the video dynamically.

Broadcasters are advised that changing the format of the video will result in temporary artefacts on receivers. A typical receiver may require the time between the first and second random access points for processing a format change. Receivers should minimize the impact of a format change to a few seconds (depending on random access points in the video).

6.4 Video format signalling extensions

6.4.1 General

DVB requires receivers to support 16:9 and 4:3 coded video (support for 2,21:1 is optional). However, additional origination formats are prevalent in some countries (such as the 15:9 format Super 16 film) and invented formats (such as 14:9) may be used to accommodate the delivery of mixed formats to a heterogeneous receiver population.

This subclause describes how these additional formats may be conveyed compatibly within the standard DVB coded picture formats.

6.4.2 MPEG signalling

The use of the signalling methods within the MPEG video elementary stream is unchanged from that described previously, i.e. the sequence header and the sequence display extension parameters or VUI parameters describe either a 16:9 or a 4:3 aspect ratio coded frame that is either one of the full screen formats or a cropped version of one of these.

“Pan vectors” may be included in a broadcast that also uses the active format description. “Pan vectors”, and the active format description provide alternative, mutually exclusive, methods of displaying widescreen material on a 4:3 display.

6.4.3 DVB signalling

The EN 300 468 Component descriptor shall be appropriate for the coded frame type of the video, i.e. 4:3 or 16:9 (with or without “Pan vectors”).

6.4.4 Active format description

Active format descriptions as defined in Annex B of TS 101 154 serve to describe the portion of the 16:9 or 4:3 coded frame that is “of interest”. The format descriptions are informative in nature and are provided to assist receivers to optimise their presentation of video.

Table 7 (copied from TS 101 154) illustrates the various formats.

6.4.4.1 Broadcaster rule

If the area of interest is smaller than the full coded frame then it is recommended to transmit the active format description to indicate the area of interest.

6.4.4.2 Manufacturer rule

It is recommended that receivers use this active format description (if transmitted) to allow optimised presentation.

Table 7 – Formats described by the active_format description

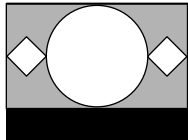
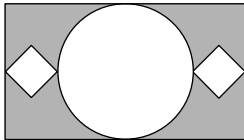
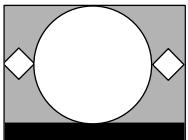
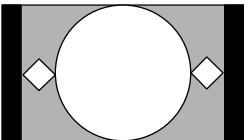
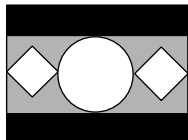
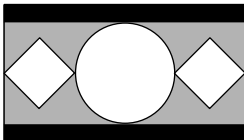
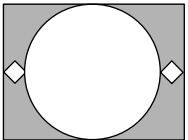
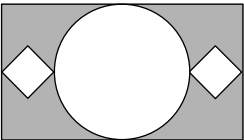
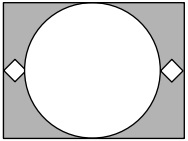
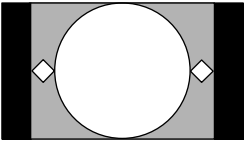
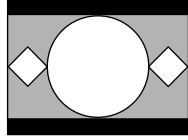
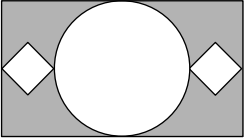
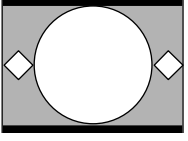
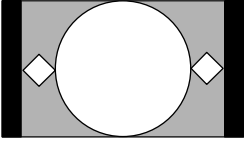
| active_format | | Full frame aspect ratio | |
|---------------|--|---|--|
| Value | Meaning | 4:3 | 16:9 |
| 0000 – 0001 | Reserved for future use | | |
| 0010 | Box 16:9 (top) |  |  |
| 0011 | Box 14:9 (top) |  |  |
| 0100 | Box > 16:9 (centre) |  |  |
| 0101 – 0111 | Reserved for future use | | |
| 1000 | Active format is the same as the coded frame |  |  |
| 1001 | 4:3 (centre) |  |  |
| 1010 | 16:9 (centre) |  |  |
| 1011 | 14:9 (centre) |  |  |
| 1100 | Reserved for future use | | |

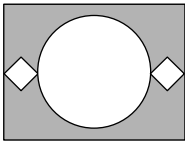
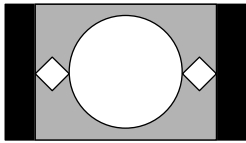
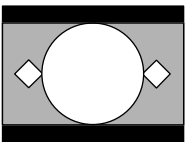
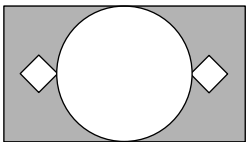
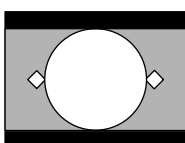
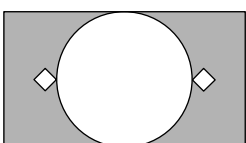
| active_format | | Full frame aspect ratio | |
|---------------|---|---|--|
| Value | Meaning | 4:3 | 16:9 |
| 1101 | 4:3 (with shoot and protect 14:9 centre) |  |  |
| 1110 | 16:9 (with shoot and protect 14:9 centre) |  |  |
| 1111 | 16:9 (with shoot and protect 4:3 centre) |  |  |

NOTE It is recommended to use the 4:3 coded frame mode to transmit 4:3 source material rather than using a pillar box to transmit it in a 16:9 coded frame. This allows for higher horizontal resolution on both 4:3 and 16:9 sets.

6.4.4.3 Receiver processing

6.4.4.3.1 SD reference model

The reference model for the video format processing elements in the set top box, TV and integrated digital TV are illustrated in Figure 2. The behaviour of the integrated digital TV is logically equivalent to that of a set top box attached to a TV. The display format signalling between the set top box and the display is Line 23 WSS (see 6.4.4.7) and/or peritelevision connector pin 8. Within an integrated digital TV, the signalling is logically equivalent to WSS but could be conveyed by other means.

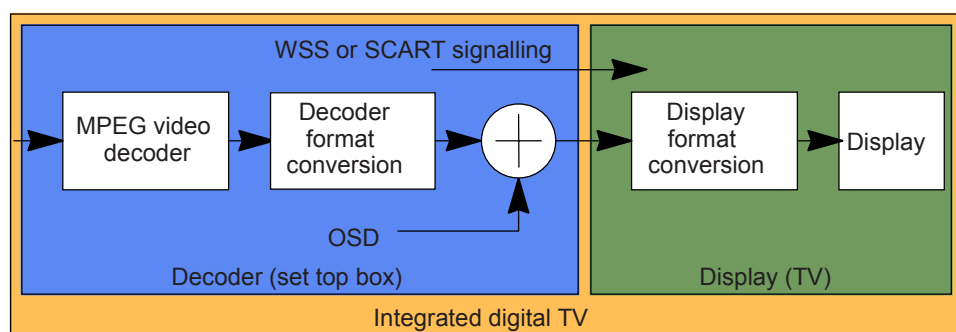

IEC 2258/01

Figure 2 – Receiver and display format processing reference model

In the reference model, the output of the MPEG video decoder is logically 720×576 . The processing applied to this by the decoder format conversion is described in Tables 5 and 8. In many practical implementations, the processes in the decoder format conversion are an integral part of the MPEG video decoder. This does not affect the logical reference model.

The decoder format conversion is principally concerned with the processing provided in 16:9 displays to accept 4:3 signals.

6.4.4.3.2 HD reference model

The reference model for the video format processing elements in the Set Top Box, TV and Integrated Digital TV are illustrated in Figure 3. The behaviour of the Integrated Digital TV is logically equivalent to that of a Set Top Box attached to a TV. The display format signalling between the Set Top Box and the display is the HDMI INFO-FRAME. Within an Integrated Digital TV the signalling is logically equivalent to the INFO-FRAME but could be conveyed by other means.

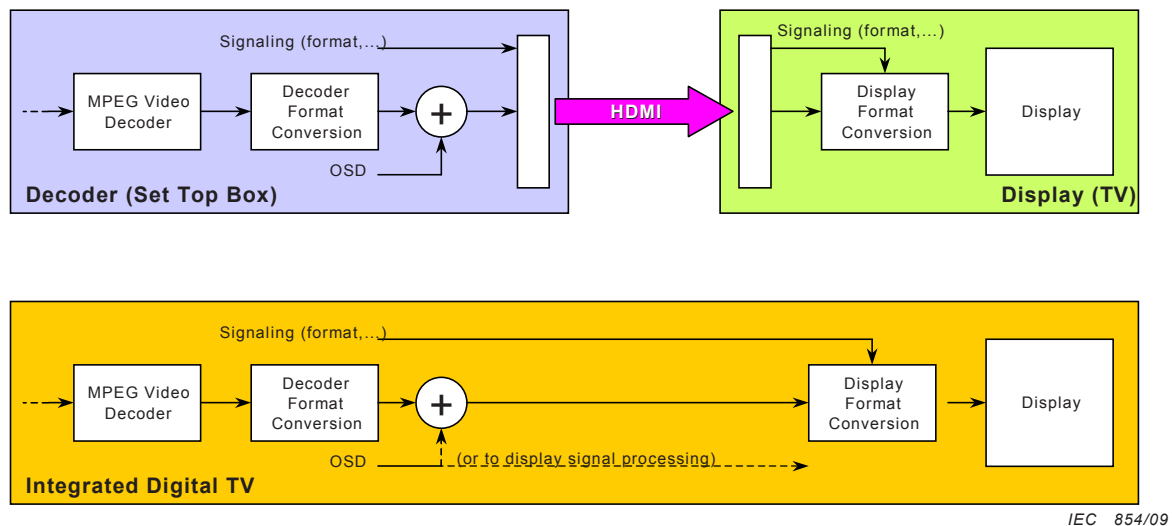

Figure 3 – HD Receiver and display format processing reference model

In the reference model the output of the MPEG Video Decoder is logically 1920×1080 , 1280×720 or 720×576 , the processing applied to this by the Decoder Format Conversion is described previously. In many practical implementations, the processes in the Decoder Format Conversion are an integral part of the MPEG Video Decoder. This does not affect the logical reference model.

The format of the video output by an STB to a display will be determined by the capabilities of both devices and may not correspond with the format of the broadcast video. The STB should avoid undue scaling operations as this will degrade the quality of the video.

If the STB or Integrated Digital TV has a secondary SD output, this shall operate according to the reference model in 6.4.4.3.1 with implicit downscaling of the video to 720×576 and optionally the processing of any AFD.

6.4.4.4 STB with 4:3 display

6.4.4.4.1 STB response

Table 8 shows the response of a set top box to all broadcast formats when connected to a 4:3 aspect ratio display.

Table 8 – Processing by STB connected to 4:3 TV

| Broadcast format | | | STB into 4:3 display | | |
|--|-------------------|-------------------|---|----------------------------|-----------------------------------|
| Description of format | On-air signalling | | Decoder format conversion | Signalling to TV | |
| | MPEG | active_ format | | WSS codes for aspect ratio | Peritelevision connector Pin 8 |
| 16:9 letter box (top) | 4:3 | 0010 | FF | 0010 | 12 V |
| 14:9 letter box (top) | | 0011 | | 0100 | |
| >16:9 letter box | | 0100 | | 1011 | |
| 4:3 | | 1000 | | 0001 | |
| | | 1001 | | | |
| 16:9 letter box | | 1010 | | 1101 | |
| 14:9 letter box | | 1011 | | 1000 | |
| Full 4:3 shoot and protect 14:9 | | 1101 | | 0111 | |
| 16:9 LB shoot and protect 14:9 | | 1110 | | 1101 | |
| 16:9 (with shoot and protect 4:3 centre) | | 1111 | | | |
| 16:9 letter box (top) | 16:9 | 0010 | According to user preference. See Table 9 | | |
| 14:9 letter box (top) | | 0011 | CCO ^{a)} | 0001 | 12 V |
| >16:9 letter box | | 0100 | According to user preference. See Table 10 | | |
| 16:9 | | 1000 | According to user preference. See Table 9 | | |
| 4:3 pillar box | | 1001 | CCO | 0001 | 12 V |
| 16:9 | | 1010 | According to user preference. See Table 9 | | |
| 14:9 pillar box | | 1011 | CCO ^{a)} | 0001 | 12 V |
| 4:3 PB shoot and protect 14:9 | | 1101 | CCO | 0001 | 12 V |
| Full 16:9 shoot and protect 14:9 | | 1110 | According to user preference. See Table 9 ^{b)} | | |
| Full 16:9 shoot and protect 4:3 | | 1111 | According to user preference. See Table 9 | | |

^{a)} Or 14:9 letter box if available.

^{b)} A 14:9 letter box is preferable to 16:9 letter box in this case.

Where the active_format code is a reserved value, or the active_format code is absent, the behaviour is as if the active_format code was 1000.

6.4.4.4.2 User preferences for displaying 16:9

Four user preferences for presentation of widescreen material are defined in Table 9. In the first three cases, the STB provides processing to format 16:9 video for 4:3 display. In the fourth case, the STB outputs the 16:9 format signal as if it was addressing a 16:9 display. This mode allows a 4:3 display with special features (such as letter box processing) to format the video to its aspect ratio.

Table 9 – User options for displaying 16:9 on 4:3

| Selected mode | Decoder format conversion | WSS codes for aspect ratio | Peritelevision connector Pin 8 |
|------------------|---------------------------|----------------------------|--------------------------------|
| 16:9 letter box | 16:9 LB | 1101 | 12 V |
| 14:9 letter box | 14:9 LB | 1000 | |
| Centre cut-out | CCO | 0001 | |
| Use TV's feature | FF | 1110 | 6 V |

6.4.4.4.3 User preferences for displaying >16:9

4 user preferences for presentation of "cinemascope" material (>16:9) are defined in Table 10. In the first three cases, the STB provides processing to format >16:9 video for 4:3 display. In the fourth case, the STB outputs the >16:9 format signal as if it was addressing a 16:9 display. This mode allows a 4:3 display with special features (such as letter box processing) to format the video to its aspect ratio.

Table 10 – User options for displaying >16:9 on 4:3

| Selected mode | Decoder format conversion | WSS codes for aspect ratio | Peritelevision connector pin 8 |
|---|---------------------------|-------------------------------------|--------------------------------|
| 16:9 letter box | 16:9 LB | 1011 (>16:9 LB centre) ^a | 12 V |
| 14:9 letter box | 14:9 LB | 1101 (16:9 LB centre) ^a | |
| Centre cut-out | CCO | 1000 (14:9 LB centre) ^a | |
| Use TV's feature | FF | 1110 ^b | 6 V |
| ^a The WSS code indicated in this cell probably corresponds to the number of active lines in the output signal of the STB for the material being processed. | | | |
| ^b EN 300 294 does not have a way to indicate the active area being less than full frame for the "16:9 anamorphic" mode. | | | |

6.4.4.4.4 Key

The tables in 6.4.4.4 and 6.4.4.5 use the following abbreviations:

FF Full frame

The output of the decoder is the full width and height of the coded frame.

LB Letter box

The coded frame is reduced to a 16:9 (or 14:9) letter box and presented within a 4:3 raster.

CCO Centre cut-out

The central 4:3 aspect ratio region of the 16:9 frame is extracted and output as a 4:3 raster.

6.4.4.4.5 WSS signalling with 4:3 display

Although 4:3 displays generally are not expected to respond to the aspect ratio information WSS codes (see Table 12), this signalling is provided to ensure correct behaviour if the video is recorded and then subsequently displayed on a TV that supports WSS.

6.4.4.5 STB with 16:9 display

Table 11 shows the response of a set top box to all broadcast format when connected to a 16:9 aspect ratio display via a peritelevision connector.

Table 11 – Processing by STB connected to 16:9 TV

| Broadcast format | | | STB into 16:9 display | | |
|--|-------------------|---------------|---------------------------|------------------|--------------------------------|
| Description of format | On-air signalling | | Decoder format conversion | Signalling to TV | |
| | MPEG | active_format | | WSS | Peritelevision connector Pin 8 |
| 16:9 letter box (top) | 4:3 | 0010 | FF | 0010 | 12 V |
| 14:9 letter box (top) | | 0011 | | 0100 | |
| >16:9 letter box | | 0100 | | 1011 | |
| 4:3 | | 1000 | | 0001 | |
| | | 1001 | | | |
| 16:9 letter box | | 1010 | | 1101 | |
| 14:9 letter box | | 1011 | | 1000 | |
| Full 4:3 shoot and protect 14:9 | | 1101 | | 0111 | |
| 16:9 letter box shoot and protect 14:9 | | 1110 | | 1101 | |
| 16:9 (with shoot and protect 4:3 centre) | | 1111 | | | |
| 16:9 | 16:9 | 0010 | FF | 1110 | 6 V |
| 14:9 pillar box | | 0011 | | | |
| >16:9 letter box | | 0100 | | | |
| 16:9 | | 1000 | CCO | 0001 | 12 V |
| 4:3 pillar box | | 1001 | FF | 1110 | 6 V |
| 16:9 | | 1010 | | | |
| 14:9 pillar box | | 1011 | | | |
| 4:3 pillar box shoot and protect 14:9 | | 1101 | CCO | 0111 | 12 V |
| Full 16:9 shoot and protect 14:9 | | 1110 | FF | 1110 | 6 V |
| Full 16:9 shoot and protect 4:3 | | 1111 | | | |

When the set top box and TV are connected via HDMI, the output of the set top box shall always be formatted for 16:9 display. See 6.4.4.7.4 for further information.

6.4.4.6 Integrated 16:9 TV

The response of an integrated 16:9 TV to the broadcast format described in 6.4 should be equivalent to the combined response of a set top box (see 6.4.4.5) and a 16:9 TV.

6.4.4.7 Wide screen signalling (WSS)

It is recommended to insert WSS according to EN 300 294/ITU-R BT.1119-2 into the analogue output signal.

6.4.4.7.1 Aspect ratio bits

The aspect ratio bits shall be set according to the previous clauses, with the following meaning (reproduced from EN 300 294/ITU-R BT.1119-2).

Table 12 – WSS codes for aspect ratio

| WSS code ^a bits 0-3 | Description |
|---|---|
| 0001 | Full format 4: 3 |
| 1000 | Box 14:9 centre |
| 0100 | Box 14:9 top |
| 1101 | Box 16:9 centre |
| 0010 | Box 16:9 top |
| 1011 | Box > 16:9 centre |
| 0111 | Full format 4:3 (shoot and protect 14:9 centre) |
| 1110 | Full format 16: 9 anamorphic |
| ^a This bit ordering follows the ETS specification (i.e. bslbf). The ITU specification writes the bits d_3 - d_0 . The specifications are identical as in both cases the transmission order is d_0 to d_3 . | |

6.4.4.7.2 Other WSS bits

The non-aspect ratio bits in the WSS signal (bits b_4 ... b_{13}) convey additional information. If WSS information is broadcast according to EN 301 775 (see 11.4), the values bits b_4 ... b_{13} from the broadcast signal can be copied from this information. If no such information is broadcast, the receiver shall set these bits to a meaningful value:

Table 13 – Values for other WSS bits

| WSS bit(s) | Value | Comment | |
|------------------------|---------------------------|---------|---|
| b_4 | Film mode | 0 | No information regarding field paring is available |
| b_5 | Colour coding | 0 | No motion adaptive colour plus |
| b_6 | Helper | 0 | No helper signal present |
| b_7 | Reserved | 0 | |
| b_8 | Subtitles within teletext | 0/1 | Set to 1 if DVB SI teletext descriptor with teletext_type=0x02 present |
| b_9 , b_{10} | Subtitling mode | 00 | If no DVB subtitling is inserted |
| | | 10/01 | If DVB subtitling is inserted, the receiver can deduce whether this subtitling information is placed in the active video part (WSS – see 11.4.2) and/or in the black bar part, and set these bits accordingly |
| b_{11} | Surround sound | 0/1 | Deduce from DVB SI component descriptor (and MPEG stream_type) |
| b_{12} , b_{13} | Copyright information | 00 | See Annex C of EN 300 294 (V1.4.1, 2003-04). Unless specified otherwise, the receiver shall set these bits to 0, 0, reflecting that the output signal of the receiver has no known copyright restrictions and copying is allowed. |

6.4.4.7.3 Additional temporal specification for WSS outputs

If WSS is inserted:

- the WSS shall first be output in line 23 of the first frame to which it applies;
- the same WSS status bits shall be transmitted in each subsequent frame until the video format changes.

6.4.4.7.4 AFD processing for HDMI output

Receivers with HDMI output are recommended to provide at least one of the following methods to process aspect ratio and AFD information for video output on HDMI:

- provide a reformatting function for the video to match the aspect ratio of the display based on AFD, aspect ratio and user preference as per 6.4.4.5 (for 16:9 displays). Support for scaling to 4:3 aspect ratio for HDMI is optional (since consumer HD displays are 16:9). Aspect ratio signalling in the HDMI AVI Infoframe bits R0..R3, M0, M1 (see CEA 861) shall be set in accordance with the properties of the video on the output;
- pass the video to the HDMI output unprocessed with respect to AFD and aspect ratio scaling, and pass AFD and aspect-ratio signalling in the video to the HDMI output as part of the AVI Infoframe bits R0..R3, M0, M1 (see CEA 861).

6.5 Recommendations for ISO/IEC 13818-1 signalling

As described in TS 101 154 the target background grid descriptor and video window descriptor may be used within broadcasts to position the video output for standard definition video streams within a 720×576 display grid or for high definition video streams within a 1280×720 display grid or a 1920×1080 display grid.

In addition to this, the position of the video output within the display shall be restricted to even (chroma) pixel and even (field) line ordinates.

6.6 Alignment of SD video and graphics

6.6.1 Video with graphics

The graphics system used by subtitling addresses a 720×576 pixel space. The output of the MPEG video decoder shall be centred vertically and horizontally within this space after upsampling (see Figure 2).

If the result of the upsampling process is less than 720 pixels wide then the output of the video decoder shall be centred within the region of 720 active digital video pixels. Also, centring should be used to position the video decoder output vertically within the 576 active lines of the analogue display.

If the result of the upsampling process is greater than 720 pixels wide then the output of the video decoder shall be cropped symmetrically to fit within the region of 720 active video pixels.

6.6.2 Uncertainty of position of graphics over video

For some transmission modes, (those labelled with “According to user preference” in Table 8), the user is free to choose the processing in the block “Decoder Format Conversion” in Figure 2.

Since the insertion of graphics (for example subtitles) is performed after this block, such a choice will influence the positioning of graphics relative to the video signal, as made apparent by the following example (illustrated in Figure 4):

Consider a broadcast of 16:9 material with subtitles (top row in the figure) and three viewers, one with a 16:9 set and two with 4:3 sets. The viewer with the 16:9 set sees the entire video frame (the second row in the figure). The first 4:3 viewer has selected the “centre cut out” mode (the third row), while the second 4:3 viewer has selected the “letterbox” mode (the fourth row).

As becomes apparent from the figure, the area of video obscured by the subtitles is different for each of these viewing modes.

Broadcasters shall be aware of this uncertainty.

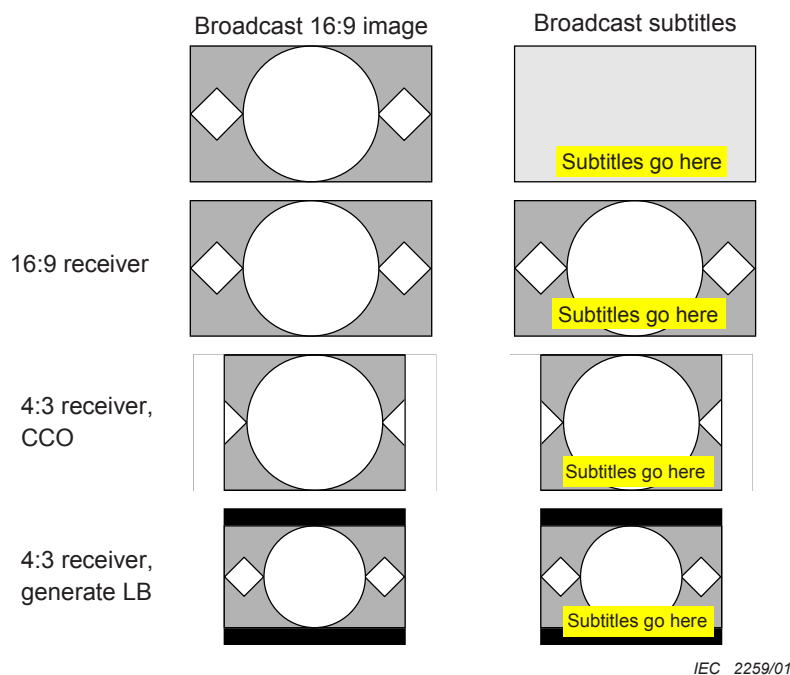

Figure 4 – Uncertainty of positioning graphics over video

6.7 Alignment of HD video and graphics

The graphics system used by the subtitling addresses either a 720×576 , 1280×720 or 1920×1080 pixel space, depending upon the receiver capabilities and the parameters in the display definition segment. The output of the MPEG video decoder is centred vertically and horizontally within a pixel space of 1280×720 or 1920×1080 after upsampling, in a similar manner to that described in 6.6.1. The graphics pixel space does not necessarily match that of the video decoder and it is the role of the receiver to scale one or both of these so that they are the same resolution before output. In this scaling, the graphics plane shall be scaled so that it totally covers the video plane (i.e. the top left hand corner of the video plane corresponds with the top left hand corner of the graphics plane, and similarly for the bottom right corners).

7 Audio system characteristics

7.1 General

This clause, based on the D-Book version 3.0, defines the digital audio encoding standards that shall be used in all broadcasts.

7.2 Essential requirements

When the video is encoded to ISO/IEC 13818-2 SD, at least one audio component of the broadcast shall be encoded according to ISO/IEC 13818-3. All receivers shall be able to meet the minimum decoding requirements set out in the 'MPEG-1 and MPEG-2 backward compatible audio' clause of TS 101 154.

Where the video is encoded to ISO/IEC 14496-10, the audio components shall be encoded according to ISO/IEC 13818-3, TS 102 366 (AC-3 or Enhanced AC-3) or ISO/IEC 14496-3 (MPEG-4 High Efficiency AAC, but excluding the use of the Parametric Stereo tool). Advanced receivers shall be able to meet the minimum decoding requirements set out in

either the 'AC-3 and Enhanced AC-3 audio' clause or the 'MPEG-4 AAC, MPEG-4 HE-AAC and MPEG-4 HE-AACv2 audio' clause, excluding MPEG-4 HE-AACv2, of TS 101 154³.

In all cases, the audio shall be constrained according to TS 101 154 with a maximum of 5.1 channels per component.

When an audio stream is provided that is intended to be decoded in addition to the main audio and mixed with it, it shall be constrained⁴ according to TS 101 154 Annex E⁵.

7.2.1 Requirements

The requirements in 7.2 on audio signals apply to applications including, but not limited to, those listed below:

- primary and other language audio channels for television programmes;
- audio only 'radio' services;
- audio description (for the visually impaired);
- clean dialogue (for the hearing impaired).

7.2.2 Synchronisation

The A/V synchronisation in broadcast signals shall be according to ITU-R BT.1359-1.

Receivers are recommended not to introduce more than ± 5 ms relative delay between the video and any audio component (relative to the times indicated by their respective PTSs).

NOTE Set top boxes are not required to accommodate any additional relative delay introduced by the TV that presents the signal to the user.

Where additional independent audio components are decoded from the same service (for example normal programme audio and audio description or normal programme and clean commentary) receivers should not introduce more than ± 5 ms of relative delay between the audio components.

7.2.3 Audio metadata

All streams shall contain such metadata that is necessary to allow a receiver to perform the following:

- normalise the level of the audio between services;
- downmix any multichannel audio to stereo;
- mix any secondary decoded audio stream with the main decoded audio stream.

7.2.4 Decoding requirements

All receivers shall provide at least one audio decoder able to meet the minimum decoding requirements set out in above. Preferably receivers should implement more than one audio decoder to enable, for example, the concurrent decoding of both the normal audio and the audio description for a television programme. See 7.4.2.

³ Advanced receivers will therefore decode the MPEG-4 HE-AAC part of the MPEG-4 HE-AACv2 stream as a mono track.

⁴ Within the scope of this standard, the transmission part of TS 101 154, Annex E is mandatory.

⁵ It is expected that a new version of TS 101 154 will be released shortly that will cover the application of audio description to audio encodings other than ISO/IEC 13818-3.

7.3 Constraints and extensions

7.3.1 Digitally coded

Surround sound may optionally be provided as a digital multichannel audio service component, thereby giving freedom of artistic exploitation to the programme makers. The allocation of channels, particularly for a 5.1 digital multichannel service is given in ITU-R BS.775-2.

Multichannel audio streams shall be limited to a maximum of 5.1 channels.

7.3.2 Surround sound

Multichannel audio signals may optionally be matrixed onto suitably coded MPEG audio stereo signals to generate a service which can be decoded using surround sound decoders. Provision of surround sound decoders in receivers is optional.

7.3.3 AC-3 and Enhanced AC-3 audio

7.3.3.1 General

This standard allows AC-3 or Enhanced AC-3 audio to be transmitted in accordance with TS 102 366, EN 300 468 and TS 101 154. Receivers conforming to this standard should provide a method to make the AC-3 audio available to the user.

7.3.3.2 Broadcast specifications

7.3.3.2.1 Carriage

AC-3 or Enhanced AC-3 broadcasts, if any, shall be in accordance with TS 102 366, EN 300 468 and TS 101 154. The service information for (Enhanced) AC-3 streams carried in DVB systems shall be as defined in EN 300 468, Annex D. The carriage of (Enhanced) AC-3 elementary streams as private data within MPEG systems is described in the 'Audio' clause of TS 101 154.

7.3.3.2.2 Signalling

AC-3 or Enhanced AC-3 streams shall be signalled in the Program Map Table using stream type 0x06 indicating PES packet private data. See also TS 102 366.

The AC-3 descriptor or Enhanced AC-3 descriptor, as appropriate, defined in the DVB SI specification EN 300 468, Annex D shall be placed in the elementary stream (2nd) loop of the PMT.

7.3.3.2.3 Recommendation

It is recommended that broadcasts only provide AC-3 or Enhanced AC-3 streams where the decoded audio stream is a so-called 'full service' (suitable for decoding and presentation to the listener), as opposed to (Enhanced) AC-3 streams where the decoded audio stream is intended to be combined with another decoded audio stream before presentation to the listener.

7.3.3.3 Receiver functions

It is optional for a standard receiver to implement any AC-3 or Enhanced AC-3 support. If either is supported, it is sufficient to support only one (Enhanced) AC-3 stream (as opposed to having capabilities of combining more streams into one before representing to the user).

If AC-3 or Enhanced AC-3 is supported, the receiver shall support sample rates up to 48 kHz.

7.3.4 ISO/IEC 14496-3 audio

7.3.4.1 General

This standard allows ISO/IEC 14496-3 audio to be transmitted in accordance with EN 300 468 and TS 101 154 but excludes the use of the Parametric Stereo tool (i.e. MPEG-4 HE-AACv2 is not allowed). Advanced receivers conforming to this standard should provide a method to make the ISO/IEC 14496-3 audio available to the user.

7.3.4.2 Broadcast specifications

7.3.4.2.1 Carriage

ISO/IEC 14496-3 broadcasts, if any, shall be in accordance with EN 300 468 and TS 101 154 (up to HE-AAC level 2 for stereo or level 4 for multi-channel (maximum 5.1 channels)). The service information requirements for ISO/IEC 14496-3 streams carried in DVB systems are described in EN 300 468, Annex H.

7.3.4.2.2 Signalling

The AAC descriptor defined in the DVB SI specification EN 300 468, Annex H shall be placed in the elementary stream (2nd) loop of the PMT.

7.3.5 Receiver downmix

Advanced receivers shall be able to downmix a surround sound audio stream, however encoded, to PCM stereo for use where required, for example for output to stereo speakers or on HDMI. For this purpose, they shall use the appropriate metadata in the audio stream as defined in ISO/IEC 14496-3, 4.6.8.3 or TS 102 366, 6.8, as appropriate.

If an output for surround sound audio is provided by the receiver (e.g. SPDIF), it shall be possible for the user to set this output to carry the downmixed audio instead.

7.3.6 Digital audio output

A receiver may have a digital audio output, either via HDMI or via an optical or coaxial SPDIF connector. If such an output exists on a receiver, it shall be capable of carrying at least:

- a) two channel PCM in case of MPEG1-layerII format or any other format audio codec reception;
- b) the original AC-3 bitstream in case AC-3 is supported and being received;
- c) an AC-3 transcoded bitstream in case Enhanced AC-3 is supported and being received;

whereby:

- 1) a transcoded bitstream shall have the same channel layout as the originally received bitstream unless when exceeding the maximum number of channels supported by the transcoded bitstream format, in which case this maximum shall be used, and
- 2) in case ISO/IEC 14496-3 audio is supported, receivers shall support downmix to stereo (as per a) above), and are recommended to support transcoding to DTS or AC-3.

7.4 Audio description

7.4.1 Background

Audio description is an “ancillary service” primarily provided for the visually impaired. It provides a spoken description of the video component of a service.

NOTE Provision of audio description for a proportion of programmes is a licence requirement for digital terrestrial broadcasts in the UK.

Description content is voice only and may be conveyed in one of two ways: receiver mix AD or broadcast mix AD. For receiver mix AD, the spoken description is broadcast as a separate coded mono audio stream. In this case, the receiver decodes the main programme and the description streams and combines the decoded signals as described below. For broadcast mix AD, these streams are mixed by the broadcaster and broadcast as an alternative main programme stream. The user has no control over the relative levels of the primary audio and the spoken description.

Individual AD users will have different aural acuity, different describers will have their own style of vocal delivery (voice pitch and timbre), several voices may be used to describe a single programme and there are, in practice, differences in audio signal level for different home receivers. Loud sound effects or accompanying music can make any description hard to discern. A key requirement of the AD decoder when handling receiver mix AD is therefore to allow the relative level of programme sound in the mix to be adjusted on a description passage-by-passage basis. The programme maker is best able to determine a suitable default relative level under controlled conditions when the AD component is being authored so suitable “fade” information is transmitted with the description stream.

Description is typically confined to gaps in the programme narrative. Some programmes (and genres) are more suited to description than others; one programme may be effectively self-describing whilst another (e.g. a news programme or studio interview) might actually offer no opportunities for descriptive interpolation. AD receivers should therefore provide the user with a means of confirming that, in what may be extended gaps between description passages, description silence does not necessarily imply failure in delivery of the service or in the receiving equipment.

7.4.2 Receiver implementation minima

Receivers are recommended to provide at least one method to deliver audio description to viewers.

The preferred method is to decode receiver mix AD by providing two audio decoders, as illustrated in Figure 5.

7.4.3 Receiver mix AD signalling

This subclause is principally concerned with the signalling used to implement the programme provider control of programme volume. Other controls, and the method for presentation of the “described” and/or “standard” sound outputs are addressed for information below. If the audio is encoded according to TS 102 366, the mixing metadata may alternatively be provided by the means described in that specification.

7.4.3.1 Level control

Three contributions to the “described” output sound level can be identified. These are illustrated in Figure 5.

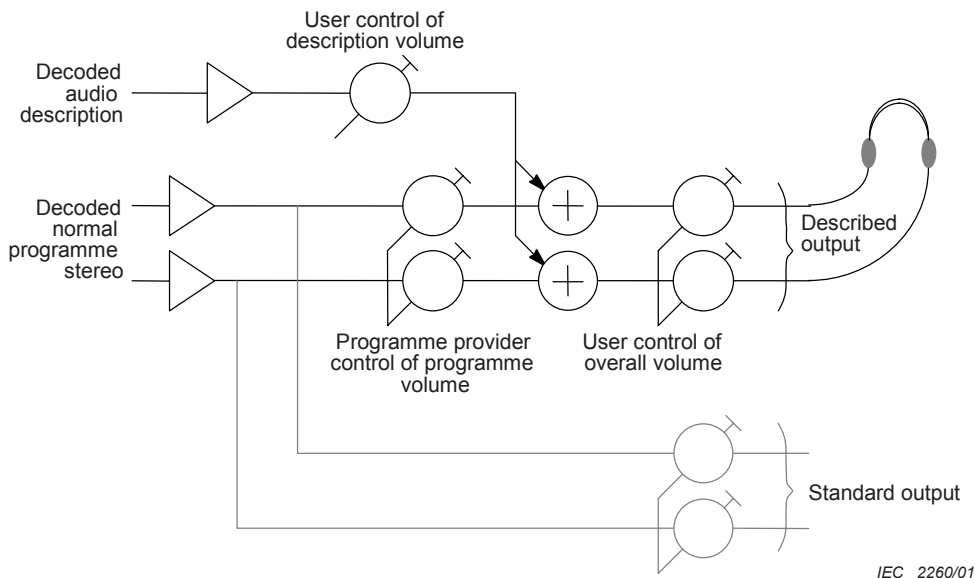

Figure 5 – Illustration of control of audio level

7.4.3.2 Placement control

Signalling is provided to allow the broadcaster to place the “describer” at any preferred horizontal position within the sound field (speech from out-of-vision commentators is often placed to one side in the stereo image).

7.4.3.3 Syntax and semantics

Audio description streams shall carry the audio description descriptor defined in Table 14 in their PES_private_data field of the PES packet header.

Table 14 – Audio description descriptor

| Syntax | Value | Data | Comment |
|----------------------|-------------------|----------|---------------|
| AD_descriptor() { | | | |
| reserved | 1111 | 4 bslbf | |
| AD_descriptor_length | 1000 | 4 bslbf | |
| AD_text_tag | 0x4454474144 | 40 bslbf | 6 byte string |
| AD_revision_tag | 0x01 | 8 bslbf | |
| AD_fade_byte | 0xYY | 8 bslbf | FADE byte |
| AD_pan_byte | 0xYY | 8 bslbf | PAN byte |
| reserved | 0xFFFFFFFFFFFFFFF | 56 bslbf | |
| } | | | |

7.4.3.3.1 AD_descriptor_length

The descriptor length gives the number of significant bytes following the length field (i.e. 8).

7.4.3.3.2 AD_text_tag

The tag is a 5 character string of ASCII characters as a simple and unambiguous means of distinguishing this from any other PES_private_data.

If a receiver does not recognise this tag, it should ignore the audio description stream carrying it.

7.4.3.3.3 AD_revision_tag

The tag is extended by a 1 byte version designator.

Descriptors with the same text tag (0x4454474144) but a higher revision tag shall be backwards compatible with this standard, i.e. the syntax and semantics of the fade and pan byte fields will be identical but additionally some of the reserved bytes may be used for new signalling.

Receivers recognising the main text tag but an earlier revision (lower tag value) should decode the stream based on the fields of the descriptor that it understands and should ignore any additional parameters.

7.4.3.3.4 AD_fade_byte

The fade byte takes values between 0x00, representing no fade of the normal programme sound, and 0xFF, representing no normal programme sound.

Over the range 0x00 to 0xFE one lsb of this field represents an attenuation step of approximately 0,3 dB giving a range of about 77 dB. 0xFF represents no normal programme sound.

7.4.3.3.5 AD_pan_byte

The pan byte takes values between 0x00, representing a central forward presentation of the audio description, and 0xFF, each increment representing a $360/256$ degree ($\sim 1,4^\circ$) step clockwise looking down on the listener. See Figure 6.

7.4.3.3.6 Reserved

The remaining 7 bytes of the PES_private_data field are set to 0xFF and reserved for future use.

7.4.3.4 Example

When including this descriptor in an audio stream PES-packet, the PES-packet header syntax will be as shown in Table 15.

Table 15 – Illustration of PES packet header

| Syntax | Value | Data | Comment |
|--------------------------------------|------------------|-----------|--------------------|
| Packet_start_code_prefix | 0x000001 | 24 bslbf | |
| stream_id | 0xYY | 8 uimsbf | Actually '110ZZZZ' |
| PES_packet_length | 0xYYYY | 16 uimsbf | As appropriate |
| '10' | 10 | 2 bslbf | |
| PES_scrambling_control | YY | 2 bslbf | As appropriate |
| PES_priority | Y | 1 bslbf | |
| data_alignment_indicator | Y | 1 bslbf | |
| copyright | Y | 1 bslbf | |
| original_or_copy | Y | 1 bslbf | |
| PTS_DTS_flags | 10 | 2 bslbf | If PTS present |
| ESCR_flag | 0 | 1 bslbf | |
| ES_rate_flag | Y | 1 bslbf | As appropriate |
| DSM_trick_mode_flag | 0 | 1 bslbf | |
| additional_copy_info_flag | 0 | 1 bslbf | |
| PES_CRC_flag | Y | 1 bslbf | As appropriate |
| PES_extension_flag | 1 | 1 bslbf | |
| PES_header_data_length | 0xYY | 8 uimsbf | As appropriate |
| '0010' | 0010 | 4 bslbf | |
| PTS[32..30] | YYY | 3 bslbf | As appropriate |
| '1' | 1 | 1 bslbf | |
| PTS[29..15] | YYYYYYYYYYYYYYYY | 15 bslbf | As appropriate |
| '1' | 1 | 1 bslbf | |
| PTS[14..0] | YYYYYYYYYYYYYYYY | 15 bslbf | As appropriate |
| '1' | 1 | 1 bslbf | |
| if (ES_rate_flag == '1') {etc.} | | | |
| if (PES_CRC_flag == '1') {etc.} | | | |
| PES_private_data_flag | 1 | 1 bslbf | |
| pack_header_field_flag | 0 | 1 bslbf | |
| program_packet_sequence_counter_flag | 0 | 1 bslbf | |
| P-STD_buffer_flag | 0 | 1 bslbf | |
| reserved | 111 | 3 bslbf | |
| PES_extension_flag_2 | 0 | 1 bslbf | |
| AD_descriptor(){ | | | |
| reserved | 1111 | 4 bslbf | |
| AD_descriptor_length | 1000 | 4 bslbf | In version 1 |
| AD_text_tag | 0x4454474144 | 40 bslbf | 6 byte string |
| AD_revision_tag | 0x01 | 8 bslbf | |
| AD_fade_byte | 0xYY | 8 bslbf | FADE byte |
| AD_pan_byte | 0xYY | 8 bslbf | PAN byte |
| reserved | 0xFFFFFFFFFFFFFF | 56 bslbf | |
| } | | | |
| for (i=0; i<N1; i++) { | | | |
| stuffing_byte | | | If required |
| } | | | |
| // and now follows the PES data // | | | |

7.4.3.5 Interpretation of pan information

The definition of “pan” is compatible with future systems that might employ digital multi-channel surround sound for normal programme audio. Where the normal programme audio is stereo, the range of values for “pan” are limited to the interval 0xEB...0x00...0x15.

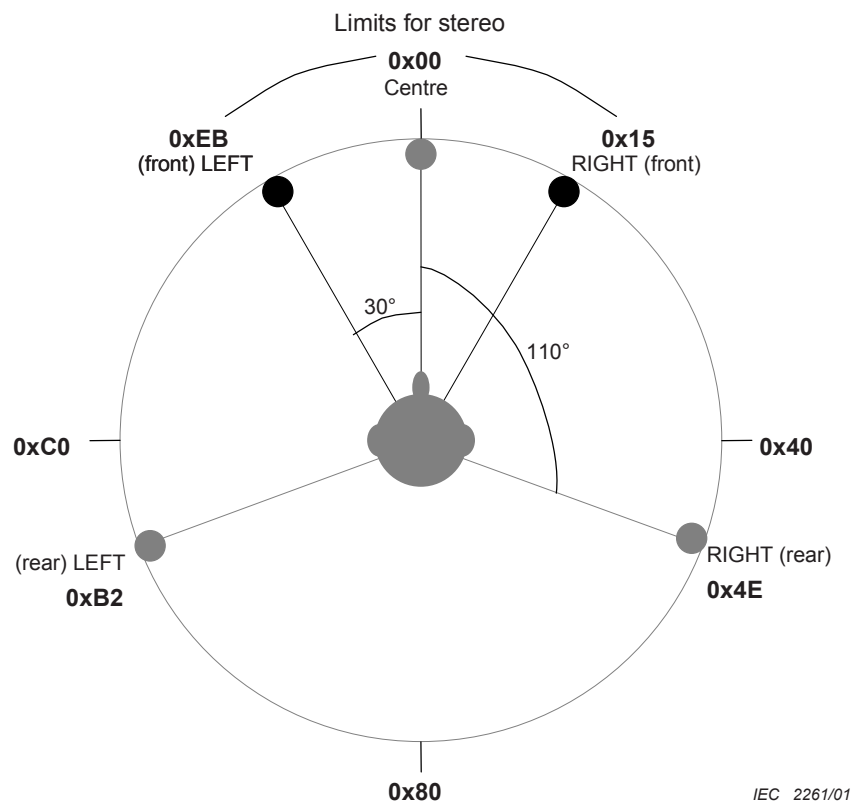

Figure 6 – Mapping of pan byte onto sound presentation

7.4.3.6 Signalling rate of fade and pan information

The maximum rate of signalling of fade and pan values is determined by the number of audio PES packets per second for that AD stream. For efficiency, several access units of audio are typically encapsulated within one PES packet and the fade and pan values in each AD_descriptor are deemed to apply to each of the complete access units (AUs) encapsulated within, and which commence in, that PES packet.

In practice, the encapsulation of several AUs within one PES packet means that fade and pan values are transmitted typically every 120 ms to 200 ms. This allows the programme provider to have some control over the attack and decay of a fade and for fades to be reasonably gentle (i.e. taking several intermediate values between no-fade and the final target) where a gap in the narrative permits.

7.4.4 Constraints on audio description stream coding

The audio description stream for receiver mixing shall comply with TS 101 154 constrained as follows:

- the description shall have the same audio sampling frequency and encoding format as the main programme sound for that service;
- it shall be encoded as mono audio.

7.4.5 Receiver mix AD implementation notes

7.4.5.1 Default states and error conditions

Unless signalling in a selected audio description stream indicates otherwise, the normal programme audio should be output without attenuation.

Receivers may ignore the pan information, but if they do so they must position the audio description centrally (i.e. as if pan byte = 0x00).

7.4.5.2 Decoder behaviour in the presence of AD

In the presence of a valid AD descriptor in the description stream of the selected service, the AD decoder should present the appropriate mix of decoded programme sound and description signal to the user. The AD decoder should then attenuate the programme sound by 0,3 dB per fade value increment.

When the fade value is 0x00 (or in the absence of an AD stream) the programme sound level should be unattenuated. Care should be taken to ensure that the default levels of programme sound and description are consistent when fed with streams coding standard level signals. It is also important that the mono description is matrixed to the stereo output so as to achieve a constant perceived description volume as the description is panned from stereo left through stereo centre to stereo right (e.g. using a model based on constant power as the description is panned across the stereo sound stage).

In a stereo environment, the AD decoder should interpret any pan values outside the ranges 0xEB..0xFF and 0x00..0x15 in the following manner. Pan values from 0x16 to 0x7F inclusive should be mapped to the value 0x15 (i.e. stereo hard right). Pan values from 0x80 to 0xEA should be mapped to the value 0xEB (i.e. stereo hard left).

If, whilst listening to a described programme, the user selects a new programme, the AD decoder should mute the decoded description signal and restore the programme sound to the unfaded state. This restoration should not be abrupt - it is recommended that under such conditions the value of fade and of pan are ramped to the default values (0x00) over a period of at least 1 s.

AD decoders should be capable of decoding MPEG1 layer II or MPEG2 mono signals at bitrates between 64 kbits/s and 256 kbits/s and of supporting 32 kHz and 48 kHz audio sampling rates. AD decoders should also be capable of decoding HE-AAC and Enhanced AC-3 mono signals.

AD decoder implementations may usefully include separate hi-fi and VCR outputs and provide an output for headphones should the AD user wish to listen in the company of others who do not wish to hear the description. AD decoders should present to their VCR output a mix of programme sound and description modulated as appropriate by fade and pan but before any attenuation applied by the user control of overall volume control, shown diagrammatically in Figure 5 above.

7.4.5.3 Decoder behaviour in the presence of errors

If the AD decoder detects an error in, or absence of, the AD descriptor in the encoded AD signal, it should have a strategy which leads to muting the decoded description signal, restoring the programme sound to its default unfaded amplitude and setting the effective fade and pan values to 0x00 (e.g. the AD decoder might flywheel through isolated errors caused by occasional uncorrected transmission errors but should respond appropriately to successive instances of loss).

Whenever the AD signal is suddenly lost or regained, the AD decoder behaviour as experienced by the user should never be abrupt. It is recommended that in the event of an error or the absence of AD signal, the value of fade and of pan implemented by the AD decoder be ramped from the signalled values to the default values (0x00) over a period of at least 1 s. Equally, on recovery from an error or on the reappearance of the AD signal the value of fade and of pan should be ramped to the signalled values from the default values (0x00) over a similar period.

7.4.5.4 Time of application

All PES packets conveying audio description audio streams shall include an audio description descriptor. The value of fade and pan byte in any PES packet shall apply to all access units commencing within that PES packet.

7.4.5.4.1 Error resilience

If due to some fault or error condition the audio description descriptor is absent or recognisably corrupted, the receiver should revert to the default state (fade = 0x00, pan = 0x00) after a suitable delay.

7.4.5.4.2 Attack and decay

Values for “fade” will be transmitted 5 to 10 times per second. This allows the service provider to signal gradual changes of “fade”. Receivers should not implement any additional time constants.

7.4.5.5 Approximation of pan and fade

7.4.5.5.1 Pan

Panning is typically implemented by reducing the level of description in the left- or the right-hand audio output signals only; description in the other signal is not attenuated. A suitable pan characteristic can be obtained by attenuating the left or right contribution at the rate of 1 dB per pan increment. Thus a pan value of 0x08 results in an attenuation of 8 dB of the description component in the left output. If the AD decoder cannot support 1,4 degree steps in the implemented pan then the implemented pan should match the intended pan as closely as possible.

7.4.5.5.2 Fade

A description signal at reference level (as recommended in TS 101 154) should appear in the mixed output also at reference level in both the left- and the right-hand audio output signals when both signalled fade and pan values are zero and the user controls are at their default settings. If the AD decoder cannot support 0,3 dB steps in implemented fade then the implemented attenuation should match the intended attenuation as closely as possible. For example if only 1 dB steps are possible then fade values of 0x00 and 0x01 should map to 0 dB, 0x02, 0x03 and 0x04 should map to -1 dB, 0x05, 0x06, 0x07 & 0x08 to -2 dB etc.

7.4.5.6 Equalisation of delays

In certain implementations, for example where the audio description AND normal programme audio are decoded and mixed by an in decoder addition to the normal decoder of the receiver, the listener may be exposed to normal programme audio from two different decoders. It is desirable to minimise or prevent exposing the listener to differential delays of this kind.

7.4.6 SI/PSI signalling

7.4.6.1 Receiver mix AD

7.4.6.1.1 PSI signalling

The normal programme audio stream and the audio description stream shall be distinguished by signalling in the PSI program map table (PMT). In the ISO_639_language_descriptor for normal programme sound, the value of the audio_type field shall be 0x00 (undefined). In the ISO_639_language_descriptor for audio description, the value of the audio_type field shall be 0x03 (visually impaired commentary). The stream_type and ISO_639_language_code fields for the two streams shall be the same.

This is illustrated below in a real example from a DTT PMT.

| <code>// main programme audio details</code> | | |
|--|---------------------|---|
| <code>{</code> | | |
| <code> stream_type</code> | <code>0x03</code> | <code>; Audio MPEG1</code> |
| <code> reserved</code> | <code>111b</code> | |
| <code> elementary_PID</code> | <code>0x0259</code> | <code>; PID for programme sound</code> |
| <code> reserved</code> | <code>1111b</code> | |
| <code> ES_info_length</code> | <code>0x009</code> | |
| <code> {</code> | | |
| <code> descriptor_tag</code> | <code>0x52</code> | <code>; stream identifier descriptor</code> |
| <code> descriptor_length</code> | <code>0x01</code> | |
| <code> component_tag</code> | <code>0x02</code> | |
| <code> }</code> | | |
| <code> {</code> | | |
| <code> descriptor_tag</code> | <code>0x0A</code> | <code>; ISO 639 language descriptor</code> |
| <code> descriptor_length</code> | <code>0x04</code> | |
| <code> ISO_639_language_code</code> | <code>"eng"</code> | <code>; English</code> |
| <code> audio_type</code> | <code>0x00</code> | <code>; undefined</code> |
| <code> }</code> | | |
| <code>}</code> | | |

Figure 7 – Example of PMT extract for main programme audio

| <code>// audio description details</code> | | |
|---|---------------------|---|
| <code>{</code> | | |
| <code> stream_type</code> | <code>0x03</code> | <code>; Audio MPEG1</code> |
| <code> reserved</code> | <code>111b</code> | |
| <code> elementary_PID</code> | <code>0x025A</code> | <code>; PID for audio description</code> |
| <code> reserved</code> | <code>1111b</code> | |
| <code> ES_info_length</code> | <code>0x009</code> | |
| <code> {</code> | | |
| <code> descriptor_tag</code> | <code>0x52</code> | <code>; stream identifier descriptor</code> |
| <code> descriptor_length</code> | <code>0x01</code> | |
| <code> component_tag</code> | <code>0x03</code> | |
| <code> }</code> | | |
| <code> {</code> | | |
| <code> descriptor_tag</code> | <code>0x0A</code> | <code>; ISO 639 language descriptor</code> |
| <code> descriptor_length</code> | <code>0x04</code> | |
| <code> ISO_639_language_code</code> | <code>"eng"</code> | <code>; English</code> |
| <code> audio_type</code> | <code>0x03</code> | <code>; visual impaired commentary</code> |
| <code> }</code> | | |
| <code>}</code> | | |

Figure 8 – Example of PMT extract for audio description

If a service has AD in several languages, the PMT reference to each stream will have the appropriate `ISO_639_language_code` and the AD decoder should discriminate between them on the basis of the preferred language chosen in the user settings.

7.4.6.1.2 SI signaling

The EIT (present/following and schedule, if present) should contain a component descriptor (see 9.2.8.1) for the AD stream. The `stream_content` and `component_type` values shall be set to the following values (as per EN 300 468):

- 0x02 and 0x40 for MPEG-1 Layer 2 encoding;
- 0x06 and 0x40 for HE-AAC encoding;
- 0x04 and 0x90 for Enhanced AC-3 encoding.

In the case where the main audio is AC-3 encoded, the audio description shall be encoded according to Enhanced AC-3, in accordance with TS 102 366.

7.4.6.2 Broadcast mix AD

7.4.6.2.1 PSI signalling

The broadcast mix audio description stream shall be signaled as an alternative main audio stream distinguished from other audio streams by the language code. This shall be set to any legal language⁶ with the actual language provided in the supplementary_audio descriptor (see EN 300 468) in the PMT. In this descriptor, the mix_type shall be set to '1' and the editorial_classification shall be set to 'audio description for the visually impaired'. This allows multiple AD streams to be broadcast in a backwards compatible manner. The audio_type in the PMT shall be set to 0x00.

7.4.6.2.2 SI signaling

The EIT (present/following and schedule, if present) should contain a component descriptor (see 9.2.8.1) for the AD stream. The stream_content and component_type values shall be set to the following values (as per EN 300 468):

- 0x02 and 0x40 for MPEG-1 Layer 2 encoding;
- 0x06 and 0x40 for HE-AAC encoding;
- 0x04 and 0b01010xxx for AC-3 encoding (where xxx is dependent upon the number of channels, as per Annex D of EN 300 468);
- 0x04 and 0b11010xxx for Enhanced AC-3 encoding (where xxx is dependent upon the number of channels, as per Annex D of EN 300 468).

7.5 Audio only services

It is recommended that if a service only contains an audio component, the receiver should display a banner to indicate the programme or service name.

NOTE However, receivers in "radio mode" may have no functioning display so SI messages such as this may not be presented to the user.

8 Multiplex and transport stream characteristics

8.1 Scope

This clause, based on the D-Book version 3.0, defines the transport stream standards that shall be used in all broadcasts.

8.2 Essential requirements

8.2.1 Multiplexing

The multiplexing of baseband signals and associated data conforms to ISO/IEC 13818-1 constrained according to TS 101 154.

The PID and section filtering requirements for all broadcasts shall be such that they can be received by receivers meeting the requirements set out below.

⁶ The suggested language code to use is "qad" or any other language code deemed locally appropriate for this purpose.

8.2.1.1 Multiplex flexing

Broadcasts may instantaneously alter the bit rate allocated to program components or services provided that at all times the multiplex, and the streams within it, continue to comply with the buffer models defined for them in ISO/IEC 13818-1, ISO/IEC 13818-2, ISO/IEC 13818-3, ISO/IEC 14496-3, ISO/IEC 14496-10 and TS 102 366.

NOTE This enables the dynamic allocation of capacity between elementary streams within the transport multiplex. This allows the broadcaster freedom to trade technical quality and quantity of programme services within a multiplex or to use instantaneous “statistical multiplexing” to allow the best use of capacity between multiple programme services by varying the bit-rate occupied by any programme elementary stream to suit instantaneous demand.

8.2.2 Demultiplexing

All receivers shall be able to meet the minimum demultiplexing requirements set out in TS 101 154.

8.2.2.1 Data rates

A receiver should be able to demultiplex ISO/IEC 13818-1 transport streams with data rates of at least 58 Mbit/s.

NOTE While the theoretical maximum payload supported by the DVB terrestrial specification is 31,67 Mbit/s, receivers may include the capability to accept transport streams which have higher rates, via other means.

8.2.2.2 Errors

Receivers shall implement a suitable error concealment or error recovery mechanism on receipt of transport packet errors.

8.2.2.3 PID filters

Receivers shall be able to demultiplex at least 32 different PIDs simultaneously in order to receive any single service.

8.2.2.4 Section filters

Receivers shall be able to implement at least 32 simultaneous section filters, each applying a filter specification to bytes 1 and 4 to 10 of the section, where each bit in the filter is individually maskable. It shall be possible to apply all 32 section filters to each section.

8.2.2.5 Burst rate

The throughput of each PID/section filter shall be at least 5 Mbps (peak burst rate measured over 1 ms).

8.2.2.6 Scrambling control bits

The receiver shall respond appropriately to the DVB use of the transport scrambling control bits defined in ETR 289.

8.3 Constraints and extensions

8.3.1 Multicomponent programs

8.3.1.1 Compatible views

Where the PMT carries more than one audio or video elementary stream for a program they shall provide alternative, but compatible, “views” of a single event. For “simple” receivers this

presents the viewer with a choice. However, future receivers may have the ability to decode more than one video or audio component for simultaneous presentation to the viewer.

8.3.1.2 Incompatible views

Where a broadcaster wishes to present an “incompatible” viewing alternative this shall be done as separate programs/services, not as alternative “views” within a single program.

8.3.1.3 Ordering the PMT

The ordering of elementary streams within the PMT is not significant. The selection of an appropriate set of components from a program is facilitated by descriptors in the PMT and the EIT.

9 Service and program specific information

9.1 General

This clause covers the following topics:

- SI and PSI specification:
summarises the requirements on the signalling transmitted by the broadcaster and how the receiver should respond;
- receiver functions:
describes the essential features that all receivers shall provide to give users effective access to the broadcast services considered in this standard;
- establishing and maintaining the network connection:
describes how a receiver should understand the broadcast signalling when:
 - first connecting to a network, and when,
 - the characteristics of the network change;
- user interface:
provides recommendations and ideas to receiver manufacturers on what SI information to present to users and how to present it.

9.1.1 General requirements

Adherence to the DVB SI specification EN 300 468 and the guidelines for its use TR 101 211 and on the MPEG systems specification ISO/IEC 13818-1 and the DVB guidelines for its use TS 101 154.

9.1.2 General receiver requirements

9.1.2.1 Mandatory signalling

Certain of the SI and PSI are designated as “mandatory to interpret”. This indicates signalling that it is essential for the receiver to decode and interpret in order to be able to operate correctly.

9.1.2.2 Unrecognised signalling

Receivers should skip parts of the signalling that they do not “understand”. The objective of this policy is to enable receivers to continue operating under signals from future versions of this standard or where signals compatible with a version of this standard are extended in a compatible private way.

In particular:

- receivers shall skip unrecognised descriptors;
- receivers shall skip unrecognised user or private fields in public descriptors;
- receivers shall skip any unexpected additional payload in descriptors that they recognise (i.e. where the length of a descriptor is longer than they expect, they shall skip any bytes after the expected length).

9.1.2.3 Private extensions to DVB signalling

Receivers may interpret descriptors with a tag of 0x80-0xFE designated by DVB as “user defined” according to this standard.

It should be noted that this standard defines a number of such descriptors: see 9.2.11. DVB “user defined” descriptors, or descriptors carrying DVB-designated “private data”, rely on a preceding specific “private_data_specifier_descriptor” (not carrying the “EACEM PDSD”) in networks for their correct interpretation. These are unlikely to be recognized by generic receivers and may lead to such descriptors or private data being ignored.

In light of the above, any network specification should not redefine or extend descriptors defined in this standard. When any additional descriptors are used, it is highly recommended to co-ordinate its definition and tag allocation with EICTA so as to avoid clashes and to open the possibility for more generic standardization in the context of this standard. EICTA remains willing to co-ordinate private tag assignment and cross-operator private descriptor semantics of any new descriptor.

9.1.3 General broadcaster requirements

9.1.3.1 PSI information

PSI information is critical to the correct decoding of transport streams. Therefore broadcasters shall follow the rules on how to use PSI information strictly in accordance with this standard.

9.1.3.2 SI information

SI information is intended to be presented to the user (for example service name and event description), or assist in automating the user interface (for example language information and network information). This standard defines rules on how receivers shall present information to the user while leaving a substantial degree of freedom for individual manufacturers to define their implementation.

Broadcasters should provide meaningful SI information so that the user interface of a receiver can function properly in the eyes of the end user. In particular, this means that all descriptors used should contain meaningful data. In case of any automated function in the receiver described in this standard, the receiver shall rely on SI information being in accordance with this standard. This implies that specific SI information should be consistent and correct so as not to confuse the receiver or the end user. Applicable rules to this extent have been indicated as broadcaster requirements.

9.1.3.3 DVB compliance

Services outside the scope of this standard should be signalled in accordance with the appropriate DVB specifications. For example, data broadcasts may be identified by the inclusion of the data broadcast descriptor in the SDT.

NOTE Receivers are not required to provide access to these more advanced services. However, if broadcasters observe the appropriate DVB specifications, these services should not disturb older or lower specification receivers and can be available to newer or higher specification receivers at the manufacturer's discretion.

9.1.3.4 Quasi static elements

The definition “quasi static” is applied to certain elements of the broadcast. The expectation is that these elements only change infrequently (such as annual rather than daily events) and are suitable to be stored in non-volatile RAM. An example is when new services are introduced.

NOTE Changes to parameters identified as “quasi static” may require user attention. For example, the user may be invited to review their favourite service ordering when a new service is introduced. If this happens very frequently, it will not be helpful to the user.

9.1.4 Notation

The tables in the following sections use the notation described in Table 16.

Table 16 – Key to symbols

| Meaning | Standard applies to | |
|--|---------------------|----------|
| | Broadcast | Receiver |
| Mandatory to broadcast – this shall be present in all broadcasts | M | |
| Mandatory to interpret – receivers are required to understand and act on this item | | m |
| Conditional to broadcast – this shall be present if certain criteria are met (for example, certain signalling is required for CA controlled services) | C | |
| Recommended to broadcast – inclusion of this item improves the usefulness of broadcasts to receivers and allows them to provide better facilities to users. It is preferable for broadcasts to include this. However, receivers shall be able to work correctly without this information | R | |
| Optional to broadcast – this item is allowed in broadcasts and has a defined meaning. However, receivers shall be able to work correctly without it | O | |
| Undefined to broadcast – this item is allowed in broadcasts but has no defined use within this standard. Receivers should ignore this information unless they are designed with information from other specifications that define its use | U | |
| Forbidden to broadcast – this item is not allowed in broadcasts as it may cause confusion to receivers that conform to this standard | F | |

9.2 SI and PSI specification

9.2.1 Summary

9.2.1.1 Minimum broadcast profile

Table 17 summarises the requirements for inclusion of commonly defined tables in the PSI and SI of every broadcast stream of the same network. The subsequent subclauses provide more detail.

Table 17 – Summary of required tables

| Table | Actual | Other |
|---|--------|------------------|
| Program association table | M m | N/A |
| Program map table | M m | N/A |
| Conditional access table | C | N/A |
| Network information table (see 9.2.1.1.2) | M m | O |
| Bouquet association table | U | U |
| Service description table | M m | R m ^a |
| Event information table present/following (see 9.2.1.1.1) | M m | R m |
| Event information table schedule | O | O |
| Time and date table | M m | N/A |
| Time offset table | R m | N/A |
| Running status table | U | N/A |
| Update notification table (see 14.2) | O | N/A |

^a SDT_{other} is mandatory for advanced receivers only.

9.2.1.1.1 EIT

Provision of EIT information is mandatory for all services where the EIT_present_following_flag is set to "1".

9.2.1.1.2 NIT_{other}

In certain environments transmission of NIT_{other} may be more valuable than others. For example, where MFN cells overlap with a SFN_{other} transmission, the NIT_{other} may be useful, as it provides cross carriage between networks that are likely to be available at the same place.

9.2.1.1.3 SDT_{other}

Carriage of SDT_{other} is recommended in networks in order to allow receivers to detect any changes in the multiplexes and services carried on the network, and in case service_replacement linking is used to redirect receivers temporarily to replacement services (see 9.3.2.6.1).

9.2.1.1.4 EIT_{other}

Carriage of EIT_{other} is highly recommended in networks in order to improve the performance of EIT_{present/following} browser applications.

In the context of an EIT_{present/following} browser application, the receiver shall use EIT_{other} information when available (specifically, it shall be able to present the EIT_{present/following} information of all services in the current network if EIT_{other} is available). The receiver is not required to tune to another multiplex in order to acquire EIT_{present/following} information from other multiplexes in the same network in case no EIT_{other} table is present.

In order to be able to handle networks without EIT cross carriage or reception situations involving multiple networks, it is recommended practice for receivers to be able to provide scanning and caching functions to be able to present comprehensive EIT_{present/following} information in the context of an EIT_{present/following} browser application if this is appropriate for such an application.

9.2.2 Program association table

9.2.2.1 Minimum broadcast profile

This table shall be included in all transport streams to meet the requirements of ISO/IEC 13818-1 and TS 101 154.

9.2.2.2 Minimum receiver functionality

Receivers shall respond to this table to meet the requirements of ISO/IEC 13818-1 and TS 101 154.

9.2.2.2.1 Dynamic signalling

The PAT as described in ISO/IEC 13818-1 is a dynamic table. As such, it may change frequently. The receiver shall correctly reflect these changes.

It may not always be possible for receivers to respond seamlessly to such changes. However, the duration and magnitude of any disturbance should be no worse than that experienced when the user changes service.

9.2.3 Program map table

9.2.3.1 Minimum broadcast profile

Each service in each transport stream shall include a PMT to meet the requirements of ISO/IEC 13818-1 and TS 101 154. The table shall carry descriptors (as listed in Table 18 and Table 19 below) to meet the requirements of ISO/IEC 13818-1, TS 101 154, EN 300 468 and TR 101 211.

Table 18 – Program descriptors

| Descriptor | Tag | Status |
|-----------------------------------|------|--------|
| Conditional access descriptor | 0x09 | C |
| Private data specifier descriptor | 0x5F | C |

Table 19 – Elementary stream descriptors

| Component | Descriptor | Tag | Status |
|----------------------|-----------------------------------|------|--------|
| Any | Stream identifier descriptor | 0x52 | C m |
| | Conditional access descriptor | 0x09 | C |
| | Private data specifier descriptor | 0x5F | O |
| Audio | ISO 639 language descriptor | 0x0A | C m |
| Private data (AC-3) | AC-3 descriptor | 0x6A | C |
| Private data (EAC-3) | Enhanced_AC-3 descriptor | 0x7A | C |
| DVB subtitles | Subtitling descriptor | 0x59 | C m |
| Teletext | Teletext descriptor | 0x56 | C m |
| SSU stream | Data broadcast id descriptor | 0x66 | O |

9.2.3.1.1 Stream identifier descriptor

Stream identifier descriptors shall be added in at least the minimum cases specified by TR 101 211.

9.2.3.1.2 Conditional access descriptor

The conditional access descriptor shall be included in at least the cases specified by ISO/IEC 13818-1.

9.2.3.1.3 ISO 639 language descriptor

This descriptor shall be provided for each audio component if more than one audio component is present. It is recommended in case of a single audio stream. See TS 101 154.

As defined by ISO/IEC 13818-1, this descriptor identifies the language of the audio stream and also the purpose of the stream via the `audio_type` field. The `audio_type` 'undefined' (0x00) shall be used to designate normal program audio.

For an audio stream coded as dual-mono (i.e. MPEG dual-channel, or AC-3 1+1 mode), the descriptor shall contain two language codes describing the two audio channels contained in the dual-mono stream. The sequence of codes identifies the language for each audio channel as follows: the first code signals the language of the left channel, channel 1, of the dual-mono stream, and the second code signals the language of the right channel, channel 2.

The ISO 639 language code 'qaa' may be used to signal audio components that carry the original program language (e.g. the original language of a movie) in line with EN 300 468, Annex F, however the explicit language code shall be used when possible.

When an audio stream is tagged with the ISO 639 language code 'qaa', the receiver may represent this as 'original language' to the user.

NOTE Broadcasters should recognise that receivers may not select the audio stream with language code "qaa" automatically and an alternative audio stream with an explicit language code (e.g. "fre") that will be recognised by the majority of users should also be provided.

9.2.3.1.4 AC-3 descriptor

If an AC-3 audio component is broadcast, then this descriptor shall be provided (see 7.3.3). It is optional to broadcast an AC-3 audio component. Its use is as defined in EN 300 468 and TS 101 154.

9.2.3.1.5 Enhanced_AC-3 descriptor

If an Enhanced AC-3 audio component is broadcast, then this descriptor shall be provided (see 7.3.3). It is optional to broadcast an Enhanced AC-3 audio component. Its use is as defined in EN 300 468 and TS 101 154.

9.2.3.1.6 Subtitling descriptor

This descriptor shall be provided for any DVB subtitle components (see Clause 10). Its use is as defined in EN 300 468.

9.2.3.1.7 Teletext descriptor/VBI data descriptor

One of these descriptors shall be provided for any teletext/VBI data component (see Clause 11). Its use is as defined in EN 300 468, TR 101 211.

9.2.3.1.8 Data broadcast id descriptor

This descriptor is used to indicate the location of a DVB software download stream or a DVB SSU UNT (table). The type indication of the download is contained in the descriptor as per TS 102 006.

9.2.3.1.9 Download signalling

Download signalling specific to the network, such as a data broadcast ID descriptor, may be included in the PMT. This standard does not address this signalling. However, broadcasters are required to ensure that it is not easily confused with other signalling. Receivers should not respond to such signalling unless it is intended for them. See Clause 14.

9.2.3.2 Minimum receiver functionality

In addition to the summary below, see also 9.3.2.

9.2.3.2.1 Video

If a video component is present, receivers shall start presenting it on selection of the service. If there is more than one video component present, the receiver shall provide the user with a method to select between the streams.

By default, advanced receivers shall present an AVC video stream (as identified by the associated stream type in the PMT) where there is a choice between MPEG2 and AVC video streams.

9.2.3.2.2 Audio

If an audio component is present, receivers shall start presenting it on selection of the service.

If there is more than one audio component present, the receiver shall attempt to present the stream(s) that best meet the user's preferences. See 9.3.2.2.

9.2.3.2.3 DVB subtitles

See 9.3.2.3.

9.2.3.2.4 Teletext

See 9.3.2.4.

9.2.3.2.5 Multiple components of the same type

The PMT may contain multiple instances of components with identical signalling. For example, multiple audio components with the same stream type, language and audio_type.

The receiver behaviour in this circumstance is implementation dependant.

9.2.3.2.6 Dynamic signalling

The PMT as described in ISO/IEC 13818-1 is a dynamic table. As such it may change frequently. The receiver shall correctly reflect these changes.

It may not always be possible for receivers to respond seamlessly to such changes. However, the duration and magnitude of any disturbance should be no worse than that experienced when the user changes service.

9.2.4 Conditional access table

9.2.4.1 Minimum broadcast profile

This table shall be included when one or more components of the transport stream are CA controlled, to meet the requirements of ISO/IEC 13818-1.

9.2.4.2 Minimum receiver functionality

This data is CA system specific and therefore outside the scope of this standard.

9.2.5 Network information table

9.2.5.1 Minimum broadcast profile

This table shall be included to meet the requirements of ISO/IEC 13818-1, EN 300 468 and TR 101 211. In particular, description of all transport streams in the ‘actual’ network is mandatory. There shall be exactly one NIT_{actual} in each transport stream.

The NIT shall carry descriptors (as listed in Tables 17 and 18) to meet the requirements of EN 300 468 and TR 101 211.

9.2.5.1.1 Quasi static information

All of the information in the NIT is quasi static (see 9.1.3.4). Changes in this information are typically associated with evolution of the network, for example, the introduction of new relay transmitters or new services.

The service_list_descriptor in the NIT carries information about services in other transport streams. Changes in the set of services in the network are reflected in this service list. Such changes are expected to be infrequent.

9.2.5.1.2 Network descriptors (first loop)

The first loop in the NIT may carry the descriptors listed in Table 20.

Table 20 – Network descriptors (first loop)

| Descriptor | Tag | Status | |
|--------------------------------------|------|--------|-------|
| | | Actual | Other |
| Network name descriptor | 0x40 | M m | M m |
| Multilingual network name descriptor | 0x5B | O m | O m |
| Linkage descriptor | 0x4A | C | C |
| Private data specifier descriptor | 0x5F | C | C |
| Eacem stream identifier descriptor | 0x86 | R | O |

9.2.5.1.2.1 Linkage descriptors

Where the network provides a multiplex that carries EIT schedule information for all of the services in the network (a “barker” service), then broadcasts shall include a single linkage descriptor of type 4 (“TS containing complete Network/Bouquet SI”) to identify the location of this additional SI. Linkage descriptors of type 4 shall not be included unless at least this SI information is provided on the referenced multiplex.

Linkage descriptors of type 0x09 (SSU service) and 0x0A (SSU scan) can be carried in the NIT to provide network wide linking to the SSU service location. Use of type 0x0A (SSU scan) is not recommended in terrestrial networks since NITs should typically not be large and are under control of a single organization.

Linkage descriptors with other type values are undefined in this location.

9.2.5.1.2.2 Eacem stream identifier descriptor

This descriptor provides a high level signal indicating that all of the service information for a network complies with this standard. Transmission of this descriptor is recommended (when conforming to this standard) because the receiver can “behave in a more reliable way” when this descriptor is seen in incoming streams.

NOTE For example, when presenting extended event information, receivers can rely on the semantic defined under 9.2.8 that extended information complements the information in the short event descriptor.

9.2.5.1.2.3 Download signalling

Download signalling specific to the network, such as a linkage descriptor, may be included in the NIT. This standard does not address this signalling. However, broadcasters are required to ensure that it is not easily confused with other signalling. Receivers should not respond to such signalling unless it is intended for them. See Clause 14.

9.2.5.1.3 Transport stream descriptors (second loop)

The second loop of the NIT may carry the descriptors listed in Table 21.

Table 21 – Transport stream descriptors (second loop)

| Descriptor | See also | Tag | Status | |
|---|------------|------|------------------|------------------|
| | | | Actual | Other |
| Terrestrial delivery system descriptor | | 0x5A | M | M |
| Frequency list descriptor | | 0x62 | R | R |
| Service list descriptor | | 0x41 | R | R |
| Private data specifier descriptor | 9.2.11.1 | 0x5F | C | C |
| Logical channel descriptor | 9.2.11.2.2 | 0x83 | O | O |
| HD simulcast descriptor | 9.2.11.2.5 | 0x88 | O m ^a | O m ^a |
| ^a It is mandatory for advanced receivers to interpret this descriptor if they also interpret the logical channel descriptor. | | | | |

9.2.5.1.3.1 Cross-carriage of SI

The NIT_{actual} lists all of the transport streams and services in the actual network (i.e. the network of which this transport stream is a part).

There is no requirement to cross-carry information about other networks. However, if such information is carried, it shall be complete.

9.2.5.1.3.2 Terrestrial delivery system descriptor

Receivers should use the modulation parameters (see below) in the `terrestrial_delivery_system_descriptor` as a recommendation when trying to tune to a multiplex. The receiver should however always be able to detect the modulation from the transmission itself (e.g. assisted by TPS bits).

Operators can broadcast the same transport stream in the same network using different modulation parameter settings. This allows for optimization of the network coverage in frequency planning involving SFN and MFN combination networks.

The modulation parameters carried in the `terrestrial_delivery_system_descriptor` are recommended to be those applicable to the majority of receivers in that network. The

modulation parameters in the `terrestrial_delivery_system_descriptor` shall be consistent with the multiplex carried on the frequency indicated in that descriptor.

The `terrestrial_delivery_system_descriptor` fields defining "modulation parameters" above are:

- `constellation` ;
- `code_rate_HP` ;
- `code_rate_LP` (if applicable);
- `guard_interval`;
- `transmission_mode`.

9.2.5.1.3.3 Frequency list descriptor

This descriptor should be included for terrestrial delivery systems where the same transport stream is transmitted on more than one frequency.

Where included, it shall provide a complete list of alternative frequencies and shall be structured as recommended by TR 101 211.

9.2.5.1.3.4 Service list descriptor

Broadcasting of the `service_list_descriptor` is recommended in networks to enhance a receiver's capability to detect changes in the network.

9.2.5.1.3.5 Logical channel descriptor

This descriptor may optionally be included in broadcasts to provide a default channel number label for services. See 9.2.11.2.2.

9.2.5.1.3.6 HD simulcast descriptor

This descriptor may optionally be included in broadcasts when SD and HD services are being simulcast. See 9.2.11.2.5.

9.2.5.2 Minimum receiver functionality

See 9.4.

9.2.5.2.1 Linkage descriptor

Receivers are not required to take advantage of linkage descriptors in the NIT.

9.2.6 Bouquet association table

No additional semantics are defined based on this table.

NOTE There is no requirement for receivers to provide features based on this table.

9.2.7 Service description table

9.2.7.1 Minimum broadcast profile

This table shall be included to meet the requirements of EN 300 468 and TR 101 211. The SDT shall carry descriptors to meet the requirements of EN 300 468 and TR 101 211.

9.2.7.1.1 Quasi static information

Much of the information in the SDT is quasi static (see 9.1.3). Changes in this information are typically associated with evolution of the network, for example, the introduction of new services.

The following descriptors shall be quasi-static (when present):

- service_descriptor;
- multilingual_service_name_descriptor;
- preferred_name_list_descriptor;
- CA identifier descriptor.

The running status of the service is not quasi static and may change frequently. Also, any linkage descriptors of type 5 (service replacement service) are not quasi static.

Table 22 – Service descriptors

| Descriptor | See also | Tag | Status | |
|-----------------------------------|------------|------|------------------|------------------|
| | | | Actual | Other |
| CA identifier descriptor | | 0x53 | C | C |
| Service descriptor | 9.5.1.1 | 0x48 | M m | M m |
| Multilingual service descriptor | 9.5.1.1 | 0x5D | O m | O m |
| NVOD reference descriptor | | 0x4B | F | F |
| Time shifted service descriptor | | 0x4C | F | F |
| Private data specifier descriptor | 9.2.11.1 | 0x5F | C | C |
| Mosaic descriptor | | 0x51 | O | O |
| Linkage descriptor | | 0x4A | O m ^a | O m ^a |
| Preferred name list descriptor | 9.2.11.2.3 | 0x84 | O | O |

^a Linkages type 5 are mandatory for advanced receivers only.

The requirements below are in addition to those listed in EN 300 468 and TR 101 211.

9.2.7.1.2 Cross-carriage of SI

The SDT_{actual} and SDT_{other} shall list all of the services for all of the transport streams of the actual network.

The description of a service in the SDT_{other} of other transport streams shall be identical to the description of that service in the SDT_{actual} in the transport stream that carries it.

9.2.7.1.3 CA identifier descriptor

The CA identifier descriptor shall be included if scrambling is generally applied to the service.

If the service is associated with a CA-system in the SDT using this descriptor the receiver may decide not to present the service to the user in case it has no access to the CA-system in question. Operators are recommended not to include the CA_identifier_descriptor in case the service needs to be represented in the service list of every receiver.

NOTE Service providers should be aware that some receivers may have a user option to conceal CA controlled services that are not compatible with the CA systems available to the receiver. So, services that are only infrequently scrambled should not be identified with a CA identifier descriptor.

9.2.7.1.4 Linkage descriptor

Where the network provides one or more services which are not always in the “running”⁷ state, broadcasters can optionally include a linkage descriptor of type 5 (service replacement service) for those services, to identify a service that can be presented if a receiver selects this service at a time when it is labelled as “not running”.

Linkage descriptors with other type values when carried in the SDT are undefined in this standard.

Broadcasters should be aware of some of the consequences from the prescribed receiver behaviour for this service replacement linkage descriptor (see 9.3.2.6.1) when using this descriptor:

The receiver will not follow the linkage descriptor:

- if the replacement service is in a multiplex not receivable at the receiver’s location;
- when the replacement service is “not running” (irrespective of a potential service linkage descriptor accompanying this replacement service).

When the original service becomes “running” again, the receiver will switch back immediately to this original service. Broadcasters are advised to broadcast audio-visual signals on the original and replacement services in such a manner that this switchback is perceived logically by and is comprehensible to the viewer.

In case the original service and the replacement service are in different multiplexes, and when the SDT_{other} containing the information of the original service is not cross-carried into the multiplex of the replacement service, this automatic switch-back will not occur, as the receiver cannot monitor the status of the original service.

Broadcasters are urged to prevent cyclic loops of non-running services with linkage descriptors of type 5 pointing to other non-running services.

Broadcasters who wish to simulcast HD and SD services on an event basis can use this descriptor in the SDT entry for the HD service to point at the SD service. This will allow a receiver to correctly switch from the HD service to the SD service when the HD service changes to the “not running” state, and to change back again when it is “running” again.

9.2.7.1.5 NVoD services

NVoD reference descriptor and time shifted service descriptor are not supported in this standard. Each component of an NVoD service can however be described as a normal service.

NOTE The reasons for this deprecation are:

- that the NVoD use of DVB SI is not backwards compatible with traditional SI;
- it requires further technical precision to ensure interoperability;
- NVoD is generally uneconomic in the bandwidth constrained terrestrial environment.

9.2.7.1.6 Download signalling

Download signalling specific to the network, such as a data broadcast descriptor, may be included in the SDT. This standard does not address this signalling. However, broadcasters are required to ensure that it is not easily confused with other signalling. Receivers should not respond to such signalling unless it is intended for them.

⁷ The term “running” in this context means user recognisable service content, as distinct from service maintenance content such as software update download.

9.2.7.2 Minimum receiver functionality

See 9.4.

9.2.7.2.1 Service types

Receivers should only list a service in their service selection interfaces where the service is of a type that the receiver is able to present to the user.

NOTE Users may be confused or frustrated if the receiver presents for selection services that are not decodable by the receiver (such as future interactive services) or are not intended for user selection (such as receiver firmware update broadcasts).

Standard receivers shall support at least the following service types:

type = 0x01, digital television service;

type = 0x02, digital radio sound service.

In addition, advanced receivers shall support at least the following service types:

type = 0x0A, advanced codec digital radio service;

type = 0x16, advanced codec SD digital television service;

type = 0x19, advanced codec HD digital television service.

Note for clarification: services with service_type = 0x01 may carry video encoded in different type of codecs, including HD and advanced codecs. This is defined in EN 300 468 and TR 101 211. The video codec used for the service may even vary over time. It is however a reasonable expectation that basic receivers will not be able to decode services with service_type = 0x0A, 0x16 or 0x19.

Support for other service types (for example type = 0x06, mosaic service) is optional.

9.2.7.2.2 Linkage descriptors

Standard receivers are not required to take advantage of linkage descriptors of type 5, however advanced receivers shall support them in this location.

9.2.8 Event information table

9.2.8.1 Minimum broadcast profile

The event information table (EIT) shall be included to meet the requirements of EN 300 468 and TR 101 211. The EIT shall carry descriptors to meet the requirements of EN 300 468 and TR 101 211.

Table 23 – Event information descriptors

| Descriptor | See also | Tag | Status | | | |
|--------------------------------------|------------|------|-------------------|-------|-----------------------|-------|
| | | | Present/following | | Schedule ^a | |
| | | | Actual | Other | Actual | Other |
| short event descriptor | 9.5.1.1 | 0x4D | M m | M m | M | M |
| extended event descriptor | | 0x4E | O | O | O | O |
| component descriptor | 9.5.1.1 | 0x50 | M | M | O | O |
| CA identifier descriptor | | 0x53 | C | C | C | C |
| content descriptor | | 0x54 | R | R | R | R |
| multi lingual component descriptor | 9.5.1.1 | 0x5E | O | O | O | O |
| parental rating descriptor | | 0x55 | Om | O | O | O |
| time shifted event descriptor | | 0x4F | F | F | F | F |
| private data specifier descriptor | 9.2.11.1 | 0x5F | C | C | C | C |
| PDC descriptor | B.2 | 0x69 | C | C | C | C |
| Preferred name identifier descriptor | 9.2.11.2.4 | 0x85 | O | O | O | O |

^a It is optional for broadcasts to include EIT schedule information. However, if EIT schedule information is present, then it shall be as specified here.

The requirements below are in addition to those listed in EN 300 468 and TR 101 211.

9.2.8.1.1 Cross-carriage of SI

All broadcasts shall carry EIT_{present} and EIT_{following} information for ALL services in the actual network.

The description of an event in the EIT_{present} and EIT_{following} of other transport streams shall be identical to the description of that event in the EIT_{present} and EIT_{following} in the transport stream that carries the event.

Cross-carriage of schedule information between transport streams is optional.

9.2.8.1.2 Present/following

For all services where EIT_present_following_flag is set to “1”, broadcasts shall provide EIT present following information on all transport streams of the same transmission network.

9.2.8.1.3 Schedule

The broadcasting of EIT schedule information is not required or fully specified by this standard. However, where EIT schedule information is provided, it shall include a short event descriptor which shall follow the rules on the use of that descriptor in the EIT present/following information.

9.2.8.1.4 Time shifted events

Time shifted events/services are not supported. Broadcasters wishing to operate an NVoD service should use the SI for stand-alone services.

9.2.8.1.5 CA identifier descriptor

The CA identifier descriptor shall be included if scrambling is applied to the event. The set of CA system IDs signalled in the EIT augments any possible values signalled in the SDT.

9.2.8.1.6 Content descriptor

This recommended descriptor is as defined in EN 300 468.

9.2.8.1.7 Parental rating

This optional to broadcast descriptor is as defined in EN 300 468. Care should be taken that local variations on semantics of this descriptor may be in use (e.g. to be compliant with applicable regulation).

Broadcasting rules for the transmission of the parental_rating_descriptor are out of the scope of this standard. It is mandatory that the DVB definition with respect to the rating values are respected, i.e. it is allowed to use subsets of the DVB values but not to alter the defined meaning. Any extensions to the DVB meaning of "rating" should use the space identified by DVB for such purposes.

9.2.8.1.8 Short event descriptor

The short event descriptor provides the basic event description which may be presented to users. The information in this descriptor should be self-contained to accommodate receivers that only show this information and not any of the possible extended event information.

9.2.8.1.9 Extended event descriptor

No semantics are specified for the item_char and item_description_char part of this descriptor.

NOTE 1 The receiver treatment of this itemised information is not defined. Some receivers may not have a method to display this information to the consumer.

The text_char part of the descriptor provides an element of a longer text string. This allows strings of up to 3 984 bytes to be transmitted.

The information in the text_char part of the descriptor should complement that in the short event descriptor.

NOTE 2 The information should make sense whether the receiver presents a display where the text_char follows the short event description or as an alternative display.

9.2.8.1.10 PDC descriptor

If the event information for a service includes the PDC descriptor then a teletext stream including PDC data conforming to ETS 300 231 shall be one of the components of the service or accurate EIT timing shall be provided.

If a teletext stream including PDC data conforming to ETS 300 231 is one of the components of the service then all provided EIT sections (present, following and schedule) shall include a PDC descriptor.

See also items d) and e) under 9.6.3.

9.2.8.2 Minimum receiver functionality

See 9.5 and 9.3.3.

9.2.9 Time and date table and time offset table

9.2.9.1 Minimum broadcast profile

Each multiplex shall carry the TDT to meet the requirements of EN 300 468 and TR 101 211. The value of time described by the TDT when it is emitted shall be within ± 2 s of UTC.

Additionally, it is mandatory that each multiplex also carries the TOT. This allows automatic installation of daylight saving time in the receiver.

Table 24 – Time offset table descriptors

| Descriptor | Tag | Status |
|------------------------------|------|--------|
| Local time offset descriptor | 0x58 | M m |

The TOT shall carry one or more local time offset descriptors. These shall provide the local time offsets at least for the countries where the service is intended to be received.

The 900 series country codes registered in ETR 162 shall not be used in the local time offset descriptor.

NOTE This exclusion is for the following reasons:

- the 900 code for Scandinavia covers more than one time zone;
- the 900 series are not suitable for direct presentation to the user.

The local time offset descriptor shall be updated to reflect the next time offset and the time of next change as soon as practical after a change in the current time offset.

9.2.9.2 Minimum receiver functionality

The receiver shall maintain a clock based on the time signalled in the TDT. This shall be used for time based functions such as the presenting event running times.

The receiver shall provide a method for the user to enter the local offset from UTC to enable correct receiver operation in areas where broadcasts do not include the TOT.

If the receiver is intended for sale into countries in different time zones, it should provide a method for configuring the country of installation so that the TOT (when available) can be used.

Where a country spans more than one time zone, the receiver shall provide a method for configuring the country and region of installation.

9.2.10 Running status table

No additional semantics are defined based on this table.

NOTE There is no requirement for receivers to provide features based on this table.

9.2.11 Private data

9.2.11.1 Private data signalling

Where any private descriptors, other than those defined in this standard, are present in a broadcast, a private data specifier descriptor (see EN 300 468) shall be present to identify the definer of the private descriptor. The semantics of the scope of the private data specifier

descriptor are as defined in TR 101 211. Also note the recommendations in 9.1.2.3 on this matter.

The private data specifier value 0x00000028 is registered in ETR 162 to designate private data defined by this standard. Table 25 lists this value and the private SI items that are defined within its scope.

Table 25 – Private SI recognised by this standard

| Organisation/ specification | PDSID | Private SI information | Value | Type |
|--------------------------------|------------|---|-------|----------------|
| EACEM | 0x00000028 | Eacem stream identifier descriptor | 0x86 | Descriptor tag |
| | | Logical channel descriptor | 0x83 | Descriptor tag |
| | | Preferred name list descriptor | 0x84 | Descriptor tag |
| | | Preferred name identifier descriptor | 0x85 | Descriptor tag |
| | | HD simulcast logical channel descriptor | 0x88 | Descriptor tag |

Broadcasts may include other private data specifier descriptors to introduce other private data.

9.2.11.2 Private descriptors

This subclause defines private descriptors recognised by this standard.

9.2.11.2.1 Eacem stream identifier descriptor

The `eacem_stream_identifier_descriptor` is a descriptor defined for use in the first loop of the NIT, it identifies a network which conforms completely with this standard.

Table 26 – Syntax of the eacem stream identifier descriptor

| Syntax | No. of bits | Type |
|--|-------------|--------|
| <code>eacem_stream_identifier_descriptor () {</code> | | |
| <code>descriptor_tag</code> | 8 | uimsbf |
| <code>descriptor_length</code> | 8 | uimsbf |
| <code>version_byte</code> | 8 | uimsbf |
| <code>}</code> | | |

9.2.11.2.1.1 descriptor_tag

This 8 bit field with a value of 0x86 identifies this descriptor.

9.2.11.2.1.2 descriptor_length

This 8 bit integer identifies the number of bytes following this length field.

9.2.11.2.1.3 version_byte

This 8 bit integer identifies the version of this standard that broadcasts conform to. Value '1' indicates this edition, higher values imply backward compatible supersets of this standard.

9.2.11.2.2 Logical channel descriptor

The logical channel descriptor provides a default channel number label for services. This information is quasi-static. The logical channel descriptor may be inserted more than once in the second descriptor loop of the NIT. The logical channel number should be unique within

the same network_id (except when its value is zero) but may be re-used for regional variants of a service normally under different network_ids. Hence, the number is not unique within the original network. The logical channel number does not take into account the service type. See 9.4.4.

Table 27 – Syntax of the logical channel descriptor

| Syntax | No. of bits | Type |
|-----------------------------|-------------|--------|
| logical_channel_descriptor{ | | |
| descriptor_tag | 8 | uimsbf |
| descriptor_length | 8 | uimsbf |
| for (i=0; i<N; i++){ | | |
| service_id | 16 | uimsbf |
| visible_service_flag | 1 | bslbf |
| reserved | 5 | bslbf |
| logical_channel_number | 10 | uimsbf |
| } | | |
| } | | |

9.2.11.2.2.1 descriptor_tag

This shall be assigned to be 0x83.

9.2.11.2.2.2 service_id

This is a 16-bit field which serves as a label to identify this service from any other service within the network. The service_id is the same as the program_number in the corresponding program_map_section. Services shall be included irrespective of their running status.

9.2.11.2.2.3 reserved

All “reserved” bits shall be set to ‘1’.

9.2.11.2.2.4 visible_service_flag

When set to ‘1’, this 1-bit field indicates that the service is normally visible and selectable (subject to the service type being suitable, etc.) via the receiver service list. When set to ‘0’ this indicates that the receiver is not expected to offer the service to the user in normal navigation modes. However, the receiver should provide a mechanism to access these services (for example, by direct entry of the logical channel number).

See also 9.4.4.2.

9.2.11.2.2.5 logical_channel_number

This is a 10-bit field which indicates the broadcaster preference for ordering services. Its use is defined in Table 28:

Table 28 – Logical channel number

| logical_channel_number | Description |
|--|---|
| 0 | Service not suitable for selection by the user ^a |
| 1 – 999 | logical_channel_number |
| 1000 – 1023 | rfu |
| ^a For example, the value zero may be used for data services only intended for selection from interactive applications or for firmware download services, etc. | |

See also 9.4.4.2.

For ease of use, it is recommended not to use logical channel numbers greater than 99 where possible.

9.2.11.2.3 Preferred name list descriptor

The preferred name list descriptor provides a list of alternative names, and name identifiers, for the service. This information is quasi-static. The preferred name list descriptor may be inserted once in the SDT for each value of service_id.

Table 29 – Syntax of the preferred name list descriptor

| Syntax | No. of bits | Type |
|---------------------------------|-------------|--------|
| preferred_name_list_descriptor{ | | |
| descriptor_tag | 8 | uimsbf |
| descriptor_length | 8 | uimsbf |
| for (i=0; i<N; i++){ | | |
| ISO_639_language_code | 24 | bslbf |
| name_count | 8 | uimsbf |
| for (j=0; j<N; j++){ | | |
| name_id | 8 | uimsbf |
| name_length | 8 | uimsbf |
| for (k=0; k<N; k++){ | | |
| char | 8 | uimsbf |
| } | | |
| } | | |
| } | | |
| } | | |

9.2.11.2.3.1 descriptor_tag

This shall be assigned to be 0x84.

9.2.11.2.3.2 ISO_639_language_code

This 24 bit field defines the language of the service name.

9.2.11.2.3.3 name_count

This 8 bit field specifies the number of alternative preferred names that are defined for this service.

If preferred names are provided in more than one language, then the same number of names shall be provided and the set of name identifiers shall be the same in all languages.

No more than 5 preferred names shall be defined for each service.

9.2.11.2.3.4 name_id

This 8 bit integer provides an identifier for the preferred name.

The service name provided by the service_descriptor and the multilingual_service_name_descriptor are assigned the identifier 0 (zero). In this way, the name_id is always greater than 0.

9.2.11.2.3.5 name_length

This 8 bit integer specifies the number of bytes in the service name.

9.2.11.2.3.6 char

This is an 8 bit integer. A string of these char specify a preferred name for the service. The text is coded as in the service_descriptor char field.

9.2.11.2.4 Preferred name identifier descriptor

The preferred name identifier descriptor may be used in the EIT. It identifies the preferred service name at the time of an event and so allows a schedule of service names. In the absence of the descriptor, the default service name is that defined by the service_descriptor and the multilingual_service_name_descriptor. These names can also be specified explicitly by setting the name identifier to 0 (zero).

Table 30 – Syntax of the preferred name identifier descriptor

| Syntax | No. of bits | Mnemonic |
|---|-------------|----------|
| preferred_name_identifier_descriptor () { | | |
| descriptor_tag | 8 | uimsbf |
| descriptor_length | 8 | uimsbf |
| name_id | 8 | uimsbf |
| } | | |

9.2.11.2.4.1 descriptor_tag

This shall be assigned to be 0x85.

9.2.11.2.4.2 name_id

This 8 bit integer identifies a preferred service name within the list of service names defined by the preferred name list descriptor.

9.2.11.2.5 HD simulcast descriptor

The HD simulcast logical channel descriptor provides a means to override the default channel number label of services for an advanced receiver. This information is quasi-static. The HD simulcast logical channel descriptor may be inserted in the second descriptor loop of the NIT. The descriptor may appear more than once in this location.

The constraints on uniqueness are the same as those for the logical channel descriptor.

Table 31 – HD simulcast logical channel descriptor

| Syntax | Number of bits | Identifier |
|---|----------------|------------|
| HD_simulcast_logical_channel_descriptor() { | | |
| descriptor_tag | 8 | uimsbf |
| descriptor_length | 8 | uimsbf |
| for(i=0;i<N;i++){ | | |
| service_id | 16 | uimsbf |
| visible_service_flag | 1 | bslbf |
| reserved | 5 | bslbf |
| logical_channel_number | 10 | uimsbf |
| } | | |
| } | | |

9.2.11.2.5.1 descriptor_tag

This shall be assigned to be 0x88.

9.2.11.2.5.2 service_id

This is a 16 bit field which identifies a service within a TS. The service_id is the same as the program_number in the corresponding program_map_section.

9.2.11.2.5.3 Visible_service_flag

This 1-bit field when set to '1' indicates that the service is normally visible and selectable (subject to the service type being suitable, etc.) via the receiver service list. When set to '0' this indicates that the receiver is not expected to offer the service to the user in normal navigation modes however the receiver should provide a mechanism to access these services (for example, by direct entry of the logical channel label).

See also 9.4.4.2.

9.2.11.2.5.4 reserved

All "reserved" bits shall be set to '1'.

9.2.11.2.5.5 logical_channel_number

This is a 10-bit field which indicates the broadcaster preference for the ordering of services.

This descriptor shall only be interpreted by receivers that are able to decode an advanced codec HD digital television service. The channel number label assignment defined by this descriptor overrides the channel number label assignment defined by the logical channel descriptor that is located in the same network_id. The rules for the set of channel number labels used by this descriptor are the same as the rules for the set of channel number labels used by the logical channel descriptor.

In the case where this descriptor assigns to a service (service A) a channel number label which is already assigned to another service (service B) (perhaps by the Logical Channel Descriptor), the receiver shall assign the original service (service B) the channel number label that had previously been assigned to the replacement service (service A). If the replacement service (service A) had not previously been assigned a channel number label, the original service (service B) shall be automatically assigned a new channel number label in the normal manner for services with no assigned channel number labels.

The entries in this descriptor shall be processed in order and any entry for the original service (service B) shall be ignored if it occurs after the entry for the replacement service (service A). The replacement service (service B) shall not be assigned a new channel number label if at the time of processing this descriptor the reception quality of this service is poor and would result in a bad viewer experience when presented with the service. This descriptor is intended to be used for HD services broadcast in simulcast with the same service in SD so that the HD service appears at the primary channel number label on HD capable receivers while the SD service appears at that label for SD-only capable receivers.

9.2.12 Overview of service-variation options

DVB technology and this standard allow for a number of options to create multiple versions of services and to (temporally) share content between different services. Typical uses are:

- regionalised versions of services;
- services that share content/events;
- services that share bandwidth/alternate in time,
- services that are suspended referring to an “anchor” service.

This subclause presents an overview of these aspects (as covered in various clauses/subclauses of this standard or referenced DVB and MPEG specifications).

9.2.12.1 LCN use for regional equivalence services

The logical channel numbering mechanism allows different (regionalized) versions of the same “mother” service in **different networks** to be designated with the same channel number. See 9.4.4 for more details.

9.2.12.2 Changing service name

Most SDT parameters are qualified as quasi-static including the service name. The preferred_name_list_descriptor carried in the SDT and the preferred_name_identifier_descriptor carried in the EIT allows re-labelling of the service name on an event basis, thus allowing dynamic “branding” of the service provider. For further reference see 9.2.11.2.3, 9.2.11.2.4 and 9.5.2.1.1.

9.2.12.3 Running status and service replacement

The running_status field of a service in the SDT is dynamic by nature. It may signal the service is: not running, starts in a few seconds, pausing and running. Specifically the state not-running can be used to clearly identify the service is not available at this time. For further elaboration how this mechanism can be used to create time-alternating services and local variations of services please refer to the “terrestrial systems” section of TR 101 211. See 9.3.2.6.1 and 9.3.2.6.2 of this standard for further details on this issue.

NOTE It is recommended not to create (time alternating) services that are available only during a fraction of the time as this will create user annoyance.

9.2.12.4 Dynamic PSI

By changing the component references in the PMT, variations of services can be created within a multiplex. For example, one service may temporarily switch to an alternate video and audio component to give local news while another version of that service continues with more general news items. Or the specific transmission of events of a secondary service may stop during off-peak hours and be “replaced” by the anchor service of the same service-provider. Since both services would each have their own SDT and EIT entries, they can (and would have to) be presented as two distinct services. In many ways, this mechanism can achieve the same effect as a service-replacement link, but is restricted to references within one multiplex. See 9.2.3.2.6 for details.

9.3 Receiver functions

This chapter describes the basic functionality of the receiver in viewing mode and while zapping between digital TV services. Basic receiver installation is addressed in 9.4.2. Reference is made to settings, such as user preferences, that are assumed to be set during the installation process.

The functionality listed is just a minimum requirement. It is up to the manufacturer to offer additional features in their particular product. The actual implementation and the user interface for the features described are beyond the scope of this standard.

Where a feature is appropriate to all forms of receiver (digital television or set top box) the term “receiver” is used. Where a feature is particular to one or other implementation, the abbreviations IDTV and STB are used.

Two different classes of receiver are referred to in this document. A standard receiver (digital television or set top box) is only able to receive ISO/IEC 13818-2 SD services while an advanced receiver also implements further audio and video codecs for ISO/IEC 14496-10 SD and HD services.

9.3.1 Information typically available to the user

Below is a list of the information displays that a typical receiver may present to the user. These are described in more detail in 9.5.2.

- Information about the current event being decoded.
- Overview of available events for one or more services.
- Overview of available services.

9.3.2 Service change

When changing services, there are certain options to deal with video formats, languages and unexpected failures in service selection. The minimum requirements for receiver behaviour during service change are outlined in the following paragraphs.

9.3.2.1 Video format settings

See 6.4.

9.3.2.2 Audio language

It is assumed that the user has entered one or more language preferences during the receiver installation process. If the selected service has audio tracks in more than one language, the language is selected according to the user preferences.

If no language in the preference list matches the languages available, any one of the languages available may be selected. The receiver should select the first audio track listed in the PMT.

In the case where a service has an audio stream coded as dual-mono (i.e. MPEG dual-channel, or AC-3 1+1 mode), then, if this audio stream is selected, by default the left channel, channel 1, of the dual mono stream shall be played, unless there is a preferred language or manual override.

In addition to this automatic soundtrack selection, it shall always be possible for the user to manually select any of the available languages.

9.3.2.3 Subtitling

Receivers are recommended to allow the following user preferences to be set:

- specification of the user's preferred speech language (this can be a single preference or, optionally, an ordered list);
- specification of the user's preferred subtitling mode from: "for translation" or "for the hearing impaired".

The required behaviour for these modes is described in Table 32 below:

Table 32 – Subtitle preference modes defined

| | |
|----------------------|---|
| For translation | Present the "normal" subtitle stream (if one is available) that has the best match to the user's preferred speech language |
| For impaired hearing | Present the "for hearing impaired" subtitle stream. If no "for hearing impaired" subtitle stream is available, then present the "normal" subtitle stream (if one is available). In either case, present subtitles that have the best match to the user's preferred speech language |

In either mode, the user shall be able to toggle the presentation of subtitles "on" or "off" and shall be able to select alternative subtitle languages if they are available.

The recommended factory default is "on" "for translation".

9.3.2.4 Teletext

The receiver behaviour depends upon both the service type (teletext service or TV/Radio service) and the receiver's capabilities (local decoding or insertion into the VBI output of the receiver). See Clause 11.

Receivers with the main video output via HDMI shall decode the teletext stream locally.

9.3.2.5 CA controlled services

When any component(s) of the selected service remain scrambled (because they are not compatible with the receiver's CA system or the receiver has no CA system), the receiver shall behave in the following way:

9.3.2.5.1 TV services

The receiver shall try to present all of the components of the service in accordance with the user's preferences.

Where any components cannot be presented due to scrambling, an error message shall be presented.

9.3.2.5.2 Radio services

The receiver shall try to present all of the components of the service in accordance with the user's preferences.

Where any components cannot be presented due to scrambling, an error message shall be presented (in case the main TV display is not active when in radio mode, alternative methods of presenting error messages may be necessary).

9.3.2.5.3 Teletext services

The receiver shall try to present all of the components of the service in accordance with the user's preferences.

Where any components cannot be presented due to scrambling, an error message shall be presented.

9.3.2.6 Service not available

A service may not be available for various reasons. The required receiver behaviour is described below:

9.3.2.6.1 Service is not running, and a linkage descriptor of type 5 is present

Linkage type 5 is the "service replacement service" linkage. Broadcasters may include this descriptor for a number of reasons, for example:

- the current service is not broadcast all of the time but there is a suitable alternative service that can be used instead, for example a regional variant of a service that has a linkage descriptor pointing to its parent service;
- the current service is an HD simulcast of an SD service, in which case the linkage descriptor points at the SD service. This will ensure that users with basic receivers will not have a blank screen (or a suitable error message) when they channel change to the HD service;

NOTE 1 This situation can be avoided by making the HD service not visible in the logical channel descriptor but visible in the HD simulcast descriptor.

- the current service contains simulcast events in HD of an SD service. The running status of the current service will change to "not running" between the HD events and the linkage descriptor points at the SD version. An advanced receiver asked to display the HD service will be able to correctly switch between the HD events (on the current service) and the SD events (on the replacement service).

Receiver support for this link is optional for standard receivers but mandatory for advanced receivers. If it is supported, the receiver shall perform the following:

- switch to the service indicated in this descriptor;
- if the replacement service cannot be presented to the user, the receiver shall treat this as in the case "service not running, no link present";

NOTE 2 This situation might happen when the replacement service is in a multiplex which does not cover the receiver's location. It can also happen when the replacement service is "not running".

- while displaying the replacement service, the receiver shall monitor the status of the original service through the `running_status` in `SDTactual` or `SDTother`. When the `running_status` of the original service changes to "running", the receiver shall switch back to this original service immediately;

if the original service and the replacement service are not in the same multiplex, and no `SDTother` concerning the original multiplex is present in the multiplex of the replacement service, the receiver cannot monitor the `running_status` of the original service, and will not perform such a switch-back when the original service becomes "running" again;

NOTE 3 Hence, cross-carriage of `SDTother` is required for the switch-back after a service replacement action.

- see 9.5.3.2 for user interface consequences in perceived behaviour when zapping.

9.3.2.6.2 Service is not running, and no linkage descriptor of type 5 is present (or is not supported by the receiver)

The receiver shall present a message that the service is not available at that moment. If an `EITfollowing` section for this service is broadcast, the starting time of this next event may be used in this message to indicate when the service will probably be resumed.

9.3.2.6.3 If any part of the service cannot be rendered because of the scrambling

See 9.3.2.5.

9.3.2.6.4 If any part of the service cannot be rendered because the hardware and software resources in the receiver cannot handle this type of stream

The receiver shall be able to present at least:

- for a radio service, one audio stream;
- for a television service, one audio stream and one video stream.

If this is not possible, an error message is presented to the user indicating that some components of the service cannot be rendered.

The receiver shall present all components of the service it can present.

9.3.2.6.5 If any part of the service cannot be rendered because it is simply not available on the advertised parameters (frequency, PIDs, etc.)

An error message is presented to the user indicating that some components of the service can currently not be rendered.

The receiver shall present all components of the service it can present.

9.3.2.6.6 If the service cannot be received, because of weak or missing RF-signal

An error message should be presented to the user giving the troubleshooting techniques for lost signal (check antenna cable, etc.).

9.3.3 Parental control

The receiver shall implement a mechanism to block or effectively obscure the video of an event and optionally to block or effectively obscure the audio track of an event if the rating of the event is higher than or equal to the authorized rating entered by the owner. It is up to the receiver implementation to select an appropriate age authorization mechanism and override mechanism, for example using a pin-code.

NOTE CA systems may also be able to provide parental control through their own private methods.

Implementation note: Receivers should interpret the latest $EIT_{\text{present/following}}$ information as quickly as possible, but may temporarily display some video and reproduce some audio before the `parental_rating_descriptor` is acquired and interpreted. Since the repetition rate of the $EIT_{\text{present/following_actual}}$ is 2 s, this is the normal upper limit to such a temporary unauthorized display (typical performance can be substantially better).

9.3.4 Receiver behaviour when a service stops

It may happen that transmission of a particular service stops. This can happen for several reasons:

9.3.4.1 Service stop correctly signalled in SI

The stopping of a service may be correctly signalled by the broadcaster in two different ways:

- the service has a schedule of events and the schedule ends according to service information after a particular event and the running status is updated accordingly;
- the service does not have a schedule of events and ends without notification. However, the running status of this service is indicated correctly in the SDT.

The subsequent receiver behaviour depends on whether a linkage descriptor of type 5 is present (and supported by the receiver) or not. See 9.3.2.6.

9.3.4.2 Service stop not signalled in SI

Occasionally, the service may stop without the correct signalling. Two cases are considered:

- the service stops while the running status still indicates “running”. In this case, the receiver has to assume that this is a temporary transmission error and notifies the user accordingly. The receiver keeps on waiting until the transmission resumes or the user selects a new service;
- the service stops, because the multiplex is switched off without notification. In this case, the receiver has to assume that this is either a temporary transmission error or the antenna connection has been lost. The user is notified accordingly. The receiver keeps on waiting until the transmission resumes or the user selects a new service.

9.3.4.3 Smartcard is removed or entitlements expire or preview period expires, etc.

In these cases, the CA system is responsible for notifying the user accordingly.

If just one of the currently rendered components of the service is stopped for one of the above reasons, an appropriate message is presented while the remaining components keep on being rendered.

9.4 Establishing and maintaining the network connection

9.4.1 Use of SI identifiers

9.4.1.1 Original network ID

One `original_network_id` should be allocated per country in the case of a DVB-T network. The list of registered values is published in ETR 162 and an up-to-date list of this and other DVB Identifiers is available from <www.dvb.org>. This ETR allocates the values 0xFF00-FFFF for “Private_temporary_use”. For example, these can be used for test networks. See 9.4.2.4 for recommended receiver reaction.

Only registered values of `original_network_id` shall be used in live broadcasts.

9.4.1.1.1 Reception of multiple networks

In some situations, DTT signals can be received at the user’s premises originating from different networks belonging to the same `original_network_id` or even belonging to different `original_network_ids`. The receiver shall be able to deal with such a situation and display the available services in a single list and make no distinction in behaviour when for example navigating between services within a network and between services in different networks.

NOTE 1 In most cases, there will not be event information cross-carriage between the original networks.

NOTE 2 It is not possible on the basis of SI to automatically discriminate instances of the same service in different original networks.

9.4.1.2 Network ID

For DVB-T systems, the “network” is the infrastructure that corresponds to a single geographical region in which one or more transport streams are provided. Each transport stream is identical within the whole region. The only exception allowed is to use different regional components if the corresponding SI remains unaffected. A network might be composed of one or more transmitters (for example rebroadcast relays).

Furthermore, it is allowed to have a “stack” of networks, so that more than one network is receivable at one specific location. This is necessary in order to be prepared for network extension once the national network structure has been designed.

The information about other networks can be provided by NIT_{other}. Because of the coverage area in terrestrial systems, it is not necessary to cross-carry every NIT_{other} of the countrywide DVB-T network, only the NIT of receivable networks. In most cases, these networks are adjacent.

The process for allocating network IDs within a country is similar to the frequency planning process. This allows network ID values to be re-used provided that different networks with the same network ID are not receivable at a single location.

9.4.1.3 Service ID

Within a DVB-T network of a single country (the scope of an original_network_id), each service_id applies uniquely to one service.

Where two services have the same service_id value, they shall have the same SI and substantially the same program content, for example, differing in advertising content. Conversely, services that are identical shall typically have the same service_id while services that have differences in the events described in their service information shall have different service_id values. For example, services that differ in their regional carriage shall have different values of the service_id.

NOTE Receivers will treat services with the same original network ID/service ID in different networks as the same and will not provide a method to select between these two services. So, a danger of concealing significant differences in programme content in two services with the same service ID is that consumers in border areas will not be able to select the regional variant of their choice.

It is recommended not to re-allocate service IDs from deleted services to new services within a short period, unless the intention is that the new service replaces the old service.

9.4.1.4 Transport stream ID

The transport_stream_id shall be used to uniquely identify a transport stream within the original network. It carries a specific combination of services and components.

The same transport_stream_id may be used for transport streams transmitted on more than one network ID, provided that the differences between the transport streams with the same transport_stream_id is limited (see “service ID” above).

9.4.1.5 Local administration of identifiers

The following IDs shall be administered by the appropriate authorities (for example national regulators):

- original network ID. This shall be registered in ETR 162;
- network ID;
- transport stream ID;
- service ID;
- logical channel number.

9.4.2 Auto installation

The purpose of the auto installation is to find as many receivable services as possible.

There are two strategies for scanning for services to set up the network information in the receiver. One is to perform a full, sequential scan from the bottom to the top of a particular

frequency range and the other is using the information in the NIT to improve the performance of the scan algorithm.

The NIT delivers two kinds of information:

- the frequency that is used to transmit a certain multiplex;
- other tuning parameters for the multiplex (for example 2k/8k, guard interval, etc.).

Receivers shall provide the user with a means to run the auto installation function at any time after first installation.

9.4.2.1 Cross-carriage of NIT_{other}

In most cases, there is no cross-carriage of the NIT in other networks. In these networks, the NIT only provides information on the actual network. It follows from that that only multiplexes of the current network can be found and tuning to all remaining channels is necessary anyway. The frequency information does not therefore provide sufficient information for the setup of all networks.

The conclusion is that for auto installation a full, sequential scan is the preferred solution. Additional usage of the NIT might bring some benefit.

9.4.2.2 The scan process

The following requirements (which receivers shall fulfil) apply to the scan process:

- an initial service search will be carried out during the first installation;

This search finds all of the multiplexes and services in the relevant frequency range. The NIT is used with or without the frequency and service list for network information and the SDT to detect whether the services are running.

A service is listed in the service list only if it is found in the SDT_{actual} (as services listed in the SDT_{other}, etc. may not be available at the receiver's physical location) and it can be rendered with the receiver's resources.
- the services and certain SI data will be entered into a list and stored in non-volatile memory;
- besides the automatic full service search, the receiver should provide a manual service search, where the tuning parameter (frequency or channel number) of a multiplex can be entered manually. The receiver tunes to this frequency only and updates the service list;
- the signal quality will be measured for all multiplex channels. If the same service is found on more than one TS, the signal quality of the particular RF-signals will be used as a selection criterion. In some cases, it may be beneficial to allow the user to make the final decision;
- it is not mandated to present running audio and video services during the scan procedure, but the user shall be informed about the progress of the scan in an appropriate manner (OSD, animation). The implementation of this is up to the manufacturer.

9.4.2.3 Conditionally accessed services

Receivers shall retain information about CA controlled services, as signalled in the SDT, that are not accessible with the CA mechanisms available to the receiver at the time of installation.

The receiver shall allow CA controlled services to become selectable by the user when suitable CA means become available to the receiver without the receiver having to run the auto installation function again.

NOTE For example, non-accessible CA controlled services might initially be greyed out or concealed (possibly as a user option) but become selectable when a suitable CI module is inserted.

9.4.2.4 Test networks

ETR 162 allocates the values 0xFF00-FFFF for “Private_temporary_use”. For example, these can be used for test networks. It is recommended for normal use to ignore the multiplexes, which are part of such a test network, and not to include their services in the service list.

9.4.3 Network evolution

During the evolution of a nationwide network, services, multiplexes, transmitters and networks may be added, removed or changed. The receiver recognises these changes, by monitoring the version numbers of PSI/SI tables.

The minimum requirements for the handling of such occurrences are described below. As a result of these processes, a receiver may detect a possible permanent change in the service configuration for which it first needs further confirmation or information.

It is recommended that the receiver first asks for user confirmation before proceeding in case it requires a substantial time (for example longer than 10 s) to obtain this additional information (for example tune to a new multiplex or new frequency or even scanning the whole band). Any (confirmed) resulting updates of the service list should be handled as described in 9.5.2.2.

9.4.3.1 Network change

This will be detected when a new NIT_{actual} or NIT_{other}, as recognised by its network_id, appears and/or an existing one disappears.

NOTE 1 For example, a new NIT_{other} may appear if a new network starts operating nearby.

If the actual network changes its ID, the receiver shall assume that the current network no longer exists and has been replaced by another.

NOTE 2 The network_id of the NIT_{actual} may change following network reconfiguration, changes in reception conditions or physical relocation of the equipment.

Additionally, the set of transport streams within an existing network may change, this is reflected in the structure of the NIT and its version number.

9.4.3.1.1 Receiver reaction

A new or changed network may provide additional services. To offer the user these services, at least a network scan is necessary.

When a network is deleted (can no longer be received or its network_id has changed) the receiver shall not delete its services automatically from the service list without user confirmation.

When a transport stream is deleted (its transport_stream_id is removed from the NIT), then any resulting service list changes can be represented in the service list automatically without user confirmation.

9.4.3.2 Transmitter change

In most cases, this will be a frequency change and will be reflected in the delivery information in the 2nd loop of the NIT:

- When a main transmitter changes, then the delivery_system_descriptor is changed accordingly.
- When repeaters are added, removed or their frequency is changed, the changes are reflected in the frequency_list_descriptor.

9.4.3.2.1 Receiver reaction

The receiver shall update the service list with the new reception information. This requires testing of the frequencies to see if they provide better signal quality, or to find the next better alternative frequency, if the previously selected one is no longer available.

The manufacturer can implement a default handling routine for this purpose, for instance at power on/off.

If a transport stream disappears, the rules for network changes (see 9.4.3.1) shall be applied.

9.4.3.3 Multiplex change

These changes are reflected in the structure of the NIT (as it has a loop-over transport stream ID) and the instances of the SDT_{actual} and SDT_{other}. There will also be changes in the set of services listed where appropriate.

There may also be a change in the ID of the transport stream. This may happen because the set of services or the regionality of services within a transport stream has changed.

9.4.3.3.1 Receiver reaction

The receiver shall tune to the changed multiplex and verify the SI_{other} with SI_{actual} and PSI before updating the service list.

Where there is a new transport stream, a partial scan can be used, which scans only the necessary frequencies. The manufacturer can implement a default handling routine for this purpose, for instance at power on/off.

Note that the effect of any consequent changes in the service configuration of the network are described under service change (see 9.4.3.4).

9.4.3.4 Service change

Two service change cases that the receiver shall discriminate are considered: permanent and temporary changes.

9.4.3.4.1 Temporary change: service present, but “not running”

A temporary change is reflected in SDT running_status flags and also in the PSI. There may be temporary a “null service” which is signalled in the SDT as “not running” and is not in listed in the PSI.

The presence of such a service is not considered a service change as relevant for the context of this section, for example there is no need for a receiver to start looking for an alternative location, and no potential need to update the service list.

The subsequent receiver behaviour depends on whether a linkage descriptor of type 5 is present (and supported by the receiver) or not. See 9.3.2.6.

9.4.3.4.2 Permanent changes

Permanent changes shall be signalled through both the SDT_{actual} and SDT_{other} and the NIT service_list_descriptor. This affects the whole entry in the second loop of the SDT and the service list in the NIT.

Three kinds of changes can be distinguished:

- addition of a new service;

- moving the service between transport streams (or even between networks);
- permanent deletion of a service.

9.4.3.4.3 Cross-carriage of information when moving a service

Note for network operators: receivers complying with this standard may check all NIT_{actual} and NIT_{other} broadcasts on the network when trying to locate a “moved” service, by checking for <original_network_id> and <service_id> of such a presumably moved service. In case the service is moved to another network (which could happen when moving a service from a network with national coverage to one or more of regional networks or vice versa), the NIT_{other} will be consulted to check for the new location of the missing service. If such a new location cannot be found, the receiver might remove the service from the service list.

It is therefore recommended that network operators cross-carry NIT_{other} information accordingly when such a move between networks is to be handled automatically by receivers with the highest degree of success.

9.4.3.4.3.1 Receiver reaction

There is an order of trust between the different service information levels. SI_{other} should be seen as rough information and shall always be double checked with the corresponding SI_{actual}.

9.4.3.4.4 Addition of a new service

If a service has been added to the NIT_{actual} (or NIT_{other}) and it has been checked that it can be properly received in the SDT_{actual}, it shall be added to the service list according to 9.5.2.2.

9.4.3.4.5 Move of a service

If a service is removed from the SDT_{actual}, the receiver shall infer that the service has been deleted from the multiplex. It is recommended that the receiver then uses the information available in NIT_{actual} and NIT_{other} to decide whether the service has been deleted from the network(s), moved inside the network or moved to another network, by looking for the <original_network_id> and <service_id> of the service in these tables.

As it cannot be guaranteed that NIT_{other} is always fully cross-carried, the receiver may scan all receivable networks in the original network (either NIT_{actual} or NIT_{other}) if necessary. This may happen automatically upon service selection and should also be part of the receiver's installation functions.

If the receiver detects such a “moved” service elsewhere in the network or in another network, and after checking the SDT_{actual} (at the new location), it may replace the service's reception details in its internal database without consulting the user. No change to the service list visible to the user is needed in this case, since in the user's view, the service remains accessible as it was.

If the service cannot be found in the receivable transport streams, the receiver shall consider the service to be deleted (see 9.4.3.4.6).

9.4.3.4.6 Permanent deletion of a service

If a service is removed from the NIT_{actual} and SDT_{actual}, the receiver shall infer that the service has been deleted from the network. If the service cannot be found elsewhere in a receivable network, it shall consider the service as no longer available, and represent this as such in its service list (see 9.5.2.2).

9.4.4 Logical channel numbers (LCN)

The LCN serves at the same time two different but related purposes:

- enabling user presentation of service numbers in a convenient and familiar form;
- allowing receivers to identify regional variants of the same core service.

9.4.4.1 Broadcaster rules

Different broadcasters operating within one country can elect to choose a service numbering scheme amongst each other, probably in conjunction with appropriate coordinating authorities. This standard defines the logical channel number concept for conveying such service numbering information to receivers. Broadcasters should obey the following rules in order for receivers to be able to properly operate.

A second property of the LCN is that it provides a reference that associates regional variants of a service.

Logical channel numbers allocated should be useable directly as service numbers in a set. Therefore, large gaps in assigning service numbers or the use of 3 digit numbers should be avoided.

Services with the same original_network_id/service_id shall have the same logical_channel_number. Within the scope of one network, logical channel numbers shall be allocated uniquely. When defining regional variants of a service, the same logical_channel_number can be used (for example in neighbouring networks). This facilitates defining a consistent and compact national/regional/local channel numbering scheme, as well as indicating to the receiver that services with the same logical_channel_number are similar (regional variants).

9.4.4.1.1 Services becoming more regional

When a service becomes more regional, the existing service will be replaced by the regional service. Consequently, the service_id will be changed, the transport_stream_id may change, and the network_id will be the same. If the logical_channel_number stays the same, it indicates that the new service is a successor to the previous.

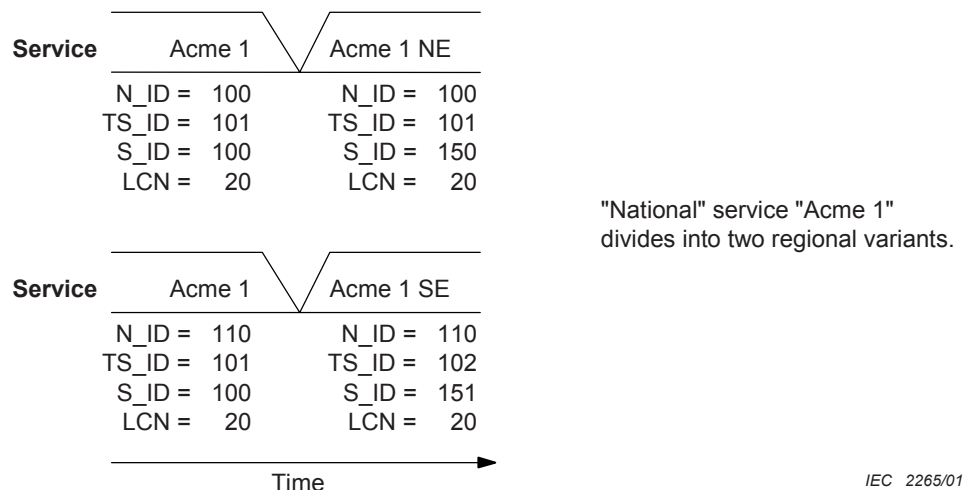

Figure 9 – Service regionalisation

9.4.4.1.2 Invisible services

It is recommended to allocate high service numbers to services marked as invisible to avoid accidental collision of service numbers with those of visible services when they are being automatically or manually reallocated.

9.4.4.1.3 SD/HD simulcast services

Where a service is being simulcast in SD and HD, it is recommended that the logical channel descriptor is used to allocate the primary logical channel number to the SD service. The HD service may be included in the descriptor at a secondary logical channel number and may have the visible flag set to '0'. The HD simulcast descriptor is then used to allocate the primary logical channel number to the HD service with the SD service moved to the secondary logical channel number.

9.4.4.2 Receiver rules

It is a manufacturer option to provide an automatic service numbering facility on the basis of logical channel numbers. However, when the manufacturer supports logical channel numbers for automatic service numbering, he shall comply to the rules set out below.

NOTE Receivers are recommended to support logical channel numbering, as they aid communication between the broadcaster and the consumer. For example, they provide a concise method for one service to describe viewing options on another service. In addition, they provide a convenient method for providing references from other media – such as printed event listings.

9.4.4.2.1 Logical channel number zero

Services associated to logical channel number 0 should be disregarded as part of the process below (irrespective of the value of the visible_service_flag). These services are not intended to be presented as part of the viewer's service list. These services are not intended to be selectable by viewers.

9.4.4.2.2 Invisible services

Services signalled as "invisible" shall be handled in the following manner:

- Receivers shall support a "default" mode in which they will not show services marked "invisible" in their user service list or selectable in normal P+/P- browsing. The receiver may ignore the presence of "invisible" services when (re-)allocating services to service numbers requested by "invisible" services.
- Receivers shall support a mode (for example as a service mode or as an installation option) in which it will allow direct selection of all services (irrespective of being marked invisible) by the user. It may display all services also as part of the user service list in this mode.
- It is a manufacturer's option to combine the two modes mentioned above, by allowing direct selection of "invisible" services while not showing them as part of the service list.

9.4.4.2.3 First initialisation

When a receiver service list is first initialised, the receiver shall perform in accordance with the following rules.

- a) It shall attempt to allocate the services to a service number equal to the logical_channel_number for that service, taking into account any re-assignment of logical_channel_number indicated in the HD simulcast descriptor. This rule implies that if there is only one service with a particular logical_channel_number available, it shall (initially) be allocated to this service number.
- b) It shall resolve any conflict between services that use the same logical channel number.
 - National preference: it is recommended to give preference to services of one original_network_id when allocating service numbers in case of a conflict (effectively implementing a country preference).
 - Regional preference: since networks shall broadcast non-conflicting logical channel numbers, the receiver may choose to give preference of one network over the other (effectively implementing a certain regional preference) in assigning services to service numbers. It may also assume that services with the same

logical_channel_number are regional variants as long as they have the same original_network_id.

- c) It is recommended to keep services from the same network that cannot be assigned to their logical_channel_number grouped together in the service list. It is recommended to preserve any ordering information among such services. In particular, in countries that plan appropriate gaps in the logical channel numbering, it is appropriate to allocate regional variants of services to the next “gap” in the service list.

If some services do not have an associated logical_channel_number, they shall get the lowest priority in the assignment of a service number. The only exception is an original_network_id preference, which allows a receiver to first allocate service numbers to all services of an original_network_id before allocating service numbers of any other original_network_id.

9.4.4.2.4 Adding a new service

If a receiver decides to add a new service to the service list, it shall first try to allocate a service number according to the successor service rules (see 9.4.4.2.6) and secondly, according to its logical channel number. In case of a conflict, it should try to allocate a free service number.

9.4.4.2.5 Removing a service

If the receiver decides a service can be removed from the service list, it will visibly delete the service and its service number from the service list. It shall preserve the information about the removed service in case a successor service is found later (see below) to allow such a successor service to take the place of the removed service in the service list. This retention mechanism also improves the robustness of the receiver against network SI errors (wrongfully signalled deletion of a service) or otherwise unintentionally removed services.

It should be noted that the (temporary) inability to receive a service as such should not be the sole reason for a receiver to delete a service from the service list: in general, additional user intervention is recommended in such a case. However, deletion of a service from the NIT_{actual} and SDT_{actual} shall be considered positive confirmation of the deletion of a service by a receiver.

9.4.4.2.6 Network re-configuration

When the receiver detects a service offer change including the addition and deletion of multiple services and/or networks, it shall first remove all services which it can (positively) determine to be permanently removed from the service list and then add the new services. Where possible, the receiver shall attempt to find suitable successor services for those services (previously) removed from the service list applying the following successor service rules:

- a) the receiver shall first try match to a new service (successor service) to a logical_channel_number and network_id and original_network_id from a service previously removed from the service list;
- b) any remaining new services shall be allowed to replace services of other networks no longer available (match only on logical_channel_number and original_network_id), taking into account rule b) under 9.4.4.2.3 (use national and regional preference) to select the most suitable candidate.

Any new services that remain after successor service rules have been applied shall be assigned in accordance with the service number allocation rules as mentioned under 9.4.4.2.3, but shall not change already existing service number allocation. Such services may take any free position in the service list, thereby potentially using the service number of a removed service that might be replaced later and thus blocking such a future successor. Receiver manufacturers should attempt to minimise such events.

It is suggested to mark (for example using an alternate colour or an icon) those services with changed status (added, deleted, or changed) in order to indicate the changes to the user.

9.4.4.2.7 Change of LCN numbering scheme

Any re-arrangement by the broadcaster of LCN numbering of services will be treated as above under network re-configuration. This implies that user changes and non-default allocation of services to service numbers by the receiver will be preserved as much as possible unless a reinstallation is done.

9.4.4.2.8 SD/HD simulcast services

A receiver capable of only decoding SD services shall only implement the logical channel descriptor, however a receiver capable of decoding HD services shall also implement the HD simulcast descriptor.

All of the above rules apply in both cases.

9.4.5 Recommendation for robust SI acquisition

9.4.5.1 Philosophy

DTT systems are typically complicated DVB systems. This complication derives from

- distributed coding and multiplexing sites using systems from multiple suppliers;
- regional variations of services and grouping of services;
- receiver installation determining the number of multiplexes that may be received (sub-set or super-set of a single network), with variation over time;
- number of remultiplexing stages;
- separate paths taken by PSI and SI information;
- distribution of SI insertion equipment.

Due to this complexity there is a risk of there being an increased number of possible failure modes, and consequent reduced MTBF, compared with a satellite or cable installation. Therefore, it is important that the receiver is as rugged as possible to failures in SI so that, as far as possible, failures in SI do not by themselves result in the inability of the receiver to receive television, data or other service components.

Wherever possible, the receiver shall use SI for information purposes only. In particular:

- when the viewer requests a service in a different transport stream to that currently selected, the receiver should attempt to select the service irrespective of the service's running status as indicated in SDT_{other};
- selection of service components for immediate decoding shall be based on the components present in the PMT, rather than those listed in the component_descriptor in the EIT. If found, the corresponding component in the component_descriptor in the EIT (as identified by the component_tag) can be used to provide extra information about the component to assist the selection process. Selection of service components for future decoding should be based on the components listed in the component_descriptor in the EIT;
- the receiver shall store sufficient information in non-volatile memory, so that a service may be selected and decoded even if there is no SI present at all;
- the receiver should never 'hang' when an attempt to acquire an SI subtable fails.

Cross-carriage of information means that the receiver may have multiple paths to the same information. In general, information provided by 'actual' tables should be considered to be more reliable and up to date than information provided by 'other' tables.

9.4.5.2 Missing SI subtable

If acquisition of an SI subtable fails because the subtable cannot be found, the receiver should assume that the contents of that subtable have not changed.

Where the receiver has cached the information contained by that subtable, that information should be considered to be valid.

Where the receiver has not cached the information contained by that subtable, suitable benign defaults should be used:

- services and events should be considered to be running;
- components should be derived from PSI;
- text should default to null strings.

The following table lists the behaviour expected of the receiver in the event that the corresponding subtable is missing:

Table 33 – Receiver response to missing SI tables

| Missing subtable | Response by receiver |
|---|---|
| NITactual | All information in the NIT required to select a service should be cached in non-volatile memory by the receiver so that, provided that there are no changes to the network or bouquet configuration, the receiver will continue to operate normally. Changes to network configuration that result in the receiver being unable to acquire a multiplex or service should be handled by appropriate error/information messages to the viewer |
| SDTactual | All information in the SDT required to select a service should be cached in non-volatile memory by the receiver so that, provided that there are no changes to the location of the service, the receiver will continue to operate normally. Changes to service configuration that result in the receiver being unable to acquire the service (for example service not running) should be handled by appropriate error/information messages to the viewer |
| EITpfactual | The receiver shall use information in PSI to select and decode service components so that the loss of the EIT _{pf} will have no impact on the selection and decoding of the service. Where the viewer requests information about the event (for example start time, duration, name, etc.), the information fields should be left blank, or appropriate error/information messages should be displayed |
| TDT, TOT | The receiver shall maintain a real-time clock that shall continue to run in the absence of TDT (not necessarily spanning power-off or standby states). The receiver shall store the current offset value in non-volatile memory, and the next offset value and time of change, so that the change occurs correctly in the absence of the TOT |
| RST | The receiver shall not rely on the use of the RST and therefore shall not be aware that this table is missing |
| NIT _{other} , SDT _{other} and EIT _{pf other} | Information in the NIT _{other} and SDT _{other} required for presentation in the browser should be cached in non-volatile memory so that the presentation is not affected by the absence of these tables. Missing EIT _{pf other} should result in the associated fields in the browser being set to a null state, or appropriate error/information messages should be displayed |

9.4.5.3 Inconsistent SI information

A possible failure mode of the cross-carriage of SI is that information provided in one multiplex may differ from that referring to the same entity but provided by the SI in another multiplex. For example, these inconsistencies may be due to inconsistent subtable contents.

In addition, information may be present in more than one 'actual' subtable (for example a service may be referenced in the NIT and SDT), again leading to possibilities for inconsistent information.

To minimise the impact of inconsistent SI, the following rule applies:

- the receiver should acquire information that is not stored in non-volatile memory (for example event information) from any convenient source, and accept the information from the subtable most recently received.

9.4.5.4 Inaccurate SI information

The receiver shall discard invalid tables (for example incorrect CRC).

It is not expected that the receiver will be able to detect that SI information is inaccurate or inconsistent. Where any inaccuracies relate to information that is not stored in non-volatile memory, the impact will be to frustrate the viewer, but should not prevent the viewer from selecting services. However, where this relates to information that is stored in non-volatile memory, measures must be taken to ensure that the likelihood of the selection of a valid service being prevented are minimised. The mechanism for this is provided by the rules for the removal of services, transport streams and/or networks given in 9.4.5.3.

9.4.5.5 Excessive SI

The receiver may find that there is excessive SI due to

- excessive subtable repetition rates;
- rapid increment of subtable version numbers.

It is recommended that receivers are tolerant to a moderate amount of excessive SI.

9.5 User interface

This subclause describes the minimum set of views of the SI information that receivers are recommended to present to the user.

9.5.1 Presentation of text

9.5.1.1 Size of text fields

Broadcasters are advised not to exceed the maximum lengths for text fields (including multi-lingual variants where supplied) defined in the following table, as receivers may not be able to display excess characters. Note that the figures given are for the number of displayable characters (including spaces) required to represent the text field. The number of bytes required will depend on the use of control codes and whether one or two byte character representation is used.

Table 34 – Text field lengths

| Field name | Field length in displayable characters | Comments and examples |
|--------------------------------|--|--|
| Network Name | 24 | "Crystal Palace" |
| Service Provider Name | 20 | "BBC" |
| Service Name or Preferred Name | 32 | "BBC 1 North-East" Full name for display on set-up menus |
| | 8 | "BBC 1" A short version for display on browse and listing display. Shortened from full name by use of escape characters as defined in TR 101 211 |
| Event Name | 40 | "Casualty" Individual broadcasters are free to add an episode title to the title within the space, for example "Brit Girls: Marianne" |
| Short Event Description | 200 | "Out of control. When Mark steps in, he faces his own past and is forced to reveal a secret." Broadcasters must ensure that the text does not overflow the maximum descriptor size |
| Extended Event Text | 3984 | The extended event text complements the short event description |
| Component Description | 32 | "Casualty: guess the injury game" |

All name fields shall contain meaningful data. Description fields may be empty at the broadcaster's discretion, although it is recommended to fill them at all times for user convenience.

Where any text fields are transmitted with text lengths greater than those specified in the table, the receiver shall attempt to fit the text into the display area without truncation. If such a fit is not possible, the receiver shall take into account any escape codes, and display the broadcaster shortened version of the text. If no such codes are present, or if the shortened version does not fit either, the text shall be truncated, and this shall be made obvious, for example, by the use of an ellipsis (...) at the end of the text.

The receiver shall take into account carriage return characters, line feed characters and emphasis escape codes as defined in EN 300 468 and TR 101 211 where included in the text string.

9.5.1.2 Language selection

If multilingual descriptors are broadcast in one or more of the SI tables, the user interface screens shall choose the information for the language matching the user's preferred language.

9.5.1.3 Set of characters

Table A.1 lists the minimum set of characters in SI text fields that receivers shall be able to represent. Receivers are required to understand the following two formats for character encoding and transmission:

- ISO/IEC 6937 – the default character table for SI text (Table 00)
- ISO/IEC 8859-9 – SI character Table 05

See Annex A.

9.5.2 Information presentation

Receivers shall provide the user with a way to access the information discussed in this subclause. The screens described below are merely to illustrate the principles, and do not imply any proposed graphical or textual layout or display or any functionality. They should not

be considered to be the only screens which can be implemented. Receiver manufacturers are free to implement alternative methods of navigation and functionality which they consider to be “better” within the guidelines for information presentation laid out in this document.

9.5.2.1 Information screens

The following SI related information screens shall be supplied:

- information about the current event being decoded;
- overview of available events for one or more services;
- overview of available services.

These screens are defined below.

9.5.2.1.1 Information about the current event being decoded

When entering a service, some information about the event should be presented for a certain period, such as service name, event name, time interval of the event, current time. Optionally, more information can be presented, such as information about the genre and availability of subtitles and possible availability of multilingual audio or subtitles. Such a screen can also be presented when the user presses a button called ‘info’ or similar on the remote control.

If the preferred_name_identifier_descriptor is broadcast for the service, and supported by the receiver, the preferred service name shall be displayed instead of the ‘normal’ service name.

9.5.2.1.2 Overview of available events for one or more services

A list of current, current/next and/or future events (if EIT/schedule information is broadcast) for one or more services. If the preferred_name_identifier_descriptor is broadcast for the service and supported by the receiver, the preferred service name shall be displayed, not the ‘normal’ service name.

9.5.2.1.3 Overview of available services

The receiver user interface shall provide a display of all available services, possibly with network name and service provider name.

In such a service list screen, the ‘normal’ service_name shall be presented, and if supported by the broadcast and receiver, additionally a list of all of the preferred service names if this information is broadcast. In this case, it can be useful to indicate (for example using an alternate colour or an icon) which of these preferred service names is currently applicable.

Services which are not active (running_status field in SDT) at the current time can be indicated in an alternative manner (for example using an alternate colour or an icon).

9.5.2.2 Management of service list

The receiver user interface shall provide a method for maintaining the service list.

9.5.2.2.1 Service numbering

Receiver support of logical channel numbering is optional.

9.5.2.2.2 Initial ordering

In the case where the receiver supports logical channel numbers and logical channel numbers are broadcast, service numbers shall be allocated in accordance with 9.4.4. Otherwise, services should be given a service number by the receiver.

9.5.2.2.3 Re-initializing

The receiver shall allow the user to clear and re-build the service list. Note that this could be provided as part of another function, such as restoring some factory defaults.

9.5.2.2.4 Re-ordering by user

Users shall be able to re-order the list of services as they like.

9.5.2.2.5 Re-ordering by the system

If the receiver supports logical channel numbers and logical channel numbers are broadcast, service numbers shall be updated in accordance with 9.4.4. Otherwise, the following applies:

- when the list of services has to be updated (for example adding services, deleting services or changing regionalisation of services), the receiver should attempt to minimise the disturbance to the existing service list;
- if services are deleted, the receiver shall not automatically renumber the remaining services but keep remaining services on their previously assigned service number.

It is suggested to mark (for example using an alternate colour or an icon) those services with changed status (added, deleted,) in order to indicate these changes to the user.

9.5.3 Service navigation

Where the receiver supports “up/down” channel zapping, the order of the service list from 9.5.2.2 shall define the sequence in which services are accessed.

If not all services in the service list are running or accessible, there may be a need for on-screen messages and/or an automatic switch to an alternate service. See 9.3.2.6.

Some user interface consequences of these cases are discussed below.

9.5.3.1 Not running, no replacement

If a service is not running, and no service replacement service linkage descriptor is present in the SDT, the unavailability of the service shall be communicated to the user and the user shall be able to continue navigating.

9.5.3.2 Not running, replacement present

If a service is not running, and a service replacement service linkage descriptor is present, and if service linkage is supported by the receiver, then the receiver shall present this replacement service.

9.5.3.3 Navigation order when a replacement service is activated

In the above case where a replacement service is presented rather than the selected service, the logical navigation position in the ordered set of services shall remain that of the logically selected service, NOT its actual replacement.

This ensures that by navigating in a single direction, the user will eventually visit all available services.

In a similar manner, when the user has selected a service using the number keys, and a replacement service is presented rather than the selected service, the service to be selected when pressing “P+” or “P–” is the service following or preceding the originally selected service, NOT its actual replacement.

9.5.4 Display of time

Time shall always be displayed as local time.

The event following a time change should indicate on the display that the time has changed in a suitable manner.

Time shall be displayed either as the 24 hour clock, or as the 12 hour clock followed by either a.m. or p.m.

9.6 Recording devices

9.6.1 General

This subclause (9.6) is concerned with SI (and other triggering means) which are useful for a device which has the functionality to record (part of) an incoming transport stream.

This applies to both traditional analogue recorders (which record the analogue output of a digital receiver and are possibly controlled by the digital receiver (see 9.6.4)) and digital recorders (which record the compressed video and audio as it is broadcast).

9.6.2 Programming

Various methods are possible for defining the event(s) to be recorded:

- manual entry of service, date, start time and end time. All receivers shall support at least this method;
- when a receiver supports EIT_{schedule} information, it is recommended to support programming from the event overview screen and from an event information screen;
- other programming methods, for example from a teletext based EPG.

9.6.3 Execution of recording

The actual start and end time of an event may differ somewhat from the scheduled start and end times, due to operational situations in the broadcast centre.

The recording of the programmed events can be performed in various ways as indicated below.

a) Using literally the start and end time configured by the user.

In this case, the user is responsible for including any guard-band before and/or after the advertised timing of the event.

b) Using the start and end time of the event signalled in the SI schedule

In this case, it is recommended that the receiver adds a guard-band of several minutes before and after the signalled timing of the event.

c) As b), but also with monitoring of the EIT_{present} to get a more precise indication of the actual timing of the event.

If the broadcaster changes the `running_status` of the event in $EIT_{\text{following}}$ from “not running” to “starts in a few seconds” some time in advance of the actual start of the event and the rollover from $EIT_{\text{following}}$ to EIT_{present} , the recording device could use this indication to start the recording.

d) Where PDC triggering is supported by the broadcast.

Using a PDC trigger carried in a teletext stream to provide a precise indication of the actual transmission period of an event.

This requires the digital receiver (and possibly the analogue recorder) to have access to the PIL (Programme Identification Label) from PDC for each event. This PIL normally carries the local announced broadcast time (day, month, hour, minute) identifying an event.

In order to make this feasible, the broadcaster must broadcast the PIL labels for the events in the EIT using the PDC descriptor (Annex B). This descriptor is placed in the descriptor loop of an event in the EIT. This provides a binding between the SI identification of an event (original network ID/service ID/event ID) and the PDC identification (PIL).

e) Where PDC descriptors are in the EIT and EIT times are monitored.

As in case d) but the trigger event is the SI time base rather than the teletext stream. This mode of operation relies on broadcasters providing accurate EIT timing, particularly with regard to the roll over from following to present of an event.

NOTE In this standard, the RST is not a required part of the broadcast signal and so cannot be relied upon by receivers as a method of controlling recording. In general, the specification of the RST is such that in a compliant broadcast, the transition of EIT for an event from following to present is only a second or so different from when an RST could be transmitted.

9.6.4 Control of analogue recorders

It is recommended to provide a method for automatically controlling analogue video recorders for example using infra-red control or via commands over the peritelevision connection; if no such method is available, the end user has to program the recording event both in the digital receiver and in the analogue recorder.

Alternative methods to indicate the time window to the analogue recorder are:

- select input signal and start instant recording (at the actual time of recording);
- program the recording of scheduled events or a time window of a service (in advance).

To ensure energy efficiency when controlling recording:

- the receiver shall be able to wake from stand-by to support recording and then return to stand-by when the recording is complete;
- if control of the analogue recorder is implemented, the receiver shall be able to wake the recorder from stand-by at the start of the recording time interval and return it to stand-by afterwards.

10 Subtitles

10.1 General

This standard allows subtitles to be delivered to receivers using DVB subtitles as in EN 300 743. All receivers conforming to this standard shall provide access to these subtitles.

One of the objectives of the approach described here is to allow broadcasters to rely on DVB subtitles where in-vision subtitles might have been used previously for translation.

10.2 Broadcast specifications

10.2.1 DVB subtitles

DVB subtitles, when broadcast, shall be encoded according to EN 300 743 as corrected, clarified and extended by the D-Book version 3.0 with the following additional requirement:

- the 'End of display set' (EDS) segment shall be mandatory in all broadcasts;
- the subtitles for HD video services may include a Display Definition Segment (DDS).

The subtitle specification from the D-Book, is reproduced in Annex C.

Signalling shall be as specified in 9.2.3.

10.2.2 Signalling

Subtitling streams shall be signalled in the program map table using stream type 0x06 indicating PES packet private data.

The subtitling descriptor defined in the DVB SI specification EN 300 468 enables different subtitling streams to be distinguished by their ISO-639_language_code, subtitling_type, composition_page_id and ancillary_page_id.

- If no ancillary page is transmitted, the values of ancillary_page_id and composition_page_id in the subtitling descriptor shall be the same.
- The subtitling_type “normal” or “normal for display on a high definition monitor” shall be used for subtitles intended primarily to provide translation. The latter value shall be used when the subtitle stream includes a DDS.
- Any subtitling_type referring to EBU teletext or VBI data (i.e. 0x01 to 0x03) should not be used in the subtitling descriptor. Signalling of teletext subtitling shall be done using the teletext_descriptor (see 9.2.3).
- A type “normal” subtitle stream may be substantially empty, only having brief periods of subtitling where the audio channel is carrying a foreign language.

NOTE For example, during a news programme foreign news items may have only a foreign language soundtrack. During such items the subtitle stream may carry a subtitles providing translation while for other items, the subtitles stream might logically exist, but be empty.

In this scenario the main programme audio stream (type undefined) will normally be signalled with the natural language of the TV service, even if it periodically carries foreign speech.

- A subtitle stream “for the hearing impaired” for a fully subtitled service will normally contain subtitles comparable to the verbal content of the soundtrack.

An exception to this occurs where the programme has in-vision subtitles and the “for the hearing impaired” subtitle stream is used to convey a visual representation of sound effects, etc.

- The signalling of the subtitle stream should change no more frequently than on event boundaries. Finely timed changes in the subtitle stream should be implemented by changes to the subtitle data in the stream rather than changing the stream signalling.

10.2.3 DDS

A Display Definition Segment shall only be included in the subtitle stream when the video is HD. The maximum display_width shall be 1919 and the maximum display_height shall be 1079.

10.2.4 Recommendation

It is recommended that broadcasts do not provide subtitles in the same language as in-vision subtitles.

10.3 Receiver functions

10.3.1 Background

Subtitles serve more than one purpose:

- they can be used to translate the dialogue of foreign language programme content;
- they make dialogue available to those with hearing impairments;
- they can provide a visual representation of sound effects, etc. to those with hearing impairments.

The process that controls the presentation of subtitles should accommodate these different needs.

NOTE 1 It is recognised that the relative emphasis on subtitles for translation vs. hearing impairment varies significantly between countries.

The intention of the scheme described here is that the control of the subtitle decoder within the receiver should be relatively static.

NOTE 2 For example, where the user's need is for subtitles for translation, the receiver should be able to activate a subtitle decoder operating continuously alongside the video and audio decoders. The broadcaster then addresses this decoder by sending subtitle data or not, depending on the needs of the programme.

Possible user requirements include:

- a user with hearing disability wants subtitles presented in their preferred language by default;
- a user with normal hearing wants to be able to periodically activate subtitles in their preferred language, for example, when the background noise is high;
- a user wants subtitles to appear if the language of the audio track is less comfortable to them than the language one of the provided subtitle streams (i.e. for translation).

It is undesirable to display subtitles over a program that already has in-vision subtitles.

In the case where both DVB and teletext subtitles are available with the same language and type parameters then, displaying the DVB subtitles has priority over displaying the teletext subtitles.

10.3.2 User control of receiver behaviour

See 9.3.2.3.

10.3.3 Support for DDS

It is recommended that advanced receivers support Display Definition Segments.

11 VBI based services

11.1 General

This standard allows teletext data to be transmitted in accordance with EN 300 472, EN 300 468 and TR 101 211. Receivers conforming to this standard should provide a method to make basic teletext services available to the user.

11.2 Broadcast specifications

Teletext broadcasts, if any, shall be in accordance with EN 300 472.

The signalling associated with these broadcasts shall conform to the requirements of EN 300 468 and TR 101 211.

The teletext data, may either be associated with a TV service as a component of that service or may exist as a viewable teletext service in its own right.

There shall be at most one teletext stream associated with each service.

11.3 Receiver functions

11.3.1 Processing capabilities

11.3.1.1 Data rates

The facility to decode or re-insert teletext data is provided primarily to allow the transcoding of pre-existing analogue video + teletext domestic TV services into the DVB domain. Receivers are not required to address full raster/high data rate teletext services.

11.3.1.2 STBs

Set top boxes should support re-insertion of the teletext data into the VBI of their analogue outputs. Optionally, they may also include a teletext decoder supporting at least teletext level 1.5 (as defined in ETS 300 706).

11.3.1.3 IDTVs

As a minimum, IDTVs are recommended to include a teletext decoder supporting at least teletext level 1.5 (as defined in ETS 300 706).

11.3.2 Control

11.3.2.1 VBI insertion

Where the VBI data is re-inserted into the analogue output of the receiver, activation of this process is a side effect of channel selection. No direct user control is required.

11.3.2.2 Local decoding

Where the VBI data is decoded by the receiver, the user controls are:

- activation of the teletext decoder function (except for teletext only services where this is a side effect of service selection);
- navigation within the teletext service (for example page number selection).

It is sufficient for the receiver to rely on user navigation of the teletext service.

It is optional for the receiver to take advantage of the possible page type information in the `teletext_descriptor`.

NOTE This standard does not place detailed requirements on the SI signalling associated with teletext services. Therefore, receivers should not rely on particular information in the `teletext_descriptor`.

11.4 Extended VBI format support

EN 301 775 provides a VBI data delivery specification that extends that specified in EN 300 472. Support for reception of signals encoded in accordance with this new specification is optional.

Only some of the additional data formats described in EN 301 775 are considered relevant to receivers conforming to this standard:

- VPS;
- WSS.

Other additional formats (for example inverted teletext, closed captioning, monochrome samples) are not relevant.

11.4.1 VPS

VPS data can be remodulated into the analogue output of the receiver (where appropriate) to provide one method for controlling an attached analogue video recorder.

11.4.2 WSS

WSS data as conveyed in EN 301 775 may optionally be remodulated on to the analogue output of the receiver (where appropriate) to signal the video format to the attached display or recording device. This broadcast WSS data will only be appropriate if no “decoder format conversion” has been performed (see 6.4.4.3).

The preferred broadcast signalling for video format is the “active format description” (see 6.4.4).

11.4.3 Teletext and teletext subtitles

The preferred broadcast method for traditional teletext data and teletext subtitles shall be EN 300 472.

12 RF-part and channel decoder

12.1 General

This clause covers the parameters and functions related to the RF and channel decoder parts of a terrestrial receiver. The input signal for this part is a signal from a terrestrial transmitter, broadcasting in accordance with EN 300 744. The output signal is a TS-stream for the CA /Demux parts.

The digital transmissions may share frequency bands with other transmissions; successful reception will depend on, for example network configuration, channel characteristics, time varying interference from other “analogue ” or “digital ” transmitters and the receiver performance. The transmission networks of DVB-T may include single frequency networks (SFN).

12.2 Frequencies and channel bandwidth

The receiver shall be able to receive all channels in the VHF band III and/or UHF bands IV and V. An example of channel centre frequencies and offsets is given in Annex D.

12.3 DVB-T modes

The receiver shall be capable of correctly demodulating all modes specified in EN 300 744. The front end shall therefore be able to work with any combination of

- constellation (QPSK, 16-QAM, 64-QAM, hierarchical 16-QAM, hierarchical 64-QAM);
- code rate (1/2, 2/3, 3/4, 5/6 or 7/8);
- guard interval (1/4, 1/8, 1/16 or 1/32);
- transmission mode (2K or 8K);
- where applicable α (1, 2, or 4).

During channel search, the receiver shall automatically detect which mode is being used. The receiver, when fed with one of the hierarchical modes (16-QAM or 64-QAM) specified in EN 300 744, is recommended to be capable of correctly demodulating whichever of the high or low priority streams is selected by the user.

12.4 Tuning procedure

The receiver shall be able to provide a channel search. It shall also be able to receive information regarding tuning parameters found in PSI/SI (see 9.4.2).

12.5 Change of modulation parameters

Receivers shall automatically detect a change of modulation parameters (constellation, code rate, guard interval and transmission mode) for a channel.

12.6 Connector

See Clause 16.

12.7 Performance

12.7.1 Failure point criteria

Two different failure point criteria can be used:

- a) reference BER, defined as $BER = 2 \times 10^{-4}$ after Viterbi decoding;
- b) picture failure point defined as the minimum C/N or C/I value for more than 1 TS-packet error in 10 s plus a delta value according the Table 35 and depending on the measurement. This is more convenient for some of the measurements than the normal reference BER criterion, which might be unreachable.

Table 35 – Delta values between picture failure point and reference BER

| Measurement | Chapter | Delta dB |
|------------------------------------|---------|-------------|
| C/N in AWGN channel | 12.7.2 | 1,3 |
| Minimum input level | 12.7.3 | 1,3 |
| Immunity to other channels | 12.7.5 | 2,0 |
| Immunity to co-channel | 12.7.6 | 2,0 |
| SFN-multipath | 12.7.7 | 2,0 |
| MFN-multipath | 12.7.8 | 2,0 |
| C/N in fixed and portable channels | Annex F | 1,3 |

12.7.2 C/N performance

The receiver should have the performance given in Table 36 when noise (N) is applied together with the wanted carrier (C) in a signal bandwidth of 7,61 MHz. The values are calculated using the noise model given in Annex E with an implementation margin of 2,5 dB and receiver excess noise source value P_x of -33 dBc. An ideal transmitter is assumed. An example of the effects in transmitter degradation on the C/N-values is given in Annex F.

Table 36 – C/N (dB) for reference BER

| Modulation | Code rate | Gaussian | Fixed | Portable |
|------------|-----------|----------|-------|----------|
| QPSK | 1/2 | 5,6 | 6,1 | 7,9 |
| QPSK | 2/3 | 7,4 | 8,2 | 10,9 |
| QPSK | 3/4 | 8,4 | 9,3 | 13,2 |
| QPSK | 5/6 | 9,4 | 10,5 | 15,7 |
| QPSK | 7/8 | 10,2 | 11,2 | 19,0 |
| 16-QAM | 1/2 | 11,3 | 12,1 | 13,8 |
| 16-QAM | 2/3 | 13,7 | 14,2 | 16,8 |
| 16-QAM | 3/4 | 15,1 | 15,6 | 19,4 |
| 16-QAM | 5/6 | 16,1 | 17,0 | 22,1 |
| 16-QAM | 7/8 | 16,5 | 17,6 | 26,1 |
| 64-QAM | 1/2 | 17,0 | 17,3 | 18,7 |
| 64-QAM | 2/3 | 19,2 | 19,8 | 22,1 |
| Modulation | Code rate | Gaussian | Fixed | Portable |
| 64-QAM | 3/4 | 20,8 | 21,4 | 24,8 |
| 64-QAM | 5/6 | 22,1 | 22,9 | 29,4 |
| 64-QAM | 7/8 | 23,0 | 24,0 | 33,9 |

NOTE 1 Reference BER is defined as $BER = 2 \times 10^{-4}$ after Viterbi decoding.

NOTE 2 The figures in EN 300 744 are all the result of early simulation work, and could change as a result of improved simulations.

NOTE 3 The figures for the fixed reception ("Ricean ") and portable reception ("Rayleigh ") channels make use of the information given in EN 300 744. These particular channels are too complicated for practical implementation and one possible simpler implementation is given in Annex G.

12.7.3 Minimum receiver signal input levels

The receiver shall have a noise figure better than 8 dB.

The receiver should provide reference BER for the minimum signal levels (P_{min}) stated below and higher.

$$P_{min} = -97,2 \text{ dBm} + C/N \text{ [dB] [for 8 MHz]}$$

$$P_{min} = -97,8 \text{ dBm} + C/N \text{ [dB] [for 7 MHz]}$$

where C/N is specified in Table 36.

NOTE These figures are based on an ideal transmitter. An example of non-ideal transmitter figures can be achieved using the C/N-table in Annex F.

The D Book version 5.0 chapter 9.13.3 gives further useful information on the power levels.

12.7.4 Maximum input level

The receiver shall be able to handle DVB-T signals up to a level of -35 dBm while providing the performance specified in this subclause. Maximum tolerated level for analogue signals is -25 dBm. Both levels are valid for receivers operating on all DVB-T modes.

12.7.5 Immunity to analogue and/or digital signals in other channels

The following performance is only provided when the input level restrictions in 12.7.4 apply and the unwanted signal is at the highest allowed level.

The interfering signals are defined in Annex H.

Table 37 – Immunity to analogue signals on other channels

| Mode | N±1 PAL G or I1 | N±1 PAL B ^a | N-1 SECAM L | N+1 SECAM L | Image SECAM L | N±m (m≠1) and Image for PAL B/G/I1 |
|------------------------------|--------------------|---------------------------|----------------|----------------|------------------|---|
| 2k/8k 64QAM CR=2/3 GI=All | 35 dB | 33 dB | 30 dB | 33 dB | 45 dB | 46 dB |
| 2k/8k 64QAM CR=3/4 GI=All | 35 dB | 33 dB | 30 dB | 33 dB | 42 dB | 43 dB |
| 2k/8k 16QAM CR=1/2 GI=All | 38 dB | 36 dB | 30 dB | 36 dB | 55 dB | 56 dB |
| 2k/8k 16QAM CR=2/3 GI=All | 38 dB | 36 dB | 30 dB | 36 dB | 50 dB | 51 dB |
| 2k/8k 16QAM CR=3/4 GI=All | 37 dB | 35 dB | 29 dB | 35 dB | 49 dB | 50 dB |

^a Note that if PAL B N-1 is with NICAM sound, the digital channel on N cannot be used without offset, because of the overlapping spectrums.

Table 38 – Immunity to digital signals on other channels

| Mode | N±1 | N±m (m≠1) except Image | Image |
|------------------------------|-------|---------------------------|-------|
| 2k/8k 64QAM CR=2/3 GI=All | 27 dB | 40 dB | 31 dB |
| 2k/8k 64QAM CR=3/4 GI=All | 27 dB | 40 dB | 29 dB |
| 2k/8k 16QAM CR=1/2 GI=All | 29 dB | 40 dB | 39 dB |
| 2k/8k 16QAM CR=2/3 GI=All | 29 dB | 40 dB | 36 dB |
| 2k/8k 16QAM CR=3/4 GI=All | 29 dB | 40 dB | 35 dB |

The D Book version 5.0 chapter 9.14 gives further useful information on the immunity requirements.

12.7.6 Immunity to co-channel interference from analogue TV signals

The immunity for interference from analogue TV-signal is specified as the minimum carrier to interference ratio, C/I, required for reception.

The interfering analogue signal is defined in 12.7.5. The digital signal should be at the -50 dBm level.

Table 39 – Immunity to co-channel interference from analogue signals

| Mode | PAL B/G/I1 | SECAM |
|---------------------------|------------|-------|
| 2k/8k 64QAM CR=2/3 GI=All | 4 dB | 5 dB |
| 2k/8k 64QAM CR=3/4 GI=All | 7 dB | 8 dB |
| 2k/8k 16QAM CR=1/2 GI=All | -6 dB | -5 dB |
| 2k/8k 16QAM CR=2/3 GI=All | -1 dB | 0 dB |
| 2k/8k 16QAM CR=3/4 GI=All | 0 dB | 1 dB |

12.7.7 Guard interval utilisation in single frequency networks

For the modes:

{8K, 64-QAM, R =2/3, GI = All },

{8K, 64-QAM, R =3/4, GI = All },

{8K, 16-QAM, R =1/2, GI = All },

{8K, 16-QAM, R =2/3, GI = All },

{8K, 16-QAM, R =3/4, GI = All }.

The receiver shall provide the reference BER when the channel contains two static paths with relative delay from 0,2 μ s up to 0,9 times the guard interval length independently of the relative amplitudes and phases of the two paths. No noise is added.

12.7.8 MFN multipath performance

12.7.8.1 Performance with long echoes

The receiver shall provide the reference BER when $C/N \geq 24,2$ dB with the mode 2K 64-QAM, R=2/3, GI=1/32, when the following channel profile is applied. Only one mode is used for testing, and this is thought to represent the overall echo performance of the chip.

Table 40 – Long echo test profile

| Tap | Delay μ s | Relative attenuation dB |
|-----|------------------|----------------------------|
| 1 | 0 | 0 |
| 2 | 5 | 9 |
| 3 | 14 | 22 |
| 4 | 35 | 25 |
| 5 | 54 | 27 |
| 6 | 75 | 28 |

12.7.8.2 Performance with short echoes

The receiver shall provide the reference BER when $C/N \geq 24,2$ dB with the mode 2K 64-QAM, R=2/3, GI=1/32, when the following channel profile is applied. Only one mode is used for testing, and this is thought to represent the overall echo performance of the chip.

Table 41 – Short echo test profile

| Tap | Delay μ s | Relative attenuation dB |
|-----|------------------|----------------------------|
| 1 | 0 | 2,8 |
| 2 | 0,05 | 0 |
| 3 | 0,4 | 3,8 |
| 4 | 1,45 | 0,1 |
| 5 | 2,3 | 2,6 |
| 6 | 2,8 | 1,3 |

13 Conditional access and the common interface

13.1 General

Digital terrestrial receivers should be prepared to receive existing and future pay-TV services. This requires that the receiver can accommodate conditional access (CA) systems chosen by service providers.

13.2 Minimum requirements

To enable receivers with a built-in CA system to receive additional services via simulcrypt techniques the DVB common scrambling algorithm shall be implemented according to ETR 289. It is recommended that CA modules support simulcrypt on the same basis.

In order to allow later introduction of Conditional Access, it is recommended to implement at least one DVB Common Interface (CI) connection complying with the following ETSI and CENELEC standards:

- A011 rev.1
- EN 50221
- ETR 289
- R206-001
- TS 101 699

Profile 2 as defined in TS 101 699 shall be implemented as minimum. With respect to features being mandatory or optional, the guidelines in R206-001 shall only be interpreted as further refinements on EN 50221 and TS 101 699 to improve interoperability, not as functional extensions to EN 50221 and TS 101 699. This is also stipulated in the profile definitions of TS 101 699.

If the CA system on the CI module requires a smart-card reader, this reader shall be implemented on the CI module.

13.2.1 Analogue Copy Protection Resource

Receivers may provide a Copy Protection resource as defined in TS 101 699 and operating at least the specific protocol described here.

13.2.1.1 CopyProtectionID

The Copy Protection resource shall at least recognise copy protection messages with CopyProtectionID of 0x00D07F.

13.2.1.2 CP_query

As specified in TS 101 699.

13.2.1.3 CP_reply

As specified in TS 101 699.

13.2.1.4 CP_command

This standard uses a single byte message carried in the CPCommandByte field described by TS 101 699. The encoding of this byte is as follows:

- the value 0 commands 'deactivate copy protection';
- the value 1 commands 'activate copy protection'.

Other values of CPCommandByte are reserved. The meaning of command byte strings longer than 1 byte is reserved. Receivers shall consider commands with values other than 0 or 1, and lengths other than a single byte, as an error.

13.2.1.5 CP_response

The cp_response_bytes described by TS 101 699 encode the reply of the receiver to the command. This standard uses a single byte message:

- 1 - means 'command understood and implemented'
- 0 - means 'error'

The meaning of other values or longer strings is reserved.

13.2.1.6 Implementation of copy protection

This standard does not address the method used by the receiver to make its output non-recordable.

13.2.1.7 Default state

The default state for the receiver shall be with copy protection inactive. Copy protection only becomes active following a CP_command to activate it.

14 System software update

14.1 General

Receiver software is increasingly complex. In order to guarantee the functionality of a receiver as well as increasing its functionality once deployed in the field a software update service is required.

14.2 Minimum requirements

The system software update is specified in TS 102 006.

Two profiles for software update services with respect to the signalling of the service are defined in TS 102 006:

- simple profile software update services;
- update notification table enhanced profile software update services.

Receivers able to support over air software download shall at least support the simple profile. It is highly recommended that receivers support the enhanced profile, in particular for receivers that may require more frequent updating.

14.3 Recommendations for SSU operators

Network operators should make available at least 200 kbit/s for a multiplex with high coverage. It is recommended that network operators follow DVB recommendations regarding transfer of download data as indicated by TS 102 006.

15 Application Programming Interface (API)

The API to be implemented inside a receiver is not specified in this document.

16 Connectors

16.1 Standard receivers

Receivers shall have one input tuner connector, type: IEC female in accordance with IEC 61169-2. The input impedance shall be 75 Ω . The connector can, as an optional feature, provide DC-power supply for an active indoor antenna. This output should have the following characteristics:

- 5 V, maximum 30 mA DC voltage, the centre contact as a positive terminal;
- the output should be short circuit proof.

The DC-voltage can be switchable by software, with the default state being “off”.

Standard receivers shall have at least one peritelevision connector (EN 50049-1) with support for CVBS and RGB video, stereo audio, fast blanking (on pin 16) and slow blanking (on pin 8).

If other connectors are provided, they shall conform to any applicable parts of 16.2.

16.2 Advanced receivers

Advanced receivers shall have as a minimum the connectors as specified in 16.1 (HD video will have to be downscaled to SD to be carried over the peritelevision connector – see 5.3.5.3).

16.2.1 Without display

Advanced receivers without a display for video reproduction shall also have the following:

- optionally, an RF loop through connection. If provided, this connector shall be IEC male in accordance with IEC 61169-2, Part 2;
- optionally, RCA connectors for output of analogue YPbPr video (as per CEA 770.3);
- an HDMI output⁸ according to HDMI- HDMI Licensing, LLC, “High-Definition Multimedia Interface” incorporating HDCP content protection according to HDCP - Intel, “High-Bandwidth Digital Content Protection System”. The receiver shall allow the user to set the video format on the HDMI output either to a fixed format or to follow the format of the decoded video.
- An RCA stereo output connector carrying one of the following:
 - a mono or stereo signal, in the case of the received audio component being mono or stereo;
 - a two channel downmixed signal, in the case of the received audio component being multi-channel.
- A consumer electrical or optical digital audio output according to IEC 60958-1 and the applicable parts of IEC 61937 (this may be omitted when the receiver provides a minimum 5 channel audio reproduction system capable of driving at least 5 speakers)⁹. Receivers shall allow the user to add a delay to the audio output of up to 250 ms to compensate for video processing delays in the external display device.

The digital audio stream outputs shall conform to 7.3.6, except that the HDMI audio output may be limited to a maximum of two channels when the receiver provides a minimum 5 channel audio reproduction system capable of driving at least 5 speakers.

⁸ The receiver should rely on the (E-)EDID information returned by the display device - indicating the video formats the display device can receive and render - to stay within the capabilities of and avoid interoperability issues with non-HD/non-“HD ready” display devices.

⁹ This connector is optional for receivers that only support SD services.

16.2.2 With display

Advanced receivers with a display for video reproduction shall have a consumer electrical or optical digital audio output according to IEC 60958-1 and the applicable parts of IEC 61937, except that it may be omitted when the receiver provides a minimum 5 channel audio reproduction system capable of driving at least 5 speakers¹⁰. The digital audio stream shall conform to 7.3.6.

¹⁰ This connector is optional for receivers that only support SD services.

Annex A (normative)

SI character set

This annex tabulates the minimum character codes that receivers support for their presentation of text delivered by SI.

NOTE The design of this table intends, as far as possible, to ensure that it is a subset of the character set being considered for use in the DVB multimedia home platform. However, at the time of writing, both specifications are under review, so some minor adjustments may be required.

A.1 Set of languages supported

The set of languages supported by the characters listed in Table A.1 is:

| | | | |
|-----------|-------------|----------------|--------------|
| Afrikaans | Estonian | Italian | Scots Gaelic |
| Albanian | Faroese | Lapp (Sami) | Slovak |
| Basque | Finnish | Latvian | Slovene |
| Breton | French | Lithuanian | Sorbian |
| Catalan | Frisian | Maltese | Spanish |
| Croat | Galician | Norwegian | Swedish |
| Czech | German | Occitan | Turkish |
| Danish | Greenlandic | Polish | Welsh |
| Dutch | Hungarian | Portuguese | |
| English | Icelandic | Rhaeto-Romanic | |
| Esperanto | Irish | Romanian | |

A.2 Structure of character table

A.2.1 ISO/IEC 6937

The first column of Table A.1 shows the minimum supported character codes when signalled using the ISO/IEC 6937 character set. ISO/IEC 6937 allows characters to be coded using either 1 or 2 bytes. This is the default character set for text fields in DVB SI.

The set shown is the full set defined in the standard augmented by a small number of additional characters required to support particular languages. These additional characters (labelled with footnotes b) and c) in the table) have 16 bit Unicode representations 0x01CD, 0x01CE, 0x1E80-0x1E85 and 0x1EF2-0x1EF3.

A.2.2 ISO/IEC 8859-9

The second column of Table A.1 shows the minimum supported codes based on the ISO/IEC 8859-9 character set. This is the full set defined in the standard.

As described in EN 300 468, strings shall start with the byte 0x05 to select this character table.

A.2.3 Character name

These character names are those defined by Unicode.

A.2.4 UCS-2

The right-hand column of Table A.1 lists the UCS2 (16 bit Unicode) equivalent of the character codes. This is informative and is provided as a “common interface” to other possible applications of the character set (for example for mapping into standard fonts or APIs). Receivers are not required to support UCS2 encoded text.

A.2.5 Count

The right most column shows a character count. This is not a normative part of the table. It is provided just to count the number of characters in the table.

A.2.6 Character table

NOTE The third column provides in some cases an example of the character when it is displayed. Blank cells indicate that no example is given.

Table A.1 – Allowed character codes in SI text fields

| ISO/IEC 6937 | ISO/IEC 8859-9 | | Character name | UCS2 | |
|--------------|----------------|----|-------------------|--------|-----|
| 0x20 | 0x20 | | Space | 0x0020 | 1. |
| 0x21 | 0x21 | ! | Exclamation Mark | 0x0021 | 2. |
| 0x22 | 0x22 | “ | Quotation Mark | 0x0022 | 3. |
| 0x23 | 0x23 | # | Number Sign | 0x0023 | 4. |
| 0x24 | 0x24 | \$ | Dollar Sign | 0x0024 | 5. |
| 0x25 | 0x25 | % | Percent Sign | 0x0025 | 6. |
| 0x26 | 0x26 | & | Ampersand | 0x0026 | 7. |
| 0x27 | 0x27 | ‘ | Apostrophe | 0x0027 | 8. |
| 0x28 | 0x28 | (| Left Parenthesis | 0x0028 | 9. |
| 0x29 | 0x29 |) | Right Parenthesis | 0x0029 | 10. |
| 0x2A | 0x2A | * | Asterisk | 0x002A | 11. |
| 0x2B | 0x2B | + | Plus Sign | 0x002B | 12. |
| 0x2C | 0x2C | , | Comma | 0x002C | 13. |
| 0x2D | 0x2D | – | Hyphen-Minus | 0x002D | 14. |
| 0x2E | 0x2E | . | Full Stop | 0x002E | 15. |
| 0x2F | 0x2F | / | Solidus | 0x002F | 16. |
| 0x30 | 0x30 | 0 | Digit Zero | 0x0030 | 17. |
| 0x31 | 0x31 | 1 | Digit One | 0x0031 | 18. |
| 0x32 | 0x32 | 2 | Digit Two | 0x0032 | 19. |
| 0x33 | 0x33 | 3 | Digit Three | 0x0033 | 20. |
| 0x34 | 0x34 | 4 | Digit Four | 0x0034 | 21. |
| 0x35 | 0x35 | 5 | Digit Five | 0x0035 | 22. |
| 0x36 | 0x36 | 6 | Digit Six | 0x0036 | 23. |
| 0x37 | 0x37 | 7 | Digit Seven | 0x0037 | 24. |
| 0x38 | 0x38 | 8 | Digit Eight | 0x0038 | 25. |
| 0x39 | 0x39 | 9 | Digit Nine | 0x0039 | 26. |
| 0x3A | 0x3A | : | Colon | 0x003A | 27. |
| 0x3B | 0x3B | ; | Semicolon | 0x003B | 28. |
| 0x3C | 0x3C | < | Less-Than Sign | 0x003C | 29. |

| ISO/IEC 6937 | ISO/IEC 8859-9 | | Character name | UCS2 | |
|--------------|----------------|---|------------------------|--------|-----|
| 0x3D | 0x3D | = | Equals Sign | 0x003D | 30. |
| 0x3E | 0x3E | > | Greater-Than Sign | 0x003E | 31. |
| 0x3F | 0x3F | ? | Question Mark | 0x003F | 32. |
| 0x40 | 0x40 | @ | Commercial At | 0x0040 | 33. |
| 0x41 | 0x41 | A | Latin Capital Letter A | 0x0041 | 34. |
| 0x42 | 0x42 | B | Latin Capital Letter B | 0x0042 | 35. |
| 0x43 | 0x43 | C | Latin Capital Letter C | 0x0043 | 36. |
| 0x44 | 0x44 | D | Latin Capital Letter D | 0x0044 | 37. |
| 0x45 | 0x45 | E | Latin Capital Letter E | 0x0045 | 38. |
| 0x46 | 0x46 | F | Latin Capital Letter F | 0x0046 | 39. |
| 0x47 | 0x47 | G | Latin Capital Letter G | 0x0047 | 40. |
| 0x48 | 0x48 | H | Latin Capital Letter H | 0x0048 | 41. |
| 0x49 | 0x49 | I | Latin Capital Letter I | 0x0049 | 42. |
| 0x4A | 0x4A | J | Latin Capital Letter J | 0x004A | 43. |
| 0x4B | 0x4B | K | Latin Capital Letter K | 0x004B | 44. |
| 0x4C | 0x4C | L | Latin Capital Letter L | 0x004C | 45. |
| 0x4D | 0x4D | M | Latin Capital Letter M | 0x004D | 46. |
| 0x4E | 0x4E | N | Latin Capital Letter N | 0x004E | 47. |
| 0x4F | 0x4F | O | Latin Capital Letter O | 0x004F | 48. |
| 0x50 | 0x50 | P | Latin Capital Letter P | 0x0050 | 49. |
| 0x51 | 0x51 | Q | Latin Capital Letter Q | 0x0051 | 50. |
| 0x52 | 0x52 | R | Latin Capital Letter R | 0x0052 | 51. |
| 0x53 | 0x53 | S | Latin Capital Letter S | 0x0053 | 52. |
| 0x54 | 0x54 | T | Latin Capital Letter T | 0x0054 | 53. |
| 0x55 | 0x55 | U | Latin Capital Letter U | 0x0055 | 54. |
| 0x56 | 0x56 | V | Latin Capital Letter V | 0x0056 | 55. |
| 0x57 | 0x57 | W | Latin Capital Letter W | 0x0057 | 56. |
| 0x58 | 0x58 | X | Latin Capital Letter X | 0x0058 | 57. |
| 0x59 | 0x59 | Y | Latin Capital Letter Y | 0x0059 | 58. |
| 0x5A | 0x5A | Z | Latin Capital Letter Z | 0x005A | 59. |
| 0x5B | 0x5B | [| Left Square Bracket | 0x005B | 60. |
| 0x5C | 0x5C | \ | Reverse Solidus | 0x005C | 61. |
| 0x5D | 0x5D |] | Right Square Bracket | 0x005D | 62. |
| 0x5F | 0x5F | _ | Low Line | 0x005F | 63. |
| 0x61 | 0x61 | a | Latin Small Letter A | 0x0061 | 64. |
| 0x62 | 0x62 | b | Latin Small Letter B | 0x0062 | 65. |
| 0x63 | 0x63 | c | Latin Small Letter C | 0x0063 | 66. |
| 0x64 | 0x64 | d | Latin Small Letter D | 0x0064 | 67. |
| 0x65 | 0x65 | e | Latin Small Letter E | 0x0065 | 68. |
| 0x66 | 0x66 | f | Latin Small Letter F | 0x0066 | 69. |
| 0x67 | 0x67 | g | Latin Small Letter G | 0x0067 | 70. |
| 0x68 | 0x68 | h | Latin Small Letter H | 0x0068 | 71. |
| 0x69 | 0x69 | i | Latin Small Letter I | 0x0069 | 72. |

| ISO/IEC 6937 | ISO/IEC 8859-9 | | Character name | UCS2 | |
|--------------|----------------|--------------|--|--------|------|
| 0x6A | 0x6A | j | Latin Small Letter J | 0x006A | 73. |
| 0x6B | 0x6B | k | Latin Small Letter K | 0x006B | 74. |
| 0x6C | 0x6C | l | Latin Small Letter L | 0x006C | 75. |
| 0x6D | 0x6D | m | Latin Small Letter M | 0x006D | 76. |
| 0x6E | 0x6E | n | Latin Small Letter N | 0x006E | 77. |
| 0x6F | 0x6F | o | Latin Small Letter O | 0x006F | 78. |
| 0x70 | 0x70 | p | Latin Small Letter P | 0x0070 | 79. |
| 0x71 | 0x71 | q | Latin Small Letter Q | 0x0071 | 80. |
| 0x72 | 0x72 | r | Latin Small Letter R | 0x0072 | 81. |
| 0x73 | 0x73 | s | Latin Small Letter S | 0x0073 | 82. |
| 0x74 | 0x74 | t | Latin Small Letter T | 0x0074 | 83. |
| 0x75 | 0x75 | u | Latin Small Letter U | 0x0075 | 84. |
| 0x76 | 0x76 | v | Latin Small Letter V | 0x0076 | 85. |
| 0x77 | 0x77 | w | Latin Small Letter W | 0x0077 | 86. |
| 0x78 | 0x78 | x | Latin Small Letter X | 0x0078 | 87. |
| 0x79 | 0x79 | y | Latin Small Letter Y | 0x0079 | 88. |
| 0x7A | 0x7A | z | Latin Small Letter Z | 0x007A | 89. |
| 0x7B | 0x7B | { | Left Curly Bracket | 0x007B | 90. |
| 0x7C | 0x7C | | Vertical Line | 0x007C | 91. |
| 0x7D | 0x7D | } | Right Curly Bracket | 0x007D | 92. |
| 0x7E | 0x7E | ~ | Tilde | 0x007E | 93. |
| 0xA0 | 0xA0 | ␣ | No-Break Space | 0x00A0 | 94. |
| 0xA1 | 0xA1 | ¡ | Inverted Exclamation Mark | 0x00A1 | 95. |
| 0xA2 | 0xA2 | ¢ | Cent Sign | 0x00A2 | 96. |
| 0xA3 | 0xA3 | £ | Pound Sign | 0x00A3 | 97. |
| 0xA5 | 0xA5 | ¥ | Yen Sign | 0x00A5 | 98. |
| 0xA7 | 0xA7 | § | Section Sign | 0x00A7 | 99. |
| 0xD3 | 0xA9 | © | Copyright Sign | 0x00A9 | 100. |
| 0xE3 | 0xAA | ^a | Feminine Ordinal Indicator | 0x00AA | 101. |
| 0xFF | 0xAD | | Soft Hyphen ^{a)} | 0x00AD | 102. |
| 0xD2 | 0xAE | ® | Registered Sign | 0x00AE | 103. |
| 0xB0 | 0xB0 | ° | Degree Sign | 0x00B0 | 104. |
| 0xB7 | 0xB7 | · | Middle Dot | 0x00B7 | 105. |
| 0xEB | 0xBA | º | Masculine Ordinal Indicator | 0x00BA | 106. |
| 0xBC | 0xBC | | Vulgar Fraction One Quarter | 0x00BC | 107. |
| 0xBD | 0xBD | | Vulgar Fraction One Half | 0x00BD | 108. |
| 0xBE | 0xBE | | Vulgar Fraction Three Quarters | 0x00BE | 109. |
| 0xBF | 0xBF | ¿ | Inverted Question Mark | 0x00BF | 110. |
| 0xC1 0x41 | 0xC0 | À | Latin Capital Letter A With Grave | 0x00C0 | 111. |
| 0xC2 0x41 | 0xC1 | Á | Latin Capital Letter A With Acute | 0x00C1 | 112. |
| 0xC3 0x41 | 0xC2 | Â | Latin Capital Letter A With Circumflex | 0x00C2 | 113. |
| 0xC4 0x41 | 0xC3 | Ã | Latin Capital Letter A With Tilde | 0x00C3 | 114. |
| 0xC8 0x41 | 0xC4 | Ä | Latin Capital Letter A With Diaeresis | 0x00C4 | 115. |

| ISO/IEC 6937 | ISO/IEC 8859-9 | | Character name | UCS2 | |
|--------------|----------------|---|--|--------|------|
| 0xCA 0x41 | 0xC5 | Å | Latin Capital Letter A With Ring Above | 0x00C5 | 116. |
| 0xE1 | 0xC6 | Æ | Latin Capital Letter Ae | 0x00C6 | 117. |
| 0xCB 0x43 | 0xC7 | Ç | Latin Capital Letter C With Cedilla | 0x00C7 | 118. |
| 0xC1 0x45 | 0xC8 | È | Latin Capital Letter E With Grave | 0x00C8 | 119. |
| 0xC2 0x45 | 0xC9 | É | Latin Capital Letter E With Acute | 0x00C9 | 120. |
| 0xC3 0x45 | 0xCA | Ê | Latin Capital Letter E With Circumflex | 0x00CA | 121. |
| 0xC8 0x45 | 0xCB | Ë | Latin Capital Letter E With Diaeresis | 0x00CB | 122. |
| 0xC1 0x49 | 0xCC | Ì | Latin Capital Letter I With Grave | 0x00CC | 123. |
| 0xC2 0x49 | 0xCD | Í | Latin Capital Letter I With Acute | 0x00CD | 124. |
| 0xC3 0x49 | 0xCE | Î | Latin Capital Letter I With Circumflex | 0x00CE | 125. |
| 0xC8 0x49 | 0xCF | Ï | Latin Capital Letter I With Diaeresis | 0x00CF | 126. |
| 0xE2 | | | Latin Capital Letter Eth | 0x00D0 | 127. |
| 0xC4 0x4E | 0xD1 | Ñ | Latin Capital Letter N With Tilde | 0x00D1 | 128. |
| 0xC1 0x4F | 0xD2 | Ò | Latin Capital Letter O With Grave | 0x00D2 | 129. |
| 0xC2 0x4F | 0xD3 | Ó | Latin Capital Letter O With Acute | 0x00D3 | 130. |
| 0xC3 0x4F | 0xD4 | Ô | Latin Capital Letter O With Circumflex | 0x00D4 | 131. |
| 0xC4 0x4F | 0xD5 | Õ | Latin Capital Letter O With Tilde | 0x00D5 | 132. |
| 0xC8 0x4F | 0xD6 | Ö | Latin Capital Letter O With Diaeresis | 0x00D6 | 133. |
| 0xB4 | 0xD7 | | Multiplication Sign | 0x00D7 | 134. |
| 0xE9 | 0xD8 | Ø | Latin Capital Letter O With Stroke | 0x00D8 | 135. |
| 0xC1 0x55 | 0xD9 | Ù | Latin Capital Letter U With Grave | 0x00D9 | 136. |
| 0xC2 0x55 | 0xDA | Ú | Latin Capital Letter U With Acute | 0x00DA | 137. |
| 0xC3 0x55 | 0xDB | Û | Latin Capital Letter U With Circumflex | 0x00DB | 138. |
| 0xC8 0x55 | 0xDC | Ü | Latin Capital Letter U With Diaeresis | 0x00DC | 139. |
| 0xC2 0x59 | | | Latin Capital Letter Y With Acute | 0x00DD | 140. |
| 0xEC | | | Latin Capital Letter Thorn | 0x00DE | 141. |
| 0xFB | 0xDF | ß | Latin Small Letter Sharp S | 0x00DF | 142. |
| 0xC1 0x61 | 0xE0 | à | Latin Small Letter A With Grave | 0x00E0 | 143. |
| 0xC2 0x61 | 0xE1 | á | Latin Small Letter A With Acute | 0x00E1 | 144. |
| 0xC3 0x61 | 0xE2 | â | Latin Small Letter A With Circumflex | 0x00E2 | 145. |
| 0xC4 0x61 | 0xE3 | ã | Latin Small Letter A With Tilde | 0x00E3 | 146. |
| 0xC8 0x61 | 0xE4 | ä | Latin Small Letter A With Diaeresis | 0x00E4 | 147. |
| 0xCA 0x61 | 0xE5 | å | Latin Small Letter A With Ring Above | 0x00E5 | 148. |
| 0xF1 | 0xE6 | æ | Latin Small Letter Ae | 0x00E6 | 149. |
| 0xCB 0x63 | 0xE7 | ç | Latin Small Letter C With Cedilla | 0x00E7 | 150. |
| 0xC1 0x65 | 0xE8 | è | Latin Small Letter E With Grave | 0x00E8 | 151. |
| 0xC2 0x65 | 0xE9 | é | Latin Small Letter E With Acute | 0x00E9 | 152. |
| 0xC3 0x65 | 0xEA | ê | Latin Small Letter E With Circumflex | 0x00EA | 153. |
| 0xC8 0x65 | 0xEB | ë | Latin Small Letter E With Diaeresis | 0x00EB | 154. |
| 0xC1 0x69 | 0xEC | ì | Latin Small Letter I With Grave | 0x00EC | 155. |
| 0xC2 0x69 | 0xED | í | Latin Small Letter I With Acute | 0x00ED | 156. |
| 0xC3 0x69 | 0xEE | î | Latin Small Letter I With Circumflex | 0x00EE | 157. |
| 0xC8 0x69 | 0xEF | ï | Latin Small Letter I With Diaeresis | 0x00EF | 158. |

| ISO/IEC 6937 | ISO/IEC 8859-9 | | Character name | UCS2 | |
|--------------|----------------|---|--|--------|------|
| 0xF3 | | | Latin Small Letter Eth | 0x00F0 | 159. |
| 0xC4 0x6E | 0xF1 | ñ | Latin Small Letter N With Tilde | 0x00F1 | 160. |
| 0xC1 0x6F | 0xF2 | ò | Latin Small Letter O With Grave | 0x00F2 | 161. |
| 0xC2 0x6F | 0xF3 | ó | Latin Small Letter O With Acute | 0x00F3 | 162. |
| 0xC3 0x6F | 0xF4 | ô | Latin Small Letter O With Circumflex | 0x00F4 | 163. |
| 0xC4 0x6F | 0xF5 | õ | Latin Small Letter O With Tilde | 0x00F5 | 164. |
| 0xC8 0x6F | 0xF6 | ö | Latin Small Letter O With Diaeresis | 0x00F6 | 165. |
| 0xB8 | 0xF7 | ÷ | Division Sign | 0x00F7 | 166. |
| 0xF9 | 0xF8 | ø | Latin Small Letter O With Stroke | 0x00F8 | 167. |
| 0xC1 0x75 | 0xF9 | ù | Latin Small Letter U With Grave | 0x00F9 | 168. |
| 0xC2 0x75 | 0xFA | ú | Latin Small Letter U With Acute | 0x00FA | 169. |
| 0xC3 0x75 | 0xFB | û | Latin Small Letter U With Circumflex | 0x00FB | 170. |
| 0xC8 0x75 | 0xFC | ü | Latin Small Letter U With Diaeresis | 0x00FC | 171. |
| 0xC2 0x79 | | | Latin Small Letter Y With Acute | 0x00FD | 172. |
| 0xFC | | | Latin Small Letter Thorn | 0x00FE | 173. |
| 0xC8 0x79 | 0xFF | ÿ | Latin Small Letter Y With Diaeresis | 0x00FF | 174. |
| 0xC5 0x41 | | | Latin Capital Letter A With Macron | 0x0100 | 175. |
| 0xC5 0x61 | | | Latin Small Letter A With Macron | 0x0101 | 176. |
| 0xC6 0x41 | | | Latin Capital Letter A With Breve | 0x0102 | 177. |
| 0xC6 0x61 | | | Latin Small Letter A With Breve | 0x0103 | 178. |
| 0xCE 0x41 | | | Latin Capital Letter A With Ogonek | 0x0104 | 179. |
| 0xCE 0x61 | | | Latin Small Letter A With Ogonek | 0x0105 | 180. |
| 0xC2 0x43 | | | Latin Capital Letter C With Acute | 0x0106 | 181. |
| 0xC2 0x63 | | | Latin Small Letter C With Acute | 0x0107 | 182. |
| 0xC3 0x43 | | | Latin Capital Letter C With Circumflex | 0x0108 | 183. |
| 0xC3 0x63 | | | Latin Small Letter C With Circumflex | 0x0109 | 184. |
| 0xC7 0x43 | | | Latin Capital Letter C With Dot Above | 0x010A | 185. |
| 0xC7 0x63 | | | Latin Small Letter C With Dot Above | 0x010B | 186. |
| 0xCF 0x43 | | | Latin Capital Letter C With Caron | 0x010C | 187. |
| 0xCF 0x63 | | | Latin Small Letter C With Caron | 0x010D | 188. |
| 0xCF 0x44 | | | Latin Capital Letter D With Caron | 0x010E | 189. |
| 0xCF 0x64 | | | Latin Small Letter D With Caron | 0x010F | 190. |
| 0xE2 | | | Latin Capital Letter D With Stroke | 0x0110 | 191. |
| 0xF2 | | | Latin Small Letter D With Stroke | 0x0111 | 192. |
| 0xC5 0x45 | | | Latin Capital Letter E With Macron | 0x0112 | 193. |
| 0xC5 0x65 | | | Latin Small Letter E With Macron | 0x0113 | 194. |
| 0xC7 0x45 | | | Latin Capital Letter E With Dot Above | 0x0116 | 195. |
| 0xC7 0x65 | | | Latin Small Letter E With Dot Above | 0x0117 | 196. |
| 0xCE 0x45 | | | Latin Capital Letter E With Ogonek | 0x0118 | 197. |
| 0xCE 0x65 | | | Latin Small Letter E With Ogonek | 0x0119 | 198. |
| 0xCF 0x45 | | | Latin Capital Letter E With Caron | 0x011A | 199. |
| 0xCF 0x65 | | | Latin Small Letter E With Caron | 0x011B | 200. |
| 0xC3 0x47 | | | Latin Capital Letter G With Circumflex | 0x011C | 201. |

| ISO/IEC 6937 | ISO/IEC 8859-9 | | Character name | UCS2 | |
|--------------|----------------|---|--|--------|------|
| 0xC3 0x67 | | | Latin Small Letter G With Circumflex | 0x011D | 202. |
| 0xC6 0x47 | 0xD0 | | Latin Capital Letter G With Breve | 0x011E | 203. |
| 0xC6 0x67 | 0xF0 | | Latin Small Letter G With Breve | 0x011F | 204. |
| 0xC7 0x47 | | | Latin Capital Letter G With Dot Above | 0x0120 | 205. |
| 0xC7 0x67 | | | Latin Small Letter G With Dot Above | 0x0121 | 206. |
| 0xCB 0x47 | | | Latin Capital Letter G With Cedilla | 0x0122 | 207. |
| 0xCB 0x67 | | | Latin Small Letter G With Cedilla | 0x0123 | 208. |
| 0xC3 0x48 | | | Latin Capital Letter H With Circumflex | 0x0124 | 209. |
| 0xC3 0x68 | | | Latin Small Letter H With Circumflex | 0x0125 | 210. |
| 0xE4 | | | Latin Capital Letter H With Stroke | 0x0126 | 211. |
| 0xF4 | | | Latin Small Letter H With Stroke | 0x0127 | 212. |
| 0xC4 0x49 | | | Latin Capital Letter I With Tilde | 0x0128 | 213. |
| 0xC4 0x69 | | | Latin Small Letter I With Tilde | 0x0129 | 214. |
| 0xC5 0x49 | | | Latin Capital Letter I With Macron | 0x012A | 215. |
| 0xC5 0x69 | | | Latin Small Letter I With Macron | 0x012B | 216. |
| 0xCE 0x49 | | | Latin Capital Letter I With Ogonek | 0x012E | 217. |
| 0xCE 0x69 | | | Latin Small Letter I With Ogonek | 0x012F | 218. |
| 0xC7 0x49 | 0xDD | | Latin Capital Letter I With Dot Above | 0x0130 | 219. |
| 0xF5 | 0xFD | i | Latin Small Letter Dotless I | 0x0131 | 220. |
| 0xE6 | | | Latin Capital Ligature Ij | 0x0132 | 221. |
| 0xF6 | | | Latin Small Ligature Ij | 0x0133 | 222. |
| 0xC3 0x4A | | | Latin Capital Letter J With Circumflex | 0x0134 | 223. |
| 0xC3 0x6A | | | Latin Small Letter J With Circumflex | 0x0135 | 224. |
| 0xCB 0x4B | | | Latin Capital Letter K With Cedilla | 0x0136 | 225. |
| 0xCB 0x6B | | | Latin Small Letter K With Cedilla | 0x0137 | 226. |
| 0xF0 | | | Latin Small Letter Kra | 0x0138 | 227. |
| 0xC2 0x4C | | | Latin Capital Letter L With Acute | 0x0139 | 228. |
| 0xC2 0x6C | | | Latin Small Letter L With Acute | 0x013A | 229. |
| 0xCB 0x4C | | | Latin Capital Letter L With Cedilla | 0x013B | 230. |
| 0xCB 0x6C | | | Latin Small Letter L With Cedilla | 0x013C | 231. |
| 0xCF 0x4C | | | Latin Capital Letter L With Caron | 0x013D | 232. |
| 0xCF 0x6C | | | Latin Small Letter L With Caron | 0x013E | 233. |
| 0xE7 | | | Latin Capital Letter L With Middle Dot | 0x013F | 234. |
| 0xF7 | | | Latin Small Letter L With Middle Dot | 0x0140 | 235. |
| 0xE8 | | | Latin Capital Letter L With Stroke | 0x0141 | 236. |
| 0xF8 | | | Latin Small Letter L With Stroke | 0x0142 | 237. |
| 0xC2 0x4E | | | Latin Capital Letter N With Acute | 0x0143 | 238. |
| 0xC2 0x6E | | | Latin Small Letter N With Acute | 0x0144 | 239. |
| 0xCB 0x4E | | | Latin Capital Letter N With Cedilla | 0x0145 | 240. |
| 0xCB 0x6E | | | Latin Small Letter N With Cedilla | 0x0146 | 241. |
| 0xCF 0x4E | | | Latin Capital Letter N With Caron | 0x0147 | 242. |
| 0xCF 0x6E | | | Latin Small Letter N With Caron | 0x0148 | 243. |
| 0xEE | | | Latin Capital Letter Eng | 0x014A | 244. |

| ISO/IEC 6937 | ISO/IEC 8859-9 | | Character name | UCS2 | |
|--------------|----------------|---|--|--------|------|
| 0xFE | | | Latin Small Letter Eng | 0x014B | 245. |
| 0xC5 0x4F | | | Latin Capital Letter O With Macron | 0x014C | 246. |
| 0xC5 0x6F | | | Latin Small Letter O With Macron | 0x014D | 247. |
| 0xCD 0x4F | | | Latin Capital Letter O With Double Acute | 0x0150 | 248. |
| 0xCD 0x6F | | | Latin Small Letter O With Double Acute | 0x0151 | 249. |
| 0xEA | | Œ | Latin Capital Ligature Oe | 0x0152 | 250. |
| 0xFA | | œ | Latin Small Ligature Oe | 0x0153 | 251. |
| 0xC2 0x52 | | | Latin Capital Letter R With Acute | 0x0154 | 252. |
| 0xC2 0x72 | | | Latin Small Letter R With Acute | 0x0155 | 253. |
| 0xCB 0x52 | | | Latin Capital Letter R With Cedilla | 0x0156 | 254. |
| 0xCB 0x72 | | | Latin Small Letter R With Cedilla | 0x0157 | 255. |
| 0xCF 0x52 | | | Latin Capital Letter R With Caron | 0x0158 | 256. |
| 0xCF 0x72 | | | Latin Small Letter R With Caron | 0x0159 | 257. |
| 0xC2 0x53 | | | Latin Capital Letter S With Acute | 0x015A | 258. |
| 0xC2 0x73 | | | Latin Small Letter S With Acute | 0x015B | 259. |
| 0xC3 0x53 | | | Latin Capital Letter S With Circumflex | 0x015C | 260. |
| 0xC3 0x73 | | | Latin Small Letter S With Circumflex | 0x015D | 261. |
| 0xCB 0x53 | 0xDE | | Latin Capital Letter S With Cedilla | 0x015E | 262. |
| 0xCB 0x73 | 0xFE | | Latin Small Letter S With Cedilla | 0x015F | 263. |
| 0xCF 0x53 | | | Latin Capital Letter S With Caron | 0x0160 | 264. |
| 0xCF 0x73 | | | Latin Small Letter S With Caron | 0x0161 | 265. |
| 0xCB 0x54 | | | Latin Capital Letter T With Cedilla | 0x0162 | 266. |
| 0xCB 0x74 | | | Latin Small Letter T With Cedilla | 0x0163 | 267. |
| 0xCF 0x54 | | | Latin Capital Letter T With Caron | 0x0164 | 268. |
| 0xCF 0x74 | | | Latin Small Letter T With Caron | 0x0165 | 269. |
| 0xED | | | Latin Capital Letter T With Stroke | 0x0166 | 270. |
| 0xFD | | | Latin Small Letter T With Stroke | 0x0167 | 271. |
| 0xC4 0x55 | | | Latin Capital Letter U With Tilde | 0x0168 | 272. |
| 0xC4 0x75 | | | Latin Small Letter U With Tilde | 0x0169 | 273. |
| 0xC5 0x55 | | | Latin Capital Letter U With Macron | 0x016A | 274. |
| 0xC5 0x75 | | | Latin Small Letter U With Macron | 0x016B | 275. |
| 0xC6 0x55 | | | Latin Capital Letter U With Breve | 0x016C | 276. |
| 0xC6 0x75 | | | Latin Small Letter U With Breve | 0x016D | 277. |
| 0xCA 0x55 | | | Latin Capital Letter U With Ring Above | 0x016E | 278. |
| 0xCA 0x75 | | | Latin Small Letter U With Ring Above | 0x016F | 279. |
| 0xCD 0x55 | | | Latin Capital Letter U With Double Acute | 0x0170 | 280. |
| 0xCD 0x75 | | | Latin Small Letter U With Double Acute | 0x0171 | 281. |
| 0xCE 0x55 | | | Latin Capital Letter U With Ogonek | 0x0172 | 282. |
| 0xCE 0x75 | | | Latin Small Letter U With Ogonek | 0x0173 | 283. |
| 0xC3 0x57 | | | Latin Capital Letter W With Circumflex | 0x0174 | 284. |
| 0xC3 0x77 | | | Latin Small Letter W With Circumflex | 0x0175 | 285. |
| 0xC3 0x59 | | | Latin Capital Letter Y With Circumflex | 0x0176 | 286. |
| 0xC3 0x79 | | | Latin Small Letter Y With Circumflex | 0x0177 | 287. |

| ISO/IEC 6937 | ISO/IEC 8859-9 | | Character name | UCS2 | |
|--|----------------|---|---|------------------------|------|
| 0xC8 0x59 | | ÿ | Latin Capital Letter Y With Diaeresis | 0x0178 | 288. |
| 0xC2 0x5A | | | Latin Capital Letter Z With Acute | 0x0179 | 289. |
| 0xC2 0x7A | | | Latin Small Letter Z With Acute | 0x017A | 290. |
| 0xC7 0x5A | | | Latin Capital Letter Z With Dot Above | 0x017B | 291. |
| 0xC7 0x7A | | | Latin Small Letter Z With Dot Above | 0x017C | 292. |
| 0xCF 0x5A | | | Latin Capital Letter Z With Caron | 0x017D | 293. |
| 0xCF 0x7A | | | Latin Small Letter Z With Caron | 0x017E | 294. |
| 0xCF 0x41 | | | Latin Capital Letter A With Caron ^{b)} | 0x01CD | 295. |
| 0xCF 0x61 | | | Latin Small Letter A With Caron ^{b)} | 0x01CE | 296. |
| 0xC1 0x57 | | | Latin Capital Letter W With Grave ^{c)} | 0x1E80 | 297. |
| 0xC1 0x77 | | | Latin Small Letter W With Grave ^{c)} | 0x1E81 | 298. |
| 0xC2 0x57 | | | Latin Capital Letter W With Acute ^{c)} | 0x1E82 | 299. |
| 0xC2 0x77 | | | Latin Small Letter W With Acute ^{c)} | 0x1E83 | 300. |
| 0xC8 0x57 | | | Latin Capital Letter W With Diaeresis ^{c)} | 0x1E84 | 301. |
| 0xC8 0x77 | | | Latin Small Letter W With Diaeresis ^{c)} | 0x1E85 | 302. |
| 0xC1 0x59 | | | Latin Capital Letter Y With Grave ^{c)} | 0x1EF2 | 303. |
| 0xC1 0x79 | | | Latin Small Letter Y With Grave ^{c)} | 0x1EF3 | 304. |
| 0xA9 | | ‘ | Left Single Quotation Mark | 0x2018 | 305. |
| 0xB9 | | ’ | Right Single Quotation Mark | 0x2019 | 306. |
| 0xAA | | “ | Left Double Quotation Mark | 0x201C | 307. |
| 0xBA | | ” | Right Double Quotation Mark | 0x201D | 308. |
| 0xD4 | | ™ | Trade Mark Sign | 0x2122 | 309. |
| 0xAC | | | Leftwards Arrow | 0x2190 | 310. |
| 0xAD | | | Upwards Arrow | 0x2191 | 311. |
| 0xAE | | | Rightwards Arrow | 0x2192 | 312. |
| 0xAF | | | Downwards Arrow | 0x2193 | 313. |
| 0xD5 | | | Eighth Note | 0x266A or 0x266B | 314. |
| <p>a) As described in TR 101 211, the SHY character indicates a position where long words can be hyphenated. If when presented, there is no requirement to hyphenate the word this behaves as a non-printing, non-spacing character. If the word is hyphenated to break it across one or more lines then behaviour is as if the SHY character is replaced by a normal hyphen character (unicode 0x002D) followed by a carriage return.</p> <p>b) These characters are added to support Norwegian.</p> <p>c) These characters are added to support Welsh.</p> | | | | | |

Annex B (normative)

DVB-SI PDC descriptor

B.1 General

This annex describes a descriptor which has been agreed by DVB SI-DAT, but not yet published in EN 300 468 and TR 101 211. Since a definition of this descriptor is essential for the understanding of the text on recording (see 9.6), the definition of the descriptor is reproduced here. The conditions for inclusion of this descriptor are addressed under 9.2.8.

NOTE This description is based on documents SI_DAT 460, SI_DAT 480 and SI_DAT 441r7.

B.2 PDC descriptor

This descriptor, for use in the EIT, defines a programme identification label (PIL) as defined in ETS 300 231 for an event.

Table B.1 – Syntax of the PDC descriptor

| Syntax | No. of bits | Type |
|--------------------------------|-------------|--------|
| PDC_descriptor() { | | |
| descriptor_tag | 8 | uimsbf |
| descriptor_length | 8 | uimsbf |
| reserved_future_use | 4 | bslbf |
| programme_identification_label | 20 | bslbf |
| } | | |

B.2.1 descriptor_tag

This 8 bit field with value 0x69 identifies this descriptor.

B.2.2 descriptor_length

This 8 bit integer identifies the number of bytes following this length field.

B.2.3 programme_identification_label

This 20-bit field gives the programme identification label.

The structure of the programme identification label (PIL) is as follows:

| Programme identification label | | | | | | | | | | | | | | | | | | | | | | | | | | | | | |
|--------------------------------|---|---|---|---|-------|---|---|---|----|------|----|----|----|----|--------|----|----|----|----|---|--|--|--|--|---|--|--|--|--|
| 1 | 2 | 3 | 4 | 5 | 6 | 7 | 8 | 9 | 10 | 11 | 12 | 13 | 14 | 15 | 16 | 17 | 18 | 19 | 20 | | | | | | | | | | |
| M | | | | | L | | | | | M | | | | | L | | | | | M | | | | | L | | | | |
| Day | | | | | Month | | | | | Hour | | | | | Minute | | | | | | | | | | | | | | |

The PIL contains the date and the time of the first published start time of a certain event.

Within analogue systems, the PIL is either broadcast in the teletext format (PDC) or as a part of the VPS label in dataline 16. The values for the day, month, hour and minute are binary coded.

No change is made to the PIL once it has been made publicly available, provided the transmission time remains within the validity time window (as defined in ETS 300 231).

Annex C (normative)

Subtitling

This annex is reproduced from the DTG “D- Book” version 3 with permission.

C.1 General

This clause defines the graphics standards to be used for providing subtitles that shall be used in all UK UHF terrestrial television broadcasts.

This standard is based on EN 300 743 V1.2.1 (2002) but with a number of clarifications, corrigenda and extensions detailed here.

C.2 Essential requirements

Subtitles in DTG television broadcasts shall be encoded as bitmaps according to EN 300 743 V1.2.1 (2002). The RNIB font Tiresias has been designed for this purpose.

All receivers shall include provision to decode and display subtitles conforming to EN 300 743 V1.2.1 (2002) as clarified in Clause C.4.

C.3 Clarifications to EN 300 743 V1.2.1 (2002)

C.3.1 Sequence of segments

Figure C.1 illustrates the allowed sequence of segments in a subtitle stream. Each PCS indicates the start of a display set. The set of segments that follows will depend on the operation being performed in that display set.

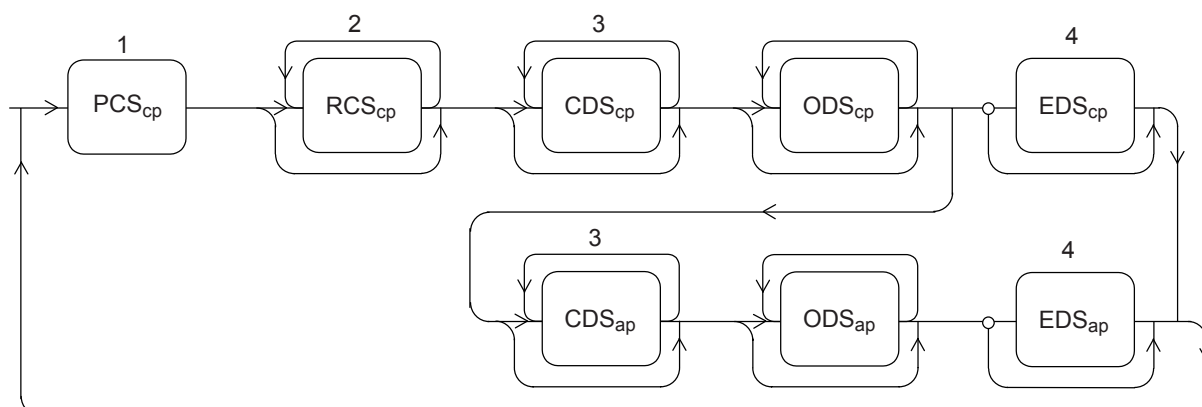

IEC 2266/01

PCS = Page Composition Segment
 RCS = Region Composition Segment
 CDS = Clut Data Segment
 ODS = Object Data Segment
 EDS = End of Display set Segment

cp = Composition Page
 ap = Ancillary Page

| Note | page_state | | |
|--------|--|---|-------------|
| | Normal case | Acquisition point | Mode change |
| NOTE 1 | All display sets start with a PCS | | |
| NOTE 2 | Optional unless the region is to be operated upon. | All regions must be present to reserve memory for them during the remainder of the epoch. | |
| NOTE 3 | CDSs are only required if non-default colours are to be defined. | | |
| | | CDSs are not required at the beginning of an epoch to reserve memory, references to CLUT families from regions are sufficient to declare the memory required. | |
| NOTE 4 | Each display set has at most one EDS. This is a recommended but not mandatory segment. Receivers can take advantage of it but should not rely on it. The EDS is either the last segment of the ancillary page or the last segment of the composition page, depending on the presence or absence of ancillary data in the display set. | | |

Figure C.1 – High level bitstream organisation

C.3.2 Indication of updates

The version number fields in the PCS, RCS and CDS ¹¹⁾ segments are significant to the decoder.

Subtitle encoders *increment* the version number (modulo 16) to indicate changes. Decoders should respond to a *change* in the version number.

C.3.2.1 Dependence on version number changes

When decoding a display set *it is sufficient* for a decoder to look for changes in `page_version_number` and `region_version_number`. If a change in `region_version_number` is observed for a region, the decoder shall also look for a change in the `CLUT_version_number` of the CLUT associated with that region.

¹¹⁾ It is possible that the version number of object data segments may be significant in the common interface low-level MMI use of DVB subtitles, this needs further consideration.

C.3.2.2 page_version_number

Changes to the `page_version_number` indicate that the data in the PCS has changed. For example, one or more regions might be repositioned or the set of visible regions might be changed.

A change in the visual appearance of regions does not require the `page_version_number` to increment. So, decoding an object into a region, or modifying a region's CLUT does not require the `page_version_number` to increment.

C.3.2.3 region_version_number

Changes to the `region_version_number` indicate either that the data in the RCS has changed or that a graphics operation is to be performed on the region as a result of

- the region fill flag being set;
- the contents of the region's CLUT being modified;
- one or more objects being in the region's object list.

C.3.2.4 CLUT_version_number

Changes to the `CLUT_version_number` indicate that one or more locations in the CLUT family held by the receiver are to be modified.

NOTE So, at (or after) an acquisition point when the encoder delivers the initial state of a CLUT family, the `CLUT_version_number` may remain constant if that state is consistent with the state held by receivers that have previously acquired the service.

Decoder behaviour when a CLUT is modified is only defined if ALL regions dependent on that CLUT are present with changed version numbers.

C.3.3 Colour translation during object decoding

C.3.3.1 Requested and allocated region depths

A region's `region_depth` specifies the "requested" pixel depth for that region. A region's `region_level_of_compatibility` (RLOC) indicates the minimum pixel depth that shall be "allocated" to the region.

C.3.3.1.1 Background

EN 300 743 V1.2.1 (2002) was developed at a time when it was not practical for all receivers to deliver the "requested" pixel depth because of either memory limitations or hardware CLUT limitations. This precipitated the concept of an "allocated" pixel depth which might be less than the "requested" depth.

The UK receiver profile requires the full logical decoder memory model to be implemented by all compatible receivers. So, the "allocated" region depth shall in all cases be the "requested" depth. The descriptions provided here are provided for the benefit of other application domains that may wish to define subtitle interoperability on lower profile receivers.

C.3.3.1.2 Determining if a region can be displayed on reduced profile hardware

If a decoder cannot allocate a region depth compatible with the region's RLOC, then the region shall be ignored.

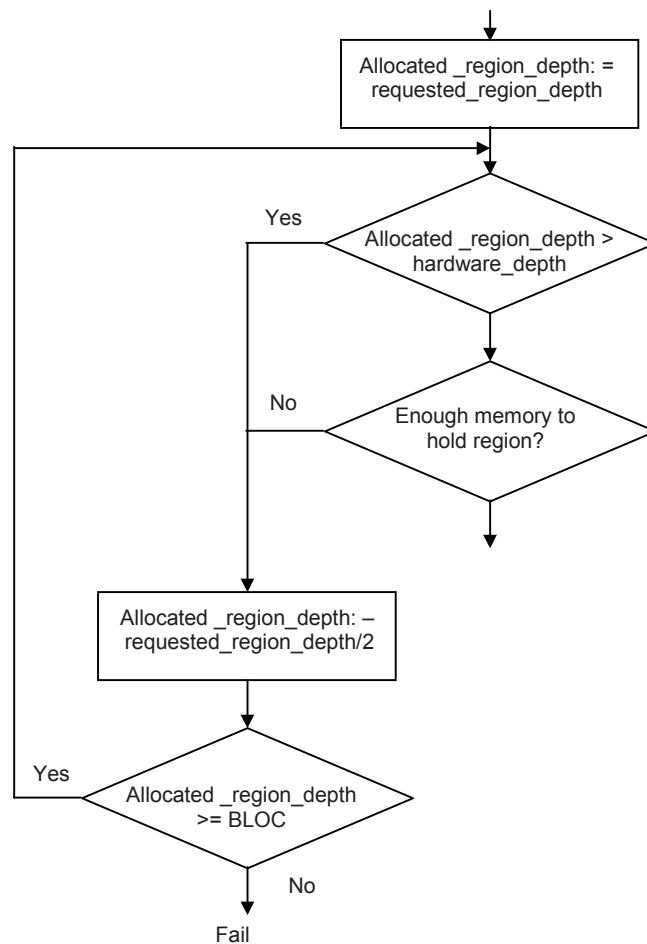

IEC 2267/01

Figure C.2 – Region depth selection

C.3.3.2 Object decoding

C.3.3.2.1 Code string expansion

Bitmap objects are decoded with reference to the “requested” **region_depth** of the region that receives them.

The compressed data yields 2, 4 and 8 bit values which are mapped via map-tables into colour indexes appropriate for the receiving region. For example, an object destined for a region with a “requested” depth of 8 bits per pixel might contain 2-bit/pixel and 4-bit/pixel code strings. The 2_to_8 and 4_to_8 map tables (either the default tables or those embedded in the object) yield 8 bit values.

If the same object is also instantiated in a region with a different depth, such as 4 bits, then the same 2-bit/pixel and 4-bit/pixel code strings are mapped through the 2_to_4 and the “unity” 4 to 4 mapping tables to yield 4 bit values.

In effect, the object is decoded twice (once for each instance). This burden is already understood in the EN 300 743 V1.2.1 (2002) decoder model. Manufacturers may be able to make more efficient implementations, but this is not relied upon by the encoder.

This mapping from code strings, through the map tables, to pixels in destination regions with the “requested” pixel depth is illustrated in Figure C.3.

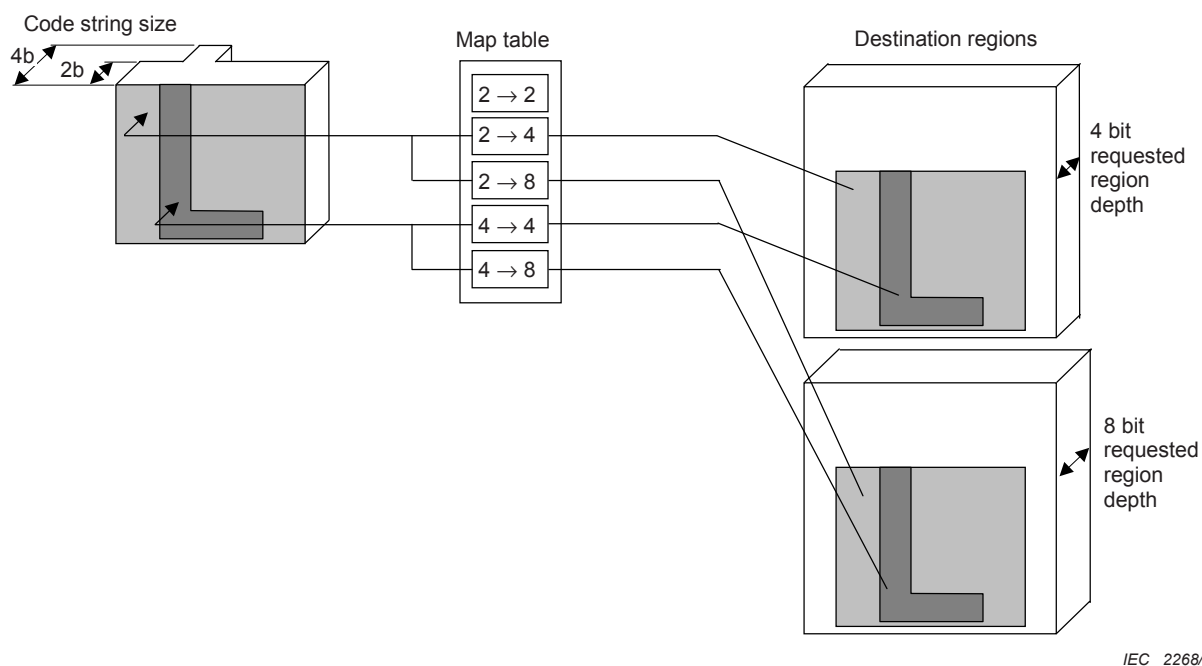
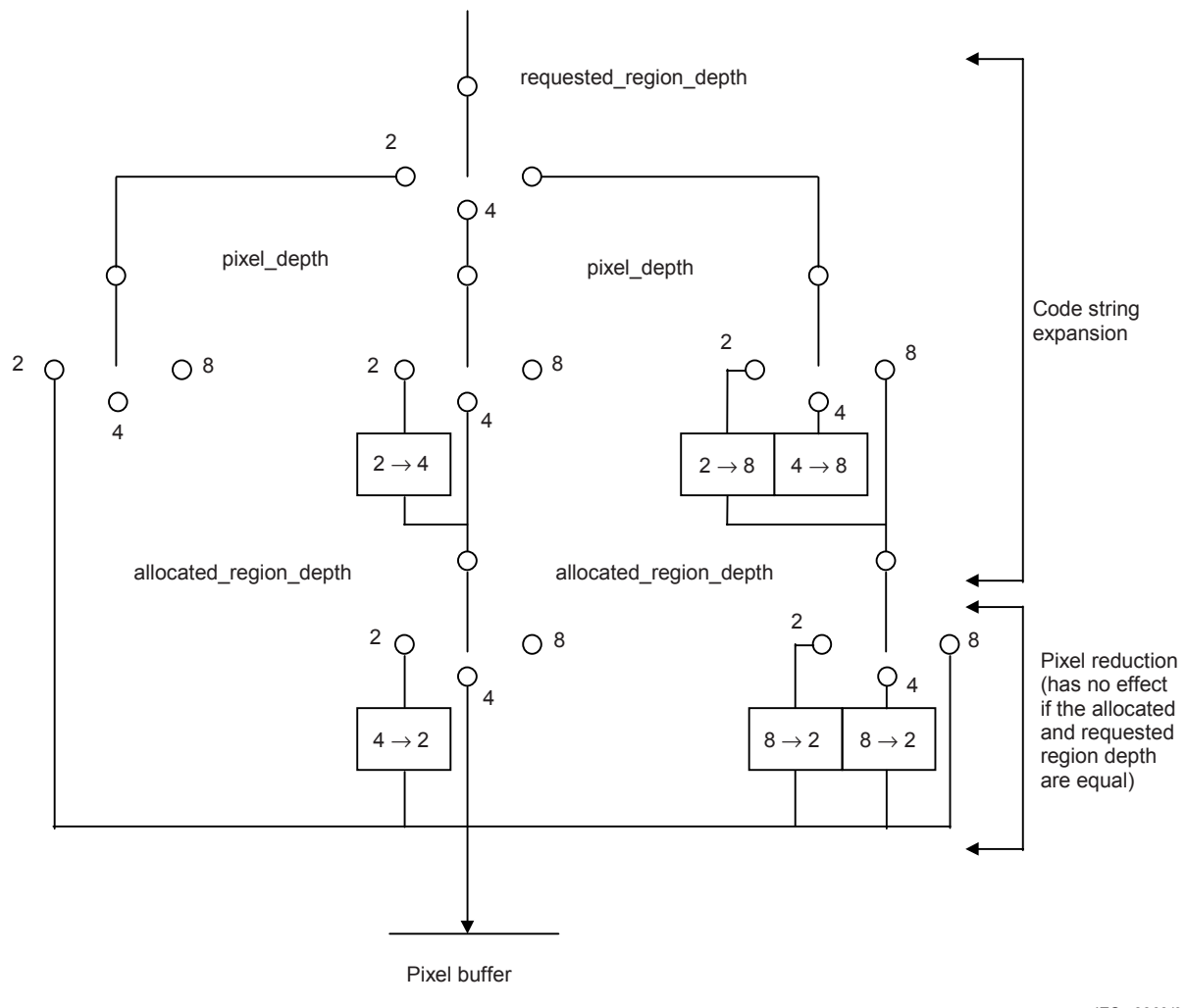

Figure C.3 – Mapping code strings to pixels in “requested” depth region

NOTE See C.4.3.1.4.

C.3.3.2.2 When “allocated” depth is less than “requested”

Figure C.4 shows the complete set of code string expansions and also shows the subsequent pixel reduction that applies if the “allocated” depth of the region is less than the “requested” depth. Figure C.4 clarifies Figure 10.1 in section 9 of EN 300 743 V1.2.1 (2002).



IEC 2269/01

Figure C.4 – Mapping code strings to pixels

C.3.3.2.3 Clarifications

The following are clarifications where there is some ambiguity in EN 300 743 V1.2.1 (2002):

- Coded objects shall not have code strings with more bits per pixel than the “requested” pixel depth of any region in which the object is instanced.
- At the start of decoding an object data segment, the map tables used whilst decoding are reset to the default values given in Tables 11 to 13 of EN 300 743 V1.2.1 (2002). New map table definitions delivered by “n_to_n-bit map table data” pixel data sub blocks have affect until the earlier of the end of the object data segment or a further “n_to_n-bit map table data” pixel data sub block.
- The order of decoding is strictly the order in which the data is delivered by the object data segment.
- The top and bottom field data blocks in an object are relative to the top of the object (i.e. top field data block delivers pixels on the same scan line as the object_vertical_position).

Whether the top field data block corresponds to pixels in the upper field of an interlaced display will depend on the position of the object within the region and the position of the region. The bitmap data is split into 2 fields as it is more convenient for some OSD implementations.

C.3.4 Page time out

C.3.4.1 When page time out matures

The behaviour of the receiver when a page time out matures is as if a PCS_{normal_case} with an empty region list was used to update the display. In other words, all regions are removed from the display, but in other respects the state of the decoder remains intact.

When a receiver subsequently receives a PCS with a non-empty region list, the display will be updated in the normal way. If the time-out is known to the decoder, then it should comprehend the display update burden to re-display the regions cleared by the page time-out. If the time-out resulted from an error (as broadcast or in transmission), the receiver is responsible for recovering as best it can from the transient display update overload that may happen.

C.3.4.1.1 Time out is zero

EN 300 743 V1.2.1 (2002) defined `page_time_out` as:

“The period, expressed in seconds, after which the page is no longer valid”.

Accordingly, the value 0 means an immediate time out (i.e. within 0 s to 5 s after the PTS time for the display set).

C.3.5 Other clarifications

C.3.5.1 Region instances in PCS

Each region shall be instantiated at most once in a PCS.

C.3.5.2 Temporal scope of object references

No object caching is assumed in broadcast subtitle streams. Therefore, the scope of an `object_id` in an RCS is constrained to objects within the display set carrying the RCS¹²⁾. Also, the scope of an `object_id` is the composition and the ancillary pages for the display set. Therefore, an `object_id` used in one page cannot also be used in the other.

C.3.5.3 Repetition of segments in a display set

Decoder behaviour is not defined if segments of the same type and ID value are repeated within a single display set. For example, if two ODS with the same `object_id` are found in a display set, it is not defined if the decoder decodes the first, the second or both objects.

C.3.5.4 Segments are not fragmented between PES packets

Each PES packet carries an integer number of complete subtitle segments.

NOTE Encoders may benefit from fragmenting large bitmap objects so that they are represented by more than one ODS. See C.8.1

C.4 Revised decoder model

C.4.1 Background

The subtitle decoder model in EN 300 743 V1.2.1 (2002) was developed in the context of systems where the subtitle decoder was the only user of a region based, indexed colour, graphics system. In the UK environment, the subtitle decoder is no longer guaranteed sole access to the display (for example MHEG-5 applications may also concurrently be present) and the use of region based, indexed colour graphics hardware can no longer be assumed.

¹²⁾ Object caching applies in the common interface low-level MMI use of DVB subtitles, this needs further consideration.

The decoder model applied here offers comparable system functionality to that in EN 300 743 V1.2.1 (2002), but additionally constrains the encoding process to ensure interoperability in the UK DTT context.

C.4.2 Decoder model

This is a conceptual model used to define these terms precisely and to model the decoding process. The model decoder is defined only for this purpose. Neither the architecture of the model decoder, nor the timing described precludes uninterrupted, synchronized play-back of streams from a variety of decoders with different architectures or timing schedules.

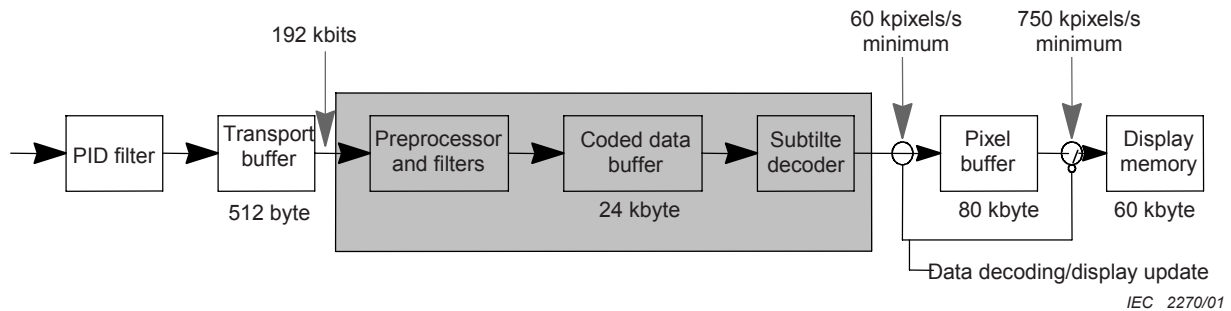

Figure C.5 – Subtitle reference decoder model

C.4.2.1 Transport buffer

As defined in EN 300 743 V1.2.1 (2002).

This 512 byte buffer is analogous to the buffers TB_n defined in ISO/IEC 13818-1. It fills at the transport stream rate and, if it contains data, empties at a rate (R_{X_n}) of 192 kbit/s.

C.4.2.2 Preprocessor and filters

As defined in EN 300 743 V1.2.1 (2002).

This selects appropriate PES packets and then subtitling segments on the basis of their `page_id` values.

C.4.2.3 Coded data buffer model

As in EN 300 743 V1.2.1 (2002) the coded data buffer is a 24 000 byte buffer. However, buffer fullness is modelled as the coded data being removed instantaneously at the time defined by the PTS for the display set ¹³⁾.

C.4.2.4 Pixel buffer

In the model decoder, the output of the subtitle decoder is considered to be written to an 80 000 byte off-screen “pixel buffer” as data is decoded. The decoder is then considered to update the “display memory” starting at the time defined by the PTS for the display set.

C.4.2.5 Display memory

Compatible with EN 300 743 V1.2.1 (2002), 60 000 bytes of display memory are available for visible pixels. As broadcasts are only allowed to use regions with 4 or 8 bits per pixel, the maximum number of displayed pixels is 120 000.

¹³⁾ In many practical implementations, decoding will start earlier than the PTS time but not “instantaneously” (but not slower than the 60 000 pixel per second minimum). In this case, the actual decoder buffer fullness will be less than predicted by this model.

C.4.2.6 Timing model

Two consecutive phases of processing are recognised:

- data decoding (from coded data buffer to pixel buffer), and
- display updating (from pixel buffer to display memory).

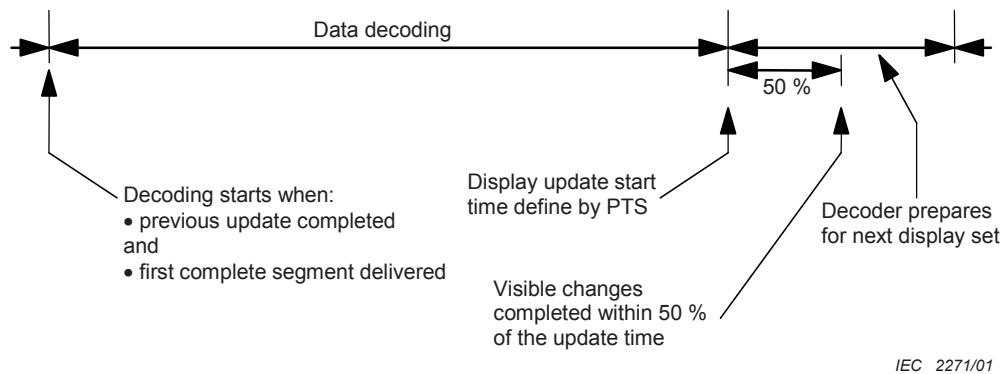

Figure C.6 – The two modelled decoding phases

The decoding process can start when the display updating process of the previous display set has completed and the first segment has been completely delivered to the decoder. The display update process starts at the time defined by the PTS of the display set.

C.4.2.6.1 Data decoding

The data decoding phase starts when the preceding display update phase is complete.

C.4.2.6.2 Epoch set-up

If the PCS has `page_state = 'mode change'` or `'acquisition point'` then there is a [200 ms] delay after complete reception of the PCS and the RCSs that define the memory use before any further segments are processed. During this time and segments delivered accumulate in the coded data buffer.

NOTE This allows for the memory management tasks required by a decoder acquiring the stream at this point.

The decoding of PCSs with the `page_state 'normal case'` and all segment types other than ODSs are assumed to be instantaneous.

C.4.2.6.3 Bitmap decoding

For each ODS, the model decoder decodes data at a rate of at least 60 000 pixels per second independent of the pixel depth of the region. Decoding starts when previous decoding tasks have been completed and the segment has been completely delivered to the decoder (see C.8.1).

C.4.2.6.4 Race avoidance

In addition to the above, condition the last ODS of a display set is allowed at least 25 ms to decode.

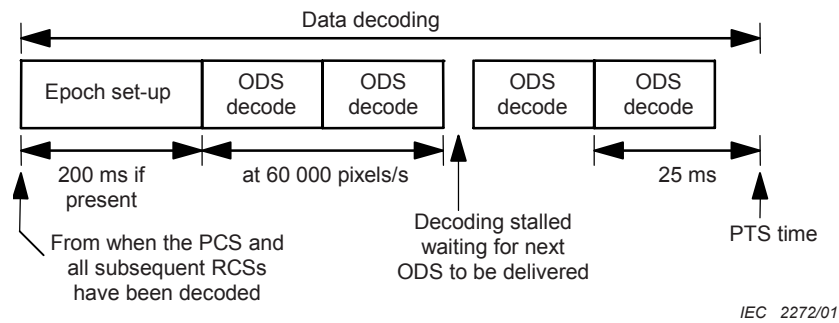

Figure C.7 – Detail of data decoding phase

C.4.2.6.5 Display update model

The display update process starts at the time indicated by the PTS of the display set. Except in the first display set of an epoch, no modifications are made to the display before the time indicated by the PTS.

The duration of the display update phase is based on an update rate of 375 000 pixels per second. However, modifications to the display shall be completed within 50 % of the time available.

NOTE This requirement requires an effective “display paint” rate of 750 000 pixels per second. This enables a 60 000 pixel subtitle to be transferred to the display in 80 ms. The balance of the time after display modification has been completed allows other operations that do not modify the display.

C.4.2.6.6 Start of epoch

The display update for the first display set of an epoch starts, as normal, at the PTS time for the display set, however, to allow the decoder to construct a new memory configuration, the display may be cleared for an implementation dependent time before this and remain clear until the PTS time. In the limiting case, the display may be cleared as soon as the **PCS_{mode change}** is decoded; in which case, the preceding display set may be only displayed for a very short time.

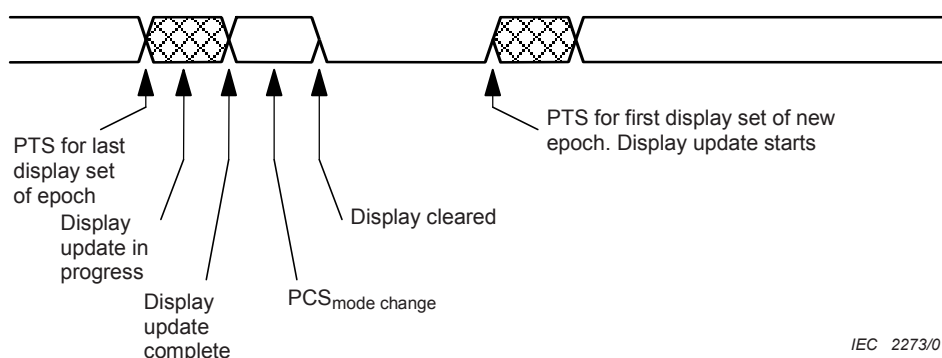

Figure C.8 – Disruption to display at start of new epoch

C.4.2.6.7 Updating within already visible regions

Where an object is decoded into regions that are already on-screen and are not being repositioned (i.e. the position of the region is the same in the page composition segment of the display set that is currently being decoded as in the previous display set), the display update burden is the number of pixels in the smallest rectangle that will enclose the object for each instance of that object. The region depth is not considered.

Here, objects are considered to be decoded into an off-screen copy of the “live” region and then copied to the “live” region during the update process.

C.4.2.6.8 Updating within off-screen regions

If objects are decoded into an off-screen region (i.e. a region that is not currently displayed) there is no display update burden unless the region becomes visible in this display set. In this case, the display update burden is that for the entire region (as described below) and the display update for objects newly decoded into the region is not considered.

C.4.2.6.9 Repositioning regions

Similarly, if a currently visible region is repositioned within the page, the display update burden is that for the entire region and the burden for newly decoded objects is not considered.

C.4.2.6.10 Updating pages and regions

All operations that modify the display memory are comprehended in the display update budget. Table C.1 defines the “weighting” for each pixel affected. For example, if a page composition segment provides a new definition for the position of a region, then the impact on the display update budget is twice the number of pixels in that region.

Table C.1 – Additional display update budget for page/region operations

| Operation | Weighting per pixel |
|--|---------------------|
| page_state = ‘mode change’ ^a | 1 |
| Removing a region from the page composition segment | 1 |
| Adding a region to the page composition segment | 1 |
| Moving a region within a page | 2 |
| Redefining any of the values within the CLUT associated with a region | 1 |
| ^a In other words, all previously existing regions in the display memory are re-drawn as transparent before their definition is deleted. | |
| ^b This affects all the pixels in any region using a redefined CLUT. | |

C.4.3 Encoding constraints

All broadcasts shall be encoded as specified in EN 300 743 V1.2.1 (2002) but addressing the modified decoder model (described above) and observing the following constraints.

C.4.3.1 Affecting memory requirements

This standard replaces the EN 300 743 V1.2.1 (2002) “composition buffer” with constraints on the number of regions, CLUT families and lists of objects that a decoder is required to handle. The size of this memory will be implementation dependent. This memory is in addition to the memory illustrated in Figure C.5.

NOTE EN 300 743 V1.2.1 (2002) specifies a 4 kbyte “composition buffer”. This was intended to comprehend the memory required to store static data structures describing the set of regions and their CLUTs used through an epoch and the transient data structures required to hold the list of objects used while decoding a display set.

C.4.3.1.1 Number of regions

The maximum number of regions defined in any epoch shall be 8.

Implicitly, this limits the number of CLUT families that can be defined to 8.

C.4.3.1.2 Number of objects

The maximum number of instances of objects in a single display set shall be 128.

C.4.3.1.3 Number of colours

Only 64 different colours with indices 0 to 63 may be used in any display.

To enable a receiver to determine the number of colours in use, the following restrictions apply:

- where a display contains one or more regions with 8 bit depth, then only a single CLUT family (i.e. a single CLUT ID) shall be referenced by all of the regions concurrently displayed;
- where a display contains only regions with 4 bit region depth, then up to 4 different CLUT families (i.e. ≤ 4 different CLUT IDs) may be referenced by all of the regions concurrently displayed.

C.4.3.1.4 Pixel depths

Regions shall not have a region_depth of 2 bits per pixel.

C.4.3.2 Affecting graphics system complexity**C.4.3.2.1 Levels of transparency**

Broadcasts should not rely on receivers implementing colour resolution greater than the non-full range mode.

Broadcasts should not rely on receivers implementing more than one intermediate (i.e. not 0 % or 100 %) level of transparency per screen.

See C.6.2.

C.4.3.2.2 Region line exclusivity

Each region monopolizes the scan lines of which it occupies any part; no two regions can be presented horizontally next to each other.

C.4.3.2.3 Region width and position

The width of each region (region_width) shall be an even number of pixels. The horizontal position (region_horizontal_address) of each region shall be an even number of pixels.

C.4.3.3 Stuffing

In circumstances for which it is deemed necessary or desirable to add stuffing to a component stream (e.g. so as to maintain a minimum bit-rate for network management reasons) two mechanisms are recognised:

- transport stream stuffing including adaptation-only TS packets in the relevant elementary stream;
- PES stream stuffing including PES packets with a stream_id set to padding_stream (value 0xBE) in the relevant elementary stream.

The transport stream stuffing mechanism is preferred (as in many receiver implementations, it presents a lower CPU burden). The PES stream stuffing mechanism although deprecated is allowed and shall be treated correctly by receivers.

The receiver behaviour in either case is the same. With reference to the “Decoder model” in C.4.2, stuffing data of whatever kind is deleted from the data stream before the data stream leaves the “Preprocessor and filters” section.

C.4.3.4 Multiple languages

EN 300 743 v1.2.1 (2002) supports the use of multiple subtitle services (e.g. multiple languages) by using different **page_ids** within a single subtitle stream which is itself encapsulated within a single PID. This allows for some sharing of data between subtitling services. However, it is often more convenient to convey multiple subtitle services in separate subtitle streams each conveyed in its own PID. Amongst other benefits this makes extraction of a particular subtitling service considerably easier in the decoder.

With appropriate signalling in the PSI and SI, both approaches are valid and, whilst compliant decoders must be able to accommodate both approaches, the coding of multiple languages using separate PIDs is strongly preferred.

C.4.3.5 Others

C.4.3.5.1 Successive display sets

The value of PTS for successive display sets shall be at least 120 ms apart.

C.5 UK specific features

C.5.1 Limitations and approximation of transparency

The coding provided by EN 300 743 v1.2.1 (2002) allows multiple intermediate levels of transparency per region.

C.5.1.1 Receiver requirement

Receivers are required to implement at least one intermediate level of transparency (in addition to opaque and complete transparency) per screen. Implementation of additional levels of transparency is optional.

C.5.1.2 Approximations

Where receiver hardware has limited ability to implement the number or values of semi-transparent colours encoded, the following approximations shall be applied:

- where receiver hardware implements fewer values of semi-transparency than are required by a CLUT family, then the receiver shall combine two or more consecutive semi-transparent values into a single implemented transparency. When reducing the set of levels of semi-transparency, lower transparency shall replace higher transparency;
For example, if a receiver implements a single value of transparency per region and CLUT family includes the transparency levels 10 %, 20 %, 30 % and 40 % then all semi-transparent levels shall be implemented as 10 %. Similarly, if the receiver can implement 2 levels of semi-transparency, then the recommended mapping is 40 %->30 %, 30 %->30 %, 20 %->10 %, 10 %->10 %.
- where the receiver cannot implement the encoded value of semi-transparency, it shall replace it with the nearest value of semi-transparency it can implement.

Semi-transparency shall not be approximated as either 0 % or 100 % transparency. For example, if a receiver can implement 33 % and 66 % transparency and a CLUT family uses 15 %, then 33 % shall be used rather than 0 %. A further example, if a CLUT family uses the following levels of transparency 25 %, 50 % and 75 %; and a receiver only allows a single intermediate level of transparency which could be 33 % or 66 %, then 33 % shall be used in all cases.

C.6 OSD conflicts

C.6.1 Spatial

Spatial conflicts between subtitles and graphics generated by other processes (for example MHEG-5 or user interface) shall be resolved by receivers in an implementation dependent way. Broadcasters requiring deterministic behaviour should avoid possible conflicts.

Conflicts between MHEG-5 and subtitles may occur if the bounding box of any MHEG-5 visible (except those of RTGraphics, video and bitmaps encoded as MPEG I frames) shares the same scan line with any region in the subtitles.

C.6.2 Transparent colours

The transparency of the semi-transparent colours available to MHEG-5 may be affected if the subtitle stream uses a level of transparency different from the default defined for MHEG-5.

C.7 System capabilities

Table C.2 characterises the behaviour of the above EN 300 743 v1.2.1 (2002) based subtitling system for certain “typical” forms of subtitle. The 3 columns on the left describe the way in which new text is delivered (for example infrequent blocks of text or frequent individual words). The right-hand columns illustrate the decode and display times for these subtitles.

Table C.2 – Example subtitle system performance

| Unit of added subtitle text | Area | Repetition rate | Decode time | Display update time |
|---|----------|-----------------|-------------|---------------------|
| Three rows of text | 64 kpels | One every 5 s | 1 000 ms | 80 ms |
| One row of text | 21 kpels | One every 1 s | 330 ms | <50 ms |
| Single word (average 5 characters) | 4 kpels | 5 per s | 75 ms | <40 ms |
| a) At 60 000 pixels per second. b) Starting at the nominal time defined by the PTS, this is the time until all display modification has been completed. This point is half way through the overall display update. See figure C.6. | | | | |

C.8 Encoding guidelines (informative)

C.8.1 Fragmentation to improve decoding

Encoders should not assume that decoders can start decoding a segment any sooner than when the last byte of that segment has been delivered to the decoder. If a large bitmap is transmitted this may result in significant delay before the decoder can “start work”. Encoders, by dividing large bitmaps into a number of small bitmap fragments that are then encoded as separate Object Data Segments, can overlap segment delivery with segment decode and thus allow segment decode to start earlier.

C.8.2 Definition of CLUTS at acquisition points

When CLUTs are introduced, they are initialised to hold the default CLUT described in section 10 of EN 300 743 v1.2.1 (2002). The CDS may redefine some or all of the locations in a CLUT. Display sets that are also acquisition points must contain one or more CDSs to reserve the memory for the CLUTs to be used by the regions in the epoch.

It is the encoder's responsibility to provide colour definitions in CDSs at (or shortly after) an acquisition point to ensure that decoders acquiring the stream at the current acquisition point have colour definitions consistent with those in decoders that acquired the service at an earlier acquisition point.

C.8.3 Efficient use of non_modifying_colour_flag

Decoder performance is likely to be affected if an object's non_modifying_colour_flag is set even if the object does not use any non-modifying colours. It is recommended that encoders should not set this flag for an object unless a non-modifying colour is used in the object.

C.8.4 PSI/SI signalling

Subtitling streams are signalled in the ISO/IEC 13818-1 Programme Map Table (PMT) using stream type 0x06 indicating PES packet private data.

The subtitling descriptor defined in section 6 of the DVB SI specification ETS 300 468 enables different subtitling streams to be distinguished by their ISO-639_language_code, subtitling_type, composition_page_id and ancillary_page_id. Note that if no ancillary page is transmitted the values of ancillary_page_id and composition_page_id in the subtitling descriptor should be the same.

C.9 Decoding guidelines

C.9.1 Subtitle timing

EN 300 743 v1.2.1 (2002) notes that there may be times when, due for example to slightly late arrival of a complete display set or to slow rendering in the decoder, the correct time to present a subtitle (i.e. when PTS = local system clock derived from the PCR) has passed. Late arrival can also result from injudicious throttling of the bit-rate assigned to a subtitling stream at some point in the distribution network.

Given the nature of subtitles, it is almost always better to display such a late subtitle than to discard it.

C.9.2 CLUT interpretation

EN 300 743 v1.2.1 (2002) section 7.2.3 includes notes relating to interpreting CLUT values into digital luminance and colour difference signals which accord with ITU-R Recommendations ITU-R BT.601-5 and ITU-R BT.656-4. They are summarised here:

Whilst EN 300 743 v1.2.1 (2002) uses a **Y_value** of zero in any CLUT entry to signal complete transparency, implementers should note that Y=0 is disallowed in ITU-R BT.601-3. This condition should be recognised and mapped to a legal value (e.g. Y=16d) before conversion to RGB values in the decoder.

Note also that, whilst EN 300 743 v1.2.1 (2002) defines CLUT entries in terms of Y, Cr, Cb and T values, the standard interface definition of digital television (ITU-R BT.656-4) presents co-sited sample values in the order Cb,Y,Cr. Failure to correctly interpret the rendered bitmap image in terms of ITU-R BT.656-4 may result in incorrect colours and chrominance mistiming.

C.10 Decoder treatment of errors

This is a non-exhaustive list of known errors. It identifies issues that are illegal encodings.

If these conditions reach the receiver, its behaviour is not prescribed. However, there is likely to be a range of responses depending on the specific error, the context, etc. It is an

implementation issue to develop error management techniques that ensure robustness without unnecessarily disturbing the display.

C.10.1 Segment order

Possible errors relating to segment order:

- Consecutive PTSs differ but by less than 120 ms.
- No PTS change preceding a PCS.
- PTS change preceding RCS, CDS or ODS.
- More than one PCS.
- ODS or CDS precedes RCS.
- Segment type is not one of 0x10-0x13, 0x080 or 0xFF.
- Segment is not aligned with PES packets because the PES payload does not start with sync byte.
- Segment is not aligned with PES packets because the segment extends beyond the length of the PES packet.

C.10.2 PCS

Possible errors relating to PCS:

- Page_time_out is zero.
- Page state is '11'.
- Region_id is unknown.
- Duplicate region_id in PCS.
- Region horizontal/vertical address cause off screen or overlapping graphics.
- Region horizontal address is not even.
- Regions not listed in order of incrementing vertical address.
- Total memory for visible region exceeds 60 Kbytes.
- Segment length < 2.
- Region entry incomplete (<6 bytes).

C.10.3 RCS

Possible errors relating to RCS:

- Region_id unknown.
- Duplicate RCS (same region_id) within a display set during acquisition or after a mode_change.
- Duplicate RCS (same region_id) within a display set during normal operation.
- More than eight distinct RCSs are received during acquisition or after a mode_change.
- Region width, height, depth, region_level_of_compatibility or CLUT_id are inconsistent with region definitions.
- region_width is not even during acquisition or after a mode_change.
- region_width is zero or > 720 during acquisition or after a mode_change.
- region_height is zero or > 576 during acquisition or after a mode_change.
- region_level_of_compatibility is not one of 0x01-0x03 during acquisition or after a mode_change.
- region_depth is not either 0x02 or 0x03 during acquisition or after a mode_change.

- `region_level_of_compatibility` is greater than `region_depth`.
- `object_type` is not 0x00.
- `object_provider` is not 0x00.
- Vertical and/or horizontal position are not within the region.
- Total number of objects referenced in all RCSs exceeds 128.
- Total memory for declared regions exceeds 80 Kbytes.
- Segment length < 10.
- Incomplete object entry.

C.10.4 CDS

Possible errors relating to CDS:

- `CLUT_id` unknown.
- Is not referenced in all required preceding RCSs.
- Duplicate CDS (same `CLUT_id`) within a display set.
- `CLUT_entry_id` > 15 and 4-bit/entry_`CLUT_flag` is set.
- 2-bit/entry_`CLUT_flag` is set.
- Illegal colour i.e. $Y/C_r/C_b$ out of range for 601.
- Illegal $C_r/C_b/T$ values of transparent entry.
- Segment length < 2.
- Incomplete CLUT entry.

C.10.5 ODS

Possible errors relating to ODS:

- `Object_id` is not referenced in a preceding RCS.
- Object coding method is not 0x00.
- Top field length is zero.
- Object data type is not one of 0x10-0x12, 0x20-0x22 or 0xF0.
- Object targeted at a 4-bit region contains an 8-bit/pixel_`code_string()`.
- Object extends beyond region boundaries.
- Segment length < 7.

Annex D (informative)

An example of frequencies and offsets

D.1 UHF

Where UHF IV and V bands are used, the centre frequencies f_c of the incoming DVB-T RF signals are:

$$f_c = 474 \text{ MHz} + (N - 21) \times 8 \text{ MHz} + f_{\text{offset}}$$

$$N = \{21, \dots, 69\} \text{ (UHF channel number)}$$

In some countries offsets may be used:

- In the UK, f_{offset} is $\pm 1/6$ MHz or 0 MHz.
- In France, f_{offset} is $-1/6$ MHz, 0 MHz, $+1/6$ MHz, $+1/3$ MHz or $+1/2$ MHz.
- In Sweden, f_{offset} is between -10 kHz and $+10$ kHz (continuous fine frequency offset range).

D.2 VHF

Where VHF band III is used, the centre frequencies f_c of the incoming DVB-T RF signals are:

- for countries using 8 MHz channel raster:

$$f_c = 178 \text{ MHz} + (N - 6) \times 8 \text{ MHz} + f_{\text{offset}}$$

$$N = \{6, \dots, 12\} \text{ (VHF channel number)}$$

- for countries using 7 MHz channel raster:

$$f_c = 177,5 \text{ MHz} + (N - 5) \times 7 \text{ MHz} + f_{\text{offset}}$$

$$N = \{5, \dots, 12\} \text{ (VHF channel number)}$$

In some countries, offsets may be used.

Annex E (informative)

Noise model

A useful model for calculating receiver noise performance is illustrated below. The model comprises the following representative components:

- a front-end stage with noise figure F , and 'perfect' automatic gain control (AGC);
- an excess noise source of power P_x at a point following the gain-controlled stage;
- a practical, but unimpaired demodulator; that is, a demodulator with a fast channel equaliser and a consequent implementation margin of (2 to 3) dB.

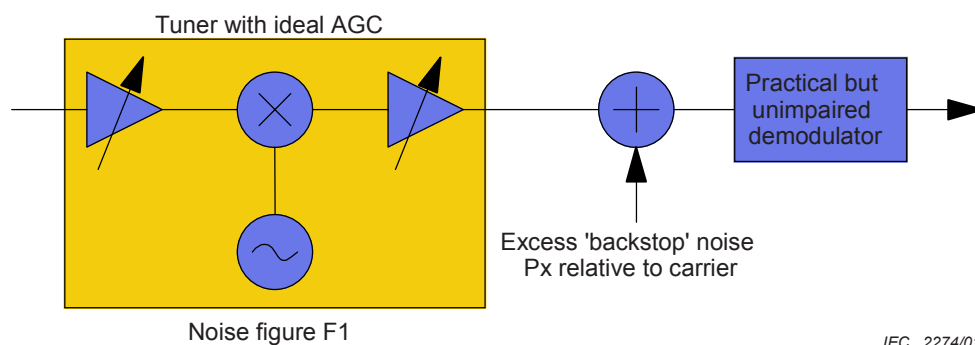

Figure E.1 – Tuner noise model

Note that the excess noise source P_x will include contributions from the following:

- local oscillator phase noise;
- quantisation noise introduced by the demodulator analogue-to-digital converter;
- backstop thermal noise;
- intermodulation products.

The carrier-to-noise ratio at the input to the model is $10 \log_{10} [C/kTB]$

The carrier-to-noise ratio at the input to the 'practical' demodulator is given by

$$C/N \text{ (dB)} = 10 \log_{10} [C/(kTB F_1 + CP_x)]$$

where

C is the signal input power;

k is the Boltzmann's constant ($k = 1,38 \times 10^{-23}$ J/K);

T is the reference temperature (290 K);

B is the system noise bandwidth (7,61 MHz or 6,65 MHz).

Annex F (informative)

An example of C/N-performance with a practical transmitter

C/N values for IL = 2,5 dB, receiver P_x = -33 dBc, transmitter ENF = -34 dBc.

Table F.1 – C/N (dB) for reference BER

| Modulation | Code rate | Gaussian | Fixed | Portable |
|------------|-----------|----------|-------|----------|
| QPSK | 1/2 | 5,6 | 6,1 | 7,9 |
| | 2/3 | 7,4 | 8,2 | 10,9 |
| | 3/4 | 8,4 | 9,3 | 13,3 |
| | 5/6 | 9,4 | 10,5 | 15,7 |
| | 7/8 | 10,2 | 11,3 | 19,1 |
| 16-QAM | 1/2 | 11,4 | 12,2 | 13,8 |
| | 2/3 | 13,7 | 14,2 | 16,9 |
| | 3/4 | 15,1 | 15,6 | 19,5 |
| | 5/6 | 16,2 | 17,1 | 22,4 |
| | 7/8 | 16,6 | 17,7 | 26,9 |
| 64-QAM | 1/2 | 17,1 | 17,4 | 18,8 |
| | 2/3 | 19,3 | 20,0 | 22,4 |
| | 3/4 | 21,0 | 21,6 | 25,4 |
| | 5/6 | 22,4 | 23,3 | 31,2 |
| | 7/8 | 23,4 | 24,5 | 49,0 |

NOTE 1 Reference BER is defined as BER = 2x10⁻⁴ after Viterbi decoding.

NOTE 2 The figures in EN 300 744 are all the result of early simulation work, and could change as a result of improved simulations.

NOTE 3 The figures for the fixed reception (“Ricean”) and portable reception (“Rayleigh”) channels make use of the information given in EN 300 744. These particular channels are too complicated for practical implementation and it is proposed that simpler channels be defined and the new figures quoted.

Annex G (informative)

Practical 6-path channel models for fixed and portable channels

G.1 Fixed reception (Ricean channel)

The following is one possible 6 tap approximation of the 1+20 tap channel of EN 300 744 Appendix B for fixed reception. The first tap corresponds to the direct ray and, hence, only 5 taps are used to describe the random behaviour. This selection has been made as some simulation equipment in the market support convenient measurement set-ups only to this extent of the channel model. The proposed model is a *Ricean channel* with $K=11,7$ dB (while DVB-T nominal is 10 dB). The result has been derived based on mean square error minimization.

Table G.1 – Approximate 6-tap channel for fixed reception (Ricean channel)

| Tap number | Delay τ μs | Amplitude r | Level dB | Phase θ rad |
|------------|-------------------------------|---------------|-------------|-----------------------|
| 1 | 0 | 1 | 0 | 0 |
| 2 | 0,475 | 0,146 | -16,7 | 0,363 |
| 3 | 0,645 | 0,119 | -18,5 | 2,739 |
| 4 | 1,933 | 0,117 | -18,6 | -0,156 |
| 5 | 2,754 | 0,089 | -21,0 | -2,239 |
| 6 | 3,216 | 0,103 | -19,7 | -0,103 |

The notation in the above corresponds to tap values of the form $r \cdot \exp(j \cdot \theta)$ where r is the amplitude and θ is the phase (note the exponent sign).

G.2 Portable reception (Rayleigh channel)

The following is one possible 6 tap approximation of the 20 tap channel of EN 300 744 Appendix B for portable reception, Rayleigh fading. The result has been derived based on low-pass filtering and selecting dominant taps. The approximation gives fairly good correspondence at low levels, which should be desirable. The fitting has been made in such a way that the signal powers after the channels are the same both for the standard model and the 6-tap approximation.

Table G.2 – Approximate 6-tap channel for portable reception (Rayleigh channel)

| Tap number | Delay τ μs | Amplitude r | Level dB | Phase θ rad |
|------------|-------------------------------|---------------|-------------|-----------------------|
| 1 | 0,050 | 0,36 | -8,87 | -2,875 |
| 2 | 0,479 | 1 | 0 | 0 |
| 3 | 0,621 | 0,787 | -2,09 | 2,182 |
| 4 | 1,907 | 0,587 | -4,63 | -0,460 |
| 5 | 2,764 | 0,482 | -6,34 | -2,616 |
| 6 | 3,193 | 0,451 | -6,92 | 2,863 |

The notation in the above, as earlier, corresponds to tap values of the form $r \cdot \exp(j \cdot \theta)$ where r is the amplitude and θ is the phase (note the sign).

Annex H (informative)

Interfering analogue signals

H.1 PAL B/G/I1

The level of the FM sound relative to the vision carrier is -13 dB. The level of the NICAM signal relative to the analogue vision carrier is -20 dB. Modulating signals are 75 % colour bars, and 1 kHz FM sound with ± 50 kHz deviation.

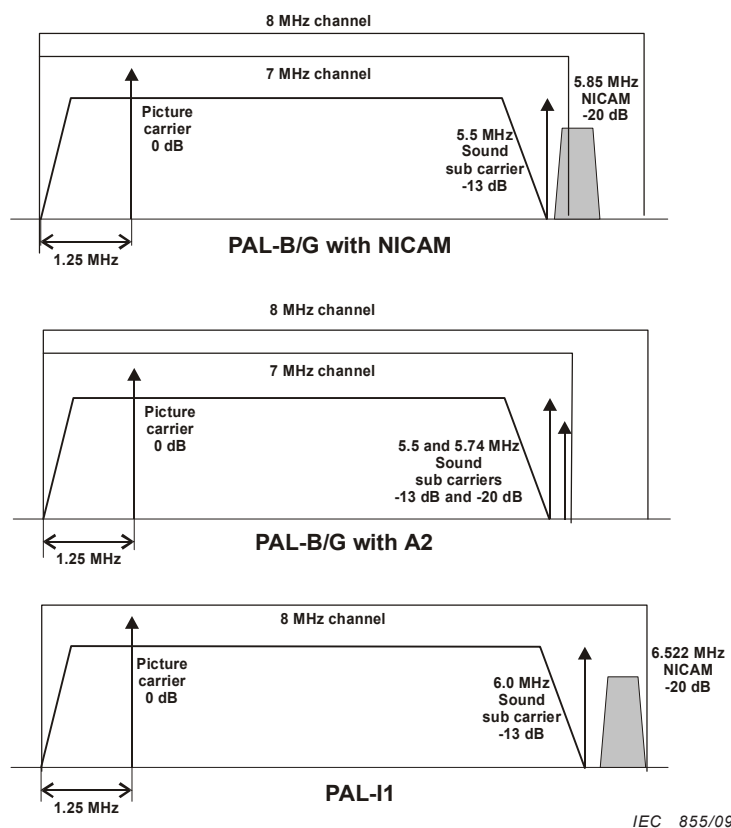

Figure H.1 – PAL interfering signals

H.2 SECAM L

Standard SECAM signal with NICAM sound (1,25 MHz vestigial sideband bandwidth).

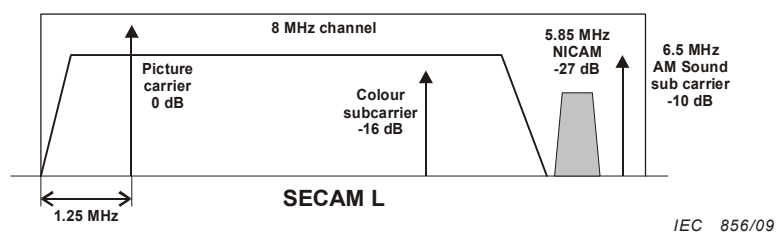

Figure H.2 – SECAM L interfering signal

The level of the sound subcarrier is -10 dB relative to the picture carrier. The level of the NICAM signal relative to the analogue vision carrier is -27 dB. Modulating signals are 75 % colour bars for the picture carrier and 1 kHz with 54 % AM for the AM sound carrier.

Bibliography

A011 rev.1, *DVB Common Scrambling Algorithm – Distribution agreements*

D-Book, *Digital Terrestrial Television, Requirements for interoperability, Issue 3.0*, Digital TV Group, available at <www.dtg.org.uk>

High-Definition Multimedia Interface™, Specification Version 1.3, HDMI Licensing, LLC, available at <www.hdmi.org>

High-Bandwidth Digital Content Protection System, Version 1.3, Digital Content Protection, LLC, available at <www.digital-cp.com>

British Standards Institution (BSI)

BSI is the independent national body responsible for preparing British Standards and other standards-related publications, information and services.

It presents the UK view on standards in Europe and at the international level.

It is incorporated by Royal Charter.

Revisions

British Standards are updated by amendment or revision. Users of British Standards should make sure that they possess the latest amendments or editions.

It is the constant aim of BSI to improve the quality of our products and services. We would be grateful if anyone finding an inaccuracy or ambiguity while using this British Standard would inform the Secretary of the technical committee responsible, the identity of which can be found on the inside front cover.

Tel: +44 (0)20 8996 9001 Fax: +44 (0)20 8996 7001

BSI offers Members an individual updating service called PLUS which ensures that subscribers automatically receive the latest editions of standards.

Tel: +44 (0)20 8996 7669 Fax: +44 (0)20 8996 7001

Email: plus@bsigroup.com

Buying standards

You may buy PDF and hard copy versions of standards directly using a credit card from the BSI Shop on the website www.bsigroup.com/shop. In addition all orders for BSI, international and foreign standards publications can be addressed to BSI Customer Services.

Tel: +44 (0)20 8996 9001 Fax: +44 (0)20 8996 7001

Email: orders@bsigroup.com

In response to orders for international standards, it is BSI policy to supply the BSI implementation of those that have been published as British Standards, unless otherwise requested.

Information on standards

BSI provides a wide range of information on national, European and international standards through its Knowledge Centre.

Tel: +44 (0)20 8996 7004 Fax: +44 (0)20 8996 7005

Email: knowledgecentre@bsigroup.com

Various BSI electronic information services are also available which give details on all its products and services.

Tel: +44 (0)20 8996 7111 Fax: +44 (0)20 8996 7048

Email: info@bsigroup.com

BSI Subscribing Members are kept up to date with standards developments and receive substantial discounts on the purchase price of standards. For details of these and other benefits contact Membership Administration.

Tel: +44 (0)20 8996 7002 Fax: +44 (0)20 8996 7001

Email: membership@bsigroup.com

Information regarding online access to British Standards via British Standards Online can be found at www.bsigroup.com/BSOL

Further information about BSI is available on the BSI website at www.bsigroup.com/standards

Copyright

Copyright subsists in all BSI publications. BSI also holds the copyright, in the UK, of the publications of the international standardization bodies. Except as permitted under the Copyright, Designs and Patents Act 1988 no extract may be reproduced, stored in a retrieval system or transmitted in any form or by any means – electronic, photocopying, recording or otherwise – without prior written permission from BSI. This does not preclude the free use, in the course of implementing the standard of necessary details such as symbols, and size, type or grade designations. If these details are to be used for any other purpose than implementation then the prior written permission of BSI must be obtained. Details and advice can be obtained from the Copyright & Licensing Manager.

Tel: +44 (0)20 8996 7070

Email: copyright@bsigroup.com

BSI Group Headquarters

389 Chiswick High Road London W4 4AL UK

Tel +44 (0)20 8996 9001

Fax +44 (0)20 8996 7001

www.bsigroup.com/standards