

Hollow pressurized and unpressurized ceramic and glass insulators for use in electrical equipment with rated voltages greater than 1000 V

The European Standard EN 62155:2003 has the status of a
British Standard

ICS 29.080.10

National foreword

This British Standard is the official English language version of EN 62155:2003. It is identical with IEC 62155:2003. It supersedes BS 4963:1973 and BS EN 61264:1999, which will be withdrawn on 2006-05-01.

The UK participation in its preparation was entrusted by Technical Committee PEL/36, Insulators for power systems, to Subcommittee PEL/36/3, Substation insulators, which has the responsibility to:

- aid enquirers to understand the text;
- present to the responsible European committee any enquiries on the interpretation, or proposals for change, and keep the UK interests informed;
- monitor related international and European developments and promulgate them in the UK.

A list of organizations represented on this subcommittee can be obtained on request to its secretary.

Cross-references

The British Standards which implement international or European publications referred to in this document may be found in the *BSI Catalogue* under the section entitled “International Standards Correspondence Index”, or by using the “Search” facility of the *BSI Electronic Catalogue* or of British Standards Online.

This publication does not purport to include all the necessary provisions of a contract. Users are responsible for its correct application.

Compliance with a British Standard does not of itself confer immunity from legal obligations.

Summary of pages

This document comprises a front cover, an inside front cover, the EN title page, pages 2 to 52, an inside back cover and a back cover.

The BSI copyright notice displayed in this document indicates when the document was last issued.

Amendments issued since publication

Amd. No.	Date	Comments
15282 Corrigendum No. 1	26 July 2004	See National foreword

This British Standard was published under the authority of the Standards Policy and Strategy Committee on 30 October 2003

© BSI 26 July 2004

ISBN 0 580 42838 9

EUROPEAN STANDARD

EN 62155

NORME EUROPÉENNE

EUROPÄISCHE NORM

August 2003

ICS 29.080.10

Supersedes HD 329 S1:1977 & EN 61264:1998

English version

**Hollow pressurized and unpressurized
ceramic and glass insulators
for use in electrical equipment
with rated voltages greater than 1 000 V
(IEC 62155:2003, modified)**

Isolateurs creux avec ou sans pression interne, en matière céramique ou en verre, pour utilisation dans des appareillages prévus pour des tensions nominales supérieures à 1 000 V (CEI 62155:2003, modifiée)

Druckbeanspruchte und drucklose Hohlisolatoren aus keramischem Werkstoff und Glas für Anwendungen in elektrischen Betriebsmitteln mit Nennspannungen über 1 000 V (IEC 62155:2003, modifiziert)

This European Standard was approved by CENELEC on 2003-05-01. CENELEC members are bound to comply with the CEN/CENELEC Internal Regulations which stipulate the conditions for giving this European Standard the status of a national standard without any alteration.

Up-to-date lists and bibliographical references concerning such national standards may be obtained on application to the Central Secretariat or to any CENELEC member.

This European Standard exists in three official versions (English, French, German). A version in any other language made by translation under the responsibility of a CENELEC member into its own language and notified to the Central Secretariat has the same status as the official versions.

CENELEC members are the national electrotechnical committees of Austria, Belgium, Czech Republic, Denmark, Finland, France, Germany, Greece, Hungary, Iceland, Ireland, Italy, Lithuania, Luxembourg, Malta, Netherlands, Norway, Portugal, Slovakia, Spain, Sweden, Switzerland and United Kingdom.

CENELEC

European Committee for Electrotechnical Standardization
Comité Européen de Normalisation Electrotechnique
Europäisches Komitee für Elektrotechnische Normung

Central Secretariat: rue de Stassart 35, B - 1050 Brussels

Foreword

The text of document 36C/143/FDIS, future edition 1 of IEC 62155, prepared by SC 36C, Insulators for substations, of IEC TC 36, Insulators, was submitted to the IEC-CENELEC parallel vote and was approved by CENELEC as EN 62155 on 2003-05-01.

A draft amendment, prepared by Reporting Secretariat SR 36C, was submitted to the formal vote and was approved by CENELEC for inclusion into EN 62155 on 2003-05-01.

This European Standard supersedes HD 329 S1:1977, EN 61264:1998 and its corrigendum July 2000.

The following dates were fixed:

- latest date by which the EN has to be implemented at national level by publication of an identical national standard or by endorsement (dop) 2004-03-01
- latest date by which the national standards conflicting with the EN have to be withdrawn (dow) 2006-05-01

Annexes designated "normative" are part of the body of the standard.

Annexes designated "informative" are given for information only.

In this standard, annex ZA is normative and annexes A to D and ZB are informative.

Annexes ZA and ZB have been added by CENELEC.

Endorsement notice

The text of the International Standard IEC 62155:2003 was approved by CENELEC as a European Standard without any modification.

In the official version, for Bibliography, the following notes have to be added for the standard indicated:

ISO 9001	NOTE	Harmonized as EN ISO 9001:1994, which is superseded by EN ISO 9001:2000 (ISO 9001:2000) (not modified)
ISO 9002	NOTE	Harmonized as EN ISO 9002:1994 (not modified)
ISO 9003	NOTE	Harmonized as EN ISO 9003:1994 (not modified)
IEC 60672-1	NOTE	Harmonized as EN 60672-1:1995 (not modified)
ISO 9004	NOTE	Harmonized as EN ISO 9004:2000 (not modified)
IEC 60273	NOTE	Harmonized as HD 578 S1:1992 (not modified)
IEC 60437	NOTE	Harmonized as EN 60437:1997 (not modified)
IEC 60507	NOTE	Harmonized as EN 60507:1993 (not modified)

CONTENTS

1	Scope and object.....	5
1.1	General.....	5
1.2	Hollow insulators or hollow insulator bodies intended for general use.....	5
1.3	Ceramic hollow insulators intended for use with permanent gas pressure.....	6
2	Normative references	6
3	Terms and definitions	7
4	Insulating materials	10
5	General recommendations for design	10
5.1	General recommendations for design of hollow insulators and hollow insulator bodies intended for general use	10
5.2	Design rules for hollow insulators and hollow insulator bodies for use with permanent gas pressure.....	10
6	Classification of the tests, sampling rules and procedures	13
6.1	Classification of the tests	13
6.2	Relevant tests for type, sample and routine tests	14
6.3	Hollow insulator or hollow insulator body selection	15
6.4	Retest procedure for sample tests	16
6.5	Quality assurance	16
7	General test procedures and requirements	17
7.1	Verification of the dimensions and roughness of ground surfaces.....	17
7.2	Mechanical failing load tests.....	22
7.3	Temperature cycle test.....	25
7.4	Porosity test.....	27
7.5	Galvanizing test	28
8	Type tests	29
8.1	Tests.....	29
8.2	Pressure test.....	30
8.3	Bending test.....	30
9	Sample tests	31
9.1	Tests for hollow insulators or hollow insulator bodies intended for general use.....	31
9.2	Tests for ceramic hollow insulators or hollow insulator bodies intended for use with permanent gas pressure.....	31
10	Routine tests	31
10.1	Tests for hollow insulators or hollow insulator bodies intended for general use.....	31
10.2	Tests for ceramic hollow insulators or hollow insulator bodies intended for use with permanent gas pressure.....	32
10.3	Routine visual inspection.....	32
10.4	Electrical routine test.....	33
10.5	Routine mechanical tests for hollow insulators or hollow insulator bodies intended for general use.....	34
10.6	Routine mechanical tests for ceramic hollow insulators or hollow insulator bodies intended for use with permanent gas pressure	35
10.7	Routine thermal shock test.....	36

11	Documentation	36
11.1	Marking	36
11.2	Records	36
	Annex A (informative) Methods of testing for tolerances of parallelism, coaxiality, eccentricity, angular deviation, camber and shed angle of hollow insulators or hollow insulator bodies	37
	Annex B (informative) Methods for bending tests of hollow insulator bodies	43
	Annex C (informative) Alternative test method for the temperature-cycle test	46
	Annex D (informative) Bending moment equivalent to the design pressure	47
	Annex ZA (normative) Normative references to international publications with their corresponding European Publications	48
	Annex ZB (informative) A-deviations	50
	Bibliography	52
	Figure 1 – Bending moments	12
	Figure 2 – Tolerance of wall thickness	18
	Figure 3 – Deviation from roundness of inner or outer core diameter	19
	Figure 4 – Effect of camber of the hollow insulator body	20
	Figure 5 – Tolerance on height of sanding and porcelain chamfered end flange	21
	Figure 6 – Definition of thickness ϕ mm for temperature-cycle test	25
	Figure A.1 – Measuring of tolerances of form and position	38
	Figure A.2 – Measuring of angular deviation of fixing holes	38
	Figure A.3 – Method for measuring camber	39
	Figure A.4 – Measuring shed angle	40
	Figure A.5 – Centring with conical shank screws	40
	Figure A.6 – Axial run-out	41
	Figure A.7 – Parallelism and perpendicularity	41
	Figure A.8 – Coaxiality and concentricity, evenness, alignment of fixing holes and proper sealing	42
	Figure B.1 – Test ram for uniform distributed bending moment	43
	Figure B.2 – Test ram for non-uniform distributed bending moment	44
	Figure B.3 – Test method with bending load applied	45
	Figure C.1 – Alternative test arrangement for the temperature-cycle test	46
	Figure D.1 – Diameters for determining the equivalent bending moment to the design pressure	47
	Table 1 – Typical examples of load combinations and weighting factors	12
	Table 2 – Hollow insulators or hollow insulator bodies intended for general use – Relevant tests for type, sample and routine tests	14
	Table 3 – Ceramic hollow insulators or hollow insulator bodies intended for use with permanent gas pressure – Relevant tests for type, sample and routine tests	15
	Table 4 – Number of samples for sample tests	16
	Table 5 – Selection of temperature difference for temperature cycle test	26
	Table 6 – Selection of temperature difference for the alternative temperature-cycle test	26
	Table 7 – Selection of temperature difference for insulators of annealed glass	27

HOLLOW PRESSURIZED AND UNPRESSURIZED CERAMIC AND GLASS INSULATORS FOR USE IN ELECTRICAL EQUIPMENT WITH RATED VOLTAGES GREATER THAN 1 000 V

1 Scope and object

1.1 General

This standard is applicable to

- ceramic and glass hollow insulators intended for general use in electrical equipment;
- ceramic hollow insulators intended for use with a permanent gas pressure in switchgear and controlgear.

These insulators are intended for indoor and outdoor use in electrical equipment, operating on alternating current with a rated voltage greater than 1 000 V and a frequency not greater than 100 Hz or for use in direct-current equipment with a rated voltage of greater than 1 500 V.

The hollow insulators are intended for use in electrical equipment, for example:

- circuit-breakers,
- switch-disconnectors,
- disconnectors,
- earthing switches,
- instrument transformers,
- surge arresters,
- bushings,
- cable sealing ends,
- capacitors.

It is not the object of this standard to prescribe dielectric type tests because the withstand voltages are not characteristics of the hollow insulator itself but of the apparatus of which it ultimately forms a part.

1.2 Hollow insulators or hollow insulator bodies intended for general use

Hollow insulators or insulator bodies of ceramic material or glass, intended for use

- without pressure;
- with permanent pressure ≤ 50 kPa gauge;
- with permanent gas pressure > 50 kPa gauge in combination with an internal volume < 1 l ($1\,000$ cm³);
- with permanent hydraulic pressure.

The object of this standard is to define

- the terms used;
- the mechanical and dimensional characteristics of hollow insulators and hollow insulator bodies;
- the electrical soundness of the wall;
- the conditions under which the specified values of these characteristics are verified;
- the methods of test;
- the acceptance criteria.

1.3 Ceramic hollow insulators intended for use with permanent gas pressure

Hollow insulators or hollow insulator bodies with their fixing devices, intended for use with permanent gas pressure: permanent gas pressure >50 kPa gauge in combination with an internal volume ≥ 1 l (1 000 cm³).

NOTE 1 The gas can be dry air, inert gases, for example, SF₆ or nitrogen or a mixture of such gases.

The object of this standard is to define

- the terms used;
- the mechanical and dimensional characteristics of hollow insulators and hollow insulator bodies;
- the electrical soundness of the wall;
- the conditions under which the specified values of these characteristics are verified;
- the methods of test;
- the acceptance criteria;
- design rules;
- test procedures and test values.

NOTE 2 Hollow insulators or hollow insulator bodies are usually integrated into electrical equipment which is electrically type tested as required by the equipment standard.

2 Normative references

The following referenced documents are indispensable for the application of this document. For dated references, only the edition cited applies. For undated references, the latest edition of the referenced document (including any amendments) applies.

IEC 60672-3:1997, *Ceramic and glass insulating materials – Part 3: Specifications for individual materials*

IEC 60694:1996, *Common specifications for high-voltage switchgear and controlgear standards*

IEC 60865-1:1993, *Short-circuit currents – Calculation of effects – Part 1: Definitions and calculation methods*

IEC 61166:1993, *High-voltage alternating current circuit-breakers – Guide for seismic qualification of high-voltage alternating current circuit-breakers*

IEC 61463:1996, *Bushings – Seismic qualification*

IEC 62271-100:2001, *High-voltage switchgear and controlgear – Part 100: High-voltage alternating-current circuit-breakers*

ISO 1460:1992, *Metallic coatings – Hot dip galvanized coatings on ferrous metals – Gravimetric determination of the mass per unit area*

ISO 1461:1999, *Hot dip galvanized coatings on fabricated iron and steel articles – Specifications and test methods*

ISO 1463:1982, *Metal and oxide coatings – Measurement of coating thickness – Microscopical method*

ISO 2064:1996, *Metallic and other inorganic coatings – Definitions and conventions concerning the measurement of thickness*

ISO 2178:1982, *Non-magnetic coatings on magnetic substrates – Measurement of coating thickness – Magnetic method*

ISO 4287:1997, *Geometrical Product Specifications (GPS) – Surface texture: Profile method – Terms, definitions and surface texture parameters*

3 Terms and definitions

For the purposes of this document, the following definitions apply.

NOTE Some of the definitions cited below are taken from IEC 60050(471), modified or unmodified.

3.1

hollow insulator body

hollow insulating body, which is open from end to end, with or without sheds, not including the fixing devices or end fittings

3.2

hollow insulator

hollow insulating part, which is open from end to end, with or without sheds, including the fixing devices or end fittings

[IEV 471-01-17, modified]

NOTE This is a general term which also covers the definitions 3.4, 3.5 and 3.6.

3.3

fixing device

end fitting

device forming part of a hollow insulator, intended to connect it to a supporting structure or to an item of equipment, or to another insulator

NOTE Where the fixing device is metallic, the term “metal fitting” is also used.

[IEV 471-01-02, modified]

3.4

hollow post insulator

hollow post insulator, which consists of one hollow post insulator unit or an assembly of more units and is intended to give support to a live part, which is to be insulated from earth or from another live part

3.5**hollow post insulator unit**

hollow post insulator unit, which consists of a permanent assembly of a hollow insulating body with fixing devices and is intended to give support

3.6**chamber insulator**

hollow insulator, which is used as a housing

EXAMPLE Arc extinction chamber of a circuit-breaker.

3.7**bushing**

device that enables one or several conductors to pass through a partition such as a wall or tank and insulates the conductors from it

[IEV 471-02-01, modified]

NOTE The means of attachment (flange or other fixing device) to the partition forms part of the bushing.

3.8**puncture**

disruptive discharge passing through the solid insulating material of the insulator which produces a permanent loss of dielectric strength

[IEV 471-01-11]

3.9**creepage distance**

shortest distance along the external surface of an insulator between two conductive parts

[IEV 471-01-08, modified]

NOTE 1 The surface of cement, or of other non-insulating jointing material, is not considered as forming part of the creepage distance.

NOTE 2 If a high-resistance coating is applied to parts of the surface of an insulator, such parts are considered to be effective insulating surfaces, and the distance over them is included in the creepage distance.

NOTE 3 The surface resistivity of such high-resistance coatings is usually about $10^6 \Omega$ but may be as low as $10^8 \Omega$.

NOTE 4 If high-resistance coatings are applied to the whole surface of an insulator (the so-called stabilized insulator), the questions of surface resistivity and creepage distance should be subject to agreement between the purchaser and the manufacturer.

3.10**specified characteristic**

- either the numeric value of a voltage, of a mechanical load, or any other characteristic specified in an IEC standard,
- or the numeric value of any such characteristic agreed between the purchaser and the manufacturer

3.11**withstand bending moment**

withstand bending moment verified in a type test, which is based on load conditions specified for the hollow insulator

NOTE For a pressurized hollow insulator, it is based on the load conditions specified in 5.2.

3.12**mechanical failing load**

maximum load reached when a hollow insulator or hollow insulator body is tested under the prescribed conditions of test

3.13**design pressure**

upper limit at least of differential pressure reached between the interior and exterior of the hollow insulator during operation at the design temperature

3.14**design temperature**

highest temperature reached inside the hollow insulator which can occur under service conditions

NOTE This is generally the upper limit of ambient air temperature increased by the temperature rise due to the flow of the rated normal current, and to dielectric losses, if any.

3.15**manufacturer**

organization that produces the hollow insulators or hollow insulator bodies

3.16**equipment manufacturer**

individual or organization which produces the electrical equipment utilizing the hollow insulators or hollow insulator bodies

3.17**parallelism of the end faces**

maximum difference in the height of a hollow insulator measured across the surfaces of the end fittings or the surfaces of the hollow insulator body

3.18**eccentricity**

displacement, perpendicular to the axis of the hollow insulator, between the centres of the pitch circles of the fixing holes in the top and bottom metal fittings

3.19**axial run-out**

relative axial displacement of the end faces of the insulator measured during one revolution (see Figure A.6)

3.20**angular deviation of the fixing holes**

rotational displacement, expressed as an angle, between corresponding fixing holes in the end fittings at the top and bottom of a hollow insulator

3.21**camber of an insulator**

maximum distance between the theoretical axis of an insulator and the curved line being the locus of the centres of all the transverse cross-sections of the unloaded insulator

[IEV 471-01-19]

3.22**lot**

group of hollow insulators or hollow insulator bodies offered for acceptance from the same manufacturer, of the same design and manufactured under similar conditions of production

NOTE One or more lots may be offered together for acceptance; the lot(s) offered may consist of the whole, or part, of the quantity ordered.

4 Insulating materials

The insulating materials of hollow insulator bodies intended for general use (see 1.2) covered by this standard are:

- ceramic material, porcelain;
- annealed glass, being glass in which the mechanical stresses have been relaxed by thermal treatment;
- toughened glass, being glass in which controlled mechanical stresses have been induced by thermal treatment.

The insulating materials of hollow insulator bodies intended for use with permanent gas pressure (see 1.3) covered by this standard are:

- ceramic material complying in its characteristics with IEC 60672-3, group C-100 and C-200.

NOTE 1 Further information on the definition and classification of ceramic and glass insulating materials can be found in other IEC publications (see [4]¹).

NOTE 2 The term “ceramic material” is used in this standard to refer to porcelain materials and, contrary to North American practice, does not include glass.

5 General recommendations for design

5.1 General recommendations for design of hollow insulators and hollow insulator bodies intended for general use

Specific design rules are not prescribed since the requirements are a function of the equipment application (see 1.2).

5.2 Design rules for hollow insulators and hollow insulator bodies for use with permanent gas pressure

5.2.1 Purpose

The rules for the design of gas-pressurized hollow insulators for high-voltage equipment prescribed in this clause take into account that these hollow insulators are subjected to particular operating conditions which distinguish them from compressed air receivers and other similar storage vessels (see 1.3).

5.2.2 Rules for design

When designing hollow insulators, the following points shall be taken into consideration.

- Deviations and tolerances of profile: circularity, run-out, camber, parallelism, coaxiality, evenness, differences in wall thickness, and angular and radial position of fixing holes shall all take account of the parts to be fitted inside.
- It shall be considered that electrical strength, mechanical strength and technological problems may influence the real construction, but, due to the complexity of this subject, no definitive guide can be given.
- A critical selection of materials for cementing and fittings is also necessary. The ceramic material shall comply in its characteristics with IEC 60672-3, group C-100 and C-200.

¹ Figures in square brackets refer to the bibliography.

- An insulating pressurized enclosure may be considered as appropriate for its intended use only after the electrical equipment of which it is a part has satisfactorily passed the type tests provided for by the particular standards with which this equipment must comply.

5.2.3 Determination of the design pressure

The design pressure shall be the difference between the maximum absolute pressure, when the equipment (of which the hollow insulator is a part) is carrying its rated normal current at maximum ambient temperature and the outside pressure.

The maximum absolute pressure of the gas inside the hollow insulator shall be determined by the equipment manufacturer.

NOTE In some special cases (for example, circuit-breakers), the pressure rise occurring after a breaking operation should be taken into account.

5.2.4 Determination of the design temperature

The equipment manufacturer shall determine this value taking account of 3.14.

Solar radiation shall be taken into account.

5.2.5 Determination of the type-test withstand bending moment

The following factors may all contribute to the bending stress that may occur in electrical equipment: mass, internal pressure, terminal loads, short-circuit loads, ice loads, operating loads, wind loads, seismic loads (see Table 1).

The following sources shall be used for determining the values necessary for calculating the relevant loads:

- terminal loads: 6.101.6.1 of IEC 62271-100
- wind loads: 6.101.6.1 of IEC 62271-100 and 2.1.2 of IEC 60694
- ice loads: 6.101.6.1 of IEC 62271-100 and 2.1.2 of IEC 60694
- short-circuit loads: determined from the rated short-circuit level of the equipment (section 2 of IEC 60865-1)
- seismic loads: 8.1 of IEC 61166 and 10.1 of IEC 61463
- operating loads: values depending on design of equipment

The alternative combinations detailed in Table 1 are typical examples of load combinations that must be considered in design. Column 1 of Table 1 covers the routinely expected loads and has been assigned a safety factor of 2,1 for the type-test bending stress.

The three other conditions covering rarely occurring extreme loads have been assigned safety factors of 1,2 for the type-test bending stress, and for seismic stresses a safety factor of 1,0.

The most onerous of the applicable alternatives shall be used to determine the test withstand bending stress.

From the test withstand bending stress, the test withstand bending moment can be calculated.

Table 1 – Typical examples of load combinations and weighting factors

Loads	Stress from routinely expected loads	Stress from rarely occurring extreme loads		
		Alternative 1 Short-circuit load	Alternative 2 Ice load	Alternative 3 Seismic load
Design pressure ^a	100 %	100 %	100 %	100 %
Mass	100 %	100 %	100 %	100 %
Rated terminal load	100 %	50 %	0 %	70 %
Wind pressure	30 %	100 %	0 %	10 %
Short-circuit load	0 %	100 %	0 %	0 %
Ice load	0 %	0 %	100 %	0 %
Seismic load	0 %	0 %	0 %	100 %
Safety factor	2,1	1,2	1,2	1,0

NOTE For details see IEC 62271-100, IEC 60694, IEC 60865-1, IEC 61166 and IEC 61463.

^a See Annex D.

Figure 1 shows the relation between the testing values and the utilization values for the bending moment of a hollow insulator.

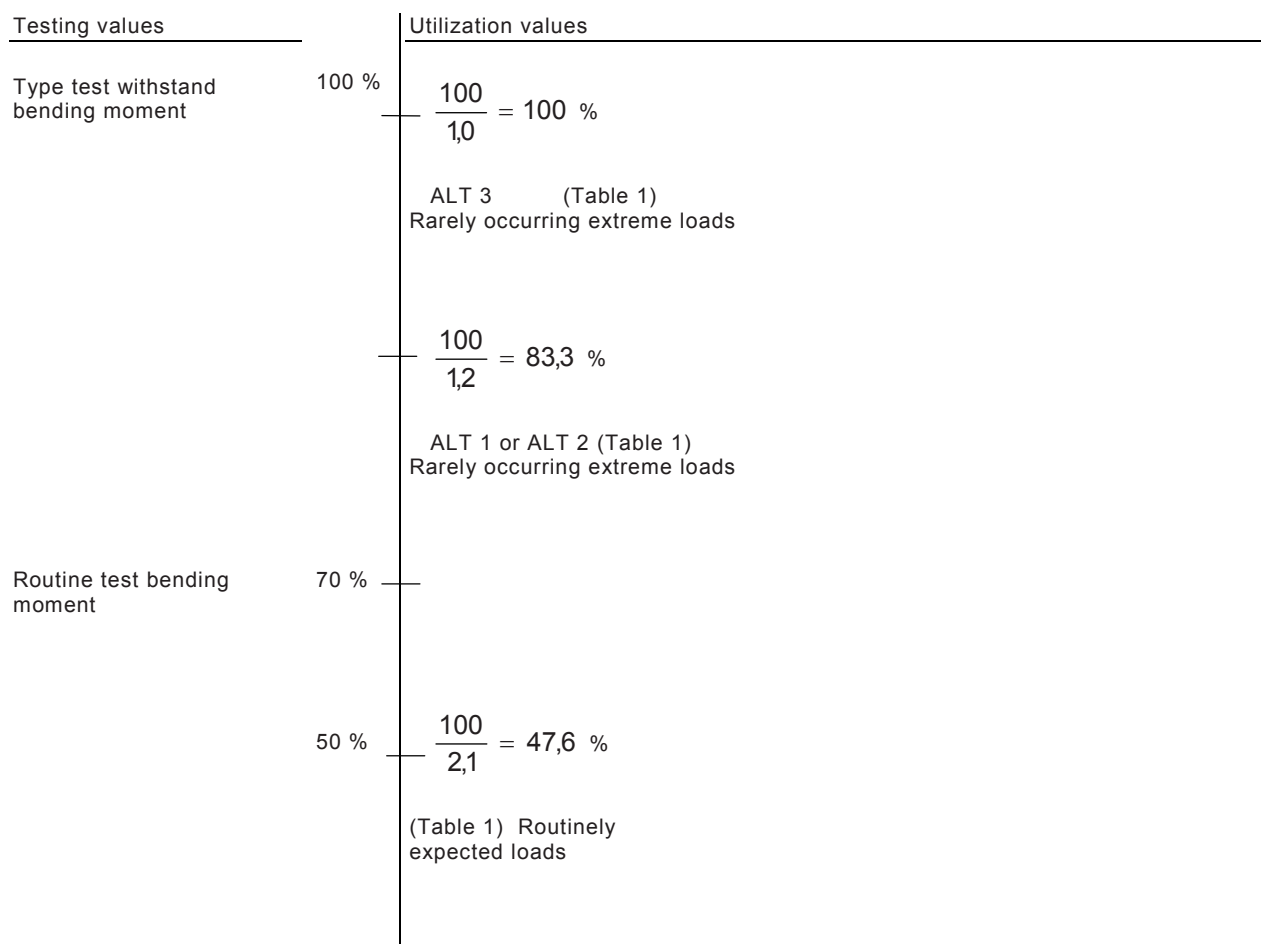

Figure 1 – Bending moments

6 Classification of the tests, sampling rules and procedures

6.1 Classification of the tests

The tests are divided into three groups as follows.

- a) Type tests
- b) Sample tests
- c) Routine tests

6.1.1 Type tests

The type tests are intended to verify the main characteristics of a hollow insulator and/or a hollow insulator body, which depend mainly on its design. They are usually carried out on one hollow insulator and/or hollow insulator body, and only once for a new design or manufacturing process, and then subsequently repeated only when the design, material or manufacturing process is changed; when the change only affects certain characteristics, only the test(s) relevant to those characteristics need to be repeated. Moreover, it is not necessary to perform all the type tests on a new design of hollow insulator and/or hollow insulator body if a test report is available for a hollow insulator and/or hollow insulator body of mechanically equivalent design. A mechanically equivalent design is the hollow insulator or hollow insulator body having identical manufacturing and design parameters, and having the following characteristics:

- the internal and external core diameters are the same;
- the design of the connection between the insulating component and the end fitting is the same;
- the shape and size of the parts of the end fittings which connect to the insulating components are the same;
- the nominal height does not differ by more than $\pm 20\%$.

NOTE 1 Since all factors (materials, manufacturing process, and dimensions) which influence the mechanical strength of hollow insulators or hollow insulator bodies should be the same for mechanical equivalence, the value of the bending moment strength, the tensile strength, and the torsional strength will then be the same as those for hollow insulators or hollow insulator bodies of mechanically equivalent designs, by which they are represented.

NOTE 2 When establishing mechanical equivalence of design, the effect of a significant difference in nominal external diameter due to change of shed overhang and of shed spacing may need to be considered.

The type tests shall be carried out on hollow insulators and/or hollow insulator bodies which meet the requirements of all the routine tests. When the insulators for type tests are taken from a lot offered for acceptance, they shall also serve as sample tests for that lot.

6.1.2 Sample tests

The sample tests are carried out to verify the characteristics of a hollow insulator and/or hollow insulator body, which can vary with the manufacturing process and the quality of the component materials of the hollow insulator and/or hollow insulator body. Sample tests are used as acceptance tests on a sample of hollow insulators and/or hollow insulator bodies, taken at random from a lot which has met the requirements of the relevant routine tests.

6.1.3 Routine tests

The routine tests are intended to eliminate defective units and are carried out during the manufacturing process. Routine tests shall be carried out on each hollow insulator and/or hollow insulator body.

6.2 Relevant tests for type, sample and routine tests

All hollow insulators or hollow insulator bodies intended for general use shall be tested according to tests given in Table 2.

All hollow insulators or hollow insulator bodies intended for use with permanent gas pressure shall be tested according to tests given in Table 3.

The series of tests to be conducted shall verify the characteristics of the hollow insulator or hollow insulator body, which are specified on the drawing. In addition, the purchaser and the manufacturer may agree to make tests other than those specified.

Additional routine tests such as verification of relevant dimensions (7.1) and mechanical tests (10.5) may be performed after agreement between manufacturer and purchaser.

Table 2 – Hollow insulators or hollow insulator bodies intended for general use – Relevant tests for type, sample and routine tests

Tests	Tests specified in Subclause	Type tests in Clause 8	Sample tests in Clause 9	Routine tests in Clause 10
Verification of dimensions and roughness of ground surfaces	7.1	–	x	–
Mechanical failing load test	7.2	x ^a	x ^a	–
Temperature-cycle test	7.3	x ^f	x	–
Porosity test	7.4	–	x ^b	–
Galvanizing test	7.5	–	x ^c	–
Visual examination	10.3	–	–	x
Electrical routine test	10.4	–	–	x
Mechanical routine test	10.5	–	–	x ^e
Routine thermal shock test	10.7	–	–	x ^d
x Required by this standard.				
<p>^a This test is to verify the mechanical performance of the hollow insulator or hollow insulator body when defined by the relevant drawing. Such tests shall be carried out after the temperature-cycle test.</p> <p>^b Applicable only to ceramic insulators.</p> <p>^c Applicable only to hollow insulators assembled with hot dip galvanized metal fittings.</p> <p>^d Applicable only to toughened glass insulators.</p> <p>^e Applicable only when specified on the drawing.</p> <p>^f Applicable only when mechanical failing load test is specified.</p>				

Table 3 – Ceramic hollow insulators or hollow insulator bodies intended for use with permanent gas pressure – Relevant tests for type, sample and routine tests

Tests	Tests specified in Subclause	Type tests in Clause 8	Sample tests in Clause 9	Routine tests in Clause 10
Verification of dimensions and roughness of ground surfaces	7.1	–	x	–
Mechanical failing load test	7.2	x ^a	x ^a	–
Temperature-cycle test	7.3	x	x	–
Porosity test	7.4	–	x	–
Galvanizing test	7.5	–	x ^b	–
Visual examination	10.3	–	–	x
Electrical routine test	10.4	–	–	x
Mechanical routine test	10.6.1; 10.6.2	–	–	x
Other mechanical tests	10.6.3	–	–	x ^c
x Required by this standard.				
<p>^a This test is to verify the mechanical performance of the hollow insulator or hollow insulator body as defined in 7.2 and by the relevant drawing. Such tests shall be carried out after the temperature cycle test. The pressure and bending tests are compulsory.</p> <p>^b Applicable only to hollow insulators assembled with hot dip galvanized metal fittings.</p> <p>^c Applicable only when specified on the drawing.</p>				

6.3 Hollow insulator or hollow insulator body selection

6.3.1 Hollow insulator or hollow insulator body selection for type tests

One hollow insulator or hollow insulator body shall be subjected to each test. The test shall be carried out on an insulator which has passed all the requirements for the routine and sample tests, except the sample mechanical test. Insulators which have been submitted to type tests which may affect their mechanical characteristics shall not be used in service.

Normally the manufacturer selects the hollow insulator or hollow insulator body used for the type test. If type and sample tests (see 6.1.1 and 6.1.2) are carried out consecutively, the purchaser may make the selection.

6.3.2 Hollow insulator or hollow insulator body selection for sample tests

The number of hollow insulators or hollow insulator bodies selected for test shall be in accordance with Table 4. The purchaser may make the selection from a lot which meets the requirements of the routine tests.

Insulators which have been submitted to sample tests which may affect their mechanical characteristics shall not be used in service.

Table 4 – Number of samples for sample tests

Number of insulators in the lot, n	Number of samples
$n \leq 100$	1 or by agreement
$100 < n \leq 500$	1 % ^a
$500 < n$	$4 + 1,5 \times \frac{n}{1\ 000}$ ^a
^a If the percentage or calculation does not give a whole number, then the next whole number above shall be chosen.	

6.4 Retest procedure for sample tests

If only one hollow insulator or hollow insulator body or metal fitting fails to comply with any of the sample tests, a new sample, equal to twice the quantity originally submitted to that test, shall be subjected to retesting. The retesting shall comprise the test in which failure occurred, preceded by those tests which may be considered as having influenced the results of the original test.

If two or more hollow insulators or hollow insulator bodies or metal fittings fail to comply with any of the sample tests or if any failure occurs during the retesting, the complete lot is considered as not complying with this standard and shall be withdrawn by the manufacturer.

Provided the cause of the failure can be clearly identified, the manufacturer may sort the lot to eliminate all the hollow insulators or hollow insulator bodies with that defect. The sorted lot, or part thereof, may then be re-submitted for testing.

The number then selected shall be three times the first quantity chosen for the tests. The retesting shall comprise the test in which failure occurred, preceded by those tests which may be considered as having influenced the results of the original test. If any hollow insulator or hollow insulator body fails during this retesting, the complete lot is considered as not complying with this standard.

NOTE 1 Where failure in the galvanizing test is due to a mechanical load in a previous test in excess of the routine test load, the retest may be carried out, either on unassembled metal fittings, or on other hollow insulators in the lot.

NOTE 2 If, during the sample testing, one or more hollow insulators or hollow insulator bodies fail to comply with the tolerances as specified in 7.1 or on the relevant drawing, then, by agreement between the purchaser and the manufacturer, the tolerances of each hollow insulator or hollow insulator body may be checked.

6.5 Quality assurance

A quality assurance programme, taking into account the requirements of this standard, can be used, after agreement between the purchaser and the manufacturer.

NOTE Detailed information on the use of quality assurance is given in ISO standards (see [1], [2] and [3]). ISO 9001 is recommended as a guide for a quality system for manufacturing of insulators, considering 1.2 of ISO 9001.

7 General test procedures and requirements

The hollow insulator or hollow insulator body shall be subjected to the tests specified in Tables 2 or 3.

7.1 Verification of the dimensions and roughness of ground surfaces

The dimensions of all hollow insulators or hollow insulator bodies shall meet the values, including the permissible tolerances specified on the drawing. If not specified or unless otherwise agreed between the purchaser and the manufacturer, the following tolerances shall be applied.

7.1.1 General dimensional tolerances

Unless otherwise specified, the tolerance on each dimension shall be

$\pm (0,04 \times L_d + 1,5)$ mm when $L_d \leq 300$;

$\pm (0,025 \times L_d + 6)$ mm when $L_d > 300$,

where L_d is the checked dimension in millimetres (mm).

NOTE In many equipment designs the inner diameter, d_1 , is of importance. An example of such a tolerance $\pm(0,025 \times d_1 + 1,5)$ mm is suggested.

7.1.2 Creepage distance tolerance

The measurement of creepage distance shall be related to the design dimensions as specified on the insulator drawing, even though this dimension may be greater than originally specified by the purchaser.

The creepage distance shall be subject to the following tolerances:

- when the creepage distance is specified as a nominal value, the following negative tolerance will apply:
 $(0,04 \times L_c + 1,5)$ mm, where L_c is the nominal creepage distance;
- when the creepage distance is specified as a minimum value, it shall be considered as the minimum value obtained in measurements on the insulators.

NOTE The value of the creepage distance can affect the behaviour of the insulators in the electrical type tests. Therefore, the measured value of the creepage distance of the insulators submitted to the type tests should not exceed a maximum value of $1,04 \times L_c$.

7.1.3 Tolerance of wall thickness

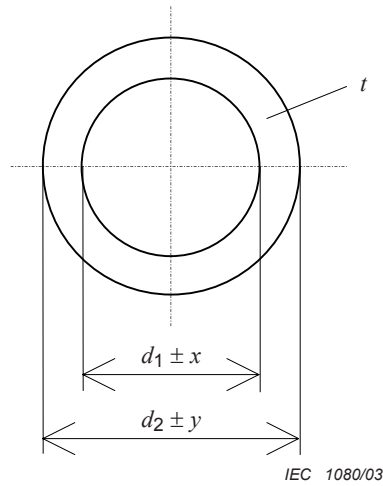

Nominal wall thickness t mm	Tolerance on wall thickness mm
$t < 10$	$+a / -1,5$
$10 \leq t < 15$	$+a / -2,0$
$15 \leq t < 20$	$+a / -3,0$
$20 \leq t < 25$	$+a / -3,5$
$25 \leq t < 30$	$+a / -4,0$
$30 \leq t < 40$	$+a / -4,5$
$40 \leq t < 55$	$+a / -5,0$
$55 \leq t < 70$	$+a / -6,0$

NOTE 1 These tolerances are not applicable to ground wall.

NOTE 2 Tolerance a is determined by the following equation: $a = \frac{x + y}{2}$

x and y are tolerances on diameter d_1 and d_2 .

NOTE 3 Nominal wall thickness $t = \frac{d_2 - d_1}{2}$

Figure 2 – Tolerance of wall thickness

7.1.4 Deviation from roundness of inner or outer core diameter

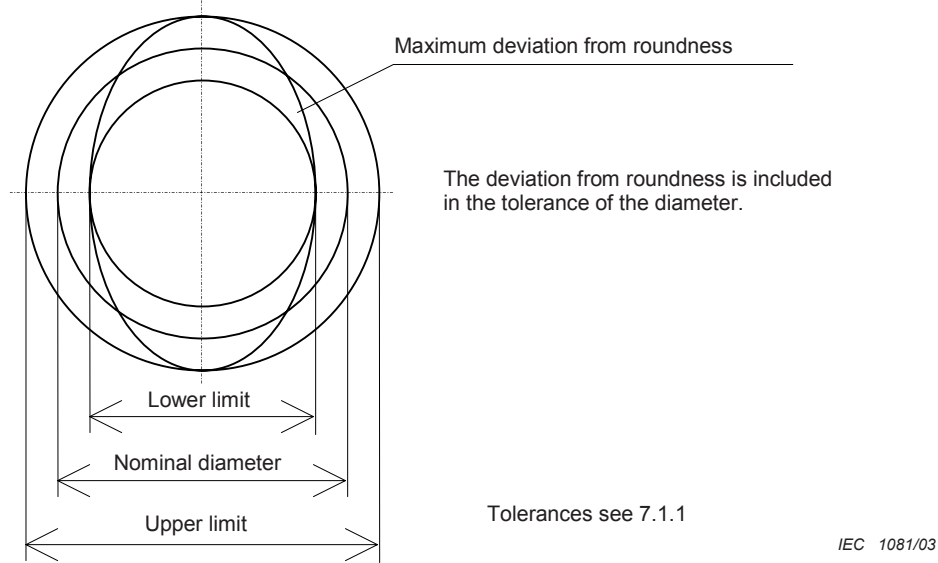

Figure 3 – Deviation from roundness of inner or outer core diameter

7.1.5 Camber

The camber δ of a hollow insulator body shall not be greater than

- $(0,006 \times h + 1)$ mm when $\frac{h}{d_1} \leq 8$
- $0,008 \times h$ mm when $\frac{h}{d_1} > 8$

where

h is the height of the hollow insulator in millimetres (mm);

d_1 is the greatest inner core diameter of the hollow insulator in millimetres (mm).

NOTE A suitable indirect method for measuring camber is indicated in Clause A.4 (Figure A.3).

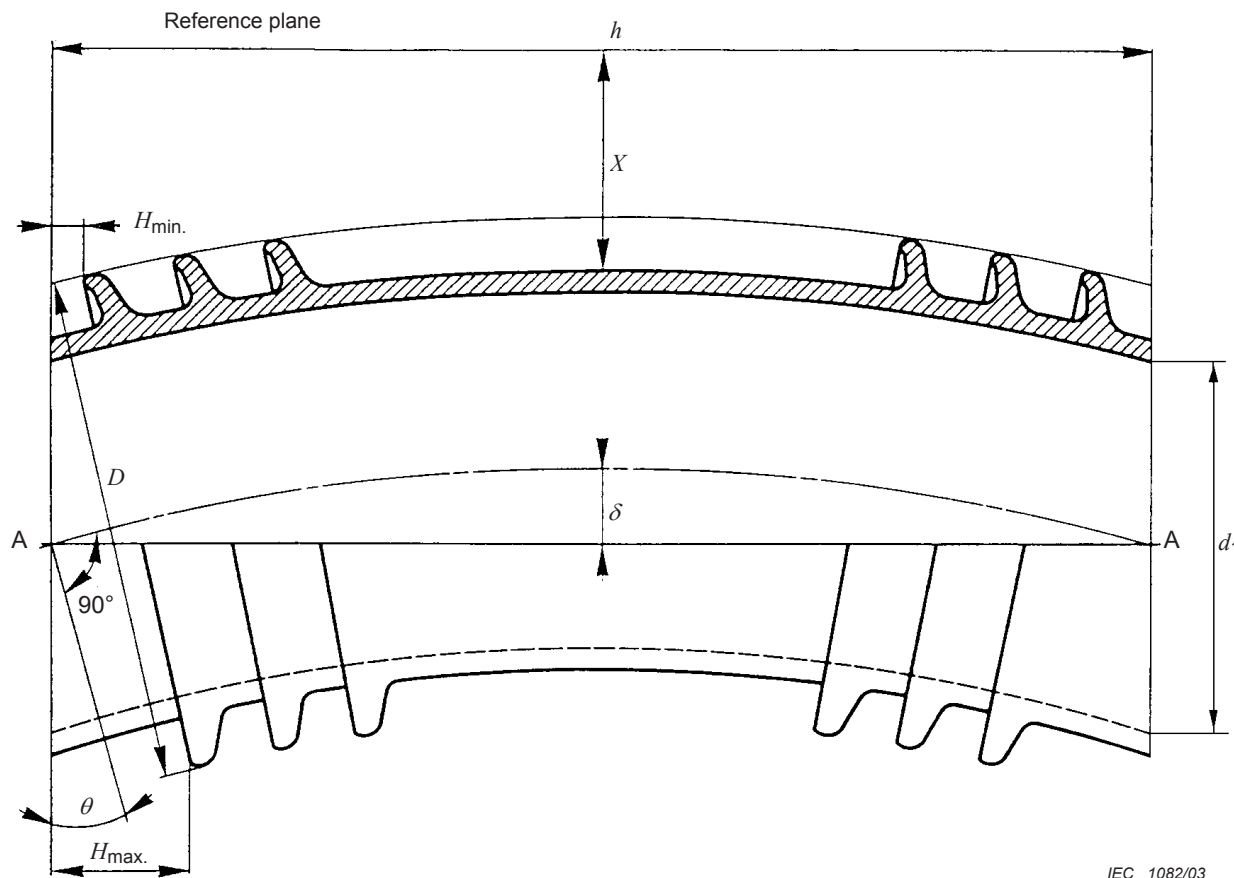

Figure 4 – Effect of camber of the hollow insulator body

7.1.6 Position of end shed

Due to the camber of the hollow insulator body there may be a shed inclination at the ends of the porcelain. The maximum camber of $0,6 \% \frac{h}{d_1} \leq 8$ or $0,8 \% \frac{h}{d_1} > 8$ of insulator length will give an angle θ according to Figure 4 which might be up to $0,024$ radians $\frac{h}{d_1} \leq 8$ or $0,032$ radians $\frac{h}{d_1} > 8$. Thus, the sheds at the ends of the insulator may be inclined at this angle. The distance H between the end shed and the ground face of the insulator will vary around the periphery. The minimum allowable dimension H may be shown on the drawing.

To verify the dimension H , H_{\max} and H_{\min} shall be measured. The position of the end shed complies with the drawing if the average value of

$$H = 0,5 \times (H_{\max} + H_{\min})$$

is within the general tolerances given in 7.1.1 or any special tolerances on dimension H given on the drawing.

The maximum inclination of end shed shall be such that

$$H_{\max} - H_{\min} < (0,024 \times D + 3) \text{ mm} \quad \text{when } \frac{h}{d_1} \leq 8$$

$$H_{\max} - H_{\min} < (0,032 \times D + 3) \text{ mm} \quad \text{when } \frac{h}{d_1} > 8$$

where

D is the nominal diameter of the end shed expressed in millimetres (mm);

H , H_{\max} and H_{\min} are defined according to Figure 4 and are nominal, maximum and minimum distances between end shed and the ground surface in millimetres (mm).

7.1.7 Tolerance on height of sanding and porcelain chamfered end flange

The height T of sanding and porcelain end flange will vary around the periphery.

The maximum variation in the height of both the sanding and porcelain end flanges shall be as follows (see Figure 5):

$$T_{\max} - T_{\min} < (0,024 \times d_3 + 3) \text{ mm} \quad \text{when } \frac{h}{d_1} \leq 8$$

$$T_{\max} - T_{\min} < (0,032 \times d_3 + 3) \text{ mm} \quad \text{when } \frac{h}{d_1} > 8$$

where

d_3 is the nominal diameter in millimetres (mm) of the porcelain end flange or the nominal diameter over sanding;

T , T_{\max} and T_{\min} are the nominal, maximum and minimum heights in millimetres (mm) of porcelain end flange or sanding around the periphery.

In certain designs of porcelain, chamfered end flange closer tolerances are needed and they shall then be specified on the drawing.

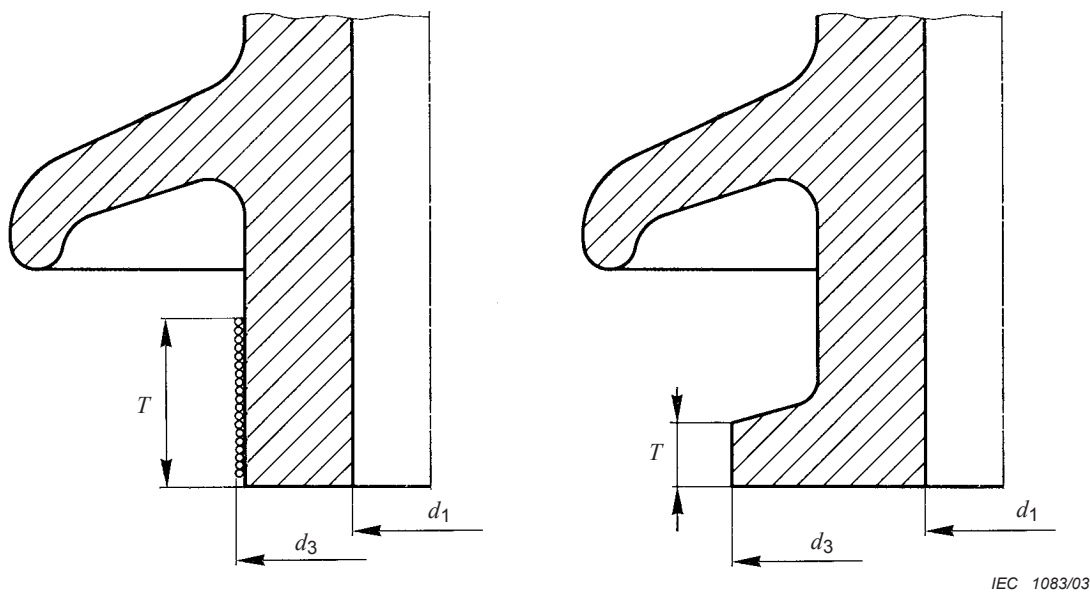

Figure 5 – Tolerance on height of sanding and porcelain chamfered end flange

7.1.8 Shed angle

The mean angle of slope of the upper surface of the sheds on the hollow insulator or hollow insulator body shall be measured when the design drawing shows a straight line connecting the radii at the inner and outer ends of the shed. The mean angle of a slope shall be subject to a tolerance of $\pm 3^\circ$.

Measurements shall be made in four mutually perpendicular directions on three sheds, located approximately at the top, middle, and bottom of the hollow insulator or hollow insulator body.

The mean value of the 12 measurements shall be calculated and compared with the value specified on the drawing.

NOTE 1 A suitable method for measuring shed angle is indicated in Clause A.5.

NOTE 2 When the design drawing shows the upper surface of the sheds as curved, it is not possible to measure the shed angle.

7.1.9 Tolerances on parallelism of end faces, coaxiality, eccentricity and angular deviation of fixing holes

All hollow insulators and hollow insulator bodies shall meet the tolerances on parallelism of end faces, coaxiality, eccentricity and angular deviation of fixing holes specified on the drawing, if any.

- Parallelism of end faces: examples of tolerance values are given in Clause A.1.
- Coaxiality and eccentricity: examples of tolerance values are given in Clause A.2.
- Angular deviation of fixing holes: examples of tolerance values are given in Clause A.3.

Examples of methods for measurements are given in Annex A.

7.1.10 Control of the roughness of ground surfaces

The roughness shall be specified in the relevant drawing as R_a or R_t value (see note) (refer to ISO 4287).

The ground surfaces at the ends of the hollow insulator bodies shall be controlled by a calibrated "roughness tester" at the location shown on the drawing.

The insulator passes the test if none of the measured values of R_a or R_t exceed the specified values for the roughness or the profile.

NOTE Due to the special properties of the ceramic materials, the correlation of R_a and R_t used for metals is not applicable. The proportion of R_a to R_t for ceramics is in the range of approximately 1 to 10.

7.1.11 Acceptance criteria

The hollow insulator or hollow insulator body passes the test if the measured roughness or dimensions meet the specified requirements, including permitted tolerances.

7.2 Mechanical failing load tests

Mechanical failing load tests are intended to determine the strength of a hollow insulator or hollow insulator body when subjected to mechanical loads for example pressure, bending, torsion, tension or compression. The mechanical failing load tests shall be carried out after the temperature cycle test.

The test for the mechanical strength of a hollow insulator or hollow insulator body shall consist of one or more of the following five tests as specified by the equipment manufacturer:

- pressure test;
- bending test;
- tensile test;
- torsion test;
- compression test.

A hollow insulator or hollow insulator body, which has been tested to its specified mechanical failing load, shall not subsequently be used in service.

7.2.1 General requirements for pressure tests

7.2.1.1 Hollow insulator

Plates, with suitably connected valve and gauge, shall be clamped or fixed to the fittings of the hollow insulator, with appropriate sealing gaskets interposed between the plates and the insulator body.

The sealing geometry shall be as close as possible to the intended application.

7.2.1.2 Hollow insulator body

In the case of a hollow insulator body, the plates may be fixed by a centre rod or held at the relevant distance by an external structure.

Tests performed on hollow insulator bodies are valid only when bodies are intended to be used in an assembly which is held together by longitudinal compression.

7.2.1.3 Pressure test procedure

The hollow insulator or hollow insulator body shall be completely filled with water and connected to a hydraulic pump. The hydraulic pressure is increased steadily at such a rate that the specified test pressure is reached without producing shock.

NOTE The rate of increase of the pressure per minute should be between 30 % and 60 % of the test pressure.

7.2.1.4 Acceptance criteria for pressure test

After releasing the pressure to zero, the insulator shall be examined for cracks in the porcelain or fittings, failures in the cementing or leaks. Where there is no evidence of the above, the test is considered satisfactory provided the fittings have not failed even though they may have been stressed beyond their yield point.

In case of doubt, an additional pressure test at the design pressure shall be performed.

7.2.2 General requirements for bending tests

Mounting for test for hollow insulator and hollow insulator body.

Bending tests may be carried out without internal pressure. The hollow insulator shall be attached to the mounting face of the testing machine by its normal method of mounting. The load shall be applied to the free end of the hollow insulator. The direction of loading shall pass through the axis of the hollow insulator and shall be at right angles to it.

Alternatively, by agreement between the purchaser and the manufacturer the mechanical bending test shall be carried out on the hollow insulator body. Suitable methods for testing the unassembled hollow insulator bodies are indicated in Annex B.

7.2.2.1 Bending test procedure

- Tests on a hollow insulator consisting of more than one unit:

where a hollow insulator consists of more than one unit and where bending moments are specified for the top and bottom of the complete hollow insulator, the complete insulator may be tested. An extension piece shall be attached to the hollow insulator and the load shall be applied at appropriate height to produce the test bending moments.

In case each individual unit has bending moments specified for both ends, the test is carried out as follows.

- Tests on an individual hollow insulator unit:

where bending moments are specified for the top and bottom of a hollow insulator, an extension piece shall be attached to the hollow insulator and the load shall be applied at appropriate height to produce the test bending moments.

- Test on an individual symmetrical hollow insulator unit:

if the hollow insulator is symmetrical, the unit can be tested by direct application at the free end of the insulator with an equivalent load to produce the prescribed bending moment. Such tests shall be performed once at each end.

7.2.2.2 Acceptance criteria for bending test

After releasing the moment to zero, the insulators shall be examined for cracks in the porcelain, failures of the cementing or cracks in the fittings. Where there is no evidence of the above, the test is considered satisfactory provided the fittings have not failed even though they may have been stressed beyond their yield point.

7.2.3 Torsion test

The hollow insulator shall be subjected to a torsional load, avoiding any bending moment. The torsional strength of hollow insulator may be determined by a test on a single hollow insulator unit (of the lowest strength type, if the hollow insulator comprises more than one type).

7.2.4 Tensile test

The hollow insulator shall be subjected to a tensile load along its axis. The tensile strength of a hollow insulator may be determined by a test on a single hollow insulator unit (of the lowest strength type, if the hollow insulator comprises more than one type).

7.2.5 Compression test

The hollow insulator or hollow insulator body shall be subjected to a compressive load along its axis. The compressive strength of a hollow insulator may be determined by a test on a single hollow insulator unit (of the lower strength type, if the hollow insulator comprises more than one type). Longer hollow insulators (which may fail by buckling) may need a test on a complete hollow insulator.

7.2.6 Acceptance criteria for torsion, tensile and compression tests

After releasing the loads to zero, the insulators shall be examined for cracks in the porcelain, failures of the cementing or cracks in the fittings. Where there is no evidence of the above, the test is considered satisfactory provided the fittings have not failed even though they may have been stressed beyond their yield point.

7.3 Temperature cycle test

7.3.1 General requirements

- The test shall be made on an individual hollow insulator or hollow insulator body prior to the mechanical failing load test, if any.
- The quantity of water in each test tank shall be sufficiently large for the immersion of the insulators not to cause a temperature variation of more than ± 5 K in the water.
- Intermediate containers may be used during the immersion of insulators in the hot or cold water bath; provided that they are in the form of a wire mesh basket having a low thermal mass, allowing free access for the water.

7.3.2 Test procedure for insulators of ceramic material and toughened glass

The insulators shall be quickly immersed in a water bath, maintained at a temperature t higher than that of the cold bath used later in the test, and left submerged for a minimum time duration of $(15 + 0,7 \times m)$ min and a maximum time duration of 30 min (m being the mass of the hollow insulator or hollow insulator body in kilograms (kg)). They shall then be removed and quickly and completely immersed in the cold-water bath where they shall remain submerged for the same number of minutes.

This heating and cooling cycle shall be performed three times in succession. The time taken to transfer from either bath to the other shall be as short as possible.

The temperature difference t is given in Table 5 as a function of the dimensions of the hollow insulator or hollow insulator body. This temperature difference may be marked on the drawing.

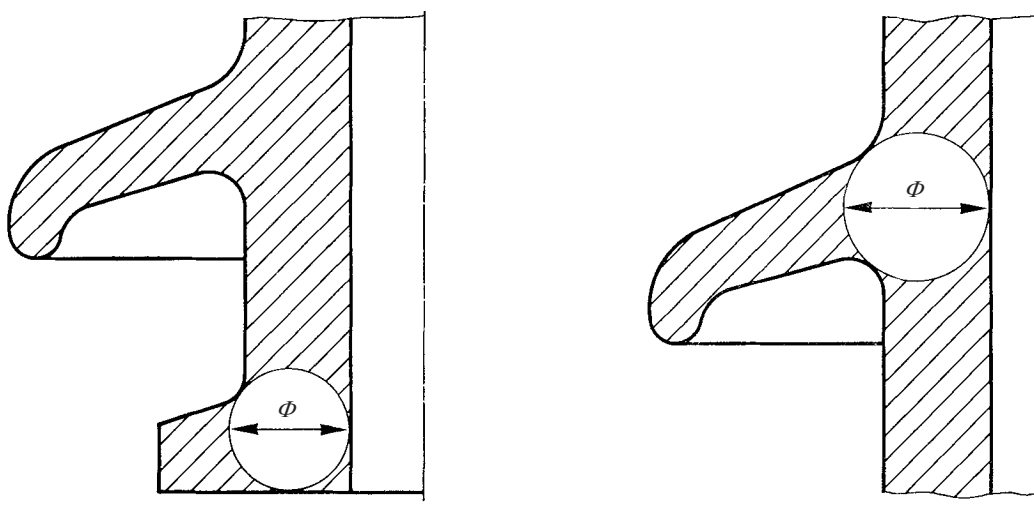

IEC 1084/03

Figure 6 – Definition of thickness Φ mm for temperature-cycle test

Table 5 – Selection of temperature difference for temperature cycle test

$D^2 \times h \times 10^{-6}$ mm ³	Temperature difference t for thickness ϕ mm					
	$\phi \leq 23$	$23 < \phi \leq 26$	$26 < \phi \leq 32$	$32 < \phi \leq 36$	$36 < \phi \leq 43$	$43 < \phi$
$D^2 \times h \leq 164$	60	55	50	45	40	35
$164 > D^2 \times h \leq 410$	55	55	50	45	40	35
$410 < D^2 \times h \leq 655$	50	50	50	45	40	35
$655 < D^2 \times h \leq 900$	45	45	45	45	40	35
$900 < D^2 \times h \leq 1150$	40	40	40	40	40	35
$1150 < D^2 \times h \leq 2\ 000$	35	35	35	35	35	35
$D^2 \times h > 2\ 000$	Subject to agreement between manufacturer and purchaser					

D is the greatest external diameter over the sheds of the hollow insulator or hollow insulator body, expressed in millimetres.

h is the height of the hollow insulator body, expressed in millimetres.

ϕ is the greatest thickness of material defined as the diameter, expressed in millimetres, of the largest circle which can be inscribed in the outline of a section through the axis of the hollow insulator or hollow insulator body.

The temperature differences in Table 5 apply to insulators of parallel or tapered internal shape which allow free access of water to the interior on immersion. Insulators are considered not to offer free access of water if the smallest internal diameter is less than 0,25 times the largest internal diameter. In such case, the value of t shall be agreed between purchaser and manufacturer.

7.3.3 Alternative test procedure for large insulators of ceramic material

Alternatively, whether size of the insulator precludes the use of the immersion technique according to 7.3.2, the water spraying method according to Figure C.1 may be applied. The hollow insulators with integral metal fittings, if any, shall be enveloped by a thick cloth case which is tied at the top by, for example, strings. Hot or cold water is poured or pumped into the case through hoses which are arranged for adequate water spraying of the hollow insulator. The water can be drawn off the case by a pump.

The temperature of the hollow insulator shall be raised by water spraying to a value t higher than that of the cold water which is later used to spray it with artificial rain. This temperature shall be maintained for 15 min.

The hollow insulator shall then be immediately sprayed with artificial rain at an intensity of about 3 mm/min and this spraying shall continue for 15 min.

The heating and cooling cycle shall be performed three times in succession. The temperature difference t is given in Table 6.

Table 6 – Selection of temperature difference for the alternative temperature-cycle test

Temperature difference t for thickness ϕ mm (as defined in Figure 6)	
$\phi \leq 30$	$\phi > 30$
70	50

7.3.4 Test procedure for insulators of annealed glass

Insulators composed of annealed glass shall be quickly and completely immersed, without being placed in an intermediate container, in a water bath maintained at a temperature t higher than that of the artificial rain which is used later in the test and left submerged for a period of 15 min in this bath. They shall then be withdrawn and quickly exposed for 15 min to artificial rain of intensity 3 mm/min, without any other specified characteristics.

The heating and cooling cycle shall be performed three times in succession. The time taken to transfer from the hot bath to the rain, or inversely, shall not exceed 1 min.

The ability of annealed glass to withstand a change of temperature is dependent on a number of factors, one of the most important being its composition. For these insulators, unless otherwise agreed between the purchaser and the manufacturer, the temperature difference t is given in Table 7.

Table 7 – Selection of temperature difference for insulators of annealed glass

Temperature difference t	
Soda lime glasses	Borosilicate glasses
30	70

7.3.5 Acceptance criteria

The insulator passes the test if there is no cracking or mechanical breakage or other faults causing deterioration in its electrical or mechanical properties. The absence of such deterioration is considered verified if the hollow insulator passes the electrical routine test, according to the procedure in 10.4.

An insulator which has successfully passed the temperature cycle test may be supplied with the rest of the batch for normal service.

7.4 Porosity test

The test is applicable only to ceramic insulators.

7.4.1 Test procedure

Ceramic fragments from the insulators or, by agreement, from representative pieces of ceramic fired adjacent to the insulators, shall be immersed in a 3 % solution of a red/violet Methin-dye (such as Astrazon or Basonil²) in methyl or ethyl alcohol under a pressure of not less than 15 MPa for a time such that the product of the test duration in hours and the pressure in MPa is not less than 180.

The fragments shall then be removed from the solution, washed, dried and again broken.

7.4.2 Acceptance criteria

Examination with the naked eye of the freshly broken surfaces shall not reveal any dye penetration. Penetration into small cracks formed during the initial breaking shall be ignored.

² Astrazon and Basonil are examples of suitable products available commercially. This information is given for the convenience of users of this International Standard and does not constitute an endorsement by IEC of these products.

7.5 Galvanizing test

Unless otherwise specified below, the following ISO standards are applicable for the performance of this test:

ISO 1460, ISO 1461, ISO 1463, ISO 2064, ISO 2178.

NOTE Although it is difficult to give a general recommendation, it is possible to repair satisfactorily the zinc coating on small areas damaged, for instance, by excessively rough treatment: the repair should be carried out by means of low-melting-point zinc-alloy repair rods made for this purpose. The thickness of the renovated coating should be at least equal to the thickness of the galvanized layer. The maximum size of the areas for which such a repair is acceptable will depend, to some extent, on the kind of ferrous part and the dimensions, but for general guidance, an area of 40 mm² is suggested as being suitable, 100 mm² being the maximum for large insulator fittings. Nevertheless, repair of the damaged coating is permitted only in exceptional cases of minor faults, after agreement between the purchaser and the manufacturer. It should be noted that repair by means of repair rods is possible only on loose ferrous parts, because the temperature of the ferrous part during this treatment will be too high to permit use of this method for assembled insulators.

7.5.1 Test procedure

The ferrous parts shall be subjected to the appearance test, followed by the determination of the coating mass using the magnetic test method. In case of difference of opinion about the results by the magnetic method, a decisive test shall be carried out

- either by the gravimetric method for castings and forgings and for washers by agreement. In this case the requirements of ISO 1460 are used;
- or by the microscopical method for bolts, nuts and washers. In this case the requirements of ISO 1463 are used.

NOTE By agreement between the purchaser and the manufacturer at the time of ordering, other test methods can be used, for instance, the test by immersion in copper sulphate solution or the gasometric method. The agreement should determine the choice of one method, its application, and the general testing conditions. There exist many bibliographic references to describe the test method for measuring the continuity of a zinc coating by immersion in copper sulphate solution.

7.5.1.1 Appearance

The ferrous parts shall be submitted to a visual inspection.

7.5.1.2 Determination of the coating mass by the magnetic test method

This test shall be made under the conditions prescribed in ISO 2178, in particular sections 4 and 5. These sections are very important in order to obtain accurate measurements.

On each sample to be tested, three to ten measurements shall be carried out, according to its dimensions. These measurements shall be uniformly and randomly distributed over the whole surface, avoiding edges and sharp points.

NOTE The determination of the coating mass by the magnetic method is non-destructive, simple, quick, sufficiently exact, and in most cases adequate. Therefore, this method is specified as the basic test.

7.5.2 Acceptance criteria

7.5.2.1 Acceptance criteria for the appearance test

The coating shall be continuous, as uniform and smooth as possible (in order to prevent injury during handling), and free from anything that is detrimental to the stated use of the coated object (see 6.1 of ISO 1461).

Small uncoated spots are permissible. The maximum area of an uncoated spot may be 4 mm²; but the whole uncoated surface shall be not more than

- 0,5 % of the approximate total surface of the ferrous metal part when the total surface is less than 4 000 mm²;
- 20 mm² when the total surface is between 4 000 mm² and 100 000 mm²;
- 0,02 % of the approximate total surface of the ferrous metal part when the total surface exceeds 100 000 mm², in which case the maximum area of an uncoated spot may be 7 mm².

The coating shall be sufficiently adherent to withstand handling consistent with normal use of the article without peeling or flaking.

NOTE Ferrous parts with screw threads are galvanized after threading. Nuts and tapped holes are tapped after galvanizing, unless otherwise agreed between the purchaser and the manufacturer. After tapping, the internal threads should be protected by an adequate coating of oil, grease, or other suitable product.

7.5.2.2 Acceptance criteria for the value of coating mass

The coating mass value given by the arithmetic average of measurements shall be not less than the minimum value specified below.

The following standard minimum values are applicable, unless the purchaser and manufacturer have agreed beforehand on higher values if the insulators are to be used in unusually severe conditions.

Minimum average coating mass:

- for iron and steel castings and forgings:
600 g/m² for all samples, with 500 g/m² on any individual sample;
- for bolts, nuts and washers:
375 g/m² for all samples, with 300 g/m² on any individual sample.

NOTE For guidance, the approximate thickness equivalent to the above values are

- 600 g/m² = 85 μm;
- 500 g/m² = 70 μm;
- 375 g/m² = 54 μm;
- 300 g/m² = 43 μm.

However, if the average value for all samples is satisfactory and if the average value of only one individual sample is not satisfactory, a retest is made by the same procedure as in 6.4. If the result for each individual sample is satisfactory, but the average value for the samples is not satisfactory, a decisive test shall be made by either the gravimetric or the microscopical method (see 7.5.1).

8 Type tests

8.1 Tests

The type tests are the following when specified on the relevant drawing:

- a) temperature cycle test (7.3); only when mechanical failing load tests are specified;
- b) pressure test (8.2);

- c) bending test (8.3);
- d) torsion, tension or compression tests (7.2.3, 7.2.4, 7.2.5); when specified on the relevant drawing.

8.2 Pressure test

The pressure test shall be performed under the conditions and acceptance criteria mentioned in 7.2.

8.2.1 Pressure test for hollow insulators or hollow insulator bodies intended for general use

The insulator shall withstand a test pressure which is higher than the design pressure for 5 min without failure. The test pressure is dependent on equipment design and shall be specified on the drawing.

8.2.2 Pressure test for ceramic hollow insulators or hollow insulator bodies intended for use with permanent gas pressure

The type test withstand pressure is dependent on equipment design and shall be specified on the drawing. The insulator shall withstand 4,25 times the design pressure for 5 min without failure. The design pressure shall be determined by the equipment manufacturer. Details for the determination of the design pressure are given in 5.2.

After satisfying the acceptance criteria (7.2.1.4) and to provide additional information, the pressure shall be increased until the mechanical failing load is reached. The value of the mechanical failing load shall be recorded in the type test and sample test certificates.

8.3 Bending test

The bending test shall be performed under the conditions and acceptance criteria mentioned in 7.2.

8.3.1 Bending test for hollow insulators or hollow insulator bodies intended for general use

Seventy per cent of the type test withstand bending moment shall be applied to the insulator in four directions at 90° to each other and shall be maintained for 10 s in each of the first three directions. On reaching this value in the fourth direction, the bending moment shall be increased to 100 % of the type test withstand bending moment in a further 30 s to 90 s and shall be maintained for 1 min.

8.3.2 Bending test for ceramic hollow insulators or hollow insulator bodies intended for use with permanent gas pressure

The type test withstand bending moment is dependent on equipment design and shall be specified on the drawing. The withstand bending moment shall be determined by the equipment manufacturer. Details for the determination of the design bending load are given in 5.2.

Seventy per cent of the type test withstand bending moment shall be applied to the insulator in four directions at 90° to each other and shall be maintained for 10 s in each of the first three directions. On reaching this value in the fourth direction, the bending moment shall be increased to 100 % of the type test withstand bending moment in a further 30 s to 90 s and shall be maintained for 1 min.

After satisfying the acceptance criteria (7.2.2.2) and to provide additional information, the bending moment shall be increased until the mechanical failing load is reached. The value of the mechanical failing moment shall be recorded in the type test and sample test certificates.

9 Sample tests

9.1 Tests for hollow insulators or hollow insulator bodies intended for general use

The test insulators shall be subjected to the following tests:

- a) verification of dimensions (7.1);
- b) control of the roughness of the ground parts (7.1);
- c) porosity test (7.4); applicable only to ceramic insulators;
- d) temperature cycle test (7.3);
- e) galvanizing test (7.5); for cast iron and malleable cast iron fittings;
- f) pressure test (8.2.1); when specified on the relevant drawing;
- g) bending test (8.3.1); when specified on the relevant drawing;
- h) torsion, tension or compression tests (7.2.3, 7.2.4, 7.2.5); when specified on the relevant drawing.

9.2 Tests for ceramic hollow insulators or hollow insulator bodies intended for use with permanent gas pressure

The test insulators shall be subjected to the following tests:

- a) verification of dimensions (7.1);
- b) control of the roughness of the ground parts (7.1);
- c) porosity test (7.4);
- d) temperature cycle test (7.3);
- e) galvanizing test (7.5); for cast iron and malleable cast iron fittings;
- f) pressure test (8.2.2);
- g) bending test (8.3.2);
- h) torsion, tension or compression tests (7.2.3, 7.2.4, 7.2.5); when specified on the relevant drawing.

10 Routine tests

10.1 Tests for hollow insulators or hollow insulator bodies intended for general use

The routine tests comprise:

- a) visual examination (10.3);
- b) electrical test (10.4);
- c) pressure test (10.5.1) when specified on the relevant drawing;
- d) bending tests (10.5.2) when specified on the relevant drawing;
- e) other mechanical tests (10.5.3) when specified on the relevant drawing;
- f) thermal shock test (10.7); applicable only to toughened glass insulators.

Additional tests such as verification of relevant dimensions (7.1) and mechanical tests (10.5) may be performed after agreement between manufacturer and purchaser.

10.2 Tests for ceramic hollow insulators or hollow insulator bodies intended for use with permanent gas pressure

The routine tests comprise

- a) visual examination (10.3);
- b) electrical test (10.4);
- c) pressure test (10.6.1);
- d) bending test (10.6.2);
- e) other mechanical tests (10.6.3) when specified on the relevant drawing.

Additional tests such as verification of relevant dimensions (7.1) and temperature cycle test (7.3) may be performed by agreement between manufacturer and purchaser.

10.3 Routine visual inspection

Each hollow insulator or hollow insulator body shall be examined. The mounting of the metallic fittings on the insulating parts shall be in accordance with the drawings.

10.3.1 Hollow insulators or hollow insulator bodies of ceramic material

10.3.1.1 Colour of glaze

The colour of the insulator shall correspond approximately to the colour specified on the drawing. Some variation in the shade of the glaze is permitted and shall not justify rejection of the insulator. This is valid also for areas where the glaze is thinner and therefore lighter, for example, on edges with small radii.

10.3.1.2 Surface appearance

The glazed and unglazed surfaces shall fulfil the following properties:

- the glaze shall be a smooth and shining hard glaze. The surfaces shall be free from cracks, scratches and without wrinkles, blisters, glaze inclusions or other defects prejudicial to satisfactory performance in service. These defects are treated as single glaze defects for evaluation of allowed size of defects;
- chipping of glaze at the border to ground or chamfered surfaces shall not be allowed;
- cement shall not remain on surfaces inside or outside the insulator.

External surfaces: any single glaze inclusion shall not protrude more than 2 mm, from the surface.

Internal surfaces:

- no sharp protrusions or depressions from the surface are allowed;
- smooth cavities or tool marks up to a depth of 2 mm are allowed.

10.3.1.3 Glaze defects

Glaze defects are spots without glaze, chips, inclusions in the glaze, and pinholes.

The total area of glaze defects on each insulator shall not exceed

$$100 + \frac{D \times L_c}{2000} \text{ mm}^2$$

For external surfaces:

$D = D_o$, where D_o is the greatest external diameter in millimetres (mm) of the insulator;

$L_c = L_{co}$, where L_{co} is the creepage distance in millimetres (mm) of the insulator.

For internal surfaces:

$D = D_i$, where D_i is the greatest internal diameter in millimetres (mm) of the insulator;

$L_c = L_{ci}$, where L_{ci} is the internal creepage distance in millimetres (mm) of the insulator.

The area of any single glaze defect shall not exceed

100 mm² for $D_o \times L_{co} \leq 30 \times 10^5$

200 mm² for $D_o \times L_{co} > 30 \times 10^5$

where D_o and L_{co} are as defined above.

On the inner and outer core of the insulator the single glaze defect shall not exceed 25 mm².

Very small pinholes, of a diameter less than 1,0 mm (for example, those caused by particles of dust during glazing) shall not be included in the total area of glaze defects. However, in any area 50 mm × 10 mm the number of pinholes shall not exceed 15. Furthermore, the total number of pinholes on the insulator shall not exceed

$$50 + \frac{D_o \times L_{co}}{1500}$$

where D_o and L_{co} are as defined above.

10.3.1.4 Cement joints

If a hollow insulator is equipped with metal end fittings cemented to the hollow insulator body the cemented joints shall fulfil the following properties:

- the cement filling of the joints shall be homogenous;
- the cement must not be easily removed or loosened during the routine test.

Radial hairline cracks, but not circumferential cracks, in the cement joint can be accepted.

10.3.2 Hollow insulators or hollow insulator bodies of glass material

The insulator shall exhibit no surface faults such as wrinkles or blisters liable to affect its behaviour in service. There shall be no bubble in the glass with a diameter greater than 5 mm. No single bubble or series of bubbles shall reduce the wall thickness by more than 25 %.

10.4 Electrical routine test

The electrical routine test is intended to verify the soundness of the wall of hollow insulator bodies.

Hollow insulator bodies made of sections joined with epoxy may be tested only at the joints provided that the individual pieces have been previously tested.

NOTE When a hollow insulator body does not contain any joints made before or after firing, for example, when it is manufactured solely by extrusion, the electrical routine test may be eliminated by agreement between manufacturer and purchaser.

10.4.1 Test procedure

The soundness of the wall of the hollow insulator body is checked between internal and external electrodes.

An alternating voltage with a frequency in the range of 15 Hz to 100 Hz shall be applied between the internal and external electrodes. The applied voltage shall not be less than 1,5 kV r.m.s. per mm of wall thickness of the hollow insulator body at its thinnest point with a minimum of 35 kV r.m.s. This voltage shall be maintained for 5 min.

For small hollow insulator bodies, the minimum voltage 35 kV may not always be applicable because of flashover. In such cases, the highest practical voltage shall be applied.

NOTE 1 Typical examples of internal electrodes are

- water filling the hollow insulator body, one end of which has been closed;
- a conductor applied to the internal profile.

NOTE 2 Typical examples of external electrodes are

- chains;
- wires

placed on the external core diameter as considered necessary and particularly at any joints made during manufacture.

10.4.2 Acceptance criteria

All hollow insulator bodies which do not puncture during the test are accepted.

10.5 Routine mechanical tests for hollow insulators or hollow insulator bodies intended for general use

Depending on the service application of the hollow insulator or hollow insulator body and its design, it may be necessary to perform mechanical routine tests. In such a case the mechanical routine test shall be specified on the drawing.

10.5.1 Routine pressure test

If applicable the hollow insulator or hollow insulator body shall be tested according to the general requirements of 7.2. In such a case each insulator shall be tested at a routine test pressure which is higher than the design pressure for 1 min. The test pressure is dependent on equipment design and shall be specified on the drawing. The test pressure shall, if required, be marked on the ground surface of the insulator body (outside the intended sealing area) or by stamping on the metal fitting if applicable.

10.5.2 Routine bending test

10.5.2.1 Hollow insulators

If applicable, the hollow insulator shall be tested according to the general requirements of 7.2. In such a case each hollow insulator shall be tested to the routine bending moment in four mutually perpendicular directions, each for 10 s. The value of the routine bending moment shall be 50 % of the withstand bending moment.

Alternatively, by agreement between purchaser and the manufacturer at the time of ordering, a bending test with a load up to 70 % of the specified mechanical failing load may be applied in more than one direction, each for 10 s.

10.5.2.2 Hollow insulator bodies

As an alternative to a routine bending test on a hollow insulator, the routine bending test may, by agreement between the purchaser and the manufacturer, be made on the hollow insulator body.

In this case, bending loads shall be applied in four mutually perpendicular directions. They shall be of sufficient magnitude to ensure that the bending stress achieved at each position along the free or unsupported length of the hollow insulating part is equivalent to at least 70 % and not exceeding 100 % of the stress at that position corresponding to the withstand bending moment.

NOTE 1 Suitable methods for routine bending tests of hollow insulator bodies are indicated in Annex B.

NOTE 2 It should be noted that this test does not verify the metal fittings or the hollow insulator.

10.5.3 Routine mechanical test determined by service applications

When required by service applications, the purchaser and the manufacturer may agree to a different form of routine test, for example, a torsion test, tensile test or a compressive test. The details shall be agreed at the time of placing the order.

10.5.4 Acceptance criteria

After the mechanical routine test, visual examination of the hollow insulator or hollow insulator body shall confirm the absence of damage.

10.6 Routine mechanical tests for ceramic hollow insulators or hollow insulator bodies intended for use with permanent gas pressure

Routine pressure and bending tests are compulsory for ceramic hollow insulators or hollow insulator bodies intended for use with permanent gas pressure. The mechanical routine test shall be specified on the drawing.

10.6.1 Routine pressure test

In accordance with the general requirements of pressure testing (7.2) each hollow insulator shall be tested at a test pressure of three times the design pressure for 1 min.

For routine tests of hollow insulator bodies, each shall be tested at a test pressure of 4,25 times the design pressure for 1 min.

The test pressure shall be marked on the ground surface of the insulator body (outside the intended sealing area) or by stamping on the metal fittings.

For hollow insulator units or hollow post insulator units, the routine pressure test may be omitted if it can be demonstrated that the stresses due to the design pressure are small compared to the stresses due to the maximum permanent bending moment in service (see Annex D).

10.6.2 Routine bending test

The hollow insulator shall be tested with the routine bending moment in four directions and in accordance with the general requirements for bending tests (7.2). The value shall be 70 % of the type-test withstand bending moment and shall be maintained for 10 s in each direction.

The routine bending test may be omitted for the hollow insulators for which it can be demonstrated that the stresses due to the maximum permanent bending moment in service are small compared to the stresses due to the design pressure (see Annex D).

The test method shall be agreed between manufacturer and purchaser. Insulators having passed the routine bending moment test shall suitably be marked on a ground surface of the insulator or by stamping on the metal fittings.

NOTE Tests on hollow insulator bodies with higher loads are possible.

10.6.3 Routine mechanical test determined by service applications

When required by service applications, the purchaser and the manufacturer may agree to a different form of routine test, for example, a torsion test, tensile test or a compressive test. The details shall be agreed at the time of placing the order.

10.6.4 Acceptance criteria

After the mechanical routine test, visual examination of the hollow insulator or hollow insulator body shall confirm the absence of damage.

10.7 Routine thermal shock test

The toughened glass parts, before assembly or mounting of metal fittings, shall be quickly and completely immersed in water at a temperature not exceeding 50 °C, after having been heated by hot air or other suitable means, to a uniform temperature at least 100 K higher than that of the water.

Toughened glass parts which break during this test shall be rejected.

11 Documentation

11.1 Marking

Each hollow insulator body shall be marked, on an external glazed surface or glass surface, with the name or trademark of the manufacturer and the year of manufacture. The part number and serial number markings are compulsory for ceramic hollow insulator bodies intended for use with permanent gas pressure. These markings shall be legible and indelible.

11.2 Records

The manufacturer shall maintain records of all hollow insulators or hollow insulator bodies produced in accordance with this standard for a minimum of 10 years. These records shall contain the following information:

- part number if required (11.1);
- serial number if required (11.1);
- date of manufacture;
- type test, date and results;
- sample tests, date and results;
- routine tests, date and results.

The purchaser shall be provided with records upon request.

Annex A (informative)

Methods of testing for tolerances of parallelism, coaxiality, eccentricity, angular deviation, camber and shed angle of hollow insulators or hollow insulator bodies

Methods of testing for tolerances of form and position are only given as examples. Other adequate test methods may also be used. Typical values for tolerances are given.

A.1 Parallelism of the end faces

See Figure A.1.

- For $h \leq 1$ m, $p \leq 0,5$ mm.
- For $h > 1$ m, $p \leq 0,5 \times h$ mm with h in metres (m).

The tolerances of the parallelism are related to a diameter of 250 mm.

Measuring of parallelism:

The hollow insulator or hollow insulator body is mounted upright and centrally on a rigid turntable, for example, by using conical shank screws and an intermediate flat plate of uniform thickness, if necessary. On the top face of the insulator, a plate of uniform thickness is fixed either centrally for hollow insulator bodies or conical shank screws for hollow insulators. The measuring device A is read as the insulator is rotated on the turntable, and the maximum and minimum values noted. The difference between these values, related to a circle of 250 mm in diameter, is the error of the parallelism of the end faces of the insulator.

A.2 Coaxiality and eccentricity

See Figure A.1.

Measuring of coaxiality applies to hollow insulators only.

Coaxiality: $c = 2 \times e$

Eccentricity: $e \leq 2(1+h)$ mm with h in metres (m).

Measuring of coaxiality and eccentricity:

Using the same method of mounting, a circular plate is fixed concentrically with the fixing holes in the top surface, for example, by using conical shank screws. The measuring device B is read as the insulator is rotated on the turntable, and the maximum and the minimum values noted. The eccentricity is considered to be half the difference between these values.

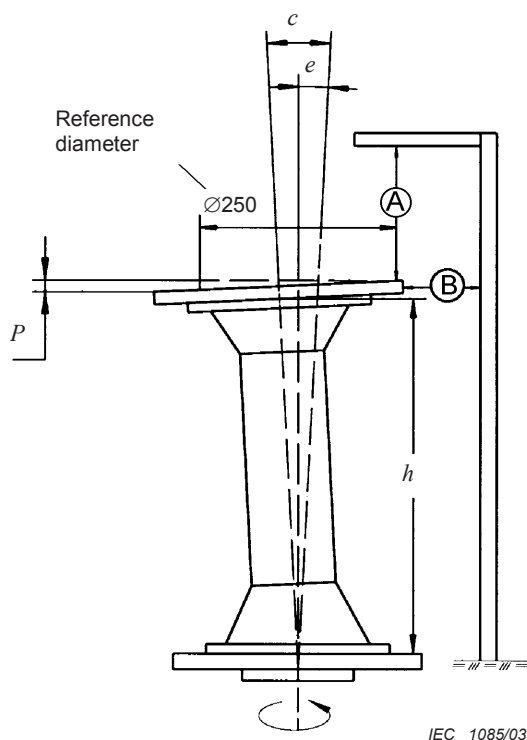

Figure A.1 – Measuring of tolerances of form and position

A.3 Angular deviation of fixing holes

Tolerance of the deviation: $-1^\circ \leq \alpha \leq +1^\circ$.

Measuring of angular deviation of fixing holes (see Figure A.2):

The hollow insulator is mounted horizontally, for example using V-blocks at each end. Screws, having accurately machined plain shanks, shall be screwed into the tapped holes in the end fittings. In case the end fitting has plain holes, the shank bolts shall be used.

Using an accurate spirit level at one end, and a direct reading spirit level at the other end, the relative angular position of the fixing holes shall be determined as shown.

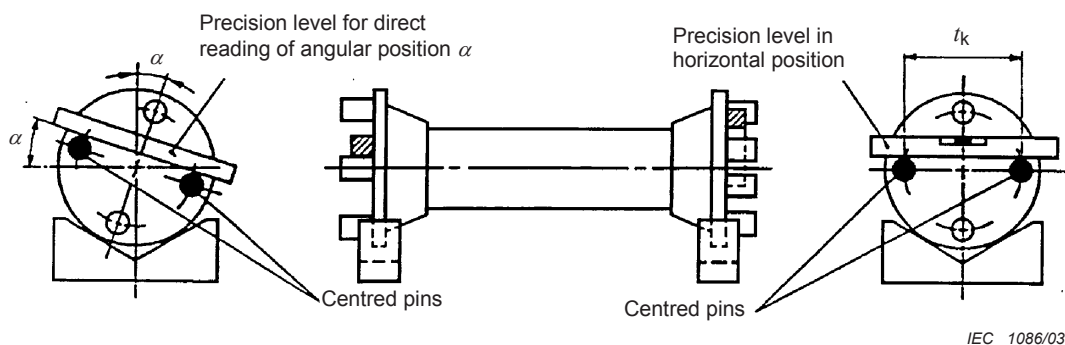

Figure A.2 – Measuring of angular deviation of fixing holes

A.4 Camber

The hollow insulator or hollow insulator body is mounted in such a way that it can be rotated about an axis passing through the centres of the inner diameters of the end faces or as close as possible to these centres. The insulator is then rotated through a complete revolution and the distance from outer surface of the wall to a reference plane parallel to the axis of rotation is measured. The difference $X_{\max} - X_{\min}$ resulting from rotation of 180° is determined (see Figure 4).

The camber is then given by the maximum value of $0,5 \times (X_{\max} - X_{\min})$.

The measuring device is then positioned at various levels along the reference axis and read as the insulator is rotated on the turntable, and the difference between maximum and minimum values noted at each level.

Alternatively, the camber can be checked by internal gauges.

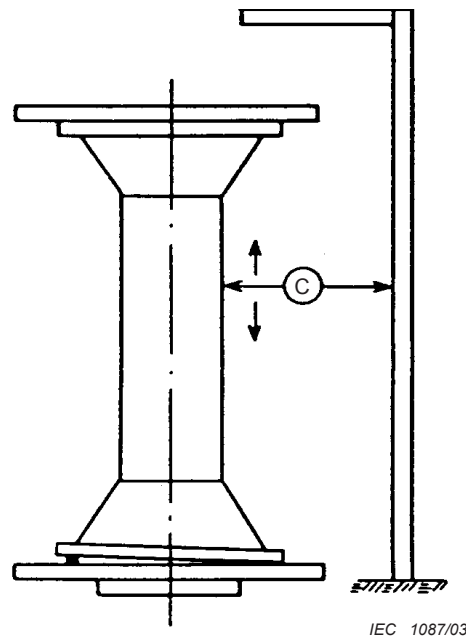

Figure A.3 – Method for measuring camber

A.5 Shed angle

The hollow insulator or hollow insulator body is mounted vertically so that it can be rotated. This can be done by using the same method of mounting as that described in Figure A.1.

Alongside the insulator, a vertical member carries a measuring device D which incorporates a horizontal reference mark and a moveable piece with angular graduations. When the edge of the moveable piece is aligned to the upper surface of the shed, the slope or shed angle may be determined from the angular graduation.

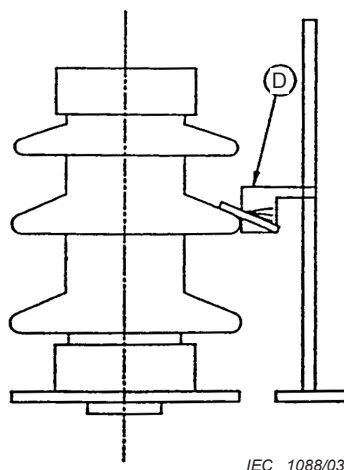

Figure A.4 – Measuring shed angle

A.6 Precautions to be taken during the tests

For the tests of Clauses A.1, A.2, A.4 and A.5 it is necessary to verify that the surface of the turntable is perpendicular to the rotation axis.

For the tests of Clauses A.1 and A.2 it is also necessary to take care that the pitch circle of the fixing holes of the hollow insulator metal fitting is correctly centred, with reference to the axis of rotation of the turntable. For this purpose, four fixing holes may be used, fitting them with conical shank screws or bolts (an example is given in Figure A.5).

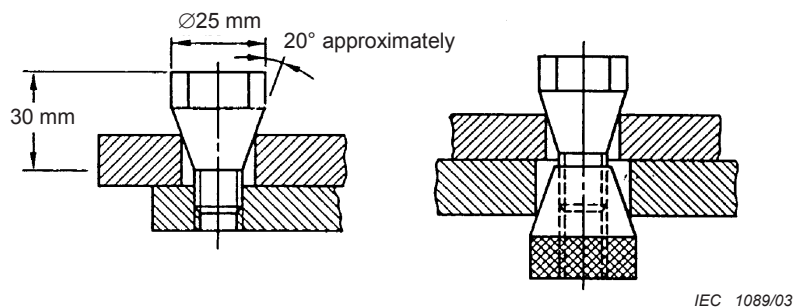
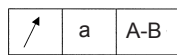
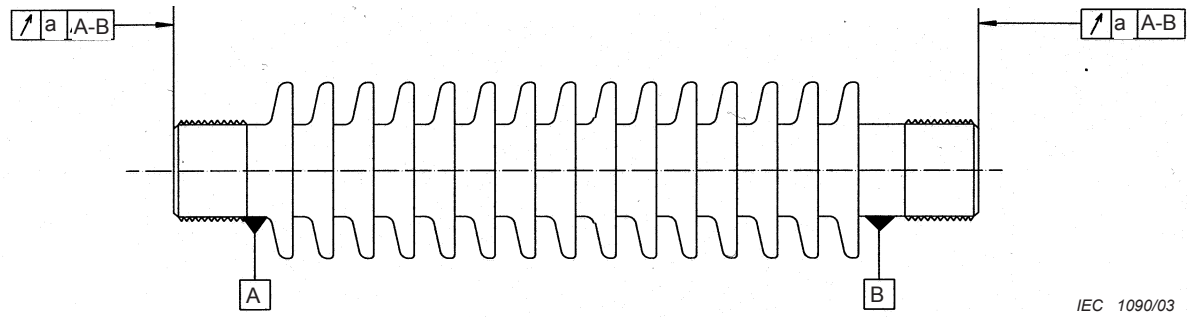

Figure A.5 – Centring with conical shank screws

A.7 Tolerances of form and position

See Figures A.6, A.7 and A.8.



Axial run-out: the numerical value indicates the maximum deviation of run-out around the points A and B.

Figure A.6 – Axial run-out

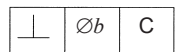
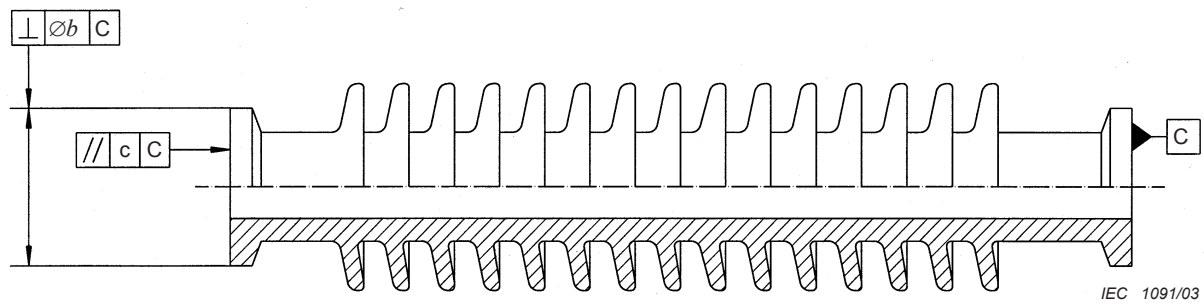

Perpendicularity: the axis of the insulator has to be within the indicated value of the diameter of the cylinder, which is perpendicular to the plane face C.

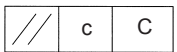

Parallelism: the upper face is parallel to the lower reference plane C within the indicated tolerances.

Figure A.7 – Parallelism and perpendicularity

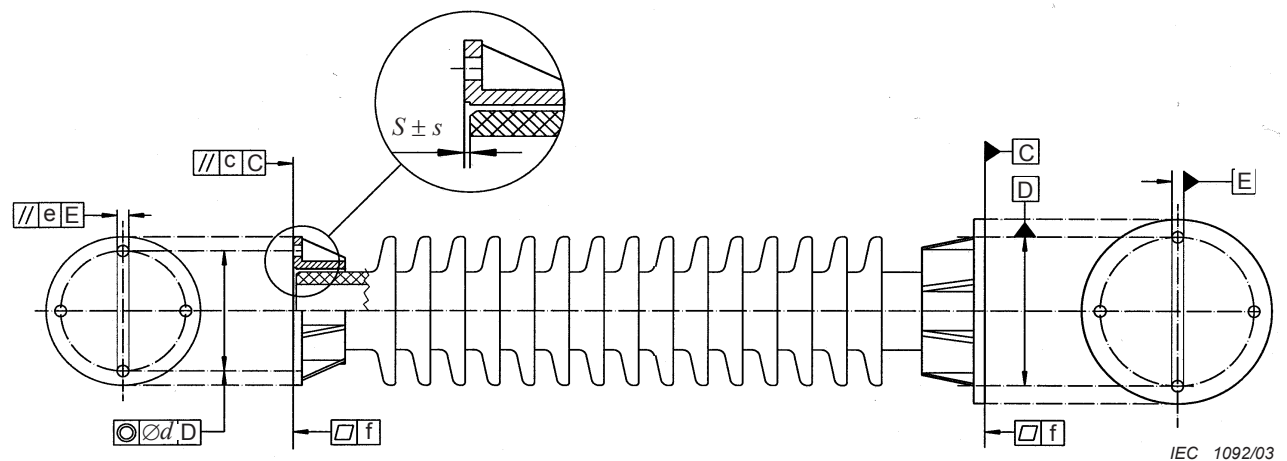

IEC 1092/03

- $\parallel c C$ Parallelism: the upper face is parallel to the lower reference plane C within the indicated tolerances.
- $\odot \varnothing d D$ Coaxiality and concentricity: the axis of the top fitting pitch circle diameter has to be within a cylinder with a diameter as indicated by the numerical value.
- f Evenness: the numerical value indicates the maximum admissible evenness of the face.
- $\parallel e E$ Alignment of the fixing holes: the line between two opposite axis of holes of the top fitting has to be in line with the corresponding line of the bottom fitting within two parallels of specified distance.
- $S \pm s$ For proper sealing, the end faces of the hollow insulator body have to be at a distance within specified tolerances from the faces of the fittings.

NOTE The small letter has to be replaced by the corresponding tolerance value.

Figure A.8 – Coaxiality and concentricity, evenness, alignment of fixing holes and proper sealing

Annex B
(informative)

Methods for bending tests of hollow insulator bodies

These test methods are only given as an example. Other adequate test methods may be used. The manufacturer should select the test method which most closely corresponds to the application of the specified loading conditions.

B.1 Test method with uniform bending moment

The hollow insulator body for test may be mounted horizontally in a suitable test equipment, such as that shown schematically in Figure B.1. The application of equal loads by means of the hydraulic rams results in a uniform bending moment being applied throughout the length of the hollow insulator body. By suitable adjustment of the positions of the loading and fulcrum points, and of the loads, this bending moment can be made equal to the bending moment on the unit when the hollow insulator is subject to the specified mechanical failing load. The bending moment shall be applied in four mutually perpendicular directions, the loads being released before the hollow insulator body is turned through 90°.

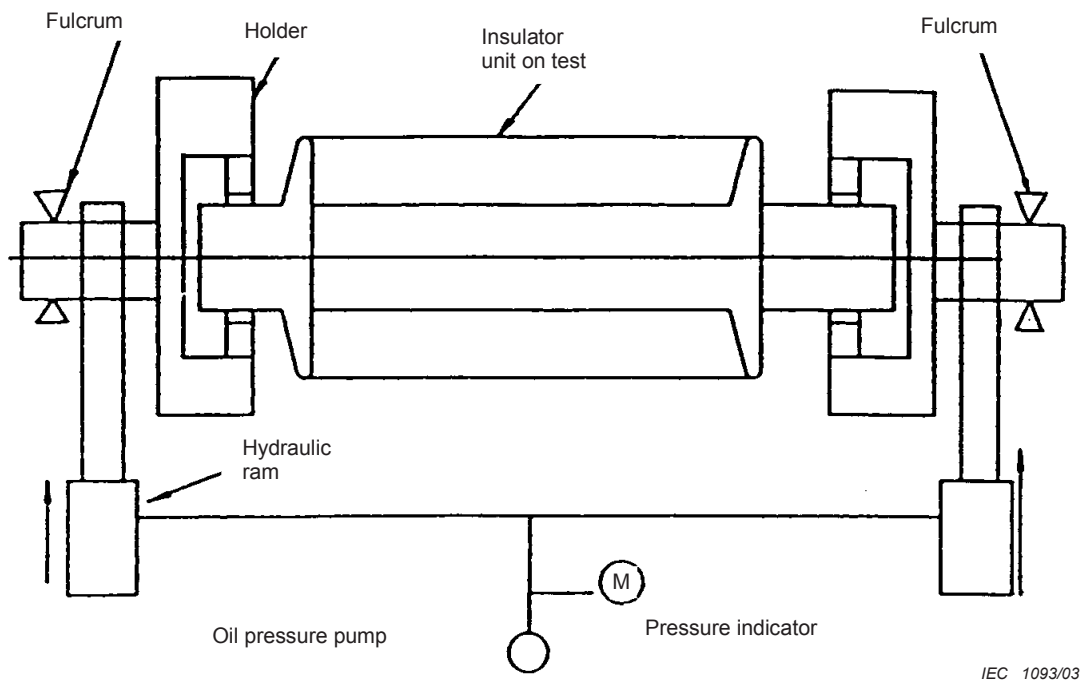

IEC 1093/03

Figure B.1 – Test ram for uniform distributed bending moment

B.2 Test method with non-uniform bending moment applied

The hollow insulator body for test may be mounted horizontally in a suitable test equipment, such as that shown schematically in Figure B.2. The application of a load by means of the hydraulic ram to the lever arms results in a non-uniform bending moment applied throughout the length of the hollow insulator body. By adjustment of the effective length of the lever arms of the load, the resulting bending moment diagram can have the same form as the bending moment diagram for the unit when the hollow insulator is subject to the specified mechanical failing load. The bending moment shall be applied in four mutually perpendicular directions, the load being released before the insulator unit is turned through 90°.

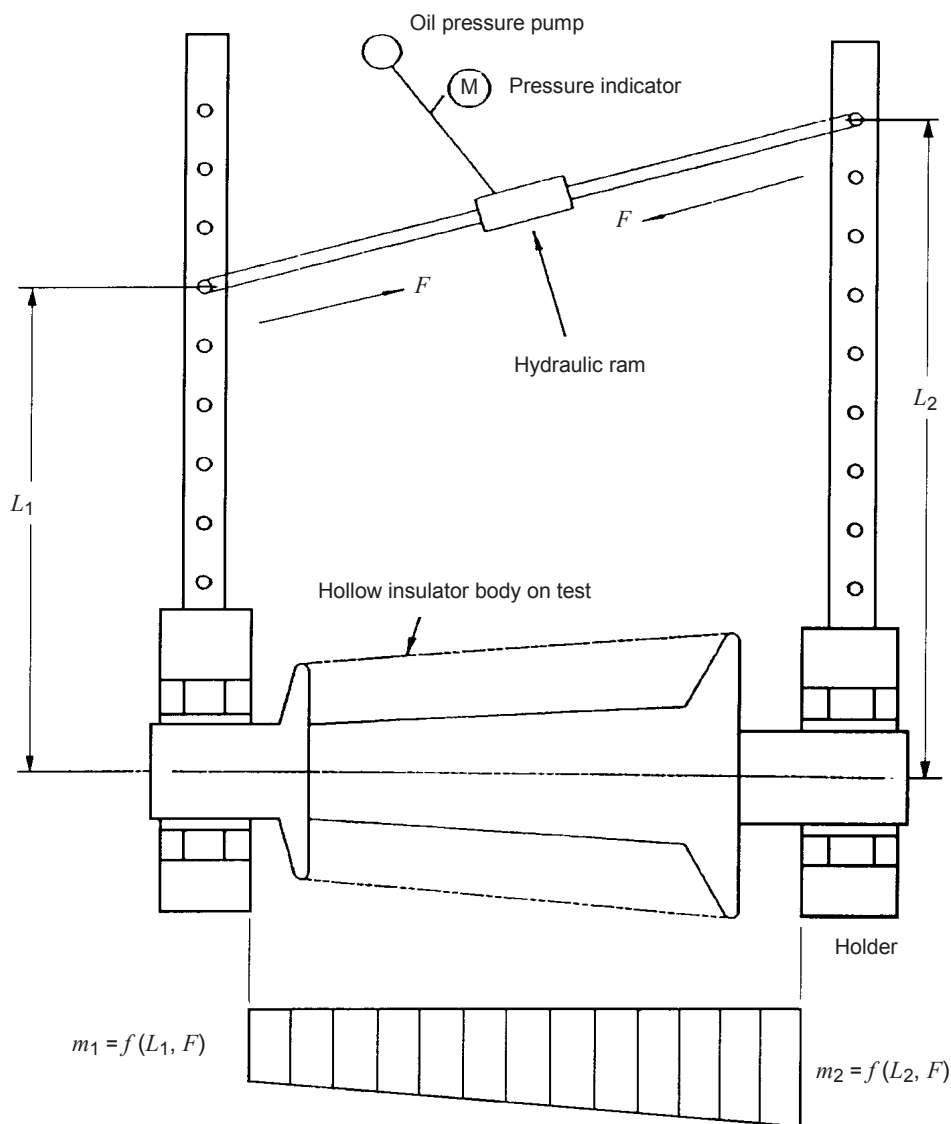

IEC 1094/03

- m_1, m_2 bending moment at the top or bottom metal fitting, respectively, of the unit when the assembled hollow insulator body is subject to the specified mechanical failing load
- L_1, L_2 effective length of the lever arm at the top or bottom metal fitting, respectively
- F load produced by the hydraulic ram
- $f()$ mathematical function

Figure B.2 – Test ram for non-uniform distributed bending moment

B.3 Test method with bending load applied

The hollow insulator body for test may be mounted vertically in a suitable test equipment, such as that shown schematically in Figure B.3. The lower end is suitably restrained whilst a load is applied horizontally to the free end of the hollow insulator body. The applied load shall be such that the bending moment developed at the lower end of the hollow insulator body is made equal to the bending moment on the unit when the hollow insulator is subject to the specified mechanical failing load. The load shall be applied in four mutually perpendicular directions, being released before the hollow insulator body is turned through 90°.

The test may be repeated by inverting the hollow insulator body and again applying the load in four mutually perpendicular directions.

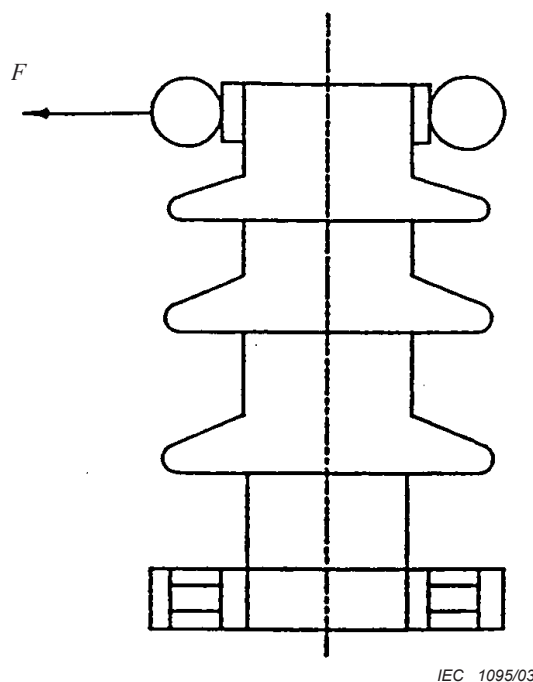
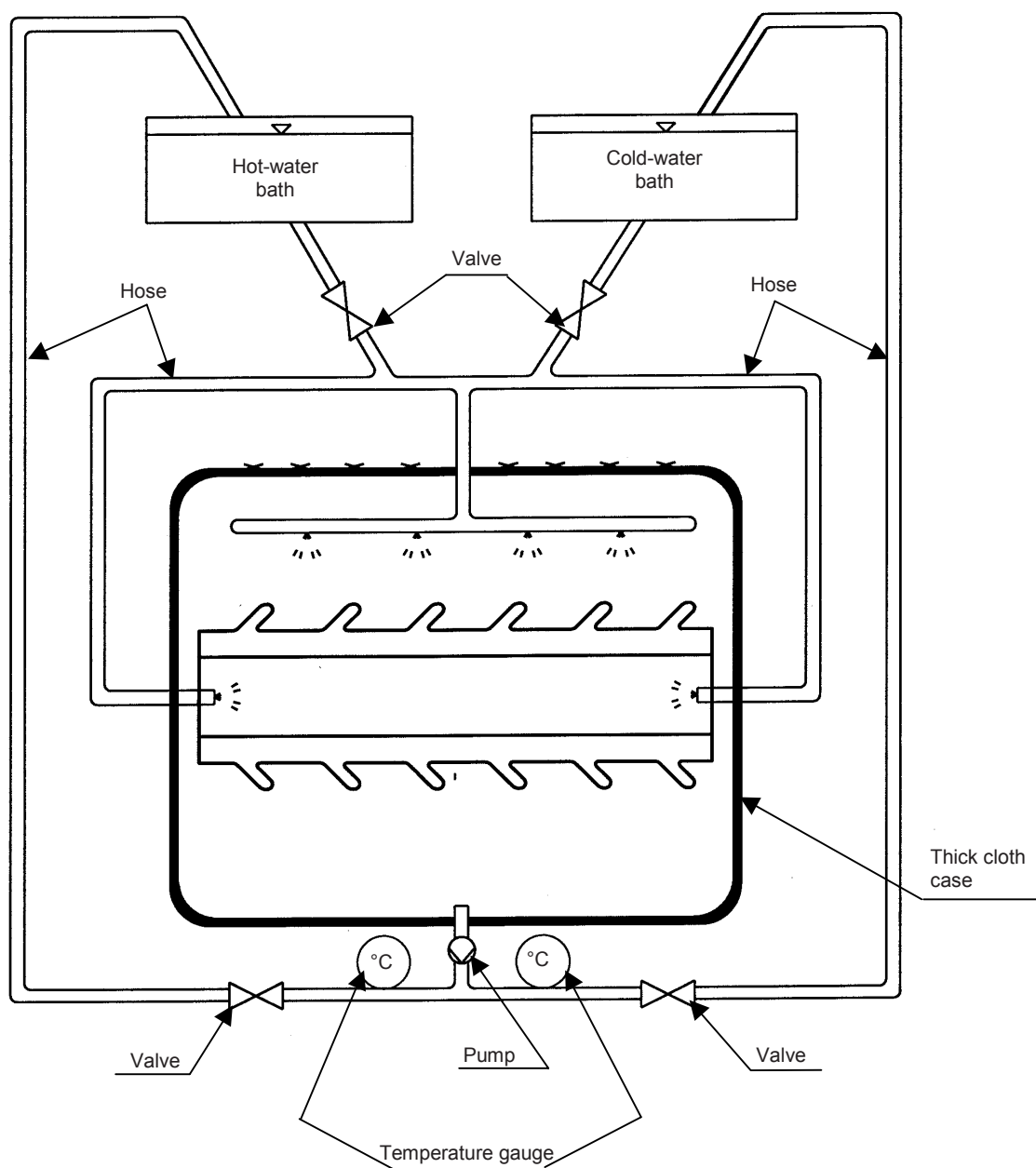

Figure B.3 – Test method with bending load applied

Annex C (informative)

Alternative test method for the temperature-cycle test

For large hollow insulators or hollow insulator bodies, an alternative test method of the temperature-cycle test may be used. The testing arrangement shall ensure controlled temperature-cycle and uniform water-spraying conditions. An arrangement according to Figure C.1 is suggested. The water temperature shall be checked by measuring the temperature of the return water.



IEC 1096/03

Figure C.1 – Alternative test arrangement for the temperature-cycle test

Annex D
(informative)

Bending moment equivalent to the design pressure

Conventionally, the bending moment M_b equivalent to the design pressure may be given the following value:

$$M_b = P \times \frac{\pi}{32} \times (D_s)^2 \times \frac{(D_o)^2 + (D_i)^2}{D_o}$$

where

P is the design pressure;

D_s is the sealing diameter;

D_o is the outside diameter of insulator body without sheds;

D_i is the inside diameter.

This simplified calculation is acceptable provided the axial stress σ_a due to pressure P is assumed to be uniform:

$$\sigma_a = P \times \frac{(D_s)^2}{(D_o)^2 - (D_i)^2}$$

This is relatively small compared to the maximum axial stress σ_b due to the maximum permanent bending moment in service M_{max} for example not above 25 % of

$$\sigma_b = M_{max} \times \frac{32}{\pi} \times \frac{D_o}{(D_o)^4 - (D_i)^4}$$

Figure D.1 provides diameters for determining the equivalent bending moment to the design pressure.

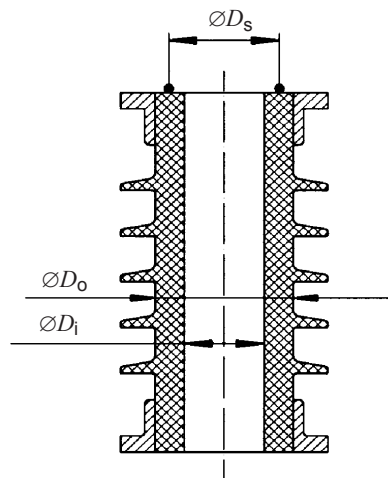

IEC 1097/03

Figure D.1 – Diameters for determining the equivalent bending moment to the design pressure

Annex ZA (normative)

Normative references to international publications with their corresponding European publications

This European Standard incorporates by dated or undated reference, provisions from other publications. These normative references are cited at the appropriate places in the text and the publications are listed hereafter. For dated references, subsequent amendments to or revisions of any of these publications apply to this European Standard only when incorporated in it by amendment or revision. For undated references the latest edition of the publication referred to applies (including amendments).

NOTE When an international publication has been modified by common modifications, indicated by (mod), the relevant EN/HD applies.

<u>Publication</u>	<u>Year</u>	<u>Title</u>	<u>EN/HD</u>	<u>Year</u>
IEC 60672-3	1997	Ceramic and glass-insulating materials Part 3: Specifications for individual materials	EN 60672-3	1997
IEC 60694	1996	Common specifications for high-voltage switchgear and controlgear standards	EN 60694 + corr. May	1996 1999
IEC 60865-1	1993	Short-circuit currents - Calculation of effects Part 1: Definitions and calculation methods	EN 60865-1	1993
IEC 61166	1993	High-voltage alternating current circuit- breakers - Guide for seismic qualification of high-voltage alternating current circuit-breakers	EN 61166	1993
IEC 61463	1996	Bushings - Seismic qualification	-	-
IEC 62271-100	2001	High-voltage switchgear and controlgear Part 100: High-voltage alternating- current circuit-breakers	EN 62271-100	2001
ISO 1460	1992	Metallic coatings - Hot dip galvanized coatings on ferrous metals - Gravimetric determination of the mass per unit area	EN ISO 1460	1994
ISO 1461	1999	Hot dip galvanized coatings on fabricated iron and steel articles - Specifications and test methods	EN ISO 1461	1999
ISO 1463	1982	Metallic and oxide coatings - Measurement of coating thickness - Microscopical method	EN ISO 1463	1994
ISO 2064	1996	Metallic and other inorganic coatings - Definitions and conventions concerning the measurement of thickness	EN ISO 2064	2000
ISO 2178	1982	Non-magnetic coatings on magnetic substrates - Measurement of coating thickness - Magnetic method	EN ISO 2178	1995

<u>Publication</u>	<u>Year</u>	<u>Title</u>	<u>EN/HD</u>	<u>Year</u>
ISO 4287	1997	Geometrical Product Specifications (GPS) - Surface texture: Profile method - Terms, definitions and surface texture parameters	EN ISO 4287	1998

Annex ZB (informative)

A-deviations

A-deviation: national deviation due to regulations, the alteration of which is for the time being outside the competence of the CEN/CENELEC member.

In the relevant CENELEC countries these A-deviations are valid instead of the provision of the European Standard until they have been removed.

<u>Clause</u>	<u>Legal reference + deviation</u>
Italy	
1	<p>(I.S.P.E.S.L. Rules, 95 revision: VSR. 8.B.1; VSR. 8.B.2; M.15.D.2)</p> <p>Italian laws apply to gas pressurized enclosures made of both insulating and metallic materials with a capacity of 25 litres or above, a design pressure higher than 0,05 kg/cm² and a temperature range: -25 °C/+100 °C (only for insulating materials).</p> <p>Moreover the manufacturer of any electrical equipment which comprehends gas pressurized enclosures must submit the design of the pressurized enclosures itself to a proper legal Authority indicating the stresses and the loads which have any influence on the design itself. For each of the stresses the manufacturer must indicate the design values and the relevant computations.</p>
4 and 5.2.2	<p>(I.S.P.E.S.L. Rules, 95 revision: VSR. 8.B.1 and M.15.D.3. Tab I for porcelain)</p> <p>Only the use of porcelain type "A or S" (Aluminous or Siliceous) is permitted.</p>
6.1.1	<p>(I.S.P.E.S.L. Rules, 95 revision: VSR. 8.B.1 Clause 2)</p> <p>The type test shall be performed in the presence of the Authority Supervisor.</p>
7.2.1 and 8.2	<p>(I.S.P.E.S.L. Rules, 95 revision: VSR. 8.B.2 Clause 2; M.15.D.4)</p> <p>An additional pressure test shall be performed on a complete pressurized enclosure. This has withstand 1,5 times the design pressure without failure for five minutes.</p> <p>Temperature cycles test and electrical test shall be made; after these tests it shall be carried out consecutively the pressure test at pressure $p \geq 4,25$ times the design pressure.</p>
9.2	<p>(I.S.P.E.S.L. Rules, 95 revision: VSR. 8.B.1 subclause 4.1.2)</p> <p>For a homogeneous batch of 100 pieces maximim, one hollow insulator shall be subjected to the failure test with a pressure 4,25 times the pressure design.</p>
10.2	<p>(I.S.P.E.S.L. Rules, 95 revision: M.15.D.4; VSR. 8.B.1 subclause 4.1.2)</p> <p>Routine tests comprise</p> <ul style="list-style-type: none"> • routine temperature cycle test (M.15.D.4), • pressure test on a complete pressurized enclosure, $p = 1,1$ times the design pressure (VSR.8.B.1 subclause 4.1.2).
11.1	<p>(I.S.P.E.S.L. Rules, 95 revision: M.15.D.5)</p> <p>Add the following text:</p> <p>Moreover each hollow insulator body shall be marked with a distinctive letter "A" or "S" for porcelain and with the design pressure.</p>

11.2 (I.S.P.E.S.L. Rules, 95 revision: M.15.D.6; VSR. 8.B.1)

The insulator manufacturer shall be provided with certificates containing the information reported in I.S.P.E.S.L. Rules, 95 revision: M.15.D.6, and the equipment manufacturer with certificates containing the information reported in I.S.P.E.S.L. Rules, 95 revision: VSR. 8.B.1.

I.S.P.E.S.L.: Istituto Superiore per la Prevenzione e la Sicurezza del Lavoro.

NOTE A.N.C.C. (Associazione Nazionale per il Controllo della Combustione) was replaced by I.S.P.E.S.L.

Bibliography

The following International Standards are referred to in this standard for information.

- [1] ISO 9001:1994, *Quality systems – Model for quality assurance in design, development, production, installation and servicing*
- [2] ISO 9002:1994, *Quality systems – Model for quality assurance in production, installation and servicing*
- [3] ISO 9003:1994, *Quality systems – Model for quality assurance in final inspection and test*
- [4] IEC 60672-1:1995, *Ceramic and glass insulating materials – Part 1: Definitions and classification*

The following International Standards provide more background information:

IEC 60815:1986, *Guide for the selection of insulators in respect of polluted conditions*

IEC 60865-2:1994, *Short-circuit currents – Calculation of effects – Part 2: Examples of calculation*

ISO 9004:2000, *Quality management systems – Part 1: Guidelines for performance improvements*

IEC 60050(471):1984, *International Electrotechnical Vocabulary (IEV) – Chapter 471: Insulators*

IEC 60273:1990, *Characteristics of indoor and outdoor post insulators for systems with nominal voltages greater than 1 000 V*

IEC 60437:1997, *Radio interference test on high-voltage insulators*

IEC 60507:1991, *Artificial pollution tests on high-voltage insulators to be used on a.c. systems*

IEC 61245:1993, *Artificial pollution tests on high-voltage insulators to be used on d.c. systems*

IEC 61462:1998, *Composite insulators – Hollow insulators for use in outdoor and indoor electrical equipment – Definitions, test methods, acceptance criteria and design recommendations*

ISO 1101:1983, *Technical drawings – Geometrical tolerancing – Tolerancing of form, orientation, location and run-out – Generalities, definitions, symbols, indications on drawings*

BSI — British Standards Institution

BSI is the independent national body responsible for preparing British Standards. It presents the UK view on standards in Europe and at the international level. It is incorporated by Royal Charter.

Revisions

British Standards are updated by amendment or revision. Users of British Standards should make sure that they possess the latest amendments or editions.

It is the constant aim of BSI to improve the quality of our products and services. We would be grateful if anyone finding an inaccuracy or ambiguity while using this British Standard would inform the Secretary of the technical committee responsible, the identity of which can be found on the inside front cover.
Tel: +44 (0)20 8996 9000. Fax: +44 (0)20 8996 7400.

BSI offers members an individual updating service called PLUS which ensures that subscribers automatically receive the latest editions of standards.

Buying standards

Orders for all BSI, international and foreign standards publications should be addressed to Customer Services. Tel: +44 (0)20 8996 9001.
Fax: +44 (0)20 8996 7001. Email: orders@bsi-global.com. Standards are also available from the BSI website at <http://www.bsi-global.com>.

In response to orders for international standards, it is BSI policy to supply the BSI implementation of those that have been published as British Standards, unless otherwise requested.

Information on standards

BSI provides a wide range of information on national, European and international standards through its Library and its Technical Help to Exporters Service. Various BSI electronic information services are also available which give details on all its products and services. Contact the Information Centre.
Tel: +44 (0)20 8996 7111. Fax: +44 (0)20 8996 7048. Email: info@bsi-global.com.

Subscribing members of BSI are kept up to date with standards developments and receive substantial discounts on the purchase price of standards. For details of these and other benefits contact Membership Administration.
Tel: +44 (0)20 8996 7002. Fax: +44 (0)20 8996 7001.
Email: membership@bsi-global.com.

Information regarding online access to British Standards via British Standards Online can be found at <http://www.bsi-global.com/bsonline>.

Further information about BSI is available on the BSI website at <http://www.bsi-global.com>.

Copyright

Copyright subsists in all BSI publications. BSI also holds the copyright, in the UK, of the publications of the international standardization bodies. Except as permitted under the Copyright, Designs and Patents Act 1988 no extract may be reproduced, stored in a retrieval system or transmitted in any form or by any means – electronic, photocopying, recording or otherwise – without prior written permission from BSI.

This does not preclude the free use, in the course of implementing the standard, of necessary details such as symbols, and size, type or grade designations. If these details are to be used for any other purpose than implementation then the prior written permission of BSI must be obtained.

Details and advice can be obtained from the Copyright & Licensing Manager.
Tel: +44 (0)20 8996 7070. Fax: +44 (0)20 8996 7553.
Email: copyright@bsi-global.com.