

Electricity metering — Data exchange for meter reading, tariff and load control —

Part 42: Physical layer services and procedures for connection-oriented asynchronous data exchange

The European Standard EN 62056-42:2002 has the status of a
British Standard

ICS 91.140.50; 35.100.10

National foreword

This British Standard is the official English language version of EN 62056-42:2002. It is identical with IEC 62056-42:2002.

The UK participation in its preparation was entrusted to Technical Committee PEL/13, Electricity meters, which has the responsibility to:

- aid enquirers to understand the text;
- present to the responsible international/European committee any enquiries on the interpretation, or proposals for change, and keep the UK interests informed;
- monitor related international and European developments and promulgate them in the UK.

A list of organizations represented on this committee can be obtained on request to its secretary.

From 1 January 1997, all IEC publications have the number 60000 added to the old number. For instance, IEC 27-1 has been renumbered as IEC 60027-1. For a period of time during the change over from one numbering system to the other, publications may contain identifiers from both systems.

Cross-references

The British Standards which implement international or European publications referred to in this document may be found in the BSI Standards Catalogue under the section entitled "International Standards Correspondence Index", or by using the "Find" facility of the BSI Standards Electronic Catalogue.

A British Standard does not purport to include all the necessary provisions of a contract. Users of British Standards are responsible for their correct application.

Compliance with a British Standard does not of itself confer immunity from legal obligations.

This British Standard, having been prepared under the direction of the Electrotechnical Sector Policy and Strategy Committee, was published under the authority of the Standards Policy and Strategy Committee on 16 July 2002

Summary of pages

This document comprises a front cover, an inside front cover, the EN title page, pages 2 to 27, and a back cover.

The BSI copyright date displayed in this document indicates when the document was last issued.

Amendments issued since publication

Amd. No.	Date	Comments

© BSI 16 July 2002

ISBN 0 580 39993 1

EUROPEAN STANDARD

EN 62056-42

NORME EUROPÉENNE

EUROPÄISCHE NORM

June 2002

ICS 91.140.50; 35.100.10

English version

**Electricity metering -
Data exchange for meter reading, tariff and load control
Part 42: Physical layer services and procedures
for connection-oriented asynchronous data exchange
(IEC 62056-42:2002)**

Equipements de mesure
de l'énergie électrique -
Echange des données pour la lecture
des compteurs, le contrôle des tarifs
et de la charge
Partie 42: Services et procédures
de la couche physique pour l'échange
de données à l'aide de connexion
asynchrone
(CEI 62056-42:2002)

Messung der elektrischen Energie -
Zählerstandsübertragung,
Tarif- und Laststeuerung
Teil 42: Bitübertragungsschichtdienste
und Verfahren für verbindungsorientierten
asynchronen Datenaustausch
(IEC 62056-42:2002)

This European Standard was approved by CENELEC on 2002-03-01. CENELEC members are bound to comply with the CEN/CENELEC Internal Regulations which stipulate the conditions for giving this European Standard the status of a national standard without any alteration.

Up-to-date lists and bibliographical references concerning such national standards may be obtained on application to the Central Secretariat or to any CENELEC member.

This European Standard exists in three official versions (English, French, German). A version in any other language made by translation under the responsibility of a CENELEC member into its own language and notified to the Central Secretariat has the same status as the official versions.

CENELEC members are the national electrotechnical committees of Austria, Belgium, Czech Republic, Denmark, Finland, France, Germany, Greece, Hungary, Iceland, Ireland, Italy, Luxembourg, Malta, Netherlands, Norway, Portugal, Slovakia, Spain, Sweden, Switzerland and United Kingdom.

CENELEC

European Committee for Electrotechnical Standardization
Comité Européen de Normalisation Electrotechnique
Europäisches Komitee für Elektrotechnische Normung

Central Secretariat: rue de Stassart 35, B - 1050 Brussels

Foreword

The text of document 13/1266/FDIS, future edition 1 of IEC 62056-42, prepared by IEC TC 13, Equipment for electrical energy measurement and load control, was submitted to the IEC-CENELEC parallel vote and was approved by CENELEC as EN 62056-42 on 2002-03-01.

The following dates were fixed:

- latest date by which the EN has to be implemented at national level by publication of an identical national standard or by endorsement (dop) 2003-01-01
- latest date by which the national standards conflicting with the EN have to be withdrawn (dow) 2005-03-01

The International Electrotechnical Commission (IEC) and CENELEC draw attention to the fact that it is claimed that compliance with this International Standard / European Standard may involve the use of a maintenance service concerning the stack of protocols on which the present standard IEC 62056-42 / EN 62056-42 is based.

The IEC and CENELEC take no position concerning the evidence, validity and scope of this maintenance service.

The provider of the maintenance service has assured the IEC that he is willing to provide services under reasonable and non-discriminatory terms and conditions with applicants throughout the world. In this respect, the statement of the provider of the maintenance service is registered with the IEC. Information (see also 6.3.3) may be obtained from:

DLMS¹⁾ User Association
Geneva / Switzerland
www.dlms.ch

Annexes designated "normative" are part of the body of the standard.
Annexes designated "informative" are given for information only.
In this standard, annexe ZA is normative and annexes A and B are informative.
Annex ZA has been added by CENELEC.

Endorsement notice

The text of the International Standard IEC 62056-42:2002 was approved by CENELEC as a European Standard without any modification.

In the official version, for Bibliography, the following notes have to be added for the standards indicated:

IEC 61334-4-41	NOTE	Harmonized as EN 61334-4-41:1996 (not modified).
IEC 61334-6	NOTE	Harmonized as EN 61334-6:2000 (not modified).

¹⁾ Device Language Message Specification

CONTENTS

1	Scope.....	4
2	Normative references	4
3	Terms, definitions and abbreviations	5
4	Overview	6
5	Service specification.....	7
5.1	List of services	7
5.1.1	Connection establishment/release related services.....	7
5.1.2	Data communication services	7
5.1.3	Layer management services	7
5.2	Use of the physical layer services	8
5.3	Service definitions.....	8
5.3.1	PH-CONNECT.request	8
5.3.2	PH-CONNECT.indication	9
5.3.3	PH-CONNECT.confirm	9
5.3.4	PH-ABORT.request	10
5.3.5	PH-ABORT.confirm	10
5.3.6	PH-ABORT.indication	10
5.3.7	PH-DATA.request	11
5.3.8	PH-DATA.indication.....	11
6	Protocol specification	12
6.1	Physical layer protocol data unit.....	12
6.2	Transmission order and characteristics	12
6.3	Physical layer operation – description of the procedures	12
6.3.1	General	12
6.3.2	Setting up a physical connection	13
6.3.3	The identification service.....	14
6.3.4	Data communications	18
6.3.5	Disconnection of an existing physical connection.....	18
Annex A (informative) An example: PH service primitives and Hayes commands		19
Annex B (informative) Data model and protocol		24
Annex ZA (normative) Normative references to international publications with their corresponding European publications		27
Bibliography.....		25
Figure 1 – Typical PSTN configuration		6
Figure 2 – The location of the physical layer		7
Figure 3 – Protocol layer services of the COSEM 3-layer connection oriented profile.....		8
Figure 4 – MSC for physical connection establishment.....		14
Figure 5 – MSC for IDENTIFY.request/.response message exchange		16
Figure 6 – Handling the identification service at the COSEM server side.....		16
Figure 7 – Partial state machine for the client side physical layer.....		17
Figure A.1 – MSC for physical connection request		19
Figure A.2 – Physical connection establishment at the CALLING station.....		20
Figure A.3 – MSC for physical connection establishment		21
Figure A.4 – Data exchange between the calling and called stations.....		22
Figure A.5 – MSC for a physical disconnection		23
Figure B.1 – The three-step approach of COSEM		24

ELECTRICITY METERING – DATA EXCHANGE FOR METER READING, TARIFF AND LOAD CONTROL –

Part 42: Physical layer services and procedures for connection-oriented asynchronous data exchange

1 Scope

This part of IEC 62056 specifies the physical layer services and protocols within the Companion Specification for Energy Metering (COSEM) three-layer connection oriented profile for asynchronous data communication. The document does not specify physical layer signals and mechanical aspects. Local, implementation-specific issues are also not specified.

In annex A, an example of how this physical layer can be used for data exchange through the Public Switched Telephone Network (PSTN) using intelligent Hayes modems is given.

The use of the physical layer for the purposes of direct local data exchange using an optical port or a current loop physical interface is specified in IEC 62056-21.

Annex B gives an explanation of the role of data models and protocols in electricity meter data exchange.

2 Normative references

The following referenced documents are indispensable for the application of this document. For dated references, only the edition cited applies. For undated references, the latest edition of the referenced document (including any amendments) applies.

IEC 60050-300:2001, *International Electrotechnical Vocabulary –Electrical and electronic measurements and measuring instruments – Part 311: General terms relating to measurements – Part 312: General terms relating to electrical measurements – Part 313: Types of electrical measuring instruments – Part 314: Specific terms according to the type of instrument*

IEC/TR 62051:1999, *Electricity metering – Glossary of terms*

IEC 62056-21, *Electricity metering – Data exchange for meter reading, tariff and load control – Part 21: Direct local data exchange*¹

IEC 62056-46, *Electricity metering – Data exchange for meter reading, tariff and load control – Part 46: Data link layer using HDLC protocol*¹

IEC 62056-53, *Electricity metering – Data exchange for meter reading, tariff and load control – Part 53: COSEM application layer*¹

IEC 62056-61, *Electricity metering – Data exchange for meter reading, tariff and load control – Part 61: OBIS Object identification system*¹

IEC 62056-62, *Electricity metering – Data exchange for meter reading, tariff and load control – Part 62: Interface objects*¹

NEMA C12.21:1999, *Protocol Specification for Telephone Modem Communication*

¹ To be published.

3 Terms, definitions and abbreviations

3.1 Terms and definitions

For the purpose of this part of IEC 62056, the definitions in IEC 60050-300 and IEC/TR 62051 as well as the following definitions apply:

3.1.1

client

a station asking for services, normally the master station

3.1.2

master

central station – station which takes the initiative and controls the data flow

3.1.3

server

a station delivering services. The tariff device (meter) is normally the server, delivering the requested values or executing the requested tasks

3.1.4

slave

station responding to requests of a master station. The tariff device (meter) is normally a slave station

3.2 Abbreviations

COSEM	COmpanion Specification for Energy Metering
DCE	Data Communication Equipment (communications interface or modem)
DTE	Data Terminal Equipment (computers, terminals or printers)
MSC	Message Sequence Chart
PDU	Protocol Data Unit
PH	PHysical layer
PHPDU	PHysical layer Protocol Data Unit
PHSDU	PHysical layer Service Data Unit
SDU	Service Data Unit

4 Overview

From the external point of view, the physical layer provides the interface between the DTE and the DCE, see

Figure 2. Figure 1 shows a typical configuration for data exchange through a wide area network, for example the PSTN.

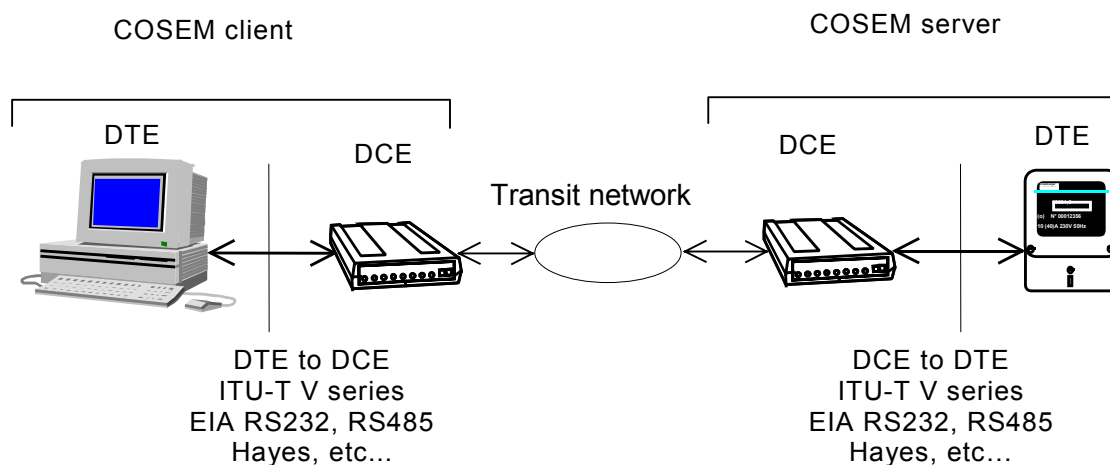

IEC 235/02

Figure 1 – Typical PSTN configuration

From the physical connection point of view, all communications involve two sets of equipment represented by the terms caller system and called system. The caller is the system that decides to initiate a communication with a remote system known as the called party; these denominations remain valid throughout the duration of the communication. A communication is broken down into a certain number of transactions. Each transaction is represented by a transmission from the transmitter to the receiver. During the sequence of transactions, the caller and called systems take turns to act as transmitter and receiver.

From the data link point of view the central station normally acts as a master, taking the initiative and controlling the data flow. The tariff device is the slave, responding to the master station.

From the application point of view the central station normally acts as a client asking for services, and the tariff device acts as a server delivering the requested services.

The situation involving a caller client and a called server is undoubtedly the most frequent case, but a communication based on a caller server and a called client is also possible, in particular to report the occurrence of an urgent alarm.

For the purpose of local data exchange, two DTEs can be directly connected using appropriate connections.

To allow using a wide variety of media, this standard does not specify the physical layer signals and their characteristics. However, the following assumptions are made:

- the communication is point to point or point to multipoint;
- both half-duplex and duplex connections are possible;
- asynchronous transmission with 1 start bit, 8 data bits, no parity and 1 stop bit (8N1).

From the internal point of view, the physical layer is the lowest layer in the protocol stack.

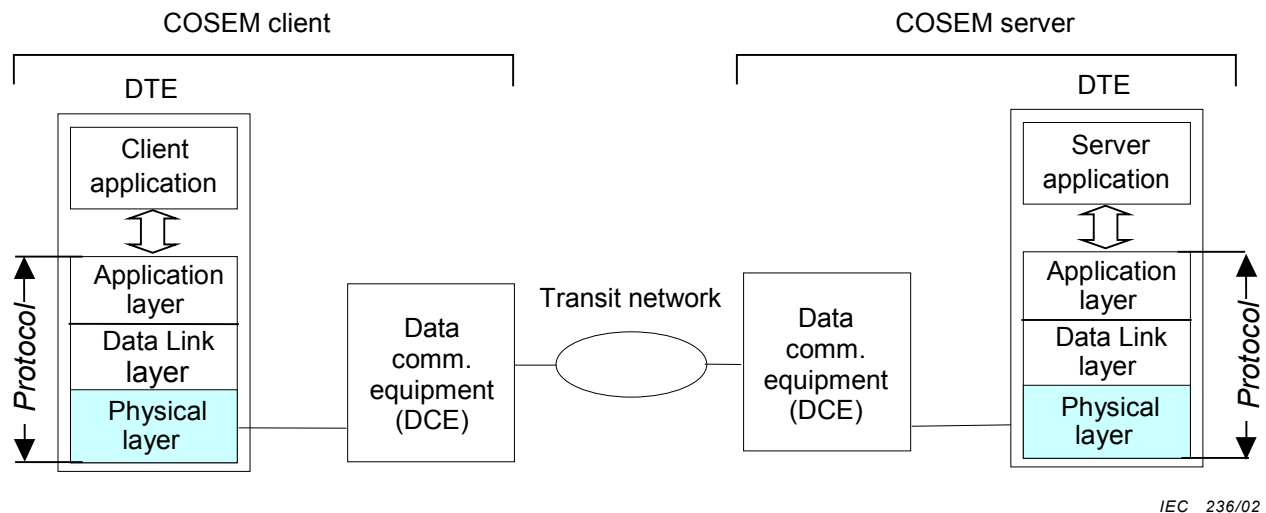

IEC 236/02

Figure 2 – The location of the physical layer

This standard defines the services of the physical layer towards its peer layer(s) and the upper layers, and the protocol of the physical layer.

5 Service specification

5.1 List of services

ITU-T X.211 defines a set of capabilities to be made available by the physical layer over the physical media. These capabilities are available via service primitives, as follows:

5.1.1 Connection establishment/release related services

PH-CONNECT.request / PH-CONNECT.indication / PH-CONNECT.confirm

PH-ABORT.request / PH-ABORT.confirm / PH-ABORT.indication

5.1.2 Data communication services

PH-DATA.request / PH-DATA.indication

5.1.3 Layer management services

In addition to the services above, some additional physical layer services may be necessary, which are used by or provided for the layer management process, which is part of the application process. Some examples are given below:

PH-INITIALIZE.request / PH-INITIALIZE.confirm

PH-GET_VALUE.request / PH-GET_VALUE.confirm

PH-SET_VALUE.request / PH-SET_VALUE.confirm

PH-LM_EVENT.indication

As these services are of local importance only, their definition is not within the scope of this standard.

5.2 Use of the physical layer services

Figure 3 shows how different service users use the service primitives of the physical layer.

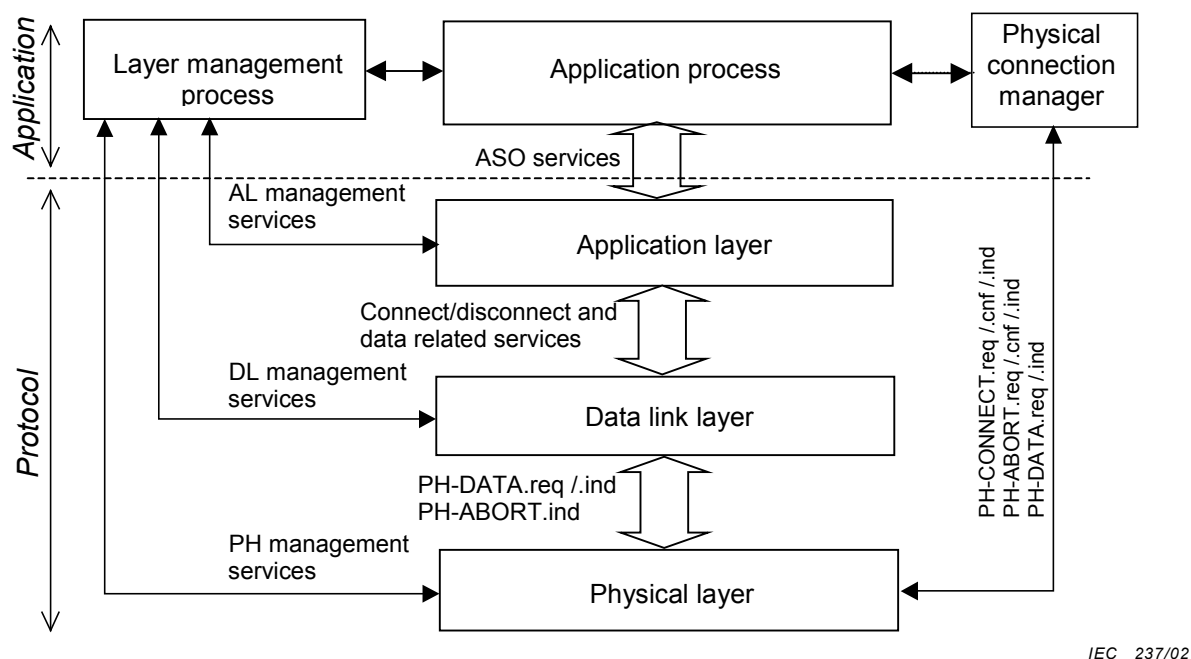

Figure 3 – Protocol layer services of the COSEM 3-layer connection oriented profile

As is shown in Figure 3, the connection establishment/release services are used by and provided for the physical connection manager application process, and not the data link layer. The reasons for this are explained in 6.3.1.

5.3 Service definitions

5.3.1 PH-CONNECT.request

Function

This primitive is invoked by the service user entity to request the setting up of a physical connection to a remote device.

NOTE In the COSEM environment, it is the physical connection manager application process.

Service parameters

The semantics of the primitive is as follows:

```
PH-CONNECT.request
(
    PhConnType,
    PhConnReqParams
)
```

The PhConnType parameter specifies the type of connection requested, for example direct connection, PSTN modem connection, etc. This standard does not specify data/type(s) and/or value(s) for this parameter, because this is a local issue only.

The structure and the contents of the PhConnReqParams parameter depend on the value of the PhConnType parameter. For example, in the case of a PSTN connection it includes the phone number of the remote station, etc. As – similarly to the PhConnType parameter – the PhConnReqParams parameter contains implementation dependent data, data types/values for this parameter are not specified in this standard.

Use

The PH-CONNECT.request primitive is used for the establishment of a physical connection. The receipt of this primitive causes the PH-Layer entity to perform the required actions, for example dial the specified phone number, to establish a physical connection with the peer physical layer entity. An example of these actions in the case of an intelligent Hayes modem is given in annex A.

5.3.2 PH-CONNECT.indication

Function

This primitive is generated by the physical layer entity to indicate to the service user entity that a remote device requests that a physical connection to the local physical layer be established.

Service parameters

The semantics of the primitive is as follows:

```
PH-CONNECT.indication ( )
```

Use

The PH-CONNECT.indication primitive is used by the PH entity to indicate to the service user entity that a remote device requests that a physical connection be established.

5.3.3 PH-CONNECT.confirm

Function

This primitive is generated by the PH entity to convey the results of the associated PH-CONNECT.request to the service user entity.

Service parameters

The semantics of the primitive is as follows:

```
PH-CONNECT.confirm
(
  Result,
  PhConnCnfParams
)
```

The result parameter indicates whether the attempt to set up a physical connection was successful or not.

The structure and the value of the PhConnCnfParams parameter depend on the physical connection type of the corresponding CONNECTION.request service, which is actually being confirmed. For example, in the case of a PSTN connection it may include parameters of the established connection (V22, baud-rate, etc.). Data types and values for either the Result or the PhConnCnfParams parameter are not specified in this standard.

If the connection could not be established due to a local error – for example the phone line is not available – the PH-CONNECT.confirm service is locally generated.

Use

The PH-CONNECT.confirm primitive is used by the PH entity to convey the results of the associated PH-CONNECT.request.

5.3.4 PH-ABORT.request*Function*

This primitive is invoked by the service user entity to request the disconnection of an existing physical connection.

Service parameters

The semantics of the primitive is as follows:

```
PH-ABORT.request ( )
```

Use

The PH-ABORT.request primitive is used to request the physical layer entity to terminate an existing physical connection.

5.3.5 PH-ABORT.confirm*Function*

This primitive is generated by the physical layer entity to indicate to the service user entity whether the request to terminate the physical connection was successful or not.

Service parameters

The semantics of the primitive is as follows:

```
PH-ABORT.confirm
(
    Result
)
```

The Result parameter carries the result of the physical disconnection attempt.

Use

The PH-ABORT.confirm primitive is used by the PH entity to confirm to the service user entity the result of a physical disconnection attempt.

5.3.6 PH-ABORT.indication*Function*

This primitive is generated by the physical layer entity to indicate to the service user entity a non-requested termination of a physical connection.

Service parameters

The semantics of the primitive is as follows:

```
PH-ABORT.indication( )
```

Use

The PH-ABORT.indication primitive is used by the PH entity to inform the service user entity that a physical connection has been unexpectedly terminated.

5.3.7 PH-DATA.request*Function*

This primitive is invoked by the service user entity to request sending a data byte to one or several remote PH entity or entities using the PH transmission procedures.

Service parameters

The semantics of this primitive is as follows:

```
PH-DATA.request
(
    Data
)
```

The data parameter carries the byte to be transmitted by the PH layer entity.

Use

The PH-DATA.request primitive is used by the service user entity whenever data is to be transmitted to its peer entity or entities.

The receipt of this primitive causes the PH entity to perform all PH specific actions and pass the PH service data unit – the received byte – to the physical data interface for transfer to the peer PH entity or entities.

5.3.8 PH-DATA.indication*Function*

This primitive is used to transfer data from the PH entity to the service user entity.

Service parameters

The semantics of this primitive is as follows:

```
PH-DATA.indication
(
    Data
)
```

The data parameter carries the received byte as received by the local PH entity.

Use

The PH-DATA.indication primitive is used by the PH entity to indicate to the service user entity the arrival of a valid data byte.

6 Protocol specification

6.1 Physical layer protocol data unit (PHPDU)

The PHPDU is specified to be one byte. For transmission purposes however this data byte may be extended (error detection / correction) or modified (bit-stuffing) by the modem device, depending on the modulation scheme used. See also explanation to Figure A.4 – Data exchange between the calling and called stations.

6.2 Transmission order and characteristics

The PHSDU byte – the data parameter of the PH-DATA services – shall be completed with one start bit and one stop bit before transmission. The resulting frame shall be transmitted starting with the start bit, followed by the least significant bit first, with the least significant bit identified as bit 0 and the most significant bit as bit 7.

All characteristics of the physical medium and the signal(s) used on this medium are not in the scope of this international standard.

6.3 Physical layer operation – description of the procedures

6.3.1 General

The physical layer – together with the physical media – is a shared resource for the higher protocol layers. Multiple higher layer connections/associations can be modelled as different instances of the protocol stack, which need to share the resources of the physical layer.

For this reason, the physical connection manager application process manages the physical connection establishment and release – see 6.3.2 and 6.3.5. Any application process wishing to use the COSEM protocol shall check the connection state of the physical layer before requesting a connection. If the physical layer is in non-connected state, it shall request the physical connection manager to establish the connection. If the application layer (see IEC 62056-53) invokes an COSEM-OPEN.request service and the corresponding physical connection is not established, the COSEM-OPEN.request will be locally confirmed with error = NO_PHYSICAL_CONNECTION (see in detail in IEC 62056-53).

Once the physical connection is established, the physical layer is ready to transmit data.

An optional identification service – as described in 6.3.3 – is available. This enables the client to identify the protocol stack implemented in the server.

After the identification procedure is completed – or if it is not used – the upper protocol layers and the applications can exchange data – see 6.3.4. The user of the PH-DATA services is the next protocol layer above the physical layer.

A physical disconnection may be requested by the physical connection manager (either on the server or the client side), or may occur in an unsolicited manner (e.g. the phone exchange cuts the line). While physical disconnection management is the exclusive responsibility of the physical connection manager, indication of an unsolicited disconnection (PH-ABORT.indication) is sent both to the next protocol layer and to the physical connection manager. See 6.3.5.

6.3.2 Setting up a physical connection

Both the client and the server device can act as a calling device, initiating a physical connection to a remote device, which is the called device.

The execution of the PH-CONNECT.request service depends on the physical connection type and on the modem used.

In Annex A, an example is given as to how this is performed in the case when intelligent Hayes modems are used through the PSTN.

In other cases, all the operations required – dialling, handling eventual error messages (busy, etc...), negotiating the line modulation/ baud-rate parameters, etc. – might be executed by the physical layer itself.

In order to allow using a wide variety of physical connection types, this international standard does not specify how the execution of the PH-CONNECT.request should be done.

At the called device side, when the physical connection initiation is detected, the connection needs to be managed: negotiated and accepted or refused. These actions – similarly for the execution of the PH-CONNECT.request service – depend on the physical connection type and on the modem used, and might be done in an autonomous manner or by the physical layer itself. The specification of these actions is not within the scope of this standard.

When the physical layers of the Calling and Called device complete establishing (or not establishing) the required physical connection, they inform the service user entity about the result, using the PH-CONNECT.confirm (calling side) and the PH-CONNECT.indication (called side) service primitives. In this COSEM profile, the service user of these service primitives is exclusively the physical connection manager process.

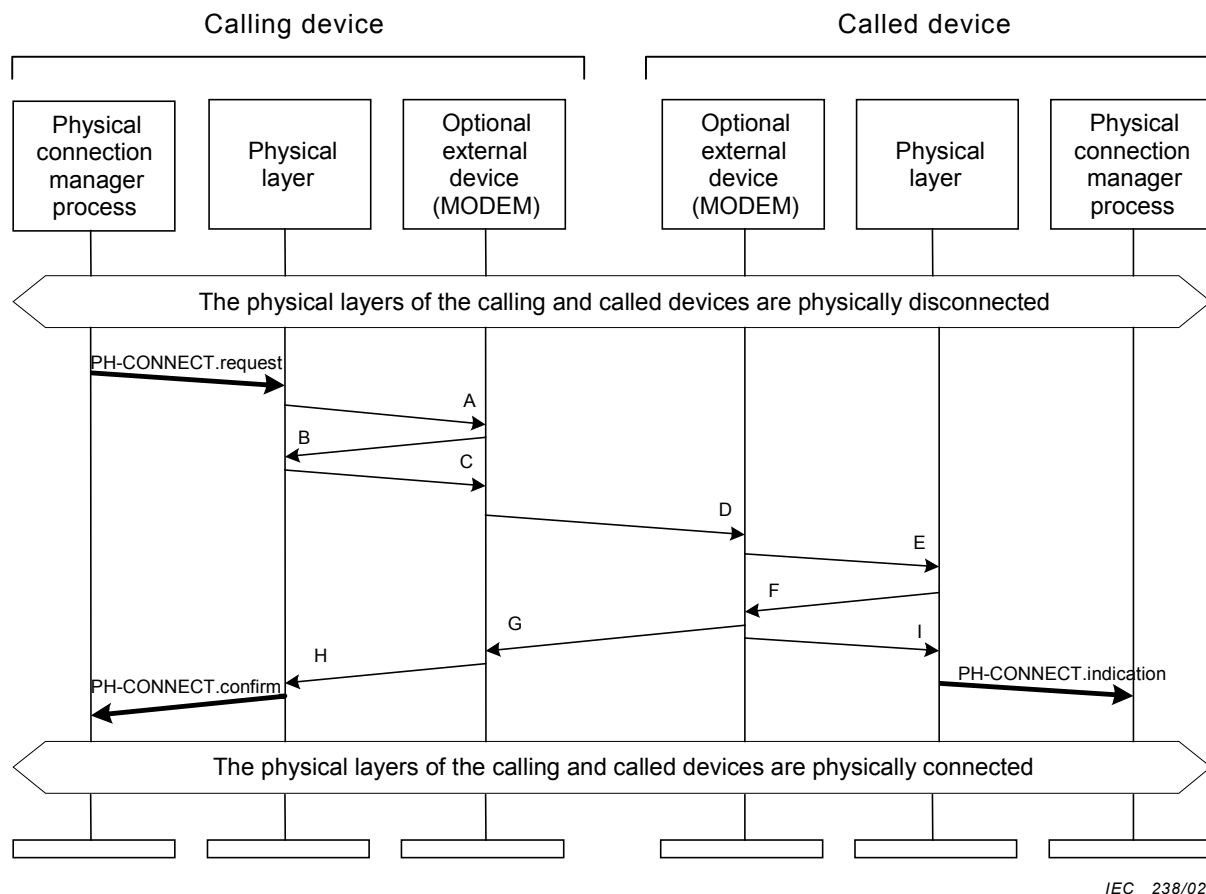

Figure 4 – MSC for physical connection establishment

As it is shown in Figure 4, this standard specifies only the PH-CONNECT.request/ .confirm/ .indication services: all other eventual message exchanges (A, B, C,....I) are out of the scope of this standard.

6.3.3 The identification service

6.3.3.1 General

The optional identification service is an application level service. Its purpose is to allow the client to obtain information about the protocol stack implemented in the server. Consequently, the identification service does not use the whole protocol stack; identification messages are exchanged directly between the application processes of the client and the server, using the data services of the physical layer. If more than one server is used in a multidrop configuration, the client is able to identify the protocol stack in each.

The identification service shall be the first service after establishing the physical connection. Although the connection can be initiated either by the client or the server, the identification request is always issued by the client.

NOTE As the identification service is the first service after establishing a physical connection, the physical connection manager application process could also provide this service.

6.3.3.2 Identification service message specification

IDENTIFY.request

The IDENTIFY.request message is issued by the application process of the client.

IDENTIFY.request ::= SEQUENCE

```
{
  IDENTIFY-Request-ID      Unsigned8 = 0x201),
  Multidrop-Device-ID     OCTET STRING( SIZE (2) ) OPTIONAL
}
```

When the multidrop-device-ID parameter is present, it addresses one physical device on a multi-drop configuration. Only the addressed device shall respond.

NOTE In multidrop configurations, the client has to send the I-command with an address field.

If the server side physical layer accepts this message as an identification message, it will be indicated to the identification service user application process as an IDENTIFY.indication message.

IDENTIFY.response

The IDENTIFY.response message is issued by the application process of the server and carries the result of the identification request: the protocol standard, version and revision information or an error message. On the client side, this is an IDENTIFY.confirm message.

IDENTIFY.response ::= SEQUENCE

```
{
  success-code  Unsigned8 = <OK>  -- 1)
  std-protocol-id  Unsigned8,      -- 2)
  std-protocol-ver  Unsigned8,      -- 2)
  std-protocol-rev  Unsigned8      -- 2)
}
```

NOTE The response – in case of success – shall be sent with a delay of 1 500 ms maximum.

The following codes shall be used, in conformance with NEMA C12.21:

success-code	–	0x00
std-protocol-id	–	0x04
std-protocol-ver	–	0x01
std-protocol-rev	–	0x00

If there was a problem with the identification message received, the received message shall be discarded and no response shall be sent. Otherwise, the response contains the success code <OK> and the identifier, version and revision of the protocol stack implemented. These identifiers are administrated by the DLMS User Association.

Important note: The IDENTIFY.request/.response messages are not encoded in A-XDR, like other PDUs: they are encoded simply as a sequence of bytes. This means that the IDENTIFY.request/indication message contains one byte or three bytes when the optional multidrop-device-id is present. The IDENTIFY.response/.confirm message contains four bytes in case of success.

1) In order to ensure compliance to existing implementations, the ASCII code of the 'I' character (0x49) may also be used as Identify-Request-ID.

2) As specified in NEMA C12.21.

6.3.3.3 Identification service protocol specification

Figure 5 shows the message sequence chart of the identification service in the case of success.

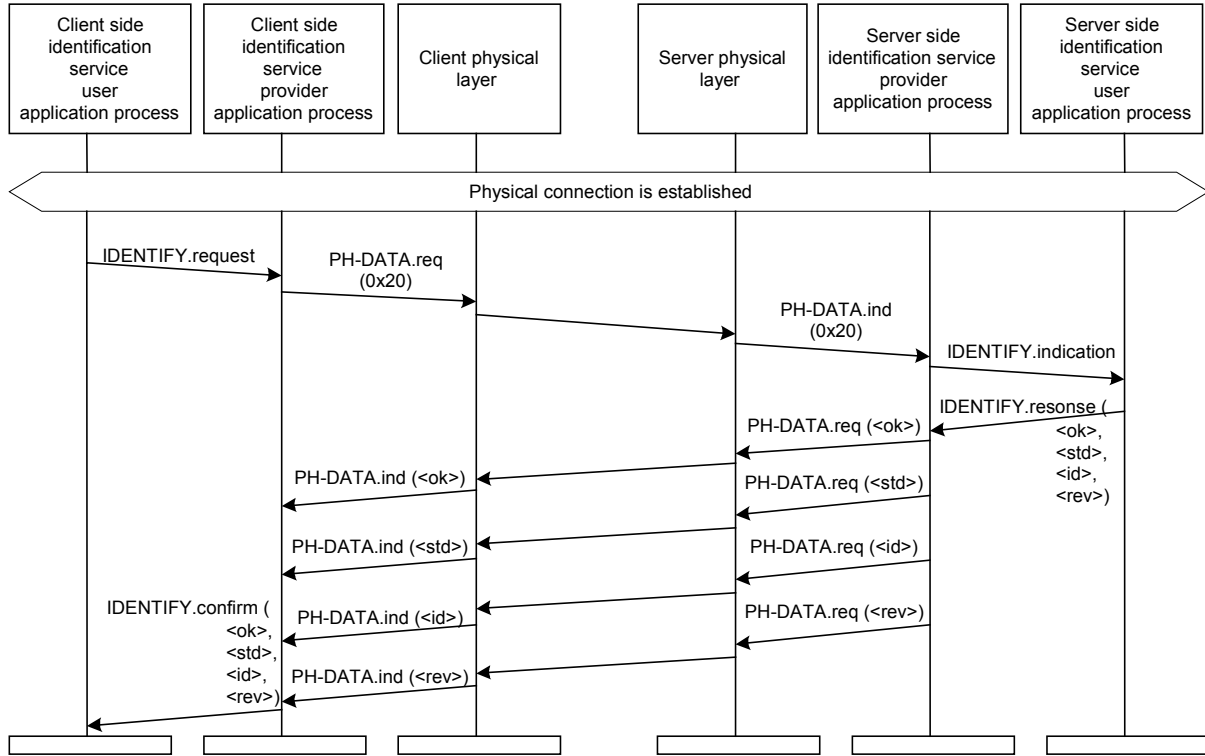

IEC 239/02

Figure 5 – MSC for IDENTIFY.request/response message exchange

Figure 6 shows the partial state-machine of the identification service of the server side physical layer.

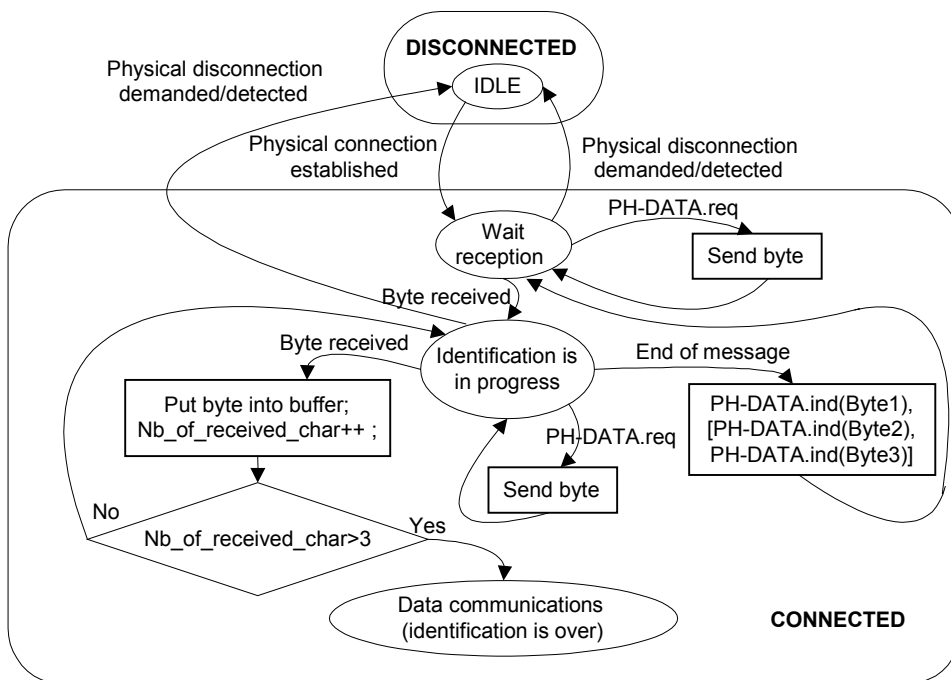

IEC 240/02

Figure 6 – Handling the identification service at the COSEM server side

The COSEM server physical layer enters the CONNECTED macro-state following the establishment of the physical connection and waits for the first byte of the IDENTIFY.request message in the 'wait reception' state.

The IDENTIFY.request message contains one or three bytes. For coherency, it shall be sent with the timing constraints of the data link layer (inter-character- and response time-outs).

When this first character is received, the physical layer enters the 'identification is in progress' state, waiting for more bytes or an inter-frame time-out, meaning the end of the message.

If the end of message condition is detected before receiving more than three bytes the physical layer considers the message received as an IDENTIFY.request message. It sends the bytes received to the (physical connection manager) application process using the PH-DATA.indication service and returns to the 'wait reception' state, allowing resolution of eventual errors.

On the other hand, if no end of message condition is detected before receiving the fourth incoming byte, the physical layer considers that the identification process is over, and enters into 'data communications' state. The incoming bytes shall be sent, using the PH-DATA.indication service, to the service user upper protocol layer. In the 3-layer, connection-oriented, HDLC based COSEM profile this is the MAC sub-layer. Within this connection, the physical layer can not return to the identification stage.

NOTE 1 The basic assumption of this state machine is that any upper layer PDU (here it is the MPDU) is longer than three characters.

NOTE 2 The state machine shown in Figure 6 is not complete, for example it is not indicated where the Nb_of_received_char layer parameter is set to its initial value; exit conditions and transitions from the 'data communications' state are not shown.

NOTE 3 This identification service definition ensures backward compatibility with client systems, which are not using the optional identification service. If the first message of the client is not an IDENTIFY.request – but longer than three characters – it shall be given to the data link layer and the identification stage is over, too.

The partial state machine for the client side physical layer is shown in Figure 7.

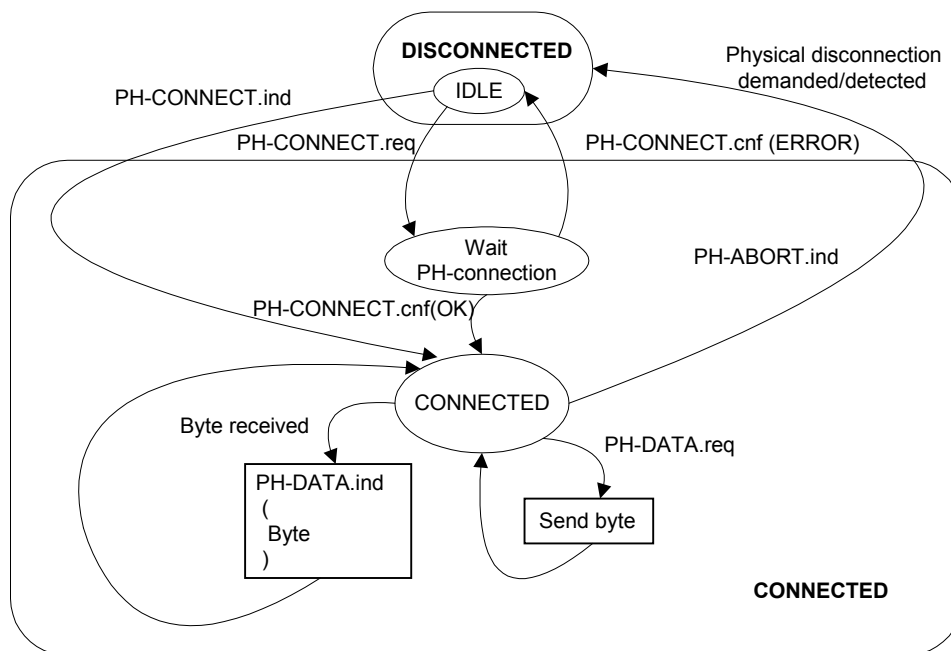

IEC 241/02

Figure 7 – Partial state machine for the client side physical layer

The client side physical layer uses a layer parameter, 'Destination_process', to decide where to send the data received. The layer parameter shall be managed by the layer management application process. When this parameter is not set (NULL), the physical layer shall send PH-DATA.indications to the (physical connection manager) application process. When the identification phase is over, the client application shall set the 'destination_process' parameter to point to the next upper layer of the protocol stack (the MAC sub-layer). From this moment PH-DATA.indications (and, in the case of a physical connection interruption, a copy of the PH-ABORT.indication) shall be sent to the upper protocol layer.

6.3.4 Data communications

Once the physical layer exits from the identification stage, it enters into the data communications stage, where PH-DATA.request and PH-DATA.indication services are exclusively used by the upper protocol layer, which is the data link layer IEC 62056-46.

The physical layer is not responsible for any data flow control function: the data received with a PH-DATA.request shall be either transmitted immediately, or – when a physical data flow control is implemented – shall overwrite the previous, not yet transmitted byte. As the PH-DATA.request service is neither locally nor remotely confirmed, no error shall be signalled in this latter case.

6.3.5 Disconnection of an existing physical connection

Either the client or the server can initiate the disconnection of an existing physical connection. This takes place by the physical connection manager application process invoking the PH-ABORT.request service, as it is shown in Figure 3.

The physical layer tries to disconnect the current physical connection and informs the requestor about the result via the PH-ABORT.confirm service.

The PH-ABORT.request service is always locally confirmed: the remote unit does not receive any message; it simply detects the disruption of the physical channel (e.g. the carrier is no longer available).

When the client or the server detects a physical disconnection – this can be the result of a PH-ABORT.request service invocation in the remote station but also due to a line error – the physical layer shall indicate this event using the PH-ABORT.indication service primitive. This service primitive shall be sent not only to the physical connection manager application process but also to the next higher protocol layer. This information is necessary for the upper layers to correctly close their connections after the disruption of the physical channel.

Annex A (informative)

An example: PH-layer service primitives and Hayes commands

A.1 General

The purpose of this annex is to describe the principles of using an intelligent modem below the physical layer interface. It is not the intention to give a complete reference of the Hayes command set or the possibilities provided by the physical layer.

The Hayes command set is mainly used in the PSTN modem environment. There is a difference between the command mode and the data transmission mode. In command mode, all commands are issued with a leading "AT". This enables the modem to adapt automatically to the baud rate and line parameters on DTE/DCE side. In data transmission mode, all data is passed to the remote DCE. Data are buffered if an additional data correction or compression mode is enabled.

A.2 Physical layer services and related message exchanges

In the following subclauses the use of the various commands is explained using examples and message sequence charts.

A.2.1 PH-CONNECT.request

The DTE requests to establish a physical connection with a remote DTE by transmitting the dial command together with the phone number to the DCE (*ATDPhoneNumber*).

Example: ATD049515101188

dials the phone number 049515101188 using the default dialling mode.

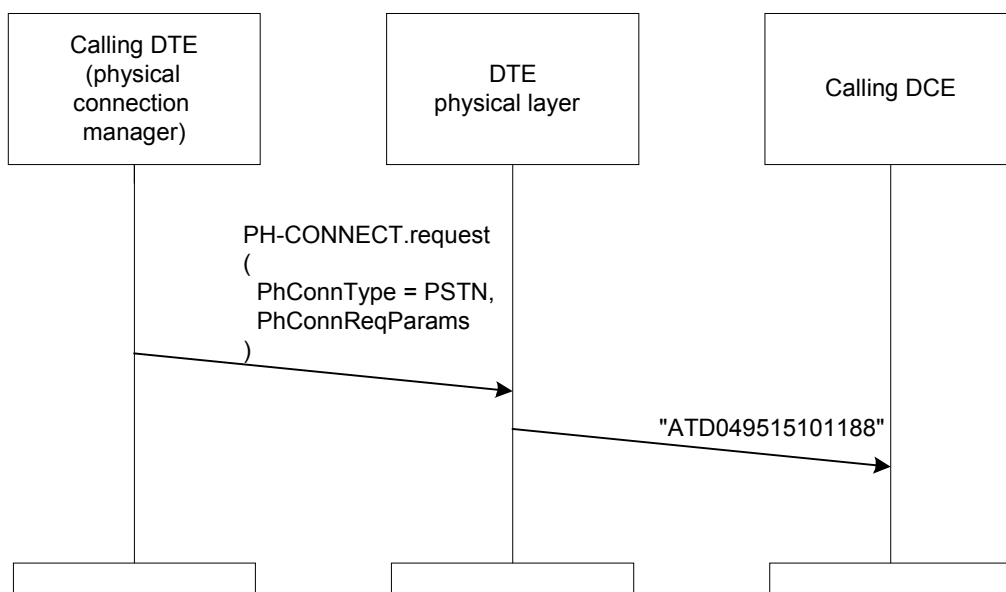

IEC 242/02

Figure A.1 – MSC for physical connection request

As it is shown, the physical layer extracts the telephone number from the PhConnReqParams service parameter, and sends it as a series of ASCII characters headed by the "ATD" Hayes command identifier to the DCE. No more action is required in the physical layer – off hook the line, dialling and analyzing the result is done by the DCE in an autonomous way (that is why this type of modem is called 'intelligent'). The physical layer simply waits the result of the command execution – which is sent back by the DCE in the form of a Hayes message, as it is shown in Figure A.2.

A.2.2 PH-CONNECT.confirm

When the DCE is in ASCII mode, it generates one of the following messages after trying to dial the previously received phone number:

CONNECT: indicates that the connection has been established successfully. After issuing the connect message, the DCE switches to the data transmission mode.

ERROR: indicates a general error or an invalid dial command.

NO DIALTONE: indicates that there was no dial tone detected within the given timeout period.

NO CARRIER: indicates that the connection has not been established because there was no carrier detected from the remote DCE.

BUSY: indicates that the connection has not been established because the remote DCE is busy.

When the physical layer receives any of these messages, it generates a PH-CONNECT.confirm service primitive with the correct service parameters to the service user, the physical connection manager application process.

Figure A.2 shows the complete message sequence at the CALLING station in case of successful physical connection establishment.

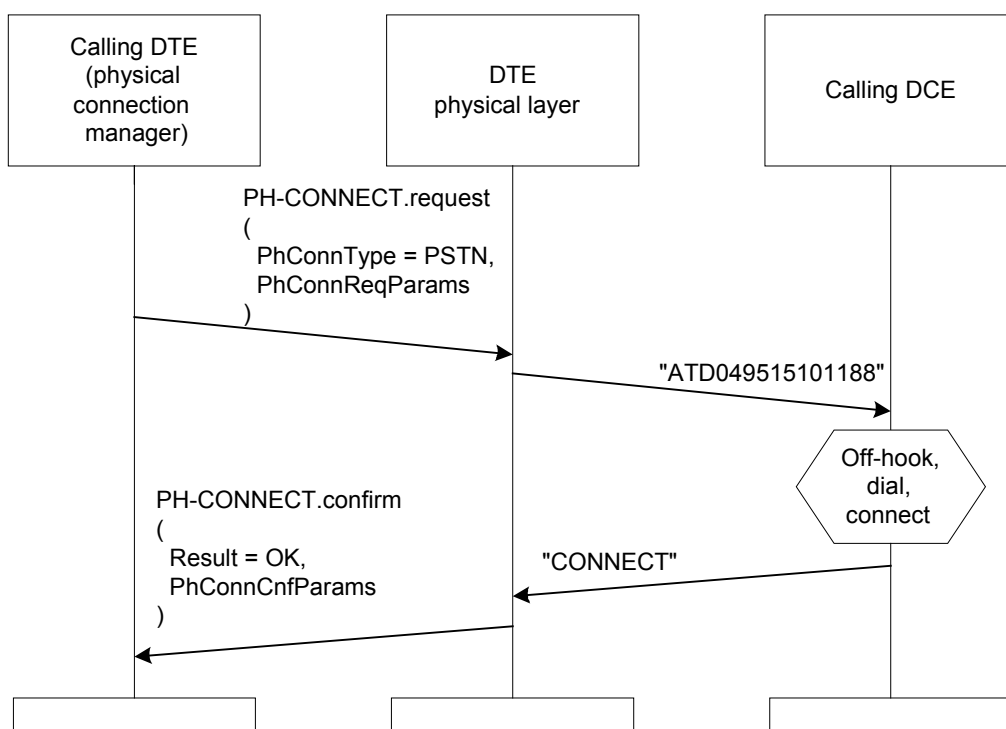

IEC 243/02

Figure A.2 – Physical connection establishment at the CALLING station

A.2.3 PH-CONNECT.indication

A DCE indicates an incoming call by issuing the RING message to the DTE. If the DCE was switched to the AutoAnswer mode during the initialize procedure, it does not send RING messages, but tries to establish the connection automatically after detecting the specified number of ring signals.

If the auto answer mode is disabled, the PH entity can decide whether to pick up the phone by using the "ATA" command or not. This may be applicable if the server maintains time windows to answer the phone.

Messages to the DTE:

RING: Indicates an incoming call.

Commands to the DCE:

ATA: Answer the incoming call.

In both cases, the DCE signals the result in the same way as it was discussed at PH-CONNECT.confirm.

A simplified message sequence of a complete physical connection establishment is shown in Figure A.3, when the DCE is not working in AutoAnswer mode.

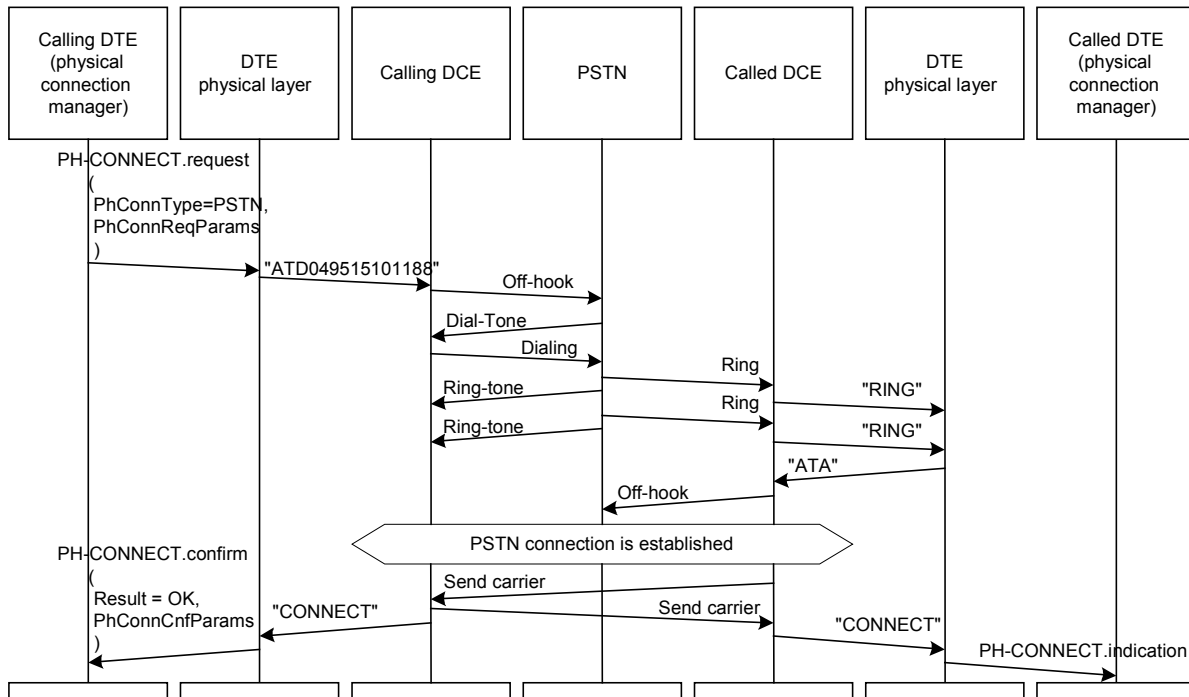

IEC 244/02

Figure A.3 – MSC for physical connection establishment

A.2.4 PH-DATA.request / .indication

Assuming that a connection with a remote DCE was established before and that the DCE is in data transmission mode now, all data passed to the local DCE will be transmitted to the remote DCE.

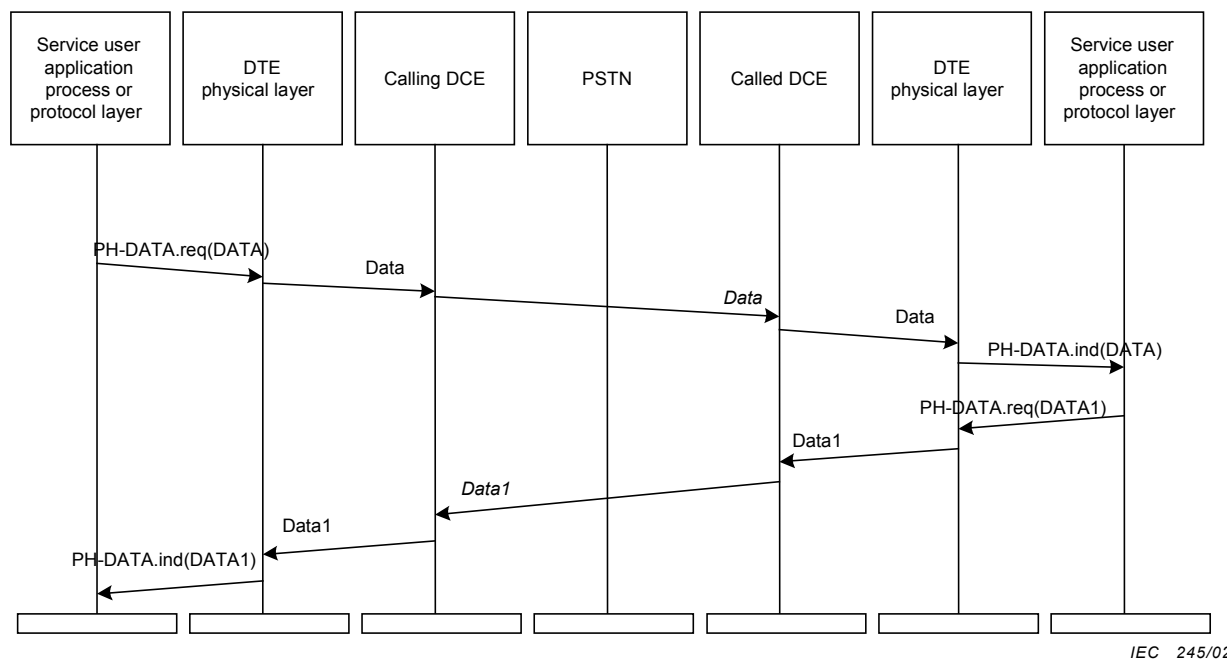

Figure A.4 – Data exchange between the calling and called stations

Please note that there is a difference between the actual data formats:

- “DATA/(DATA1)”, the service parameter of the data communication services DATA.request/indicate is specified in 6.1 as one byte.
- “Data/(Data1)” is a frame containing the data with some additional bits for the asynchronous transmission (start and stop bit).
- “Data/(Data1)”, the information exchanged between the two DCEs might contain even more bits for the purpose of error detection/correction functions) and/or could be encoded for the data transmission purposes.

A.2.5 PH-ABORT.request /confirm

Before the connection can be terminated, the modem has to be switched to local command mode first.

For this purpose, the Hayes environment provides an escape sequence defined as:

- 1 second idle state (no data transmission);
- sending 3 plus "+++" characters;
- 1 second idle state again.

The DCE confirms the command mode with an **OK** message (but the connection is still valid).

The connection can be terminated now using the OnHook **"ATH"** command.

Messages to the DTE:

OK: DCE is in command mode again.

Commands to the DCE:

ATH: terminate the connection (OnHook)

If the OnHook command was successful, the DCE responds with the NO_CARRIER message, otherwise an ERROR message is returned.

NO_CARRIER: connection was successfully aborted.

ERROR: the OnHook command failed, connection is still available.

A.2.6 PH-ABORT.indication

If the carrier is lost, the local DCE issues the "NO_CARRIER" message. The DTE is not able to determine the reasons for losing the carrier; one of the reasons can be that the remote DTE terminated the connection.

Once the physical layer has received this message, it should use the PH-ABORT.indication service primitive to indicate the termination of the connection.

NO_CARRIER: connection was aborted by the remote DCE or due an error condition.

Figure A.5 shows an example for physical disconnection.

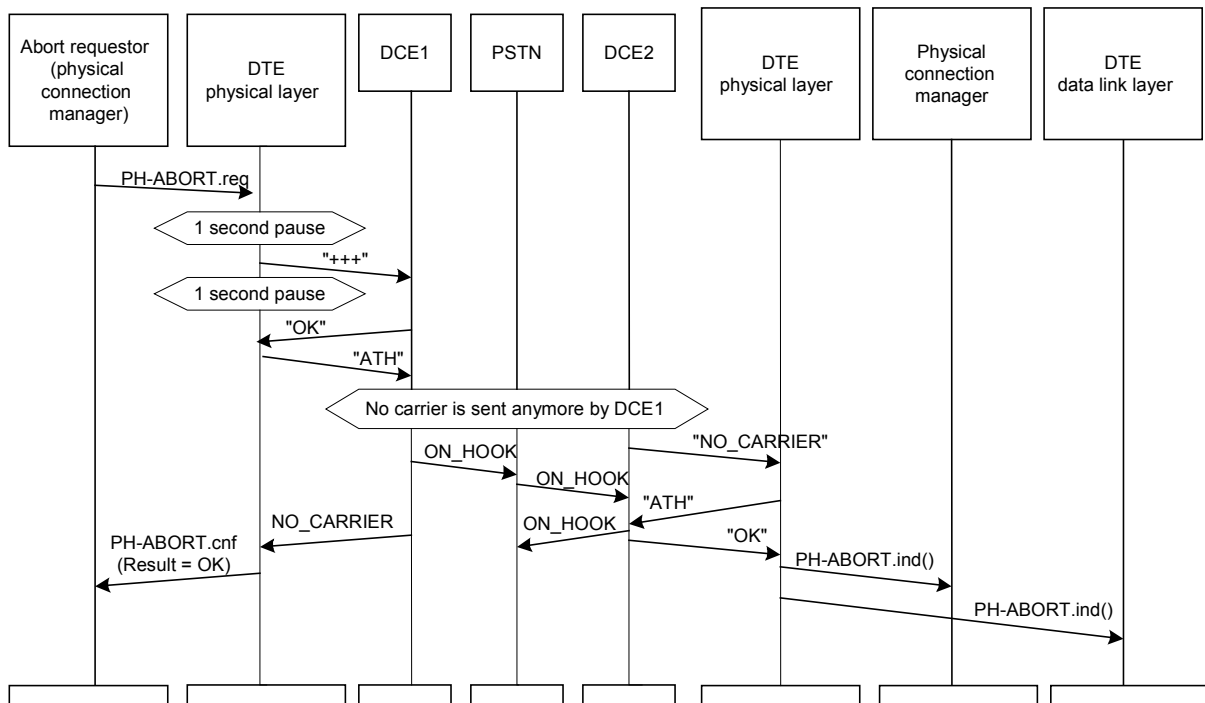

IEC 246/02

Figure A.5 – MSC for a physical disconnection

Annex B (informative)

Data model and protocol

The data model uses generic building blocks to define the complex functionality of the metering equipment. It provides a view of this functionality of the meter as it is available at its interface(s). The model does not cover internal, implementation-specific issues.

The communication protocol defines how the data can be accessed and exchanged.

This is illustrated in Figure B.1 below:

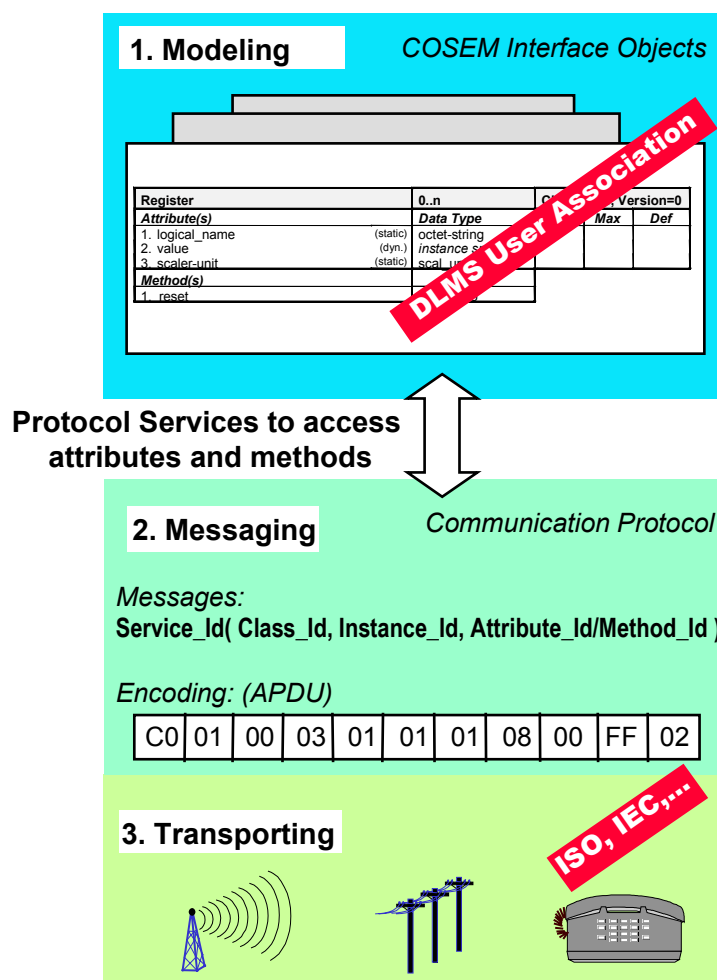

IEC 247/02

Figure B.1 – The three-step approach of COSEM

- The COSEM specification details metering domain specific interface classes. The functionality of the meter is defined by the instances of these interface classes, called COSEM objects. This is defined in IEC 62056-62. Logical names, identifying the COSEM objects are defined in IEC 62056-61.
- The attributes and methods of these COSEM objects can be accessed and used via the messaging services of the application layer.
- The lower layers of the protocol transport the information.

Bibliography

IEC 62056-41:1998, *Electricity metering – Data exchange for meter reading, tariff and load control – Part 41: Data exchange using wide area networks: Public switched telephone network (PSTN) with LINK+ protocol*

IEC 61334-4-41:1996, *Distribution automation using distribution line carrier systems – Part 4: Data communication protocols – Section 41: Application protocols – Distribution line message specification*

IEC 61334-6:2000, *Distribution automation using distribution line carrier systems – Part 6: A-XDR encoding rule*

ISO 2110:1989, *Information technology – Data communication – 25-pole DTE/DCE interface connector and contact number assignments*

ITU-T V.24:2000, *List of definitions for interchange circuits between data terminal equipment (DTE) and data circuit-terminating equipment (DCE)*

ITU-T V.25:1996, *Automatic answering equipment and general procedures for automatic calling equipment on the general switched telephone network*

ITU-T V.25bis:1996, *Synchronous and asynchronous automatic dialling procedures on switched networks*

ITU-T V.28:1993, *Electrical characteristics for unbalanced double-current interchange circuits*

ITU-T X.211:1995, *Information technology – Open Systems Interconnection – Physical service definition*

Index

abbreviations	6	OK.....	23
ATA	22	Overview	7
ATH	23	Partial state machine	18
BUSY.....	21	PH-ABORT.confirm	11
client.....	6	PH-ABORT.indication	11, 24
Client side	18	PH-ABORT.request	11
CONNECT	21	PH-ABORT.request / .confirm	23
Connection establishment.....	8	PH-CONNECT.confirm	10, 21
COSEM	6	PH-CONNECT.indication	10, 22
Data communication services.....	8	PH-CONNECT.request	9, 20
Data Communications	19	PH-DATA.indication.....	12
Data model	25	PH-DATA.request.....	12
DCE.....	6	PH-DATA.request / .indication	22
definitions	6	PH-Layer service primitives and Hayes command set.....	20
description of the procedures.....	13	Physical layer operation	13
Disconnection of an existing Physical Connection	19	Physical Layer Protocol Data Unit.....	13
ERROR.....	21, 24	physical layer services	9
Identification Service	17	Physical layer services	20
Identification Service message specification	15	Protocol Data Unit	13
Identification service protocol specification	17	Protocol Specification.....	13
Identify.request.....	15	release related services.....	8
Identify.response	16	RING	22
Layer management services	8	server.....	6
List of services.....	8	Server side.....	17
master	6	Service definitions	9
message exchanges	20	Service Specification	8
NO CARRIER	21	Setting up a physical connection	14
NO DIALTONE.....	21	slave	6
NO_CARRIER.....	24	Terms.....	6
Normative references.....	5	The Identification Service	15
		Transmission order and characteristics...	13

Annex ZA (normative)

Normative references to international publications with their corresponding European publications

This European Standard incorporates by dated or undated reference, provisions from other publications. These normative references are cited at the appropriate places in the text and the publications are listed hereafter. For dated references, subsequent amendments to or revisions of any of these publications apply to this European Standard only when incorporated in it by amendment or revision. For undated references the latest edition of the publication referred to applies (including amendments).

NOTE When an international publication has been modified by common modifications, indicated by (mod), the relevant EN/HD applies.

<u>Publication</u>	<u>Year</u>	<u>Title</u>	<u>EN/HD</u>	<u>Year</u>
IEC 60050-300	2001	International Electrotechnical Vocabulary - Electrical and electronic measurements and measuring instruments Part 311: General terms relating to measurements Part 312: General terms relating to electrical measurements Part 313: Types of electrical measuring instruments Part 314: Specific terms according to the type of instrument	-	-
IEC/TR 62051	1999	Electricity metering - Glossary of terms	-	-
IEC 62056-21	2002	Electricity metering - Data exchange for meter reading, tariff and load control Part 21: Direct local data exchange	EN 62056-21	2002
IEC 62056-46	2002	Part 46: Data link layer using HDLC protocol	EN 62056-46	2002
IEC 62056-53	2002	Part 53: COSEM application layer	EN 62056-53	2002
IEC 62056-61	2002	Part 61: Object identification system (OBIS)	EN 62056-61	2002
IEC 62056-62	2002	Part 62: Interface classes	EN 62056-62	2002
NEMA C12.21	1999	Protocol Specification for Telephone Modem Communication	-	-

BSI — British Standards Institution

BSI is the independent national body responsible for preparing British Standards. It presents the UK view on standards in Europe and at the international level. It is incorporated by Royal Charter.

Revisions

British Standards are updated by amendment or revision. Users of British Standards should make sure that they possess the latest amendments or editions.

It is the constant aim of BSI to improve the quality of our products and services. We would be grateful if anyone finding an inaccuracy or ambiguity while using this British Standard would inform the Secretary of the technical committee responsible, the identity of which can be found on the inside front cover.
Tel: +44 (0)20 8996 9000. Fax: +44 (0)20 8996 7400.

BSI offers members an individual updating service called PLUS which ensures that subscribers automatically receive the latest editions of standards.

Buying standards

Orders for all BSI, international and foreign standards publications should be addressed to Customer Services. Tel: +44 (0)20 8996 9001.
Fax: +44 (0)20 8996 7001. Email: orders@bsi-global.com. Standards are also available from the BSI website at <http://www.bsi-global.com>.

In response to orders for international standards, it is BSI policy to supply the BSI implementation of those that have been published as British Standards, unless otherwise requested.

Information on standards

BSI provides a wide range of information on national, European and international standards through its Library and its Technical Help to Exporters Service. Various BSI electronic information services are also available which give details on all its products and services. Contact the Information Centre.
Tel: +44 (0)20 8996 7111. Fax: +44 (0)20 8996 7048. Email: info@bsi-global.com.

Subscribing members of BSI are kept up to date with standards developments and receive substantial discounts on the purchase price of standards. For details of these and other benefits contact Membership Administration.
Tel: +44 (0)20 8996 7002. Fax: +44 (0)20 8996 7001.
Email: membership@bsi-global.com.

Information regarding online access to British Standards via British Standards Online can be found at <http://www.bsi-global.com/bsonline>.

Further information about BSI is available on the BSI website at <http://www.bsi-global.com>.

Copyright

Copyright subsists in all BSI publications. BSI also holds the copyright, in the UK, of the publications of the international standardization bodies. Except as permitted under the Copyright, Designs and Patents Act 1988 no extract may be reproduced, stored in a retrieval system or transmitted in any form or by any means – electronic, photocopying, recording or otherwise – without prior written permission from BSI.

This does not preclude the free use, in the course of implementing the standard, of necessary details such as symbols, and size, type or grade designations. If these details are to be used for any other purpose than implementation then the prior written permission of BSI must be obtained.

Details and advice can be obtained from the Copyright & Licensing Manager.
Tel: +44 (0)20 8996 7070. Fax: +44 (0)20 8996 7553.
Email: copyright@bsi-global.com.