

BS EN 62037-1:2012



BSI Standards Publication

# Passive RF and microwave devices, intermodulation level measurement

Part 1: General requirements and measuring methods

**bsi.**

...making excellence a habit.™

### National foreword

This British Standard is the UK implementation of EN 62037-1:2012. It is identical to IEC 62037-1:2012. Together with BS EN 62037-2:2013, BS EN 62037-3:2012, BS EN 62037-4:2012, BS EN 62037-5:2013 and BS EN 62037-6:2013, it supersedes BS EN 62037:2000 which will be withdrawn on 15 July 2015.

The UK participation in its preparation was entrusted to Technical Committee EPL/46, Cables, wires and waveguides, radio frequency connectors and accessories for communication and signalling.

A list of organizations represented on this committee can be obtained on request to its secretary.

This publication does not purport to include all the necessary provisions of a contract. Users are responsible for its correct application.

© The British Standards Institution 2013

Published by BSI Standards Limited 2013

ISBN 978 0 580 58416 9

ICS 33.120.30

**Compliance with a British Standard cannot confer immunity from legal obligations.**

This British Standard was published under the authority of the Standards Policy and Strategy Committee on 30 April 2013.

### Amendments issued since publication

Amd. No.	Date	Text affected
----------	------	---------------

---

English version

**Passive RF and microwave devices, intermodulation level measurement -  
Part 1: General requirements and measuring methods  
(IEC 62037-1:2012)**

Dispositifs RF et à micro-ondes passifs,  
mesure du niveau d'intermodulation -  
Partie 1: Exigences générales  
et méthodes de mesure  
(CEI 62037-1:2012)

Passive HF- und Mikrowellenbauteile,  
Messung des Intermodulationspegels -  
Teil 1: Allgemeine Anforderungen  
und Messverfahren  
(IEC 62037-1:2012)

This European Standard was approved by CENELEC on 2012-07-03. CENELEC members are bound to comply with the CEN/CENELEC Internal Regulations which stipulate the conditions for giving this European Standard the status of a national standard without any alteration.

Up-to-date lists and bibliographical references concerning such national standards may be obtained on application to the CEN-CENELEC Management Centre or to any CENELEC member.

This European Standard exists in three official versions (English, French, German). A version in any other language made by translation under the responsibility of a CENELEC member into its own language and notified to the CEN-CENELEC Management Centre has the same status as the official versions.

CENELEC members are the national electrotechnical committees of Austria, Belgium, Bulgaria, Croatia, Cyprus, the Czech Republic, Denmark, Estonia, Finland, Former Yugoslav Republic of Macedonia, France, Germany, Greece, Hungary, Iceland, Ireland, Italy, Latvia, Lithuania, Luxembourg, Malta, the Netherlands, Norway, Poland, Portugal, Romania, Slovakia, Slovenia, Spain, Sweden, Switzerland, Turkey and the United Kingdom.

**CENELEC**

European Committee for Electrotechnical Standardization  
Comité Européen de Normalisation Electrotechnique  
Europäisches Komitee für Elektrotechnische Normung

**Management Centre: Avenue Marnix 17, B - 1000 Brussels**

## Foreword

The text of document 46/402/FDIS, future edition 1 of IEC 62037-1, prepared by IEC TC 46 "Cables, wires, waveguides, R.F. connectors, R.F. and microwave passive components and accessories" was submitted to the IEC-CENELEC parallel vote and approved by CENELEC as EN 62037-1:2012.

The following dates are fixed:

- latest date by which the document has to be implemented at national level by publication of an identical national standard or by endorsement (dop) 2013-04-03
- latest date by which the national standards conflicting with the document have to be withdrawn (dow) 2015-07-03

This document supersedes EN 62037:1999 (PART).

Attention is drawn to the possibility that some of the elements of this document may be the subject of patent rights. CENELEC [and/or CEN] shall not be held responsible for identifying any or all such patent rights.

## Endorsement notice

The text of the International Standard IEC 62037-1:2012 was approved by CENELEC as a European Standard without any modification.

## CONTENTS

1	Scope.....	5
2	Normative references.....	5
3	Abbreviations.....	5
4	Characteristics of intermodulation products.....	5
5	Principle of test procedure.....	6
6	Test set-up.....	6
6.1	General.....	6
6.2	Test equipment.....	6
6.2.1	General.....	6
6.2.2	Set-up 1.....	7
6.2.3	Set-up 2.....	8
7	Preparation of DUT and test equipment.....	8
7.1	General.....	8
7.2	Guidelines for minimizing generation of passive intermodulation.....	8
8	Test procedure.....	10
9	Reporting.....	10
9.1	Results.....	10
9.2	Example of results.....	10
10	Measurement error.....	11
	Annex A (informative) Configuration of low-PIM termination.....	15
	Annex B (informative) Test procedure considerations.....	17
	Figure 1 – Set-up 1; reverse IM-test set-up.....	12
	Figure 2 – Set-up 2; forward IM-test set-up.....	13
	Figure 3 – Passive intermodulation (PIM) measurement error caused by residual system error.....	14
	Figure A.1 – Long cable termination.....	15
	Figure A.2 – Lumped termination with a linear attenuator.....	16
	Table 1 – Guide for the design, selection of materials and handling of components that may be susceptible to PIM generation.....	9
	Table 2 – Test set-up conditions.....	10

## **PASSIVE RF AND MICROWAVE DEVICES, INTERMODULATION LEVEL MEASUREMENT –**

### **Part 1: General requirements and measuring methods**

#### **1 Scope**

This part of IEC 62037 deals with the general requirements and measuring methods for intermodulation (IM) level measurement of passive RF and microwave components, which can be caused by the presence of two or more transmitting signals.

The test procedures given in this standard give the general requirements and measurement methods required to characterize the level of unwanted IM signals using two transmitting signals.

The standards in this series address the measurement of PIM, but do not cover the long term reliability of a product with reference to its performance.

This standard is to be used in conjunction with other appropriate part(s) of IEC 62037.

#### **2 Normative references**

None.

#### **3 Abbreviations**

CATV Community antenna television

DUT Device under test

IM Intermodulation

PIM Passive intermodulation

#### **4 Characteristics of intermodulation products**

PIM interference is caused by sources of non-linearity of mostly unknown nature, location and behaviour. A few examples are inter-metallic contacts, choice of materials, corrosion products, dirt, etc. Most of these effects are subject to changes over time due to mechanical stress, temperature changes, variations in material characteristics (cold flow, etc.) and climatic changes, etc.

The generation of intermodulation products originates from point-sources inside a DUT and propagate equally in all available directions.

The generation of passive intermodulation products (PIM) does not necessarily follow the law of the usual non-linear equation of quadratic form. Therefore, accurate calculation to other power levels causing the intermodulation is not possible and PIM comparisons should be made at the same power level.

Furthermore, PIM generation can be frequency-dependent. When PIM generation is frequency-dependant, the PIM performance shall be investigated over the specified frequency band.

## 5 Principle of test procedure

Test signals of frequencies  $f_1$  and  $f_2$  with equal specified test port power levels are combined and fed to the DUT. The test signals should contain at least 10 dB less harmonic or self-intermodulation signal level than the expected level generated in the DUT.

The PIM is measured over the specified frequency range. The intermodulation products of order  $(2f_1 \pm f_2)$ ,  $(2f_2 \pm f_1)$  etc. are measured.

In most cases, the third order intermodulation signals represent the worst case condition of unwanted signals generated; therefore, the measurement of these signals characterizes the DUT in a sufficient way. However, the test set-ups given in Clause 6 are suitable for measuring other intermodulation products.

In other systems (such as CATV), the 3<sup>rd</sup> order may not be as applicable in characterizing the DUT.

Intermodulation can be measured in reverse and forward direction. Reverse and forward is referred to the direction of propagation of the most powerful carrier.

## 6 Test set-up

### 6.1 General

Experience shows that the generation of intermodulation products originates from point-sources inside a device under test (DUT) and propagates equally in all available directions. Therefore, either the reverse (reflected) or the forward (transmitted) intermodulation signal can be measured.

Two different test set-ups are described in Figure 1 and Figure 2 and are for reference only. Other topologies are possible.

Set-up 1 is for measuring the reverse (reflected) intermodulation signal only, and set-up 2 is for measuring the forward (transmitted) intermodulation signal. The measurement method (reverse or forward) is dependent upon the DUT. The set-ups may be assembled from standard microwave or radio link hardware selected for this particular application. All components shall be checked for lowest self-intermodulation generation.

Experience shows that devices containing magnetic materials (circulators, isolators, etc.) can be prominent sources of intermodulation signal generation.

See Annex B for additional set-up considerations.

### 6.2 Test equipment

#### 6.2.1 General

Two signal sources or signal generators with power amplifiers are required to reach the specified test port power. The combining and diplexing device may comprise a circulator, hybrid junction, coupler or filter network.

The test set-up self-intermodulation generated (including contribution of the load) should be at least 10 dB below the level to be measured on the DUT. The associated error may be obtained from the graph in Figure 3.

The DUT shall be terminated by a load for the specified power if necessary. The receiving bandpass filter, tuned for the desired intermodulation signal, is followed by a low noise amplifier (if required) and a receiver.

See Annex B for additional set-up considerations.

### 6.2.2 Set-up 1

This set-up is to measure the reverse (reflected) IM-product and is therefore suitable for 1-port and multi-port DUTs. On multi-port DUTs, the unused ports shall be connected to a linear termination.

a) Generators

The generators shall provide continuous wave (CW) signals of the specified test port power. They shall have sufficient frequency stability to make sure that the IM-product can be detected properly by the receiver.

b) Transmit-filters

The filters are bandpass-filters tuned to the particular frequencies. They isolate the generators from each other and filter out the harmonics of  $f_1$  and  $f_2$ .

c) Combining and diplexing device

This device is used for combining the signals  $f_1$  and  $f_2$ , delivering them to the test port and provides a port for the extraction of the reverse (reflected) signal  $f_{IM}$ .

d) Receive-filter

This filter is used for isolating the input of the receiver from the signals  $f_1$  and  $f_2$  to the extent that IM-products are not generated within the receiver.

e) Test port

The DUT is connected to P4. The specified input power shall be at the DUT, with any set-up loss between the receiver and the DUT compensated for.

f) Termination

When a multi-port DUT is measured, the DUT shall be connected to a sufficiently linear termination (low intermodulation) of suitable power handling capability.

g) Receiver

The receiver shall be sensitive enough to detect a signal of the expected power level.

The receiver response time shall be sufficiently short to allow acquisition of rapid changes in amplitude. Sensitivity can be increased by a low noise preamplifier. Frequency stability shall be sufficient for the proper detection of the IM-signal.

When the PIM measurement result is close to the thermal noise floor of the receiver, the receiver sensitivity can be improved by reducing the resolution bandwidth (RBW). Furthermore, by using the averaging mode rather than the max-hold mode, a further improvement can be achieved, since the max-hold mode essentially measures the maximum thermal noise peak, while the averaging mode results in a measurement that is closer to the r.m.s. value.



### 6.2.3 Set-up 2

This set-up is to measure the forward (transmitted) IM-product and is therefore suitable only for two- or multi-port DUTs.

All components are the same as those of set-up 1, except for those as noted below:

a) Combining and diplexing device

The extraction-port P3 on this device shall be terminated to prevent reflection of the IM-signals.

b) Diplexing device

The signals  $f_1$ ,  $f_2$  and  $f_{IM}$  are split to P6 and P7. This device, together with an additional receive-filter, is used for the extraction of the intermodulation signals.

## 7 Preparation of DUT and test equipment

### 7.1 General

The DUT and test equipment shall be carefully checked for proper power handling range, frequency range, cleanliness and correct interconnection dimensions. All connector interfaces shall be tightened to the applicable IEC specification or, if none exists, to the manufacturer's recommended specification.

See Annex B for additional set-up considerations.

### 7.2 Guidelines for minimizing generation of passive intermodulation

The following guidelines and Table 1 should be considered and adhered to wherever possible.

- a) Non-linear materials should not be used in or near the current paths.
- b) Current densities should be minimized in the conduction paths (e.g. Tx channel), by using larger conductors.
- c) Minimize metallic junctions, avoid loose contacts and rotating joints.
- d) Minimize the exposure of loose contacts, rough surfaces and sharp edges to RF power.
- e) Keep thermal variations to a minimum, as the expansion and contraction of metals can create non-linear contacts.
- f) Use brazed, soldered or welded joints if possible – but ensure these joints are good and have no non-linear materials, cracks, contamination or corrosion.
- g) Avoid having tuning screws or moving parts in the high current paths – if necessary, then ensure all joints are tight and clean, and preferably, free from vibration.
- h) Cable lengths in general should be minimized and the use of high quality, low-IM cable is essential.
- i) Minimize the use of non-linear components such as high-PIM loads, circulators, isolators and semiconductor devices.
- j) Achieve good isolation between the high-power transmit signals and the low-power receive signals by filtering and physical separation.

**Table 1 – Guide for the design, selection of materials and handling of components that may be susceptible to PIM generation**

Part, material or procedure	Recommendations
Interfaces	Minimize the total number.
Connectors	Minimize the number of connectors used. Use high quality, low-PIM connectors mated with proper torque.
Inter-metallic connections	Each inter-metallic connection should be evaluated in terms of criticality for the total PIM level. Methods of controlling the performance are high contact pressure, insulation, soldering, brazing, etc.
Ferromagnetic materials	Not recommended (non-linear).
Non-magnetic stainless steel	Not recommended (contains iron).
Circulators, isolators and other ferrite devices	Not recommended.
Sharp edges	Avoid if it results in high current density.
Terminations or attenuators	Should be evaluated before use.
Hermetic seals / gaskets	Evaluate before use and avoid ferromagnetic materials.
Printed circuit boards (PCB)	Materials, processes and design should all be considered and evaluated. Use low-PIM materials; be careful with material impurities, contamination and etching residuals. The copper trace should be finished to prevent corrosion.
Dissimilar metals	Not recommended (risk of galvanic corrosion).
Dielectric material	Use clean, high quality material. Ensure it does not contain electrically conductive particles.
Machined dielectric materials	Use clean non-contaminated tools for machining.
Welded, soldered or brazed joint	Well executed and thoroughly cleaned, they provide satisfactory results. Shall be carefully inspected.
Carbon fibre epoxy composite (CFEC)	Generally acceptable for use in reflector and support structures, provided the fibres are not damaged. Should be evaluated if high flux density (e.g. >10 mW/cm <sup>2</sup> is expected).
Standard multilayer thermal blankets made of Vacuum Deposited Aluminium (VDA) on biaxially-oriented polyethylene terephthalate film or Polyimide film	Special design required.
Cleanliness	Maintain clean and dry surfaces.
Plating	The thickness of the plating should be at least three times greater than the skin depth of the wave resulting from the skin effect at the lowest relevant frequency.

## 8 Test procedure

Table 2 gives certain conditions for test set-up 1 and test set-up 2.

**Table 2 – Test set-up conditions**

Test set-up 1	Test set-up 2
The set-up shall be verified for correct signal levels applied to the DUT. For mobile communication systems, it is generally recommended to use $2 \times 20$ W (43 dBm) at the test port of the DUT, unless otherwise specified. Other systems may require different power levels.	
The minimum number of test frequencies and/or frequency spacing shall be specified.	
For lowest measurement uncertainty, the receiver shall be calibrated at the expected IM-level with a calibrated signal-source as indicated in Figure 1 and Figure 2.	
The termination shall be connected directly to the test port P4 and the self-intermodulation level of the set-up recorded.	P5 of diplexing device shall be connected directly to P4 of combining and summing device and the self-intermodulation level of the set-up recorded.
For low measurement uncertainties, the level of self-intermodulation should be at least 10 dB below the specified value for the DUT.	
Test the DUT as given in the specific set-up and procedure in the appropriate test set-up.	
An additional mechanical shock test may be carried out during the test sequence.	

## 9 Reporting

### 9.1 Results

The input power at individual frequencies should be specified.

The values of  $f_1$  and  $f_2$  should be specified.

The PIM level and frequency should be specified.

### 9.2 Example of results

The result is expressed as an absolute magnitude in dBm or relative magnitude in dBc, referenced to the power of a single carrier.

The relationship between a measured  $IM_3$ -value of  $-120$  dBm can be converted to dBc as follows:

EXAMPLE:

$$f_1 = 936 \text{ MHz}, f_2 = 958 \text{ MHz}, f_{IM_3} = 914 \text{ MHz}$$

$$P(f_1) = P(f_2) = 20 \text{ W (+43 dBm)}$$

$$IM_3 = -163 \text{ dBc (-120 dBm)}$$

## 10 Measurement error

The measurement uncertainty can be calculated by the following formula:

$$RSS = \sqrt{[(\delta A)^2 + (\delta P_m)^2 + (\delta P_g)^2 + (\delta D)^2]}$$

where

$\delta A$  is the uncertainty of attenuator;

$\delta P_m$  is the uncertainty of power meter;

$\delta P_g$  is the uncertainty of generator 3;

$\delta D$  is the uncertainty due to the difference between self-intermodulation of the test bench and intermodulation of the DUT (taken from Figure 3).

Mismatch errors are not included in the given formula.

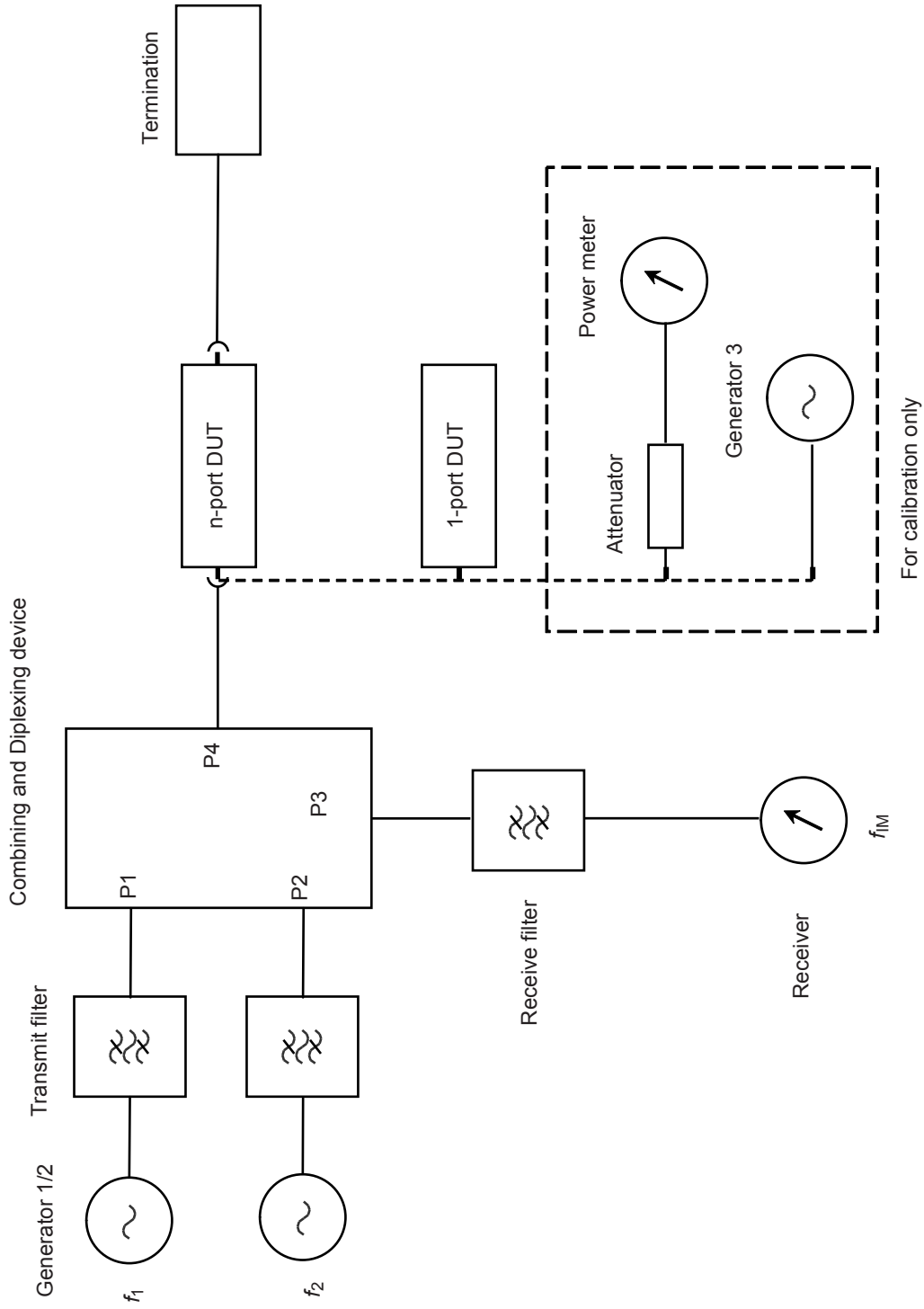

IEC 948/12

Figure 1 – Set-up 1; reverse IM-test set-up

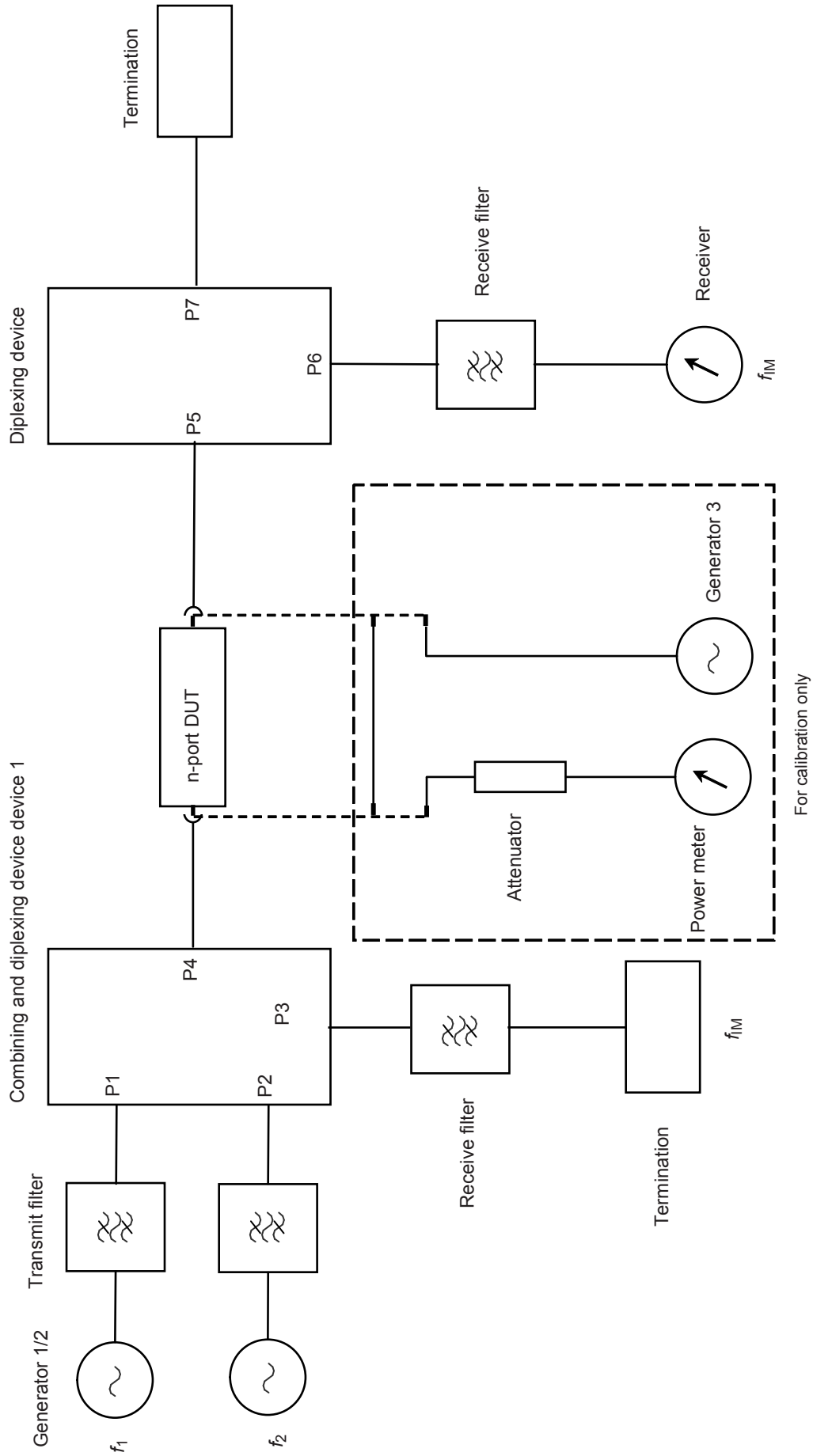

IEC 949/12

Figure 2 – Set-up 2; forward IM-test set-up

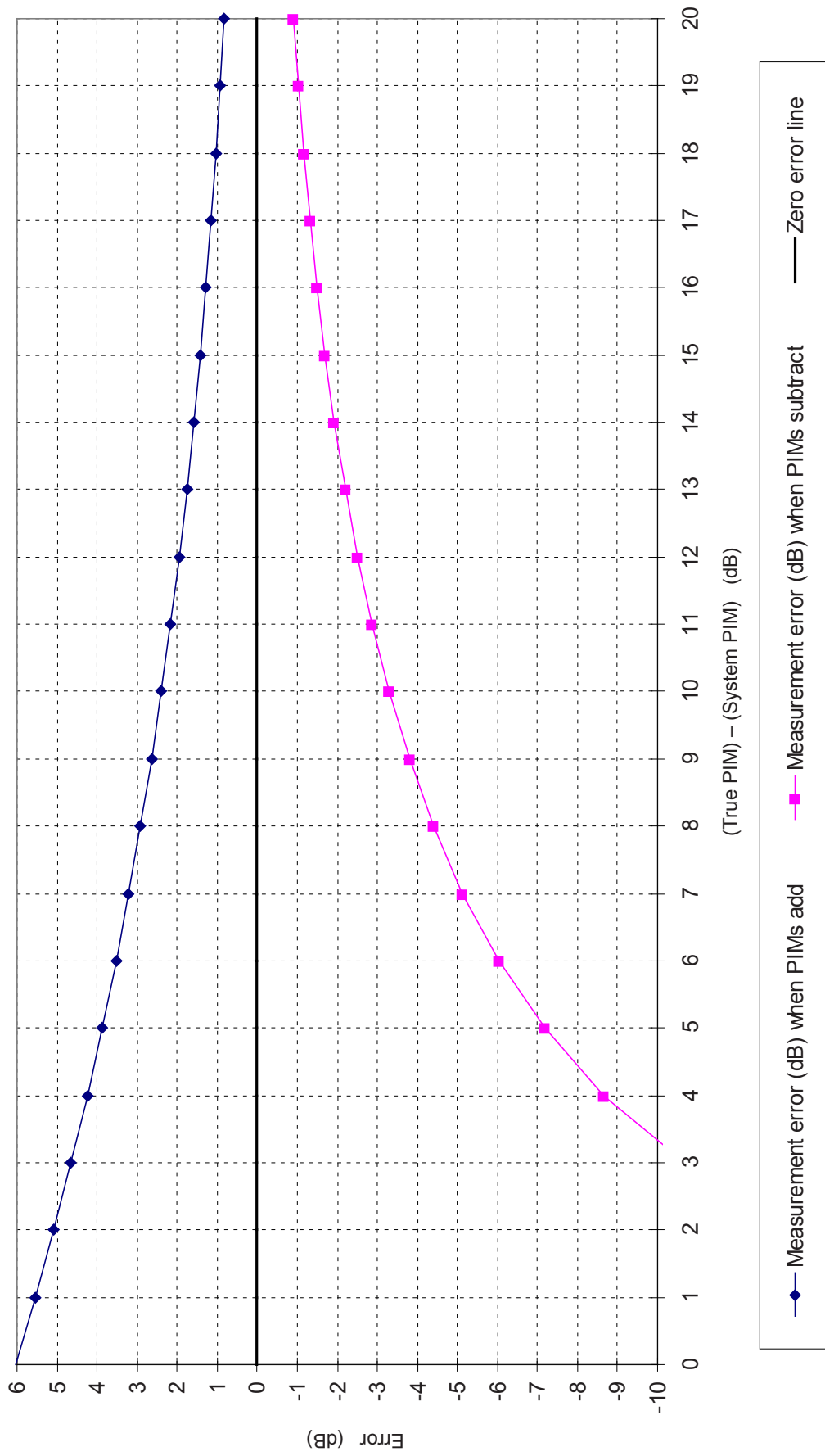

IEC 950/12

Figure 3 – Passive intermodulation (PIM) measurement error caused by residual system error

## Annex A (informative)

### Configuration of low-PIM termination

#### A.1 General

This annex provides information on low-PIM terminations.

#### A.2 Configuration of low-PIM terminations

##### A.2.1 Long cable termination

High-PIM terminations may often consist of resistive materials. Therefore, long coaxial cables are used as a low-PIM termination (see Figure A.1). The following guidelines are in no particular order of significance, but should be considered and adhered to wherever possible.

- a) Avoid braided cables. Cables with a single centre conductor should be used. Semi-rigid cables would be a good choice from the practical viewpoint.
- b) Avoid using cables with high-PIM materials and high-PIM plating. Plating with silver and tin would be a good choice. Plating should be sufficiently thicker than the skin depth at the lowest fundamental frequency.
- c) A seamless cable configuration is the best for terminations because minimizing cable-connection is essential to achieve low-PIM. When the termination is composed of several short cables, the longest one should be used at the nearest side to the DUT.
- d) Choose the cable with sufficient power-handling capability.
- e) Choose the cable length sufficient for power absorption at the lowest fundamental frequency considering the isolation performance between the receive signals and transmit signals.
- f) Use a connector with low-PIM characteristics.

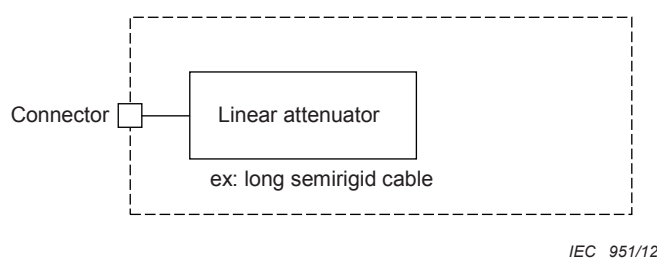

Figure A.1 – Long cable termination

##### A.2.2 Lumped termination with a linear attenuator

Low-PIM cable can be considered as a linear attenuator. The combination of the linear attenuator and a high-PIM lumped load as shown in Figure A.2 may be used as a low-PIM termination. The following procedure is presented for designing a low-PIM termination.

- 1) Measure the PIM characteristics of the lumped termination as a function of the fundamental power, and determine the PIM-increase ratio  $X$ [dB].
- 2) Determine the required attenuation of the linear attenuator  $X_c$ [dB] using the formula:

$$PIM_{\text{term}} = PIM_{\text{RDL}} - (X + 1)X_c$$



- 3) Design the required length of the cable for the linear attenuator using the following formula:

$$X_c = \alpha \times l_m$$

where

$PIM_{RDL}$  is the PIM of the lumped termination for  $P_{in}$ , in dBm;

$PIM_{term}$  is the PIM level required for the low-PIM termination in dBm;

$X$  is the PIM increase against the 1 dB-increase of each input tone, in dB;

$X_c$  is the attenuation of the linear attenuator, in dB;

$\alpha$  is the attenuation ratio of the cable, in dB/m;

$l_m$  is the cable length, in m.

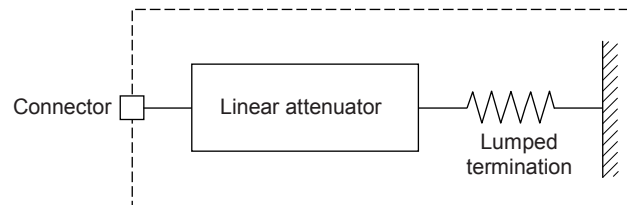

IEC 952/12

**Figure A.2 – Lumped termination with a linear attenuator**

## **Annex B** (informative)

### **Test procedure considerations**

#### **B.1 General**

Due to the phase interaction of the connectors and the length of the transmission line when measured in the reverse (reflected) mode, the frequency at which maximum PIM occurs within the band can vary and shall be determined.

#### **B.2 Stepped frequency sweep**

An accepted method of sweeping is to fix F1 at the low end of the transmit band and step F2 down, starting at the top of the band for all combination of frequencies that result in IM in the receive band. If desired, this procedure can be reversed by fixing F1 at the highest frequency in the transmit band and then stepping F2 up, starting at the bottom of the band.

#### **B.3 Fixed frequency**

Assemblies of varying lengths shall be made to ensure that the PIM adds in-phase. Assemble 2 additional DUTs. The first one is to be  $\lambda/6$  longer and the second one is to be  $\lambda/3$  longer at the receive frequency of test. The PIM of the three assemblies is measured to determine which DUT exhibits maximum PIM. The impact test is to be performed on this DUT.

Multiple fixed frequency may be used in lieu of varying the cable length.

---



# British Standards Institution (BSI)

BSI is the national body responsible for preparing British Standards and other standards-related publications, information and services.

BSI is incorporated by Royal Charter. British Standards and other standardization products are published by BSI Standards Limited.

## About us

We bring together business, industry, government, consumers, innovators and others to shape their combined experience and expertise into standards-based solutions.

The knowledge embodied in our standards has been carefully assembled in a dependable format and refined through our open consultation process. Organizations of all sizes and across all sectors choose standards to help them achieve their goals.

## Information on standards

We can provide you with the knowledge that your organization needs to succeed. Find out more about British Standards by visiting our website at [bsigroup.com/standards](http://bsigroup.com/standards) or contacting our Customer Services team or Knowledge Centre.

## Buying standards

You can buy and download PDF versions of BSI publications, including British and adopted European and international standards, through our website at [bsigroup.com/shop](http://bsigroup.com/shop), where hard copies can also be purchased.

If you need international and foreign standards from other Standards Development Organizations, hard copies can be ordered from our Customer Services team.

## Subscriptions

Our range of subscription services are designed to make using standards easier for you. For further information on our subscription products go to [bsigroup.com/subscriptions](http://bsigroup.com/subscriptions).

With **British Standards Online (BSOL)** you'll have instant access to over 55,000 British and adopted European and international standards from your desktop. It's available 24/7 and is refreshed daily so you'll always be up to date.

You can keep in touch with standards developments and receive substantial discounts on the purchase price of standards, both in single copy and subscription format, by becoming a **BSI Subscribing Member**.

**PLUS** is an updating service exclusive to BSI Subscribing Members. You will automatically receive the latest hard copy of your standards when they're revised or replaced.

To find out more about becoming a BSI Subscribing Member and the benefits of membership, please visit [bsigroup.com/shop](http://bsigroup.com/shop).

With a **Multi-User Network Licence (MUNL)** you are able to host standards publications on your intranet. Licences can cover as few or as many users as you wish. With updates supplied as soon as they're available, you can be sure your documentation is current. For further information, email [bsmusales@bsigroup.com](mailto:bsmusales@bsigroup.com).

## BSI Group Headquarters

389 Chiswick High Road London W4 4AL UK

## Revisions

Our British Standards and other publications are updated by amendment or revision.

We continually improve the quality of our products and services to benefit your business. If you find an inaccuracy or ambiguity within a British Standard or other BSI publication please inform the Knowledge Centre.

## Copyright

All the data, software and documentation set out in all British Standards and other BSI publications are the property of and copyrighted by BSI, or some person or entity that owns copyright in the information used (such as the international standardization bodies) and has formally licensed such information to BSI for commercial publication and use. Except as permitted under the Copyright, Designs and Patents Act 1988 no extract may be reproduced, stored in a retrieval system or transmitted in any form or by any means – electronic, photocopying, recording or otherwise – without prior written permission from BSI. Details and advice can be obtained from the Copyright & Licensing Department.

## Useful Contacts:

### Customer Services

**Tel:** +44 845 086 9001

**Email (orders):** [orders@bsigroup.com](mailto:orders@bsigroup.com)

**Email (enquiries):** [cservices@bsigroup.com](mailto:cservices@bsigroup.com)

### Subscriptions

**Tel:** +44 845 086 9001

**Email:** [subscriptions@bsigroup.com](mailto:subscriptions@bsigroup.com)

### Knowledge Centre

**Tel:** +44 20 8996 7004

**Email:** [knowledgecentre@bsigroup.com](mailto:knowledgecentre@bsigroup.com)

### Copyright & Licensing

**Tel:** +44 20 8996 7070

**Email:** [copyright@bsigroup.com](mailto:copyright@bsigroup.com)



...making excellence a habit.™