

BS EN 62026-7:2013



BSI Standards Publication

Low-voltage switchgear and controlgear — Controller-device interfaces (CDIs)

Part 7: CompoNet

bsi.

...making excellence a habit.™

National foreword

This British Standard is the UK implementation of EN 62026-7:2013. It is derived from IEC 62026-7:2010. It supersedes DD IEC/PAS 62026-7:2009, which is withdrawn.

A CENELEC common modification has been implemented in the text: a NOTE has been inserted in subclause 9.2.8.1.

The UK participation in its preparation was entrusted by Technical Committee PEL/17, Switchgear, controlgear, and HV-LV co-ordination, to Subcommittee PEL/17/2, Low voltage switchgear and controlgear.

A list of organizations represented on this subcommittee can be obtained on request to its secretary.

This publication does not purport to include all the necessary provisions of a contract. Users are responsible for its correct application.

© The British Standards Institution 2013.

Published by BSI Standards Limited 2013

ISBN 978 0 580 65520 3

ICS 29.130.20; 33.200

Compliance with a British Standard cannot confer immunity from legal obligations.

This British Standard was published under the authority of the Standards Policy and Strategy Committee on 31 July 2013.

Amendments/corrigenda issued since publication

Date	Text affected
------	---------------

**Low-voltage switchgear and controlgear -
Controller-device interfaces (CDIs) -
Part 7: CompoNet
(IEC 62026-7:2010, modified)**

Appareillage à basse tension -
Interfaces appareil de commande-appareil
(CDI) -
Partie 7: CompoNet
(CEI 62026-7:2010, modifiée)

Niederspannungsschaltgeräte -
Steuerung-Geräte-Netzwerke (CDIs) -
Teil 7: CompoNet
(IEC 62026-7:2010, modifiziert)

This European Standard was approved by CENELEC on 2012-12-03. CENELEC members are bound to comply with the CEN/CENELEC Internal Regulations which stipulate the conditions for giving this European Standard the status of a national standard without any alteration.

Up-to-date lists and bibliographical references concerning such national standards may be obtained on application to the CEN-CENELEC Management Centre or to any CENELEC member.

This European Standard exists in three official versions (English, French, German). A version in any other language made by translation under the responsibility of a CENELEC member into its own language and notified to the CEN-CENELEC Management Centre has the same status as the official versions.

CENELEC members are the national electrotechnical committees of Austria, Belgium, Bulgaria, Croatia, Cyprus, the Czech Republic, Denmark, Estonia, Finland, Former Yugoslav Republic of Macedonia, France, Germany, Greece, Hungary, Iceland, Ireland, Italy, Latvia, Lithuania, Luxembourg, Malta, the Netherlands, Norway, Poland, Portugal, Romania, Slovakia, Slovenia, Spain, Sweden, Switzerland, Turkey and the United Kingdom.

CENELEC

European Committee for Electrotechnical Standardization
Comité Européen de Normalisation Electrotechnique
Europäisches Komitee für Elektrotechnische Normung

Management Centre: Avenue Marnix 17, B - 1000 Brussels

Foreword

This document (EN 62026-7:2013) consists of the text of IEC 62026-7:2010 prepared by IEC/SC 17B "Low-voltage switchgear and controlgear" of IEC/TC 17 "Switchgear and controlgear", together with the common modifications prepared by CLC/TC 17B "Low-voltage switchgear and controlgear".

The following dates are fixed:

- latest date by which this document has to be implemented (dop) 2013-12-03
at national level by publication of an identical national standard or by endorsement
- latest date by which the national standards conflicting (dow) 2015-12-03
with this document have to be withdrawn

Clauses, subclauses, notes, tables, figures and annexes which are additional to those in IEC 62026-7:2010 are prefixed "Z".

Attention is drawn to the possibility that some of the elements of this document may be the subject of patent rights. CENELEC [and/or CEN] shall not be held responsible for identifying any or all such patent rights.

This document has been prepared under a mandate given to CENELEC by the European Commission and the European Free Trade Association, and supports essential requirements of EU Directive(s).

For the relationship with EU Directive 2004/108/EC, see informative Annex ZZ, which is an integral part of this document.

This standard covers the Principle Elements of the Safety Objectives for Electrical Equipment Designed for Use within Certain Voltage Limits (LVD - 2006/95/EC).

Endorsement notice

The text of the International Standard IEC 62026-7:2010 was approved by CENELEC as a European Standard with agreed common modifications.

Annex ZA (normative)

Normative references to international publications with their corresponding European publications

The following documents, in whole or in part, are normatively referenced in this document and are indispensable for its application. For dated references, only the edition cited applies. For undated references, the latest edition of the referenced document (including any amendments) applies.

NOTE Where an International Publication has been modified by common modifications, indicated by (mod), the relevant EN/HD applies.

<u>Publication</u>	<u>Year</u>	<u>Title</u>	<u>EN/HD</u>	<u>Year</u>
CISPR 11 (mod)	2009	Industrial, scientific and medical equipment - Radio-frequency disturbance characteristics - Limits and methods of measurement	EN 55011	2009
IEC 60512-1	-	Connectors for electronic equipment - Tests and measurements - Part 1: General	EN 60512-1	2001
IEC 60529	-	Degrees of protection provided by enclosures (IP Code)	EN 60529 + corr. May + A1	1991 1993 2000
IEC 61000-4-2	-	Electromagnetic compatibility (EMC) - Part 4-2: Testing and measurement techniques - Electrostatic discharge immunity test	EN 61000-4-2	2009
IEC 61000-4-3	-	Electromagnetic compatibility (EMC) - Part 4-3: Testing and measurement techniques - Radiated, radio-frequency, electromagnetic field immunity test	EN 61000-4-3 + A1 + A2	2006 2008 2010
IEC 61000-4-4	-	Electromagnetic compatibility (EMC) - Part 4-4: Testing and measurement techniques - Electrical fast transient/burst immunity test	EN 61000-4-4 + A1	2004 2010
IEC 61000-4-5	-	Electromagnetic compatibility (EMC) - Part 4-5: Testing and measurement techniques - Surge immunity test	EN 61000-4-5	2006
IEC 61000-4-6	-	Electromagnetic compatibility (EMC) - Part 4-6: Testing and measurement techniques - Immunity to conducted disturbances, induced by radio-frequency fields	EN 61000-4-6	2009
IEC 61076-2-101	-	Connectors for electronic equipment - Product requirements - Part 2-101: Circular connectors - Detail specification for M12 connectors with screw-locking	EN 61076-2-101	2008
IEC 61131-2	-	Programmable controllers - Part 2: Equipment requirements and tests	EN 61131-2	2007

<u>Publication</u>	<u>Year</u>	<u>Title</u>	<u>EN/HD</u>	<u>Year</u>
IEC 61158-5-2	2007	Industrial communication networks - Fieldbus specifications - Part 5-2: Application layer service definition - Type 2 elements	EN 61158-5-2 ¹⁾	2008
IEC 61158-6-2	2007	Industrial communication networks - Fieldbus specifications - Part 6-2: Application layer protocol specification - Type 2 elements	EN 61158-6-2 ²⁾	2008
IEC 61918	2010	Industrial communication networks - Installation of communication networks in industrial premises	-	-
IEC 62026-1	-	Low-voltage switchgear and controlgear - Controller-device interfaces (CDIs) - Part 1: General rules	EN 62026-1	2007
ISO/IEC 7498-1	-	Information technology - Open Systems Interconnection - Basic Reference Model: The Basic Model	EN ISO/IEC 7498-1	-

1) EN 61158-5-2 is superseded by EN 61158-5-2:2012, which is based on IEC 61158-5-2:2010.

2) EN 61158-6-2 is superseded by EN 61158-6-2:2012, which is based on IEC 61158-6-2:2010.

Annex ZZ
(informative)

Coverage of Essential Requirements of EU Directives

This European Standard has been prepared under a mandate given to CENELEC by the European Commission and the European Free Trade Association and within its scope the standard covers all relevant essential requirements as given in Article 1 of Annex I of Directive 2004/108/EC.

Compliance with this standard provides one means of conformity with the specified essential requirements of the Directive concerned.

WARNING: Other requirements and other EU Directives may be applicable to the products falling within the scope of this standard.

CONTENTS

INTRODUCTION	15
1 Scope	17
2 Normative references	17
3 Terms, definitions, symbols, abbreviated terms and conventions	18
3.1 Terms and definitions	18
3.2 Symbols and abbreviated terms	21
4 Classification	22
4.1 General	22
4.2 Network specifications	24
4.3 Components	24
4.4 CompoNet communication model	25
4.5 CompoNet and CIP	25
5 Characteristics	26
5.1 Communication cycle	26
5.1.1 General	26
5.1.2 Time domains	26
5.1.3 A typical communication cycle	27
5.2 Messaging protocol	27
5.2.1 Message frame format	27
5.2.2 Message frame types	29
5.2.3 Explicit messaging	52
5.2.4 Explicit messaging client/server timing requirement	62
5.3 CompoNet communication object classes	64
5.3.1 General	64
5.3.2 Identity object class definition (class ID code: 01 _{Hex})	64
5.3.3 Message router object class definition (class ID code: 02 _{Hex})	64
5.3.4 Connection object class definition (class ID code: 05 _{Hex})	64
5.3.5 CompoNet Link object class definition (class ID code: F7 _{Hex})	74
5.3.6 CompoNet Repeater object (class ID code: F8 _{Hex})	80
5.4 Network access state machine	82
5.4.1 General	82
5.4.2 Network access events	82
5.4.3 State transition diagram	84
5.4.4 Data rate auto-detection	85
5.4.5 Duplicate MAC ID detection	86
5.4.6 Repeater behaviour	87
5.5 I/O connection	88
5.6 TDMA	88
5.6.1 General	88
5.6.2 Data link timing features	89
5.6.3 Calculation of Time Domain	92
5.7 Physical layer	98
5.7.1 General	98
5.7.2 Physical signalling	98
5.7.3 Master port requirements	98

5.7.4	Slave port requirements	101
5.7.5	Receiving signal requirements for master and slave ports	104
5.7.6	Requirements for digital processing	105
5.7.7	Recommended circuits and component parameters	108
5.7.8	Isolation	113
5.7.9	Transmission medium	114
5.7.10	Topology	115
5.7.11	Link power	121
5.7.12	Repeater implementation	124
6	Product information	125
7	Normal service, mounting and transport conditions	125
7.1	Normal service conditions	125
7.1.1	General	125
7.1.2	Ambient air temperature	126
7.1.3	Altitude	126
7.1.4	Climatic conditions	126
7.2	Conditions during transport and storage	126
7.3	Mounting	126
8	Constructional and performance requirements	126
8.1	Indicators and configuration switches	126
8.1.1	Status indicators	126
8.1.2	Switches	128
8.1.3	CompoNet marking	129
8.2	CompoNet cable	130
8.2.1	Overview	130
8.2.2	Cable profile template	131
8.2.3	Round cable I profile	132
8.2.4	Round cable II profile	134
8.2.5	Flat cable I profile	136
8.2.6	Flat cable II profile	139
8.3	Terminator	141
8.3.1	General	141
8.3.2	Terminating resistor	141
8.3.3	Terminating capacitor	141
8.4	Connectors	141
8.4.1	General	141
8.4.2	Template	141
8.4.3	Engaging specification for connector profiles: open, flat I, flat II	143
8.4.4	Specifications of hooks for connector profiles: open, flat I, flat II	145
8.4.5	Open connector profile	146
8.4.6	Profile of flat connector I	150
8.4.7	Profile of flat connector II	155
8.4.8	Profile of sealed M12 connector	158
8.5	Node power supply implementation	159
8.5.1	General	159
8.5.2	Requirement for node power supply connection	159
8.5.3	The requirements for nodes powered by network power supplies:	160
8.6	Miswiring protection	161
8.7	Electromagnetic compatibility (EMC)	161

8.7.1	General	161
8.7.2	Immunity	161
8.7.3	Emissions	162
9	Tests	162
9.1	General	162
9.2	Electrical testing	163
9.2.1	Slave port operation voltage test	163
9.2.2	Reverse connected power supply line	163
9.2.3	Momentary power interruption	164
9.2.4	Isolation	164
9.2.5	Input impedance	165
9.2.6	Output waveform	166
9.2.7	Minimum input waveform	166
9.2.8	Electromagnetic compatibility testing	167
9.3	Mechanical test	168
9.4	Logical test	168
9.4.1	General	168
9.4.2	Test of slaves and repeaters	168
9.4.3	Test of master	171
Annex A (normative)	CompoNet common services	174
Annex B (normative)	CompoNet error codes	175
Annex C (normative)	Connection path attribute definition	176
Annex D (normative)	Data type specification and encoding	177
Annex E (normative)	Communication objects library	181
Annex F (normative)	Value ranges	182
Annex G (normative)	CN default time domain	183
	Bibliography	187
	Figure 1 – Segment layer	23
	Figure 2 – CompoNet components	25
	Figure 3 – Time domains	26
	Figure 4 – A typical communication cycle	27
	Figure 5 – A general frame	27
	Figure 6 – Preamble of frames	28
	Figure 7 – Transmission direction	28
	Figure 8 – Transmission direction	29
	Figure 9 – OUT frame format	30
	Figure 10 – OUT command code	30
	Figure 11 – TRG frame format	32
	Figure 12 – TRG command code	32
	Figure 13 – CN frame format	32
	Figure 14 – CN command code	33
	Figure 15 – IN frame format	34
	Figure 16 – IN command code	35
	Figure 17 – A_EVENT frame format	35

Figure 18 – A_EVENT command code	36
Figure 19 – B_EVENT frame format	37
Figure 20 – B_EVENT command code meanings	38
Figure 21 – B_EVENT message format	39
Figure 22 – E_CMD block	39
Figure 23 – Group block.....	40
Figure 24 – Item block	40
Figure 25 – Status Read (STR Response) event data	43
Figure 26 – Configuration event data (STW Request)	45
Figure 27 – Poll data.....	46
Figure 28 – B_EVENT general decoding phase	47
Figure 29 – Flow chart for processing a matched STW request	49
Figure 30 – BEACON frame format.....	50
Figure 31 – BEACON command code	50
Figure 32 – Object diagram of A_Event message flow	52
Figure 33 – A_EVENT message format	52
Figure 34 – Compact message type request format (non-fragmented frame/first fragment frame)	53
Figure 35 – Expanded message type request format (non-fragmented frame/first fragment frame)	54
Figure 36 – Compact/Expanded message successful response format (unfragmented frame/ first fragment frame)	54
Figure 37 – Compact/Expanded message unsuccessful response format (unfragmented frame/first fragment frame).....	55
Figure 38 – Compact/Expanded message request format for fragments	55
Figure 39 – Compact/Expanded message response format for fragments	55
Figure 40 – Service data format	56
Figure 41 – Predefined master/slave I/O connection state transition diagram	70
Figure 42 – Predefined master/slave I/O connection state transition diagram	72
Figure 43 – Connection flow	73
Figure 44 – Allocate request service data	78
Figure 45 – Allocate response service data	79
Figure 46 – Release request service data	79
Figure 47 – Reset service parameter	82
Figure 48 – State transition diagram	84
Figure 49 – Sub-state of non-participated state	85
Figure 50 – Sub-state of participated state	85
Figure 51 – Data rate detection diagram	86
Figure 52 – BEACON changed by repeaters	88
Figure 53 – Multicast I/O connections	88
Figure 54 – Master MAC and Phy. circuit diagram	89
Figure 55 – Slave MAC and Phy. circuit diagram	90
Figure 56 – Repeater MAC and Phy. circuit diagram	91
Figure 57 – Transmission process	92

Figure 58 – Transmission cycle model	93
Figure 59 – CnDefaultTimeDomain cycle model	95
Figure 60 – Master event communication model	96
Figure 61 – Slave event communication model	97
Figure 62 – Manchester encoding (inverted)	98
Figure 63 – Master port transmit mask	100
Figure 64 – Output waveform test circuit for master or slave port	101
Figure 65 – Slave port transmit mask	103
Figure 66 – Receive mask 1	104
Figure 67 – Receive mask 2	105
Figure 68 – Receive mask 3	105
Figure 69 – PHY/MAC interface diagram	106
Figure 70 – Digital receive mask 1	106
Figure 71 – Digital receive mask 2	107
Figure 72 – Digital receive mask 3	107
Figure 73 – Logical transmit mask	108
Figure 74 – Recommended circuit for a master port	109
Figure 75 – Recommended circuit for a slave port	110
Figure 76 – Transformer symbol	110
Figure 77 – Driver voltage measurement circuit	112
Figure 78 – Propagation delay test circuit	112
Figure 79 – An isolation example of a master port	113
Figure 80 – An isolation example of an I/O module with connectivity to other power sources	114
Figure 81 – An isolation example of a simple slave that requires connection to devices with ungrounded signal wiring	114
Figure 82 – An isolation example of a non-network powered slave	114
Figure 83 – Media topology	116
Figure 84 – Position of a terminator	117
Figure 85 – Number of devices per segment	117
Figure 86 – Cable length limitation Illustration	118
Figure 87 – Branch restriction	118
Figure 88 – Wiring selection	119
Figure 89 – General wiring method	120
Figure 90 – Flexible wiring method	121
Figure 91 – Power dispatching method	123
Figure 92 – Network segment powered by the master	123
Figure 93 – Connection with power supply	123
Figure 94 – Network segments powered by repeaters	124
Figure 95 – A simplified diagram for a repeater	125
Figure 96 – Outline of round cable II	136
Figure 97 – Outline of flat cable I	138
Figure 98 – Dimension of flat cable I	139
Figure 99 – Outline of flat cable II	140

Figure 100 – Dimension of flat cable II	141
Figure 101 – Engaging dimensions of plug connector	143
Figure 102 – Contact space for plug connector.	144
Figure 103 – Engaging dimensions of jack connector.....	145
Figure 104 – Connector hook	146
Figure 105 – Open connector plug (informative)	148
Figure 106 – Open connector jack (informative).....	149
Figure 107 – Method to measure contact resistance (open connectors).....	150
Figure 108 – De-rating current for connectors.	150
Figure 109 – Flat connector I plug.....	153
Figure 110 – Flat connector I jack (informative)	154
Figure 111 – Method to measure contact resistance (flat I, II connectors).	155
Figure 112 – Flat connector II plug (informative).....	157
Figure 113 – Flat connector II jack (informative)	157
Figure 114 – Marking connector for trunk lines	158
Figure 115 – M12 connector pinout	159
Figure 116 – Link power circuits.	160
Figure 117 – Power-drop along a cable	160
Figure 118 – Power design for a node (informative).....	161
Figure 119 – Operating voltage test circuit	163
Figure 120 – Reverse connected power supply line	164
Figure 121 – Isolation	165
Figure 122 – Input impedance	165
Figure 123 – Output slave test circuit for slave port	166
Figure 124 – Minimum input waveform test circuit.	167
Figure 125 – Minimum input waveform test system	167
Figure 126 – Data link test for slave and repeater DUT.	169
Figure 127 – Test configuration for minimum traffic of master DUT	172
Figure 128 – Test configuration for proxy of master DUT	173
Figure D.1 – An example to generate CRC	180
Table 1 – Network specifications	24
Table 2 – OSI reference model and CompoNet	26
Table 3 – Command codes.	28
Table 4 – Command restrictions for slave MAC	29
Table 5 – Block name description.....	30
Table 6 – CN target	30
Table 7 – I/O refresh.....	31
Table 8 – Block name description.....	32
Table 9 – Block name description.....	33
Table 10 – Duplication checking function status.....	33
Table 11 – A_EVENT sending request.....	33
Table 12 – Status of CN frames	34

Table 13 – Warning bit of CN frames	34
Table 14 – Alarm bit of CN frames.	34
Table 15 – Block name description	34
Table 16 – Encoded length	35
Table 17 – Block name description	36
Table 18 – Acknowledgement bit of A_EVENT	36
Table 19 – Command type of A_EVENT	36
Table 20 – Block name description	37
Table 21 – Acknowledgement bit of B_EVENT	38
Table 22 – Command type of B_EVENT	38
Table 23 – E_CMD block meanings	39
Table 24 – Group block meanings	40
Table 25 – Item block meanings	40
Table 26 – Processing rules for a STR request	48
Table 27 – Processing rules for an A_EVENT poll request	48
Table 28 – Processing rules for a STW request	48
Table 29 – STW request commands	50
Table 30 – Block name description	50
Table 31 – Control code of BEACON frames	51
Table 32 – Speed Code of BEACON frames	51
Table 33 – Control code format	56
Table 34 – A Data encoding example	58
Table 35 – Fragment type values	59
Table 36 – Fragmented transmission	60
Table 37 – Fragmented reception	61
Table 38 – Explicit message timeout values	63
Table 39 – Maximum value of expected packet rate	65
Table 40 – CompoNet connection object attribute access rules	65
Table 41 – CompoNet Link object specific additional error codes	68
Table 42 – Connection instance ID for predefined master/slave connections	69
Table 43 – Default multicast poll connection object attribute values	69
Table 44 – Predefined master/slave I/O connection state event matrix	70
Table 45 – CompoNet Link class attributes	74
Table 46 – CompoNet Link class services	74
Table 47 – CompoNet Link instance attributes	74
Table 48 – MAC ID range	75
Table 49 – Data rate	76
Table 50 – Allocation choice	76
Table 51 – Data rate switch value	76
Table 52 – Bit definitions for node state octet	77
Table 53 – Bit definitions for node network state	77
Table 54 – CompoNet Link object common services	77
Table 55 – CompoNet Link Object class specific services	78

Table 56 – Allocation choice octet contents	78
Table 57 – EPR value	79
Table 58 – Explicit message timer	79
Table 59 – Release master/slave connection set request parameters	79
Table 60 – Release choice octet contents	80
Table 61 – Repeater class attribute	80
Table 62 – Repeater class services	80
Table 63 – Instance attributes of repeater class	81
Table 64 – Repeater common service	82
Table 65 – Reset attributes	82
Table 66 – Data rate and network watchdog time periods	83
Table 67 – Description of the state machine	84
Table 68 – Duplicate MAC ID detection mechanism	87
Table 69 – Repeating directions of frames	87
Table 70 – Master timing features	89
Table 71 – Slave timing features	90
Table 72 – Repeater timing features	91
Table 73 – Cable propagation delay	91
Table 74 – Maximum cable length	92
Table 75 – Parameters in TimeDomain calculation	92
Table 76 – Frame marks	93
Table 77 – TimeDomain settings for nodes at first segment layer	94
Table 78 – TimeDomain settings for nodes at 2 nd and 3 rd segment layers	94
Table 79 – Repeater delay for CnDefaultTimeDomain calculation	95
Table 80 – Parameters for CnDefaultTimeDomain calculation	95
Table 81 – First segment layer settings	96
Table 82 – Settings for 2 nd and 3 rd segment layers	96
Table 83 – Parameters for Event Time Domain calculations	97
Table 84 – CompoNet Manchester encoding	98
Table 85 – Allowable connectors for the master port	98
Table 86 – Master port impedance during receive	99
Table 87 – Master port impedance during transmit	99
Table 88 – Master port transmit specifications for data rate of 4 Mbit/s; 3 Mbit/s and 1,5 Mbit/s	100
Table 89 – Master port transmit specifications for data rate of 93,75 kbit/s	100
Table 90 – Allowable connectors for permanently attached cables	101
Table 91 – Allowable connectors for the slave port	101
Table 92 – Slave port impedance during receive	102
Table 93 – Slave port impedance during transmit	102
Table 94 – Slave port transmit specifications for data rate of 4 Mbit/s; 3 Mbit/s and 1,5 Mbit/s	103
Table 95 – Slave port transmit specifications for data rate of 93,75 kbit/s	103
Table 96 – Specifications for digital receive mask 1	106
Table 97 – Specifications for digital receive mask 2	107

Table 98 – Specifications for digital receive mask 3	107
Table 99 – Specifications for logical transmit.	108
Table 100 – Specification for pulse transformer	111
Table 101 – Specifications for transformer core	111
Table 102 – Specifications for transceiver	112
Table 103 – Sending.	113
Table 104 – Receiving	113
Table 105 – Cable types	115
Table 106 – Cable conductor colours	115
Table 107 – CompoNet round cable I: network limitations	117
Table 108 – CompoNet 4-conductor cables: network limitations	118
Table 109 – Resistance characteristics	121
Table 110 – Network power supply specifications	121
Table 111 – Local power supply specifications	122
Table 112 – Node external power supply specifications	122
Table 113 – Module status indicator.	127
Table 114 – CDI status indicator	127
Table 115 – Data rate switch encoding	128
Table 116 – Addresses switches	128
Table 117 – Indicator marking	129
Table 118 – Node address switch and device type marking.	129
Table 119 – Connector marking.	130
Table 120 – Cable profile: data pair specification.	131
Table 121 – Cable profile: d.c. power pair specification	131
Table 122 – Cable profile: general specification	132
Table 123 – Round cable I: data pair specification	133
Table 124 – Round cable I: d.c. power pair specification	133
Table 125 – Round cable I: general specification	134
Table 126 – Round cable II: data pair specification	135
Table 127 – Round cable II: d.c. power pair specification	135
Table 128 – Round cable II: general specification	136
Table 129 – Flat cable I: data pair specification	137
Table 130 – Flat cable I: d.c. power pair specification	137
Table 131 – Flat cable I: general specification	138
Table 132 – Flat cable II: data pair specification	139
Table 133 – Flat cable II: d.c. power pair specification	140
Table 134 – Flat cable II: general specification	140
Table 135 – Connector profile template	142
Table 136 – Specification of open connector	147
Table 137 – Specification of flat connector I	151
Table 138 – Specification of flat connector II	155
Table 139 – Specification of sealed M12 connector	158
Table 140 – Input impedance for master.	166

Table 141 – Input impedance for slave166
Table B.1 – Newly defined CompoNet error codes175
Table F.1 – MAC ID and node address ranges.182
Table G.1 – CN default time domain table for 4 Mbit/s data rate.183
Table G.2 – CN default time domain table for 3 Mbit/s data rate.184
Table G.3 – CN default time domain table for 1,5 Mbit/s data rate.185
Table G.4 – CN default time domain table for 93,75 kbit/s data rate186

INTRODUCTION

CompoNet™ is intended for use in, but is not limited to, industrial automation applications. These applications may include devices such as limit switches, proximity sensors, electro-pneumatic valves, relays, motor starters, operator interface panels, analogue inputs, analogue outputs and controllers.

Patent declaration

The International Electrotechnical Commission (IEC) draws attention to the fact that it is claimed that compliance with this document may involve the use of the following patents owned by OMRON Corporation:

JP Patent Number 4023342	DUPLICATE MAC. ADDRESS DETECTING METHOD, SLAVE AND MASTER IN FIELD BUS SYSTEM, AND FIELD BUS
JP Patent Number 4107110	FIELD BUS SYSTEM, CONNECTION CONFIRMING METHOD AND MASTER
JP Patent Number 3293089	REMOTE I/O SYSTEM FOR PLC AND EXECUTION METHOD THEREOF
JP Patent Number 3925660 and its counterpart patents in other countries	STARTING CONTROL METHOD OF COMMUNICATION MASTER
JP Patent Number 4006605 and its counterpart patents in other countries	COMMUNICATION SYSTEM REDUCED IN INFLUENCE OF REPEATER DELAY
JP Application Number 2004-059864	COMMUNICATION DEVICE AND NETWORK SYSTEM
JP Application Number 2004-022243	CONNECTOR FOR CONNECTION CABLE
JP Application Number 2007-167281	COMMUNICATION SYSTEM REDUCED IN INFLUENCE OF REPEATER DELAY
JP Application Number 2005-252414	NETWORK REPEATING WITH FILTERING FUNCTION
JP Application Number 2005-252758	A EVENT COMMUNICATION METHOD FOR PROGRAMABLE CONTROLLER SYSTEMS
JP Application Number 2005-203496	GETTING NETWORK CONFIGURATION INFORMATION IN PLC SYSTEMS
JP Application Number 2002-334265	A I/O MAPPING METHOD FOR NETWORK SYSTEMS AND CONTROLLERS
JP Application Number 2005-252682	A SCHEDULING METHOD FOR EVENT COMMUNICATIONS
JP Application Number 2005-105543 and its counterpart patents in other countries	RECEIVED DATA COMPENSATION DEVICE

IEC takes no position concerning the evidence, validity and scope of these patent rights.

The holder of this patent right has assured the IEC that he/she is willing to negotiate licences under reasonable and non-discriminatory terms and conditions with applicants throughout the

world. In this respect, the statement of the holder of this patent right is registered with IEC. Information may be obtained from:

ODVA, Inc.
2370 E. Stadium Boulevard #1000
Ann Arbor, Michigan U.S.A. 48104

Attention is drawn to the possibility that some of the elements of this document may be the subject of patent rights other than those identified above. IEC shall not be held responsible for identifying any or all such patent rights.

ISO (www.iso.org/patents) and IEC (http://www.iec.ch/tctools/patent_decl.htm) maintain on-line data bases of patents relevant to their standards. Users are encouraged to consult the data bases for the most up to date information concerning patents.

LOW-VOLTAGE SWITCHGEAR AND CONTROLGEAR – CONTROLLER-DEVICE INTERFACES (CDIs) –

Part 7: CompoNet

1 Scope

This part of IEC 62026 specifies an interface system providing bit-level and word-level communication between a controller and control circuit devices such as sensors, actuators, and switching elements. The interface system uses cabling with round or flat profiles containing a two conductor signalling pair and optionally a two conductor power supply pair. This part establishes requirements for the interchangeability of components with such interfaces.

This part of IEC 62026 specifies the following particular requirements for CompoNet™ 1):

- requirements for interfaces between a controller and control circuit devices;
- normal service conditions for devices;
- constructional and performance requirements;
- tests to verify conformance to requirements.

These particular requirements apply in addition to the general requirements of IEC 62026-1.

2 Normative references

The following referenced documents are indispensable for the application of this document. For dated references, only the edition cited applies. For undated references, the latest edition of the referenced document (including any amendments) applies.

IEC 60512-1, *Connectors for electronic equipment – Tests and measurements – Part 1: General*

IEC 60529, *Degrees of protection provided by enclosures (IP Code)*

IEC 61000-4-2, *Electromagnetic compatibility (EMC) – Part 4-2: Testing and measurement techniques – Electrostatic discharge immunity test*

IEC 61000-4-3, *Electromagnetic compatibility (EMC) – Part 4-3: Testing and measurement techniques – Radiated, radio-frequency, electromagnetic field immunity test*

IEC 61000-4-4, *Electromagnetic compatibility (EMC) – Part 4-4: Testing and measurement techniques – Electrical fast transient/burst immunity test*

IEC 61000-4-5, *Electromagnetic compatibility (EMC) – Part 4-5: Testing and measurement techniques – Surge immunity test*

1) CompoNet™ is a trade name of Open DeviceNet Vendor Association, Inc. This information is given for the convenience of users of this International Standard and does not constitute an endorsement by IEC of the trademark holder or any of its products. Compliance to this standard does not require use of the trade name CompoNet™. Use of the trade name CompoNet™ requires permission of Open DeviceNet Vendor Association, Inc.

IEC 61000-4-6, *Electromagnetic compatibility (EMC) – Part 4-6: Testing and measurement techniques – Immunity to conducted disturbances, induced by radio-frequency fields*

IEC 61076-2-101, *Connectors for electronic equipment – Product requirements – Part 2-101: Circular connectors – Detail specification for M12 connectors with screw-locking*

IEC 61131-2, *Programmable controllers – Part 2: Equipment requirements and tests*

IEC 61158-5-2:2007, *Industrial communication networks – Fieldbus specifications – Part 5-2: Application layer service definition – Type 2 elements*

IEC 61158-6-2:2007, *Industrial communication networks – Fieldbus specifications – Part 6-2: Application layer protocol specification – Type 2 elements*

IEC 61918:2010, *Industrial communication networks – Installation of communication networks in industrial premises*

IEC 62026-1, *Low-voltage switchgear and controlgear – Controller-device interfaces (CDIs) – Part 1: General rules*

CISPR 11:2009, *Industrial, scientific and medical equipment – Radio-frequency disturbance characteristics – Limits and methods of measurement*

ISO/IEC 7498-1, *Information technology – Open Systems Interconnection – Basic Reference Model: The Basic Model*

3 Terms, definitions, symbols and abbreviated terms

3.1 Terms and definitions

For the purposes of this document, the following terms and definitions apply.

3.1.1

BEACON

frame generated by the master to notify slaves and repeaters of the present transmission speed and network connection information

3.1.2

bit slave

I/O device working with data lengths not more than 4 bits

3.1.3

branch

a piece of cable making a T connection to a trunk or sub-trunk

3.1.4

CDI status indicator

visual indication reporting the status of the communication link at a CompoNet device

3.1.5

circuit speed

baud rate

communication rate in signalling symbols or marks/s on the transmission medium

NOTE Each CompoNet bit is Manchester encoded using two marks so a circuit speed of 6 Mmarks/s gives a transmission speed or data rate of 3 Mbits/s.

3.1.6

explicit message

command requesting the performance of a particular task and return of the results of the task performance to the requesting entity

[IEC 62026-3, 3.1.22, modified]

3.1.7

IN slave

addressable I/O device with only an input function, able to produce data for input to the master without consuming data

3.1.8

mark

signal symbol used in Manchester encoding technology and transmitted on the bus

NOTE Each data bit is encoded using 2 marks such that data 1 encodes to “01”, and data 0 encodes to “10”.

3.1.9

master

device that controls communication

NOTE There is only one master in a CompoNet network.

3.1.10

master port

port on a master or a repeater with built-in terminators

NOTE There is only one master port in a trunk or sub-trunk.

3.1.11

MIX slave

addressable I/O device with both an input and an output function, able to consume output data from the master and produce data for input to the master

NOTE The produced and consumed data sizes may be different.

3.1.12

MS LED indicator

module status indicator

visual indication reporting the power and operational state of a CompoNet device

3.1.13

node

device with a unique MAC ID

3.1.14

OUT slave

addressable I/O device with only an output function, able to consume output data from the master without producing data for input to the master

3.1.15

repeater

addressable device used for network expansion and communication signal modification

NOTE Repeaters can communicate with a master and execute functions such as message filtering to improve network communication efficiency, they are not passive devices.

3.1.16

segment

a collection of nodes and connecting physical media on a trunk or sub-trunk bounded by a master port and a terminator

3.1.17

slave

addressable device with actual I/O data

NOTE The maximum number of slaves in a CompoNet network is 384.

3.1.18

slave port

ports on a slave device or a repeater with no built-in terminators

3.1.19

STRNP

STR command targeted at a non-participated node

3.1.20

STRP

STR command targeted at a participated node

3.1.21

STWNP

STW command targeted at a non-participated node

3.1.22

STWNP_Reset

STWNP command with the parameter "ResetRequest = 1"

3.1.23

STWNP_Run

STWNP command with the parameter "Running=1"

3.1.24

STWP

STW command targeted at a participated node

3.1.25

STWP_Reset

STWP command with the parameter "ResetRequest = 1"

3.1.26

STWP_Standby_Lock

STWP command with the parameter "Running=0, UnRegistrant=1"

3.1.27

STWP_Standby_Offline

STWP command with the parameter "Running=0, UnRegistrant=0"

3.1.28

sub-branch

branch off another branch

3.1.29

sub-trunk

shortest communication line from the master port of a repeater to a terminator without going through another master port

NOTE 1 Sub-trunk refers to cabling connected to the master port of a repeater, it is a trunk line that is downstream of a repeater.

NOTE 2 A trunk or sub-trunk may be extended by daisy-chaining of connectors at a device

3.1.30

T-branch

a portion of cable connected to a trunk or sub-trunk by a T-connector

NOTE A T-branch may be extended by daisy-chaining of connectors at a device.

3.1.31

terminating capacitor

capacitor in a terminator

3.1.32

terminating resistor

resistor in a terminator

3.1.33

terminator

entity used to terminate a transmission line in its characteristic impedance to prevent reflections

NOTE 1 In some instances, the terminator may be embedded in an end device or in a connector.

[IEC 61918, 3.1.65]

NOTE 2 For the purpose of this standard, a terminator consists of a terminating resistor and a terminating capacitor.

3.1.34

transmission speed

data rate

communication rate in data bits/s on the transmission medium

NOTE Each CompoNet data bit is Manchester encoded using two marks, so the transmission speed in bits/s is half the circuit speed in marks/s.

3.1.35

trunk

shortest communication line from a master to a terminator on the same segment

NOTE A trunk or sub-trunk may be extended by daisy-chaining of connectors at a device.

3.1.36

word slave

I/O device working with data in 16 bit word(s)

3.2 Symbols and abbreviated terms

A_EVENT	Application <u>EVENT</u> communication
B_EVENT	Base memory <u>EVENT</u> communication
BEACON	notification frame generated by the master
CDI	controller device interface
CRC	cyclic redundancy check

CN	<u>C</u> on <u>N</u> ection status
EPR	expected package rate
EUT	equipment under test
IN	input data
LED	light emitting diode
LSB	least significant bit
MAC	media access controller
OUT	<u>O</u> U <u>T</u> put data
PHY	physical layer
PWB	printed wiring board
RMS	root mean square
SID	security identifier
SEM	state event matrix
STR	status read of B_Event frame
STW	status write of B_Event frame
TRG	<u>T</u> R <u>I</u> g <u>g</u> er
UCMM	unconnected message manager

4 Classification

4.1 General

CompoNet is a low-level network that provides high-speed communication between higher-level devices such as controllers and simple industrial devices such as sensors and actuators.

CompoNet connects controllers with sensors and actuators. The controller acts as the master while the sensors and actuators act as the slaves. Two types of slaves are provided. One is a Bit slave with up to 4-point data, and the other is a Word slave with 16-point data. Repeaters extend the communication length.

CompoNet usually consists of several segments each separated by a repeater. Each segment is connected on the network, but is classified from the viewpoint of the physical layer. As shown in Figure 1, the segment that has the master is called the first segment layer. Second and third segment layers can be added using repeaters, but no more than 2 such extra segments can be added. Thus master to slave separation is never more than 2-repeaters or 3-segments. A total of 64 repeaters can be used in one network. All segments shall operate at the same transmission speed.

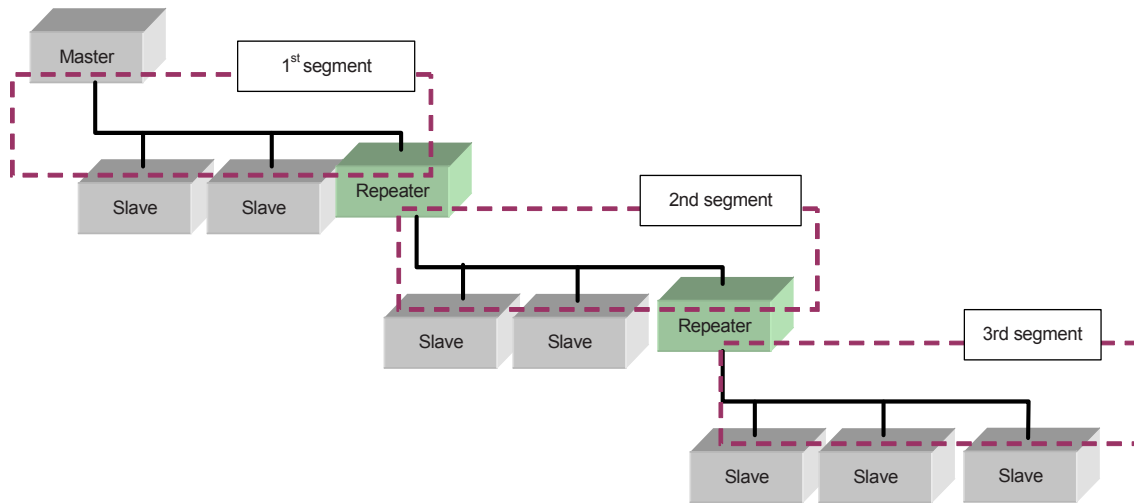

Figure 1 – Segment layer

The master or repeaters shall be connected at the end of segments.

A total of 384 slaves are connectable, i.e. 256 Bit slaves and 128 Word slaves. Within the restrictions set by the physical layer, however, a segment can have up to 32 slave or repeater nodes in total.

Four types of network cables are supported:

- round cable I, a 2-conductor unshielded round cable;
- round cable II, a 4-conductor unshielded round cable;
- flat cable I, a 4 conductor flat cable;
- flat cable II, a 4 conductor flat cable with additional covering.

While 2-conductor cables transmit only communication signals, 4-conductor cables transmit both communication signals and power.

Transmission speed is selectable among 4 Mbit/s; 3 Mbit/s; 1,5 Mbit/s and 93,75 kbit/s. The speed decides the maximum length of a trunk line. It is 30 m at 4 Mbit/s and 3 Mbit/s, 100 m at 1,5 Mbit/s, and 500 m at 93,75 kbit/s. Branching is supported in all speeds except for 4 Mbit/s.

CompoNet uses Manchester encoding technology to achieve higher reliability. For insulation, the physical layer circuits use pulse transformers and differential communication transceivers. The physical layer has master ports and slave ports. A master port has a built-in terminator, and is used by a master and a repeater. Slave ports have no terminators, and are used by slaves and repeaters.

CompoNet supports I/O data communication as well as explicit message communication. The master controls all communication in accordance with configuration settings. The master divides the communication cycle into multiple time domains, and allocates some to I/O communication and others to explicit message communication. Thus efficient communication is realized. For I/O communication, a time domain is allocated in every cycle interval, so that punctuality and time synchronisation is ensured. For explicit message communication, the time domain allocation varies with network load. Therefore, punctuality is not ensured.

4.2 Network specifications

Network specifications are shown in Table 1.

Table 1 – Network specifications

Item	Specification
Topology	Multi-drop and T-branch methods using passive cable components
Transmission speed	4 Mbit/s, 3 Mbit/s, 1,5 Mbit/s, 93,75 kbit/s
Transmission distance	Shall be described separately
Communication cycle	Shall be described separately
Communication media	CompoNet round cables CompoNet flat cables
Connectable master	CompoNet Master. Only one master is allowed in a CompoNet network
Connectable repeater	CompoNet Repeater
Connectable slave	CompoNet Word slaves CompoNet Bit slaves
Maximum number of repeaters in a network	64
Maximum number of nodes in a segment	A maximum of 32 nodes connected to the segment master port
Maximum number of I/O nodes in networks with repeaters	Maximum of 64 IN and 64 OUT word slaves, total 128 Maximum of 128 IN and 128 OUT bit slaves, total 256 Additional rules apply to networks using MIX slaves
Maximum number of I/O nodes in networks without repeaters	32
Available node address	
Word	IN 0 to 63
Word	OUT 0 to 63
Bit	IN 0 to 127
Bit	OUT 0 to 127
Repeater	0 to 63
Number of occupied points per I/O node address	16 points per word-slave address 2 points per bit-slave address
Repeater availability	Maximum 64 repeaters in a network
Maximum segment layers	3
Automatic data rate function	Supported by the MAC

4.3 Components

CompoNet network consists of the following components used to form a network as shown in Figure 2:

- **CompoNet master:** a device that controls communication. There is only one master in a CompoNet network;
- **CompoNet slave:** a device that produces and consumes actual I/O data. There are two types of slaves, Word slaves and Bit slaves. Word slaves deal with 8 bit data words. Bit slaves deal with 2 or 4 bit data units to improve communication efficiency of simple devices;

- **CompoNet repeater:** a device that provides network expansion and communication signal modification. Each repeater has a node address. It can communicate with a master and execute some intelligence functions to improve network communication efficiency. They are not passive devices;
- **CompoNet power supply:** a device providing 24 V d.c.. On 4-conductor segments, power shall be supplied at the master port. On 2-conductor segments, an individual power supply shall be used at each slave;
- **CompoNet terminator:** a passive device to improve communication performance. A terminator shall be mounted on the farthest end of the trunk line from the master port of a master or a repeater. All terminators include a resistance connected between the signal lines and a 4 cable terminator also includes a capacitor connected between the power lines.

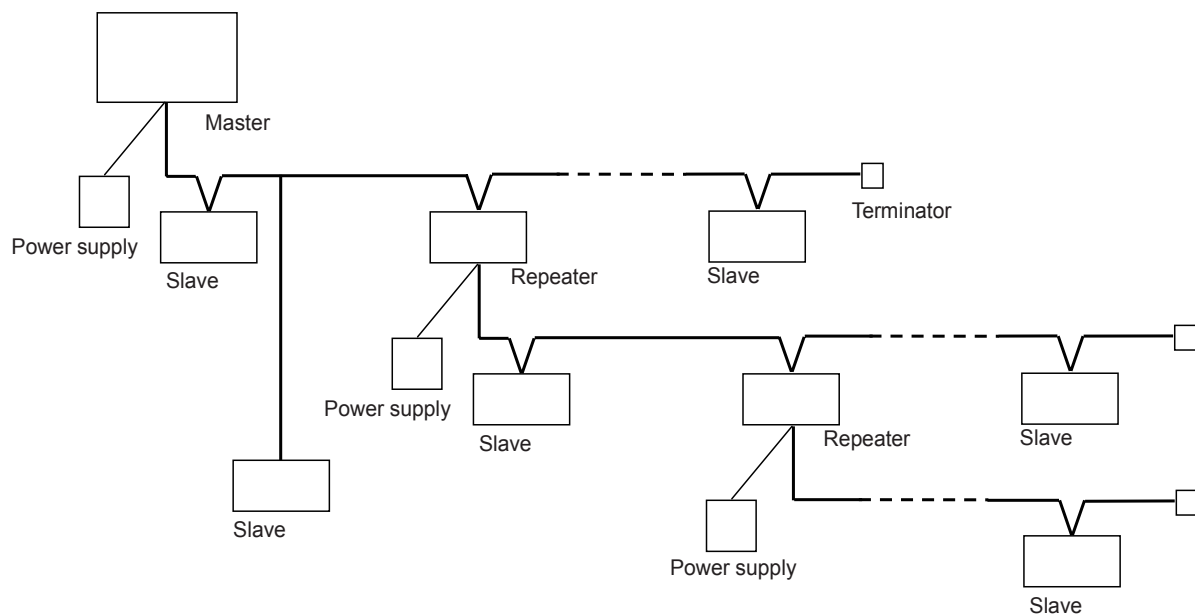

Figure 2 – CompoNet components

4.4 CompoNet communication model

The abstract object-oriented communication model of a node includes the following:

- **Unconnected message manager (UCMM):** processes unconnected explicit messages;
- **Identity object:** identifies and provides general information about the device;
- **Connection class:** allocates and manages internal resources associated with both I/O and explicit messaging connections;
- **Connection object:** manages the communication specific aspects associated with a particular application-to-application relationship;
- **CompoNet link object:** provides the configuration and status of a physical CompoNet CDI;
- **Message router:** forwards explicit request messages to the appropriate object;
- **Application objects:** implement the intended purpose of the product.

4.5 CompoNet and CIP

CompoNet upper layers use a subset of the Common Industrial Protocol (CIP™) and services specified in IEC 61158-5-2 and IEC 61158-6-2.

The relationships between CompoNet, CIP and the OSI reference model (ISO/IEC 7498-1) are shown in Table 2.

Table 2 – OSI reference model and CompoNet

ISO OSI	CompoNet
7	CIP
6	null
5	null
4	null
3	null
2	CompoNet time domain
1	CompoNet physical layer
0	cable and connector

5 Characteristics

5.1 Communication cycle

5.1.1 General

In a CompoNet network, the master controls bus communications according to its configuration. A master divides a communication cycle into several time domains or time slots.

5.1.2 Time domains

CompoNet conducts arbitration under strict time supervision managed by the master. The communication cycle is partitioned into time domains as shown in Figure 3. Each node obtains the right to send data to the network within a specified time period after the completion of the OUT time domain.

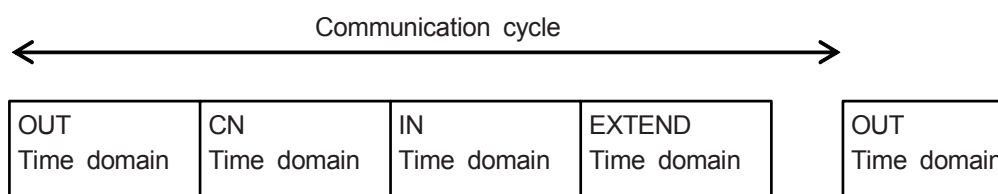

Figure 3 – Time domains

The first domain of each communication cycle is the OUT time domain. Subsequent domains are CN time domain, IN time domain, and EXTEND time domain.

- **OUT Time Domain:** the master sends an OUT frame or a TRG frame in this period.
- **CN Time Domain:** CN frames are sent in this period. The number of CN frames is set by the master.
- **IN Time Domain:** IN frames are sent in this period consecutively by all input type devices.
- **EXTEND Time Domain:** the master executes message communications in this period. Event frames, i.e. A_EVENT frames and B_EVENT frames, can be sent in this period. BEACON frames shall be sent periodically. The master can send a BEACON before every OUT time domain starts, or in an idle EXTEND time domain.

5.1.3 A typical communication cycle

The master sends an OUT frame first. Completion of the OUT frame triggers slaves and repeaters to start their timers. The slaves or repeaters addressed by the "CN Request MAC ID Mask" field in the OUT frame transmit their CN frames consecutively. This is followed by the IN frames from any IN devices in the Participated state, except for EventOnly substate, at a pre-defined time sequence (see Figure 4). Then, an event command frame and a possible immediate acknowledge frame may be transmitted on the bus, depending on the master scheduling. The master, slaves and repeaters can send an event command frame, and the node designated in the event command frame Destination MAC ID field sends an event acknowledge frame, if it is required.

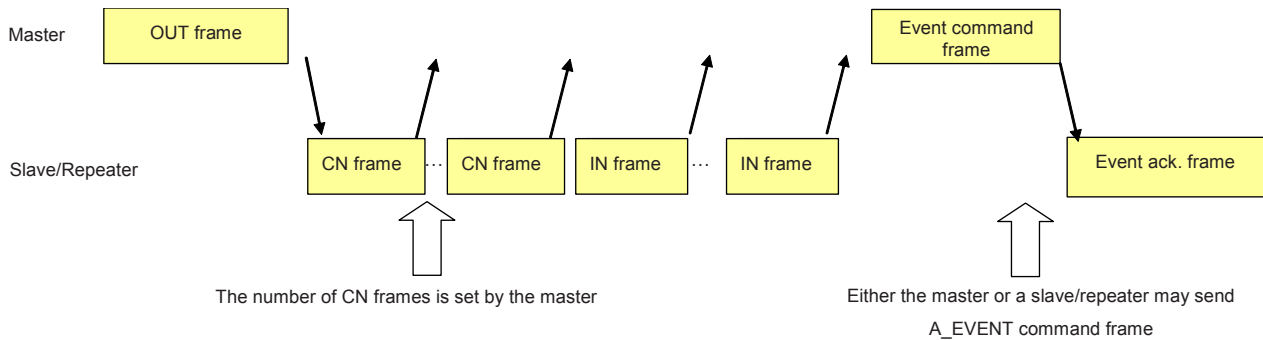

Figure 4 – A typical communication cycle

5.2 Messaging protocol

5.2.1 Message frame format

5.2.1.1 General

A typical message frame is composed of Preamble, Command Code, Command-Code-dependent block(s), and CRC, as shown in Figure 5.

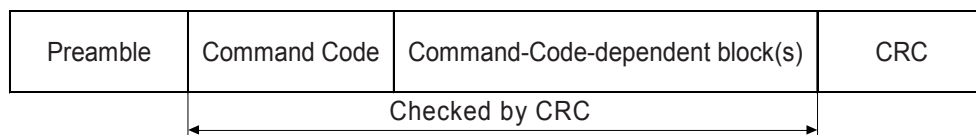

Figure 5 – A general frame

There are seven types of frames:

OUT	stands for <u>OUT</u> put data.
TRG	stands for <u>TRiG</u> ger.
CN	stands for <u>ConN</u> ection status.
IN	stands for Input data.
A_EVENT	stands for <u>A</u> pplication <u>E</u> VENT communication.
B_EVENT	stands for <u>B</u> ase memory <u>E</u> VENT communication.
BEACON	notification frame generated by the master.

Command Code definitions are presented in Table 3.

Table 3 – Command codes

Command code							Meaning
B0	B1	B2	B3	B4	B5	B6	
0	0	0	1	x	x	x	OUT
0	0	1	1	x	x	x	TRG
0	1	x	x	/			CN
1	0	/			/		IN
1	1	1	x	x	x	/	A_EVENT
1	1	0	x	x	x	/	B_EVENT
0	0	0	0	1	/		BEACON

All frames use the same Preamble.

Two types of CRC generator polynomials, CRC8 (8-bit) and CRC16 (16-bit), are used.

5.2.1.2 Preamble

The preamble part of a frame consists of 10 marks: 0011 1001 10. See Figure 6.

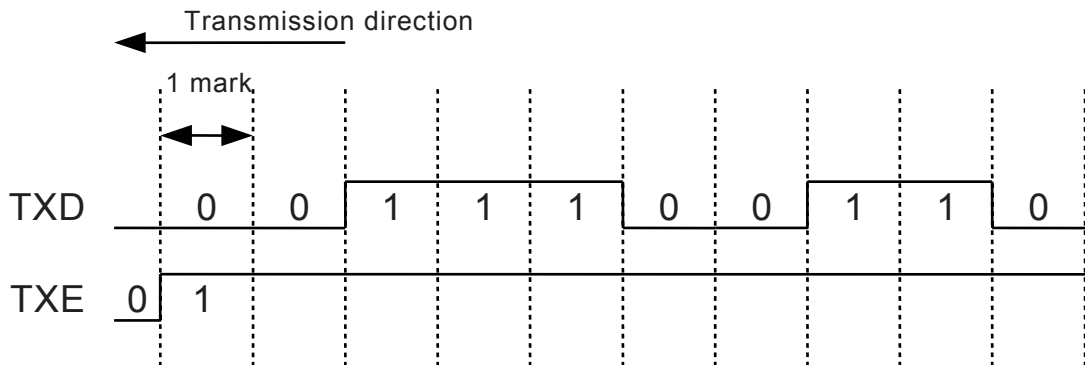

Figure 6 – Preamble of frames

5.2.1.3 CRC generator polynomials

2 types of CRC generator polynomials are used. See Figure 7 and Figure 8.

CRC8 employs the generator polynomial of $X^8 + X^7 + X^4 + X^3 + X + 1$

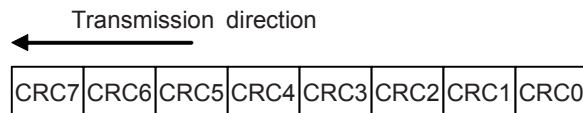

Figure 7 – Transmission direction

CRC16 uses CRC-CCITT, the generator polynomial is $X^{16} + X^{12} + X^5 + 1$.

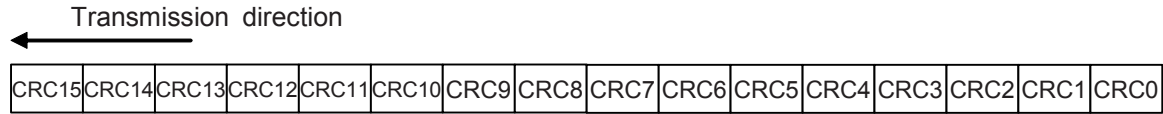

Figure 8 – Transmission direction

5.2.1.4 Transmission directions of command code and command-dependent block

The transmission directions are LSB first as described below:

- the transmission direction for the Command Code is LSB first, i.e. starts from B0;
- the transmission direction for MAC ID is LSB first;
- the transmission direction for the Length is LSB first;
- the transmission direction for the output data is LSB first. In other words, it starts from Word0_bit0 to Word0_bit15 and then the same for the following words;
- the transmission direction for A_EVENT data is LSB first. In other words, it starts from Word0_bit0 to Word0_bit15 and then the same for the following words;
- the transmission direction for B_EVENT data is LSB first. In other words, it starts from Word0_bit0 to Word0_bit15 and then the same for the following words.

5.2.1.5 Command restrictions for slave MAC

The following Table 4 provides a summary of network events and states in which the events are processed.

Table 4 – Command restrictions for slave MAC

MAC Function	Event	State				
		INIT	Offline or locked	Online	CommFault	EventOnly
Receive	OUT/TRG	No	Yes	Yes	Yes	Yes
	CN	No	No	No	No	No
	A_EVENT	No	No	Yes	No	Yes
	B_EVENT	No	Yes	Yes	No	Yes
	Poll (B_EVENT)	No	No	Yes	No	Yes
	IN	No	No	No	No	No
	BEACON	Yes	Yes	Yes	Yes	Yes
	CRC_OK_frame	Yes	Yes	Yes	No	Yes
Send	CN_frame	No	Yes	Yes	Yes	Yes
	IN_frame	No	No	Yes	No	No
	A_EVENT	No	No	Yes	No	Yes

The CRC_OK_frame event indicates that a frame with correct CRC has been received. The event is defined for use during Data Rate detection.

5.2.2 Message frame types

5.2.2.1 OUT frame

5.2.2.1.1 General

An OUT frame is a multicast message generated only by the master and sent to all slaves and repeaters on the network. OUT frames are used for the following purposes:

- OUT data is delivered from the master to all OUT slaves in one broadcast message;
- the addresses of nodes requested to send CN frames in the subsequent CN time domain are designated by this frame;
- after detecting the completion of an OUT frame, IN slaves latch their input data;
- slaves and repeaters start their internal timers when the completion of an OUT frame is detected. These internal timers are used to correctly participate in subsequent time domains in the communication cycle;
- upon detection of an OUT frame, each OUT slave consumes its output data from a preset position within the frame.

Figure 9 and Table 5 present the format and block description of OUT frame.

Preamble	Command code	CN Request MAC ID Mask	Length	OUT data	CRC16
5 bits	7 bits	9 bits	7 bits	0 bits to 1 280 bits	16 bits

Figure 9 – OUT frame format

Table 5 – Block name description

Block name	Bit count (bits)	Feature description
Command Code	7	Identifies this frame as an OUT frame.
CN Request MAC ID Mask	9	Used by slaves or repeaters to determine the MAC ID of the nodes requested to respond with a CN frame during the CN time domain.
Length	7	OUT data length (in words), Indicates 0 words to 80 words.
OUT data (OUT block N°0 to 79)	0 to 1 280	Indicates OUT data from the master to slaves. Indicates 0 points to 1 280 points (in 16 points).

5.2.2.1.2 Command code

Figure 10 presents the command code definition.

B0	B1	B2	B3	B4	B5	B6
0	0	0	1	I/O Refresh	CN Target	

Figure 10 – OUT command code

CN Target: The master uses these parameters as shown in Table 6 to select which nodes are to reply with a CN frame.

Table 6 – CN target

CN Target		
B5	B6	Description
1	0	Nodes in the participated state
0	1	Nodes in the non-participated state
1	1	Nodes in the Communication Fault state
0	0	Prohibits from sending CN_frame

I/O Refresh: If the I/O refresh bit (see Table 7) is clear (0), no IN frames are sent to the master from slaves. The output data in the OUT frame are not to be consumed by slaves.

Table 7 – I/O refresh

I/O Refresh	
B4	Description
0	Disable I/O refreshing
1	Enable I/O refreshing

5.2.2.1.3 CN request MAC ID mask

Nodes with the same upper bits of the CN Request MAC ID Mask send CN frames in ascending order of their lower bits.

For example, if the CnFrameAddressMask value in the STW is 4 (16 CN frames per CN time domain) and this value is 48, nodes whose MAC ID range 48 to 63 respond with CN frames.

5.2.2.1.4 Length

This is the output data length ranged from 0 to 80 in words.

5.2.2.1.5 Output data

Output data is sent for consuming slaves. It is always sent in multiples of words.

For word slaves, the “OutBlockPointer[6:0]” set by STW from the master decides where the output data is located in the frame. For example, value 3 of “OutBlockPointer[6:0]” means the slave output data is from word position 3 of “Output Data” in OUT frames. The number of words of output data that the slave consumes is reported in the “OutloModeStatus” parameter of the STR.

For bit slaves, a combination of the “OutBlockPointer[6:0]” set by STW from the master and its address determines the location of device’s data in the output data. One word of output data corresponds to a group of eight, bit-slave node addresses (2 bits for each address). The lower 3 bits of the node address correspond to the output data position in the word. For example, if the address of three LSB is “001”, bit 2 in the word pointed by “OutBlockPointer[6:0]” is the starting address of the device’s data.

The application can only apply output data received from OUT frames after the slave has been allocated by the master.

5.2.2.2 TRG frame

5.2.2.2.1 General

A TRG frame functions in a similar manner as an OUT frame except that it does not deliver any output data. It can be generated only by the master. It has following purpose and meaning:

- it designates the addresses of the nodes that are to send CN frames;
- after the completion of a TRG frame is detected, IN slaves latch their input data;
- after the completion of a TRG frame is detected, the indicated slaves and repeaters start their internal timers. The expected CN frames and IN frames are sent successively.

Figure 11 and Table 8 present the format and block description of TRG frame.

Preamble	Command code	CN request MAC ID mask	CRC8
5 bits	7 bits	9 bits	8 bits

Figure 11 – TRG frame format

Table 8 – Block name description

Block name	Bit count (bits)	Feature
Command	7	Identifies this frame as a TRG frame.
CN Request MAC ID Mask	9	Used by slaves or repeaters to determine the MAC ID of the nodes requested to respond with a CN frame during the CN time domain.

5.2.2.2.2 Command code

Figure 12 presents the command code definition.

B0	B1	B2	B3	B4	B5	B6
0	0	1	1	I/O Refresh	CN Target	

Figure 12 – TRG command code

CN Target: See 5.2.2.1.2

I/O Refresh: See 5.2.2.1.2

5.2.2.2.3 CN request MAC ID mask

See 5.2.2.1.3

5.2.2.3 CN frame

5.2.2.3.1 General

A CN frame is used by slaves and repeaters to notify the master of their status. The “CN Request MAC ID Mask” in an OUT frame or TRG frame designates a group of nodes that are to report their status. The number of CN frames sent is specified by the master during configuration.

Additionally, slaves can use a CN frame to notify the master of a request to send an event. CN frames can be transmitted only by slaves and repeaters.

Figure 13 and Table 9 present the format and block description of CN frame.

Preamble	Command code	Source MAC ID	Status	CRC8
5 bits	4 bits	9 bits	4 bits	8 bits

Figure 13 – CN frame format

Table 9 – Block name description

Block name	Bit Count (bits)	Feature
Command Code	4	Identifies this frame as a CN frame
Source MAC ID	9	Indicates CN frame source MAC ID
Status	4	Indicates application status

5.2.2.3.2 Command code

Figure 14 presents the command code definition.

B0	B1	B2	B3
0	1	Duplicate check function status	A_EVENT sending request

Figure 14 – CN command code

Duplicate check function status:

A slave or repeater reports its duplicate MAC ID check function by this bit.

If the bit is reset for a non-participated node, the duplicate MAC ID check is active. In this state, the CN counter in the node increases after each CN frame sent by the node without having received an STW. If the counter reaches 16 without transitioning to the Participated state the node goes to the Communication Fault state.

This bit is ignored when sent from nodes in the Participated state.

The CN counter can be stopped by a “**STW_Standby Locked**” operation (see 5.4.3). A locked node reports this bit with “1”. See Table 10.

Table 10 – Duplication checking function status

B2	Description
0	Duplicate MAC ID check active
1	Duplicate MAC ID check inactive

A_EVENT sending request:

A slave or repeater uses this bit to inform the master if it needs to send an A_EVENT frame. See Table 11.

Table 11 – A_EVENT sending request

B3	Description
1	Need to send an A_EVENT
0	No request for sending A_EVENT

5.2.2.3.3 Source MAC ID

This is the 9-bit MAC ID of the node.

5.2.2.3.4 Status

A slave or repeater uses these bits to report warning and alarm status of applications to the master. As shown in Table 12, reserved 2 bits shall be reset to “0”.

Table 12 – Status of CN frames

B0	B1	B2	B3
Warning	Alarm	Reserved	

Warning: This bit is set to “1” when some error such as maintenance need occurs. This kind of situation can possibly lead to a problem. See Table 13.

Table 13 – Warning bit of CN frames

B0	Description
1	True
0	False

Alarm: This bit is set to “1” when some critical error such as Non-volatile memory malfunction is detected. See Table 14.

Table 14 – Alarm bit of CN frames

B1	Description
1	True
0	False

5.2.2.4 IN frame

5.2.2.4.1 General

An IN frame is generated only by slaves which send input to the master. See Figure 15 and Table 15.

Preamble	Command code	Source MAC ID	Length	IN data	CRC8
5 bits	2 bits	9 bits	5 bits	2 bits to 256 bits	8 bits

Figure 15 – IN frame format

Table 15 – Block name description

Block name	Bit count (bits)	Feature description
Command	2	Identifies this frame as an IN frame.
Source MAC ID	9	Indicates IN data source MAC ID.
Length	5	Coded length in 5 bits indicates 2, 4, 8, 16, 32, 48, ..., 256 bits of input data.
IN data	2 to 256	IN frame for Word slave: 8 points to 256 points of IN data. IN frame for Bit slave: IN data is fixed as 2 bits or 4 bits.

5.2.2.4.2 Command code

Figure 16 presents the command code definition.

B0	B1
1	0

Figure 16 – IN command code

5.2.2.4.3 Source MAC ID

This is the MAC ID of a slave which produces input data.

5.2.2.4.4 Length

Table 16 presents the encoded length definition.

Table 16 – Encoded length

B0	B1	B2	B3	B4	Description
0	0	0	0	0	2 bits
1	0	0	0	0	4 bits
0	1	0	0	0	8 bits
1	1	0	0	0	16 bits
0	0	1	0	0	32 bits
					... (increment of 16 bits)
0	1	0	0	1	256 bits
1	1	0	0	1	Reserved
					...
1	1	1	1	1	Reserved

5.2.2.4.5 Input data

The length of input data shall be the same as indicated by “length” of the frame.

5.2.2.5 A_EVENT frame

5.2.2.5.1 General

The A_EVENT frame is used to execute explicit message communication for the application layer. A_EVENT frames can be transmitted by all devices. They are used for the following purposes:

- event communications between the master and a slave or a repeater.
- event communications between slaves and repeaters. This is realized by the master acting as an intermediary or proxy for the requesting client. The request message is forwarded by the master to the server and the server response is forwarded back to the initiating client.

Figure 17 and Table 17 present the format and block description of A_EVENT frame.

Preamble	Command code	Destination MAC ID	Source MAC ID	Length	Event data	CRC16
5 bits	6 bits	9 bits	9 bits	5 bits	0 bits to 352 bits	16 bits

Figure 17 – A_EVENT frame format

Table 17 – Block name description

Block name	Bit Count (bits)	Feature description
Command	6	Identifies this frame as an A_EVENT frame
Destination MAC ID	9	Indicates event data destination MAC ID
Source MAC ID	9	Indicates event data source MAC ID
Length	5	Indicates 0 words to 22 words of event data length (in word). Use of 23 to 31 is illegal
Event data	0 to 352	Event data of 0 words to 22 words

Event communication is executed during the EXTEND time domain.

5.2.2.5.2 Command code

Figure 18, Table 19 and Table 20 present the command code definition.

B0	B1	B2	B3	B4	B5
1	1	1	Acknowledgement	Command type	

Figure 18 – A_EVENT command code

Acknowledgement: If the bit is set, a receiver shall acknowledge back to an A_EVENT request. In acknowledgement frames to A_EVENT requests, the bit shall be clear. In A_EVENT request frames, the bit shall be set.

Table 18 – Acknowledgement bit of A_EVENT

B3	Description
0	No acknowledgement is required
1	An Acknowledgement is required

Command Type: This part of the code is used to indicate whether the command is a request or an acknowledgement. A positive acknowledgement means a full command has been received and for processing by the receiver. It does not mean that the receiver accepted the command. A negative acknowledgement means the receiver cannot receive the command at the moment. The originator may schedule a retry later.

Table 19 – Command type of A_EVENT

B4	B5	Description
0	0	This command is a request
1	0	Positive Acknowledgement
1	1	Negative Acknowledgement, the receiver is in busy state
0	1	Reserved

5.2.2.5.3 Destination MAC ID and source MAC ID

Either the destination MAC ID or the source MAC ID shall be the master MAC ID for any one of A_EVENT frames.

For an A_EVENT frame sent by a slave or a repeater, the destination MAC ID is the master MAC ID.

For an A_EVENT frame sent by the master, the source MAC ID is the master MAC ID.

5.2.2.5.4 Length

This part indicates the event data length in 0 words to 22 words. Values 23 through 31 are illegal.

For an acknowledgement, this shall be 0.

5.2.2.5.5 A_EVENT data

A_EVENT data has a maximum of 22 words per frame. The data is used for explicit messages. The formats are defined in 5.2.3.2.

When the addresses of explicit message source and destination in the A_EVENT data are not identical with the source and destination MAC ID, the A_EVENT is processed by a master proxy.

For an acknowledgement, there shall be no data.

5.2.2.6 B_EVENT frame

5.2.2.6.1 General

The B_EVENT frame is an event communication frame only for the Data Link Layer. Each node has its own data link settings and parameters. The B_EVENT is used by the master to get or to set these data-link related settings and parameters. Also, the master uses B_EVENT frame to allow a slave or repeater to send A_EVENT. Figure 19 and Table 20 present the format and block description of B_EVENT frame.

Preamble	Command code	Destination MAC ID	Source MAC ID	Length	Event data	CRC16
5 bits	6 bits	9 bits	9 bits	5 bits	16 bits to 352 bits	16 bits

Figure 19 – B_EVENT frame format

Table 20 – Block name description

Block name	Bit Count (bits)	Feature description
Command	6	Identifies this frame as a B_EVENT frame.
Destination MAC ID	9	Indicates destination MAC ID.
Source MAC ID	9	Indicates event data source MAC ID.
Length	5	Indicates 1 words to 22 words of event data length.
Event data	16 to 352	Event data of 1 words to 22 words.

B_EVENT frame is also used in the detection of a duplicate MAC ID and other node operations.

5.2.2.6.2 Command code

Figure 20, Table 21 and Table 22 present the command code definition.

B0	B1	B2	B3	B4	B5
1	1	0	Acknowledgement	Command type	

Figure 20 – B_EVENT command code meanings

Acknowledgement: If the bit is set, a receiver shall acknowledge back to a B_EVENT request. In acknowledgement frames to B_EVENT requests, or “A_EVENT Poll Request” frames, the bit shall be clear. In B_EVENT request frames, the bit shall be set.

Table 21 – Acknowledgement bit of B_EVENT

B3	Description
0	No acknowledgement is required
1	An acknowledgement is required

Command type:

Table 22 – Command type of B_EVENT

B4	B5	Description
0	0	This command is a request for a participated node
1	0	Positive Acknowledgement
1	1	Negative Acknowledgement, the receiver is in busy state
0	1	This command is a request for a non-participated node

5.2.2.6.3 Destination MAC ID and source MAC ID

Either the destination MAC ID or the source MAC ID shall be the master MAC ID for all B_EVENT frames.

For a B_EVENT frame sent by a slave or a repeater, the destination MAC ID is the master MAC ID.

For a B_EVENT frame sent by the master, the source MAC ID is the master MAC ID.

5.2.2.6.4 Length

This part indicates the event data length ranging from 1 word to 22 words. The value 0 as well as values 23 through 31 is illegal.

This length is “1” for STR request, STW response and A_EVENT Poll Request.

5.2.2.6.5 B_EVENT data

5.2.2.6.5.1 General

Figure 21, Figure 22 and Table 23 present the format and block description of B_EVENT frame.

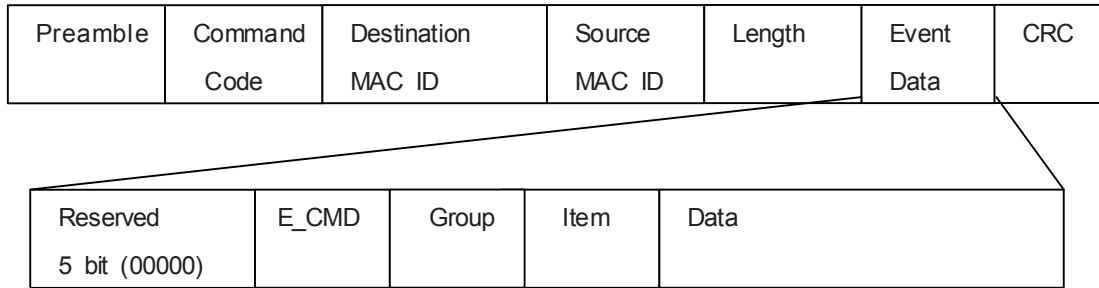

Figure 21 – B_EVENT message format

E_CMD:

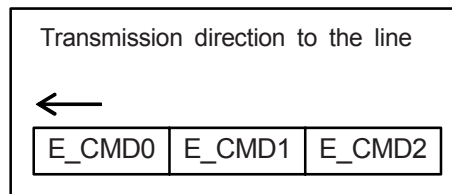

Figure 22 – E_CMD block

Table 23 – E_CMD block meanings

E_CMD0	E_CMD1	E_CMD2	Meaning
0	0	0	Read Request / Response
0	0	1	Write Request / Response
0	1	0	RESERVED
0	1	1	
1	0	0	A_EVENT Poll Request
1	0	1	RESERVED
1	1	0	
1	1	1	

NOTE The content of service is decided in E_CMD block in B_EVENT.

Group: This part shall be set to “1” for STR, “2” for STW, and “0” for A_EVENT Poll Request as shown in Figure 23 and Table 24:

- Group 1: Network status
- Group 2: Configuration
- Group 3: Obsolete
- Group 4 to Group 7: Reserved, and
- Group 0: A_EVENT Poll Request

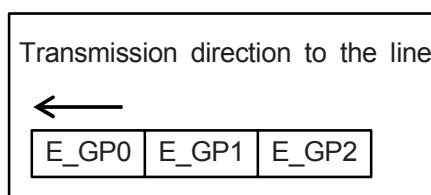

Figure 23 – Group block

Table 24 – Group block meanings

E_GP0	E_GP1	E_GP2	Meaning
0	0	0	A_EVENT Poll Request
1	0	0	Network status
0	1	0	Configuration
1	1	0	Obsolete
0	0	1	RESERVED
1	0	1	
0	1	1	
1	1	1	

Item: This shall be set to “31” for STR and STW, and “0” for A_EVENT Poll Request as shown in Figure 24 and Table 25:

- Item 31: STR or STW operation
- Item 1 to Item 21: Obsolete
- Item 0: A_EVENT Poll Request
- Others: Reserved

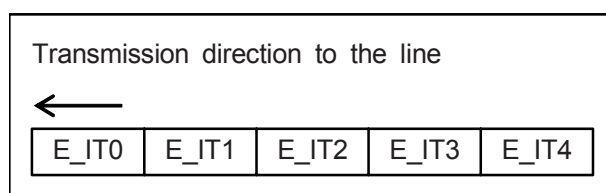

Figure 24 – Item block

Table 25 – Item block meanings

E_IT0	E_IT1	E_IT2	E_IT3	E_IT4	Meaning
0	0	0	0	0	A_EVENT Poll Request
1	0	0	0	0	Obsolete
0	1	0	0	0	
1	1	0	0	0	
0	0	1	0	0	
1	0	1	0	0	
0	1	1	0	0	
1	1	1	0	0	
0	0	0	1	0	
1	0	0	1	0	

E_IT0	E_IT1	E_IT2	E_IT3	E_IT4	Meaning	
0	1	0	1	0		
1	1	0	1	0		
0	0	1	1	0		
1	0	1	1	0		
0	1	1	1	0		
1	1	1	1	0		
0	0	0	0	1		
1	0	0	0	1		
0	1	0	0	1		
1	1	0	0	1		
0	0	1	0	1		
1	0	1	0	1		
0	1	1	0	1		Reserved
1	1	1	0	1		
0	0	0	1	1		
1	0	0	1	1		
0	1	0	1	1		
1	1	0	1	1		
0	0	1	1	1		
1	0	1	1	1		
0	1	1	1	1		
1	1	1	1	1		
1	1	1	1	1	STR or STW operation	

Data: Group 1, Group 2 and Group 0 data structures are specified.

5.2.2.6.5.2 Network status group

Commands (E_CMD) other than READ are prohibited in this area. Access to this group is called "Status Reading", abbreviated STR. Figure 25 presents the STR definition.

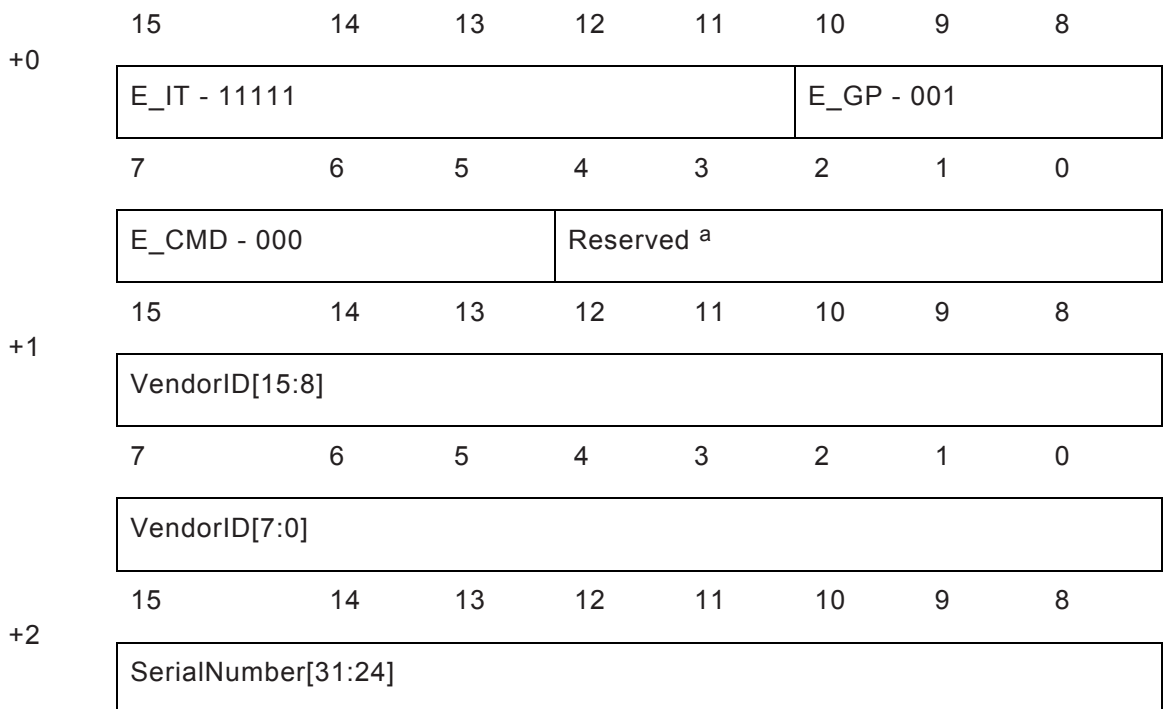

Figure 25 (continued overleaf)

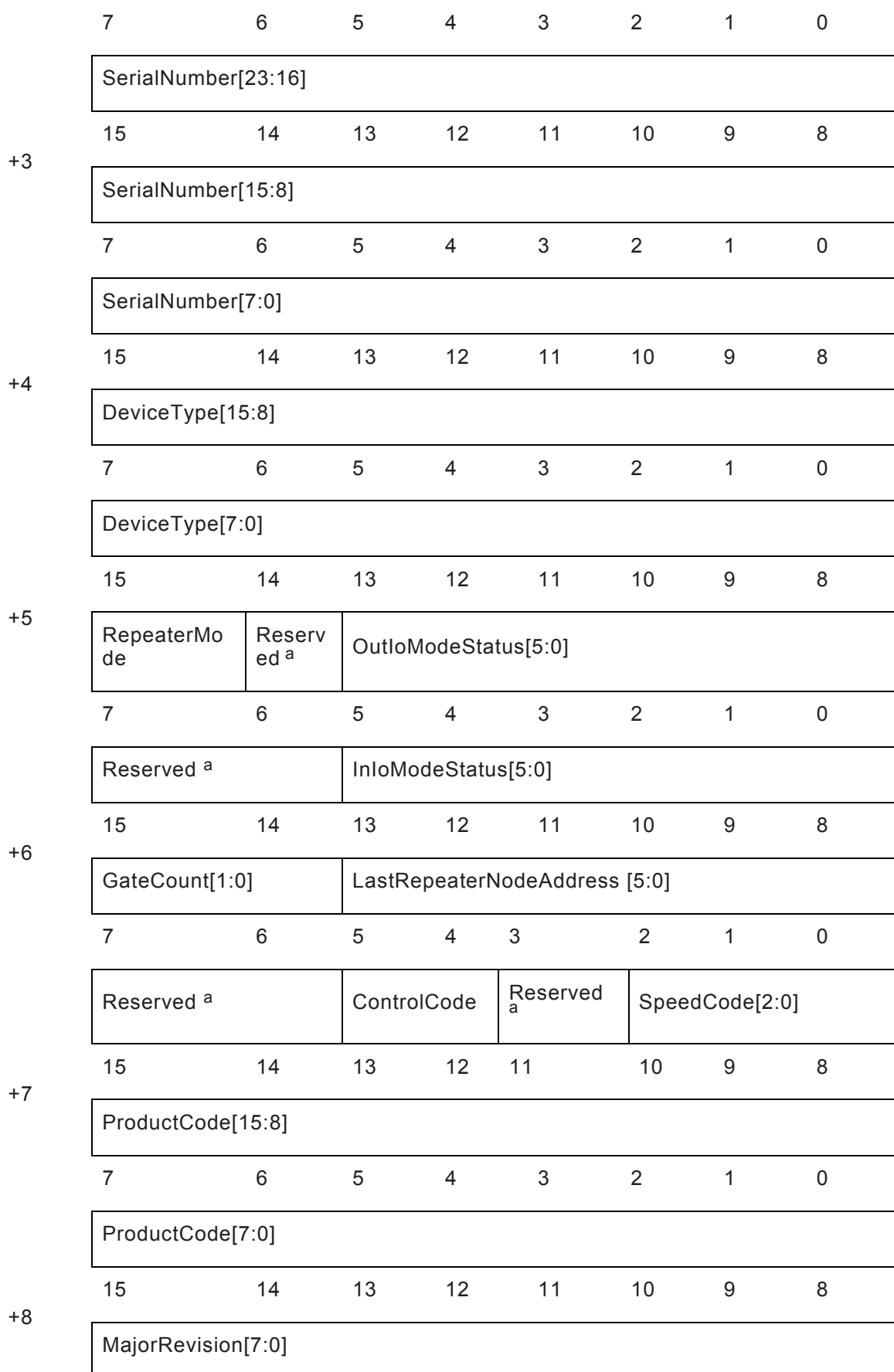

Figure 25 (continued overleaf)

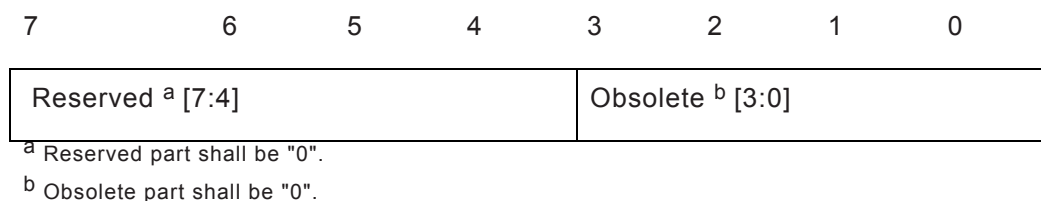

Figure 25 – Status Read (STR Response) event data

STR field data

- a) VendorID: Vendor ID attribute of the Identity Object as assigned by ODVA
- b) SerialNumber: Serial Number attribute of Identity Object
- c) DeviceType: Device Type attribute in the Identity Object as defined by ODVA
- d) RepeaterMode: True/False
- e) InIoModeStatus: Coded-length of input data and status
 - 1) InIoModeStatus[5]:
 - 1: InIoModeStatus[4:0] indicates size of input data
 - 0: no input data
 - 2) InIoModeStatus[4:0]:
 - 00000: 2 points; 00001: 4 points; 00010: 8 points; 00011: 16 points
 - 00100: 32 points; 00101: 48 points; 00110: 64 points; 00111: 80 points;
 - 01000: 96 points; 01001: 112 points; 01010: 128 points; 01011: 144 points;
 - 01100: 160 points; 01101: 176 points; 01110: 192 points; 01111: 208 points;
 - 10000: 224 points; 10001: 240 points; 10010: 256 points; others: reserved
- f) OutIoModeStatus: Coded-length of output data and status
 - 1) OutIoModeStatus[5]:
 - 1: OutIoModeStatus[4:0] indicates size of output data
 - 0: no output data
 - 2) OutIoModeStatus[4:0]:
 - 00000: 2 points; 00001: 4 points; 00010: 8 points; 00011: 16 points
 - 00100: 32 points; 00101: 48 points; 00110: 64 points; 00111: 80 points;
 - 01000: 96 points; 01001: 112 points; 01010: 128 points; 01011: 144 points;
 - 01100: 160 points; 01101: 176 points; 01110: 192 points; 01111: 208 points;
 - 10000: 224 points; 10001: 240 points; 10010: 256 points; others: reserved
- g) GateCount: 0, 1, 2; the number of repeaters between the master and the node; 2 is not valid for a repeater.
- h) Control Code: Control Code value from the most recent BEACON frame
- i) LastRepeaterNode Address: Repeater address, a copy from BEACON frame
- j) SpeedCode: 0: 93,75 kbit/s; 1: reserved; 2: 1,5 Mbit/s; 3: 3 Mbit/s; 4: 4 Mbit/s.
- k) ProductCode: Product Code attribute in the Identity Object.
- l) MajorRevision: Major Revision attribute in the Identity Object

5.2.2.6.5.3 Configuration group

Access to this group is called “Status Writing”, abbreviated as STW. Read command to this area is not allowed. Figure 26 presents STW definition.

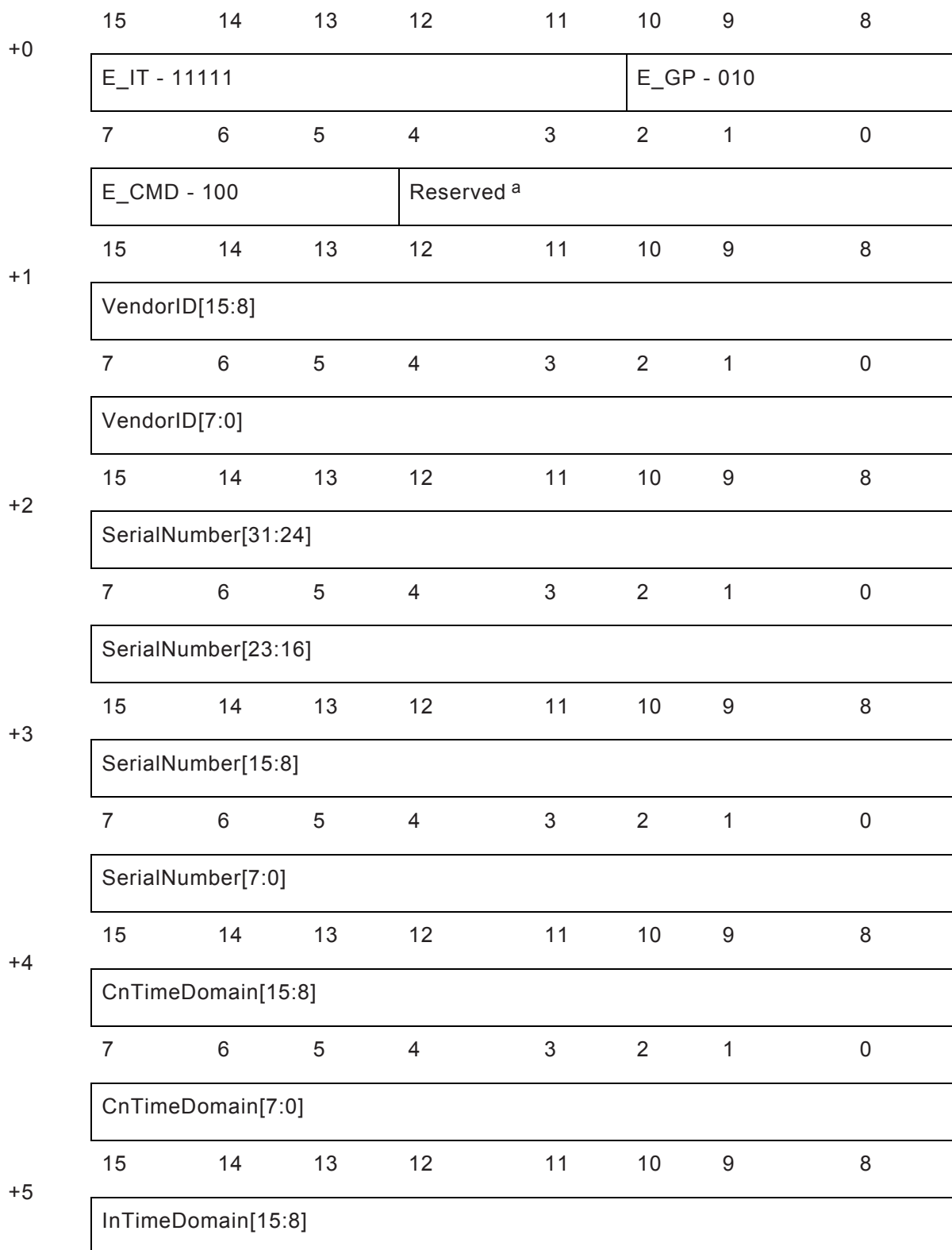
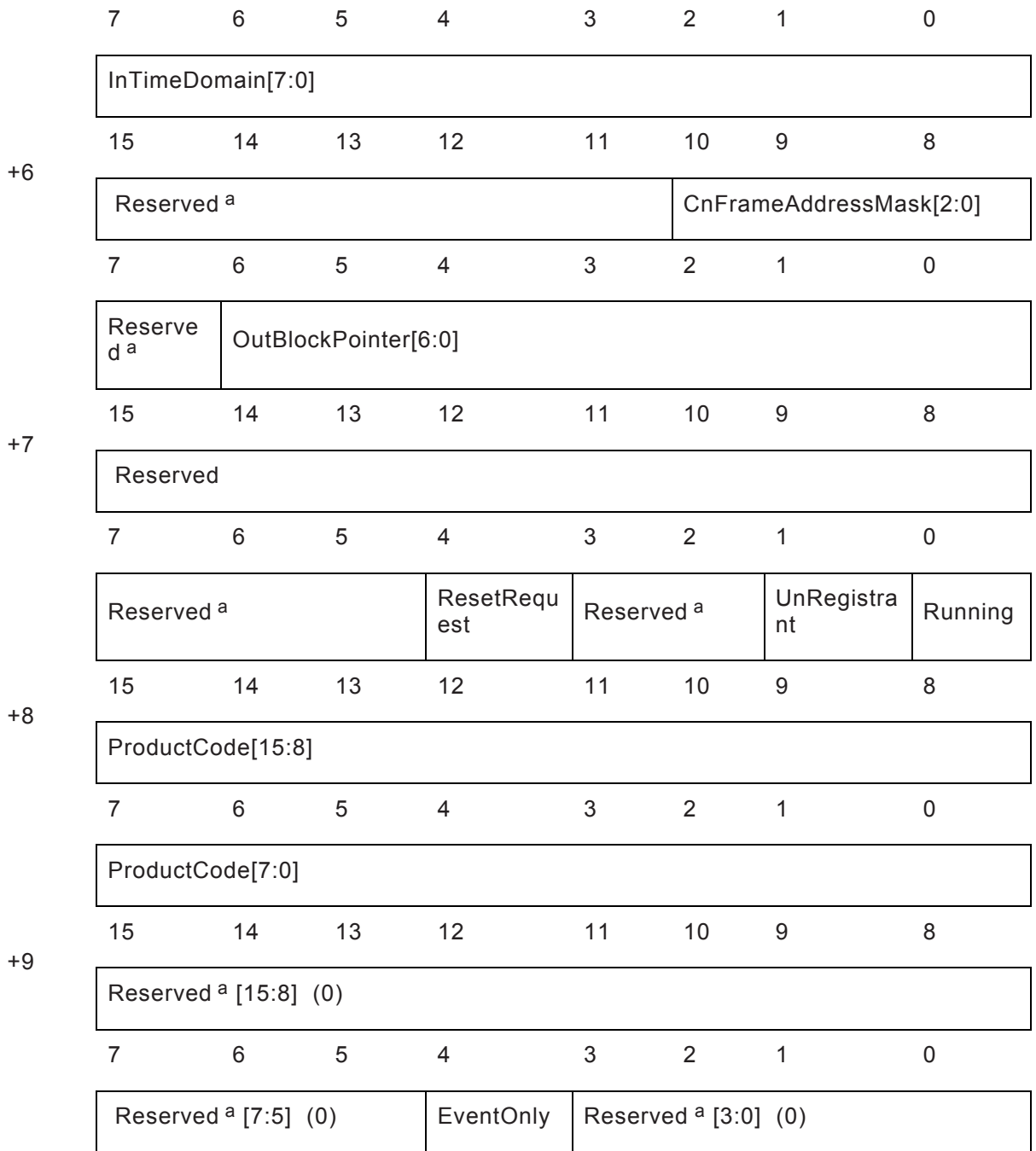

Figure 26 (continued overleaf)



^a Reserved part shall be "0".

Figure 26 – Configuration event data (STW Request)

STW field data

- a) VendorID: Vendor ID attribute of the Identity Object as assigned by ODVA. Normally a copy from STR result is used.
- b) SerialNumber: Serial Number attribute of Identity Object. Normally a copy from STR result is used.
- c) CnTimeDomain: Mark count. This data is set by the master. When a node becomes "Participated", it shall reply a CN frame according to this setting.

- d) InTimeDomain: Mark count. This data is valid for IN and MIX slaves. When a node becomes “Participated” (excluding EventOnly state), it shall transmit an IN frame according to this setting.
- e) CnFrameAddressMask: This data is valid for “Participated” nodes. It indicates the CN frame number after an OUT or TRG frame, which requests “Participated” node CN frames.
- **0:** means 1 CN_Frame after an OUT or TRG frame. The Node with MAC ID identified by the “CN Request MAC ID” sends a CN.
 - **1:** means 2 CN_Frames after an OUT or TRG frame. The Node with the upper 8 bits of it’s MAC ID corresponding to the upper 8 bits of the “CN Request MAC ID” in an OUT or TRG sends a CN.
 - **2:** 4 CN_Frame, upper 7 bits of the MAC ID are compared.
 - **3:** 8 CN_Frame, upper 6-bits of the MAC ID are compared.
 - **4:** 16 CN_Frame, upper 5-bits of the MAC ID are compared.
 - **5:** 32 CN_Frame, upper 4-bits of the MAC ID are compared.
 - **6,7:** behave same as value 0
- f) OutBlockPointer: 0 to 79. It indicates output slaves where they pick out output data from OUT frame. 5.2.2.1.5.
- g) ResetRequest: Reset the node similar to power cycle.
- h) UnRegistrant: Enable/Disable duplicate address check function. 0: Enable; 1: Disable. When it is disabled, the node stops the CN counter, so it does not go to duplicate error state when the counter value reaches 15.
- i) Running: 0: to Non-participated; 1: to Participated
- j) ProductCode: Product Code attribute in the Identity Object. Normally a copy from STR result is used. This data is ignored by the receiver.
- k) EventOnly: If this is set to “1”, the node does not send an IN frame after it receives an OUT or TRG frame.

5.2.2.6.5.4 A_EVENT Poll Request Group

The A_EVENT Poll Request format is shown in Figure 27.

Word Offset	15	14	13	12	11	10	9	8
+0	Group=0					Item=0		
	7	6	5	4	3	2	1	0
	E_CMD=1				0			

Figure 27 – Poll data

5.2.2.6.6 B_EVENT frame decoding process

When a B_EVENT frame is received, it is first decoded as shown in Figure 28 This is to see whether the received frame is a STR, STW or A_EVENT Poll request.

If it is an STR request, it is processed according to the rules in Table 26.

If it is an A_EVENT Poll request, it is processed according to the rules in Table 27.

If it is an STW request, it is processed according to the rules in Table 28. If the STW request passes these checks, the B_EVENT Data in the STW request shall overwrite the configuration parameters listed in Figure 26. Processing then follows the flow chart shown in Figure 29. The STW commands used in the flow chart are defined in Table 29.

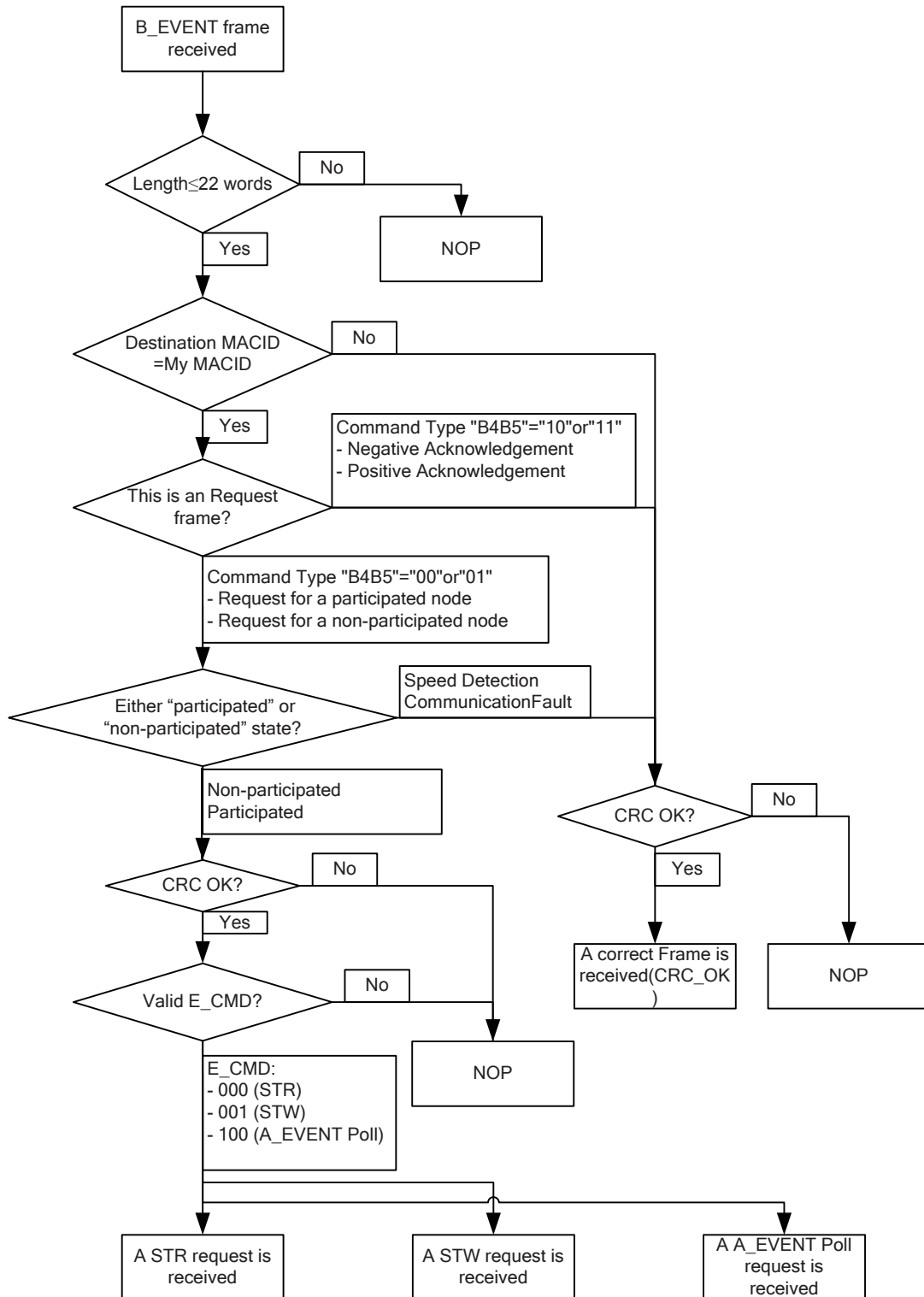

Figure 28 – B_EVENT general decoding phase

Table 26 – Processing rules for a STR request

Condition				Action	
Command code			My state	Receive buffer	Response
B3	B4	B5			
1	0	-	-	Busy	Negative acknowledgement
0	0	-	-	Busy	No acknowledgement
1	0	1	Non_participated	Free	Positive acknowledgement with Event Data
0	0	1	Non_participated	Free	No acknowledgement
-	0	1	Participated	Free	No acknowledgement
-	0	0	Non_participated	Free	No acknowledgement
1	0	0	Participated	Free	Positive acknowledgement with Event Data
0	0	0	Participated	Free	No acknowledgement
-:don't care					

Table 27 – Processing rules for an A_EVENT poll request

Condition				Action	
Command code			My state	Send buffer	Acknowledgement
B3	B4	B5			
1	-	-	-	-	No acknowledgement
-	-	-	Non_participated	-	No acknowledgement
0	0	1	Participated	-	No acknowledgement
0	0	0	Participated	No A_EVENT	No acknowledgement
0	0	0	Participated	A_EVENT is ready	A_EVENT is sent out
-:don't care					

Table 28 – Processing rules for a STW request

Condition					Action			
Command code			Vender ID/ serial number	My state	Receive buffer	Acknowledgement	B_EVENT data	State transition
B3	B4	B5						
1	0	-	_ a	_ a	Busy	Negative acknowledgement	Discard	No transition
0	0	-	_ a	_ a	Busy	No acknowledgement	Discard	No transition
1	0	1	Matched	Non-participated	Free	Positive acknowledgement	Overwrite	See Figure 29
0	0	1	Matched	Non-participated	Free	No acknowledgement	Overwrite	See Figure 29
-	0	1	Mismatched	Non-participated	Free	No acknowledgement	Discard	Transition to Communication Fault
-	0	1	_ a	Participated	Free	No acknowledgement	Discard	No transition
-	0	0	_ a	Non-participated	Free	No acknowledgement	Discard	No transition
1	0	0	Matched	Participated	Free	Positive acknowledgement	Overwrite	See Figure 29
0	0	0	Matched	Participated	Free	No acknowledgement	Overwrite	See Figure 29

Condition				Action				
Command code			Vender ID/ serial number	My state	Receive buffer	Acknowledgement	B_EVENT data	State transition
B3	B4	B5						
-	0	0	Mismatched	Participated	Free	No acknowledgement	Discard	Transition to Communication Fault

^a The hyphen "-" means "Don't care".

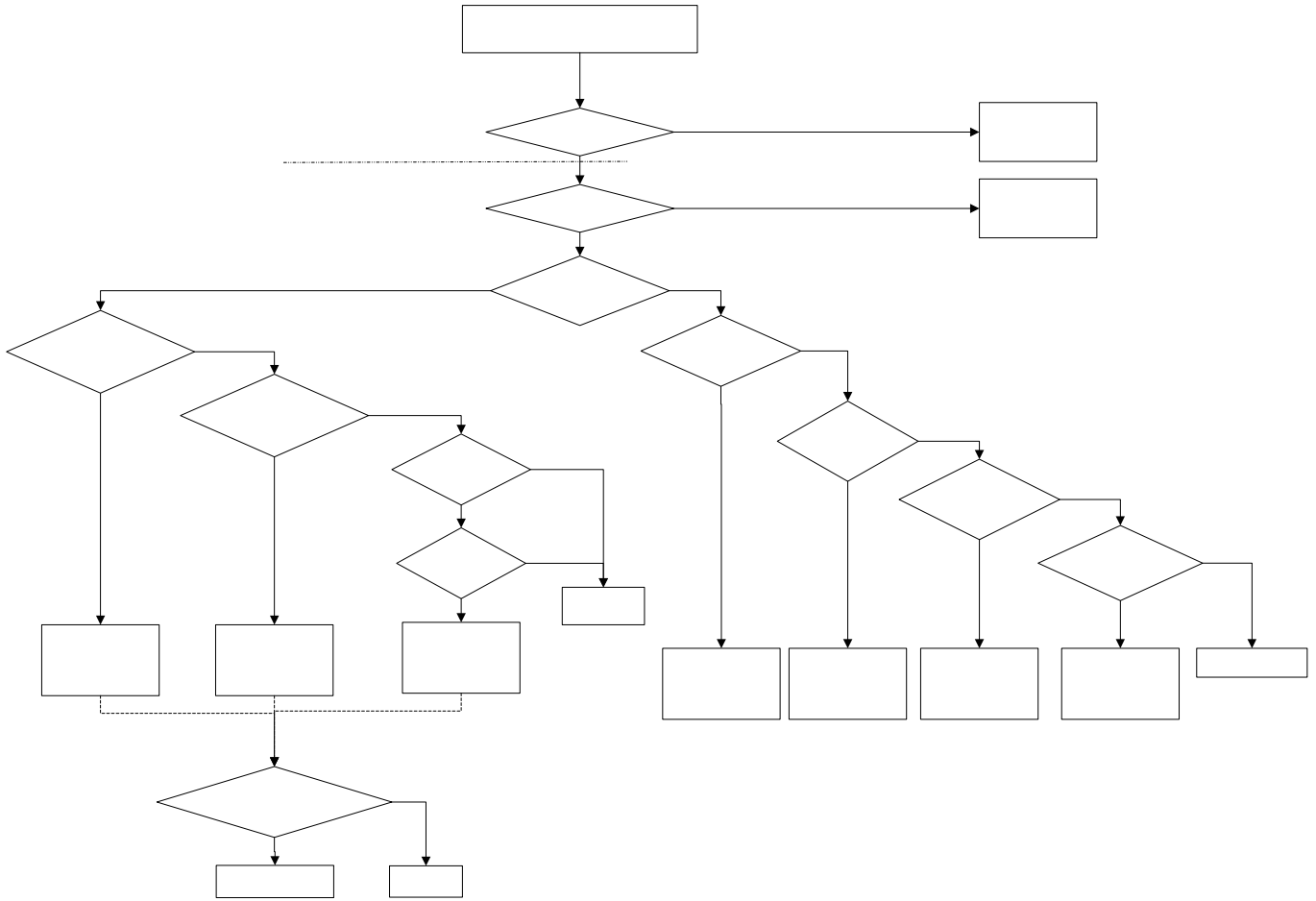

Figure 29 – Flow chart for processing a matched STW request

Table 29 – STW request commands

STW request commands	Running ^a	UnRegistrant ^a	Reset request ^a	EventOnly ^a	Reserved ^a
STW_Standby Offline ^b	0	0	0	0	0
STW_Reset ^b	0	0	1	0	0
STW_Standby Locked ^b	0	1	0	0	0
STW_Run Online ^b	1	0	0	0	0
STW_Run EventOnly ^b	1	0	0	1	0
^a See 5.2.2.6.5.					
^b See 5.4.2 and Figure 29.					

5.2.2.7 BEACON frame

5.2.2.7.1 General

BEACON frames are generated by the master to notify slaves and repeaters of the present transmission speed and network connection information. Figure 30 and Table 30 present the format and block description of BEACON frame.

At least one BEACON shall be sent every 250 ms.

Preamble	Command Code	Control Code	Speed Code	Last Repeater Node Address	Gate Counter	CRC8
5 bits	5 bits	2 bits	3 bits	6 bits	2 bits	8 bits

Figure 30 – BEACON frame format**Table 30 – Block name description**

Block name	Bit count (bits)	Feature description
Command Code	5	Identifies this frame as a BEACON frame.
Control Code	2	Number of CN frames allowed during the CN time domain.
Speed Code	3	Indicates the code of transmission speed.
Last Repeater Node Address	6	Indicates the last repeater address that this frame passed through.
Gate Count	2	Indicates the number of repeaters that this frame passed through.

5.2.2.7.2 Command code

Figure 31 presents the command code definition.

B0	B1	B2	B3	B4
0	0	0	0	1

Figure 31 – BEACON command code

5.2.2.7.3 Control code

Control Code declares the number of CN frames in one bus cycle. This is only valid for non-participated nodes. A Communication Fault node uses the value received when the node is in the Non-participated state. Table 31 presents the Control Code definition.

Table 31 – Control code of BEACON frames

B0	B1	Mask Address (Hex)	Meaning
0	0	03	4 CN_frames after an OUT or a TRG frame. The Node whose the upper 7 bits of MAC ID corresponds to the upper 7 bits of the “CN Request MAC ID” in an OUT or a TRG sends a CN frame.
1	0	07	8 CN_frames after an OUT or a TRG frame. The Node whose upper 6 bits of MAC ID corresponds to the upper 6 bits of the “CN Request MAC ID” in an OUT or a TRG sends a CN frame.
0	1	0F	16 CN_frames after an OUT or a TRG frame. The Node whose upper 5 bits of MAC ID corresponds to the upper 5 bits of the “CN Request MAC ID” in an OUT or a TRG sends a CN frame.
1	1	0F	

5.2.2.7.4 Speed Code

Table 32 presents Speed Code definition.

Table 32 – Speed Code of BEACON frames

B0	B1	B2	Meaning
0	0	0	93,75 kbit/s
1	0	0	Reserved
0	1	0	1,5 Mbit/s
1	1	0	3 Mbit/s
0	0	1	4 Mbit/s
1	0	1	Reserved
0	1	1	Reserved
1	1	1	Reserved

5.2.2.7.5 Last repeater node address

This is the node address of the last repeater through which a BEACON frame passed. The master resets it to zero when it sends a BEACON. See 5.4.6.

When a slave or a repeater receives a BEACON, this value is copied to its register. The master can get the value by STR. See Figure 25.

5.2.2.7.6 Gate count

The value increments by 1 every time when a BEACON frame passes through a repeater. The master sets the initial value to zero when it sends a BEACON. See 5.4.6.

When a slave or a repeater receives a BEACON frame, this value is copied to its Gate count field in the STR frame. The master can get the value with an STR. See Figure 25.

A slave that receives a BEACON with a Gate Count value greater than 2 shall not transition to the Participated state. A repeater with a Gate Count value greater than 1 shall not repeat any frames.

5.2.3 Explicit messaging

5.2.3.1 General

All explicit message communication is performed in an unconnected manner using A_EVENT frames as shown in Figure 32. The master or slave or repeater nodes can send A_EVENT messages. The A_EVENT message format supports fragmentation for large requests and responses.

When slave or repeater nodes need to send an A_EVENT, they set the A_EVENT Sending Request bit in their CN frames. The master then grants the slaves or repeaters the right to transmit this request. This is done by issuing an A_EVENT Poll Request during a future EXTEND time domain. If the request is fragmented, the node is granted permission to send each subsequent fragment.

When the master issues an A_EVENT to a slave or repeater node that requires a response, it grants the slave or repeater node permission to respond by issuing an A_EVENT Poll Request.

When granting permission to a slave or repeater node, the master can issue the A_EVENT Poll Request at any time and rely on the response to determine if the device was ready. Alternatively the master can wait for the next CN Frame that has the A_EVENT Sending Request bit set before issuing the A_EVENT Poll Request.

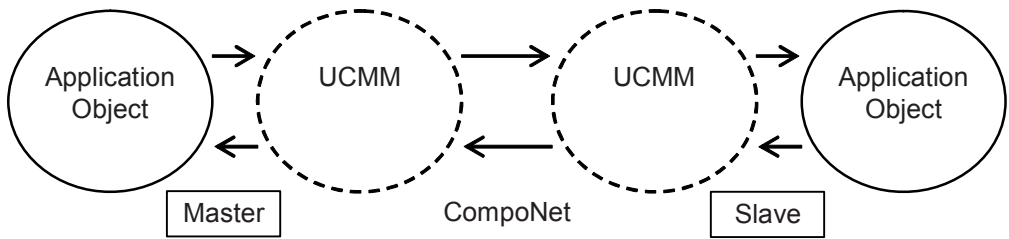

Figure 32 – Object diagram of A_Event message flow

5.2.3.2 Explicit messaging format

5.2.3.2.1 General

CompoNet encapsulates explicit messages into the event data part of A_EVENT frames as shown in Figure 32.

Explicit Message Service Data is first encoded as little endian, then each 16 bit word within this buffer is octet swapped and placed on the wire (high octet sent first, low octet last).

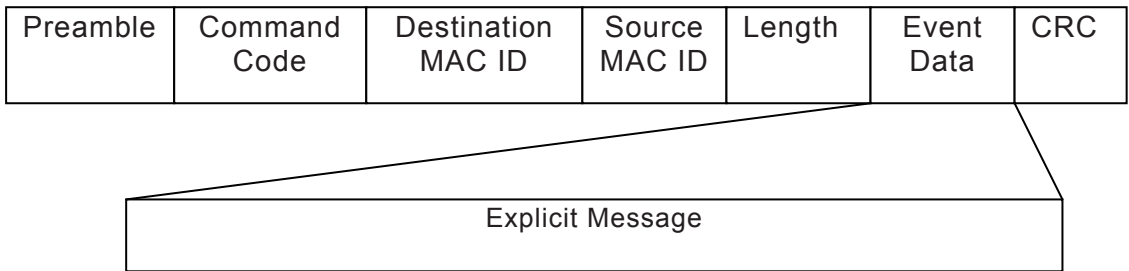

Figure 33 – A_EVENT message format

2 types of explicit message formats are defined:

- compact – 1 Octet Class ID and Instance ID (required), and
- expanded – CIP EPATH (optional).

All explicit message formats consist of a header and service data. The size of the message header and what data fields make up the header depends on whether it is a Compact or Expanded message type. The content of the service data is defined in Figure 40.

For an unfragmented explicit message request, or the first fragment of a fragmented explicit message request, the format shown in Figure 34 for Compact type or Figure 35 for expanded type is used. The first 7 words make up the message header. The format of “Padded EPATH” shown in Figure 35 refers to the service data format defined in Figure 40.

Word Offset	1 5	1 4	1 3	1 2	1 1	1 0	9	8	7	6	5	4	3	2	1	0
0	Control Code															
1	Destination MAC ID															
2	Source MAC ID															
3	Extended SID								SID							
4	Size															
5	Reserved								Service Code							
6	Class ID								Instance ID							
7–21	Service Data (0 octet - 30 octet)															

**Figure 34 – Compact message type request format
(non-fragmented frame/first fragment frame)**

Word Offset	1	1	1	1	1	1	9	8	7	6	5	4	3	2	1	0
0	Control Code															
1	Destination MAC ID															
2	Source MAC ID															
3	Extended SID								SID							
4	Size															
5	Reserved								Service Code							
6	Reserved								EPATH Length							
7-21	Padded EPATH															
	Service Data															

Figure 35 – Expanded message type request format (non-fragmented frame/first fragment frame)

For an unfragmented response, or the first fragment response of an explicit message, the format shown in Figure 36 is used. The format is used by a responder, which could be the master, a slave, or a repeater. The first 6 words make up the message header.

Word Offset	1	1	1	1	1	1	9	8	7	6	5	4	3	2	1	0
0	Control Code															
1	Destination MAC ID															
2	Source MAC ID															
3	Extended SID								SID							
4	Size															
5	Reserved								1	Service Code						
6 to 21	Service Data (0 octet to 32 octet)															

Figure 36 – Compact/Expanded message successful response format (unfragmented frame/first fragment frame)

For an unsuccessful response, the format shown in Figure 37 is used. The first 6 words make up the message header.

Word Offset	1 5	1 4	1 3	1 2	1 1	1 0	9	8	7	6	5	4	3	2	1	0
0	Control Code															
1	Destination MAC ID															
2	Source MAC ID															
3	Extended SID								SID							
4	Size															
5	Reserved								0x94							
6	General Status Code								Additional Status Code							

Figure 37 – Compact/Expanded message unsuccessful response format (unfragmented frame/first fragment frame)

For a fragmented message communication, after the first acknowledgement is received, the requester uses the format shown in Figure 38 for the 2nd through last fragments of the exchange. In a similar fashion, the responder uses the format shown in Figure 39 when transmitting a fragmented message communication, for the 2nd through last fragments of the exchange. Bit 9 in the Control Code field is used to determine if the frame is fragmented or unfragmented. The header is the first 2 words for both figures.

Word Offset	1 5	1 4	1 3	1 2	1 1	1 0	9	8	7	6	5	4	3	2	1	0
0	Control Code															
1	SID								Reserved							
2 to 21	Service Data (0 octet to 40 octet)															

Figure 38 – Compact/Expanded message request format for fragments

Word Offset	1 5	1 4	1 3	1 2	1 1	1 0	9	8	7	6	5	4	3	2	1	0
0	Control Code															
1	SID								Reserved							
2 to 21	Service Data (0 octet to 40 octet)															

Figure 39 – Compact/Expanded message response format for fragments

The Service Data is defined in Figure 40. If the service data consists of an odd number of octets, a pad octet with value 00 is added to the last octet position.

Word Offset	1	1	1	1	1	1	9	8	7	6	5	4	3	2	1	0
n	Octet 1st						Octet 2nd									
n+1	Octet 3rd						Octet 4th									
...	...						(Pad octet)									

Figure 40 – Service data format

5.2.3.2.2 Control code (2 octets)

Table 33 presents the Control code definition.

Table 33 – Control code format

Bit	Name	Description
15	Frame type	The bit is set to 0 for request and set to 1 for response.
14	Response request	The bit is always set to 1 in a request and 0 in a response.
13 to 12	Message Type ^a	00: Compact Explicit message type 01: Expanded Explicit message type 10:(reserved) 11:(reserved)
11 to 10	Reserved	The bits are always set to 0 and reserved for expansion.
9 to 8	Fragment Type	See Table 35.
7 to 0	Fragment Count	Fragment counter. For a single frame, the counter value is set to 0 in the head fragment.
^a In a response, the message type is always 0.		

5.2.3.2.3 Destination MAC ID

Destination MAC ID indicates the receiver of an A_EVENT message. If it is different from the value in the frame header, routing is required.

5.2.3.2.4 Source MAC ID

Source MAC ID indicates the sender of an A_EVENT message. If the A_EVENT message server generates a response, the value is designated in the source MAC ID of an A_EVENT message.

5.2.3.2.5 SID

Security Identifier or SID is used for matching transmission and reception. The client selects the value and the server echoes it back. The value selected is vendor specific.

- If the master is the client, the range of SID is 0x00 to 0x7F (0 to 127).
- If a slave is the client, the range of SID is 0x80 to 0xFF (128 to 255).

5.2.3.2.6 Extended SID

The client selects the value and the server echoes it back. The value selected is vendor specific.

5.2.3.2.7 Size

The octet size of service data is designated in the following range: 0x0 to 0xFFFF (0 to 65535).

- Non-fragmented frames: 0x00 to 0x1E (0 to 30) for a request frame of compact message type; 0x00 to 0x20 (0 to 32) for a response frame.
- Fragmented frames: 0x1F to 0xFFFF (31 to 65535) for a request frame of compact message type; 0x21 to 0xFFFF (33 to 65535) for a response frame.
- For EPATH message format, the size range depends on EPATH Length.

5.2.3.2.8 EPATH length

This is the size in 16-bit words of an EPATH that follows.

5.2.3.2.9 General and additional status codes

Unsuccessful responses shall contain a General Status Code indicating the reason for failure. Optionally an Additional Status Code may be included to provide more information.

CompoNet receivers acknowledge every fragmented message at the data link level. There is no way to inform the sender of an oversize error code immediately after receiving the first fragment. Only after all fragments are received can the receiver check the received message, and then return a response with status.

The receiver cannot fully process oversize messages. If the "Size" in the first fragment explicit message request is greater than the receiver's buffer size, the receiver shall return a status code of "the message is longer than the receiving buffer" (0x23).

For unsupported message types, the receiver shall return a compact message type response with a status code of "message format not supported" (0x24).

5.2.3.2.10 A Data encoding example

An example is given to illustrate data transfer.

Assumption: The master is requesting a Set_Attribute_Single of 4 octets of data, 0x1234(word)-and 0x5678(word) to Class 0x64, Instance 0x01, Attribute 0x65 of a slave whose MAC ID is 0xD0. The Control Code is 0x4000.

At the master's application, the EM request is listed as shown in Table 34.

Table 34 – A Data encoding example

Word Offset	1 5	1 4	1 3	1 2	1 1	1 0	9	8	7	6	5	4	3	2	1	0	Description
0	40						00						Control Code				
1	00						D0						Destination MAC ID				
2	01						C0						Source MAC ID				
3	Extended SID						SID						Extended SID		SID		
4	00						05						Size				
5	Reserved						10						Reserved		Service Code		
6	64						01						Class ID		Instance ID		
7	65						34						Attribute ID		Service Data		
8	12						78										
9	56						Pad(00)										

When the slave receives the request, it decodes the information in word 0 through word 6 using the header format information given above. It decodes the service data from word 7 on as CIP definitions. So the slave knows it is a Set_Attribute_Single service to Class 0x64, Instance 01, Attribute 0x65 with data 0x1234, 0x5678.

5.2.3.3 Fragmentation protocol

5.2.3.3.1 General

This subclause defines the means by which a message whose length is greater than 44 octets, which is the maximum size of A_EVENT frame, is fragmented and reassembled.

Important: Masters shall support the transmission and reception of messages in a fragmented manner. This capability is optional for slaves and repeaters, but mandatory for masters.

Explicit Message senders examine the length of each message to be transmitted. If the message is greater than 44 octets in length, then the fragmentation protocol is used.

The Fragmentation Protocol is located within a single word called Control Code in the A_EVENT Event Data Field. See Table 33.

5.2.3.3.2 Fragmentation protocol contents

Fragment type: This indicates whether the message is a single frame, which means the message is not fragmented, or one of the first, middle or last transmission for a fragmented message. The following values in Table 35 are defined:

Table 35 – Fragment type values

Value	Meaning
0	Single frame, The Fragment Count field shall contain the value 0. ^a
1	First fragment. The Fragment Count field shall contain the value 0. ^b
2	Middle fragment. ^c
3	Last fragment ^d
^a Indicates that this is a non-fragmented message. ^b Indicates that this is the first of sequential fragments. ^c Indicates that this is a midstream fragment. This fragment is neither the first nor the last fragment in series. It also indicates more fragments are to follow. ^d Marks it as the last fragment. This is used after having transmitted one or more fragments in ahead of.	

Fragment count: This marks each separate fragment so that the receiver can identify if any fragment is missed. The Fragment Count increments by one (1) for each successive fragment received. The counter goes back to zero (0) when it reaches the value 256 (fragmentCount = (fragmentCount + 1) mod 256).

If the Fragment type is not 0, it means the transmission is only a portion of the Explicit Message, not the entire message.

Message fragmentation is performed as a data-link level acknowledgement. The receiver returns only data-link level acknowledgments for every fragment.

The **transmitting** side functions as specified below:

- The sender formulates the message header by setting the Control Code, the Extended SID and SID fields to the value specified by the Application. It initializes the MAC ID fields and other fields. See 5.2.3.2.
- The sender then places the appropriate Fragmentation Protocol information into the message. The sender stores the Fragment Count that is inserted into the message. The first fragment and middle fragments shall be a full-sized A_EVENT. Otherwise a non-fragmented message or the last fragment shall be used.
- The sender then takes the next piece of the Service Data and places it into the message.
- If the sender is a slave or repeater, it sets the bit “A_EVENT sending request” in its CN frames to inform the master that it needs to send a message. It starts its Explicit Message Timer if this is the first transmission of the message.
- The sender transmits the message and waits for a positive data-link level acknowledgement.
- If no positive acknowledgement is received, the sender retries the last transmission. The retry mechanism is defined in 5.2.4. If the retries fail, then the Application is informed that an error has been detected and the requested transmission cannot take place.

If a positive acknowledgment is received, then the sender continues normal processing. If the sender is a slave or repeater, the reception of a positive acknowledgement clears “A_EVENT sending request” bit in its CN frames.

The *initial state* associated with the receiving side entails waiting for either the First Fragment in a fragmented transmission or waiting for the reception of a complete Explicit Message.

The **receiving** side functions as specified below:

- a) If the message header indicates that this is a fragmented Explicit Message, then the receiver examines the Fragmentation Protocol to determine its validity. If the receiver has

yet to receive the first transmission in the series (in the *initial state*) and the Fragment field is not equal to *First Fragment*, then the fragment is dropped.

- b) If it is a single frame message and the Fragment Count is 0, the receiver does the following:
- processes the message, and
 - resets to the initial state.
- c) If the Fragment indicates that this is the *First Fragment*, then the Fragment Count shall equal zero (0) and it is full-sized. If this is the case, then the message fragment is stored. If the Fragment indicates *First Fragment* and the Fragment Count is not zero (0), then the fragment is dropped.
- d) If the Fragment Count is one (1) greater than the previously received count and the Fragment indicates that this is the Middle Fragment or Last Fragment, the SID is the same as previously received SID and it is a full-sized fragment, then the next fragment has been received. The fragment is appended to the previously received fragment(s). The Fragment Count associated with this fragment is stored.
- e) If the Fragment Count is same as the previously received count, the SID is same as previously received SID, and the Fragment does not indicate that this is the First Fragment, then a resent fragment has been received. No action is needed.
- f) If the Fragment Count is neither one (1) greater nor equal to the previously received count, then the fragment is discarded. The receiver resets to the *initial state*.
- g) When the last fragment is received the receiver continues processing the message.

The Event/Action Matrices presented in Table 36 and Table 37 provide formal definitions of the transmitting and receiving sides of the Fragmentation Protocol.

Table 36 – Fragmented transmission

Event	Condition	Action
Sending First Fragment.	The message can not be sent in a non-fragmented Explicit Message. The "Length" of A_EVENT data shall be 22 words.	Fragment Count = 0. Fragment Type = First Fragment. Build and transmit the full-sized message. Wait for the positive acknowledgment to be returned.
Time-out while waiting for a positive acknowledgment occurs (This applies only for the master sender. The timer value is defined in 5.6.3.5)	Retries are needed. See 5.2.4.	Re-transmit the previously sent message fragment. Wait for a positive acknowledge to be returned.
	All retries fail. See 5.2.4.	Discontinue the attempt to transmit this message. Issue the necessary internal indications.
The Explicit Message Timer expires (This applies only for a slave or repeater sender, See 5.2.4)	None	Discontinue the attempt to transmit this message. Issue the necessary internal indications.
Receive a positive acknowledge associated with either the First Fragment or a Middle Fragment	None	Build and transmit the next fragment per the Event column. A slave or repeater sender needs to clear the bit "A_EVENT sending request" in its CN frames, then set the bit again if it is ready to transmit the next fragment.

Event	Condition	Action
Receive a positive acknowledge associated with the Last Fragment	None	Indicate that the message has been successfully delivered to the remote destination. Start the Explicit Message Timer if the sender is the master. Clear the bit "A_EVENT sending request" in CN frames if the sender is a slave or repeater.
Sending "midstream" fragment (not the first nor the last).	The remainder of the message can not be sent in ONE fragment. The "Length" of A_EVENT data shall be 22 words.	Increment previously transmitted Fragment Count by one (1). Fragment = Middle Fragment. Use the same SID as previous one. Build and transmit the full-sized message fragment. Wait for a positive acknowledgment to be returned.
Sending last fragment	The remainder of the message can be sent in ONE fragment. The length of "Service Data" can not be zero (0).	Increment Fragment Count by one (1). Fragment = Last Fragment. Use the same SID as the previous one. Build and transmit the message fragment. Wait for a positive acknowledgment to be returned.
The last fragment of an Explicit Request Message has been sent.	The associated response message is received prior to receiving the Acknowledgment associated with the Last Fragment	Discard the received response message.

The initial state referenced in Table 37 below is defined as the state waiting for either the First Fragment in a fragmented transmission or for the reception of a complete Explicit Message, i.e. a non-fragmented message.

Table 37 – Fragmented reception

Event	Condition	Action
Receive First Fragment	The receiver can not process the fragmented message because of oversize or unknown message type. See 5.2.3.2.10.	An error has been detected. Waiting for the last fragment.
	Fragment Count IS NOT equal to zero (0).	Discard the fragment and reset to the <i>initial state</i> .
	Fragment Count=0, NOT full-sized message	Discard the fragment and reset to the <i>initial state</i> .
	Fragment Count = 0, and it is a full-sized message	Store the Fragmentation Protocol word and associated message fragments. Store the Extended SID and SID. If the receiver is still in the process of receiving the previous fragmented message that has yet to be completed, then the previous message is discarded and the receiver begins processing this new fragmented message.
Received Fragment = Middle Fragment.	The First Fragment <u>HAS NOT</u> yet been received.	Discard the message fragment.

Event	Condition	Action
	The Fragment Count is numerically one (1) greater than the previously received Fragment Count. The SID is same as the previously received one and the message is full-sized.	Store the Fragment Count and associated message fragment.
	The Fragmentation Protocol word Control Code is equal to the previously received Fragmentation Protocol word Control Code, the SID is same as the previously received one and the message is full-sized.	Discard the message fragment.
	NOT full-sized message	Discard the fragment and reset to the <i>initial state</i>
	The SID is different from the previously received one.	Discard the fragment and reset to the <i>initial state</i>
	The Fragment Count is neither one (1) greater than nor equal to the previously received Fragment Count.	Discard the fragment and reset to the <i>initial state</i>
	Too much data has been received.	Discard the fragment and reset to the <i>initial state</i> .
Received Fragment Type = Last Fragment.	The First Fragment <u>HAS NOT</u> yet been received.	Discard the message fragment.
	An error has been detected while receiving the first fragment.	Return a response with the General Status set to indicate the error that has occurred if the receiver is Server. Inform to the Application if the receiver is Client. Reset to the <i>initial state</i>
	The Fragment Count is numerically one (1) greater than the previously received Fragment Count. The SID is same as the previously received one. The size of Service Data is NOT zero (0).	Process the received Explicit Message.
	The Fragmentation Protocol word Control Code is equal to the previously received Fragmentation Protocol word Control Code and the SID is same as the previously received one. The size of Service Data is NOT zero (0).	Discard the message fragment.
	The size of Service Data is zero (0).	Discard the fragment and reset to the <i>initial state</i>
	The SID is different from the previously received one.	Discard the fragment and reset to the <i>initial state</i>
	The Fragment Count is neither one (1) greater than nor equals to the previously received Fragment Count.	Discard the fragment and reset to the <i>initial state</i> .
	Data of wrong size has been received. The real data size does not match the declared size in the first fragment.	Discard the fragment and reset to the <i>initial state</i> .
Receive non-fragmented message	In the process of <u>receiving</u> a fragmented message	Discontinue processing associated with the fragmented message. Process the received non-fragmented message. Reset to the <i>initial state</i> .

5.2.4 Explicit messaging client/server timing requirement

5.2.4.1 General

This subclause specifies explicit messaging timing requirements for devices. Two different timeout conditions can occur and are described in the following subclauses.

5.2.4.2 Link layer acknowledgement timeout

CompoNet uses data-link level acknowledgement to improve communication efficiency. Once it receives an A_EVENT frame, the receiver shall reply immediately with a positive or a negative acknowledgement.

If the master is the requester and fails to receive a data link response from the receiver after 10 attempts, the master stops waiting and can schedule a retry later. If the master received a negative acknowledgement, it resends the request until it receives a positive acknowledgment, or until 2 s have passed.

If a slave or repeater is the requester, there is no timeout period for data-link level acknowledgement. Slave and repeater devices rely on the Explicit Message Timeout event to identify an unsuccessful explicit message transaction.

5.2.4.3 Explicit message timeout

An explicit message timer is used to detect an unsuccessful explicit message transaction. This timer is maintained by both client and server endpoints. The timer behaviour differs among clients, servers, master, and slave or repeater devices. The value loaded into the timer is based on the Device Category and the data rate as shown in Table 38.

Table 38 – Explicit message timeout values

Device category	Transmission speed	Default s
Master		2
Slave or repeater	4 Mbit/s	3
	3 Mbit/s	4
	1,5 Mbit/s	8
	93,75 kbit/s	115

- Master timer behaviour

As a client, the master shall run an explicit message timer while it waits for a response from a slave or repeater. The timer is started when the master is notified that the last request frame has been sent. If the timer expires before the last response frame is received from the slave or repeater, the transaction is considered timed out. The application is then notified of the timeout event.

As a server, the master does not run an explicit message timer.

- Slave or repeater timer behaviour

As a client, the slave or repeater shall run a separate explicit message timer during both the request and response phases of the explicit message transaction.

During the request phase, the slave or repeater starts the timer when the application is ready to start transmitting the request, as indicated by setting the “A_EVENT Sending Request” flag in the CN response frame. The timer is cleared when the application is notified that the last request frame has been sent. If the timer expires before the last request frame is sent, the device shall reset or clear the “A_EVENT Sending Request” flag in the CN response frame and notify the application of the timeout event.

During the response phase, the slave or repeater starts the timer when the application is notified that the last request frame has been sent. If the timer expires before the last response frame is received from the master, the application is notified of the timeout event.

As a server, the slave or repeater shall run an explicit message timer while it sends a response to the master. The timer is started when the application is ready to start transmitting the response, as indicated by setting the “A_EVENT Sending Request”

flag in the CN response frame. If the timer expires before the last response frame is sent, the slave or repeater shall reset or clear the “A_EVENT Sending Request” flag in the CN response frame and may notify the application of it

5.3 CompoNet communication object classes

5.3.1 General

Communication in a node is modelled as a collection of objects: CompoNet communication objects manage and provide the exchange of messages.

An object provides an abstract representation of a data structure within a node. An object class is a set of objects that all represent the same type of object. An object instance is the actual representation of a particular object within a class. Each instance of a class has the same set of attributes, but has its own particular set of attribute values.

An object instance and/or an object class have attributes, provide services and implements behaviour.

Attributes are characteristics of an object and/or an object class. Attributes provide status information or govern the operation of an object. Services are invoked to trigger the object class or instance to perform a task. The behaviour of an object indicates how it responds to particular events.

The main communication objects used are listed in the following subclauses (see 5.3.2.to 5.3.6). See Annex D for a description of data type specification and encoding, and Annex E for the definition of auxiliary communication objects.

5.3.2 Identity object class definition (class ID code: 01_{Hex})

The identity object identifies and provides general information about the node. The identity object is fully specified in IEC 61158-5-2, 6.2.1.2.2 and IEC 61158-6-2, 4.1.8.2.

CompoNet devices shall not support the Heartbeat Interval attribute.

5.3.3 Message router object class definition (class ID code: 02_{Hex})

The message router object provides a messaging connection point through which a client may address a service to any object class or instance residing in the node. The message router object is fully specified in IEC 61158-5-2, 6.2.1.2.4 and IEC 61158-6-2, 4.1.8.3.

5.3.4 Connection object class definition (class ID code: 05_{Hex})

5.3.4.1 General

The connection class allocates and manages the internal resources associated with I/O connection. The specific instance generated by the connection class is referred to as a connection instance or a connection object.

The connection class is fully specified in IEC 61158-5-2 and IEC 61158-6-2. This includes:

- attributes and services for the connection object class and instances (see IEC 61158-5-2, 6.2.3 and IEC 61158-6-2, 4.1.8.8);
- connection timing (see IEC 61158-5-2, 6.2.3);
- connection instance behaviour (see IEC 61158-6-2, 7.2).

CompoNet uses a predefined connection-based communication for I/O data exchange. No connection-based explicit connection is defined at this time. This subclause describes the specific parts of communication model.

5.3.4.2 Instance attributes

5.3.4.2.1 Instance type, attribute 2

The only value supported is 1, I/O Connection type.

5.3.4.2.2 Expected packet rate, attribute 9

This value is selected to obtain the desired connection timeout. The I/O watchdog timer in the I/O connection class is limited to a maximum of 650 ms for transmission speed of 93,75 kbit/s and to 200 ms for other speeds. Thus, using the connection timeout multiplier of 4, this attribute has a maximum value (based on data rate) as shown in Table 39.

Table 39 – Maximum value of expected packet rate

Data rate	Maximum value
93,75 kbit/s	162 ms
Others	50 ms

CompoNet does not use a pre-consumption timer.

5.3.4.2.3 CIP produced connection ID, attribute 10

CompoNet devices shall not support the Produced Connection ID attribute.

5.3.4.2.4 CIP consumed connection ID, attribute 11

CompoNet devices shall not support the Consumed Connection ID attribute.

5.3.4.2.5 Production inhibit time, attribute 17

CompoNet devices shall not support the Production Inhibit Time attribute.

5.3.4.2.6 Connection timeout multiplier attribute 18

CompoNet devices shall not support the Connection timeout multiplier attribute. The multiplier value is fixed to 4.

5.3.4.2.7 Connection binding list attribute 19

CompoNet devices shall not support the Connection binding list attribute.

5.3.4.3 Connection object attribute access rules

CompoNet connection object attribute access rules are specified in Table 40.

Table 40 – CompoNet connection object attribute access rules

Attribute	I/O connection state		
	Configuring ^a	Established	Timed out
state	Get	Get	Get
instance type	Get	Get	Get
transportClass trigger	Get/Set	Get	Get
produced connection size	Get/Set	Get	Get
consumed connection size	Get/Set	Get	Get
expected packet rate	Get/Set	Get/Set	Get/Set

Attribute	I/O connection state		
	Configuring ^a	Established	Timed out
watchdog timeout action	Get/Set	Get/Set	Get/Set
produced connection path length	Get	Get	Get
produced connection path	Get/Set	Get	Get
consumed connection path length	Get	Get	Get
consumed connection path	Get/Set	Get	Get
^a The I/O connection is only in this state during process of the CompoNet Link Object Allocate service. The settable values are loaded from parameters of that service.			

5.3.4.4 Connection object services

5.3.4.4.1 General

CompoNet connection object services are defined in this subclause.

5.3.4.4.2 Connection object class services

CompoNet devices do not support the Create or Delete services.

5.3.4.4.3 Connection object instance services

CompoNet devices do not support the Delete service.

5.3.4.4.4 Creating connections through the CompoNet Link object

5.3.4.4.4.1 General

I/O Connections are created via the CompoNet Link object using the Allocate Service (Service code 4B_{Hex}) to instantiate the desired connections.

5.3.4.4.4.2 Allocate behaviour (Service code 4B_{Hex})

This is the service utilized to perform the allocation of the Predefined Master/Slave Connection Set for a slave or repeater. Status codes listed below in *italics* are defined in Annex B. CompoNet Link Object defined by Additional Code values are presented in 5.3.4.4.4.4.

The allocate service bundles the following general steps into one command:

- Connection Object Create, and
- Connection Object Configuration.

If the receiving device (i.e. a slave or a repeater) does not support the Predefined Master/Slave Connection Set, then an Error Response is returned. The General Error Code within the Error Response is set to 0x08 to indicate *service not supported*.

The device validates the Allocation Choice parameter within the request. If the device does not support one of the Connections specified in the Allocation Choice argument (including Reserved bits), then an Error Response is returned. The General Error Code within the Error Response is set to 0x02, which indicates Resource Unavailable, with the Additional Code set to an Object Specific value of 0x02.

If the Allocation Choice octet has no bits set, which means that all bits are zero, the device returns an Error Response. In the response, the General Error Code is set to 0x09, which

indicates Invalid attribute data detected, and the Additional Code is set to an Object Specific value of 0x02.

For a repeater, the allocate service is only used to change the EPR and the explicit message timer. The allocate choice shall be 0x02 for a repeater.

If a slave or repeater in the EventOnly substate is allocated, the slave or repeater returns an Error Response with the General Error Code set to 0x10, which indicates Device state conflict.

If any of the Connection(s) being requested are supported by this slave or repeater and have already been allocated to the master, the slave or repeater returns an Error Response with the General Error Code set to 0x0B (Already In Requested Mode/State), with the Additional Code set to an Object Specific value of 0x02. The master has the option to send a Release request as it may be out-of-sync with the slave or repeater. The exception to this is when the requested I/O connection is in the Timed-Out state. In this case the slave or repeater reallocates the I/O connection, sending it back to the Configuring State.

If a resource that is required for use with the requested Connections is not available, then an Error Response is returned with the General Error Code set to 0x02 (Resource Unavailable), and the Additional Code set to an Object Specific value of 0x04.

Important: If an error is encountered, then none of the requested connections shall be allocated. If this request cannot be fully serviced, then none of the requested allocations shall be done.

The Allocation Choice attribute indicates which Connection Objects from the Predefined Master/Slave Connection Set are active. This octet may need to be updated whenever a Master/Slave Connection Object changes state.

If the value in the Connection time-out period field is out of range, then an Error Response is returned with the General Error Code set to 0x20, indicating *Invalid Parameter*.

Once the Allocation Choice parameter is validated, any allocated I/O Connection(s) transition to the Configuring state. The default connection values as specified in 5.3.5.5.3.2 are loaded into the connection attributes. The EPR attribute is configured with the value from the Connection time-out period parameter. The I/O Connection then makes a transition to the Established state.

The Inactivity/Watchdog Timer functions as described in IEC 61158-5-2, 6.2.3.

5.3.4.4.4.3 Release behaviour (Service code 4C_{Hex})

The receiving device, i.e. slave or repeater, validates the Release Choice parameter within the request. If the slave or repeater does not support one of the Connections specified in the Release Choice argument (including Reserved bits), then an Error Response is returned. The General Error Code within the Error Response is set to 02, which indicates Resource Unavailable, with the Additional Code set to an Object Specific value of 02.

If the Release Choice octet has no bits set, which indicates all bits are zero, the slave or repeater returns an Error Response with the General Error Code set to 09 (Invalid Attribute Value), with the Additional Code set to an Object Specific value of 02.

Important: If an error is encountered, then none of the specified connections shall be released. If this request cannot be fully serviced, then none of the requested releases shall be done.

If one of the specified Connections is in the non-existent state, then an Error Response is returned. The General Error Code within the Error Response is set to 0B_{hex} to indicate *Already In Requested Mode/State*.

Once the Release Choice parameter has been validated, the slave or repeater ensures that it is in a state that allows it to discontinue use of the specified Connection(s). If this is not the case, then an Error Response is returned. The General Error Code within the Error Response is set to 0C_{hex} to indicate *Cannot Perform Service In Current Mode/State*.

If the request is valid, then the slave or repeater releases all resources associated with the specified Connection(s).

5.3.4.4.4 Error codes specific to the CompoNet Link object

The following table lists error codes specific to the CompoNet Link Object. These codes are placed in the Additional Code field within an Error Response message. These codes as specified in Table 41 are referenced and described in detail throughout the preceding subclauses.

Table 41 – CompoNet Link object specific additional error codes

Value	Meaning
02	Invalid Allocation/Release Choice parameter. This is returned when an Allocate/Release_Master/Slave_Connection_Set request is received and: <ol style="list-style-type: none"> 1) the slave or repeater does not support the choice specified in the Choice parameter. 2) the slave or repeater is asked to Allocate/Release connection(s) which has already been allocated/released. 3) the Allocation Choice/Release octet contained all zeros or an invalid combination of bits.
04	Resource required for use with the Predefined Master/Slave Connection Set is not available.

5.3.4.5 Slave connection object characteristics

5.3.4.5.1 General

This subclause presents the externally visible characteristics of the Connection Objects associated with the Predefined Master/Slave Connection Set within slave or repeater devices. The Predefined Master/Slave Connection Object defined for the slave or repeater devices is the Multicast Poll Connection, which is responsible for receiving the master's Multicast Poll Command and returning the associated Response.

Important: This subclause further refines information presented in IEC 61158-5-2, 6.2.3 for use by Connection Objects. Except where noted, all information specified in IEC 61158-5-2, 6.2.3. (e.g. Services, Attributes, etc.) applies to the Connection Objects described in this subclause.

5.3.4.5.2 Connection instance IDs

Every Connection Object in existence has an assigned Connection Instance ID, which identifies the Connection Object amongst several Connection Objects within the Connection Class. The Instance IDs that shall be utilized by a slave or repeater device to identify Predefined Master/Slave Connection Objects are shown in Table 42.

Table 42 – Connection instance ID for predefined master/slave connections

Connection Instance ID N°	Description
1	References the Multicast Poll I/O Connection

Important: A slave or repeater shall reserve the Instance IDs from Table 42 for the Predefined Master/Slave Connections that it supports.

5.3.4.5.3 Slave connection instance attributes

This subclause defines default attribute values utilized by a slave or repeater device within Predefined Master/Slave Connection Objects.

Table 43 defines attribute values for the Predefined Master/Slave I/O Connection Objects. These default values are initially loaded into the attributes when the Connection Object makes a transition from the Non-existent state to the Configuring state (see 5.3.4.5.4). Attributes not supported are not listed.

Table 43 – Default multicast poll connection object attribute values

Attribute ID (decimal)	Attribute name	Default value	Description
1	state	01	Indicates the Multicast Poll Connection Object is in the Configuring state.
2	Instance_type	01	Indicates this is an I/O Connection.
3	transportClass_trigger		0x82 for IN and Mix slaves 0x80 for OUT slaves and repeaters
7	produced_connection_size		No default specified. An implementation shall initialize this attribute according to the application.
8	consumed_connection_size		No default specified. An implementation shall initialize this attribute according to the application.
9	expected_packet_rate	0	Expected packet rate shall be configured.
12	watchdog_timeout_action	0	Transition to the Timed Out state.
13	produced_connection_path_length		No default specified. An implementation shall initialize this attribute with the number of octets in the default produced_connection_path attribute.
14	produced_connection_path		No default specified. An implementation chooses an Application Object to reference by default and initializes this attribute accordingly.
15	consumed_connection_path_length		No default specified. An implementation shall initialize this attribute with the number of octets in the default consumed_connection_path attribute.
16	consumed_connection_path		No default specified. An implementation chooses an Application Object to reference by default and initializes this attribute accordingly.

5.3.4.5.4 Predefined master/slave connection instance behaviour

Figure 41 illustrates the Predefined Master/Slave Connection Set I/O Connection Object State Transition Diagram.

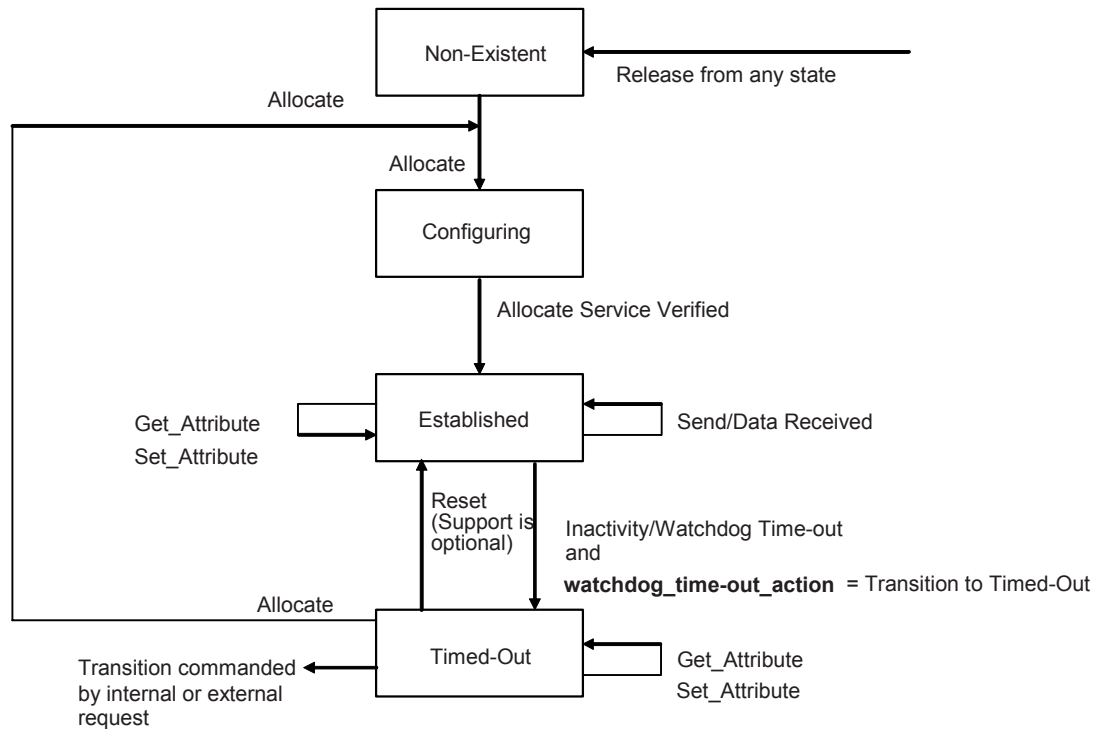

Figure 41 – Predefined master/slave I/O connection state transition diagram

The State Event Matrix, or SEM, presented below provides a formal definition of the behaviour of I/O Connections within the Predefined Master/Slave Connection Set. The SEM inherits from and/or overrides actions presented in the I/O Connection Object State Event Matrix in IEC61158-6-2, 7.2.1.

Important: The SEM presented below does not dictate rules with regards to product specific, internal logic. Any attempt to access the Connection Class or a Connection Object instance may need to pass through product specific verification. This may result in an error scenario that is not indicated in Table 44. This may also result in additional, product specific indications delivered from a Connection Object to the application and/or a specific Application Object. The specific requirement is that the Predefined Master/Slave I/O Connection Object shall exhibit the externally visible behaviour specified by the SEM and the attribute definitions.

Table 44 – Predefined master/slave I/O connection state event matrix

Event	I/O connection object state			
	Non-existent	Configuring	Established	Timed out
CompoNet Link Object receives an <i>Allocate</i> Request that passes all error checks. This request specifies the Predefined Master/Slave I/O Connection.	Instantiate a Connection Object for each requested I/O Connection & set attributes to default values specified in 5.3.4.5.3. Transition to Configuring.	This is an error scenario described in 5.3.4.4.4.	This is an error scenario described in 5.3.4.4.4.	Set attributes to default values specified in 5.3.4.5.3. Transition to Configuring.
CompoNet Link Object receives a Release Request that passes all error checks. This request specifies the Predefined Master/Slave I/O Connection.	This is an error scenario described in 5.3.4.4.4.	N/A	Release all associated resources. Transition to Non-existent.	Release all associated resources. Transition to Non-existent.

Event	I/O connection object state			
	Non-existent	Configuring	Established	Timed out
CompoNet Link Object Allocate Service parameters loaded into Connection Instance.	N/A	Transition to Established	N/A	N/A
Set_Attribute_Single	As described in IEC 61158-6-2, 7.2.1	Validate/service the request based on internal logic and per the Access Rules presented in 5.3.4.3. If this is a valid request to set the expected_packet_rate attribute, then perform the steps specified in IEC 61158-6-2, 7.2.1 and transition to Established. Return appropriate response.	Validate/service the request based on internal logic and per the Access Rules presented in 5.3.4.3. Return appropriate response.	Validate/service the request based on internal logic and per the Access Rules presented in 5.3.4.3. Return appropriate response.
Get_Attribute_Single	As described in IEC 61158-6-2, 7.2.1	Validate/service the request based on internal logic and per the Access Rules presented in 5.3.4.3. Return appropriate response.	Validate/service the request based on internal logic and per the Access Rules presented in 5.3.4.3. Return appropriate response.	Validate/service the request based on internal logic and per the Access Rules presented in 5.3.4.3. Return appropriate response
Reset	As described in IEC 61158-6-2, 7.2.1.	As described in IEC 61158-6-2, 7.2.1	As described in IEC 61158-6-2, 7.2.1	As described in IEC 61158-6-2, 7.2.1.
Receive_Data				
Send_Message				
Inactivity/Watchdog Timer expires				

If an implementation detects that it does not support an Explicit Messaging Service indicated in Table 44, then an Error Response specifying Service Not Supported (General Error Code 08) is returned.

5.3.4.6 Slave or repeater device state transition characteristics

5.3.4.6.1 Connection instance behaviour

After a successful STW, an IN slave goes to the ONLINE sub-state (Participated), and reacts to OUT/TRG frames, sending IN frames with valid input data even before it is allocated. When the master receives the input data, it does NOT transfer the data to its application until the master allocates the slave successfully. A slave shall NOT refresh its outputs before it is allocated.

For a repeater, a successful STW_Run Online or STW_Run EventOnly makes the Repeater transition to Participated and start repeating. A successful allocate service makes the Repeater in the ONLINE sub-state transition to the Established connection state.

After a slave or repeater goes to the Established state, it monitors OUT/TRG frames. If there is no OUT/TRG frames for a period of $EPR \times 4$, the connection transitions to the Timed out state.

There are 2 events that cause an output slave to transition to IDLE. An OUT frame with a disabled I/O refresh bit, or a TRG frame, is interpreted as a receive_idle event by an Application Object. An OUT frame with an enabled I/O refresh bit is interpreted as a run event by an Application Object.

5.3.4.6.2 Connection procedure

Figure 42 shows the connection procedure:

- Step A: The master sends a TRG-Frame to non-participated slave or repeater devices and recognizes offline devices. The offline devices send CN frames back to the master.
- Step B: The master sends STR requests to the slave or repeater devices that have sent CN frames. The slave or repeater devices send STR responses with their own vendor ID and serial number attached after received STR requests. The STR request and STR response are sent by using B_EVENT messages.
- Step C: The master adds the received vendor ID and serial number to a STW request and sends it to the appropriate device. If there is any device whose received vendor ID and serial number do not match its own vendor ID and serial number, the device makes a transition to the Communication Fault state. The STW request and STW response are sent by using B_EVENT messages.
- Step D: The master sends allocate requests to the slave or repeater devices Online. The Allocate request and allocate response are sent by using A_EVENT messages.

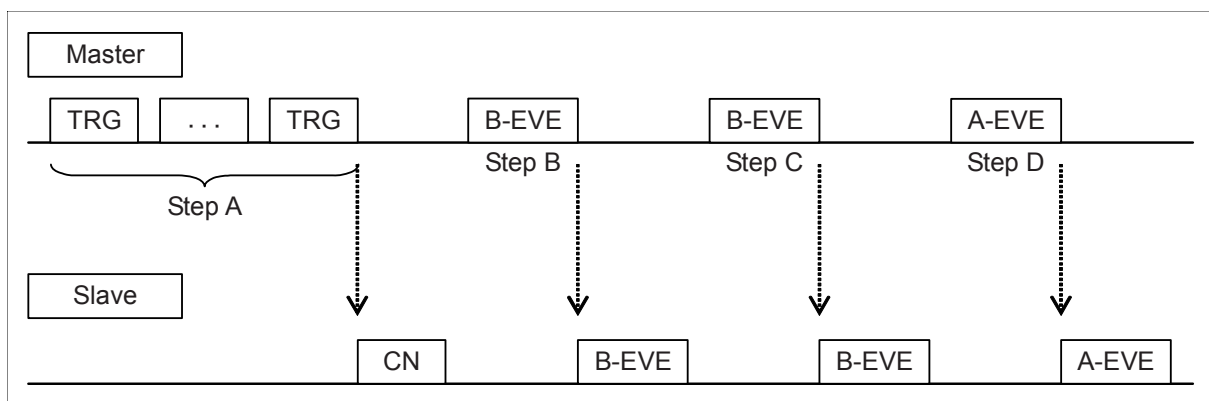

Figure 42 – Predefined master/slave I/O connection state transition diagram

5.3.4.6.3 Participation procedure flow

Figure 43 shows the connection flow.

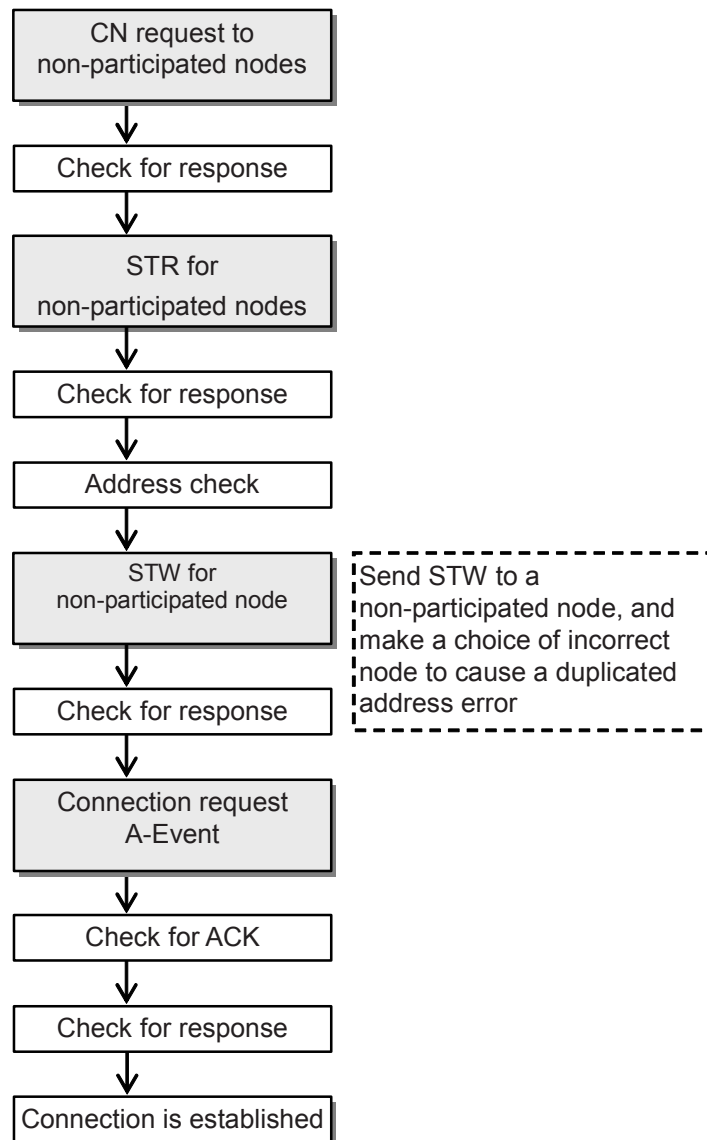

Figure 43 – Connection flow

5.3.4.7 Master communication characteristics

This specification does not present a large number of characteristics with respect to Connection Objects within a master. It is a requirement that the master understands how it has been configured with its associated slaves or repeaters and exhibits the external behaviour necessary to properly interface with those slaves or repeaters.

When it is reset or powered on, a master shall wait at least until all nodes go to their initial state (i.e. Speed Detection state). The waiting time differs by transmission speeds and is obtained by the following formula.

$$t = v \times 2$$

where

t is the waiting time, expressed in milliseconds (ms).

v is a multiplier set by the transmission speed. For a speed of 93,75 kbit/s, the multiplier is 650. For other speeds, it is 200.

For example, at 93,75 kbit/s the master waits for 650 ms (no OUT/TRG) until all participating nodes time out and go to the non-participating state. The master then waits for another 650 ms (no frames) to allow the non-participating nodes to go to the Speed Detection state. So a total of 1 300 ms of waiting time assures that all nodes are reset to the Speed Detection state.

NOTE Nodes in the Communication Fault state do not process new Control Codes and this can cause collisions when the Control Code in a BEACON frame is changed.

The master shall monitor its connections for timeouts. For IN or MIX nodes, monitoring shall be accomplished preferably via the detection of missing IN frames, or optionally via the detection of missing CN frames. For OUT nodes or repeaters, monitoring shall be accomplished via the detection of missing CN frames.

5.3.5 CompoNet Link object class definition (class ID code: F7_{Hex})

5.3.5.1 General

The CompoNet Link object is used to provide the configuration and status of a physical attachment. A product shall support one (and only one) CompoNet Link object per physical network attachment and it shall be instance 1.

5.3.5.2 CompoNet Link object class attributes

The class attributes for the CompoNet Link object are defined below in Table 45.

Table 45 – CompoNet Link class attributes

Attribute ID	Need In Implementation	Access Rule	Name	Data Type
1 through 7	These class attributes are optional and are described in IEC61158-5-2, 6.2.1.2.			

5.3.5.3 CompoNet link object class services

The CompoNet Link Object supports the following class services in Table 46.

Table 46 – CompoNet Link class services

Service Code	Need In Implementation	Service Name	Description
0x0E	Conditional ^a	Get_Attribute_Single	Used to read a CompoNet Link Object attribute.
^a Required if any class attributes are supported.			

5.3.5.4 CompoNet Link object instance attributes

5.3.5.4.1 General

The instance attributes of the CompoNet Link Object are defined as in Table 47.

Table 47 – CompoNet Link instance attributes

Attribute ID	Need in implementation	Access rule	N V	Name	Data type	Description	Semantics of values
1	Required	Get	N V	MAC ID	UINT	the MAC ID of this device.	See 5.3.5.4.2
2	Required	Get	V	Data Rate	USINT		See 5.3.5.4.3
3	--	--		Reserved			
4	--	--		Reserved			
5	Conditional ^c	Get	V	Allocation choice	OCTET		See 5.3.5.4.4

Attribute ID	Need in implementation	Access rule	N V	Name	Data type	Description	Semantics of values
6	Conditional ^a	Get	V	Node Address Switch Changed	BOOL		See 5.3.5.4.5
7	Conditional ^b	Get	V	Data Rate Switch Changed	BOOL		See 5.3.5.4.6
8	Conditional ^a	Get	V	Node Address Switch Value	UINT		See 5.3.5.4.7
9	Conditional ^b	Get	V	Data Rate Switch Value	USINT		See 5.3.5.4.8
10	Required	Set	V	Explicit message timer	UINT		See 5.3.5.4.9
11	Conditional ^b	Get	V	Active Node Table	ARRAY of 512 bits	Indicates node state. One bit for each MAC ID	1 = node in Participated state. 0 = node not in Participated state.
12	Conditional ^b	Get	V	WORD IN Node State Table	ARRAY of 64 octets	WORD IN node state. One octet per node address	See 5.3.5.4.11
13	Conditional ^b	Get	V	WORD OUT Node State Table	ARRAY of 64 octets	WORD OUT node state. One octet per node address	See 5.3.5.4.11
14	Conditional ^b	Get	V	BIT IN Node State Table	ARRAY of 128 octets	BIT IN node state. One octet per node address	See 5.3.5.4.11
15	Conditional ^b	Get	V	BIT OUT Node State Table	ARRAY of 128 octets	BIT OUT node state. One octet per node address	See 5.3.5.4.11
16	Conditional ^b	Get	V	Repeater Node State Table	ARRAY of 64 octets	Repeater node state. One octet per node address	See 5.3.5.4.11
^a This attribute is required when the device has a node address switch and it can be set to a value other than the online value. ^b This attribute is required for masters, but not allowed for other devices. ^c This attribute is required for slaves, but not allowed for masters.							

5.3.5.4.2 MAC ID

This attribute indicates the MAC ID of the device. The value ranges from 0 to 511. Table 48 shows the allocation of MAC IDs for each Device Category.

Table 48 – MAC ID range

Value	Device category
0x0000 – 0x003F (0 to 63)	Word slave (IN or MIX)
0x0040 – 0x007F (64 to 127)	Word slave (OUT)
0x0080 – 0x00FF (128 to 255)	Bit slave (IN or MIX)
0x0100 – 0x017F (256 to 383)	Bit slave (OUT)
0x0180 – 0x01BF (384 to 447)	Repeater
0x01C0 (448)	Master
0x01C1 – 0x01FF (449 to 511)	Reserved

If the MAC ID is set to an invalid value for the device type, the device makes a transition to the Communications Fault state.

5.3.5.4.3 Data rate

This attribute indicates the selected data rate. The possible attribute values are shown in Table 49.

Table 49 – Data rate

Value	Description
0	93,75 kbit/s
1	Reserved
2	1,5 Mbit/s
3	3 Mbit/s
4	4 Mbit/s
5 to 255	Reserved

5.3.5.4.4 Allocation choice

The attribute indicates the type of communication selected as shown in Table 50.

Table 50 – Allocation choice

Bit	7	6	5	4	3	2	1	0
Meaning	Reserved						I/O	Reserved

5.3.5.4.5 Node address switch changed

The attribute indicates if the node address switch has changed since the power-up.

5.3.5.4.6 Data rate switch changed

The attribute indicates if the data rate switch has changed since the power-up.

5.3.5.4.7 Node address switch value

The attribute indicates the current value of the node address switch.

5.3.5.4.8 Data rate switch value

The attribute indicates the current value of the data rate switch as shown in Table 51.

Table 51 – Data rate switch value

Value	Meaning
0	93,75 kbit/s
1	Reserved
2	1,5 Mbit/s
3	3 Mbit/s
4	4 Mbit/s
5 to 255	Reserved

5.3.5.4.9 Explicit message timer

This attribute is expressed in seconds.

5.3.5.4.10 Active node table

Instance attribute 11 of the CompoNet Link object shall consist of an array of 512 bits, one per MAC ID. The least significant bit shall correspond to MAC ID = 0, while the most significant bit shall correspond to MAC ID = 511. The bit for a specific MAC ID shall be set to “1”, if the node is in Participated state, which means the node can be accessed by Explicit Messages. The bit shall be cleared to “0” if the node is not in Participated state, which means the node can be missing, or in a state such as “Non-participated”, which means it does not support Explicit Messages.

5.3.5.4.11 Node state

Instance attribute 12, 13, 14, 15 and 16 indicate general state of all slave or repeater nodes. The bit definitions are shown in Table 52 and Table 53.

Table 52 – Bit definitions for node state octet

Bit (s)	Name	Definition
0-3	Node Network State	See Table 53
4	Communication Fault Flag	TRUE indicates there exists a communication fault error at the node address
5	Time Out Flag	TRUE indicates the master detected a connection timeout
6 to 7		Reserved, shall be 0

Table 53 – Bit definitions for node network state

Bits 0 to 3:	Node Network State Description
0 0 0 0	Nonexistent
0 0 0 1	Offline
0 0 1 0	Locked
0 0 1 1	Online
0 1 0 0	EventOnly
0 1 0 1	Communication Fault
0 1 1 0 through 1 1 1 1	Reserved

5.3.5.5 CompoNet Link object instance services

5.3.5.5.1 General

This subclause describes the common services and object class specific services supported by the CompoNet Link Object.

5.3.5.5.2 Common services

The required common services are specified in Table 54.

Table 54 – CompoNet Link object common services

Service code	Need in implementation	Service name	Description
0x0E	Required	Get_Attribute_Single	Returns the contents of the specified attribute.
0x10	Required	Set_Attribute_Single	Used to modify a CompoNet Link Object Attribute

5.3.5.5.3 Object class specific services

5.3.5.5.3.1 General

The CompoNet Link Object instance supports the following object class specific services in Table 55.

Table 55 – CompoNet Link Object class specific services

Service Code	Need In Implementation	Service Name	Service Description
0x4B	Conditional ^a	Allocate	Request the use of the Predefined Master/Slave Connection Set.
0x4C	Conditional ^b	Release	Indicates that the specified Connection(s) within the Predefined Master/Slave Connection Set are no longer desired. The indicated Connection(s) are to be released (Deleted).
^a This is required for slaves, optional for repeaters, and not allowed for masters. ^b This is required if Allocate is supported.			

5.3.5.5.3.2 Allocate (Service Code: 4B_{Hex})

Figure 44 is specified within the Service Data Field of an Allocate request.

Byte Offset	7	6	5	4	3	2	1	0
0	Allocation Choice							
1	Reserved							
2	Expected Packet Rate							(L)
3								(H)
4	Explicit message timer							(L)
5								(H)

Figure 44 – Allocate request service data

Allocation choice: The Allocation Choice parameter is specified within a single octet as shown in Table 56. Each bit denotes a Connection that is to be allocated. If the bit is set to one (1), then a request is being made to allocate that particular Connection. If a bit is set to zero (0), then the requester does not want to allocate that Connection.

Table 56 – Allocation choice octet contents

Bit	7	6	5	4	3	2	1	0
Meaning	Reserved						I/O	Reserved

When a slave or repeater receives an Allocate request, it shall confirm that nothing is set for reserved bits. The server shall ignore any request sent using the reserved bits and return an error.

Expected packet rate: This parameter is used as the EPR for allocated connection(s). The value is defined in Table 57.

Table 57 – EPR value

Value	Meaning
0x0000 to 0xFFFF	0x0000 selects the default. When the data rate is 93,75 kbit/s, the default value is 162 ms. For all other data rates, the default value is 50 ms. The resolution is 1 ms.

Explicit message timer: This value is used to override the default Explicit Message Timer defined in 5.2.4.3. See Table 58.

Table 58 – Explicit message timer

Value	Meaning
0x0000 to 0xFFFF	0x0000 selects the default. The resolution is in seconds.

Success response service data field parameters: The following information shown in Figure 45 is specified within the Service Data Field of a successful Allocate response.

Byte Offset	7	6	5	4	3	2	1	0
0	Reserved (00)							
1	Reserved (00)							

Figure 45 – Allocate response service data

Allocate service required server behaviour: This service is used to allocate connections as described in 5.3.4.4.4.2.

5.3.5.5.3.3 Release service (Service Code: 4C_{Hex})

This service is used to deallocate the indicated connections within a slave.

Request service data field parameters: The information shown in Figure 46 is specified within the Service Data Field of a Release request.

Byte Offset	7	6	5	4	3	2	1	0
0	Release Choice							

Figure 46 – Release request service data

The Service Data Field has the following information as shown in Table 59.

Table 59 – Release master/slave connection set request parameters

Name	Data type	Description
Release Choice	Octet	Designates which connections shall be released.

The Release Choice parameter is specified within a single octet as shown in Table 60. Each bit denotes a Connection(s) to be released. If the bit is set to one (1), then a request is being made to release that particular Connection. If a bit is set to zero (0), then the requester does not want to release that Connection.

Table 60 – Release choice octet contents

Bit	7	6	5	4	3	2	1	0
Meaning	Reserved						I/O	Reserved

When a server receives a Release request, it shall confirm that nothing is set for reserved bits. The server shall ignore any request sent using the reserved bits and return an error. A value of 00 is also invalid.

Success response service data field parameters: None.

5.3.5.5.4 Release master/slave connection set required server behaviour

This service is used to release connections as described in 5.3.4.4.

5.3.6 CompoNet Repeater object (class ID code: F8_{Hex})

5.3.6.1 General

This subclause contains the object descriptions for CompoNet Repeater Object.

5.3.6.2 Repeater class attributes

The Class attributes for the Repeater Object are defined below in Table 61.

Table 61 – Repeater class attribute

Number	Need in implementation	Access rule	Name	Data type	Description of attribute	Semantics of values
1 through 7	These class attributes are optional and are described in IEC 61158-5-2, 6.2.1.2.					

5.3.6.3 Repeater class services

The Repeater Object supports the following class services in Table 62.

Table 62 – Repeater class services

Service code	Need in implementation	Service name	Description
0x0E	Conditional ^a	Get Attribute Single	Used to read a repeater Object attribute.
^a Required if any Class attributes are supported.			

5.3.6.4 Instance attributes

5.3.6.4.1 General

The instance attributes of the Repeater object are defined as Table 63.

Table 63 – Instance attributes of repeater class

Attr No.	Need in implementation	Access rule	NV	Name	Data type	Description	Semantics of values
1	Required	Get	V	Slave Port Network Voltage	UINT		Unit: 100 mV
2	Required	Get	V	Slave port maximum network voltage	UINT		Unit: 100 mV
3	Required	Get	V	Slave port minimum Network Voltage	UINT		Unit: 100 mV
4	Required	Set	NV	Threshold for slave port Network Voltage	UINT		Unit: 100 mV
5	Required	Get	V	Master port Network Power On/Off	BOOL		5.3.6.4.6
NV non-volatile storage V volatile storage							

5.3.6.4.2 Slave port network voltage

This attribute shall correctly reflect the present voltage applied to the slave port at least from 0 V to 28 V d.c. The resolution of this attribute is 100 mV. If the voltage is over the measurement limits, the limit values shall be used.

5.3.6.4.3 Slave port maximum network voltage

The maximum slave port voltage detected since the reset. The resolution of this attribute is 100 mV.

5.3.6.4.4 Slave port minimum network voltage

The minimum slave port voltage detected since the reset. The resolution of this attribute is 100 mV.

5.3.6.4.5 Threshold for slave port network voltage

The resolution of this attribute is 100 mV. The default value is 140. If attribute 1 is lower than this threshold, the node shall report this situation to the master by setting Warning bit (B0 of Status) in CN frame. If this is not the only reason for the warning bit, the vendor shall provide information about the meaning of warning bit.

5.3.6.4.6 Master port network power on/off

This attribute becomes 1 when the voltage becomes greater than 21 V. It is 0 when the voltage is less than 3 V. It is 1 or 0 when the voltage is between 3 V and 21 V. Only the values 0 and 1 are allowed.

5.3.6.5 Instance services

This subclause describes the common services supported by the Repeater Object.

The common services are defined in Table 64.

Table 64 – Repeater common service

Code	Service	Description
0x05	Reset	Used to reset a Repeater Object attribute
0x0E	Get_Attribute_Single	Used to read a Repeater Object attribute
0x10	Set_Attribute_Single	Used to modify a Repeater Object attribute

The Reset service parameters are defined in Figure 47.

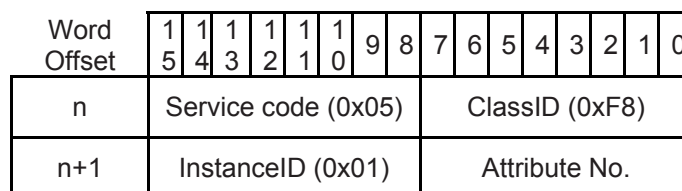

Figure 47 – Reset service parameter

The attributes supporting the reset service are listed in Table 65.

Table 65 – Reset attributes

Attribute No.	Name
2	Slave port Max Network Power Voltage
3	Slave port Min Network Power Voltage

5.4 Network access state machine

5.4.1 General

This subclause defines the Network Access State Machine that every product shall implement. The Network Access State Machine describes the following:

- network events that affect a product’s ability to communicate.
- tasks that are performed prior to communicating.

5.4.2 Network access events

The Network Access State Machine uses STR and STW B_EVENTS. A brief description of these follows:

STR: Using a B_EVENT frame, a master can conduct a status read operation to get information from a slave or a repeater. The status information includes:

- VendorID: CompoNet Vendor ID assigned by ODVA,
- SerialNumber: Vendor-managed device-unique number,
- RepeaterMode: True/False to indicate whether it is a repeater or a slave,
- InIoModeStatus: Status and length of input data,
- OutIoModeStatus: Status and length of output data,
- GateCount: the number of repeaters between this node and the master. This comes from the BEACON frame,
- LastRepeaterNodeAddress: the nearest repeater address. This comes from the BEACON frame.

STW: Using a B_EVENT frame, a master can set slave or repeater parameters by a status write operation. The parameters include:

- VendorID: CompoNet Vendor ID assigned by ODVA,
- SerialNumber: Vendor-managed device-unique number,
- CnTimeDomain: time to start CN transmission after OUT/TRG frame,
- InTimeDomain: time to start IN transmission after OUT/TRG frame,
- CnFrameAddressMask: indicates which slaves are permitted to send a CN frame in the current communication cycle,
- OutBlockPointer: 0 to 79. This indicates where in the OUT frame that output slaves get their data from,
- Running: Permission to perform normal online operations (participated/non-participated),
- UnRegistrant: Permission to perform duplicate address detection, and
- EventOnly: special online state used for configuration, parameterization, investigation, etc. (See Figure 50).

The following events determine the transitions that occur when processing the Network Access State Machine:

BEACON_OK: A BEACON frame was received with a valid CRC and a Speed Code that matches the present speed setting.

Network Timeout: A slave or repeater monitors the network communication with the network watchdog timer. In the Non-participated state the receipt of any correct frame retrigger the watchdog and prevents a timeout. In the Participated state an OUT or TRG frame shall be received. The timer is also retriggered when transitioning from the participated to non-participated states due to a network timeout event. The network watchdog timer's timeout value is determined by the data rate. See Table 66.

Table 66 – Data rate and network watchdog time periods

Data Rate	Network watchdog timer
4 Mbit/s; 3 Mbit/s; 1,5 Mbit/s	200 ms
93,75 kbit/s	650 ms

CN Counter Overflow: The CN frame counter is valid when the node is in the “non-participated” state with “UnRegistrant =0”. It increments by 1 when it replies with a CN frame to the master. If the value reaches 16, the node transitions to the Communication Fault state. The CN Counter is reset to 0 when the node enters the offline state.

There are several STW operations depending on parameter settings within the data field:

- **STW_Dup:** An STW whose VendorID or SerialNumber differs from the node's own values.
- **STW_Run:** An STW with “Running=1”, and whose VendorID and SerialNumber match the node's values.
 - **STW_Run Online:** If “EventOnly=0”
 - **STW_Run EventOnly:** If “EventOnly=1”
- **STW_Standby:** A STW with “Running=0” and whose VendorID and SerialNumber match the node's values; transitions the node to “Non-participated” state.
 - **STW_Standby Offline :** If “UnRegistrant =0”
 - **STW_Standby Locked:** If “UnRegistrant =1”

The sub-states of Online and EventOnly can not transition to each other directly. A STW with Run=1 and EventOnly=1 for a node at Online makes the node transition to Offline. A STW with Run=1 and EventOnly=0 for a node at EventOnly shall be ignored.

Important: Slave state transition shall be conducted within 500 µs after STW reception completes. Master Device shall allow 500 µs for slave state transition after STW transmission.

5.4.3 State transition diagram

An overview of network access is given here in Figure 48, Table 67, Figure 49 and Figure 50.

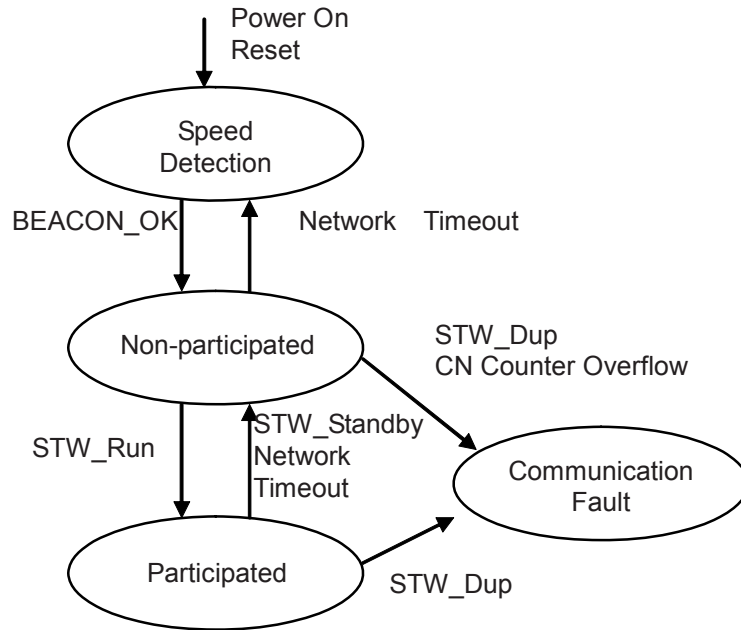

Figure 48 – State transition diagram

Table 67 – Description of the state machine

State		Description	Possible operations
Speed Detection		Initialization and data rate detection	Data rate detection
Non-participated	Offline	Waiting for participation permission from the master	Status-Read (STR) and Status-Write (STW) are possible; Non-participated CN frame is possible; Communication parameters are set by master's STW.
	Locked	Denied participation permission from the master	STR or STW; Non-participated CN.
Participated	Online	Participate in all network communications	All network operations
	EventOnly	Participate in Event communications only	Event communications
Communication Fault		Duplicate MAC ID fault is detected	Communication Fault CN frame.

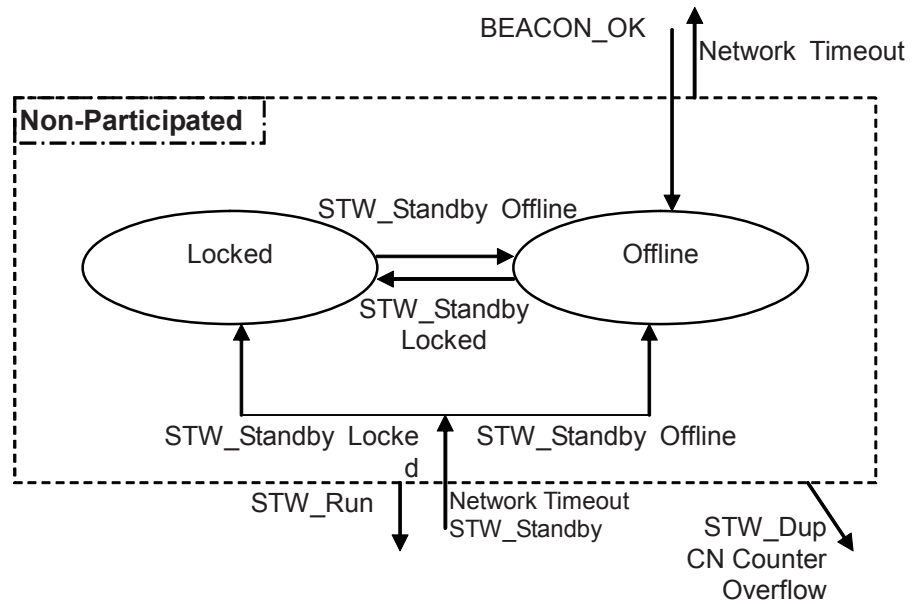

Figure 49 – Sub-state of non-participated state

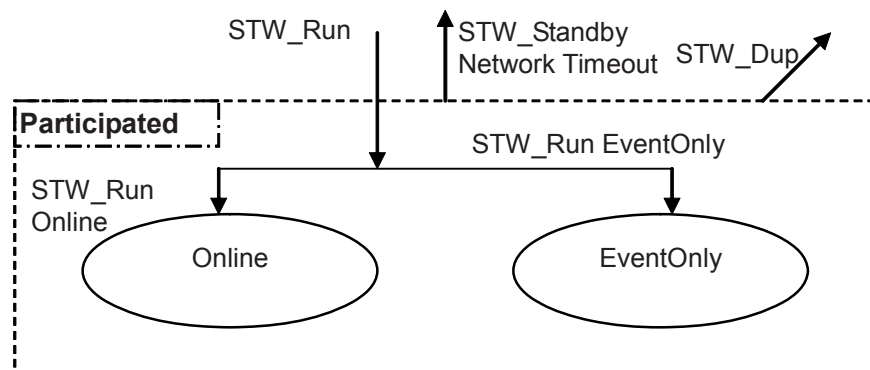

Figure 50 – Sub-state of participated state

Locked state: Nodes not configured by the master eventually transition to Communication Fault state. The master can prevent this by letting these nodes make a transition to the Locked state. The Locked state has the same LED indication pattern as the Offline state.

EventOnly state: A slave in the EventOnly state ignores the data in the OUT/TRG frame and does not reply with an IN frame. However, it can process Explicit Messages. This behaviour can be used for some applications. For example, a malfunctioning I/O node can be replaced online with a backup universal I/O node, if the universal I/O has a different default data length and the data length can be changed by explicit messages. The EventOnly state has the same LED indication pattern as the Online state.

5.4.4 Data rate auto-detection

Automatic detection of data rate is shown in Figure 51.

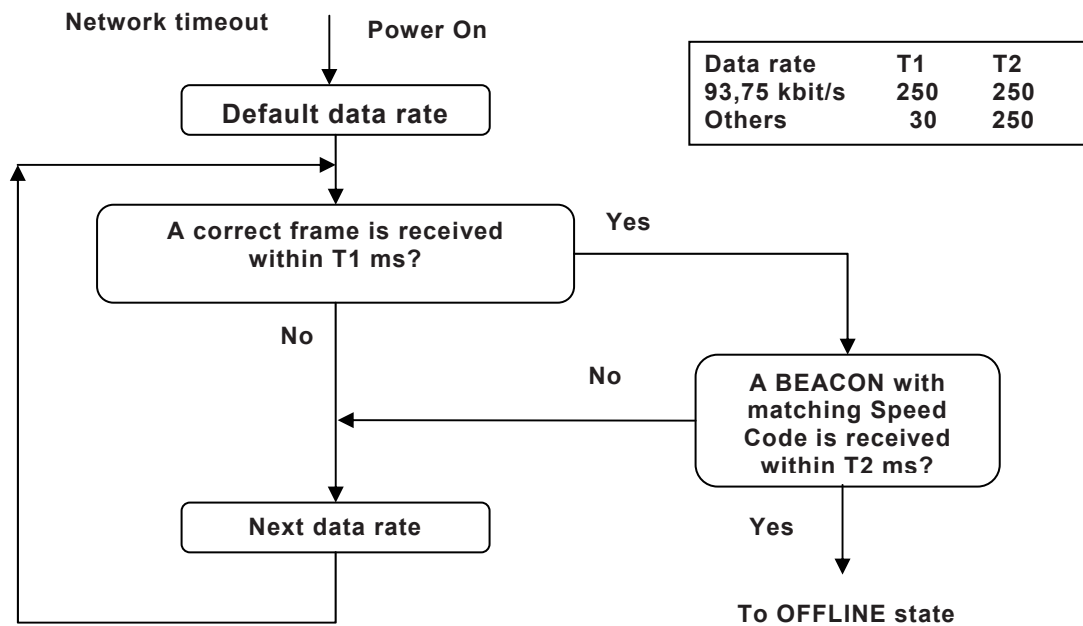

Figure 51 – Data rate detection diagram

The Speed code parameter of the BEACON shall be ignored in all states other than Speed Detection.

5.4.5 Duplicate MAC ID detection

There are three ways to detect a duplicate MAC ID; master detected, slave or repeater detected, and detected with an STW event.

The process begins when the master issues CN frame requests to collect information from the network. From the responses the master can determine if there is any overlap in the I/O data area. Some modules are required to occupy multiple MAC IDs because of their data size. For example a bit slave at MAC ID 128 with 4 bits of input data shall also consume MAC ID 129. However, the device reports its MAC ID at 128 in its CN frame response. If another node sends a CN frame response using MAC ID 129, the master identifies this node as a duplicate MAC ID.

A master may implement additional data overlap conditions to place a node into the Communication Fault state.

If multiple nodes exist at the same MAC ID, there is a possibility that the master cannot successfully receive CN frames from any nodes due to data collisions. The master continues to request CN frames from these devices. If the collisions continue to occur, the CN frame counter for the nodes exceeds its maximum (15). Then the node identifies itself as a duplicate MAC ID node.

If no data collisions occur and the master gets a CN frame response, the Master shall issue an STR to acquire the node's VendorId and SerialNumber. Once again if multiple nodes are using this MAC ID, and the STR attempts are unsuccessful, the node's CN frame counter eventually exceeds the maximum count. If the STR is successful, the condition would be detected when the master attempted to configure the node with an STW by sending an STW to the MAC ID using the VendorID and SerialNumber that it received in the STR response. All

devices that are using that MAC ID would receive this STW and all but one would identify themselves as duplicate MAC ID nodes due to the mismatched identity information. See Table 68.

Table 68 – Duplicate MAC ID detection mechanism

Detected by the master	The master detects an overlap in the I/O data area. The master forces the node into the Communication Fault state using an STW with a known incorrect VendorID number "0xFFFF" (STW_Dup).
Detected by a slave or repeater itself	If no STW is executed after receiving the specified number of CN-Frame requests for the node while in the Non-participated state, the node's CN Counter overflows and it enters the Communication Fault state. The CN-counter limit is 15. The Master may be able to detect the node in the Communication Fault state by sending a CN-Frame request to the duplicate address using a TRG or OUT frame.
Detected by STW	If the master can receive correct CN and STR responses from one of the nodes using a duplicate address, it sends a STW to that MAC ID. Other devices that are using that MAC ID enter the Communication Fault state after receiving the STW containing an incorrect VendorId or SerialNumber. The Master may be able to detect the node in the Communication Fault state by sending a CN-Frame request to the duplicate address using a TRG or OUT frame.

5.4.6 Repeater behaviour

Repeaters shall stop repeating or forwarding a frame if any error is found in the frame e.g. CRC error.

A Repeater is not transparent for all frames. Refer to Table 69 to determine which frames are repeated.

If the value of the Gate Count in the BEACON is less than 2, a repeater replaces the "Last Repeater Address" with its own address, and increases the Gate Count of the BEACON by one. The recalculated CRC covers the changes. If the Gate Count value is 2, the BEACON is not repeated. See Figure 52.

Table 69 – Repeating directions of frames

Direction	Frame type	Repeating action	Remarks
Downstream	OUT_frame	Yes	Repeat while receiving
	TRG_frame	Yes	Repeat while receiving
	A_EVENT	Yes	Repeat while receiving ^a
	B_EVENT	Yes	Repeat while receiving ^a
	CN_frame	No	
	IN_frame	No	
	BEACON_frame	Yes	Receive, modify and transmit
Upstream	OUT_frame	No	
	TRG_frame	No	
	A_EVENT	Yes	Repeat while receiving
	B_EVENT	Yes	Repeat while receiving
	CN_frame	Yes	Repeat while receiving
	IN_frame	Yes	Repeat while receiving
	BEACON_frame	No	
^a Repeating shall be stopped, if the message is destined to this repeater			

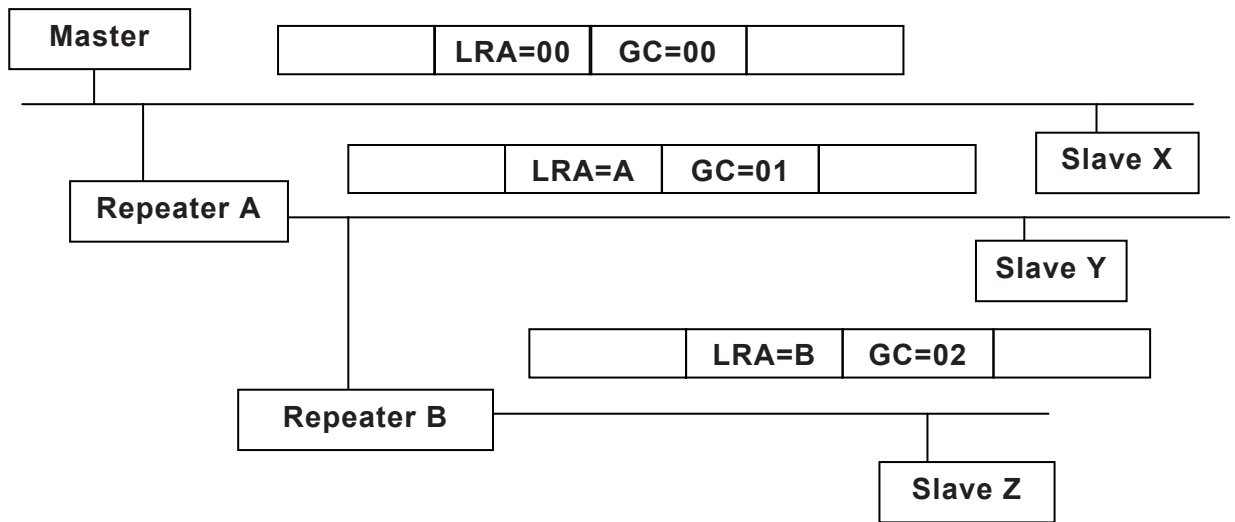

Key

- LRA Last Repeater node Address
- GC Gate Count

Figure 52 – BEACON changed by repeaters

5.5 I/O connection

CompoNet only supports unicast input and multicast output I/O connections. I/O connections do not support fragmentation. See Figure 53.

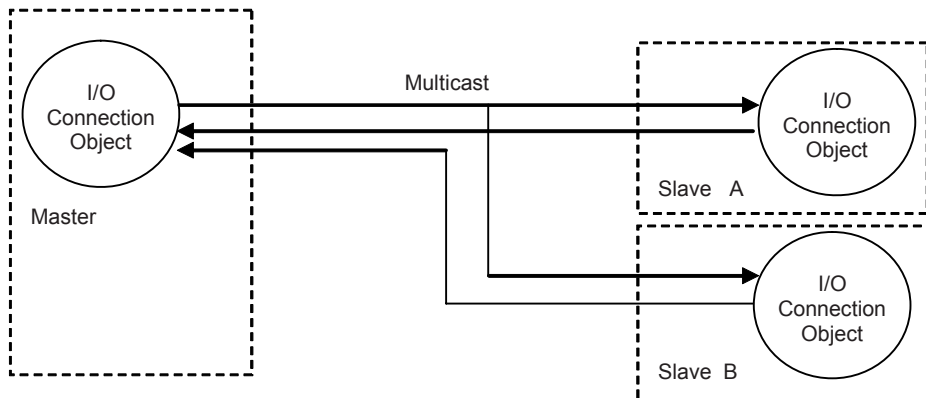

Figure 53 – Multicast I/O connections

The master uses an OUT frame to send output data to consuming slaves. The maximum output data size for a master is 1 280 bits. Producing slaves transmit input data to the master by using an IN frame. (See 5.2.2.1 and 5.2.2.4, for frame formats, and 5.1.3 for the communication pattern)

5.6 TDMA

5.6.1 General

This subclause defines timing specifications.

5.6.2 Data link timing features

5.6.2.1 Term definition

The following terms are used to describe timing features :

- **Receiving Delay:** The time from the completion of a frame until the frame is decoded correctly by MAC and indicated.
- **Transmitting Delay:** The time from the start of frame transmission by the upper layer into the MAC until the complete frame has been sent to the Physical Circuit.

5.6.2.2 Master timing features

The processing time in a master is affected by the MAC and the Physical Circuit as shown in Figure 54. A master shall conform to the time parameters shown in Table 70.

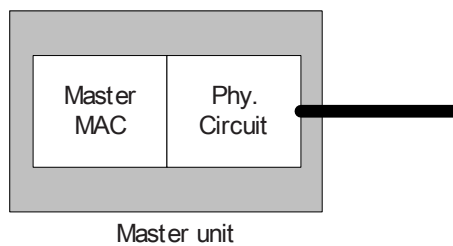

Figure 54 – Master MAC and Physical circuit diagram

Table 70 – Master timing features

Direction	Layer	Detail	MIN	MAX
Send and Receive	Master MAC	MAC delay	26 marks	30 marks
Send	Physical Circuit	Physical Transmitting delay ^a	0 ns	45 ns
Receive	Physical Circuit	Physical Receiving delay ^a	0 ns	105 ns
Send and Receive	Physical Circuit	Physical Circuit delay	0 ns	150 ns
^a See 5.7.3.5.				

Based on Table 70, the following times are obtained:

- *Master's Fixed Delay* (Fixed delay of master device): **26 marks**
- *Max of master's Variable Delay* (Fluctuation delay of master device): **4 marks + 150 ns**

5.6.2.3 Slave timing features

The processing time in a slave is affected by the MAC and the Physical Circuit as shown in Figure 55. A slave shall conform to the time parameters shown in Table 71.

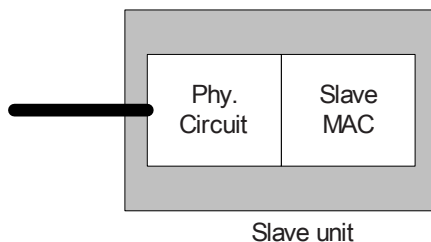

Figure 55 – Slave MAC and Physical circuit diagram

Table 71 – Slave timing features

Direction	Layer	Detail	MIN	MAX
Receive and Send	Slave MAC	MAC delay for frames except EVENT frames	26 marks	29 marks
Receive and Send	Slave MAC	MAC delay for EVENT frames except STW frames	25 marks	27 marks
Receive and Send	Slave MAC	MAC delay for STW frames	30 marks	32 marks
Send	Physical Circuit	Physical Circuit Transmitting delay	0 ns	45 ns
Receive	Physical Circuit	Physical Circuit Receiving delay ^a	0 ns	105 ns
Receive and Send	Physical Circuit	Physical Circuit delay	0 ns	150 ns
^a See 5.7.4.5.				

Based on Table 71, the following times are obtained:

- *Slave's Fixed Delay* (Fixed delay of slave device for OUT, BEACON, CN, IN frames): **26 marks**
- *Max of slave's Variable Delay* (Fluctuation delay of slave device for OUT, BEACON, CN, IN frames): **3 marks+150 ns**
- *Slave's Fixed Event Delay* (Fixed delay of slave device for A_EVENT and B_EVENT frames except STW frames): **25 marks**
- *Max of slave's Variable Event Delay* (Fluctuation delay of slave device for A_EVENT and B_EVENT frames except STW frames): **2 marks + 150 ns**
- *Slave's Fixed STW Delay* (Fixed delay of slave device for STW): **30 marks**
- *Max of slave's Variable STW Delay* (Fluctuation delay of slave device for STW): **2 marks + 150 ns**

5.6.2.4 Repeater timing features

The processing time in a repeater is affected by the MAC layer and Physical Circuit as shown in Figure 56. A repeater shall conform to the time parameters shown in Table 72.

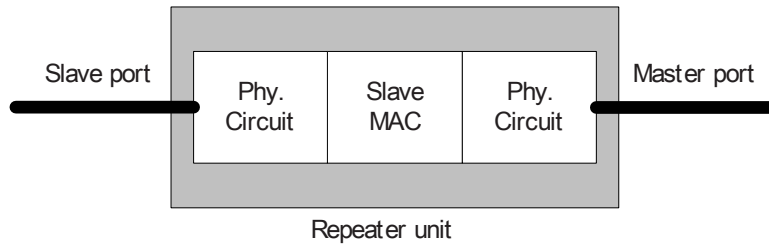

Figure 56 – Repeater MAC and Physical circuit diagram

Table 72 – Repeater timing features

Direction	Layer	Detail	MIN	MAX
Repeat	Slave MAC	MAC repeating delay	32 marks	35 marks
	Physical Circuit	Physical Circuit Repeating delay	0 ns	150 ns
Send	Physical Circuit	Physical Circuit Transmitting delay	0 ns	45 ns
Receive	Physical Circuit	Physical Circuit Receiving delay	0 ns	105 ns
Receive and Send	Slave MAC (Slave port)	MAC delay for frames except EVENT frames	See Table 71	
Receive and Send	Slave MAC (Slave port)	MAC delay for EVENT frames except STW frames		
Receive and Send	Slave MAC (Slave port)	MAC delay for STW frames		
Receive and Send	Physical Circuit (Slave port)	Physical Circuit delay		

Based on Table 72, the following times are obtained:

- *Fixed Repeating Delay* (Fixed delay in repeating): **32 marks**
- *Max of Variable Repeating Delay* (Fluctuation delay in repeating): **3 marks + 150 ns**

5.6.2.5 Cable propagation delay

The cable used shall conform to the time parameters shown in Table 73.

Table 73 – Cable propagation delay

Description	MIN	MAX
Cable propagation delay	0 ns/m	8 ns/m

Based on Table 73, the following times are obtained:

$$\text{Total Cable Delay Max} = 8 \text{ ns/m} \times \text{Maximum Cable Length}$$

where Maximum Cable Length is defined in Table 74.

Table 74 – Maximum cable length

Data rate	Specification length m	Calculating length m
4 Mbit/s	30	30
3 Mbit/s	30,5	31
1,5 Mbit/s	100	203
93,75 kbit/s	506	506

5.6.2.6 Transmission process

Figure 57 shows the transmission process.

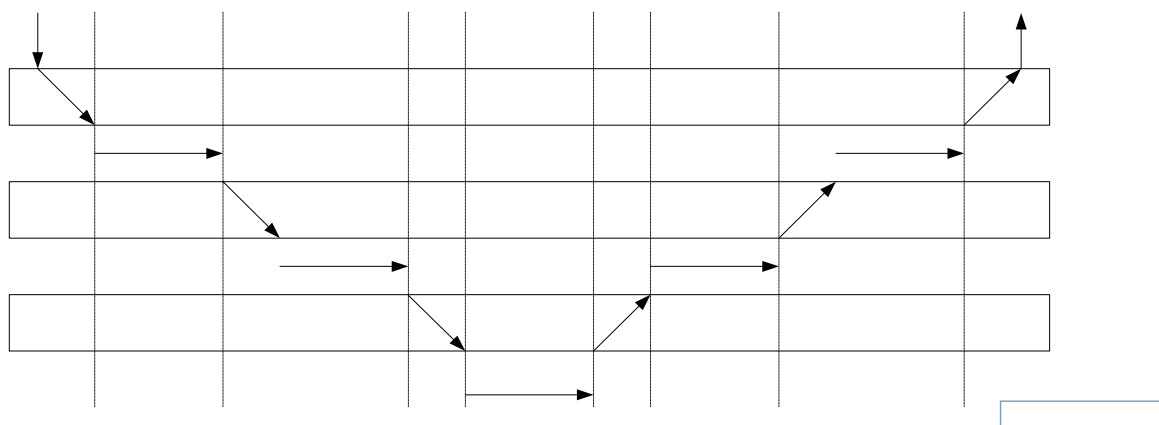

Figure 57 – Transmission process

5.6.3 Calculation of Time Domain

5.6.3.1 Term definition

Parameters used for Time Domain calculation are shown in Table 75.

Table 75 – Parameters in TimeDomain calculation

Parameters	Definition	Value
Efficiency	Manchester conversion efficiency, 1 bit = 2 marks	2
Frequency variation	±500 parts per million	1 001/1 000
Repeater fixed delay	Fixed Repeating Delay	32 marks
Fixed delay	=(Master's Fixed Delay) + (Max of Master's Variable Delay) + (Slave's Fixed Delay)	56 marks + 150 ns
Fluctuation delay	=(Max of slave's Variable Delay) + [(Total Cable Delay Max) × 6] + [(Max of Variable Repeating Delay)x 4]	750 ns + [(Total Cable Delay Max)x 6] ns + 15 marks
Margin correction	Margin of IN/CN frame frequency deviation, Max.: 0,57 marks	1 mark

Parameters	Definition	Value
	Margin of frequency calculation for each frame position, Max.: 0,07 marks Total=0,57+0,07=0,64 marks	

5.6.3.2 Frame marks

The marks of frames are listed in Table 76.

Table 76 – Frame marks

Frame	Standard marks
BEACON	$(5 + 5 + 2 + 3 + 6 + 2 + 8) \times 2 = 62$ marks
OUT	$(5 + 7 + 9 + 7 + Nwo \times 16 + ((Nbo + 7) / 8) \times 16 + 16) \times 2 = 88 + (Nwo + ((Nbo + 7) / 8)) \times 32$ marks
TRG	$(5 + 7 + 9 + 8) \times 2 = 58$ marks
CN (CN_Std_Marks)	$(5 + 4 + 9 + 4) \times 2 = 60$ marks
WordIN (WordIN_Std_Marks)	$(5 + 2 + 9 + 5 + 16 + 8) \times 2 = 90$ marks
BitIN (BitIN_Std_Marks)	$(5 + 2 + 9 + 5 + 2 + 8) \times 2 = 62$ marks
EVENT	$(5 + 6 + 9 + 9 + 5 + Ned \times 8 + 16) \times 2 = 100 + Ned \times 16$ marks

NOTE 1 Nwo is the total number of words in a word output slave.
NOTE 2 Nbo is the total number of nodes in a bit output slaves.
NOTE 3 Ned is the event data length of an EVENT frame in octets.

5.6.3.3 CN Time Domain and In Time Domain

The transmission cycle model is shown in Figure 58. In this model, it is necessary to multiply the frequency variation at each frame position.

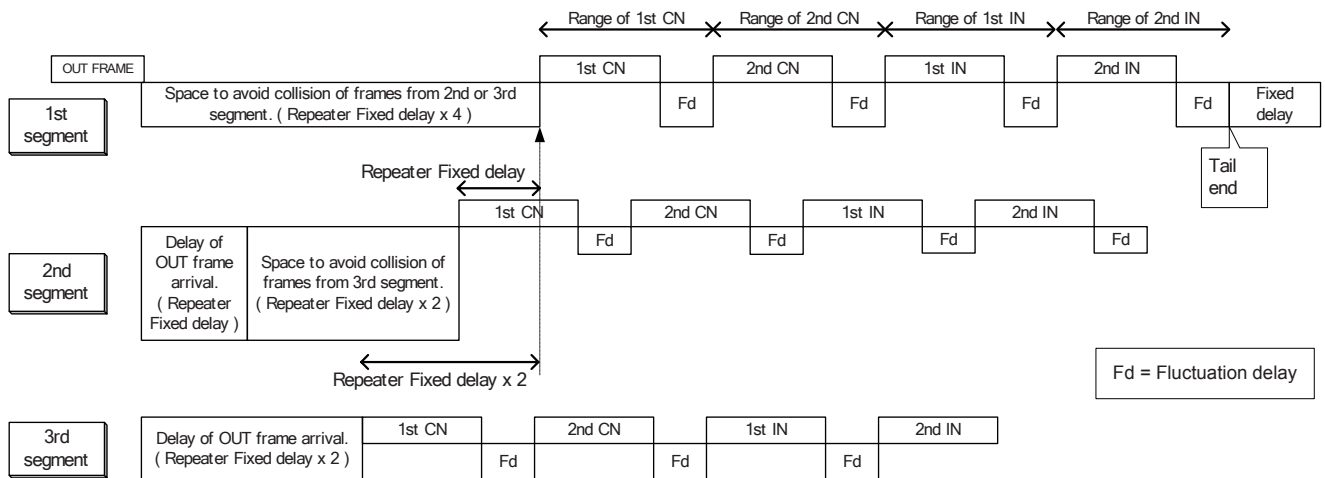

Figure 58 – Transmission cycle model

After power-on or a physical reset, slaves and repeaters get to know the segment layers they are connected to by “Gate Count” value of BEACONS received. The default CN time domain is discussed in 5.6.3.4.

The master in a network can change the number of CN frames in a bus cycle according to its own schedule policy. The master calculates timing of all other nodes and sends it to slaves and repeaters by STW. Table 77 and Table 78 present how to calculate CN Time Domain and In Time Domain informatively.

Table 77 – TimeDomain settings for nodes at first segment layer

Setting	Time Domain at the 1st segment layer
CN#0	'Repeater Fixed delay' × 4
CN#1	(CN#0+CN_Std_Marks + 'Fluctuation delay' + 'Margin correction') × 'Frequency variation'
CN#(cn_last)	(CN#(cn_last-1) + CN_Std_Marks + 'Fluctuation delay' + 'Margin correction') × 'Frequency variation'
WordIN#0	(CN#(cn_last) + CN_Std_Marks + 'Fluctuation delay' + 'Margin correction') × 'Frequency variation'
WordIN#(win_last)	(WordIN#(win_last-1) + WordIN_Std_Marks + 'Fluctuation delay' + 'Margin correction') × 'Frequency variation'
BitIN#0	< When WordIN exists > (WordIN#(win_last) + WordIN_Std_Marks + 'Fluctuation delay' + 'Margin correction') × 'Frequency variation' < When WordIN doesn't exist > (CN#(cn_last) + CN_Std_Marks + 'Fluctuation delay' + 'Margin correction') × 'Frequency variation'
BitIN#(bin_last)	(BitIN#(bin_last-1) + BitIN_Std_Marks + 'Fluctuation delay' + 'Margin correction') × 'Frequency variation'
Tail end	< When WordIN exists in the end > (WordIN#(win_last) + WordIN_Std_Marks + 'Fluctuation delay' + 'Margin correction') × 'Frequency variation' < When BitIN exists in the end > (BitIN#(win_last) + BitIN_Std_Marks + 'Fluctuation delay' + 'Margin correction') × 'Frequency variation' < When both WordIN/BitIN doesn't exist in the end > (CN#(cn_last) + CN_Std_Marks + 'Fluctuation delay' + 'Margin correction') × 'Frequency variation'

Table 78 – TimeDomain settings for nodes at 2nd and 3rd segment layers

Setting	TimeDomain at 2nd segment Layer	TimeDomain at 3rd segment layer
CN#n	CN#n(1st segment) – RFD × 2	CN#n(1st segment) – RFD × 4
IN#n	WordIN#n(1st segment) – × 2	WordIN#n(1st segment) – RFD × 4
BitIN#n	BitIN#n(1st segment) –RFD × 2	BitIN#n(1st segment) –RFD × 4
NOTE RFD is repeater fixed delay.		

5.6.3.4 CnDefaultTimeDomain

Figure 59 indicates the CnDefaultTimeDomain cycle model.

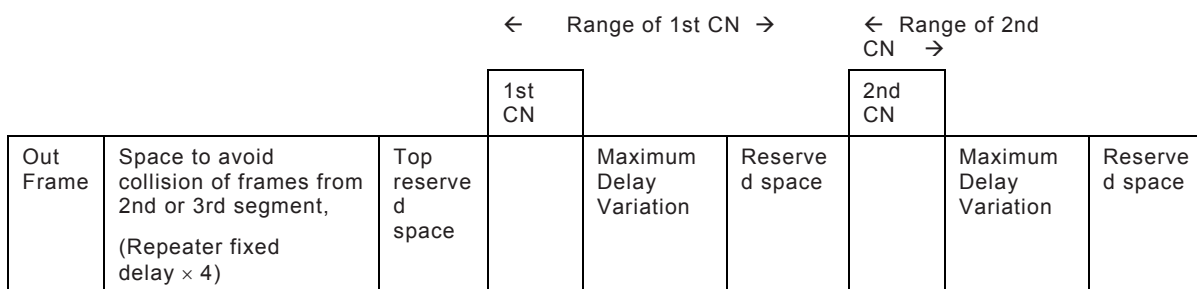

Figure 59 – CnDefaultTimeDomain cycle model

In order to give a safe margin, i.e. reserved space, 1 mark has been inserted before and after MAC Repeater delay when CnDefaultTimeDomain was calculated for a Repeater.

Table 79 – Repeater delay for CnDefaultTimeDomain calculation

Direction	Layer	Detail	MIN	MAX
Repeat	Slave MAC	MAC repeater delay	32 marks	36 marks
	Physical Layer	Physical layer repeater delay	0 ns	150 ns

Based on the Table 79, the times in Table 80 can be used to obtain:

- *Modified Max of Variable Repeating Delay* (Fluctuation delay in repeating): **4 marks + 150 ns.**

Table 80 – Parameters for CnDefaultTimeDomain calculation

Items	Definition	Value
Efficiency	Manchester conversion efficiency 1 bit=2 marks	2
Frequency variation	±500 parts per million	1 001/1 000
Repeater Fixed delay	Fixed Repeating Delay = 32 mark	32 marks
Top reserved space	Reserved space	26 marks
Reserved space	Reserved space	4 Mbit/s: 18 marks 3 Mbit/s: 19 marks 1,5 Mbit/s: 21 marks 93,75 kbit/s: 23 marks
Maximum Delay Variation	(Max of slave's Variable Delay) + [(Total Cable Delay Max)x 6] + [(Modified Max of Variable Repeating Delay)x 4] + (Margin correction) 4 Mbit/s:750/125+20+[(8x30)/125] × 6 = 38 mark 3 Mbit/s: 750/166+20+[(8x31)/166] × 6 =37 mark 1,5 Mbit/s:750/333+20+[(8x203)/333] × 6 =53 mark 93,75 kbit/s: 750/5 347+20+[(8x506)/5 347] × 6 =27 mark	4 Mbit/s: 38 marks 3 Mbit/s 37 marks 1,5 Mbit/s: 53 marks 93,75kbit/s: 27 marks

<p>NOTE</p> <p>125 ns is the length of 1 mark at 4 Mbit/s.</p> <p>166 ns is the length of 1 mark at 3 Mbit/s.</p> <p>333 ns is the length of 1 mark at 1,5 Mbit/s.</p> <p>5 347 ns is the length of 1 mark at 93,75 kbit/s.</p>

All slaves or repeaters shall use CnDefaultTimeDomain values calculated by the method shown in Table 81 and Table 82. Rounded values are presented in Annex G.

Table 81 – First segment layer settings

Setting	Time Domain at 1st segment layer
CN#0	(Repeater Fixed delay) × 4 + Top reserved space
CN#1	(CN#0 + CN_Std_Marks + 'Reserved space' + 'Maximum Delay Variation') × 'Frequency variation'
CN#(cn_last)	[CN#(cn_last-1) + CN_Std_Marks + 'Reserved space' + 'Maximum Delay Variation'] × 'Frequency variation'

Table 82 – Settings for 2nd and 3rd segment layers

Setting	Time Domain at the 2nd segment layer	Time Domain at the 3rd segment layer
CN#n	CN#n(1st segment) – RFD × 2	CN#n(1st segment) – RFD × 4
NOTE RFD stands for repeater fixed delay.		

5.6.3.5 Event Time Domain

This subclause illustrates how to calculate timing for EVENT communication informatively. A model for the master is shown in Figure 60.

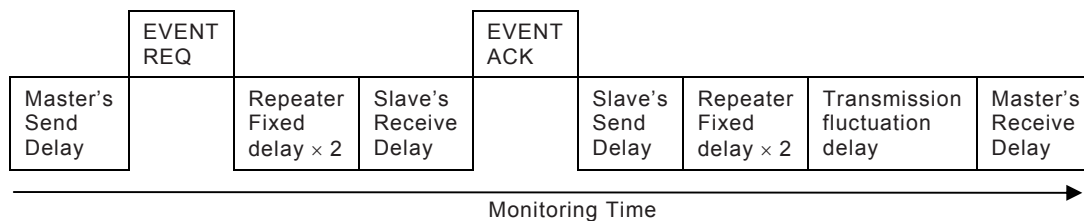

Figure 60 – Master event communication model

The Event Time Domain length is calculated by the following formula and the with parameters show in Table 83.

- 'Master's Send Delay'
- + 'EVENT REQ Length' × 'Frequency variation'
- + 'Repeater Fixed delay' × 2
- + 'Slave's Receive Delay'
- + 'EVENT ACK Length' × 'Frequency variation'
- + 'Slave's Send Delay'
- + 'Repeater Fixed delay' × 2
- + 'Transmission fluctuation delay'
- + 'Master's Receive Delay'

For a repeater or a slave, Figure 61 shows an Event communication model informatively.

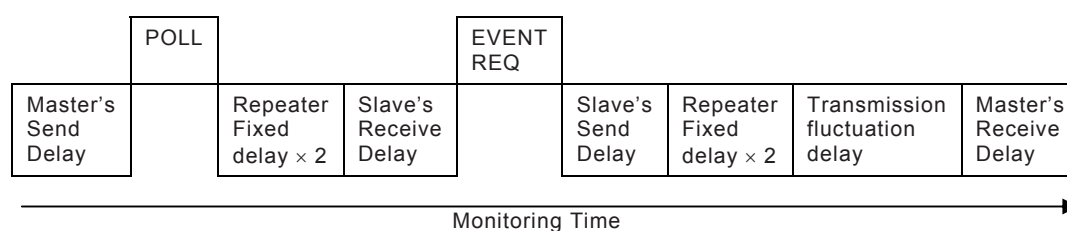

Figure 61 – Slave event communication model

The Event Time Domain length is calculated by the following formula and the parameters shown in Table 83.

- 'Master's Send Delay'
- + 'POLL Length' × 'Frequency variation'
- + 'Repeater Fixed delay' × 2
- + 'Slave's Receive Delay'
- + 'EVENT REQ Length' × 'Frequency variation'
- + 'Slave's Send Delay'
- + 'Repeater Fixed delay' × 2
- + 'Transmission fluctuation delay'
- + 'Master's Receive Delay'

Table 83 – Parameters for Event Time Domain calculations

Parameter	Value
Master's Send Delay	'Master's Send Delay'+ 'Master's Receive Delay'
Master's Receive Delay	= 'Master's Fixed Delay'+ 'Max of Master's Variable Delay' = 30 marks + 150ns (See Table 70)
Slave's Receive Delay	'Slave's Receive Delay'+ 'Slave's Send Delay':
Slave's Send Delay	EVENT frames except STW: 27 marks + 150 ns B_EVENT STW frames: 32 marks + 150 ns (See Table 71)
EVENT REQ Length	STR request :132 marks STW request :420 marks A_EVENT :804 marks (max) (See 5.2)
POLL Length	POLL : 132 marks (See 5.2)
EVENT ACK Length	STR response : 388 mark STW response : 132 marks A EVENT ACK : 100 marks (See 5.2)
Repeater Fixed delay	Fixed Repeating Delay: 32 marks (See Table 72)
Transmission fluctuation delay	'Total Cable Delay Max' × 6 + 'Max of Variable Repeating Delay' × 4 =600 ns+(' Total Cable Delay Max ' × 6) ns+12 marks

Parameter	Value
	(See 5.6.2.5 and 5.6.2.3)
Frequency variation	1 001/1 000 (See Table 75)

5.7 Physical layer

5.7.1 General

This subclause specifies the physical layer.

5.7.2 Physical signalling

CompoNet uses Manchester encoding technology. Two symbols represent one inverted Manchester encoded bit. See Figure 62 and Table 84

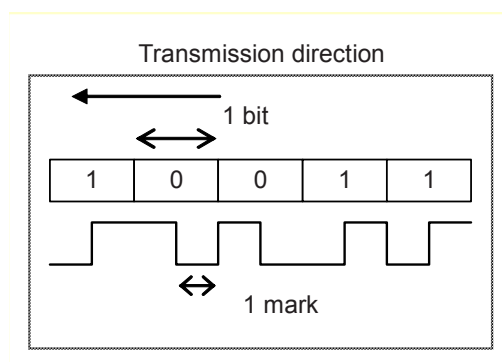

Figure 62 – Manchester encoding (inverted)

Table 84 – CompoNet Manchester encoding

Symbols (marks)	Meanings	Manchester encoded symbols (inverted)
{H,L}	Data 0	0
{L,H}	Data 1	1
{L,L}{H,H}	Illegal	-

5.7.3 Master port requirements

5.7.3.1 Master port connectors

Table 85 indicates allowable connectors for the master port.

Table 85 – Allowable connectors for the master port

Connector	Open	Flat I	Flat II
Master	Jack	Jack	Jack

NOTE Permanently attached cables² at the master port are not allowed.

² Permanently attached cable is cable that extends from a device for purposes of connectivity to the network and can not be unclipped or removed by a user without special tools.

5.7.3.2 Master port power

When power is supplied by a master port to downstream slaves on its segment, the power shall be provided by one of two methods,

- an internal power supply connecting to the network through the master port, or
- an external power supply connecting to the network either through a dedicated set of power terminals on the master or at the master port plug as shown in 5.7.11.2.2. In all cases the power connections and distances at the master port shall conform to 5.7.11.1.1.

When power is provided externally at the master port plug, an open style plug shall be used.

The power supply specifications at the master port shall conform to Table 110.

5.7.3.3 Impedance for master ports

All master ports shall conform to the impedance limits as defined as Table 86 and Table 87.

Table 86 – Master port impedance during receive

Frequency MHz	Impedance Ω	
	Minimum	Maximum
0,75	140	163
1	139	162
1,5	137	159
3	125	146
4	116	135

Table 87 – Master port impedance during transmit

Frequency MHz	Impedance Ω	
	Minimum	Maximum
0,75	81	94
1	83	97
1,5	86	100
3	91	106
4	92	108

5.7.3.4 Master port requirements

5.7.3.4.1 Transmit signal requirements

A master port shall transmit signals complying with the requirements shown as Figure 63, Table 88 and Table 89 when configured in accordance with Figure 64. For details, see Clause 9.

The vertical axis in the following figures is ($V_{BDH} - V_{BDL}$).

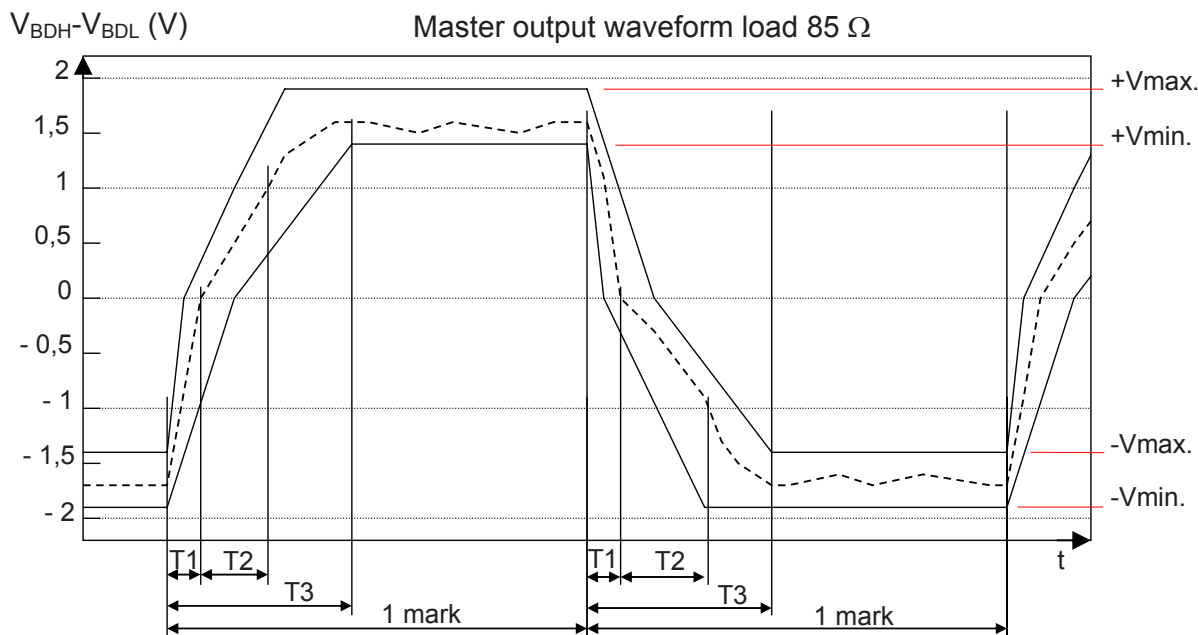

Figure 63 – Master port transmit mask

Table 88 – Master port transmit specifications for data rate of 4 Mbit/s, 3 Mbit/s and 1,5 Mbit/s

Sign	Limits characteristics	Comments
+ Vmax	1,90 V	
+ Vmin	1,40 V	
- Vmax	-1,40 V	
- Vmin	-1,90 V	
T1	11 ns to 27 ns	Cross at 0 V
T2	8 ns to 32 ns	Start at 0 V, Cross at -1,0 V downward, or 1,0 V upward
T3	75 ns	Waveform voltage value between + Vmin to + Vmax, or - Vmin to + Vmax
T3 - Data inverted point	- Vmin to - Vmax, or + Vmin to + Vmax	

Table 89 – Master port transmit specifications for data rate of 93,75 kbit/s

Sign	Limits characteristics	Comments
+ Vmax	1,90 V	
+ Vmin	1,40 V	
- Vmax	-1,40 V	
- Vmin	-1,90 V	
T3	1/8mark	Waveform voltage value between + Vmin to + Vmax, or - Vmin to + Vmax
T3 to Data inverted point	-Vmin to - Vmax, or +Vmin to +Vmax	

Figure 64 indicates how the transmit mask is measured. The resistor shall be metal film type or carbon film type.

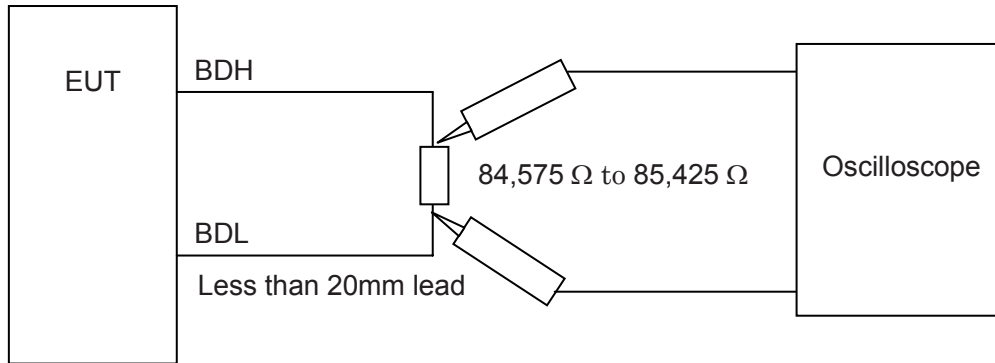

Figure 64 – Output waveform test circuit for master or slave port

5.7.3.4.2 Master port receive conformance signal requirements

The receiver shall conform to 5.7.5.

5.7.3.5 Master port physical circuit delay

The master port physical circuit shall conform to the following:

- maximum delay when transmitting is 45 ns;
- maximum delay when receiving is 105 ns.

5.7.4 Slave port requirements

5.7.4.1 Slave connectors

A slave shall be fitted with a permanently attached cable or one of the jacks defined in Table 91. In the case of a permanently attached cable, the cable shall be cut to the specified length and fitted with one of the plugs defined in Table 90. The finished length of the permanently attached cable shall be in accordance with Table 108.

The length of the permanently attached cable shall be at least 50 cm.

Table 90 – Allowable connectors for permanently attached cables

Connector	Flat I	Flat II
Slave	Plug ^a	Plug ^a
^a When a permanently attached connection is used, a plug shall be provided at the end of the permanently attached cable in place of the jack.		

Table 91 – Allowable connectors for the slave port

Connector	Open	Flat I	Flat II
Slave	Jack	Jack	Jack

A network designed for 4 Mbit/s shall not include slaves with permanently attached cables.

Slaves with permanently attached cables shall be marked to indicate that they cannot be used on network configurations that do not allow T-branches.

5.7.4.2 Slave power

A slave may be powered by one of two ways, either from the network or an external power supply.

A node powered by network power supply shall comply with the requirements in Table 110.

When an external power supply is used, the local power supplies connected to the slave port shall comply with Table 111. The power supply shall provide isolation from its power source in accordance with 5.7.11.1.3.

5.7.4.3 Impedance for slave ports

All slave ports shall conform to receive and transmit limits shown in Table 92 and Table 93.

Table 92 – Slave port impedance during receive

Frequency MHz	Impedance Ω	
	Minimum	Maximum
0,75	847	985
1	821	955
1,5	754	877
3	558	649
4	477	554

Table 93 – Slave port impedance during transmit

Frequency MHz	Impedance Ω	
	Minimum	Maximum
0,75	137	160
1	143	166
1,5	154	180
3	181	210
4	194	225

5.7.4.4 Slave port requirements

5.7.4.4.1 Transmit signal requirements

A slave port shall transmit signals complying with the requirements shown as Figure 65, Table 94 and Table 95 when configured in accordance with Figure 64. For details, see Clause 9.

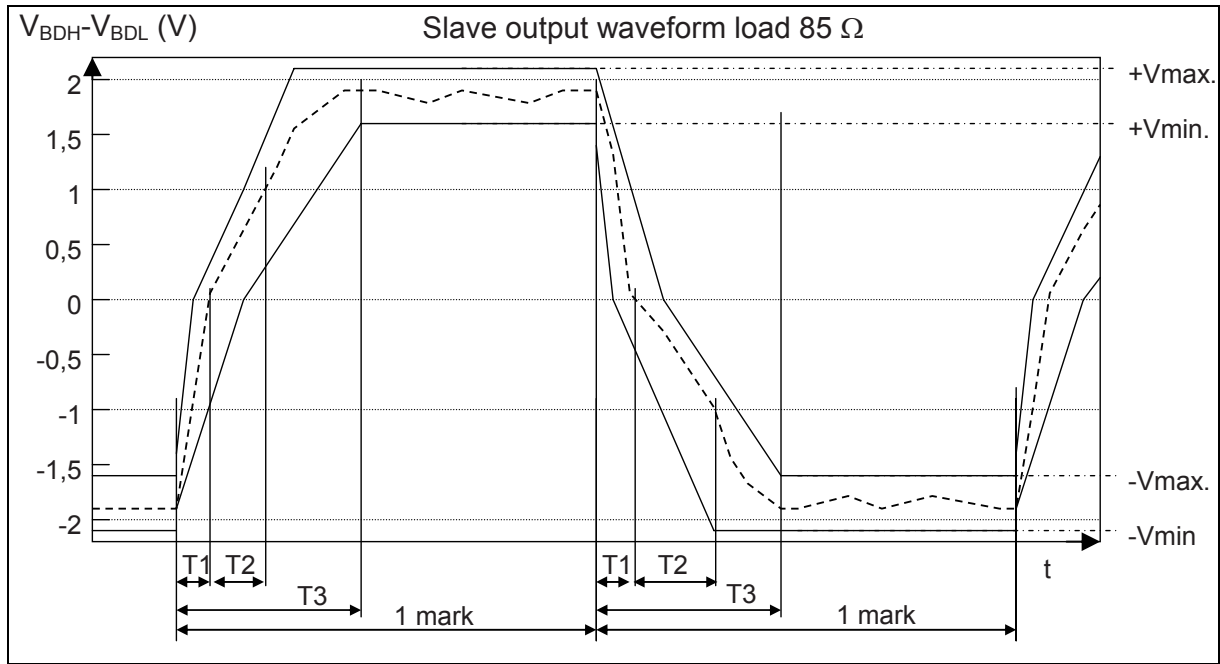

Figure 65 – Slave port transmit mask

Table 94 – Slave port transmit specifications for data rate of 4 Mbit/s;
3 Mbit/s and 1,5 Mbit/s

Sign	Limits characteristics	Comments
+ Vmax	2,12 V	
+ Vmin	1,57 V	
- Vmax	-1,57 V	
- Vmin	-2,12 V	
T1	8 ns to 18 ns	Cross at 0 V
T2	5 ns to 20 ns	Start at 0 V, Cross at -1,0 V downward, or 1,0 V upward
T3	75 ns	Period from - Vmin or + Vmax, to + Vmin or - Vmax
T3 to Data inverted point	-Vmin to - Vmax, or + Vmin to + Vmax	

Table 95 – Slave port transmit specifications for data rate of 93,75 kbit/s

Sign	limits characteristics	Comments
+ Vmax	2,12 V	
+ Vmin	1,57 V	
- Vmax	-1,57 V	
- Vmin	-2,12 V	
T3	75 ns	Waveform voltage value between + Vmin to + Vmax, or - Vmin to + Vmax
T3 to Data inverted point	- Vmin to - Vmax, or + Vmin to + Vmax	

Measurement methods for the slave transmit mask are covered in Clause 9.

5.7.4.4.2 Slave port receive signal requirements

The receiver shall conform to 5.7.5.

5.7.4.5 Slave port physical circuit delay

The slave port physical circuit shall conform to the following:

- maximum delay when transmitting is 45 ns.
- maximum delay when receiving is 105 ns.

5.7.5 Receiving signal requirements for master and slave ports

The receiver shall properly decode the following signals as defined in Figure 66, Figure 67 and Figure 68, and report these events to the MAC/Phy interface in accordance with respective MAC/Phy signals shown in Figure 70, Figure 71 and Figure 72.

The vertical axis in following figures is $(V_{BDH} - V_{BDL})$.

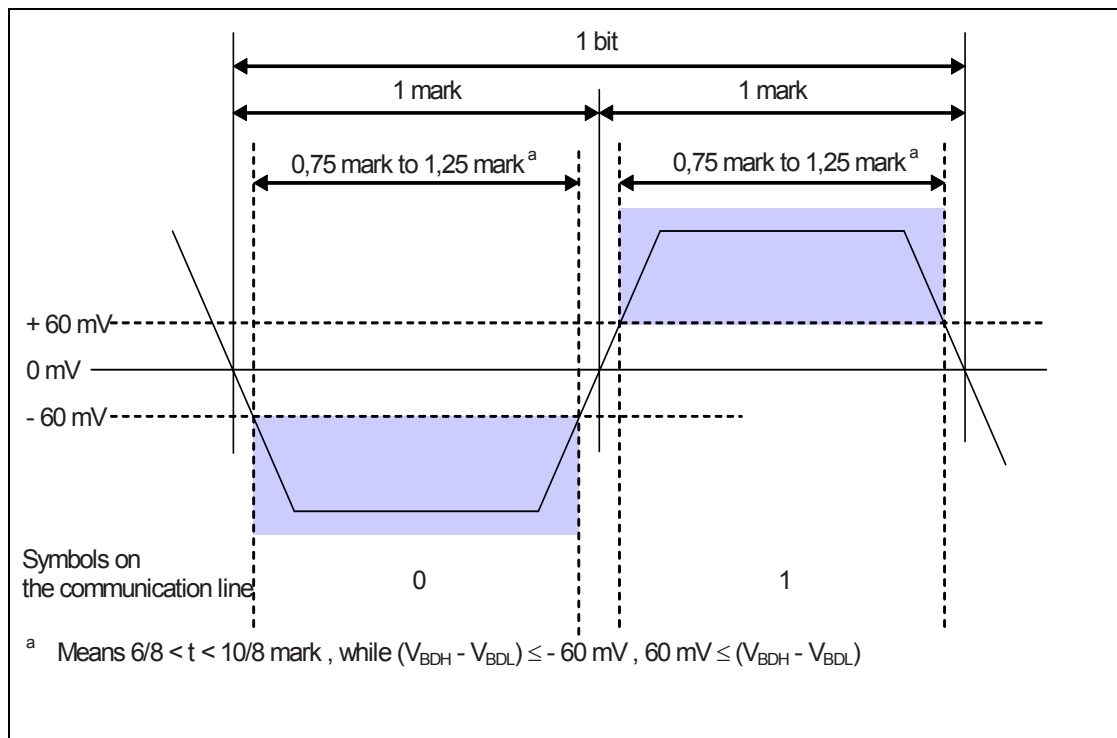

Figure 66 – Receive mask 1

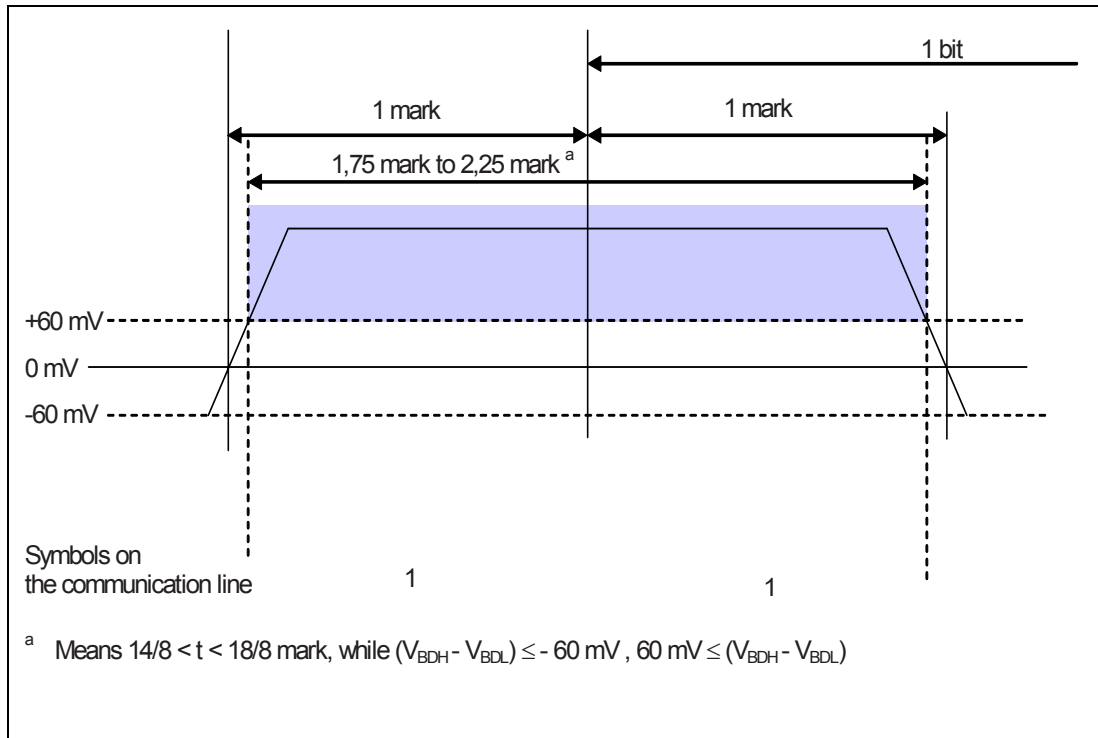

Figure 67 – Receive mask 2

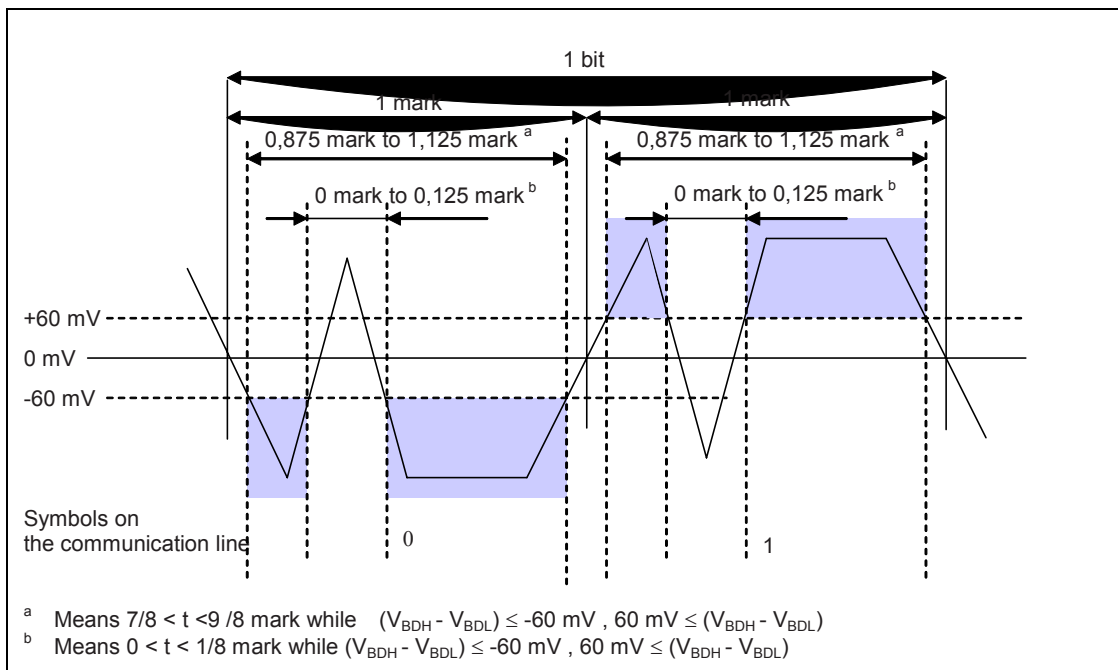

Figure 68 – Receive mask 3

5.7.6 Requirements for digital processing

5.7.6.1 General

This subclause describes requirements for digital processing at the internal PHY/MAC interface as shown in Figure 69.

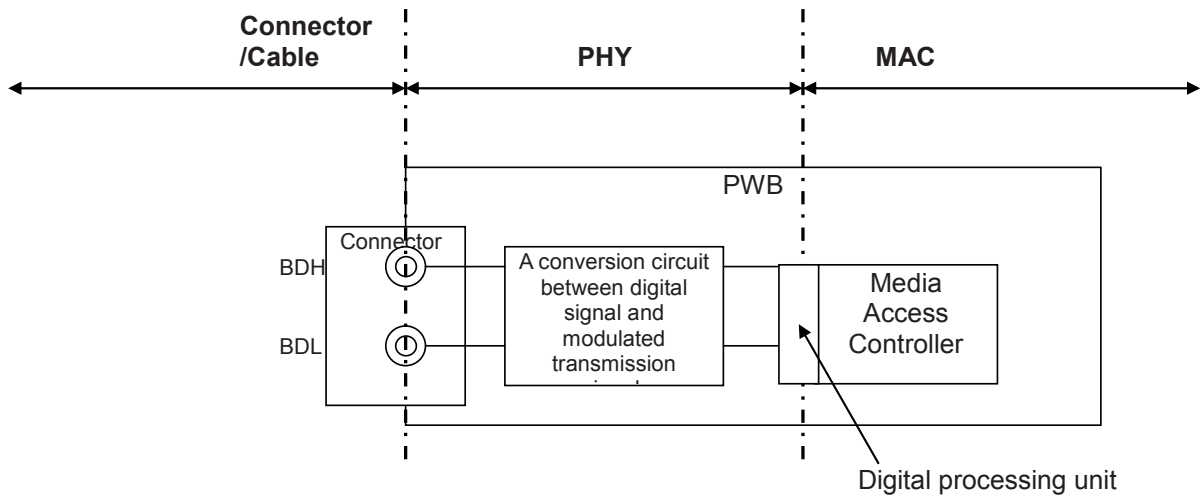

Figure 69 – PHY/MAC interface diagram

5.7.6.2 Receive processing requirements

The MAC/PHY interface levels are application specific. The PHY shall decode the network Manchester symbols and report them to the MAC/PHY interface in accordance with Table 96, Table 97, Table 98, Figure 70, Figure 71 and Figure 72.

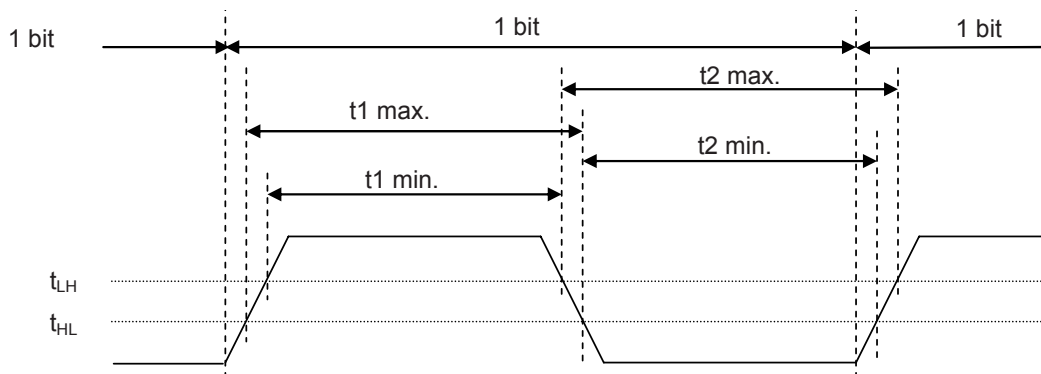

Figure 70 – Digital receive mask 1

Table 96 – Specifications for digital receive mask 1

Item	Restriction	Typical Value
$T1 \square t1_{max} - t1_{min} \square$	$5/8 [\text{mark}] + 0,5 \text{ ns} \leq T1$ $T1 \leq 11/8 [\text{mark}] - 0,5 \text{ ns}$	1 [mark]
$T2 \square t2_{max} - t2_{min} \square$	$5/8 [\text{mark}] + 0,5 \text{ ns} \leq T2$ $T2 \leq 11/8 [\text{mark}] - 0,5 \text{ ns}$	1 [mark]
NOTE This table applies to Figure 70 and the inversion of the signal pattern shown in Figure 70.		

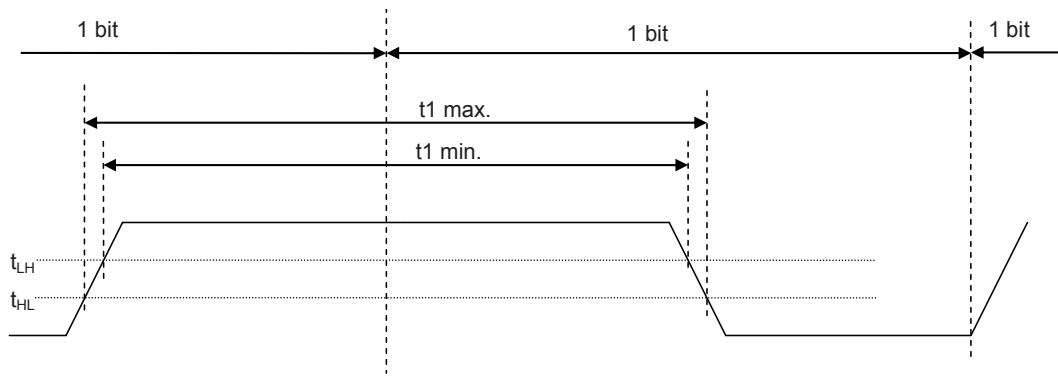

Figure 71 – Digital receive mask 2

Table 97 – Specifications for digital receive mask 2

Item	Regulation	Typical Value
$T \square t1_{max} - t1_{min} \square$	$13/8 [\text{mark}] + 0,5 \text{ ns} \leq T \leq 19/8 [\text{mark}] - 0,5 \text{ ns}$	1 [mark]
NOTE This table applies to Figure 71 and the inversion of the signal pattern shown in Figure 71.		

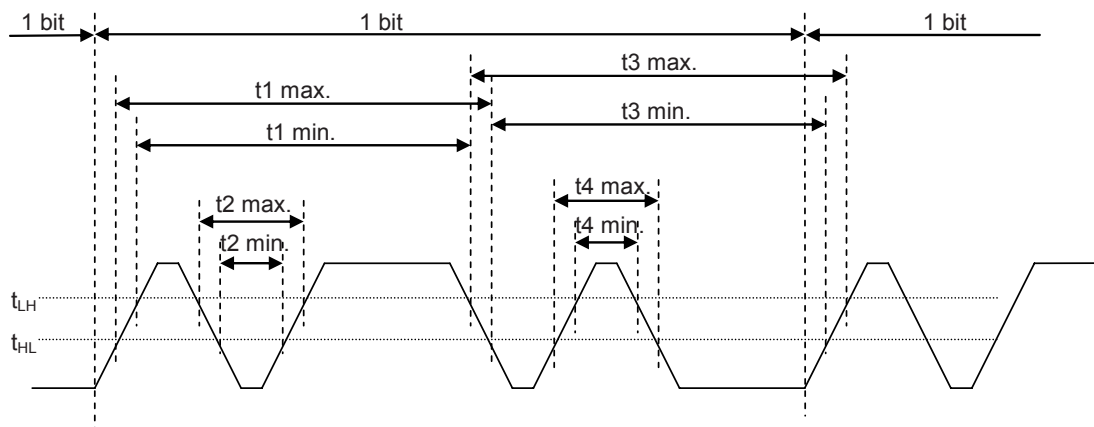

Figure 72 – Digital receive mask 3

Table 98 – Specifications for digital receive mask 3

Item	Restriction	Typical Value	Comment
$T1 \square t1_{max} - t1_{min} \square$	$7/8 [\text{mark}] + 0,5 \text{ ns} \leq T1 \leq 9/8 [\text{mark}] - 0,5 \text{ ns}$	1 [mark]	Real signal
$T2 \square t2_{max} - t2_{min} \square$	$T2 \leq 2/8 [\text{mark}] - 0,5 \text{ ns}$	1/8 [mark]	Noise
$T3 \square t3_{max} - t3_{min} \square$	$7/8 [\text{mark}] + 0,5 \text{ ns} \leq T3 \leq 9/8 [\text{mark}] - 0,5 \text{ ns}$	1 [mark]	Real signal
$T4 \square t4_{max} - t4_{min} \square$	$T4 \leq 2/8 [\text{mark}] - 0,5 \text{ ns}$	1/8 [mark]	Noise
NOTE This table applies to Figure 72 and the inversion of the signal pattern shown in Figure 72.			

5.7.6.3 Transmit processing requirements

The requirements for signals transmitted from the digital processing device are shown here. TXE refers to transmit enable, TXD refers to the data.

The transceiver timing shall conform to the timing and logic level of Figure 73 and Table 99.

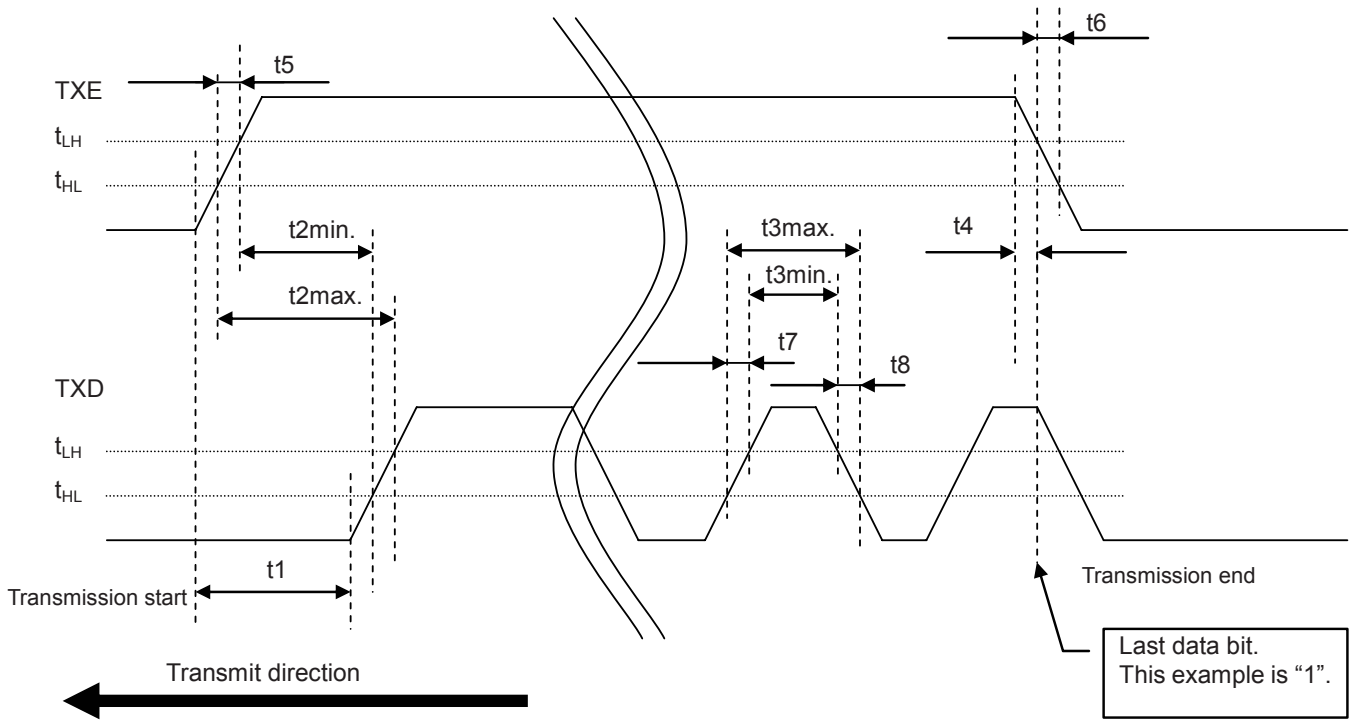

Figure 73 – Logical transmit mask

Table 99 – Specifications for logical transmit

Item	Restriction	Typical Value	Comment
t1	2 [mark] ± 0,25 ns	2 [mark]	TXE and TXD Load ≤ 15[pF]
T2 □t2max – t2min□	2 [mark] ± 2,0 ns	2 [mark]	TXE and TXD Load ≤ 15[pF]
T3 ^a □t3min – t3max□	X ^b [mark] ± 2,0 ns	X [mark]	TXE and TXD Load ≤ 15[pF]
t4	± 0,25 ns	0 ns	TXE and TXD Load ≤ 15[pF]
t5 Maximum period	1,9 ns	-	TXE Load ≤ 15[pF]
t6 Maximum period	1,9 ns	-	TXE Load ≤ 15[pF]
t7 Maximum period	1,9 ns	-	TXD Load ≤ 15[pF]
t8 Maximum period	1,9 ns	-	TXD Load ≤ 15[pF]
^a The timing applies also to the inverse pattern.			
^b X = {1, 2, 3}.			

5.7.7 Recommended circuits and component parameters

5.7.7.1 Recommended circuits

This subclause describes an example implementation as shown in Figure 74 and Figure 75.

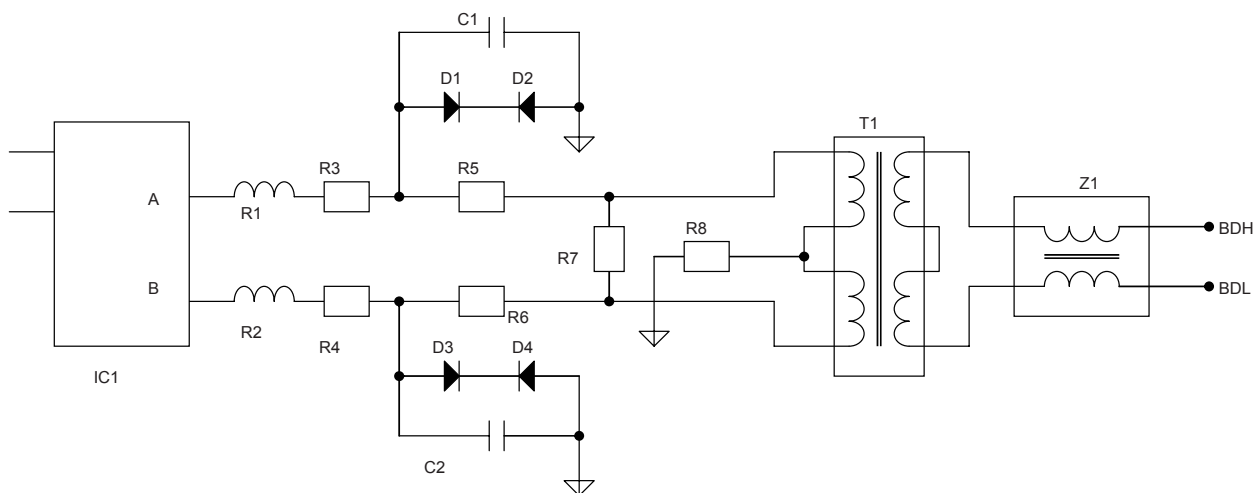

Components

C1	capacitor = 220 ± 11 pF rated voltage 16 V
C2	capacitor = 220 ± 11 pF rated voltage 16 V
D1	range of zener voltage is 5,84 V to 6,14 V
D2	range of zener voltage is 5,84 V to 6,14 V
D3	range of zener voltage is 5,84 V to 6,14 V
D4	range of zener voltage is 5,84 V to 6,14 V
IC1	transceiver
R1	ferrite beads
R2	ferrite beads
R3	register $R = 10 \pm 0,1 \Omega$
R4	register $R = 10 \pm 0,1 \Omega$
R5	register $R = 10 \pm 0,1 \Omega$
R6	register $R = 10 \pm 0,1 \Omega$
R7	register $R = 150 \pm 1,5 \Omega$
R8	register $R = 15 \pm 0,15 \Omega$
T1	pulse transformer
Z1	filter

Figure 74 – Recommended circuit for a master port

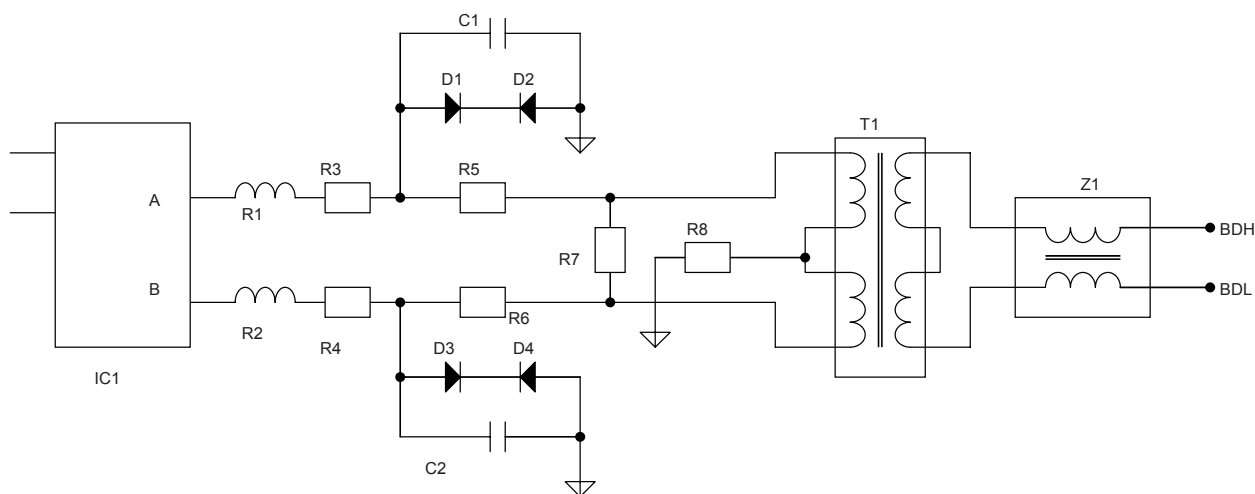

Components

C1	capacitor = $47 \pm 2,35$ pF rated voltage 16 V
C2	capacitor = $47 \pm 2,35$ pF rated voltage 16 V
D1	range of zener voltage is 5,84 V to 6,14 V
D2	range of zener voltage is 5,84 V to 6,14 V
D3	range of zener voltage is 5,84 V to 6,14 V
D4	range of zener voltage is 5,84 V to 6,14 V
IC1	transceiver
R1	ferrite beads
R2	ferrite beads
R3	register $R = 15 \pm 0,15 \Omega$
R4	register $R = 15 \pm 0,15 \Omega$
R5	register $R = 15 \pm 0,15 \Omega$
R6	register $R = 15 \pm 0,15 \Omega$
R7	register $R = 1\ 000 \pm 10 \Omega$
R8	register $R = 22 \pm 0,22 \Omega$
T1	pulse transformer
Z1	filter

Figure 75 – Recommended circuit for a slave port

5.7.7.2 Transformer specifications

5.7.7.2.1 General

An example of implementation for a transformer is shown in Figure 76 and Table 100.

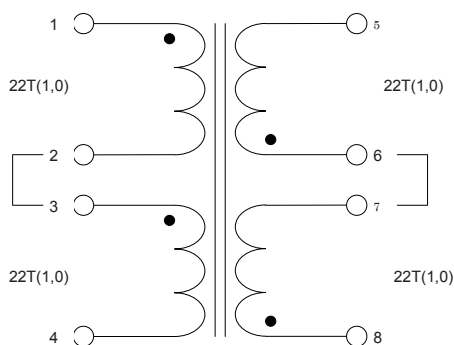

Figure 76 – Transformer symbol

Table 100 – Specification for pulse transformer

Specification	Characteristics
Operating ambient temperature	–10 °C to 85 °C
Operating ambient humidity	25 % to 95 %
Pulse frequency	23,4 kHz to 4 MHz
Minimum Inductance	6,5 mH at 10 kHz and 0,1 V, short-circuit between 2 and 3(1-2-3-4)
Transformation ratio	(3-4)/(1-2) 1,0 ± 0,02 (6-5)/(1-2) 1,0 ± 0,02 (8-7)/(1-2) 1,0 ± 0,02
Minimum open impedance(1-2-3-4)	Short-circuit between 2 and 3, 7 and 6 23,4 kHz to 31,25 kHz 0,8 kΩ at 0,1 V 31,25 kHz to 93,4 kHz 1,2 kΩ at 0,1 V 93,4 kHz to 3 MHz 3 kΩ at 0,1 V 3 MHz to 4 MHz 2 kΩ at 0,1 V
Maximum leakage inductance (1-2-3-4)	1,5 μH at 1 MHz and 0,1 V (8-7-6-5)
Maximum distributed capacity (1-2-3-4)	17 pF at 1 MHz and 0,1 V (6-7)
Maximum winding capacitance	55 pF at 10 MHz and 0,1 V (1-2-3-4)-(8-7-6-5)
Withstand voltage	500 V a.c. for 1 min and 600 V a.c. for 1 s Primary winding, secondary winding and core
Minimum Insulation resistance	500 V d.c. 100 MΩ Primary winding, secondary winding and core
Core	See 5.7.7.2 Core specifications
Wire	Solderable polyester copper wire
Wire gauge	AWG 38

5.7.7.2.2 Core specifications

An example of implementation for a transformer core is shown in Table 101.

Table 101 – Specifications for transformer core

Parameter	Symbol	Specification value
Initial permeability	μ_i	10 000 ± 3 000
Maximum relative loss factor	$\tan\delta/\mu_i$	$7,0 \times 10^{-6}$ at 10 kHz
Temperature factor of initial permeability	$\alpha_{\mu ir}$	$-0,5 \times 10^{-6}$ to $+1,5 \times 10^{-6}$ at -30 °C to +70 °C
Saturation magnetic flux density [H=1 194A/m]	B_s	400 mT at 25 °C nominal
Remanent flux density	B_r	90 mT at 25 °C nominal
Coercive force	H_c	7,2 A/m at 25 °C nominal
Minimum Curie temperature	T_c	120 °C
Maximum hysteresis material constant	η_B	$1,4 \times 10^{-6}/\text{mT}$
Maximum disaccommodation factor	DF	2×10^{-3}
Density	ρ_B	$4,9 \times 10^3 \text{ kg/m}^3$ nominal
Electrical resistivity	ρ_v	0,15 m nominal

5.7.7.3 Transceiver specifications

CompoNet shall use transceivers that support TIA/EIA-485-A [4].The transceivers shall also conform to the specification shown in Table 102. Table 103 and Table 104 provide additional requirements for sending and receiving.

Table 102 – Specifications for transceiver

Specification	Minimum	Typical	Maximum
Driver differential output voltage, VOD (R = 27 Ω (RS-485)); See Figure 77.	1,5 V	-	5,0 V
Common-mode output voltage , VOC(R = 27 Ω or 50 Ω)	-	-	3 V
Output short circuit current (-7 V ≤ VO ≤ +12 V)	-	-	250 mA
Propagation delay Input to output TPLH, TPHL (RL Diff = 54 Ω, CL1 = CL2 = 100 pF); See Figure 78.	2 ns	10 ns	15 ns
Driver O/P to O/P TSKEW (RL Diff = 54 Ω,CL1 = CL2 = 100 pF)	0 ns	0 ns	5 ns
Driver rise/fall time TR, TF (RL Diff = 54 Ω, CL1 = CL2 = 100 pF)	-	2 ns	10 ns
Driver enable to output valid	-	10 ns	25 ns
Driver disable timing	-	10 ns	25 ns
Receiver differential input threshold voltage, VTH minimum	-0,05 V	-	+0,05 V
Input voltage hysteresis, Δ VTH	50 mV	-	100 mV
Input resistance	12 kΩ	-	-
Logic enable input current (RE)	-1 μA		+1 μA
Short circuit output current (VOOUT = GND or VCC)	7 mA	-	85 mA
Propagation delay input to output TPLH, TPHL(CL = 15 pF)	18 ns	25 ns	40 ns
Maximum skew TPLH–TPHL	-	0 ns	5 ns
Operating temperature	-40 °C	-	+85 °C
Maximum absolute Vdc	-	-	7 V

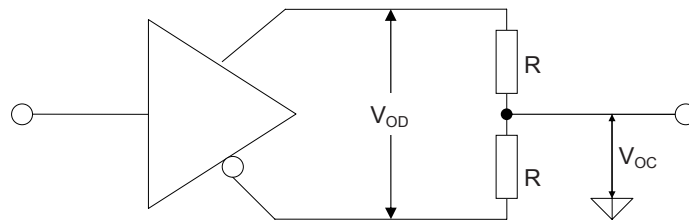

Figure 77 – Driver voltage measurement circuit

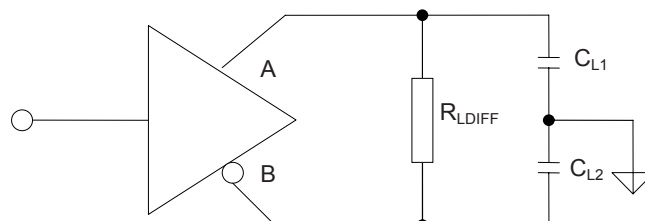

Figure 78 – Propagation delay test circuit

Table 103 – Sending

INPUTS			OUTPUT	
RE	DE	DI	B	A
X	1	1	0	1
X	1	0	1	0
X	0	X	Z	Z

Table 104 – Receiving

INPUTS			OUTPUT
RE	DE	A-B	RO
0	0	$\geq +0,05$	1
0	0	$\leq -0,05$	0
0	0	Inputs Open	1
1	0	X	Z

5.7.8 Isolation

Master and slave ports shall be transformer coupled to the network.

The communication port shall be isolated from the application and earth on chassis grounds with a minimum isolation to the communication lines of 500 V a.c. RMS 47 Hz to 63 Hz for 60 s.

In the case of a simple slave, isolation from network power may be met through installation.

In the case of an auxiliary power supply connection, isolation shall be provided between the network port including the network power supply and the auxiliary power supply.

For a non-network powered slave, the external power supply shall provide isolation from the power as shown in Table 111 and Table 112.

Several examples of implementation diagrams are shown in Figure 79, Figure 80, Figure 81 and Figure 82.

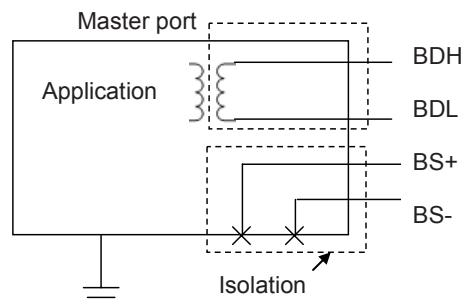

Figure 79 – An isolation example of a master port

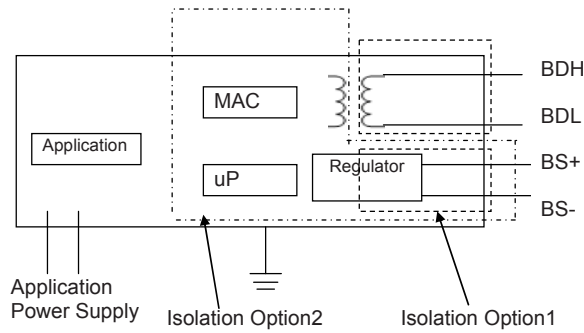

Figure 80 – An isolation example of an I/O module with connectivity to other power sources

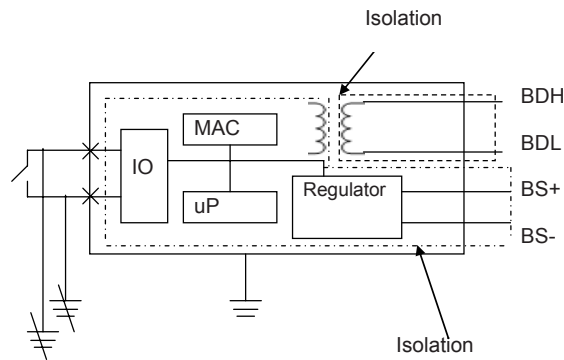

Figure 81 – An isolation example of a simple slave that requires connection to devices with ungrounded signal wiring

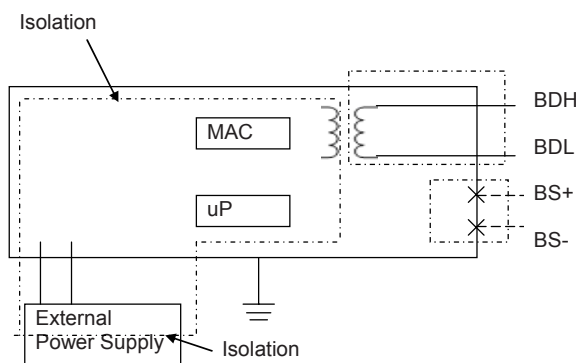

Figure 82 – An isolation example of a non-network powered slave

5.7.9 Transmission medium

The following cables shown in Table 105 are supported. Only one type of cable shall be used in a segment.

Table 105 – Cable types

Cable type	Specification	Allowable current
CompoNet round cable I	2-conductor round cable. See profile 8.2.3	N/A
CompoNet round cable II	4-conductor round cable. See profile 8.2.4	Up to 4 A
CompoNet flat cable I	4-conductor flat cable. See profile 8.2.5	5 A
CompoNet flat cable II	4-conductor flat cable. See profile 8.2.6	5 A

Each type of cables shall conform to the signals and colour as defined in Table 106.

Table 106 – Cable conductor colours

Signal name	CompoNet round cable I	CompoNet round cable II	CompoNet flat cables
BS+	-	Red	Red
BDH	White	White	White
BDL	Black	Blue or green	Blue
BS-	-	Black	Black

5.7.10 Topology

5.7.10.1 General

CompoNet supports multi-drop and T-branch topology. The cable distance between any two points in the cable system shall not exceed the maximum cable distance allowed for the bit rate. Terminators are required on each end of the trunk line. CompoNet supports a multi-segment structure. One segment supports up to 32 slave/repeater nodes. A typical topology is shown in Figure 83.

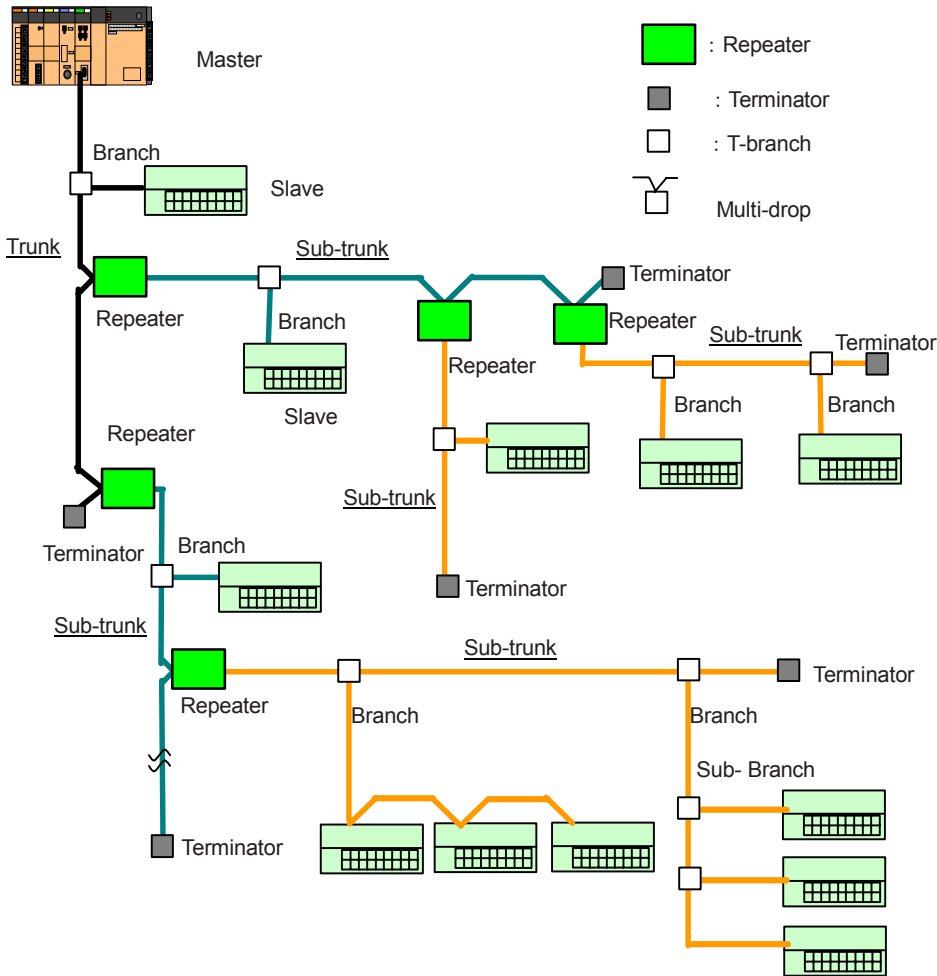

Figure 83 – Media topology

5.7.10.2 Segment

CompoNet usually consists of several segments separated by repeaters. Each segment is connected on the network, but is classified from the viewpoint of the physical layer. As shown in Figure 1, the segment that has the master is called the first segment layer. A second and third segment layer can be added using repeaters, but no more than 2 such extra segments can be added, thus assuring that no slave is more than 2 repeaters (or 3 segments) away from its master. A total of 64 repeaters can be used in one network. All segments shall operate at the same communication speed. A repeater shall set its master port to the speed of its slave port.

5.7.10.3 Placement of terminators in each segment

Terminators are located internally in the master ports of the master and repeaters. In addition to these internal resistors, a terminator shall be added to the network at the opposite end of the master port as shown at Figure 84.

The connection position of the master port depends on the network topology. For general wiring, master ports shall be at one end of a trunk or sub-trunk. For flexible wiring, master ports can be connected freely.

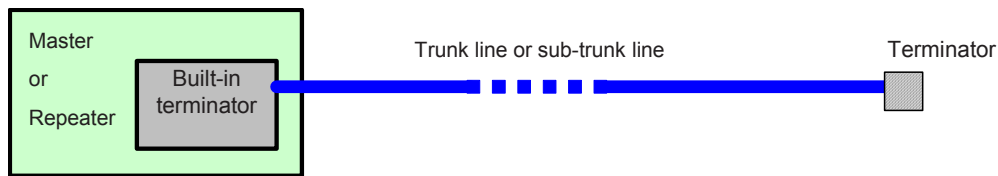

Figure 84 – Position of a terminator

5.7.10.4 Number of devices in one segment

One master port and 32 slave ports can be connected on each segment as shown in Figure 85. This includes slave ports on repeaters and slave ports on any T-branches which are part of the segment.

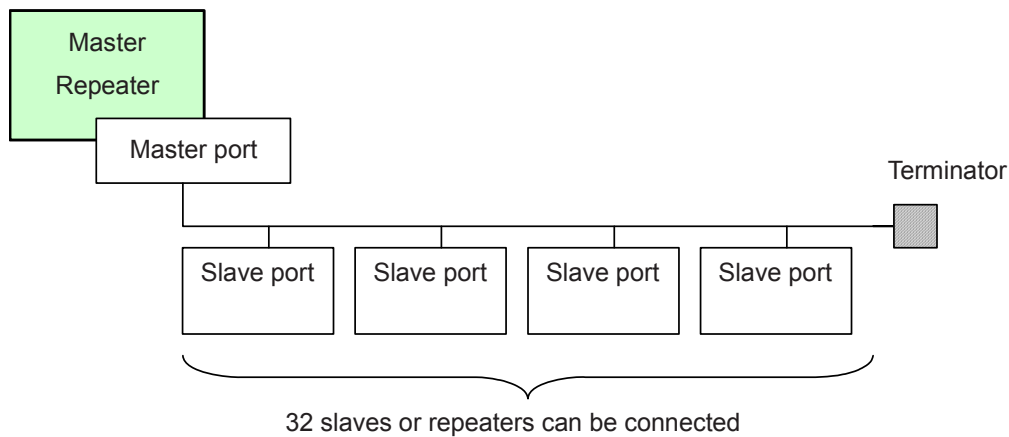

Figure 85 – Number of devices per segment

5.7.10.5 Cable type and cable length

The trunk line length, sub-trunk line length, maximum length of one branch line, total branch line length, and maximum number of devices are all dependant on the transmission speed. Table 107, Table 108 and Figure 86 define the limits based on transmission speed.

Figure 87 indicates branch restrictions which shall apply.

Table 107 – CompoNet round cable I: network limitations

Transmission speed kbit/s	Wiring pattern	Trunk line max. length m	Total number of slaves	Max. length of one branch line m	Total branch line length m	Number of slaves connected to one branch line	Max. sub-branch line length m	Total sub-branch line length m
4 000	General ^a	30	32	0	0	0	0	0
3 000	General	30	32	0,5	8	1	0	0
1 500	General	100	32	0	0	0	0	0
		30	32	2,5	25	3	0	0
93,75	General	500	32	6	120	1	0	0

^a See 5.7.10.6.2.

Table 108 – CompoNet 4-conductor cables: network limitations

Transmission speed kbit/s	Wiring pattern	Trunk line max. length m	Total number of Slaves	Max. length of one branch line m	Total branch line length m	Number of slaves connected to one branch line	Max. sub-branch line length m	Total sub-branch line length m
4 000	General	30	32	0	0	0	0	0
3 000	General	30	32	0,5	8	1	0	0
1 500	General	30	32	2,5	25	3	0,1	2
93,75	Flexible ^a	200	32	Flexible wiring is available if the total wiring length is 200 m or less.				

^a See 5.7.10.6.3.

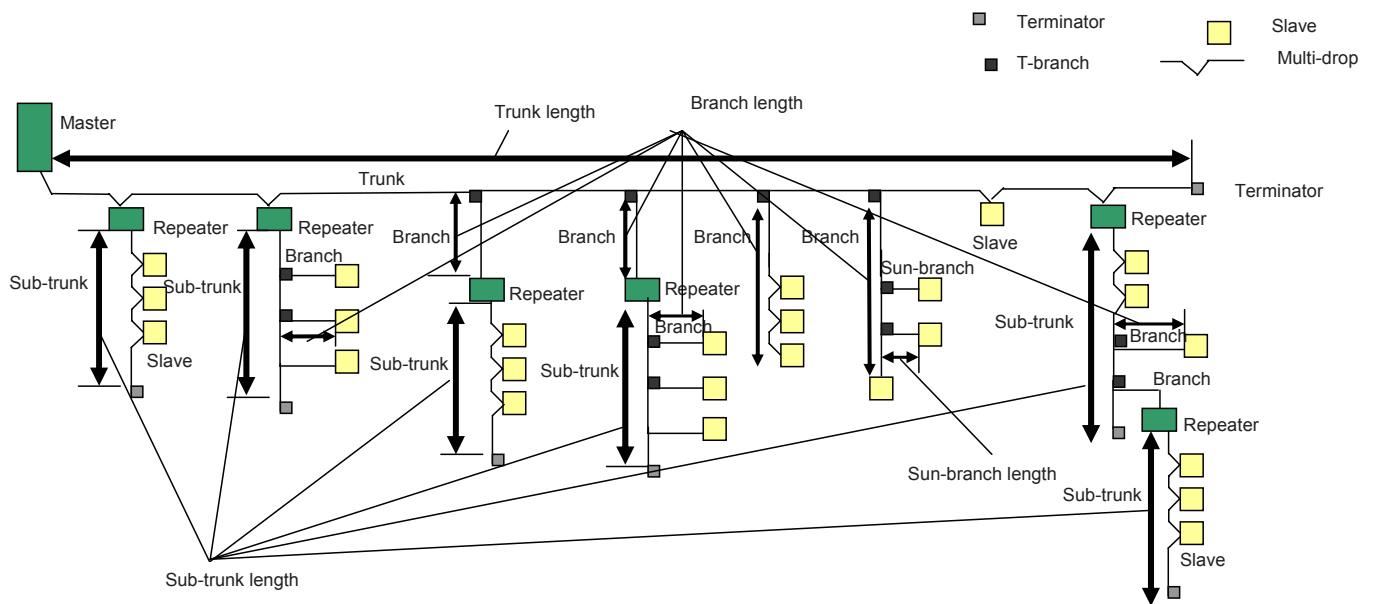

Figure 86 – Cable length limitation Illustration

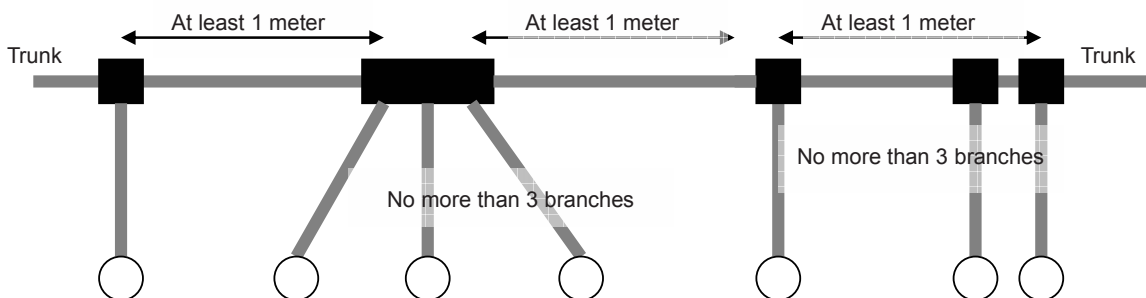

Figure 87 – Branch restriction

5.7.10.6 Wiring types in one segment

5.7.10.6.1 General

There are 2 types of wiring patterns in a segment: general wiring and flexible wiring.

As shown in Figure 88, CompoNet round cable I is only for general wiring, and can be used for all data rates. CompoNet 4-conductor cables support general wiring at 4 Mbit/s; 3 Mbit/s and 1,5 Mbit/s. At 93,75 kbit/s, the 4-conductor flat cables support flexible wiring.

At 93,75 kbit/s, there are the following design criteria:

- the trunk line length needs to support long distance communications (approximately 500 m for general wiring);
- restrictions on wiring method need to be reduced as much as possible (flexible wiring);
- for optimal use at 93,75 kbit/s, round cable I can be used for the general wiring method. Round cable II, Flat cable I and Flat cable II can be used for the flexible wiring method.

Dimension : kbit/s

Cable	Speed			
	4 000	3 000	1 500	93,75
CompoNet Round Cable I				
CompoNet 4-conductor Cables				

General
Flexible

Figure 88 – Wiring selection

5.7.10.6.2 General wiring

General wiring is illustrated in Figure 89.

The restrictions are:

- the master port shall be connected to one end of a trunk line or a sub-trunk line;
- only one master port is connected on one segment;
- a terminator is connected to the other end of the trunk line or sub-trunk line;
- a slave port can be connected to the trunk line or sub-trunk line via a multi-drop (daisy chain)
- a slave port can be connected to the trunk line or sub-trunk line via a branch.
- a slave port can be connected to a branch line via a sub-branch;
- the end of any communication line shall not be left open or unconnected. It shall be connected to a master port, a slave port or a terminator;
- L1>L2, L3>L4, L5>L6. See Figure 89.

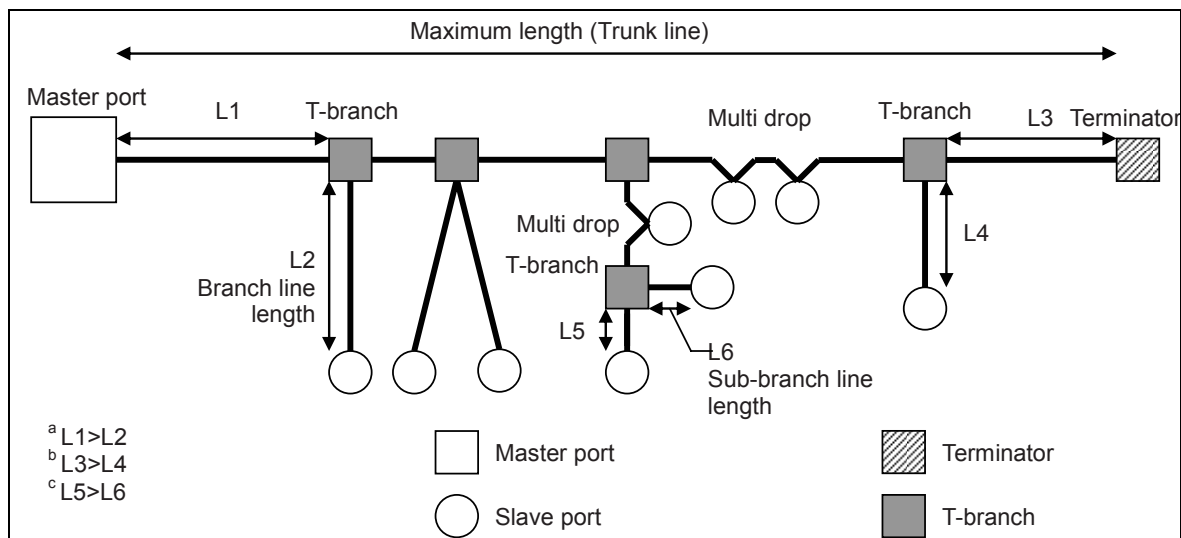

Figure 89 – General wiring method

5.7.10.6.3 Flexible wiring

Flexible wiring structures are supported only using CompoNet 4-conductor cables at speeds of 93,75 kbit/s. This wiring approach is suitable for applications where:

- many branches are needed;
- network lengths are short.

Flexible wiring is illustrated in Figure 90. The rules for flexible wiring are shown below:

- in flexible wiring, there is no distinction between trunk line and branch line;
- only one master port is connected on one segment;
- the master port may be placed anywhere in a segment (it does not have to be end connected);
- one terminator is connected to the farthest point from the master port (cable distance, not installed geographical distance);
- several branch points can be added to a branch;
- the length of all cables is counted within the specified total wiring length;
- the end of any cable shall not be left open (unconnected). It shall be connected to the master port, a slave port or a terminator.

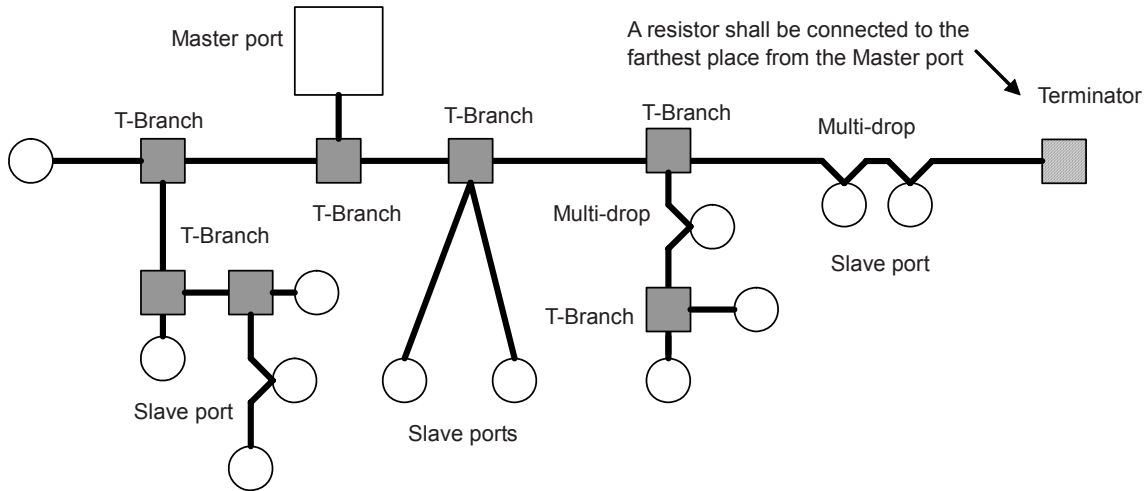

Figure 90 – Flexible wiring method

5.7.10.7 Network terminator

A terminator shall be mounted on the farthest end of the trunk line from the master device or master ports of repeaters. The terminator is defined by Table 109.

Table 109 – Resistance characteristics

Item	Characteristic
Rated power	1/4 W
Resistance	121 Ω
Maximum accuracy	1 %
Metal Film	

5.7.11 Link power

5.7.11.1 CompoNet power supply

5.7.11.1.1 Specification for network power supply at the master port

Network power supply is provided only by a master port. Mid span power insertion is not supported. The network power supply shall comply with Table 110.

This is the case shown in Figure 79

Table 110 – Network power supply specifications

Specification	Parameter
Output voltage	24 ± 2,4 V d.c.
Maximum output ripple	600 mV _{peak to peak}
Temperature range	Specified by vender
Over voltage protection	Yes (no value specified)
Over current protection	Yes (continuous current: limit 5 A max)
Maximum turn-on overshoot	5 %
Output current	Up to 5 A continuous
Isolation (based on IEC 61131-2□)	2,3 kV a.c.

5.7.11.1.2 Specification for local power supply at slave ports

The local power supply connected to slave ports shall comply with Table 111.

Table 111 – Local power supply specifications

specification	Parameter
Output voltage	14 V d.c. to 26,4 V d.c.
Maximum output ripple	600 mV _{peak to peak}
Temperature range	Specified by vender
Over voltage protection	Yes (no value specified)
Over current protection	Yes
Maximum turn-on overshoot	5 %
Isolation (based on IEC 61131-2□)	2,3 kV a.c.

5.7.11.1.3 Specification for external power supply at the node

When nodes are powered by external power supplies, the requirements are shown in Table 112.

Table 112 – Node external power supply specifications

Specification	Parameter
Isolation	2,3 kV a.c. (based on IEC 61131-2□)

5.7.11.2 Power dispatching method

5.7.11.2.1 General

This subclause describes how to power the network when using 4-conductor cable. For networks using 2-conductor cable, each device requires local network power and this clause is not applicable.

The power dispatching method is shown by Figure 91.

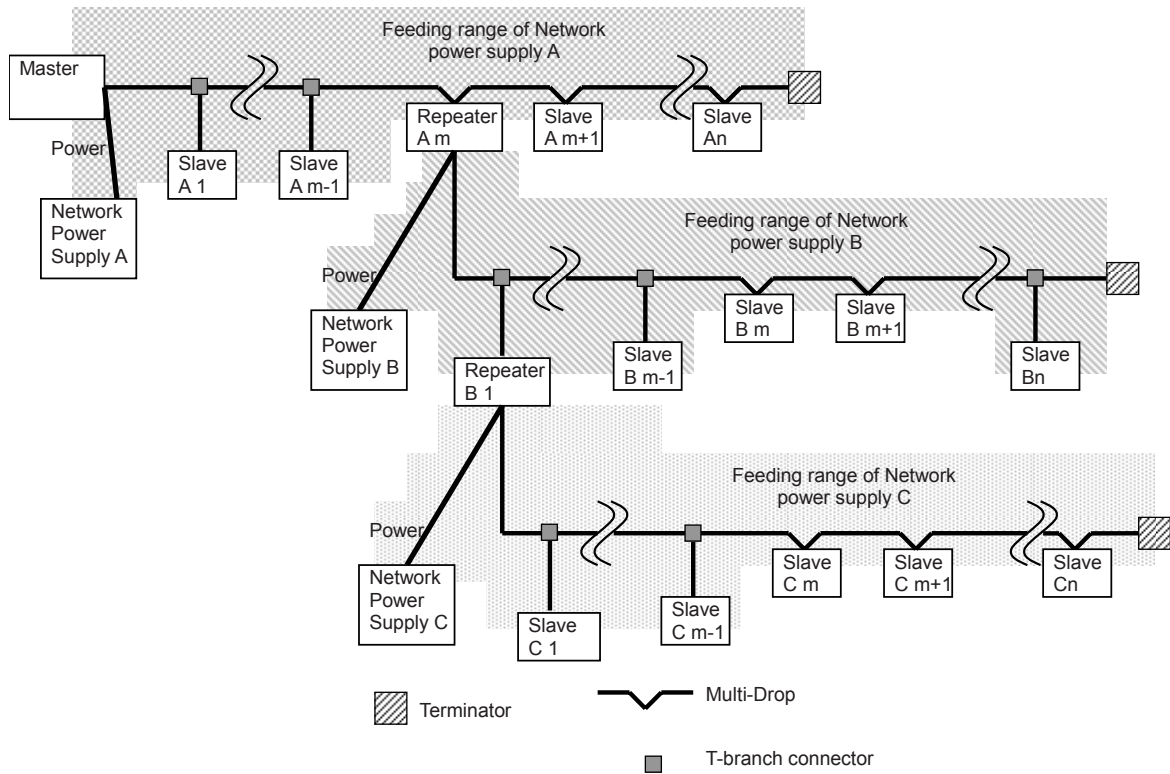

Figure 91 – Power dispatching method

5.7.11.2.2 Powering the network by a power supply connected to the master

When the network is powered via master as shown by Figure 92 and Figure 93, the power cable between the master and the power supply shall be no greater than 3 m.

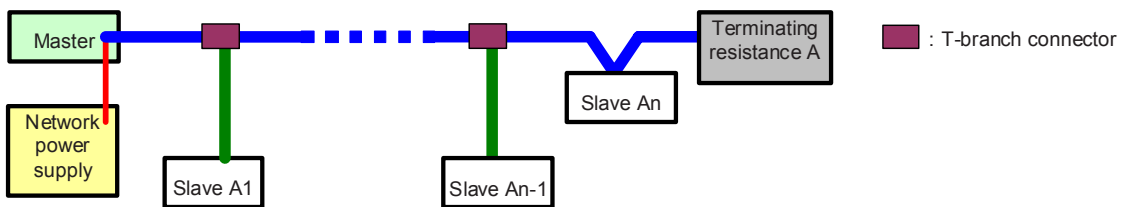

Figure 92 – Network segment powered by the master

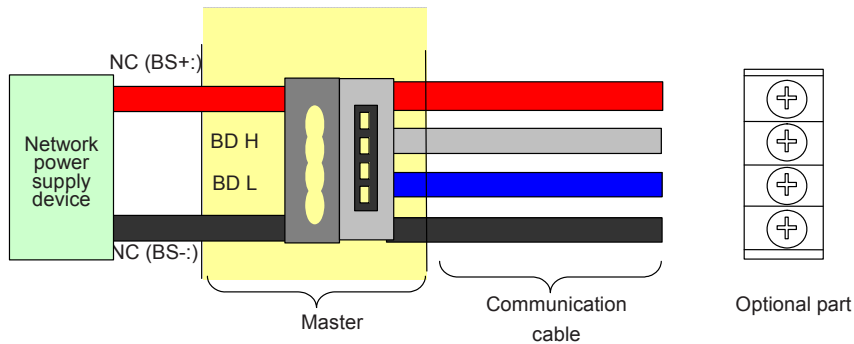

Figure 93 – Connection with power supply

Figure 93 shows two approaches to providing power. An adapter can provide coupling between the cable connector from the power supply to the cable connector on the communication cable. Alternatively the “Optional part” shown can be a single connector attached to both power and line cables and plugged into the the master.

5.7.11.2.3 Powering the network by a power supply connected to a repeater

The master port of a repeater may power its sub-network using an external power supply and subject to the same restriction that the line between the master port and the power supply shall not be greater than 3 m, as shown by Figure 94.

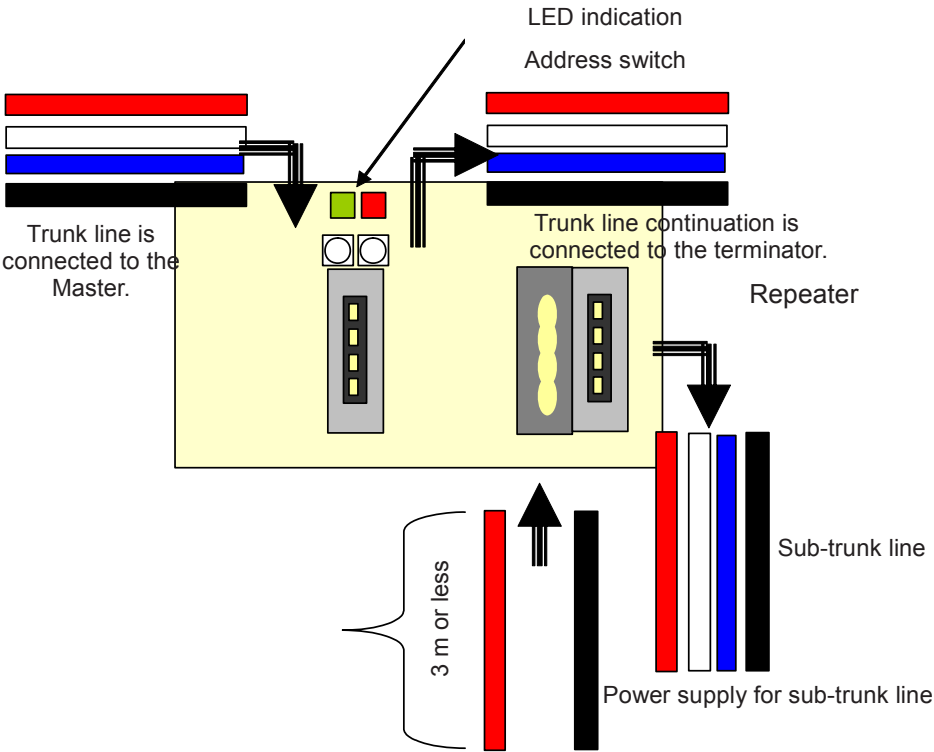

Figure 94 – Network segments powered by repeaters

Powering range of repeater Am:

- network power supply A is connected to the power supply connector of the master to power units from slave A1 to An, and repeater Am;
- network power supply B is used to power repeater Bm and slave B1 to Bn on the sub-trunk line connected after repeater Am.

Powering range of repeater Bm:

- network power supply C is used to feed Slave C1 to Cn on the branch line connected after repeater Bm;
- network power supply C is connected to the terminal BS+C/BS-C of repeater Bm.

5.7.12 Repeater implementation

A repeater shall consist of:

- a slave port as defined in 5.7.4,
- a master port as defined in 5.7.3,

- a built-in power supply or an external power supply port. For an external port, the connector shall conform to 5.7.11.1.1, and
- an addressable MAC conformant to 5.7.6.

The propagation delay requirements are defined in 5.6.2.4.

A simplified block diagram is shown as Figure 95.

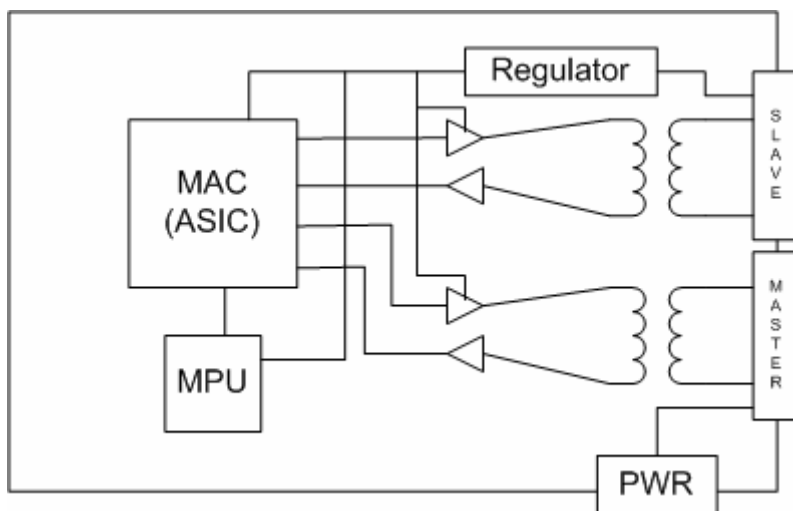

Figure 95 – A simplified diagram for a repeater

Power shall be provided to the downstream slaves from the master port of a repeater using the same methods that are specified for the master port of a master. In all cases the power at the master port shall conform to 5.7.11.1.1.

Power at the repeater slave port shall be isolated from the repeater master port power source.

The network supply at the slave port side shall be isolated from the power supply for the master port.

6 Product information

In accordance with IEC 62026-1.

7 Normal service, mounting and transport conditions

7.1 Normal service conditions

7.1.1 General

Components of a CompoNet CDI shall be capable of operating under the following conditions.

If the conditions for operation differ from those given in this part, the user shall state the deviation from the standard conditions and consult the manufacturer on the suitability for use under such conditions.

7.1.2 Ambient air temperature

7.1.2.1 Round cable I

The cable shall operate normally within an ambient temperature range of -10 °C to 60 °C.

7.1.2.2 Round cable II, flat cable I, flat cable II

The cable shall operate normally within an ambient temperature range of -10 °C to 55 °C.

7.1.2.3 Other CDI components

All other components of the CDI shall operate between the ambient temperatures of -5 °C to +40 °C if not otherwise defined, for example in conjunction with a specific actuator or sensor type. The operating characteristics shall be maintained over the permissible range of ambient temperature.

7.1.3 Altitude

Components shall be capable of operating at altitudes in accordance with IEC 62026-1.

7.1.4 Climatic conditions

7.1.4.1 Humidity

Components shall be capable of operating at 40 °C, with the relative humidity of the air not exceeding 85 %.

7.1.4.2 Pollution degree

Components shall be capable of operating in polluted conditions in accordance with IEC 62026-1.

7.2 Conditions during transport and storage

A special agreement shall be made between the user and manufacturers if the conditions during transport and storage, for example temperature and humidity conditions, differ from those defined in 7.1.

7.3 Mounting

Components shall be mounted in accordance with IEC 62026-1.

8 Constructional and performance requirements

8.1 Indicators and configuration switches

8.1.1 Status indicators

8.1.1.1 General

Devices may have one module status indicator and one CDI status indicator. If they are included, they shall comply with these requirements and shall also be clearly distinguishable from any other indicators.

8.1.1.2 Module status indicator

Module status shall be shown by a bicolour (green/red) indicator to indicate whether or not the circuitry is powered and operating correctly. The indicator states shall be as specified in Table 113.

Table 113 – Module status indicator

Indicator status	Meaning
Off	Not powered
Green	Operating correctly
Flashing Green	In standby
Flashing Red	Recoverable fault
Red	Unrecoverable fault
Flashing Red-Green	Undergoing self-test
NOTE Indicator flash rates are given in 8.1.1.5.	

8.1.1.3 CDI status indicator

This shall be a bicolour (green/red) indicator and shall indicate the status of the communication link as specified in Table 114.

Table 114 – CDI status indicator

Indicator status	Meaning
Off	The circuitry is not powered, or device is in speed detection.
Flashing Green	Device knows data rate but is not participated. If device is slave, waiting for STW and allocate. If device is repeater, Waiting for STW.
Green	Device is participated. If device is slave, allocated and I/O connection established. If device is repeater, repeating.
Flashing Red	Device knows timeout, or device is in speed detection with timeout.
Red	Device is in communication fault with the duplicate MAC ID detection.
Flashing Red-Green	Device is in self-test.
NOTE Indicator flash rates are given in 8.1.1.5.	

8.1.1.4 Module and CDI status indicators at power-up

The following indicator test sequence shall be performed at power-up:

- CDI status indicator OFF;
- module status indicator ON green for $0,25\text{ s} \pm 0,1\text{ s}$;
- module status indicator ON red for $0,25\text{ s} \pm 0,1\text{ s}$;
- module status indicator ON green;
- CDI status indicator ON green for $0,25\text{ s} \pm 0,1\text{ s}$;
- CDI status indicator ON red for $0,25\text{ s} \pm 0,1\text{ s}$;
- CDI status indicator OFF;
- both indicators assume states according to Table 113 and Table 114.

8.1.1.5 Indicator flash rate

Unless otherwise specified in this part, the flash rate of an indicator shall be 1 flash per second $\pm 0,5\text{ s}$. An indicator shall be ON for $0,5\text{ s} \pm 0,25\text{ s}$ and OFF for $0,5\text{ s} \pm 0,25\text{ s}$.

8.1.2 Switches

8.1.2.1 General

Devices may be fitted with switches, depending on the device type.

- master devices may have data rate switches.
- slave and repeater devices may have node address switches.

8.1.2.2 Data rate switches

If switches are used to set data rate, they shall be encoded as shown in Table 115.

Table 115 – Data rate switch encoding

Bit rate (bit/s)	Switch setting
4 M	0
3 M	1
1,5 M	2
93,75 k	3

A slave or repeater shall not have a data rate switch.

8.1.2.3 Node addresses switches

Node addresses switches and the set values depend on the device switch type.

If DIP switches are used;

- they shall be in binary format.
- the orientation of greatest to least significant bits shall be from left to right or top to bottom.
- unless otherwise labelled, the on position shall be the top or right position.

If rotary or push wheel switches are used;

- they shall be in decimal format.
- the more significant digit is always to the left or to the top.

8.1.2.4 Device type, node address switches and their setup range

Table 116 summarizes the node address switches and their set range for different device types.

Table 116 – Addresses switches

Device type	Address switches
Word slave	Setting range from 0 to 63. Binary format or decimal format. Addresses larger than 63 cannot participate in the communication.
Bit slave	Setting range from 0 to 127. Binary format or decimal format. Addresses larger than 127 cannot participate in the communication.
Repeater	Setting range from 0 to 63. Binary format or decimal format. Addresses larger than 63 cannot participate in the communication.

8.1.3 CompoNet marking

8.1.3.1 General

This subclause includes specifications of the following markings:

- indicators;
- switches and device types;
- connectors.

8.1.3.2 Indicator marking

Indicators shall be marked with either their full names or their abbreviated names, as specified in Table 117.

Table 117 – Indicator marking



Description	Full name	Abbreviated name
Module status indicator	Module status	MS
CDI status indicator	Network status	NS

8.1.3.3 Node address switch and device type marking

Node address switches and device types shall be marked with either their full names or their abbreviated names, as specified in Table 118.

Table 118 – Node address switch and device type marking

Device type		Marking specification	Device marking appearance	Switch marking
Word slave	IN	Label: IN Color: Orange Color code: 2,5YR/6/13 Font size: Min. heights 1,5 mm	IN	One of the following: NODE ADDRESS NA WORD NODE ADDRESS WORD NODE ADR
	OUT	Label: OUT Color: Yellow Color code: 2,5Y8/14 Font size: Min. heights 1,5 mm	OUT	
	MIX	Label: IN Color: Orange Color code: 2,5YR/6/13 Label: OUT Color: Yellow Color code: 2,5Y8/14 Font size: Min. heights 1,5 mm	IN OUT	
Bit slave	IN	Label: BIT IN Color: Orange Color code: 2,5YR/6/13 Font size: Min. heights 1,5 mm	BIT IN	One of the following: NODE ADDRESS NA BIT NODE ADDRESS BIT NODE ADR
	OUT	Label: BIT OUT	BIT OUT	

Device type		Marking specification	Device marking appearance	Switch marking
		Color: Yellow Color code: 2,5Y8/14 Font size: Min. heights 1,5 mm		
	MIX	Label: BIT IN Color: Orange Color code: 2,5YR/6/13 Label: BIT OUT Color: Yellow Color code: 2,5Y8/14 Font size: Min. heights 1,5 mm	 	
Repeater		Label: RPT Color: Green Color code: 10GY6/10 Font size: Min. heights 1,5 mm		One of the following: NODE ADDRESS NA RPT NODE ADDRESS RPT NODE ADR

The labels may be black and white. However, if colored labels are used, then the colors specified above shall be used.

Label text shown above is for devices that use only one node address. For devices that use multiple node addresses, the label text shall include “xN” immediately following the above text. “N” represents the number of addresses used. For example, for an IN device that uses two addresses, the label shows “IN x2”. If the number of addresses used by a node is variable depending on user configuration (e.g. a modular I/O block), then the label would show “IN x__”.

8.1.3.4 Connector marking

Connectors may include markings to identify their pin and cable assignment using either their full names or their color, as specified in Table 119.

Table 119 – Connector marking

Signal name	Pin No.	Open connector	Flat connector I
BS+	1	BS+	Red
BDH	2	BDH	White
BDL	3	BDL	Blue
BS□	4	BS□	Black

8.2 CompoNet cable

8.2.1 Overview

This subclause includes specifications of following cable profiles:

- round cable I;
- round cable II;
- flat cable I;

- flat cable II.

8.2.2 Cable profile template

A cable profile defines the data pair specifications, d.c. power pair specifications, general specifications, topology and the physical configuration for the cable. The orientation of the data and power pairs is a requirement of the specification. Table 120, Table 121, Table 122 and Table 29 define the minimum fields that shall be defined for a cable profile.

Table 120 – Cable profile: data pair specification

Physical characteristics	Specification
Conductor pair size	<size> <material>; <#> strands
Insulation diameter	<size>
Colors – (BDH, BDL)	
Pair twist	<#> / <distance>
Tape shield over pair	<material>
Electrical characteristics	Specification
Impedance	82 Ω to 115 Ω (at 1 MHz, for 2-conductor cable) 95 Ω to 132 Ω (at 1 MHz, for 4-conductor cable)
Maximum propagation delay	6,5 ns/ <distance>
Maximum capacitance between conductors	<#> pF/ <distance> at 100 kHz
Maximum capacitance between one conductor and other conductor connected to shield.	<#> pF/ <distance> at <#> Hz
Maximum capacitive unbalance	<#> pF/ <distance> at <#> kHz ASTM D4566
Maximum DCR - at 20 °C	<#> Ω /1 000 m <distance>
Maximum attenuation:	<#> dB/<distance> at 8 MHz <#> dB/<distance> at 6 MHz <#> dB/<distance> at 4 MHz <#> dB/<distance> at 3 MHz <#> dB/<distance> at 93,75 kHz

Table 121 – Cable profile: d.c. power pair specification

Physical characteristics	Specification
Conductor pair size	<#> <material>; <#> strands
Insulation diameter	<#>
Colors - (BS+, BS-)	
Pair twist	<#>/ <distance>
Tape shield over pair	<material>
Electrical characteristics	Specification
Maximum DCR - at 20 °C	<#> Ω /1 000 m

Table 122 – Cable profile: general specification

Physical characteristics	Specification
Geometry	
Overall braid shield	<#> % coverage, <#> <material>
Drain wire	<#> <material>; <#> strands
Outside diameter	<size> minimum to <size> maximum
Roundness	Radius delta to be <#> % of O.D.
Jacket marking	Vendor name, part # and additional markings
Electrical characteristics	Specification
Maximum DCR – (braid+tape+drain) at 20 °C	<#> Ω/ <distance>
Applicable environmental characteristics	Specification
Agency certifications	
Flexure	<#> cycles at bend radius, <#> degrees, <#> pull force, <#> cycles/minute, <method>
Bend radius	<#> × diameter (installation) / <#> × diameter (fixed) <method>
Operating ambient temperature	<#> °C to <#> °C
Storage temperature	<#> °C to <#> °C
Minimum pull tension	<#> kg
Connector compatibility	<Open, Flat, M12.....,>
Topology compatibility	<Trunk, Drop, ...>
Unique characteristics	Application specific

8.2.3 Round cable I profile

The following specifications apply to round cable I:

- data pair specifications, see Table 123;
- power pair specifications, see Table 124;
- general specifications, see Table 125.

Table 123 – Round cable I: data pair specification

Physical characteristics	Specification
Conductor pair size	0,75 mm ² ±0,075 mm ² or 18 AWG, Cu (Sn plating), Minimum strands is 17 strands. Maximum twist pitch is 1 twist / 50 mm.
Insulation diameter	2,3 mm ±0,23 mm
Colors – (BDH, BDL)	BDH: white, BDL: blue (preferred) or black (optional)
Pair twist	Maximum twist pitch is 1 twist / 92 mm.
Tape shield over pair	N/A
Electrical characteristics	Specification
Impedance	97 Ω ±14,55 Ω (at 1 MHz)
Maximum propagation delay	6,5 ns/m (6 MHz to 40 MHz, 20 °C)
Maximum capacitance between conductors	100 pF/m (at 100 kHz, 20 °C)
Maximum capacitance between one conductor and other conductor connected to shield	N/A
Capacitive unbalance	N/A
Maximum DCR - at 20 °C	25,1 Ω / 1 000 m
Maximum attenuation:	116 dB / 1 000 m at 8 MHz 88 dB / 1 000 m at 6 MHz 60 dB / 1 000 m at 4 MHz 45 dB / 1 000 m at 3 MHz 4,6 dB / 1 000 m at 93,75 kHz

Table 124 – Round cable I: d.c. power pair specification

Physical characteristics	Specification
Conductor pair size	N/A
Insulation diameter	N/A
Colors – (BS+, BS-)	N/A
Pair twist	N/A
Tape shield over pair	N/A
Electrical characteristics	Specification
Maximum DCR - at 20 °C	N/A

Table 125 – Round cable I: general specification

Physical characteristics	Specification
Geometry	One twisted pair
Over braid shield	N/A
Drain wire	N/A
Outside diameter	About 6,6 mm
Roundness	90 % to 110 %
Jacket marking	Vendor name, part number and additional markings
Electrical characteristics	Specification
Maximum DCR – (braid+tape+drain) at 20 °C	N/A
Applicable environmental characteristics	Specification
Agency certification	N/A
Flexure	Specified by vendor
Bend radius	Specified by vendor
Operating ambient temperature	-10 °C to +60 °C
Storage temperature	-20 °C to +65 °C
Minimum pull tension	29,48 kg maximum
Connector compatibility	Open connector
Topology compatibility	Trunk, branch

8.2.4 Round cable II profile

The following specifications apply to round cable II:

- data pair specifications, see Table 126;
- power pair specifications, see Table 127;
- general specifications, see Table 128;
- physical configuration, see Figure 96.

Table 126 – Round cable II: data pair specification

Physical characteristics	Specification
Conductor pair size	0,75 mm ² ±0,075 mm ² or 18 AWG maximum, Cu (Sn plating), Minimum strands is 17 strands. Maximum twist pitch is 1 twist / 50 mm
Insulation diameter	2,3 mm ±0,23 mm
Colors – (BDH, BDL)	BDH: white, BDL: blue (preferred) or green (optional)
Pair twist	None
Tape shield over pair	None
Electrical characteristics	Specification
Impedance	120 Ω -18 Ω to 120 Ω+12 Ω (at 1 MHz)
Maximum propagation delay	6,5 ns/m (6 MHz to 40 MHz, 20 °C)
Maximum capacitance between conductors	73 pF/m (at 100 kHz, 20 °C)
Maximum capacitance between one conductor and other conductor connected to shield	N/A
Maximum capacitive unbalance	7 260 pF / 1 000 m, at 100 kHz
Maximum DCR - at 20 °C	25,1 Ω / 1 000 m
Maximum attenuation	116 dB / 1 000 m at 8 MHz 88 dB / 1 000 m at 6 MHz 60 dB / 1 000 m at 4 MHz 45 dB / 1 000 m at 3 MHz 4,6 dB / 1 000 m at 93,75 kHz

Table 127 – Round cable II: d.c. power pair specification

Physical characteristics	Specification
Conductor pair size	0,75 mm ² ±0,075 mm ² or 18 AWG max, Cu (Sn plating), Minimum strands is 17 strands. Maximum twist pitch is 1 twist / 50 mm.
Insulation diameter	2,3 mm ±0,23 mm
Colors – (BS+, BS-)	BS+: red, BS-: black
Pair twist	None
Tape shield over pair	None
Electrical characteristics	Specification
Maximum DCR - at 20 °C	25,1 Ω / 1 000 m

Table 128 – Round cable II: general specification

Physical characteristics	Specification
Geometry	Non-paired, 4-conductor twisted. rotation: black, white, red, blue (preferred) or green (optional)
Overall braid shield	N/A
Drain wire	N/A
Outside diameter	About 7,6 mm
Roundness	90 % to 110 %
Jacket marking	Vendor name, part number and additional markings
Electrical characteristics	Specification
Maximum DCR – (braid+tape+drain) at 20 °C	N/A
Applicable environmental characteristics	Specification
Agency certifications	N/A
Flexure	Specified by vender
Bend radius	Specified by vender
Operating ambient temperature	-10 °C to +60 °C
Storage temperature	-20 °C to +65 °C
Minimum pull tension	29,48 kg
Connector compatibility	M12, Open
Topology compatibility	Trunk, Branch

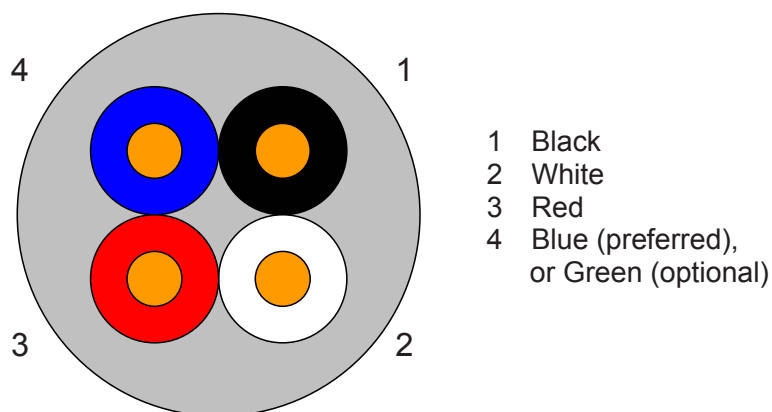

Figure 96 – Outline of round cable II

8.2.5 Flat cable I profile

The following specifications apply to flat cable I:

- data pair specifications, see Table 129;
- power pair specifications, see Table 130;
- general specifications, see Table 131;
- physical configuration, see Figure 97 and Figure 98.

Table 129 – Flat cable I: data pair specification

Physical characteristics	Specification
Conductor pair size	20 strands of 0,18 mm \pm 0,008 mm (0,5mm ²), Cu (Sn plating), Maximum twist pitch is 1 twist / 25 mm.
Insulation diameter	2,54 mm \pm 0,06 mm
Colors – (BDH, BDL)	BDH: white, BDL: blue
Pair twist	None
Tape shield over pair	None
Electrical characteristics	Specification
Impedance	120 Ω \pm 12 Ω (at 1 MHz)
Maximum propagation delay	5,9 ns/m (6 MHz to 40 MHz, 20 °C)
Maximum capacitance between conductors	54,4 pF/m (at 1 kHz, 20 °C)
Maximum capacitance between one conductor and other conductor connected to shield	None
Maximum capacitive unbalance	6 050 pF / 1 000 m, at 100 kHz ASTM D4566
Maximum DCR - at 20 °C	37,5 Ω / 1 000 m
Maximum attenuation:	106 dB / 1 000 m at 8 MHz 81 dB / 1 000 m at 6 MHz 55 dB / 1 000 m at 4 MHz 42 dB / 1 000 m at 3 MHz 5,1 dB / 1 000 m at 93,75 kHz

Table 130 – Flat cable I: d.c. power pair specification

Physical characteristics	Specification
Conductor pair size	30 strands of 0,18 mm \pm 0,008 mm (0,75 mm ²), Cu (Sn plating), Maximum twist pitch is 1 twist / 30 mm
Insulation diameter	2,54 mm \pm 0,06 mm
Colors – (BS+, BS-)	BS+: red, BS-: black
Pair twist	None
Tape shield over pair	None
Electrical characteristics	Specification
Maximum DCR - at 20 °C	25,1 Ω / 1 000 m

Table 131 – Flat cable I: general specification

Physical characteristics	Specification
Geometry	Flat 4-wire
Over braid shield	None
Drain wire	None
Outside diameter	Width: 10,16 mm - 0,5 mm to ± 0 mm; height: 2,54 mm $\pm 0,6$ mm
Roundness	N/A
Jacket marking	Vendor name, part number, and additional markings
Electrical characteristics	Specification
Maximum DCR – (braid+tape+drain) at 20 °C	None
Applicable environmental characteristics	Specification
Agency certification	Specified by vendor
Flexure	Specified by vendor
Bend radius	Specified by vendor
Operating ambient temperature	-10 °C to +55 °C
Storage temperature	-20 °C to +65 °C
Minimum pull tension	18,14 kg
Connector compatibility	Flat connector I
Topology compatibility	Trunk, branch



Figure 97 – Outline of flat cable I

Dimensions in millimetres

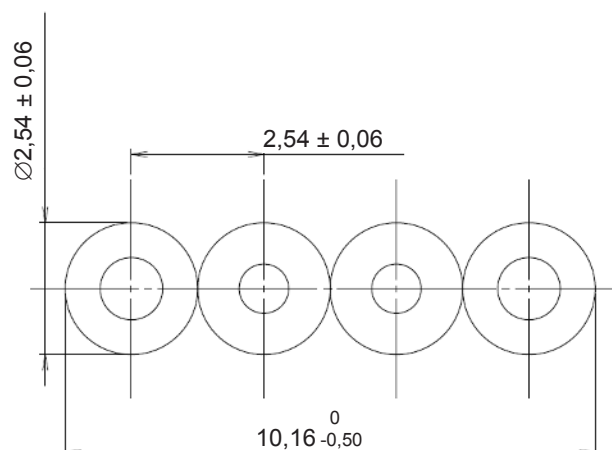

Figure 98 – Dimension of flat cable I

8.2.6 Flat cable II profile

The following specifications apply to flat cable II:

- data pair specifications, see Table 132;
- power pair specifications, see Table 133;
- general specifications, see Table 134;
- physical configuration, see Figure 99 and Figure 100.

Table 132 – Flat cable II: data pair specification

Physical characteristics	Specification
Conductor pair size	20 strands of 0,18 mm \pm 0,008 mm (0,5 mm ²), Cu (Sn plating), Maximum twist pitch is 1 twist / 25 mm
Insulation diameter	2,54 mm \pm 0,06 mm
Colors – (BDH, BDL)	BDH: white, BDL: blue
Pair twist	None
Tape shield over pair	None
Electrical characteristics	Specification
Impedance	120 Ω -24 Ω to 120 Ω +12 Ω (at 1 MHz)
Maximum propagation delay	6,3 ns/m (at 1 kHz, 20 °C)
Maximum capacitance between conductors	89 pF/m (at 100 kHz, 20 °C)
Maximum capacitance between one conductor and other conductor connected to shield	None
Maximum capacitive unbalance	8 910 pF / 1 000 m, at 100 kHz ASTM D4566
Maximum DCR - at 20 °C	37,5 Ω / 1 000 m
Maximum attenuation:	114 dB / 1 000 m at 8 MHz 86 dB / 1 000 m at 6 MHz 59 dB / 1 000 m at 4 MHz 45 dB / 1 000 m at 3 MHz 5,5 dB / 1 000 m at 93,75 kHz

Table 133 – Flat cable II: d.c. power pair specification

Physical characteristics	Specification
Conductor pair size	30 strands of 0,18 mm ±0,008 mm (0,75 mm ²), Cu (Sn plating), Maximum twist pitch is 1 twist / 30 mm
Insulation diameter	2,54 mm ±0,06 mm
Colors - (BS+, BS-)	BS+: red, BS-: black
Pair twist	None
Tape shield over pair	None
Electrical characteristics	Specification
Maximum DCR - at 20 °C	25,1 Ω / 1 000 m

Table 134 – Flat cable II: general specification

Physical characteristics	Specification
Geometry	Flat 4-wire
Over braid shield	None
Drain wire	None
Outside diameter	Width: 12,15 mm ±0,3 mm; height: 4,56 mm ±0,2 mm
Roundness	N/A
Jacket marking	Vendor name, part number and additional markings
Electrical characteristics	Specification
Maximum DCR – (braid+tape+drain) at 20 °C	None
Applicable environmental characteristics	Specification
Agency certification	Specified by vendor
Flexure	Specified by vendor
Bend radius	Specified by vendor
Operating ambient temperature	-10 °C to +55 °C
Storage temperature	-20 °C to +65 °C
Minimum pull tension	36,28 kg
Connector compatibility	Flat connector II
Topology compatibility	Trunk, branch



Figure 99 – Outline of flat cable II

The cable shall be marked with a contrasting stripe in the upper 3/4 quadrant as shown by Figure 99.

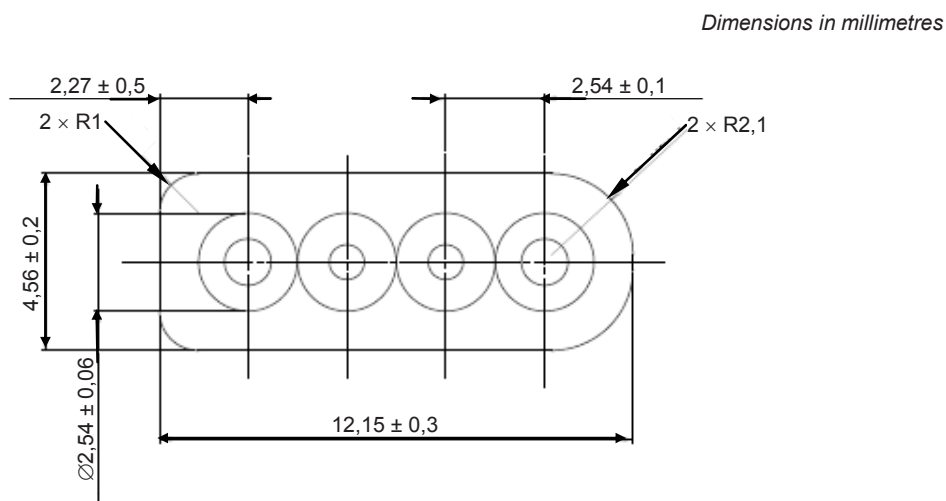

Figure 100 – Dimension of flat cable II

8.3 Terminator

8.3.1 General

A terminator consists of a terminating resistor and a terminating capacitor.

8.3.2 Terminating resistor

A metal film resistor of $121 \Omega \pm 1,21 \Omega$ and 0,25 W shall be connected between BDH and BDL, at an end of a trunk and at the end of a sub-trunk.

8.3.3 Terminating capacitor

A d.c. capacitor of $0,01 \mu\text{F} \pm 0,001 \mu\text{F}$ and more than 50 V shall be connected between BS+ and BS-, at an end of the trunk and at the end of the sub-trunk in all networks using 4-conductor cable.

8.4 Connectors

8.4.1 General

This subclause includes specifications of following connector profiles:

- open connector;
- flat connector I;
- flat connector II;
- sealed M12 connector.

8.4.2 Template

A connector profile defines the male and female orientation, general specifications, contact specifications, electrical specifications and environmental specifications. Table 135 defines the minimum fields that shall be defined for a connector profile.

In this specification plugs are male connectors which mate with jacks which are female connectors. Adapters are cabling accessories used to connect cables of the same type and connectors of the same type which may have different gender. They are normally used in a network to support branching and multi-drop topology.

Table 135 – Connector profile template

Plug general characteristics	Specification
Number of pins	<#>
Coupling nut	<#>
Coupling nut thread	<#>
Rotation	<#>
Standard	<#>
Pinout	BS+: Pin<#>, BDH: Pin<#>, BDL: Pin<#>, BS-: Pin<#>
Jack general characteristics	Specification
Number of pins	<#>
Coupling nut	<#>
Coupling nut thread	<#>
Rotation	<#>
Standard	<#>
Pinout	BS+: Pin<#>, BDH: Pin<#>, BDL: Pin<#>, BS-: Pin<#>
Physical characteristics	Specification
Wiping contact	Nickel under plated over <#> μm,
Plating requirements	Gold plated over <#> μm
Minimum wiping Contact Life	<#> insertion-extractions
Contact physical dimensions	Conform to xxxxx
Electrical characteristics	Specification
Minimum operating voltage	30 V d.c.
Minimum contact rating	<#> A
Maximum contact resistance	<#> mΩ (Initial) <#> mΩ (Final)
Environmental characteristics	Specification
Water resistance	<#>
Oil resistance	<#>
Operating ambient temperature	<#> °C to <#> °C
Storage temperature	<#> °C to <#> °C
Mechanical shock	Acceptance criteria Test conditions
Vibration	Acceptance criteria Test conditions
Cables	Specification
Connectable cable	<Round cable I,.....>

8.4.3 Engaging specification for connector profiles: open, flat I, flat II

All plugs of connectors having this profile shall conform to the specifications in Figure 101 and Figure 102.

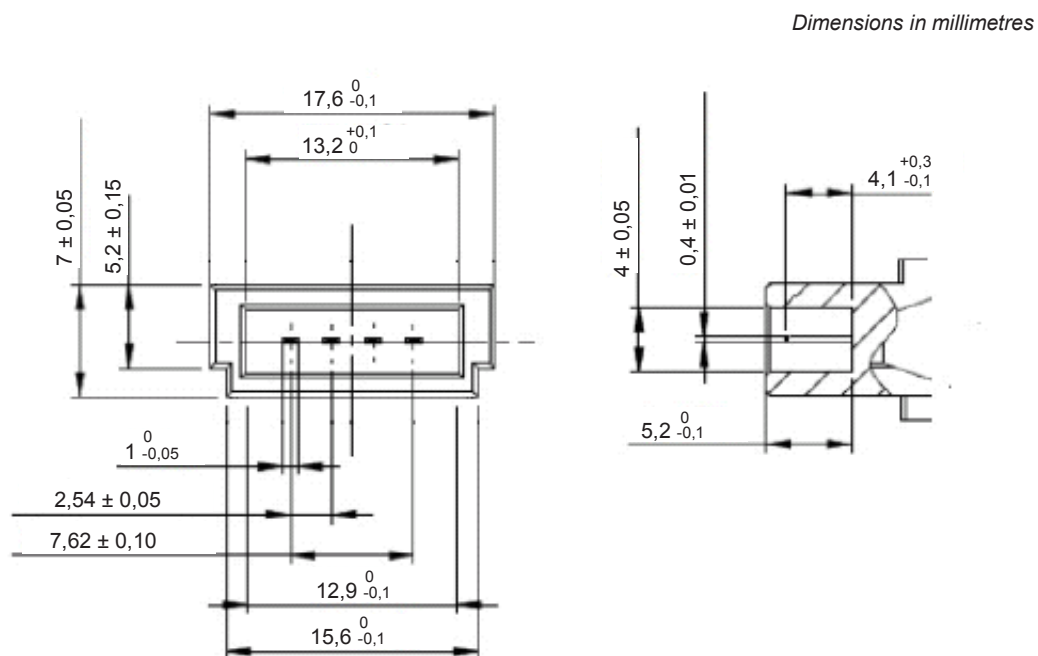
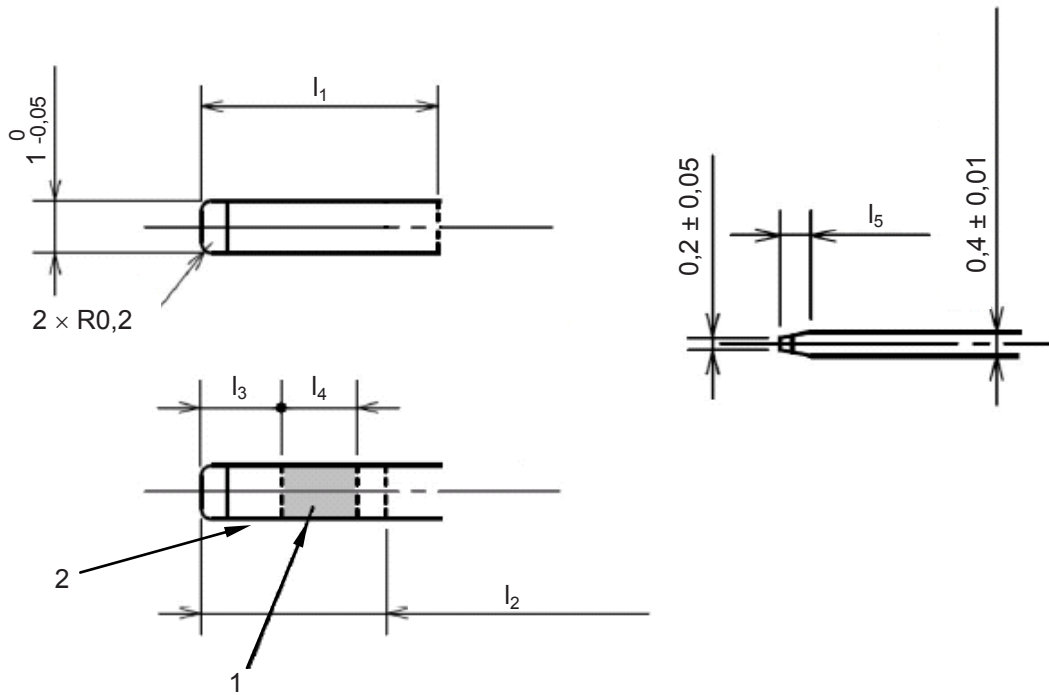

Figure 101 – Engaging dimensions of plug connector

Dimensions in millimetres



Characteristics	l_1	l_2
Minimum of length	4,5	3,5

Characteristics	l_3	l_4	l_5
Length	$1,5 \pm 0,05$	$1,5 \pm 0,05$	$0,5 \pm 0,05$

Key

- 1 Contact area
- 2 Planting area

Figure 102 – Contact space for plug connector

All jacks of connectors having this profile shall conform to the specifications in Figure 103. The dimensions of jack contact are not provided. The jack shall be designed to meet that of plug.

Dimensions in millimetres

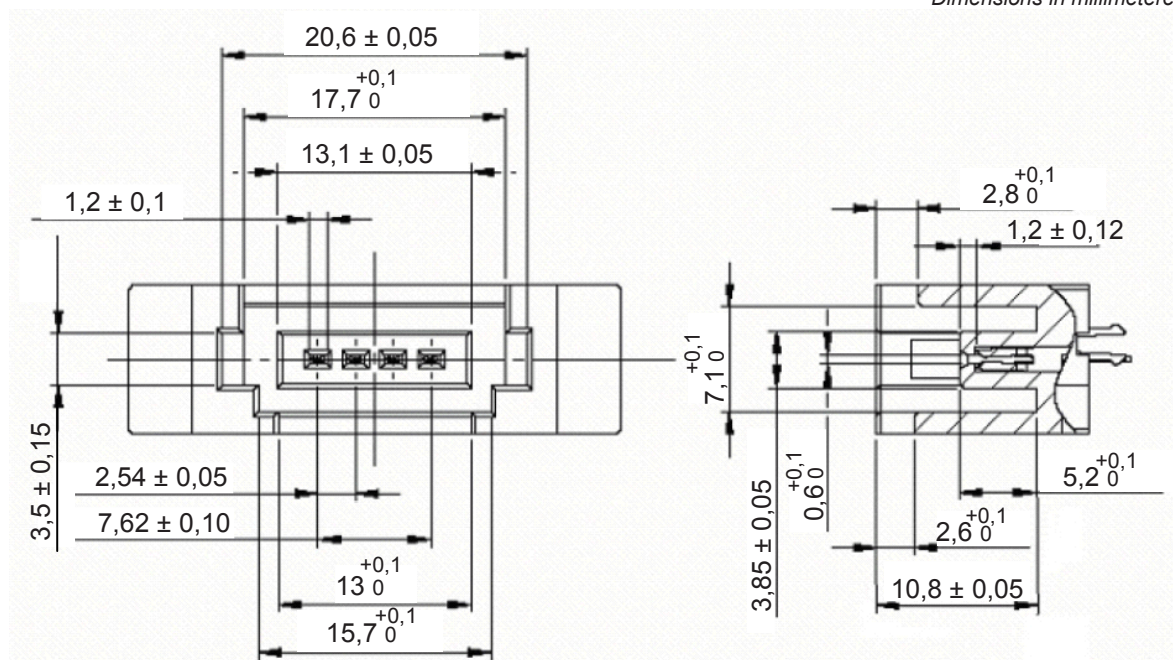

Figure 103 – Engaging dimensions of jack connector

8.4.4 Specifications of hooks for connector profiles: open, flat I, flat II

Hooks are used to lock the connecting parts of jacks and plugs in the mated position. As shown in Figure 104, the jack areas of open connectors, the profile I and profile II shall have internal hooks and notches for external hooks (which are optional). Designs of plug hooks and the jack hooks shall be compatible.

The external hooks are options however experience has shown that Jacks that do not support external hooks are limited in use. It is recommended that vendor catalogues clearly indicate all jacks that do not support external hooks.

Dimensions in millimetres

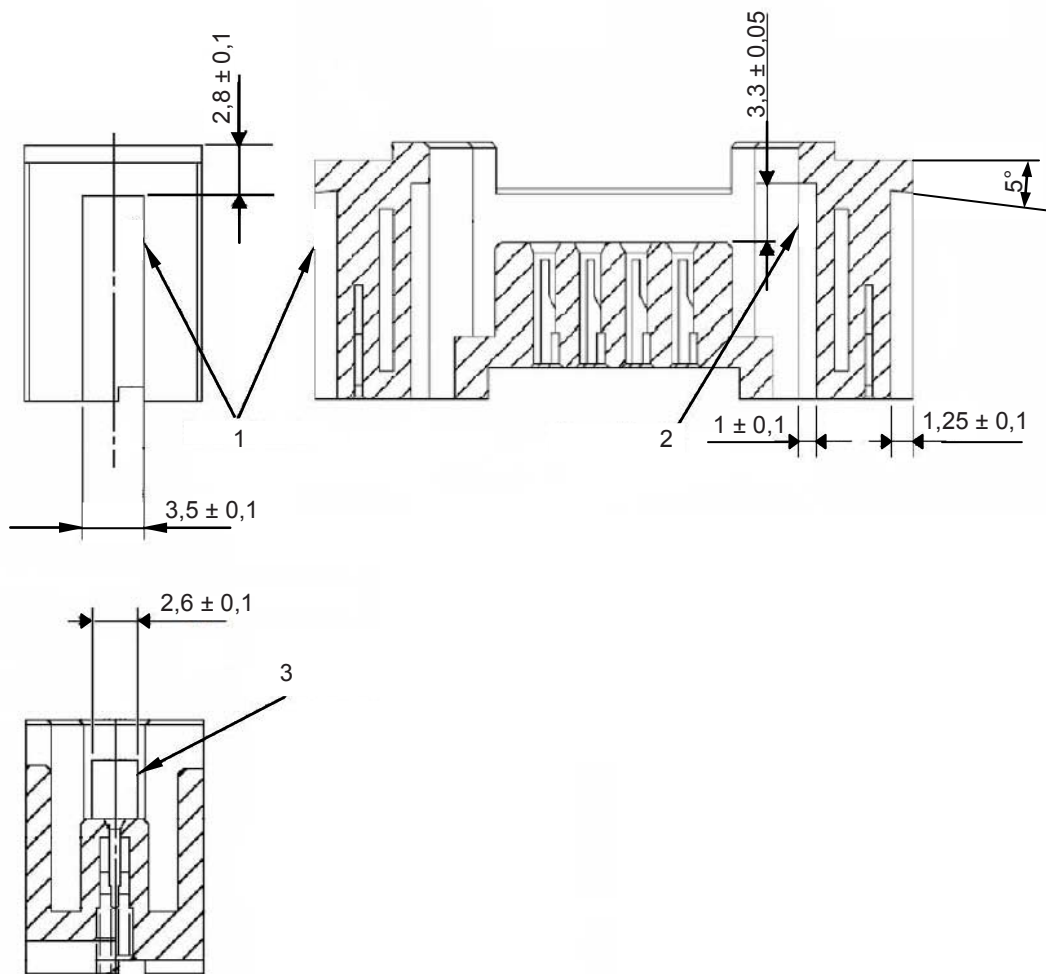

Key

- 1 External hooks
- 2 Internal hooks
- 3 Internal hooks

Figure 104 – Connector hook

8.4.5 Open connector profile

Table 136 defines the open connector profile. Pinout and geometry are defined in Figure 105 and Figure 106.

Table 136 – Specification of open connector

Plug general characteristics	Specification
Number of pins	4
Coupling nut	N/A
Coupling nut thread	N/A
Rotation	N/A
Standard	Specified by vender
Pinout	BS+: Pin1, BDH: Pin2, BDL: Pin3, BS-: Pin4
Jack general characteristics	Specification
Number of pins	4
Coupling nut	N/A
Coupling nut thread	N/A
Rotation	N/A
Standard	Specified by vender
Pinout	BS+: Pin1, BDH: Pin2, BDL: Pin3, BS-: Pin4
Physical characteristics	Specification
Wiping contact	Nickel under plated over 2,0 µm,
Plating requirements	Gold plated over 0,4 µm
Minimum wiping contact life	100 insertion-extractions
Contact physical dimensions	Conform to 8.4.3
Electrical characteristics	Specification
Minimum operating voltage	30 V d.c.
Minimum contact rating	5 A a, b
Minimum contact resistance ^c	40 mΩ (Initial) 50 mΩ (Final) IEC 60512-1 and see Figure 107
Environmental characteristics	Specification
Water resistance	N/A
Oil resistance	N/A
Operating ambient temperature	-30 °C to +55 °C full power with linear de-rating to 2,5 A at 70 °C. b
Storage temperature	-35 °C to +80 °C
Mechanical shock	<u>Acceptance criteria</u> During the test, no current interruption shall last 1 µs or longer. Contact resistance: 50 mΩ or less, Appearance and shape: No physical damage <u>Test conditions</u> Acceleration: 490 m/s ² , Duration: 11 ms. 3 times in each of the 6 direction in 3 axes (Total: 18 times)

Vibration	<p><u>Acceptance criteria</u></p> <p>During the test, no current interruption shall last 1µs or longer.</p> <p>Contact resistance: 50 Ω or less</p> <p>Appearance and shape: No physical damage</p> <p><u>Test conditions</u></p> <p>Frequency: 10 Hz to 500 Hz</p> <p>Sweep time: 20 min.</p> <p>Amplitude: 1,52 mm or 98 m/s²</p> <p>2 h in each of the 3 axes (Total 6 h)</p>
Cables	Specified by vendor
Connectable cable	Round cable I, round cable II, flat cable I
<p>^a Connector mating and un-mating are not supported when the network is powered.</p> <p>^b See Figure 108 for de-rating current.</p> <p>^c This includes the resistance of IDC to wires and the resistance of plug to jack contacts. (see Figure 108)</p>	

Dimensions in millimetres

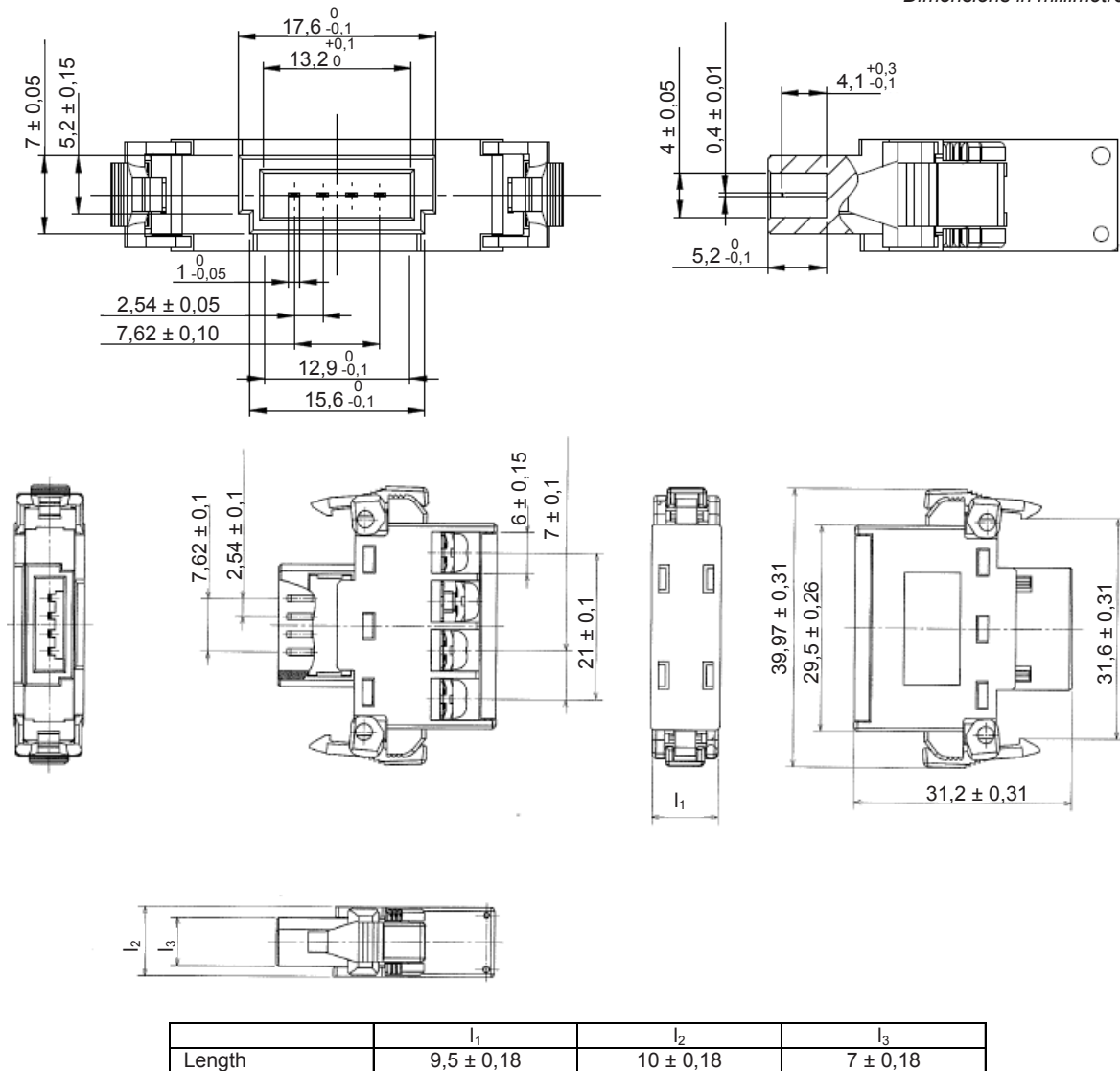

Figure 105 – Open connector plug (informative)

Dimensions in millimetres

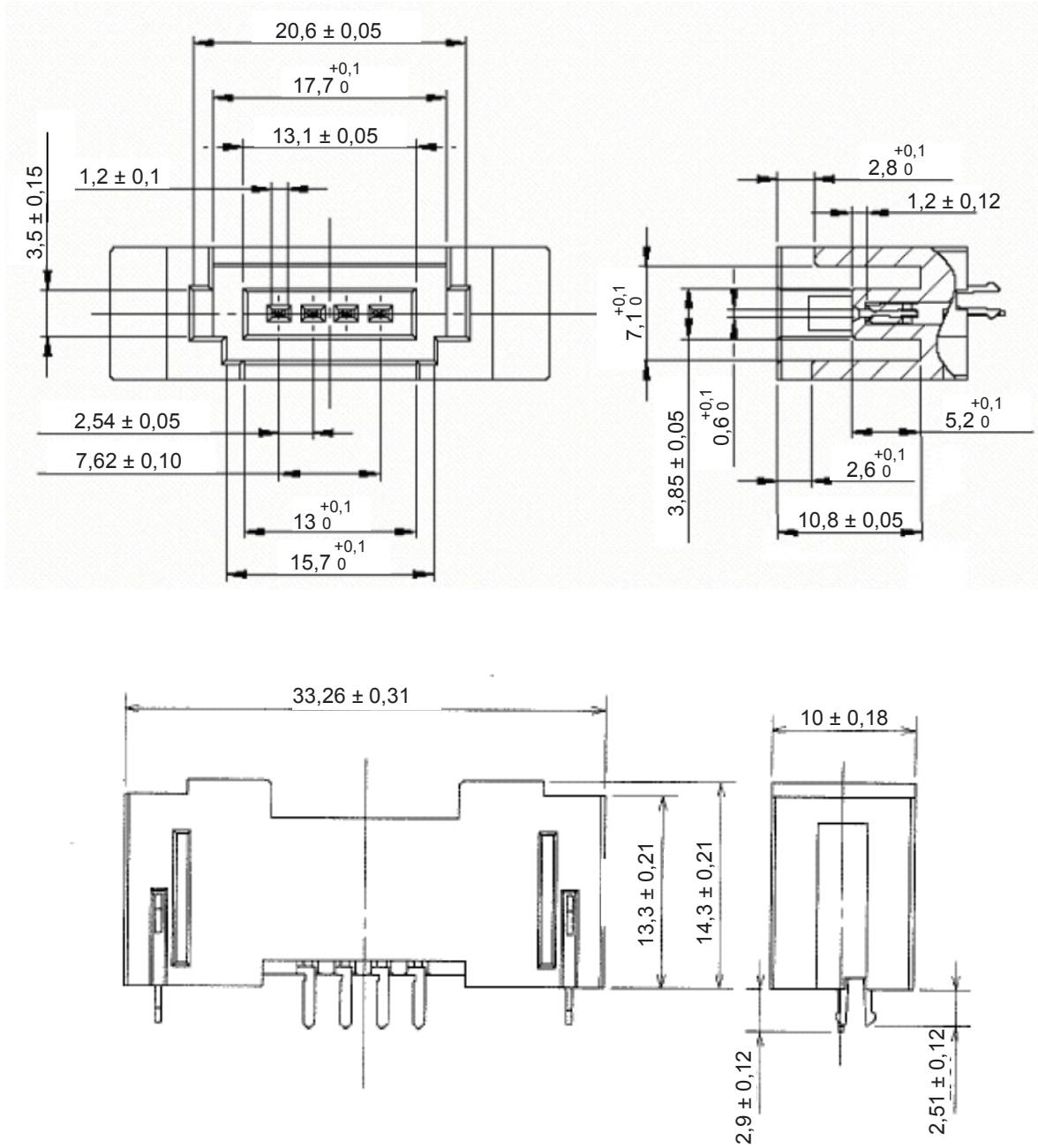

Figure 106 – Open connector jack (informative)

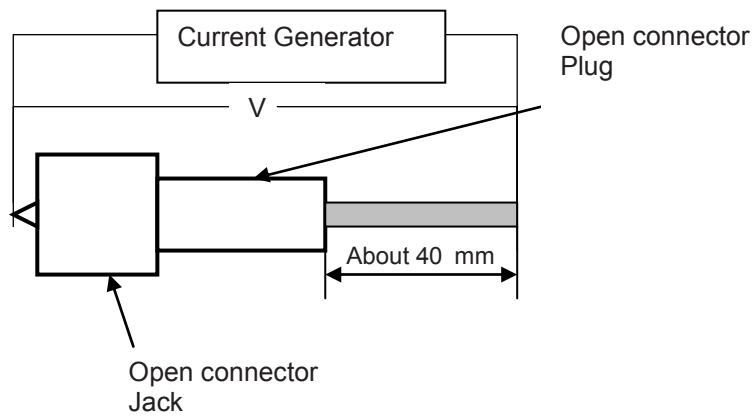

Figure 107 – Method to measure contact resistance (open connectors)

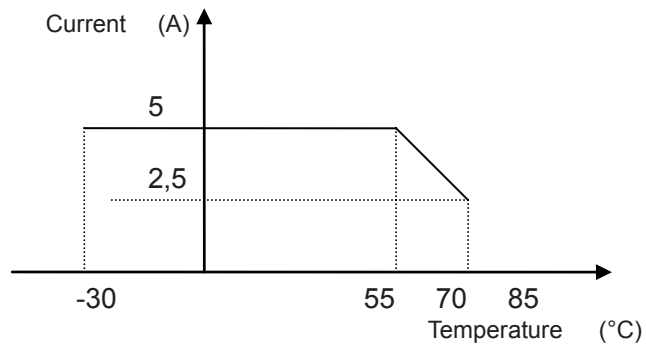

Figure 108 – De-rating current for connectors

8.4.6 Profile of flat connector I

Table 137 defines the flat connector I profile. Pinout and geometry are defined in Figure 109 and Figure 110.

Table 137 – Specification of flat connector I

General characteristics of plugs	Specification
Number of pins	4
Coupling nut	N/A
Coupling nut thread	N/A
Rotation	N/A
Standard	Specified by vendor
Pinout	BS+: Pin1, BDH: Pin2, BDL: Pin3, BS-: Pin4
General characteristics of Jacks	Specification
Number of pins	4
Coupling nut	N/A
Coupling nut thread	N/A
Rotation	N/A
Standard	Specified by vendor
Pinout	BS+: Pin1, BDH: Pin2, BDL: Pin3, BS-: Pin4
Capacitor between BS+ and BS-	0,01 μ F \pm 0,001 μ F or 0,22 μ F \pm 0,022 μ F, 50 V minimum d
Physical characteristics	Specification
Wiping contact	Nickel under plated over 2,0 μ m,
Plating requirements	Gold plated over 0,4 μ m
Minimum wiping contact life	100 insertion-extractions
Contact physical dimensions	Conform to 8.4.3
Electrical characteristics	Specification
Minimum operating voltage	30 V d.c.
Minimum contact rating	5 A ^{a, b}
Maximum contact resistance ^c	40 m Ω (Initial) 50 m Ω (Final) IEC 60512-1 and See Figure 111.
Environmental characteristics	Specification
Water resistance	N/A
Oil resistance	N/A
Operating ambient temperature	-30 °C to +55 °C full power with linear de-rating to 2,5 A at 70 °C. ^b
Storage temperature	-35 °C to +80 °C
Mechanical shock	<u>Acceptance criteria</u> During the test, no current interruption shall occur for 1 μ s or more. Contact resistance: 50 m Ω or less, Appearance and shape: No physical damage <u>Test Conditions</u> Acceleration: 490 m/s ² Duration: 11 ms. 3 times in each of the 6 direction in 3 axes (Total 18 times)
Vibration	<u>Acceptance criteria</u> During the test, no current interruption shall last 1 μ s or longer.

	<p>Contact resistance: 50 mΩ or less</p> <p>Appearance and shape: No physical damage</p> <p><u>Test Conditions</u></p> <p>Frequency: 10 Hz to 500 Hz</p> <p>Sweep time: 20 min.</p> <p>Amplitude: 1,52 mm or 98 m/s²</p> <p>2 hours in each of the 3 axes (Total 6 hours)</p>
Cables	Specification
Connectable cable	Flat cable I
a	Connector mating and un-mating are not supported when the network is powered.
b	See Figure 108 for de-rating current.
c	This includes the resistance of IDC to wires and the resistance of plug to jack contacts. See Figure 111.
d	All jacks in a trunk or a branch shall have a 0,01 μF or 0,22 μF capacitor embedded. For a PC board mounted jack, the capacitor can be mounted to the PC board of a master port or a slave port. See 5.7.3, 5.7.4 and Figure 116.

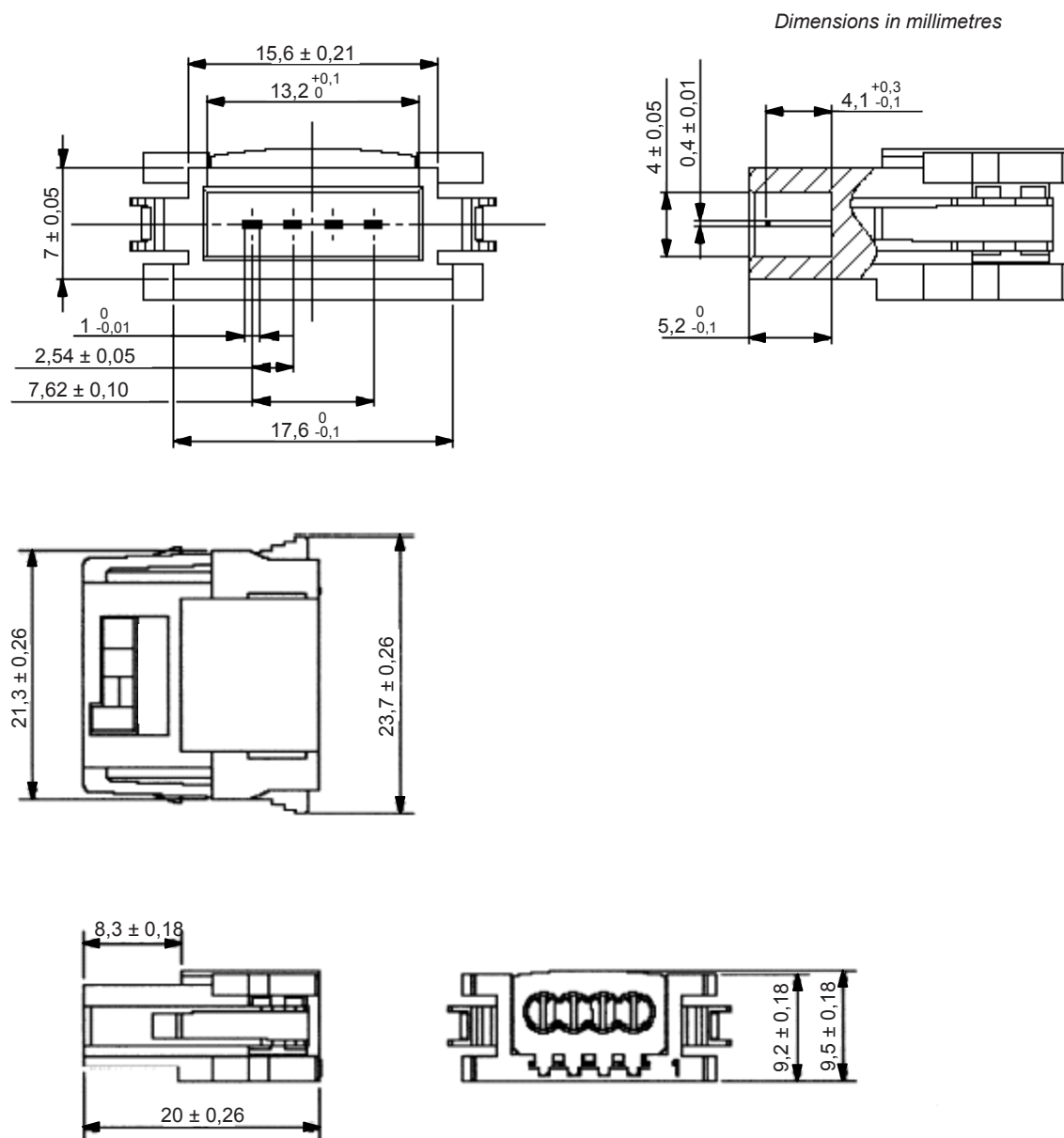

Figure 109 – Flat connector I plug

Dimensions in millimetres

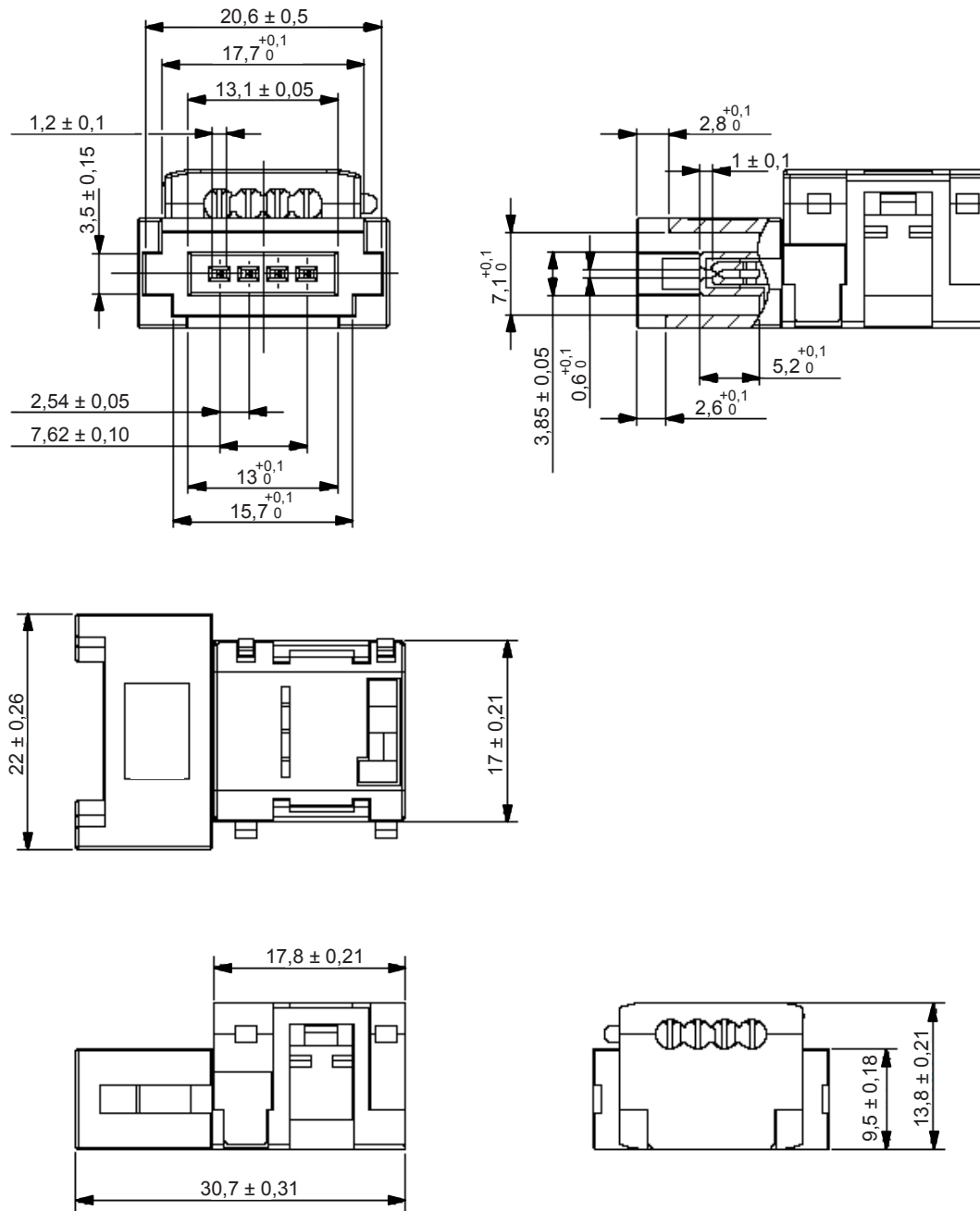

Figure 110 – Flat connector I jack (informative)

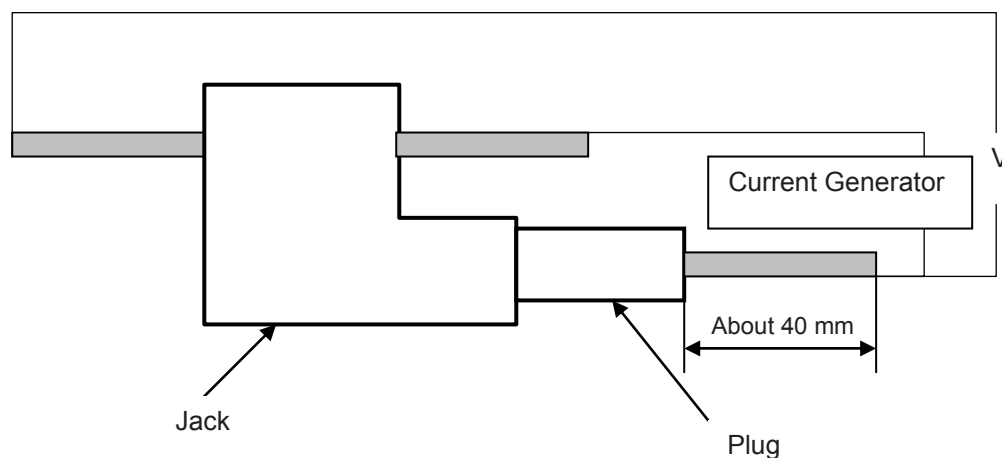

Figure 111 – Method to measure contact resistance (flat I, II connectors)

In the case of a PCB-mounted jack, the contact resistance shall be measured between the PCB pin and the end of 40 mm cable on the plug.

8.4.7 Profile of flat connector II

Table 138 defines the flat connector II profile. Pinout and geometry are defined in Figure 112, Figure 113 and Figure 114.

Table 138 – Specification of flat connector II

General characteristics of Plugs	Specification
Number of pins	4
Coupling nut	N/A
Coupling nut thread	N/A
Rotation	N/A
Standard	
Pinout	BS+: Pin1, BDH: Pin2, BDL: Pin3, BS-: Pin4
General characteristics of jacks	Specification
Number of pins	4
Coupling nut	N/A
Coupling nut thread	N/A
Rotation	N/A
Standard	
Pinout	BS+: Pin1, BDH: Pin2, BDL: Pin3, BS-: Pin4
Capacitor between BS+ and BS-	0,01 μF \pm 0,001 μF or 0,22 μF \pm 0,022 μF , 50 V d.c. minimum ^d
Physical characteristics	Specification
Wiping contact	Nickel under plated over 1,5 μm ,
Plating requirements	Gold plated over 1,2 μm
Minimum wiping contact Life	100 insertion-extractions

Electrical characteristics	Specification
Minimum operating voltage	30 V d.c.
Minimum contact rating	5 A ^{a, b}
Maximum contact resistance ^c	40 mΩ (Initial) 50 mΩ (Final) IEC 60512-1 and See Figure 111.
Contact physical dimensions	Conform to 8.4.3.
Environmental characteristics	Specification
Water resistance	IP54 (according to IEC 60529)
Oil resistance	N/A
Operating ambient temperature	-30 °C to +55 °C full power with linear de-rating to 2,5 A at 70 °C ^b
Storage temperature	-35 °C to +80 °C
Mechanical shock	<u>Acceptance criteria</u> During the test, no current interruption shall last 1 μs or longer. Contact resistance: 50 mΩ or less Appearance and shape: No physical damage <u>Test conditions</u> Acceleration: 490 m/s ² Duration: 11 ms. 3 times in each of the 6 direction in 3 axes (Total 18 times)
Vibration	<u>Acceptance criteria</u> During the test, no current interruption shall last 1 μs or longer. Contact resistance: 50 mΩ or less Appearance and shape: No physical damage <u>Test Conditions</u> Frequency: 10 Hz to 500 Hz Sweep time: 20 min. Amplitude: 1,52 mm or 98 m/s ² 2 hours in each of the 3 axes (total 6 h)
Cables	Specification
Connectable cable	Flat cable II
<p>^a Connector mating and un-mating are not supported when the network is powered.</p> <p>^b See Figure 108 for de-rating current.</p> <p>^c This includes the resistance of IDC to wires and the resistance of plug to jack contact. See 8.4.3.</p> <p>^d For a PC board mounted jack, the capacitor can be mounted to the PC board of a master port or a slave port. See 5.7.3, 5.7.4 and Figure 116.</p>	

Dimensions in millimetres

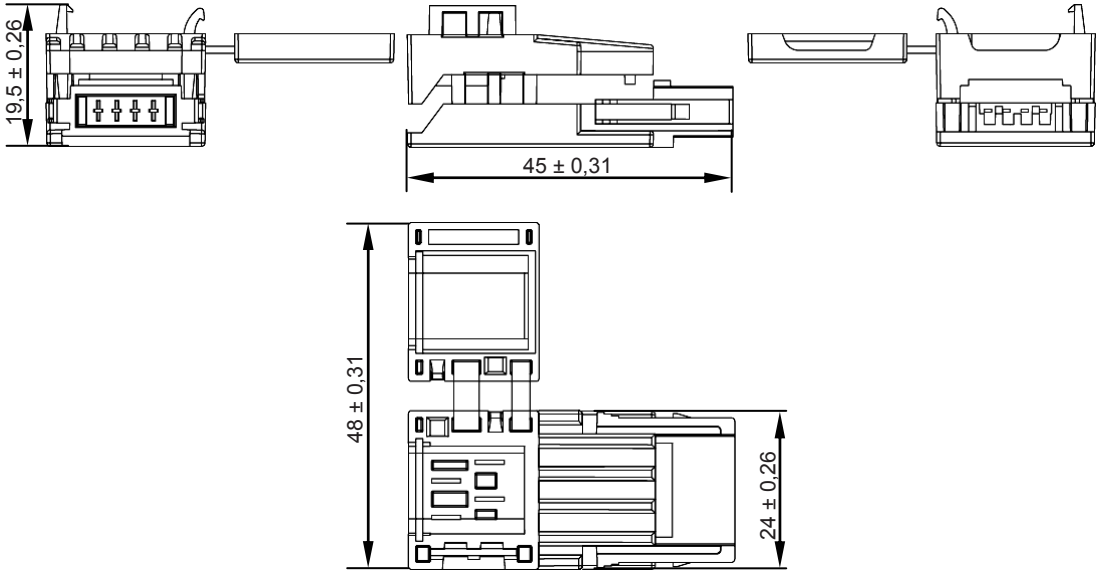

Figure 112 – Flat connector II plug (informative)

Dimensions in millimetres

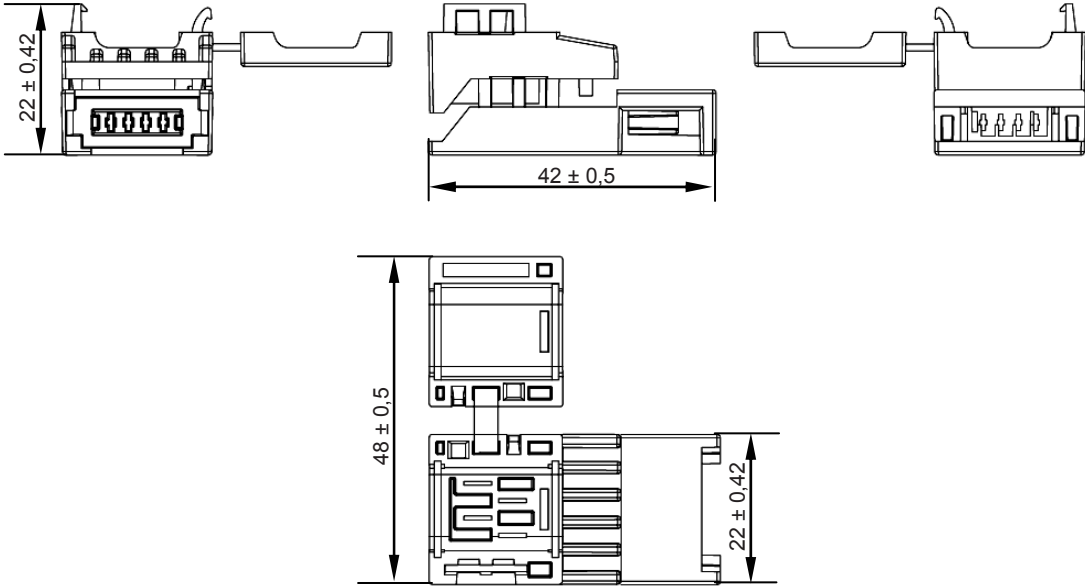

Figure 113 – Flat connector II jack (informative)

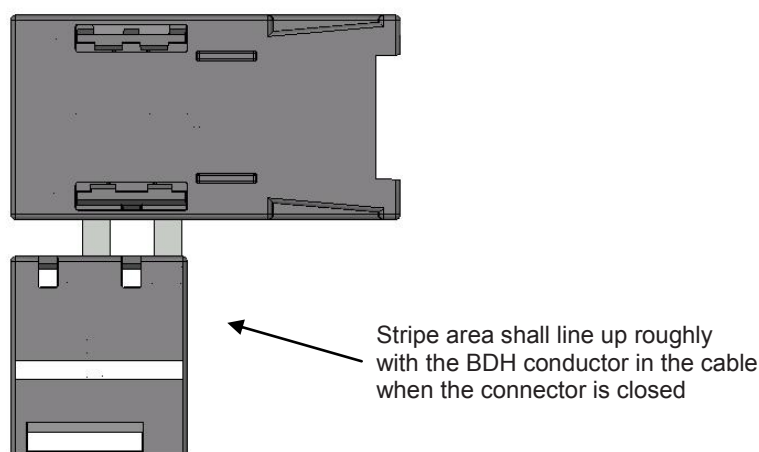

Figure 114 – Marking connector for trunk lines

The connector for trunk line (jack of type flat connector II) shall be marked to match the stripe area defined for flat II cable. See 8.2.6.

8.4.8 Profile of sealed M12 connector

Table 139 defines the sealed M12 connector profile. Pinout and geometry are defined in Figure 115.

Table 139 – Specification of sealed M12 connector

Plug general characteristics	Specification
Number of pins	4
Coupling nut	Male
Coupling nut thread	M12
Rotation	Required
Standard	IEC 61076-2-101
Pinout	BDH: Pin1, BS+: Pin2, BS-: Pin3, BDL-: Pin4
Jack general characteristics	Specification
Number of pins	4
Coupling nut	Female
Coupling nut thread	M12
Rotation	Optional
Standard	IEC 61076-2-101
Pinout	BDH: Pin1, BS+: Pin2, BS-: Pin3, BDL-: Pin4
Physical characteristics	Specification
Wiping contact Plating requirements	30 micro inch gold minimum over 50 micro inch nickel minimum or 5 micro inch gold minimum over 20 micro inch palladium-nickel minimum over 50 micro inch nickel. All gold shall be 24 Karat
Minimum wiping contact life	1 000 insertion-extractions
Electrical characteristics	Specification
Minimum operating voltage	30 V d.c.

Minimum contact rating	3 A, ambient temperature at 20 °C
Maximum contact resistance	1 mΩ (nominal) 5 mΩ over life
Environmental characteristics	Specification
Water resistance	IP67 (according to IEC 60529)
Oil resistance	UL-1277, OIL RES2
Operating ambient temperature	-35 °C to +70 °C
Storage temperature	-35 °C to +80° C
Mechanical shock	IEC 61076-2-101
Vibration	IEC 61076-2-101
Cables	Specification
Connectable cable	Round cable II

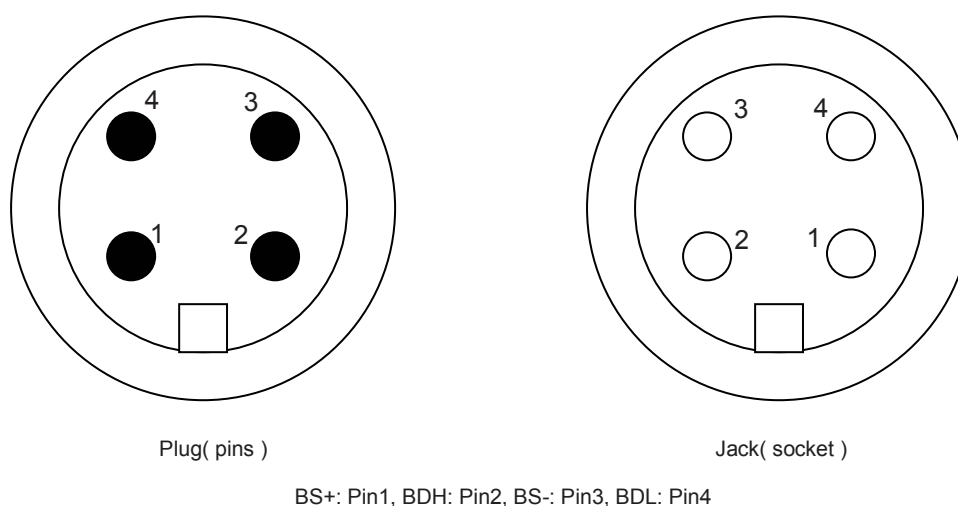

Figure 115 – M12 connector pinout

8.5 Node power supply implementation

8.5.1 General

Devices are able to draw power from the network using this implementation.

If BS+ and BS- of the device are connected to network power supply lines, a 0,01 μF capacitor shall be connected as shown in Figure 116.

Devices may be powered from the network. A slave may use a limiting resistor in series with BS+ as shown in Figure 116.

8.5.2 Requirement for node power supply connection

All node designs shall include the circuit of Figure 116.

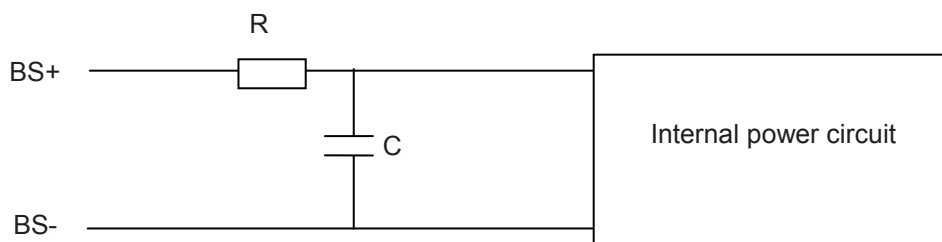

- R This device is either a fuse or a resistor; in either case it shall not exceed 10 Ω
- C 0,01 μF ±10 %, temperature change ratio ±15 %
(operation temperature from minimum to maximum), voltage resist minimum 50 V d.c.

Figure 116 – Link power circuits

8.5.3 The requirements for nodes powered by network power supplies

CompoNet does not limit current consumption for individual nodes powered by a network power supply. But the following requirements shall be considered.

The total current transfer through a segment shall not exceed the cable capability.

The total current taken by a segment shall not exceed the network power supply’s capability.

Operation range for nodes powered by a network power supply: 14 V d.c. to 26,4 V d.c.

Each node shall have at least 2 ms reserve against blackouts or short term power loss which could be caused by temporary short-circuit of d.c. voltage.

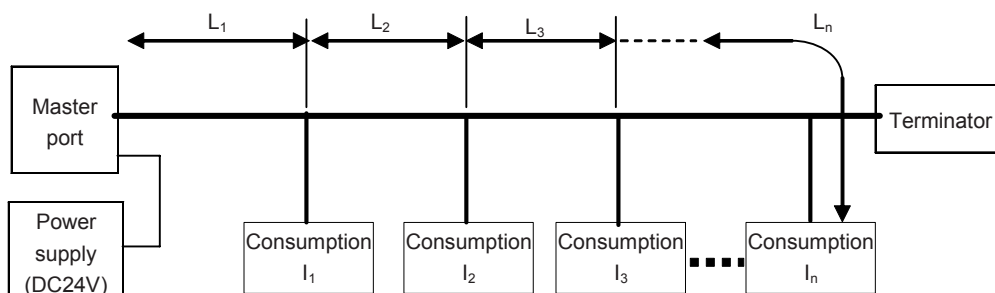

Figure 117 – Power-drop along a cable

The power-drop for node n should be less than (24 V d.c. to 14 V d.c.), see Figure 117:

$$\{(I_1+I_2+I_3+\dots+I_n) \times R_1 \times L_1 \times 2 + (I_2+I_3+\dots+I_n)R_2 \times L_2 \times 2) + (I_3+\dots+I_n) \times R_3 \times L_3 \times 2 + \dots + (I_n \times R_n \times L_n \times 2)\} < 10$$

where

R is DCR of the cable;

L is length of the cable;

I is node consumption current.

The design of nodes powered by network power supplies shall include limits to inrush current, miss-wiring protection and 2 ms blackout capability. Figure 118 provides an implementation example.

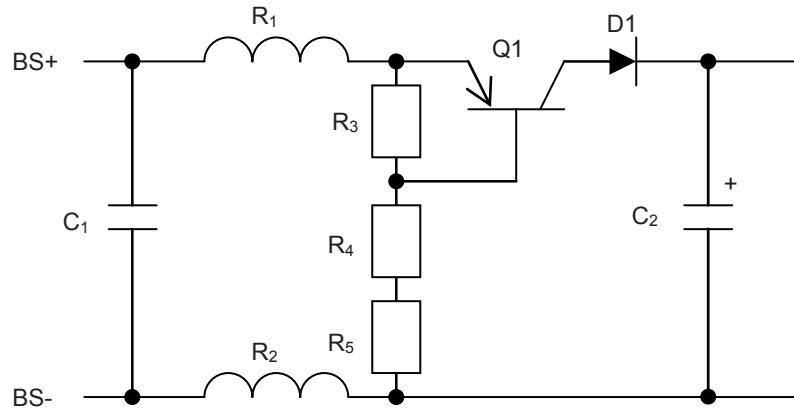

Figure 118 – Power design for a node (informative)

8.6 Miswiring protection

Devices shall be capable of sustaining misconnection without suffering damage if conductors BS+ and BS– are interchanged.

See 9.2.2 for test specifications.

8.7 Electromagnetic compatibility (EMC)

8.7.1 General

All immunity and emission tests are type tests and shall be carried out under representative conditions, both operational and environmental, using the recommended wiring practices and including all equipment necessary for communication and data transfer on the CompoNet cable (see 9.2.8 for test specifications).

8.7.2 Immunity

8.7.2.1 Performance criteria

The test results are specified using the following performance criteria:

- criterion A: no degradation of performance beyond specified limits is allowed when the apparatus is used as intended;
- criterion B: no change of actual operating state or stored data is allowed. During the test, degradation of performance is allowed. No degradation of performance or loss of function beyond specified limits is allowed after the test when the apparatus is used as intended.

8.7.2.2 Electrostatic discharge (ESD) immunity

In accordance with IEC 61000-4-2, 10 discharges of each polarity shall be applied follows:

- a test voltage of ± 8 kV shall be applied by the air gap discharge method to non-metallic device enclosures;
- a test voltage of ± 4 kV shall be applied by the contact discharge method to metallic device enclosures.

Performance criterion B applies.

8.7.2.3 Radiated radio-frequency electromagnetic field immunity

In accordance with IEC 61000-4-3:

- 10 V/m over the frequency range 80 MHz to 1 000 MHz, amplitude modulated.

Performance criterion A applies.

8.7.2.4 Electrical fast transient/burst immunity

In accordance with IEC 61000-4-4:

- a maximum test voltage of ± 1 kV at 5 kHz shall be applied to cables that contain the CDI communication medium;
- a maximum test voltage of ± 2 kV at 5 kHz shall be applied to all other cables and ports.

Performance criterion B applies.

8.7.2.5 Surge immunity

In accordance with IEC 61000-4-5:

- five surges at a maximum of ± 2 kV shall be applied between a.c. mains line and earth;
- five surges at a maximum of ± 1 kV shall be applied between a.c. mains lines.

Performance criterion B applies.

8.7.2.6 Conducted radio-frequency disturbance immunity

In accordance with IEC 61000-4-6:

- 10 V r.m.s. over the frequency range 150 kHz to 80 MHz, amplitude modulated.

Performance criterion A applies.

8.7.2.7 Voltage dips and interruptions

Conformity of the power supply to the specified limits given in 5.7.11.1 eliminates the need for any further testing.

8.7.3 Emissions

8.7.3.1 Radiated emissions

This test shall be performed in accordance with CISPR 11, group 1, class A.

8.7.3.2 Conducted emissions

This test shall be performed in accordance with CISPR 11, group 1, class A.

9 Tests

9.1 General

This clause specifies type tests for electrical, mechanical, and logical requirements. The tests are divided into three parts:

- electrical testing,
- mechanical testing, and
- logical testing.

NOTE If CompoNet specifications are implemented as an integral part of a product, some logical tests may depend on the behaviour of the product itself. Conformance of a device to this part of the standard does not necessarily mean conformance to system requirements or other standards for applications which include CompoNet. Testing specific applications of CompoNet functions is outside the scope of this part of the standard.

The tests applicable to a specific EUT shall be performed in the sequence indicated.

9.2 Electrical testing

9.2.1 Slave port operation voltage test

9.2.1.1 Test purpose

The following tests are to verify correct slave port operation at the specified range of supply voltage. The test is only applicable to devices fitted with an MS indicator.

9.2.1.2 Test circuit

The test circuit shall be as shown in Figure 119.

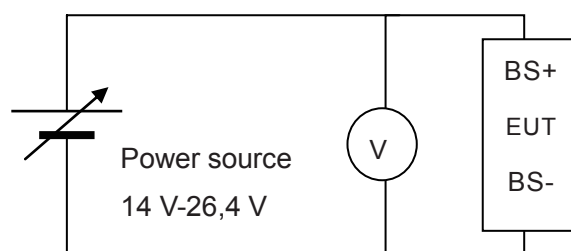

Figure 119 – Operating voltage test circuit

9.2.1.3 Test procedure

The Power of 14,0 V shall be supplied to EUT, and proper LED indication shall be confirmed. Then power of 26,4 V shall be supplied to it, and proper LED indication shall be confirmed.

9.2.1.4 Criteria for compliance

The MS LED indicator shall light solid green.

9.2.2 Reverse connected power supply line

9.2.2.1 Test purpose

The purpose of this test is to verify compliance with the requirements for protection of power supply reverse connection at a slave port.

9.2.2.2 Test circuit

The test circuit shall be as shown in Figure 120.

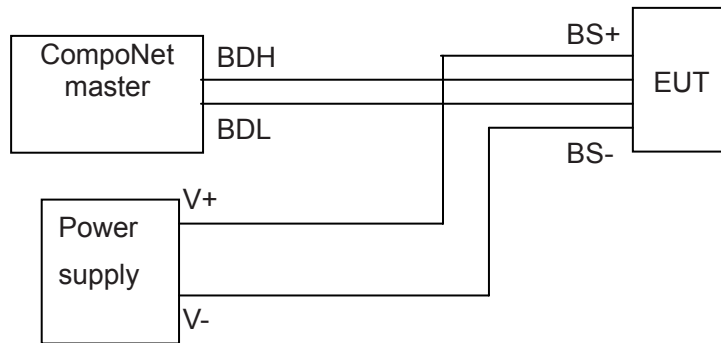

Figure 120 – Reverse connected power supply line

9.2.2.3 Test procedure

The BS+ terminal of EUT shall be connected to the V- of power supply, and the BS- terminal of EUT shall be connected to the V+ of power supply for 60 s, then returned to its normal state.

9.2.2.4 Criteria for compliance

When the wiring has been returned to its normal state, proper communication between the device and the master shall be verified.

9.2.3 Momentary power interruption

9.2.3.1 Test purpose

The purpose of this test is to verify compliance with the requirements for momentary power interruption.

9.2.3.2 Test circuit

The test circuit shall be as shown in Figure 120.

9.2.3.3 Test procedure

During normal communication between the master and the EUT, the power shall be switched off for 2 ms.

9.2.3.4 Criteria for compliance

Momentary power interruption shall not cause any communication error.

9.2.4 Isolation

9.2.4.1 Test purpose

The purpose of this test is to verify compliance with the requirements node isolation.

9.2.4.2 Test circuit

The test circuit shall be as shown in Figure 121.

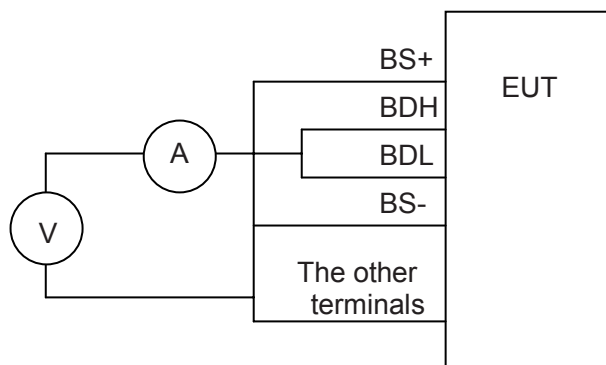

Figure 121 – Isolation

9.2.4.3 Test procedure

The terminals BDH and the BDL shall be shunted. Power of 500 V a.c. (50 Hz or 60 Hz) shall be applied for 1 min between them and other terminals to check leakage of current.

9.2.4.4 Criteria for compliance

The leakage current shall be 5 mA or less.

9.2.5 Input impedance

9.2.5.1 Test purpose

The purpose of this test is to verify compliance with the physical layer input impedance specification.

9.2.5.2 Test circuit

The test circuit shall be as shown in Figure 122.

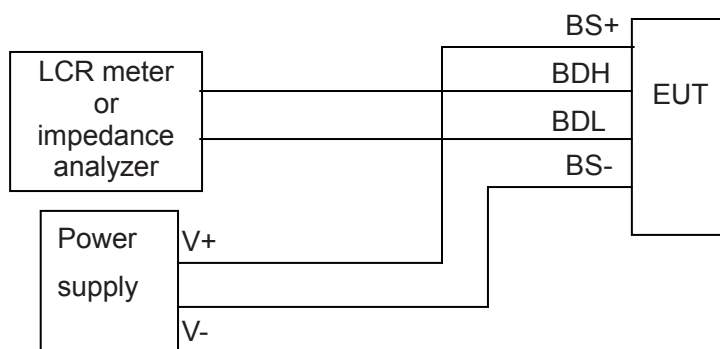

Figure 122 – Input impedance

9.2.5.3 Test procedure

The EUT shall be switched on, and the impedance shall be measured at frequencies of 750 kHz and 4 MHz.

9.2.5.4 Criteria for compliance

The input impedance value at each physical layer port shall be within the standard value defined in the Table 140 for master, and Table 141 for slave.

Table 140 – Input impedance for master

Frequency	Impedance
750 kHz	140 Ω to 164 Ω
4 MHz	116 Ω to 135 Ω

Table 141 – Input impedance for slave

Frequency	Impedance
750 kHz	847 Ω to 985 Ω
4 MHz	476 Ω to 555 Ω

9.2.6 Output waveform

9.2.6.1 Test purpose

The purpose of this test is to verify compliance with the transmitting waveform specification at a node.

9.2.6.2 Test circuit

The test circuit shall be as shown in Figure 64 for master port.

The test circuit shall be as shown in Figure 123 for slave port.

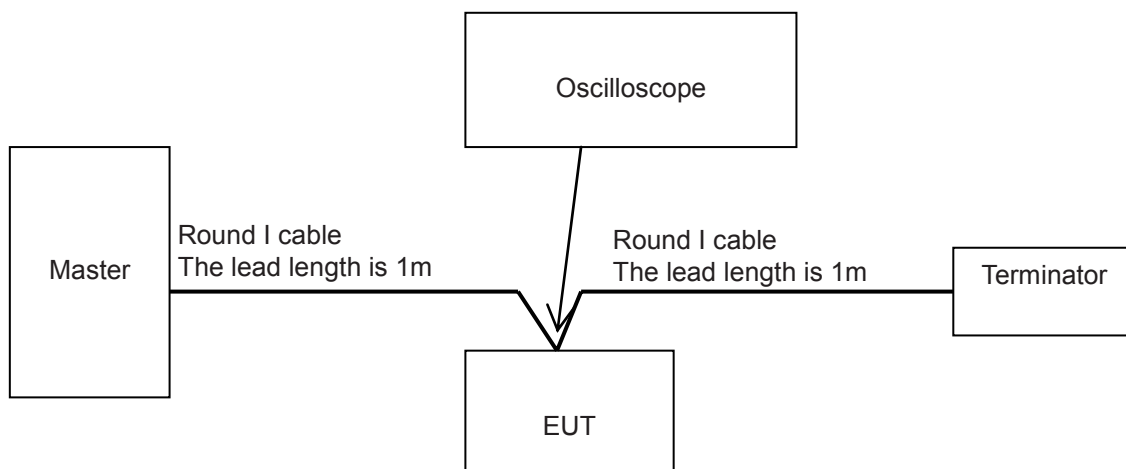

Figure 123 – Output slave test circuit for slave port

9.2.6.3 Test procedure

The waveform between the BDH and the BDL of the EUT shall be recorded in an oscilloscope. The test shall be conducted at two data rates: 4 Mbit/s and 92,75 kbit/s.

9.2.6.4 Criteria for compliance

The measured waveforms shall conform to the requirements shown in 5.7.3.4.1 for master port, and 5.7.4.4.1 for slave port.

9.2.7 Minimum input waveform

9.2.7.1 Test purpose

The purpose of this test is to verify compliance with the receiving signal specification for a master port and a slave port.

9.2.7.2 Test circuit

The test circuit shall be as shown in Figure 124 for master ports and slave ports.

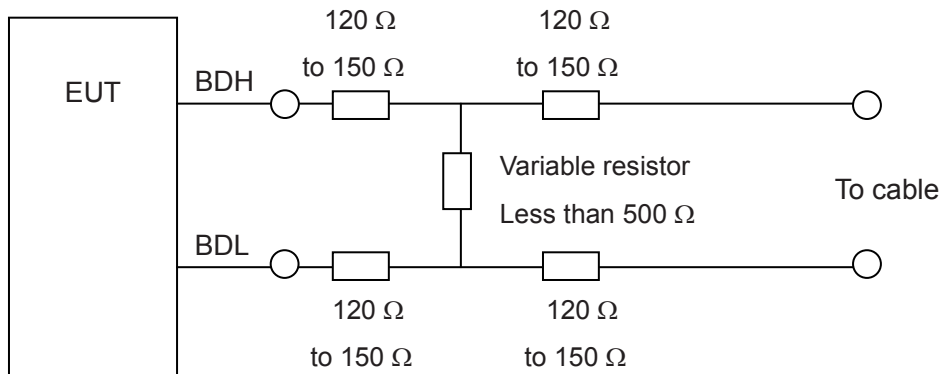

Figure 124 – Minimum input waveform test circuit

9.2.7.3 Test procedure

The data rate shall be 4 Mbit/s. The variable resistor shall be adjusted so that the transmission signals entered in the EUT conform to those on Figure 125.

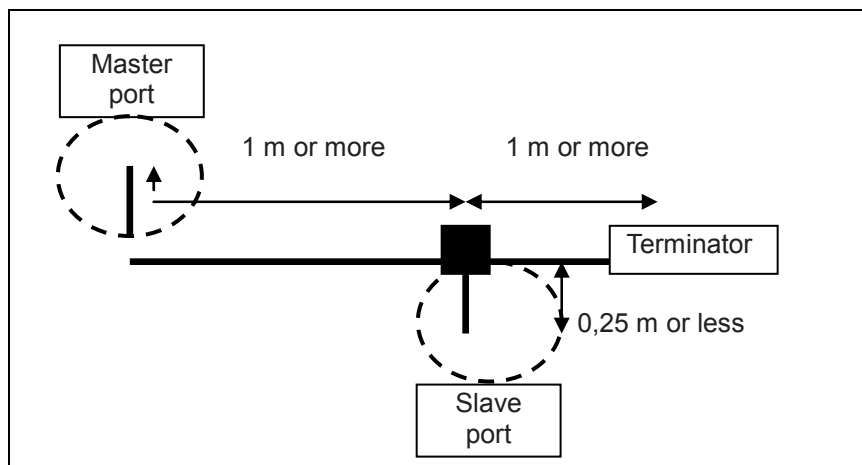

Figure 125 – Minimum input waveform test system

9.2.7.4 Criteria for compliance

Normal communication shall be maintained for all waveforms within the specified masks.

9.2.8 Electromagnetic compatibility testing

9.2.8.1 General

The system shall be tested whilst operating at the maximum bit rate supported by the EUT. Unless otherwise noted, the tests shall be carried out at an ambient temperature of 23 °C ±5 °C. The EUT shall be mounted in free air and shall be connected to the CompoNet CDI according to the manufacturer's instructions and supplied with its rated voltage.

Criteria for compliance shall be as specified in the listed specifications.

NOTE The criteria are those listed in the specifications of 8.7.2 "Immunity".

9.2.8.2 Immunity

9.2.8.2.1 Electrostatic discharge (ESD) immunity

This test shall be performed in accordance with 8.7.2.2.

9.2.8.2.2 Radiated radio-frequency electromagnetic field immunity

This test shall be performed in accordance with 8.7.2.3.

9.2.8.2.3 Electrical fast transient/burst immunity

This test shall be performed in accordance with 8.7.2.4.

9.2.8.2.4 Surge immunity

This test shall be performed in accordance with 8.7.2.5.

9.2.8.2.5 Conducted radio-frequency disturbance immunity

This test shall be performed in accordance with 8.7.2.6

9.2.8.3 Emissions

9.2.8.3.1 Radiated emissions

This test shall be performed in accordance with 8.7.3.1.

9.2.8.3.2 Conducted emissions

This test shall be performed in accordance with 8.7.3.2.

9.3 Mechanical test

None required in this subclause.

9.4 Logical test

9.4.1 General

The logical tests shall only be performed on nodes that support the particular functionality being tested.

9.4.2 Test of slaves and repeaters

9.4.2.1 General

This subclause contains protocol test items, methods and criteria for the following target nodes: Word IN slaves, Word OUT slaves, Bit IN slaves, Bit OUT slaves and repeaters. A MIX slave is referred to as an IN slave for the test purpose. The target node is also called a Device Under Test or a DUT.

9.4.2.2 System configuration

The test equipments shall include:

- a CompoNet master which allows manual transmission of frames and recording of responses, and
- a 24 V d.c. power supply.

The target node address shall be set to 31.

NOTE This address selection aims to check for correctness of the time domain – the node responds with CN frame in 4th bus cycle if it is targeted with setting of 8 CN frames per bus cycle, 2nd bus cycle if 16 CN frames, and at last CN frame position of every bus cycle if 32 CN frames.

The test configuration is as shown in Figure 126.

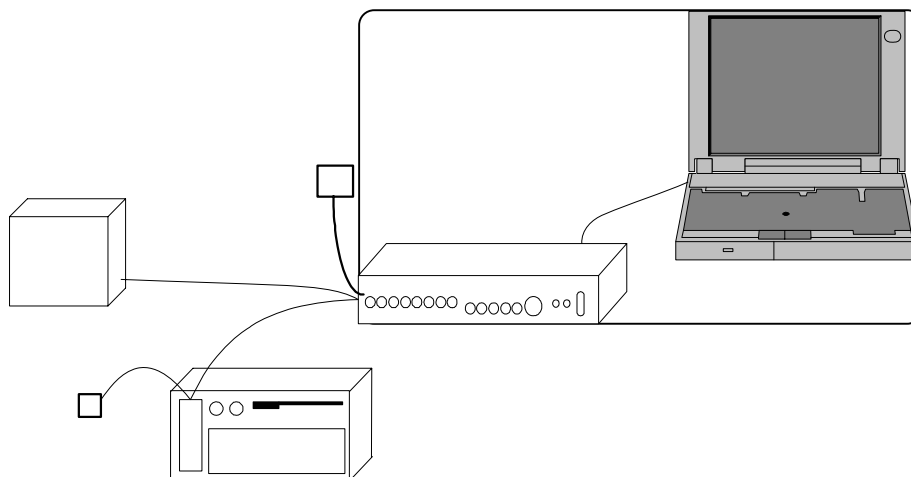

Figure 126 – Data link test for slave and repeater DUT

Unless otherwise provided, this test shall be performed at a data rate of 4 Mbit/s.

9.4.2.3 Test of frame types

9.4.2.3.1 BEACON

9.4.2.3.1.1 Test purpose

This test verifies correct transmission speed detection at 4 Mbit/s, 3 Mbit/s, 1,5 Mbit/s and 93,75 kbit/s.

9.4.2.3.1.2 Test procedure

The master shall be configured to search for a DUT, and check it is in the normal operation state. The test shall be conducted in the following sequence:

- search for a non-participated DUT;
- send STRNP;
- send STWNP_Run;
- send ALLOCATE;
- send poll; and
- check the response in each case.

**Power
Supply**

This set of tests shall be executed at transmission speeds of 4 Mbit/s, 3 Mbit/s, 1,5 Mbit/s and 93,75 kbit/s.

9.4.2.3.1.3 Criteria for compliance

The DUT shall communicate with the master without error, and the correct response shall be received.

9.4.2.3.2 B_EVENT

9.4.2.3.2.1 Test purpose

This test verifies correct responses of STR and STW.

9.4.2.3.2.2 Test procedure

The following items shall be conducted and the response shall be recorded.

- a) STRNP shall be sent to the DUT when it is in the “offline state”.
- b) STWNP shall be sent to the DUT when it is in the “offline state”.
- c) STRP shall be sent to the DUT when it is in the “online state”.
- d) STWP shall be sent to the DUT when it is in the “online state”.
- e) STRNP shall be sent to the DUT when it is in the “online state”.
- f) STWNP shall be sent to the DUT when it is in the “online state”.
- g) STRP shall be sent to the DUT when it is in the “offline state”.
- h) STWP shall be sent to the DUT when it is in the “offline state”.
- i) STWP_Reset shall be sent to the DUT when it is in the “online state”.
- j) STWNP_Reset shall be sent to the DUT when it is in the “offline state”.

9.4.2.3.2.3 Criteria for compliance

The test items performed by 9.4.2.3.2.2 shall meet the following criteria respectively.

- a) The STRNP response data shall be correct in VendorCode, DeviceType, InIoModeStatus, OutIoModeStatus, ProductCode and MajorRevision. If the DUT is a repeater, RepeaterMode shall be 1. If not, it shall be 0.
- b) STWNP shall be acknowledged.
- c) STRP shall be acknowledged.
- d) STWP shall be acknowledged.
- e) STRNP shall not be acknowledged.
- f) STWNP shall not be acknowledged.
- g) STRP shall not be acknowledged.
- h) STWP shall not be acknowledged.
- i) DUT shall be reset.
- j) DUT shall be reset.

9.4.2.3.3 A_EVENT

This test is included in other tests. No individual test is required here.

9.4.2.3.4 CN

9.4.2.3.4.1 Test purpose

This test verifies the DUT duplicate check function.

9.4.2.3.4.2 Test procedure

The master shall be search for a non-participating DUT without issuing any STR.

9.4.2.3.4.3 Criteria for compliance

The DUT shall make the transition to Communication Fault state.

9.4.2.3.5 IN

9.4.2.3.5.1 Test purpose

This test shall be executed for a DUT that includes the IN function, i.e. for Word IN/MIX devices and Bit IN/MIX devices. It verifies the timing of IN frames.

9.4.2.3.5.2 Test procedure

The master shall be configured to test the DUT in its normal operation state. The time between start of transmission of an IN frame and completion of the previous OUT or TRG frame shall be recorded.

9.4.2.3.5.3 Criteria for compliance

The recorded time shall be within 0,1% of “InTimeDomain” in STW.

9.4.2.4 Duplicate MAC ID detection

9.4.2.4.1 Test purpose

The test verifies the duplicate check function of a DUT.

9.4.2.4.2 Test procedure

The master shall be configured to issue STWNP with parameter “Serial Number = 0xFFFFFFFF”. The test shall be conducted in the following sequence:

- a) search for a non-participated DUT;
- b) send STRNP;
- c) send STWNP_Run with parameter “Serial Number = 0xFFFFFFFF”; and
- d) check the DUT.

9.4.2.4.3 Criteria for compliance

The DUT shall be in Communication Fault state.

9.4.3 Test of master

9.4.3.1 Test of minimum traffic

9.4.3.1.1 Purpose

This test verifies that a master DUT is able to send out BEACON frames and OUT or TRG frames to initialize communication with connected slaves and repeaters.

9.4.3.1.2 Test configuration

The test equipment shall include:

- a frame analyzer to catch frames on the wire, and
- a 24 V d.c. power supply.

Figure 127 shows the test configuration to check the minimum traffic of a master DUT.

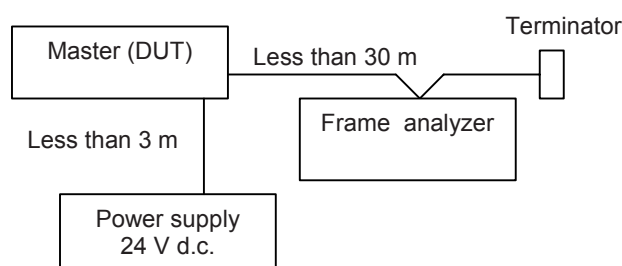

Figure 127 – Test configuration for minimum traffic of master DUT

9.4.3.1.3 Test procedure

The test shall be conducted in the following sequence:

- a) configure the network as shown in Figure 127;
- b) run any analyzer software needed to set up;
- c) start to capture network traffic;
- d) power the master;
- e) let the DUT start communication;
- f) stop the capture process after approximately 10 s of network traffic has been captured, following the DUT start of sending frames, or the analyzer buffer becoming full; and
- g) check the captured frames against the criteria.

9.4.3.1.4 Criteria for compliance

The test performed by 9.4.3.1.3 shall meet the following criteria respectively:

- a) at least one frame shall be sent every 30 ms.
- b) at least one BEACON shall be sent every 250ms.
- c) the “Speed Code” in BEACON shall match the data rate, the “Gate Counter” shall be 0, and the “Last Repeater Node Address” shall be 0.
- d) there are OUT and TRG frames to request CN frames for non-participated nodes.
- e) the OUT and TRG frames shall be sent at least once per 650 ms when the transmission speed is 93,75 kbit/s, and at least once per 200 ms for other speeds.

9.4.3.2 Test of proxy

9.4.3.2.1 Purpose

This test verifies the proxy function of a master DUT.

9.4.3.2.2 Test configuration

The test equipments shall include:

- a special device shown as “Special slave 1” in Figure 128 with the ability to send explicit messages to other slaves,
- a standard slave, and
- a 24 V d.c, power supply.

Figure 128 shows the test configuration to see minimum traffic of a master DUT.

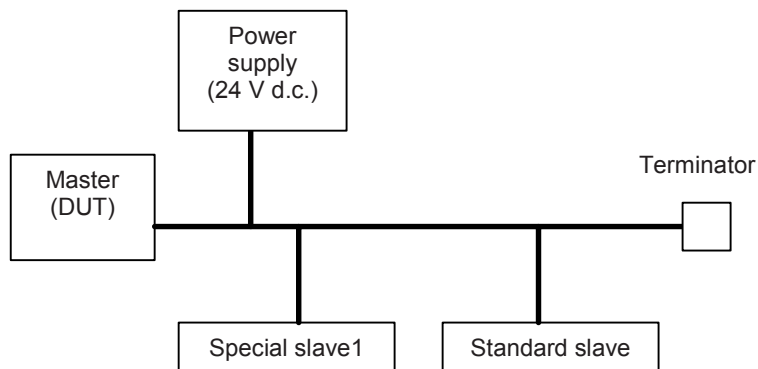

Figure 128 – Test configuration for proxy of master DUT

9.4.3.2.3 Test procedure

The test shall be conducted in the following sequence:

- a) configuring network per Figure 128;
- b) creating I/O connections between DUT and slaves.
- c) letting special slave 1 issue an explicit request addressed to the standard slave;
- d) checking response received by special slave 1.

9.4.3.2.4 Criterial for compliance

The special slave 1 shall receive an explicit message response from the standard slave.

Annex A (normative)

CompoNet common services

CompoNet shall use CIP common services (see IEC 61158-5-2, 6.2.1.3 and IEC 61158-6-2, 4.1.8).

No additional common services exist in CompoNet at this time.

Annex B (normative)

CompoNet error codes

B.1 General

CompoNet shall use error codes defined in CIP (see IEC 61158-5-2, 6.2.1.3.3 and IEC 61158-6-2, 4.1.11) and error codes defined in the following section.

B.2 Additional error codes

The additional error codes are defined in Table B.1.

Table B.1 – Newly defined CompoNet error codes

Error code (hex)	Error name	Description of error
23	Buffer Overflow	The message received is larger than the receiving buffer can handle. The entire message was discarded.
24	Message Format Error	The format of the received message is not supported by the server.

Annex C (normative)

Connection path attribute definition

CompoNet shall use CIP connection path definitions (see IEC 61158-6-2, 4.1.9).

No additional connection path attribute definitions exist in CompoNet at this time.

Annex D (normative)

Data type specification and encoding

D.1 General

CompoNet shall use the CIP definition of data type specification and encoding which is specified in IEC 61158-5-2, Clause 5 and IEC 61158-6-2, 4.2 and Clause 5.

Additions are presented in the following.

D.2 CompoNet CRC Algorithms

D.2.1 CompoNet CRC Algorithms

The C++ routines below generate CRC16 and CRC8 via the polynomial driven method.

EXAMPLE

```
CRCH crc;

unsigned short CRC_CCITT= ~crc.crc_ccitt(data,bitsize);

unsigned char CRC8= ~crc.crc_8(data,bitsize);
```

A CRC generation class definition:

```
class CRCH
{
private:

    // CRC-CCITT(CRC-ANSI)
    // Left shift (LSB -> MSB)
    unsigned short crc_ccitt_word(unsigned short crc, unsigned char dat, int bit_len)
    {
        int j, flg;

        if(bit_len <= 0) {
            return crc;
        } else if(bit_len > 8) {
            bit_len = 8;
        }

        // 8bit repeating
        for (j = 0; j < bit_len; ++j) {
            // check, then left-shift
```

```
    flg = ((crc >> 15) ^ (dat & 1)); // CRC's MSB XORs dat's LSB.
    crc <<= 1; // 1bit shift
    dat >>= 1;
    if(flg) { // Need a logic operation?
        crc ^= 0x1021; // CRC-CCITT
    }
}
return crc;
}
```

```
// CRC-8
// Left shift (LSB -> MSB)
unsigned char crc_8_byte(unsigned char crc, unsigned char dat, int bit_len)
{
    int j, flg;
    if(bit_len <= 0) {
        return crc;
    } else if(bit_len > 8) {
        bit_len = 8;
    }
    // 8bit repeating operation
    for (j = 0; j < bit_len; ++j) {
        // Check MSB, then left shift;
        flg = (((crc>>7) ^ dat) & 0x1); // CRC's MSB XORs dat's LSB
        crc <<= 1; // 1bit shift
        dat >>= 1;
        if(flg) { // Need a logic operation?
            crc ^= 0x9b; // CRC-8
        }
    }
    return crc;
}
```

public:

```
// CRC-CCITT(CRC-ANSI)
```

```
// Left shift (LSB -> MSB)
unsigned short crc_ccitt(unsigned char *data, int bit_len)
{
    int i, len;
    unsigned short crc;
    // Initial value
    crc = 0xffff;
    len = bit_len >> 3;
    for(i = 0; i < len; ++i) {        // Get a octet
        crc = crc_ccitt_word(crc, *(data+i), 8);
    }
    crc = crc_ccitt_word(crc, *(data+i), bit_len & 0x0007);
    return crc;
}

// CRC-8
// Left shift (LSB -> MSB)
unsigned char crc_8(unsigned char *data, int bit_len)
{
    int i, len;
    unsigned char  crc;
    // Initial value
    crc = 0xff;
    len = bit_len >> 3;
    for(i = 0; i < len; ++i) {
        // Get 1 octet
        crc = crc_8_byte(crc, *(data+i), 8);
    }
    crc = crc_8_byte(crc, *(data+i), bit_len & 0x0007);
    return crc;
}
};
```

D.2.2 An example to Generate CompoNet CRC

An example of CRC generation for OUT frames is shown in Figure D.1

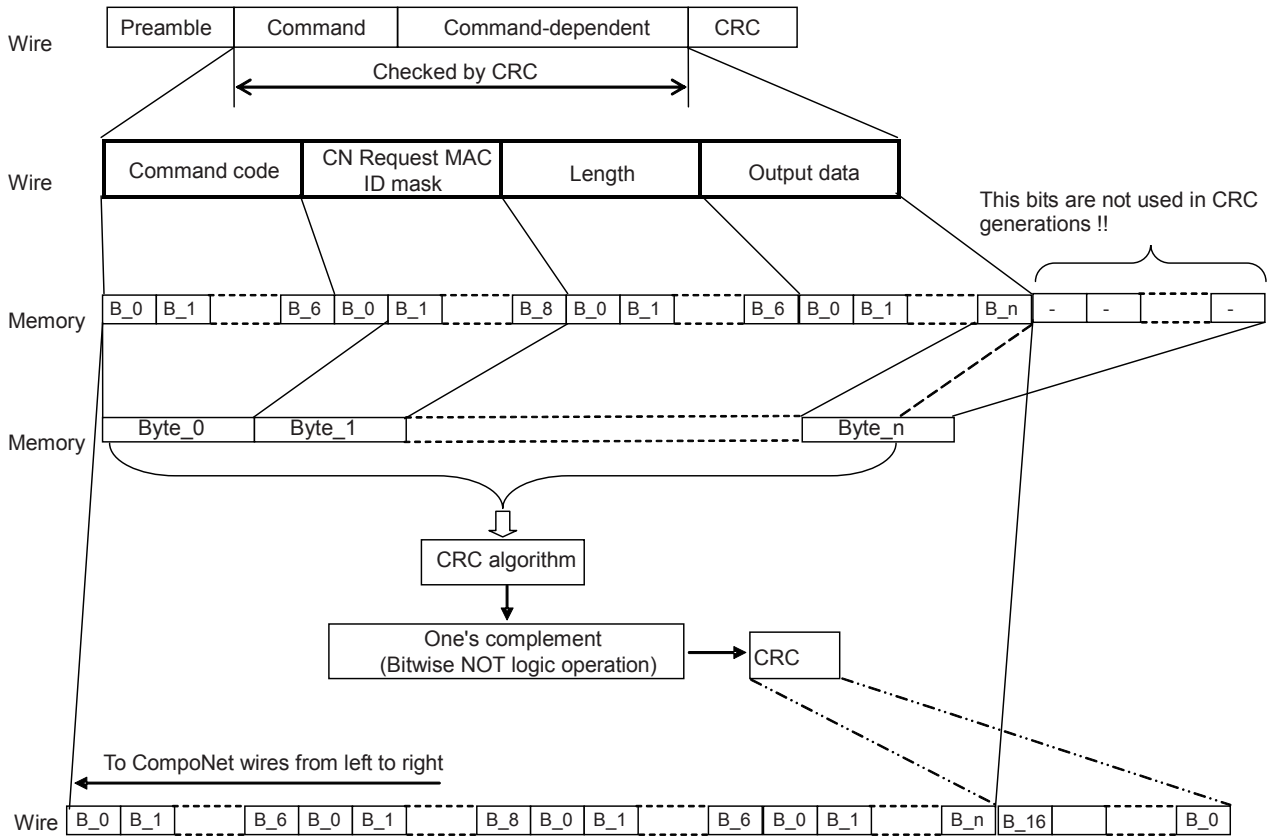

Figure D.1 – An example to generate CRC

Annex E (normative)

Communication objects library

CompoNet link object and repeater object are fully defined in 5.3.5 and 5.3.6 respectively.

Other object class codes and their names are specified in IEC 61158-6-2, 4.1.10.2.1.

Annex F (normative)

Value ranges

CompoNet shall use value ranges defined in IEC 61158-6-2, 4.1.10. Additionally, MAC ID and node address ranges are defined in Table F.1.

Table F.1 – MAC ID and node address ranges

Device category	Node address	MAC ID
Master	0 only	0x1C0 (448)
Word IN	0 - 0x3F	0x0-0x3F (0-63)
Word OUT	0 - 0x3F	0x40-0x7F (64-127)
Word MIX	0 - 0x3F	0x0-0x3F (0-63)
Bit IN	0 - 0x7F	0x80-0xFF (128-255)
Bit OUT	0 - 0x7F	0x100-0x17F (256-383)
Bit MIX	0 - 0x7F	0x80-0xFF (128-255)
Repeater	0 - 0x3F	0x180-0x1BF (384-447)
NOTE MIX and IN devices share the same range of MAC ID.		

Annex G (normative)

CN default time domain

This annex contains additions to the CN Default Time Domain.

The default CN time domain depends on the Control Code in BEACON frames. It is calculated by algorithms presented in 5.6.3. The values in Table G.1, Table G.2, Table G.3 and Table G.4 are rounded values from these calculation. All nodes shall comply with the values in these tables.

The unit of CN time domain is Marks

Table G.1 – CN default time domain table for 4 Mbit/s data rate

Control code	Node address	1 st segment	2 nd segment	3 rd segment
0	0+4*n	170	106	42
	1+4*n	286	222	158
	2+4*n	402	338	274
	3+4*n	518	454	390
1	0+8*n	170	106	42
	1+8*n	286	222	158
	2+8*n	402	338	274
	3+8*n	518	454	390
	4+8*n	634	570	506
	5+8*n	750	686	622
	6+8*n	866	802	738
2	7+8*n	982	918	854
	0+16*n	170	106	42
	1+16*n	286	222	158
	2+16*n	402	338	274
	3+16*n	518	454	390
	4+16*n	634	570	506
	5+16*n	750	686	622
	6+16*n	866	802	738
	7+16*n	982	918	854
	8+16*n	1 099	1 035	971
	9+16*n	1 216	1 152	1 088
	10+16*n	1 333	1 269	1 205
	11+16*n	1 450	1 386	1 322
	12+16*n	1 567	1 503	1 439
	13+16*n	1 684	1 620	1 556
14+16*n	1 801	1 737	1 673	
15+16*n	1 918	1 854	1 790	

Table G.2 – CN default time domain table for 3 Mbit/s data rate

Control code	Node address	1 st segment	2 nd segment	3 rd segment
0	0+4*n	170	106	42
	1+4*n	286	222	158
	2+4*n	402	338	274
	3+4*n	518	454	390
1	0+8*n	170	106	42
	1+8*n	286	222	158
	2+8*n	402	338	274
	3+8*n	518	454	390
	4+8*n	634	570	506
	5+8*n	750	686	622
	6+8*n	866	802	738
	7+8*n	982	918	854
2	0+16*n	170	106	42
	1+16*n	286	222	158
	2+16*n	402	338	274
	3+16*n	518	454	390
	4+16*n	634	570	506
	5+16*n	750	686	622
	6+16*n	866	802	738
	7+16*n	982	918	854
	8+16*n	1 099	1 035	971
	9+16*n	1 216	1 152	1 088
	10+16*n	1 333	1 269	1 205
	11+16*n	1 450	1 386	1 322
	12+16*n	1 567	1 503	1 439
	13+16*n	1 684	1 620	1 556
	14+16*n	1 801	1 737	1 673
	15+16*n	1 918	1 854	1 790

Table G.3 – CN default time domain table for 1,5 Mbit/s data rate

Control code	Node address	1 st segment	2 nd segment	3 rd segment
0	0+4*n	170	106	42
	1+4*n	304	240	176
	2+4*n	438	374	310
	3+4*n	572	508	444
1	0+8*n	170	106	42
	1+8*n	304	240	176
	2+8*n	438	374	310
	3+8*n	572	508	444
	4+8*n	706	642	578
	5+8*n	840	776	712
	6+8*n	974	910	846
2	7+8*n	1 109	1 045	981
	0+16*n	170	106	42
	1+16*n	304	240	176
	2+16*n	438	374	310
	3+16*n	572	508	444
	4+16*n	706	642	578
	5+16*n	840	776	712
	6+16*n	974	910	846
	7+16*n	1 109	1 045	981
	8+16*n	1 244	1 180	1 116
	9+16*n	1 379	1 315	1 251
	10+16*n	1 514	1 450	1 386
	11+16*n	1 649	1 585	1 521
	12+16*n	1 784	1 720	1 656
	13+16*n	1 919	1 855	1 791
14+16*n	2 055	1 991	1 927	
15+16*n	2 191	2 127	2 063	

Table G.4 – CN default time domain table for 93,75 kbit/s data rate

Control code	Node address	1 st segment	2 nd segment	3 rd segment
0	0+4*n	170	106	42
	1+4*n	280	216	152
	2+4*n	390	326	262
	3+4*n	500	436	372
1	0+8*n	170	106	42
	1+8*n	280	216	152
	2+8*n	390	326	262
	3+8*n	500	436	372
	4+8*n	610	546	482
	5+8*n	720	656	592
	6+8*n	830	766	702
	7+8*n	940	876	812
2	0+16*n	170	106	42
	1+16*n	280	216	152
	2+16*n	390	326	262
	3+16*n	500	436	372
	4+16*n	610	546	482
	5+16*n	720	656	592
	6+16*n	830	766	702
	7+16*n	940	876	812
	8+16*n	1 051	987	923
	9+16*n	1 162	1 098	1 034
	10+16*n	1 273	1 209	1 145
	11+16*n	1 384	1 320	1 256
	12+16*n	1 495	1 431	1 367
	13+16*n	1 606	1 542	1 478
	14+16*n	1 717	1 653	1 589
15+16*n	1 828	1 764	1 700	

Bibliography

- [1] IEC 61000-4-11, *Electromagnetic compatibility (EMC) – Part 4-11: Testing and measurement techniques – Voltage dips, short interruptions and voltage variations immunity tests*
IEC 61000-4-11 NOTE Harmonised as EN 61000-4-11.
 - [2] IEC 61158 (all parts), *Industrial communication networks – Fieldbus specifications*
IEC 61158 series NOTE Harmonised in EN 61158 series.
 - [3] IEC 62026-3:2008, *Low-voltage switchgear and controlgear – Controller-device interfaces (CDIs) – Part 3: DeviceNet*
IEC 62026-3:2008 NOTE Harmonised as EN 62026-3:2009 (not modified).
 - [4] TIA/EIA-485-A:1998, *Electrical Characteristics of Generators and Receivers for Use in Balanced Digital Multipoint Systems*
-

British Standards Institution (BSI)

BSI is the national body responsible for preparing British Standards and other standards-related publications, information and services.

BSI is incorporated by Royal Charter. British Standards and other standardization products are published by BSI Standards Limited.

About us

We bring together business, industry, government, consumers, innovators and others to shape their combined experience and expertise into standards-based solutions.

The knowledge embodied in our standards has been carefully assembled in a dependable format and refined through our open consultation process. Organizations of all sizes and across all sectors choose standards to help them achieve their goals.

Information on standards

We can provide you with the knowledge that your organization needs to succeed. Find out more about British Standards by visiting our website at bsigroup.com/standards or contacting our Customer Services team or Knowledge Centre.

Buying standards

You can buy and download PDF versions of BSI publications, including British and adopted European and international standards, through our website at bsigroup.com/shop, where hard copies can also be purchased.

If you need international and foreign standards from other Standards Development Organizations, hard copies can be ordered from our Customer Services team.

Subscriptions

Our range of subscription services are designed to make using standards easier for you. For further information on our subscription products go to bsigroup.com/subscriptions.

With **British Standards Online (BSOL)** you'll have instant access to over 55,000 British and adopted European and international standards from your desktop. It's available 24/7 and is refreshed daily so you'll always be up to date.

You can keep in touch with standards developments and receive substantial discounts on the purchase price of standards, both in single copy and subscription format, by becoming a **BSI Subscribing Member**.

PLUS is an updating service exclusive to BSI Subscribing Members. You will automatically receive the latest hard copy of your standards when they're revised or replaced.

To find out more about becoming a BSI Subscribing Member and the benefits of membership, please visit bsigroup.com/shop.

With a **Multi-User Network Licence (MUNL)** you are able to host standards publications on your intranet. Licences can cover as few or as many users as you wish. With updates supplied as soon as they're available, you can be sure your documentation is current. For further information, email bsmusales@bsigroup.com.

BSI Group Headquarters

389 Chiswick High Road London W4 4AL UK

Revisions

Our British Standards and other publications are updated by amendment or revision.

We continually improve the quality of our products and services to benefit your business. If you find an inaccuracy or ambiguity within a British Standard or other BSI publication please inform the Knowledge Centre.

Copyright

All the data, software and documentation set out in all British Standards and other BSI publications are the property of and copyrighted by BSI, or some person or entity that owns copyright in the information used (such as the international standardization bodies) and has formally licensed such information to BSI for commercial publication and use. Except as permitted under the Copyright, Designs and Patents Act 1988 no extract may be reproduced, stored in a retrieval system or transmitted in any form or by any means – electronic, photocopying, recording or otherwise – without prior written permission from BSI. Details and advice can be obtained from the Copyright & Licensing Department.

Useful Contacts:

Customer Services

Tel: +44 845 086 9001

Email (orders): orders@bsigroup.com

Email (enquiries): cservices@bsigroup.com

Subscriptions

Tel: +44 845 086 9001

Email: subscriptions@bsigroup.com

Knowledge Centre

Tel: +44 20 8996 7004

Email: knowledgecentre@bsigroup.com

Copyright & Licensing

Tel: +44 20 8996 7070

Email: copyright@bsigroup.com



...making excellence a habit.™