



BSI Standards Publication

Maritime navigation and radiocommunication equipment and systems — Automatic Identification System (AIS)

Part 2: Class A shipborne equipment of the universal automatic identification system (AIS) — Operational and performance requirements, methods of test and required test results

National foreword

This British Standard is the UK implementation of EN 61993-2:2013. It is identical to IEC 61993-2:2012. It supersedes BS EN 61993-2:2002 which is withdrawn.

The UK participation in its preparation was entrusted to Technical Committee EPL/80, Maritime navigation and radiocommunication equipment and systems.

A list of organizations represented on this committee can be obtained on request to its secretary.

This publication does not purport to include all the necessary provisions of a contract. Users are responsible for its correct application.

© The British Standards Institution 2013.

Published by BSI Standards Limited 2013

ISBN 978 0 580 56603 5

ICS 33.060.20; 47.020.70

Compliance with a British Standard cannot confer immunity from legal obligations.

This British Standard was published under the authority of the Standards Policy and Strategy Committee on 31 March 2013.

Amendments issued since publication

Date	Text affected
-------------	----------------------

English version

**Maritime navigation and radiocommunication equipment and systems -
 Automatic Identification Systems (AIS) -
 Part 2: Class A shipborne equipment of the automatic identification
 system (AIS) -
 Operational and performance requirements, methods of test and required
 test results
 (IEC 61993-2:2012)**

Matériels et systèmes de navigation et de
 radiocommunications maritimes -
 Systèmes d'identification automatique
 (AIS) -
 Partie 2: Equipements AIS de type Classe
 A embarqués -
 Exigences d'exploitation et de
 fonctionnement, méthodes d'essai et
 résultats d'essai exigés
 (CEI 61993-2:2012)

Navigations- und
 Funkkommunikationsgeräte und -systeme
 für die Seeschifffahrt -
 Automatische
 Identifikationssysteme (AIS) -
 Teil 2: Geräte der Klasse A des
 universellen automatischen
 Identifikationssystems (AIS) für Schiffe -
 Betriebs- und Leistungsanforderungen,
 Prüfverfahren und geforderte
 Prüfergebnisse
 (IEC 61993-2:2012)

This European Standard was approved by CENELEC on 2012-11-23. CENELEC members are bound to comply with the CEN/CENELEC Internal Regulations which stipulate the conditions for giving this European Standard the status of a national standard without any alteration.

Up-to-date lists and bibliographical references concerning such national standards may be obtained on application to the CEN-CENELEC Management Centre or to any CENELEC member.

This European Standard exists in three official versions (English, French, German). A version in any other language made by translation under the responsibility of a CENELEC member into its own language and notified to the CEN-CENELEC Management Centre has the same status as the official versions.

CENELEC members are the national electrotechnical committees of Austria, Belgium, Bulgaria, Croatia, Cyprus, the Czech Republic, Denmark, Estonia, Finland, Former Yugoslav Republic of Macedonia, France, Germany, Greece, Hungary, Iceland, Ireland, Italy, Latvia, Lithuania, Luxembourg, Malta, the Netherlands, Norway, Poland, Portugal, Romania, Slovakia, Slovenia, Spain, Sweden, Switzerland, Turkey and the United Kingdom.

CENELEC

European Committee for Electrotechnical Standardization
 Comité Européen de Normalisation Electrotechnique
 Europäisches Komitee für Elektrotechnische Normung

Management Centre: Avenue Marnix 17, B - 1000 Brussels

Foreword

The text of document 80/656/CDV, future edition 2 of IEC 61993-2, prepared by IEC TC 80 "Maritime navigation and radiocommunication equipment and systems" was submitted to the IEC-CENELEC parallel vote and approved by CENELEC as EN 61993-2:2013.

The following dates are fixed:

- latest date by which the document has to be implemented at national level by publication of an identical national standard or by endorsement (dop) 2013-08-23
- latest date by which the national standards conflicting with the document have to be withdrawn (dow) 2015-11-23

This document supersedes EN 61993-2:2002.

EN 61993-2:2013 includes the following significant technical changes with respect to EN 61993-2:2002:

It incorporates the technical characteristics included in Recommendation ITU-R M.1371-4, which was published in 2010. New technical characteristics result in sundry clarifications to the requirements and the ability to handle five new messages – Messages 23, 24, 25, 26 and 27.

The significant changes in this edition include:

- a new requirement in 6.9 for vessels of type "tanker" to use a low power setting;
- expanded requirements for the functionality of the minimum keyboard and display in 6.11 including new requirements for display of AIS-SART together with an AIS-SART alarm and new requirements for the protection of the static data of the ship;
- expanded requirements for the transmitters and receivers in 7.2 but with the removal of the previous requirement for 12,5 kHz channel operation which has not been used in practice;
- expanded requirements for long-range applications in Clause 8 to add a broadcast method;
- a definition of the pilot plug pin out in 7.6 together with some new requirements for interfaces;
- extensively revised test methods in Clauses 14 to 19 based on the experience of testing AIS equipment;
- expanded test methods in Annex D for DSC functionality but the removal of the previous requirement for DSC polling which is no longer used.

Attention is drawn to the possibility that some of the elements of this document may be the subject of patent rights. CENELEC [and/or CEN] shall not be held responsible for identifying any or all such patent rights.

Endorsement notice

The text of the International Standard IEC 61993-2:2012 was approved by CENELEC as a European Standard without any modification.

In the official version, for Bibliography, the following notes have to be added for the standards indicated:

IEC 61097-14	NOTE	Harmonized as EN 61097-14.
IEC 61108-1	NOTE	Harmonized as EN 61108-1.
IEC 61108-2	NOTE	Harmonized as EN 61108-2.
IEC 61162-3	NOTE	Harmonized as EN 61162-3.
IEC 61162-450	NOTE	Harmonized as EN 61162-450.
IEC 62287-1	NOTE	Harmonized as EN 62287-1.
IEC 62320-1	NOTE	Harmonized as EN 62320-1.
IEC 62320-2	NOTE	Harmonized as EN 62320-2.
ISO 9000 series	NOTE	Harmonized in EN ISO 9000 series.

Annex ZA (normative)

Normative references to international publications with their corresponding European publications

The following documents, in whole or in part, are normatively referenced in this document and are indispensable for its application. For dated references, only the edition cited applies. For undated references, the latest edition of the referenced document (including any amendments) applies.

NOTE When an international publication has been modified by common modifications, indicated by (mod), the relevant EN/HD applies.

<u>Publication</u>	<u>Year</u>	<u>Title</u>	<u>EN/HD</u>	<u>Year</u>
IEC 60945 + corr. April	2002 2008	Maritime navigation and radiocommunication equipment and systems - General requirements - Methods of testing and required test results	EN 60945	2002
IEC 61108	Series	Maritime navigation and radiocommunication equipment and systems - Global navigation satellite systems (GNSS)	EN 61108	Series
IEC 61162-1	-	Maritime navigation and radiocommunication equipment and systems - Digital interfaces - Part 1: Single talker and multiple listeners	EN 61162-1	-
IEC 61162-2	-	Maritime navigation and radiocommunication equipment and systems - Digital interfaces - Part 2: Single talker and multiple listeners, high-speed transmission	EN 61162-2	-
IEC 62288	-	Maritime navigation and radiocommunication equipment and systems - Presentation of navigation-related information on shipborne navigational displays - General requirements, methods of testing and required test results	EN 62288	-
IEC 62388	-	Maritime navigation and radio-communication equipment and systems - Shipborne radar - Performance requirements, methods of testing and required test results	EN 62388	-
IMO Resolution A.694(17)	-	General requirements for shipborne radio equipment forming part of the global maritime distress and safety system (GMDSS) and for electronic navigational aids	-	-
IMO Resolution MSC.74(69)	-	Recommendations on performance standards - for Track control systems	-	-
IMO Resolution MSC.43(64)	-	Guidelines and Criteria for Ship Reporting Systems (as amended by MSC.111(73))	-	-
ITU-R Recommendation M.1371-4	-	Technical characteristics for an automatic identification system using time-division multiple access in the VHF maritime mobile band	-	-
ITU-R Recommendation M.825-3	-	Characteristics of a transponder system using digital selective calling techniques for use with vessel traffic services and ship-to-ship identification	-	-

<u>Publication</u>	<u>Year</u>	<u>Title</u>	<u>EN/HD</u>	<u>Year</u>
ITU-R Recommendation M.493-13	-	Digital selective-calling system for use in the maritime mobile service	-	-
ITU-T Recommendation O.153	-	Basic parameters for the measurement of error performance at bit rates below the primary rate	-	-
ITU-R Recommendation M.1084-5	-	Interim solutions for improved efficiency in the use of the band 156-174 MHz by stations in the maritime mobile service	-	-
ITU-R Recommendation M.541-9	-	Operational procedures for the use of digital selective-calling equipment in the maritime mobile service	-	-

CONTENTS

INTRODUCTION.....	11
1 Scope.....	12
2 Normative references	12
3 Abbreviations	13
4 General requirements.....	14
4.1 General.....	14
4.1.1 Overview	14
4.1.2 General requirements.....	14
4.1.3 Capabilities of the AIS	15
4.1.4 Additional requirements	15
4.1.5 Transmitter shutdown procedure.....	15
4.1.6 Quality assurance.....	15
4.2 Modes of operation.....	15
4.3 Manuals	15
4.4 Marking and identification.....	16
5 Other requirements.....	16
5.1 Environmental, power supply, special purpose and safety requirements	16
5.2 Display of information.....	16
6 Performance requirements	16
6.1 Composition	16
6.2 Time and position.....	17
6.2.1 Source for UTC	17
6.2.2 Source for AIS position reporting	17
6.3 User interface.....	17
6.4 Identification.....	18
6.5 Information	18
6.5.1 Information provided by the AIS.....	18
6.5.2 Information reporting intervals	19
6.5.3 Ship reporting capacity	19
6.6 Event log	20
6.7 Permissible initialization period	20
6.8 Power supply.....	20
6.9 Technical characteristics	20
6.10 Alarms and indications, fall-back arrangements.....	20
6.10.1 Built-in test equipment.....	20
6.10.2 Alarm messages	21
6.10.3 Status messages	23
6.11 Display, input and output.....	26
6.11.1 Minimum keyboard and display (MKD).....	26
6.11.2 Communication test.....	28
6.11.3 Alarms and status information	29
6.11.4 Data protection	29
6.11.5 Distance calculation	29
6.12 Protection from invalid controls	30
7 Technical requirements	30

7.1	General	30
7.2	Physical layer	30
7.2.1	General	31
7.2.2	Transmitter parameters	31
7.2.3	Receiver parameters	32
7.3	Link layer	32
7.3.1	General	32
7.3.2	Link sublayer 1: Medium Access Control (MAC).....	33
7.3.3	Link sublayer 2: Data Link Service (DLS).....	33
7.3.4	Link sublayer 3 – Link Management Entity (LME)	33
7.4	Network layer	35
7.4.1	General	35
7.4.2	Management of regional operating settings	35
7.5	Transport layer	37
7.6	Presentation interface	37
7.6.1	General	37
7.6.2	Automatic input of sensor data	38
7.6.3	High speed input/output ports	38
7.6.4	Long-range communication ports	41
7.6.5	BIIT alarm output.....	43
8	Long-range applications	43
8.1	General	43
8.2	Long-range application by two-way interface	43
8.2.1	General	43
8.2.2	Interrogations and responses	44
8.2.3	Manual and automatic response	44
8.2.4	Data formats and contents.....	44
8.2.5	Addressing AIS-units	44
8.3	Long-range application by broadcast	45
9	Test conditions	45
9.1	Normal and extreme test conditions.....	45
9.1.1	Normal test conditions	45
9.1.2	Extreme test conditions	45
9.2	Standard test environment.....	46
9.3	Additional test arrangements	46
9.3.1	Arrangements for test signals applied to the receiver input	46
9.3.2	Encoder for receiver measurements	46
9.3.3	Waiver for receivers	46
9.3.4	Impedance.....	47
9.3.5	Artificial antenna (dummy load)	47
9.3.6	Facilities for access	47
9.3.7	Modes of operation of the transmitter	47
9.4	Common test conditions for protection from invalid controls	47
9.5	Measurement uncertainties	47
10	Test signals.....	48
10.1	Standard test signal number 1 (DSC)	48
10.2	Standard test signal number 2 (TDMA).....	48
10.3	Standard test signal number 3 (TDMA).....	48
10.4	Standard test signal number 4 (PRBS)	48

10.5	Standard test signal number 5 (PRBS)	48
11	Power supply, special purpose and safety tests	49
12	Environmental tests	49
13	EMC tests	50
14	Operational tests	50
14.1	Identification and operating modes	50
14.1.1	Autonomous mode	50
14.1.2	Assigned mode	51
14.1.3	Polled mode	51
14.1.4	Addressed operation	52
14.1.5	Broadcast operation	52
14.1.6	Multiple slot messages	53
14.2	Information	53
14.2.1	Information provided by the AIS	54
14.2.2	Reporting intervals	54
14.3	Event log	55
14.3.1	Method of measurement	56
14.3.2	Required results	56
14.4	Initialization period	56
14.4.1	Method of measurement	56
14.4.2	Required results	56
14.5	Technical characteristics	56
14.5.1	Channel selection	56
14.5.2	Transceiver protection	57
14.5.3	Automatic power setting	57
14.6	Alarms and indicators, fall-back arrangements	57
14.6.1	Loss of power supply	57
14.6.2	Monitoring of functions and integrity	57
14.6.3	Monitoring of sensor data	59
14.7	Display, input and output	62
14.7.1	Data input/output facilities	62
14.7.2	Initiate message transmission	62
14.7.3	Communication test	63
14.7.4	System control	63
14.7.5	Display of received targets	64
14.7.6	Display of position quality	65
14.7.7	Display of targets if optional filter is implemented	65
14.7.8	Display of received safety related messages	66
14.7.9	Presentation of navigation information	66
15	Physical tests	66
15.1	TDMA transmitter	67
15.1.1	Frequency error	67
15.1.2	Carrier power	67
15.1.3	Slotted transmission spectrum	68
15.1.4	Modulation accuracy	69
15.1.5	Transmitter output power characteristics	69
15.2	TDMA receivers	70
15.2.1	Sensitivity	70

15.2.2	Error behaviour at high input levels	71
15.2.3	Co-channel rejection.....	71
15.2.4	Adjacent channel selectivity.....	72
15.2.5	Spurious response rejection	72
15.2.6	Intermodulation response rejection and blocking	75
15.2.7	Transmit to receive switching time.....	76
15.2.8	Immunity to out-of-band energy	77
15.3	Conducted spurious emissions	77
15.3.1	Spurious emissions from the transmitter	77
15.3.2	Spurious emissions from the receiver	78
16	Specific tests of link layer.....	78
16.1	TDMA synchronisation.....	78
16.1.1	Synchronisation test using UTC.....	78
16.1.2	Synchronisation test using UTC with repeated messages	79
16.1.3	Synchronisation test without UTC, semaphore	79
16.1.4	Synchronisation test without UTC	80
16.1.5	Reception of un-synchronised messages	80
16.2	Time division (frame format).....	80
16.2.1	Method of measurement	80
16.2.2	Required results	80
16.3	Synchronisation and jitter accuracy	81
16.3.1	Definition.....	81
16.3.2	Method of measurement	81
16.3.3	Required results	81
16.4	Data encoding (bit stuffing)	81
16.4.1	Method of measurement	81
16.4.2	Required results	81
16.5	Frame check sequence	81
16.5.1	Method of measurement	81
16.5.2	Required results	81
16.6	Slot allocation (channel access protocols).....	82
16.6.1	Network entry	82
16.6.2	Autonomous scheduled transmissions (SOTDMA)	82
16.6.3	Autonomous scheduled transmissions (ITDMA)	82
16.6.4	Safety related/binary message transmission	83
16.6.5	Transmission of Message 5 (ITDMA)	83
16.6.6	Assigned operation.....	83
16.6.7	Group assignment	84
16.6.8	Fixed allocated transmissions (FATDMA)	88
16.6.9	Randomisation of message transmissions	88
16.7	Message formats.....	88
16.7.1	Received messages	88
16.7.2	Transmitted messages.....	89
17	Specific tests of network layer	89
17.1	Dual channel operation – Alternate transmissions	89
17.1.1	Method of measurement	89
17.1.2	Required results	89
17.2	Regional area designation by VDL message.....	89
17.2.1	Method of measurement	89

17.2.2	Required results	90
17.3	Regional area designation by serial message	90
17.4	Regional area designation with lost position	91
17.4.1	Method of measurement	91
17.4.2	Required results	91
17.5	Power setting	91
17.5.1	Method of measurement	91
17.5.2	Required results	91
17.6	Message priority handling	91
17.6.1	Method of measurement	91
17.6.2	Required results	91
17.7	Slot reuse and FATDMA reservations	91
17.7.1	Method of measurement	91
17.7.2	Required results	92
17.8	Management of received regional operating settings	92
17.8.1	Test for replacement or erasure of dated or remote regional operating settings	92
17.8.2	Test of correct input via presentation interface or MKD	93
17.8.3	Test of addressed telecommand	94
17.8.4	Test for invalid regional operating areas	94
17.9	Continuation of autonomous mode reporting interval	95
17.9.1	Method of test	95
17.9.2	Required results	95
18	Specific tests of transport layer	95
18.1	Addressed messages	95
18.1.1	Transmission	95
18.1.2	Acknowledgement	95
18.1.3	Transmission retry	95
18.1.4	Acknowledgement of addressed safety related messages	96
18.1.5	Behaviour of NavStatus 14 reception	96
18.2	Interrogation responses	96
18.2.1	Method of measurement	96
18.2.2	Required results	96
19	Specific presentation interface tests	97
19.1	General	97
19.2	Checking manufacturer's documentation	97
19.3	Electrical test	97
19.3.1	Method of test	97
19.3.2	Required results	97
19.4	Test of input sensor interface performance	97
19.4.1	Method of measurement	97
19.4.2	Required results	98
19.5	Test of sensor input	98
19.5.1	Test of GNS input	98
19.5.2	Test of RMC input	98
19.5.3	Test of DTM input	99
19.5.4	Test of GBS input	99
19.5.5	Test of VBW input	100
19.5.6	Test of VTG input	100

19.5.7	Test of HDT/THS input	101
19.5.8	Test of ROT input	101
19.5.9	Test of different inputs	102
19.5.10	Test of multiple inputs	102
19.6	Test of high speed output	103
19.6.1	Method of measurement	103
19.6.2	Required results	103
19.7	High speed output interface performance	103
19.7.1	Method of measurement	103
19.7.2	Required results	103
19.8	Output of undefined VDL messages	103
19.8.1	Method of measurement	103
19.8.2	Required results	103
19.9	Test of high speed input	103
19.9.1	Method of measurement	103
19.9.2	Required results	104
20	Long-range functionality tests	104
20.1	Long-range application by two-way interface	104
20.1.1	LR interrogation	104
20.1.2	LR "all ships" interrogation	104
20.1.3	Consecutive LR "all ships" interrogations	105
20.2	Long-range application by broadcast	105
20.2.1	Long-range broadcast	105
20.2.2	Multiple assignment operation	106
Annex A (informative)	Block diagram of AIS	108
Annex B (normative)	AIS interface overview (see Table 13)	109
Annex C (informative)	Block diagram of standard test environment	110
Annex D (normative)	DSC functionality	111
Annex E (informative)	Optional PI port sentences	117
Annex F (informative)	Alarm handling	121
Annex G (normative)	Calculation of area size and distance	122
Annex H (normative)	Transmission of binary Messages 25 and 26	125
Bibliography	129
Figure 1	– OSI layer model	30
Figure 2	– Power versus time characteristics	31
Figure 3	– Format for repeating four-packet cluster	48
Figure 4	– Measurement arrangement for frequency error	67
Figure 5	– Measurement arrangement for carrier power	67
Figure 6	– Emission mask for slotted transmission	68
Figure 7	– Measurement arrangement for modulation accuracy	69
Figure 8	– Measurement arrangement	70
Figure 9	– Measurement arrangement with two generators	71
Figure 10	– SINAD or PER/BER measuring equipment	74
Figure 11	– Test set-up	75
Figure 12	– Transmit to receive switching time measurement setup	76

Figure 13 – Regional area scenario	90
Figure D.1 – Measurement arrangement for inter-modulation	114
Table 1 – Information reporting intervals for autonomous mode	19
Table 2 – Integrity alarm conditions signalled using ALR sentence formatter	22
Table 3 – Sensor status indications signalled using TXT sentence formatter	23
Table 4 – Position sensor fallback conditions	24
Table 5 – Use of accuracy (PA) flag	25
Table 6 – ROT sensor fallback conditions	26
Table 7 – Message display on MKD	27
Table 8 – Position quality	28
Table 9 – Transmitter parameters	31
Table 10 – Power versus time characteristics	32
Table 11 – Receiver parameters	32
Table 12 – Use of VDL messages	33
Table 13 – Presentation interface access	37
Table 14 – IEC 61162-1 sensor sentences	38
Table 15 – AIS High-speed input data and formats	39
Table 16 – AIS high-speed output data and formats	40
Table 17 – AIS Long-range communications input data and formats	42
Table 18 – LR output data formats	43
Table 19 – LR data types	44
Table 20 – Content of first two packets	49
Table 21 – Fixed PRS data derived from Recommendation ITU-T O.153	49
Table 22 – Peak frequency deviation versus time	69
Table 23 – Tests to be performed	76
Table 24 – Primary channels for each region	90
Table E.1 – Property identifier	118
Table G.1 – Coordinate points	122

INTRODUCTION

In comparison with the previous edition of this Standard, the structural changes to the document are that the original Clause 8 on DSC compatibility together with the corresponding tests in Clause 20 have been moved into a new Annex D. A new Clause on test signals has been added as Clause 10. The original Annex B detailing IEC 61162 sentences has been deleted and replaced with a new Annex H, noting that much of this information is now included in IEC 61162-1. The original Annex C describing long-range applications has also been deleted as IMO has decided to adopt a different system for long-range identification and tracking. A new Annex E has been added to describe optional presentation interface port sentences, a new Annex F has been added on alarm handling and a new Annex G has been added on calculation of area size and distance.

MARITIME NAVIGATION AND RADIOCOMMUNICATION EQUIPMENT AND SYSTEMS – AUTOMATIC IDENTIFICATION SYSTEMS (AIS)

Part 2: Class A shipborne equipment of the automatic identification system (AIS) – Operational and performance requirements, methods of test and required test results

1 Scope

This part of IEC 61993 specifies the minimum operational and performance requirements, methods of testing and required test results conforming to performance standards adopted by the IMO in Resolution MSC.74(69), Annex 3, Shipborne Automatic Identification System. This standard incorporates the applicable technical characteristics of Class A shipborne equipment included in Recommendation ITU-R M.1371-4 and takes into account the ITU Radio Regulations, where applicable. In addition, it takes account of IMO Resolution A.694(17) to which IEC 60945 is associated. When a requirement in this standard is different from IEC 60945, the requirement of this standard takes precedence.

This part of IEC 61993 also specifies the minimum requirements both for the means to input and display data and for the interfaces to other equipment suitable to be used as means of input and display data.

NOTE All text of this standard, that is identical to that in IMO resolution MSC.74(69), Annex 3 or to that in ITU-R Recommendation M.1371-4 is printed in *italics* and references to the resolution (abbreviated to "A3") or the recommendation (abbreviated to "M.1371") and paragraph numbers are indicated in parentheses, for instance (A3/3.3) or (M.1371/A2-3.3) respectively.

2 Normative references

The following documents, in whole or in part, are normatively referenced in this document and are indispensable for its application. For dated references, only the edition cited applies. For undated references, the latest edition of the referenced document (including any amendments) applies.

IEC 60945:2002, *Maritime navigation and radiocommunication equipment and systems – General requirements – Methods of testing and required test results*

IEC 61108 (all parts), *Maritime navigation and radiocommunication equipment and systems – Global navigation satellite systems (GNSS)*

IEC 61162-1, *Maritime navigation and radiocommunication equipment and systems – Digital interfaces – Part 1: Single talker and multiple listeners*

IEC 61162-2, *Maritime navigation and radiocommunication equipment and systems – Digital interfaces – Part 2: Single talker and multiple listeners, high-speed transmission*

IEC 62288, *Maritime navigation and radiocommunication equipment and systems – Presentation of navigation-related information on shipborne navigational displays – General requirements, methods of testing and required test results*

IEC 62388, *Maritime navigation and radiocommunication equipment and systems – Shipborne radar – Performance requirements, methods of testing and required test results*

IMO Resolution A.694(17), *General requirements for shipborne radio equipment forming part of the Global Maritime Distress and Safety System (GMDSS) and for electronic navigational aids*

IMO Resolution MSC.43(64), as amended by MSC.111(73), *Guidelines and Criteria for Ship Reporting Systems*

IMO Resolution MSC.74(69) Annex 3, *Recommendation on performance standards for AIS*

ITU-R Recommendation M.493-13, *Digital selective-calling system for the use in the maritime mobile service*

ITU-R Recommendation M.541-9, *Operational procedures for the use of digital selective-calling (DSC) equipment in the maritime mobile service*

ITU-R Recommendation M.825-3, *Characteristics of a transponder system using digital selective calling techniques for use with vessel traffic services and ship-to-ship identification*

ITU-R Recommendation M.1084-5, *Interim solutions for improved efficiency in the use of the band 156-174 MHz by stations in the maritime mobile service*

ITU-R Recommendation M.1371-4, *Technical characteristics for an automatic identification system using time division multiple access in the VHF maritime mobile band*

ITU-T Recommendation O.153, *Basic parameters for the measurement of error performance at bit rates below the primary rate*

3 Abbreviations

AIS	automatic identification system
AIS-SART	AIS search and rescue transmitter
BIIT	built-in integrity tests
BT	bandwidth-time
COG	course over ground
CommState	communication state (see NOTE 1)

NOTE 1 Communication state is defined in Recommendation ITU-R M.1371-4. It is used to indicate whether the AIS is using the message structure for SOTDMA or ITDMA.

ECDIS	electronic chart display and information system
EPFS	electronic position-fixing systems
ETA	estimated time of arrival
EUT	equipment under test
FATDMA	fixed access time division multiple access
GMSK	Gaussian minimum shift keying
HDG	Heading
IMO	International Maritime Organization
ITDMA	incremental time division multiple access
LR	long-range
MAC	medium access control
MKD	minimum keyboard and display
MMSI	maritime mobile service identity

NavStatus navigational status (see NOTE 2)

NOTE 2 Navigational status is defined in Recommendation ITU-R M.1371-4. It consists of information that may be input by the ship's crew to indicate whether the ship is underway, moored, etc.

NSS	nominal start slot
NTS	nominal transmission slot
NUC	not under command
PC	performance check
PER	packet error rate
PI	presentation interface
PT	performance test
RAIM	receiver autonomous integrity monitoring
RATDMA	random access time division multiple access
RF	radio frequency
ROT	rate of turn
SI	selection interval
SOG	speed over ground
SOTDMA	self organizing time division multiple access
UTC	universal time co-ordinated
VDL	VHF data link
VSWR	voltage standing wave ratio
Rx	Receive
Tx	Transmit

NOTE 3 Abbreviations related to IEC 61162-1 are not included in the above list. For their meanings refer to that standard.

4 General requirements

4.1 General

4.1.1 Overview

Requirements contained in this clause are requirements not taken up in other clauses and are verified by observation and inspection of documented evidence. These requirements include the applicable general and operational requirements of IEC 60945:2002, as detailed in Clause 6 (Operational checks), Clause 13 (Maintenance), Clause 14 (Equipment manuals) and Clause 15 (Marking and identification).

The manufacturer shall declare compliance with these requirements and shall provide relevant documentation. The declarations, documentation and, where necessary, the EUT shall be checked or verified by inspection.

The manufacturer shall also declare the composition of the EUT and the category for durability and resistance to environmental conditions for each unit of the EUT as specified in IEC 60945.

4.1.2 General requirements

(A3/1.1) *This standard specifies the requirements for the AIS.*

(A3/1.2) *The AIS shall improve the safety of navigation by assisting in the efficient navigation of ships, protection of the environment, and operation of Vessel Traffic Services (VTS), by satisfying the following functional requirements:*

- *in a ship-to-ship mode for collision avoidance;*
- *as a means for littoral States to obtain information about a ship and its cargo; and*
- *as a VTS tool, i.e. ship-to-shore (traffic management).*

4.1.3 Capabilities of the AIS

(A3/1.3) *The AIS shall be capable of providing to ships and to competent authorities, information from the ship, automatically and with the required accuracy and frequency, to facilitate accurate tracking. Transmission of the data shall be with the minimum involvement of ship's personnel and with a high level of availability.*

4.1.4 Additional requirements

(A3/1.4) *The installation, in addition to meeting the requirements of the Radio Regulations, applicable ITU-R Recommendations and the general requirements as set out in resolution A.694 (17), shall comply with the following performance standards, as contained in the following clauses.*

4.1.5 Transmitter shutdown procedure

(M.1371/A2-2.13) *An automatic transmitter hardware shutdown procedure and indication shall be provided in case a transmitter continues to transmit for more than 2 s. This shutdown procedure shall be independent of software control.*

4.1.6 Quality assurance

The Administration shall require that the manufacturers have a quality control system audited by a competent authority to ensure continuous compliance with the type approval conditions. Alternatively, the Administration may use final product verification procedures where a competent authority verifies compliance with the type approval certificate before the product is installed on board ships.

NOTE The ISO 9000 series, as applicable, meets this requirement.

4.2 Modes of operation

(A3/2.1) *The system shall be capable of operating in a number of modes:*

- 1) *an "autonomous and continuous" mode for operation in all areas. This mode shall be capable of being switched to/from one of the following alternate modes by a competent authority;*
- 2) *an "assigned" mode for operation in an area subject to a competent authority responsible for traffic monitoring such that the data transmission interval and/or time slots may be set remotely by that authority;*
- 3) *a "polling" or controlled mode where the data transfer occurs in response to interrogation from a ship or competent authority.*

The Class A AIS shall be capable to receive and process DSC channel management telecommands conforming to the provisions of Recommendations ITU-R M.493, ITU-R M.541, ITU-R M.825 (see Annex D).

4.3 Manuals

In addition to the requirements of IEC 60945:2002, Clause 14, the manuals shall include:

- the type and details of all external connectors (including the pilot plug) referred to in 7.6

- the needed information for correct siting of the antennas; and
- the requirements for external illumination, as appropriate.

4.4 Marking and identification

In addition to the requirements of IEC 60945:2002, Clause 15, the markings shall include:

- details of the power supply from which the equipment is intended to be operated; and,
- if applicable, the date by which batteries need to be replaced.

5 Other requirements

5.1 Environmental, power supply, special purpose and safety requirements

The AIS shall be tested for compliance with the environmental, power supply, special-purpose and safety requirements of IMO A.694(17) as detailed in IEC 60945. The required tests, for which a repeatable method of measurement has been defined, are given in Clauses 11, 12 and 13 of this standard. The declaration of category to IEC 60945:2002 Clause 4, shall define the relevant tests to be applied as follows:

- AIS equipment declared for protected installation shall meet the requirements described in Table 3 column "protected" of IEC 60945:2002;
- exposed AIS equipment shall meet the requirements described in Table 3 column "exposed" of IEC 60945:2002;
- portable AIS equipment shall meet the requirements of Table 3 of IEC 60945:2002 "protected" or "exposed" as appropriate.

5.2 Display of information

The AIS shall be tested as applicable against the requirements for presentation of information contained in IEC 62288 (see 14.7.9).

6 Performance requirements

6.1 Composition

(A3/3.1) *The AIS shall comprise (see Annex A):*

- 1) *a communication processor, capable of operating over a range of maritime frequencies, with an appropriate channel selecting and switching method, in support of both short (VHF) and long (beyond VHF) range applications. For long-range applications the AIS shall provide a two-way interface (see 7.6.4);*
- 2) *at least one transmitter, two TDMA receiving processes and one dedicated continuous DSC receiving process tuned to channel 70;*
- 3) *a means of processing data from an electronic position-fixing system which provides a resolution of one ten thousandth of a minute of arc and uses the WGS 84 datum.*

An interface (see 7.6.2) shall be provided to input the position used for navigation. Position information, if available from other EPFS, shall be used only as a back up and the user shall be informed of this (see 6.10).

- 4) *a means to automatically input data from other sensors meeting the provisions as specified in 6.5.1 point 2); a means, external to the AIS, to comply with this requirement shall be tested to the applicable requirements of IEC 60945.*
- 5) *a means to input and retrieve data manually. The possibility of manual input and retrieval as described in 6.11 shall be demonstrated based on the manufacturer's documentation.*
- 6) *a means of error checking the transmitted and received data (see Clause 7); and*
- 7) *built-in test equipment (BIIT) as specified in 6.10.1.*

(A3/3.2) *The AIS shall be capable of:*

- 1) *providing information automatically and continuously to a competent authority and other ships, without involvement of ship's personnel;*
- 2) *receiving and processing information from other sources, including that from a competent authority and from other ships;*
- 3) *responding to high priority and safety related calls with a minimum of delay;*
- 4) *providing positional and manoeuvring information at a data rate adequate to facilitate accurate tracking by a competent authority and other ships. (See 6.5.2).*

6.2 Time and position

6.2.1 Source for UTC

The AIS shall be provided with an internal GNSS receiver as primary UTC source which is required for synchronisation purposes and for fall back position, COG and SOG.

NOTE UTC includes a provision for leap seconds.

The internal GNSS receiver shall meet the following requirements of the IEC 61108 series: position accuracy, COG / SOG, acquisition, re-acquisition, receiver sensitivity, RF dynamic range, interference susceptibility, position update, failure warnings, status indications and integrity flag.

NOTE IMO Resolution MSC.74(69), Annex 3 requires the AIS to have a means of processing data from an electronic position fixing system that provides a resolution of one ten-thousandth of a minute of arc and uses the WGS 84 datum (see 6.1).

If the manufacturer intends to use the internal GNSS as the ship's position source, the internal GNSS receiver shall be type approved in accordance with IEC 61108 under the highest load condition of the AIS processor and the sentences DTM, GNS, GBS, and RMC shall be output on a dedicated port.

If date and time from the internal GNSS is not available and Message 4 or 11 is being received, the unit shall use date and time from that message, the seconds shall be omitted.

6.2.2 Source for AIS position reporting

The source for position reporting may vary depending on the conditions specified in 6.10.3.5.

When the external position is unavailable, the internal GNSS receiver may be used as a source for AIS position reporting.

When the internal GNSS receiver is performing as a source for AIS position reporting

- an appropriate BIIT indication shall be output on the presentation interface (see 6.10.1),
- the position data shall be available on the minimum keyboard and display (see 6.11.1),
- the internal GNSS receiver shall be capable of being differentially corrected, at least by evaluation of Message 17.

Where DGNS corrections are received from multiple sources, the DGNS corrections from the nearest DGNS reference station should be used taking into account the Z count, and the health of the DGNS reference station.

6.3 User interface

(A3/4) *To enable a user to access, select and display the information on a separate system, the AIS shall be provided with an interface conforming to an appropriate international marine interface standard.*

All interfacing shall be made via the system interface as described in 7.6 (called the presentation interface).

6.4 Identification

(See 14.1)

(A3/5) *For the purpose of ship and message identification, the appropriate Maritime Mobile Service Identity (MMSI) number shall be used.*

The unit shall be supplied with a default MMSI of “000000000” (this is not a valid MMSI).

The unit shall check that any programmed MMSI is between 200000000 and 799999999 or between 982000000 and 987999999 otherwise the unit shall reject the programming and be not capable of transmitting. However a reset to the default value “000000000” shall be accepted, but the unit shall not be capable to transmit with this MMSI.

6.5 Information

(See 14.2)

6.5.1 Information provided by the AIS

(A3/6.1) *The information provided by the AIS shall include:*

1) *Static:*

- *IMO number (where available)*
- *Call sign & name*
- *Length and beam*
- *Type of ship*
- *Location of the in use position-fixing antenna on the ship (aft of bow and port or starboard of centreline)*

Static information and the MMSI shall be stored in non-volatile memory devices.

2) *Dynamic:*

- *Ship's position referenced to WGS 84 datum with accuracy indication and integrity status*
- *Time in UTC, the date is established by the receiving equipment*
- *Course over ground (COG)*
- *Speed over ground (SOG)*
- *Heading.*
- *Navigational status (e.g. not under command (NUC), at anchor, etc.- manual input)*
- *Rate of turn (where available)*

3) *Voyage related:*

- *Ship's draught*
- *Hazardous cargo (type; as required by a competent authority)*
- *Destination and estimated time of arrival (ETA) (at master's discretion)*

4) *Short safety-related messages*

However pre-configured safety related messages (for example with “MAYDAY”, “DISTRESS” and distress communication text) shall not be provided.

NOTE IMO COMSAR.1/Circ.46 of February 2009 advises that short safety-related messages are not incorporated in AIS equipment because there is no SAR infrastructure in place to accommodate them.

6.5.2 Information reporting intervals

(A3/6.2) *The different information types are valid for a different time period and thus need a different reporting interval.*

Static information: Every 6 min, when data has been amended, and on request.

Dynamic Information: Dependent on speed and course alteration according to Table 1
Every 3 min for long range broadcast message (see 8.3).

Voyage related information: Every 6 min, when data has been amended, and on request

Safety-related message: As required

NOTE An SSD or VSD sentence that does not amend the data does not generate a transmission of Message 5.

Table 1 – Information reporting intervals for autonomous mode

<i>Type of Ship</i>	<i>Reporting interval</i>	
<i>Ship at anchor or moored and not moving faster than 3 knots</i>	3	<i>min</i>
<i>Ship at anchor or moored and moving faster than 3 knots</i>	10	s
<i>Ship with a speed of between 0 – 14 knots (default)</i>	10	s
<i>Ship with a speed of between 0 – 14 knots and changing course ^a</i>	3 1/3	s
<i>Ship with a speed of between 14 – 23 knots</i>	6	s
<i>Ship with a speed of between 14 – 23 knots and changing course</i>	2	s
<i>Ship with a speed of greater than 23 knots</i>	2	s
<i>Ship with a speed of greater than 23 knots and changing course</i>	2	s
a Indicated by a change in ship's heading.		

(M.1371/A1-4.2.1) *The reporting interval shall decrease to 2 s when the station determines that it is the semaphore.*

If the autonomous mode requires a shorter reporting interval than the assigned mode, the AIS shall use the autonomous mode reporting interval.

When transmitting on a single channel, the reporting interval shall be maintained by doubling the number of transmissions on the active channel.

When NavStatus is “at anchor”, “moored” or “aground” and the vessel is moving faster than 3 kn alarm ID 10 (see Table 2) should be generated; the reporting interval shall be in accordance with Table 1.

When NavStatus is under way and SOG is less than 1 kn for more than 2 h, alarm ID 10 should be generated.

6.5.3 Ship reporting capacity

(A3/6.2) *The system shall be able to handle a minimum of 2 000 reports per minute, to adequately provide for all operational scenarios envisioned.*

However, the AIS mobile unit shall be capable of processing of all messages on the VDL.

6.6 Event log

(See 14.3)

(A3/6.3) A security mechanism shall be provided to detect disabling of the AIS and to prevent unauthorised alteration of input or transmitted data. To protect the unauthorised dissemination of data, the IMO guidelines (IMO Resolution MSC.43(64), Guidelines for Ship Reporting Systems) shall be followed.

Means shall be provided to automatically record all periods when the AIS installation is nonfunctioning, for instance when the power is switched off, when the AIS is in receive only mode or not transmitting for other reasons, as follows.

The last 10 times when the equipment was non-functioning for more than 15 min shall be recorded, in UTC time and duration, in a non-volatile memory. Means shall be provided to recover this data. It shall not be possible for the user to alter any information recorded in this memory.

6.7 Permissible initialization period

(See 14.4)

(A3/7) The installation shall be operational within 2 min of switching on.

NOTE Sensors used with the AIS meet the requirements of their individual product standards (for example – IEC 61108-1 for GPS which permits 30 min to operation when there is no valid almanac data available, or IEC 61108-2 for GLONASS).

6.8 Power supply

(A3/8) The AIS and associated sensors shall be powered from the ship's main source of electrical energy. In addition, it shall be possible to operate the AIS and associated sensors from an alternative source of electrical energy.

6.9 Technical characteristics

(See 14.5)

(A3/9) The technical characteristics of the AIS such as variable transmitter output power, operating frequencies (dedicated internationally and selected regionally), modulation, and antenna system shall comply with the appropriate ITU-R Recommendations.

Additionally, there shall be a low power setting of 1 W which is automatically adopted when the vessel type is a “tanker” and the NavStatus is “moored” and not moving faster than 3 kn. This is to facilitate low power operation when loading and unloading.

There shall be an indication to the user when the low power setting is in operation.

6.10 Alarms and indications, fall-back arrangements

(See 14.6)

6.10.1 Built-in test equipment

The AIS shall be equipped with BIIT. These tests shall run continuously or at appropriate intervals simultaneously with the standard functions of the equipment.

If any failure or malfunction is detected that will significantly reduce integrity or stop operation of the AIS, an alarm is initiated. In this case (see Annex F)

- the alarm shall be displayed on the MKD,
- the alarm relay shall be set "active",
- an appropriate alarm message shall be output via the presentation interface upon occurrence and repeated every 30 s.

If a change of a relevant system status as described below is detected, an indication is given to the user. In this case

- the indication shall be accessible on the MKD,
- an appropriate TXT sentence shall be output via the presentation interface.

6.10.2 Alarm messages

6.10.2.1 Using the ALR formatter

An ALR-sentence is used to indicate a failure or malfunction that will significantly reduce integrity or stop operation of the AIS.

Alarm messages shall be IEC 61162-1 compliant "\$AIALR"-sentences on the presentation interface output port.

The following parameters of this sentence formatter:

- time of alarm condition change (UTC);
- unique alarm number (identifier) at alarm source;
- alarm condition;
- alarm's acknowledge state;
- alarm's description text;

shall be set according to Table 2.

The "alarm condition" field shall be set to "A" when the alarm condition threshold is exceeded, and "V" when the alarm condition returns to a level that does not exceed the threshold. During healthy conditions (no alarm condition) an empty ALR sentence shall be sent at one-minute intervals.

The acknowledged state flag shall be set after acknowledgement of an alarm internally by means of the MKD or externally by a corresponding ACK sentence.

The local alarm identifiers (alarm ID) given in Table 2 are defined for the use with formatters ALR, ACK, and as text identifiers in TXT sentences to link associated messages. ALR-sentences with "alarm numbers" greater than 099 cannot be followed by TXT-sentences containing additional information by using the TXT-sentence's "text identifier". The "text identifier" is limited to the range of 01 to 99.

Additional numbers may be used by the manufacturer for other purposes but shall be in the range 051 to 099.

6.10.2.2 Monitoring of functions and integrity

In case a failure is detected in one or more of the following functions or data, an alarm shall be triggered and the system shall react as given in Table 2.

Table 2 – Integrity alarm conditions signalled using ALR sentence formatter

Alarm's description text	Alarm condition threshold exceeded	Alarm condition not exceeded	Alarm ID or Text Identifier	Reaction of the system to the alarm condition threshold exceeded
AIS: Tx malfunction	A	V	001	Stop transmission
AIS: Antenna VSWR exceeds limit	A	V	002	Continue operation
AIS: Rx channel 1 malfunction	A	V	003	Stop transmission on affected channel
AIS: Rx channel 2 malfunction	A	V	004	Stop transmission on affected channel
AIS: Rx channel 70 malfunction	A	V	005	Continue operation
AIS: general failure	A	V	006	Stop transmission
AIS: UTC sync invalid	A	V	007	Continue operation using indirect or semaphore synchronisation
AIS: MKD connection lost	A	V	008	Continue operation with "DTE" set to "1" ^a
AIS: internal / external GNSS position mismatch	A	V	009	Continue operation
AIS: NavStatus incorrect	A	V	010	Continue operation
Heading sensor offset	A	V	011	Continue operation
AIS: active AIS-SART	A	V	014	Continue operation
AIS: external EPFS lost	A	V	025	Continue operation (refer to Table 4)
AIS: no position sensor in use	A	V	026	Continue operation (refer to Table 4, priority 6)
AIS: no valid SOG information	A	V	029	Continue operation using default data
AIS: no valid COG information	A	V	030	Continue operation using default data
AIS: Heading lost/invalid	A	V	032	Continue operation using default data b
AIS: no valid ROT information	A	V	035	Continue operation using default data b
^a Applicable if MKD is only means of display.				
^b When so configured.				

Alarm ID 001 shall be activated when

- the integrity of the VDL would be degraded by incorrect transmitter behaviour (for instance in case of the Tx shutdown procedure has operated),
- the unit is not able to transmit for technical reasons or missing or invalid MMSI.

Alarm ID 11 shall be activated when SOG is greater than 5 kn and the difference between COG and HDT is greater than 45° for 5 min.

6.10.2.3 Alarm relay output

A normally closed (NC) earth free relay contact shall be provided as an independent and simple method for triggering an external alarm.

The alarm relay shall be “active” in case of power “off”.

The alarm relay shall be deactivated upon acknowledgement of an alarm either internally by means of minimum display and keyboard or externally by a corresponding ACK sentence.

6.10.3 Status messages

6.10.3.1 General

If any significant change in system operation occurs, but overall system operation is not affected, an indication is initiated. A TXT-sentence is used to indicate when such a significant change in system operation occurs.

6.10.3.2 Using the TXT formatter

Status messages shall be IEC 61162-1 compliant "\$AITXT"-sentences on the presentation interface output port. Status messages do not activate the alarm relay and do not require an acknowledgement.

The parameters of this sentence formatter

- Text identifier, and
- Text message

shall be set according to Table 3.

It shall be possible to monitor the current sensor status by means of a query sentence \$xxAIQ,TXT.

6.10.3.3 Channel management parameters changed

The TXT-sentence, Text Identifier 036, shall be followed by the appropriate ACA sentence(s) to report the affected AIS conditions.

The TXT and ACA sentence pair shall be transmitted only once when crossing the boundary of the region, when the parameters in use are changed by a new command or on request (\$xxAIQ,ACA).

6.10.3.4 Monitoring sensor data status

Indications shall be given and the system shall react as given in Table 3.

Table 3 – Sensor status indications signalled using TXT sentence formatter

Text Message	Text Identifier	Reaction of the system
AIS: external DGNSS in use	021	Continue operation
AIS: external GNSS in use	022	Continue operation
AIS: internal DGNSS in use (beacon)	023	Continue operation
AIS: internal DGNSS in use (Message 17)	024	Continue operation
AIS: internal GNSS in use	025	Continue operation
AIS: external SOG/ COG in use	027	Continue operation
AIS: internal SOG/ COG in use	028	Continue operation
AIS: Heading valid	031	Continue operation
AIS: Rate of Turn Indicator in use	033	Continue operation
AIS: Other ROT source in use	034	Continue operation
AIS: Channel management parameters changed	036	Continue operation

6.10.3.5 Position sensor fallback conditions

Priorities and affected position report data shall be as in Table 4.

Table 4 – Position sensor fallback conditions

Priority	Affected data in Message 1, 2, 3 ⇒				
	Position Sensor status	Position accuracy flag	Time stamp	RAIM flag	Position Latitude/Longitude
1	External DGNSS in use (corrected) ^a	1	UTC-s	1/ 0 *	Lat/Lon (external)
2	Internal DGNSS in use (corrected; Message 17)	1	UTC-s	1/ 0 *	Lat/Lon (internal)
3	Internal DGNSS in use (corrected; beacon) ^b	1	UTC-s	1/ 0 *	Lat/Lon (internal)
4	External EPFS in use (uncorrected) ^a	0	UTC-s	1/ 0 *	Lat/Lon (external)
5	Internal GNSS in use (uncorrected)	0	UTC-s	1/ 0 *	Lat/Lon (internal)
6	Dead reckoning position (from the external EPFS in use)	0	62	0	Lat/Lon (dead-reckon)
	Manual position input (from the external EPFS in use)		61		Lat/Lon (manual)
	No position		63		not available = 91/181

^a Applicable in all configurations (minimum requirement).

^b Applicable only if (optionally) an internal beacon receiver is provided. * if RAIM available “1”; if not, default “0”.

The AIS shall automatically select the position source with the highest priority available. If data availability changes, the AIS shall automatically switch to the position source with the highest priority available after 5 s when switching downwards or 30 s when switching upwards. During this period, the latest valid position shall be used for reporting.

When the external position source is used and both external and internal positions are valid then the external and internal positions shall be compared once per minute and an alarm generated if the difference between the two positions is greater than 100 m + distance between the two GNSS antennas, for a period of 15 min.

If the valid position does not have a timestamp (time stamp not available = 60) transmit the position report with time stamp set to 60.

On changeover from one status to another a new Message 5 shall be transmitted immediately when the reference point for the reported position has changed and an “ALR” sentence as described above shall be output to the presentation interface.

If RAIM is available (indicated by a valid GBS sentence or equivalent information), the position accuracy flag shall be evaluated using Table 5.

Table 5 – Use of accuracy (PA) flag

Accuracy status from RAIM (for 95 % of position fixes)	RAIM flag	Differential correction status	Resulting value of position accuracy (PA) flag
No RAIM process available	0	Uncorrected	0 = low (> 10 m)
Expected error is < =10 m	1		1 = high (< =10 m)
Expected error is > 10 m	1		0 = low (> 10 m)
No RAIM process available	0	Corrected	1 = high (< =10 m)
Expected error is < =10 m	1		1 = high (< =10 m)
Expected error is > 10 m	1		0 = low (> 10 m)

The connected GNSS receiver indicates the availability of a RAIM process by a valid GBS sentence of IEC 61162-1. In this case the RAIM-flag shall be set to “1”. The position accuracy threshold for evaluation of the RAIM information is 10 m. The RAIM expected error is calculated based on the GBS parameters “expected error in latitude” and “expected error in longitude” using the following formula:

$$\text{Expected RAIM error} = \sqrt{(\text{expected error in latitude})^2 + (\text{expected error in longitude})^2}$$

The mode indicator in the position sentences of IEC 61162-1 received from the connected position sensor indicates the correction status.

6.10.3.6 SOG/ COG sensor fallback conditions

SOG/COG information from the internal GNSS receiver shall be used, if this internal GNSS receiver is in use as a position source. This is to avoid transmission of information referenced to different points on the ship.

6.10.3.7 ROT sensor fallback conditions

The AIS shall automatically select the ROT source with the highest priority available as given in Table 6.

ROT data shall not be derived from COG information.

Table 6 – ROT sensor fallback conditions

Priority	Affected data in Message 1, 2, 3 ⇒	
	Position sensor status	Contents of ROT field
1	Rate of turn indicator in use ^a	0...+126 = turning right at up to 708°/min or higher; 0...-126 = turning left at up to 708°/min or higher. Values between 0° and 708°/min shall be coded by $ROT_{AIS} = 4,733 \text{ SQRT}(ROT_{sensor})^{\circ}/\text{min}$ where ROT_{sensor} is the rate of turn as input by the external rate of turn indicator (TI). Values of 709°/min and above shall be cut to 708°/min
2	Other ROT source in use ^b	+127 = turning right at more than 5°/30 s (No TI available) -127 = turning Left at more than 5°/30 s (No TI available)
3	No valid ROT information available	-128 (80 hex) indicates no turn information available (default)

^a Rate of turn indicator according to IMO A.526(13); determined by talker ID.

^b i.e. based on HDG information.

6.11 Display, input and output

(See 14.7)

6.11.1 Minimum keyboard and display (MKD)

The MKD is an essential part of the AIS and it may be remote. If the MKD is remote then a facility shall be provided to ensure the integrity of the link using a HBT sentence.

The MKD is a display and manual input device to allow the following functions.

- Manual input of voyage related and static ship data and safety related messages, control of AIS and data selection. The method of entering the navigational status and voyage related data shall be readily available to the operator. It shall not be possible to input the Navigational status 14 by the Class A AIS station.
- Display of own ship transmitted static, dynamic and voyage related data.
- Display a minimum of 200 targets.
- Display at least three (3) lines of target data. Each line to display at least bearing, range, name of ship and time elapsed since last position report received. Range to SAR Aircraft shall be 2-dimensional. Horizontal scrolling of bearing and range and time elapsed is not allowed. The title of display data shall be visible.

By default the target list is auto-sorted in ascending range except the nearest active AIS-SART or, if supported, other targets of interest shall be displayed at the top of the list.

The time out value for target display, other than AIS-SART, shall be 7 min. For SART ACTIVE the time out value shall be 18 min. The time out value for storing the target data shall be 18 min.

It may be possible to filter the presentation of AIS targets (for example, by target range, CPA/TCPA or AIS target class A/B, etc.). If additional filtering or grouping is supported the manufacturer should document this functionality as an option. If display equipment provides facilities for the calculation of CPA/TCPA then the facilities should comply with the relevant Clauses of IEC 62388. If a filter is applied, then there shall be a clear and permanent or persistent indication for the application, as appropriate. The filter criteria in use shall be readily available to the user.

It shall not be possible to remove individual AIS targets from the presentation.

The active AIS-SARTs shall be displayed on the top of the target list. The testing (including type approval testing) AIS-SART should not be displayed or output on the PI during normal operation; however the AIS should have the capability to display and output on the PI the testing AIS-SART during periodical testing of own ship's AIS-SART.

The active and testing AIS-SART should be identified as follows:

- Active AIS-SART: confirm that user IDs of Message 1 lead with 97, Message 1 NavStatus is 14.
- Testing AIS-SART: confirm that user IDs of Messages 1 and 14 lead with 97, Message 1 NavStatus is 15, Message 14 text is "SART TEST".
- Type approval testing AIS-SART: confirm that user IDs of Messages 1 and 14 lead with 97000, Message 1 NavStatus is 15 and Message 14 text is "SART TEST".

NOTE All equipment utilizing user IDs with leading 97 and NavStatus 14 will be identified as active AIS-SART equipment.

The DTE flag (refer to Recommendation ITU-R M.1371-4/A8-3.3) shall only be set to "1" when there is no means of displaying received text messages. External equipment indicates the availability of a remote MKD functionality by a HBT sentence sent every 30 s. If an SSD sentence is applied the DTE field should be evaluated together with the HBT sentence to define if the external equipment is able to display text messages.

Table 7 describes the messages or target information derived from received messages which should be displayed on the MKD:

Table 7 – Message display on MKD

Message type	Information content	Remark
All messages below	MMSI	
Message 1, 2, 3 Position report	Position (Lat, Lon, Range, Bearing) Time in minutes since last position report was received (0-19) For AIS-SART name shall show "SART ACTIVE" or "SART TEST" as appropriate PA-flag, RAIM, time stamp, description of position quality as derived from Table 8	In graphical display by position on the chart
Message 5 Static data	Name of ship	
Message 4 Base station report	Position (Lat, Lon, Range, Bearing) Time in minutes since last position report was received Name shall show "BS:MMSI" unless the name is derived from a Message 24a. PA-flag, RAIM, description of position quality as derived from Table 8	In graphical display by position on the chart
Message 9 SAR aircraft position report	Position (Lat, Lon, Range, Bearing, Altitude) Time in minutes since last position report was received Name shall show "SAR" PA-flag, RAIM, time stamp, description of position quality as derived from Table 8	In graphical display by position on the chart. The range to SAR air craft should be by 2-dimensional calculation.
Message 11	The result of the communication test should be displayed.	The indication of the result should be automatically removed not later than 30 s

Message type	Information content	Remark
Message 12, 14 Safety related text message	Text content For AIS-SART "SART ACTIVE" or "SART TEST" as appropriate	
Message 18, 19	Position (Lat, Lon, Range, Bearing) Time in minutes since last position report was received PA-flag, RAIM, time stamp, description of position quality as derived from Table 8	In graphical display by position on the chart Maybe filtered in or out (and filtering indicated)
Message 19, 24a Class B position and static report	Name of ship	
Message 21 Aid to navigation report	Name of Aids to Navigation Time in minutes since last position report was received Position (Lat, Lon, Range, Bearing) PA-flag, RAIM, time stamp, description of position quality as derived from Table 8 Off-position flag	Name plus indication it is an AtoN In graphical display by position on the chart

Table 8 – Position quality

Description	Criteria
No position	Position = 91°/ 181° Time stamp = 63
Manual position	Time stamp = 61
Dead reckoning position	Time stamp = 62
Outdated position > 200 m	Predicted distance (from SOG and time elapsed) > 200 m
Position > 10 m	PA = 0 and RAIM = 0
Position with RAIM > 10 m	PA = 0 and RAIM = 1
Position < 10 m	PA = 1 and RAIM = 0
Position with RAIM < 10 m	PA = 1 and RAIM = 1
Valid position with no time stamp	Time stamp = 60
NOTE Detailed information about the Quality of Position is displayed in a sub-page.	

6.11.2 Communication test

The AIS shall have a means of testing communication over the VDL by transmitting an addressed Message 10 and verifying the response of the addressed station, Message 11.

It shall be possible to initiate the communication test manually by MKD. The MKD shall propose a target and allow the user to confirm this target or select an alternate Class A target. A different target shall be suggested if the test fails.

It shall also be possible to initiate the communication test via the presentation interface input using an AIR sentence (indicating Message 11 in the "Message ID" field). In response to the AIR sentence the AIS unit shall transmit a Message 10.

Upon reception of a Message 10 the AIS unit shall respond with a Message 11.

The result of the communication test shall be displayed. The operation manual shall provide guidance on use of this feature such that the selected addressed target is at a suitable range for example between 15 NM and 25 NM.

6.11.3 Alarms and status information

6.11.3.1 Alarms

The following alarms shall be indicated and displayed on request:

- as a result of the built-in integrity test (BIIT see 6.10.1 and Annex F);
- reception of Message 1 NavStatus 14. Once acknowledged for a given User ID the relay will not be activated and the ALR will indicate acknowledge. The acknowledgement shall stay in effect until it is removed from the target list due to time out.

A means to acknowledge alarms shall be provided.

6.11.3.2 Status information

The following status information shall be indicated and the information contents displayed on request:

- indications as a result of the built-in integrity test (BIIT see 6.10.1);
- received safety related Messages 12 and 14;
- received long-range interrogations;
- manual confirmation of long-range interrogation if in manual mode.

An indication is required when status information is available or a Message 14 is received.

The content of the most recent Message 12 received shall be displayed foremost until cleared by the user. A minimum queue size of 20 Message 12 shall be accessible.

6.11.4 Data protection

The following data shall be protected from unauthorised modification (for example by password):

- MMSI;
- Call sign;
- Name of ship;
- IMO number;
- Dimension/Reference for position;
- Type of ship (type of cargo should not be protected);
- Interface configuration;
- Password(s);
- Message 27 tx channels.

Other data, if protected, should not be protected by the same password level.

NOTE If the EPV configuration sentence is used (see Annex E) a preceding valid SPW sentence will provide authorization.

6.11.5 Distance calculation

The AIS shall use the equations in Annex G to calculate all distances including range to other AIS stations and regional areas.

6.12 Protection from invalid controls

The AIS shall not accept the control commands sent from stations with invalid base station MMSI. Before accepting and processing the Messages 4, 16, 17, 20, 22 and 23, the AIS shall check the MMSI of the transmitting station. A valid base station MMSI is defined as "00xyyyyy" where x is between 2 and 7. The unit shall only accept and process received commands with a valid base station MMSI. See Annex D.

7 Technical requirements

7.1 General

(M.1371/A2-1.1) *This clause covers layers 1 to 4 (Physical Layer, Link Layer, Network Layer, Transport Layer) of the Open System Interconnection (OSI) model.*

Figure 1 illustrates the layer model of an AIS station (Physical Layer to Transport Layer) and the layers of the applications (Session Layer to Application Layer).

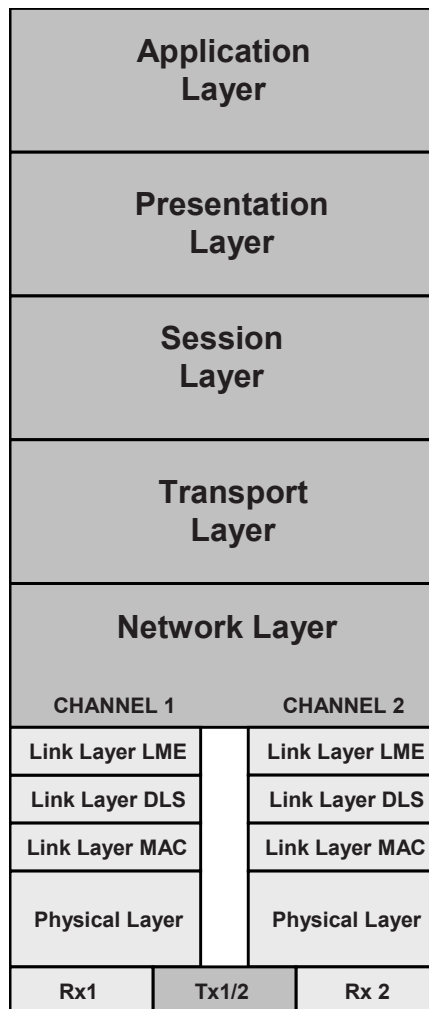

IEC 1929/12

Figure 1 – OSI layer model

7.2 Physical layer

(See Clause 15)

7.2.1 General

(M.1371/A2-2) *The Physical layer is responsible for the transfer of a bit-stream from an originator out, on to the data link.*

The Physical layer shall be designed in accordance with Recommendation ITU-R M.1371-4/A2-2.

7.2.2 Transmitter parameters

Transmitter parameters shall be as given in Table 9.

Table 9 – Transmitter parameters

Transmitter parameters	Requirement	Condition
Frequency error	± 500 Hz normal $\pm 1\,000$ Hz extreme	
Carrier power (P_{SS})	41 dBm high power setting 30 dBm low power setting	$\pm 1,5$ dB normal and ± 3 dB extreme, conducted
Modulation spectrum	-25 dBc -70 dBc slotted transmission	$\Delta f_c < \pm 10$ kHz ± 25 kHz $< \Delta f_c < \pm 62,5$ kHz
Modulation accuracy	1 740 \pm 175 Hz normal ± 350 Hz extreme 2 400 \pm 240 Hz normal ± 480 Hz extreme	Test signal 0101... Test signal 00001111...
Power versus time characteristics	Transmission delay: 0 s Ramp up time: 833 μ s Ramp down time: 833 μ s Transmission duration: $\leq 26\,624$ μ s	See Figure 2 and Table 10 Nominal 1 time slot transmission
Spurious emissions	-36 dBm -30 dBm	9 kHz ... 1 GHz 1 GHz ... 4 GHz

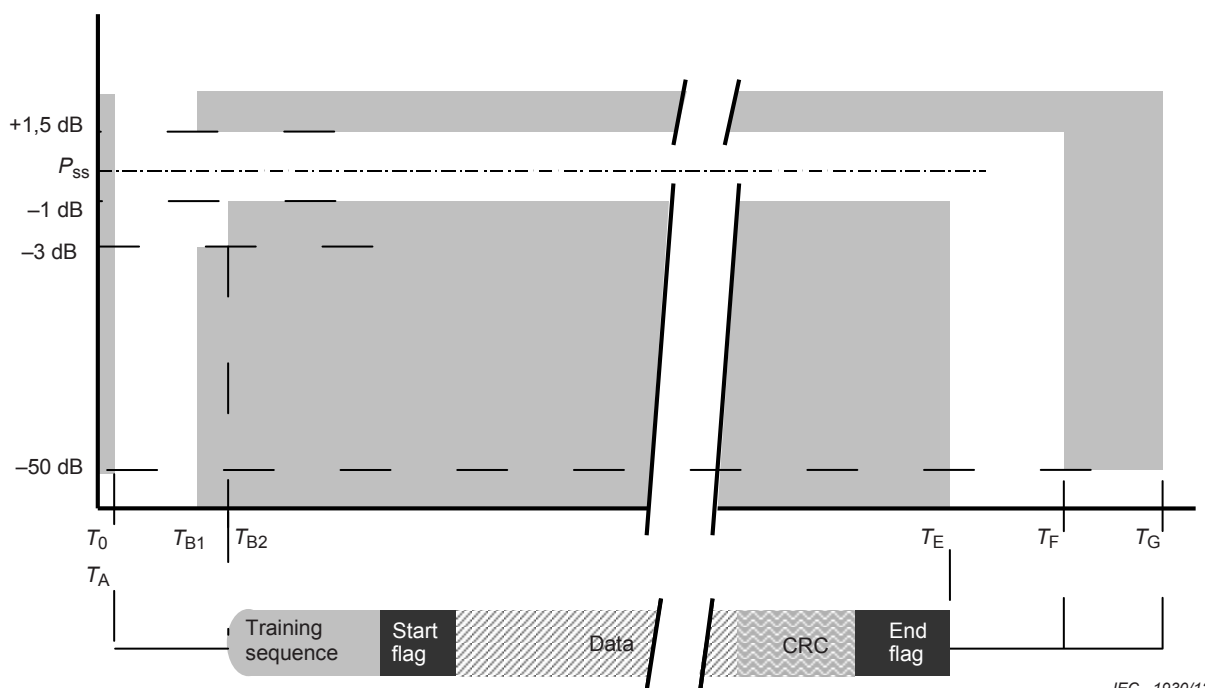

IEC 1930/12

Figure 2 – Power versus time characteristics

Table 10 – Power versus time characteristics

Reference	Bit	Time	Definition
T_0	0	0 ms	Start of transmission slot. Power shall NOT exceed -50 dBc (ref. P_{ss}) before T_0
T_A	0 to 6	0 to 0,625 ms	Power exceeds -50 dB of P_{ss}
T_B	T_{B1}	6	Power shall be within +1,5 or -3 dB of P_{ss}
	T_{B2}	8	Power shall be within +1,5 or -1 dB of P_{ss} :(Start of training sequence)
T_E (includes 1 stuffing bit)	233	24,271ms	Power shall remain within +1,5 or -1 dB of P_{ss} during the period T_{B2} to T_E
T_F (includes 1 stuffing bit)	241	25,104 ms	Power shall be -50 dBc (ref. P_{ss} a) and stay below this
T_G	256	26,667 ms	Start of next transmission time period

7.2.3 Receiver parameters

Receiver parameters shall be as given in Table 11.

Table 11 – Receiver parameters

Receiver parameters	Requirement		
	Result in PER	Wanted signal	Unwanted signal(s)
Sensitivity	20 %	-107 dBm normal -104 dBm normal at ± 500 Hz offset -101 dBm extreme	
Error at high input levels	1 %	-7 dBm and -77 dBm	-
Co-channel rejection	20 %	-104 dBm -104 dBm	-114 dBm nominal -114 dBm at ± 1 kHz offset
Adjacent channel selectivity	20 %	-104 dBm -98 dBm extreme	-34 dBm normal -38 dBm extreme
Spurious response rejection	20 %	-104 dBm	-34 dBm
Intermodulation response rejection and blocking	20 %	-101 dBm	-27 dBm (< 5 MHz) -15 dBm (> 5 MHz)
Spurious emissions	-57 dBm -47 dBm	9 kHz ... 1 GHz 1 GHz ... 4 GHz	

7.3 Link layer

(See Clause 16)

7.3.1 General

(M.1371/A2-3) *The Link layer specifies how data shall be packaged in order to apply error detection and correction to the data transfer. The Link layer is divided into three (3) sublayers.*

7.3.2 Link sublayer 1: Medium Access Control (MAC)

(M.1371/A2-3.1) *The MAC sublayer provides a method for granting access to the data transfer medium, i.e. the VHF data link. The method used shall be a Time Division Multiple Access (TDMA) scheme using a common time reference.*

The Medium Access Control sublayer shall be designed in accordance with Recommendation ITU-R M.1371-4/A2-3.1.

7.3.3 Link sublayer 2: Data Link Service (DLS)

(M.1371/A2-3.2) The DLS sublayer provides methods for:

- 1) *data link activation and release;*
- 2) *data transfer; or*
- 3) *error detection and control.*

The Data Link Service sublayer shall be designed in accordance with Recommendation ITU-R M.1371-4/A2-3.2.

Repeated messages and Class B messages shall not be used in the indirect synchronisation process.

7.3.4 Link sublayer 3 – Link Management Entity (LME)

7.3.4.1 General

(M.1371/A2-3.3) *The LME controls the operation of the DLS, MAC and the physical layer.*

The Link Management Entity sublayer shall be designed in accordance with Recommendation ITU-R M.1371-4/A2-3.3.

Link sublayer 3 includes definition of VDL-messages. Table 12 shows the VDL messages that shall be used by a Class A shipborne mobile AIS device.

Table 12 – Use of VDL messages

Msg. No.	Name of message	M.1371Ref.	R/P	O	T	Remark
0	Undefined	None	Yes	Yes	No	Reserved for future use
1	Position report (scheduled)	A8-3.1	Yes	Yes	Yes	If MMSI starts with 97 and NavStatus is 15 then it should only be sent to the PI in special AIS-SART test mode
2	Position report (assigned)	A8-3.1	Yes	Yes	Yes	
3	Position report (when interrogated)	A8-3.1	Yes	Yes	Yes	
4	Base station report	A8-3.2	Yes (5)	Yes	No	
5	Static and voyage related data	A8-3.3	Yes	Yes	Yes	
6	Addressed binary message	A8-3.4	Yes	Yes (1)	Yes	(1) Only if addressed to own station
7	Binary acknowledge	A8-3.5	Yes	INF (2)	Yes	(2) An ABK PI message shall be sent to the PI in any case
8	Binary broadcast message	A8-3.6	Yes	Yes	Yes	

Msg. No.	Name of message	M.1371Ref.	R/P	O	T	Remark
9	Standard SAR aircraft position report	A8-3.7	Yes	Yes	No	
10	UTC and date inquiry	A8-3.8	Yes	INF	Yes	
11	UTC/ date response	A8-3.9	Yes	INF	Yes	
12	Addressed safety related message	A8-3.10	Yes	Yes (3)	Yes	(3) Only if addressed to own station
13	Safety related acknowledge	A8-3.11	Yes	INF (4)	Yes	(4) An ABK PI message shall be sent to the PI in any case
14	Safety related broadcast message	A8-3.12	Yes	Yes	Yes	If MMSI starts with 97 and text is "SART TEST" then it should only be sent to the PI in special AIS-SART test mode
15	Interrogation	A8-3.13	Yes	INF	Yes	Class A shipborne mobile station shall only interrogate for Message 3, 4, 5, 9, 18, 19, 21 and 24 Slot offset shall be set to 0 and shall respond for interrogations for Messages 3, 5 and 24B only
16	Assigned mode command	A8-3.14	Yes (5)	INF	No	(5) Class-A AIS shall receive and process only if the message is sent from the station with valid base station MMSI
17	DGNSS	A8-3.15	Yes (5, 6)	INF (7)	No	(6) only if internal GNSS receiver is capable of processing DGNSS corrections or PI contains an DGNSS output port (7) on other ports of the PI: INF
18	Standard Class B equipment position report	A8-3.16	Yes	Yes	No	
19	Extended Class B equipment position report	A8-3.17	Yes	Yes	No	
20	Data link management message	A8-3.18	Yes (5)	INF	No	
21	Aids-to-Navigation report	A8-3.19	Yes	Yes	No	
22	Channel management message	A8-3.20	Yes (5)	INF	No	
23	Group assignment command	A8-3.21	Yes (5)	Yes	No	
24	Static data report (single slot, two parts)	A8-3.22	Yes	Yes	Yes	
25	Single slot binary message	A8-3.23	Yes	Yes (8)	Yes (9)	(8) Only if broadcast or addressed to own station (9) use ABM or BBM sentence indicating Message 25/70 in message ID field to initiate
26	Multiple slot binary message with CommState	A8-3.24	Yes	Yes (10)	Yes (11)	(10) Only if broadcast or addressed to own station (11) use ABM or BBM sentence indicating Message 26/71 in message ID field to initiate
27	Long-range AIS broadcast message	A8-3.25	No	No	Yes	Transmit on dedicated channels (not AIS 1 and AIS 2).
28 to 63	Undefined	None	INF	INF	No	Reserved for future use

Msg. No.	Name of message	M.1371Ref.	R/P	O	T	Remark
Key						
R/P – Receive and process internally, e.g. prepare for output via PI, act upon the received information, and use the received information internally.						
O – Output message content via PI using PI VDM messages						
T – Transmission by own station: "Yes" = required; "No" = shall not be transmitted						
INF – VDL message will be output via PI using a PI VDM message for information only. This function may be suppressed by configuration setting.						

For Messages 6, 8, 12, 14, 25 and 26 own transmissions shall not exceed the total number of slots in a frame with a maximum number of consecutive slots per message as defined in Recommendation ITU-R M.1371. For Message 15 own transmissions shall not exceed a total of 5 messages in a frame. If either case is exceeded, the AIS shall generate an ABK warning sentence.

7.3.4.2 Response to assignment commands (Messages 16 and 23)

Class A AIS shall process assignment commands in accordance with Recommendation ITU-R M.1371-4 only if the commands are sent from stations with valid base station MMSI.

An assignment command received by Message 16 or Message 23, with a reporting interval shorter than or equal to the autonomous reporting interval shall be processed and the reporting interval defined by the assignment command be used.

An assignment command received by Message 16 or Message 23 with a reporting interval longer than the autonomous reporting interval shall be ignored.

A group assignment by Message 23 shall not apply to Class A mobile stations with NavStatus "moored" and "at anchor" and not moving faster than 3 kn except when the station type is 10 (see 8.3).

7.4 Network layer

(See Clause 17)

7.4.1 General

(M.1371/A2-4) *The network layer shall be used for:*

- 1) *establishing and maintaining channel connections;*
- 2) *management of priority assignments of messages;*
- 3) *distribution of transmission packets between channels;*
- 4) *data link congestion resolution.*

The network layer shall be designed in accordance with Recommendation ITU-R M.1371-4/A2-4.

7.4.2 Management of regional operating settings

All stored regional operating settings shall be time/date-tagged and they should be tagged with information by what input means this regional operating setting was received (TDMA Message 22, DSC telecommand, Manual input via MKD, ACA sentence input via presentation interface). It shall be possible to obtain an ACA sentence giving the current stored area settings by means of a query sentence \$xxAIQ,ACA.

The AIS shall constantly check, if the nearest boundary of the regional operating area of any stored regional operating setting is more than 500 NM away from the current position of own station, or if any stored regional operating setting was older than 24 h. The age of the area setting is the time since the area setting has been applied the last time by Message 22, DSC command, MKD or ACA input. The “Time of in-use change” provided by ACA output cannot be used for this purpose. Any stored regional operating setting which fulfils any one of these conditions shall be erased from the memory.

The regional operating settings set shall be handled as a whole, i.e. a change requested for any parameter of the regional operating settings shall be interpreted as a new regional operating setting. However, in case that the narrow bandwidth (12,5 kHz) operation is requested, the AIS shall continue the wide bandwidth operation (25 kHz) while accepting other parameter changes.

When the user requests to manually input a regional operating setting via the MKD, the regional operating settings in use, which may be the default operating settings, shall be presented to the user on the MKD. The user shall then be allowed to edit these settings partly or in full. The AIS shall ensure that a regional operating area is always input and that it conforms to the rules for regional operating areas laid out in Recommendation ITU-R-M.1371-4/A2-4.1. After completion of input of an acceptable regional operating settings set, the AIS shall require the user to confirm a second time that the input data shall be stored and possibly used instantaneously.

The AIS shall not accept, i.e. shall ignore, any new regional operating setting which includes a regional operating area, which does not conform to the rules for regional operating areas laid out in Recommendation ITU-R M.1371-4/A2-4.1. The area size calculation shall be in accordance with Annex G.

The AIS shall not accept a new regional operation setting if the distance to the base station is more than 120 NM or if no message 4 is received from the base station.

The AIS shall not accept a new regional operating setting, which was input to it via the presentation interface, if the regional operating area of this new regional operating setting partly or totally overlaps or matches the regional operating area of any of the stored regional operating settings, which were received from a base station either by Message 22 or by DSC telecommand within the last two hours.

A Message 22 addressed to own station or a DSC telecommand not including the coordinates of the corner points shall be accepted only if the AIS is in a region defined by one of the stored regional operating settings. In this case the set of regional operating settings shall be composed by combining the received parameters with the regional operating area in use.

If the regional operating area of the new, accepted regional operating setting overlaps in part or in total or matches the regional operating areas of one or more older regional operating settings, this or these older regional operating settings shall be erased from the memory. The regional operating area of the new, accepted regional operating setting may be neighbouring tightly and may thus have the same boundaries as older regional operating settings. This shall not lead to the erasure of the older regional operating settings.

Subsequently the AIS shall store a new, accepted regional operating setting in one free memory location of the eight memories for regional operating settings. If there is no free memory location, the most distant regional operating setting shall be replaced by the new, accepted one.

NOTE The distance to a regional operating setting is the distance to the nearest boundary.

No means other than defined herein shall be allowed to clear any or all of the stored regional operating settings. In particular, it shall not be possible to solely clear any or all of the stored

regional operating settings by a manual input via the MKD or by an input via the presentation interface without inputting a new regional operating setting.

When the ship goes outside the regional area, the AIS shall revert all the parameters to default.

7.5 Transport layer

(See Clause 18)

(M.1371/A2-5) *The transport layer shall be responsible for:*

- 1) *converting data into transmission packets of correct size;*
- 2) *sequencing of data packets;*
- 3) *interfacing protocol to upper layers.*

The transport layer shall be designed in accordance with Recommendation ITU-R M.1371-4/ A2-5.

7.6 Presentation interface

(See Clause 19)

7.6.1 General

(M.1371/A2-5.4) *Data, which is to be transmitted by the AIS device, shall be input via the presentation interface. Data, which is received by the AIS device, shall be output through the presentation interface. The formats and protocol used for this data stream are defined in 7.6.*

(M.1371/A4-2) *Class A shipborne mobile equipment shall provide a two-way interface for equipment which provides for long-range communications. The interface shall comply with the following.*

The interface between the transport layer and higher layers shall be performed by the presentation interface. The Presentation Interface of the AIS shall comprise the data ports listed in Table 13. (Also see Annex B).

Table 13 – Presentation interface access

General function	Mechanism
Automatic input of sensor data (Sensor data input from shipboard equipment)	IEC 61162-2 input ports, also configurable as IEC 61162-1 input ports – minimum 3 ports required
High speed input/output ports (including pilot port) (Operator controlled commands and data input; AIS VHF Data Link (VDL) data; and AIS equipment status)	IEC 61162-2 paired input and output ports – minimum 2 ports required The long-range communications port may be configured as an additional presentation interface (PI) port if it is not needed for long-range communication in the current installation
Long-range communications	IEC 61162-2 paired input and output port
BITT alarm output	Isolated normally-closed (NC) contact circuit

7.6.2 Automatic input of sensor data

7.6.2.1 Required ports

A minimum of three input ports shall be provided. Each port shall meet the requirements of IEC 61162-2 and be capable of being reconfigured according to IEC 61162-1.

7.6.2.2 Interface connector

The manufacturer shall specify the connector and pin assignments for these ports.

7.6.2.3 Format of sensor data

The sensor data shall be provided using the formats described in IEC 61162-1. As a minimum, the required IEC 61162-1 sentences listed in Table 14 shall be received and processed by an AIS unit. Details for these sentences are contained in IEC 61162-1.

Table 14 – IEC 61162-1 sensor sentences

Data	IEC 61162-1 sentences
Reference datum	DTM
Positioning system: Time of position Latitude/Longitude Position accuracy	GNS, RMC
Speed over ground (SOG)	RMC, VBW, VTG
Course over ground (COG)	RMC, VBW, VTG
Heading	HDT, THS
RAIM indicator	GBS
Rate of turn (ROT)	ROT

The AIS shall use the DTM sentence to automatically confirm that the position information provided for transmission is in the WGS 84 datum.

The reception of periodic GBS sentences, containing values for the parameters "expected error in latitude" and "expected error in longitude" shall be used to indicate with the "RAIM-Flag" that the position sensor is operating with a RAIM process in use.

Each of the data items listed in Table 14 may be produced by various connected sensor equipment. The external sensor equipment is neither assigned to specific AIS input ports nor are the specified input sentences assigned to specific equipment. AIS shall be capable of accepting these specified sentences at each of the input ports.

A mechanism shall be implemented to avoid data mismatch or duplicate inputs if multiple sensor data for the same parameter is received by different sentences and/or ports. The mechanism shall be documented in a manufacturer's installation manual.

7.6.3 High speed input/output ports

7.6.3.1 Required ports

A minimum of two input/output ports shall be provided, a primary input/output port for connection of onboard control equipment, ECDIS, radar, etc., and a pilot/auxiliary input/output port for connection of ship's pilot equipment, service equipment, etc. Each port shall meet the requirements of IEC 61162-2.

Both input ports shall be functionally equivalent and shall be capable of receiving the data formats defined in Table 15.

Both output ports shall be functionally equivalent and shall be capable of simultaneously transmitting the data formats defined in Table 16.

7.6.3.2 Interface connector

If the pilot plug is provided it shall be configured as follows:

AMP/Receptacle (Square Flanged (-1) or Free-Hanging (-2)), Shell size 11, 9-pin,

Std. Sex 206486-1/2 or equivalent with the following terminations:

- Tx A is connected to Pin 1
- Tx B is connected to Pin 4
- Rx A is connected to Pin 5
- Rx B is connected to Pin 6
- Shield is connected to Pin 9

The manufacturer shall specify the connections for the remaining ports.

7.6.3.3 Input data and formats

The AIS shall as a minimum be able to receive and process the input data shown in Table 15. The details of these sentences are contained in IEC 61162-1. Manufacturer's proprietary data may also be entered using these high-speed ports.

Table 15 – AIS High-speed input data and formats

Data	IEC 61162-1 sentences
Normal access – Parameter entry	
Voyage information: Vessel type and cargo category Navigational status Draught, max. actual static Destination ETA date and time Regional application flags	VSD
Station information Vessel name Call sign Antenna location Length and beam	SSD
Initiate VHF data-link broadcasts	
Safety messages	ABM ^b
Handshake to acknowledge received safety message by a remote MKD	BBM ^b ABK ^b
Binary messages	ABM ^b BBM ^b
Interrogation message	AIR

Data	IEC 61162-1 sentences
Normal access – Parameter entry	
AIS equipment – Parameter entry	
AIS VHF channel selection AIS VHF power setting AIS VHF channel bandwidth Transmit/Receive mode control	ACA ^a
BIIT input	
Heartbeat from remote MKD	HBT
Alarm / indication acknowledgement	ACK
LR acknowledge	
Manual LR acknowledge	LRF
^a The AIS requires that information in the longitude and latitude fields of the ACA sentence is truncated to 1/10 min. ^b ABK, ABM and BBM are defined in Annex H.	

7.6.3.4 Output data and formats

The AIS shall as a minimum be able to generate and send the output data shown in Table 16.

The VDO sentence (containing Messages 1, 2 or 3) shall be output on both high-speed output ports, at nominal 1 s intervals, use A and B to indicate that the data was transmitted on the VDL channel A or B, null indicating not transmitted on the VDL.

The VDM sentence shall be sent simultaneously on both high-speed output ports for every VDL message received. Some VDL messages are informative according to Table 12. During operation, the operator may disable delivery of these informative messages. Manufacturer's proprietary data may also be sent using these high-speed ports.

Table 16 – AIS high-speed output data and formats

Data	IEC 61162-1 sentences
Prepared by AIS unit	
Notification that a session initiated by messages ABM, BBM, AIR is terminated	ABK
AIS own-ship broadcast data (all transmissions available)	VDO
AIS equipment status (Built-in-integrity-test results)	ALR/TXT – (see 6.10.2)
Channel management data (using query mechanism)	ACA
Received on VHF data-link by AIS unit	
All VDL AIS messages received Broadcast or Addressed to own station	VDM
Received on LR communication system	
LR interrogation message received	LRI and LRF
System Information in response to a query	
Static information	SSD
Voyage information	VSD
Version information	VER
Status information	TXT
NOTE If the internal GNSS of the AIS is intended to be used for the ship's position source, then sentences DTM, GNS, GBS and RMC are required to be generated and sent as output data (see 6.2.1).	

7.6.3.5 Additional optional sentences

Additional optional sentences to facilitate communication with external devices providing the functionality of an MKD (6.11) are given in Annex E.

7.6.4 Long-range communication ports

7.6.4.1 Required ports

A minimum of one input/output port shall be provided and shall meet the requirements of IEC 61162-2. It may be connected to long-range communications equipment (for example satellite communications; see Clause 8).

The input port shall be capable of receiving the data formats defined in Table 17.

The output port shall be capable of transmitting the data formats defined in Table 18.

7.6.4.2 Interface connector

The manufacturer shall specify the connector and pin assignments for these ports.

7.6.4.3 Input data and formats

Long-range interrogation of an AIS unit is accomplished through the use of two IEC 61162-1 sentences – LRI and LRF. This pair of interrogation sentences provides the information needed by the AIS unit to determine if it should construct and provide the reply sentences – LR1, LR2, and LR3. The LRI sentence contains the information needed to determine if the reply needs to be constructed. The LRF sentence identifies the information that is being requested.

The information that can be requested by the LRF sentence is shown in Table 17. Details of these sentences are contained in IEC 61162-1.

Table 17 – AIS Long-range communications input data and formats

Data	IEC 61162-1 sentences
Long-range interrogation Type of request Geographic area request AIS unit request	LRI
Long-range function identification Requestor MMSI and name Request for: Ship's name, call sign, and IMO number (A) Date and time of message composition (B) Position (C) Course over ground (E) Speed over ground (F) Destination and ETA (I) Draught (O) Ship / Cargo (P) Ship's length, breadth, and type (U) number of persons on board (W)	LRF

7.6.4.4 Output data and formats

The long-range reply from the AIS unit is accomplished through the use of four IEC 61162-1 sentence formatters – LRF, LR1, LR2 and LR3. The AIS unit shall reply with these sentences, in the following order; LRF, LR1, LR2 and LR3 when responding to an interrogation even if all the information items in the sentence are null.

The LRF-sentence provides the “function reply status” for the requested information. The following is a list of “function reply status” characters with the status that represent:

- 2 = information available and provided in the following LR1, LR2 and LR3 sentence;
- 3 = information not available from AIS unit;
- 4 = information is available but not provided (i.e. restricted access determined by ship’s master)”.

The LR1 sentence identifies the destination for the reply and contains the information items requested by the "A" function identification character in the LRF sentence.

The LR2 sentence contains the information items requested by the "B, C, E, and F" function identification characters in the LRF sentence.

The LR3 sentence contains the information items requested by the "I, O, P, U and W" function identification characters in the LRF sentence.

The individual information items shall be “null” if any of the following conditions exist:

- the information item was not requested in the LRF sentence;
- the information item was requested but is not available; or
- the information item was requested but is not being provided.

The output data shown in Table 18 shall be provided when specifically requested by function identification characters contained in the preceding LRF-sentence portion of the interrogation. Details of these sentences are contained in IEC 61162-1.

Table 18 – LR output data formats

Data	IEC 61162-1 sentences
Function reply status	LRF
MMSI of responder MMSI of requestor Ship's name Ship's call sign IMO number	LR1
MMSI of responder Date and time of message composition Position Course over ground Speed over ground	LR2
MMSI of responder Destination and ETA Draught Ship/Cargo Ship's length, breadth, and type Number of persons on board	LR3

7.6.5 BIIT alarm output

The AIS shall provide a relay output (NC contact) indicating the state of the Built-In Integrity Test (BIIT) alarm function as specified in 6.10.1.

The terminals shall be isolated from circuits and grounds in the AIS.

The AIS manufacturer's documentation shall specify the current and voltage capability of the alarm relay contacts.

8 Long-range applications

8.1 General

Long-range applications shall be by interface to other equipment (8.2) and by broadcast (8.3).

8.2 Long-range application by two-way interface

(See 20.1)

8.2.1 General

Long-range (LR) communications shall be only through the presentation interface using the IEC 61162-2 interface dedicated to this purpose as described in 7.6.4.

The LR AIS data shall be displayed on the AIS display as described in 6.11.

8.2.2 Interrogations and responses

LR information shall only be transmitted in response to an interrogation from a LR base station

8.2.3 Manual and automatic response

The AIS transponder shall be capable of being set by the user to respond automatically or manually to LR interrogations. In case of automatic reply to LR interrogations, the display shall indicate that the system was LR interrogated until the indication is acknowledged by the operator. In case of manual reply to LR interrogation, the display shall indicate that the system was LR interrogated until the operator has replied to the interrogation or cancelled the reply on the manual input device as described in 6.11.

8.2.4 Data formats and contents

The LR data types available for transmission shall be derived from the AIS system as described in Table 19.

Table 19 – LR data types

ID	Data types Format	Remarks
A	Ship name/call sign MMSI/IMO number	MMSI number shall be used as a flag identifier
B	Date and time in UTC	Time stamp of message composition shall be given in UTC only. Day of month, hours and minutes
C	Position	WGS 84; Latitude / Longitude degrees and minutes
D		Not available
E	Course	Course over ground (COG) in degrees
F	Speed	Speed over ground (SOG) in knots and 1/10 knots
G, H		Not available
I	Destination/ETA	At master's discretion; ETA time format, see B
J, K, L, M, N		Not available
O	Draught	Actual maximum draught in 1/10 of metres
P	Ship/Cargo	See Recommendation ITU-R M.1371-4/A8-3.3, Table 49
Q, R, S, T		Not available
U	Length/Beam/Type	Length and beam in metres Type see Recommendation ITU-R M.1371-4/A8-3.3, Table 49, tonnage not available
V		Not available
W	Number of persons on board	
X,Y		Not available
Z		Not used

8.2.5 Addressing AIS-units

LR interrogations shall be either by user ID (ship's MMSI) or by geographical area "all ships" call designating the North-Eastern corner and the South-Western corner of the Mercator projection rectangle, which describes the called area.

The first LR data transfer shall take place by LR interrogation initiated by a geographical area "All ships" call.

Succeeding LR data transfers shall take place by LR interrogation based on user ID (MMSI).

To avoid replies on succeeding geographical area "All ships" calls from the same base station, the AIS shall store the MMSI of the LR base station for 24 h.

8.3 Long-range application by broadcast

(See 14.1.1, 20.2)

Long-range application by broadcast is described in Recommendation ITU-R M.1371-4/A4.

Long-range AIS receiving systems (for example a satellite based receiver) will receive long-range AIS broadcast messages, provided these messages are appropriately structured and transmitted to suit the receiving systems.

The long-range AIS broadcast Message 27 shall be transmitted only on the two separate designated channels and not on the AIS channels (AIS 1, AIS 2 or regional channels). The transmissions should alternate between these two channels such that each channel is used once every 6 min. The broadcast of Message 27 in coastal areas is subject to base station control through the combined use of Message 4 and Message 23 with station type 10.

NOTE 1 Station type 10 has not yet been defined by the ITU-R in Recommendation ITU-R M.1371-4 but is expected to be defined as the base station coverage area for control of Message 27 transmissions by Class A mobile stations.

The AIS shall have the capability of disabling this function during normal operation.

NOTE 2 The assignment of the two separate designated channels was approved by ITU World Radiocommunication Conference 2012 (WRC-12) by amending the Radio Regulations. This standard uses Channel 75 (156,775 MHz) and Channel 76 (156,825 MHz) as the separate designated channels. The amendments enter into force from 1 January 2013.

9 Test conditions

9.1 Normal and extreme test conditions

9.1.1 Normal test conditions

9.1.1.1 Temperature and humidity

Temperature and humidity shall be within following range:

Temperature	+15 °C to +35 °C
Humidity	20 % to 75 %

9.1.1.2 Power supply

The normal power supply for the tests shall be in accordance with IEC 60945.

9.1.2 Extreme test conditions

Extreme test conditions are as specified in IEC 60945. Where required, test under extreme test conditions shall be a combination of dry heat and upper limit of supply voltage applied simultaneously and low temperature and lower limit of supply voltage applied simultaneously.

During type testing the power source to the equipment may be replaced by a test power source, capable of producing normal and extreme test voltages.

9.2 Standard test environment

The EUT is tested in an environment (see Annex C) using test equipment to simulate and to log VDL messages (see Table 12). Standard environment includes simulated targets. The simulated targets shall include an appropriate number of targets of

- Class A Mobile,
- Class B “CS” Mobile,
- Class B “SO” Mobile,
- Base station,
- AIS AtoN Station,
- SAR Aircraft,
- AIS-SART.

A receiver for long-range AIS broadcast message (Message 27) reception shall also be provided.

The signal input level at the RF input port of the EUT for any simulated target shall be at least –100 dBm. Own ship sensor inputs to EUT will be simulated by the test system or other means. Operation is checked on channels in the maritime mobile band.

Channels in use shall be selected by manual input or channel assignment messages before starting tests.

9.3 Additional test arrangements

9.3.1 Arrangements for test signals applied to the receiver input

Sources of test signals for application to the receiver input shall be connected in such a way that the source impedance presented to the receiver input is 50 Ω (see 9.3.4).

This requirement shall be met irrespective of whether one or more signals using a combining network are applied to the receiver simultaneously.

The power levels of the test signals at the receiver input terminals (RF socket) shall be expressed in terms of dBm.

The effects of any intermodulation products and noise produced in the test signal sources shall be negligible.

9.3.2 Encoder for receiver measurements

Whenever needed and in order to facilitate measurements on the receiver, an encoder for the data system shall accompany the EUT, together with details of the normal modulation process. The encoder is used to modulate a signal generator for use as a test signal source.

Complete details of all codes and code format(s) used shall be given.

9.3.3 Waiver for receivers

If the manufacturer declares that both TDMA receivers are identical, the test may be limited to one receiver and the test for the second receiver may be waived. The test report shall mention this.

9.3.4 Impedance

In this standard the term "50 Ω" is used for a 50 Ω non-reactive impedance.

9.3.5 Artificial antenna (dummy load)

Tests shall be carried out using an artificial antenna which shall be a non-reactive non-radiating load of 50 Ω connected to the antenna connector.

9.3.6 Facilities for access

All tests shall be performed using the standard ports of the EUT. Where access facilities are required to enable any specific test, these shall be provided by the manufacturer.

9.3.7 Modes of operation of the transmitter

For the purpose of the measurements according to this standard, there shall be a facility to operate the transmitter unmodulated.

Alternatively, the method of obtaining an unmodulated carrier or special types of modulation patterns may also be decided by agreement between the manufacturer and the test laboratory. It shall be described in the test report. It may involve suitable temporary internal modifications of the equipment under test.

9.4 Common test conditions for protection from invalid controls

In all functional tests using Messages 4, 16, 17, 20, 22, 23 and DSC channel management telecommands, the messages or telecommands sender station shall use a valid base station MMSI format (see 6.12) to verify that the EUT operates as described in the required results. The tests shall be repeated using an invalid base station MMSI format for the messages or DSC telecommands sender station to verify that the EUT ignores these messages or telecommands.

9.5 Measurement uncertainties

Maximum values of absolute measurement uncertainties shall be as follows:

RF frequency	$\pm 1 \times 10^{-7}$
RF power	$\pm 0,75$ dB
Adjacent channel power	± 5 dB
Conducted spurious emission of transmitter	± 4 dB
Conducted spurious emission of receiver	± 3 dB
Two-signal measurement	± 4 dB
Three-signal measurement	± 3 dB
Radiated emission of transmitter	± 6 dB
Radiated emission of receiver	± 6 dB
Transmitter attack time	± 20 %
Transmitter release time	± 20 %

For the test methods according to this standard, these uncertainty figures are valid to a confidence level of 95 %.

The interpretation of the results recorded in a test report for the measurements described in this standard shall be as follows:

- a) the measured value related to the corresponding limit shall be used to decide whether an equipment meets the requirements of this standard;
- b) the actual measurement uncertainty of the test laboratory carrying out the measurements, for each particular measurement, shall be included in the test report;
- c) the values of the actual measurement uncertainty shall be, for each measurement, equal to or lower than the figures given in this clause (absolute measurement uncertainties).

10 Test signals

NOTE Transmitters may have limitations concerning their maximum continuous transmit time and/or their transmission duty cycle. It is intended that such limitations be respected during testing.

10.1 Standard test signal number 1 (DSC)

A DSC modulated data signal comprising an infinite series of 010101 (dotting pattern; refer to Recommendation ITU-R M.825).

10.2 Standard test signal number 2 (TDMA)

A test signal consisting of an infinite series of 010101.

10.3 Standard test signal number 3 (TDMA)

A test signal consisting of an infinite series of 00001111.

10.4 Standard test signal number 4 (PRBS)

A Pseudo Random Bit Sequence (PRBS) as specified in Recommendation ITU-T O.153 as the data within an AIS message frame with header, start flag, end flag and CRC. NRZI is not applied to the PRBS stream or CRC. The RF should be ramped up and down on either end of the AIS message frame.

10.5 Standard test signal number 5 (PRBS)

This test signal consists of 200 packets grouped into clusters of 4 as described in Figure 3. Each cluster consists of 2 consecutive transmissions of the packets described in Table 20.

NRZI shall be applied to every packet. After sending packet 1 and 2 the initial state of the NRZI process shall be inverted and then packet 1 and 2 repeated.

Between every transmitted packet there shall be at least 2 free time periods. The RF carrier shall be switched off between packets to simulate normal operation.

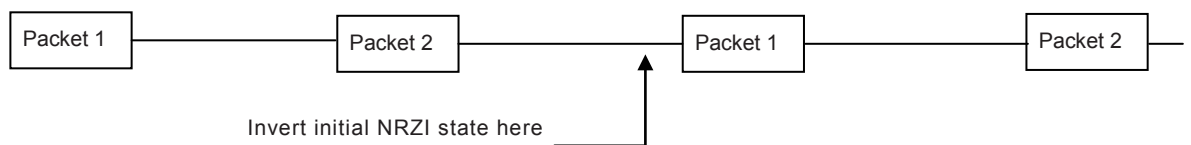

IEC 1931/12

Figure 3 – Format for repeating four-packet cluster

Table 20 – Content of first two packets

Packet	Parameter	Bits	Contents	Comment
1	Training	22	0101....0101	Preamble reduced by 2 bits because of ramp-up overlap
	Start flag	8	01111110	
	Data	168	Pseudo Random	As per Table 21
	CRC	16	Calculated	
	End flag	8	01111110	
2	Training	22	1010....1010	Preamble reduced by 2 bits because of ramp-up overlap
	Start flag	8	01111110	
	Data	168	Pseudo Random	As per Table 21
	CRC	16	Calculated	
	End flag	8	01111110	

Table 21 – Fixed PRS data derived from Recommendation ITU-T O.153

Address	Contents (HEX)							
0-7	0x04	0xF6	0xD5	0x8E	0xFB	0x01	0x4C	0xC7
	0000.0100	1111.0110	1101.0101	1000.1110	1111.1011	0000.0001	0100.1100	1100.0111
8-15	0x76	0x1E	0xBC	0x5B	0xE5	0x92	0xA6	0x2F
	0111.0110	0001.1110	1011.1100	0101.1011	1110.0101	1001.0010	1010.0110	0010.1111
16-20	0x53	0xF9	0xD6	0xE7	0xE0	21 Bytes = 168 bits (+ 4 stuffed bits), CRC = 0x3B85		
	0101.0011	1111.1001	1101.0110	1110.0111	1110.0000			

11 Power supply, special purpose and safety tests

Tests for power supplies, special purposes and safety shall be performed as specified in IEC 60945:2002, Clauses 7, 11 and 12. Waivers as indicated in IEC 60945 shall apply.

12 Environmental tests

For the environmental tests of IEC 60945:2002, Clause 8 the following shall apply:

Dry heat (IEC 60945) perform PC under lower extreme test voltage

Low temp (IEC 60945) perform PC under upper extreme test voltage

Normal temp (IEC 60945) no test (PT) required

Performance tests (PT) as required by 60945 under extreme conditions are covered by the tests in Clause 15 and for normal temperature under Clause 14.

For the performance checks (PC) to be used with the environmental tests, repeat test 14.1.1. (1 test target at least).

For equipment declared as “exposed” or “portable” the additional tests for these types apply.

13 EMC tests

Tests for EMC emissions shall be performed as specified in IEC 60945:2002, Clause 9.

Tests for EMC immunity shall be performed as specified in IEC 60945:2002, Clause 10.

To demonstrate compliance with the performance criteria for the EMC immunity tests, the EUT shall be set into autonomous mode using channels AIS 1 and AIS 2 with a reporting interval of 2 s in the standard test environment (9.2). The content of the reports and the reporting intervals shall not be degraded during or after the test, as appropriate for the considered criterion.

Performance criterion C of IEC 60945 shall be taken to mean that the functions of the EUT are self-recoverable, i.e. without operation of controls.

14 Operational tests

14.1 Identification and operating modes

(See 6.4)

14.1.1 Autonomous mode

14.1.1.1 Transmit position reports

14.1.1.1.1 Method of measurement

Set up standard test environment. Record the VDL communication and check for messages of the EUT as follows:

- a) Operate the EUT with the default MMSI (000000000).
- b) Attempt to program an invalid MMSI (outside of the range specified in 6.4).
- c) Enable the Message 27 transmission and repeat test with a programmed valid MMSI (see 8.3).
- d) Repeat test with a programmed MMSI and after a power down for 12 h.

14.1.1.1.2 Required results

Confirm that

- a) the EUT does not transmit with the default MMSI and an alarm 001 is activated,
- b) the EUT rejects an invalid MMSI programming and does not transmit with the default MMSI and an alarm 001 is activated,
- c) the EUT transmits autonomously when programmed with a valid MMSI and that the transmitted data complies with sensor inputs. Confirm that EUT transmits Message 27 as described in 8.3,
- d) all static and voyage related data has been retained for at least 12 h.

14.1.1.2 Receive position reports

14.1.1.2.1 Method of measurement

Set up standard test environment as follows:

- a) switch on test targets, then start operation of the EUT;
- b) start operation of the EUT, then switch on test targets.

Check the VDL communication and presentation interface outputs of the EUT.

14.1.1.2.2 Required results

Confirm that EUT receives continuously under conditions a) and b) and outputs the received messages via the PI.

14.1.2 Assigned mode

14.1.2.1 Method of measurement

Set up standard test environment and operate EUT in autonomous mode. Using a base station MMSI, transmit an assigned mode command Message 16 to the EUT with

- a) slot offset and increment,
- b) designated reporting interval.

Record transmitted messages.

14.1.2.2 Required results

Confirm that the EUT transmits position reports Message 2 according to defined parameters and reverts to SOTDMA Message 1 with standard reporting interval after 4 min to 8 min.

14.1.3 Polled mode

14.1.3.1 Transmit an interrogation

14.1.3.1.1 Method of measurement

Set up standard test environment and operate EUT in autonomous mode. Initiate the transmission of an interrogation message (Message 15) by the EUT addressing 1 or 2 destinations requesting the following responses:

- Message 3, 5, 9, 18, 19, 24 from mobile stations;
- Message 4, 24 from base stations.

Record transmitted messages.

14.1.3.1.2 Required results

Check that EUT transmits the interrogation message (Message 15) as appropriate.

14.1.3.2 Interrogation response

14.1.3.2.1 Method of measurement

Set up standard test environment and operate EUT in autonomous mode. Apply an interrogation message (Message 15; EUT as destination) to the VDL for responses with Message 3, Message 5 and slot offset set to a defined value which is greater than 10 slots. Record transmitted messages and frame structure.

14.1.3.2.2 Required results

Check that the EUT transmits the appropriate interrogation response message as requested after defined slot offset. Confirm that the EUT transmits the response on the same channel as where interrogation was received.

14.1.4 Addressed operation

14.1.4.1 Transmit an addressed message

14.1.4.1.1 Method of measurement

Set up standard test environment and operate EUT in autonomous mode.

- a) Initiate the transmission of an addressed binary Message 6; EUT as source by the EUT. Record the transmitted messages.
- b) Repeat test with the addressed safety related Message 12.
- c) Repeat test with the addressed unstructured binary Message 25.
- d) Repeat test with the addressed structured binary Message 25.
- e) Repeat test with a single addressed unstructured binary Message 26.
- f) Repeat test with a single addressed structured binary Message 26.

14.1.4.1.2 Required results

Check that

- a) the EUT transmits the Message 6 as appropriate,
- b) the EUT transmits the Message 12 as appropriate,
- c) the EUT transmits the Message 25 as appropriate.
- d) the EUT transmits the Message 25 as appropriate.
- e) the EUT transmits the Message 26 as appropriate.
- f) the EUT transmits the Message 26 as appropriate.

14.1.4.2 Receive addressed message

14.1.4.2.1 Method of measurement

Set up standard test environment and operate EUT in autonomous mode, as follows:

- a) Apply an addressed message (Message 6, 12, 25, 26; EUT as destination) to the VDL.
- b) Apply an addressed message (Message 6, 12, 25, 26; other station as destination) to the VDL.

Record transmitted messages and frame structure.

14.1.4.2.2 Required results

Check that EUT transmits the appropriate acknowledgement message. Confirm that

- a) EUT outputs the received message via the presentation interface,
- b) EUT does not output the received message via the presentation interface.

14.1.5 Broadcast operation

14.1.5.1 Transmit a broadcast message

14.1.5.1.1 Method of measurement

Set up standard test environment and operate EUT in autonomous mode as follows:

- a) Initiate the transmission of a broadcast binary Message 8; EUT as source by the EUT. Record the transmitted messages.
- b) Repeat test with the broadcast safety related Message 14.
- c) Repeat test with the broadcast unstructured binary Message 25.

- d) Repeat test with the broadcast structured binary Message 25.
- e) Repeat test with a single broadcast unstructured binary Message 26.
- f) Repeat test with a single broadcast structured binary Message 26.

14.1.5.1.2 Required results

Check that

- a) the EUT transmits the Message 8 as appropriate,
- b) the EUT transmits the Message 14 as appropriate,
- c) the EUT transmits the Message 25 as appropriate.
- d) the EUT transmits the Message 25 as appropriate.
- e) the EUT transmits the Message 26 as appropriate.
- f) the EUT transmits the Message 26 as appropriate.

14.1.5.2 Receive broadcast message

14.1.5.2.1 Method of measurement

Set up standard test environment and operate EUT in autonomous mode.

Apply a broadcast message (Message 8, 14, 25, 26) to the VDL.

14.1.5.2.2 Required results

Confirm that the EUT outputs the received message via the presentation interface.

14.1.6 Multiple slot messages

14.1.6.1 5 slot messages

14.1.6.1.1 Method of measurement

Apply a BBM sentence to the PI of EUT with a maximum of 121 data bytes of binary data in order to initiate transmission of a binary message (Message 8).

14.1.6.1.2 Required results

Check that the message is transmitted in up to 5 slots accordingly.

14.1.6.2 Longer messages

14.1.6.2.1 Method of measurement

Apply a BBM sentence to the PI of the EUT with an information content not fitting in 5 slots (i.e. more than 121 data bytes of binary data containing only binary bits with value one).

14.1.6.2.2 Required results

Check that the message is not transmitted. Check that a negative acknowledgement is given on the presentation interface.

14.2 Information

(See 6.5)

14.2.1 Information provided by the AIS

14.2.1.1 Method of measurement

Set up standard test environment and operate EUT in autonomous mode.

Apply all static, dynamic and voyage related data to the EUT.

Record all messages on VDL and check the content of position report Message 1 and static data report Message 5.

14.2.1.2 Required results

Confirm that data transmitted by the EUT complies with manual and sensor inputs.

14.2.2 Reporting intervals

14.2.2.1 Speed and course change

14.2.2.1.1 Method of measurement

Set up standard test environment and operate EUT in autonomous mode as follows:

- a) Start with own speed of 10 kn; record all messages on VDL for 10 min and evaluate reporting interval for position report of EUT by calculating average slot offset over test period.
- b) Increase speed and change course ($ROT > 10^\circ/\text{min}$, derived from heading).
- c) Reduce speed and rotation rate to values below those given in Table 1.
- d) Make speed sensor unavailable.
- e) Apply continuously changing heading data. Make heading sensor unavailable.

For b), c), d) record all messages on VDL and check slot offset between two consecutive transmissions.

14.2.2.1.2 Required results

The following results are required.

- a) Reporting interval shall comply with Table 1 (10 s with a tolerance of $\pm 10\%$).
- b) Confirm that the new reporting interval has been established.
- c) Confirm that the reporting interval is increased after 4 min (speed reduction) or 20 s (ROT reduction).
- d) Check that with unavailable speed sensor the reporting interval reverts to default.
- e) Check that with unavailable heading sensor the reporting interval reverts to autonomous reporting interval for the given speed.

14.2.2.2 Change of navigational status

14.2.2.2.1 Method of measurement

Set up standard test environment and operate EUT in autonomous mode. Change navigational status by applying voyage data message to the presentation interface of the EUT as follows:

- a) set NavStatus to "at anchor" and "moored" and speed < 3 kn;
- b) set NavStatus to "at anchor" and speed > 3 kn;
- c) set NavStatus to other values.

Record all messages on VDL and evaluate reporting interval of position report of EUT.

14.2.2.2.2 Required results

The following results are required:

- a) Reporting interval shall be 3 min.
- b) Reporting interval shall be 10 s.
- c) Reporting interval shall be adjusted according to speed and course (see Table 1).

NOTE Alarm conditions associated with NavStatus are tested in 14.6.3.6.

14.2.2.3 Assigned reporting intervals

14.2.2.3.1 Method of measurement

Set up standard test environment and operate EUT in autonomous mode. Using a base station MMSI, transmit an assigned mode command Message 16 to the EUT with

- a) initial slot offset and increment,
- b) designated reporting interval.

Change course, speed and NavStatus. Record transmitted messages.

14.2.2.3.2 Required results

Confirm that the EUT transmits position reports Message 2 according to the parameters defined by Message 16 if the reporting interval of the assignment is shorter than the autonomous reporting interval. The EUT shall revert to Message 1 or 3 in autonomous mode with the autonomous reporting interval

- after a period of 4 min to 8 min, or
- if a change of course, speed and NavStatus require a shorter autonomous reporting interval.

14.2.2.4 Static data reporting intervals

14.2.2.4.1 Method of measurement

Set up standard test environment and operate EUT in autonomous mode.

Record the transmitted messages and check for static and voyage related data (Message 5).

- a) Change static and/or voyage related station data. Record the transmitted messages and check for static and voyage related data (Message 5).
- b) Apply SSD and VSD sentences with the same static parameters several times.

14.2.2.4.2 Required results

Confirm that the EUT transmits Message 5 with a reporting interval of 6 min alternating Channel A and Channel B.

- a) Confirm that the EUT transmits Message 5 within 1 min reverting to a reporting interval of 6 min.
- b) Confirm that the EUT transmits Message 5 within 1 min after the first SSD sentence was received and revert to a reporting interval of 6 min. Subsequent identical SSD and VSD sentences shall not generate a further Message 5.

14.3 Event log

(See 6.6)

14.3.1 Method of measurement

Set up standard test environment and operate EUT in autonomous mode.

Switch the EUT off for more than 15 min and on again at least ten times. Recover and readout recorded data.

Switch the EUT to receive only mode if implemented. Recover and readout recorded data.

14.3.2 Required results

Confirm that the EUT records and displays times and events correctly.

14.4 Initialization period

(See 6.7)

14.4.1 Method of measurement

Set up standard test environment with all sensors available.

Switch on EUT with EUT operating in autonomous mode.

Switch off EUT for approximately 0,5 s. Record transmitted messages.

14.4.2 Required results

Confirm that the EUT starts transmissions within 2 min after switch on.

14.5 Technical characteristics

(See 6.9)

14.5.1 Channel selection

14.5.1.1 Method of measurement

Set up standard test environment and operate EUT in autonomous mode. Switch the EUT to different channels randomly selected from the maritime mobile band as specified by ITU-R M.1084-5, Annex 4 using 25 kHz channel spacing:

- a) manually;
- b) by transmission of channel management message (Message 22) broadcast and addressed to EUT using a base station MMSI;
- c) by application of ACA sentence to the presentation interface;
- d) by transmission of DSC telecommand to EUT using a base station MMSI.

Record the VDL messages.

14.5.1.2 Required results

Confirm that the EUT uses the appropriate channels as commanded in the tests.

Confirm that the EUT delivers a single TXT sentence with ID 036, followed by the ACA sentences needed to inform of changes in the AIS use of regional operating settings.

14.5.2 Transceiver protection

14.5.2.1 Method of measurement

Set up standard test environment and operate EUT in autonomous mode. Open circuit and short circuit VHF-antenna terminals of the EUT for at least 60 s each.

14.5.2.2 Required results

The EUT shall be operative again within 2 min after refitting the antenna without damage to the transceiver.

14.5.3 Automatic power setting

14.5.3.1 Method of measurement

Set up the standard test environment and operate EUT in autonomous mode as follows:

- a) Set NavStatus to moored, SOG to < 3 kn and ship type to “tanker”.
- b) Repeat test a) and assign the power level to high via the VDL.
- c) Change the NavStatus to underway

14.5.3.2 Required results

Verify that

- a) the power setting is 1 W and the MKD indicates the correct power setting,
- b) the power setting is 1 W and the MKD indicates the correct power setting,
- c) the power setting is 12,5 W and the MKD indication reverts to normal.

NOTE Other mechanisms for power setting are tested in 17.5.

14.6 Alarms and indicators, fall-back arrangements

(See 6.10)

14.6.1 Loss of power supply

14.6.1.1 Method of measurement

Disconnect power supplies of the EUT.

14.6.1.2 Required results

Verify that the relay output is “active” when the power is “off”.

14.6.2 Monitoring of functions and integrity

14.6.2.1 Tx malfunction

14.6.2.1.1 Method of measurement

Check the manufacturer’s documentation details how the EUT detects Tx malfunction.

14.6.2.1.2 Required results

Confirm that the requirements of 4.1.5 and 6.10.2.2 are fulfilled and that an ALR sentence with alarm ID 1 is sent to the PI.

14.6.2.2 Antenna VSWR

14.6.2.2.1 Method of measurement

Prevent the EUT from radiating with full power by mismatching the antenna for a VSWR of 3:1. During the mismatch the output power is not required to be the rated output power.

14.6.2.2.2 Required results

Verify that the EUT continues operating. Verify that an alarm sentence ALR with alarm ID 002 is sent and the relay output signals the failure state.

Verify that relay deactivates when the EUT receives an ACK and that the status field in the ALR sentence is updated.

14.6.2.3 Rx malfunction

Manufacturers shall provide documentation describing how the AIS detects Rx malfunction and that an ALR sentence with alarm ID as appropriate is sent.

14.6.2.4 Loss of UTC

14.6.2.4.1 Method of measurement

Set up standard test environment and operate EUT in autonomous mode.

- a) Disconnect the GNSS antenna (UTC synch invalid).
- b) Reconnect the GNSS antenna.

14.6.2.4.2 Required results

Verify that:

- a) the system continues to operate and changes sync state to indirect synchronisation and that a ALR sentence with ID 007 is sent and the relay output is activated.
- b) the EUT outputs ALR sentence ID 007 with status deactivated and the relay output is deactivated. The EUT shall change sync state to UTC direct synchronisation.

14.6.2.5 Remote MKD disconnection, when so configured

14.6.2.5.1 Method of measurement

Set up standard test environment and operate EUT in autonomous mode.

- a) Disconnect the remote MKD or stop the HBT sentence.
- b) Provide an alarm acknowledgement, ACK sentence with ID 008, to the PI.
- c) Reconnect the remote MKD, apply the HBT sentence with status indication ok.
- d) Apply the HBT sentence with status indication not ok.
- e) Apply SSD sentence with DTE flag set to 1.

14.6.2.5.2 Required results

Verify that:

- a) after two times the specified repeat interval defined in HBT plus 1 s that an alarm sentence, alarm ID 008, is sent and the relay output signals the failure. Verify that the AIS continues operation, with the DTE value "1" in Message 5; If the configured repeat interval field is null, treat it as 30 s.
- b) the relay deactivates when the EUT receives an ACK and that the status field in the ALR sentence is updated;

- c) the AIS continues operation with the DTE value set to “0”;
- d) an alarm sentence, alarm ID 008, is sent and the relay output signals the failure. Verify that the AIS continue operation, with the DTE value "1" in Message 5;
- e) the AIS uses the DTE parameter in the SSD sentence and continues operation with the DTE value set to “1”.

14.6.2.6 Status query

14.6.2.6.1 Method of measurement

Set up standard test environment and operate EUT in autonomous mode.

Send a query sentence to the EUT (\$xxAIQ,TXT).

14.6.2.6.2 Required results

Verify that a set of TXT sentences representing the current status is output on the PI.

14.6.3 Monitoring of sensor data

14.6.3.1 Priority of position sensors

14.6.3.1.1 Method of measurement

Set up standard test environment and operate EUT in autonomous mode. Verify the manufacturer’s documentation to ascertain the configuration implemented on the EUT for position sensors.

Apply position sensor data in a way that the EUT operates in the states defined below:

- a) external DGNSS in use (corrected);
- b) internal DGNSS in use (corrected; Message 17) if implemented;
- c) internal DGNSS in use (corrected; beacon) if implemented;
- d) external EPFS in use (uncorrected);
- e) internal GNSS in use (uncorrected) if implemented;
- f) no sensor position in use.

Check the ALR sentence and the position accuracy flag in the VDL Message 1.

14.6.3.1.2 Required results

Verify that the use of position source, position accuracy flag, RAIM flag and position information complies with Table 4 and Table 5. Verify that the “type of electronic fixing device” in Message 5 is set accordingly.

Verify that when the status is changed, an ALR (025, 026, 029, 030), or TXT (021, 022, 023, 024, 025, 027, 028) sentence is sent according to Table 2 or Table 3, respectively.

Verify that the status is changed after 5 s when switching downwards and 30 s when switching upwards.

14.6.3.2 Multiple Message 17 from different DGNSS reference stations

14.6.3.2.1 Method of measurement

Set up standard test environment and operate EUT in autonomous mode.

When applying Message 17, use a base station MMSI as follows:

- a) Apply Message 17 from a distant DGNSS reference station.
- b) Apply Message 17 from a near DGNSS reference station in addition to the distant station.
- c) Switch off Message 17 from the near DGNSS reference station.

14.6.3.2.2 Required results

Verify the following:

- a) the use Message 17 for position determination;
- b) the use Message 17 from the near DGNSS reference station;
- c) the use Message 17 from the distant DGNSS reference station.

14.6.3.3 Heading sensor

14.6.3.3.1 Method of measurement

Set up standard test environment and operate EUT in autonomous mode.

- a) Disconnect the inputs for HDG and ROT or set their data to invalid (for example by wrong checksum, "valid/invalid" flag).
- b) Reconnect the inputs for HDG and ROT.
- c) Disconnect the input for ROT or set the data to invalid (for example by wrong checksum, "valid/invalid" flag). Establish a rate of heading change that is greater than 5° in 30 s.
- d) Reconnect the ROT input.
- e) Apply a SOG less than 5 kn and a difference between COG and HDT greater than 45° for 5 min.
- f) Apply a SOG greater than 5 kn and a difference between COG and HDT greater than 45° for 5 min.

14.6.3.3.2 Required results

Check that:

- a) an alarm sentence ALR with alarm ID 032 for invalid HDG and an alarm sentence ID 035 for invalid ROT are sent to the PI and the "default" data is sent in VDL Message 1, 2, or 3;
- b) an alarm sentence ALR with alarm ID 032 for valid HDG and ID 035 for valid ROT is sent to the PI. Verify that, in the alarm sentences, the alarm condition flag is set to "V" and that the relay output is not activated;
- c) Verify that TXT sentences with ID 031 for valid HDG and ID 033 for ROT indicator in use are sent to the PI;
- d) a TXT sentence with ID 034 for "other ROT source in use" is sent to the PI and that the contents of the message's ROT field is the correct "direction of turn" (Table 6 "ROT sensor fall-back conditions" Priority 2);
- e) a TXT sentence with ID 033 for ROT indicator in use and an ALR sentence with ID 035 for valid ROT is sent to the PI, and the alarm condition flag is set to "V" and that the relay output is not activated;
- f) no active alarm ID 011 for heading sensor offset is sent to the PI;
- g) an alarm sentence ALR with alarm ID 011 for heading sensor offset is sent to the PI after 5 min.

14.6.3.4 Speed sensors

14.6.3.4.1 Method of measurement

Set up standard test environment and operate EUT in autonomous mode. Verify the manufacturer's documentation to ascertain the configuration implemented on the EUT for position sensors (see 6.10) as follows:

- a) apply valid external DGNSS position and external speed data;
- b) disconnect external DGNSS position, disconnect the inputs for SOG, COG or set their data to invalid (e.g. by wrong checksum, "valid/invalid" flag).

14.6.3.4.2 Required results

Check that

- a) a TXT sentence with ID 027 is sent to the PI and the external data for SOG / COG is sent in VDL Message 1, 2 or 3. Verify that the system continues to operate and that the relay output is not activated;
- b) a TXT sentence with ID 028 is sent to the PI and the internal data for SOG / COG is sent in VDL Message 1, 2 or 3. Verify that the system continues to operate and that the relay output is not activated.

14.6.3.5 GNSS position mismatch

14.6.3.5.1 Method of measurement

Set up standard test environment and operate EUT with valid internal position available and using valid external position.

- a) Apply an external position with an offset of more than 100 m to the internal position for 3 min. Then modify external position to an offset of less than 100 m to the internal position.
- b) Modify the external position to an offset of more than 100 m to the internal position for more than 1 h.
- c) Then modify external position to an offset of less than 100 m to the internal position.

14.6.3.5.2 Required results

Check that

- a) no alarm sentence ALR is output,
- b) an alarm sentence ALR with alarm ID 009 with status active is output 15 min after the modification of the position,
- c) the alarm sentence ALR with alarm ID 009 with status inactive is output.

14.6.3.6 Incorrect NavStatus

14.6.3.6.1 Method of measurement

Set up standard test environment and operate EUT with valid internal position available and using valid external position then proceed as follows:

- a) Set NavStatus to "at anchor" and set SOG to > 3 kn.
- b) Repeat test with NavStatus "moored".
- c) Repeat test with NavStatus "aground".
- d) Set NavStatus to "under way" and set SOG to 0 kn for more than 2 h.
- e) Try to set NavStatus to 14.

14.6.3.6.2 Required results

Check that:

- a) an ALR sentence with ID 010 is generated. Verify that the system transmits with the reporting interval as appropriate, and that the MKD prompts the user to correct the NavStatus;
- b) an ALR sentence with ID 010 is generated. Verify that the system transmits with the reporting interval as appropriate;
- c) an ALR sentence with ID 010 is generated. Verify that the system transmits with the reporting interval as appropriate;
- d) an ALR sentence with ID 010 is generated after two hours. Verify that the system transmits with the reporting interval as appropriate, and that the MKD prompts the user to correct the NavStatus;
- e) setting of NavStatus 14 is rejected.

14.7 Display, input and output

(See 6.11)

14.7.1 Data input/output facilities

14.7.1.1 Method of measurement

Set up standard test environment and operate EUT in autonomous mode.

- a) Check the MKD indication and, by inspection, check that it is possible to input the entire 6-bit ASCII character set required by Recommendation ITU-R M.1371-4, Table 44.
- b) Record received messages and check contents of minimum display.
- c) Input static and voyage related data including the “<” and “>” brackets in the destination field via the MKD. Consider the full range of input fields, e.g. minimum and maximum.
- d) Record transmitted messages and check contents of MKD.

14.7.1.2 Required results

Confirm that:

- a) the minimum display contains at least three lines of target data, with no horizontal scrolling of elapsed time and the range and bearing data display and that the entire 6-bit character set is supported;
- b) all messages of Table 7 are displayed and that means to select messages and data fields to be displayed are available;
- c) all necessary data can be input. Verify that the access to input data required to be protected by section 6.11 is password protected. Check that all data not defined in 6.11 has a different password level or no password;
- d) all transmitted data is displayed correctly.

14.7.2 Initiate message transmission

14.7.2.1 Method of measurement

Set up standard test environment and operate EUT in autonomous mode.

Initiate the transmission of non-scheduled messages and interrogations as provided by the EUT.

14.7.2.2 Required results

Confirm that at least the transmission of safety-related addressed and broadcast messages (Message 12 and Message 14) can be initiated by means of the minimum display. Confirm that transmission of Messages 4, 9, 16, 17, 18, 19, 20, 21, 22, and 23 is not possible.

Confirm, by inspection of manufacturer's documentation, that pre-configured safety related text Messages 12 and 14 are not available.

NOTE Use of Messages 4, 9, 16, 17, 18, 19, 20, 21, 22, and 23 is restricted to other types of AIS stations.

14.7.3 Communication test

14.7.3.1 Method of measurement

Set up standard test environment and operate EUT in autonomous mode. The test environment has to include at least one Class B SO station. Initiate the communication test function (transmit Message 10) by

- a) MKD using proposed target;
- b) MKD using alternative target;
- c) AIR sentence;
- d) another transmitter (EUT as destination)

14.7.3.2 Required results

Confirm that:

- a) the EUT transmits Message 10 addressed to the target and that the communication test result is correct for both a successful and unsuccessful response on the MKD Verify that only Class A stations are proposed on the MKD
- b) the EUT transmits Message 10 addressed to the target and that the communication test result is correct for both a successful and unsuccessful response on the MKD. Verify that only Class A stations can be selected as alternative targets on the MKD;
- c) the EUT transmits Message 10 addressed to the target;
- d) the EUT transmits Message 11 as the response.

In all cases verify that VDO Message 10 and received VDM Message 11 is output to the PI.

Verify that Class B stations are not selected by the MKD.

14.7.4 System control

14.7.4.1 Method of measurement

Set up standard test environment and operate EUT in autonomous mode. Perform system control/configuration commands as specified. Check indication of system status/alarms.

14.7.4.2 Required results

Confirm that the configuration level and other functions, not intended for use by the operator, are protected by password or adequate means.

Verify that regional channel management settings can be input via the MKD and that there is no other means of changing the radio parameters.

14.7.5 Display of received targets

14.7.5.1 Method of measurement

Set up standard test environment and operate EUT in autonomous mode.

- a) Apply messages from the following targets to the VDL:
 - Class A with Messages 1 and 5, 10 s reporting interval;
 - Class A with Messages 3 and 5, 3 min reporting interval;
 - Base station with Message 4, 10 s reporting interval;
 - Airborne AIS with Messages 9 and 5, 10 s reporting interval;
 - Class B SO with Messages 18 and 19, 30 s reporting interval;
 - Class B CS with Messages 18 and 24A,B, 3 min reporting interval;
 - AIS AtoN with Message 21, 1 min reporting interval;
 - AIS-SART under test with Messages 1 and 14, 1 TDMA burst;
 - AIS-SART under test with Messages 1 and 14, 1 TDMA burst with enabling testing AIS-SART indication;
 - 2 active AIS-SARTs with Messages 1, 1 min reporting interval.
- b) Remove all targets from VDL.
- c) Apply again all targets after 17 min, without static data Messages 5, 19 and 24.
- d) Switch off one AIS-SART.
- e) Apply 200 targets to the EUT.
- f) Apply 300 targets to the EUT.

14.7.5.2 Required results

The following results are required:

- a) Confirm that all targets are displayed on the target list with name, range, bearing and minutes from last received position report.
 Confirm that the nearest active AIS-SART is displayed on top of the list and the name is SART ACTIVE.
 Confirm that an Alarm ID 014 is sent to the PI.
 Confirm that testing AIS-SART is not displayed; however, it is displayed only when enabling testing AIS-SART indication.
 Confirm that the other targets are displayed in an order according to the range, nearest target first.
 Confirm that all targets can be selected for detailed view.
 Confirm that all information required by Table 7 is displayed in the detailed view if not displayed in the target list.
 Confirm that all target information which is displayed on the MKD is displayed correctly.
- b) Confirm that the time from the last received message is counting down every minute for all targets. Confirm that all targets except the active AIS-SARTs are removed from display 7 min after the last received message.
- c) Confirm that all targets are displayed again. Confirm that all static data from all targets are displayed correctly.
- d) Confirm that the time from the last received message is counting down every minute for AIS-SART. Confirm that the AIS-SART is removed from display 18 min after the last received message.
- e) Confirm that the MKD displays 200 targets.
- f) Confirm that the MKD displays 200 nearest targets as a minimum.

14.7.6 Display of position quality

14.7.6.1 Method of measurement

Set up standard test environment and operate EUT in autonomous mode.

Apply Class A transmissions with the following data to the VDL and observe the position quality display on the MKD:

- a) Time stamp = 63;
- b) Time stamp = 61;
- c) Time stamp = 62;
- d) Time stamp = 60
- e) Time stamp 0... 59, PA = 0, RAIM = 0;
- f) PA = 0, RAIM = 1;
- g) PA = 1, RAIM = 0;
- h) PA = 1, RAIM = 1;
- i) Set SOG = 10 kn, then stop target transmissions;
- j) Start transmission again, set SOG = 20 kn, then stop transmission.

14.7.6.2 Required results

Confirm that:

- a) the position quality "No position" is displayed;
- b) the position quality "Manual position" is displayed;
- c) the position quality "Dead reckoning position" is displayed;
- d) the position quality "valid position with no time stamp" is displayed;
- e) the position quality "Position > 10m" is displayed;
- f) the position quality "Position with RAIM > 10 m" is displayed;
- g) the position quality "Position < = 10 m" is displayed;
- h) the position quality "Position with RAIM < = 10 m" is displayed;
- i) 40 s after the last transmission the position quality is changed to "Outdated position > 200 m";
- j) 20 s after the last transmission the position quality is changed to "Outdated position > 200 m".

14.7.7 Display of targets if optional filter is implemented

The methods of test and the required results are as follows:

- a) confirm by observation that the user can filter the presentation of AIS targets according to the manufacturer's documentation;
- b) confirm by observation that an indication is provided when sleeping targets are filtered from the presentation according to the manufacturer's documentation;
- c) confirm by observation that the indication remains while the filter is active according to the manufacturer's documentation;
- d) confirm by observation that the filter criteria in use is readily available according to the manufacturer's documentation;
- e) confirm by observation that the user cannot remove individual AIS targets from the presentation according to the manufacturer's documentation .

14.7.8 Display of received safety related messages

14.7.8.1 Method of measurement

Set up standard test environment and operate EUT in autonomous mode.

- a) Transmit 20 Message 12 addressed to the EUT.
- b) Acknowledge displayed message on the MKD.
- c) Transmit 20 Message 12 addressed to the EUT.
- d) Transmit Message 14.

14.7.8.2 Required results

Confirm that:

- a) the most recently received Message 12 is displayed foremost and all 20 messages are available for display;
- b) the acknowledged Message 12 is removed from foremost display on the MKD;
- c) the most recently received Message 12 is displayed foremost and all 20 messages are available for display;
- d) there is an indication that the Message 14 has been received and that Message 14 is available for display.

14.7.9 Presentation of navigation information

Verify compliance with the general requirements for the presentation of navigation-related information in accordance with the test methods and required results specified in IEC 62288.

Verify compliance with requirements for graphical presentation of targets in accordance with the test methods and required results of IEC 62288, if display of graphical symbols for AIS data is provided.

Provide input of the messages listed below and confirm by observation that the MKD displays graphical symbology as described in IEC 62288, if display of graphical symbols for AIS data is provided:

- Messages 1, 2, 3 and 5 (Class A AIS, AIS-SART);
- Messages 18, 19 and 24 (Class B AIS);
- Message 4 (AIS Base Stations);
- Message 9 (AIS on Airborne SAR-craft);
- Message 21 (AIS AtoN).

Symbols not described in IEC 62288 may be defined by the manufacturer.

Verify compliance in accordance with the test methods and required results of IEC 62388 (Radar) for calculation of CPA/TCPA, if provided.

15 Physical tests

(See 7.2)

NOTE Unless otherwise stated, all transmitter tests are performed at the highest power setting.

At all test frequencies the carrier power shall be within $\pm 3,0$ dB of its nominal power levels under extreme test conditions.

15.1.3 Slotted transmission spectrum

15.1.3.1 Definition

This test is to ensure that the modulation and transient sidebands produced by the transmitter under normal operating conditions fall within the allowable mask.

15.1.3.2 Method of measurement

The test shall use test signal number 4. The EUT shall be connected to a spectrum analyser. A resolution bandwidth of 300 Hz, video bandwidth of 3 kHz or greater and positive peak detection (maximum hold) shall be used for this measurement. A sufficient number of sweeps shall be used and sufficient transmission packets measured to ensure that the emission profile is developed. Tests shall be performed on 2 channels (156,025 MHz, 162,025 MHz).

15.1.3.3 Required results

The spectrum for slotted transmission shall be within the emission mask as follows:

- in the region between the carrier and ± 10 kHz removed from the carrier, the modulation and transient sidebands shall be below 0 dBc;
- at ± 10 kHz removed from the carrier, the modulation and transient sidebands shall be below -25 dBc;
- at ± 25 kHz to $\pm 62,5$ kHz removed from the carrier, the modulation and transient sidebands shall be below the lower value of -70 dBc;
- in the region between ± 10 kHz and ± 25 kHz removed from the carrier, the modulation and transient sidebands shall be below a line specified between these two points.

The reference level for the measurement shall be the carrier power (conducted) recorded for the appropriate test frequency in 15.1.2.

For information the emission mask specified above is shown in Figure 6.

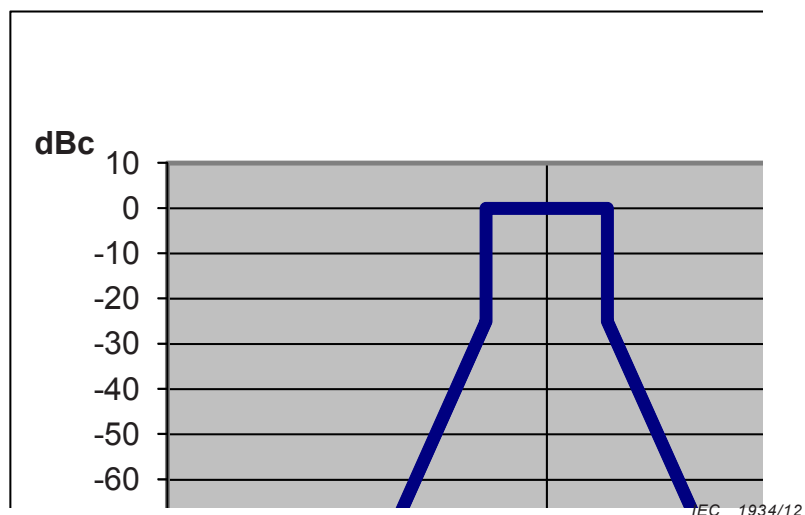

Figure 6 – Emission mask for slotted transmission

15.1 TDMA transmitter

15.1.1 Frequency error

15.1.1.1 Definition

The frequency error of the transmitter is the difference between the measured carrier frequency in the absence of modulation of the transmitter and its required frequency.

15.1.1.2 Method of measurement

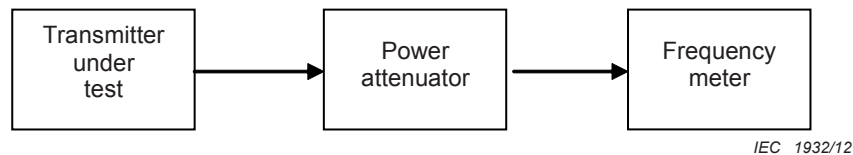

Figure 4 – Measurement arrangement for frequency error

The carrier frequency shall be measured in the absence of modulation (see Figure 4). Tests shall be performed on 2 channels (156,025 MHz, 162,025 MHz) and under normal and extreme test conditions.

15.1.1.3 Required results

The frequency error shall not exceed $\pm 0,5$ kHz under normal and ± 1 kHz under extreme test conditions.

15.1.2 Carrier power

15.1.2.1 Definition

The transmitter carrier power conducted (P_c) is defined as the mean power delivered to a nominal 50Ω load during a transmission slot.

15.1.2.2 Method of measurement

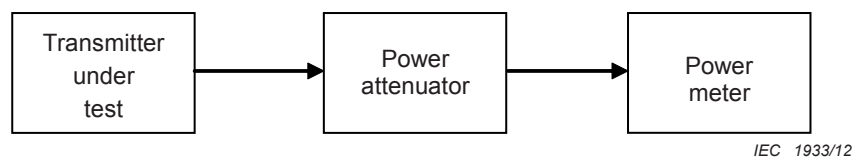

Figure 5 – Measurement arrangement for carrier power

The equipment shall be connected as in Figure 5. Tests shall be performed on 2 channels (156,025 MHz, 162,025 MHz) under normal and extreme test conditions.

The tests shall be repeated for the power levels stated in 7.2.2.

15.1.2.3 Required results

At all test frequencies, the carrier power shall be within $\pm 1,5$ dB of its nominal power levels under normal test conditions.

15.1.4 Modulation accuracy

15.1.4.1 Definition

The modulation accuracy is the measurement of the peak frequency deviation of the transmitter modulation and the correct implementation of the Gaussian minimum shift keying (GMSK) bandwidth-time (BT) filtering.

15.1.4.2 Method of measurement

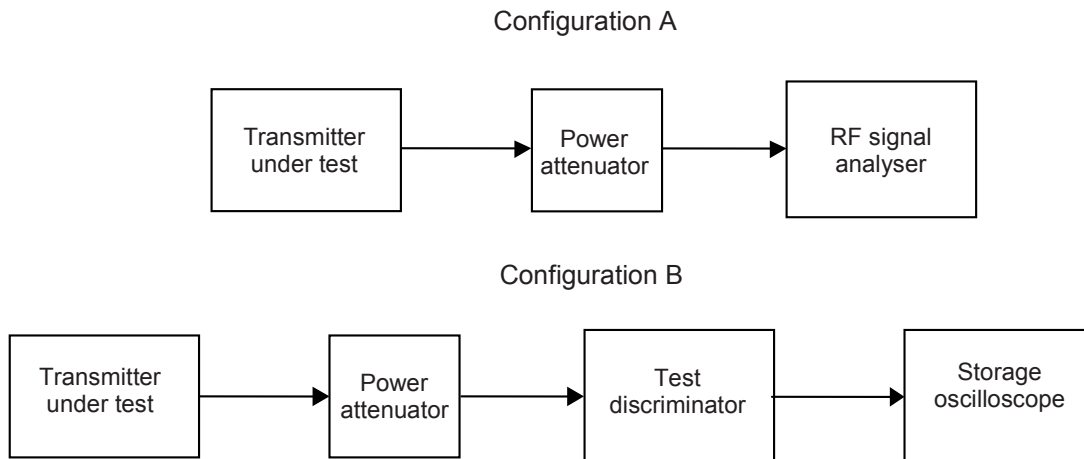

IEC 1935/12

Figure 7 – Measurement arrangement for modulation accuracy

The equipment shall be connected in either configuration A or configuration B as shown in Figure 7. The tests shall be performed on 2 channels (156,025 MHz, 162,025 MHz) under normal and extreme test conditions.

The transmitter shall be modulated with test signal number 2.

The transmitter shall be modulated with test signal number 3.

15.1.4.3 Required results

Peak deviation shall be as per Table 22.

Table 22 – Peak frequency deviation versus time

Test signal 2		Test signal 3	
Normal	Extreme	Normal	Extreme
1 740 Hz ± 175 Hz	1 740 Hz ± 350 Hz	2 400 Hz ± 240 Hz	2 400 Hz ± 480 Hz

15.1.5 Transmitter output power characteristics

15.1.5.1 Definition

Transmitter output power characteristics are a combination of the transmitter delay, ramp-up time, ramp-down time and transmission duration, as specified in 7.2.2, where:

Transmitter delay (T_A) is the time between the start of the candidate transmission time period and the time when the transmission power exceeds -50 dBc;

Transmitter ramp-up time ($T_B - T_A$) is the time between the transmit power exceeding -50 dBc and the moment when the transmit power has reached a level 1 dB below the measured steady-state power (P_{SS}) and maintains a level within $+1,5/-1$ dB from P_{SS} thereafter;

Transmitter ramp-down time ($T_F - T_E$) is the time between the end flag being transmitted and the moment when the transmitter output power has reduced to a level 50 dB below P_{SS} and remains below this level thereafter;

Transmission duration ($T_F - T_A$) is the time from when power exceeds -50 dBc to when the power returns to and stays below -50 dBc.

15.1.5.2 Method of measurement

The measurement shall be carried out by transmitting test signal number 4 (note that this test signal generates one additional stuffing bit within its CRC portion). Tests shall be performed on 2 channels (156,025 MHz, 162,025 MHz). The EUT shall be connected to a spectrum analyser. A resolution bandwidth of 1 MHz, video bandwidth of 1 MHz and a sample detector shall be used for this measurement. The analyser shall be in zero-span mode for this measurement. The spectrum analyser shall be synchronised to the nominal start time of the slot (T_0), which may be provided externally, or from the EUT.

15.1.5.3 Required results

The transmitter power shall remain within the mask shown in Figure 2 and associated timings given in Table 10.

15.2 TDMA receivers

15.2.1 Sensitivity

15.2.1.1 Definition

The usable sensitivity is the minimum level of signal at the receiver input, produced by a carrier at the nominal frequency of the receiver, modulated with a test signal, which will, without interference, produce after demodulation a data signal with a specified packet error rate (PER).

15.2.1.2 Method of measurement

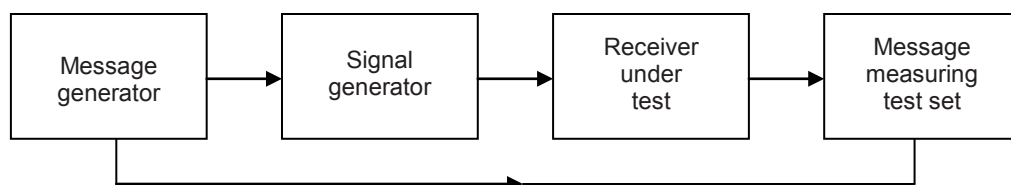

IEC 1936/12

Figure 8 – Measurement arrangement

The signal generator (see Figure 8) shall be at the nominal frequency of the receiver and shall be modulated to generate test signal number 5. The signal level at the input of the receiver shall be set to -107 dBm. The message measuring test set shall be monitored and the packet error rate observed. The PER shall be derived by the following formula:

$$PER = (P_{TX} - P_{RX})/P_{TX} \times 100 (\%)$$

where

P_{RX} is the number of packets received without errors;

P_{TX} is the number of transmitted packets.

Tests shall be performed on 2 channels (156,025 MHz, 162,025 MHz) with a signal level of -107 dBm and repeated at $156,025$ MHz \pm 500 Hz and $162,025$ MHz \pm 500 Hz with the level at the input to the receiver adjusted to -104 dBm under normal conditions.

Repeat under extreme conditions at nominal frequencies, with the signal generator adjusted to -101 dBm.

15.2.1.3 Required results

The PER shall not exceed 20 %.

15.2.2 Error behaviour at high input levels

15.2.2.1 Definition

The error behaviour (performance) at high input levels (noise free operation) is defined in the same manner as for the measurement of the maximum usable sensitivity when the level of the wanted signal is significantly above the maximum wanted sensitivity.

15.2.2.2 Method of measurement

The measurement configuration for receiver sensitivity (15.2.1) shall be used. Tests shall be performed on 2 channels (156,025 MHz, 162,025 MHz). The signal generator shall be at the nominal frequency of the receiver and shall be modulated to generate test signal number 5. The level of the input signal shall be adjusted to a level of -7 dBm. The message measuring test set shall be monitored and the packet error rate observed. This test shall be repeated at the level of -77 dBm.

15.2.2.3 Required results

The PER shall not exceed 1 %.

15.2.3 Co-channel rejection

15.2.3.1 Definition

The co-channel rejection is a measure of the capability of the receiver to receive a wanted modulated signal without exceeding a given degradation due to the presence of an unwanted modulated signal, both signals being at the nominal frequency of the receiver.

15.2.3.2 Method of measurement

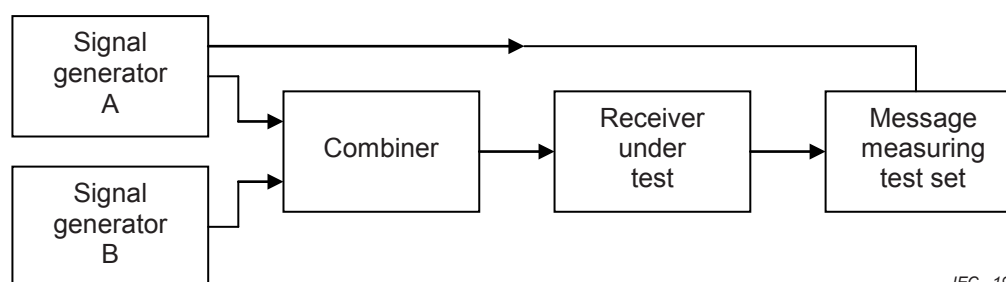

IEC 1937/12

Figure 9 – Measurement arrangement with two generators

Two generators, A and B, shall be connected to the receiver via a combining network as shown in Figure 9. The wanted signal, provided by signal generator A, shall be at the nominal frequency of the receiver and shall be modulated to generate test signal number 5. The unwanted signal, provided by generator B, shall also be at the nominal frequency of the receiver. Generator B shall be modulated to generate test signal number 4, either continuously or in the same time period as that used by generator A for test signal number 5. The content of the wanted and unwanted signals shall not be synchronised. The level of the wanted signal from generator A shall be adjusted to -104 dBm at the receiver. The level of the unwanted signal from generator B shall be adjusted to -114 dBm at the receiver. The message measuring test set shall be monitored and the packet error rate (PER) observed. The measurement shall be repeated for displacements of the unwanted signal of ± 1 kHz from the nominal frequency of the receiver and the PER again observed. Tests shall be performed on 2 channels (156,025 MHz, 162,025 MHz).

NOTE ± 1 kHz for the unwanted signal is twice the allowable transmit frequency tolerance.

15.2.3.3 Required results

The PER shall not exceed 20 %.

15.2.4 Adjacent channel selectivity

15.2.4.1 Definition

The adjacent channel selectivity is a measure of the capability of the receiver to receive a wanted modulated signal without exceeding a given degradation due to the presence of an unwanted signal which differs in frequency from the wanted signal by an amount equal to the adjacent channel separation for which the equipment is intended.

15.2.4.2 Method of measurement

The measurement configuration for co-channel rejection (15.2.3) shall be used. The wanted signal, provided by signal generator A, shall be at the nominal frequency of the receiver and shall be modulated to generate test signal number 5. The unwanted signal, provided by generator B, shall be frequency modulated with a 400 Hz sine wave giving a deviation of ± 3 kHz. Generator B shall be at a frequency 25 kHz above that of the wanted signal. The level of the wanted signal from generator A shall be adjusted to a level of -104 dBm at the receiver. The level of the unwanted signal from generator B shall be adjusted to -34 dBm. The message measuring test set shall be monitored and the packet error rate observed. Repeat the above measurement with the unwanted signal 25 kHz below the wanted signal.

The test shall be performed on 2 channels (156,025 MHz, 162,025 MHz) and repeated under extreme conditions with generator A adjusted to -98 dBm and generator B adjusted to -38 dBm.

15.2.4.3 Required results

The PER shall not exceed 20 %.

15.2.5 Spurious response rejection

15.2.5.1 Definition

The spurious response rejection is a measure of the capability of the receiver to receive a wanted modulated signal without exceeding a given degradation due to the presence of an unwanted modulated signal at any other frequency, at which a response is obtained.

15.2.5.2 Manufacturer's declarations

The manufacturer shall declare the following in order to calculate the "limited frequency range" over which the initial part of the test will be performed:

- list of intermediate frequencies: (IF_1, IF_2, \dots, IF_N) in Hz;
- switching range of the receiver;

NOTE 1 Switching range corresponds to the frequency range over which the receiver can be tuned.

- frequency of the local oscillator at 156,025 MHz and 162,025 MHz (AIS2): (f_{LOL}, f_{LOH}).

NOTE 2 This may be a VCO, crystal, sampling clock, BFO, or numerically controlled oscillator, depending on the design of the equipment.

15.2.5.3 Introduction to the method of measurement

The initial evaluation of the unit shall be performed over the "limited frequency range" and shall then be performed at the frequencies identified from this test and at "specific frequencies of interest" (as defined below).

If the EUT contains IF frequencies the following procedure applies. Otherwise the manufacturer shall provide an alternative procedure based on the design of the EUT that produces equivalent results. To determine the frequencies at which spurious responses can occur the following calculations shall be made:

- a) calculation of the "limited frequency range":

the limits of the limited frequency range (LFR_{HI}, LFR_{LO}) are determined by the following calculations:

$$LFR_{HI} = f_{LOH} + (IF_1 + IF_2 + \dots + IF_N + sr/2)$$

$$LFR_{LO} = f_{LOL} - (IF_1 + IF_2 + \dots + IF_N + sr/2)$$

- b) calculation of specific frequencies of interest (SFI) outside the limited frequency range:
these are determined by the following calculations:

$$SFI_1 = (K \times f_{LOH}) \pm IF_1$$

$$SFI_2 = (K \times f_{LOL}) \pm IF_1$$

where K is an integer from 2 to 4.

15.2.5.4 Method of measurement over the limited frequency range

Two methods are available for the measurements over the limited frequency range, one based on SINAD measurements and the other based on PER measurements. Either method may be used, but in each case shall be followed by the method of measurement at identified frequencies.

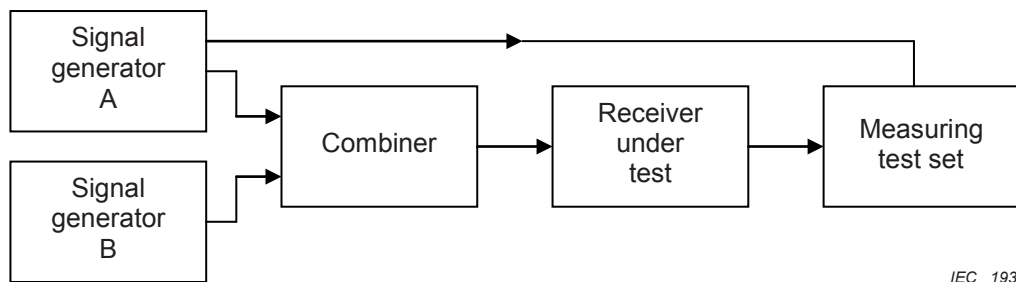

IEC 1938/12

Figure 10 – SINAD or PER/BER measuring equipment

15.2.5.5 Method of search over the "limited frequency range" using SINAD measurements

Two generators A and B shall be connected to the receiver via a combining network as shown in Figure 10. The wanted signal, provided by generator A, shall be 162,025 MHz (AIS 2) and shall be modulated with 1 kHz sine wave at $\pm 2,4$ kHz deviation. The unwanted signal, provided by generator B, shall be frequency modulated with a 400 Hz sine wave giving a deviation of ± 3 kHz.

Initially, generator B (unwanted) shall be switched off (maintaining the output impedance). The signal level from generator A (wanted) shall be adjusted to -104 dBm at the receiver. The SINAD value shall be noted (and should be greater than 14 dB). Signal generator B shall be switched on and adjusted to -27 dBm at the receiver. The frequency of the unwanted signal shall be varied in steps of 5 kHz over the limited frequency range (from LFR_{LO} to LFR_{HI}). The frequency of any spurious response detected (by a decrease in SINAD of 3 dB or more) during the search shall be recorded for use in the next measurements.

Set the receiving frequency to 156,025 MHz and repeat the test.

15.2.5.6 Method of search over the "limited frequency range" using PER or BER measurement

Two generators A and B, shall be connected to the receiver via a combining network as shown in Figure 10. The wanted signal, provided by generator A, shall be 162,025 MHz (AIS2) and shall be modulated to generate test signal number 5. The unwanted signal, provided by generator B, shall be frequency modulated with a 400 Hz sine wave giving a deviation of ± 3 kHz. Initially, generator B (unwanted) shall be switched off (maintaining the output impedance). The signal level from generator A (wanted) shall be adjusted to -104 dBm at the receiver. The PER or BER shall be noted.

Signal generator B shall be switched on and adjusted to -27 dBm at the receiver. The frequency of the unwanted signal shall be varied in steps of 5 kHz over the limited frequency range (from LFR_{LO} to LFR_{HI}). The frequency of any spurious response detected (by an increase in either PER or BER) during the search shall be recorded for use in the next measurements.

In the case where operation using a continuous packet stream is not possible a similar method may be used.

Set the receiving frequency to 156,025 MHz and repeat the test.

15.2.5.7 Method of measurement (at identified frequencies)

Two generators A and B shall be connected to the receiver via a combining network as shown in Figure 10. The wanted signal, provided by generator A, shall be 162,025 MHz (AIS2) and shall be modulated to generate test signal number 5. The unwanted signal, provided by

generator B, shall be frequency modulated with a 400 Hz sine wave giving a deviation of ± 3 kHz. Generator B shall be at the frequency of that spurious response being considered. Initially, generator B (unwanted) shall be switched off (maintaining the output impedance). The signal level from generator A (wanted) shall be adjusted to -104 dBm at the receiver. Generator B shall be switched on, and the level of the unwanted signal set to -34 dBm.

For each frequency noted during the tests over the limited frequency range on 162,025 MHz (AIS2) and the specific frequencies of interest (SFI_1), transmit 200 packets to the EUT and note the PER.

Set the receiving frequency to 156,025 MHz and repeat the test for each frequency noted during the tests over the limited frequency range on 156,025 MHz and the specific frequencies of interest (SFI_2).

15.2.5.8 Required results

At any frequency separated from the nominal frequency of the receiver by two channels or more, the spurious responses shall not result in a PER of greater than 20 %.

15.2.6 Intermodulation response rejection and blocking

15.2.6.1 Definition

The intermodulation response rejection and blocking is the capability of the receiver to receive a wanted modulated signal, without exceeding a given degradation due to the presence of two or more unwanted signals with a specific frequency relationship to the wanted signal frequency.

15.2.6.2 Method of measurement

Four signal generators shall be connected to the receiver under test (see Figure 11). The wanted signals, represented by signal generator A, shall be modulated to generate test signal number 5. The wanted signal level at the RF input of the receiver shall be set to -101 dBm.

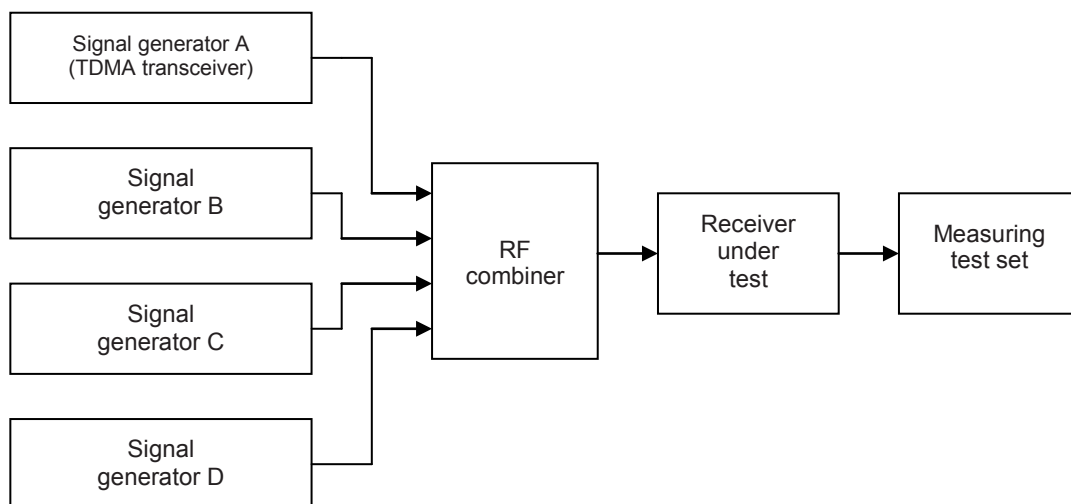

IEC 1939/12

Figure 11 – Test set-up

The unwanted signal from signal generator B shall be modulated by 400 Hz with a deviation of ± 3 kHz and adjusted to a frequency 500 kHz above or below the frequency of the wanted signal. The unwanted signal from signal generator C shall be unmodulated and adjusted to a frequency 1 000 kHz above or below the frequency of the wanted signal. The unwanted signal levels from signal generators B and C at the RF input of the receiver shall be set to -27 dBm.

The unwanted signal from signal generator D shall be unmodulated and adjusted to a frequency 5,725 MHz above or below the frequency of the wanted signal. The unwanted signal level from signal generator D at the RF input of the receiver shall be set to -15 dBm.

According to the Table 23, two tests (Test #1 and Test #2) shall be performed.

Table 23 – Tests to be performed

	Generator A	Generator B	Generator C	Generator D
Test #1	156,025	156,525	157,025	161,750
Test #2	162,025	161,525	161,025	156,300

15.2.6.3 Required results

The packet error rate shall not exceed 20 %.

15.2.7 Transmit to receive switching time

15.2.7.1 Definition

The transmit to receive switching time describes the capability of the TDMA receiver to receive in the slot immediately following the transmission slot.

15.2.7.2 Method of measurement

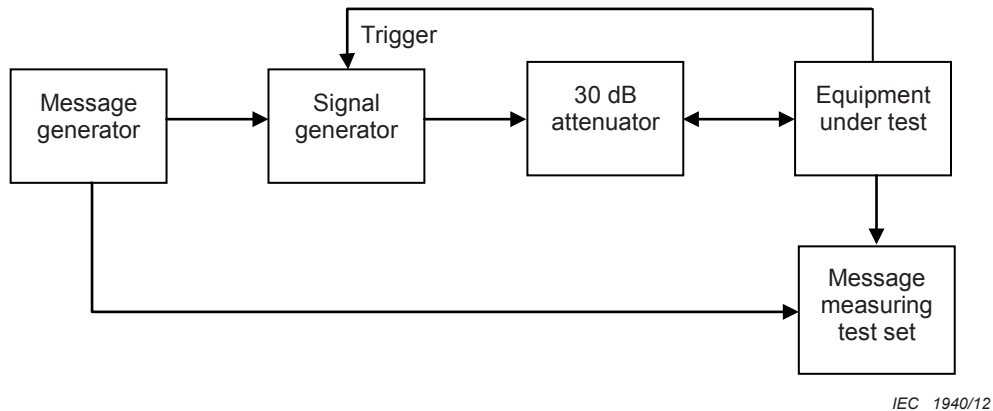

Figure 12 – Transmit to receive switching time measurement setup

The signal generator shall be connected to the EUT through 30 dB attenuator. The EUT shall be connected to a 30 dB attenuator. The transmit to receive control signal in the EUT shall be connected to the signal generator as the trigger signal to output the test message at the immediate slot after the EUT transmission. The signal generator shall be at the nominal frequency of the EUT with a signal level of -107 dBm at the EUT and shall be modulated to generate test signal number 5. The EUT shall be set to the default power (12,5 W) and be set to transmit 200 messages of Message 1 with 2 s interval. The message measuring test set shall be monitored and the PER be observed.

The test shall be performed on 2 channels (156,025 MHz, 162,025 MHz).

15.2.7.3 Required results

The PER shall not exceed 20 %.

15.2.8 Immunity to out-of-band energy

15.2.8.1 Definition

The immunity to out-of-band energy is the capability of the receiver to receive a wanted modulated signal, without exceeding a given degradation due to the presence of high level unwanted signals out of the maritime mobile band.

15.2.8.2 Method of measurement

Two generators A and B, shall be connected to the receiver via a combining network as shown in 15.2.3. The wanted signal, provided by signal generator A shall be initially at 162,025 MHz and be modulated to generate test signal number 5. The unwanted signal from generator B shall be unmodulated and tuned to 174 MHz. Initially, signal generator B (unwanted signal) shall be switched off (maintaining the output impedance). The level of the wanted signal from generator A shall be adjusted to -101 dBm at the receiver input. Generator B shall then be switched on, and the level of the unwanted signal set to -5 dBm. 200 packets shall be transmitted and the PER recorded.

Repeat the test with the wanted signal generator tuned to 156,025 MHz with the same unwanted signal.

15.2.8.3 Required results

The packet error rate shall not exceed 20 %.

15.3 Conducted spurious emissions

15.3.1 Spurious emissions from the transmitter

15.3.1.1 Definition

Conducted spurious emissions are emissions on a frequency or frequencies, which are outside the necessary bandwidth and the level of which may be reduced without affecting the corresponding transmission of information. Spurious emissions include harmonic emissions, parasitic emissions, intermodulation products and frequency conversion products, but exclude out-of-band emissions.

15.3.1.2 Method of measurement

The transmitter shall be connected to a 50Ω power attenuator. The output of the power attenuator shall be connected to a measuring receiver.

If possible, the measurement shall be made with the transmitter unmodulated. If this is not possible, the transmitter shall be modulated by test signal number 4. If possible the modulation should be continuous for the duration of the measurement.

The measurement shall be made over a frequency range from 9 kHz to 4 GHz, excluding the channel on which the transmitter is operating $\pm 62,5$ kHz.

The resolution bandwidth of the measuring instrument shall be the smallest bandwidth available which is greater than the spectral width of the spurious component being measured. This shall be considered to be achieved when the next highest bandwidth causes less than 1 dB increase in amplitude. Positive peak detection (maximum hold) shall be selected on the spectrum analyser used for this measurement.

A sufficient number of sweeps shall be measured to ensure that the emission profile is developed.

At each frequency at which a spurious component is detected, the power level shall be recorded as the conducted spurious emission level delivered into the specified load, except for the channel on which the transmitter is intended to operate and the adjacent two channels of upper and lower sides.

The conditions used in the relevant measurements shall be recorded in test reports.

15.3.1.3 Required results

The power of any spurious emission on any discrete frequency shall not exceed 0,25 μW (–36 dBm) in the frequency range 9 kHz to 1 GHz and 1 μW (–30 dBm) in the frequency range 1 GHz to 4 GHz.

15.3.2 Spurious emissions from the receiver

15.3.2.1 Definition

Spurious emissions from the receiver are components at any frequency, conducted to the antenna. The level of spurious emissions shall be measured as their power level in a specified load.

15.3.2.2 Method of measurement

The receiver shall be connected to a 50 Ω attenuator. The output of the attenuator shall be connected to a spectrum analyser or selective voltmeter having an input impedance of 50 Ω . If the detecting device is not calibrated in terms of power input, the level of any detected components shall be determined by a substitution method using a signal generator. The measurement shall extend over the frequency range 9 kHz to 4 GHz.

The receiver shall be switched on, and the measuring receiver shall be tuned over the frequency range 9 kHz to 4 GHz.

At each frequency at which a spurious component is detected, the power level shall be recorded as the spurious level delivered into the specified load.

15.3.2.3 Required results

The power of any spurious emission in the specified range at the antenna terminal shall not exceed –57 dBm (2 nW) in the frequency range 9 kHz to 1 GHz and –47 dBm (20 nW) in the frequency range 1 GHz to 4 GHz.

16 Specific tests of link layer

(See 7.3)

NOTE In this clause “CommState” is used as an abbreviation for “communication state” as defined in Recommendation ITU-R M.1371-4. Communication state is structured with a number of parameters for “Sync state”, “Slot time-out”, “Slot increment”, “Number of slots”, “Sub-message (Received stations, slot number, UTC hour and minute, slot offset)”, and “Keep flag”.

16.1 TDMA synchronisation

16.1.1 Synchronisation test using UTC

16.1.1.1 Method of measurement

Set up standard test environment; choose test conditions in a way that the EUT operates in the following synchronisation modes:

a) UTC direct;

- b) UTC indirect (internal GNSS receiver disabled; at least one other station UTC direct synchronised);
- c) UTC indirect (internal GNSS disabled; base station with UTC direct synchronisation within range). Verify that the correct UTC date and time is derived from Message 4 of the base station;
- d) base direct (internal GNSS disabled; base station with semaphore qualified within range)
- e) UTC indirect (internal GNSS receiver disabled; only Class B station UTC direct synchronised).

Check CommState parameter Sync state in position report and reporting interval.

16.1.1.2 Required results

Confirm that:

- a) the SynchState = 0;
- c) the SynchState = 1;
- d) the SynchState = 1;
- e) the SynchState = 2;
- f) the EUT does not synchronise to the Class B station, SynchState = 3.

16.1.2 Synchronisation test using UTC with repeated messages

16.1.2.1 Method of measurement

Set up a test environment where all messages have a SyncState 0; choose test conditions in a way that the EUT operates in the following synchronisation modes:

- a) UTC direct;
- b) UTC indirect (internal GNSS receiver disabled; at least one other station UTC direct synchronised);
- c) UTC indirect (internal GNSS receiver disabled; all other stations UTC direct synchronised and syncstate 0, repeat indicator 1).

Check CommState parameter Sync state in position report and reporting interval.

16.1.2.2 Required results

The following results are required:

- a) transmitted communication state shall fit the synchronisation mode;
- b) the EUT shall synchronise to the other station;
- c) the EUT shall go to syncstate 3.

16.1.3 Synchronisation test without UTC, semaphore

16.1.3.1 Method of measurement

Set up standard test environment without UTC available. Let EUT be semaphore qualified (sync mode 1 or 3) as follows:

- a) Simulate other semaphore qualified stations with a different number of received stations.
- b) Simulate other semaphore qualified stations with the same number of received stations.

Check CommState parameter Sync state in position report and reporting interval.

16.1.3.2 Required results

Transmitted CommState shall fit the synchronisation mode. Check that

- a) EUT acts as semaphore only if it has the highest number of received stations,
- b) EUT acts as semaphore only if it has the lowest MMSI.

The EUT shall decrease reporting interval to 2 s when acting as a semaphore and shall remain in this state until the semaphore qualifying conditions have been invalid for 3 min.

16.1.4 Synchronisation test without UTC

16.1.4.1 Method of measurement

Set up standard test environment; choose test conditions in a way that EUT operates in following sync modes:

- a) base indirect (internal GNSS disabled; no station with UTC direct synchronisation or base station within range);
- b) mobile indirect (internal GNSS disabled; other station with UTC direct synchronisation or base station without range);
- c) internal GNSS enabled in synchronisation modes other than UTC direct.

Check CommState parameter sync state in position report and reporting interval.

16.1.4.2 Required results

The following results are required:

- a) transmitted communication state shall fit the synchronisation mode;
- b) transmitted communication state shall fit the synchronisation mode;
- c) synchronisation mode shall revert to UTC direct.

16.1.5 Reception of un-synchronised messages

16.1.5.1 Method of measurement

Set up standard test environment and operate EUT in UTC direct mode.

Transmit un-synchronised test messages (more than ± 10 ms away from the slot boundary).

16.1.5.2 Required results

Verify that the transmitted test messages are received and processed.

16.2 Time division (frame format)

16.2.1 Method of measurement

Set the EUT to reporting interval of 2 s by applying a speed of > 23 kn and a ROT of $> 20^\circ/s$. Record VDL messages and check for used slots. Check parameter slot number in CommState of position report. Check slot length (transmission time).

16.2.2 Required results

Slot number used and slot number indicated in CommState shall match. Slot number shall not exceed 2 249. Slot length shall not exceed 26,67 ms.

16.3 Synchronisation and jitter accuracy

16.3.1 Definition

Synchronisation jitter (transmission timing error) is the time between nominal slot start as determined by the UTC synchronisation source and the initiation of the "transmitter on" function (T_0 see Recommendation ITU-R M.1371-4/A2-3.2.2.10, Figure 8).

16.3.2 Method of measurement

Set up standard test environment, reporting interval of 2 s and using

- a) UTC direct synchronisation,
- b) UTC indirect synchronisation by disconnecting the GNSS antenna of the EUT.

Record VDL messages and measure the time between the nominal beginning of the slot interval and the initiation of the "transmitter on" function. Alternative methods, for example by evaluating the start flag and calculating back to T_0 are allowed.

16.3.3 Required results

The synchronisation, including its jitter, shall not exceed

- a) $\pm 104 \mu\text{s}$ using UTC direct synchronisation,
- b) $\pm 312 \mu\text{s}$ relative to the synchronisation source using UTC indirect synchronisation.

16.4 Data encoding (bit stuffing)

16.4.1 Method of measurement

Set up standard test environment as follows:

- a) Apply a binary broadcast message (Message 8) to the VDL containing the HEX-values "7E 3B 3C 3E 7E" in the data portion and check presentation interface output of EUT.
- b) Apply a BBM sentence to the EUT initiating the transmission of Message 8 containing the HEX-values as above in the data portion and check the VDL.

16.4.2 Required results

Confirm that

- a) data output on the presentation interface conforms to transmitted data,
- b) transmitted VDL message conforms to data input on the presentation interface.

16.5 Frame check sequence

16.5.1 Method of measurement

Apply a simulated position report message with wrong CRC bit sequence to the VDL.

16.5.2 Required results

Confirm that by observing the MKD and by inspecting the PI output that this message is not processed.

16.6 Slot allocation (channel access protocols)

16.6.1 Network entry

16.6.1.1 Method of measurement

Set up standard test environment; switch on EUT. Record transmitted scheduled position reports for the first 3 min of transmission after initialization period. Check CommState for channel access mode.

16.6.1.2 Required results

EUT shall start autonomous transmissions of Message 3 (position report) with ITDMA CommState with KeepFlag set true for the first minute of transmission and Message 1 with SOTDMA CommState thereafter.

16.6.2 Autonomous scheduled transmissions (SOTDMA)

16.6.2.1 Method of measurement

Set up standard test environment and operate EUT in autonomous mode as follows:

- a) Record transmitted scheduled position reports Message 1 and check frame structure. Check CommState of transmitted messages for channel access mode and parameters number of received stations, slot timeout, slot number and slot offset.
- b) Repeat the test with 50 % channel loading ensuring there are at least 4 free slots in each SI.
- c) Repeat the test with 50 % channel loading by message 26 ensuring there are at least 4 free slots in each SI.

16.6.2.2 Required results

Check that

- a) nominal reporting interval is achieved ± 20 % (allocating slots in selection interval SI). Confirm that the EUT allocates new nominal transmission slots (NTS) within selection interval (SI) after 3 min to 8 min. Check that slot offset indicated in CommState matches slots used for transmission. Check that Class B “CS” are not included in the number of received stations,
- b) only free slots are used for transmission,
- c) only free slots are used for transmission.

16.6.3 Autonomous scheduled transmissions (ITDMA)

16.6.3.1 Method of measurement

Set up standard test environment and operate EUT in autonomous mode. Set NavStatus of EUT to “at anchor” giving a reporting interval of 3 min. Record transmitted scheduled position reports.

16.6.3.2 Required results

Check that EUT transmits Message 3 and allocates slots using ITDMA and that slot offset indicated in CommState matches slots used for transmission.

Check that nominal reporting interval is achieved ± 20 %.

16.6.4 Safety related/binary message transmission

16.6.4.1 Method of measurement

Set up standard test environment and operate EUT in autonomous mode as follows:

- a) Apply a 1 slot binary broadcast message (Message 8) to the PI of the EUT less than 4 s before the next scheduled transmission. Record transmitted messages. Retry with a 90 % channel load.
- b) Apply a 1 slot binary broadcast message (Message 8) to the PI of the EUT more than 4 s before the next scheduled transmission. Record transmitted messages. Retry with 90 % channel load.
- c) Apply combinations of binary broadcast message (Message 8), addressed binary message (Message 6), broadcast safety related message (Message 14) and addressed safety related message (Message 12) to the PI of the EUT. Record transmitted messages and output of the PI of the EUT.
- d) Apply more than 5 AIR sentence per minute to the PI.

16.6.4.2 Required results

Confirm that

- a) the EUT transmits this Message 8 within 4 s using ITDMA,
- b) the EUT transmits this Message 8 within 4 s using RATDMA,
- c) maximum 20 slots can be used per frame for Messages 6, 8, 12, 14, 25 and 26 and that messages using more than 3 slots are rejected. Confirm that sentence ABK is sent with acknowledge type 2 (Message could not be broadcast) when the message is rejected;
- d) the EUT transmits not more than 5 Messages 15 per minute. Confirm that sentence ABK is sent with acknowledge type 2 (Message could not be broadcast) when the message is rejected.

16.6.5 Transmission of Message 5 (ITDMA)

16.6.5.1 Method of measurement

Set up standard test environment and operate EUT in autonomous mode. Record transmitted messages.

16.6.5.2 Required results

Confirm that EUT transmits Message 5 using the ITDMA access scheme. The ITDMA access scheme shall replace a scheduled position report Message 1 with a Message 3.

16.6.6 Assigned operation

16.6.6.1 Assigned mode using reporting rates

16.6.6.1.1 Method of measurement

Operate standard test environment and EUT in autonomous mode. Transmit an assigned mode command message (Message 16) using a base station MMSI to the EUT with

- a) the number of reports per 10 min which is not a multiple of 20,
- b) the number of reports per 10 min which is higher than 600.

16.6.6.1.2 Required results

Confirm that

- a) the EUT transmits position reports Message 2 at a reporting rate that corresponds to the next highest multiple of 20 reports per 10 min,
- b) the EUT transmits position reports Message 2 at a reporting interval of 1 s.

16.6.6.2 Receiving test

16.6.6.2.1 Method of measurement

Set up standard test environment and operate EUT in autonomous mode. Transmit an assigned mode command (Message 16) using a base station MMSI to the EUT with

- slot offset and increment,
- designated reporting interval.

Record transmitted messages.

16.6.6.2.2 Required results

Confirm that EUT transmits position report Message 2 according to defined parameters and reverts to SOTDMA Message 1 with standard reporting interval after 4 min to 8 min.

16.6.6.3 Slot assignment to FATDMA reserved slots

16.6.6.3.1 Definition

A test to check the combined operation of Message 16 assignment to slots reserved by Message 20.

16.6.6.3.2 Method of measurement

Set up the standard test environment and operate EUT in autonomous mode. Transmit a data link management message (Message 20) using a base station MMSI to the EUT with slot offset and increment. Transmit an assigned mode command (Message 16) using a base station MMSI to the EUT and command it to use one or more of those FATDMA allocated slots. Record transmitted messages.

16.6.6.3.3 Required results

Confirm that the EUT uses the slots commanded by Message 16 for own transmissions.

16.6.7 Group assignment

16.6.7.1 Assignment priority

16.6.7.1.1 Method of measurement

Set up standard test environment and operate EUT in autonomous mode, and use a base station MMSI to transmit Messages 22 and 23. Transmit an assigned mode command (Message 23) to the EUT with Tx/Rx mode 1 as follows:

- a) Transmit a Message 22 defining a region with the EUT inside that region. Transmit a Message 22 to the EUT individually addressed and specifying Tx/Rx mode 2.
- b) Transmit a Message 23 to the EUT with Tx/Rx mode 1 within 10 min of test a).
- c) Repeat transmission of Message 23 to the EUT with Tx/Rx mode 1 after 15 min of test a)
- d) Repeat the test, clear the region defined by Message 22 under a). and transmit Message 22 to the EUT with regional settings specifying Tx/Rx mode 2.

NOTE This can be carried out using the method used in 17.8.1.1 b) step 2 or by assigning a new simulated position to the EUT.

Record transmitted messages.

16.6.7.1.2 Required results

Verify that:

- a) the Tx/Rx mode field setting of Message 22 takes precedence over the Tx/Rx mode field setting of Message 23;
- b) the EUT ignores the assignment by Message 23 and the setting of message takes precedence for 10 min;
- c) the EUT applies the Tx/Rx mode setting of Message 23;
- d) the Tx/Rx mode field setting of Message 23 takes precedence over the Tx/Rx mode field setting of Message 22. The receiving station shall revert to its previous Tx/Rx mode after a timeout value randomly chosen between 240 s and 480 s.

16.6.7.2 Increased reporting interval assignment

16.6.7.2.1 Method of measurement

Set up the standard test environment and operate EUT in autonomous mode with 10 s reporting interval, and use a base station MMSI to transmit Message 23 as follows:

- a) Transmit a group assignment message (Message 23) to the EUT with a reporting interval that is longer than the autonomous reporting interval.
- b) Transmit a group assignment message (Message 23) to the EUT with a quiet time command.
- c) Set the Nav status to “moored” and “at anchor” and SOG < 3 kn. Transmit a group assignment message (Message 23) to the EUT with a reporting interval that is shorter than the autonomous reporting interval.
- d) Set the Nav status to “moored” and “at anchor” and SOG > 3 kn. Transmit a group assignment message (Message 23) to the EUT with a reporting interval that is shorter than the autonomous reporting interval.

Record transmitted messages.

16.6.7.2.2 Required results

Confirm that

- a) the EUT ignores the assignment command and transmits position reports with the autonomous reporting interval,
- b) the EUT ignores the assignment command and transmits position reports with the autonomous reporting interval,
- c) the EUT ignores the assignment command and transmits position reports with the autonomous reporting interval,
- d) the EUT transmits position reports with the assigned reporting interval.

16.6.7.3 Entering interval assignment

16.6.7.3.1 Method of measurement

Set up standard test environment and operate EUT in autonomous mode with a reporting interval of 10 s. Use a base station MMSI to transmit Message 23.

- a) Transmit a group assignment command (Message 23) to the EUT with a reporting interval of 5 s assigned.
- b) Repeat test with a reporting interval of 2 s assigned.

- c) Transmit a group assignment command (Message 23) to the EUT with a reporting interval field setting 10 (next longer autonomous reporting interval).
- d) Operate EUT in autonomous mode with a reporting interval of 6 s. Transmit a group assignment command (Message 23) to the EUT with a reporting interval field setting 9 (next shorter autonomous reporting interval).

Monitor the VDL

16.6.7.3.2 Required results

Verify that:

- a) EUT enters assigned operation mode and transmits position report Message 2 with 5 s reporting interval. EUT builds up the assigned transmission scheduled according to network entry procedure; verify that unused slots of the previous reporting schedule are released.
- b) EUT enters assigned operation mode and transmits position report Message 2 with 2 s reporting interval.
- c) EUT does not enter assigned operation mode and transmits position report Message 1 with 10 s reporting interval.
- d) EUT enters assigned operation mode and transmits position report Message 2 with 2 s reporting interval.

16.6.7.4 Assignment by region

16.6.7.4.1 Method of measurement

Set up standard test environment and operate EUT in autonomous mode with a reporting interval of 10 s and use a base station MMSI to transmit Message 23 as follows:

- a) Transmit a group assignment command (Message 23) to the EUT (define station type 0 and geographic region so that the EUT is inside this region). Set the reporting rate to 2 s and apply message to VDL.
- b) Transmit a group assignment command (Message 23) to the EUT (define station type 0 and geographic region so that the EUT is outside this region). Set the reporting rate to 2 s and apply message to VDL.

16.6.7.4.2 Required results

Verify that

- a) EUT switches to assigned mode and transmits position reports with 2 s intervals. Verify that EUT reverts to normal operation mode after timeout period,
- b) EUT declines Message 23.

16.6.7.5 Assignment by station type

16.6.7.5.1 Method of measurement

Set up standard test environment and operate EUT in autonomous mode with a reporting interval of 10 s and use a base station MMSI to transmit Message 23 as follows:

- a) Transmit a group assignment command (Message 23) to the EUT (define geographic region so that the EUT is inside this region). Set the reporting interval to 2 s and the station type to 0 (all stations).
- b) Transmit a group assignment command (Message 23) to the EUT (define geographic region so that the EUT is inside this region). Set the reporting interval to 2 s and the station type to 4.

- c) Transmit a group assignment command (Message 23) to the EUT (define geographic region so that the EUT is inside this region). Set the reporting interval to 5 s and the station type to 1 (Class A Mobile). Apply this message to the VDL again within 4 min.

Record VDL and check reaction of the EUT.

16.6.7.5.2 Required results

Verify that

- a) EUT switches to assigned mode and transmits position reports with 2 s reporting interval. Verify that EUT reverts to autonomous mode after timeout period,
- b) EUT declines Message 23,
- c) EUT switches to assigned mode and transmits position reports with 5 s reporting interval. Verify that EUT reverts to autonomous operation mode after timeout period of second transmitted group assignment.

16.6.7.6 Addressing by ship and cargo type

16.6.7.6.1 Method of measurement

Set up standard test environment and operate EUT in autonomous mode with a reporting interval of 10 s and use a base station MMSI to transmit Message 23 as follows:

- a) Transmit a group assignment command (Message 23) to the EUT (define geographic region so that the EUT is inside this region). Set the reporting interval to 2 s and the ship and cargo value to a desired value. Make sure that this value is also configured in the EUT.
- b) Transmit a group assignment command (Message 23) to the EUT (define geographic region so that the EUT is inside this region). Set the reporting interval to 2 s and the ship and cargo value to a desired value. Make sure that a different value is configured in the EUT.

16.6.7.6.2 Required results

Verify that

- a) EUT switches to assigned mode and transmits position reports with 2 s reporting interval. Verify that EUT reverts to autonomous mode after timeout period,
- b) EUT declines Message 23.

16.6.7.7 Reverting from interval assignment

16.6.7.7.1 Method of measurement

Set up standard test environment and operate EUT in autonomous mode. Using a base station MMSI, transmit a group assignment command (Message 23) to the EUT with a reporting interval of 5 s assigned. Monitor the VDL until at least 1 min after timeout occurred. Repeat 10 times (transmissions of Message 23 shall not be synchronised to the initial transmission schedule of the EUT).

Measure the time T_{rev} between the reception of Message 23 and the first transmission after timeout.

16.6.7.7.2 Required results

Verify that the EUT enter autonomous mode after a time out of 4 min to 8 min and transmits position report Message 1 and releases unused slots from previous schedule.

16.6.8 Fixed allocated transmissions (FATDMA)

16.6.8.1 Method of measurement

Set up standard test environment and operate EUT in autonomous mode. Apply Message 4 to the VDL. A base station shall use a base station MMSI as follows:

- a) Transmit a data link management message (Message 20) on Channel A from a base station within 120 NM to the EUT with slot offset and increment. Record transmitted messages.
- b) Repeat the test when the EUT has no position.
- c) Repeat the test with a base station beyond 120 NM.
- d) Repeat the test without base station report (Message 4).
- e) Repeat the test with a base station within 120 NM and maintain transmissions of Message 20. Stop transmission of Message 4.

16.6.8.2 Required results

Confirm that

- a) for the base station within 120 NM, the EUT does not use slots allocated by Message 20 for own transmissions until the timeout given in the Message 20. Confirm that the EUT does not use the same slots on Channel B,
- b) the EUT does not use slots allocated by Message 20 for own transmissions until the timeout given in the Message 20,
- c) for the base station beyond 120 NM the EUT treats the slots as free,
- d) the EUT treats the slots as free,
- e) the EUT does not use slots allocated by Message 20 for own transmissions until the target timeout of the EUT occurs after Message 4 was stopped.

16.6.9 Randomisation of message transmissions

16.6.9.1 Method of measurement

Set up standard test environment. Power on the EUT and monitor the autonomous transmissions for 3 min. Restart the EUT and monitor the autonomous transmissions for another 10 min. Repeat this process for at least 10 times, starting at different seconds within a frame.

NOTE The nominal start slot (NSS) at network entry phase is randomised between the current slot and nominal increment (NI) slots forward. The first nominal slot (NS) is always the NSS.

16.6.9.2 Required results

Verify that the nominal slots are not always within the same selection interval after a power cycle by monitoring the transmissions slots. After a number of power cycles the EUT should finally start transmissions in slots that are not within the same selection interval.

16.7 Message formats

16.7.1 Received messages

16.7.1.1 Method of measurement

Set up standard test environment and operate EUT in autonomous mode. Apply messages according to Table 12 to the VDL including multiple slot messages up to 5 slots. Record messages output by the PI of EUT.

16.7.1.2 Required results

Confirm that EUT outputs corresponding message with correct field contents and format via the PI or responds as appropriate.

16.7.2 Transmitted messages

16.7.2.1 Method of measurement

Set up standard test environment and operate the EUT in autonomous mode. Initiate the transmission of messages relevant for a mobile station according to Table 12 by the EUT. Record transmitted messages.

16.7.2.2 Required results

Confirm that the EUT transmits messages with correct field content and format or responses, as appropriate. Confirm that Messages 4, 9, 16, 17, 18, 19, 20, 21, 22 and 23 are NOT being transmitted by the EUT.

17 Specific tests of network layer

(See 7.4)

17.1 Dual channel operation – Alternate transmissions

17.1.1 Method of measurement

Set up standard test environment and operate the EUT in autonomous mode on default channels AIS 1, AIS 2. Record transmitted scheduled position reports on both channels. Check CommState for slot allocation.

17.1.2 Required results

Confirm that the EUT allocates slots in alternating both channels. Repeat check for data link access period.

17.2 Regional area designation by VDL message

17.2.1 Method of measurement

Set up standard test environment and operate the EUT in autonomous mode.

- a) Using a base station MMSI, apply channel management messages (Message 22) to the VDL defining two adjacent regional areas 1 and 2 with different channel assignments for both regions and a transitional zone extending 4 NM on either side of the regional boundary. Let the EUT approach region 1 from outside region 2 more than 5 NM away from the region boundary transmitting on default channels. Record transmitted messages on all 6 channels.

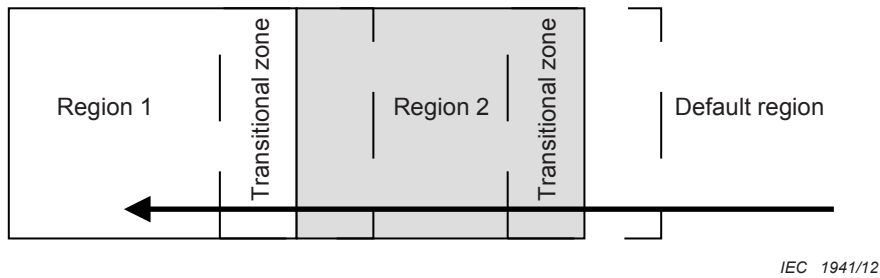

IEC 1941/12

	Primary channel	Secondary channel
Region 1	CH A 1	CH B 1
Region 2	CH A 2	CH B 2
Default region	AIS 1	AIS 2

Figure 13 – Regional area scenario

- b) Operate the unit in an area with T_x/R_x mode 1.
- c) Operate the unit in an area with T_x/R_x mode 2.
- d) Transmit Message 22 using a base station transmitting Message 4 with a position which is more than 120 NM away from the position of the EUT
- e) Transmit Message 22 using a base station which is not transmitting Message 4

17.2.2 Required results

Check that

- a) the EUT transmits and receives on the primary channels assigned for each region (see Table 24) alternating channels and doubles the number of transmissions when passing through the transitional zones. The EUT shall revert to default autonomous operation on the regional channels after leaving the transitional zones. The number of transmissions doubles on the active channel when transmitting on one channel only;
 TXT and ACA sentences are output when defining the area, crossing the boundary of the area and on request. The in-use flag shall be set to “1” if the position is inside the area which is defined by the two corner points of the area setting (e.g. the grey area defining region 2 in Figure 13);
- b) the EUT transmits on channel A only with the nominal reporting rate;
- c) the EUT transmits on channel B only with the nominal reporting rate;
- d) the EUT does not accept the channel management;
- e) the EUT does not accept the channel management.

Table 24 – Primary channels for each region

	Area	Channels in use
1	Default region	AIS 1, AIS 2
2	First transitional zone	AIS 1, CH A 2
3	Region 2	CH A 2, CH B 2
4	Second transitional zone	CH A 2, CH A 1
5	Region 1	CH A 1, CH B 1

17.3 Regional area designation by serial message

Repeat the test of 17.2 using ACA sentence for channel assignment.

17.4 Regional area designation with lost position

17.4.1 Method of measurement

Repeat the test of 17.2 using ACA sentence for channel assignment as follows:

- a) Disable position information; apply new addressed Message 22 using a base station MMSI.
- b) Make position information available again and query for area settings (ACA request).

17.4.2 Required results

Verify that

- a) the settings of the current area are still being used; check that settings of new addressed Message 22 are adopted,
- b) all area settings are still available.

17.5 Power setting

17.5.1 Method of measurement

Set up standard test environment and operate EUT in autonomous mode. Using a base station MMSI transmit channel management message (Message 22) defining output power high/low.

Repeat test using ACA sentence and manual input.

17.5.2 Required results

Check that the EUT sets output power as defined and indicates when the low power setting is in operation.

NOTE Automatic power setting for tankers is tested in 14.5.3.

17.6 Message priority handling

17.6.1 Method of measurement

Set up standard test environment and operate test equipment with 90 % channel load. Set the EUT to a reporting interval of 2 s by applying a speed of > 23 kn and a ROT of > 20°/s. Record VDL messages and check for used slots. Initiate the transmission of two 3 slot messages (Message 12 and Message 8) by the EUT. Record transmitted messages on both channels.

17.6.2 Required results

Check that the EUT transmits the messages in correct order according to their priority as given in ITU-R Recommendation M.1371-4/ A8-2.

17.7 Slot reuse and FATDMA reservations

17.7.1 Method of measurement

Set up standard test environment and operate EUT in autonomous mode. Assure that at test receiver location the signal level received from EUT exceeds the signal level received from the test transmitter as follows:

NOTE Free slots are: Slots not used, Slots used by a mobile station under way that has not been received for 3 min or more; Slots used by a base station (Message 20 and Message 4) beyond 120 NM, garbled slots.

Available slots are: Distant station slots.

Unavailable slots are: Near station slots, Slots used by a base station (Message 20 and Message 4) within 120 NM, Slots used by mobile stations reporting without position information, Slots used by mobile stations with a reporting interval of 1 min or more.

- a) Transmit test targets on channel A with 50 % channel load. Channel B is free. This test covers Rule 0 and 1.
- b) Transmit near and distant test targets with 100 % channel load on channel A in all selection intervals which are under observation. Channel B is free. There shall be enough different targets to allow the EUT to meet the requirement to reuse only one slot of each target per frame.
- c) Transmit near and distant test targets with 100 % channel load on channel B in all selection intervals which are under observation. Channel A is free.
- d) Transmit Message 4 with a position distance < 120 NM and Message 20 with slot reservations on channel A.
- e) Transmit Message 4 with a position distance > 120 NM and Message 20 with slot reservations on channel A.
- f) Transmit no Message 4 and Message 20 with slot reservations on channel A.
- g) Transmit Message 4 with a position distance < 120 NM and Message 20 with slot reservations on channel A. Transmit near and distant test targets in the unreserved slots on channel A. Channel B is free.

17.7.2 Required results

Confirm that

- a) only free slots are used for transmission on channel A, confirm that only slots which are free on channel A are used for transmissions on channel B,
- b) slots of the most distant test targets are used for transmission on channel A. Check that not more than one slot of a station is reused in a frame,
- c) for transmission on channel A that the candidate slots on channel A are organized according to the most distant station on channel B,
- d) only unreserved slots are used on channel A. Confirm that at start of Message 20 the time-out of all reserved slots is forced to 0 and the slots are changed to free slots within one frame. Confirm that for transmissions on channel B only slots which are not reserved on channel A are used after the next regular time-out 0. Confirm that after the reservation time-out all slots on channel A and B are used again,
- e) all slots are used for transmission on channels A and B,
- f) all slots are used for transmission on channels A and B,
- g) only unreserved slots are used on channel A. Confirm that slots of the most distant test targets are used for transmission. Confirm that for transmissions on channel B only slots which are not reserved on channel A are used after the next regular time-out 0.

17.8 Management of received regional operating settings

17.8.1 Test for replacement or erasure of dated or remote regional operating settings

17.8.1.1 Method of measurement

Set up the standard test environment and operate the EUT in autonomous mode. Using a base station MMSI, send a valid regional operating setting to the EUT by Message 22 with the regional operating area, including the own position of the EUT (area 1). Consecutively, send another seven valid regional operating settings to the EUT, using both Messages 22 and DSC telecommands, with regional operating areas neither overlapping with the first nor with one another. Perform the following in the order shown:

- a) Send another Message 22 to the EUT, with a ninth regional operating area (area 9) not overlapping with the previous eight regional operating areas.

- b) Send a tenth telecommand to the EUT, with a regional operating area (area 10) which partly overlaps a regional operating area.
- c) Move own position of EUT to a distance of more than 500 NM from one region defined by previous commands.
- d) Move own position of EUT to a distance of more than 500 NM from all regions defined by previous commands.
- e) Restart the EUT and make sure it cannot receive UTC. Apply a channel management area setting by message 22 and by ACA input. Wait for 24 hours.

Query for area settings (ACA request) after a), b) c and d).

17.8.1.2 Required results

Check that, after the initialization, the EUT operates according to the regional operating settings defined by area 1 and

- a) the most distant area is deleted and the other areas are available,
- b) area 10 is stored and that the old overlapped area is deleted,
- c) this area is deleted by the output of TXT and ACA sentences showing the remaining area settings,
- d) all areas are deleted by the output of a single TXT and ACA sentences showing high sea settings,
- e) all area settings have been removed.

17.8.2 Test of correct input via presentation interface or MKD

17.8.2.1 Method of measurement

Set up standard test environment and operate EUT in autonomous mode. Using a base station MMSI, perform the following tests in the following order.

- a) Send Message 22 or a DSC telecommand with valid regional operating settings to the EUT with a regional operating area, which contains the current position of own station.
- b) Input a different, valid regional operating setting (not overlapping the area defined under a) via the MKD.
- c) Send a different regional operating setting with a regional operating area which partly overlaps the regional operating area input via the MKD to the EUT via the presentation interface in the previous step, and which contains the present position of own station.
- d) Input the default operating settings via the MKD for the regional operating area, which was received by the previous command via the presentation interface.
- e) Send Message 22 or a DSC telecommand with a different regional operating setting to the EUT with a regional operating area, which contains current position of own station.
- f) Within two hours, after e), send a different regional operating setting to the EUT via the presentation interface with a valid regional operating area overlapping the regional operating area sent to the EUT by Message 22 or a DSC telecommand.

17.8.2.2 Required results

The following results are required:

- a) Confirm that the EUT uses the regional operating settings commanded by Message 22 or DSC telecommand.
- b) Step 1: Confirm that the regional operating settings of the previous Message 22 or DSC telecommand are displayed to the user on the MKD for editing.

Step 2: Check that the EUT allows the user to edit the displayed regional operating settings. Check that the EUT does not accept incomplete or invalid regional operating settings. Check that the EUT accepts a complete and valid regional operating setting.

Step 3: Check that the EUT prompts the user to confirm the intended change of regional operating settings. Check that the EUT allows the user to return to the editing menu or to abort the change of the regional operating settings.

Step 4: Check that the EUT uses the regional operating settings input via the MKD.

- c) Check that the EUT uses the regional operating settings received via the presentation interface.
- d) Check that the EUT accepts the default operating settings for the regional operating area received in c). Check that the EUT uses the default operating settings.
- e) Check that the EUT uses the regional operating settings commanded to it by Message 22 or DSC telecommand.
- f) Check that the EUT does not use the regional operating setting commanded to it via the presentation interface.

17.8.3 Test of addressed telecommand

17.8.3.1 Method of measurement

Set up a standard test environment and operate EUT in autonomous mode. Using a base station MMSI, perform the following tests in the following order:

- a) Send Message 22 or a DSC telecommand with valid regional operating settings, that are different from the default operating settings, to the EUT with a regional operating area, which contains the current position of own station.
- b) Send an addressed Message 22 or an addressed DSC telecommand to the EUT with different regional operating settings than the previous command.
- c) Move the EUT out of the regional operating area defined by the previous addressed telecommand into an area without regional operating settings.

17.8.3.2 Required results

Check that

- a) the EUT uses the regional operating settings commanded to it in a),
- b) the EUT uses the regional operating settings commanded to it in b),
- c) the EUT reverts to default.

17.8.4 Test for invalid regional operating areas

17.8.4.1 Purpose

This test simulates invalid regional operating areas (three regional operating areas with the same corner).

17.8.4.2 Method of measurement

Set up standard test environment and operate EUT in autonomous mode. Using a base station MMSI, perform the following tests in the following order after completion of all other tests related to change of regional operating settings:

- a) Send three different valid regional operating settings with adjacent regional operating areas, their corners within eight miles of each other, to the EUT by Message 22 or DSC telecommand, presentation interface input and manual input via MKD. The current own position of the EUT shall be within the regional operating area of the third regional operating setting.
- b) Move current own position of the EUT consecutively to the regional operating areas of the first two valid regional operating settings.

17.8.4.3 Required results

Check that

- a) the EUT uses the operating settings that were in use prior to receiving the third regional operating setting,
- b) the EUT consecutively uses the regional operating settings of the first two received regional operating areas.

17.9 Continuation of autonomous mode reporting interval

17.9.1 Method of test

When in the presence of an assigned mode command and in a transition zone, check that the EUT continues to report at the autonomous mode reporting interval.

17.9.2 Required results

Ensure that the autonomous reporting interval is maintained.

18 Specific tests of transport layer

(See 7.5)

18.1 Addressed messages

18.1.1 Transmission

18.1.1.1 Method of measurement

Set up standard test environment and operate EUT in autonomous mode. Set up a test target for scheduled transmissions on channel AIS 1 only. Initiate the transmission of an addressed binary message (Message 6) by the EUT (test target as destination). Record transmitted messages on both channels.

18.1.1.2 Required results

Check that the EUT transmits Message 6 on channel AIS 1. Repeat test for AIS 2.

18.1.2 Acknowledgement

18.1.2.1 Method of measurement

Operate standard test environment and EUT in autonomous mode. Apply up to 4 addressed binary messages (Message 6; EUT as destination) to the VDL on channel AIS 1. Record transmitted messages on both channels. Repeat with AIS 2.

18.1.2.2 Required results

Confirm that EUT transmits a binary acknowledge message (Message 7) with the appropriate sequence numbers within 4 s on the channel where Message 6 was received. Confirm that EUT transmit the result with an appropriate message to PI.

18.1.3 Transmission retry

18.1.3.1 Method of measurement

Set up standard test environment and operate EUT in autonomous mode. Initiate the transmission of up to 4 addressed binary messages by the EUT which will not be acknowledged (i.e. destination not available). Record transmitted messages.

18.1.3.2 Required results

Confirm that EUT retries the transmission up to 3 times (configurable) for each addressed binary message. Confirm that the time between transmissions is 4 s to 8 s. Confirm that the EUT transmits the overall result with an appropriate message to PI.

18.1.4 Acknowledgement of addressed safety related messages

Repeat test 18.1.2 with addressed safety related message.

18.1.5 Behaviour of NavStatus 14 reception

18.1.5.1 Purpose

This test verifies the correct behaviour of the received Message 1 with NavStatus 14.

18.1.5.2 Method of measurement

Set up standard test environment and operate EUT in autonomous mode as follows:

- a) Initiate the transmission of a Message 1 with NavStatus 14.
- b) Acknowledge the alarm.
- c) Initiate the transmission of a Message 1 from the same user ID with NavStatus 14 within the time out.
- d) Initiate the transmission of a Message 1 from the same user ID with NavStatus other than 14 within the time out.
- e) Initiate the transmission of a Message 1 from different user ID with NavStatus 14.

18.1.5.3 Required results

Check that

- a) the MKD indicates the received message at the top of the target list and the EUT activates the alarm relay and output an ALR sentence with alarm ID 14 via the PI,
- b) the EUT deactivates alarm relay and changes the alarm status in the ALR sentence,
- c) the EUT does not activate the alarm relay and does not change the alarm status in the ALR sentence,
- d) the EUT does not activate the alarm relay and does not output an ALR sentence with alarm ID 14,
- e) the MKD indicates the received message at the top of the target list and the EUT activates the alarm relay and output an ALR sentence with alarm ID 14 via the PI.

18.2 Interrogation responses

18.2.1 Method of measurement

Set up standard test environment and operate EUT in autonomous mode. Apply an interrogation message (Message 15; EUT as destination) to the VDL according to Table 12 for responses with Message 5 and slot offset set to 10 on channel AIS 1. Record transmitted messages on both channels.

18.2.2 Required results

Check that EUT transmits the appropriate interrogation response message as requested on channel AIS 1. Repeat test for AIS 2.

19 Specific presentation interface tests

(See 7.6)

19.1 General

The EUT including all necessary test equipment shall be set-up and checked that it is operational before testing commences.

The manufacturer shall provide sufficient technical documentation of the EUT and its interfaces in particular.

Where appropriate, tests according to various subclauses of this clause as well as other Clauses of this standard may be carried out simultaneously.

19.2 Checking manufacturer's documentation

The following checks for formal consistency and compliance shall be made for all ports:

- approved sentences against the IEC 61162-1;
- proprietary sentences against the IEC 61162-1;
- usage of fields as required for different functions including provided default values or settings;
- transmission intervals against the IEC 61162-1 and IEC 61162-2;
- configuration of hardware and software if this is relevant to the interface performance and port selection.

The following checks shall be made for compliance with the IEC 61162-1 and IEC 61162-2:

- output drive capability;
- load on the line of inputs;
- electrical isolation of input circuits.

19.3 Electrical test

19.3.1 Method of test

Input/output ports configured in accordance with IEC 61162-1 or IEC 61162-2 shall be tested according to the relevant standard with regard to minimum and maximum voltage and current at the input terminals.

19.3.2 Required results

The interfaces shall fulfil the requirements of the relevant standards.

19.4 Test of input sensor interface performance

19.4.1 Method of measurement

Connect all inputs and outputs of the EUT as specified by the manufacturer and simulate VDL-messages using the test system. Operate inputs with simulated sensor data that are both the relevant data and additional data with formatters not provided for the relevant input. Each sensor input shall be loaded with 70 % to 80 % of the interface's capacity. Record the VDL and output from the EUT's high speed port.

19.4.2 Required results

Verify that the output on the VDL and the presentation interface agree with the simulated input and that all output data is transmitted without loss or additional delay.

19.5 Test of sensor input

19.5.1 Test of GNS input

19.5.1.1 Method of measurement

Set up standard test environment and apply a GNS sentence with simulated sensor data. Record VDL output as follows:

- a) Set mode indicator to AA (Autonomous).
- b) Set mode indicator to AD, DA and DD (Differential).
- c) Set mode indicator to P (Precise)
- d) Set mode indicator to E (Estimated).
- e) Set mode indicator to M (Manual).
- f) Set mode indicator to S (Simulator).
- g) Set mode indicator to N and NN (Data not valid).
- h) Set mode indicator to A (GPS Autonomous) and time stamp field null.

Record the VDL position reports and evaluate the contents (Position, PA flag, RAIM flag and time stamp).

19.5.1.2 Required results

Confirm that

- a) all of the content is correct and PA flag = 0,
- b) all of the content is correct and PA flag = 1,
- c) all of the content is correct and PA flag = 1,
- d) external position is not used or time-stamp = 62,
- e) external position is not used or time-stamp = 61,
- f) the external position is not used,
- g) the external position is not used,
- h) all of the content is correct and PA flag = 0 and time stamp = 60.

19.5.2 Test of RMC input

19.5.2.1 Method of measurement

Set up standard test environment and apply an RMC sentence with simulated sensor data.

- a) Set status to valid and mode indicator to A (Autonomous).
- b) Set mode indicator to D (Differential).
- c) Set mode indicator to P (Precise).
- d) Set mode indicator to E (Estimated).
- e) Set Mode indicator to M (Manual).
- f) Set mode indicator to S (Simulator).
- g) Set status to invalid and mode indicator to N (Data not valid).
- h) Set mode indicator to A (Autonomous) and time stamp field null.

Record the VDL position reports and evaluate the contents (Position, PA flag, RAIM flag, time stamp, SOG and COG).

19.5.2.2 Required results

Confirm that

- a) all of the content is correct and PA flag = 0,
- b) all of the content is correct and PA flag = 1,
- c) all of the content is correct and PA flag = 1,
- d) external position and SOG/COG are not used or time-stamp = 62,
- e) external position and SOG/COG are not used or time-stamp = 61,
- f) external position and SOG/COG are not used,
- g) external position and SOG/COG are not used,
- h) all of the content is correct and PA flag = 0 and time stamp = 60.

19.5.3 Test of DTM input

19.5.3.1 Method of measurement

Set up standard test environment and apply a GNS and DTM sentence with simulated sensor data.

- a) Set local datum in the DTM sentence to “W84”, set Reference datum to other value than “W84”.
- b) Set local datum in the DTM sentence to other value than “W84”.
- c) Set local datum in the DTM sentence to “W84” again.

Repeat the test with RMC input.

Record the VDL position reports and evaluate the contents (Position, PA flag, RAIM flag and time stamp).

19.5.3.2 Required results

Confirm that

- a) the position data from the sensor input are used,
- b) the position data from the sensor input are not used,
- c) the position data from the sensor input are used.

19.5.4 Test of GBS input

19.5.4.1 Method of measurement

Set up standard test environment and apply a GNS and GBS sentence with simulated sensor data. Set the position sentence to non-differential mode.

The expected RAIM error is calculated from expected error in longitude and expected error in latitude of the GBS sentence according to Table 5 as follows:

- a) set expected RAIM error to a value ≤ 10 m;
- b) set expected RAIM error to a value > 10 m;
- c) remove the expected error in longitude and/or latitude (null field) ;
- d) set the position sentence to differential mode. Set expected RAIM error to a value ≤ 10 m;

- e) set expected RAIM error to a value > 10 m;
- f) remove the expected error in longitude and/or latitude (null field).

Repeat the test with RMC input as position sentence.

Record the VDL position reports and evaluate the contents (Position, PA flag, RAIM flag and time stamp).

19.5.4.2 Required results

Confirm that

- a) RAIM flag = 1 and PA flag = 1,
- b) RAIM flag = 1 and PA flag = 0,
- c) RAIM flag = 0 and PA flag = 0,
- d) RAIM flag = 1 and PA flag = 1,
- e) RAIM flag = 1 and PA flag = 0,
- f) RAIM flag = 0 and PA flag = 1.

19.5.5 Test of VBW input

19.5.5.1 Method of measurement

Set up standard test environment and apply a HDT and VBW sentence with simulated sensor data.

NOTE The HDT sentence is applied additionally to the VBW sentence in order to make the calculation of SOG and COG.

- a) Set status, ground speed, to valid.
- b) Set status, ground speed, to invalid.
- c) Set status, ground speed, to valid, set heading to invalid.
- d) Set status, ground speed, to valid and remove transverse ground speed.

Record the VDL position reports and evaluate the contents (SOG and COG).

19.5.5.2 Required results

Confirm that

- a) SOG and COG are correctly calculated from VBW and HDT,
- b) SOG and COG is set to default,
- c) COG is set to default,
- d) Confirm that SOG and COG is set to default.

19.5.6 Test of VTG input

19.5.6.1 Method of measurement

Set up standard test environment and apply VTG sentence with simulated sensor data.

- a) Set mode indicator to a valid value.
- b) Set mode indicator to "N" (data not valid).

Record the VDL position reports and evaluate the contents (SOG and COG).

19.5.6.2 Required results

Confirm that

- a) SOG and COG are correctly used,
- b) SOG and COG are set to default.

19.5.7 Test of HDT/THS input

19.5.7.1 Method of measurement

Set up standard test environment and apply a RMC and a HDT/THS sentence with simulated sensor data.

- a) Set valid heading data in HDT/THS.
- b) Remove heading data from HDT/THS.
- c) Set SOG > 5 kn and heading data different from COG by > 45° for 5 min.

Record the VDL position reports and evaluate the contents (heading).

19.5.7.2 Required results

Confirm that

- a) the heading value is correct,
- b) the heading value is set to default,
- c) ALR 11 is generated.

19.5.8 Test of ROT input

19.5.8.1 Method of measurement

Set up standard test environment and apply a HDT and ROT sentence with simulated sensor data. Set talker id of ROT = "TI". Set ROT status to valid ("A").

- a) Set ROT to several values between 0 and 708°/min turning left and right.
- b) Set ROT to a value of more than 708°/min turning left and right.
- c) Set ROT status to invalid ("V").

Set the ROT status to valid again and set the ROT talker ID to "HE".

When ROT values are used do as in d), e), and f):

- d) Set ROT to 9°/min turning left and right.
- e) Set ROT to 11°/min turning left.
- f) Set ROT to 11°/min turning right.

When ROT values are not used but are calculated from the HDT data do as in g), h) and i):

- g) Change the heading value in HDT with 9°/min and -9°/min.
- h) Change the heading value in HDT with 11°/min.
- i) Change the heading value in HDT with -11°/min.

Record the VDL position reports and evaluate the contents (ROT).

19.5.8.2 Required results

Confirm that

- a) the ROT value is calculated as defined in Table 6,
- b) the ROT value is –126 turning left and 126 turning right,
- c) ROT = default (-128) or 0 or ± 127 if calculated from HDT,
- d) ROT = 0,
- e) ROT = –127,
- f) ROT = 127,
- g) ROT = 0,
- h) ROT = –127,
- i) ROT = 127.

19.5.9 Test of different inputs

19.5.9.1 Method of measurement

Set up standard test environment and apply a GNS, VBW, HDT/THS and ROT sentence with simulated sensor data to the specified sensor inputs.

- a) Apply RMC, VBW, HDT and ROT to sensor input 1.
- b) Apply RMC, VBW, HDT and ROT to sensor input 2.
- c) Apply RMC, VBW, HDT and ROT to sensor input 3.
- d) Apply RMC to sensor input 1, VBW to sensor input 2, HDT and ROT to sensor input 3.

Record the VDL position reports and evaluate the contents of SOG and COG.

19.5.9.2 Required results

Confirm that

- a) all sensor data are correct,
- b) all sensor data are correct,
- c) all sensor data are correct,
- d) all sensor data are correct.

19.5.10 Test of multiple inputs

19.5.10.1 Method of measurement

Check the manufacturer's documentation for the method of handling multiple sensor inputs, for instance:

- priority of sensor ports;
- assigning sensor sentences to ports by configuration.

Set up standard test environment and apply RMC, VBW, HDT and ROT sentences with different simulated sensor data to 2 or 3 sensor inputs. Record the VDL position reports and evaluate the contents.

19.5.10.2 Required results

Confirm that for each parameter (position, SOG/COG, heading, ROT) the data from only one sentence is used, according to the manufacturer's definition.

19.6 Test of high speed output

19.6.1 Method of measurement

Set up standard test environment and simulate VDL-position reports using the test system. Record output from the EUT high speed port (see Table 16).

19.6.2 Required results

Verify that the recorded message contents agree with the simulated VDL contents (VDM sentence), its own transmitted data (VDO sentence) and its own position, SOG, COG information derived from the internal position sensor and in accordance with the sentence specifications of IEC 61162-1.

19.7 High speed output interface performance

19.7.1 Method of measurement

Set up standard test environment and operate EUT in autonomous mode. Increase the VDL load to > 90 %. Record transmitted messages and check PI output of the EUT on the port for "external display" and the "auxiliary display/pilot port".

19.7.2 Required results

Confirm that EUT outputs all received messages to the PI and the "auxiliary display/pilot port". Verify during VDL load > 90 % that the sync timing, the Tx slots and the slot number in the CommState are correct.

19.8 Output of undefined VDL messages

19.8.1 Method of measurement

Set up standard test environment and operate EUT in autonomous mode. Verify that AIS messages with undefined data contents according to Table 12 (Message type 28 or higher) are output by the PI. Repeat test for port "auxiliary display/pilot port".

19.8.2 Required results

Confirm that EUT outputs all undefined received messages to the PI.

19.9 Test of high speed input

19.9.1 Method of measurement

Set up standard test environment. Apply simulated input data, in accordance with the sentence specifications of IEC 61162-1 and Table 15 of this standard, to the EUT and record VDL output.

NOTE For the SSD sentence:

- a) the source identifier "AI" means that the A, B, C, D values are related to the internal EPFS receiver;
- b) any other source identifier means that the A, B, C, D values are related to the external EPFS.

19.9.2 Required results

Verify that the VDL message contents agree with simulated input data.

20 Long-range functionality tests

20.1 Long-range application by two-way interface

(See 8.2)

20.1.1 LR interrogation

20.1.1.1 Method of measurement

Set up standard test environment and operate EUT in autonomous mode. Apply a LR addressed interrogation message to the LR-interface port of EUT. Record LR output port and AIS high-speed output port. Set EUT to

- a) automatic response,
- b) manual response via MKD,
- c) manual response via PI.

20.1.1.2 Required results

Check that EUT displays LR interrogation messages and sends them to PI. Check that EUT outputs a LR position report message

- a) automatically (and indicates action on display),
- b) after manual confirmation via MKD,
- c) after manual confirmation via PI.

20.1.2 LR "all ships" interrogation

20.1.2.1 Method of measurement

Set up standard test environment and operate EUT in autonomous mode. Apply a LR "all ships" interrogation message to the LR-interface port of EUT defining a geographical area which contains own ship's position. Record LR output port. Set EUT to

- a) automatic response,
- b) manual response.

Repeat check with own ship outside specified area.

20.1.2.2 Required results

Check that EUT outputs a LR position report message

- a) automatically (and indicates action on display),
- b) after manual confirmation.

No response shall be output on the repeat check.

20.1.3 Consecutive LR “all ships” interrogations

20.1.3.1 Method of measurement

Set up standard test environment and operate EUT in autonomous mode. Set EUT to automatic mode. Apply 5 LR “all ships” interrogation messages to the LR-interface port of EUT defining a geographical area which contains own ship’s position.

Set the control flag in the LRI message to

- a) 0 (reply on first interrogation only),
- b) 1 (reply on all applicable interrogations).

Record LR output port.

20.1.3.2 Required results

Check that the EUT outputs a LR position report message

- a) on the first interrogation only,
- b) on all interrogations.

20.2 Long-range application by broadcast

(See 8.3)

20.2.1 Long-range broadcast

20.2.1.1 Method of measurement

Set up standard test environment, enable the EUT to transmit Message 27 and operate EUT in autonomous mode. Use base stations MMSI to transmit Message 4 and Message 23. Record the transmitted messages from the EUT. The designated long-range channels are defined in 8.3.

- a) Do not apply Message 4 and Message 23.
- b) Apply the Message 4 with the long range control bit set to 1 and 0. Place the EUT inside the RF footprint (Message 4 receiving area) of a base station.
- c) Apply the Message 4 with the long range control bit set to 1 and 0. Using the same MMSI as the Message 4, broadcast the Message 23 with station type 10 to define the base station coverage area. Place the EUT inside the RF footprint area, but outside the base station coverage area.
- d) Apply the Message 4 with the long range control bit set to 1 and 0. Using the same MMSI as the Message 4, broadcast the Message 23 with station type 10 to define the base station coverage area. Place the EUT inside the base station coverage area. Message 23 fields after station type shall not match current settings of EUT.
- e) Repeat the test d) using different MMSIs for Message 4 and Message 23.
- f) Apply the Message 4 with the long range control bit set to 0. Using the same MMSI as the Message 4, broadcast the Message 23 with station type 10 to define the base station coverage area. Place the EUT inside the base station coverage area. After 6 min, remove transmissions of Message 23.
- g) Apply the Message 4 with the long range control bit set to 0. Using the same MMSI as the Message 4, broadcast the Message 23 with station type 10 to define the base station coverage area. Place the EUT inside the base station coverage area. After 6 min, remove transmissions of Message 4.

20.2.1.2 Required results

Check that EUT transmits the appropriate messages, e.g. in addition to the normal transmission of Messages 1 and 5 with adequate reporting interval on AIS 1 and AIS2, confirm that:

- a) EUT transmits Message 27 alternating the designated long-range channels with 3 min reporting interval.
- b) Irrespective of the Message 4 long range control bit status, EUT transmits Message 27 alternating on the designated long-range channels with 3 min reporting interval.
- c) Irrespective of the Message 4 long range control bit status, EUT transmits Message 27 alternating on the designated long-range channels] with 3 min reporting interval.
- d) EUT transmits Message 27 alternating on the designated long-range channels with 3 min reporting interval when the Message 4 long-range control bit is set to 1. EUT stops transmitting Message 27 when the Message 4 long-range control bit is set to 0. Verify fields after station type in received Message 23 are ignored.
- e) Irrespective of the Message 4 long range control bit status, EUT transmits Message 27 alternating on the designated long-range channels with 3 min reporting interval.
- f) EUT begins transmission of Message 27 no sooner than 4 min and no later than 8 min after Message 23 was removed.
- g) EUT begins transmission of Message 27 beyond 3 min after Message 4 was removed.

20.2.2 Multiple assignment operation

20.2.2.1 Method of measurement

Set up standard test environment, enable the EUT to transmit Message 27 and operate EUT in autonomous mode with a reporting interval of 10 s. Use base stations MMSI to transmit Message 4 and Message 23. Record the transmitted messages from the EUT.

- a) Transmit a Group Assignment command (Message 23) to the EUT (define geographic region so that the EUT is inside this region). Set the reporting interval to 2 s and the station type to 0 (all stations).
- b) Using different MMSIs, apply the Message 4 with long range control bit set to 1 and 0 from multiple base stations partially overlapping their RF footprints. Broadcast the Message 23 from multiple base stations with station type 10 to define the base station coverage areas not overlapping. Place the EUT inside the overlapped RF footprint area.
- c) Using different MMSIs, apply the Message 4 with long range control bit set to 1 and 0 from multiple base stations partially overlapping RF footprints. Broadcast the Message 23 from multiple base stations with station type 10 to define the base station coverage areas partially overlapping the base station coverage areas. Place the EUT inside the overlapped base station coverage area.
- d) Using different MMSIs, apply the Message 4 with long range control bit set to 1 and 0 from multiple base stations partially overlapping RF footprints. Broadcast the Message 23 from one base station with station type 10 to define the base station coverage areas. Do not broadcast Message 23 from other base stations. Place the EUT inside the RF footprint area of base station not broadcasting Message 23.

20.2.2.2 Required results

Verify that

- a) EUT switches to assigned mode and transmits position reports with 2 s reporting interval. EUT reverts to autonomous mode after timeout period,
- b) Irrespective of the Message 4 long-range control bit status of both base stations, EUT transmits Message 27 alternating on the designated long-range channels with 3 min reporting interval,
- c) EUT transmits Message 27,

- d) Irrespective of the Message 4 long range control bit status of both base stations, EUT transmits Message 27 alternating on the designated long-range channels with 3 min reporting interval.

Annex A
(informative)

Block diagram of AIS

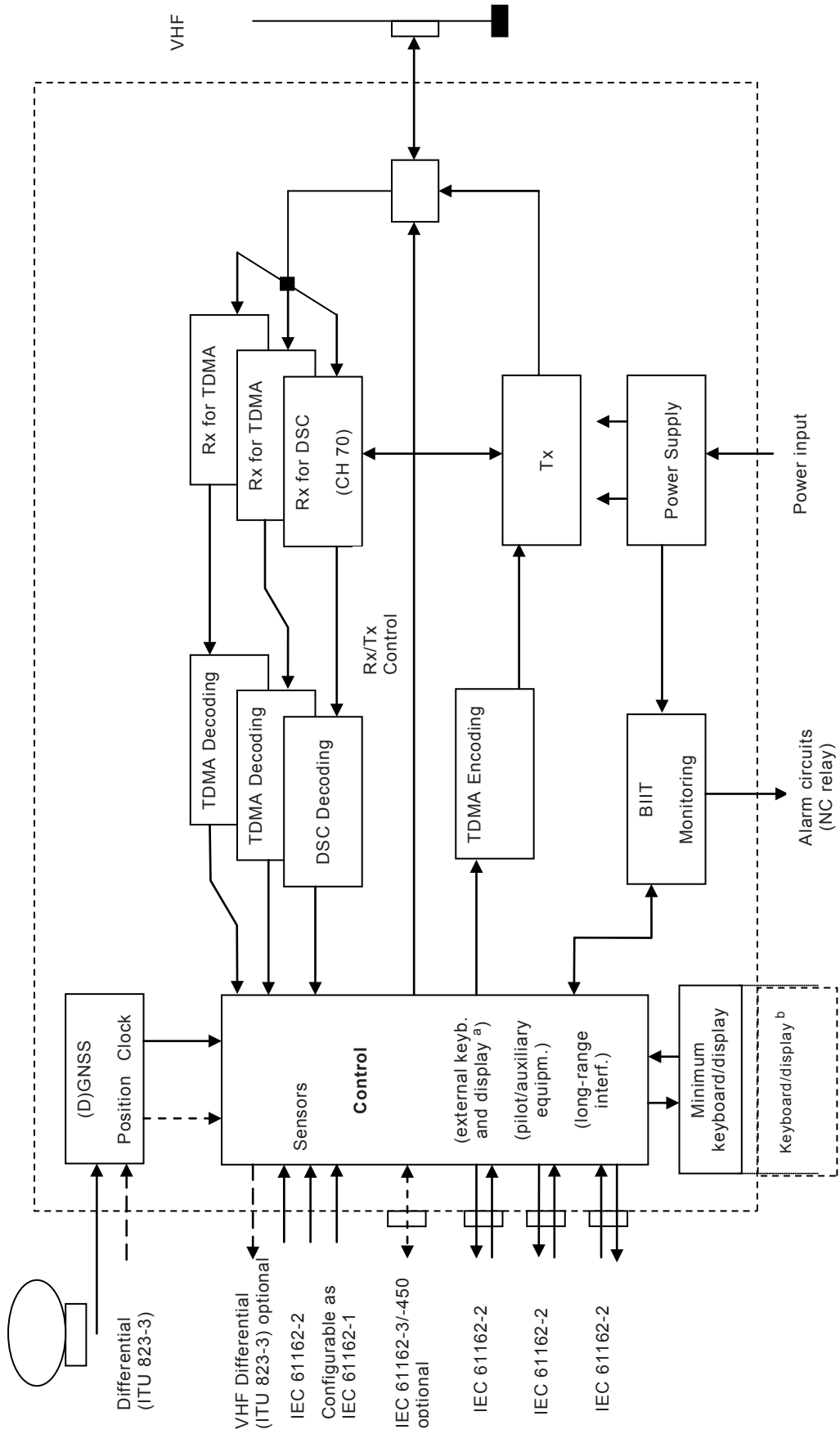

IEC 1942/12

Key
^a The external keyboard/display may be e.g. a radar, ECDIS or dedicated devices; ^b The internal keyboard/display may optionally be remote.

Annex B
(normative)

AIS interface overview (see Table 13)

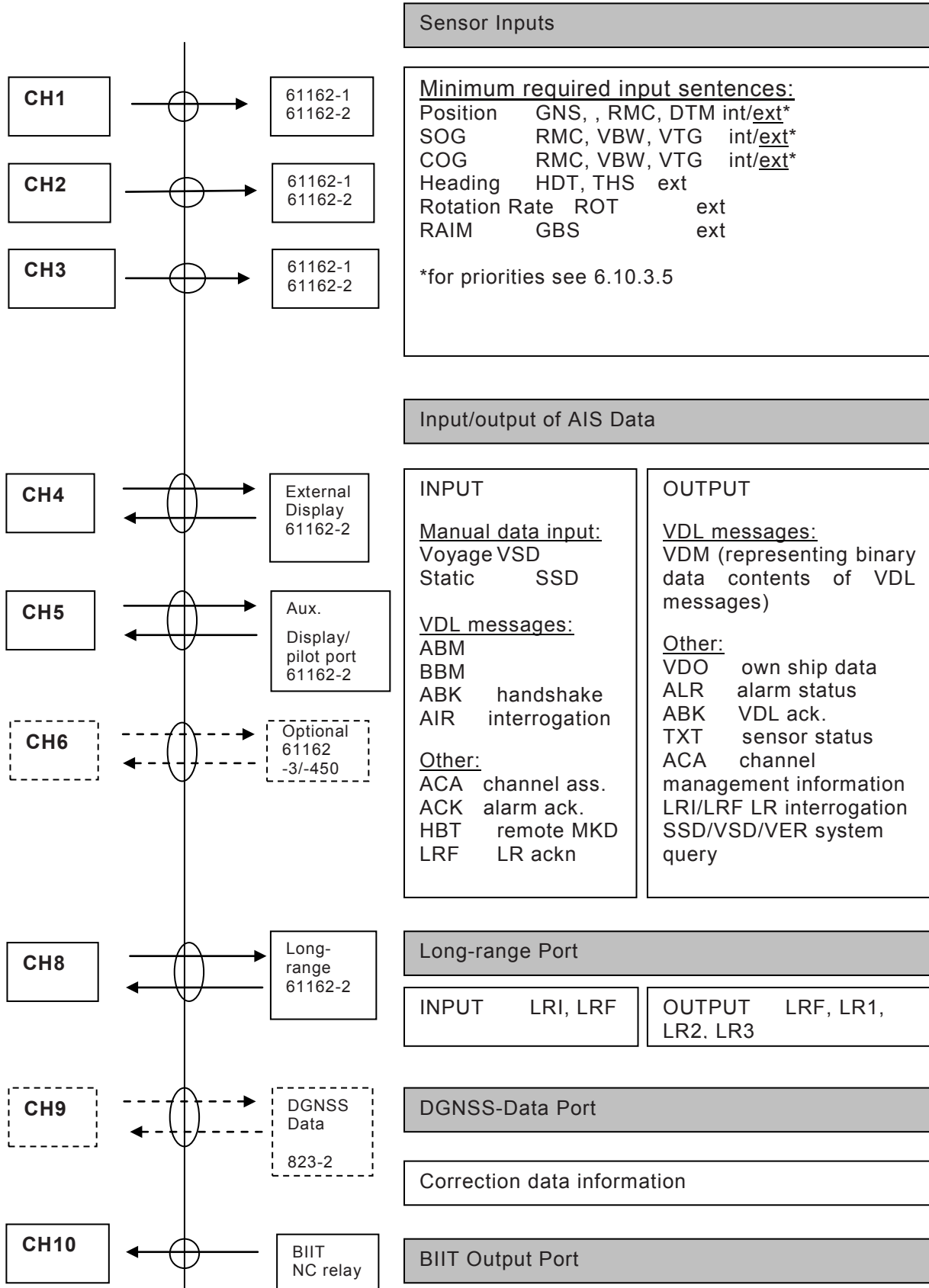

Annex C
(informative)

Block diagram of standard test environment

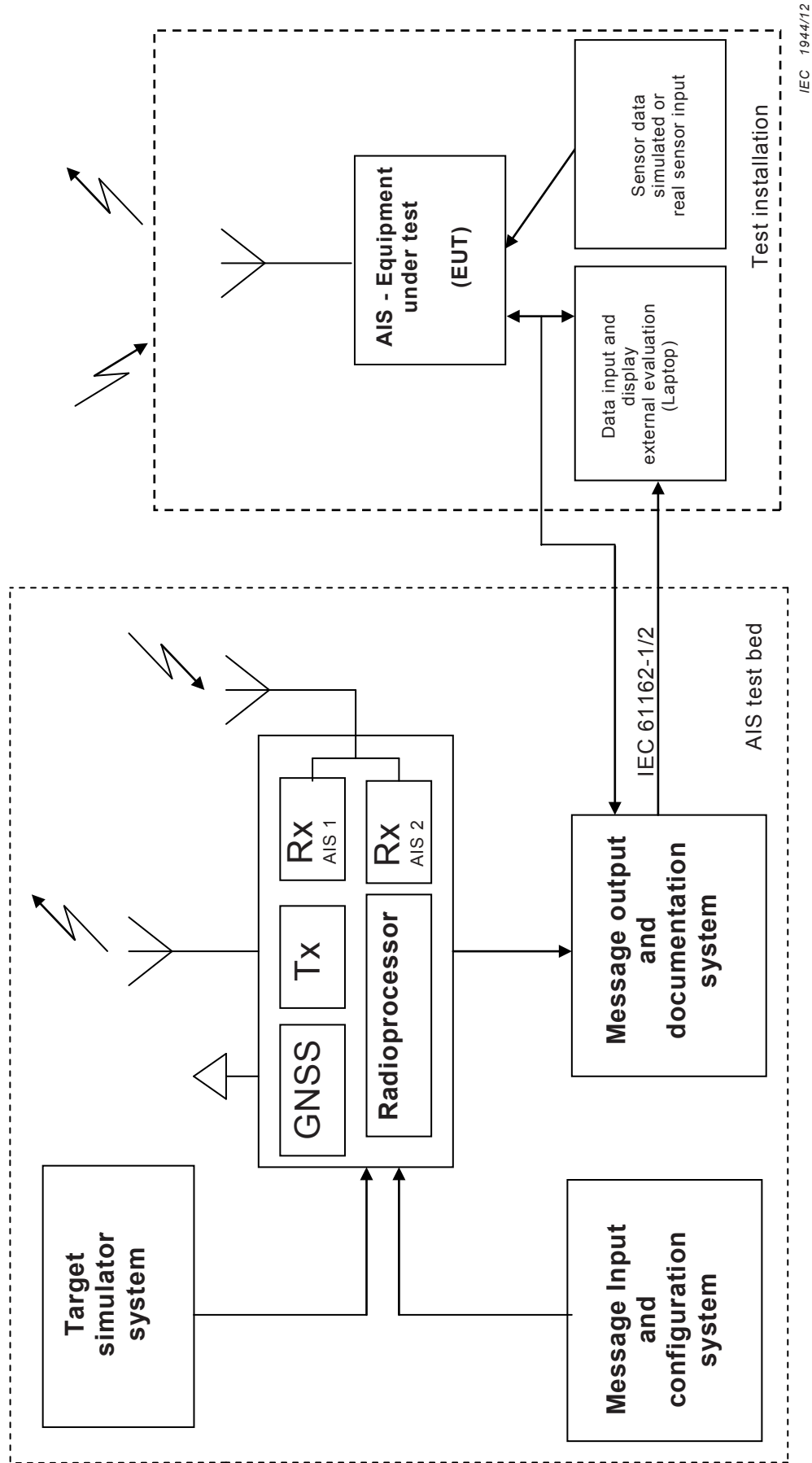

Annex D (normative)

DSC functionality

D.1 DSC compatibility

The Class A AIS shall be capable to receive and process DSC channel management telecommands conforming to the provisions of Recommendations ITU-R M.493, ITU-R M.541, ITU-R M.825 (see Recommendation ITU-R M.1371-4/A3). In order to accomplish this performance, the AIS device shall contain a dedicated DSC receiver that is tuned permanently to channel 70. However, the AIS device shall not accept the channel management command sent by stations with invalid base station MMSI as defined in 6.12.

For DSC channel management using geographical area calls, the end of sequence (EOS) character shall be EOS = 127 (no response requested). However for compatibility, Class A AIS receivers shall respond to DSC channel management commands ending in "EOS = 127" and "EOS = 117 (RQ)" even though they are not capable of transmitting DSC acknowledgements.

D.2 DSC receiver tests

NOTE For DSC receiver test signal refer to Clause 10 test signal 1.

D.2.1 Maximum sensitivity

D.2.1.1 Definition

The maximum sensitivity of the receiver is the minimum level of the signal in dBm at the nominal frequency of the receiver which, when applied to the receiver input with a test modulation, will produce a bit error rate which does not exceed 10^{-2} .

D.2.1.2 Method of measurement

The test equipment shall be set to transmit test signal 1 (continuous DSC dot pattern) as the test modulation of the RF signal generator connected to the EUT. The frequency and level of the test equipment shall be 156,525 MHz (CH70) -107 dBm under normal condition and -101 dBm under extreme condition. The EUT shall provide a logic level test output from its internal DSC demodulator to measure bit error rate (BER). The test shall be repeated at the nominal carrier frequency (156,525 MHz) $\pm 1,5$ kHz offset under normal test condition.

D.2.1.3 Required results

The BER shall not exceed 10^{-2} .

D.2.2 Error behaviour at high input levels

D.2.2.1 Definition

The dynamic range of the equipment is the range from the minimum to the maximum level of a radio frequency input signal at which the bit error rate in the output of the receiver does not exceed a specified value.

D.2.2.2 Method of measurement

A test signal, in accordance with standard test signal number 1, shall be applied to the receiver input. The level of the test signal shall be -7 dBm.

D.2.2.3 Required results

The BER shall not exceed 10^{-2} .

D.2.3 Co-channel rejection

D.2.3.1 Definition

The co-channel rejection is a measure of the capability of the receiver to receive a wanted modulated signal without exceeding a given degradation due to the presence of an unwanted modulated signal, both signals being at nominal frequency of the receiver.

D.2.3.2 Method of measurement

The wanted signal shall be standard test signal number 1. The level of the wanted signal shall be -104 dBm.

The unwanted signal shall be frequency modulated by 400 Hz with a deviation of ± 3 kHz. The input level of the unwanted signal shall be -114 dBm.

Both input signals shall be at the nominal frequency of the receiver under test and the measurement shall be repeated for displacements of the unwanted signal of up to ± 3 kHz.

D.2.3.3 Required results

The BER shall not exceed 10^{-2} .

D.2.4 Adjacent channel selectivity

D.2.4.1 Definition

The adjacent channel selectivity characterises the capability of the receiver to receive a wanted modulated signal without exceeding a given degradation due to the presence of an unwanted modulated signal that differs in frequency from the wanted signal by 25 kHz.

D.2.4.2 Method of measurement

The wanted signal shall be standard test signal number 1. The level of the wanted signal shall be -104 dBm.

The unwanted signal shall be frequency modulated by 400 Hz with a deviation of ± 3 kHz. The input level of the unwanted signal shall be -34 dBm. The unwanted signal shall be tuned to the centre frequency of the upper adjacent channels (156,550 MHz) and lower adjacent channel (156,500 MHz).

Repeat the test under extreme condition with the wanted signal level of -98 dBm and unwanted signal level of -38 dBm.

D.2.4.3 Required results

The BER shall not exceed 10^{-2} .

D.2.5 Spurious response rejection

D.2.5.1 Definition

The spurious response characterises the capability of the receiver to receive a wanted modulated signal without exceeding a given degradation due to the presence of an unwanted modulated signal with frequencies outside the band of the receiver.

D.2.5.2 Manufacturers' declarations

The manufacturers shall declare the following in order to calculate the "limited frequency range":

- list of intermediate frequencies: (IF_1, IF_2, \dots, IF_N) in Hz;
- frequency of the local oscillator at 156,525 MHz.

NOTE This may be a VCO, crystal, sampling clock, BFO, numerically controlled oscillator depending on the design of the equipment.

D.2.5.3 Introduction to the method of measurement

The measurement shall be performed over the "limited frequency range" and at the "specific frequencies of interest" (as defined below).

To determine the frequencies at which spurious responses can occur the following calculations shall be made:

- a) calculation of the "limited frequency range"

the limits of the limited frequency range (LFR) are determined from the following calculations:

$$\text{LFR} = f_{LO} \pm (IF_1 + IF_2 + \dots + IF_N)$$

- b) calculation of specific frequencies of interest (SFI) outside the limited frequency range

this is determined by the following calculations:

$$\text{SFI} = (K \times f_{LO}) \pm IF_1$$

where K is an integer from 2 to 4 and f_{LO} is the local frequency at CH70.

D.2.5.4 Method of measurement

The wanted signal shall be standard test signal number 1. The level of the wanted signal shall be -104 dBm.

The unwanted signal shall be unmodulated. The frequency shall be varied in steps of 5 kHz over the limited frequency range (LFR) and the specific frequency of interest (SFI). The level of the unwanted signal shall be -34 dBm.

D.2.5.5 Required results

At any frequency separated from the nominal frequency of the receiver by two channels or more, the BER shall not exceed 10^{-2} .

D.2.6 Intermodulation response rejection

D.2.6.1 Definition

The intermodulation response ratio characterises the capability of the receiver to receive a wanted modulated signal without exceeding a given degradation due to the presence of two or more unwanted signals with a specific frequency relationship to the wanted signal frequency.

D.2.6.2 Method of measurement

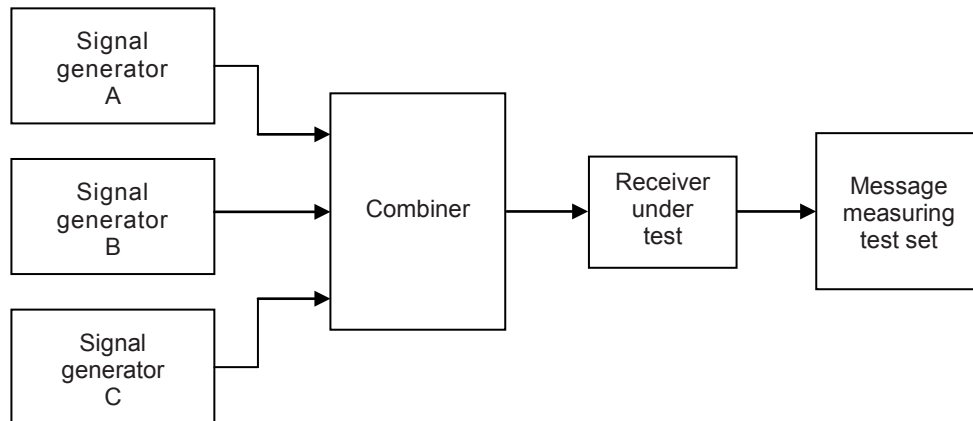

IEC 1945/12

Figure D.1 – Measurement arrangement for inter-modulation

The wanted signal represented by signal generator A (see Figure D.1) shall be at the nominal frequency of the receiver and shall be standard test signal number 1. The level of the wanted signal shall be -104 dBm.

The unwanted signal from signal generator B (see Figure D.1) shall be unmodulated and adjusted to a frequency 50 kHz above the nominal frequency of the receiver. The second unwanted signal from signal generator C (see Figure D.1) shall be modulated by 400 Hz with a deviation of ± 3 kHz and adjusted to a frequency 100 kHz above the nominal frequency of the receiver. The input level of each unwanted signal shall be -39 dBm. The test shall be repeated with the frequency of the unwanted signals below the nominal frequency of the receiver.

D.2.6.3 Required results

The BER shall not exceed 10^{-2} .

D.2.7 Blocking or desensitisation

D.2.7.1 Definition

The blocking immunity characterises the capability of the receiver to receive a wanted modulated signal without exceeding a given degradation due to the presence of an unwanted modulated signal with frequencies outside the band of the receiver.

D.2.7.2 Method of measurement

The wanted signal shall be standard test signal number 1. The level of the wanted signal shall be -104 dBm.

The unwanted signal shall be unmodulated. The frequency shall be at -10 MHz and -1 MHz and also at $+1$ MHz and $+10$ MHz relative to the nominal frequency of the wanted signal. The level of the unwanted signal shall be -20 dBm.

D.2.7.3 Required results

The BER shall not exceed 10^{-2} .

D.2.8 Conducted spurious emissions from the receiver

D.2.8.1 Definition

Conducted spurious emissions to the antenna are any RF emissions generated in the receiver and conveyed to the antenna terminal. This test shall apply only if a dedicated DSC receiver antenna connector is provided.

D.2.8.2 Method of measurement

Conducted spurious emissions shall be measured as the power level of any frequency component to the antenna terminals of the receiver. The receiver antenna terminals are connected to a spectrum analyser or selective voltmeter having an input impedance of 50 Ω and the receiver is switched on.

If the detecting device is not calibrated in terms of power input, the level of any detected components shall be determined by a substitution method using a signal generator. The measurement shall extend over the frequency range 9 kHz to 4 GHz.

D.2.8.3 Required results

The power of any spurious emission in the specified range at the antenna terminal shall not exceed -57 dBm (2 nW) in the frequency range 9 kHz to 1 GHz and -47 dBm (20 nW) in the frequency range 1 GHz to 4 GHz.

D.3 DSC functionality tests

D.3.1 Definition

The EUT shall correctly process the channel management command by DSC messages addressed to the stations in the designated geographical area or the stations individually designated.

D.3.2 Method of measurement

For the tests in this clause, set the EUT into autonomous mode using channels AIS 1 and AIS 2 with a reporting interval of 2 s. Standard AIS channel management by DSC calls consisting of format specifier 103 and message symbol number 104 with expansion symbols 09, 10, 12, 13 shall be applied to the EUT using a base station MMSI as follows:

- a) Apply a geographical channel management call using symbol constructions: "103" "geographical coordinates" "103" "source MMSI" "104" "primary CH No" "secondary CH No" "NE of CH management area" "SW of CH management area". Apply the call with EOS = 117 and EOS = 127.
- b) Move the EUT outside the channel management area.
- c) Apply an individual channel management call using symbol constructions: "120" "EUT MMSI" "103" "source MMSI" "104" "primary CH No" "secondary CH No" "NE of CH management area" "SW of CH management area". Apply the call with EOS = 117 and EOS = 127.
- d) Move the EUT outside the channel management area.
- e) Apply incorrect MMSI, position outside addressed geographic area, different course, or ship's type.
- f) Apply an extraneous call using symbol constructions: "120" "EUT MMSI" "103" "source MMSI" "104" "03" "01" "120". (Active alternative system with group number 1 and sequence number 120). Transmit a DSC telecommand using a non-base station MMSI.

D.3.3 Required results

The following items shall be verified.

- a) Verify that the EUT operates on the designated channels with the transition boundary of 5 NM.
- b) Verify that the EUT reverts to the operation on AIS 1 and AIS 2 channels.
- c) Verify that the EUT operates on the designated channels with the transition boundary of 5 NM.
- d) Verify that the EUT reverts to the operation on AIS 1 and AIS 2 channels.
- e) Verify that the EUT operation is not affected.
- f) Verify that the EUT operation is not affected.

Annex E (informative)

Optional PI port sentences

E.1 General

This annex contains sentences which may optionally be used to facilitate communication with external devices providing the functionality of a MKD. These sentences are used with the high speed data ports.

E.2 EPV – Command or report equipment property value

This sentence is a command sentence.

`$--EPV,a,c--c,c--c,x.x,c--c,*hh<CR><LF>`

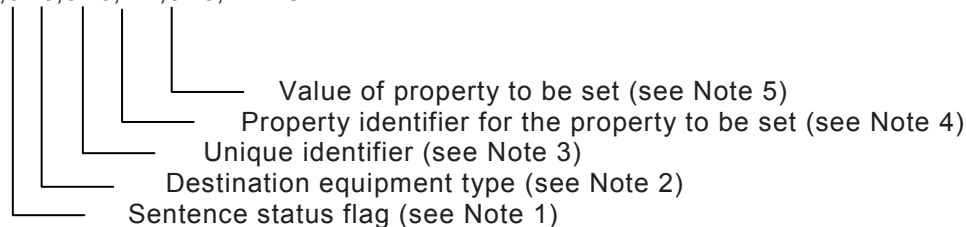

NOTE 1 Sentence status flag:

C = command

R = response

NOTE 2 The destination equipment field identifies the device type for which the sentence is targeted. The destination equipment field is the talker identifier mnemonic of the equipment for which the sentence is valid.

NOTE 3 The unique identifier identifies the same equipment irrespective of command versus response: For commands it identifies the equipment intended to receive the command. For responses it identifies the equipment that actually received the command. Under normal conditions the response will be received from the equipment for which the command was intended. Equipment should only send one or more response sentences in response to command sentences received and should not use response sentences for general reporting. For AIS Class A the unique identifier is the MMSI. The unique identifier may be null.

NOTE 4 The property identifier is a variable length integer field that identifies a parameter that can be set in accordance with Table E.1 and is intended for commissioning settings. Only the following property identifiers are permitted.

Table E.1 – Property identifier

Property identifier	Property meaning	Value range
0 to 100	Reserved	
101	Sensor 1 baud	4 800, 9 600, 14 400, 19 200, 38 400
102	Sensor 2 baud	4 800, 9 600, 14 400, 19 200, 38 400
103	Sensor 3 baud	4 800, 9 600, 14 400, 19 200, 38 400
104	Long-range baud	4 800, 9 600, 14 400, 19 200, 38 400
105	DGNSS baud	4 800, 9 600, 14 400, 19 200, 38 400
106	MMSI	000000000, 200000000 ... 799999999, 982000000 ... 987999999
107	IMO number	0000000 ... 9999999
108	Long-range interface configuration	"A" = automatic "M" = manual
109	Long-range AIS broadcast channel 1	Valid channel according ITU-R M.1084-5. See 8.3. Default value 0 indicates no transmission of message 27
110	Long-range AIS broadcast channel 2	Valid channel according ITU-R M.1084-5. See 8.3. Default value 0 indicates no transmission of message 27
111	Change administrator password	New administrator password
112	Change user password	New user password
113	AIS-SART test mode	0 = normal mode 1 = display and output AIS-SART in test mode
All other values	Reserved	

NOTE 5 The value is a variable length character string representing the configuration parameter value.

An NAK with appropriate response should be output if an EPV setting is not accepted

Example:

A practical example is an ECDIS setting the baud rate for the Port1 of an AIS transponder. The ECDIS would send the following command (MMSI of the AIS is 503123450):

```
$EIEPV,C,AI,503123450,101,38400*hh
```

The AIS would send the following response:

```
$AIEPV,R,AI,503123450,101,38400*hh
```

Another practical example is a radar setting the MMSI and IMO number of an AIS transponder and using a password. It is assumed that the MMSI is not yet set and therefore the value is 0. The radar would send the following sentences:

```
$RASPW,EPV,000000000,1,SESAME*hh
```

```
$RAEPV,C,AI,000000000,106,503123450*hh
```

```
$RASPW,EPV,503123450,1,SESAME*hh
```

```
$RAEPV,C,AI,503123450,107,9241061*hh
```

The AIS would send the following response sentences:

\$AIEPV,R,AI,503123450,106,503123450*hh

\$AIEPV,R,AI,503123450,107,9241061*hh

E.3 SPW – Security password sentence

This sentence can be used for authentication. For this purpose the sentence has to be applied before the protected sentence (for example EPV, SSD).

Other sentences may not be interleaved between the password sentence and protected sentence and the time between the SPW and the protected sentence should be limited. The password protected sentence pair should be sent without unnecessary delay between sentences. The recommendation is 1 s maximum timeout. Note that any of the signals may be lost and timed out.

If the password is not accepted (for example because it is incorrect) the command is refused using the NAK sentence.

\$--SPW,ccc,c--c,x,c--c*hh<CR><LF>

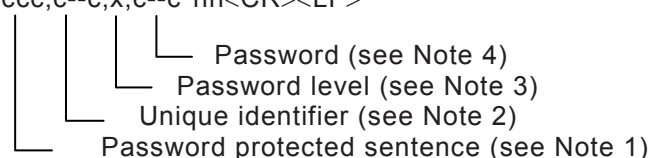

NOTE 1 The following sentence formatter that should be protected (for example EPV).

NOTE 2 For AIS the unique identifier is the MMSI.

NOTE 3 An integer number as defined below:

- 1 = User level password;
- 2 = Administrator level password;
- 3-9 = Reserved.

NOTE 4 Password as text up to 32 characters.

Example:

The password could be changed with a SPW+EPV sentence pair.

\$IISPW,EPV,211000001,2,SESAME*hh

\$IIEPV,C,AI,211000001,111,HEUREKA143*hh

With response

\$AIEPV,R,AI,211000001,111,HEUREKA143*hh

or NAK or nothing.

E.4 TRL – AIS transmitter non functioning log

This sentence is specific to AIS. It is intended to support the retrieval of the AIS non functioning log information.

This satisfies the requirement that the AIS class units log the last 10 times of more than 15 min when the unit was not transmitting position reports. This includes times when the unit was switched off and times when the transmitter was inactivated by any means.

This sentence is used to output the logged non-functioning times. On a query for this sentence up to 10 sentences will be output, one sentence for each logged non-functioning time.

This sentence is always generated as a response to a query even when no log entries exist, see Note 1.

\$--TRL,x.x,x.x,x,xxxxxxx,hhmmss.ss,xxxxxxx,hhmmss.ss,x,*hh<CR><LF>

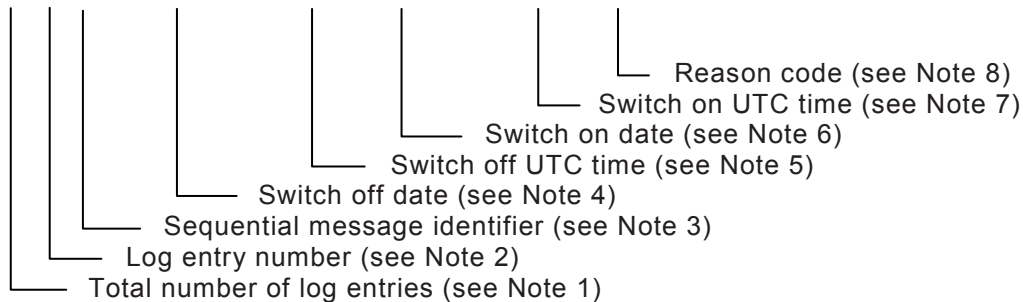

NOTE 1 Total number of log entries (1...10). When a query is received for this sentence and no log entries exist, this field should be set to "0" and all other fields should be set to NULL. When a query is received for this sentence and one or more log entries exist, this field should report the total number of log entries.

NOTE 2 Log entry number (1...Total number of log entries).

NOTE 3 The sequential message identifier provides a message identification number from 0 to 9 that is sequentially assigned and is incremented for each new multi-sentence message. The count resets to 0 after 9 is used. For a message requiring multiple sentences, each sentence of the message contains the same sequential message identification number. It is used to identify the sentences containing portions of the same message. This allows for the possibility that other sentences might be interleaved with the message sentences that, taken collectively, contain a single message.

NOTE 4 Switch off date, in the format "ddmmyyyy".

NOTE 5 Switch off UTC time. Required resolution is in minutes. The seconds may be set to 0 and the fractional part may be omitted.

NOTE 6 Switch on date, in the format "ddmmyyyy".

NOTE 7 Switch on UTC time. Required resolution is in minutes. The seconds may be set to 0 and the fractional part may be omitted.

NOTE 8 Reason for Tx non-functioning:

- 1 = power off;
- 2 = silent mode;
- 3 = transmission switched off by channel management command;
- 4 = equipment malfunction;
- 5 = invalid configuration.

Annex F
(informative)
Alarm handling

	Alarm popup window (recommended)	Alarm indication on the screen (6.11.3)	Alarm relay (6.10.2.3)	Alarm list (accessible for the user) (6.10) (6.11.3)	Tx ALR sentence on PI (6.10.2)
1 Alarm active	on occurrence	1	1	Add new alarm entry	Tx ALR sentence with status „A“ upon occurrence and repeat every 30 s
2 Alarm active and acknowledged	Off after acknowledgement	1	0	Update corresponding alarm entry as „ack'ed“	Update corresponding ALR sentence after ack and repeat every 30 s
3 Alarm condition cleared (not exceeded) a) from status 1 b) from status 2	Off after clearance	0	0	Delete corresponding alarm from list	Update corresponding sentence (status „V“) Once (one updated output) Go to 4
4 No alarms pending	0	0	0	List empty	Empty ALR sentence every 60 s

Annex G (normative)

Calculation of area size and distance

G.1 Importance of a common method for area size and distance calculations

An AIS unit will need to calculate distances with regard to many aspects. Many of these distances are paramount to how the AIS unit should operate in certain situations. This includes (but is not limited to) calculating distance between own vessel and other vessels within radio range, channel management areas (sizes and distance from its boundaries) and interrogation areas. This annex specifies the methods allowed to use with regard to the different distance and size calculations.

G.2 Calculation of area sizes

To calculate the size of the areas given in Message 22 and Message 23, along with the channel management message sent by DSC, the following method shall be used.

Coordinates of NE and SW points of the area are given in Table G.1.

Table G.1 – Coordinate points

Corner	Latitude	Longitude
NE	a deg, b min	c deg, d min
SW	e deg, f min	g deg, h min

The length around equator is defined in Equation (G.1).

The length of the NE-NW side (L_{NE-NW}) is defined in Equation (G.2).

The length of the SE-SW side (L_{SE-SW}) is defined in Equation (G.3).

The length of the polar circumference is defined in Equation (G.4).

The length of the NE-SE (L_{NE-SE}) and NW-SW (L_{NW-SW}) is defined in Equation (G.5).

$$\text{Equation (G.1)} \quad L_E = 40\,075,017 \text{ (km)} / 1,852 \text{ (km/NM)} = 21\,638,778 \text{ (NM)}$$

$$\text{Equation (G.2)} \quad L_{NE-NW} = ((c+d/60) - (g+h/60)) \times (L_E \times \cos(a+b/60)) / 360 \text{ (NM)}$$

$$\text{Equation (G.3)} \quad L_{SE-SW} = ((c+d/60) - (g+h/60)) \times (L_E \times \cos(e+f/60)) / 360 \text{ (NM)}$$

$$\text{Equation (G.4)} \quad L_P = 40\,007,863 \text{ (km)} / 1,852 \text{ (km/NM)} = 21\,602,518 \text{ (NM)}$$

$$\text{Equation (G.5)} \quad L_{NE-SE} = L_{NW-SW} = ((a+b/60) - (e+f/60)) \times L_P / 360 \text{ (NM)}$$

To achieve the required accuracy in these calculations the calculation resolution needs to have at least 3 fractional digits (i.e. 16 bits floating point).

G.3 Calculation of general distances

G.3.1 General

Two methods are acceptable for distance calculations. These are Great-circle calculation and Rhumb-Line (Loxodrome) calculation.

G.3.2 Great-circle

Great-circle (big-circle) distance is the shortest distance between two points on the surface of a sphere, measuring along the surface of the sphere. A floating point resolution of 32 bits is recommended.

The Haversine formula for calculating great-circle distance is given in Equation 5 where d is the great-circle distance between the positions $lat1$, $lon1$ and $lat2$, $lon2$ and r is the mean Earth's radius which is 6 371,009 km (3 440 069,65 NM).

Equation (G.5)

$$d = 2r \operatorname{asin} \left(\sqrt{\sin^2 \left(\frac{lat2 - lat1}{2} \right) + \cos(lat1) \cos(lat2) \sin^2 \left(\frac{lon2 - lon1}{2} \right)} \right)$$

Equation (G.5) is computationally intensive. A quicker way of doing great-circle distance calculations would be to use the law of cosines for spherical trigonometry given in Equation (G.6).

Equation (G.6)

$$d = r \operatorname{acos}(\sin(lat1)\sin(lat2) + \cos(lat1)\cos(lat2)\cos(lon2 - lon1))$$

Although mathematically sane, the arcus cosine function is not sufficiently accurate on most computer systems and leads to inaccuracies when the distances are short, henceforth a lookup table for arcus cosine should be used with 32 bits floating point resolution to maintain accuracy.

G.3.3 Rhumb-line distance

A rhumb-line (loxodrome) is a line that crosses all the meridians of longitude at the same angle. This gives the benefit of having a fixed course for the entire distance calculated. Rhumb-line calculation can be used directly in Mercator maps. The stretched latitude difference is given in Equation (G.7), and the rhumb-line distance in Equation (G.8).

Equation (G.7)

$$\Delta\varphi = \ln \left(\frac{\tan \left(\frac{lat2}{2} + \frac{\pi}{4} \right)}{\tan \left(\frac{lat1}{2} + \frac{\pi}{4} \right)} \right)$$

Equation (G.8)

$$d = r \sqrt{(\Delta lat)^2 + \left(\frac{\Delta lat}{\Delta\varphi} \right)^2 \Delta lon^2}$$

The rhumb-line method is not as precise as big-circle method at the same calculation resolution. However, for all distances critical to the mobile unit, the difference is negligible.

Annex H (normative)

Transmission of binary Messages 25 and 26

NOTE Reference to IEC 61162-1 gives a possible later version of these sentences.

H.1 General

This annex contains ABM, BBM and ABK sentences that have been modified to enable transmission of messages 25 and 26.

H.2 ABM – AIS Addressed Binary and Safety Related Message

This sentence supports ITU-R M.1371 Messages 6, 12, 25 and 26 and provides an external application with a means to exchange data via an AIS transponder. Data is defined by the application only, not the AIS unit. This sentence offers great flexibility for implementing system functions that use the transponder like a communications device. After receiving this sentence via the IEC 61162-2 interface, the transponder initiates a VDL broadcast of Message 6, 12, 25, or 26. The AIS unit will make up to four broadcasts of Messages 6 and 12. The actual number will depend on the reception of an acknowledgement from the addressed "destination" AIS unit. The success or failure of reception of this transmission by the addressed AIS unit for Messages 6 and 12 is confirmed through the use of the "Addressed binary and safety related message acknowledgement" ABK sentence formatter, and the processes that supports the generation of an ABK sentence. The AIS transponder determines the appropriate communications state for transmission of Message 26 over the VHF data Link.

!--ABM,x,x,x,xxxxxxxx,x,xx,s--s,x*hh<CR><LF>

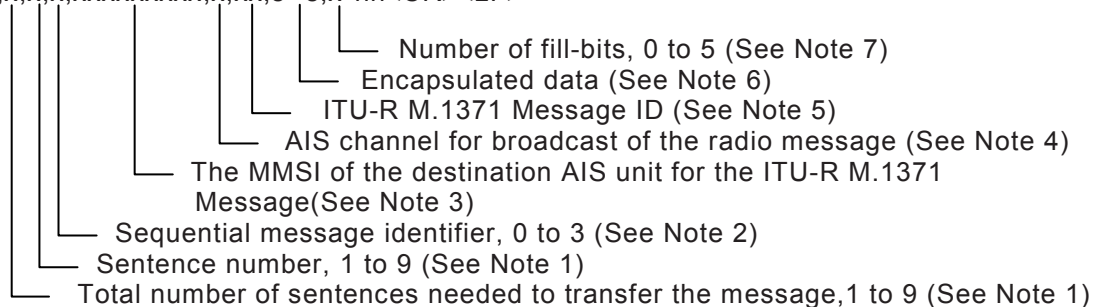

NOTE 1 The total number of sentences required to transfer the binary message data to the AIS unit.

The first field specifies the total number of sentences used for a message, minimum value 1.

The second field identifies the order of this sentence in the message, minimum value 1.

All sentences contain the same number of fields. Successive sentences may use null fields for fields that have not changed, such as fields 4, 5, and 6.

NOTE 2 This sequential message identifier serves two purposes. It meets the requirements as stated in the IEC 61162-1 "Sequential message identifier field" description and it is the sequence number utilized by ITU-R M.1371 in Message types 6 and 12. The range of this field is restricted by ITU-R M1371 to 0 – 3. The sequential message identifier value may be reused after the AIS unit provides the "ABK" acknowledgement for this number.

NOTE 3 The MMSI of the AIS unit that is the destination of the message.

NOTE 4 The AIS channel used for the broadcast:

- 0 = no broadcast channel preference;
- 1 = Broadcast on AIS channel A;
- 2 = Broadcast on AIS channel B;
- 3 = Broadcast message on both AIS channels, A and B.

NOTE 5 The ITU-R M.1371 message Id for the following addressed Messages:

- 6 = Binary addressed message;
- 12 = Addressed safety related message;
- 25 = Single slot binary message 25 (binary data coded using the 16-bit Application identifier) ;
- 70 = Single slot binary message 25 (unstructured binary data) ;
- 26 = Multiple slot binary message 26 with Communications State (binary data coded using the 16-bit Application identifier);
- 71 = Multiple slot binary message 26 with Communications State (unstructured binary data).

NOTE 6 This is the content of the "binary data" parameter for ITU-R M.1371 Message 6, or the "Safety related Text" parameter for Message 12, or the "binary data" parameter for Message 25, or the "binary data" parameter for Message 26. The first sentence may contain up to 48 valid Six Bit codes (288 bits). Following sentences may contain up to 60 valid Six Bit codes (360 bits), if fields 4, 5, and 6 are unchanged from the first sentence and set to null. The actual number of valid characters shall be such that the total number of characters in a sentence does not exceed the "82-character" limit.

NOTE 7 This cannot be a null field. See IEC 61162-1 "Fill Bits field" description.

H.3 BBM – AIS Broadcast Binary Message

This sentence supports generation of ITU-R M.1371 binary Messages 8, 14, 25, and 26. This provides the application with a means to broadcast data, as defined by the application only. Data is defined by the application only – not the AIS. This sentence offers great flexibility for implementing system functions that use the transponder like a digital broadcast device. After receiving this sentence via the IEC 61162-2 interface, the AIS unit initiates a VHF broadcast of Message 8, 14, 25, or 26 within 4 s. See the ABK sentence for acknowledgement of the BBM with Messages 8 and 14. The AIS transponder determines the appropriate communications state for transmission of Message 26 over the VHF data link.

!--BBM,x,x,x,x,xx,s--s,x*hh<CR><LF>

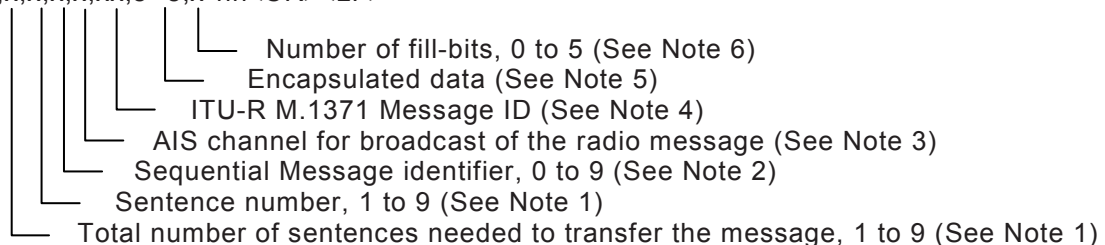

NOTE 1 The total number of IEC 61162-1 sentences required to transfer the contents of the binary message to the AIS unit. The first field specifies the total number of sentences used for a message, minimum value 1. The second field identifies the order of this sentence in the message, minimum value 1. All sentences contain the same number of fields. Successive sentences may use null fields for fields that have not changed, such as fields 4 and 5.

NOTE 2 The Sequential message identifier provides a message identification number from 0 to 9 that is sequentially assigned and is incremented for each new multi-sentence message. The count resets to 0 after 9 is used. For a message requiring multiple sentences, each sentence of the message contains the same sequential message identification number. It is used to identify the sentences containing portions of the same message. This allows for the possibility that other sentences might be interleaved with the message sentences that, taken collectively, contain a single message. This value is used by the ABK sentence to acknowledge a specific BBM sentence.

NOTE 3 The AIS channel that shall be used for the broadcast:

- 0 = no broadcast channel preference;
- 1 = Broadcast on AIS channel A;
- 2 = Broadcast on AIS channel B;
- 3 = Broadcast the message on both AIS channels A and B.

NOTE 4 The ITU-R M.1371 Message ID for the following broadcast messages:

- 8 = Binary broadcast message;
- 14 = Safety related broadcast message;
- 25 = Single slot binary message 25 (binary data coded using the 16-bit Application identifier);

- 70 = Single slot binary message 25 (unstructured binary data) ;
- 26 = Multiple slot binary message 26 with Communications State (binary data coded using the 16-bit Application identifier) ;
- 71 = Multiple slot binary message 26 with Communications State (unstructured binary data).

NOTE 5 This is the content of the "binary data" parameter for ITU-R M.1371 Messages 8, 25 or 26, or the "Safety related Text" parameter for Message 14. The first sentence may contain up to 58 valid Six Bit codes (348 bits). Following sentences may contain up to 60 valid Six Bit codes (360 bits), if fields 4 and 5 are unchanged from the first sentence and set to null. The actual number of characters shall be such that the total number of characters in a sentence does not exceed the "82-character" limit.

NOTE 6 This cannot be a null field. See IEC 61162-1 "Fill Bits field" description.

H.4 ABK – AIS Addressed and binary broadcast acknowledgement

The ABK-sentence is generated when a transaction, initiated by reception of an ABM, AIR, or BBM sentence, is completed or terminated. This sentence provides information about the success or failure of a requested ABM broadcast of either ITU-R M.1371 Messages 6 or 12. The ABK process utilises the information received in ITU-R M.1371 Messages 7 and 13. Upon reception of either a VHF Data-link Message 7 or 13, or the failure of Messages 6 or 12, the AIS unit delivers the ABK sentence to the external application. This sentence is also used to report to the external application the AIS unit's handling of the AIR (ITU-R M.1371 Message 15) and BBM (ITU-R M.1371 Messages 8, 14, 25 and 26) sentences. The external application initiates an interrogation through the use of the AIR-sentence, or a broadcast through the use of the BBM sentence. The AIS unit generates an ABK sentence to report the outcome of the ABM, AIR, or BBM broadcast process.

\$--ABK,xxxxxxxx,x,x,x,x*hh<CR><LF>

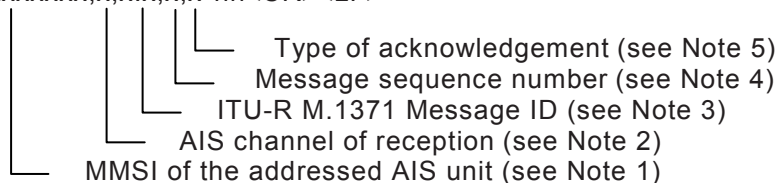

NOTE 1 Identifies the distant addressed AIS unit involved with the acknowledgement. If more than one MMSI is being addressed (ITU-R M.1371 Messages 15 and 16), the MMSI of the first distant AIS unit, identified in the message, is the MMSI reported here. This is a null field when the ITU-R M.1371 Message type is 8 or 14.

NOTE 2 Indication of the VHF data link channel upon which a Message type 7 or 13 acknowledgement was received. An "A" indicates reception on channel A. A "B" indicates reception on channel B.

NOTE 3 This indicates to the external application the type of ITU-R M.1371 message that this ABK sentence is addressing. Also see the message IDs listed in Note 4.

NOTE 4 The message sequence number, together with the Message ID and MMSI of the addressed AIS unit, uniquely identifies a previously received ABM, AIR, or BBM sentence. Generation of an ABK sentence makes a sequence message identifier available for re-use. The message ID determines the source of the message sequence number. The following lists the source by message ID:

ITU-R M.1371 Message ID Message sequence number source:

- 6 sequential message identifier from ABM sentence;
- 7 addressed AIS unit's Message 7 sequence number;
- 8 sequential message identifier from BBM sentence;
- 12 sequential message identifier from ABM sentence;
- 13 addressed AIS unit's Message 13 sequence number;
- 14 sequential message identifier from BBM sentence;
- 15 no source, the message sequence number should be null;
- 25 sequential message identifier from ABM or BBM sentence (structured binary data);
- 26 sequential message identifier from ABM or BBM sentence (structured binary data);
- 70 sequential message identifier from ABM or BBM sentence (unstructured binary data);
- 71 sequential message identifier from ABM or BBM sentence (unstructured binary data).

NOTE 5 Acknowledgements provided:

- 0 = Message (6 or 12) successfully received by the addressed AIS unit;
- 1 = Message (6 or 12) was broadcast, but no acknowledgement by the addressed AIS unit;
- 2 = message could not be broadcast (i.e. quantity of encapsulated data exceeds five slots);
- 3 = requested broadcast of Message (8, 14, 15, 25 or 26) has been successfully completed;
- 4 = late reception of a Message 7 or 13 acknowledgement that was addressed to this AIS unit (own ship) and referenced as a valid transaction.

Bibliography

IEC 61097-14, *Global maritime distress and safety system (GMDSS) – Part 14: AIS search and rescue transmitter (AIS–SART) – Operational and performance requirements, methods of testing and required test results*

IEC 61108-1, *Maritime navigation and radiocommunication equipment and systems – Global navigation satellite systems (GNSS) – Part 1: Global positioning system (GPS) – Receiver equipment – Performance standards, methods of testing and required test results*

IEC 61108-2, *Maritime navigation and radiocommunication equipment and systems – Global navigation satellite systems (GNSS) – Part 2: Global navigation satellite system (GLONASS) – Receiver equipment – Performance standards, methods of testing and required test results*

IEC 61162-3, *Maritime navigation and radiocommunication equipment and systems – Digital interfaces – Part 3: Serial data instrument network*

IEC 61162-450, *Maritime navigation and radiocommunication equipment and systems – Digital interfaces – Part 450: Multiple talkers and listeners – Ethernet interconnection*

IEC 62287-1, *Maritime navigation and radiocommunication equipment and systems – Class B shipborne equipment of the automatic identification system (AIS) – Part 1: Carrier-sense time division multiple access (CSTDMA) techniques*

IEC 62320-1, *Maritime navigation and radiocommunication equipment and systems – Automatic identification system (AIS) – Part 1: AIS Base Stations – Minimum operational and performance requirements, methods of test and required test results*

IEC 62320-2, *Maritime navigation and radiocommunication equipment and systems – Automatic identification system (AIS) – Part 2: AIS AtoN Stations – Operational and performance requirements, methods of test and required test results*

ISO 9000 (all parts), *Quality management systems – Fundamentals and vocabulary*

IMO COMSAR.1/Circ.46, *AIS safety-related messaging*

IMO Resolution A.526(13), *Performance standards for rate-of-turn indicators*

IMO Resolution A.851(20), *General principles for ship reporting systems and ship reporting requirements, including guidelines for reporting incidents involving dangerous goods, harmful substances and/or marine pollutants*

ITU, *Radio Regulations*

ITU-R Recommendation M.823, *Technical characteristics of differential transmissions for global navigation satellite systems from maritime radio beacons in the frequency band 283.5-315 kHz in Region 1 and 285-325 kHz in Regions 2 and 3*

ITU-R Recommendation M.585, *Assignment and use of maritime mobile service identities*

ITU-R Recommendation M.1084, *Interim solutions for improved efficiency in the use of the band 156-174 MHz by stations in the maritime mobile service*

British Standards Institution (BSI)

BSI is the national body responsible for preparing British Standards and other standards-related publications, information and services.

BSI is incorporated by Royal Charter. British Standards and other standardization products are published by BSI Standards Limited.

About us

We bring together business, industry, government, consumers, innovators and others to shape their combined experience and expertise into standards-based solutions.

The knowledge embodied in our standards has been carefully assembled in a dependable format and refined through our open consultation process. Organizations of all sizes and across all sectors choose standards to help them achieve their goals.

Information on standards

We can provide you with the knowledge that your organization needs to succeed. Find out more about British Standards by visiting our website at bsigroup.com/standards or contacting our Customer Services team or Knowledge Centre.

Buying standards

You can buy and download PDF versions of BSI publications, including British and adopted European and international standards, through our website at bsigroup.com/shop, where hard copies can also be purchased.

If you need international and foreign standards from other Standards Development Organizations, hard copies can be ordered from our Customer Services team.

Subscriptions

Our range of subscription services are designed to make using standards easier for you. For further information on our subscription products go to bsigroup.com/subscriptions.

With **British Standards Online (BSOL)** you'll have instant access to over 55,000 British and adopted European and international standards from your desktop. It's available 24/7 and is refreshed daily so you'll always be up to date.

You can keep in touch with standards developments and receive substantial discounts on the purchase price of standards, both in single copy and subscription format, by becoming a **BSI Subscribing Member**.

PLUS is an updating service exclusive to BSI Subscribing Members. You will automatically receive the latest hard copy of your standards when they're revised or replaced.

To find out more about becoming a BSI Subscribing Member and the benefits of membership, please visit bsigroup.com/shop.

With a **Multi-User Network Licence (MUNL)** you are able to host standards publications on your intranet. Licences can cover as few or as many users as you wish. With updates supplied as soon as they're available, you can be sure your documentation is current. For further information, email bsmusales@bsigroup.com.

BSI Group Headquarters

389 Chiswick High Road London W4 4AL UK

Revisions

Our British Standards and other publications are updated by amendment or revision.

We continually improve the quality of our products and services to benefit your business. If you find an inaccuracy or ambiguity within a British Standard or other BSI publication please inform the Knowledge Centre.

Copyright

All the data, software and documentation set out in all British Standards and other BSI publications are the property of and copyrighted by BSI, or some person or entity that owns copyright in the information used (such as the international standardization bodies) and has formally licensed such information to BSI for commercial publication and use. Except as permitted under the Copyright, Designs and Patents Act 1988 no extract may be reproduced, stored in a retrieval system or transmitted in any form or by any means – electronic, photocopying, recording or otherwise – without prior written permission from BSI. Details and advice can be obtained from the Copyright & Licensing Department.

Useful Contacts:

Customer Services

Tel: +44 845 086 9001

Email (orders): orders@bsigroup.com

Email (enquiries): cservices@bsigroup.com

Subscriptions

Tel: +44 845 086 9001

Email: subscriptions@bsigroup.com

Knowledge Centre

Tel: +44 20 8996 7004

Email: knowledgecentre@bsigroup.com

Copyright & Licensing

Tel: +44 20 8996 7070

Email: copyright@bsigroup.com



...making excellence a habit.™