

BS EN 61978-1:2014



BSI Standards Publication

# Fibre optic interconnecting devices and passive components — Fibre optic passive chromatic dispersion compensators

Part 1: Generic specification

**bsi.**

...making excellence a habit.™

### **National foreword**

This British Standard is the UK implementation of EN 61978-1:2014. It is identical to IEC 61978-1:2014. It supersedes BS EN 61978-1:2010 which is withdrawn.

The UK participation in its preparation was entrusted by Technical Committee GEL/86, Fibre optics, to Subcommittee GEL/86/2, Fibre optic interconnecting devices and passive components.

A list of organizations represented on this committee can be obtained on request to its secretary.

This publication does not purport to include all the necessary provisions of a contract. Users are responsible for its correct application.

© The British Standards Institution 2014.

Published by BSI Standards Limited 2014

ISBN 978 0 580 82164 6

ICS 33.180.01

### **Compliance with a British Standard cannot confer immunity from legal obligations.**

This British Standard was published under the authority of the Standards Policy and Strategy Committee on 30 September 2014.

### **Amendments/corrigenda issued since publication**

<b>Date</b>	<b>Text affected</b>
-------------	----------------------

---

EUROPEAN STANDARD

**EN 61978-1**

NORME EUROPÉENNE

EUROPÄISCHE NORM

August 2014

ICS 33.180.01

Supersedes EN 61978-1:2010

English Version

**Fibre optic interconnecting devices and passive components -  
Fibre optic passive chromatic dispersion compensators - Part 1:  
Generic specification  
(IEC 61978-1:2014)**

Dispositifs d'interconnexion et composants passifs à fibres optiques - Compensateurs de dispersion chromatique passifs à fibres optiques - Partie 1: Spécification générique (CEI 61978-1:2014)

Lichtwellenleiter - Verbindungselemente und passive Bauteile - Passive Lichtwellenleiter - Kompensatoren mit chromatischer Dispersion - Teil 1: Fachgrundspezifikation (IEC 61978-1:2014)

This European Standard was approved by CENELEC on 2014-06-27. CENELEC members are bound to comply with the CEN/CENELEC Internal Regulations which stipulate the conditions for giving this European Standard the status of a national standard without any alteration.

Up-to-date lists and bibliographical references concerning such national standards may be obtained on application to the CEN-CENELEC Management Centre or to any CENELEC member.

This European Standard exists in three official versions (English, French, German). A version in any other language made by translation under the responsibility of a CENELEC member into its own language and notified to the CEN-CENELEC Management Centre has the same status as the official versions.

CENELEC members are the national electrotechnical committees of Austria, Belgium, Bulgaria, Croatia, Cyprus, the Czech Republic, Denmark, Estonia, Finland, Former Yugoslav Republic of Macedonia, France, Germany, Greece, Hungary, Iceland, Ireland, Italy, Latvia, Lithuania, Luxembourg, Malta, the Netherlands, Norway, Poland, Portugal, Romania, Slovakia, Slovenia, Spain, Sweden, Switzerland, Turkey and the United Kingdom.



European Committee for Electrotechnical Standardization  
Comité Européen de Normalisation Electrotechnique  
Europäisches Komitee für Elektrotechnische Normung

**CEN-CENELEC Management Centre: Avenue Marnix 17, B-1000 Brussels**

## Foreword

The text of document 86B/3639/CDV, future edition 3 of IEC 61978-1, prepared by SC 86B "Fibre optic interconnecting devices and passive components" of IEC/TC 86 "Fibre optics" was submitted to the IEC-CENELEC parallel vote and approved by CENELEC as EN 61978-1:2014.

The following dates are fixed:

- latest date by which the document has to be implemented at national level by publication of an identical national standard or by endorsement (dop) 2015-03-27
- latest date by which the national standards conflicting with the document have to be withdrawn (dow) 2017-06-27

This document supersedes EN 61978-1:2010.

Attention is drawn to the possibility that some of the elements of this document may be the subject of patent rights. CENELEC [and/or CEN] shall not be held responsible for identifying any or all such patent rights.

## Endorsement notice

The text of the International Standard IEC 61978-1:2014 was approved by CENELEC as a European Standard without any modification.

In the official version, for Bibliography, the following notes have to be added for the standards indicated:

IEC 60068 Series	NOTE	Harmonized as EN 60068 Series.
IEC 60869-1	NOTE	Harmonized as EN 60869-1.
IEC 60874 Series	NOTE	Harmonized as EN 60874 Series.
IEC 60974 Series	NOTE	Harmonized as EN 60974 Series.
IEC 61073-1	NOTE	Harmonized as EN 61073-1.
IEC 61300-1	NOTE	Harmonized as EN 61300-1.
IEC 61300-2 Series	NOTE	Harmonized as EN 61300-2 Series.
IEC 61300-3 Series	NOTE	Harmonized as EN 61300-3 Series.
IEC 61753 Series	NOTE	Harmonized as EN 61753 Series.
IEC 61754 Series	NOTE	Harmonized as EN 61754 Series.
IEC 61754-4	NOTE	Harmonized as EN 61754-4.
IEC 61754-13	NOTE	Harmonized as EN 61754-13.
IEC 61754-15	NOTE	Harmonized as EN 61754-15.
IEC 62005 Series	NOTE	Harmonized as EN 62005 Series.

## Annex ZA (normative)

### Normative references to international publications with their corresponding European publications

The following documents, in whole or in part, are normatively referenced in this document and are indispensable for its application. For dated references, only the edition cited applies. For undated references, the latest edition of the referenced document (including any amendments) applies.

NOTE 1 When an International Publication has been modified by common modifications, indicated by (mod), the relevant EN/HD applies.

NOTE 2 Up-to-date information on the latest versions of the European Standards listed in this annex is available here: [www.cenelec.eu](http://www.cenelec.eu)

<u>Publication</u>	<u>Year</u>	<u>Title</u>	<u>EN/HD</u>	<u>Year</u>
IEC 60027 series		Letter symbols to be used in electrical technology	-	-
IEC 60050-731	-	International Electrotechnical Vocabulary (IEV) - Chapter 731: Optical fibre communication	-	-
IEC 60617 series	-	Standard data element types with associated classification scheme for electric components	-	-
IEC 60695-11-5	-	Fire hazard testing - Part 11-5: Test flames - Needle-flame test method - Apparatus, confirmatory test arrangement and guidance	EN 60695-11-5	-
IEC 60793-2-50	2012	Optical fibres - Part 2-50: Product specifications - Sectional specification for class B single-mode fibres	EN 60793-2-50	2013
IEC 60825 series	-	Radiation safety of laser products, equipment classification, requirements and user's guide	EN 60825 series	-
IEC 61300 series		Fibre optic interconnecting devices and passive components - Basic test and measurement procedures	EN 61300 series	-
IEC 61300-3-38	-	Fibre optic interconnecting devices and passive components - Basic test and measurement procedures - Part 3-38: Examinations and measurements - Group delay, chromatic dispersion and phase ripple	EN 61300-3-38	-
IEC Guide 102	-	Electronic components - Specification structures for quality assessment (Qualification approval and capability approval)	-	-
ISO 129-1	-	Technical drawings - Indication of dimensions and tolerances - Part 1: General principles	-	-
ISO 286-1	-	Geometrical product specifications (GPS) – ISO coding system for tolerances on linear sizes – Part 1: Basis of tolerances, deviations and fits	EN ISO 286-1	-
ISO 1101	-	Geometrical Product Specifications (GPS) – Geometrical tolerancing – Tolerances of form, orientation, location and run-out	-	-

<u>Publication</u>	<u>Year</u>	<u>Title</u>	<u>EN/HD</u>	<u>Year</u>
ISO 8601	-	Data elements and interchange formats - Information interchange - Representation of dates and times	-	-
IEC/TR 61930	-	Fibre optic graphical symbology	-	-

## CONTENTS

1	Scope.....	6
2	Normative references .....	6
3	Terms and definitions .....	7
3.1	Basic terms.....	7
3.2	Component terms .....	7
3.3	Performance parameter .....	8
4	Requirements .....	10
4.1	General.....	10
4.2	Classification .....	10
4.2.1	General .....	10
4.2.2	Type .....	10
4.2.3	Style .....	11
4.2.4	Variant.....	12
4.2.5	Normative reference extensions .....	12
4.3	Documentation.....	13
4.3.1	Symbols .....	13
4.3.2	Specification system.....	13
4.3.3	Drawings .....	14
4.3.4	Tests and measurements.....	15
4.3.5	Test data sheets .....	15
4.3.6	Instructions for use .....	15
4.4	Standardization system.....	15
4.4.1	Performance standards.....	15
4.4.2	Reliability standards .....	16
4.4.3	Interlinking.....	16
4.5	Design and construction.....	18
4.5.1	Materials .....	18
4.5.2	Workmanship.....	18
4.6	Performance .....	18
4.7	Identification and marking .....	18
4.7.1	General .....	18
4.7.2	Variant identification number .....	18
4.7.3	Component marking.....	19
4.7.4	Package marking .....	19
4.8	Packaging .....	19
4.9	Storage conditions .....	20
4.10	Safety .....	20
	Annex A (informative) Example of dispersion compensating fibre (DCF) technologies.....	21
	Annex B (informative) Example of fibre Bragg grating (FBG) technologies .....	23
	Annex C (informative) Example of virtually imaged phased array (VIPA) technologies .....	25
	Annex D (informative) Example of GT etalon technologies .....	27
	Annex E (informative) Technology dependent characteristics of PCDCs .....	28
	Bibliography.....	29

Figure 1 – Standards currently under preparation .....	17
Figure A.1 – Chromatic dispersion in a standard single-mode optical fibre (SMF) .....	21
Figure A.2 – Calculated contour for different dispersion at the wavelength of 1,55 $\mu\text{m}$ ( $CD(\lambda:1,55 \mu\text{m})$ ) for a step index core fibre .....	22
Figure A.3 – Examples of refractive index profile used in DCF .....	22
Figure B.1 – Illustration of the use of a chirped fibre Bragg grating for chromatic dispersion compensation .....	23
Figure B.2 – Expanded view over 10 nm of the insertion loss spectrum of a multi- channel FBG.....	24
Figure C.1 – Structure of virtually imaged phased array (VIPA).....	25
Figure C.2 – Detailed light path and mechanism of generating chromatic dispersion.....	26
Figure D.1 – Gires-Tournois etalon .....	27
Table 1 – Types of passive chromatic dispersion compensators .....	11
Table 2 – Three-level IEC specification structure .....	13
Table 3 – Standards interlink matrix.....	17
Table 4 – Quality assurance options .....	18
Table E.1 – Summary of technology dependent characteristics of PCDCs.....	28



# FIBRE OPTIC INTERCONNECTING DEVICES AND PASSIVE COMPONENTS – FIBRE OPTIC PASSIVE CHROMATIC DISPERSION COMPENSATORS –

## Part 1: Generic specification

### 1 Scope

This part of IEC 61978 applies to fibre optic passive chromatic dispersion compensators, all exhibiting the following features:

- they are optically passive;
- they have an optical input and an optical output for transmitting optical power;
- the ports are optical fibres or optical fibre connectors;
- they are wavelength sensitive;
- they may be polarization sensitive.

This standard establishes uniform requirements for the passive chromatic dispersion compensator.

### 2 Normative references

The following documents, in whole or in part, are normatively referenced in this document and are indispensable for its application. For dated references, only the edition cited applies. For undated references, the latest edition of the referenced document (including any amendments) applies.

IEC 60027 (all parts), *Letter symbols to be used in electrical technology*

IEC 60050-731, *International Electrotechnical Vocabulary – Chapter 731: Optical fibre communication*

IEC 60617 (all parts), *Graphical symbols for diagrams*

IEC 60695-11-5, *Fire hazard testing – Part 11-5: Test flames – Needle-flame test method – Apparatus, confirmatory test arrangement and guidance*

IEC 60793-2-50:2012, *Optical fibres – Part 2-50: Product specifications – Sectional specification for class B single-mode fibres*

IEC 60825 (all parts), *Safety of laser products*

IEC 61300 (all parts), *Fibre optic interconnecting devices and passive components – Basic test and measurement procedures*

IEC 61300-3-38, *Fibre optic interconnecting devices and passive components – Basic test and measurement procedures – Part 3-38: Examinations and measurements – Group delay, chromatic dispersion and phase ripple*

IEC TR 61930, *Fibre optic graphical symbology*

IEC Guide 102, *Electronic components – Specification structures for quality assessment (Qualification approval and capability approval)*

ISO 129-1, *Technical drawings – Indication of dimensions and tolerances – Part 1: General principles*

ISO 286-1, *Geometrical product specifications (GPS) – ISO coding system for tolerances of linear sizes – Part 1: Bases of tolerances and fits*

ISO 1101, *Geometrical Product Specifications (GPS) – Geometrical tolerancing – Tolerances of form, orientation, location and run-out*

ISO 8601, *Data elements and interchange formats – Information interchange – Representation of dates and times*

### 3 Terms and definitions

For the purposes of this document, the terms and definitions given in IEC 60050-731, as well as the following definitions apply.

#### 3.1 Basic terms

##### 3.1.1

##### **port**

optical fibre or optical fibre connector attached to a passive component for the entry and/or exit of optical power (input and/or output port)

#### 3.2 Component terms

##### 3.2.1

##### **passive chromatic dispersion compensator**

PCDC

two-port in-line passive device used to perform chromatic dispersion compensation

Note 1 to entry: PCDCs are commonly used to compensate the chromatic dispersion of an optical path by adding the opposite sign chromatic dispersion.

Note 2 to entry: The typical optical paths comprise single-mode fibre, dispersion shifted fibre and/or non-zero dispersion shifted fibre. PCDCs have either negative or positive chromatic dispersion values depending on the chromatic dispersion sign of the optical path.

##### 3.2.2

##### **dispersion compensating fibre**

DCF

speciality fibre to compensate for the chromatic dispersion of an optical path

##### 3.2.3

##### **passive DCF based dispersion compensator**

PCDC which constitutes DCF; realised by having chromatic dispersion characteristics of opposite sign to that of the optical path which are controlled the refractive index profile of the fibre

##### 3.2.4

##### **fibre Bragg grating**

FBG

fibre type optical device which has modulated refractive index profile in the core

### 3.2.5

#### **passive FBG based dispersion compensator**

PCDC which constitutes a FBG; PCDC is realised by a chirped FBG which has gradually changing refractive index along the fibre axis

### 3.2.6

#### **virtually imaged phased array**

VIPA

optical device having a glass plate with a highly reflective mirror

Note 1 to entry: A VIPA has the same functions as a grating.

### 3.2.7

#### **passive VIPA based dispersion compensator**

PCDC which consisting of a VIPA, focusing lens and 3-dimensional mirror

Note 1 to entry: PCDC produces both positive and negative chromatic dispersion by the movement of the 3-dimensional mirror to compensate for the chromatic dispersion of an optical path.

### 3.2.8

#### **etalon**

optical cavity which consists of a pair of parallel reflective mirrors

### 3.2.9

#### **Gires-Tournois etalon**

GT etalon

etalon having a highly reflective mirror and a half mirror

Note 1 to entry: The GT etalon is sometimes called a GT interferometer.

### 3.2.10

#### **passive GT etalon based dispersion compensator**

PCDC which comprises a GT etalon

## 3.3 Performance parameter

### 3.3.1

#### **chromatic dispersion compensation**

process by which a specific amount of chromatic dispersion is removed in order to mitigate the system impairment caused by unwanted dispersion

### 3.3.2

#### **group delay**

time by which a pulse is delayed by an optical device

Note 1 to entry: The group delay generally varies with the operating wavelength.

### 3.3.3

#### **chromatic dispersion**

derivative of group delay with respect to wavelength or frequency

Note 1 to entry: A typical unit is ps/nm or ps/GHz. The chromatic dispersion generally varies with the operating wavelength.

Note 2 to entry: The units of ps/GHz are not commonly used; however, it is suitable for the evaluation of transmission system influence.

### 3.3.4

#### **dispersion slope**

derivative of chromatic dispersion with respect to wavelength or frequency

Note 1 to entry: A typical unit is ps/nm<sup>2</sup> or ps/GHz<sup>2</sup>. The unit of ps/GHz<sup>2</sup> is not commonly used; however, it is suitable for the evaluation of transmission system influence.

Note 2 to entry: The dispersion slope generally varies with the operating wavelength

### **3.3.5 operating wavelength**

nominal wavelength  $\lambda$  at which a passive device operates with the specified performance

Note 1 to entry: Operating wavelength includes the wavelength to be nominally transmitted, attenuated and isolated.

### **3.3.6 operating wavelength range**

specified range of wavelengths including all operating wavelengths

Note 1 to entry: Operating wavelength range shall include all passbands when two or more the passbands are exist.

### **3.3.7 figure of merit**

FoM

ratio of the dispersion to the insertion loss of a PCDC at a particular operating wavelength

### **3.3.8 passband**

wavelength range within which a passive optical component is required to operate with optical attenuation less than or equal to a specified optical attenuation value

Note 1 to entry: There may be one or more passbands for a PCDC.

### **3.3.9 passband ripple**

maximum peak-to-peak variation of insertion loss in the passband

Note 1 to entry: The passband ripple of a PCDC is defined as the maximum passband ripple for all passbands.

### **3.3.10 group delay ripple**

GDR

maximum peak-to-peak variation of the group delay approximated by a desired function of wavelength (or frequency), typically a linear fit, within a channel wavelength (or frequency) range

### **3.3.11 phase ripple**

maximum peak-to-peak variation in measured phase spectrum when compared to a quadratic fit within a channel wavelength (or frequency) range

Note 1 to entry: Phase ripple (unit: radian) is calculated as the product of a peak-to-peak group delay ripple (unit: s) and a period of group delay ripple (unit: Hz). Refer to IEC 61300-3-38.

### **3.3.12 insertion loss**

reduction in optical power between an input and output port of a passive component expressed in decibels. It is defined as follows:

$$a = -10 \log \frac{P_a}{P_0}$$

where

$P_0$  is the optical power launched into the input port;

$P_a$  is the optical power received from the output port.

### 3.3.13

#### return loss

fraction of input power that is returned from a port of a passive component expressed in decibels. It is defined as follows:

$$RL = -10 \log \frac{P_r}{P_0}$$

where

$P_0$  is the optical power launched into a port;

$P_r$  is the optical power received back from the same port.

### 3.3.14

#### reflectance

ratio of the optical power returning back from a port to input power expressed in %

### 3.3.15

#### polarization dependent loss

PDL

maximum variation of insertion loss due to a variation of the state of polarization (SOP) over all the SOPs

### 3.3.16

#### wavelength dependent loss

WDL

maximum variation of the insertion loss over operating wavelength range

### 3.3.17

#### polarization mode dispersion

PMD

average delay of the travelling time between the two principal states of polarization (PSP), when an optical signal passes through an passive optical component

## 4 Requirements

### 4.1 General

The requirements for PCDCs covered by this clause are intended to aid in classifying this device in a relevant specification. Additional or more severe requirements may be imposed by the relevant blank detail specification and by the detail specification.

### 4.2 Classification

#### 4.2.1 General

PCDCs shall be classified as follows:

- type;
- style;
- variant;
- normative reference extensions.

#### 4.2.2 Type

PCDCs can be categorized into different types, as follows:

- by operating technologies (DCF, FBG, VIPA, GT etalon and so on);
- by dispersion compensating performance (for example, wavelength dispersion compensating, dispersion slope compensating);
- by operating wavelength range (for example, O-band, C-band, L-band);
- by categories of transmission fibre which PCDCs are applied (for example, IEC 60793-2-50:2012, B1, B2, B4).

The application of PCDCs and the suitable operating mechanisms are summarized in Table 1.

**Table 1 – Types of passive chromatic dispersion compensators**

Applications	Channel number	Passbands	Technologies
TDM (Time division multiplexing)	Single channel	Narrow	Dispersion compensating fibre (DCF) Fibre Bragg grating (FBG) GT etalon
WDM (Wavelength division multiplexing)	Single channel	Narrow	FBG
	Multi-channel <sup>a</sup>	Narrow	FBG GT etalon Virtually imaged phased array (VIPA)
		Wide	DCF

<sup>a</sup> Multi-channel PCDCs can be used for a single channel use.

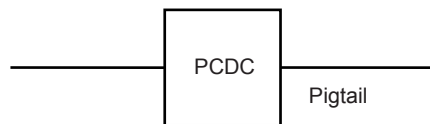
**4.2.3 Style**

**4.2.3.1 General**

PCDC may be classified into styles based on the fibre type(s), the connector type(s), cable type(s), housing shape, temperature control and the configuration. Style is not intended to define material or design. The configurations of PCDC ports are classified as follows.

**4.2.3.2 Configuration A**

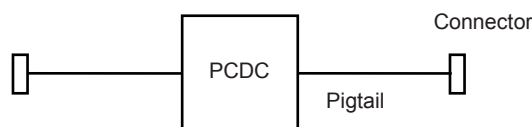
A device containing integral fibre optic pigtails, without connectors.



IEC 1687/2000

**4.2.3.3 Configuration B**

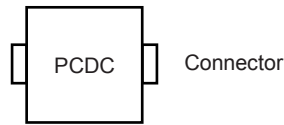
A device containing integral fibre optic pigtails, with a connector on each pigtail.



IEC 1688/2000

#### 4.2.3.4 Configuration C

A device containing fibre optic connectors as an integral part of the device housing.



IEC 1689/2000

#### 4.2.3.5 Configuration D

A device containing some combination of the interfacing features of the preceding configurations.

#### 4.2.4 Variant

The PCDC variant identifies those common features which encompass structurally similar components.

Examples of features which define a variant include, but are not limited to, the following:

- fibre type;
- connector type.

#### 4.2.5 Normative reference extensions

Normative reference extensions are used to identify integrated independent standards, specifications or other reference documents into blank detail specifications.

Unless a specified exception is noted, additional requirements imposed by an extension are mandatory. Usage is primarily intended to merge associated components to form hybrid devices, or integrated functional application requirements that are dependent on technical expertise other than fibre optics.

Published reference documents produced by ITU consistent with the scope statements of the relevant IEC specification series may be used as an extension. Published documents produced by other regional standardization bodies such as TIA, ETSI, JIS, etc., may be referenced in a bibliography attached to the generic specification.

Some optical fibre splice configurations require special qualification provisions that shall not be imposed universally. This accommodates individual component design configurations, specialized field tooling, or specific application processes. In this case, requirements are necessary to assure repeatable performance or adequate safety, and provide additional guidance for complete product specification. These extensions are mandatory whenever used to prepare, assemble or install an optical fibre splice either for field application usage or preparation of qualification test specimens. The relevant specification shall clarify all stipulations. However, design- and style-dependent extensions shall not be imposed universally.

In the event of conflicting requirements, precedence shall be given, in descending order, as follows: generic over mandatory extension, over blank detail, over detail, over application specific extension.

Examples of requirements for normative extensions are as follows:

- a) some commercial or residential building applications may require direct reference to specific safety codes and regulations or incorporate other specific material flammability or toxicity requirements for specialized locations;

- b) specialized field tooling may require an extension to implement specific ocular safety, electrical shock or burn hazard avoidance requirements, or require isolation procedures to prevent potential ignition of combustible gases.

### 4.3 Documentation

#### 4.3.1 Symbols

Graphical and letter symbols shall, whenever possible, be taken from the IEC 60027 series, IEC 60617 and IEC/TR 61930.

#### 4.3.2 Specification system

##### 4.3.2.1 General

This specification is part of a three-level IEC specification system. Subsidiary specifications shall consist of blank detail specifications and detail specifications. This system is shown in Table 2. There are no sectional specifications for passive dispersion compensators.

**Table 2 – Three-level IEC specification structure**

Specification level	Examples of information to be included	Applicable to
<b>Basic</b>	Inspection rules Optical measuring methods Environmental test methods Sampling plans Identification rule Marking standards Dimensional standards Terminology standards Symbol standards Preferred number series SI units	Two or more component families or subfamilies
<b>Generic</b>	Specific terminology Specific symbols Specific units Preferred values Marking Selection of tests	Component family
<b>Blank detail</b>	Quality conformance test schedule Inspection requirements Information common to a number of types	Groups of types having a common test schedule
<b>Detail</b>	Individual values Specific information Completed quality conformance test schedules	Individual type

##### 4.3.2.2 Blank detail specifications

The blank detail specification lists all of the parameters and features applicable to a PCDC, including the type, operating characteristics, housing configurations, test methods, and performance requirements. The blank detail specification is applicable to any PCDC design and quality assessment requirement. The blank detail specification contains the preferred format for stating the required information in the detail specification.



Blank detail specifications are not, by themselves, a specification level. They are associated with the generic specification.

Each blank detail specification shall be limited to one environmental category.

Each blank detail specification shall contain

- the minimum mandatory test schedules and performance requirements,
- one or more assessment levels,
- the preferred format for stating the required information in the detail specification,
- in case of hybrid components, including connectors, addition of appropriate entry fields to show the reference normative document, document title and issue date.

#### **4.3.2.3 Detail specifications**

A specific PCDC is described by a corresponding detail specification, which is prepared by filling in the blanks of the blank detail specification. Within the constraints imposed by this generic specification, the blank detail specification may be filled in by any national committee of the IEC, thereby defining a particular PCDC as an IEC standard.

Detail specifications shall specify the following, as applicable:

- type (see 4.2.2);
- style (see 4.2.3);
- variant(s) (see 4.2.4);
- part identification number for each variant (see 4.7.1);
- drawings, dimensions required (see 4.3.3);
- performance requirements (see 4.6).

### **4.3.3 Drawings**

#### **4.3.3.1 General**

The drawings and dimensions given in detail specifications shall not restrict themselves to details of construction, nor shall they be used as manufacturing drawings.

#### **4.3.3.2 Projection system**

Either first angle or third angle projection shall be used for the drawings in documents covered by this specification. All drawings within a document shall use the same projection system and the drawings shall state which system is used.

#### **4.3.3.3 Dimensional system**

All dimensions shall be given in accordance with ISO 129-1, ISO 286-1 and ISO 1101.

The metric system shall be used in all specifications.

Dimensions shall not contain more than five significant digits.

When units are converted, a note shall be added in each relevant specification and the conversion between systems of units shall use a factor of 25,4 mm to 1 inch.

#### **4.3.4 Tests and measurements**

##### **4.3.4.1 Test and measurement procedures**

The test and measurement procedures for optical, mechanical, climatic and environmental characteristics of passive dispersion compensators to be used shall be defined and selected preferentially from the IEC 61300 series.

The size measurement method to be used shall be specified in the detail specification for dimensions, which are specified within a total tolerance of 0,01 mm or less.

##### **4.3.4.2 Reference components**

Reference components for measurement purposes, if required, shall be specified in the relevant specification.

##### **4.3.4.3 Gauges**

Gauges, if required, shall be specified in the relevant specification.

##### **4.3.5 Test data sheets**

Test data sheets shall be prepared for each test conducted as required by a relevant specification. The data sheets shall be included in the qualification report and in the periodic inspection report.

Data sheets shall contain the following information as a minimum:

- title of test and date;
- specimen description including the type of fibre, connector or other coupling device. The description shall also include the variant identification number (see 4.7.2);
- test equipment used and date of latest calibration;
- all applicable test details;
- all measurement values and observations;
- sufficiently detailed documentation to provide traceable information for failure analysis.

##### **4.3.6 Instructions for use**

Instructions for use, when required, shall be given by the manufacturer and shall include

- assembly and connection instructions;
- cleaning method;
- safety aspects;
- additional information as necessary.

#### **4.4 Standardization system**

##### **4.4.1 Performance standards**

Performance standards contain a series of tests and measurements (which may or may not be grouped into a specified schedule depending on the requirements of that standard) with clearly defined conditions, severities, and “pass/fail” criteria. The tests are intended to be run on a “once-off” basis to prove any product’s ability to satisfy the “performance standards” requirement. Each performance standard has a different set of tests, and/or severities (and/or groupings) and represents the requirements of a market sector, user group or system location.

A product that has been shown to meet all the requirements of a performance standard can be declared as complying with a performance standard but should then be controlled by a quality assurance/quality conformance programme.

It is possible to define a key point of the test and measurements standards when these are applied (particularly with regard to insertion loss and return loss) in conjunction with the interface standards of inter product compatibility. This ensures conformance of each individual product to this standard,

#### **4.4.2 Reliability standards**

Reliability standards are intended to ensure that a component can meet performance specifications under stated conditions for a stated time period.

For each type of component, the following shall be identified (and appear in the standard):

- failure modes (ways in which a component can fail);
- failure mechanisms (causes of failure, which may be common to several components);
- failure effects (observable, general, mechanical or optical effects of failure).

These are all related to environmental and material aspects.

Initially, just after component manufacture, there is an “infant mortality phase” during which many components would fail if they were deployed in the field. To avoid early field failure, all components may be subjected to a screening process in the factory involving environmental stresses that may be mechanical, thermal or humidity-related. This is to induce known failure mechanisms in a controlled environmental situation to occur earlier than would normally be seen in the unscreened population. For those components that survive (and are then sold), there is a reduced failure rate, since these mechanisms have been eliminated.

Screening is an optional part of the manufacturing process, rather than a test method. It will not affect the “useful life” of a component defined as the period during which it performs according to specifications. Eventually other failure mechanisms appear, and the failure rate increases beyond the defined threshold. At this point the useful life ends and the “wear-out region” begins, and the component shall be replaced.

At the beginning of useful life, performance testing on a sampled population of components may be applied by the supplier, by the manufacturer or by a third party. This is to ensure that the component meets performance specifications over the range of intended environments at this initial time. Reliability testing, on the other hand, is applied to ensure that the component meets performance specifications for at least a specified minimum useful lifetime or specified maximum failure rate. These tests are usually carried out by utilizing the performance testing, but increasing duration and severity to accelerate the failure mechanisms.

A reliability theory relates component reliability testing to component parameters and to lifetime or failure rate under testing. The theory then extrapolates these to lifetime or failure rate under less stressful service conditions. The reliability specifications include values of the component parameters needed to ensure the specified minimum lifetime or maximum failure rate in service.

#### **4.4.3 Interlinking**

Standards currently under preparation are given in Figure 1. A large number of the test and measurements standards already exist, and quality assurance qualification approval already exists and has done so for many years. As previously mentioned, alternative methods of quality assurance/quality conformance are being developed under the headings of capability approval and technology approval which are covered in IEC Guide 102.

With regard to interface, performance and reliability standards, once all three of these standards are in place, the matrix given in Table 3 demonstrates some of the other options available for product standardization.

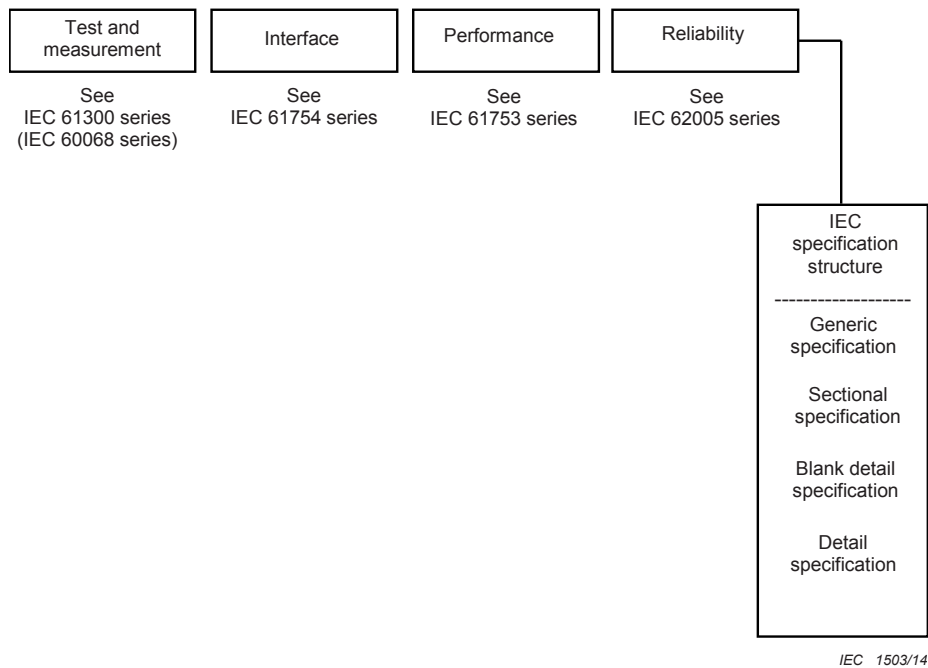
Product A is fully IEC standardized, having a standard interface and meeting defined performance and reliability standards.

Product B is a product with a proprietary interface but which meets a defined IEC performance and reliability standard.

Product C is a product that complies with an IEC standard interface but does not meet the requirements of either an IEC performance or reliability standard.

Product D is a product that complies with both an IEC standard interface and a performance standard but does not meet any reliability requirements.

Obviously, the matrix is more complex than shown since there will be a number of interface, performance and reliability standards which may cross-refer. In addition, the products may all be subject to a quality assurance programme that could be under IEC qualification approval, capability approval, technology approval (as Table 4 attempts to demonstrate), or even a national or company quality assurance system.



**Figure 1 – Standards currently under preparation**

**Table 3 – Standards interlink matrix**

Product group	Interface standard	Performance standard	Reliability standard
Product A	Yes	Yes	Yes
Product B	No	Yes	Yes
Product C	Yes	No	No
Product D	Yes	Yes	No

**Table 4 – Quality assurance options**

Product group	Company A			Company B			Company C		
	QA	CA	TA	QA	CA	TA	QA	CA	TA
Product A	X			X					X
Product B	X				X				X
Product C	X				X				X
Product D	X					X			X

## 4.5 Design and construction

### 4.5.1 Materials

#### 4.5.1.1 General

The devices shall be manufactured with materials which meet the requirements of the detail specification. When non-flammable materials are required, the requirement shall be specified in the relevant specification, and the test of IEC 60695-11-5 shall be cited as reference.

#### 4.5.1.2 Corrosion resistance

All materials used in the construction of compensator sets shall be corrosion resistant or suitably finished to meet the requirements of the relevant specification.

#### 4.5.1.3 Non-flammable materials

When non-flammable materials are required, the requirement shall be specified in the specification and IEC 60695-11-5 shall be referenced.

### 4.5.2 Workmanship

Components and associated hardware shall be manufactured to a uniform quality and shall be free of sharp edges, burrs or other defects that will affect life, serviceability or appearance. Particular attention shall be given to neatness and thoroughness of marking, plating, soldering, bonding, etc.

## 4.6 Performance

PCDCs shall meet the performance requirements specified in the relevant specification.

## 4.7 Identification and marking

### 4.7.1 General

Components, associated hardware and packages shall be permanently and legibly identified and marked when this is required by the relevant specification.

### 4.7.2 Variant identification number

Each variant in a detail specification shall be assigned a variant identification number. The number shall consist of the number assigned to the detail specification followed by a four-digit dash number and a letter designating the assessment level. The first digit of the dash number shall be sequentially assigned to each component type covered by the detail specification. The last three digits shall be sequentially assigned to each variant of the component.

EXAMPLE:

	QC940000/US0001 -1	001	A
Detail specification number			
Component type			
Variant number			
Assessment level			

#### 4.7.3 Component marking

Component marking, if required, shall be specified in the detail specification. The preferred order of marking is as follows:

- port identification;
- manufacturer's part number (including serial number, if applicable);
- manufacturer's identification mark or logo;
- manufacturing date;
- variant identification number;
- any additional marking required by the detail specification.

If space does not allow for all the required marking on the component, each unit shall be individually packaged with a data sheet containing all of the required information which is not marked.

#### 4.7.4 Package marking

Several PCDCs may be packed together for shipment.

Package marking, if required, shall be specified in the detail specification. The preferred order of marking is as follows:

- manufacturer's identification mark or logo;
- manufacturer's part number;
- manufacturing date code (year/week, see ISO 8601);
- variant identification number(s) (see 4.7.1);
- the type designation (see 4.2.2);
- the assessment level;
- any additional marking required by the detail specification.

When applicable, individual unit packages (within the sealed package) shall be marked with the reference number of the certified record of released lots, the manufacturer's factory identity code and the component identification.

#### 4.8 Packaging

Packages shall include instructions for use when required by the specification (see 4.3.6).

#### 4.9 Storage conditions

Where short-term degradable materials, such as adhesives, are supplied with the package of connector parts, the manufacturer shall mark these with the expiry date (year and week numbers, see ISO 8601) together with any requirements or precautions concerning safety hazards or environmental conditions for storage.

#### 4.10 Safety

PCDCs, when used on an optical fibre transmission system and/or equipment, may emit potentially hazardous radiation from an uncapped or unterminated output port or fibre end.

The PCDC manufacturers shall make available sufficient information to alert system designers and users about the potential hazard and shall indicate the required precautions and working practices.

In addition, each detail specification shall include the following:

#### **WARNING**

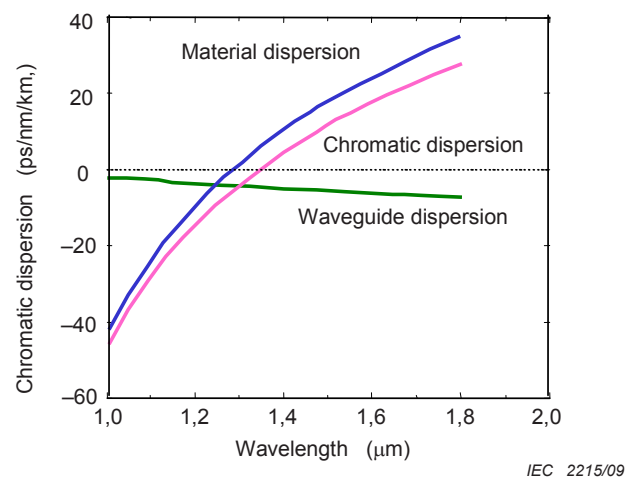
**Care should be taken when handling small diameter fibre to prevent puncturing the skin, especially in the eye area. Direct viewing of the end of an optical fibre or an optical fibre connector when it is propagating energy is not recommended, unless prior assurance has been obtained as to the safety energy output level.**

Reference shall be made to the IEC 60825 series, the relevant standard on safety.

## Annex A (informative)

### Example of dispersion compensating fibre (DCF) technologies

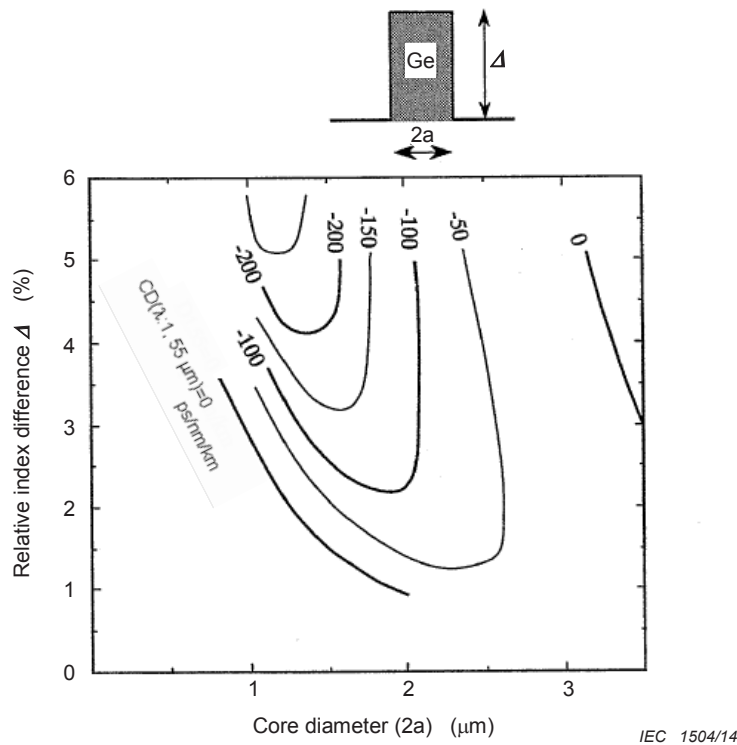
Chromatic dispersion in optical fibre is expressed as the sum of material dispersion caused by wavelength dependence of the refractive index of the glass materials and waveguide dispersion caused by index profile of optical fibre (Figure A.1). Silica glass optical fibre material dispersion does not vary greatly. Waveguide dispersion can be controlled by changing the index profile of the optical fibre. DCFs are designed to control waveguide dispersion to achieve the desired dispersion characteristics.



**Figure A.1 – Chromatic dispersion in a standard single-mode optical fibre (SMF)**

Figure A.2 shows the contour for different dispersions at a wavelength of 1,55 μm as a function of the relative refractive index difference,  $\Delta$ , from a pure silica cladding index value level and core diameter in a step-index profile with the germanium-doped silica core. From this figure, a DCF with a large negative chromatic dispersion can be obtained by increasing  $\Delta$  and decreasing the diameter of the core.

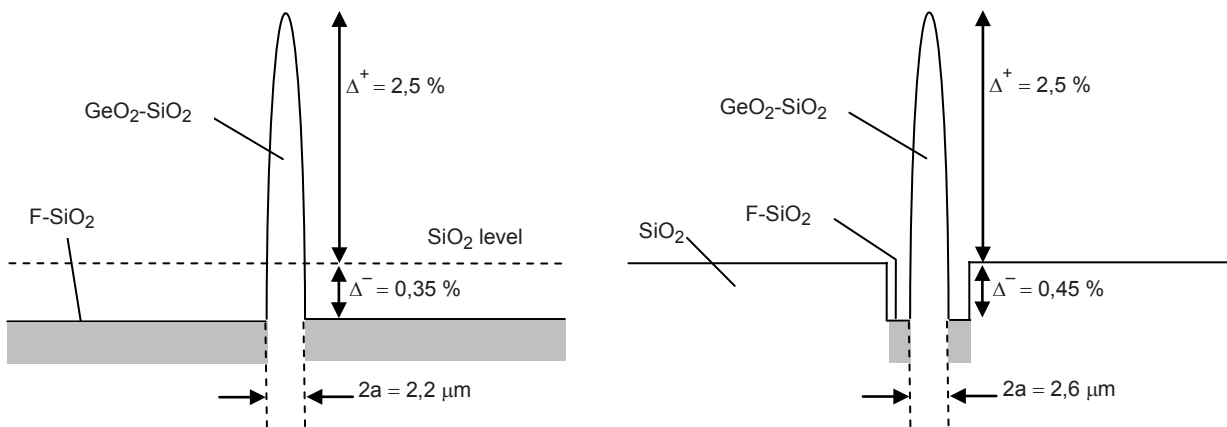




**Figure A.2 – Calculated contour for different dispersion at the wavelength of 1,55 μm (CD(λ:1,55 μm)) for a step index core fibre**

Figure A.3 shows two examples of refractive index profiles of DCFs. The relative refractive index difference between the core and the cladding is larger and the core diameter is smaller than those of standard single-mode fibres. These design differences result in larger waveguide dispersion. As for the double-cladding type DCF, much larger waveguide dispersion can be obtained than in the case of the matched cladding type DCF.

Double cladding type DCF can give negative dispersion slope in C-band and/or L-band. Because of this, the positive dispersion slope of SMFs (IEC 60793-2-50:2012, B1 fibres) can be compensated by using this type of DCF. Dispersion slope compensation is important to achieve a uniform dispersion value over the wavelength range of a WDM transmission system.



IEC 2217/09

IEC 2218/09

**Figure A.3a – Matched cladding type**

**Figure A.3b – Double cladding type**

**Figure A.3 – Examples of refractive index profile used in DCF**

## Annex B (informative)

### Example of fibre Bragg grating (FBG) technologies

Fibre Bragg grating (FBG) is a fibre type optical device that has a modulated refractive index profile in the core along the longitudinal axis. A FBG functions as a reflective filter where reflection wavelength is defined in Equation (B.1). Generally, refractive index modulation is generated by using UV radiation induced refractive index change.

$$\lambda_B = 2 \times \Lambda \times n_{\text{eff}} \quad (\text{B.1})$$

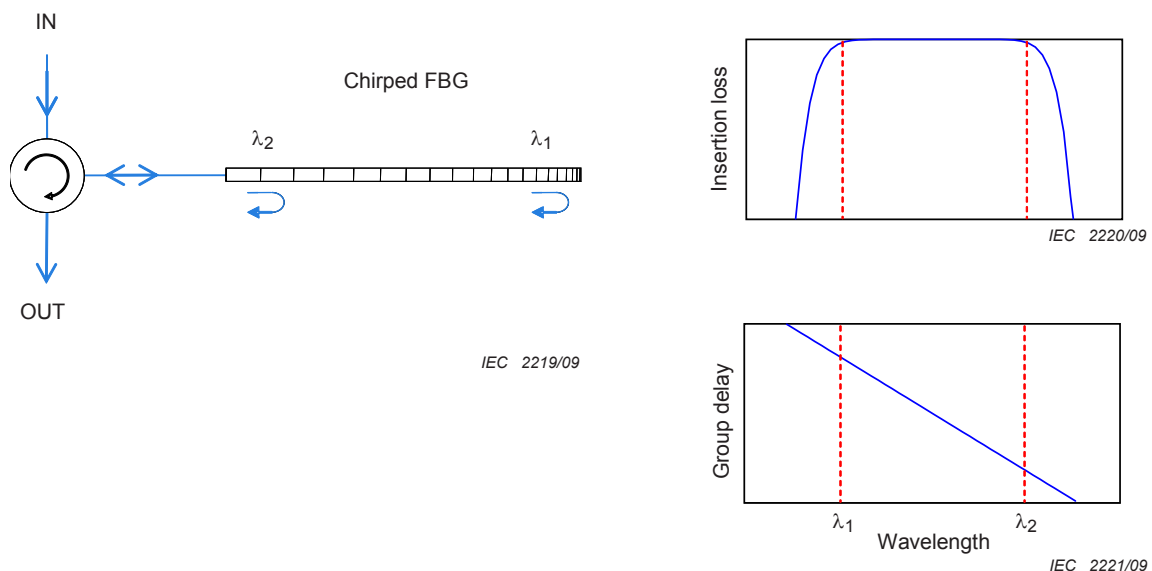
where

$\lambda_B$  is the reflection wavelength (Bragg wavelength);

$\Lambda$  is the refractive index modulation period;

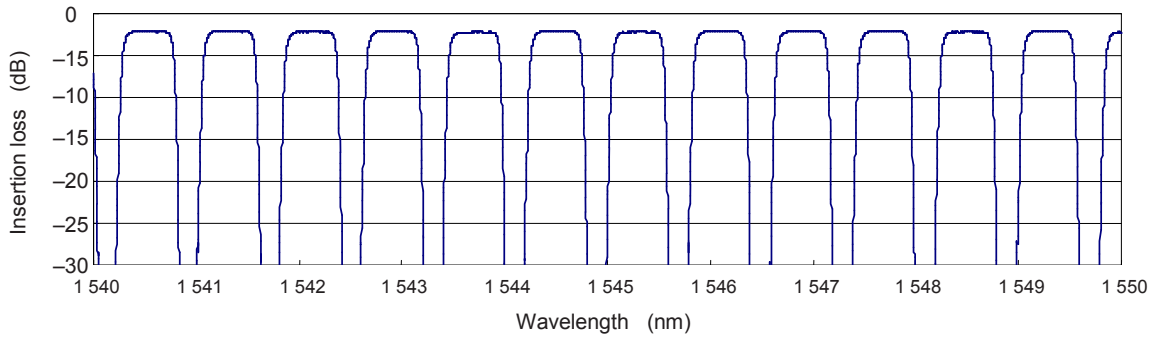
$n_{\text{eff}}$  is the effective refractive index.

The basic principle of dispersion compensation using a chirped FBG is shown in Figure B.1. In chirped FBG, grating period and/or effective refractive index are gradually changed and reflection wavelength changes along the fibre axis. After travelling through the transport fibre, the signal experiences a positive chromatic dispersion so that its longer part arrives before its shorter part. The chirped FBG provides more group delay for the longer part of the signal thus compensating for the effect of the chromatic dispersion. The slope of the group delay spectrum corresponds to the dispersion the FBG provides. To conveniently access the output signal, an optical circulator is used.



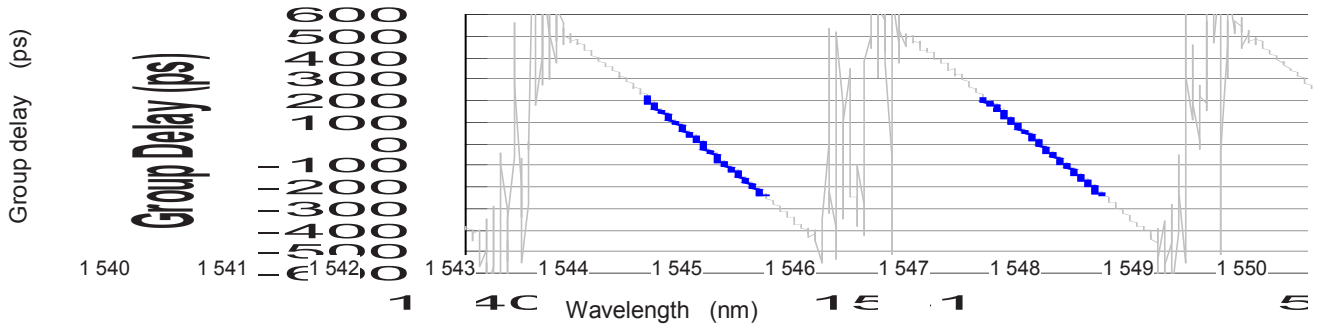
**Figure B.1 – Illustration of the use of a chirped fibre Bragg grating for chromatic dispersion compensation**

The FBG can be made multi-channel, allowing for a simultaneous compensation of the chromatic dispersion accumulated in all channels of a WDM system. The multi-channel character of the FBG is typically obtained through a sampling approach, that is, a spatial modulation of its physical properties. As an example, Figure B.2 shows an expanded view over 10 nm of the spectral characteristics of a multi-channels FBG tailored for compensating the chromatic dispersion accumulated over 100 km of single-mode fibre specified in IEC 60793-2-50:2012, category B1.



IEC 2222/09

Figure B.2a – Insertion loss including the optical circulator



IEC 2223/09

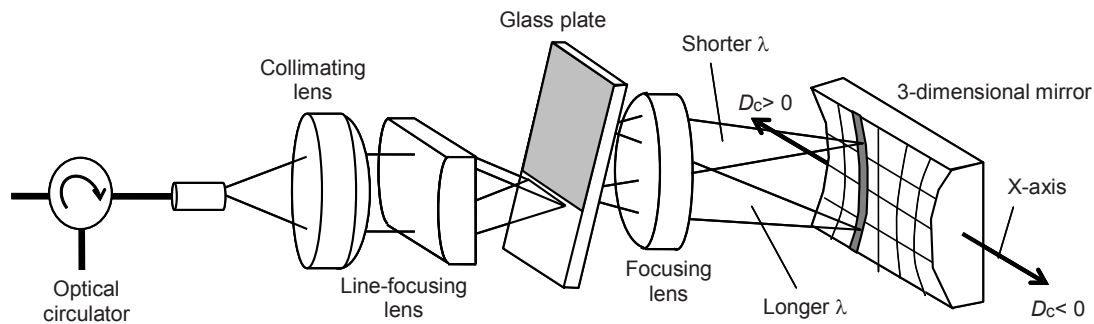
Figure B.2b – Group delay spectrum

Figure B.2 – Expanded view over 10 nm of the insertion loss spectrum of a multi-channel FBG

## Annex C (informative)

### Example of virtually imaged phased array (VIPA) technologies

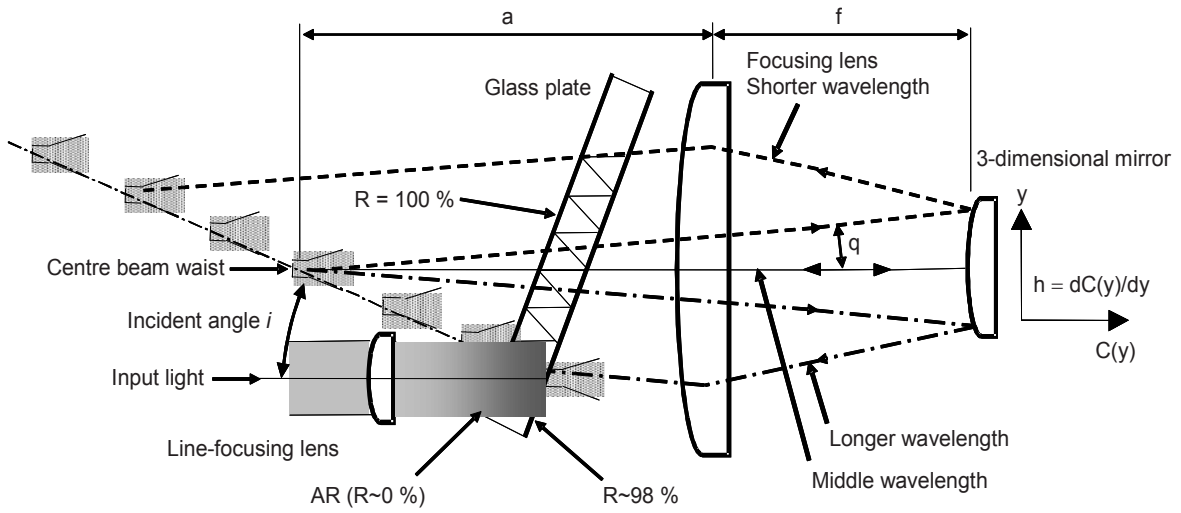
Figure C.1 shows the structure of a virtually imaged phased array (VIPA). The input light from a single-mode fibre is line-focused into a glass plate. The glass plate is coated on both surfaces and collimated light is emitted from the reverse side of the glass plate after multiple reflections between the coated surfaces. The light from the glass plate is then focused onto a curved mirror. The reflected light travels back to the glass plate and is finally coupled back into the fibre.



IEC 2224/09

**Figure C.1 – Structure of virtually imaged phased array (VIPA)**

Figure C.2 shows the detailed light path. Each time that the light is reflected at the right-angle surface of the glass plate, a small percentage of the power passes through the partially reflecting coating. This creates multiple beams that diverge from the corresponding beam waist in the virtual image. The interference of these diverging beams generates collimated light. This collimated light travels at an angle from the optical axis which varies with the wavelength. Chromatic dispersion, i.e. the wavelength dependence of distance travelled, is determined by the wavelength dependence of the pointing angle of collimated light from the glass plate and the surface profile of the reflection mirror. The convex portion of the mirror produces negative chromatic dispersion and the concave portion of the mirror produces positive chromatic dispersion. Figure C.1 shows that the collimated light (gray line area on the surface of the 3-D mirror) reflects along the concave mirror surface which produces positive chromatic dispersion. By shifting the position of the 3-D mirror along the X-axis, the collimated light can also reflect off the convex mirror surface, which produces negative chromatic dispersion. If the surface profile of the 3-D mirror is designed such that the curvature of the mirror's surface is gradually changed along the X-axis, the chromatic dispersion can be readily changed by shifting the 3-D mirror's position along the X-axis.



IEC 2225/09

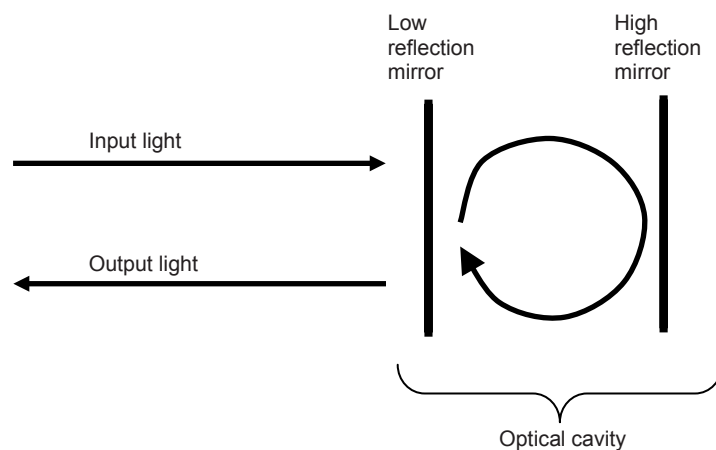
**Figure C.2 – Detailed light path and mechanism of generating chromatic dispersion**

## Annex D (informative)

### Example of GT etalon technologies

An etalon is an optical cavity which consists of a pair of parallel reflective mirrors. Multiple reflection interference between two filters gives cyclic spectrum and dispersion characteristics. The period of cyclic spectrum is called free spectral range (FSR). Operating wavelength and FSR can be adjusted by changing optical distance between the two mirrors.

There are mainly two types of etalons: Fabry-Perot (FP) etalon and Gires-Tournois (GT) etalon. The GT etalon (Figure D.1) is suitable for dispersion compensation. The GT etalon is an optical cavity that consists of mirrors having different reflectivity. Generally, the front mirror has low reflectivity and rear mirror has high reflectivity. In this case, the reflection power spectrum is relatively smooth, although the phase of the reflected light depends strongly on the wavelength. Using a multiple cavity etalon with optimized design, higher order dispersion can be compensated. Sometimes a GT etalon is called a GT interferometer.



IEC 2226/09

Figure D.1 – Gires-Tournois etalon

## Annex E (informative)

### Technology dependent characteristics of PCDCs

As described in Annexes A to D, mainly four technologies are used for PCDCs. Table E.1 shows the summary of technology-dependent characteristics of PCDCs.

**Table E.1 – Summary of technology dependent characteristics of PCDCs**

	DCF	FBG	VIPA	Etalon
Passband	Wide	Relatively narrow	Narrow/periodical	Narrow/periodical or wide
GDR period	No GDR	Typically approx. 10 pm	Typically approx. 2 pm	Typically approx. 30 pm
Loss dependency on dispersion	Yes	No	No	No
Non linearity	Yes	No	No	No
Tuneable function	No	Yes	Yes	Yes

## Bibliography

IEC 60068 (all parts), *Environmental testing*

IEC 60410, *Sampling plans and procedures for inspection by attributes*

IEC 60869-1, *Fibre optic interconnecting devices and passive components – Fibre optic passive power control devices – Part 1: Generic specification*

IEC 60874 (all parts), *Fibre optic interconnecting devices and passive components – Connectors for optical fibres and cables*

IEC 60974 (all parts), *Arc welding equipment*

IEC 61073-1, *Fibre optic interconnecting devices and passive components – Mechanical splices and fusion splice protectors for optical fibres and cables – Part 1: Generic specification*

IEC 61300-1, *Fibre optic interconnecting devices and passive components – Basic test and measurement procedures – Part 1: General and guidance*

IEC 61300-2 (all parts), *Fibre optic interconnecting devices and passive components – Basic test and measurement procedures – Part 2: Tests*

IEC 61300-3 (all parts), *Fibre optic interconnecting devices and passive components – Basic test and measurement procedures – Part 3: Examinations and measurements*

IEC 61753 (all parts), *Fibre optic interconnecting devices and passive components performance standard*

IEC 61754 (all parts), *Fibre optic interconnecting devices and passive components – Fibre optic connector interfaces*

IEC 61754-4, *Fibre optic interconnecting devices and passive components – Fibre optic connector interfaces – Part 4: Type SC connector family*

IEC 61754-13, *Fibre optic interconnecting devices and passive components – Fibre optic connector interfaces – Part 13: Type FC-PC connector*

IEC 61754-15, *Fibre optic interconnecting devices and passive components – Fibre optic connector interfaces – Part 15: Type LSH connector family*

IEC TR 61931, *Fibre optic – Terminology*

IEC 62005 (all parts), *Reliability of fibre optic interconnecting devices and passive components*

---





# British Standards Institution (BSI)

BSI is the national body responsible for preparing British Standards and other standards-related publications, information and services.

BSI is incorporated by Royal Charter. British Standards and other standardization products are published by BSI Standards Limited.

## About us

We bring together business, industry, government, consumers, innovators and others to shape their combined experience and expertise into standards-based solutions.

The knowledge embodied in our standards has been carefully assembled in a dependable format and refined through our open consultation process. Organizations of all sizes and across all sectors choose standards to help them achieve their goals.

## Information on standards

We can provide you with the knowledge that your organization needs to succeed. Find out more about British Standards by visiting our website at [bsigroup.com/standards](http://bsigroup.com/standards) or contacting our Customer Services team or Knowledge Centre.

## Buying standards

You can buy and download PDF versions of BSI publications, including British and adopted European and international standards, through our website at [bsigroup.com/shop](http://bsigroup.com/shop), where hard copies can also be purchased.

If you need international and foreign standards from other Standards Development Organizations, hard copies can be ordered from our Customer Services team.

## Subscriptions

Our range of subscription services are designed to make using standards easier for you. For further information on our subscription products go to [bsigroup.com/subscriptions](http://bsigroup.com/subscriptions).

With **British Standards Online (BSOL)** you'll have instant access to over 55,000 British and adopted European and international standards from your desktop. It's available 24/7 and is refreshed daily so you'll always be up to date.

You can keep in touch with standards developments and receive substantial discounts on the purchase price of standards, both in single copy and subscription format, by becoming a **BSI Subscribing Member**.

**PLUS** is an updating service exclusive to BSI Subscribing Members. You will automatically receive the latest hard copy of your standards when they're revised or replaced.

To find out more about becoming a BSI Subscribing Member and the benefits of membership, please visit [bsigroup.com/shop](http://bsigroup.com/shop).

With a **Multi-User Network Licence (MUNL)** you are able to host standards publications on your intranet. Licences can cover as few or as many users as you wish. With updates supplied as soon as they're available, you can be sure your documentation is current. For further information, email [bsmusales@bsigroup.com](mailto:bsmusales@bsigroup.com).

## BSI Group Headquarters

389 Chiswick High Road London W4 4AL UK

## Revisions

Our British Standards and other publications are updated by amendment or revision.

We continually improve the quality of our products and services to benefit your business. If you find an inaccuracy or ambiguity within a British Standard or other BSI publication please inform the Knowledge Centre.

## Copyright

All the data, software and documentation set out in all British Standards and other BSI publications are the property of and copyrighted by BSI, or some person or entity that owns copyright in the information used (such as the international standardization bodies) and has formally licensed such information to BSI for commercial publication and use. Except as permitted under the Copyright, Designs and Patents Act 1988 no extract may be reproduced, stored in a retrieval system or transmitted in any form or by any means – electronic, photocopying, recording or otherwise – without prior written permission from BSI. Details and advice can be obtained from the Copyright & Licensing Department.

## Useful Contacts:

### Customer Services

**Tel:** +44 845 086 9001

**Email (orders):** [orders@bsigroup.com](mailto:orders@bsigroup.com)

**Email (enquiries):** [cservices@bsigroup.com](mailto:cservices@bsigroup.com)

### Subscriptions

**Tel:** +44 845 086 9001

**Email:** [subscriptions@bsigroup.com](mailto:subscriptions@bsigroup.com)

### Knowledge Centre

**Tel:** +44 20 8996 7004

**Email:** [knowledgecentre@bsigroup.com](mailto:knowledgecentre@bsigroup.com)

### Copyright & Licensing

**Tel:** +44 20 8996 7070

**Email:** [copyright@bsigroup.com](mailto:copyright@bsigroup.com)



...making excellence a habit.™