

BS EN 61975:2010



BSI Standards Publication

High-voltage direct current (HVDC) installations — System tests

bsi.

...making excellence a habit.™

Version correct as of 03/01/2015. (c) The British Standards Institution 2013 Licensed copy: Lee Shau Kee Library, HKUST. Version correct as of 03/01/2015. (c) The British Standards Institution 2013 Licensed copy: Lee Shau Kee Library, HKUST.

National foreword

This British Standard is the UK implementation of EN 61975:2010.

The UK participation in its preparation was entrusted to Technical Committee PEL/22, Power electronics.

A list of organizations represented on this committee can be obtained on request to its secretary.

This publication does not purport to include all the necessary provisions of a contract. Users are responsible for its correct application.

© BSI 2010

ISBN 978 0 580 58961 4

ICS 29.130.10; 31.080.01

Compliance with a British Standard cannot confer immunity from legal obligations.

This British Standard was published under the authority of the Standards Policy and Strategy Committee on 31 October 2010.

Amendments issued since publication

Date	Text affected
------	---------------

English version

**High-voltage direct current (HVDC) installations -
System tests
(IEC 61975:2010)**

Installations en courant continu
à haute tension (CCHT) -
Essais système
(CEI 61975:2010)

Anlagen zur
Hochspannungsgleichstromübertragung
(HGÜ) -
Systemprüfungen
(IEC 61975:2010)

This European Standard was approved by CENELEC on 2010-09-01. CENELEC members are bound to comply with the CEN/CENELEC Internal Regulations which stipulate the conditions for giving this European Standard the status of a national standard without any alteration.

Up-to-date lists and bibliographical references concerning such national standards may be obtained on application to the Central Secretariat or to any CENELEC member.

This European Standard exists in three official versions (English, French, German). A version in any other language made by translation under the responsibility of a CENELEC member into its own language and notified to the Central Secretariat has the same status as the official versions.

CENELEC members are the national electrotechnical committees of Austria, Belgium, Bulgaria, Croatia, Cyprus, the Czech Republic, Denmark, Estonia, Finland, France, Germany, Greece, Hungary, Iceland, Ireland, Italy, Latvia, Lithuania, Luxembourg, Malta, the Netherlands, Norway, Poland, Portugal, Romania, Slovakia, Slovenia, Spain, Sweden, Switzerland and the United Kingdom.

CENELEC

European Committee for Electrotechnical Standardization
Comité Européen de Normalisation Electrotechnique
Europäisches Komitee für Elektrotechnische Normung

Management Centre: Avenue Marnix 17, B - 1000 Brussels

Foreword

The text of document 22F/221/FDIS, future edition 1 of IEC 61975, prepared by SC 22F, Power electronics for electrical transmission and distribution systems, of IEC TC 22, Power electronic systems and equipment, was submitted to the IEC-CENELEC parallel vote and was approved by CENELEC as EN 61975 on 2010-09-01.

Attention is drawn to the possibility that some of the elements of this document may be the subject of patent rights. CEN and CENELEC shall not be held responsible for identifying any or all such patent rights.

The following dates were fixed:

- latest date by which the EN has to be implemented
at national level by publication of an identical
national standard or by endorsement (dop) 2011-06-01
- latest date by which the national standards conflicting
with the EN have to be withdrawn (dow) 2013-09-01

Annex ZA has been added by CENELEC.

Endorsement notice

The text of the International Standard IEC 61975:2010 was approved by CENELEC as a European Standard without any modification.

In the official version, for Bibliography, the following notes have to be added for the standards indicated:

IEC/TR 60919-1	NOTE	Harmonized as CLC/TR 60919-1.
IEC 61000-4-3	NOTE	Harmonized as EN 61000-4-3.
IEC 61803	NOTE	Harmonized as EN 61803.

Annex ZA (normative)

Normative references to international publications with their corresponding European publications

The following referenced documents are indispensable for the application of this document. For dated references, only the edition cited applies. For undated references, the latest edition of the referenced document (including any amendments) applies.

NOTE When an international publication has been modified by common modifications, indicated by (mod), the relevant EN/HD applies.

<u>Publication</u>	<u>Year</u>	<u>Title</u>	<u>EN/HD</u>	<u>Year</u>
IEC 60633	1998	Terminology for high-voltage direct current (HVDC) transmission	EN 60633	1999
IEC/TR 60919-2	2008	Performance of high-voltage direct current (HVDC) systems with line-commutated converters - Part 2: Faults and switching	CLC/TR 60919-2	201X ¹⁾

¹⁾ At draft stage.

CONTENTS

FOREWORD.....	4
INTRODUCTION.....	6
1 Scope.....	7
2 Normative references.....	7
3 Terms and definitions	7
3.1 Test classifications terms	7
3.2 Operation state terms	8
4 General	9
4.1 Purpose.....	9
4.2 Structure of the HVDC system	10
4.3 Structure of the control and protection system.....	11
4.4 Logical steps of system test.....	12
4.5 Structure of system test	13
4.6 Precondition for site test	13
5 Converter station test.....	16
5.1 General	16
5.2 Converter unit test	17
5.3 Energizing of reactive components.....	18
5.4 Changing the d.c. system configuration.....	19
5.5 Electromagnetic compatibility.....	20
5.6 Trip test.....	21
5.7 Open line test	22
5.8 Back-to-back test.....	24
5.9 Short circuit test	25
6 Transmission tests.....	26
6.1 Low power transmission tests	26
6.2 Operator control mode transfer	34
6.3 Changes of d.c. configuration	40
6.4 Main circuit equipment switching.....	43
6.5 Dynamic performance testing.....	47
6.6 AC and d.c. system staged faults	56
6.7 Loss of telecom, auxiliaries or redundant equipment	60
6.8 High power transmission tests	63
6.9 Acceptance tests	67
7 Trial operation	74
7.1 General	74
7.2 Purpose of test	74
7.3 Test precondition.....	74
7.4 Test procedure	74
7.5 Test acceptance criteria.....	75
8 System test plan and documentation	75
8.1 General	75
8.2 Plant documentation and operating manual.....	75
8.3 System study reports and technical specification.....	75
8.4 Inspection and test plan	76
8.5 System test program.....	76

8.6	Test procedure for each test	77
8.7	Documentation of system test results	77
8.8	Deviation report	78
	Bibliography	79
	Figure 1 – Relation among five major aspects of system test	10
	Figure 2 – Structure of the HVDC system	11
	Figure 3 – Structure of the HVDC control and protection	11
	Figure 4 – Structure of system test	15
	Figure 5 – Sequence for low power transmission tests	28
	Figure 6 – Step response test of current control at the rectifier	49
	Figure 7 – Step response test of extinction angle control at the inverter	50
	Figure 8 – Step response test of d.c. voltage control at the inverter	50
	Figure 9 – Step response test of current control at the inverter	51
	Figure 10 – Step response test of power control at the rectifier	51

INTRODUCTION

The standard is structured in eight clauses:

- a) Clause 1 – Scope
- b) Clause 2 – Normative references
- c) Clause 3 – Definitions
- d) Clause 4 – General
- e) This clause addresses the purpose of this standard, the HVDC system structure, the control and protection structure, the logical steps of commissioning, the structure of the system test and that of the system commissioning standard.
- f) Clause 5 – Converter station test
- g) This clause addresses the commissioning of converter units and verifies the steady state performance of units as well as switching tests.
- h) Clause 6 – Power transmission tests
- i) This clause concerns the commissioning of the transmission system, and verifies station coordination, steady-state and dynamic performance, interference, as well as interaction between the d.c. and a.c. systems.
- j) Clause 7 – Trial operation
- k) After completion of the system test, the period of trial operation is normally specified to verify the normal transmission.
- l) Clause 8 – System test plan and documentation

Clauses 5 to 7 comprise individual sections providing an introduction and covering objects, preconditions and procedures and general acceptance criteria as well as detailed descriptions of the individual tests.

HIGH-VOLTAGE DIRECT CURRENT (HVDC) INSTALLATIONS – SYSTEM TESTS

1 Scope

This International Standard applies to system tests for high-voltage direct current (HVDC) installations which consist of a sending terminal and a receiving terminal, each connected to an a.c. system.

The tests specified in this standard are based on bidirectional and bipolar high-voltage direct current (HVDC) installations which consist of a sending terminal and a receiving terminal, each connected to an a.c. system. The test requirements and acceptance criteria should be agreed for back-to-back installations, while multi-terminal systems and voltage sourced converters are not included in this standard. For monopolar HVDC installations, the standard applies except for bipolar tests.

For the special functions or performances that are claimed by specific projects, some extra test items not included in this standard should be added according to the technical specification requirements.

This standard only serves as a guideline to system tests for high-voltage direct current (HVDC) installations. The standard gives potential users guidance, regarding how to plan commissioning activities. The tests described in the guide may not be applicable to all projects, but represent a range of possible tests which should be considered.

Therefore, it is preferable that the project organization establishes the individual test program based on this standard and in advance assigns responsibilities for various tasks/tests between involved organisations (e.g. user, supplier, manufacturer, operator, purchaser etc.) for each specific project.

2 Normative references

The following referenced documents are indispensable for the application of this document. For dated references, only the edition cited applies. For updated references, the latest edition of the referenced document (including any amendments) applies.

IEC 60633:1998, *Terminology for high-voltage direct current (HVDC) power transmission*

IEC/TR 60919-2:2008, *Performance of high-voltage direct current (HVDC) systems with line commutated converters – Part 2: Faults and switching*

3 Terms and definitions

For the purposes of this document, the terms and definitions given in IEC 60633 as well as the following terms and definitions apply.

3.1 Test classifications terms

3.1.1 station test

converter system test including items which verify the function of individual equipment of the converter station in energized state

3.1.2 system test

test verifying functions and performances of HVDC system as a whole as well as the interaction with adjacent a.c. systems

3.1.3 transmission tests

test verifying functions and performances of HVDC system when transmitting power between both terminals

NOTE It is also referred to as an “end to end test”.

3.2 Operation state terms

In the d.c. system, there are 5 defined states: earthed, stopped, standby, blocked, de-blocked.

3.2.1 earthed

state in which the pole or converter is isolated and earthed on the a.c. and d.c. sides and no energizing of the pole or converter equipment is possible

NOTE The earthed state provides the necessary safety for carrying out maintenance work, and is the only one that permits the pole or converter maintenance. In this state maintenance work is possible on the converter transformers, the isolated and earthed part of the a.c. high voltage bus equipment, d.c. and valve hall installed equipment of this pole or converter.

3.2.2 stopped/isolated

state in which the pole or converter is isolated from the a.c. and d.c. side, but all the earthing switches are open

NOTE In this state the d.c. yard can be prepared for power transmission (earth electrode line, pole and d.c. line connect).

3.2.3 standby

state which is to be used when the d.c. system is not being utilized but is ready for power transmission

NOTE In this state the converter transformer is to be ready; tap-changer is automatically brought to the start position, which ensures that the transformer will be energized with minimum voltage to minimize the inrush current. The disconnector of the a.c. bay should be closed, but the circuit breakers in the feeding bay of the converter transformer should be open. In this state the d.c. configuration can still be changed (earth electrode line, pole and d.c. line connect).

3.2.4 blocked

state in which the pole is prepared to transmit power at a moment's notice

NOTE The converter transformer is connected to the energized a.c. bus by means of closing of the respective circuit breaker. The valve cooling system is ready for operation if the cooling water conductivity, flow and temperature are within the specified limits. A defined d.c. configuration shall have been established. Further changes are not possible in this state. The thyristor pre-check is carried out after the converter transformer has been energized. The pre-check is considered as passed when in every valve the redundancy is not lost. To change the blocked state, the states stopped, standby and de-blocked are selectable.

3.2.5 de-blocked

state representing the following two operating modes: power transmission and open line test

NOTE Power transmission is the normal operating mode. In the de-blocked status the pole transmits power in normal operating mode if both terminals are in the deblocked stage and there is a voltage difference between the terminals. A minimum number of a.c. filters should be available.

3.2.6

off-site tests

tests which are performed before on-site testing

4 General

4.1 Purpose

System test completes the commissioning of an HVDC system.

The supplier can verify the suitability of the station equipment installed and the functional completeness of the system. Moreover, adjustments and optimizations can be made.

It is shown for the user that the requirements and stipulations in the contract are met and that there is correlation with studies and previous off-site tests.

For the user, the completion of system test marks the beginning of commercial operation of the HVDC system.

When adapting the HVDC system to the connected a.c. systems, there may be various constraints which require coordination within the economic schedules of the a.c. system operators. System tests prove to the public that tolerable values of phenomena concerning the public interest are not exceeded.

Five major aspects are subject to system tests:

- a) HVDC station equipment and d.c. line/cable/bus including earth electrode, if any;
- b) HVDC control and protection equipment and their settings;
- c) environmental considerations;
- d) a.c./d.c. system interaction;
- e) system performance when jointly operated with a connected a.c. system.

The interrelation between these aspects is shown in Figure 1.

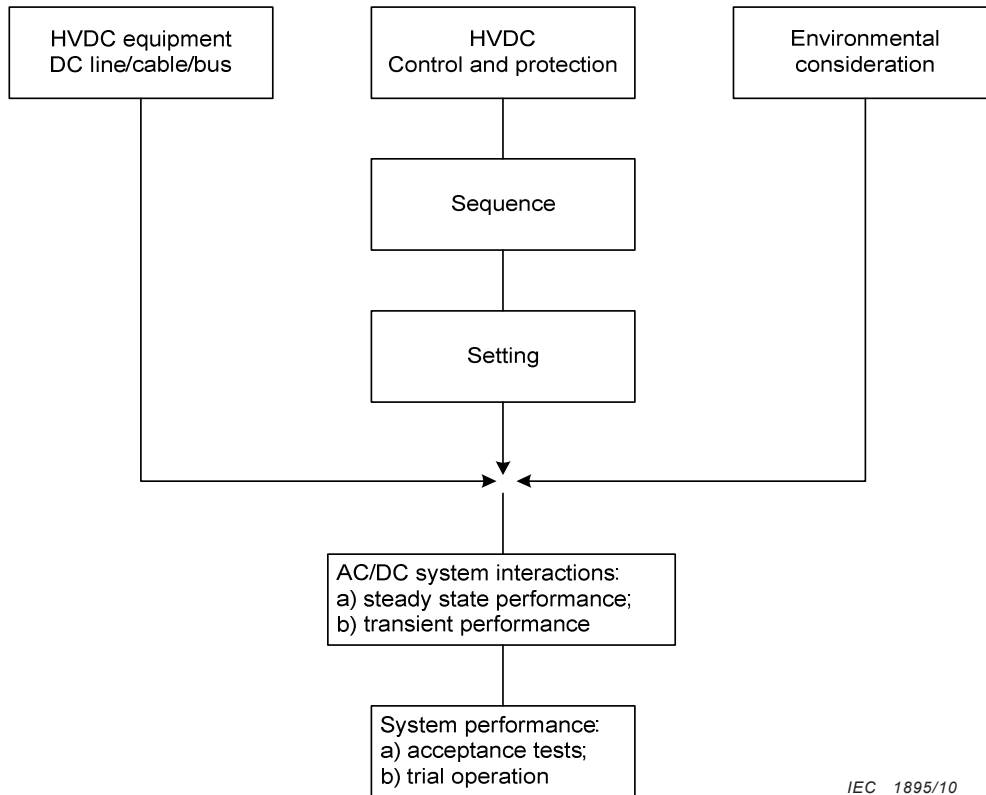

Figure 1 – Relation among five major aspects of system test

Thorough and complete system test of the above components can be achieved with the tests described in the standard.

Acceptance tests shall be defined between supplier and user in advance and may be performed at an appropriate time during the test schedule.

System tests may affect more than the actual contract parties. Those parties shall be informed in time.

The complexity and the diversified areas concerned during system test require thorough planning and scheduling, cooperation of all involved parties, as well as complete and organized documentation.

NOTE The suggested “Test Procedures” are recommendations and alternative test procedures may be used subject to the agreement between supplier and user.

4.2 Structure of the HVDC system

From a functional point of view an HVDC system consists of a sending terminal and a receiving terminal, each connected to an a.c. system. The two terminals have one or several converters connected in series on the d.c. side and in parallel on the a.c. side. The terminals are connected by a transmission line or cable or a short piece of busbar (back-to-back station). Multi-terminal systems are not addressed in this standard.

The structure of the HVDC system is shown in Figure 2.

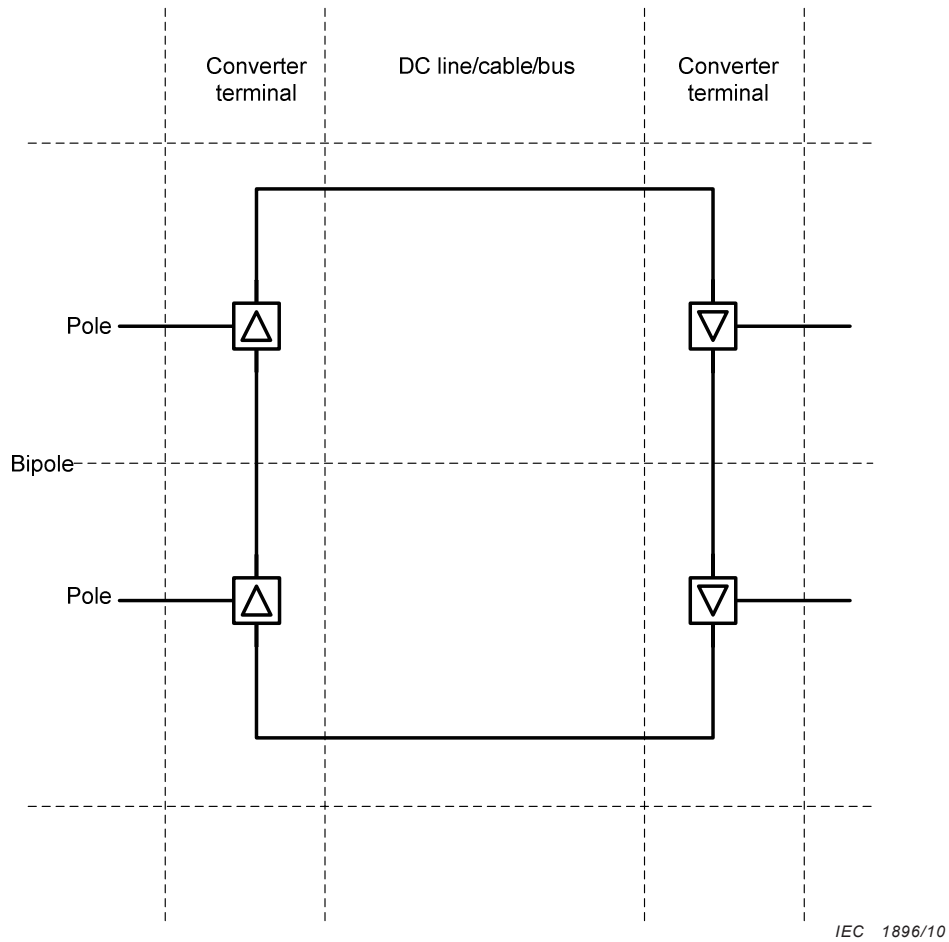

Figure 2 – Structure of the HVDC system

IEC 1896/10

4.3 Structure of the control and protection system

Each of the converter units can be controlled individually. To make the system function correctly as a power transmission system, the converter units should be controlled in a coordinated way by a higher level of the control system. Coordinated controls and protection are essential for the proper functioning of HVDC systems.

The structure of the HVDC control and protection is shown in Figure 3:

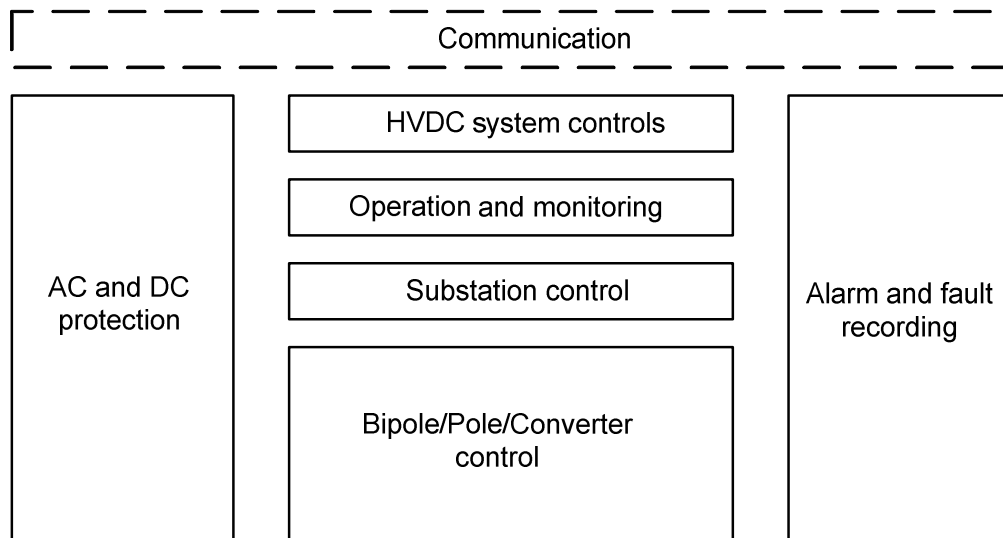

Figure 3 – Structure of the HVDC control and protection

IEC 1897/10

4.4 Logical steps of system test

To ensure proper functioning, the type test and functional performance test should be conducted in factory in order to debug and test the control system before the site test.

In order to provide the power grid data and help to compile the system test plan, the off-line digital simulation should be conducted before and during the simulation test, especially analysis on the power flow, stability and overvoltage.

Considering the complexity of the HVDC system, all limiting design cases may be conducted on the digital simulator in a similar way to those done on site.

Commissioning an HVDC system may affect more than the actual contract parties. The complexity and the diversified areas concerned during system test require thorough planning and scheduling, cooperation of all involved parties and complete and structured documentation. Before a system test can begin on site, the following preconditions should be fulfilled concerning subsystem tests, operator training and safety instructions, system test plan and test procedures, and all necessary test equipment.

- a) All subsystems should have been tested and commissioned, including a.c. filters and the converter transformers with special attention to possible transformer or a.c. filter resonance during energizing.
- b) Operating personnel should be sufficiently trained.
- c) Operating instructions for the station should be available.
- d) Personnel, plant safety and security instructions should be available.
- e) System test plan and documentation (Part 8) should be available and agreed upon.
- f) AC/d.c. power profiles should have been agreed for each test.
- g) Any a.c./d.c. system operating restrictions should have been identified.
- h) Operator voice communications should be available
- i) All necessary test equipment should have been calibrated and in service.
- j) Procedures for the preparation and evaluation of test results should have been agreed upon.

Site system tests should follow the structure of the HVDC system, starting from the smallest, least complex operational unit, usually a 12-pulse converter, and shall end with the total system in operation. The test sequence should be scheduled starting at the local level with simple tests before involving additional locations and the transmission system and more complex tests.

After all preconditions are fulfilled, converter station tests should be conducted and begin from the converter unit test, including energizing of a.c. filter and d.c. yard, electrical magnetic interference, trip test, changing the d.c. system configuration, open line test, and so on.

The power transmission (also called end-to-end) test should start on a monopolar basis, with bipolar operation, with full power being the final step.

Having the complete system running properly, performance of the steady state can be verified. With normal operating ramp settings and automatic switching sequences in place, the effect of a number of disturbances on the d.c. side of the system as well as in the a.c. systems may be checked, and the transient and fault recovery performances may be verified.

Acceptance tests shall be defined between supplier and user in advance and may be performed at an appropriate time during the test schedule.

The acceptance tests necessary to verify whether acceptance criteria have been met, may have been performed wholly or in part during the commissioning period. To avoid unnecessary

duplication of such tests, careful consideration should be given in advance as to when acceptance tests are carried out.

If acceptance tests are still outstanding or acceptance tests have to be repeated due to modifications, they should be performed during the transmission testing, or following trial operation, if appropriate.

Correct operation of the HVDC system over an extended period of time is checked during the trial operation.

Complete and organized documentation of the system tests, which benefit both the supplier and the user, shall form part of the project documentation and contain all necessary data records, logs, etc, and if necessary a commentary and references.

After all the above HVDC system tests have been completed, all functions have been verified and the HVDC system can be handed over to the users.

4.5 Structure of system test

The structure of the system test is shown in Figure 4.

4.6 Precondition for site test

4.6.1 Factory system test

This subclause describes site tests and the commissioning of the HVDC controls at the factory, including real-time simulation test.

Subsequent to the routine test of the HVDC system control and protection equipment, it is normal practice to check the function of the HVDC control and protection equipment in a factory system test (= FST) prior to being shipped to site.

The factory system test provides the opportunity to set up the parameters of the control systems and to obtain a proof on the performance of the equipment relative to the specified requirements.

Performance of the protective functions of the converter, during various simulated faults, can also be checked. This enables the equipment to be partly commissioned off-site. It also provides the opportunity to detect and correct hardware and software errors or deficiencies in the control and protection systems.

The factory system test may use a real-time simulator and/or software models.

In the factory system test the complete control system shall be tested. Fault recorders and sequence of event recorders in case they are "stand alone equipment" may be excluded. If these recorders are not part of the factory system test, the validity of output signals to these equipment would be checked during the tests.

Finding and correcting hardware and software errors in the control system is an important function of the off-site test. Such faults are easier to find and correct off-site rather than during site tests and commissioning. Correcting such faults reduces the probability of disturbing the customer power system during the site system test.

4.6.2 Additional simulation test before site system test

If the a.c. network condition in commissioning stage is different from that in the HVDC design stage, the additional simulation test should be conducted, if specified by the user.

Off-line simulation software can be used to analyse short circuit capacity, overvoltage and power flow, while the real-time simulator may be used for the complete functional performance tests of the control system.

The additional simulations provide opportunities to:

- a) set up the parameters of the control systems and obtain a preliminary check on the performance of the equipment relative to the specified requirements;
- b) check performance of the protective functions of the converter during various simulated faults;
- c) find and correct hardware and software errors in the control system which are easier to find and correct off-site rather than during site tests and commissioning, and can reduce the probability of disturbing the customer power system during site system tests.

Tests	Configuration
<p style="text-align: center;">Converter station test</p> <ol style="list-style-type: none"> 1) Converter unit test 2) Energizing of reactive components <ul style="list-style-type: none"> • A.c. filters • Capacitor banks • Reactors 3) Changing the d.c. system configuration 4) Electromagnetic compatibility 5) Trip test 6) Open line test 7) <i>Back-to-back test</i> 8) <i>Short circuit test</i> <p>NOTE Tests in <i>Italic</i> are special load tests as per 5.1.2.5.</p>	 <p style="text-align: right;"><small>IEC 1898/10</small></p>
<p style="text-align: center;">Power transmission test</p> <ol style="list-style-type: none"> 1) Basic operation <ul style="list-style-type: none"> • Start and stop sequences and steady state operation • Protective blocking and tripping sequences • Power and current ramping 2) Operator control mode transfer <ul style="list-style-type: none"> • Control location • Control mode • Reactive power control mode • Operation voltage • D.c. power automatic control 3) Changes of d.c. configuration 4) Switching of primary equipment <ul style="list-style-type: none"> • Transformers and tap changers • A.c. filters and the reactive power compensation devices • D.c. filters 5) Dynamic performance testing 6) A.c. and d.c. system staged faults 7) Loss of telecom, auxiliaries or redundant equipment 8) Steady state performance <ul style="list-style-type: none"> • The measurement of the system parameters • Reactive power control end performance • Overload/Temperature rise • Harmonic performance and filter components rating • Audible noise • Loading tests • Electromagnetic interference test • Earth electrode test 	 <p style="text-align: right;"><small>IEC 1899/10</small></p> <p style="text-align: center;">Configuration</p>  <p style="text-align: right;"><small>IEC 1900/10</small></p>
Trial operation	

Figure 4 – Structure of system test

5 Converter station test

5.1 General

5.1.1 Environmental specifications

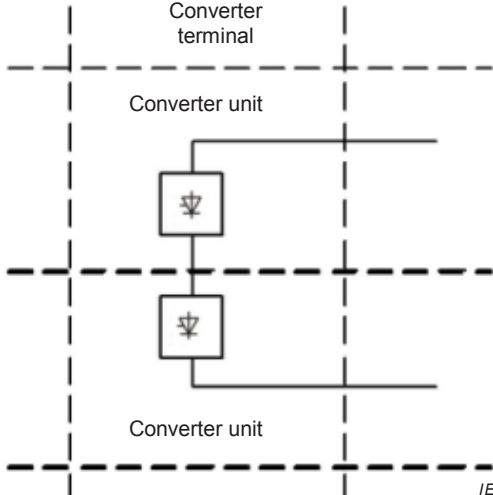
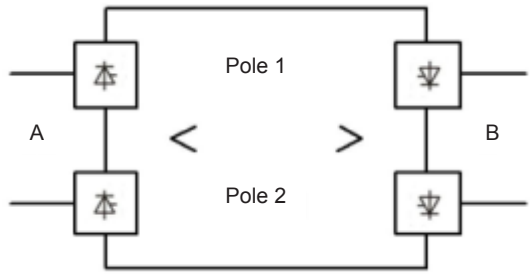
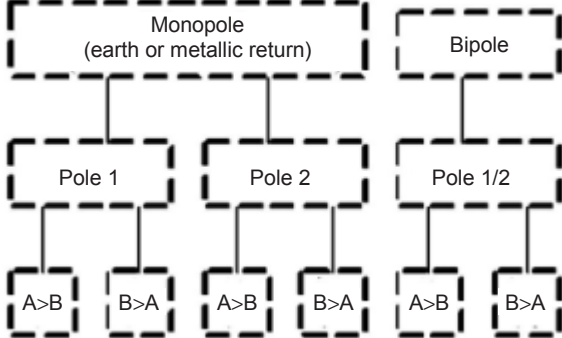
This clause describes the test of each converter station as a unit and the verification of the HVDC transmission line prior to transmitting power. This group of tests precedes the end-to-end test.

During the test program, conformance with environmental specifications should be included where applicable. Preliminary observations of audible noise, radio and PLC interference levels may be made, and temperature rise of major equipment can be monitored as described in Clause 6. However, the actual measurement of the above mentioned quantities should be conducted during end-to-end operation.

5.1.2 General purpose

5.1.2.1 General

The converter station test verifies the correct operation of an individual converter station and the proper insulation of all main circuit equipment before starting the power transmission tests.

The converter station tests may be divided into low voltage energizing, high voltage energizing, open line test and load tests.

5.1.2.2 Low voltage energizing / Phasing verification

In order to verify the phasing, the converter main circuit connections and the converter firing control a low voltage energizing test could be conducted prior to high voltage energizing. The test verifies the electrical phasing through the main circuit and the control system.

5.1.2.3 High voltage energizing

The high voltage energizing verifies that proper voltage insulation is achieved in the a.c. and d.c. main circuit equipment.

5.1.2.4 Open line test

The open line tests of the d.c. switchyard and d.c. transmission circuit verify that proper insulation voltage withstand has been achieved and that the converter firing control and the valve base electronics function properly.

5.1.2.5 Special load test

A load test (back-to-back or short circuit test) may be conducted, if specifically specified by the user, to get a provisional verification of the control system, the valve cooling capability and the main circuit with respect to temperature rise, audible noise and radio interference. Final verification will be made during power transmission test.

5.1.3 General precondition

Before beginning the converter test, the following equipment shall be verified off voltage and be available:

- a) a.c. switchgear;
- b) a.c. filters, capacitor banks and shunt reactors;
- c) d.c. filters and switchgear;

- d) converter transformers;
- e) thyristor valves and cooling system;
- f) station auxiliary service;
- g) fire protection system;
- h) a.c. and d.c. protection systems;
- i) control system;
- j) d.c. line or cable (for open line test);
- k) sequence of event recorder;
- l) alarm system;
- m) transient fault recorders.

Prior to the converter tests, detailed procedures and plans should be prepared. As the tests may involve some disturbance or increased risk to the connected a.c. systems, the operators of the systems should be consulted.

5.2 Converter unit test

5.2.1 Purpose of test

The test verifies that at the first energization of the converter unit the insulation voltage withstand is achieved, and checks that the electrical phasing is correct.

5.2.2 Test precondition

Test preconditions are the following:

- a) All controls and protections associated with the high voltage equipment shall be verified and in service. A trip test shall be made shortly before high voltage energizing (see 5.6).
- b) Monitoring instrumentation shall be connected and ready.
- c) All clamp joints shall have been tightened and the insulators wiped clean.
- d) The HVDC transmission line disconnect switch shall be opened and locked.
- e) All safety procedures shall have been carried out.
- f) A final visual inspection of the high voltage equipment shall be performed and the arrester counter numbers shall be recorded.
- g) The low voltage side of the valves shall be earthed.

5.2.3 Test procedure

5.2.3.1 Low voltage energizing

Test conditions are the following:

- a) During the test, all the internal reference voltages in the controls and the firing pulses of the valve control unit (=VCU) are monitored.
- b) The test may be performed by applying 0,5 to 10 kV to the primary side or to the valve side of the converter transformers with all thyristors short-circuited except one or more thyristors in each valve.
- c) An appropriate resistor or reactor may serve as a load on the d.c. side.
- d) Each single valve is represented by a single thyristor level. During the low voltage energizing test, the valves are de-blocked and the converter is operating in normal or open line test mode.

NOTE An alternative approach to verify the phasing of the converter main circuit connections and the interconnections to the converter transformers is a thorough visual inspection of the interconnection scheme and

comparison with the relevant documentation. This will however include verification that the control sends out a firing pulse to the correct thyristor.

5.2.3.2 High voltage energizing

Test conditions are the following:

- a) Energize the converter transformer with the valves blocked and check the electrical phasing through the control system.
- b) Ensure that the converter transformer tap changers initially at highest position (lowest valve side voltage) and then are stepped to rated voltage.
- c) Keep the transformer energized for a minimum of 6 h.
- d) Record a.c. voltage, steady-state and inrush-current, and inspect the equipment for abnormal sounds and corona discharge during the test.

5.2.3.3 Test acceptance criteria

The test acceptance criteria are the following:

- a) No abnormal sound or corona discharge shall occur in the energized equipment.
- b) No protection shall operate improperly.
- c) Parameters, such as voltage, should be as expected.

5.3 Energizing of reactive components

5.3.1 Individual energizing of reactive components

Reactive components, such as a.c. filters, capacitor banks and shunt reactors are energized for the first time individually. Combined switching of these elements is described in Clause 6.

5.3.2 Purpose of test

Purposes of the test are the following:

- a) to verify that proper voltage insulation is achieved;
- b) to verify that the a.c. filters, capacitor banks and shunt reactors are balanced between the three phases;
- c) to confirm the no-load currents and voltages of the protections, if any.

5.3.3 Test precondition

Test preconditions are the following:

- a) All controls and protections (main and backup) associated with the high voltage equipment shall be verified and in service. A trip test shall be made shortly before high voltage energizing.
- b) AC filter tuning shall be completed.
- c) AC filters and shunt capacitors shall have been balanced.
- d) All clamp joints shall have been tightened and the insulators wiped clean.
- e) All safety procedures shall have been carried out.
- f) A final visual inspection of the high voltage equipment shall be performed, and the arrester counter numbers shall be recorded.

5.3.4 Test procedure

Test procedure is the following:

- a) Energize the a.c. filters, capacitor banks and shunt reactors one by one.

- b) Keep each a.c. filter, capacitor bank and shunt reactor energized for a minimum of 2 h.
- c) Record a.c. voltage, steady-state and inrush current, and inspect the equipment for abnormal sounds and corona discharge during the test.

5.3.5 Test acceptance criteria

The test acceptance criteria are the following:

- a) No abnormal sound or corona discharge shall occur in the energized equipment.
- b) No protection shall operate improperly.
- c) The a.c. filters and capacitor banks shall be balanced within design tolerances.

5.4 Changing the d.c. system configuration

5.4.1 General

Changing the d.c. system configuration can be relatively simple in an end to end or point to point system which has a single converter per pole. The switching operations become more complicated if the station poles have parallel or series converters. This test demonstrates that equipment, breakers, disconnectors or earthing switches are operated in the correct sequence and, are properly interlocked. Changing the d.c. system configuration on load is described in Clause 6.

Transfers between different d.c. system configurations can be initiated automatically and jointly or manually from local control or from a remote dispatch centre. In manual or separate control, the operators need to coordinate these actions via voice communication.

5.4.2 Purpose of test

The test verifies that the d.c. system configuration can be safely changed as specified prior to transmitting power for the first time.

5.4.3 Test precondition

Test preconditions are the following:

- a) Off-site tests verifying d.c. system configuration change shall have been completed.
- b) All necessary a.c. and d.c. switching equipment shall be in service.
- c) Operator instructions and test procedures shall be available.

5.4.4 Test procedure

The transfer between specified d.c. system configurations shall be demonstrated. The changes of configuration should be performed from the initial conditions defined below:

- monopolar earth return;
- monopolar metallic return;
- bipolar operation;
- integration of parallel or series converters.

The tests shall first be performed with telecommunication out of service, and then with telecommunication in service.

- a) Establish voice communication with the operators of the other terminal.
- b) Switch off the telecommunication.
- c) Reset all alarms.

- d) Select the initial d.c. system configuration in accordance with the operating instructions. The procedure will have to be done in steps involving operators at each terminal.
- e) Verify the appropriate switching action on the operator control interface and sequence of events recorder. Simulate failures in the switching sequence.
- f) Repeat the test for all applicable d.c. system configurations.
- g) Restore telecommunication.
- h) Repeat the tests, in automatic and joint control mode.

5.4.5 Test acceptance criteria

The test acceptance criteria are the following:

- a) Switching sequences shall correctly transfer between all applicable d.c. system configurations, with and without telecommunication.
- b) All switching sequences shall be safely and correctly completed.
- c) The interlocking of earthing switches, disconnect switches and breakers of the a.c. and d.c. yards shall be in accordance with the technical specifications.
- d) It should be possible to initiate a change of d.c. system configuration from local and, if available, from remote control locations.
- e) An incomplete sequence shall be terminated in a safe condition.

5.5 Electromagnetic compatibility

5.5.1 General

The test may be conducted, if specified by user, at each station and each pole individually.

5.5.2 Test precondition

Test preconditions are the following:

- a) All primary equipment in the a.c. and d.c. yard of the tested station should be off voltage.
- b) All controls and protections (main and backup) associated with the high voltage equipment shall be verified and in service.
- c) All alarm and monitoring (including recording sequence of events) systems shall be verified and in service.

All the cubicles of control and protection system and the devices in them are charged.

All safety procedures shall have been carried out.

A final visual inspection of the high voltage equipment shall be performed, and the arrester counter numbers shall be recorded.

The test equipment, such as walkie talkie or mobile telephones, should be checked and in service. Moreover, the emitting power of the test equipment should be within 3 W to 5 W.

5.5.3 Test procedure

5.5.3.1 General

Electromagnetic compatibility can utilize different interference sources, which are listed as follows.

5.5.3.2 Test procedure by emitting source

Test procedure is as follows:

- a) Ensure that the tested cubicles and devices of control and protection are energized.
- b) Verify that the door of the d.c. control cubicles is closed.
- c) Emitting source shall be placed at first at the front and then behind each cubicle door of the control panel and emitting shall be repeated three times in each position. The distance between the emitting source and cubicle doors of the control panel should be calculated according to IEC 61000-4-3. The duration of each emitting shall not be less than 10 s.
- d) Inspect the equipment during the test for abnormal sounds and actions.

5.5.3.3 Test procedure by switching on and off the a.c. busbar

Test procedure is the following:

- a) Ensure that all cubicles and devices of control and protection are energized.
- b) Switch on the disconnected a.c. busbar which is the nearest one to the control room of the station.
- c) Switch off the above busbar.
- d) Inspect the equipment during the test for abnormal sounds and actions.

5.5.4 Test acceptance criteria

There shall be no abnormal control actions during the test.

5.6 Trip test

5.6.1 General

The test should be conducted for each trip coil in the converter station and each pole before energizing of the a.c. filters and transformers.

5.6.2 Purpose of test

Purposes of the test are the following:

- a) Verify the function of the protective trip circuits of equipment in the converter station.
- b) Verify the sequence and performance of the protective trip.

5.6.3 Test precondition

Test preconditions are the following:

- a) All equipment in the a.c. and d.c. yard of the tested station should be off voltage.
- b) All controls and protections (main and backup) associated with the high voltage equipment shall be verified and in service.
- c) All alarm and monitoring (including recording sequence of events) systems shall be verified and in service.
- d) All safety procedures shall have been carried out.
- e) A final visual inspection of the high voltage equipment shall be performed, and the arrester counter numbers shall be recorded.

5.6.4 Test procedure

5.6.4.1 General

The trip signals can be initiated from different positions, as follows.

5.6.4.2 DC protection trip test

Initiate a trip signal on the terminal of the d.c. protective circuit tested, and the a.c. circuit breaker on the a.c. source side should be tripped out.

5.6.4.3 Protection trip test of the a.c. filter and shunt capacitor

Initiate a trip signal on the protection trip terminal of the a.c. filter and shunt capacitor tested, and the a.c. filter breaker should be tripped out.

5.6.4.4 Emergency switch off button trip test

Push down the emergency switch off button in the control room. The a.c. circuit breaker of the a.c. source side should be tripped out.

5.6.5 Test acceptance criteria

The test acceptance criteria are the following:

- a) The a.c. source side breaker of the converter transformer shall be tripped properly initiated by either d.c. protection or manually by the emergency switch off button.
- b) The a.c. source side breaker of each a.c. filter or shunt capacitor shall be tripped properly initiated by their protection trip circuit.
- c) No abnormal alarm or event shall occur.

5.7 Open line test

5.7.1 General

5.7.1.1 Necessity of the test

The open line test may be unnecessary where other tests items cover purposes of this test.

5.7.1.2 Open line test of the d.c. switchyard

Open line test of the d.c. switchyard can be performed from both terminals of the HVDC system at the time.

5.7.1.3 Open line test with the d.c. transmission circuit

Open line test of the d.c. transmission circuit, which can be performed from either terminal of the HVDC system but one at a time, can be conducted from the converter that becomes available first but preferably from the terminal with the highest operating voltage. The open line test can excellently demonstrate the condition of the HVDC lines and cables.

5.7.2 Test precondition

5.7.2.1 Open line test of the d.c. switchyard

Test preconditions are the following:

- a) The converter transformers shall have been energized.
- b) All controls and protections associated with the converter transformers and the d.c. switchyard, including the d.c. voltage dividers, shall have been verified and in service. A trip test shall be made shortly before high voltage energizing. Preferably a low voltage energizing shall have been performed.
- c) Monitoring instrumentation shall be connected and ready.
- d) All clamp joints shall have been tightened and the insulators wiped clean.

- e) The HVDC transmission line disconnect switch shall be opened and locked.
- f) All safety procedures shall have been carried out.
- g) A final visual inspection of the d.c. switchyard shall be performed and the arrester counter numbers shall be recorded.
- h) DC filter tuning shall have been completed.

5.7.2.2 Open line test with the d.c. transmission circuit

Test preconditions are the following:

- a) The d.c. switchyard shall have been successfully energized.
- b) All control and protection systems shall have been verified and be in service.
- c) The d.c. transmission circuit shall have been available.
- d) Check and confirm that the other terminal is isolated.
- e) Voice communication system shall be in service.
- f) All safety procedures shall have been carried out.
- g) The neutral side of the converter shall have been connected to the earth electrode and the high voltage side shall have to be connected to the power transmission line or cable.

5.7.3 Test procedure

5.7.3.1 Open line test of the d.c. switchyard

Test procedure is the following:

- a) Connect the neutral side of the converter to earth or to the earth electrode (if available).
- b) Energize the converter transformer at the lowest valve side voltage and step the tap changers to rated voltage.
- c) De-block the converter in the open line test status of operation and ramp the d.c. voltage slowly to rated value.
- d) Keep the d.c. equipment energized for a maximum of 30 min.
- e) After the successful completion of the test, decrease the d.c. voltage to zero and block the converter.
- f) Repeat the open line test of the d.c. switchyard with the appropriate d.c. filters connected one by one and then together.
- g) If there are multiple valve groups in each pole they should be initially energized individually and then together.
- h) During the test, a.c. and d.c. voltage and current shall be recorded. Inspect the equipment during the test for abnormal sounds, corona discharge or partial discharge arcing.

5.7.3.2 Open line test with the d.c. transmission circuit

Test procedure is the following:

- a) Energize the converter transformer and step the tap changer to rated voltage.
- b) De-block the converter in open line test status of operation and slowly ramp the d.c. voltage up to the desired level. Make sure that the d.c. voltage level does not exceed the voltage insulation level at the other end.
- c) After the successful completion of the test, decrease the d.c. voltage to zero and block the converter.
- d) Repeat the test for each line or cable and each pole, if applicable.
- e) Keep the d.c. transmission circuit energized for a maximum of 30 min.

- f) During the test, a.c. and d.c. voltage and current shall be recorded. Inspect the equipment during the test for abnormal sounds, corona discharge or partial discharge arcing.

NOTE Due to excessive leakage current of the d.c. line it may not be possible to reach the nominal d.c. voltage.

5.7.4 Test acceptance criteria

5.7.4.1 Open line test of the d.c. switchyard

The test acceptance criteria are the following:

- a) No abnormal sound or corona discharge shall occur in the energized equipment.
- b) No protection shall operate improperly.

The designed d.c. voltage can be achieved.

5.7.4.2 Open line test with the d.c. transmission circuit

The test acceptance criteria are the following:

- a) No protection shall operate improperly.
- b) With d.c. line open at the other end, sufficiently high d.c. voltage is built up.

5.8 Back-to-back test

5.8.1 General

For bipolar HVDC systems, if specified by the user, a back-to-back test may be considered if the transmission line is built late and both poles are ready. It is also considered in order to reduce disturbance to the connected a.c. system. Back-to-back test is accomplished by operating a bipolar terminal with one converter as rectifier and the other as inverter. The connection between the converters may be within the station or may include part or all of the d.c. transmission circuit. In the latter case an open line test of the transmission circuit should be conducted, as described in 5.7, prior to the test. The back-to-back test gives an effective general check of converter operation for a part load. Due to temporary adjustments and control modifications, this also poses additional risks.

The telecommunication system is not required for these tests. Adjustments to the control system may be necessary.

5.8.2 Purpose of test

The back-to-back test gets a provisional verification of the control system, the valve cooling capability and the main circuit with respect to temperature rise.

The test should permit troubleshooting at the individual terminal to provide for a more efficient end-to-end test procedure. Current control, power control and reactive power control checkout may be performed, with each converter pole operating both as rectifier and inverter.

5.8.3 Test precondition

Test preconditions are the following:

- The energizing tests of the a.c. filters, capacitor banks and shunt reactors shall have been successfully completed.
- The converter transformers, the valves (and the d.c. switchyard filters if available) and switchgear shall have been energized.
- A temporary connection between the converters or a part of the d.c. transmission circuit is required.
- The d.c. smoothing reactor shall be included in series with the converter units.

- Some control parameters should be temporarily adjusted for back-to-back test if appropriate.
- All safety procedures shall have been carried out.

Consideration shall be given to the possible trip of the converters during test. If a trip occurs, a protection scheme shall ensure that the station a.c. bus is adequately protected by limiting the level and duration of the voltage rise to acceptable values. This may be achieved by putting a limit on maximum allowable direct current. For a.c. systems with low short circuit ratio a tripping arrangement that removes all filters when a converter is blocked should be installed (if not already included).

5.8.4 Test procedure

The two converters shall be temporarily interconnected. The interconnection shall be adequate for maximum test current. The reactive power should vary with direct current similar to expected values during transmission operation. The harmonic a.c. filters and shunt banks shall be utilized to reduce maximum variation of reactive power exchange with the a.c. network. Tests and measurements should be made to verify:

- de-blocking and blocking of converters;
- ramping up to maximum test current including check of current measuring circuits;
- proper functioning of current control, power control, automatic tap changer control and reactive power control;
- the measured signals for the a.c. filters protection and for the transformer protection. Make adjustments if necessary;
- acceptable equipment temperatures and absence of hot spots;
- steady state and transient properties of the cooling system of the valves are correct;
- switching sequences in the auxiliary power system are correct and these should be done initially at low d.c. current levels;
- correct operation of redundancy arrangements, for instance by simulation of faults in units or functions, where redundancy is built into the equipment.

During back-to-back operation, even though the rectifier angle is kept close to the rated one, the angle may vary with different levels of direct currents and thus vary the phase angle between the harmonics from the rectifier and the inverter. At some point of operation some harmonics may be in phase opposition to each other, which will result in the filter current being very small. This should be kept in mind during the observation of loading of the a.c. filters.

5.8.5 Test acceptance criteria

The test acceptance criteria are the following:

- a) The converter should operate properly.
- b) Equipment temperatures shall be within specified limits. No hot spots should exist.
- c) No abnormalities should appear in the initial assessment of the cooling capability of the thyristor valves, transformers, reactors, building and valve hall.
- d) No protection shall operate improperly.

5.9 Short circuit test

5.9.1 General

If specified by the user, the short circuit test may be conducted on a monopolar d.c. system or in cases where schedules or other constraints do not allow each converter of a bipolar station to be used for back-to-back test.

5.9.2 Purpose of test

The test provides minimal verification of the control system before transmission test.

5.9.3 Test precondition

The preconditions for the short circuit test are the same as for the back-to-back test, described in 5.8. The d.c. smoothing reactor shall be included in series with the converter unit when creating the short circuit.

The d.c. circuit shall be operated short circuited with alpha at approximately 90° ($U_d = 0$) during this test. The large delay angle results in much higher than normal losses in the valve snubber circuits and valve arresters. As a precaution, the duration of the test should be limited and the cool down time between tests should be adequate.

Control and protection systems that would have operated as a result of the conditions during the test shall be disabled in a safe manner.

5.9.4 Test procedure

The test should be made with the converter transformer tap changer in highest position (lowest valve side voltage). Tests may verify the following ones:

- a) de-blocking and blocking;
- b) current control stability.

5.9.5 Test acceptance criteria

The current control system shall be stable.

6 Transmission tests

6.1 Low power transmission tests

6.1.1 General

6.1.1.1 General features

The low power transmission tests are a basic set of verifications that shall be conducted when the converter terminals are connected for the first time with the HVDC transmission circuit.

Since power will be transmitted, tests arrangement shall limit the potential impact to the HVDC system equipment and to the interconnected a.c. systems.

It shall perform basic operation tests in all applicable HVDC system configurations. The general test procedure is shown in the flow chart of Figure 5.

Some special verifications shall be done off voltage prior to test at any power level, which are included in the converter station tests (as described in Clause 5). In particular, the transfer between different d.c. system configurations and the verification of protective tripping sequences shall be done before tests at minimum power transfer level.

6.1.1.2 General precondition

General preconditions are the following:

- a) Off-site tests should have been completed.
- b) Converter unit tests for each station should have been completed.

- c) Where applicable, a back-to-back test or short circuit test should have been completed.
- d) Open line test of the HVDC transmission circuit should have been completed if applicable.
- e) Earth electrodes and earth electrode lines should have been checked and cleared.
- f) Inter-station telecommunication system and telephone system should be in service.
- g) The overall test procedures, safety rules, dispatch co-ordination and test responsibilities should have been established.
- h) Fire protection and detection systems should have been checked and in service.
- i) All control protection, metering, sequence of events and fault recording systems should have been checked and in service.

6.1.1.3 General purpose

Basic operation tests are intended to verify the proper co-ordination and inter-station interlocking of the basic HVDC control and protection functions at low power levels. The tests should be performed with various a.c. and d.c. system configurations and in applicable fault status. Changing the d.c. system configuration (as described in 7.3) or the status (as described in 7.2) of operation shall first be tested without high voltage (dry run test or off voltage test).

The tests should be compiled in such a way that all the control modes, control levels and control locations will be tested without unnecessary duplication of tests.

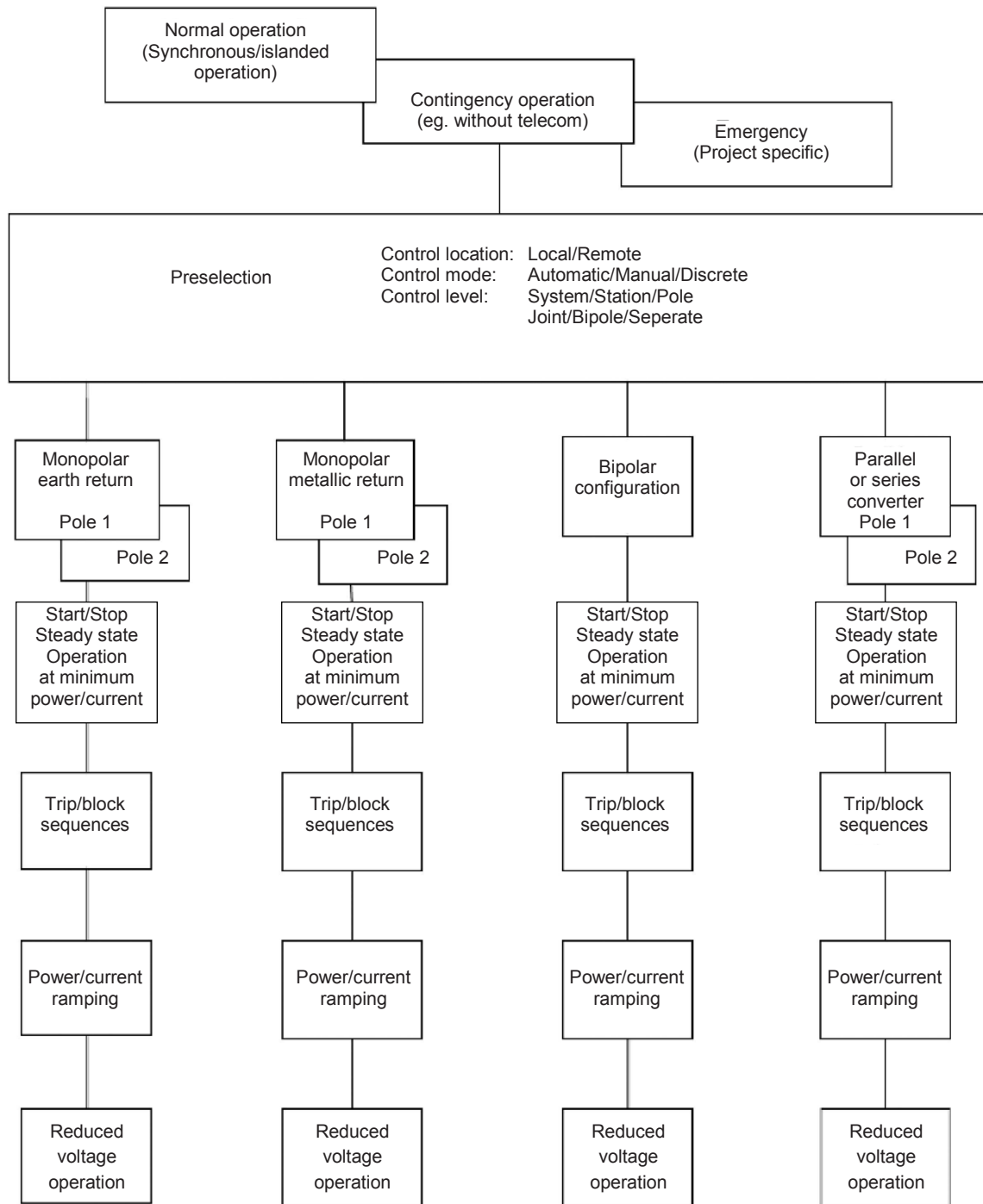

IEC 1901/10

Figure 5 – Sequence for low power transmission tests

6.1.2 Start and stop sequences and steady state operation at minimum power

6.1.2.1 General

When conducting the start and stop sequences for the first time, the thyristor valves will be de-blocked at the rectifier and inverter terminals and current will be established in the HVDC transmission circuit.

The converters starting and stopping sequences of HVDC systems may vary with the design philosophies and the system requirements. The general sequence of bringing a converter from stopped status to de-block is defined in Clause 3.

6.1.2.2 Purpose of test

Purposes of the test are the following:

- a) De-block each converter of the HVDC transmission system and transmit minimum power for the first time in both power directions, if applicable.
- b) Verify for each pole that control actions associated with each status change, start and stop sequences are executed in the right order.
- c) Verify that minimum power can be established and stopped smoothly and reliably in all applicable HVDC system configurations.
- d) Verify correct system measurements during steady state operation at minimum power.

6.1.2.3 Test precondition

Test preconditions are the following:

- a) The d.c. system configuration should have been tested off-voltage.
- b) Start and stop sequences should have been tested.
- c) Converter tests for each station should have been completed.
- d) Appropriate a.c. and d.c. filters should be available.
- e) The valve cooling equipment should have been verified and in operation.
- f) No alarm should be present.
- g) Thyristor monitoring should show that thyristor redundancy is not exceeded.
- h) Protective blocking and tripping sequences should have been tested off voltage. All protective lockouts should have been reset.
- i) Operator's instructions and test procedures should be available.
- j) The connected a.c. systems should be capable of delivering or accepting the transmitted power without affecting their stable operation.

6.1.2.4 Test procedure

Test procedure is the following:

- a) One of the a.c. and d.c. system configurations off voltage shall be established before the start and stop test.
- b) When the HVDC system configuration is established, the operational status may be tested beginning with "stopped" or "stand-by". The status change should be done off voltage. By changing the operation status to "blocked", voltage can be applied to the converters of each terminal.
- c) Establish voice communication between the operators at each terminal and ensure that telecommunication is working.
- d) Establish operation at minimum power by first de-blocking the inverter and then the rectifier.
- e) Remain at minimum power for a short period.

- f) Block the rectifier and the inverter.
- g) Establish operation at minimum power in automatic and joint mode.
- h) Remain at minimum power for at least one hour and verify measurements of d.c. currents, voltage etc.
- i) Redundant controls and other elements should be switched in order to verify that there is no impact on the HVDC transmission or the a.c. network.
- j) Throughout the test check and verify that no hot spots develop at the equipment, especially the converter valves, the converter transformers, the smoothing reactors, the wall bushings and all main circuit connections.
- k) Throughout the test verify that the valve cooling system maintains the valve temperature within specified limits.
- l) The start and stop test shall be repeated for all applicable system configurations and in both synchronous and islanded operation.
- m) If applicable, power transmission in the reverse power direction should be tested.

6.1.2.5 Test acceptance criteria

The test acceptance criteria are the following:

- a) Starting and stopping at minimum power shall be safely and reliably accomplished in each applicable HVDC system configuration.
- b) All control actions shall take place in correct order and specified time, and inter-station interlocking shall function properly.
- c) No malfunction shall occur.
- d) Equipment ratings shall not be exceeded.
- e) No a.c. and d.c. system disturbance shall occur.
- f) The cooling system shall keep the valve temperature within specified limits.
- g) Switching between redundant elements shall have no impact on the HVDC transmission.
- h) The main operation parameters of a.c. and d.c. systems shall be within design limits, including power, voltage and current at the d.c. side, and reactive power and voltages of each system at the a.c. side.

6.1.3 Protective blocking and tripping sequences

6.1.3.1 General

Depending on the type of fault, the protective blocking and tripping sequence may result in some combinations of the following actions:

- a) instantaneous advancing of the inverter firing angle (commutation failures);
- b) transfer to redundant control (if applicable);
- c) retarding the firing angle of the rectifier and/or the inverter;
- d) blocking of the converter valves (with or without firing of by-pass pairs);
- e) a.c. breaker tripping (converter transformers and possibly a.c. filters);
- f) pole isolation by opening d.c. switches;
- g) blocking of remote station;
- h) protective control sequences e.g. as a consequence of load rejection.

6.1.3.2 Purpose of test

Purposes of the test are the following:

- a) Verify that blocking or protective tripping sequences take place properly and selectively when clearing a fault or equipment malfunction.
- b) Verify that d.c. protective actions are properly co-ordinated with the a.c. breaker operation and other protections.
- c) Verify that control actions re-establish system transmission as specified.

6.1.3.3 Test precondition

Test preconditions are the following:

- a) The co-ordination between the protective systems and the control systems should have been demonstrated during off-site tests.
- b) The a.c. and d.c. protection systems should have been checked during subsystem and converter station tests.
- c) All control and protection systems are in service including redundant.
- d) All monitoring and alarm systems should be in service.
- e) Test personnel should have been well informed on each protection and on the protective actions to expect.
- f) Telecommunication system should be in service.
- g) The connected a.c. systems can deliver or accept the transmitted power without affecting their stable operation.
- h) All energizing tests of a.c. and d.c. equipment should have been completed.

6.1.3.4 Test procedure

In order to verify the proper function of a protective blocking or tripping sequence, the faults shall be simulated.

Test of the protective sequences should begin with tests off voltage.

After successful completion of the off voltage tests, trips should be simulated at minimum power in all applicable system configurations and with the telecommunication system in and out of service.

For each simulated fault, test personnel shall check the following conditions:

- the correct circuit breaker trips;
- the corresponding alarm;
- sequence of event recorder signals;
- each terminal being stopped safely (if necessary).

For each simulated fault, the following signals should be recorded:

- a) a.c. voltages and currents on each phase;
- b) d.c. voltages on both poles;
- c) a.c. currents in the valve winding on each phase;
- d) d.c. currents on each pole and on each d.c. neutral connection;
- e) a.c. currents in filter banks;
- f) main sequencing signals;
- g) protection signals;
- h) firing and extinction angles order and measurements;
- i) current order.

6.1.3.5 Test acceptance criteria

The test acceptance criteria are the following:

- a) For each simulated fault, the corresponding protective blocking and tripping sequence shall operate as expected/designed.
- b) The consequential outages of a fault shall be limited to the smallest possible zone and properly be isolated from the rest of the HVDC system.
- c) Correct alarms shall be announced, sequence of event recorder and transient fault recorder should show that the sequence has taken place correctly.
- d) Safe isolation of a pole and/or converter shall be accomplished with and without telecommunication.
- e) The impact to the HVDC system and the connected a.c. systems shall be within specified performance criteria.

6.1.4 Power and current ramping

6.1.4.1 General

The test should demonstrate that the HVDC system power can be smoothly ramped up from minimum power to approximately 0,3 pu and then down, in both power and current control. The test should be conducted with telecommunication in service. However, if applicable, ramping should also be demonstrated with telecommunication out of service.

6.1.4.2 Purpose of test

Purposes of the test are the following:

- a) Verify the smooth ramping at different rates for each pole and for the bipole (if applicable).
- b) Verify the smooth transfer between operations with telecommunication in and out of service.
- c) Verify the smooth transfer between power and current control.

6.1.4.3 Test precondition

Test preconditions are the following:

- a) The HVDC system should have been energized and operated at minimum rated current.
- b) The protective blocking and tripping sequences should have been verified.
- c) The connected a.c. systems can deliver or accept the transmitted power without affecting their stable operation.

6.1.4.4 Test procedure

The ramping test shall be performed in monopolar metallic and earth return configuration for each pole and then, if applicable, in bipolar operation.

If possible, ramping test should also be tested with telecommunication out of service as follows.

- a) Having established voice communication, the converters are de-blocked individually by the operators of each terminal and current of the HVDC system reaches the stable status at the minimum rated value.
- b) After remaining at the minimum rated value for a short time, the current should be ramped to the next preselected level and reach the stable status again. This procedure should be repeated until the current has reached 0,3 pu.
- c) Throughout the test, check the valve cooling system and all current paths, especially the equipment inside the valve hall, the converter transformers, smoothing reactors and the wall bushings.
- d) Ramp down to minimum current and restore telecommunication.

- e) Repeat the above test in automatic control mode and joint control.
- f) Transfer to power control and repeat the test.

6.1.4.5 Test acceptance criteria

The test acceptance criteria are the following:

- a) Current and power of the HVDC system shall ramp smoothly for all applicable d.c. system configurations.
- b) At all times a.c. and d.c. currents and voltages shall be stable and remain within specified limits. The firing angle and the transformer tap changer shall operate correctly and shall be kept within specified limits.
- c) No hot spots shall occur at equipment in the a.c. and d.c. yard or in the valve hall.
- d) The valve cooling system shall maintain the valve temperature within specified limits.
- e) Transfer between current and power control or vice versa shall be smooth.
- f) If applicable, it should be verified that the control system schedules the necessary reactive power elements in the appropriate order to keep the a.c. voltage and reactive power interchange within the specified limits.

6.1.5 Tap changer control test

6.1.5.1 General

The test should demonstrate that the tap changer of the converter transformer can be changed up and down in both manual and automatic control mode.

6.1.5.2 Purpose of test

Purposes of the test are the following:

- a) Verify the tap changers of the converter transformer can be changed up and down in both manual and automatic control mode.
- b) Verify the tap changers of the converter transformer in different phases and different units (if applicable) can be changed synchronously.

6.1.5.3 Test precondition

Test preconditions are the following:

- a) The HVDC system should have been energized and operated at minimum rated current.
- b) The protective blocking and tripping sequences should have been verified.
- c) The connected a.c. systems can deliver or accept the transmitted power without affecting their stable operation.

6.1.5.4 Test procedure

The tap changer control test shall be performed either in monopolar metallic or earth return configuration for each pole.

- a) Having established voice communication, the converters are de-blocked individually by the operators of each terminal and current of the HVDC system reaches the stable status at the minimum rated value.
- b) After remaining at the minimum rated value for a short time, the current should be ramped to the next preselected level and reach the stable status again. This procedure should be repeated until the current has reached 0,3 pu.
- c) Throughout the test, check the valve cooling system and all current paths, especially the equipment inside the valve hall, the converter transformers, smoothing reactors and the wall bushings.

- d) Ramp down to minimum current.
- e) Repeat the above test in automatic control mode and joint control.
- f) Transfer to power control and repeat the test.
- g) Current and power of the HVDC system shall ramp smoothly for all applicable d.c. system configurations.
- h) At all times a.c. and d.c. currents and voltages shall be stable and remain within specified limits. The firing angle and the transformer tap changer shall operate correctly and shall be kept within specified limits.
- i) No hot spots shall occur at equipment in the a.c. and d.c. yard or in the valve hall.
- j) The valve cooling system shall maintain the valve temperature within specified limits.
- k) Transferring between current and power control and vice versa shall be smooth.

6.1.5.5 Test acceptance criteria

Tap changer works as expected/designed.

6.2 Operator control mode transfer

6.2.1 General

6.2.1.1 General features

6.2.1.1.1 Arrangement

Arrangement of the operator control mode transfer tests should be combined with other basic operation tests of different d.c. configurations and different operation statuses.

6.2.1.1.2 HVDC system condition

The operating conditions of the HVDC system may be:

- a) normal operation, which includes synchronous and islanded operation (if applicable);
- b) contingency operation, which can exist if a single failure occurs but the HVDC system can continue operation within specified limits. And loss of telecom represents a typical example;
- c) emergency operation (having the specific definitions in each project), which normally does not need to be tested in the actual system during commissioning. However it should be tested during off-site tests.

6.2.1.1.3 Control locations

Operator control actions can be initiated from various locations. The typical locations are:

- a) local control, which may be applied when the control functions can be initiated from the local control room at either converter terminal;
- b) remote control, which may be applied when the control functions can be initiated from a control centre remote from either converter terminal.

6.2.1.1.4 Control modes

The operator can accomplish a change of operational status by using one of two different control methods:

- a) Automatic control

In automatic control, the operator may initiate a change of operational status, a change of configuration or a change of power (current) reference selection, and the respective controls execute the correct order. The successful completion shall be verified by monitoring.

- b) Manual control

In manual control, the control of the converter terminal may be performed in discrete steps from one operational status to another. Compared to the automatic control mode, the operator may be offered a choice of additional intermediate steps and intervention in the control sequences. Completion of any control sequence shall be verified by monitoring.

6.2.1.1.5 Control levels

The HVDC system can be controlled in four different hierarchical control levels:

a) System control level (joint control available)

At the system control level the complete HVDC system can be controlled jointly from one of the remote or local operator control locations, hence telecommunication should be in service at this level.

b) Bipolar control level (joint or separate control available)

At the HVDC bipolar control level, the HVDC bipole is controlled jointly and power is distributed between the two poles. When telecommunication is not available, the power can be controlled by each station. The stations can be jointly controlled from one location when telecommunication is available.

c) Pole control level (joint or separate control available)

At the pole control level, each pole can be controlled separately when telecommunication is not available. The poles of both stations can be jointly controlled from one location when telecommunication is available.

d) Converter control level

At the converter control level, each converter can be controlled separately.

6.2.1.2 General precondition

The following tests and activities should have been completed before the basic operation tests proceed:

- a) off-site tests should have been completed;
- b) converter tests for each station should have been completed;
- c) when applicable back-to-back test or short circuit tests should have been completed, if possible;
- d) open line test of the HVDC transmission circuit should have been completed;
- e) earth electrodes and earth electrode lines should have been checked and cleared;
- f) telecommunication system and telephone system should be in service;
- g) the overall test procedures, safety rules, dispatch co-ordination and test responsibilities should have been established;
- h) fire protection and detection systems should have been checked and in service;
- i) all control protection, metering, sequence of events and fault recording systems should have been checked and in service.

6.2.1.3 General purpose

Operator control mode transfer tests verify the proper co-ordination and inter-station interlocking of the basic HVDC control and protection functions at different power levels. The tests should be performed with various a.c. and d.c. system configurations and in applicable fault status.

The tests should be compiled in such a way that all the control modes, control levels and control locations could be tested without unnecessary duplication.

6.2.2 Control location transfer

6.2.2.1 General

The normal operation control of a d.c. system can be performed either at remote or local station control centres. And the control location can be switched between them, which should be verified in the test. Moreover, the backup control function, which should be verified in the test, is configured on the control equipment, in case the fault of the operator control terminal leads to losing control of the HVDC transmission system.

The function of control location transfer between converter stations of both terminals should be tested at low power level and checked at high power level again, if applicable. Moreover, it should be combined with other tests.

The control function at the remote control centre should be tested after all the control function tests at converter station are completed.

6.2.2.2 Purpose of test

The purposes of the test are the following:

- a) to verify the control function at different control locations;
- b) to verify the performance of control location transfer.

6.2.2.3 Test precondition

Test preconditions are the following:

- a) The control location transfer tests should have been exercised off site.
- b) The basic operation tests should have been completed.
- c) Telecommunication system should be in service.

6.2.2.4 Test procedure

Test procedure is the following:

- a) Transfer the control location between converter stations, and verify the control functions.
The test should be conducted at low power level and can be combined with other test items.
- b) Transfer the control location to the control equipment, and verify the functions.
- c) Transfer the control location to the remote control centre, and verify the functions.

6.2.2.5 Test acceptance criteria

The test acceptance criteria are the following:

- a) Control location shall be transferred smoothly and correctly.
- b) The control functions at different locations shall be correct.
- c) Transfer between different locations shall not disturb the d.c. and the connected a.c. network.

6.2.3 Control function transfers

6.2.3.1 General

Different d.c. power control modes, which include pole current, pole power and bipolar power, should be chosen according to the different equipment conditions when HVDC power transmission is in operation. In addition, the tests should be arranged to verify how the fault of inter-station telecommunication affects the d.c. power control mode transfer.

Transfer tests of d.c. power control modes, including pole current, pole power, bipolar power, should be tested at low power level and checked at high power level again, if applicable.

6.2.3.2 Purpose of test

Verify the function and performance of d.c. power control modes, including pole current, pole power, and bipolar power.

6.2.3.3 Test precondition

Test preconditions are the following:

- a) The power control mode transfer tests should have been exercised off site.
- b) The basic operation tests should have been completed.
- c) Telecommunication system should be in service.

6.2.3.4 Test procedure

Test procedure is the following:

- a) On condition that the HVDC transmission is not in operation and with inter-station telecommunication in service, the operator transfers the d.c. power control mode subsequently from pole current to pole power, then to bipolar power and vice versa, at control centre of master station.
- b) With the inter-station telecommunication out of service, repeat the tests a) at each station independently.
- c) Start the HVDC transmission to minimum current, and repeat the test a) and b).
- d) At high power level, repeat test a) and b) again, if applicable..

6.2.3.5 Test acceptance criteria

Test acceptance criteria are the following:

- a) DC power control mode shall be transferred smoothly and correctly.
- b) The functions of different power control modes shall be correct.
- c) Transfer between different power control modes shall not disturb the d.c. and the connected a.c. network.

6.2.4 Reactive power control mode transfer

6.2.4.1 General

There are two reactive power control modes:

- a) AC voltage control mode

In a.c. voltage control mode, the voltage at the converter a.c. bus remains within specified limits during switching of the reactive power compensation elements.

- b) Reactive power control mode

In reactive power control mode, the exchanged reactive power between converter station and a.c. system remains within specified limits by switching of the reactive power compensation elements.

The reactive power control mode transfer tests should begin at low power level, and be performed at different power levels as well as at each station independently. Moreover, in the process, the tests should not be limited by the absolute minimal and minimal a.c. filter control functions.

6.2.4.2 Purpose of test

Verify the function of the reactive power control modes and the performance of transfer in-between them.

6.2.4.3 Test precondition

Test preconditions are the following:

- a) The reactive power control mode transfer should have been exercised off site.
- b) The basic operation tests should have been completed.
- c) The setting and parameters of the reactive power control mode should have been verified off site.
- d) The control location transfer test should have completed.
- e) Pole current, pole power and bipolar power control mode transfer tests should have been completed.
- f) Telecommunication system should be in service.

6.2.4.4 Test procedure

Test procedure is the following:

- a) Set the reactive power in manual control mode and d.c. power in power control mode.
- b) Start the HVDC transmission to minimum power.
- c) Set the reactive power setting with the required reactive power exchange and automatic control mode.
- d) Ramp the power up and verify the reactive power compensation elements switched with the increasing power, and vice versa.
- e) Change the reactive power setting of the exchanged reactive power control mode and verify the reactive power compensation elements switching with the increasing power, and vice versa.
- f) Change the voltage setting of the a.c. voltage control mode according to the a.c. converter bus voltage, and transfer to a.c. voltage control mode.
- g) Change the a.c. voltage setting in the a.c. voltage control mode and verify the reactive power compensation elements switching with the changed setting, and vice versa.
- h) Transfer to the reactive power manual control mode and verify the reactive power compensation elements by means of manually switching.
- i) Repeat the tests at higher transmission power level.
- j) Repeat the tests with d.c. power in current control mode.

6.2.4.5 Test acceptance criteria

Test acceptance criteria are the following:

- a) The reactive power control mode shall be transferred smoothly and correctly.
- b) The functions of different reactive power control modes shall be correct.
- c) Transfer between different reactive power control modes shall not disturb the d.c. and the connected a.c. network.

6.2.5 Rated to reduced voltage transfer

6.2.5.1 General

During adverse weather conditions or conditions of excessive contamination, manual or automatic reduction of the d.c. voltage may be required to reduce stresses on cables/lines

when the power transfer level is reduced, or to minimize the possibility of flashover at overhead d.c. lines.

6.2.5.2 Purpose of test

Verify the function of the rated and reduced voltage operation mode and the performance of transfer between them.

6.2.5.3 Test precondition

The test preconditions are the following:

- a) Reduced voltage operation should have been tested off-site.
- b) The basic operation tests should have been completed.
- c) The telecommunication should be in service.

6.2.5.4 Test procedure

Test procedure is the following:

Reduced voltage operation shall be tested in all a.c. and d.c. system configurations.

- a) Start the HVDC transmission to minimum current with rated voltage.
- b) Transfer to reduced voltage operation and maintain steady state for one hour.
- c) Transfer back to rated voltage operation.
- d) Transfer to reduced voltage operation by both manual and automatic means (e.g. after d.c. line faults).
- e) Repeat the test at a high current level.
- f) Repeat the test in power control.

6.2.5.5 Test acceptance criteria

Test acceptance criteria are the following:

- a) Operation with reduced voltage shall be stable.
- b) Transfer to and from reduced voltage operation shall take place smoothly and correctly.
- c) Transfer to and from reduced voltage operation shall not disturb the connected a.c. network.
- d) The control system functions shall be correct for all current levels.
- e) The performance of valve cooling system should be adequate for all current levels.

6.2.6 DC power automatic control

6.2.6.1 General

The d.c. power load profile control is set according to the plan of d.c. power supply in specific period (day, week or month). In the d.c. power automatic control mode, the d.c. power will change with the preset power load profile control, and is monitored.

The function of the d.c. power automatic control shall be tested at the pole of bipolar power control mode and different a.c./d.c. system configurations.

6.2.6.2 Purpose of test

Verify the function and the performance of d.c. power automatic control.

6.2.6.3 Test precondition

Test preconditions are the following:

- a) DC power automatic control should have been tested off-site.
- b) The basic operation tests should have been completed.
- c) Pole current, pole power and bipolar power control mode transfer tests should have been completed.
- d) Telecommunication system should be in service.

6.2.6.4 Test procedure

Test procedure is the following:

- a) Set both pole in bipolar power and power manual control mode.
- b) Start the HVDC transmission to minimum power.
- c) Enable the d.c. power automatic control function, and observe the d.c. power transmission according to the preset automatic curve (at least three changing points).
- d) Repeat the test with one pole in bipolar power and the other in power control mode.
- e) Repeat the test at other a.c. and d.c. configurations.

6.2.6.5 Test acceptance criteria

Test acceptance criteria are the following:

- a) Automatic and manual d.c. power control mode shall be transferred smoothly and correctly.
- b) The d.c. power shall change according to the preset automatic curve and operation shall be stable.

6.3 Changes of d.c. configuration

6.3.1 General

6.3.1.1 General features

Most HVDC long distance transmission schemes can be operated in several d.c. configurations such as monopolar earth return, monopolar metallic return, bipolar normal and in parallel operation. Each of these configurations can contain one or more d.c. filters.

If series connected converter units per pole are used, switching of these groups should be demonstrated. The polarity reversal of the HVDC system should be verified, if available. Operations involving both terminals should be performed with or without telecommunication.

Back-to-back station needs no change of d.c. configuration.

The purpose of tests, preconditions and test procedures are similar to that of the items under 6.3.1 through 6.3.3.

Regarding denomination of switches and their function, refer to 4.5 of IEC/TR 60919-2:2008.

6.3.1.2 Purpose of test

Verify coordinated switching between converter terminals and for d.c. bus reconfiguration and thus prevent switching from conditions which can cause severe stresses on the d.c. equipment.

6.3.1.3 Test precondition

Test preconditions are the following:

- a) All sequences should have been checked on the non-energized system.
- b) All energizing tests of a.c. and d.c. equipment should have been completed.
- c) Basic operation tests should have been completed.

6.3.1.4 Test procedure

The procedure should be conducted according to the configuration of the main circuit of the project, and the following shows an example of the standard common scheme.

- a) During all tests, a.c. and d.c. voltages and currents should be recorded. Outdoor observations of abnormal sounds and arcings should be made.
- b) The timing of the various switching sequences should be verified. All switching sequences should be performed step by step, and be executed automatically if applicable. If both terminals are involved telecommunication should be in service.
- c) Where appropriate, additional tests may be performed at lower than nominal power and at minimum power.

6.3.1.5 Test acceptance criteria

Test acceptance criteria are the following:

- c) The HVDC transmission shall not be permanently disrupted by any change of d.c. configuration.
- d) Currents and voltages should coincide with the results of corresponding simulator tests and be in accordance with the specification.

6.3.2 Tests from monopolar metallic return operation

6.3.2.1 Transfer type

From this configuration, the following changes can be made:

- a) transfer to monopolar earth return;
- b) transfer to bipolar configuration;
- c) paralleling and de-paralleling of another pole.

6.3.2.2 Transfer procedure

6.3.2.2.1 Monopolar earth return

Transfer procedure is the following:

- a) Operate at nominal power.
- b) Close the MRTB (metallic return transfer breaker).
- c) Open the ERTB (earth return transfer breaker).

6.3.2.2.2 Bipolar operation

Transfer procedure is the following:

- a) Operate at nominal power.
- b) Close the MRTB.
- c) Open the ERTB.
- d) Verify the current balance in both poles.

6.3.2.2.3 Paralleling and de-paralleling

Transfer procedure is the following:

- a) Operate one pole at nominal power.
- b) Close paralleling disconnector of the non-operating pole.
- c) De-block the non-operating pole.
- d) Verify the current balance in both poles.

6.3.3 Tests from monopolar earth return mode

6.3.3.1 Transfer type

Monopolar earth return may not be recommended for a long period of time for some projects. From this configuration, the following changes can be made:

- a) transfer to monopolar metallic return;
- b) transfer to bipolar operation.

6.3.3.2 Transfer procedure

6.3.3.2.1 Transfer to monopolar metallic return

- a) Transfer procedure is the following: Operate at nominal power.
- b) Close the ERTB.
- c) Open the MRTB.

6.3.3.2.2 Transfer to bipolar operation

- a) Operate at nominal power.
- b) Close the line pole disconnector of the non-operating pole.
- c) De-block the non-operating pole.
- d) Verify the current balance in both poles.

6.3.4 Tests from bipolar operation

6.3.4.1 Transfer type

From this specific configuration, the following changes can be made:

- a) monopolar earth return;
- b) monopolar metallic return.

6.3.4.2 Transfer procedure

6.3.4.2.1 Monopolar earth return

Transfer procedure is the following:

- a) Operate up to maximum specified monopolar power.
- b) Reduce the current in one pole to a minimum but keep the bipolar power constant.
- c) Block the pole with minimum power.
- d) Open the line pole disconnector of the blocked pole.

6.3.4.2.2 Monopolar metallic return

Transfer procedure is the following:

- a) Operate up to maximum specified power.
- b) Reduce the current in one pole to a minimum but keep the bipolar power constant.
- c) Block the pole with minimum power.

- d) Open the line pole disconnecter of the blocked pole.
- e) Close the ERTB.
- f) Open the MRTB.

6.4 Main circuit equipment switching

6.4.1 General

6.4.1.1 General features

The main circuit equipment switching tests verify the transient behaviour of the a.c. and HVDC systems during and after switching. Previous tests, including converter station tests and basic operation tests have verified that the functions of the d.c. equipment are correctly. The tests described are only for two-terminal and back-to-back HVDC systems.

Regarding denomination of switches and their function, refer to IEC/TR 60919-2:2008.

Primary equipment switch tests may include the tests that would verify proper interaction and coordination between the HVDC system under test and such other on-line equipment as static VAR compensators, other HVDC systems, etc.

6.4.1.2 General precondition

6.4.1.2.1 Off-site tests including a.c./d.c. simulator tests should have been completed.

6.4.1.2.2 Single-terminal tests including converter unit tests and converter station tests should have been completed.

6.4.1.2.3 Basic operation tests to verify sequences and inter-station coordination should have been completed.

6.4.1.2.4 Steady state operation should have been completed, including verification of steady state performance and interference effects.

6.4.1.2.5 Detailed procedures and plans should be prepared. As the tests may involve some disturbance or increased risk to the connected a.c. systems, the operators of the related systems should be consulted.

6.4.1.2.6 The connected a.c. systems should be within their specified limits, and can deliver the active and reactive power for the HVDC system required for the particular test. The important parameters include:

- a) a.c. voltage and frequency;
- b) short circuit capacity;
- c) a.c. system configuration.

6.4.1.3 General object

The primary equipment switch tests verify the effects of switching and connection of a.c. side equipment and d.c. filters.

6.4.2 Switching converter transformer

6.4.2.1 General

The switching of the converter transformers on the other pole can create disturbances to the a.c. system. These disturbances are due to inrush current, saturation of components as well as resonance conditions.

6.4.2.2 Purpose of test

The purposes of the test are as follows:

- a) to verify that switching will not have any adverse effect on the operation of the d.c. system;
- b) to verify that a.c. system voltage disturbances are within the prescribed limits;
- c) to verify the proper recovery from commutation failures, if appropriate;
- d) to verify that the HVDC control system should perform without instability during such conditions;
- e) to verify the performance of the HVDC control system in cases it is used to produce a damping effect to such disturbances.

6.4.2.3 Test precondition

Test preconditions are the following:

- a) All control performance tests should have been performed.
- b) The commutation failure protection should be functional.
- c) All a.c. and d.c. equipment for the pole tested should be available.

6.4.2.4 Test procedure

The tests should vary with the HVDC system configuration, for example:

- bipolar or monopolar systems;
- converter units in series or single converter unit per pole (long distance transmission);
- back to back systems.

If the d.c. system is bipolar and with a single group per pole whether back-to-back or long distance, then the test should be performed by switching on and off the converter transformer in one pole while the other pole is in operation. This means that the test can be performed only in monopolar operation, unless there is a transformer bank on site or close to the d.c. terminal of comparable rating that can be switched on and off after suitable time intervals.

If the d.c. system is bipolar with more than one valve group in series per pole (long distance transmission), the test should be performed by switching on and off one converter transformer while the system is in bipolar operation, provided that the plant design permits unbalanced numbers of groups per pole.

The tests should be performed at both the rectifier and inverter stations.

The monitoring includes:

- a) d.c. current;
- b) d.c. voltage;
- c) d.c. power;
- d) a.c. system voltage - 3 phases;
- e) a.c. filter currents;
- f) transformer primary currents;
- g) extinction angle.

6.4.2.5 Test acceptance criteria

Test acceptance criteria are the following:

- a) In all the switching tests, the HVDC system shall recover to stable operation.

- b) Commutation failure may occur during the test, but shall remain within the specified limits.
- c) AC system overvoltage may occur but shall remain within the specified limits.

6.4.3 Switching a.c. filters and reactive power compensation

6.4.3.1 General

The switching of the reactive power compensation devices can create disturbances to the a.c. system, which are due to inrush current, saturation of components as well as resonance conditions.

6.4.3.2 Purpose of test

Purposes of the test are the following:

- a) To verify that switching will not have any adverse effect on the operation of the d.c. system.
- b) To verify that a.c. system voltage disturbances are within the prescribed limits.
- c) To verify the proper recovery from commutation failures, if appropriate.
- d) To verify that the HVDC control system should operate without instability during such conditions.
- e) To verify the performance of the HVDC control system in cases where it is used to produce a damping effect to such disturbances.

6.4.3.3 Test precondition

Test preconditions are the following:

- a) All control performance tests should have been performed.
- b) The commutation failure protection should be in service.
- c) All a.c. and d.c. equipment of the pole under test should be available.

6.4.3.4 Test procedure

The switching test should be performed for each a.c. filter bank normally on monopolar operation. In some systems where redundant a.c. filters are available, this test can be performed in bipolar operation.

The tests should be performed at both the rectifier and inverter stations.

The monitoring includes:

- a) d.c. current;
- b) d.c. voltage;
- c) d.c. power;
- d) a.c. system voltage - 3 phases;
- e) a.c. filter currents;
- f) transformer primary currents;
- g) extinction angle.

6.4.3.5 Test acceptance criteria

Test acceptance criteria are the following:

- a) The HVDC system shall recover to stable operation in all the switching tests.
- b) Commutation failures may occur during the test, but shall remain within the specified limits.
- c) AC system over voltages may occur but shall remain within the specified limits.

6.4.4 Switching d.c. filter (if applicable)

6.4.4.1 General

Different d.c. configurations, such as monopolar earth return, monopolar metallic return, and bipolar normal and in parallel operation, can contain one or more d.c. filters.

6.4.4.2 Purpose of test

Purposes of the test are the following:

- a) Verify the function of d.c. filter switching.
- b) Verify the performance switching of d.c. filters.

6.4.4.3 Test precondition

Test preconditions are the following:

- a) All sequences of d.c. filter switching should have been checked on the non-energized system.
- b) All energizing tests of a.c. and d.c. equipment should have been completed.
- c) Basic operation tests should have been completed.

6.4.4.4 Test procedure

6.4.4.4.1 During all tests, a.c. and d.c. voltages and currents should be recorded. Outdoor observations of sounds and light phenomena should be made.

6.4.4.4.2 The timing of the various switching sequences should be verified. All switching sequences should be performed step by step. If applicable, the sequences should also be executed automatically.

6.4.4.4.3 Connection and disconnection of d.c. filters (if permitted) from monopolar metallic return operation should be performed as follows:

- a) record the d.c. filter harmonic current if and when possible;
- b) operate at nominal power and disconnect one d.c. filter;
- c) connect the d.c. filter again;
- d) repeat the procedure for all d.c. filters.

6.4.4.4.4 Connection and disconnection of d.c. filters (if permitted) from bipolar operation should be performed as follows:

- a) Record the d.c. filter harmonic current if and when possible.
- b) Operate at nominal power and disconnect one d.c. filter.
- c) Connect the d.c. filter again.
- d) Repeat the procedure for all d.c. filters.

6.4.4.5 Test acceptance criteria

Test acceptance criteria are the following:

- a) The HVDC transmission shall not be permanently disrupted by any d.c. filter switching.
- b) Currents and voltages shall coincide with the results from corresponding simulator tests and be in accordance with the specification.
- c) Rating of remaining filters shall not be exceeded.
- d) No burn marks shall occur on the disconnectors.

e) No adverse transient effects shall occur.

6.5 Dynamic performance testing

6.5.1 General

6.5.1.1 General features

In HVDC systems, various control loops are utilized. The dynamic performance studies of the control system should be confirmed through the following tests:

- a) step response;
- b) control mode transfer;
- c) commutation failure;
- d) a.c. system interaction / control.

It is recognised that dynamic performance verification is made through detailed simulator studies and the site test can only be taken as indicative for a particular scenario. The user must specify whether such test is required to be performed at site.

6.5.1.2 General purpose of test

Purposes of the test are the following:

- a) To confirm the response of each control loop following a change in the reference value.
- b) To verify the control behaviour during disturbances causing changes in the actual measured quantities (d.c. current, d.c. voltage etc.) of the respective control loop.
- c) To verify that the controllers will not interfere with each other or cause disturbances to the a.c. and/or d.c. systems.
- d) To verify the insensitivity of controllers to a.c. system disturbances.

6.5.1.3 General precondition

Test preconditions are the following:

- a) Off-site test of the control system should have been completed.
- b) Converter unit tests should have been completed.
- c) Start/stop sequences should have been checked.
- d) Protection sequences should have been checked
- e) Telecommunication should have been in service.
- f) All the equipment from the d.c. system necessary for power transmission of one pole should be available.
- g) The a.c. systems should be set up as close as possible to the minimum design effective short circuit ratio.

6.5.1.4 General test procedure

All tests for optimization and verification of the control performance should utilize a similar recording and monitoring set-up. The general monitoring and recording set-ups are listed below. The control performance tests that have been performed during the off-site tests can be used as a reference for on-site tests. The same recording equipment, monitored signals and test report sheets should be used as those used during the off-site tests.

The monitored variables should include:

- a) current order (at the current controller input);
- b) actual d.c. current (at the current controller);

- c) output of current controller;
- d) d.c. voltage;
- e) extinction angle at the extinction angle controller;
- f) final control voltage to firing controls (alpha order);
- g) identification of active controller;
- h) a.c. busbar voltage (3 phases);
- i) d.c. power;
- j) force retard command;
- k) stabilizing (damping) control signals (if any).

6.5.2 Step response

6.5.2.1 General

The tests depend on the various control modes in the HVDC system.

There are different modes of operation for each terminal of an HVDC system. The most common ones are:

- constant current control;
- constant minimum extinction angle control;
- constant d.c. voltage control ;
- current error control;
- constant power control.

Some of these control modes are only valid for operation as a rectifier or an inverter.

Based on the large variety of possible HVDC system controls, it is difficult to design one test to cover all possible control scenarios. Thus the tests should be described for the most common control loops.

In the case of the rectifier in constant current control and the inverter in constant minimum extinction angle control, the controllers that should be optimized are:

- a) rectifier current controller;
- b) inverter extinction angle controller;
- c) inverter current controller (margin current control);
- d) rectifier extinction angle controller;
- e) constant power controller;
- f) voltage dependant current order limiter (VDCOL).

6.5.2.2 Purpose of test

Confirm the behaviour/response of the controller.

6.5.2.3 Test precondition

Test preconditions are the following:

- a) The off-site control system tests should have been completed.
- b) Converter unit tests should have been completed.
- c) Start/stop sequences tests should have been completed.
- d) Protection sequences tests should have been completed.

e) Telecommunication system should be in service.

6.5.2.4 Test procedure

6.5.2.4.1 General

Step response tests should be performed at all controllers from that of the converter level to that of the station and system level.

6.5.2.4.2 Rectifier current controller

Several methods can be used to confirm the current controller at the rectifier. The typical one is to apply a step change (described as Figure 6) in the current order, which is described as follows.

- The duration of the applied step (T) should be long enough to allow the system to stabilize following the change in current order.
- The chosen current order (I_0) level prior to the step change should ensure that during the application of a step up in current order (ΔI) no limits are encountered.
- The location of application of the current order step should be as close as possible to the input of the current controller.
- During the test, the rectifier shall always be in d.c. current control and the current controller at the inverter should be prevented from interfering.

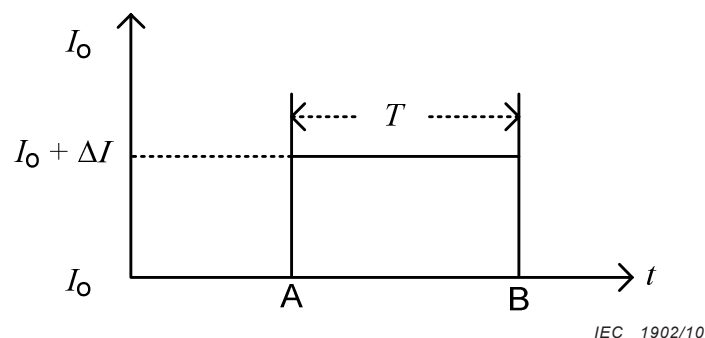

Figure 6 – Step response test of current control at the rectifier

6.5.2.4.3 Inverter extinction angle controller

In order to optimize this controller at the inverter, the rectifier will be in its normal mode of control and the inverter should be in the minimum constant extinction angle control.

A step change in the extinction angle reference at the controller should be applied (Figure 7), which is described as follows.

- The first step change (A) should be applied only in the direction of increasing the reference to avoid commutation failures.
- The chosen extinction angle order (γ_0) level prior to the step change should ensure that during the application of a step up in extinction angle order ($\Delta\gamma$) no limits are encountered.
- After optimization of the controller parameters a second step change (B) from $\gamma_0 + \Delta\gamma$ back to γ_0 should be applied.
- If the controller has other inputs which affect the extinction angle, the test should also be repeated for these inputs. For example if an input increases the extinction angle due to a sudden increase in d.c. current or a sudden decrease in the a.c. voltage, these functions should be checked following the optimization with step changes in the extinction angle.

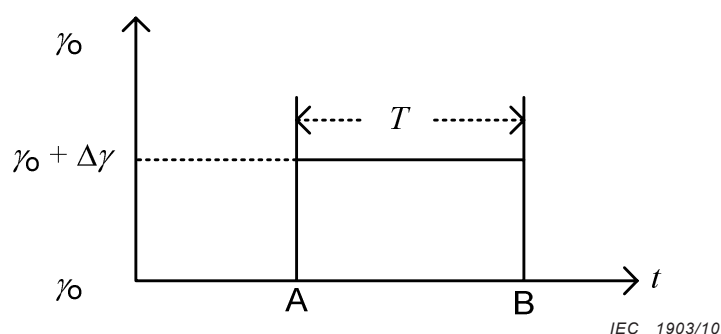

Figure 7 – Step response test of extinction angle control at the inverter

6.5.2.4.4 Inverter voltage controller (if available)

In order to optimize this controller at the inverter, the rectifier will be in its normal control mode and the inverter should be in the voltage control.

A step change in the d.c. voltage reference at the controller should be applied, which is described as follows.

- a) The first step change (A) should be applied only in the direction of decreasing the reference to avoid commutation failures.
- b) The chosen d.c. voltage order (Vd_0) level prior to the step change should ensure that during the application of a step up in d.c. voltage order (ΔVd) no limits are encountered.
- c) After optimization of the controller parameters a second step change (B) from $Vd_0 + \Delta Vd$ back to Vd_0 should be applied.

If the controller has other inputs, which affect the d.c. voltage, the test should also be repeated for these inputs.

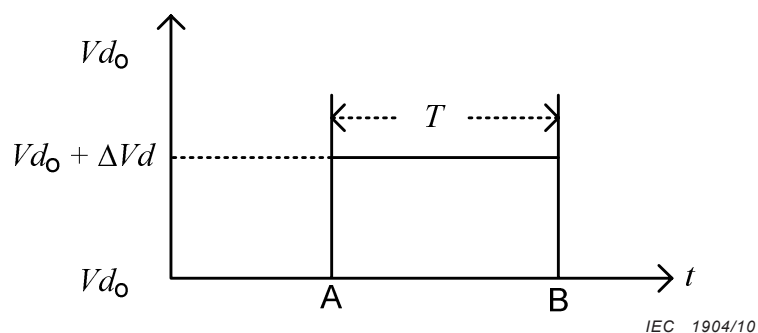

Figure 8 – Step response test of d.c. voltage control at the inverter

6.5.2.4.5 Inverter current controller (current margin controller)

During this test, the rectifier should be in constant firing angle control (α_{min}) and the inverter is in constant current mode of operation. A step change in the current order (described in Figure 9) at the input of the inverter current controller is applied. The duration of the step (T) is long enough to achieve stable operation following its application, which is described as follows.

- a) The chosen current order (I_0) level prior to the step change should ensure that no limits are encountered during the application of a step up in current order (ΔI).

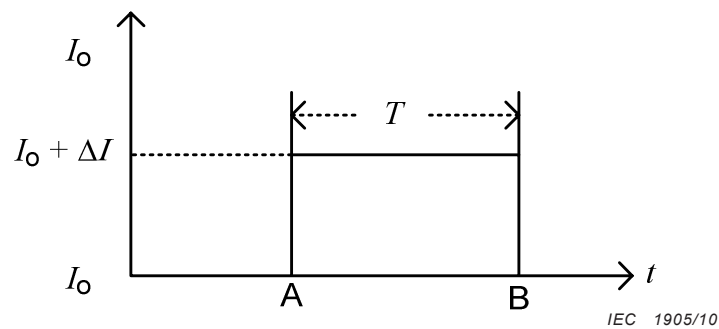

Figure 9 – Step response test of current control at the inverter

6.5.2.5 Rectifier extinction angle controller

In order to fine tune the extinction angle controller at the rectifier, two situations can be considered.

- In the case of a transmission system in which the direction of power is always constant, specifically that one terminal is always a rectifier and the other is always an inverter. The function of this controller will be limited to the situation when force retard is applied. The response of the controller should be checked during the application of force retard.
- In the case of an HVDC system in which power reversal is used, the optimization of the controller at the second terminal should be performed during transmission in the reverse power direction.

6.5.2.6 Constant power controller

In order to optimize this controller a step change in the power order (ΔP) is applied (Figure 10), which is described as follows.

- The duration of the applied step (T) should be long enough to allow stable operation to be achieved.
- The chosen power order (P_o) level prior to the step change should ensure that during the application of a step up in power order (ΔP) no limits are encountered.
- The chosen step size of ΔP should ensure that the change in current order exceeds the current margin.
- Additional tests with smaller ΔP may be conducted to check for instability and interaction with other control loops.

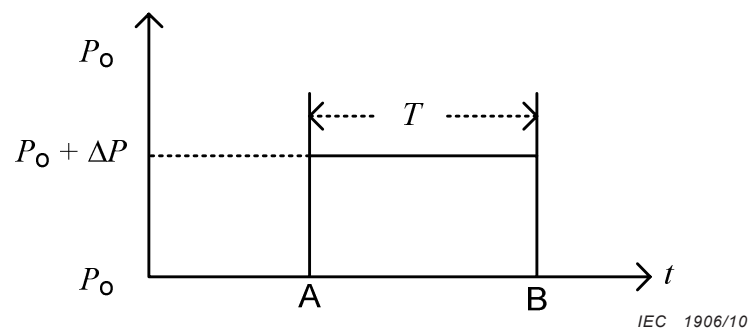

Figure 10 – Step response test of power control at the rectifier

6.5.2.7 Test acceptance criteria

Test acceptance criteria are as follows:

- a) Controller's performance is stable and satisfactory.
- b) All control system parameters shall be similar to those obtained during the off-site tests. If there are deviations between the real d.c. system and the off-site tests, they should be explained.
- c) Optimization shall ensure that the response of the d.c. system to the step change is the least amount of overshoot and the shortest settling time.
- d) No instability shall occur during the step response tests.

6.5.3 Control mode transfer

6.5.3.1 General

The basic control mode transfer (see 7.2) can be divided into two general types:

- a) from constant power control mode to constant current control mode and back at the converter;
- b) from constant extinction angle control mode or constant d.c. voltage control mode to constant current control mode and back at the inverter.

If some additional control modes are applied for special applications, the control mode transfer should be tested with respect to the particular application. The test criteria, however, should be similar as what have been discussed here.

HVDC systems are typically operated in constant power order control mode.

Under certain conditions, the control mode shall be transferred from constant power control mode to constant current one. At the pole control level, it is a typical configuration to operate the rectifier in constant current control and the inverter in constant extinction angle control.

It is common that the inverter is also equipped with a constant current controller. During certain a.c. system conditions, a transfer from constant extinction angle control mode to constant current control mode and back will be required at the inverter.

6.5.3.2 Purpose of test

Verify the function of different control modes and the performance of transfer between them.

6.5.3.3 Test precondition

Test preconditions are as follows:

- a) The off-site control system tests should have been completed.
- b) Converter unit tests should have been completed.
- c) Start/stop sequences tests should have been completed.
- d) Protection sequences tests should have been completed.
- e) Telecommunication system should be in service.
- f) The step response tests should have been completed and the individual controllers should have been optimized.

6.5.3.4 Test procedure

6.5.3.4.1 For d.c. systems where the transfer from constant power order control mode to constant current order control mode is a manual function, the procedure shall be:

- a) start d.c. system in constant power order control mode and operate in a stable level;
- b) change the current reference according to the actual d.c. current and transfer to constant current order control mode. The change of the current reference can be performed manually or automatically.

6.5.3.4.2 In some cases, during any decline in the a.c. bus voltage, in order to avoid power/voltage instability, the transfer from constant power order control mode to constant current order control mode can be activated automatically. The control mode transfer should be checked, by simulating a.c. under voltage or during a.c. system faults.

6.5.3.4.3 The control mode transfer from constant extinction angle control to constant current control at the inverter can be checked by operating the rectifier at its minimum firing angle and forcing the inverter into current control mode. It can be tested through the use of tap changer operations. Moreover, this test should be performed in constant current order control mode or in constant power order control mode.

6.5.3.5 Test acceptance criteria

Test acceptance criteria are the following:

- a) The control mode transfer shall be smooth with stable operation during and after the transfer from constant power control to constant current control and back.
- b) Step changes in power shall not occur during the control mode transfer.
- c) The control mode transfer from constant extinction angle control to constant current control at the inverter shall be stable.

6.5.4 Commutation failures

6.5.4.1 General

Commutation failures on a d.c. system can be caused by either:

- a) a.c. system disturbances;
- b) converter control malfunctions.

Commutation failures may occur only once (single commutation failure), or during a number of consecutive periods (multiple commutation failure), or may be persistent (persistent commutation failure). Commutation failures by converter control malfunction should be simulated during the tests described in this part. Trial operation provides a useful further test with regard to normal system disturbances (rather than those simulated).

6.5.4.2 Purpose of test

Purposes of the test are the following:

- a) To verify that the control system is stable during and after commutation failures and valve misfires, and that recovery is achieved within the prescribed time period.
- b) In the case of a d.c. system where the d.c. power circuit is resonant at a frequency close to the fundamental, the commutation failures may excite oscillations on the d.c. side. The tests should verify that the control system can damp such oscillation upon the removal of the excitation. In addition, the tests should verify that these oscillations do not be magnified due to the action of the control system.
- c) To check the commutation failure protection and any valve overload protection such as voltage dependent current limits.
- d) Verify that the d.c. line or cable protection do not operate during these disturbances in the case of HVDC systems with overhead lines or cables.

6.5.4.3 Test precondition

Test preconditions are the following:

- a) The optimization of the control system shall be completed.
- b) All equipment from the d.c. system for one pole necessary for power transmission shall be available.
- c) In the case of long distance transmission, the d.c. line or cable protection should be with its final settings.
- d) The telecommunications should be available in the case of long distance transmission.
- e) The inverter a.c. system should be set up as close as possible to the minimum design effective short circuit ratio.

6.5.4.4 Test procedure

6.5.4.4.1 The tests described for one direction of power flow should be repeated if the system is designed for power reversal.

6.5.4.4.2 The tests may be carried out at several current levels up to rated current.

6.5.4.4.3 In the case of long distance transmission and series connected groups per pole, the tests should be performed for all groups in operation and, if permitted by the plant design, also with reduced numbers of groups.

6.5.4.4.4 In addition to the monitoring points listed in the general section of Subclause 7.5, the following signals should be monitored during the tests:

- a) the measured firing angle;
- b) the firing pulses to the valves.

However, these monitoring points may vary from one system to another.

6.5.4.4.5 The valve commutation failure in inverter operation or a firing failure in rectifier operation will be achieved by blocking the firing pulses to one valve. The location of blocking the pulse should be considered carefully, depending on the particular valve design, because the block of one firing pulse in the control system may initiate certain actions in the control and protection, which may create abnormal situations.

6.5.4.4.6 The duration of the applied commutation failure or firing failure respectively shall be increased in steps:

- a) duration shorter than the time required to initiate any protective action;
- b) duration long enough to activate any valve overload protection such as voltage dependent current limiting;
- c) duration long enough to initiate the persistent commutation failure or firing failure protection (tripping of the converter).

In the case of long distance transmission, the test should be performed with and without telecommunications.

6.5.4.5 Test acceptance criteria

The test criteria depend on the duration of the commutation failure and the respective station of the selective protection system.

- a) No protection system shall be initiated. The controls shall perform reliably and recover within the specified time. Any oscillations shall be damped.

- b) Valve overload protection shall be initiated. The d.c. current shall be reduced by control action and the system shall recover following the end of the commutation failures.
- c) The persistent commutation failure protection shall be initiated. The designed sequence of tripping the converter shall be correct. DC system and a.c. system components shall not be affected.

6.5.5 AC system interaction / control

6.5.5.1 General

The controllability of HVDC systems is an important advantage of this technology. Additional d.c. controls also make it possible to operate HVDC systems with weak a.c. systems. This feature can be valuable in improving the dynamic performance of large a.c. systems.

To achieve these advantages, the control systems should perform appropriately for various disturbances and system conditions. The control loops should not interact unfavourably with each other.

To obtain adequate control performance, operation at higher than nominal rectifier firing angles or higher than minimum inverter extinction angles may be required.

Commonly, the specified a.c. system interaction/control functions are:

- a) frequency control;
- b) reactive power regulation;
- c) a.c. voltage control;
- d) temporary overvoltage control;
- e) damping of frequency or power oscillations;
- f) frequency or power dependent power changes (so-called runbacks);
- g) sub-synchronous resonance control(SSR);
- h) special controls during faults.

6.5.5.2 Purpose of test

The object is to confirm the simulation results.

6.5.5.3 Test precondition

Test preconditions are the following:

- a) Off-site test of the control system should have been completed.
- b) Converter unit tests should have been completed.
- c) Start/stop sequences should have been checked.
- d) Protection sequences should have been checked.
- e) Communication system should be in service.
- f) The step response tests should have been completed and the individual control loops should have been optimized.
- g) The control mode transfer tests should have been completed.
- h) The a.c. system should be set-up in a condition which refers to the specific a.c. system interaction/controller.

6.5.5.4 Test procedure

The test procedures for the a.c. system interaction controllers may differ for the individual application and functions.

The control settings should be obtained from off site tests on the simulator and be fine tuned on the real HVDC system.

Test the control behaviour during disturbances should be planned very carefully. The execution involves the connected a.c. system and can have a serious impact on it.

In order to check the interaction of the HVDC system with the a.c. system, a.c. system disturbances or HVDC operating mode changes may be initiated by:

- a) power modulation;
- b) load rejection (simulated d.c. line faults);
- c) a.c. line switching;
- d) generator tripping;
- e) ramping of d.c. power;
- f) power reversal;
- g) transformer energizing;
- h) filter switching;
- i) a.c. or d.c. line faults;
- j) modulation of generator excitation system.

Some of the above mentioned initiating functions are also dealt with in Subclauses 6.4, 6.5 and 6.6.

6.5.5.5 Test acceptance criteria

Test acceptance criteria are the following:

- a) The objective is to confirm the simulation results.
- b) All control system parameters shall be similar to those obtained during the off-site tests. Deviations between the results from site tests and the results from off-site tests can occur, but should be explained.
- c) No instability shall occur during the a.c. interaction/control tests.

6.6 AC and d.c. system staged faults

6.6.1 General

6.6.1.1 AC network faults

The response of an HVDC system to a.c. network faults in the connected a.c. networks should be known precisely so that appropriate control actions can be confirmed. Modern digital study and simulation tools or HVDC simulators can also be utilized to simulate staged fault tests. In such cases, some items should be verified including the proper function and coordination of the control and protection equipment, the stress on all components in the a.c. and d.c. system not exceeding their permissible limits. Normally, to maintain stability, the d.c. power flow should be re-established without undue delay when commutating voltages reappear after fault clearance. Due to inrush currents, the voltages may be severely distorted. This may complicate the tasks of the control system and circulate unconventional current waveforms in the protection relays of the a.c. system with the associated risk of spurious protection operation.

The staged fault tests, which can verify the a.c. and d.c. system protection on the real project, may require the arrangement of particular system conditions which may expose the affected equipment to high stress and effect equipment life time.

Transient faults on the d.c. line are normally cleared by the combined action of protection and converter control, which extinguishes the arc by temporary blocking, or by force retarding the rectifier.

In case of permanent fault on the d.c. side, depending on the design of the d.c. line, an automatic sequence should localize the faulted section, isolate it and re-establish if possible the initial power flow as rapidly as possible. Consequences of d.c. system faults on the a.c. systems are generally less severe than those due to a.c. system faults.

6.6.1.2 Purpose of test

Purposes of the test are the following:

- a) To verify the ability of the combined a.c./d.c. system to react as specified during and immediately after fault clearance.
- b) To verify that the converters continue to operate without commutation failure or with a specified maximum number of commutation failures in case of distant a.c. system faults.
- c) To verify that the d.c. power flow is re-established within a specified time after fault clearance in case of close faults.
- d) To verify that the rated d.c. power, if possible (depending on the HVDC design), should be re-established within specified time after clearance of the fault in case of d.c. side faults.

6.6.1.3 Test precondition

Test preconditions are the following:

- a) All a.c. and d.c. equipment should have been energized.
- b) Basic operation tests should have been completed.
- c) Changes of d.c. configuration (see 6.3) should have been checked.
- d) Response of protection relays in the a.c. system should have been checked with distorted waveforms.
- e) Control and protection performance should have been tested (see 6.5).
- f) Switching of the primary equipment (see 6.4) should have been checked.

6.6.1.4 Test procedure

6.6.1.4.1 Pre-fault condition

For any type of staged fault the following pre-fault system conditions should be specified and post-fault conditions should be estimated:

- a) telecommunication being in or out of service;
- b) frequency of the a.c. systems (in case of an isolated system);
- c) a.c. system voltage before and after the fault;
- d) configuration of the a.c. system where staged faults are applied, before and after the fault (lines in service to the nearest substations, close-by generating units, loads, and so on);
- e) short-circuit level on each side of the d.c. link;
- f) initial d.c. power flow;
- g) HVDC system configuration including a.c. and d.c. filters;
- h) expected time duration of the fault;
- i) location of the fault.

6.6.1.4.2 AC system configuration

DC staged faults normally do not require special a.c. system configurations. However, to maintain an acceptable level of system security during an a.c. staged fault test due to risk of misoperation of some protection relays or breakers, a special configuration of the a.c. system should be generally adopted with a very specific plan of generation.

6.6.1.4.3 Signal monitoring

Many signals should be monitored because this type of test cannot be repeated many times because of its cost, the stresses on the equipment and safety reasons. For the staged fault tests, the redundant recorders should be utilized.

6.6.1.4.4 Signal recording

The following signals shall be recorded:

On the system side:

- a.c. voltages and currents on each phase;
- d.c. voltages on both poles;
- a.c. currents in the converter feeders on each phase;
- d.c. currents on each pole and on each d.c. neutral connection;
- a.c. currents in filter banks.

On the controls system:

- main sequencing signals (start-stop, blocking-deblocking, breaker opening and closing orders);
- essential protection signals (e.g. overvoltage protection, commutation failure protection);
- firing angle order;
- firing pulses on each 12 pulse converter unit;
- alpha and gamma angle measurements;
- current order.

Some extra signals(if necessary):

- one valve voltage on each converter unit (that may require specific dividers to be provided);
- timing signal allowing synchronization between recordings in the converter stations and possibly in some generating stations in the vicinity.

For a.c. faults:

- some signals on the remote terminal, such as d.c. voltage and current, current order, and firing angle order.

6.6.1.4.5 HVDC power level

The HVDC power level adopted depends on the a.c. system configuration prepared for the test with its associated generation plan.

6.6.1.4.6 Safety

Staged faults can be dangerous and a special effort should be made to ensure that safe fault throwing equipment and procedures are used.

6.6.1.4.7 Fault creation

The earth fault can be created in many ways. For example, a thin copper wire with a weight may be suspended in one of the towers and released falling in a pendulum movement towards the energized conductors, thus creating an arc to earth. For some faults (specifically in indoor ambient), temporary switches could be temporarily installed.

6.6.1.5 Type of tests

6.6.1.5.1 Distant phase-to-earth fault and distant 3 phase-to-earth fault

The test assesses the sensitivity of the converters to commutation failure.

6.6.1.5.2 Close phase-to-earth fault

The test assesses the ability of controls to contain the 100 Hz or 120 Hz ripple on the d.c. voltage to an acceptable level, and sometimes to assess the ability to recover rapidly in case of automatic protective blocking during the fault.

6.6.1.5.3 Close 3 phase-to-earth fault

The test assesses the ability to re-establish the power flow rapidly.

6.6.1.5.4 AC busbar phase-to-earth fault

Purposes of the test are the following:

- a) It has the same object as for the close phase to earth fault plus.
- b) It assesses the possible consequences of fault neutral current circulation in the earthed grid.
- c) It verifies the insensitivity of the controls towards the disturbances and the proper function of the protection.

6.6.1.5.5 DC line fault

Purposes of the test are the following:

- a) The test checks the correct response of the d.c. line protection and the automatic sequence of recovery.
- b) For close faults, it checks the insulation coordination in the d.c. switchyard.
- c) For distant faults it checks whether the line protection can differentiate between line faults and station faults at the remote terminal.
- d) It checks whether there is any false operation of the d.c. protection of the sound pole.

6.6.1.6 Test acceptance criteria

Test acceptance criteria are the following:

- a) The HVDC system shall remain stable during and after the fault.
- b) There shall be no spurious operation of protection relays either in the d.c. system or in the a.c. system.
- c) Transient a.c. and d.c. voltages shall be contained within the limitation determined by the insulation coordination study.
- d) Speed of d.c. power recovery shall be within the specified time.
- e) A specified maximum number of commutation failures during a defined time period shall not be exceeded.

- f) Records should be compared with those obtained by the simulations normally achieved before the staged faults on site. Differences in response should be explained.

6.7 Loss of telecom, auxiliaries or redundant equipment

6.7.1 Loss of telecommunications between terminals

6.7.1.1 General

6.7.1.1.1 Signals type

As indicated in IEC 60919-1, different types of information may be transmitted between HVDC substations, each type requiring specific performances.

6.7.1.1.2 Signals for control

Signals for control include:

- a) power order;
- b) current order;
- c) frequency control;
- d) damping control;
- e) force retard for the remote station.

6.7.1.1.2.1 Operation orders

Operation orders include:

- a) change of control mode of operation;
- b) operation of switches;
- c) block/de-block.

6.7.1.1.2.2 Status indications

Status indications include:

- a) position of switches;
- b) number of converters in operation;
- c) measured values;
- d) alarm signals;
- e) voice communication;
- f) d.c. line fault location.

6.7.1.1.3 Consequence of a loss of telecommunications

The consequence of a loss of telecommunications is related to each of the above types of information transmitted, furthermore the most critical types of information are generally transmitted using redundant telecommunication systems and the tests should be conducted on the condition of loss of redundancy.

6.7.1.1.4 Role of telecommunications

Most HVDC systems are designed such that loss of telecommunication typically does not interrupt or significantly modify the existing level of power transmission. Telecommunications between terminals are used to improve the operating conditions, the transient performance or to provide some special control facilities such as frequency or damping control.

6.7.1.1.5 Control sequence

The loss of telecommunication should initiate a predefined control sequence that may end in freezing the power transfer to the pre-fault value.

6.7.1.1.6 Combined tests

The loss of telecommunication should be tested combined with other end-to-end tests.

6.7.1.2 Purpose of test

Purposes of the test are the following:

- a) Check that the operation of the HVDC system and its effects on the a.c. system are compliant with the specification when losing telecommunication during power transfer or during a start up sequence.
- b) To verify the message security from external influences such as noise, etc.

6.7.1.3 Test precondition

Test preconditions are the following:

- a) The proper operation of the telecommunication system should have been tested during subsystems tests at site.
- b) The function of the control loops and protection circuits should have been tested with and without telecommunication.
- c) The ability of the system to shutdown safely without telecommunication should have been tested during the basic operation tests (see 7.1).
- d) The topology of the link, the amount of power transmitted and the sequence of operation existing when the loss of telecommunication occurs shall be determined depending on the object of each individual test.
- e) During steady state operation and ramping of power/current order, the HVDC system should have transmitted power at a significant level and operated under the appropriate control mode.
- f) During start-up and shut-down sequences, the detailed test procedure should have been established depending on the specific control strategy.

6.7.1.4 Test procedure

The tests should be performed under the different modes of operation:

- a) during steady state operation, check the impact on power order/current order, transmitted power;
- b) during current or power order ramping;
- c) during start up and shut-down sequences.

The tests should be done by disconnecting all end-to-end telecommunication channels except for operator voice channels at a predetermined time. Message security should be verified by simulating external noise and/or other disturbances.

6.7.1.5 Test acceptance criteria

Test acceptance criteria are the following:

- a) The HVDC system remains stable and the effects on the a.c. systems remain within the specified limits.
- b) No unplanned operation of protective systems shall occur.

- c) Start-up and shut-down sequences shall terminate safely, with indications showing the status at which the sequence was terminated.

6.7.2 Loss of auxiliary power supplies

6.7.2.1 General

The auxiliary power supplies of an HVDC substation may be classified into three categories according to the level of reliability needed for the performance of the HVDC system:

- a) general a.c. supply with no back-up;
- b) a.c. supplies with automatic change-over to a back-up a.c. source;
- c) uninterruptible supplies including diesel back-up generators.

6.7.2.2 Purpose of test

Purposes of the test are the following:

- a) To verify that short interruptions in the auxiliary supply during change-over do not disturb the HVDC power transmission.
- b) To verify that safe and controlled shut-down of the HVDC converter station takes place in the event of a total loss of all auxiliary supplies except the uninterruptible supply.
- c) To verify that safe shut-down of the HVDC system in case of failure of the uninterruptible power supply (if any).

6.7.2.3 Test precondition

Test preconditions are the following:

- a) Proper function of change-over systems such as automatic undervoltage transfer should have been checked.
- b) Uninterruptible power supply functions, capacity and performance should have been tested.

6.7.2.4 Test procedure – Test acceptance criteria

For the a.c. supplies with automatic change-over, which are used to supply the cooling fans and pumps and other critical equipment for significant power, tests should be performed at no load and at full load. The tests should be performed separately on each type of auxiliary subsystem as follows.

- a) Loss of the entire a.c. auxiliary power

The d.c. system shall shut down safely in a coordinated sequence. If a back-up generator group is provided, it shall start up within the specified time limit and supply the appropriate load.

- b) Loss of auxiliary power with automatic change-over

A transfer to the second a.c. source shall be initiated. The time of change-over and the restart condition of induction motors shall be checked. The cooling media flow shall not be interrupted longer than specific limits of the relevant equipment.

- c) Loss of redundant supply of control and protection and communication equipment

The control and protection equipment shall continue to operate as specified.

- d) Loss of the entire supply to the control equipment

The d.c. system shall normally rely on protective functions to shut down safely.

6.7.3 Loss of redundant equipment

6.7.3.1 General

HVDC systems may contain various redundant control, protection, and measuring equipment to enhance system reliability.

6.7.3.2 Purpose of test

In case of failure, the HVDC system should take over to the sound redundant element and continue to operate as specified.

6.7.3.3 Test precondition

Function of the control and protection system with all redundant elements should be correct and have been checked.

6.7.3.4 Test procedure – Test acceptance criteria

The tests should depend greatly on the redundancy concept used for the system design. The tests should simulate the loss of redundant elements in the failure modes which are the most probable on the one hand and those which may cause the most onerous conditions for the system. The system shall respond as designed.

6.8 High power transmission tests

6.8.1 General

6.8.1.1 General

HVDC high power transmission tests verify the steady-state performance parameters of the HVDC system. Previous commissioning tests, including converter unit tests and low power transmission tests, shall have verified that the d.c. equipment functions correctly at low power.

6.8.1.2 General precondition

General preconditions are the following:

- a) Commissioning tests of all converter units should have been completed.
- b) Commissioning tests of transmission system as required for stable operation should have been completed.
- c) Environmental conditions are within the limits given in the specification.

6.8.1.3 Purpose of tests

Purposes of the tests are the following:

- a) Verify the stable operation of the HVDC system within the limits given by the specifications.
- b) Measure a.c. and d.c. harmonic levels, audible noise, corona and interference levels (if/when specified by user).
- c) Verify the overload, temperature rise and earth electrode performances are within the specified levels.

6.8.2 Steady state operation tests

6.8.2.1 General

At rated and different power level, at different specified configuration and control modes, the system parameters are measured, which provides the necessary conditions for the

measurements that verify whether the electric and audible noise are within the specific limitations.

6.8.2.2 Purpose of test

The test is to verify that the HVDC transmission can operate stably within the specific limitations at different conditions.

6.8.2.3 Test precondition

Commissioning tests of reactive power control system should have been completed. AC network conditions should be within the specified conditions.

6.8.2.4 Test procedure

Measure the parameters when the HVDC system operates in different status, including:

- a) operation at minimum and rated power and at each power level which initiates switching of a filter or reactive power component, and overload HVDC power transfer levels.
- b) various HVDC and a.c. system configurations;
- c) reduced HVDC voltage operation;
- d) normal operation with specified filter configurations;
- e) operation with filter banks or reactive power banks unavailable;
- f) steady-state range of a.c. power frequency and voltage;
- g) extremes of ambient (as far as possible);
- h) bipolar and monopolar operation with and without earth or metallic return.

6.8.2.5 Test acceptance criteria

Test acceptance criteria are the following:

- a) The operation of HVDC transmission shall be stable.
- b) The parameters of HVDC transmission shall be correct and within the specific limitations

6.8.3 Reactive power control

6.8.3.1 General

Operation of the HVDC transmission will consume reactive power and produce harmonic current and voltage. The reactive power compensation elements (a.c./d.c. filter, shunt reactor, d.c. smoothing reactor) are specifically designed to avoid that the HVDC transmission affects the connected a.c. systems. Some control functions can be checked in Subclauses 6.2.4 and 6.4.3. In other test items, some acquired data can be utilized and some functions, such as absolute minimum filter, minimum filter and automatic discharging, may also have been verified,

6.8.3.2 Purpose of test

In this subclause, with the HVDC power change, the performances and the switch curve of the reactive power compensation devices and filter equipment are measured and compared with the designed ones, which can be used to evaluate the reactive power control function and supply important references data to operation.

6.8.3.3 Test precondition

Test preconditions are the following:

- a) AC network conditions should be within specified limits.

- b) Study results should be available which estimate the levels and spectrum of harmonics from the HVDC system.
- c) AC and d.c. filter design study results should be available.
- d) Inductive coordination study results should be available.
- e) Measurements should be available which establish pre-existing background levels and spectrum of harmonic levels.
- f) Pre-commissioning test data should be available for the a.c. and d.c. filter parameters.
- g) A test instrumentation and data acquisition system should be available.
- h) Specialized harmonic measuring equipment should be available.

6.8.3.4 Test procedure

The measurements should be exercised at different specified configuration and control modes, including the following:

- a) stand-by operation;
- b) operation at minimum and rated power and at each power level which initiates switching of a filter or reactive power component, and overload HVDC power transfer levels;
- c) various HVDC and a.c. system configurations;
- d) reduced HVDC voltage operation;
- e) normal operation with specified filter configurations;
- f) operation with filter banks or reactive power banks unavailable;
- g) steady-state range of a.c. power frequency and voltage;
- h) extremes of ambient (as far as possible);
- i) bipolar and monopolar operation (with and without earth or metallic return).

6.8.3.5 Test acceptance criteria

Test acceptance criteria are the following:

- a) The performances and the switch curve of the reactive power compensation devices and filter banks shall consist of the designed ones.
- b) The performances of the HVDC transmission and the combination of the filter banks shall be within the specification.
- c) No overload shall be in the a.c. and d.c. filter banks.

6.8.4 Overload test / Temperature rise measurements

6.8.4.1 General

HVDC systems may be designed and allowed to operate in an overload condition where the HVDC power transfer level is greater than the rated value. Overload operation may result in reduced performance of the HVDC system for the following reasons:

- a) equipment life expectancy reduced due to increased thermal stresses;
- b) reduced reliability due to use of redundant equipment during overload operation;
- c) limited operating range due to ambient temperature;
- d) restricted performance range for such critical operating parameters as reactive power compensation and harmonic filter performance;
- e) control and instrumentation limits.

Operating conditions and design requirements of the a.c. and d.c. systems should be able to support the overload operation without component damage. Major equipment which can be directly affected by overload operation includes the thyristor valves, valve cooling system,

converter transformers, harmonic filters, smoothing reactor, current and voltage transformers, bushings, bus work, and transmission lines.

All components in an HVDC system are designed for a certain permissible operating temperature. They are either cooled naturally or require forced cooling. Special cooling systems are required for the main components such as valves, transformers and smoothing reactors. For availability reasons, most of the cooling systems have redundancy. The loading tests should include a complete performance test of the cooling systems. Overload capabilities depend on the loading capability of the main components and the ambient temperature.

The heat run test, also known as the loading test, verifies that the HVDC transmission operates in stable manner for a specified period at the rated or overload power level. If any loss tests additional to those performed in the factory have been specified, they may be performed during the loading tests.

6.8.4.2 Purpose of test

Purposes of the test are the following:

- a) To verify the HVDC systems overload performance capability.
- b) To confirm the temperature rise of the individual equipment within acceptance limits.
- c) To verify the proper function of all cooling systems with respect to cooling controls and redundancy requirements.
- d) To verify the loading capability within specified temperatures of all major HVDC system components and the total system under rated load conditions and, as far as possible, at overload conditions.

6.8.4.3 Test precondition

Test preconditions are the following:

- a) Factory heat-run test results of major equipment should be available.
- b) AC networks and HVDC transmission systems should have been prepared for overload tests.
- c) Temperature monitoring equipment should have been put in place.
- d) Ambient conditions should be compatible with requirements.
- e) The relevant part of the HVDC system should be ready for operation.
- f) The a.c. systems should be available for power transfer at levels as required for the loading test.
- g) The ambient temperatures should ideally be close to the maximum design temperature.
- h) For test maximum overload conditions ambient temperatures should be as low as possible.

6.8.4.4 Test procedure

The HVDC system should be operated at rated load prior to commencement of the overload tests for a period of time necessary to achieve thermal equilibrium of major electrical components such as converter transformers, d.c. smoothing reactors, thyristor valves, a.c. and d.c. harmonic filters, and valve cooling system.

After the temperature of the major equipment has thermally stabilized at full load (typically 12 h to 18 hours), the HVDC system can be operated under the overload condition which is compatible with the existing ambient conditions and the temperature rise of major electrical components recorded. In addition, the performance of the valve cooling system should be monitored and temperature monitoring devices should be employed to check the busbar, connection points, terminations, neutral connections, and switch contacts.

The HVDC system should operate in a mode of operation allowing the HVDC components to reach their maximum operating temperature. In most cases this will be achieved at the maximum current level, at maximum ambient temperature and with the cooling system redundancy not in use.

In some applications, the HVDC components will have their maximum loading and operating temperature at a different mode of operation than the maximum current level (e.g. with firing angles close to 90° electrical).

The loading test should be performed with ample duration to ensure that all components have reached a steady state operating temperature. If maximum ambient temperature is not available, the tests shall be performed at the existing ambient temperature and the anticipated component temperatures at maximum ambient temperature shall be calculated from design load curves.

The temperatures are monitored by means of temperature indicators or by infrared scanning. Ambient temperature, room temperatures and cooling circuit temperature will be recorded. All equipment should also be monitored by visual inspection.

For overload conditions the cooling systems may be operated with all available redundancy. Ambient conditions may support the cooling capacity.

After the loading tests are finished, gas in oil analysis should be performed for the major oil filled components.

6.8.4.5 Test acceptance criteria

The maximum operating temperatures and temperature rise of the equipment shall be within specified limits. The maximum operating temperature of equipment being tested should be corrected to maximum ambient temperature to compensate for lower ambient temperatures during test.

- a) Neither under normal operating conditions nor under overload conditions, shall the design temperature rise of any HVDC component be exceeded.
- b) No hotspots shall occur in the busbar and the connectors.
- c) The cooling control shall control the cooling systems to dissipate all heat losses up to specified ambient conditions.
- d) The power capability shall be in accordance with the specified loading curve.
- e) Proper function of the various cooling control circuits and the redundancy requirements shall be verified.

6.9 Acceptance tests

6.9.1 General

HVDC system performance and interference tests verify the performance parameters of the HVDC system and that electrical and audible noise interference caused by the HVDC system are within specified limits. All parties that may be affected by operation of the HVDC system should be coordinated with in advance. The parties which may be affected can include the local communities nearby converter stations and d.c. transmission lines, telephone utilities, railroad companies, pipeline companies, etc.

6.9.2 Harmonic performance and filter components rating

6.9.2.1 General

The power conversion process in HVDC systems results in the generation of harmonic currents and voltages which can affect the interconnected a.c. systems, d.c. network, and third party

electrical systems. Factors considered in the design and harmonic studies of HVDC systems to minimize the level of harmonics propagated from the HVDC system into the a.c. and d.c. network include the following:

- a) a.c. system network impedance;
- b) harmonic frequencies of concern (characteristic and uncharacteristic);
- c) harmonic magnification (resonance) on the a.c. network;
- d) valve firing angle;
- e) converter transformer reactance and firing angle unbalance;
- f) unbalanced impedances of a.c. system and harmonic filters;
- g) transformer saturation effects and stray capacitance;
- h) a.c. system distortion and interference limits;
- i) sensitivity of adjacent open-wire systems;
- j) HVDC control system instabilities and interactions with other active devices;
- k) pre-existing harmonics on the a.c. network;
- l) HVDC configuration and earth resistivity;
- m) ambient temperature range;
- n) phase angle relationship between a.c. systems;
- o) a.c. and d.c. filter design.

AC harmonic filters connected to the a.c. bus reduce the harmonic voltages appearing on the interconnected a.c. network and the harmonic currents injected into the a.c. network to specified levels.

For HVDC systems with overhead transmission lines, smoothing reactors together with d.c. filtering circuits are typically installed in the d.c. circuit to reduce the harmonic currents to levels which will prevent interference with third party telephone or electrical systems.

The loading of the a.c. and d.c. harmonic filters should be checked and the filter components ratings verified.

6.9.2.2 Purpose of test

Purposes of the test are the following:

- a) To confirm that the harmonic voltages and currents produced by the HVDC system are reduced by the a.c. and d.c. filters to conform to specified limits.
- b) To verify that the harmonics do not cause unacceptable interference with third party telephone or electrical systems.
- c) To demonstrate that harmonic performance is acceptable when operated in various configurations and under required contingency modes.
- d) To verify that the loading of the filter components is within the individual component ratings.

6.9.2.3 Test precondition

Test preconditions are the following:

- a) AC network conditions should be within specified limits.
- b) Study results should be available which estimate the levels and spectrum of harmonics from the HVDC system.
- c) AC and d.c. filter design study results should be available.
- d) Inductive coordination study results should be available.

- e) Measurements should be available which establish pre-existing background levels and spectrum of harmonic levels.
- f) Pre-commissioning test data should be available for the a.c. and d.c. filter parameters.
- g) A test instrumentation and data acquisition system should be available.
- h) Specialized harmonic measuring equipment should be available.

6.9.2.4 Test procedure

The harmonic measurements should be performed in those specified HVDC system configurations and operation modes. A test plan which identifies these configurations and operation modes along with the physical locations for the harmonic measurements should be established, considering the following HVDC system operating conditions:

- a) stand-by operation;
- b) operation at minimum and rated power and at each power level which initiates switching of a filter or reactive power component, and overload HVDC power transfer levels;
- c) various HVDC and a.c. system configurations;
- d) any special condition generating maximum harmonics;
- e) reduced HVDC voltage operation;
- f) normal operation with specified filter configurations;
- g) operation at larger-than-normal firing angles;
- h) operation with filter banks or reactive power banks unavailable;
- i) steady-state range of a.c. power frequency and voltage;
- j) extremes of ambient (as far as possible);
- k) automatic filter tuning;
- l) d.c. harmonics test should consider the following additional items:
 - 1) equipment safety from induced voltage;
 - 2) sata transmission and railway signal circuit effects;
 - 3) voice communication circuit effects;
 - 4) excitation of resonance conditions between the HVDC line and earth electrode line;
 - 5) converter transformer d.c. currents in the neutral;
 - 6) harmonic impact on minimum current operation;
 - 7) bipolar and monopolar operation with and without earth or metallic return.

During the harmonic measurement tests, the environmental conditions should be noted and recorded due to the sensitivity of the harmonic filters to ambient temperature conditions or weather.

6.9.2.5 Test acceptance criteria

Test acceptance criteria are the following:

- a) The results of the performance measurements shall verify that the a.c. and d.c. harmonic voltages and currents are within the specified limits and interference to third party electrical systems is within acceptable limits.
- b) The tests shall confirm that operating restrictions of the HVDC system and a.c. and d.c. filter configurations are within specified limits.
- c) The a.c. and d.c. filter components shall not be overloaded.

6.9.3 Audible noise

6.9.3.1 General

HVDC systems emit noise in the audible-frequency spectrum. The source of the audible noise (AN) in HVDC systems is from terminal equipment and HVDC transmission lines and can be categorized as follows.

a) Component generated audible noise

Related devices include converter transformers, d.c. smoothing reactors, shunt reactors, a.c. and d.c. harmonic filter reactors and capacitors, thyristor valves, cooling system, and auxiliary equipment. AN will vary with loading conditions and firing angle changes.

b) Conductor generated audible noise

Related devices include corona phenomena on HVDC transmission lines, substation busbar, and outdoor equipment. The AN source is associated with ionization phenomena near conductive surfaces when the electric field strength is high enough to cause a breakdown of the surrounding air. As such, AN generated by corona can vary with environmental and ambient conditions due to conductive surface irregularities and contamination. AN from d.c. generated corona is usually higher under dry ambient conditions.

c) Impact generated audible noise

Related devices include operation of equipment such as power circuit breakers, disconnect switches, etc.

AN limits within the converter station facility, including building interiors, and along the perimeter of the HVDC system are specified to ensure that applicable regulations and codes of practice are met. In some cases, special noise abatement measures may be required to reduce the levels and spectrum of AN from the HVDC system.

6.9.3.2 Purpose of test

The AN tests are to measure and verify that the AN caused by the HVDC system is within specified limits.

6.9.3.3 Test precondition

Test preconditions are the following:

- a) The locations for pre- and post-construction measurements should have been defined.
- b) Measurements should have been available which establish preconstruction background levels and spectrum of AN levels.
- c) Study results should have been available which estimate the levels and spectrum of AN from the HVDC system.
- d) Factory AN test results should have been available for applicable equipment.
- e) Test instrumentation and data acquisition system should have been available.

6.9.3.4 Test procedure

AN tests should be performed at predetermined locations in those HVDC system configurations and modes of operation specified. A test plan which identifies these configurations and physical locations for the AN measurements should be established, considering the following HVDC system operating conditions as applicable:

- a) stand-by operation;
- b) minimum, intermediate, rated, and applicable overload HVDC power transfer levels;
- c) any special condition generating maximum AN;

d) long term measurement considerations (when required).

The presence of corona can create AN. Corona can be observed by visual inspection with the use of binoculars or located with the use of ultra sonic corona detection devices.

During the AN tests, the environmental conditions should be noted and recorded due to the sensitivity of AN measurements to ambient conditions, such as air temperature, barometric pressure, relative humidity, wind speed and direction, and background acoustic noise.

Instrumentation and AN measurement procedures should follow the specified requirements or applicable standards.

6.9.3.5 Test acceptance criteria

Test criteria for AN levels resulting from HVDC systems are project specific and depend to some degree on surrounding environments. The AN levels measured with the HVDC system in operation should be within the design limits specified.

6.9.4 Electromagnetic interference tests

6.9.4.1 General

HVDC systems produce voltages and currents in conductors which may cause interference from both the conducted energy and radiated energy. Conductor corona pulses and partial discharges on insulators are also potential sources of electrical interference from HVDC systems.

Filtering devices, shielding, and noise suppression techniques are implemented to minimize interference. Since electrical interference has the potential of affecting third party electrical systems, the commissioning test program should include coordinated tests with operators of interference-sensitive equipment. Design criteria for interference levels resulting from HVDC systems are project specific and depend on the surrounding environments and regulations. Interference limits imposed typically consider the following:

- a) radio interference (RI);
- b) television interference (TVI);
- c) telephone carrier interference (TCI);
- d) microwave communication system interference (MCSI);
- e) railroad signal interference (RSI);
- f) power line carrier interference (PLCI).

6.9.4.2 Purpose of test

The interference tests are to measure and verify that the interference levels caused by the HVDC system are within required limits and that there is no degradation of low-level electric circuits (e.g. telephone networks, computers, radio and television systems, railroad signal equipment, and other electronic apparatus).

6.9.4.3 Test precondition

Test preconditions are the following:

- a) Study results should be available which estimate the levels of interference expected as a result of HVDC system operations.
- b) Coordination should have been established with operators of interference-sensitive equipment.
- c) All interference mitigating equipment should be in service together with HVDC system operation.

- d) HVDC station controls and protection should have been verified to be immune from interference.
- e) Test instrumentation and data acquisition system should be available.

6.9.4.4 Test procedure

Interference tests for the HVDC system can be broadly classified into the following separate groups.

a) HVDC converter station tests

Measurements should be taken within and adjacent to the fenced boundary of the facilities.

b) Transmission line tests

Measurements should be taken along a perimeter contour of the a.c. and HVDC transmission lines servicing the HVDC system.

The interference tests should be performed at predetermined locations and in those HVDC system configurations and modes of operation specified. A test plan which identifies these configurations and levels along with the physical locations for the interference measurements should be established, considering the following HVDC system operating conditions:

- a) stand-by operation;
- b) minimum, intermediate, rated and applicable overload HVDC power transfer levels;
- c) any special condition generating maximum interference;
- d) number of points and number of measurements;
- e) test plan which identifies the bandwidths and measuring techniques, correction factors, accuracy, antenna types, standards (where applicable), frequency scans and spectrums, operating configurations and modes of the HVDC system, ambient weather conditions, voltages, conductor configuration, structure type and material), and elevation.

6.9.4.5 Test acceptance criteria

The interference levels measured with the HVDC system in operation should be within the specified design limits and cause no degradation of low-level electric circuits.

6.9.5 Earth electrode test

6.9.5.1 General

The earth electrodes for a bipolar configured HVDC transmission system provide an earth reference for the neutral bus at each converter station. The earth electrodes are generally designed to permit the HVDC system to operate for a pre-defined time period in the monopolar earth return mode when one pole of the bipole is out of service. The earth electrodes for monopolar systems are designed to permit continuous operation. Since earth return operation may interfere with third party communication circuits and may cause corrosion of underground structures, the commissioning test program should include coordination with third parties.

6.9.5.2 Purpose of test

The objects of the earth electrode test are to verify the design of the earth electrodes and establish the maximum measured interference levels in various operating modes. Design criteria for HVDC earth electrodes are project specific and depend on the local soil conditions, anticipated operating modes, and duration of earth return operation in the worst case. Design criteria typically considered include the following:

- a) current rating;
- b) temperature rise;

- c) thermal time constant;
- d) current distribution between sub-electrodes;
- e) current density at the earth electrode surface;
- f) earth resistivity design value;
- g) resistance of earth electrode to remote earth;
- h) earth electrode resistance;
- i) overload current capability;
- j) step and touch potential.

6.9.5.3 Test precondition

Test preconditions are the following:

- a) Earth electrode pre-commissioning tests should have been completed including measurement of structure-to-soil, potential, current-in-structure, soil potential, soil resistivity, structure-to-remote electrode-potential, and background interference level.
- b) Test stations for cathodic protection and stray current measurements should have been established.
- c) Coordination should have been established with all participants, e.g., railroad operators, telephone companies, municipalities, underground utility operators, earth electrode supplier, and HVDC supplier.
- d) Test coordination centre and communication method should have been established.
- e) Test instrumentation and data acquisition system should be available.

6.9.5.4 Test procedure

6.9.5.4.1 Testing

System tests for commissioning of the earth electrode can be broadly classified into the following separate groups.

a) Low current tests

10 % to 20 % rated direct current is utilized to determine the basic earth electrode characteristics and identify the areas of potential interference.

b) Full rated tests

The direct current is increased above the low current test level in incremental steps up to the full current rating. Periodic cycling and the magnitude of the direct current incremental steps should be based upon a test schedule/plan.

6.9.5.4.2 Instruments

Recording instruments should be installed at all test points and areas of special concern that are identified during the low current tests. The duration of the tests at each direct current level should be appropriate for the thermal time constants of concern and allow for the following test measurements to be taken:

- a) stray current magnitude caused by test current in affected structures;
- b) change in stray current flow caused by test current in affected structure;
- c) change in potential caused by test current of structure-to soil;
- d) current distribution in each earth electrode well or earth electrode section;
- e) temperature rise versus test time to establish limits of full current test;
- f) induced voltage on communication circuits;

- g) stray currents in a.c. system transformer neutrals.

Structure-to-soil potential should be measured with the reference electrode directly above buried structures or within one foot of above ground structures such as railroads, and towers.

6.9.5.5 Test acceptance criteria

Test acceptance criteria are the following:

- a) The characteristics of the earth electrodes shall be within the specified design limits including temperature rise, voltage distribution, resistance, and uniform current distribution among different earth electrode wells or earth electrode sections.
- b) The results of the coordinated tests should be analysed and any unusual results should be investigated and resolved between the affected parties. Issues from “electrode station design” and “site location of electrode station” should be separately analysed.

7 Trial operation

7.1 General

Trial operation provides the opportunity to operate the HVDC system together with the connected a.c. systems for an extended period of time. Operation shall be as close as possible to real operating conditions.

The time period is a particular time of accurate observation of the complete HVDC system and all its components.

The HVDC system should be operated by the user's personnel, thus additional training of manpower particularly in fault analysis and system performance can take place.

7.2 Purpose of test

The trial operation verifies the performance and the availability of the HVDC system during a specified period of operation under real but specified conditions.

7.3 Test precondition

Test preconditions are the following:

- a) All equipment should be available.
- b) All power transmission tests should have been completed.
- c) Operators should have been sufficiently trained to conduct system operation.
- d) Power transfer schedules between the a.c. systems should have been coordinated.
- e) The a.c. system configurations should be within specified limits.
- f) AC system configuration data should be available.
- g) The station recorders are sufficient for monitoring and recording purposes. Some additional recording equipment can be complemented for the purpose of collecting data and design study verification.

7.4 Test procedure

During trial operation, the HVDC system shall be utilized in such a manner as required by the original design and the user's intended use.

Typically trial operation should be performed for a period of 1 to 4 weeks. During this period, operation shall be conducted by the user's personnel, and the manufacturer's assistance shall be limited.

During trial operation accurate observation of the complete HVDC system and all its components should be carried out.

Any abnormal or unexpected responses or incidents which affect the availability of the system should be carefully analysed to determine the cause.

If an HVDC system is built in stages, trial operation could be allocated to the individual stages.

The tests having no influence on the behaviour and safety of the HVDC system (e.g. radio interference test etc.) can, if mutually agreed, be performed during or after trial operation.

7.5 Test acceptance criteria

Test acceptance criteria are the following:

- a) During trial operation no forced outages or disturbances due to malfunction of any HVDC equipment shall occur.
- b) If modifications or adjustments arise during trial operation, action shall be taken. Depending on the modifications or adjustments a portion of or the complete trial operation may be repeated/extended.
- c) The criteria for repetition of part or the entire test shall be agreed prior to the start of trial operation.

8 System test plan and documentation

8.1 General

The documentation including the system test plan required to perform the system tests, consist of:

- a) plant documentation and operating manuals;
- b) system study reports and technical specifications;
- c) inspection and test plan;
- d) system test program;
- e) test procedures for each test;
- f) documentation of system test results;
- g) deviation reports.

8.2 Plant documentation and operating manual

The following documents and operating manuals should be provided:

- a) Plant documentation provides sufficient up to date information on all equipment installed and its function, location and interconnections.
- b) Up to date settings of the control and protection equipment shall be provided, including the data acquisition system.
- c) The operating manuals provide sufficient training guidance for operators to execute all switching and control operations under all operating conditions.

8.3 System study reports and technical specification

System study reports shall provide the information needed to operate the HVDC system together with the connected a.c. systems within the specified limits. The examples of particular system study reports required for this purpose are:

- a) a.c./d.c. system interactions;

- b) reactive power control;
- c) protection coordination;
- d) control coordination, changing of system configuration and switching.

8.4 Inspection and test plan

Inspection and test plan together with the system test program form the system test plan.

This standard is structured in a logical sequence and can thus provide background information for any specific project application.

Each inspection and test plan should comprise the following as appropriate and similar to this standard:

- a) specific object per test;
- b) test procedure (reference to standard procedures);
- c) test acceptance criteria;
- d) test precondition;
- e) references to system studies on specifications;
- f) references to off-site tests;
- g) special conditions.

All inspections and tests to be performed shall be identified with a unique number. This number should also be used as a cross reference on all standard test procedures and for the documentation of the inspection and system test results.

The inspection and test plan shall also contain all required load levels and load changes as well as the expected effective short circuit level (ESCR).

Procedures for each test should be thoroughly discussed with all parties involved before finalizing the test schedule.

All inspections and systems tests shall be mutually agreed among all parties concerned in advance to allow sufficient time for scheduling. Contingency measures in case of any failure shall also be discussed.

8.5 System test program

The system test program schedules the system tests. It coordinates the requirements with dispatch authorities and specifies:

- a) preconditions including environmental and a.c. systems configuration and generation schedules;
- b) preconditions to be selected (control locations, control mode, control level energy transfer mode);
- c) initial and final HVDC system configuration;
- d) energy direction;
- e) power levels, duration and ramp rates.

The system test program shall identify the test team and the test leader for each individual test, for each converter terminal, the load dispatch centre, affected substations or power stations, and test locations where faults or short circuits are created.

The test schedule should have suitable hold points to check the status of protection, auxiliaries and fire protection.

Final permission from the operating authorities shall be requested immediately before test execution.

Test duration should be planned with an adequate time margin to allow for contingencies. As system tests have a high potential of causing major disturbance on the HVDC and the connected a.c. systems, consideration shall be given to execution during off peak hours.

It is also preferable that the a.c. systems be configured to have sufficient loading margin to sustain total HVDC load rejection.

In case of planning staged fault tests, ample precaution and support by specialist staff should be provided including studies showing the effect of faults on the a.c. system.

8.6 Test procedure for each test

The test procedures describe for each individual test the instructions to be followed by the test team.

The preconditions to be fulfilled and the references to system studies and specifications or off-site tests are defined.

Test objects, procedure and acceptance criteria specify the actual performance of each specific test.

The test procedure also lists the test equipment to be used and the measurements to be taken, and the exact measurement points. Cross reference to the documentation of system test results shall be identified by using a numbering system. The same numbering system shall also refer to the application of the test procedure and the inspection and test plan.

The test procedures may be one report, specifically written for the project, or an assortment of generic test descriptions compiled for the project. In case generic test descriptions are used, these should be packaged complete with an index.

8.7 Documentation of system test results

The documentation of system test results shall be formed from a commissioning report describing the results of each test series, together with the test results, data acquisition traces and data captured by station recorders, sequence of event recorders printout, alarm printout and other special results.

A failed test should be recorded in a failure report which shall have the test number description and the reason for failure noted. Upon correction of the problem the manufacturer should briefly describe the modification on the same failure report and indicate that the system is ready for a retest of the failed test. All modifications shall be formally tracked according to the applicable quality assurance procedures in all applicable parts of the documentation.

A detailed description of the modification should be provided in the deviation report. For tracking the status of failed tests a database shall be kept, indicating the status (new, modification implemented, retested, passed, failed again) of each test.

A record of equipment outages, malfunctions and diagnostic test results related to the commissioning shall be kept.

Any special occurrence on the results of any test shall be highlighted by the test team prior to submitting the commissioning report.

All system test results should be well indexed and referenced to the individual tests.

8.8 Deviation report

The deviation report shall form part of the commissioning report with a detailed description of modifications and reference to the specific tests and test results.

A discussion of the modifications carried out should be included for further reference.

Bibliography

IEC 60700-1:2008, *Thyristor valves for high-voltage direct current (HVDC) power transmission – Part 1: Electrical testing*¹

IEC/TR 60919-1, *Performance of high-voltage direct current (HVDC) systems with line commutated converters – Part 1: Steady-state conditions*

IEC 60919-3, *Performance of high-voltage direct current (HVDC) systems with line-commutated converters – Part 3: Dynamic conditions*

IEC 61000-4-3, *Electromagnetic compatibility (EMC) – Part 4-3: Testing and measurement techniques – Radiated, radio-frequency, electromagnetic field immunity test*

IEC 61803, *Determination of power losses in high-voltage direct current (HVDC) converter stations*

¹ There exists a consolidated edition 1.2 (2008) consisting of edition 1 and its Amendments 1 (2003) and 2 (2008).

British Standards Institution (BSI)

BSI is the national body responsible for preparing British Standards and other standards-related publications, information and services.

BSI is incorporated by Royal Charter. British Standards and other standardization products are published by BSI Standards Limited.

About us

We bring together business, industry, government, consumers, innovators and others to shape their combined experience and expertise into standards-based solutions.

The knowledge embodied in our standards has been carefully assembled in a dependable format and refined through our open consultation process. Organizations of all sizes and across all sectors choose standards to help them achieve their goals.

Information on standards

We can provide you with the knowledge that your organization needs to succeed. Find out more about British Standards by visiting our website at bsigroup.com/standards or contacting our Customer Services team or Knowledge Centre.

Buying standards

You can buy and download PDF versions of BSI publications, including British and adopted European and international standards, through our website at bsigroup.com/shop, where hard copies can also be purchased.

If you need international and foreign standards from other Standards Development Organizations, hard copies can be ordered from our Customer Services team.

Subscriptions

Our range of subscription services are designed to make using standards easier for you. For further information on our subscription products go to bsigroup.com/subscriptions.

With **British Standards Online (BSOL)** you'll have instant access to over 55,000 British and adopted European and international standards from your desktop. It's available 24/7 and is refreshed daily so you'll always be up to date.

You can keep in touch with standards developments and receive substantial discounts on the purchase price of standards, both in single copy and subscription format, by becoming a **BSI Subscribing Member**.

PLUS is an updating service exclusive to BSI Subscribing Members. You will automatically receive the latest hard copy of your standards when they're revised or replaced.

To find out more about becoming a BSI Subscribing Member and the benefits of membership, please visit bsigroup.com/shop.

With a **Multi-User Network Licence (MUNL)** you are able to host standards publications on your intranet. Licences can cover as few or as many users as you wish. With updates supplied as soon as they're available, you can be sure your documentation is current. For further information, email bsmusales@bsigroup.com.

BSI Group Headquarters

389 Chiswick High Road London W4 4AL UK



Revisions

Our British Standards and other publications are updated by amendment or revision.

We continually improve the quality of our products and services to benefit your business. If you find an inaccuracy or ambiguity within a British Standard or other BSI publication please inform the Knowledge Centre.

Copyright

All the data, software and documentation set out in all British Standards and other BSI publications are the property of and copyrighted by BSI, or some person or entity that owns copyright in the information used (such as the international standardization bodies) and has formally licensed such information to BSI for commercial publication and use. Except as permitted under the Copyright, Designs and Patents Act 1988 no extract may be reproduced, stored in a retrieval system or transmitted in any form or by any means – electronic, photocopying, recording or otherwise – without prior written permission from BSI. Details and advice can be obtained from the Copyright & Licensing Department.

Useful Contacts:

Customer Services

Tel: +44 845 086 9001

Email (orders): orders@bsigroup.com

Email (enquiries): cservices@bsigroup.com

Subscriptions

Tel: +44 845 086 9001

Email: subscriptions@bsigroup.com

Knowledge Centre

Tel: +44 20 8996 7004

Email: knowledgecentre@bsigroup.com

Copyright & Licensing

Tel: +44 20 8996 7070

Email: copyright@bsigroup.com

...making excellence a habit.™