

BS EN 61968-8:2016



BSI Standards Publication

# Application integration at electric utilities — System interfaces for distribution management

Part 8: Interfaces for customer operations

### **National foreword**

This British Standard is the UK implementation of EN 61968-8:2016. It is identical to IEC 61968-8:2015.

The UK participation in its preparation was entrusted to Technical Committee PEL/57, Power systems management and associated information exchange.

A list of organizations represented on this committee can be obtained on request to its secretary.

This publication does not purport to include all the necessary provisions of a contract. Users are responsible for its correct application.

© The British Standards Institution 2016.

Published by BSI Standards Limited 2016

ISBN 978 0 580 64105 3

ICS 33.200

**Compliance with a British Standard cannot confer immunity from legal obligations.**

This British Standard was published under the authority of the Standards Policy and Strategy Committee on 31 May 2016.

### **Amendments/corrigenda issued since publication**

<b>Date</b>	<b>Text affected</b>
-------------	----------------------

---

EUROPEAN STANDARD

**EN 61968-8**

NORME EUROPÉENNE

EUROPÄISCHE NORM

May 2016

ICS 33.200

English Version

Application integration at electric utilities - System interfaces for  
distribution management - Part 8: Interfaces for customer  
operations  
(IEC 61968-8:2015)

Application integration at electric utilities - System interfaces  
for distribution management - Part 8 : interface standard for  
customer support  
(IEC 61968-8:2015)

Integration von Anwendungen in Anlagen der  
Elektrizitätsversorgung - Systemschnittstellen für  
Netzführung - Teil 8: Schnittstellen Normen für den  
Kundendienst  
(IEC 61968-8:2015)

This European Standard was approved by CENELEC on 2015-07-01. CENELEC members are bound to comply with the CEN/CENELEC Internal Regulations which stipulate the conditions for giving this European Standard the status of a national standard without any alteration.

Up-to-date lists and bibliographical references concerning such national standards may be obtained on application to the CEN-CENELEC Management Centre or to any CENELEC member.

This European Standard exists in three official versions (English, French, German). A version in any other language made by translation under the responsibility of a CENELEC member into its own language and notified to the CEN-CENELEC Management Centre has the same status as the official versions.

CENELEC members are the national electrotechnical committees of Austria, Belgium, Bulgaria, Croatia, Cyprus, the Czech Republic, Denmark, Estonia, Finland, Former Yugoslav Republic of Macedonia, France, Germany, Greece, Hungary, Iceland, Ireland, Italy, Latvia, Lithuania, Luxembourg, Malta, the Netherlands, Norway, Poland, Portugal, Romania, Slovakia, Slovenia, Spain, Sweden, Switzerland, Turkey and the United Kingdom.



European Committee for Electrotechnical Standardization  
Comité Européen de Normalisation Electrotechnique  
Europäisches Komitee für Elektrotechnische Normung

**CEN-CENELEC Management Centre: Avenue Marnix 17, B-1000 Brussels**

## **European foreword**

The text of document 57/1548/FDIS, future edition 1 of IEC 61968-8, prepared by IEC/TC 57, "Power systems management and associated information exchange" was submitted to the IEC-CENELEC parallel vote and approved by CENELEC as EN 61968-8:2016.

The following dates are fixed:

- latest date by which the document has to be implemented at national level by publication of an identical national standard or by endorsement (dop) 2016-11-13
- latest date by which the national standards conflicting with the document have to be withdrawn (dow) 2019-05-13

Attention is drawn to the possibility that some of the elements of this document may be the subject of patent rights. CENELEC [and/or CEN] shall not be held responsible for identifying any or all such patent rights.

## **Endorsement notice**

The text of the International Standard IEC 61968-8:2015 was approved by CENELEC as a European Standard without any modification.

## Annex ZA (normative)

### Normative references to international publications with their corresponding European publications

The following documents, in whole or in part, are normatively referenced in this document and are indispensable for its application. For dated references, only the edition cited applies. For undated references, the latest edition of the referenced document (including any amendments) applies.

NOTE 1 When an International Publication has been modified by common modifications, indicated by (mod), the relevant EN/HD applies.

NOTE 2 Up-to-date information on the latest versions of the European Standards listed in this annex is available here: [www.cenelec.eu](http://www.cenelec.eu).

<u>Publication</u>	<u>Year</u>	<u>Title</u>	<u>EN/HD</u>	<u>Year</u>
IEC 60050	-	International Electrotechnical Vocabulary (IEV)	-	-
IEC 61968-1	-	Application integration at electric utilities - System interfaces for distribution management -- Part 1: Interface architecture and general requirements	EN 61968-1	-
IEC 61968-6	-	Application integration at electric utilities - System interfaces for distribution management - Part 6: Interfaces for maintenance and construction	-	-
IEC 61968-11	-	Application integration at electric utilities - System interfaces for distribution management -- Part 11: Common information model (CIM) extensions for distribution	EN 61968-11	-
IEC 61968-100	-	Application integration at electric utilities - System interfaces for distribution management -- Part 100: Implementation profiles	EN 61968-100	-
IEC 61970-301	-		EN 61970-301	-
IEC/TS 61968-2	-	Application integration at electric utilities - System interfaces for distribution management -- Part 2: Glossary	-	-

## CONTENTS

FOREWORD .....	4
1 Scope .....	7
2 Normative references .....	7
3 Terms, definitions and abbreviations .....	7
3.1 Terms and definitions.....	7
3.2 Abbreviations.....	8
4 Reference and information models .....	8
4.1 Reference model.....	8
4.1.1 General .....	8
4.1.2 Customer support (CS).....	9
4.2 Customer support functions and components .....	9
4.3 Static information model .....	9
4.3.1 General .....	9
4.3.2 Classes for customer support .....	9
5 Customer support message types.....	10
5.1 General.....	10
5.2 Trouble ticket.....	11
5.2.1 General .....	11
5.2.2 Message format.....	12
5.3 Incident information .....	12
5.3.1 General .....	12
5.3.2 Message format.....	14
5.4 Service request.....	15
5.4.1 General .....	15
5.4.2 Message format.....	16
5.5 Service order .....	17
5.5.1 General .....	17
5.6 Work request .....	17
5.6.1 General .....	17
5.7 Customer agreement .....	18
5.7.1 General .....	18
5.7.2 Message format.....	20
Annex A (normative) XML schemas for message payloads .....	21
Bibliography.....	58
Figure 1 – IEC 61968-8 context model .....	8
Figure 2 – Example of trouble ticket exchange between CIS and OMS.....	11
Figure 3 – Trouble ticket message .....	12
Figure 4 – Example of incident information exchange between OMS and CIS .....	13
Figure 5 – Incident information message.....	14
Figure 6 – Example of a service request exchange between CIS and WMS .....	15
Figure 7 – Service request message .....	16
Figure 8 – Example of a service order exchange between CIS and WMS.....	17
Figure 9 – Example of a work request exchange between CIS and WMS .....	18

Figure 10 – Example of a customer exchange between CIS and external or third party systems ..... 19

Figure 11 – Customer agreement message ..... 20

Figure A.1 – Trouble ticket XSD ..... 24

Figure A.2 – Incident information XSD ..... 28

Figure A.3 – Customer agreement XSD ..... 35

Figure A.4 – Service request XSD ..... 57

Table 1 – Document overview for IEC 61968-8 ..... 6

Table 2 – Business functions and abstract components ..... 9

Table 3 – Customer support classes ..... 10

## INTERNATIONAL ELECTROTECHNICAL COMMISSION

**APPLICATION INTEGRATION AT ELECTRIC UTILITIES –  
SYSTEM INTERFACES FOR DISTRIBUTION MANAGEMENT –****Part 8: Interfaces for customer operations**

## FOREWORD

- 1) The International Electrotechnical Commission (IEC) is a worldwide organization for standardization comprising all national electrotechnical committees (IEC National Committees). The object of IEC is to promote international co-operation on all questions concerning standardization in the electrical and electronic fields. To this end and in addition to other activities, IEC publishes International Standards, Technical Specifications, Technical Reports, Publicly Available Specifications (PAS) and Guides (hereafter referred to as "IEC Publication(s)"). Their preparation is entrusted to technical committees; any IEC National Committee interested in the subject dealt with may participate in this preparatory work. International, governmental and non-governmental organizations liaising with the IEC also participate in this preparation. IEC collaborates closely with the International Organization for Standardization (ISO) in accordance with conditions determined by agreement between the two organizations.
- 2) The formal decisions or agreements of IEC on technical matters express, as nearly as possible, an international consensus of opinion on the relevant subjects since each technical committee has representation from all interested IEC National Committees.
- 3) IEC Publications have the form of recommendations for international use and are accepted by IEC National Committees in that sense. While all reasonable efforts are made to ensure that the technical content of IEC Publications is accurate, IEC cannot be held responsible for the way in which they are used or for any misinterpretation by any end user.
- 4) In order to promote international uniformity, IEC National Committees undertake to apply IEC Publications transparently to the maximum extent possible in their national and regional publications. Any divergence between any IEC Publication and the corresponding national or regional publication shall be clearly indicated in the latter.
- 5) IEC itself does not provide any attestation of conformity. Independent certification bodies provide conformity assessment services and, in some areas, access to IEC marks of conformity. IEC is not responsible for any services carried out by independent certification bodies.
- 6) All users should ensure that they have the latest edition of this publication.
- 7) No liability shall attach to IEC or its directors, employees, servants or agents including individual experts and members of its technical committees and IEC National Committees for any personal injury, property damage or other damage of any nature whatsoever, whether direct or indirect, or for costs (including legal fees) and expenses arising out of the publication, use of, or reliance upon, this IEC Publication or any other IEC Publications.
- 8) Attention is drawn to the Normative references cited in this publication. Use of the referenced publications is indispensable for the correct application of this publication.
- 9) Attention is drawn to the possibility that some of the elements of this IEC Publication may be the subject of patent rights. IEC shall not be held responsible for identifying any or all such patent rights.

International Standard IEC 61968-8 has been prepared by IEC technical committee 57: Power systems management and associated information exchange.

The text of this standard is based on the following documents:

FDIS	Report on voting
57/1548/FDIS	57/1573/RVD

Full information on the voting for the approval of this standard can be found in the report on voting indicated in the above table.

This publication has been drafted in accordance with the ISO/IEC Directives, Part 2.

A list of all parts of the IEC 61968 series, under the general title: *Application integration at electric utilities – System interfaces for distribution management*, can be found on the IEC website.



The committee has decided that the contents of this publication will remain unchanged until the stability date indicated on the IEC web site under "<http://webstore.iec.ch>" in the data related to the specific publication. At this date, the publication will be

- reconfirmed,
- withdrawn,
- replaced by a revised edition, or
- amended.

A bilingual version of this publication may be issued at a later date.

**IMPORTANT – The 'colour inside' logo on the cover page of this publication indicates that it contains colours which are considered to be useful for the correct understanding of its contents. Users should therefore print this document using a colour printer.**

## INTRODUCTION

The purpose of this part of IEC 61968 is to define a standard for the integration of Customer Support (CS), which would include Customer Service, Trouble Management and Point of Sale related components integrated with other systems and business functions within the scope of IEC 61968. The scope of this standard is the exchange of information between a customer support system and other systems within the utility enterprise.

The IEC 61968 series of standards is intended to facilitate *inter-application integration* as opposed to intra-application integration. Intra-application integration is aimed at programs in the same application system, usually communicating with each other using middleware that is embedded in their underlying runtime environment, and tends to be optimised for close, real-time, synchronous connections and interactive request/reply or conversation communication models. IEC 61968, by contrast, is intended to support the inter-application integration of a utility enterprise that needs to connect disparate applications that are already built or new (legacy or purchased applications), each supported by dissimilar runtime environments. Therefore, these interface standards are relevant to loosely coupled applications with more heterogeneity in languages, operating systems, protocols and management tools. This series of standards is intended to support applications that need to exchange data every few seconds, minutes, or hours rather than waiting for a nightly batch run. This series of standards, which are intended to be implemented with middleware services that exchange messages among applications, will complement, not replace utility data warehouses, database gateways, and operational stores.

As used in IEC 61968, a Distribution Management System (DMS) consists of various distributed application components for the utility to manage electrical distribution networks. These capabilities include monitoring and control of equipment for power delivery, management processes to ensure system reliability, voltage management, demand-side management, outage management, work management, automated mapping and facilities management. Standard interfaces are defined for each class of applications identified in the Interface Reference Model (IRM), which is described in IEC 61968-1: *Application integration at electric utilities – System interfaces for distribution management – Interface Architecture and General Requirements*.

This part of IEC 61968 contains the clauses listed in Table 1.

**Table 1 – Document overview for IEC 61968-8**

Clause	Title	Purpose
1.	Scope	The scope and purpose of the document are described.
2.	Normative references	Documents that contain provisions which, through reference in this text, constitute provisions of this international standard.
3.	Terms, definitions and abbreviations	
4.	Reference and information models	Description of general approach to customer support, reference model, interface reference model, customer support functions and components, message type terms and static information model.
5.	Customer support message types	Message types related to the exchange of information for documents related to customer services.
Annex A	Sample XML schemas for message payloads	To provide XSD information for information use only.

# APPLICATION INTEGRATION AT ELECTRIC UTILITIES – SYSTEM INTERFACES FOR DISTRIBUTION MANAGEMENT –

## Part 8: Interfaces for customer operations

### 1 Scope

This part of IEC 61968 specifies the information content of a set of message types that can be used to support many of the business functions related to customer support. Typical uses of the message types include service request, customer agreement, and trouble management.

The purpose of this part of IEC 61968 is to define a standard for the integration of customer support (CS), which would include customer service, trouble management and point of sale related components integrated with other systems and business functions within the scope of IEC 61968. The scope of this standard is the exchange of information between a customer support system and other systems within the utility enterprise.

### 2 Normative references

The following documents, in whole or in part, are normatively referenced in this document and are indispensable for its application. For dated references, only the edition cited applies. For undated references, the latest edition of the referenced document (including any amendments) applies.

IEC 60050, *International Electrotechnical Vocabulary*

IEC 61968-1, *Application integration at electric utilities – System interfaces for distribution management – Part 1: Interface architecture and general recommendations*

IEC TS 61968-2, *Application integration at electric utilities – System interfaces for distribution management – Part 2: Glossary*

IEC 61968-6, *Application integration at electric utilities – System interfaces for distribution management – Part 6: Interfaces for maintenance and construction*<sup>1</sup>

IEC 61968-11, *Application integration at electric utilities – System interfaces for distribution management – Part 11: Common information model (CIM) extensions for distribution*

IEC 61968-100, *Application integration at electric utilities – System interfaces for distribution management – Part 100: Implementation profiles*

IEC 61970-301, *Energy management system application program interface (EMS-API) – Part 301: Common information model (CIM) base*

### 3 Terms, definitions and abbreviations

#### 3.1 Terms and definitions

For the purposes of this standard, the terms and definitions given in IEC 60050-300, IEC 61968-2, IEC 62051 and IEC 62055-31 apply.

Where there is a difference between the definitions in this standard and those contained in other referenced IEC standards, then those defined in IEC 61968-2 shall take precedence over the others listed, and those defined in this document shall take precedence over those defined in IEC 61968-2.

---

<sup>1</sup> To be published.

### 3.2 Abbreviations

CIM	Common information model
CIS	Customer information system
CRM	Customer relationship management
CSR	Customer service representative
ERT	Estimated restoration time
IVR	Interactive voice response
NO	Network operations
OMS	Outage management system
POS	Point of sale
UML	Unified modelling language
WM	Work management
XSD	XML schema definition

## 4 Reference and information models

### 4.1 Reference model

#### 4.1.1 General

The diagram in Figure 1 serves as a reference model and provides examples of the logical components and data flows related to the context of this part of IEC 61968.

Figure 1 describes the information flows between the components defined in this part of IEC 61968 and the components in the reference model defined in IEC 61968-1.

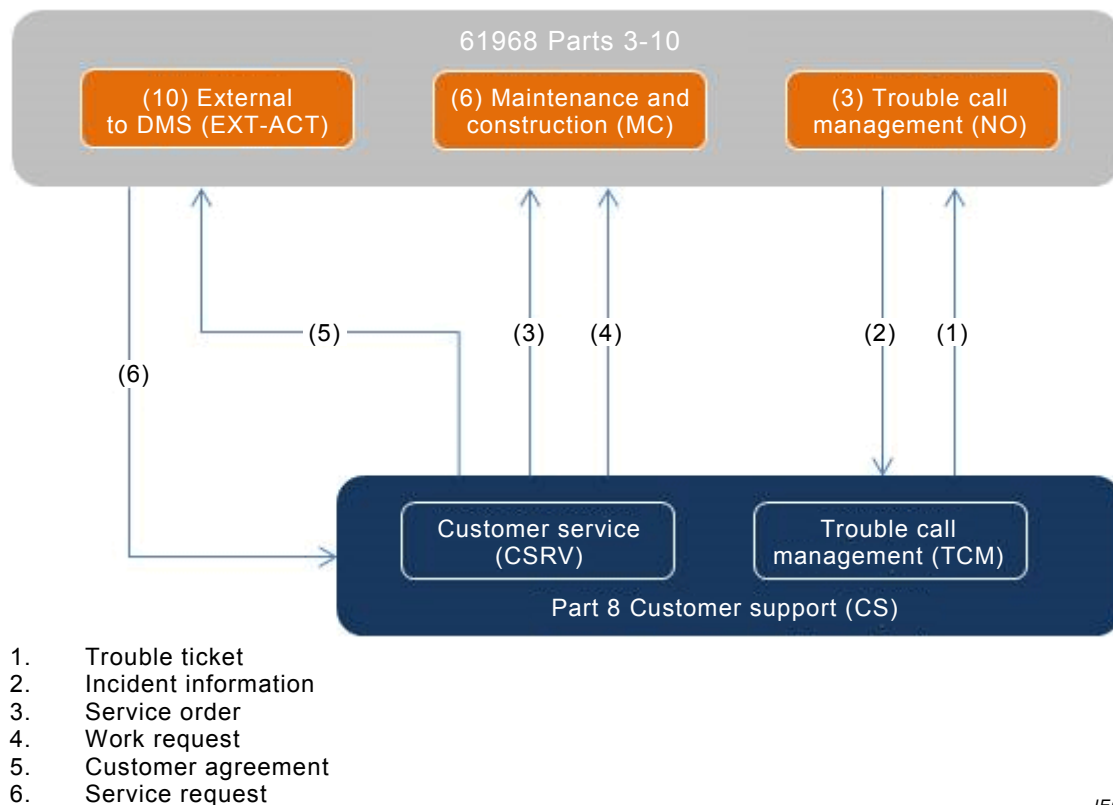

IEC

Figure 1 – IEC 61968-8 context model

#### 4.1.2 Customer support (CS)

Typical tasks of customer support:

- Customer services may include, but are not limited to, customer enquiries, new service, program enrollment and service or work request updates.
- Trouble call management may include, but are not limited to, trouble calls reported from customers and non-customers, outage notifications and restoration updates.

#### 4.2 Customer support functions and components

Table 2 shows these functions and typical abstract components that are expected to be producers of information for these message types. Typical consumers of the information include, but are not restricted to, the other components as listed in IEC 61968-1.

**Table 2 – Business functions and abstract components**

<b>Customer support (CS)</b>	Customer service (CSRV)	Service requests
		Construction billing inquiry
		Billing inquiry
		Work status
		Self-service inquiry
		Customer connection
		Turn on, turn off
		Line losses
		Service level agreements
		Customer information analysis
		Customer information management
		Customer relationship management
	Trouble call management (TCM)	Outage calls
		Power quality
		Planned outage notifications
		Media communication
		Performance indices
		Restoration projection/confirmation
	Point of sale (POS)	Outage history

#### 4.3 Static information model

##### 4.3.1 General

The information model relevant to customer support consists of classes that provide a template for the attributes for each message.

The classes are defined in detail in IEC 61968-11, *Application integration at electric utilities – System interfaces for distribution management – Part 11: Common Information Model (CIM) Extensions for Distribution* or in IEC 61970-301, *Energy management system application program interfaces (EMS-API) – Part 301: Common information model (CIM) base*.

##### 4.3.2 Classes for customer support

Table 3 lists classes used within message types. Usually all the attributes of these classes are contained within a message type. The descriptions provided describe usage within this part.

Classes described as type "Customer" are defined in the 61968/customer package of the CIM.

**Table 3 – Customer support classes**

Class/Noun	Package	Description
Customer	Customers	Organisation receiving services from service supplier
CustomerAgreement	Customers	Agreement between the customer and the service supplier to pay for service at a specific service location. It records certain billing information about the type of service provided at the service location and is used during charge creation to determine the type of service
DemandResponseProgram	Metering	Demand response program
Incident	Operations	Description of a problem in the field that may be reported in a trouble ticket or come from another source. It may have to do with an outage
Location	Common	The place, scene, or point of something where someone or something has been, is, and/or will be at a given moment in time. It can be defined with one or more position points (coordinates) in a given coordinate system
Outage	Operations	<p>Document describing details of an active or planned outage in a part of the electrical network.</p> <p>A non-planned outage may be created upon:</p> <ul style="list-style-type: none"> <li>– a breaker trip,</li> <li>– a fault indicator status change,</li> <li>– a meter event indicating customer outage,</li> <li>– a reception of one or more customer trouble calls, or</li> <li>– an operator command, reflecting information obtained from the field crew.</li> </ul> <p>Outage restoration may be performed using a switching plan which complements the outage information with detailed switching activities, including the relationship to the crew and work.</p> <p>A planned outage may be created upon:</p> <ul style="list-style-type: none"> <li>– a request for service, maintenance or construction work in the field, or</li> <li>– an operator-defined outage for what-if/contingency network analysis.</li> </ul> <p>The associated outage plan defines operational restrictions and atomic switch actions to define the changes that, after applied, would result in a total or partial equipment outage as required for network analysis.</p>
ServiceCategory	Customers	Category of service provided to the customer
ServiceLocation	Customers	A real estate location, commonly referred to as premise
TroubleTicket	Customers	A document that provides details about trouble in the power network
Work	Work	Document used to request, initiate, track and record work

NOTE The class definitions provided here are for convenience purposes only. The normative definitions are provided by IEC 61968-11, which describes the distribution extensions to the IEC CIM standard.

## 5 Customer support message types

### 5.1 General

The purpose of this section is to describe the message types related to IEC 61968-8. It is important to note that some of these message types may also be used by other parts of IEC 61968. The general approach to the realization of message structures and XML schemas for IEC 61968 messages is described in IEC 61968-1 and IEC 61968-100.

It is also important to note that the use cases and sequence diagrams provided in this standard are informative in nature, and are intended to provide examples of usage for the

normative messages definitions. There is no intent by this standard to standardize specific business processes.

## 5.2 Trouble ticket

### 5.2.1 General

Many electric utilities depend on the calls from the customers to begin the process to identify the location of the faulted section of the electric distribution circuit. The trouble ticket is the communication mechanism between the utility and the customer that is used to initiate an analysis to determine where best to deploy field personnel for service restoration. The trouble ticket is typically created based on direct conversation with the customer. The trouble ticket is also created based on customer report via an automated call taking system and on an outage report from an AMI meter. The trouble ticket contains the information of a customer call. Once created, the trouble ticket may be sent to the OMS for further processing.

Figure 2 provides a sequence diagram showing the use case for communication between the CIS and OMS using the trouble ticket message. Figure 3 presents an XSD diagram showing the contents of the trouble ticket message.

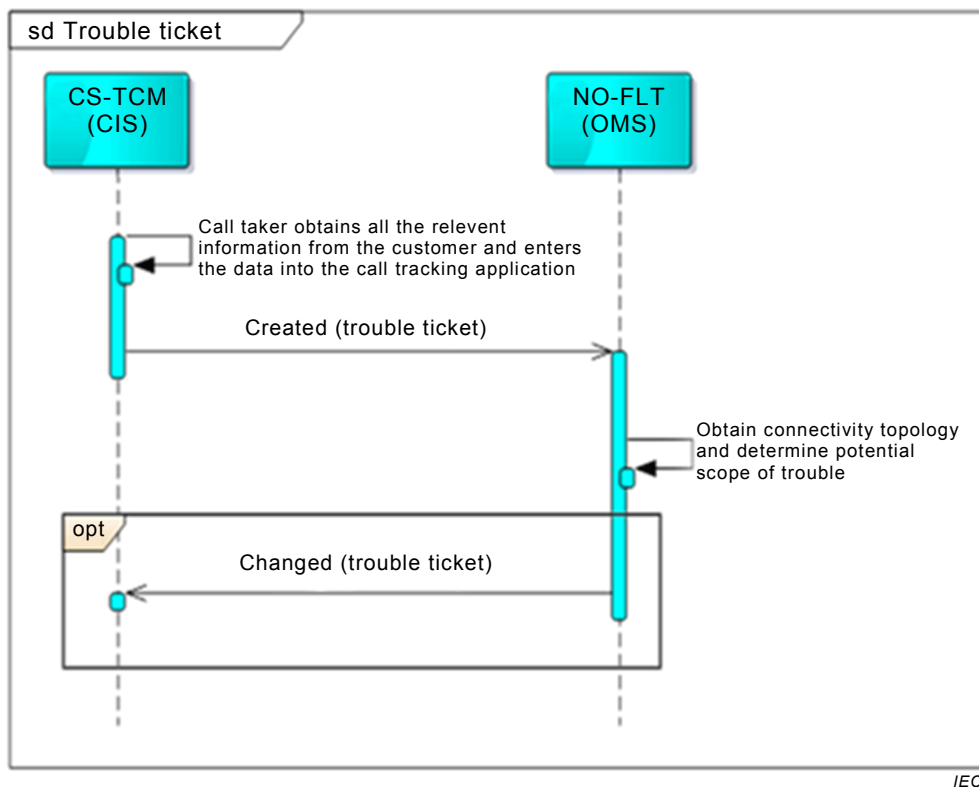

Figure 2 – Example of trouble ticket exchange between CIS and OMS

## 5.2.2 Message format

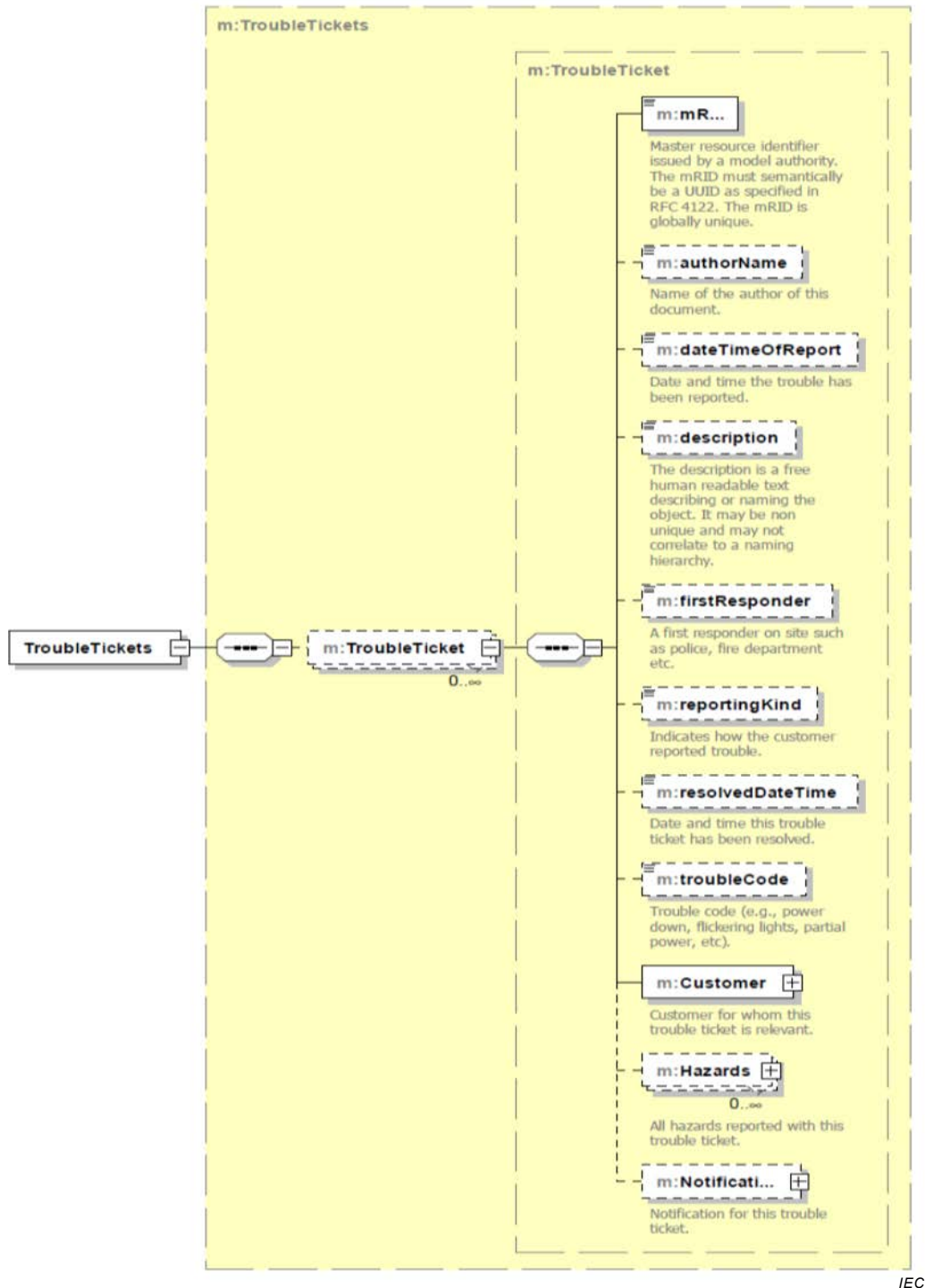

Figure 3 – Trouble ticket message

## 5.3 Incident information

### 5.3.1 General

When there is an outage and it is a confirmed outage, utilities typically can provide an estimated restoration time (ERT) depending on where the event is within the outage management processes. A request is made to outage management for a status update on a particular trouble ticket assigned to an outage incident, or to determine if an incident already exists before creating a trouble ticket (See Figure 4 showing the use case for this message exchange).



When making a trouble call, some callers request for a call back at a certain point in the restoration phase; e.g. at the time of arrival of the crew or when the supply is restored. This message needs to be created when the call back is due and lists the customers requiring call back. While the incident information message is generated by the Outage Management System (OMS), it is included in this document to complete the interaction between the CIS and the OMS and will be removed from this standard when the message is included in the IEC 61968-3. Figure 5 details the contents of the incident information message and includes the required elements of the CIS as well as the OMS.

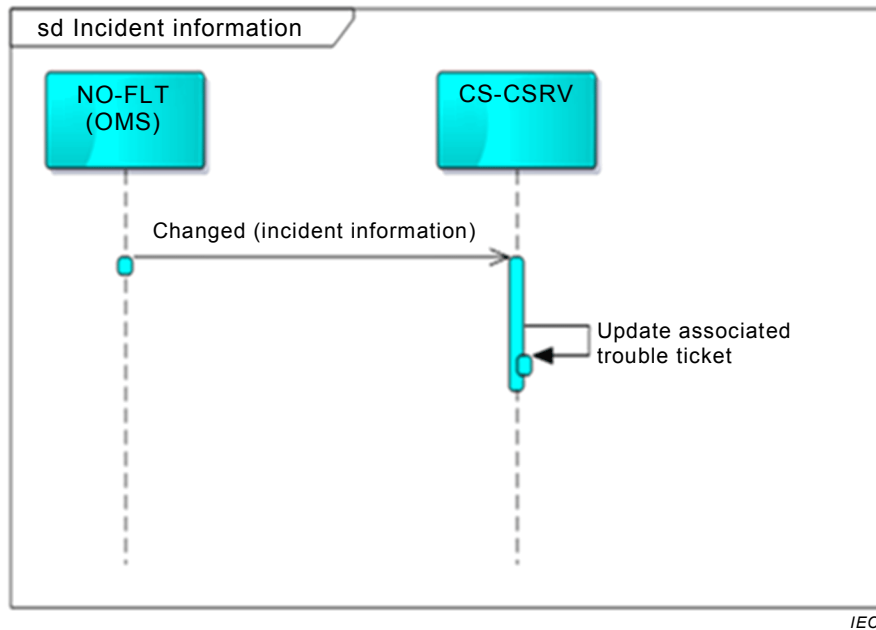

**Figure 4 – Example of incident information exchange between OMS and CIS**

5.3.2 Message format

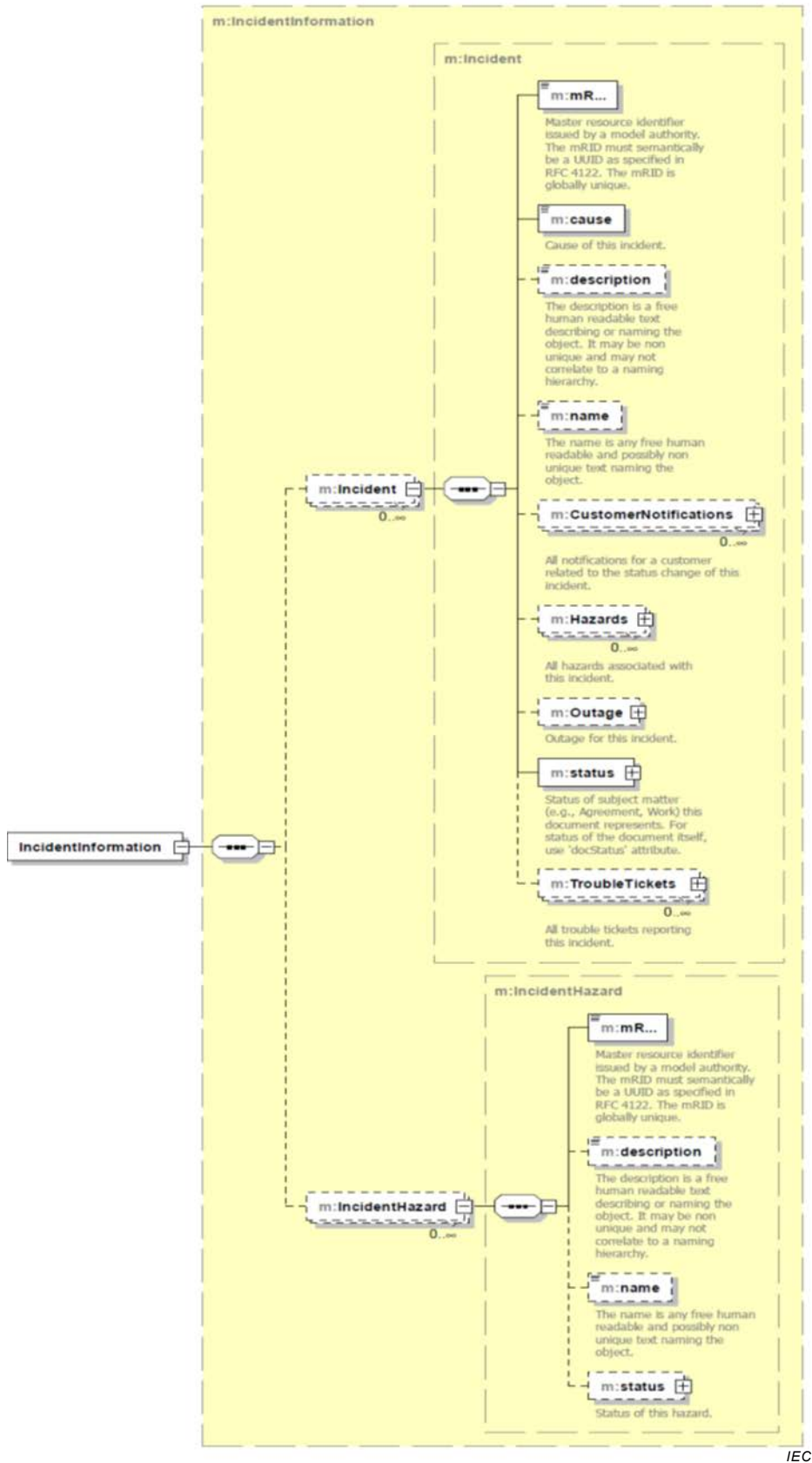

IEC

Figure 5 – Incident information message

## 5.4 Service request

### 5.4.1 General

Customers initiate service requests as their main point of contact with the utility. Service requests by a customer may include but are not limited to:

- Request to turn an existing service on or off (move in/move out, seasonal, etc.)
- Request a new service (electrification of a garage, new house, etc.)
- Request investigation into power quality or other concern about an existing service (not a trouble or outage call)
- Enroll or de-enroll in a customer program (demand response, etc.)
- Account issues (billing inquiries, high bill complaints, etc.)

Service requests may be initiated:

- In person at a utility office with a customer service representative (CSR)
- Over the internet to CIS or CRM systems
- Through an automated IVR system
- Over the telephone with a CSR

Once a service request is received, the CIS sends it to the WMS for further processing (see Figure 6).

Service requests may:

- Be manually handled by a customer service representative
- Cause a service order to be created and assigned to a field service technician/crew
- Cause a work request to be created in work management, which in turn may generate a work order or some other action

Service requests are typically handled by a manual process, but increasingly require an electronic representation between front end systems such as IVR and CRM, which send a service request message (see Figure 7 for message contents) to the customer information system.

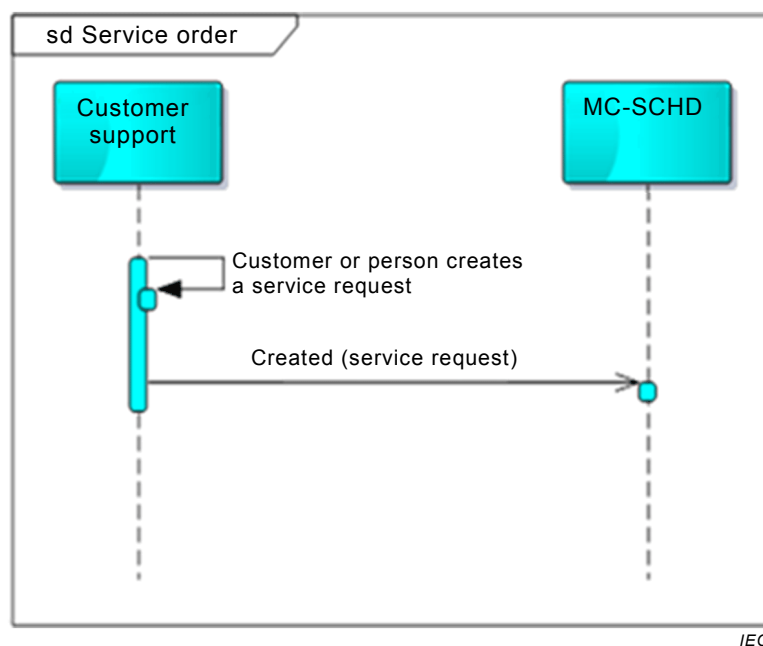
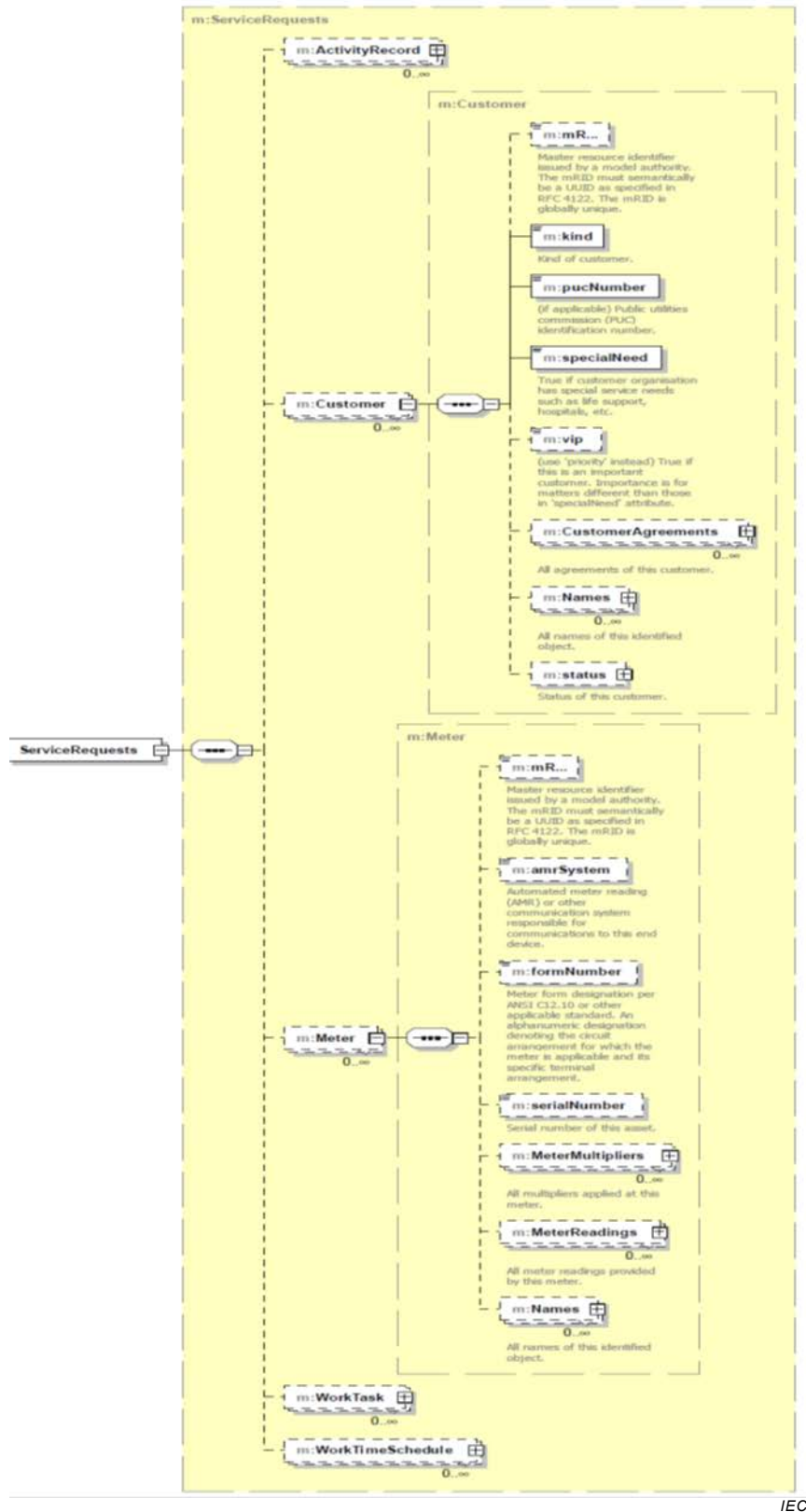

Figure 6 – Example of a service request exchange between CIS and WMS

5.4.2 Message format



IEC

Figure 7 – Service request message

## 5.5 Service order

### 5.5.1 General

A service order is an IEC 61968-6 message and is created when customer service needs to have some work done at a customer premise. The service order is created as one possible response to a service request.

The service order contains the information for a field service technician or crew to perform the work required by the customer such as:

- Service connection / disconnection
- Power quality / high bill investigation
- Meter service, such as meter replacement

Figure 8 shows the work flow between CIS and WMS when a service order message is exchanged.

Service orders by definition define work to be performed on an existing service and therefore typically include account and existing premise information. If a new service is required, a maintenance or construction order is required instead. The final task of a maintenance order for installing a new service is usually a meter set. This job is often performed by field service crews or technicians, so that meter set may occur as a service order, or as part of the maintenance order depending on the utility.

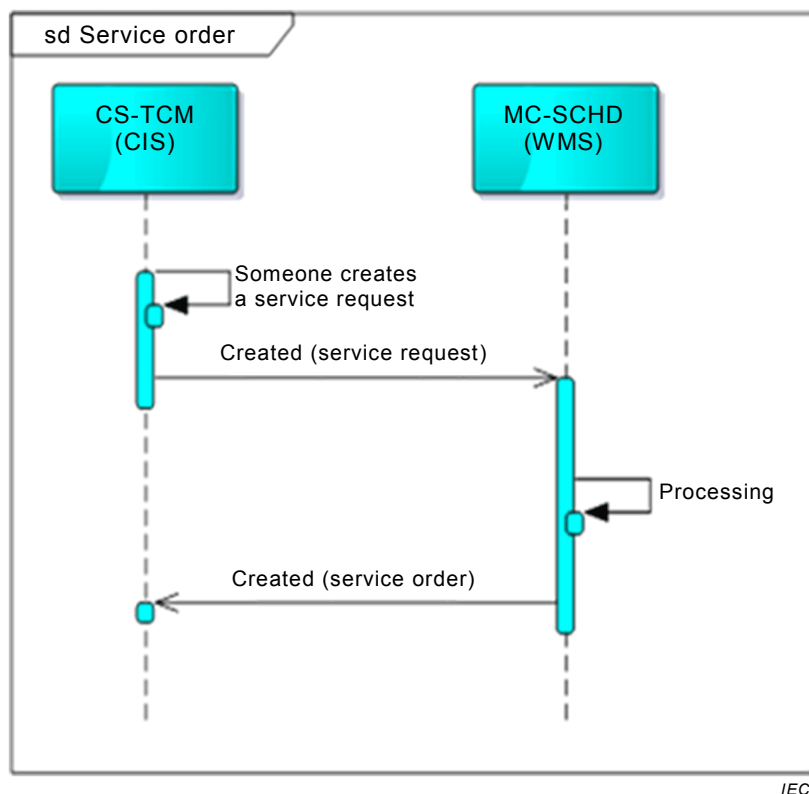

**Figure 8 – Example of a service order exchange between CIS and WMS**

The service order message is defined fully in IEC 61968-6.

## 5.6 Work request

### 5.6.1 General

A work request is an IEC 61968-6 message and informs work management that some work may be required on company assets. While there are numerous work management-initiated use cases for creating a work request, such as inspections and maintenance, this subclause describes work requests that are created by the customer support organization.

The work request is the main point of contact between the customer service organization and the engineering or maintenance organization. Figure 9 shows the work request message exchange between the CIS and WMS.

Typical reasons for customer service to create a work request include:

- A new customer wishes a new service to be created, such as when a new house is built
- An existing customer wishes to extend their service, such as adding power to previously unpowered garage
- An existing customer wishes to modify their service, such as upgrading from 100 A to 200 A service.

Engineering may create a maintenance order or construction order in the work management system to track the estimation, design, planning and eventually construction crew tasks to be performed in the field. Other utilities only create the maintenance or construction order when there is actual work to be done in the field.

Other processes that may cause the creation of maintenance or construction order include contribution in aid of construction or other evaluation.

Customers may end up declining to have the work done upon receipt of the estimate, and for many utilities that would mean that a maintenance or construction order never gets created in response to the work request.

The work request contains as much information as is needed for the eventual creation of a construction or maintenance order.

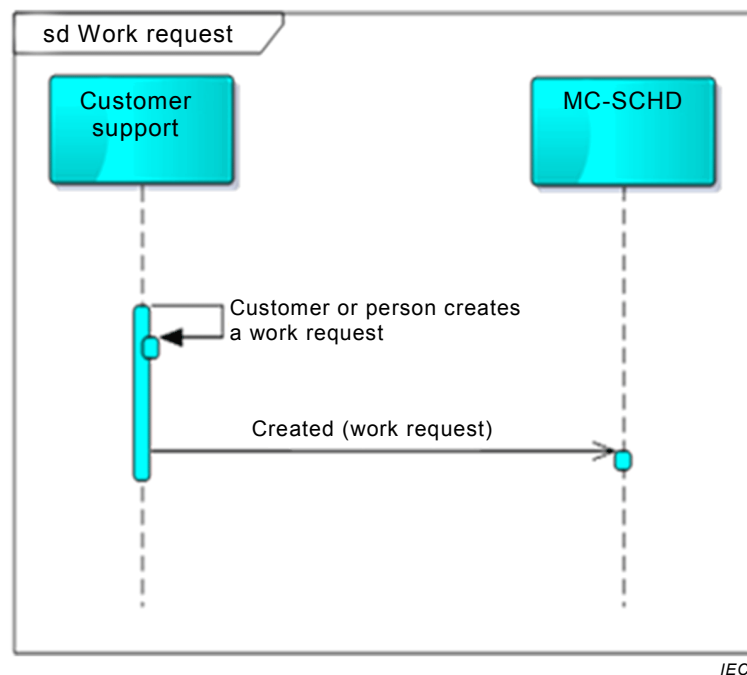

**Figure 9 – Example of a work request exchange between CIS and WMS**

The work request message is defined in IEC 61968-6 as well as the maintenance order and construction order messages.

## 5.7 Customer agreement

### 5.7.1 General

The customer service agreement documents the terms and conditions between the utility and the Customer for the provision of electricity. Not all utilities require a customer service agreement; however, utilities will assign the rate appropriate for the requested customer connection.

The customer agreement configuration message has been included in IEC 61968-9 because this Part 8 had not been published and the Automated Metering systems needed this message defined to fully define the exchanges with other back office systems. The GetCustomerAgreements is also contained in IEC 61968-9 and will remain there until the next release of this IS when it will be moved to IEC 61968-8. The CustomerAgreementConfig message that is currently contained in the 2<sup>nd</sup> edition of IEC 61968-9 will be removed in the next edition and will remain a part of IEC 61968-8.

Figure 10 provides a sequence diagram showing the use case for communication between the CIS and external or third party systems using the customer agreement message. Figure 11 presents an XSD diagram showing the contents of the customer agreement configuration message.

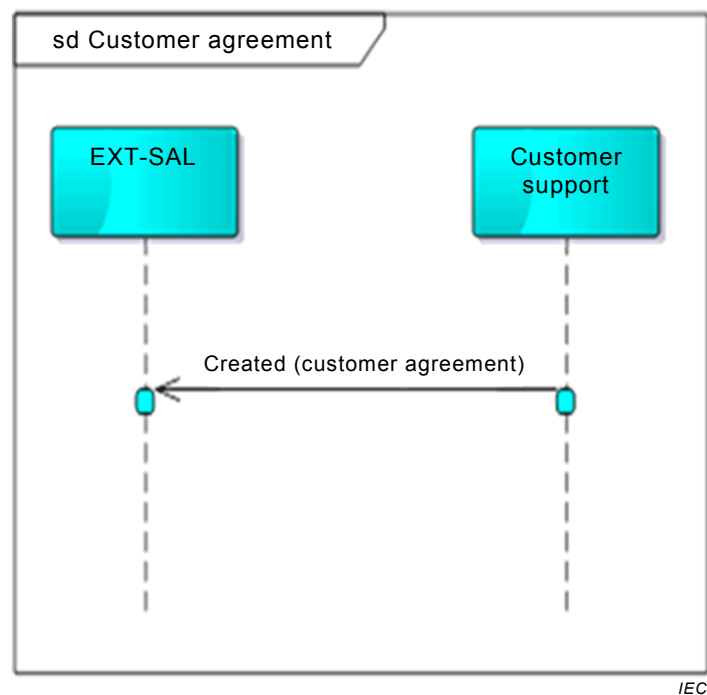

**Figure 10 – Example of a customer exchange between CIS and external or third party systems**

5.7.2 Message format

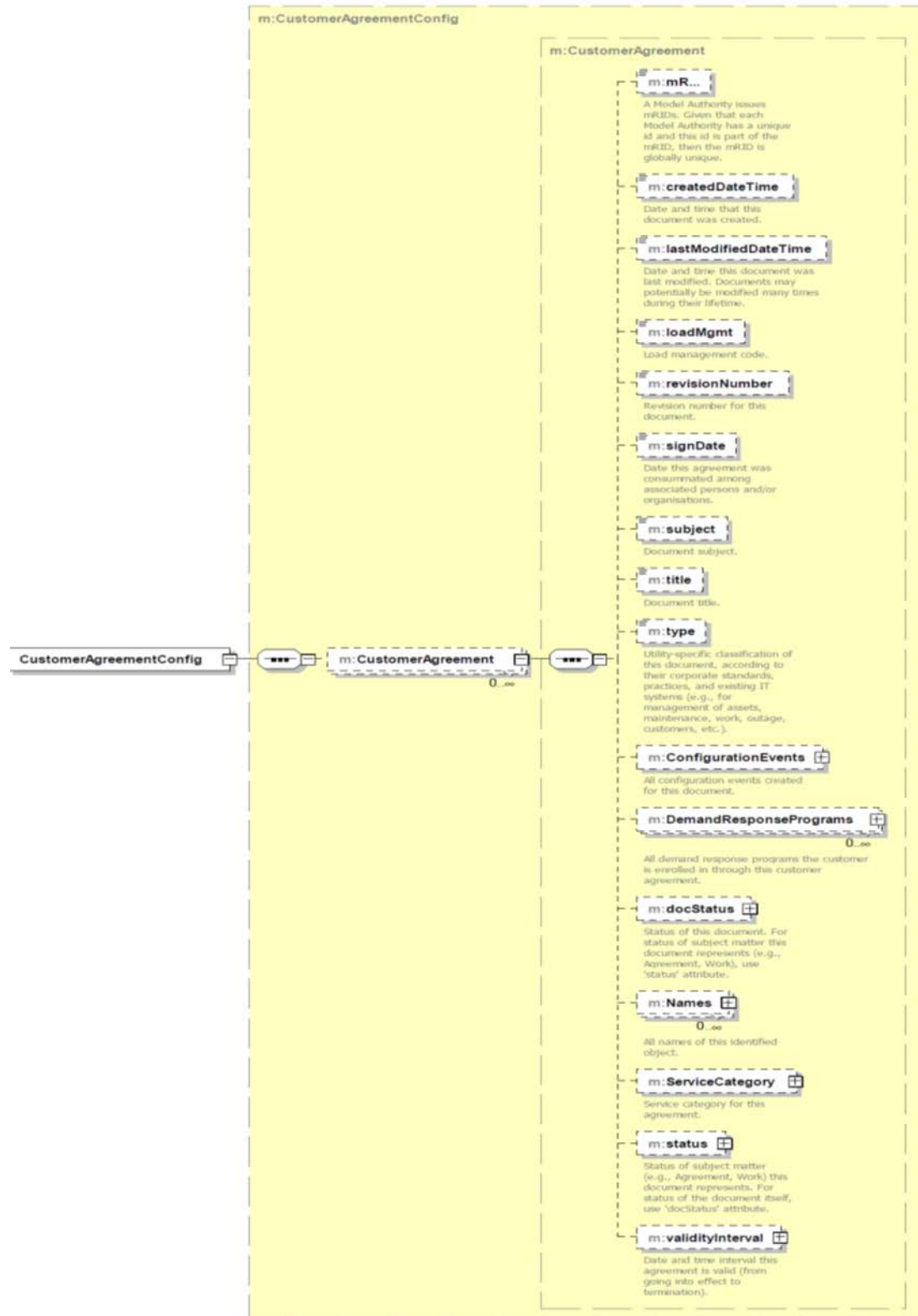

IEC

Figure 11 – Customer agreement message



## Annex A (normative)

### XML schemas for message payloads

The purpose of this annex is to provide examples of XML schemas (see Figure A.1, Figure A.2, Figure A.3 and Figure A.4) for message payloads to augment the descriptions provided earlier in this document. These XML Schemas were defined using profile definitions within CIMTool. These schemas may be extended as needed for specific implementation needs.

```

<?xml version="1.0" encoding="UTF-8"?>
<xs:schema xmlns:xs="http://www.w3.org/2001/XMLSchema" xmlns:a="http://langdale.com.au/2005/Message#"
xmlns:sawSDL="http://www.w3.org/ns/sawSDL" xmlns="http://langdale.com.au/2005/Message#"
xmlns:m="http://iec.ch/TC57/2014/TroubleTickets/1#" targetNamespace="http://iec.ch/TC57/2014/TroubleTickets/1#"
elementFormDefault="qualified" attributeFormDefault="unqualified">
  <xs:annotation>
    <xs:documentation/>
  </xs:annotation>
  <xs:element name="TroubleTickets" type="m:TroubleTickets"/>
  <xs:complexType name="TroubleTickets">
    <xs:sequence>
      <xs:element name="TroubleTicket" type="m:TroubleTicket" minOccurs="0"
maxOccurs="unbounded"/>
    </xs:sequence>
  </xs:complexType>
  <xs:complexType name="Customer" sawSDL:modelReference="http://iec.ch/TC57/CIM-generic#Customer">
    <xs:annotation>
      <xs:documentation>Organisation receiving services from service supplier.</xs:documentation>
    </xs:annotation>
    <xs:sequence>
      <xs:element name="mRID" type="xs:string" minOccurs="1" maxOccurs="1"
sawSDL:modelReference="http://iec.ch/TC57/CIM-generic#IdentifiedObject.mRID">
        <xs:annotation>
          <xs:documentation>Master resource identifier issued by a model authority.
The mRID must semantically be a UUID as specified in RFC 4122. The mRID is globally unique.</xs:documentation>
          <xs:documentation>For CIMXML data files in RDF syntax, the mRID is
mapped to rdf:ID or rdf:about attributes that identify CIM object elements.</xs:documentation>
        </xs:annotation>
      </xs:element>
    </xs:sequence>
  </xs:complexType>
  <xs:complexType name="CustomerNotification" sawSDL:modelReference="http://iec.ch/TC57/CIM-
generic#CustomerNotification">
    <xs:annotation>
      <xs:documentation>Conditions for notifying the customer about the changes in the status of their
service (e.g., outage restore, estimated restoration time, tariff or service level change, etc.)</xs:documentation>
    </xs:annotation>
    <xs:sequence>
      <xs:element name="contactType" type="xs:string" minOccurs="1" maxOccurs="1"
sawSDL:modelReference="http://iec.ch/TC57/CIM-generic#CustomerNotification.contactType">
        <xs:annotation>
          <xs:documentation>Type of contact (e.g., phone, email,
etc.)</xs:documentation>
        </xs:annotation>
      </xs:element>
      <xs:element name="contactValue" type="xs:string" minOccurs="1" maxOccurs="1"
sawSDL:modelReference="http://iec.ch/TC57/CIM-generic#CustomerNotification.contactValue">
        <xs:annotation>
          <xs:documentation>Value of contact type (e.g., phone number, email
address, etc.)</xs:documentation>
        </xs:annotation>
      </xs:element>
      <xs:element name="earliestDateTimeToCall" type="xs:dateTime" minOccurs="0" maxOccurs="1"
sawSDL:modelReference="http://iec.ch/TC57/CIM-generic#CustomerNotification.earliestDateTimeToCall">
        <xs:annotation>
          <xs:documentation>Earliest date time to call the
customer.</xs:documentation>
        </xs:annotation>
      </xs:element>
      <xs:element name="latestDateTimeToCall" type="xs:dateTime" minOccurs="0" maxOccurs="1"

```

```

sawSDL:modelReference="http://iec.ch/TC57/CIM-generic#CustomerNotification.latestDateTimeToCall">
  <xs:annotation>
    <xs:documentation>Latest date time to call the
customer.</xs:documentation>
  </xs:annotation>
</xs:element>
<xs:element name="trigger" type="m:NotificationTriggerKind" minOccurs="1" maxOccurs="1"
sawSDL:modelReference="http://iec.ch/TC57/CIM-generic#CustomerNotification.trigger">
  <xs:annotation>
    <xs:documentation>Trigger for this notification.</xs:documentation>
  </xs:annotation>
</xs:element>
</xs:sequence>
</xs:complexType>
<xs:complexType name="Incident" sawSDL:modelReference="http://iec.ch/TC57/CIM-generic#Incident">
  <xs:annotation>
    <xs:documentation>Description of a problem in the field that may be reported in a trouble ticket or
come from another source. It may have to do with an outage.</xs:documentation>
  </xs:annotation>
  <xs:sequence>
    <xs:element name="mRID" type="xs:string" minOccurs="0" maxOccurs="1"
sawSDL:modelReference="http://iec.ch/TC57/CIM-generic#IdentifiedObject.mRID">
      <xs:annotation>
        <xs:documentation>Master resource identifier issued by a model authority.
The mRID must semantically be a UUID as specified in RFC 4122. The mRID is globally unique.</xs:documentation>
        <xs:documentation>For CIMXML data files in RDF syntax, the mRID is
mapped to rdf:ID or rdf:about attributes that identify CIM object elements.</xs:documentation>
      </xs:annotation>
    </xs:element>
    <xs:element name="description" type="xs:string" minOccurs="0" maxOccurs="1"
sawSDL:modelReference="http://iec.ch/TC57/CIM-generic#IdentifiedObject.description">
      <xs:annotation>
        <xs:documentation>The description is a free human readable text describing
or naming the object. It may be non unique and may not correlate to a naming hierarchy.</xs:documentation>
      </xs:annotation>
    </xs:element>
    <xs:element name="name" type="xs:string" minOccurs="0" maxOccurs="1"
sawSDL:modelReference="http://iec.ch/TC57/CIM-generic#IdentifiedObject.name">
      <xs:annotation>
        <xs:documentation>The name is any free human readable and possibly non
unique text naming the object.</xs:documentation>
      </xs:annotation>
    </xs:element>
  </xs:sequence>
</xs:complexType>
<xs:complexType name="IncidentHazard" sawSDL:modelReference="http://iec.ch/TC57/CIM-
generic#IncidentHazard">
  <xs:annotation>
    <xs:documentation>Hazardous situation associated with an incident. Examples are line down,
gas leak, fire, etc.</xs:documentation>
  </xs:annotation>
  <xs:sequence>
    <xs:element name="mRID" type="xs:string" minOccurs="1" maxOccurs="1"
sawSDL:modelReference="http://iec.ch/TC57/CIM-generic#IdentifiedObject.mRID">
      <xs:annotation>
        <xs:documentation>Master resource identifier issued by a model authority.
The mRID must semantically be a UUID as specified in RFC 4122. The mRID is globally unique.</xs:documentation>
        <xs:documentation>For CIMXML data files in RDF syntax, the mRID is
mapped to rdf:ID or rdf:about attributes that identify CIM object elements.</xs:documentation>
      </xs:annotation>
    </xs:element>
  </xs:sequence>
</xs:complexType>
<xs:simpleType name="NotificationTriggerKind" sawSDL:modelReference="http://iec.ch/TC57/CIM-
generic#NotificationTriggerKind">
  <xs:annotation>
    <xs:documentation>Kind of trigger to notify customer.</xs:documentation>
  </xs:annotation>
  <xs:restriction base="xs:string">
    <xs:enumeration value="etrChange">
      <xs:annotation>
        <xs:documentation>Notify customer if estimated restoration time
changes.</xs:documentation>
      </xs:annotation>
    </xs:enumeration>
    <xs:enumeration value="informDispatched">
      <xs:annotation>
    </xs:annotation>
  </xs:restriction>
</xs:simpleType>

```

```

investigate the problem.</xs:documentation>
    <xs:documentation>Notify customer that a crew has been dispatched to
    </xs:documentation>
    </xs:annotation>
  </xs:enumeration>
  <xs:enumeration value="initialEtr">
    <xs:annotation>
      <xs:documentation>Notify customer for the first time that estimated
restoration time is available.</xs:documentation>
    </xs:annotation>
  </xs:enumeration>
  <xs:enumeration value="powerOut">
    <xs:annotation>
      <xs:documentation>Notify customer of planned outage.</xs:documentation>
    </xs:annotation>
  </xs:enumeration>
  <xs:enumeration value="powerRestored">
    <xs:annotation>
      <xs:documentation>Notify customer when power has been
restored.</xs:documentation>
    </xs:annotation>
  </xs:enumeration>
</xs:restriction>
</xs:simpleType>
<xs:simpleType name="TroubleReportingKind" sawsdl:modelReference="http://iec.ch/TC57/CIM-
generic#TroubleReportingKind">
  <xs:annotation>
    <xs:documentation>Kind of trouble reporting.</xs:documentation>
  </xs:annotation>
  <xs:restriction base="xs:string">
    <xs:enumeration value="call">
      <xs:annotation>
        <xs:documentation>Trouble call received by customer service
representative.</xs:documentation>
      </xs:annotation>
    </xs:enumeration>
    <xs:enumeration value="email">
      <xs:annotation>
        <xs:documentation>Trouble reported by email.</xs:documentation>
      </xs:annotation>
    </xs:enumeration>
    <xs:enumeration value="ivr">
      <xs:annotation>
        <xs:documentation>Trouble reported through interactive voice response
system.</xs:documentation>
      </xs:annotation>
    </xs:enumeration>
    <xs:enumeration value="letter">
      <xs:annotation>
        <xs:documentation>Trouble reported by letter.</xs:documentation>
      </xs:annotation>
    </xs:enumeration>
    <xs:enumeration value="other">
      <xs:annotation>
        <xs:documentation>Trouble reported by other means.</xs:documentation>
      </xs:annotation>
    </xs:enumeration>
  </xs:restriction>
</xs:simpleType>
<xs:complexType name="TroubleTicket" sawsdl:modelReference="http://iec.ch/TC57/CIM-generic#TroubleTicket">
  <xs:annotation/>
  <xs:sequence>
    <xs:element name="mRID" type="xs:string" minOccurs="1" maxOccurs="1"
sawsdl:modelReference="http://iec.ch/TC57/CIM-generic#IdentifiedObject.mRID">
      <xs:annotation>
        <xs:documentation>Master resource identifier issued by a model authority.
The mRID must semantically be a UUID as specified in RFC 4122. The mRID is globally unique.</xs:documentation>
      </xs:annotation>
      <xs:documentation>For CIMXML data files in RDF syntax, the mRID is
mapped to rdf:ID or rdf:about attributes that identify CIM object elements.</xs:documentation>
    </xs:element>
    <xs:element name="authorName" type="xs:string" minOccurs="0" maxOccurs="1"
sawsdl:modelReference="http://iec.ch/TC57/CIM-generic#Document.authorName">
      <xs:annotation>
        <xs:documentation>Name of the author of this
document.</xs:documentation>
      </xs:annotation>
    </xs:element>
  </xs:sequence>
</xs:complexType>
</xs:element>

```

```

        <xs:element name="dateTimeOfReport" type="xs:dateTime" minOccurs="0" maxOccurs="1"
sawSDL:modelReference="http://iec.ch/TC57/CIM-generic#TroubleTicket.dateTimeOfReport">
            <xs:annotation>
                <xs:documentation>Date and time the trouble has been
reported.</xs:documentation>
            </xs:annotation>
        </xs:element>
        <xs:element name="description" type="xs:string" minOccurs="0" maxOccurs="1"
sawSDL:modelReference="http://iec.ch/TC57/CIM-generic#IdentifiedObject.description">
            <xs:annotation>
                <xs:documentation>The description is a free human readable text describing
or naming the object. It may be non unique and may not correlate to a naming hierarchy.</xs:documentation>
            </xs:annotation>
        </xs:element>
        <xs:element name="firstResponder" type="xs:string" minOccurs="0" maxOccurs="1"
sawSDL:modelReference="http://iec.ch/TC57/CIM-generic#TroubleTicket.firstResponder">
            <xs:annotation>
                <xs:documentation>A first responder on site such as police, fire department
etc.</xs:documentation>
            </xs:annotation>
        </xs:element>
        <xs:element name="reportingKind" type="m:TroubleReportingKind" minOccurs="0"
maxOccurs="1" sawSDL:modelReference="http://iec.ch/TC57/CIM-generic#TroubleTicket.reportingKind">
            <xs:annotation>
                <xs:documentation>Indicates how the customer reported
trouble.</xs:documentation>
            </xs:annotation>
        </xs:element>
        <xs:element name="resolvedDateTime" type="xs:dateTime" minOccurs="0" maxOccurs="1"
sawSDL:modelReference="http://iec.ch/TC57/CIM-generic#TroubleTicket.resolvedDateTime">
            <xs:annotation>
                <xs:documentation>Date and time this trouble ticket has been
resolved.</xs:documentation>
            </xs:annotation>
        </xs:element>
        <xs:element name="troubleCode" type="xs:string" minOccurs="0" maxOccurs="1"
sawSDL:modelReference="http://iec.ch/TC57/CIM-generic#TroubleTicket.troubleCode">
            <xs:annotation>
                <xs:documentation>Trouble code (e.g., power down, flickering lights, partial
power, etc).</xs:documentation>
            </xs:annotation>
        </xs:element>
        <xs:element name="Customer" type="m:Customer" minOccurs="1" maxOccurs="1"
sawSDL:modelReference="http://iec.ch/TC57/CIM-generic#TroubleTicket.Customer">
            <xs:annotation>
                <xs:documentation>Customer for whom this trouble ticket is
relevant.</xs:documentation>
            </xs:annotation>
        </xs:element>
        <xs:element name="Hazards" type="m:IncidentHazard" minOccurs="0" maxOccurs="unbounded"
sawSDL:modelReference="http://iec.ch/TC57/CIM-generic#TroubleTicket.Hazards">
            <xs:annotation>
                <xs:documentation>All hazards reported with this trouble
ticket.</xs:documentation>
            </xs:annotation>
        </xs:element>
        <xs:element name="Notification" type="m:CustomerNotification" minOccurs="0" maxOccurs="1"
sawSDL:modelReference="http://iec.ch/TC57/CIM-generic#TroubleTicket.Notification">
            <xs:annotation>
                <xs:documentation>Notification for this trouble ticket.</xs:documentation>
            </xs:annotation>
        </xs:element>
    </xs:sequence>
</xs:complexType>
</xs:schema>

```

Figure A.1 – Trouble ticket XSD

```

<?xml version="1.0" encoding="UTF-8"?>
<xs:schema xmlns:xs="http://www.w3.org/2001/XMLSchema" xmlns:a="http://langdale.com.au/2005/Message#"
xmlns:sawsdl="http://www.w3.org/ns/sawsdl" xmlns="http://langdale.com.au/2005/Message#"
xmlns:m="http://iec.ch/TC57/2014/IncidentInformation/1#" targetNamespace="http://iec.ch/TC57/2014/IncidentInformation/1#"
elementFormDefault="qualified" attributeFormDefault="unqualified">
  <xs:annotation>
    <xs:documentation/>
  </xs:annotation>
  <xs:element name="IncidentInformation" type="m:IncidentInformation"/>
  <xs:complexType name="IncidentInformation">
    <xs:sequence>
      <xs:element name="Incident" type="m:Incident" minOccurs="0" maxOccurs="unbounded"/>
      <xs:element name="IncidentHazard" type="m:IncidentHazard" minOccurs="0"
maxOccurs="unbounded"/>
    </xs:sequence>
  </xs:complexType>
  <xs:complexType name="CustomerNotification" sawsdl:modelReference="http://iec.ch/TC57/CIM-
generic#CustomerNotification">
    <xs:annotation>
      <xs:documentation>Conditions for notifying the customer about the changes in the status of their
service (e.g., outage restore, estimated restoration time, tariff or service level change, etc.)</xs:documentation>
    </xs:annotation>
    <xs:sequence>
      <xs:element name="contactType" type="xs:string" minOccurs="1" maxOccurs="1"
sawsdl:modelReference="http://iec.ch/TC57/CIM-generic#CustomerNotification.contactType">
        <xs:annotation>
          <xs:documentation>Type of contact (e.g., phone, email,
etc.)</xs:documentation>
        </xs:annotation>
      </xs:element>
      <xs:element name="contactValue" type="xs:string" minOccurs="1" maxOccurs="1"
sawsdl:modelReference="http://iec.ch/TC57/CIM-generic#CustomerNotification.contactValue">
        <xs:annotation>
          <xs:documentation>Value of contact type (e.g., phone number, email
address, etc.)</xs:documentation>
        </xs:annotation>
      </xs:element>
      <xs:element name="earliestDateTimeToCall" type="xs:dateTime" minOccurs="1" maxOccurs="1"
sawsdl:modelReference="http://iec.ch/TC57/CIM-generic#CustomerNotification.earliestDateTimeToCall">
        <xs:annotation>
          <xs:documentation>Earliest date time to call the
customer.</xs:documentation>
        </xs:annotation>
      </xs:element>
      <xs:element name="latestDateTimeToCall" type="xs:dateTime" minOccurs="1" maxOccurs="1"
sawsdl:modelReference="http://iec.ch/TC57/CIM-generic#CustomerNotification.latestDateTimeToCall">
        <xs:annotation>
          <xs:documentation>Latest date time to call the
customer.</xs:documentation>
        </xs:annotation>
      </xs:element>
      <xs:element name="trigger" type="m:NotificationTriggerKind" minOccurs="1" maxOccurs="1"
sawsdl:modelReference="http://iec.ch/TC57/CIM-generic#CustomerNotification.trigger">
        <xs:annotation>
          <xs:documentation>Trigger for this notification.</xs:documentation>
        </xs:annotation>
      </xs:element>
    </xs:sequence>
  </xs:complexType>
  <xs:complexType name="Incident" sawsdl:modelReference="http://iec.ch/TC57/CIM-generic#Incident">
    <xs:annotation>
      <xs:documentation>Description of a problem in the field that may be reported in a trouble ticket or
come from another source. It may have to do with an outage.</xs:documentation>
    </xs:annotation>
    <xs:sequence>
      <xs:element name="mRID" type="xs:string" minOccurs="1" maxOccurs="1"
sawsdl:modelReference="http://iec.ch/TC57/CIM-generic#IdentifiedObject.mRID">
        <xs:annotation>
          <xs:documentation>Master resource identifier issued by a model authority.
The mRID must semantically be a UUID as specified in RFC 4122. The mRID is globally unique.</xs:documentation>
          <xs:documentation>For CIMXML data files in RDF syntax, the mRID is
mapped to rdf:ID or rdf:about attributes that identify CIM object elements.</xs:documentation>
        </xs:annotation>
      </xs:element>
      <xs:element name="cause" type="xs:string" minOccurs="1" maxOccurs="1"
sawsdl:modelReference="http://iec.ch/TC57/CIM-generic#Incident.cause">
        <xs:annotation>

```

```

                <xs:documentation>Cause of this incident.</xs:documentation>
            </xs:annotation>
        </xs:element>
        <xs:element name="description" type="xs:string" minOccurs="0" maxOccurs="1"
sawSDL:modelReference="http://iec.ch/TC57/CIM-generic#IdentifiedObject.description">
            <xs:annotation>
                <xs:documentation>The description is a free human readable text describing
or naming the object. It may be non unique and may not correlate to a naming hierarchy.</xs:documentation>
            </xs:annotation>
        </xs:element>
        <xs:element name="name" type="xs:string" minOccurs="0" maxOccurs="1"
sawSDL:modelReference="http://iec.ch/TC57/CIM-generic#IdentifiedObject.name">
            <xs:annotation>
                <xs:documentation>The name is any free human readable and possibly non
unique text naming the object.</xs:documentation>
            </xs:annotation>
        </xs:element>
        <xs:element name="CustomerNotifications" type="m:CustomerNotification" minOccurs="0"
maxOccurs="unbounded" sawSDL:modelReference="http://iec.ch/TC57/CIM-generic#Incident.CustomerNotifications">
            <xs:annotation>
                <xs:documentation>All notifications for a customer related to the status
change of this incident.</xs:documentation>
            </xs:annotation>
        </xs:element>
        <xs:element name="Hazards" minOccurs="0" maxOccurs="unbounded"
sawSDL:modelReference="http://iec.ch/TC57/CIM-generic#Incident.Hazards">
            <xs:annotation>
                <xs:documentation>All hazards associated with this
incident.</xs:documentation>
            </xs:annotation>
            <xs:complexType sawSDL:modelReference="http://iec.ch/TC57/CIM-
generic#IncidentHazard">
                <xs:attribute name="ref" type="xs:string"/>
            </xs:complexType>
        </xs:element>
        <xs:element name="Outage" type="m:Outage" minOccurs="0" maxOccurs="1"
sawSDL:modelReference="http://iec.ch/TC57/CIM-generic#Incident.Outage">
            <xs:annotation>
                <xs:documentation>Outage for this incident.</xs:documentation>
            </xs:annotation>
        </xs:element>
        <xs:element name="status" type="m:Status" minOccurs="1" maxOccurs="1"
sawSDL:modelReference="http://iec.ch/TC57/CIM-generic#Document.status">
            <xs:annotation>
                <xs:documentation>Status of subject matter (e.g., Agreement, Work) this
document represents. For status of the document itself, use 'docStatus' attribute.</xs:documentation>
            </xs:annotation>
        </xs:element>
        <xs:element name="TroubleTickets" type="m:TroubleTicket" minOccurs="0"
maxOccurs="unbounded" sawSDL:modelReference="http://iec.ch/TC57/CIM-generic#Incident.TroubleTickets">
            <xs:annotation>
                <xs:documentation>All trouble tickets reporting this
incident.</xs:documentation>
            </xs:annotation>
        </xs:element>
    </xs:sequence>
</xs:complexType>
<xs:complexType name="IncidentHazard" sawSDL:modelReference="http://iec.ch/TC57/CIM-
generic#IncidentHazard">
    <xs:annotation>
        <xs:documentation>Hazardous situation associated with an incident. Examples are line down,
gas leak, fire, etc.</xs:documentation>
    </xs:annotation>
    <xs:sequence>
        <xs:element name="mRID" type="xs:string" minOccurs="1" maxOccurs="1"
sawSDL:modelReference="http://iec.ch/TC57/CIM-generic#IdentifiedObject.mRID">
            <xs:annotation>
                <xs:documentation>Master resource identifier issued by a model authority.
The mRID must semantically be a UUID as specified in RFC 4122. The mRID is globally unique.</xs:documentation>
                <xs:documentation>For CIMXML data files in RDF syntax, the mRID is
mapped to rdf:ID or rdf:about attributes that identify CIM object elements.</xs:documentation>
            </xs:annotation>
        </xs:element>
        <xs:element name="description" type="xs:string" minOccurs="0" maxOccurs="1"
sawSDL:modelReference="http://iec.ch/TC57/CIM-generic#IdentifiedObject.description">
            <xs:annotation>
                <xs:documentation>The description is a free human readable text describing

```



```

or naming the object. It may be non unique and may not correlate to a naming hierarchy.</xs:documentation>
    </xs:annotation>
  </xs:element>
  <xs:element name="name" type="xs:string" minOccurs="0" maxOccurs="1"
sawSDL:modelReference="http://iec.ch/TC57/CIM-generic#IdentifiedObject.name">
    <xs:annotation>
      <xs:documentation>The name is any free human readable and possibly non
unique text naming the object.</xs:documentation>
    </xs:annotation>
  </xs:element>
  <xs:element name="status" type="m:Status" minOccurs="0" maxOccurs="1"
sawSDL:modelReference="http://iec.ch/TC57/CIM-generic#Hazard.status">
    <xs:annotation>
      <xs:documentation>Status of this hazard.</xs:documentation>
    </xs:annotation>
  </xs:element>
</xs:sequence>
</xs:complexType>
<xs:simpleType name="NotificationTriggerKind" sawSDL:modelReference="http://iec.ch/TC57/CIM-
generic#NotificationTriggerKind">
  <xs:annotation>
    <xs:documentation>Kind of trigger to notify customer.</xs:documentation>
  </xs:annotation>
  <xs:restriction base="xs:string">
    <xs:enumeration value="etrChange">
      <xs:annotation>
        <xs:documentation>Notify customer if estimated restoration time
changes.</xs:documentation>
      </xs:annotation>
    </xs:enumeration>
    <xs:enumeration value="informDispatched">
      <xs:annotation>
        <xs:documentation>Notify customer that a crew has been dispatched to
investigate the problem.</xs:documentation>
      </xs:annotation>
    </xs:enumeration>
    <xs:enumeration value="initialEtr">
      <xs:annotation>
        <xs:documentation>Notify customer for the first time that estimated
restoration time is available.</xs:documentation>
      </xs:annotation>
    </xs:enumeration>
    <xs:enumeration value="powerOut">
      <xs:annotation>
        <xs:documentation>Notify customer of planned outage.</xs:documentation>
      </xs:annotation>
    </xs:enumeration>
    <xs:enumeration value="powerRestored">
      <xs:annotation>
        <xs:documentation>Notify customer when power has been
restored.</xs:documentation>
      </xs:annotation>
    </xs:enumeration>
  </xs:restriction>
</xs:simpleType>
<xs:complexType name="Outage" sawSDL:modelReference="http://iec.ch/TC57/CIM-generic#Outage">
  <xs:annotation>
    <xs:documentation>Document describing details of an active or planned outage in a part of the
electrical network.</xs:documentation>
    <xs:documentation>A non-planned outage may be created upon:</xs:documentation>
    <xs:documentation>- a breaker trip,</xs:documentation>
    <xs:documentation>- a fault indicator status change,</xs:documentation>
    <xs:documentation>- a meter event indicating customer outage,</xs:documentation>
    <xs:documentation>- a reception of one or more customer trouble calls, or</xs:documentation>
    <xs:documentation>- an operator command, reflecting information obtained from the field
crew.</xs:documentation>
    <xs:documentation>Outage restoration may be performed using a switching plan which
complements the outage information with detailed switching activities, including the relationship to the crew and
work.</xs:documentation>
    <xs:documentation>A planned outage may be created upon:</xs:documentation>
    <xs:documentation>- a request for service, maintenance or construction work in the field,
or</xs:documentation>
    <xs:documentation>- an operator-defined outage for what-if/contingency network
analysis.</xs:documentation>
  </xs:annotation>
</xs:sequence>
  <xs:element name="mRID" type="xs:string" minOccurs="1" maxOccurs="1"

```

```

sawSDL:modelReference="http://iec.ch/TC57/CIM-generic#IdentifiedObject.mRID">
  <xs:annotation>
    <xs:documentation>Master resource identifier issued by a model authority.
The mRID must semantically be a UUID as specified in RFC 4122. The mRID is globally unique.</xs:documentation>
    <xs:documentation>For CIMXML data files in RDF syntax, the mRID is
mapped to rdf:ID or rdf:about attributes that identify CIM object elements.</xs:documentation>
  </xs:annotation>
</xs:element>
</xs:sequence>
</xs:complexType>
<xs:complexType name="Status" sawSDL:modelReference="http://iec.ch/TC57/CIM-generic#Status">
  <xs:annotation>
    <xs:documentation>Current status information relevant to an entity.</xs:documentation>
  </xs:annotation>
  <xs:sequence>
    <xs:element name="dateTime" type="xs:dateTime" minOccurs="1" maxOccurs="1"
sawSDL:modelReference="http://iec.ch/TC57/CIM-generic#Status.dateTime">
      <xs:annotation>
        <xs:documentation>Date and time for which status 'value'
applies.</xs:documentation>
      </xs:annotation>
    </xs:element>
    <xs:element name="reason" type="xs:string" minOccurs="0" maxOccurs="1"
sawSDL:modelReference="http://iec.ch/TC57/CIM-generic#Status.reason">
      <xs:annotation>
        <xs:documentation>Reason code or explanation for why an object went to
the current status 'value'.</xs:documentation>
      </xs:annotation>
    </xs:element>
    <xs:element name="remark" type="xs:string" minOccurs="0" maxOccurs="1"
sawSDL:modelReference="http://iec.ch/TC57/CIM-generic#Status.remark">
      <xs:annotation>
        <xs:documentation>Pertinent information regarding the current 'value', as
free form text.</xs:documentation>
      </xs:annotation>
    </xs:element>
    <xs:element name="value" type="xs:string" minOccurs="1" maxOccurs="1"
sawSDL:modelReference="http://iec.ch/TC57/CIM-generic#Status.value">
      <xs:annotation>
        <xs:documentation>Status value at 'dateTime'; prior status changes may
have been kept in instances of activity records associated with the object to which this status applies.</xs:documentation>
      </xs:annotation>
    </xs:element>
  </xs:sequence>
</xs:complexType>
<xs:complexType name="TroubleTicket" sawSDL:modelReference="http://iec.ch/TC57/CIM-generic#TroubleTicket">
  <xs:annotation/>
  <xs:sequence>
    <xs:element name="mRID" type="xs:string" minOccurs="1" maxOccurs="1"
sawSDL:modelReference="http://iec.ch/TC57/CIM-generic#IdentifiedObject.mRID">
      <xs:annotation>
        <xs:documentation>Master resource identifier issued by a model authority.
The mRID must semantically be a UUID as specified in RFC 4122. The mRID is globally unique.</xs:documentation>
        <xs:documentation>For CIMXML data files in RDF syntax, the mRID is
mapped to rdf:ID or rdf:about attributes that identify CIM object elements.</xs:documentation>
      </xs:annotation>
    </xs:element>
  </xs:sequence>
</xs:complexType>
</xs:schema>

```

Figure A.2 – Incident information XSD



```

<?xml version="1.0" encoding="UTF-8"?>
<xs:schema xmlns:xs="http://www.w3.org/2001/XMLSchema" xmlns:a="http://langdale.com.au/2005/Message#"
xmlns:sawSDL="http://www.w3.org/ns/sawSDL" xmlns="http://langdale.com.au/2005/Message#"
xmlns:m="http://iec.ch/TC57/2011/CustomerAgreementConfig#"
targetNamespace="http://iec.ch/TC57/2011/CustomerAgreementConfig#" elementFormDefault="qualified"
attributeFormDefault="unqualified">
  <xs:annotation/>
  <xs:element name="CustomerAgreementConfig" type="m:CustomerAgreementConfig"/>
  <xs:complexType name="CustomerAgreementConfig">
    <xs:sequence>
      <xs:element name="CustomerAgreement" type="m:CustomerAgreement" minOccurs="0"
maxOccurs="unbounded"/>
    </xs:sequence>
  </xs:complexType>
  <xs:complexType name="ConfigurationEvent" sawSDL:modelReference="http://iec.ch/TC57/CIM-
generic#ConfigurationEvent">
    <xs:annotation>
      <xs:documentation>Used to report details on creation, change or deletion of an entity or its
configuration.</xs:documentation>
    </xs:annotation>
    <xs:sequence>
      <xs:element name="mRID" type="xs:string" minOccurs="0" maxOccurs="1"
sawSDL:modelReference="http://iec.ch/TC57/CIM-generic#IdentifiedObject.mRID">
        <xs:annotation>
          <xs:documentation>A Model Authority issues mRIDs. Given that each Model
Authority has a unique id and this id is part of the mRID, then the mRID is globally unique.</xs:documentation>
          <xs:documentation>Global uniqueness is easily achieved by using a UUID for
the mRID. It is strongly recommended to do this.</xs:documentation>
          <xs:documentation>For CIMXML data files the mRID is mapped to rdf:ID or
rdf:about attributes that identifies CIM object elements.</xs:documentation>
        </xs:annotation>
      </xs:element>
      <xs:element name="createdDateTime" type="xs:dateTime" minOccurs="0" maxOccurs="1"
sawSDL:modelReference="http://iec.ch/TC57/CIM-generic#ActivityRecord.createdDateTime">
        <xs:annotation>
          <xs:documentation>Date and time this activity record has been created
(different from the 'status.dateTime', which is the time of a status change of the associated object, if
applicable).</xs:documentation>
        </xs:annotation>
      </xs:element>
      <xs:element name="effectiveDateTime" type="xs:dateTime" minOccurs="0" maxOccurs="1"
sawSDL:modelReference="http://iec.ch/TC57/CIM-generic#ConfigurationEvent.effectiveDateTime">
        <xs:annotation>
          <xs:documentation>Date and time this event has or will become
effective.</xs:documentation>
        </xs:annotation>
      </xs:element>
      <xs:element name="modifiedBy" type="xs:string" minOccurs="0" maxOccurs="1"
sawSDL:modelReference="http://iec.ch/TC57/CIM-generic#ConfigurationEvent.modifiedBy">
        <xs:annotation>
          <xs:documentation>Source/initiator of modification.</xs:documentation>
        </xs:annotation>
      </xs:element>
      <xs:element name="reason" type="xs:string" minOccurs="0" maxOccurs="1"
sawSDL:modelReference="http://iec.ch/TC57/CIM-generic#ActivityRecord.reason">
        <xs:annotation>
          <xs:documentation>Reason for event resulting in this activity record, typically
supplied when user initiated.</xs:documentation>
        </xs:annotation>
      </xs:element>
      <xs:element name="remark" type="xs:string" minOccurs="0" maxOccurs="1"
sawSDL:modelReference="http://iec.ch/TC57/CIM-generic#ConfigurationEvent.remark">
        <xs:annotation>
          <xs:documentation>Free text remarks.</xs:documentation>
        </xs:annotation>
      </xs:element>
      <xs:element name="severity" type="xs:string" minOccurs="0" maxOccurs="1"
sawSDL:modelReference="http://iec.ch/TC57/CIM-generic#ActivityRecord.severity">
        <xs:annotation>
          <xs:documentation>Severity level of event resulting in this activity
record.</xs:documentation>
        </xs:annotation>
      </xs:element>
      <xs:element name="type" type="xs:string" minOccurs="0" maxOccurs="1"
sawSDL:modelReference="http://iec.ch/TC57/CIM-generic#ActivityRecord.type">
        <xs:annotation>
          <xs:documentation>Type of event resulting in this activity

```

```

record.</xs:documentation>
    </xs:annotation>
    </xs:element>
    <xs:element name="Names" type="m:Name" minOccurs="0" maxOccurs="unbounded"
sawSDL:modelReference="http://iec.ch/TC57/CIM-generic#IdentifiedObject.Names">
    <xs:annotation>
    <xs:documentation>All names of this identified object.</xs:documentation>
    </xs:annotation>
    </xs:element>
    <xs:element name="status" type="m:Status" minOccurs="0" maxOccurs="1"
sawSDL:modelReference="http://iec.ch/TC57/CIM-generic#ActivityRecord.status">
    <xs:annotation>
    <xs:documentation>Information on consequence of event resulting in this
activity record.</xs:documentation>
    </xs:annotation>
    </xs:element>
</xs:sequence>
</xs:complexType>
<xs:complexType name="Customer" sawSDL:modelReference="http://iec.ch/TC57/CIM-generic#Customer">
    <xs:annotation>
    <xs:documentation>Organisation receiving services from service supplier.</xs:documentation>
    </xs:annotation>
    <xs:sequence>
    <xs:element name="mRID" type="xs:string" minOccurs="0" maxOccurs="1"
sawSDL:modelReference="http://iec.ch/TC57/CIM-generic#IdentifiedObject.mRID">
    <xs:annotation>
    <xs:documentation>A Model Authority issues mRIDs. Given that each Model
Authority has a unique id and this id is part of the mRID, then the mRID is globally unique.</xs:documentation>
    <xs:documentation>Global uniqueness is easily achieved by using a UUID for
the mRID. It is strongly recommended to do this.</xs:documentation>
    <xs:documentation>For CIMXML data files the mRID is mapped to rdf:ID or
rdf:about attributes that identifies CIM object elements.</xs:documentation>
    </xs:annotation>
    </xs:element>
    <xs:element name="Names" type="m:Name" minOccurs="0" maxOccurs="unbounded"
sawSDL:modelReference="http://iec.ch/TC57/CIM-generic#IdentifiedObject.Names">
    <xs:annotation>
    <xs:documentation>All names of this identified object.</xs:documentation>
    </xs:annotation>
    </xs:element>
    </xs:sequence>
</xs:complexType>
<xs:complexType name="CustomerAccount" sawSDL:modelReference="http://iec.ch/TC57/CIM-
generic#CustomerAccount">
    <xs:annotation>
    <xs:documentation>Assignment of a group of products and services purchased by the customer
through a customer agreement, used as a mechanism for customer billing and payment. It contains common information from
the various types of customer agreements to create billings (invoices) for a customer and receive payment.</xs:documentation>
    </xs:annotation>
    <xs:sequence>
    <xs:element name="mRID" type="xs:string" minOccurs="0" maxOccurs="1"
sawSDL:modelReference="http://iec.ch/TC57/CIM-generic#IdentifiedObject.mRID">
    <xs:annotation>
    <xs:documentation>A Model Authority issues mRIDs. Given that each Model
Authority has a unique id and this id is part of the mRID, then the mRID is globally unique.</xs:documentation>
    <xs:documentation>Global uniqueness is easily achieved by using a UUID for
the mRID. It is strongly recommended to do this.</xs:documentation>
    <xs:documentation>For CIMXML data files the mRID is mapped to rdf:ID or
rdf:about attributes that identifies CIM object elements.</xs:documentation>
    </xs:annotation>
    </xs:element>
    <xs:element name="Names" type="m:Name" minOccurs="0" maxOccurs="unbounded"
sawSDL:modelReference="http://iec.ch/TC57/CIM-generic#IdentifiedObject.Names">
    <xs:annotation>
    <xs:documentation>All names of this identified object.</xs:documentation>
    </xs:annotation>
    </xs:element>
    </xs:sequence>
</xs:complexType>
<xs:complexType name="CustomerAgreement" sawSDL:modelReference="http://iec.ch/TC57/CIM-
generic#CustomerAgreement">
    <xs:annotation>
    <xs:documentation>Agreement between the customer and the service supplier to pay for service
at a specific service location. It records certain billing information about the type of service provided at the service location and is
used during charge creation to determine the type of service.</xs:documentation>
    </xs:annotation>
    <xs:sequence>

```

```

<xs:element name="mRID" type="xs:string" minOccurs="0" maxOccurs="1"
sawSDL:modelReference="http://iec.ch/TC57/CIM-generic#IdentifiedObject.mRID">
  <xs:annotation>
    <xs:documentation>A Model Authority issues mRIDs. Given that each Model
Authority has a unique id and this id is part of the mRID, then the mRID is globally unique.</xs:documentation>
    <xs:documentation>Global uniqueness is easily achieved by using a UUID for
the mRID. It is strongly recommended to do this.</xs:documentation>
    <xs:documentation>For CIMXML data files the mRID is mapped to rdf:ID or
rdf:about attributes that identifies CIM object elements.</xs:documentation>
  </xs:annotation>
</xs:element>
<xs:element name="createdDateTime" type="xs:dateTime" minOccurs="0" maxOccurs="1"
sawSDL:modelReference="http://iec.ch/TC57/CIM-generic#Document.createdDateTime">
  <xs:annotation>
    <xs:documentation>Date and time that this document was
created.</xs:documentation>
  </xs:annotation>
</xs:element>
<xs:element name="lastModifiedDateTime" type="xs:dateTime" minOccurs="0" maxOccurs="1"
sawSDL:modelReference="http://iec.ch/TC57/CIM-generic#Document.lastModifiedDateTime">
  <xs:annotation>
    <xs:documentation>Date and time this document was last modified.
Documents may potentially be modified many times during their lifetime.</xs:documentation>
  </xs:annotation>
</xs:element>
<xs:element name="loadMgmt" type="xs:string" minOccurs="0" maxOccurs="1"
sawSDL:modelReference="http://iec.ch/TC57/CIM-generic#CustomerAgreement.loadMgmt">
  <xs:annotation>
    <xs:documentation>Load management code.</xs:documentation>
  </xs:annotation>
</xs:element>
<xs:element name="revisionNumber" type="xs:string" minOccurs="0" maxOccurs="1"
sawSDL:modelReference="http://iec.ch/TC57/CIM-generic#Document.revisionNumber">
  <xs:annotation>
    <xs:documentation>Revision number for this document.</xs:documentation>
  </xs:annotation>
</xs:element>
<xs:element name="signDate" type="xs:date" minOccurs="0" maxOccurs="1"
sawSDL:modelReference="http://iec.ch/TC57/CIM-generic#Agreement.signDate">
  <xs:annotation>
    <xs:documentation>Date this agreement was consummated among
associated persons and/or organisations.</xs:documentation>
  </xs:annotation>
</xs:element>
<xs:element name="subject" type="xs:string" minOccurs="0" maxOccurs="1"
sawSDL:modelReference="http://iec.ch/TC57/CIM-generic#Document.subject">
  <xs:annotation>
    <xs:documentation>Document subject.</xs:documentation>
  </xs:annotation>
</xs:element>
<xs:element name="title" type="xs:string" minOccurs="0" maxOccurs="1"
sawSDL:modelReference="http://iec.ch/TC57/CIM-generic#Document.title">
  <xs:annotation>
    <xs:documentation>Document title.</xs:documentation>
  </xs:annotation>
</xs:element>
<xs:element name="type" type="xs:string" minOccurs="0" maxOccurs="1"
sawSDL:modelReference="http://iec.ch/TC57/CIM-generic#Document.type">
  <xs:annotation>
    <xs:documentation>Utility-specific classification of this document, according
to their corporate standards, practices, and existing IT systems (e.g., for management of assets, maintenance, work, outage,
customers, etc.).</xs:documentation>
  </xs:annotation>
</xs:element>
<xs:element name="ConfigurationEvents" type="m:ConfigurationEvent" minOccurs="0"
maxOccurs="1" sawSDL:modelReference="http://iec.ch/TC57/CIM-generic#Document.ConfigurationEvents">
  <xs:annotation>
    <xs:documentation>All configuration events created for this
document.</xs:documentation>
  </xs:annotation>
</xs:element>
<xs:element name="DemandResponsePrograms" type="m:DemandResponseProgram"
minOccurs="0" maxOccurs="unbounded" sawSDL:modelReference="http://iec.ch/TC57/CIM-
generic#CustomerAgreement.DemandResponsePrograms">
  <xs:annotation>
    <xs:documentation>All demand response programs the customer is enrolled
in through this customer agreement.</xs:documentation>
  </xs:annotation>

```

```

        </xs:annotation>
      </xs:element>
      <xs:element name="docStatus" type="m:Status" minOccurs="0" maxOccurs="1"
sawSDL:modelReference="http://iec.ch/TC57/CIM-generic#Document.docStatus">
        <xs:annotation>
          <xs:documentation>Status of this document. For status of subject matter this
document represents (e.g., Agreement, Work), use 'status' attribute.</xs:documentation>
          <xs:documentation>Example values for 'docStatus.status' are draft,
approved, cancelled, etc.</xs:documentation>
        </xs:annotation>
      </xs:element>
      <xs:element name="Names" type="m:Name" minOccurs="0" maxOccurs="unbounded"
sawSDL:modelReference="http://iec.ch/TC57/CIM-generic#IdentifiedObject.Names">
        <xs:annotation>
          <xs:documentation>All names of this identified object.</xs:documentation>
        </xs:annotation>
      </xs:element>
      <xs:element name="ServiceCategory" type="m:ServiceCategory" minOccurs="0" maxOccurs="1"
sawSDL:modelReference="http://iec.ch/TC57/CIM-generic#CustomerAgreement.ServiceCategory">
        <xs:annotation>
          <xs:documentation>Service category for this
agreement.</xs:documentation>
        </xs:annotation>
      </xs:element>
      <xs:element name="status" type="m:Status" minOccurs="0" maxOccurs="1"
sawSDL:modelReference="http://iec.ch/TC57/CIM-generic#Document.status">
        <xs:annotation>
          <xs:documentation>Status of subject matter (e.g., Agreement, Work) this
document represents. For status of the document itself, use 'docStatus' attribute.</xs:documentation>
        </xs:annotation>
      </xs:element>
      <xs:element name="validityInterval" type="m:DateTimeInterval" minOccurs="0" maxOccurs="1"
sawSDL:modelReference="http://iec.ch/TC57/CIM-generic#Agreement.validityInterval">
        <xs:annotation>
          <xs:documentation>Date and time interval this agreement is valid (from
going into effect to termination).</xs:documentation>
        </xs:annotation>
      </xs:element>
    </xs:sequence>
  </xs:complexType>
  <xs:complexType name="DateTimeInterval" sawSDL:modelReference="http://iec.ch/TC57/CIM-
generic#DateTimeInterval">
    <xs:annotation>
      <xs:documentation>Interval of date and time.</xs:documentation>
    </xs:annotation>
    <xs:sequence>
      <xs:element name="end" type="xs:dateTime" minOccurs="0" maxOccurs="1"
sawSDL:modelReference="http://iec.ch/TC57/CIM-generic#DateTimeInterval.end">
        <xs:annotation>
          <xs:documentation>End date and time of this interval.</xs:documentation>
        </xs:annotation>
      </xs:element>
      <xs:element name="start" type="xs:dateTime" minOccurs="0" maxOccurs="1"
sawSDL:modelReference="http://iec.ch/TC57/CIM-generic#DateTimeInterval.start">
        <xs:annotation>
          <xs:documentation>Start date and time of this interval.</xs:documentation>
        </xs:annotation>
      </xs:element>
    </xs:sequence>
  </xs:complexType>
  <xs:complexType name="DemandResponseProgram" sawSDL:modelReference="http://iec.ch/TC57/CIM-
generic#DemandResponseProgram">
    <xs:annotation>
      <xs:documentation>Demand response program.</xs:documentation>
    </xs:annotation>
    <xs:sequence>
      <xs:element name="mRID" type="xs:string" minOccurs="0" maxOccurs="1"
sawSDL:modelReference="http://iec.ch/TC57/CIM-generic#IdentifiedObject.mRID">
        <xs:annotation>
          <xs:documentation>A Model Authority issues mRIDs. Given that each Model
Authority has a unique id and this id is part of the mRID, then the mRID is globally unique.</xs:documentation>
          <xs:documentation>Global uniqueness is easily achieved by using a UUID for
the mRID. It is strongly recommended to do this.</xs:documentation>
          <xs:documentation>For CIMXML data files the mRID is mapped to rdf:ID or
rdf:about attributes that identifies CIM object elements.</xs:documentation>
        </xs:annotation>
      </xs:element>

```

```

        <xs:element name="Names" type="m:Name" minOccurs="0" maxOccurs="unbounded"
sawSDL:modelReference="http://iec.ch/TC57/CIM-generic#IdentifiedObject.Names">
            <xs:annotation>
                <xs:documentation>All names of this identified object.</xs:documentation>
            </xs:annotation>
        </xs:element>
    </xs:sequence>
</xs:complexType>
<xs:complexType name="Name" sawSDL:modelReference="http://iec.ch/TC57/CIM-generic#Name">
    <xs:annotation>
        <xs:documentation>The Name class provides the means to define any number of human
readable names for an object. A name is &lt;b>not</b> to be used for defining inter-object relationships. For inter-object
relationships instead use the object identification 'mRID'.</xs:documentation>
    </xs:annotation>
    <xs:sequence>
        <xs:element name="name" type="xs:string" minOccurs="1" maxOccurs="1"
sawSDL:modelReference="http://iec.ch/TC57/CIM-generic#Name.name">
            <xs:annotation>
                <xs:documentation>Any free text that name the object.</xs:documentation>
            </xs:annotation>
        </xs:element>
        <xs:element name="NameType" type="m:NameType" minOccurs="0" maxOccurs="1"
sawSDL:modelReference="http://iec.ch/TC57/CIM-generic#Name.NameType">
            <xs:annotation>
                <xs:documentation>Type of this name.</xs:documentation>
            </xs:annotation>
        </xs:element>
    </xs:sequence>
</xs:complexType>
<xs:complexType name="NameType" sawSDL:modelReference="http://iec.ch/TC57/CIM-generic#NameType">
    <xs:annotation>
        <xs:documentation>Type of name. Possible values for attribute 'name' are implementation
dependent but standard profiles may specify types. An enterprise may have multiple IT systems each having its own local name
for the same object, e.g. a planning system may have different names from an EMS. An object may also have different names
within the same IT system, e.g. localName and aliasName as defined in CIM version 14. Their definitions from CIM14
are</xs:documentation>
        <xs:documentation>The localName is a human readable name of the object. It is only used with
objects organized in a naming hierarchy. localName: A free text name local to a node in a naming hierarchy similar to a file
directory structure. A power system related naming hierarchy may be: Substation, VoltageLevel, Equipment etc. Children of the
same parent in such a hierarchy have names that typically are unique among them.</xs:documentation>
        <xs:documentation>aliasName: A free text alternate name typically used in tabular reports where
the column width is limited.</xs:documentation>
    </xs:annotation>
    <xs:sequence>
        <xs:element name="description" type="xs:string" minOccurs="0" maxOccurs="1"
sawSDL:modelReference="http://iec.ch/TC57/CIM-generic#NameType.description">
            <xs:annotation>
                <xs:documentation>Description of the name type.</xs:documentation>
            </xs:annotation>
        </xs:element>
        <xs:element name="name" type="xs:string" minOccurs="1" maxOccurs="1"
sawSDL:modelReference="http://iec.ch/TC57/CIM-generic#NameType.name">
            <xs:annotation>
                <xs:documentation>Name of the name type.</xs:documentation>
            </xs:annotation>
        </xs:element>
        <xs:element name="NameTypeAuthority" type="m:NameTypeAuthority" minOccurs="0"
maxOccurs="1" sawSDL:modelReference="http://iec.ch/TC57/CIM-generic#NameType.NameTypeAuthority">
            <xs:annotation>
                <xs:documentation>Authority responsible for managing names of this
type.</xs:documentation>
            </xs:annotation>
        </xs:element>
    </xs:sequence>
</xs:complexType>
<xs:complexType name="NameTypeAuthority" sawSDL:modelReference="http://iec.ch/TC57/CIM-
generic#NameTypeAuthority">
    <xs:annotation>
        <xs:documentation>Authority responsible for creation and management of names of a given type;
typically an organization or an enterprise system.</xs:documentation>
    </xs:annotation>
    <xs:sequence>
        <xs:element name="description" type="xs:string" minOccurs="0" maxOccurs="1"
sawSDL:modelReference="http://iec.ch/TC57/CIM-generic#NameTypeAuthority.description">
            <xs:annotation>
                <xs:documentation>Description of the name type
authority.</xs:documentation>
            </xs:annotation>
        </xs:element>
    </xs:sequence>

```



```

        </xs:annotation>
      </xs:element>
      <xs:element name="name" type="xs:string" minOccurs="1" maxOccurs="1"
sawSDL:modelReference="http://iec.ch/TC57/CIM-generic#NameTypeAuthority.name">
        <xs:annotation>
          <xs:documentation>Name of the name type authority.</xs:documentation>
        </xs:annotation>
      </xs:element>
    </xs:sequence>
  </xs:complexType>
  <xs:complexType name="ServiceCategory" sawSDL:modelReference="http://iec.ch/TC57/CIM-
generic#ServiceCategory">
    <xs:annotation>
      <xs:documentation>Category of service provided to the customer.</xs:documentation>
    </xs:annotation>
    <xs:sequence>
      <xs:element name="mRID" type="xs:string" minOccurs="0" maxOccurs="1"
sawSDL:modelReference="http://iec.ch/TC57/CIM-generic#IdentifiedObject.mRID">
        <xs:annotation>
          <xs:documentation>A Model Authority issues mRIDs. Given that each Model
Authority has a unique id and this id is part of the mRID, then the mRID is globally unique.</xs:documentation>
          <xs:documentation>Global uniqueness is easily achieved by using a UUID for
the mRID. It is strongly recommended to do this.</xs:documentation>
          <xs:documentation>For CIMXML data files the mRID is mapped to rdf:ID or
rdf:about attributes that identifies CIM object elements.</xs:documentation>
        </xs:annotation>
      </xs:element>
      <xs:element name="kind" type="m:ServiceKind" minOccurs="0" maxOccurs="1"
sawSDL:modelReference="http://iec.ch/TC57/CIM-generic#ServiceCategory.kind">
        <xs:annotation>
          <xs:documentation>Kind of service.</xs:documentation>
        </xs:annotation>
      </xs:element>
      <xs:element name="Names" type="m:Name" minOccurs="0" maxOccurs="unbounded"
sawSDL:modelReference="http://iec.ch/TC57/CIM-generic#IdentifiedObject.Names">
        <xs:annotation>
          <xs:documentation>All names of this identified object.</xs:documentation>
        </xs:annotation>
      </xs:element>
    </xs:sequence>
  </xs:complexType>
  <xs:simpleType name="ServiceKind" sawSDL:modelReference="http://iec.ch/TC57/CIM-generic#ServiceKind">
    <xs:annotation>
      <xs:documentation>Kind of service.</xs:documentation>
    </xs:annotation>
    <xs:restriction base="xs:string">
      <xs:enumeration value="electricity">
        <xs:annotation>
          <xs:documentation>Electricity service.</xs:documentation>
        </xs:annotation>
      </xs:enumeration>
      <xs:enumeration value="gas">
        <xs:annotation>
          <xs:documentation>Gas service.</xs:documentation>
        </xs:annotation>
      </xs:enumeration>
      <xs:enumeration value="heat">
        <xs:annotation>
          <xs:documentation>Heat service.</xs:documentation>
        </xs:annotation>
      </xs:enumeration>
      <xs:enumeration value="internet">
        <xs:annotation>
          <xs:documentation>Internet service.</xs:documentation>
        </xs:annotation>
      </xs:enumeration>
      <xs:enumeration value="other">
        <xs:annotation>
          <xs:documentation>Other kind of service.</xs:documentation>
        </xs:annotation>
      </xs:enumeration>
      <xs:enumeration value="rates">
        <xs:annotation>
          <xs:documentation>Rates (e.g. tax, charge, toll, duty, tariff, etc.)
service.</xs:documentation>
        </xs:annotation>
      </xs:enumeration>
    </xs:restriction>
  </xs:simpleType>

```

```

        <xs:enumeration value="refuse">
          <xs:annotation>
            <xs:documentation>Refuse (waster) service.</xs:documentation>
          </xs:annotation>
        </xs:enumeration>
        <xs:enumeration value="sewerage">
          <xs:annotation>
            <xs:documentation>Sewerage service.</xs:documentation>
          </xs:annotation>
        </xs:enumeration>
        <xs:enumeration value="time">
          <xs:annotation>
            <xs:documentation>Time service.</xs:documentation>
          </xs:annotation>
        </xs:enumeration>
        <xs:enumeration value="tvLicence">
          <xs:annotation>
            <xs:documentation>TV license service.</xs:documentation>
          </xs:annotation>
        </xs:enumeration>
        <xs:enumeration value="water">
          <xs:annotation>
            <xs:documentation>Water service.</xs:documentation>
          </xs:annotation>
        </xs:enumeration>
      </xs:restriction>
    </xs:simpleType>
    <xs:complexType name="Status" sawsdl:modelReference="http://iec.ch/TC57/CIM-generic#Status">
      <xs:annotation>
        <xs:documentation>Current status information relevant to an entity.</xs:documentation>
      </xs:annotation>
      <xs:sequence>
        <xs:element name="dateTime" type="xs:dateTime" minOccurs="0" maxOccurs="1"
sawsdl:modelReference="http://iec.ch/TC57/CIM-generic#Status.dateTime">
          <xs:annotation>
            <xs:documentation>Date and time for which status 'value'
applies.</xs:documentation>
          </xs:annotation>
        </xs:element>
        <xs:element name="reason" type="xs:string" minOccurs="0" maxOccurs="1"
sawsdl:modelReference="http://iec.ch/TC57/CIM-generic#Status.reason">
          <xs:annotation>
            <xs:documentation>Reason code or explanation for why an object went to
the current status 'value'.</xs:documentation>
          </xs:annotation>
        </xs:element>
        <xs:element name="remark" type="xs:string" minOccurs="0" maxOccurs="1"
sawsdl:modelReference="http://iec.ch/TC57/CIM-generic#Status.remark">
          <xs:annotation>
            <xs:documentation>Pertinent information regarding the current 'value', as
free form text.</xs:documentation>
          </xs:annotation>
        </xs:element>
        <xs:element name="value" type="xs:string" minOccurs="0" maxOccurs="1"
sawsdl:modelReference="http://iec.ch/TC57/CIM-generic#Status.value">
          <xs:annotation>
            <xs:documentation>Status value at 'dateTime'; prior status changes may
have been kept in instances of activity records associated with the object to which this status applies.</xs:documentation>
          </xs:annotation>
        </xs:element>
      </xs:sequence>
    </xs:complexType>
  </xs:schema>

```

Figure A.3 – Customer agreement XSD

```

<?xml version="1.0" encoding="UTF-8"?>
<xs:schema xmlns:xs="http://www.w3.org/2001/XMLSchema" xmlns:a="http://langdale.com.au/2005/Message#"
xmlns:sawsdl="http://www.w3.org/ns/sawsdl" xmlns="http://langdale.com.au/2005/Message#"
xmlns:m="http://iec.ch/TC57/2014/ServiceRequests#" targetNamespace="http://iec.ch/TC57/2014/ServiceRequests#"
elementFormDefault="qualified" attributeFormDefault="unqualified">
  <xs:annotation>
    <xs:documentation/>
  </xs:annotation>
  <xs:element name="ServiceRequests" type="m:ServiceRequests"/>
  <xs:complexType name="ServiceRequests">
    <xs:sequence>
      <xs:element name="ActivityRecord" type="m:ActivityRecord" minOccurs="0"
maxOccurs="unbounded"/>
      <xs:element name="Customer" type="m:Customer" minOccurs="0" maxOccurs="unbounded"/>
      <xs:element name="Meter" type="m:Meter" minOccurs="0" maxOccurs="unbounded"/>
      <xs:element name="WorkTask" type="m:WorkTask" minOccurs="0" maxOccurs="unbounded"/>
      <xs:element name="WorkTimeSchedule" type="m:WorkTimeSchedule" minOccurs="0"
maxOccurs="unbounded"/>
    </xs:sequence>
  </xs:complexType>
  <xs:complexType name="ActivityRecord" sawsdl:modelReference="http://iec.ch/TC57/CIM-generic#ActivityRecord">
    <xs:annotation>
      <xs:documentation>Records activity for an entity at a point in time; activity may be for an event
that has already occurred or for a planned activity.</xs:documentation>
    </xs:annotation>
    <xs:sequence>
      <xs:element name="createdDateTime" type="xs:dateTime" minOccurs="1" maxOccurs="1"
sawsdl:modelReference="http://iec.ch/TC57/CIM-generic#ActivityRecord.createdDateTime">
        <xs:annotation>
          <xs:documentation>Date and time this activity record has been created
(different from the 'status.dateTime', which is the time of a status change of the associated object, if
applicable).</xs:documentation>
        </xs:annotation>
      </xs:element>
      <xs:element name="reason" type="xs:string" minOccurs="0" maxOccurs="1"
sawsdl:modelReference="http://iec.ch/TC57/CIM-generic#ActivityRecord.reason">
        <xs:annotation>
          <xs:documentation>Reason for event resulting in this activity record, typically
supplied when user initiated.</xs:documentation>
        </xs:annotation>
      </xs:element>
      <xs:element name="severity" type="xs:string" minOccurs="0" maxOccurs="1"
sawsdl:modelReference="http://iec.ch/TC57/CIM-generic#ActivityRecord.severity">
        <xs:annotation>
          <xs:documentation>Severity level of event resulting in this activity
record.</xs:documentation>
        </xs:annotation>
      </xs:element>
      <xs:element name="type" type="xs:string" minOccurs="1" maxOccurs="1"
sawsdl:modelReference="http://iec.ch/TC57/CIM-generic#ActivityRecord.type">
        <xs:annotation>
          <xs:documentation>Type of event resulting in this activity
record.</xs:documentation>
        </xs:annotation>
      </xs:element>
    </xs:sequence>
  </xs:complexType>
  <xs:complexType name="Customer" sawsdl:modelReference="http://iec.ch/TC57/CIM-generic#Customer">
    <xs:annotation>
      <xs:documentation>Organisation receiving services from service supplier.</xs:documentation>
    </xs:annotation>
    <xs:sequence>
      <xs:element name="mRID" type="xs:string" minOccurs="0" maxOccurs="1"
sawsdl:modelReference="http://iec.ch/TC57/CIM-generic#IdentifiedObject.mRID">
        <xs:annotation>
          <xs:documentation>Master resource identifier issued by a model authority.
The mRID must semantically be a UUID as specified in RFC 4122. The mRID is globally unique.</xs:documentation>
          <xs:documentation>For CIMXML data files in RDF syntax, the mRID is
mapped to rdf:ID or rdf:about attributes that identify CIM object elements.</xs:documentation>
        </xs:annotation>
      </xs:element>
      <xs:element name="kind" minOccurs="1" maxOccurs="1"
sawsdl:modelReference="http://iec.ch/TC57/CIM-generic#Customer.kind">
        <xs:annotation>
          <xs:documentation>Kind of customer.</xs:documentation>
        </xs:annotation>
      </xs:element>
    </xs:sequence>
  </xs:complexType>
  <xs:simpleType sawsdl:modelReference="http://iec.ch/TC57/CIM-

```



```

generic#CustomerKind">
    <xs:restriction base="xs:string">
        <xs:enumeration value="commercialIndustrial">
            <xs:annotation>
                <xs:documentation>Commercial industrial
customer.</xs:documentation>
            </xs:annotation>
        </xs:enumeration>
        <xs:enumeration value="energyServiceScheduler">
            <xs:annotation>
                <xs:documentation>Customer as energy
service scheduler.</xs:documentation>
            </xs:annotation>
        </xs:enumeration>
        <xs:enumeration value="energyServiceSupplier">
            <xs:annotation>
                <xs:documentation>Customer as energy
service supplier.</xs:documentation>
            </xs:annotation>
        </xs:enumeration>
        <xs:enumeration value="internalUse">
            <xs:annotation>
                <xs:documentation>Internal use
customer.</xs:documentation>
            </xs:annotation>
        </xs:enumeration>
        <xs:enumeration value="other">
            <xs:annotation>
                <xs:documentation>Other kind of
customer.</xs:documentation>
            </xs:annotation>
        </xs:enumeration>
        <xs:enumeration value="pumpingLoad">
            <xs:annotation>
                <xs:documentation>Pumping load
customer.</xs:documentation>
            </xs:annotation>
        </xs:enumeration>
        <xs:enumeration value="residential">
            <xs:annotation>
                <xs:documentation>Residential
customer.</xs:documentation>
            </xs:annotation>
        </xs:enumeration>
        <xs:enumeration value="residentialAndCommercial">
            <xs:annotation>
                <xs:documentation>Residential and
commercial customer.</xs:documentation>
            </xs:annotation>
        </xs:enumeration>
        <xs:enumeration value="residentialAndStreetlight">
            <xs:annotation>
                <xs:documentation>Residential and streetlight
customer.</xs:documentation>
            </xs:annotation>
        </xs:enumeration>
        <xs:enumeration value="residentialFarmService">
            <xs:annotation>
                <xs:documentation>Residential farm service
customer.</xs:documentation>
            </xs:annotation>
        </xs:enumeration>
        <xs:enumeration value="residentialStreetlightOthers">
            <xs:annotation>
                <xs:documentation>Residential streetlight or
other related customer.</xs:documentation>
            </xs:annotation>
        </xs:enumeration>
        <xs:enumeration value="windMachine">
            <xs:annotation>
                <xs:documentation>Wind machine
customer.</xs:documentation>
            </xs:annotation>
        </xs:enumeration>
    </xs:restriction>
</xs:simpleType>
</xs:element>

```

```

<xs:element name="pucNumber" type="xs:string" minOccurs="1" maxOccurs="1"
sawSDL:modelReference="http://iec.ch/TC57/CIM-generic#Customer.pucNumber">
  <xs:annotation>
    <xs:documentation>(if applicable) Public utilities commission (PUC)
identification number.</xs:documentation>
  </xs:annotation>
</xs:element>
<xs:element name="specialNeed" type="xs:string" minOccurs="1" maxOccurs="1"
sawSDL:modelReference="http://iec.ch/TC57/CIM-generic#Customer.specialNeed">
  <xs:annotation>
    <xs:documentation>True if customer organisation has special service needs
such as life support, hospitals, etc.</xs:documentation>
  </xs:annotation>
</xs:element>
<xs:element name="vip" type="xs:boolean" minOccurs="0" maxOccurs="1"
sawSDL:modelReference="http://iec.ch/TC57/CIM-generic#Customer.vip">
  <xs:annotation>
    <xs:documentation>(use 'priority' instead) True if this is an important
customer. Importance is for matters different than those in 'specialNeed' attribute.</xs:documentation>
  </xs:annotation>
</xs:element>
<xs:element name="CustomerAgreements" minOccurs="0" maxOccurs="unbounded"
sawSDL:modelReference="http://iec.ch/TC57/CIM-generic#Customer.CustomerAgreements">
  <xs:annotation>
    <xs:documentation>All agreements of this customer.</xs:documentation>
  </xs:annotation>
  <xs:complexType sawSDL:modelReference="http://iec.ch/TC57/CIM-
generic#CustomerAgreement">
    <xs:sequence>
      <xs:element name="mRID" type="xs:string" minOccurs="0"
maxOccurs="1" sawSDL:modelReference="http://iec.ch/TC57/CIM-generic#IdentifiedObject.mRID">
        <xs:annotation>
          <xs:documentation>Master resource identifier
issued by a model authority. The mRID must semantically be a UUID as specified in RFC 4122. The mRID is globally
unique.</xs:documentation>
        </xs:annotation>
        <xs:documentation>For CIMXML data files in
RDF syntax, the mRID is mapped to rdf:ID or rdf:about attributes that identify CIM object elements.</xs:documentation>
      </xs:element>
      <xs:element name="Names" type="m:Name" minOccurs="0"
maxOccurs="unbounded" sawSDL:modelReference="http://iec.ch/TC57/CIM-generic#IdentifiedObject.Names">
        <xs:annotation>
          <xs:documentation>All names of this identified
object.</xs:documentation>
        </xs:annotation>
      </xs:element>
      <xs:element name="UsagePoints" minOccurs="0"
maxOccurs="unbounded" sawSDL:modelReference="http://iec.ch/TC57/CIM-generic#CustomerAgreement.UsagePoints">
        <xs:annotation>
          <xs:documentation>All service delivery points
regulated by this customer agreement.</xs:documentation>
        </xs:annotation>
      <xs:complexType
sawSDL:modelReference="http://iec.ch/TC57/CIM-generic#UsagePoint">
        <xs:sequence>
          <xs:element name="checkBilling"
type="xs:boolean" minOccurs="0" maxOccurs="1" sawSDL:modelReference="http://iec.ch/TC57/CIM-
generic#UsagePoint.checkBilling">
            <xs:annotation>
              <xs:documentation>True if as a result of an inspection or otherwise, there is a reason to suspect that a previous
billing may have been performed with erroneous data. Value should be reset once this potential discrepancy has been
resolved.</xs:documentation>
            </xs:annotation>
          </xs:element>
          <xs:element name="grounded"
type="xs:boolean" minOccurs="0" maxOccurs="1" sawSDL:modelReference="http://iec.ch/TC57/CIM-
generic#UsagePoint.grounded">
            <xs:annotation>
              <xs:documentation>True if grounded.</xs:documentation>
            </xs:annotation>
          </xs:element>
          <xs:element name="isVirtual"
type="xs:boolean" minOccurs="0" maxOccurs="1" sawSDL:modelReference="http://iec.ch/TC57/CIM-
generic#UsagePoint.isVirtual">
            <xs:annotation>

```

`<xs:documentation>`If true, this usage point is virtual, i.e., no physical location exists in the network where a meter could be located to collect the meter readings. For example, one may define a virtual usage point to serve as an aggregation of usage for all of a company's premises distributed widely across the distribution territory. Otherwise, the usage point is physical, i.e., there is a logical point in the network where a meter could be located to collect meter readings.`</xs:documentation>`

```

</xs:annotation>
</xs:element>
<xs:element name="phaseCode"
minOccurs="0" maxOccurs="1" sawsdl:modelReference="http://iec.ch/TC57/CIM-generic#UsagePoint.phaseCode">
</xs:annotation>

```

`<xs:documentation>`Phase code. Number of wires and specific nominal phases can be deduced from enumeration literal values. For example, ABCN is three-phase, four-wire, s12n (splitSecondary12N) is single-phase, three-wire, and s1n and s2n are single-phase, two-wire.`</xs:documentation>`

```

</xs:annotation>
<xs:simpleType
sawsdl:modelReference="http://iec.ch/TC57/CIM-generic#PhaseCode">
</xs:restriction
base="xs:string">

```

```
<xs:enumeration value="A">
```

```
<xs:annotation>
```

```
<xs:documentation>Phase A.</xs:documentation>
```

```
</xs:annotation>
```

```
</xs:enumeration>
```

```
<xs:enumeration value="AB">
```

```
<xs:annotation>
```

```
<xs:documentation>Phases A and B.</xs:documentation>
```

```
</xs:annotation>
```

```
</xs:enumeration>
```

```
<xs:enumeration value="ABC">
```

```
<xs:annotation>
```

```
<xs:documentation>Phases A, B, and C.</xs:documentation>
```

```
</xs:annotation>
```

```
</xs:enumeration>
```

```
<xs:enumeration value="ABCN">
```

```
<xs:annotation>
```

```
<xs:documentation>Phases A, B, C, and N.</xs:documentation>
```

```
</xs:annotation>
```

```
</xs:enumeration>
```

```
<xs:enumeration value="ABN">
```

```
<xs:annotation>
```

```
<xs:documentation>Phases A, B, and neutral.</xs:documentation>
```

```
</xs:annotation>
```

```
</xs:enumeration>
```

```
<xs:enumeration value="AC">
```

```
<xs:annotation>
```

```
<xs:documentation>Phases A and C.</xs:documentation>
```

```
</xs:annotation>
```

```
</xs:enumeration>
<xs:enumeration value="ACN">
  <xs:annotation>
    <xs:documentation>Phases A, C and neutral.</xs:documentation>
  </xs:annotation>
</xs:enumeration>
<xs:enumeration value="AN">
  <xs:annotation>
    <xs:documentation>Phases A and neutral.</xs:documentation>
  </xs:annotation>
</xs:enumeration>
<xs:enumeration value="B">
  <xs:annotation>
    <xs:documentation>Phase B.</xs:documentation>
  </xs:annotation>
</xs:enumeration>
<xs:enumeration value="BC">
  <xs:annotation>
    <xs:documentation>Phases B and C.</xs:documentation>
  </xs:annotation>
</xs:enumeration>
<xs:enumeration value="BCN">
  <xs:annotation>
    <xs:documentation>Phases B, C, and neutral.</xs:documentation>
  </xs:annotation>
</xs:enumeration>
<xs:enumeration value="BN">
  <xs:annotation>
    <xs:documentation>Phases B and neutral.</xs:documentation>
  </xs:annotation>
</xs:enumeration>
<xs:enumeration value="C">
  <xs:annotation>
    <xs:documentation>Phase C.</xs:documentation>
  </xs:annotation>
</xs:enumeration>
<xs:enumeration value="CN">
  <xs:annotation>
```

```
<xs:documentation>Phases C and neutral.</xs:documentation>

</xs:annotation>
</xs:enumeration>
<xs:enumeration value="N">
<xs:annotation>
  <xs:documentation>Neutral phase.</xs:documentation>
</xs:annotation>
</xs:enumeration>
<xs:enumeration value="s1">
<xs:annotation>
  <xs:documentation>Secondary phase 1.</xs:documentation>
</xs:annotation>
</xs:enumeration>
<xs:enumeration value="s12">
<xs:annotation>
  <xs:documentation>Secondary phase 1 and 2.</xs:documentation>
</xs:annotation>
</xs:enumeration>
<xs:enumeration value="s12N">
<xs:annotation>
  <xs:documentation>Secondary phases 1, 2, and neutral.</xs:documentation>
</xs:annotation>
</xs:enumeration>
<xs:enumeration value="s1N">
<xs:annotation>
  <xs:documentation>Secondary phase 1 and neutral.</xs:documentation>
</xs:annotation>
</xs:enumeration>
<xs:enumeration value="s2">
<xs:annotation>
  <xs:documentation>Secondary phase 2.</xs:documentation>
</xs:annotation>
</xs:enumeration>
<xs:enumeration value="s2N">
<xs:annotation>
  <xs:documentation>Secondary phase 2 and neutral.</xs:documentation>
</xs:annotation>
</xs:enumeration>
</xs:restriction>
</xs:simpleType>
```

```

</xs:element>
<xs:element
  name="serviceDeliveryRemark" type="xs:string" minOccurs="0" maxOccurs="1"
  sawsdl:modelReference="http://iec.ch/TC57/CIM-generic#UsagePoint.serviceDeliveryRemark">
  <xs:annotation>
    <xs:documentation>Remarks about this usage point, for example the reason for it being rated with a non-nominal
    priority.</xs:documentation>
  </xs:annotation>
</xs:element>
<xs:element name="servicePriority"
  type="xs:string" minOccurs="0" maxOccurs="1" sawsdl:modelReference="http://iec.ch/TC57/CIM-
  generic#UsagePoint.servicePriority">
  <xs:annotation>
    <xs:documentation>Priority of service for this usage point. Note that usage points at the same service location can
    have different priorities.</xs:documentation>
  </xs:annotation>
</xs:element>
<xs:element
  name="ServiceLocation" type="m:ServiceLocation" minOccurs="0" maxOccurs="1"
  sawsdl:modelReference="http://iec.ch/TC57/CIM-generic#UsagePoint.ServiceLocation">
  <xs:annotation>
    <xs:documentation>Service location where the service delivered by this usage point is
    consumed.</xs:documentation>
  </xs:annotation>
</xs:element>
<xs:element
  name="ServiceMultipliers" minOccurs="0" maxOccurs="unbounded" sawsdl:modelReference="http://iec.ch/TC57/CIM-
  generic#UsagePoint.ServiceMultipliers">
  <xs:annotation>
    <xs:documentation>All multipliers applied at this usage point.</xs:documentation>
  </xs:annotation>
  <xs:complexType
    sawsdl:modelReference="http://iec.ch/TC57/CIM-generic#ServiceMultiplier">
    <xs:sequence>
      <xs:element name="mRID" type="xs:string" minOccurs="0" maxOccurs="1"
        sawsdl:modelReference="http://iec.ch/TC57/CIM-generic#IdentifiedObject.mRID">
        <xs:annotation>
          <xs:documentation>Master resource identifier issued by a model authority. The mRID must semantically be
          a UUID as specified in RFC 4122. The mRID is globally unique.</xs:documentation>
          <xs:documentation>For CIMXML data files in RDF syntax, the mRID is mapped to rdf:ID or rdf:about
          attributes that identify CIM object elements.</xs:documentation>
        </xs:annotation>
      </xs:element>
      <xs:element name="kind" minOccurs="0" maxOccurs="1" sawsdl:modelReference="http://iec.ch/TC57/CIM-
        generic#ServiceMultiplier.kind">
        <xs:annotation>
          <xs:documentation>Kind of multiplier.</xs:documentation>
        </xs:annotation>
        <xs:simpleType sawsdl:modelReference="http://iec.ch/TC57/CIM-generic#ServiceMultiplierKind">
          <xs:restriction base="xs:string">
            <xs:enumeration value="ctRatio">
              <xs:annotation>
                <xs:documentation>Current transformer ratio used to convert associated
                quantities to real measurements.</xs:documentation>
              </xs:annotation>
            </xs:enumeration>
          </xs:restriction>
        </xs:simpleType>
      </xs:element>
    </xs:sequence>
  </xs:complexType>
</xs:element>

```

```

        <xs:enumeration value="ptRatio">
            <xs:annotation>
                <xs:documentation>Voltage transformer ratio used to convert associated
quantities to real measurements.</xs:documentation>
            </xs:annotation>
        </xs:enumeration>
        <xs:enumeration value="transformerRatio">
            <xs:annotation>
                <xs:documentation>Product of the CT ratio and PT
ratio.</xs:documentation>
            </xs:annotation>
        </xs:enumeration>
    </xs:restriction>
</xs:simpleType>
</xs:element>
<xs:element name="value" type="xs:float" minOccurs="0" maxOccurs="1"
sawSDL:modelReference="http://iec.ch/TC57/CIM-generic#ServiceMultiplier.value">
    <xs:annotation>
        <xs:documentation>Multiplier value.</xs:documentation>
    </xs:annotation>
</xs:element>
<xs:element name="Names" type="m:Name" minOccurs="1" maxOccurs="unbounded"
sawSDL:modelReference="http://iec.ch/TC57/CIM-generic#IdentifiedObject.Names">
    <xs:annotation>
        <xs:documentation>All names of this identified object.</xs:documentation>
    </xs:annotation>
</xs:element>
</xs:sequence>
</xs:complexType>
</xs:element>
</xs:sequence>
</xs:complexType>
</xs:element>
</xs:sequence>
</xs:complexType>
</xs:element>
<xs:element name="Names" type="m:Name" minOccurs="0" maxOccurs="unbounded"
sawSDL:modelReference="http://iec.ch/TC57/CIM-generic#IdentifiedObject.Names">
    <xs:annotation>
        <xs:documentation>All names of this identified object.</xs:documentation>
    </xs:annotation>
</xs:element>
<xs:element name="status" minOccurs="0" maxOccurs="1"
sawSDL:modelReference="http://iec.ch/TC57/CIM-generic#Customer.status">
    <xs:annotation>
        <xs:documentation>Status of this customer.</xs:documentation>
    </xs:annotation>
    <xs:complexType sawSDL:modelReference="http://iec.ch/TC57/CIM-generic#Status">
        <xs:sequence>
            <xs:element name="dateTime" type="xs:dateTime" minOccurs="0"
maxOccurs="1" sawSDL:modelReference="http://iec.ch/TC57/CIM-generic#Status.dateTime">
                <xs:annotation>
                    <xs:documentation>Date and time for which
status 'value' applies.</xs:documentation>
                </xs:annotation>
            </xs:element>
        </xs:sequence>
    </xs:complexType>

```

```

</xs:annotation>
</xs:element>
<xs:element name="reason" type="xs:string" minOccurs="0"
maxOccurs="1" sawsdl:modelReference="http://iec.ch/TC57/CIM-generic#Status.reason">
  <xs:annotation>
    <xs:documentation>Reason code or
explanation for why an object went to the current status 'value'.</xs:documentation>
  </xs:annotation>
</xs:element>
<xs:element name="remark" type="xs:string" minOccurs="0"
maxOccurs="1" sawsdl:modelReference="http://iec.ch/TC57/CIM-generic#Status.remark">
  <xs:annotation>
    <xs:documentation>Pertinent information
regarding the current 'value', as free form text.</xs:documentation>
  </xs:annotation>
</xs:element>
<xs:element name="value" type="xs:string" minOccurs="1"
maxOccurs="1" sawsdl:modelReference="http://iec.ch/TC57/CIM-generic#Status.value">
  <xs:annotation>
    <xs:documentation>Status value at
'dateTime'; prior status changes may have been kept in instances of activity records associated with the object to which this
status applies.</xs:documentation>
  </xs:annotation>
</xs:element>
</xs:sequence>
</xs:complexType>
</xs:element>
</xs:sequence>
</xs:complexType>
<xs:complexType name="IntervalReading" sawsdl:modelReference="http://iec.ch/TC57/CIM-
generic#IntervalReading">
  <xs:annotation>
    <xs:documentation>Data captured at regular intervals of time. Interval data could be captured as
incremental data, absolute data, or relative data. The source for the data is usually a tariff quantity or an engineering quantity.
Data is typically captured in time-tagged, uniform, fixed-length intervals of 5 min, 10 min, 15 min, 30 min, or 60
min.</xs:documentation>
    <xs:documentation>Note: Interval Data is sometimes also called "Interval Data Readings"
(IDR).</xs:documentation>
  </xs:annotation>
  <xs:sequence>
    <xs:element name="reportedDateTime" type="xs:dateTime" minOccurs="0" maxOccurs="1"
sawsdl:modelReference="http://iec.ch/TC57/CIM-generic#BaseReading.reportedDateTime">
      <xs:annotation>
        <xs:documentation>(used only when there are detailed auditing
requirements) Date and time at which the reading was first delivered to the metering system.</xs:documentation>
      </xs:annotation>
    </xs:element>
    <xs:element name="source" type="xs:string" minOccurs="0" maxOccurs="1"
sawsdl:modelReference="http://iec.ch/TC57/CIM-generic#BaseReading.source">
      <xs:annotation>
        <xs:documentation>System that originally supplied the reading (e.g.,
customer, AMI system, handheld reading system, another enterprise system, etc.).</xs:documentation>
      </xs:annotation>
    </xs:element>
    <xs:element name="timeStamp" type="xs:dateTime" minOccurs="1" maxOccurs="1"
sawsdl:modelReference="http://iec.ch/TC57/CIM-generic#MeasurementValue.timeStamp">
      <xs:annotation>
        <xs:documentation>The time when the value was last
updated</xs:documentation>
      </xs:annotation>
    </xs:element>
    <xs:element name="value" type="xs:string" minOccurs="1" maxOccurs="1"
sawsdl:modelReference="http://iec.ch/TC57/CIM-generic#BaseReading.value">
      <xs:annotation>
        <xs:documentation>Value of this reading.</xs:documentation>
      </xs:annotation>
    </xs:element>
    <xs:element name="ReadingQualities" minOccurs="0" maxOccurs="unbounded"
sawsdl:modelReference="http://iec.ch/TC57/CIM-generic#BaseReading.ReadingQualities">
      <xs:annotation>
        <xs:documentation>All qualities of this reading.</xs:documentation>
      </xs:annotation>
      <xs:complexType sawsdl:modelReference="http://iec.ch/TC57/CIM-
generic#ReadingQuality">
        <xs:sequence>
          <xs:element name="comment" type="xs:string" minOccurs="0"
maxOccurs="1" sawsdl:modelReference="http://iec.ch/TC57/CIM-generic#ReadingQuality.comment">

```



```

</xs:documentation>
</xs:documentation>Elaboration on the quality
code.</xs:documentation>
</xs:annotation>
</xs:element>
<xs:element name="source" type="xs:string" minOccurs="0"
maxOccurs="1" sawsdl:modelReference="http://iec.ch/TC57/CIM-generic#ReadingQuality.source">
</xs:annotation>
</xs:documentation>System acting as the
source of the quality code.</xs:documentation>
</xs:annotation>
</xs:element>
<xs:element name="timeStamp" type="xs:dateTime"
minOccurs="0" maxOccurs="1" sawsdl:modelReference="http://iec.ch/TC57/CIM-generic#ReadingQuality.timeStamp">
</xs:annotation>
</xs:documentation>Date and time at which
the quality code was assigned or ascertained.</xs:documentation>
</xs:annotation>
</xs:element>
</xs:sequence>
</xs:complexType>
</xs:element>
<xs:element name="timePeriod" minOccurs="0" maxOccurs="1"
sawsdl:modelReference="http://iec.ch/TC57/CIM-generic#BaseReading.timePeriod">
</xs:annotation>
</xs:documentation>Start and end of the period for those readings whose
type has a time attribute such as 'billing', seasonal' or 'forTheSpecifiedPeriod'.</xs:documentation>
</xs:annotation>
<xs:complexType sawsdl:modelReference="http://iec.ch/TC57/CIM-
generic#DateTimeInterval">
</xs:sequence>
<xs:element name="end" type="xs:dateTime" minOccurs="1"
maxOccurs="1" sawsdl:modelReference="http://iec.ch/TC57/CIM-generic#DateTimeInterval.end">
</xs:annotation>
</xs:documentation>End date and time of this
interval.</xs:documentation>
</xs:annotation>
</xs:element>
<xs:element name="start" type="xs:dateTime" minOccurs="1"
maxOccurs="1" sawsdl:modelReference="http://iec.ch/TC57/CIM-generic#DateTimeInterval.start">
</xs:annotation>
</xs:documentation>Start date and time of this
interval.</xs:documentation>
</xs:annotation>
</xs:element>
</xs:sequence>
</xs:complexType>
</xs:element>
</xs:sequence>
</xs:complexType>
<xs:complexType name="Meter" sawsdl:modelReference="http://iec.ch/TC57/CIM-generic#Meter">
</xs:annotation>
</xs:documentation>Physical asset that performs the metering role of the usage point. Used for
measuring consumption and detection of events.</xs:documentation>
</xs:annotation>
</xs:sequence>
<xs:element name="mRID" type="xs:string" minOccurs="0" maxOccurs="1"
sawsdl:modelReference="http://iec.ch/TC57/CIM-generic#IdentifiedObject.mRID">
</xs:annotation>
</xs:documentation>Master resource identifier issued by a model authority.
The mRID must semantically be a UUID as specified in RFC 4122. The mRID is globally unique.</xs:documentation>
</xs:documentation>For CIMXML data files in RDF syntax, the mRID is
mapped to rdf:ID or rdf:about attributes that identify CIM object elements.</xs:documentation>
</xs:annotation>
</xs:element>
<xs:element name="amrSystem" type="xs:string" minOccurs="0" maxOccurs="1"
sawsdl:modelReference="http://iec.ch/TC57/CIM-generic#EndDevice.amrSystem">
</xs:annotation>
</xs:documentation>Automated meter reading (AMR) or other communication
system responsible for communications to this end device.</xs:documentation>
</xs:annotation>
</xs:element>
<xs:element name="formNumber" type="xs:string" minOccurs="0" maxOccurs="1"
sawsdl:modelReference="http://iec.ch/TC57/CIM-generic#Meter.formNumber">
</xs:annotation>
</xs:documentation>Meter form designation per ANSI C12.10 or other
applicable standard. An alphanumeric designation denoting the circuit arrangement for which the meter is applicable and its

```

```

specific terminal arrangement.</xs:documentation>
    </xs:annotation>
  </xs:element>
  <xs:element name="serialNumber" type="xs:string" minOccurs="0" maxOccurs="1"
sawSDL:modelReference="http://iec.ch/TC57/CIM-generic#Asset.serialNumber">
    <xs:annotation>
      <xs:documentation>Serial number of this asset.</xs:documentation>
    </xs:annotation>
  </xs:element>
  <xs:element name="MeterMultipliers" type="m:MeterMultiplier" minOccurs="0"
maxOccurs="unbounded" sawSDL:modelReference="http://iec.ch/TC57/CIM-generic#Meter.MeterMultipliers">
    <xs:annotation>
      <xs:documentation>All multipliers applied at this meter.</xs:documentation>
    </xs:annotation>
  </xs:element>
  <xs:element name="MeterReadings" type="m:MeterReading" minOccurs="0"
maxOccurs="unbounded" sawSDL:modelReference="http://iec.ch/TC57/CIM-generic#Meter.MeterReadings">
    <xs:annotation>
      <xs:documentation>All meter readings provided by this
meter.</xs:documentation>
    </xs:annotation>
  </xs:element>
  <xs:element name="Names" minOccurs="0" maxOccurs="unbounded"
sawSDL:modelReference="http://iec.ch/TC57/CIM-generic#IdentifiedObject.Names">
    <xs:annotation>
      <xs:documentation>All names of this identified object.</xs:documentation>
    </xs:annotation>
    <xs:complexType sawSDL:modelReference="http://iec.ch/TC57/CIM-generic#Name">
      <xs:sequence>
        <xs:element name="name" type="xs:string" minOccurs="1"
maxOccurs="1" sawSDL:modelReference="http://iec.ch/TC57/CIM-generic#Name.name">
          <xs:annotation>
            <xs:documentation>Any free text that name
the object.</xs:documentation>
          </xs:annotation>
        </xs:element>
        <xs:element name="NameType" minOccurs="0" maxOccurs="1"
sawSDL:modelReference="http://iec.ch/TC57/CIM-generic#Name.NameType">
          <xs:annotation>
            <xs:documentation>Type of this
name.</xs:documentation>
          </xs:annotation>
          <xs:complexType
sawSDL:modelReference="http://iec.ch/TC57/CIM-generic#NameType">
            <xs:sequence>
              <xs:element name="description"
type="xs:string" minOccurs="0" maxOccurs="1" sawSDL:modelReference="http://iec.ch/TC57/CIM-
generic#NameType.description">
                <xs:annotation>
                  <xs:documentation>Description of the name type.</xs:documentation>
                </xs:annotation>
              </xs:element>
              <xs:element name="name"
type="xs:string" minOccurs="1" maxOccurs="1" sawSDL:modelReference="http://iec.ch/TC57/CIM-generic#NameType.name">
                <xs:annotation>
                  <xs:documentation>Name of the name type.</xs:documentation>
                </xs:annotation>
              </xs:element>
            </xs:sequence>
          </xs:complexType>
        </xs:sequence>
      </xs:complexType>
    </xs:sequence>
  </xs:complexType>
  <xs:complexType name="MeterMultiplier" sawSDL:modelReference="http://iec.ch/TC57/CIM-generic#MeterMultiplier">
    <xs:annotation>
      <xs:documentation>Multiplier applied at the meter.</xs:documentation>
    </xs:annotation>
    <xs:sequence>
      <xs:element name="mRID" type="xs:string" minOccurs="0" maxOccurs="1"
sawSDL:modelReference="http://iec.ch/TC57/CIM-generic#IdentifiedObject.mRID">
        <xs:annotation>
          <xs:documentation>Master resource identifier issued by a model authority.

```

```

The mRID must semantically be a UUID as specified in RFC 4122. The mRID is globally unique.</xs:documentation>
<xs:documentation>For CIMXML data files in RDF syntax, the mRID is
mapped to rdf:ID or rdf:about attributes that identify CIM object elements.</xs:documentation>
</xs:annotation>
</xs:element>
<xs:element name="kind" minOccurs="1" maxOccurs="1"
sawSDL:modelReference="http://iec.ch/TC57/CIM-generic#MeterMultiplier.kind">
<xs:annotation>
<xs:documentation>Kind of multiplier.</xs:documentation>
</xs:annotation>
<xs:simpleType sawSDL:modelReference="http://iec.ch/TC57/CIM-
generic#MeterMultiplierKind">
<xs:restriction base="xs:string">
<xs:enumeration value="ctRatio">
<xs:annotation>
<xs:documentation>Current transformer ratio
used to convert associated quantities to real measurements.</xs:documentation>
</xs:annotation>
</xs:enumeration>
<xs:enumeration value="kE">
<xs:annotation>
<xs:documentation>Test
constant.</xs:documentation>
</xs:annotation>
</xs:enumeration>
<xs:enumeration value="kH">
<xs:annotation>
<xs:documentation>Meter kh (watthour)
constant. The number of watthours that must be applied to the meter to cause one disk revolution for an electromechanical
meter or the number of watthours represented by one increment pulse for an electronic meter.</xs:documentation>
</xs:annotation>
</xs:enumeration>
<xs:enumeration value="kR">
<xs:annotation>
<xs:documentation>Register multiplier. The
number to multiply the register reading by in order to get kWh.</xs:documentation>
</xs:annotation>
</xs:enumeration>
<xs:enumeration value="ptRatio">
<xs:annotation>
<xs:documentation>Potential transformer ratio
used to convert associated quantities to real measurements.</xs:documentation>
</xs:annotation>
</xs:enumeration>
<xs:enumeration value="transformerRatio">
<xs:annotation>
<xs:documentation>Product of the CT ratio
and PT ratio.</xs:documentation>
</xs:annotation>
</xs:enumeration>
</xs:restriction>
</xs:simpleType>
</xs:element>
<xs:element name="value" type="xs:float" minOccurs="1" maxOccurs="1"
sawSDL:modelReference="http://iec.ch/TC57/CIM-generic#MeterMultiplier.value">
<xs:annotation>
<xs:documentation>Multiplier value.</xs:documentation>
</xs:annotation>
</xs:element>
<xs:element name="Names" type="m:Name" minOccurs="0" maxOccurs="unbounded"
sawSDL:modelReference="http://iec.ch/TC57/CIM-generic#IdentifiedObject.Names">
<xs:annotation>
<xs:documentation>All names of this identified object.</xs:documentation>
</xs:annotation>
</xs:element>
</xs:sequence>
</xs:complexType>
<xs:complexType name="MeterReading" sawSDL:modelReference="http://iec.ch/TC57/CIM-generic#MeterReading">
<xs:annotation>
<xs:documentation>Set of values obtained from the meter.</xs:documentation>
</xs:annotation>
<xs:sequence>
<xs:element name="Readings" type="m:Reading" minOccurs="0" maxOccurs="unbounded"
sawSDL:modelReference="http://iec.ch/TC57/CIM-generic#MeterReading.Readings">
<xs:annotation>
<xs:documentation>All reading values contained within this meter
reading.</xs:documentation>

```

```

        </xs:annotation>
      </xs:element>
      <xs:element name="valuesInterval" minOccurs="0" maxOccurs="1"
sawSDL:modelReference="http://iec.ch/TC57/CIM-generic#MeterReading.valuesInterval">
        <xs:annotation>
          <xs:documentation>Date and time interval of the data items contained within
this meter reading.</xs:documentation>
        </xs:annotation>
      </xs:complexType sawSDL:modelReference="http://iec.ch/TC57/CIM-
generic#DateTimeInterval">
        <xs:sequence>
          <xs:element name="end" type="xs:dateTime" minOccurs="1"
maxOccurs="1" sawSDL:modelReference="http://iec.ch/TC57/CIM-generic#DateTimeInterval.end">
            <xs:annotation>
              <xs:documentation>End date and time of this
interval.</xs:documentation>
            </xs:annotation>
          </xs:element>
          <xs:element name="start" type="xs:dateTime" minOccurs="1"
maxOccurs="1" sawSDL:modelReference="http://iec.ch/TC57/CIM-generic#DateTimeInterval.start">
            <xs:annotation>
              <xs:documentation>Start date and time of this
interval.</xs:documentation>
            </xs:annotation>
          </xs:element>
        </xs:sequence>
      </xs:complexType>
    </xs:element>
  </xs:sequence>
</xs:complexType>
<xs:complexType name="Name" sawSDL:modelReference="http://iec.ch/TC57/CIM-generic#Name">
  <xs:annotation>
    <xs:documentation>The Name class provides the means to define any number of human
readable names for an object. A name is &lt;b>&not;&b> to be used for defining inter-object relationships. For inter-object
relationships instead use the object identification 'mRID'.</xs:documentation>
  </xs:annotation>
  <xs:sequence>
    <xs:element name="name" type="xs:string" minOccurs="1" maxOccurs="1"
sawSDL:modelReference="http://iec.ch/TC57/CIM-generic#Name.name">
      <xs:annotation>
        <xs:documentation>Any free text that name the object.</xs:documentation>
      </xs:annotation>
    </xs:element>
    <xs:element name="NameType" minOccurs="0" maxOccurs="1"
sawSDL:modelReference="http://iec.ch/TC57/CIM-generic#Name.NameType">
      <xs:annotation>
        <xs:documentation>Type of this name.</xs:documentation>
      </xs:annotation>
    </xs:complexType sawSDL:modelReference="http://iec.ch/TC57/CIM-
generic#NameType">
      <xs:sequence>
        <xs:element name="description" type="xs:string" minOccurs="0"
maxOccurs="1" sawSDL:modelReference="http://iec.ch/TC57/CIM-generic#NameType.description">
          <xs:annotation>
            <xs:documentation>Description of the name
type.</xs:documentation>
          </xs:annotation>
        </xs:element>
        <xs:element name="name" type="xs:string" minOccurs="1"
maxOccurs="1" sawSDL:modelReference="http://iec.ch/TC57/CIM-generic#NameType.name">
          <xs:annotation>
            <xs:documentation>Name of the name
type.</xs:documentation>
          </xs:annotation>
        </xs:element>
      </xs:sequence>
    </xs:complexType>
  </xs:element>
</xs:sequence>
</xs:complexType>
<xs:complexType name="Reading" sawSDL:modelReference="http://iec.ch/TC57/CIM-generic#Reading">
  <xs:annotation>
    <xs:documentation>Specific value measured by a meter or other asset, or calculated by a
system. Each Reading is associated with a specific ReadingType.</xs:documentation>
  </xs:annotation>
  <xs:sequence>
    <xs:element name="reason" minOccurs="0" maxOccurs="1"

```

```

sawsdl:modelReference="http://iec.ch/TC57/CIM-generic#Reading.reason">
  <xs:annotation>
    <xs:documentation>Reason for this reading being
taken.</xs:documentation>
  </xs:annotation>
<xs:simpleType sawsdl:modelReference="http://iec.ch/TC57/CIM-
generic#ReadingReasonKind">
  <xs:restriction base="xs:string">
    <xs:enumeration value="billing">
      <xs:annotation>
        <xs:documentation>Reading(s) taken or to be
taken in response to a billing-related inquiry by a customer or other party. A variant of 'inquiry'.</xs:documentation>
      </xs:annotation>
    </xs:enumeration>
    <xs:enumeration value="demandReset">
      <xs:annotation>
        <xs:documentation>Reading(s) taken or to be
taken in conjunction with the resetting of one or more demand registers in a meter.</xs:documentation>
      </xs:annotation>
    </xs:enumeration>
    <xs:enumeration value="inquiry">
      <xs:annotation>
        <xs:documentation>Reading(s) taken or to be
taken in response to an inquiry by a customer or other party.</xs:documentation>
      </xs:annotation>
    </xs:enumeration>
    <xs:enumeration value="installation">
      <xs:annotation>
        <xs:documentation>Reading(s) taken or to be
taken in conjunction with installation of a meter.</xs:documentation>
      </xs:annotation>
    </xs:enumeration>
    <xs:enumeration value="loadManagement">
      <xs:annotation>
        <xs:documentation>Reading(s) taken or to be
taken to support management of loads on distribution networks or devices.</xs:documentation>
      </xs:annotation>
    </xs:enumeration>
    <xs:enumeration value="loadResearch">
      <xs:annotation>
        <xs:documentation>Reading(s) taken or to be
taken to support research and analysis of loads on distribution networks or devices.</xs:documentation>
      </xs:annotation>
    </xs:enumeration>
    <xs:enumeration value="moveIn">
      <xs:annotation>
        <xs:documentation>Reading(s) taken or to be
taken in conjunction with a customer move-in event.</xs:documentation>
      </xs:annotation>
    </xs:enumeration>
    <xs:enumeration value="moveOut">
      <xs:annotation>
        <xs:documentation>Reading(s) taken or to be
taken in conjunction with a customer move-out event.</xs:documentation>
      </xs:annotation>
    </xs:enumeration>
    <xs:enumeration value="other">
      <xs:annotation>
        <xs:documentation>Reading(s) taken or to be
taken for some other reason or purpose.</xs:documentation>
      </xs:annotation>
    </xs:enumeration>
    <xs:enumeration value="removal">
      <xs:annotation>
        <xs:documentation>Reading(s) taken or to be
taken in conjunction with removal of a meter.</xs:documentation>
      </xs:annotation>
    </xs:enumeration>
    <xs:enumeration value="serviceConnect">
      <xs:annotation>
        <xs:documentation>Reading(s) taken or to be
taken in conjunction with a connection or re-connection of service.</xs:documentation>
      </xs:annotation>
    </xs:enumeration>
    <xs:enumeration value="serviceDisconnect">
      <xs:annotation>
        <xs:documentation>Reading(s) taken or to be

```

```

taken in conjunction with a disconnection of service.</xs:documentation>
</xs:annotation>
</xs:enumeration>
</xs:restriction>
</xs:simpleType>
</xs:element>
<xs:element name="reportedDateTime" type="xs:dateTime" minOccurs="0" maxOccurs="1"
sawSDL:modelReference="http://iec.ch/TC57/CIM-generic#BaseReading.reportedDateTime">
<xs:annotation>
<xs:documentation>(used only when there are detailed auditing
requirements) Date and time at which the reading was first delivered to the metering system.</xs:documentation>
</xs:annotation>
</xs:element>
<xs:element name="source" type="xs:string" minOccurs="0" maxOccurs="1"
sawSDL:modelReference="http://iec.ch/TC57/CIM-generic#BaseReading.source">
<xs:annotation>
<xs:documentation>System that originally supplied the reading (e.g.,
customer, AMI system, handheld reading system, another enterprise system, etc.).</xs:documentation>
</xs:annotation>
</xs:element>
<xs:element name="timeStamp" type="xs:dateTime" minOccurs="1" maxOccurs="1"
sawSDL:modelReference="http://iec.ch/TC57/CIM-generic#MeasurementValue.timeStamp">
<xs:annotation>
<xs:documentation>The time when the value was last
updated</xs:documentation>
</xs:annotation>
</xs:element>
<xs:element name="value" type="xs:string" minOccurs="0" maxOccurs="1"
sawSDL:modelReference="http://iec.ch/TC57/CIM-generic#BaseReading.value">
<xs:annotation>
<xs:documentation>Value of this reading.</xs:documentation>
</xs:annotation>
</xs:element>
<xs:element name="ReadingQualities" minOccurs="0" maxOccurs="unbounded"
sawSDL:modelReference="http://iec.ch/TC57/CIM-generic#BaseReading.ReadingQualities">
<xs:annotation>
<xs:documentation>All qualities of this reading.</xs:documentation>
</xs:annotation>
<xs:complexType sawSDL:modelReference="http://iec.ch/TC57/CIM-
generic#ReadingQuality">
<xs:sequence>
<xs:element name="comment" type="xs:string" minOccurs="0"
maxOccurs="1" sawSDL:modelReference="http://iec.ch/TC57/CIM-generic#ReadingQuality.comment">
<xs:annotation>
<xs:documentation>Elaboration on the quality
code.</xs:documentation>
</xs:annotation>
</xs:element>
<xs:element name="source" type="xs:string" minOccurs="0"
maxOccurs="1" sawSDL:modelReference="http://iec.ch/TC57/CIM-generic#ReadingQuality.source">
<xs:annotation>
<xs:documentation>System acting as the
source of the quality code.</xs:documentation>
</xs:annotation>
</xs:element>
<xs:element name="timeStamp" type="xs:dateTime"
minOccurs="0" maxOccurs="1" sawSDL:modelReference="http://iec.ch/TC57/CIM-generic#ReadingQuality.timeStamp">
<xs:annotation>
<xs:documentation>Date and time at which
the quality code was assigned or ascertained.</xs:documentation>
</xs:annotation>
</xs:element>
<xs:element name="ReadingQualityType" minOccurs="1"
maxOccurs="1" sawSDL:modelReference="http://iec.ch/TC57/CIM-generic#ReadingQuality.ReadingQualityType">
<xs:annotation>
<xs:documentation>Type of this reading
quality.</xs:documentation>
</xs:annotation>
<xs:complexType sawSDL:modelReference="">
<xs:attribute name="ref" type="xs:string"/>
</xs:complexType>
</xs:element>
</xs:sequence>
</xs:complexType>
</xs:element>
<xs:element name="ReadingType" minOccurs="1" maxOccurs="1"
sawSDL:modelReference="http://iec.ch/TC57/CIM-generic#Reading.ReadingType">

```



```

        <xs:annotation>
            <xs:documentation>Type information for this reading
value.</xs:documentation>
        </xs:annotation>
        <xs:complexType sawsdl:modelReference="">
            <xs:attribute name="ref" type="xs:string"/>
        </xs:complexType>
    </xs:element>
    <xs:element name="timePeriod" minOccurs="0" maxOccurs="1"
sawsdl:modelReference="http://iec.ch/TC57/CIM-generic#BaseReading.timePeriod">
        <xs:annotation>
            <xs:documentation>Start and end of the period for those readings whose
type has a time attribute such as 'billing', seasonal' or 'forTheSpecifiedPeriod'.</xs:documentation>
        </xs:annotation>
        <xs:complexType sawsdl:modelReference="http://iec.ch/TC57/CIM-
generic#DateTimeInterval">
            <xs:sequence>
                <xs:element name="end" type="xs:dateTime" minOccurs="1"
maxOccurs="1" sawsdl:modelReference="http://iec.ch/TC57/CIM-generic#DateTimeInterval.end">
                    <xs:annotation>
                        <xs:documentation>End date and time of this
interval.</xs:documentation>
                    </xs:annotation>
                </xs:element>
                <xs:element name="start" type="xs:dateTime" minOccurs="1"
maxOccurs="1" sawsdl:modelReference="http://iec.ch/TC57/CIM-generic#DateTimeInterval.start">
                    <xs:annotation>
                        <xs:documentation>Start date and time of this
interval.</xs:documentation>
                    </xs:annotation>
                </xs:element>
            </xs:sequence>
        </xs:complexType>
    </xs:element>
    <xs:sequence>
        <xs:complexType name="ServiceLocation" sawsdl:modelReference="http://iec.ch/TC57/CIM-
generic#ServiceLocation">
            <xs:annotation>
                <xs:documentation>A real estate location, commonly referred to as
premises.</xs:documentation>
            </xs:annotation>
            <xs:sequence>
                <xs:element name="mRID" type="xs:string" minOccurs="0" maxOccurs="1"
sawsdl:modelReference="http://iec.ch/TC57/CIM-generic#IdentifiedObject.mRID">
                    <xs:annotation>
                        <xs:documentation>Master resource identifier issued by a model authority.
The mRID must semantically be a UUID as specified in RFC 4122. The mRID is globally unique.</xs:documentation>
                    </xs:annotation>
                    <xs:documentation>For CIMXML data files in RDF syntax, the mRID is
mapped to rdf:ID or rdf:about attributes that identify CIM object elements.</xs:documentation>
                    </xs:annotation>
                </xs:element>
                <xs:element name="accessMethod" type="xs:string" minOccurs="0" maxOccurs="1"
sawsdl:modelReference="http://iec.ch/TC57/CIM-generic#ServiceLocation.accessMethod">
                    <xs:annotation>
                        <xs:documentation>Method for the service person to access this service
location. For example, a description of where to obtain a key if the facility is unmanned and secured.</xs:documentation>
                    </xs:annotation>
                </xs:element>
                <xs:element name="direction" type="xs:string" minOccurs="0" maxOccurs="1"
sawsdl:modelReference="http://iec.ch/TC57/CIM-generic#Location.direction">
                    <xs:annotation>
                        <xs:documentation>(if applicable) Direction that allows field crews to quickly
find a given asset. For a given location, such as a street address, this is the relative direction in which to find the asset. For
example, a streetlight may be located at the 'NW' (northwest) corner of the customer's site, or a usage point may be located on
the second floor of an apartment building.</xs:documentation>
                    </xs:annotation>
                </xs:element>
                <xs:element name="needsInspection" type="xs:boolean" minOccurs="0" maxOccurs="1"
sawsdl:modelReference="http://iec.ch/TC57/CIM-generic#ServiceLocation.needsInspection">
                    <xs:annotation>
                        <xs:documentation>True if inspection is needed of facilities at this service
location. This could be requested by a customer, due to suspected tampering, environmental concerns (e.g., a fire in the
vicinity), or to correct incompatible data.</xs:documentation>
                    </xs:annotation>
                </xs:element>
                <xs:element name="siteAccessProblem" type="xs:string" minOccurs="0" maxOccurs="1"

```

```

sawsdl:modelReference="http://iec.ch/TC57/CIM-generic#ServiceLocation.siteAccessProblem">
  <xs:annotation>
    <xs:documentation>Problems previously encountered when visiting or
performing work on this location. Examples include: bad dog, violent customer, verbally abusive occupant, obstructions, safety
hazards, etc.</xs:documentation>
  </xs:annotation>
</xs:element>
<xs:element name="CoordinateSystem" minOccurs="0" maxOccurs="1"
sawsdl:modelReference="http://iec.ch/TC57/CIM-generic#Location.CoordinateSystem">
  <xs:annotation>
    <xs:documentation>Coordinate system used to describe position points of
this location.</xs:documentation>
  </xs:annotation>
  <xs:complexType sawsdl:modelReference="http://iec.ch/TC57/CIM-
generic#CoordinateSystem">
    <xs:sequence>
      <xs:element name="crsUrn" type="xs:string" minOccurs="1"
maxOccurs="1" sawsdl:modelReference="http://iec.ch/TC57/CIM-generic#CoordinateSystem.crsUrn">
        <xs:annotation>
          <xs:documentation>A Uniform Resource
Name (URN) for the coordinate reference system (crs) used to define 'Location.PositionPoints'.</xs:documentation>
          <xs:documentation>An example would be the
European Petroleum Survey Group (EPSG) code for a coordinate reference system, defined in URN under the Open Geospatial
Consortium (OGC) namespace as: urn:ogc:def:uom:EPSG::XXXX, where XXXX is an EPSG code (a full list of codes can be
found at the EPSG Registry web site http://www.epsg-registry.org/). To define the coordinate system as being WGS84 (latitude,
longitude) using an EPSG OGC, this attribute would be urn:ogc:def:uom:EPSG::4236.</xs:documentation>
          <xs:documentation>A profile should limit this
code to a set of allowed URNs agreed to by all sending and receiving parties.</xs:documentation>
        </xs:annotation>
      </xs:element>
    </xs:sequence>
  </xs:complexType>
</xs:element>
<xs:element name="Hazards" minOccurs="0" maxOccurs="unbounded"
sawsdl:modelReference="http://iec.ch/TC57/CIM-generic#Location.Hazards">
  <xs:annotation>
    <xs:documentation>All asset hazards at this location.</xs:documentation>
  </xs:annotation>
  <xs:complexType sawsdl:modelReference="http://www.w3.org/2002/07/owl#Thing">
    <xs:sequence>
      <xs:element name="type" type="xs:string" minOccurs="1"
maxOccurs="1" sawsdl:modelReference="http://iec.ch/TC57/CIM-generic#Hazard.type">
        <xs:annotation>
          <xs:documentation>Type of this
hazard.</xs:documentation>
        </xs:annotation>
      </xs:element>
    </xs:sequence>
  </xs:complexType>
</xs:element>
<xs:element name="mainAddress" minOccurs="0" maxOccurs="1"
sawsdl:modelReference="http://iec.ch/TC57/CIM-generic#Location.mainAddress">
  <xs:annotation>
    <xs:documentation>Main address of the location.</xs:documentation>
  </xs:annotation>
  <xs:complexType sawsdl:modelReference="http://iec.ch/TC57/CIM-
generic#StreetAddress">
    <xs:sequence>
      <xs:element name="streetDetail" minOccurs="0" maxOccurs="1"
sawsdl:modelReference="http://iec.ch/TC57/CIM-generic#StreetAddress.streetDetail">
        <xs:annotation>
          <xs:documentation>Street
detail.</xs:documentation>
        </xs:annotation>
      </xs:element>
    </xs:sequence>
  </xs:complexType>
  <xs:sequence>
    <xs:element
name="addressGeneral" type="xs:string" minOccurs="1" maxOccurs="1" sawsdl:modelReference="http://iec.ch/TC57/CIM-
generic#StreetDetail.addressGeneral">
      <xs:annotation>
        <xs:documentation>Additional address information, for example a mailstop.</xs:documentation>
      </xs:annotation>
    </xs:element>
    <xs:element name="buildingName"
type="xs:string" minOccurs="0" maxOccurs="1" sawsdl:modelReference="http://iec.ch/TC57/CIM-

```



```

generic#StreetDetail.buildingName">
</xs:annotation>
<xs:documentation>(if applicable) In certain cases the physical location of the place of interest does not have a direct
point of entry from the street, but may be located inside a larger structure such as a building, complex, office block, apartment,
etc.</xs:documentation>
</xs:annotation>
</xs:element>
<xs:element name="code"
type="xs:string" minOccurs="0" maxOccurs="1" sawsdl:modelReference="http://iec.ch/TC57/CIM-generic#StreetDetail.code">
</xs:annotation>
<xs:documentation>(if applicable) Utilities often make use of external reference systems, such as those of the town-
planner's department or surveyor general's mapping system, that allocate global reference codes to
streets.</xs:documentation>
</xs:annotation>
</xs:element>
<xs:element name="name"
type="xs:string" minOccurs="0" maxOccurs="1" sawsdl:modelReference="http://iec.ch/TC57/CIM-generic#StreetDetail.name">
</xs:annotation>
<xs:documentation>Name of the street.</xs:documentation>
</xs:annotation>
</xs:element>
<xs:element name="number"
type="xs:string" minOccurs="0" maxOccurs="1" sawsdl:modelReference="http://iec.ch/TC57/CIM-
generic#StreetDetail.number">
</xs:annotation>
<xs:documentation>Designator of the specific location on the street.</xs:documentation>
</xs:annotation>
</xs:element>
<xs:element name="prefix"
type="xs:string" minOccurs="0" maxOccurs="1" sawsdl:modelReference="http://iec.ch/TC57/CIM-generic#StreetDetail.prefix">
</xs:annotation>
<xs:documentation>Prefix to the street name. For example: North, South, East, West.</xs:documentation>
</xs:annotation>
</xs:element>
<xs:element name="suffix"
type="xs:string" minOccurs="0" maxOccurs="1" sawsdl:modelReference="http://iec.ch/TC57/CIM-generic#StreetDetail.suffix">
</xs:annotation>
<xs:documentation>Suffix to the street name. For example: North, South, East, West.</xs:documentation>
</xs:annotation>
</xs:element>
<xs:element name="suiteNumber"
type="xs:string" minOccurs="0" maxOccurs="1" sawsdl:modelReference="http://iec.ch/TC57/CIM-
generic#StreetDetail.suiteNumber">
</xs:annotation>
<xs:documentation>Number of the apartment or suite.</xs:documentation>
</xs:annotation>
</xs:element>
<xs:element name="type"
type="xs:string" minOccurs="0" maxOccurs="1" sawsdl:modelReference="http://iec.ch/TC57/CIM-generic#StreetDetail.type">
</xs:annotation>
<xs:documentation>Type of street. Examples include: street, circle, boulevard, avenue, road, drive,
etc.</xs:documentation>
</xs:annotation>
</xs:element>
<xs:element
name="withinTownLimits" type="xs:boolean" minOccurs="0" maxOccurs="1" sawsdl:modelReference="http://iec.ch/TC57/CIM-
generic#StreetDetail.withinTownLimits">
</xs:annotation>
<xs:documentation>True if this street is within the legal geographical boundaries of the specified town
(default).</xs:documentation>
</xs:annotation>
</xs:element>
</xs:sequence>
</xs:complexType>
</xs:element>
<xs:element name="townDetail" minOccurs="0" maxOccurs="1"
sawsdl:modelReference="http://iec.ch/TC57/CIM-generic#StreetAddress.townDetail">
</xs:annotation>

```



```

</xs:annotation>
</xs:element>
<xs:element name="zPosition" type="xs:string" minOccurs="1"
maxOccurs="1" sawsdl:modelReference="http://iec.ch/TC57/CIM-generic#PositionPoint.zPosition">
  <xs:annotation>
    <xs:documentation>(if applicable) Z axis
position.</xs:documentation>
  </xs:annotation>
</xs:element>
</xs:sequence>
</xs:complexType>
</xs:element>
</xs:sequence>
</xs:complexType>
<xs:complexType name="Status" sawsdl:modelReference="http://iec.ch/TC57/CIM-generic#Status">
  <xs:annotation>
    <xs:documentation>Current status information relevant to an entity.</xs:documentation>
  </xs:annotation>
  <xs:sequence>
    <xs:element name="dateTime" type="xs:dateTime" minOccurs="0" maxOccurs="1"
sawsdl:modelReference="http://iec.ch/TC57/CIM-generic#Status.dateTime">
      <xs:annotation>
        <xs:documentation>Date and time for which status 'value'
applies.</xs:documentation>
      </xs:annotation>
    </xs:element>
    <xs:element name="reason" type="xs:string" minOccurs="0" maxOccurs="1"
sawsdl:modelReference="http://iec.ch/TC57/CIM-generic#Status.reason">
      <xs:annotation>
        <xs:documentation>Reason code or explanation for why an object went to
the current status 'value'.</xs:documentation>
      </xs:annotation>
    </xs:element>
    <xs:element name="remark" type="xs:string" minOccurs="0" maxOccurs="1"
sawsdl:modelReference="http://iec.ch/TC57/CIM-generic#Status.remark">
      <xs:annotation>
        <xs:documentation>Pertinent information regarding the current 'value', as
free form text.</xs:documentation>
      </xs:annotation>
    </xs:element>
    <xs:element name="value" type="xs:string" minOccurs="0" maxOccurs="1"
sawsdl:modelReference="http://iec.ch/TC57/CIM-generic#Status.value">
      <xs:annotation>
        <xs:documentation>Status value at 'dateTime'; prior status changes may
have been kept in instances of activity records associated with the object to which this status applies.</xs:documentation>
      </xs:annotation>
    </xs:element>
  </xs:sequence>
</xs:complexType>
<xs:complexType name="WorkTask" sawsdl:modelReference="http://iec.ch/TC57/CIM-generic#WorkTask">
  <xs:annotation/>
  <xs:sequence>
    <xs:element name="mRID" type="xs:string" minOccurs="0" maxOccurs="1"
sawsdl:modelReference="http://iec.ch/TC57/CIM-generic#IdentifiedObject.mRID">
      <xs:annotation>
        <xs:documentation>Master resource identifier issued by a model authority.
The mRID must semantically be a UUID as specified in RFC 4122. The mRID is globally unique.</xs:documentation>
        <xs:documentation>For CIMXML data files in RDF syntax, the mRID is
mapped to rdf:ID or rdf:about attributes that identify CIM object elements.</xs:documentation>
      </xs:annotation>
    </xs:element>
    <xs:element name="subject" type="xs:string" minOccurs="1" maxOccurs="1"
sawsdl:modelReference="http://iec.ch/TC57/CIM-generic#Document.subject">
      <xs:annotation>
        <xs:documentation>Document subject.</xs:documentation>
      </xs:annotation>
    </xs:element>
    <xs:element name="Crews" minOccurs="0" maxOccurs="unbounded"
sawsdl:modelReference="http://iec.ch/TC57/CIM-generic#WorkTask.Crews">
      <xs:annotation>
        <xs:documentation>All crews participating in this work
task.</xs:documentation>
      </xs:annotation>
    </xs:element>
  </xs:sequence>
</xs:complexType>
<xs:sequence>
  <xs:element name="mRID" type="xs:string" minOccurs="0"
maxOccurs="1" sawsdl:modelReference="http://iec.ch/TC57/CIM-generic#IdentifiedObject.mRID">

```



```

generic#WorkTimeScheduleKind">
    <xs:simpleType sawsdl:modelReference="http://iec.ch/TC57/CIM-
        <xs:restriction base="xs:string">
            <xs:enumeration value="actual">
                <xs:annotation/>
            </xs:enumeration>
            <xs:enumeration value="earliest">
                <xs:annotation/>
            </xs:enumeration>
            <xs:enumeration value="estimate">
                <xs:annotation/>
            </xs:enumeration>
            <xs:enumeration value="latest">
                <xs:annotation/>
            </xs:enumeration>
            <xs:enumeration value="request">
                <xs:annotation/>
            </xs:enumeration>
        </xs:restriction>
    </xs:simpleType>
</xs:element>
<xs:element name="scheduleInterval" minOccurs="1" maxOccurs="1"
sawsdl:modelReference="http://iec.ch/TC57/CIM-generic#TimeSchedule.scheduleInterval">
    <xs:annotation>
        <xs:documentation>Schedule date and time interval.</xs:documentation>
    </xs:annotation>
    <xs:complexType sawsdl:modelReference="http://iec.ch/TC57/CIM-
        generic#DateTimeInterval">
        <xs:sequence>
            <xs:element name="end" type="xs:dateTime" minOccurs="1"
maxOccurs="1" sawsdl:modelReference="http://iec.ch/TC57/CIM-generic#DateTimeInterval.end">
                <xs:annotation>
                    <xs:documentation>End date and time of this
interval.</xs:documentation>
                </xs:annotation>
            </xs:element>
            <xs:element name="start" type="xs:dateTime" minOccurs="1"
maxOccurs="1" sawsdl:modelReference="http://iec.ch/TC57/CIM-generic#DateTimeInterval.start">
                <xs:annotation>
                    <xs:documentation>Start date and time of this
interval.</xs:documentation>
                </xs:annotation>
            </xs:element>
        </xs:sequence>
    </xs:complexType>
</xs:element>
</xs:sequence>
</xs:complexType>
</xs:schema>

```

Figure A.4 – Service request XSD

## Bibliography

IEC 60050-300, *International Electrotechnical Vocabulary – Electrical and electronic measurements and measuring instruments – Part 311: General terms relating to measurements – Part 312: General terms relating to electrical measurements – Part 313: Types of electrical measuring instruments – Part 314: Specific terms according to the type of instrument*

---



# British Standards Institution (BSI)

BSI is the national body responsible for preparing British Standards and other standards-related publications, information and services.

BSI is incorporated by Royal Charter. British Standards and other standardization products are published by BSI Standards Limited.

## About us

We bring together business, industry, government, consumers, innovators and others to shape their combined experience and expertise into standards-based solutions.

The knowledge embodied in our standards has been carefully assembled in a dependable format and refined through our open consultation process. Organizations of all sizes and across all sectors choose standards to help them achieve their goals.

## Information on standards

We can provide you with the knowledge that your organization needs to succeed. Find out more about British Standards by visiting our website at [bsigroup.com/standards](http://bsigroup.com/standards) or contacting our Customer Services team or Knowledge Centre.

## Buying standards

You can buy and download PDF versions of BSI publications, including British and adopted European and international standards, through our website at [bsigroup.com/shop](http://bsigroup.com/shop), where hard copies can also be purchased.

If you need international and foreign standards from other Standards Development Organizations, hard copies can be ordered from our Customer Services team.

## Copyright in BSI publications

All the content in BSI publications, including British Standards, is the property of and copyrighted by BSI or some person or entity that owns copyright in the information used (such as the international standardization bodies) and has formally licensed such information to BSI for commercial publication and use.

Save for the provisions below, you may not transfer, share or disseminate any portion of the standard to any other person. You may not adapt, distribute, commercially exploit, or publicly display the standard or any portion thereof in any manner whatsoever without BSI's prior written consent.

## Storing and using standards

Standards purchased in soft copy format:

- A British Standard purchased in soft copy format is licensed to a sole named user for personal or internal company use only.
- The standard may be stored on more than 1 device provided that it is accessible by the sole named user only and that only 1 copy is accessed at any one time.
- A single paper copy may be printed for personal or internal company use only.

Standards purchased in hard copy format:

- A British Standard purchased in hard copy format is for personal or internal company use only.
- It may not be further reproduced – in any format – to create an additional copy. This includes scanning of the document.

If you need more than 1 copy of the document, or if you wish to share the document on an internal network, you can save money by choosing a subscription product (see 'Subscriptions').

## Reproducing extracts

For permission to reproduce content from BSI publications contact the BSI Copyright & Licensing team.

## Subscriptions

Our range of subscription services are designed to make using standards easier for you. For further information on our subscription products go to [bsigroup.com/subscriptions](http://bsigroup.com/subscriptions).

With **British Standards Online (BSOL)** you'll have instant access to over 55,000 British and adopted European and international standards from your desktop. It's available 24/7 and is refreshed daily so you'll always be up to date.

You can keep in touch with standards developments and receive substantial discounts on the purchase price of standards, both in single copy and subscription format, by becoming a **BSI Subscribing Member**.

**PLUS** is an updating service exclusive to BSI Subscribing Members. You will automatically receive the latest hard copy of your standards when they're revised or replaced.

To find out more about becoming a BSI Subscribing Member and the benefits of membership, please visit [bsigroup.com/shop](http://bsigroup.com/shop).

With a **Multi-User Network Licence (MUNL)** you are able to host standards publications on your intranet. Licences can cover as few or as many users as you wish. With updates supplied as soon as they're available, you can be sure your documentation is current. For further information, email [subscriptions@bsigroup.com](mailto:subscriptions@bsigroup.com).

## Revisions

Our British Standards and other publications are updated by amendment or revision.

We continually improve the quality of our products and services to benefit your business. If you find an inaccuracy or ambiguity within a British Standard or other BSI publication please inform the Knowledge Centre.

## Useful Contacts

### Customer Services

**Tel:** +44 345 086 9001

**Email (orders):** [orders@bsigroup.com](mailto:orders@bsigroup.com)

**Email (enquiries):** [cservices@bsigroup.com](mailto:cservices@bsigroup.com)

### Subscriptions

**Tel:** +44 345 086 9001

**Email:** [subscriptions@bsigroup.com](mailto:subscriptions@bsigroup.com)

### Knowledge Centre

**Tel:** +44 20 8996 7004

**Email:** [knowledgecentre@bsigroup.com](mailto:knowledgecentre@bsigroup.com)

### Copyright & Licensing

**Tel:** +44 20 8996 7070

**Email:** [copyright@bsigroup.com](mailto:copyright@bsigroup.com)

### BSI Group Headquarters

389 Chiswick High Road London W4 4AL UK