

BS EN 61938:2013



BSI Standards Publication

Multimedia systems — Guide to the recommended characteristics of analogue interfaces to achieve interoperability

bsi.

...making excellence a habit.™

National foreword

This British Standard is the UK implementation of EN 61938:2013. It is identical to IEC 61938:2013. It supersedes BS EN 61938:1997 which is withdrawn.

The UK participation in its preparation was entrusted to Technical Committee EPL/100, Audio, video and multimedia systems and equipment.

A list of organizations represented on this committee can be obtained on request to its secretary.

This publication does not purport to include all the necessary provisions of a contract. Users are responsible for its correct application.

© The British Standards Institution 2013.
Published by BSI Standards Limited 2013

ISBN 978 0 580 84038 8
ICS 33.160.60; 35.200

Compliance with a British Standard cannot confer immunity from legal obligations.

This British Standard was published under the authority of the Standards Policy and Strategy Committee on 30 September 2013.

Amendments/corrigenda issued since publication

Date	Text affected
-------------	----------------------

English version

**Multimedia systems -
Guide to the recommended characteristics
of analogue interfaces to achieve interoperability
(IEC 61938:2013)**

Systemes multimédia -
Guide des caractéristiques
recommandées des interfaces
analogiques permettant d'obtenir
l'interopérabilité
(CEI 61938:2013)

Multimedia Systeme -
Leitfaden für empfohlene Charakteristiken
analoger Schnittstellen zur Erreichung von
Kompatibilität
(IEC 61938:2013)

This European Standard was approved by CENELEC on 2013-08-01. CENELEC members are bound to comply with the CEN/CENELEC Internal Regulations which stipulate the conditions for giving this European Standard the status of a national standard without any alteration.

Up-to-date lists and bibliographical references concerning such national standards may be obtained on application to the CEN-CENELEC Management Centre or to any CENELEC member.

This European Standard exists in three official versions (English, French, German). A version in any other language made by translation under the responsibility of a CENELEC member into its own language and notified to the CEN-CENELEC Management Centre has the same status as the official versions.

CENELEC members are the national electrotechnical committees of Austria, Belgium, Bulgaria, Croatia, Cyprus, the Czech Republic, Denmark, Estonia, Finland, Former Yugoslav Republic of Macedonia, France, Germany, Greece, Hungary, Iceland, Ireland, Italy, Latvia, Lithuania, Luxembourg, Malta, the Netherlands, Norway, Poland, Portugal, Romania, Slovakia, Slovenia, Spain, Sweden, Switzerland, Turkey and the United Kingdom.

CENELEC

European Committee for Electrotechnical Standardization
Comité Européen de Normalisation Electrotechnique
Europäisches Komitee für Elektrotechnische Normung

CEN-CENELEC Management Centre: Avenue Marnix 17, B - 1000 Brussels

Foreword

The text of document 100/2130/FDIS, future edition 2 of IEC 61938, prepared by IEC/TC 100 "Audio, video and multimedia systems and equipment" was submitted to the IEC-CENELEC parallel vote and approved by CENELEC as EN 61938:2013.

The following dates are fixed:

- latest date by which the document has to be implemented at national level by publication of an identical national standard or by endorsement (dop) 2014-05-01
- latest date by which the national standards conflicting with the document have to be withdrawn (dow) 2016-08-01

This document supersedes EN 61938:1997.

EN 61938:2013 includes the following significant technical changes with respect to EN 61938:1997:

- the main title was changed to: Multimedia systems - Guide to the recommended characteristics of analogue interfaces to achieve interoperability;
- the scope was adapted to the title;
- a new introduction has been added. The necessity of the above revisions is mentioned in this introduction;
- the values in each table were chosen with respect to the state of the art and representative of best practice in industry;
- plug-in power systems and soundcard power systems are added;
- a new Subclause 12.3 has been created: Interoperability of portable audio headphones /earphones and portable audio equipment;
- a new Annex A describing pairing and screening of conductors is added;
- a new Annex B describing phantom power variants for specialized applications is also added.

Attention is drawn to the possibility that some of the elements of this document may be the subject of patent rights. CENELEC [and/or CEN] shall not be held responsible for identifying any or all such patent rights.

Endorsement notice

The text of the International Standard IEC 61938:2013 was approved by CENELEC as a European Standard without any modification.

In the official version, for Bibliography, the following notes have to be added for the standards indicated:

IEC 60027 Series	NOTE	Harmonised as EN 60027 Series (not modified).
IEC 61293:1994	NOTE	Harmonised as EN 61293:1994 (not modified).

Annex ZA (normative)

Normative references to international publications with their corresponding European publications

The following documents, in whole or in part, are normatively referenced in this document and are indispensable for its application. For dated references, only the edition cited applies. For undated references, the latest edition of the referenced document (including any amendments) applies.

NOTE When an international publication has been modified by common modifications, indicated by (mod), the relevant EN/HD applies.

<u>Publication</u>	<u>Year</u>	<u>Title</u>	<u>EN/HD</u>	<u>Year</u>
IEC 60038 (mod)	2009	IEC standard voltages	EN 60038	2011
IEC 60094-2 + corr. March	1994 1995	Magnetic tape sound recording and reproducing systems - Part 2: Calibration tapes	EN 60094-2	1995
IEC 60107-6	1989	Recommended methods of measurement on receivers for television broadcast transmissions - Part 6: Measurements under conditions different from broadcast signal standards	HD 567.6 S1	1990
IEC 60130-9	2011	Connectors for frequencies below 3 MHz - Part 9: Circular connectors for radio and associated sound equipment	EN 60130-9	2011
IEC 60268-1 + A1 + A2	1985 1988 1988	Sound system equipment - Part 1: General	HD 483.1 S2 - ¹⁾ -	1989 - -
IEC 60268-3	2000	Sound system equipment - Part 3: Amplifiers	EN 60268-3 + corr. January ²⁾	2000 2002
IEC 60268-5 + A1	2003 2007	Sound system equipment - Part 5: Loudspeakers	EN 60268-5 + A1	2003 2009
IEC 60268-7	2010	Sound system equipment - Part 7: Headphones and earphones	EN 60268-7	2011
IEC 60268-11 + A1 + A2	1987 1989 1991	Sound system equipment - Part 11: Application of connectors for the interconnection of sound system components	HD 483.11 S3 - - ³⁾	1993 - -
IEC 60268-12 + A1 + A2	1987 1991 1994	Sound system equipment - Part 12: Application of connectors for broadcast and similar use	EN 60268-12 - ⁴⁾ + A2	1995 - 1995
IEC 60603-11	1992	Connectors for frequencies below 3 MHz for use with printed boards - Part 11: Detail specification for concentric connectors (dimensions for free connectors and fixed connectors)	-	-

¹⁾ HD 483.1 S2 includes A1 to IEC 60268-1.

²⁾ EN 60268-3 is superseded by EN 60268-3:2013, which is based on IEC 60268-3:2013.

³⁾ HD 483.11 S3 includes A1 + A2 to IEC 60268-11.

⁴⁾ EN 60268-12 includes A1 to IEC 60268-12.

<u>Publication</u>	<u>Year</u>	<u>Title</u>	<u>EN/HD</u>	<u>Year</u>
IEC 60958	Series	Digital audio interface	EN 60958	Series
ITU-R BT.1700	2005	Characteristics of composite video signals for conventional analogue television systems	-	-

CONTENTS

INTRODUCTION.....	7
1 Scope.....	8
2 Normative references	10
3 Terms and definitions	10
4 General conditions.....	13
5 Power supply.....	13
5.1 Alternating current (a.c.) power supply voltages and frequencies	13
5.2 Direct current (d.c.) power supply voltages	13
5.3 Power supply feed for microphones	14
6 Interconnections	14
6.1 Connections	14
6.1.1 General	14
6.1.2 Characteristics of cables	14
6.2 Connectors.....	15
7 Marking and symbols for marking	16
7.1 Marking	16
7.2 Symbols for marking.....	16
8 Electrical recommended values	16
8.1 General purpose output/input.....	16
8.2 General purpose audio output/input.....	16
8.2.1 Audio-only interfaces for consumer equipment.....	16
8.2.2 Interfaces for professional equipment and consumer equipment where audio and video signals are present on the same connector or cable	18
8.3 General purpose video input/output.....	19
9 Interoperability of microphones and amplifiers	19
9.1 Microphones (excluding piezoelectric types)	19
9.2 Power supply feed for electret microphones fed over a signal conductor ("plug-in power").....	20
9.3 Power supply feed for electret microphones fed by a separate conductor ("soundcard power" or "PC power")	21
9.4 Phantom supply system	21
9.4.1 General	21
9.4.2 Supply voltage polarity	22
9.4.3 Circuit diagram	22
9.4.4 Value of the supply voltage	22
9.4.5 Supply current	22
9.4.6 Marking	22
9.5 A-B supply system	23
9.5.1 General	23
9.5.2 Output impedance of the microphone.....	23
9.5.3 Circuit diagram	23
9.5.4 Connection of the power supply to earth	23
9.5.5 Marking	23
9.6 Polarity of the audio frequency voltage	23

10	Interoperability of record-playing units (pick-ups) and amplifiers	26
11	Interoperability of loudspeakers and amplifiers	26
11.1	Single unit loudspeakers	26
11.2	Loudspeaker systems	26
11.2.1	Loudspeakers with built-in amplifier	26
11.2.2	Impedance-defined loudspeaker systems	27
11.2.3	Constant voltage loudspeaker systems	27
11.3	Voltage (or power) interoperability of amplifiers and loudspeakers	27
11.3.1	Overview	27
11.3.2	Interoperability requirements	28
11.4	Polarity of the sound pressure	28
12	Interoperability of headphones and amplifiers	28
12.1	General	28
12.2	Interoperability of headphones with stationary amplifiers	28
12.3	Interoperability of portable audio headphones/earphones and portable audio equipment	29
12.3.1	General	29
12.3.2	Portable audio headphones/earphones	29
12.3.3	Portable audio equipment	29
12.3.4	Recommended values and input/output values for portable audio headphones/earphones and portable audio equipment	29
13	Interoperability of amplifiers with other amplifiers	30
13.1	Pre-amplifiers and power amplifiers for general purpose and sound reinforcement	30
13.2	Broadcast and similar line amplifiers	31
Annex A (informative)	Pairing and screening of conductors	32
Annex B (informative)	Phantom power variants for specialized applications	33
Bibliography	34
Figure 1	– Audio and video sources and destinations	9
Figure 2	– Example of plug-in power system for a single microphone	24
Figure 3	– Example of plug-in power system for a two-channel microphone	24
Figure 4	– Example of soundcard power system	24
Figure 5	– Example of phantom power supply system	25
Figure 6	– Example of A-B power supply system	25
Table 1	– Direct current (d.c.) power supply voltages and tolerances	14
Table 2	– General purpose values for audio-only interfaces	16
Table 3	– General purpose values for audio signals for professional interfaces	18
Table 4	– General purpose recommended values for video signals	19
Table 5	– Recommended values for microphones and amplifiers	20
Table 6	– Required values for phantom supply systems	25
Table 7	– Required values for A-B power supply systems	25
Table 8	– Recommended values for analogue record-playing units and amplifiers	26
Table 9	– Recommended values for impedance-defined loudspeaker systems	27
Table 10	– Recommended values for constant voltage loudspeaker systems	27

Table 11 – Recommended values for headphones and amplifiers in stationary applications	29
Table 12 – Recommended values for portable audio headphones/earphones and portable audio equipment	30
Table 13 – Recommended values for pre-amplifiers and power amplifiers	31
Table 14 – Recommended values for broadcast and similar line amplifiers	31

INTRODUCTION

The first edition of IEC 61938 was derived from IEC 60268-15, IEC 60574-4 and IEC 60933-1 and also from related proposals which had been submitted up until the date of this revision. IEC 60268-15 was the first standard to address 'interoperability' – the ability of equipment from different manufacturers to be assembled into a system with full compatibility at every 'interface'. However, the purpose, terminology and implications of IEC 61938 are now widely misunderstood because the words 'matching' and 'preferred' used in IEC 61938, are frequently misinterpreted, resulting in IEC 61938 being regarded as a performance standard, which was never its intention. The aim of this revision is to make the intention of this standard easily comprehensible by using widely used terminology in the title and text of the standard.

The features of the revision are the following.

- a) Unification and arrangement of existing related standards, including effective proposals which have been submitted.
- b) The concept of "general purpose input/output".

NOTE The standard numbers mentioned above correspond to the revised numbers, if applicable.

MULTIMEDIA SYSTEMS – GUIDE TO THE RECOMMENDED CHARACTERISTICS OF ANALOGUE INTERFACES TO ACHIEVE INTEROPERABILITY

1 Scope

This International Standard gives guidance on current practice for the characteristics of multimedia analogue interfaces to achieve interoperability between equipment from different manufacturers. It is not a performance standard.

Recommendations for interfaces for equipment used in vehicles, and for analogue video interfaces for broadcast and similar equipment, are not given.

Refer to IEC 60958 for the interconnection of digital signals.

Figure 1 shows in a diagram the possible interfaces of the audio and video sources and destinations.

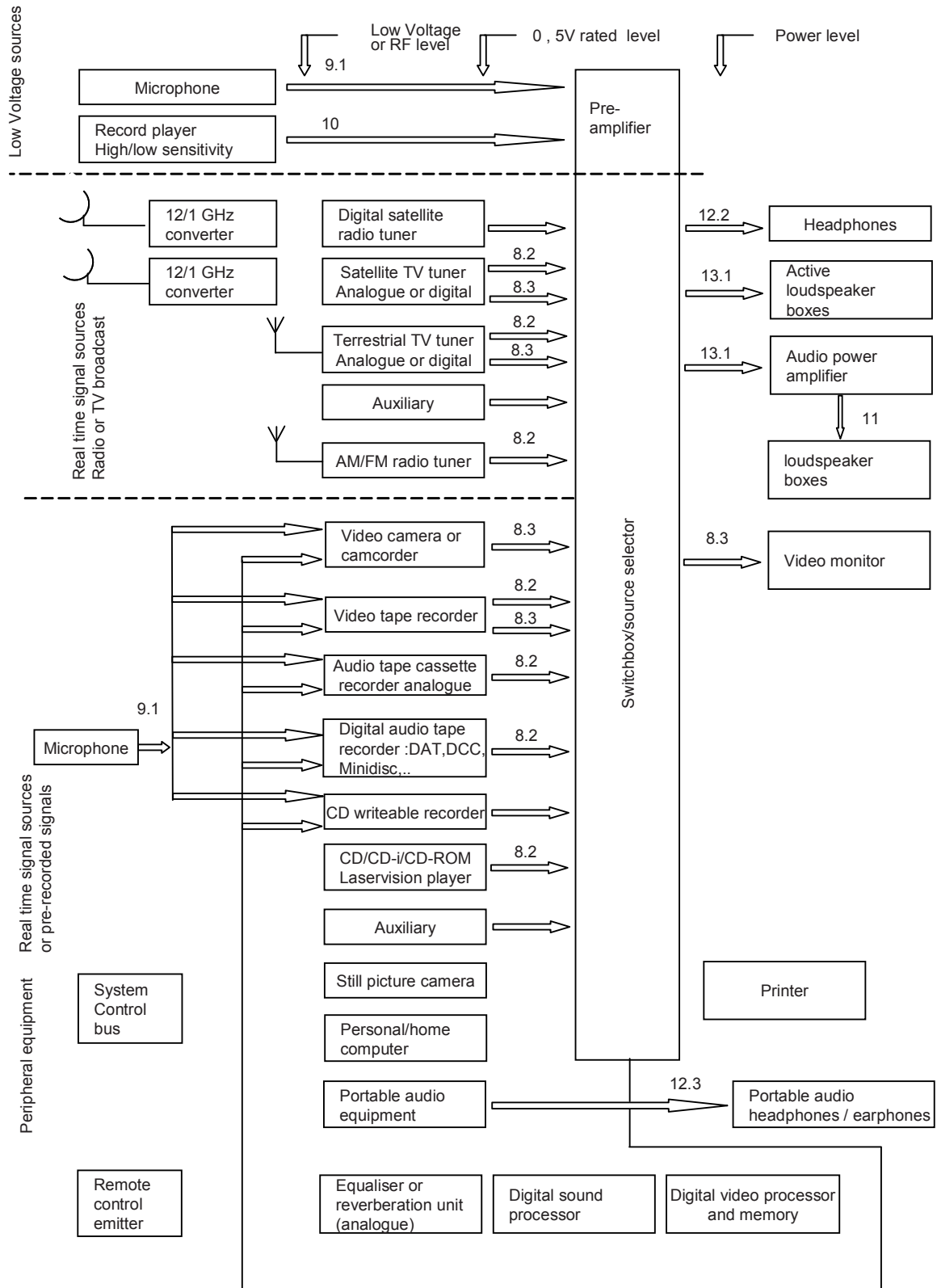

IEC 1298/13

NOTE The numbers indicated above the arrows refer to the appropriate clause or subclauses of this standard.

Figure 1 – Audio and video sources and destinations

2 Normative references

The following documents, in whole or in part, are normatively referenced in this document and are indispensable for its application. For dated references, only the edition cited applies. For undated references, the latest edition of the referenced document (including any amendments) applies.

IEC 60038:2009, *IEC standard voltages*

IEC 60094-2:1994, *Magnetic tape recording and reproducing systems – Part 2: Calibration tapes*

IEC 60107-6:1989, *Recommended methods of measurement on receivers for television broadcast transmissions – Part 6: Measurements under conditions different from broadcast signal standards*

IEC 60130-9:2011, *Connectors for frequencies below 3 MHz – Part 9: Circular connectors for radio and associated sound equipment*

IEC 60268-1:1985, *Sound system equipment – Part 1: General*
Amendment 1:1988
Amendment 2:1988

IEC 60268-3:2000, *Sound system equipment – Part 3: Amplifiers*

IEC 60268-5:2003, *Sound system equipment – Part 5: Loudspeakers*
Amendment 1:2007

IEC 60268-7:2010, *Sound system equipment – Part 7: Headphones and earphones*

IEC 60268-11:1987, *Sound system equipment – Part 11: Application of connectors for the interconnection of sound system components*
Amendment 1:1989
Amendment 2:1991

IEC 60268-12:1987, *Sound system equipment – Part 12: Application of connectors for broadcast and similar use*
Amendment 1:1991
Amendment 2:1994

IEC 60603-11:1992, *Connectors for frequencies below 3 MHz for use with printed boards – Part 11: Detail specification for concentric connectors (dimensions for free connectors and fixed connectors)*

IEC 60958 (all parts), *Digital audio interface*

ITU-R BT.1700:2005, *Characteristics of composite video signals for conventional analogue television systems*

3 Terms and definitions

For the purposes of this document, the following terms and definitions apply.

3.1

luminance signal

electrical signal representing the luminance of the television picture elements

[SOURCE: IEC 60050-723:1997, 723-05-56, modified, Note has been deleted]

3.2

chrominance signal

electrical signal that is associated with the luminance signal to convey colour information; in practice this signal is made up of two components

[SOURCE: IEC 60050-723:1997, 723-05-57]

3.3

Y" signal

CVBS signal

combined signal consisting of

- a luminance signal;
- blanking and synchronizing signals

Note 1 to entry: The Y" signal is the composite video signal (CVBS signal) without the C" signal.

3.4

colour signal

C" signal

chrominance signal with burst signal included, modulated on a subcarrier

3.5

composite video signal

CVS signal

combined signal consisting of

- a luminance signal;
- a colour signal

3.6

composite video, blanking and synchronization signal

CVBS signal

combined signal consisting of

- a luminance signal;
- a colour signal;
- blanking and synchronizing signals

3.7

blanking signal

signal used to control the suppression of the signal conveying picture information during certain parts of the scanning period, for example, during fly-back

[SOURCE: IEC 60050:1997, 723-05-37, modified, Example has been deleted]

3.8

synchronizing signal

signal used to determine the timing for the scanning processes in transmission and reception

[SOURCE: IEC 60050:1997, 723-05-36]

3.9 interface

shared boundary between two pieces of equipment, defined by functional characteristics, common physical interconnection characteristics, signal characteristics and other characteristics, as appropriate

[SOURCE: ISO/IEC 2382-9:1995, definition 09.01.06, modified, definition has been adapted]

3.10 minimum output voltage

voltage measured across the rated load impedance of a piece of equipment, and related to a minimum input signal limited by signal to noise ratio

3.11 maximum output voltage

voltage measured across the rated load impedance of a piece of equipment and related to a maximum input signal limited by non-linearity

3.12 rated source impedance

internal impedance, stated by the manufacturer, of the source supplying the signal to the piece of equipment

Note 1 to entry: Unless otherwise specified, the rated source impedance is assumed to be a constant pure resistance.

Note 2 to entry: The manufacturer may also give the range of source impedances which he considers tolerable in practice.

Note 3 to entry: Multiple values, or a range of values, may be specified, providing the corresponding rated (distortion-limited) output voltages and/or powers are also stated.

3.13 input impedance

internal impedance measured between the input terminal and its corresponding return of the piece of equipment

3.14 rated source e.m.f.

e.m.f. specified by the manufacturer which, when connected to the input terminals in series with the rated source impedance, gives rated distortion-limited output voltage across the rated load impedance at an appropriate setting of the controls

3.15 minimum source e.m.f. for rated output voltage

e.m.f. which, when connected to the input terminals in series with the rated source impedance, gives rated output voltage across the rated load impedance with the volume control(s), if any, set for maximum gain and the tone control(s), if any, set as specified for rated conditions

3.16 rated load impedance

impedance, specified by the manufacturer, to which the output terminals are to be connected for measuring purposes

Note 1 to entry: Unless otherwise specified by the manufacturer, the rated load impedance shall be assumed to be a constant pure resistance.

Note 2 to entry: Multiple values, or a range of values, may be specified, provided the corresponding rated (distortion-limited) output voltages and/or powers are also stated.

3.17

output source impedance

internal impedance measured between the output terminal and its corresponding return under specified conditions

3.18

rated output voltage

voltage specified by the manufacturer, measured across the rated load-impedance of a piece of equipment

3.19

overload source e.m.f.

maximum source e.m.f. for which a piece of equipment, connected as for rated conditions and with an appropriate setting of the volume control, can deliver an output voltage 10 dB below the rated distortion limited output voltage without exceeding the rated total harmonic distortion

3.20

externally powered microphone

microphone containing internal active circuitry that obtains its operating power from an external device to which it is connected

3.21

powered input

point on a device at which an externally powered microphone may be connected

Note 1 to entry: This is a terminal which serves as an input for signals from a microphone and also as an output for power to the microphone.

4 General conditions

All voltages are r.m.s. voltages, unless otherwise indicated.

Impedances of audio circuits are valid in the frequency range of 20 Hz to 20 kHz, unless otherwise indicated.

Tables containing tolerances indicate that the equipment should operate over the entire range of possible values, but may not meet all of its specifications at the given limits.

5 Power supply

5.1 Alternating current (a.c.) power supply voltages and frequencies

For a.c. power supply voltages and frequencies, refer to IEC 60038.

For special applications, for example ships and aircraft, other voltages and/or frequencies and the permissible tolerances are subject to agreement between manufacturers and users.

5.2 Direct current (d.c.) power supply voltages

DC power supply voltages and the permissible tolerances are given in Table 1. The equipment should operate over the range of voltages given, but may not necessarily meet all of its specifications at the given limits.

Table 1 – Direct current (d.c.) power supply voltages and tolerances

Type of power supply	Rated voltage/cell V	Operating voltage/cell V		
		Lower limit	Normal voltage	Upper limit
Primary batteries				
– Alkali-manganese, zinc chloride-zinc	1,5	1,0	1,5	1,65
– Lithium (organic electrolyte)	3,0	2,0	3,0	3,7
Secondary batteries:				
– Lead-acid, except vehicle batteries	2,0	1,8	2,0	2,2
– Lead-acid, vehicle batteries	2,0	1,8	2,4	2,6
– Nickel-cadmium	1,2	1,1	1,2	1,4

5.3 Power supply feed for microphones

Refer to to 9.3, 9.4, and 9.5.

6 Interconnections

6.1 Connections

6.1.1 General

Signal cables shall have the appropriate electrical characteristics to permit the transfer of signals between the parts of a system without unacceptable impairment.

NOTE The degree of impairment which is unacceptable depends on the system specification and the need to comply with other international standards, such as those concerning electromagnetic compatibility.

6.1.2 Characteristics of cables

6.1.2.1 General

The following characteristics of cables should be taken into account.

6.1.2.2 Resistance of the conductors

A resistance of less than one-hundredth of the load impedance is usually acceptable for loudspeaker connections. For other applications, values of one-tenth are acceptable.

NOTE Long cables may therefore require conductors of a larger cross-sectional area than those of short cables.

6.1.2.3 Insulation resistance

An insulation resistance of 50 M Ω is usually acceptable.

6.1.2.4 Magnetic and electromagnetic interference susceptibility of interconnections

The use of untwisted pairs or single conductors with separate return paths is a common source of magnetic and electromagnetic interference at both audio and radio frequencies, especially for loudspeaker wiring, and should be avoided. A description of the methods of avoiding such interference is given in Annex A.

6.1.2.5 Reactance of conductors

The acceptable values vary too widely to give more than general guidance. The cable should not appreciably affect the signal being carried. In the absence of particular requirements, the inductive reactance of the cable should not cause more than 1 dB change in response over the frequency range of interest. The capacitive reactance between the two conductors of a signal-carrying pair, or a coaxial cable, in parallel with the load impedance, should be greater than the rated load impedance, at the highest frequency of interest.

While it is not recommended to use cables in which single conductors carry different audio signals, the capacitive reactance between conductors in this case should exceed 1 000 times the load impedance at the highest frequency of interest.

6.1.2.6 Capacitance from conductor to screen

The acceptable value varies too widely to give more than general guidance. In the absence of particular requirements, the capacitive reactance of a coaxial cable, in parallel with the load impedance, should be greater than the rated load impedance. The capacitance between each conductor of a balanced pair and its screen should be equal within 7,5 %. A closer tolerance is desirable.

NOTE The 7,5 % tolerance, which can be achieved using normal cable manufacturing methods, ensures preservation of adequate common mode rejection in balanced circuits (see Whitlock, JAES, 1995-06). The electromagnetic interference rejection of such circuits is dependent on impedance balance.

6.1.2.7 Characteristic impedance

This is usually only important for high-frequency signals (such as digital signals in accordance with IEC 60958).

6.1.2.8 Continuity of screening

In some applications, the screen is connected to contacts of connectors at both ends of the cable. In other cases, the screen is connected at one end of the cable only. When the screen of a balanced cable is interrupted, for example to prevent the flow of circulating currents, such interruption should be at the receiving end of the signal path. The screen of a coaxial cable should not be interrupted. Connections between equipment should comply with the requirements of AES48.

The screening of signal cables and connectors shall not be used as a means for the preservation of safety earth continuity for the prevention of electric shock hazard.

6.1.2.9 Efficiency of screening

The use of screening is meant to reduce the unwanted effects of electromagnetic disturbances, such as:

- a) in reducing crosstalk between conductors in the same cable;
- b) in reducing emission of unwanted signals from the cable;
- c) in maintaining immunity from external signals entering via the cable.

NOTE These characteristics are related, but good performance in one respect does not ensure good performance in another.

6.2 Connectors

For connectors used within the system, refer to the International Standards cited in Clause 2.

7 Marking and symbols for marking

7.1 Marking

Terminals and controls shall be adequately marked to give information regarding their function, characteristics and polarity.

The marking shall be such that it is possible to adjust the controls and to identify their positions with sufficient accuracy in connection with the information given in the user instructions.

7.2 Symbols for marking

Marking preferably should be composed of letter symbols, signs, numbers and colours, which are internationally intelligible. Refer to IEC 60027, IEC 60417, IEC 60617 and IEC 61293 for such symbols of marking.

Markings not included in the above-mentioned standards shall be clearly explained in the user instructions.

8 Electrical recommended values

8.1 General purpose output/input

In order to preserve the maximum flexibility of use and compatibility in the design of equipment, all inputs of destination equipment, and all outputs of source equipment for general applications shall have the same specifications. These are termed "general purpose input/output".

The manufacturer may choose to designate some or all of these input/outputs for particular purposes. For example, the general purpose input/output for audio signal would be designated for tuner, for tape recorder, or for auxiliary input, in order to simplify the operation, but the specification of all such inputs and outputs nevertheless shall be identical.

8.2 General purpose audio output/input

8.2.1 Audio-only interfaces for consumer equipment

Table 2 gives the values for audio-only interfaces.

Table 2 – General purpose values for audio-only interfaces

Output ^a		Input	
	Recommended values		Recommended values
Output source impedance	≤2,2 kΩ	Rated source impedance	2,2 kΩ
Rated load impedance	22 kΩ	Input impedance	≥22 kΩ
Rated output voltage	0,5 V ^b	Rated source e.m.f.	0,5 V ^e
Minimum output voltage	0,2 V ^c	Minimum source e.m.f. for rated output voltage	0,2 V
Maximum output voltage	2 V ^d	Overload source e.m.f.	≥2,8 V ^f
^a The output voltages are measured with the rated load impedance connected. ^b The value corresponds to: a) an aerial input level of 40 dB (pW) for FM radio tuners, i.e. 0,86 mV across 75 Ω or 1,73 mV across 300 Ω. The modulation factor is 54 %;			

- an aerial input e.m.f. of 1 mV for AM radio tuners. The modulation factor is 30 %;
- a vision carrier input level of 70 dB (μ V) for TV sound tuners, having the sound to vision carrier ratio of the relevant television system (see ITU-R BT.1700). The modulation factor is 54 % for both AM and FM.

The modulation factor of the above signals is based on the average modulation factor of the relevant emissions, averaged over at least 15 s;

- b) the output of a tape player or monitor, when reproducing a calibration tape in accordance with IEC 60094-2;
 - c) the output of a digital audio source (see footnote to table 9), when reproducing a sinewave signal recorded at a level 12 dB below "full scale" (see footnote to table d, item c) recorded digital signal;
 - d) a source level equal to the average level of the system in other cases.
- c) The value corresponds to:
- a) a level of 8 dB below the recording level given in footnote to table b, item b) above, in the case of a tape player or monitor;
 - b) the minimum source e.m.f. to the input of the system (8 dB below the rated source e.m.f.) in other cases.

The value as shown is not specified for tuners.

In the case of a digital audio source (see footnote to table 9), it is not necessary to define a minimum output voltage since it is directly related to the rated output voltage.

- d) The value corresponds to:
- a) the maximum r.f. input signal level and maximum modulation in the case of tuners. In some countries, FM emissions may exceed the rated maximum system deviation, while in others this is not permitted. AM emissions employing high-efficiency modulation techniques may produce at the receiver an audio output voltage corresponding to an apparent modulation of more than 100 %, up to approximately 150 %;
 - b) the maximum recording level in the case of a tape player or monitor;
 - c) the "full scale" level, which is the sinewave signal having positive and negative peak values represented by the digital values of 7FFFH and 8001H in a 16 bit system in the case of a digital audio source (see footnote to table 9). In the compact disc specification, these values correspond to a maximum (r.m.s.) analogue output voltage of $2 \text{ V} \pm 3 \text{ dB}$;
 - d) the input of the system when applying the overload source e.m.f. (12 dB above the rated source e.m.f.) in other cases.
- e) In the case of a tape recorder, the value which produces the same intensity of the magnetic field as that of the calibration tape in accordance with IEC 60094-2.
- f) For inputs intended only for the connection of analogue sources, the value is greater than or equal to 2,0 V. For inputs intended for the connection of analogue outputs of digital audio sources (see footnote to table 9), the value is greater than or equal to 2,8 V.
- g) The digital audio source may be a compact disc (CD) player, a digital audio tape (DAT/DCC) recorder or player, a television receiver with digital sound reception facilities or a receiver for digital audio broadcast (see footnote table h, below).
- h) For NICAM receivers, the relationship between the levels of alignment level tones transmitted by the broadcasting authorities and the maximum digital coding level, and between the levels of alignment level tones in mono and stereo modes, may vary in different countries. See:
- a) EBU Techn. SPB 424 (3rd Ed.)
 - b) NICAM 728: Specification for two additional digital sound channels with system I television, IBA, BREMA and BBC, London 1988.

8.2.2 Interfaces for professional equipment and consumer equipment where audio and video signals are present on the same connector or cable

Table 3 gives the values for audio signals for professional interfaces. This table does not apply to interfaces for broadcasting equipment. See Table 14.

Table 3 – General purpose values for audio signals for professional interfaces

Output ^a		Input	
	Recommended values		Recommended values
Output source impedance	≤1 kΩ	Rated source impedance	1 kΩ
Rated load impedance	10 kΩ ^g	Input impedance	≥10 kΩ
Rated output voltage	0,5 V ^b	Rated source e.m.f.	0,5 V ^e
Minimum output voltage	0,2 V ^c	Minimum source e.m.f. for rated output voltage	0,2 V
Maximum output voltage	2 V ^d	Overload source e.m.f.	≥2,8 V ^f

a The output voltages are measured with the rated load impedance connected.

b The value corresponds to:

- a) an aerial input level of 40 dB (pW) for FM radio tuners, i.e. 0,86 mV across 75 Ω or 1,73 mV across 300 Ω. The modulation factor is 54 %;
- an aerial input e.m.f. of 1 mV for AM radio tuners. The modulation factor is 30 %;
- a vision carrier input level of 70 dB (μV) for TV sound tuners, having the sound to vision carrier ratio of the relevant television system (see ITU-R BT.1700). The modulation factor is 54 % for both AM and FM.

The modulation factor of the above signals is based on the average modulation factor of the relevant emissions, averaged over at least 15 s;

- b) the output of a tape player or monitor, when reproducing a calibration tape in accordance with IEC 60094-2;
- c) the output of a digital audio source (see footnote to table ^h), when reproducing a sinewave signal recorded at a level 12 dB below "full scale" (see footnote to table ^d, item c) recorded digital signal;
- d) a source level equal to the average level of the system in other cases.

c The value corresponds to:

- a) a level of 8 dB below the recording level given in footnote to table ^b b) above, in the case of a tape player or monitor;
- b) the minimum source e.m.f. to the input of the system (8 dB below the rated source e.m.f.) in other cases.

The value as shown is not specified for tuners.

In the case of a digital audio source (see footnote to table ^h), it is not necessary to define a minimum output voltage since it is directly related to the rated output voltage.

d The value corresponds to:

- a) the maximum r.f. input signal level and maximum modulation in the case of tuners. In some countries, FM emissions may exceed the rated maximum system deviation, while in others this is not permitted. AM emissions employing high-efficiency modulation techniques may produce at the receiver an audio output voltage corresponding to an apparent modulation of more than 100 %, up to approximately 150 %;
- b) the maximum recording level in the case of a tape player or monitor;
- c) the "full scale" level, which is the sinewave signal having positive and negative peak values represented by the digital values of 7FFFH and 8001H in a 16 bit system in the case of a digital audio source (see footnote to table ^h). In the compact disc specification, these values correspond to a maximum (r.m.s.) analogue output voltage of 2 V ± 3 dB;
- d) the input of the system when applying the overload source e.m.f. (12 dB above the rated source e.m.f.) in other cases.

e In the case of a tape recorder, the value which produces the same intensity of the magnetic field as that of the calibration tape in accordance with IEC 60094-2.

f For inputs intended only for the connection of analogue sources, the value is greater than or equal to 2,0 V. For inputs intended for the connection of analogue outputs of digital audio sources (see footnote to table ^h), the value is greater than or equal to 2,8 V.

g	The rated load impedance should be 1 k Ω for professional applications.
h	The digital audio source may be a compact disc (CD) player, a digital audio tape (DAT/DCC) recorder or player, a television receiver with digital sound reception facilities or a receiver for digital audio broadcast (see footnote to table 1).
i	For NICAM receivers, the relationship between the levels of alignment level tones transmitted by the broadcasting authorities and the maximum digital coding level, and between the levels of alignment level tones in mono and stereo modes, may vary in different countries. See: <ul style="list-style-type: none"> a) EBU Techn. SPB 424 (3rd. Ed.) b) NICAM 728: Specification for two additional digital sound channels with system I television, IBA, BREMA and BBC, London 1988.

8.3 General purpose video input/output

Values for general purpose video input/output are given in Table 4 and in accompanying notes.

Table 4 – General purpose recommended values for video signals

Input/output	Recommended values		
	NTSC	PAL	SECAM
Rated impedance ^a	75 Ω		
Composite video signal ^b	1 V _{p-p} \pm 3 dB		
– Y" signal ^{b, e, f}	1 V _{p-p} \pm 3 dB		
– C" signal ^{c, f}	0,286 V _{p-p} \pm 3 dB	0,3 V _{p-p} \pm 3 dB	Not applicable
Primary colour (RGB) signal ^d : difference between peak value and blanking level	0,7 V \pm 0,1 V ^{d, f}		
Superimposed d.c. component	–	0 V to +2 V	
<p>^a The specified signal voltages should be measured under matched conditions.</p> <p>^b Difference between peak white level and synchronizing level. Synchronizing level should comply with ITU-R BT.1700. For the possible effects of non-standard synchronizing level, see IEC 60107-6.</p> <p>^c The values given in the table are the standard peak-to-peak amplitudes of the colour reference burst (for NTSC and PAL) and of the unmodulated dB chrominance carrier (for SECAM). The corresponding amplitude for PAL 100/0/100/0 colour bars is 885 mV, and for NTSC 100/7,5/100/7,5 colour bars the amplitude is 835 mV.</p> <p>^d For the analogue monochrome signals, the difference between any two primary colour signals and other parameters such as Y and vision colour signal shall not exceed 0,5 dB. The peak values of primary colour signals are those that give rise to a peak white luminance signal.</p> <p>^e The Y" signal consists of the composite signal according to ITU-R BT.1700 without the burst and chrominance signals or colour subcarrier.</p> <p>^f The permitted tolerances on the component signal levels should not be applied differentially. For example, a degraded picture quality is likely if the Y" signal level is at the minimum limit of tolerance and the C" signal at the maximum limit.</p>			

9 Interoperability of microphones and amplifiers

9.1 Microphones (excluding piezoelectric types)

Recommended values for microphones are given in Table 5.

Table 5 – Recommended values for microphones and amplifiers

Microphone	Amplifier	Recommended values		
		Electrodynamic microphones	Electrostatic microphones	
Output	Input for microphones		Professional use air- and electret-dielectric microphones	Consumer use electret microphones
Rated impedance	Rated source impedance	200 Ω	200 Ω	1 k Ω
Rated load impedance	–	1 k Ω	1 k Ω	5 k Ω
–	Input impedance ^a	≥ 1 k Ω	≥ 1 k Ω	>5 k Ω
Rated output voltage ^b	Rated source e.m.f.	0,2 mV	2 mV	2 mV
Maximum output voltage ^c	Overload source e.m.f. for broadcasting and sound reinforcement use ^c	0,2 V	5 V	not applicable
Maximum output voltage ^d	Overload source e.m.f. for household use ^d	20 mV	not applicable	200 mV

^a Impedance values apply over the frequency range 40 Hz to 16 kHz. Input impedance values should be as high as possible and consistent with the desired performance. Inputs of several devices can be connected in parallel when one microphone feeds different devices simultaneously, which may result in degraded microphone performance if the resulting load impedance is too low.

^b The values given relate to 0,2 Pa sound pressure (SPL = 80 dB (re 20 μ Pa) sound pressure level). The reference sensitivity values in this table are 1 mV/Pa for electrodynamic microphones and 10 mV/Pa for electrostatic microphones. Effective use of a microphone together with an amplifier depends on the minimum microphone output level being at least 5 dB higher than the inherent noise level of the amplifier, and the maximum microphone output level being no greater than the overload source e.m.f. of the amplifier. Attenuators or gain control circuits may be used in the microphone and the amplifier to achieve the desired dynamic range.

^c Values given relate to 100 Pa sound pressure (SPL = 134 dB (re 20 μ Pa) sound pressure level) taking into account a possible microphone sensitivity up to 50 mV/Pa for air and electret-dielectric microphones and up to 2 mV/Pa for dynamic microphones. The requirement for overload source e.m.f. may be met by means of an adjustable attenuator built into the amplifier.

^d Values given relate to 10 Pa sound pressure (SPL = 114 dB (re 20 μ Pa) sound pressure level) taking into account a possible 6 dB higher microphone sensitivity. For mains-operated household equipment the values given for broadcasting and sound reinforcement may be required, to avoid overload under extreme conditions.

9.2 Power supply feed for electret microphones fed over a signal conductor (“plug-in power”)

Power supply voltage $U = 1,5$ V to 5 V.

Feed resistor $R = 1$ k Ω to 10 k Ω .

Operating bias for unbalanced electret microphones is a positive d.c. voltage U fed through a resistor R to the signal conductor of the cable leading to the microphone. The signal is decoupled from the supply voltage using a series capacitor or other circuitry in the powering equipment. The negative pole of the supply voltage is connected to the signal return or screen. The precise values of U and R are not critical because current is limited by the characteristics of the field-effect transistor inside the electret microphone element.

NOTE This interface is described in JEITA CP-1203A:2007 with values of $U = 2,5$ V (+0,5 V, –1,0 V) and $R > 1$ k Ω .

Short-circuit current should be limited to 3 A.

The marking “PLUG IN POWER” should be visible adjacent to the powered input on the equipment.

Two-channel microphones using this interface are equipped with a three-conductor 3,5 mm concentric connector 60603-11-IEC-35P3, as shown in Figure 3. Single microphones using this interface are equipped with a two-conductor IEC 60603-11 connector, as shown in Figure 2.

Microphones using the IEC 60603-11 connector should be designed so that they are not damaged by being connected to equipment providing power on a separate conductor, such as that described in 9.3.

Single-channel powered inputs may also be wired as shown in Figure 3, with only one audio output used. This will permit most electret microphones designed to be fed by a separate conductor, as described in 9.3, also to function with such inputs.

9.3 Power supply feed for electret microphones fed by a separate conductor (“soundcard power” or “PC power”)

Power supply voltage $U = 2 \text{ V}$ to 5,5 V.

Operating current $I = 0,8 \text{ mA}$ maximum

Input impedance = 4 k Ω minimum

This requirement applies when use is made of the 60130-9 IEC 20/21 connector in accordance with IEC 60268-11:1987, Table III, as modified by Amendment 2:1991. The supply voltage is positive with respect to screen and return.

Desk-mounted, hand-held or head-worn electret microphones used in computer systems use 60603-11-IEC-35P3 (see IEC type designation in Clause 3 of IEC 60603-11:1992) 3,5 mm, 3-contact concentric connectors with $U = 5 \text{ V}$ and $R = 2,2 \text{ k}\Omega$, as shown in Figure 4. Such microphones should be designed so that they are not damaged by being connected with equipment designed for powering over the signal conductor as described in 9.2. $U = 5 \text{ V}$ is recommended for new designs, but microphones designed for this interface should function with $U = 2 \text{ V}$ to 5 V. Equipment should not be damaged by application of up to 10 V at the input connector.

Single-channel powered inputs may also be wired as shown in Figure 3, with only one audio output used. This will permit most electret microphones designed to be fed over a signal conductor, as described in 9.2, also to function with such inputs.

9.4 Phantom supply system

9.4.1 General

In the phantom supply system, both signal conductors have the same d.c. potential with respect to earth. This allows the use of microphone connections either for microphones which do not need a power supply (for example electrodynamic types), or for microphones having a circuit fed from a separate supply. In either case, it is essential that the amplifier to which the microphone is connected has a balanced floating input.

Equipment providing power to microphones using the phantom supply system may be a power supply, or powering circuitry incorporated in other equipment such as mixers and amplifiers. Typically a mixer or amplifier will include phantom powering on some or all of its inputs, which are referred to as “powered inputs.”

9.4.2 Supply voltage polarity

The positive pole of the supply voltage shall be connected to the electrical centre of the signal conductors, the negative pole to the earth or return conductor, which may be the screen of the cable.

9.4.3 Circuit diagram

A typical circuit diagram for connection and power supply is given in Figure 5. The resistors R_1 and R_2 shall be within 10 % of their rated value, and shall be matched to within no more than 0,4 %. Closer matching may be required to achieve the desired immunity from electromagnetic interference. The microphone should draw current symmetrically from the two conductors of the phantom powering system. The difference between the current in the two conductors should be less than 0,8 %.

Table 6 gives the required values for voltage and current and typical values for R_1 and R_2 . Instead of the resistors and/or transformers shown in the diagrams, other circuit components may be used, provided that the voltage and current requirements given in Table 6 are met, and that the balance of the circuit is not disturbed. A centre-tapped transformer fed via a series resistor may be used.

The use of values different from those of Table 6 may be preferred to fulfil the needs of special applications having wide dynamic range, or for power saving requirements. However, the connection of microphones designed for previously standardized phantom powering values may result in malfunction or even damage. Therefore, powered inputs using different values from those in Table 6 shall be adequately marked, and sufficient information in the specifications and operating manual shall be provided. A description of two alternate powering methods and recommendations for their use is given in Annex B.

9.4.4 Value of the supply voltage

Although 12 V and 24 V systems are still in use, P48 systems should be used for new developments.

9.4.5 Supply current

Microphones using the phantom supply system shall be designated to operate on one or more of the voltages shown in Table 6. When connected, a microphone shall consume no more than the maximum current listed. For best efficiency, microphones should be designed to consume no more than the rated current listed in Table 6, as this value results in the maximum amount of power being delivered to the microphone.

Equipment supplying power to microphones using the phantom supply system shall produce at least the rated current listed in Table 6, for each powered input to which a microphone can be connected. When microphones drawing the rated current are connected to all inputs of a device simultaneously, the voltage at any one input shall remain within the supply voltage limits when a microphone drawing the rated current is connected to or disconnected from any other input. When a microphone is connected or disconnected from a powering device, performance shall not be degraded for signals from other microphones powered by that device.

9.4.6 Marking

The supply voltage shall be marked on microphones and powering equipment using the designations from Table 6.

If a microphone is designed to operate on more than one supply voltage, this should be indicated by suitable marking, for example P48/12.

If a device supplying power using the phantom supply system is not capable of supplying the rated voltage and current to all powered inputs simultaneously, it shall be indicated by a suitable marking, for example "P48 maximum current xx mA."

Devices supplying power using values other than in Table 6 shall be marked with a suitable caution symbol and a designation as described in Annex B.

9.5 A-B supply system

9.5.1 General

In the A-B supply system, the supply current flows through the signal conductors a and b only (see Figure 6). Care should be taken to avoid incorrect operation by switching off the power supply before connecting microphones which do not need a d.c. power supply (for example dynamic types). If not built into the amplifier, suitable series capacitors shall be inserted in order to avoid d.c. magnetization of the input transformer.

9.5.2 Output impedance of the microphone

The output impedance of the microphone shall not exceed 200 Ω within the effective frequency range (40 Hz to 16 kHz).

9.5.3 Circuit diagram

The circuit diagram for connection and power supply is given in Figure 6. The resistors R_1 and R_2 shall be within 10 % of the rated value, but if the power supply is connected to earth (see 9.5.4), they shall be matched to within 1 %.

Table 7 gives the required values for voltage and current and typical values for R_1 and R_2 .

Instead of the resistors shown in the diagrams, other components may be used, provided they have the equivalent d.c. resistance.

9.5.4 Connection of the power supply to earth

The positive pole A or the negative pole B may be connected to earth.

9.5.5 Marking

Microphones for A-B supply shall be marked with the letters AB.

9.6 Polarity of the audio frequency voltage

An inward movement of the microphone diaphragm (a positive instantaneous sound pressure) shall produce a positive instantaneous voltage on pin 2 (with respect to pin 3) of the connector wired according to IEC 60268-12, or on pin 1 (with respect to pin 3) of the connector wired according to IEC 60268-11.

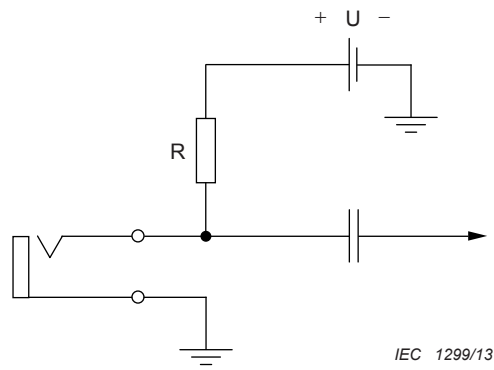

Figure 2 – Example of plug-in power system for a single microphone

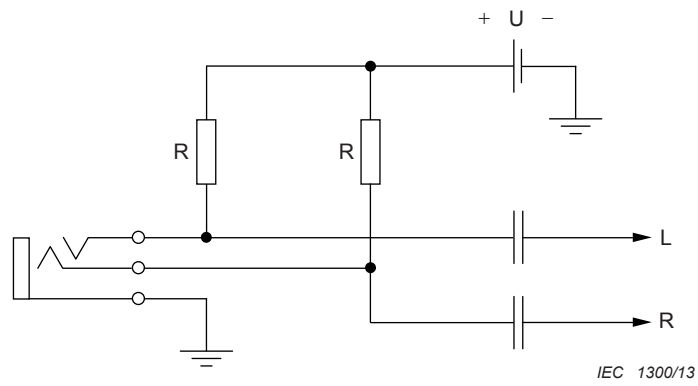

Figure 3 – Example of plug-in power system for a two-channel microphone

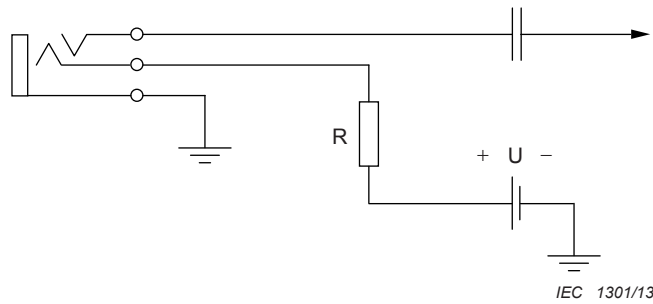
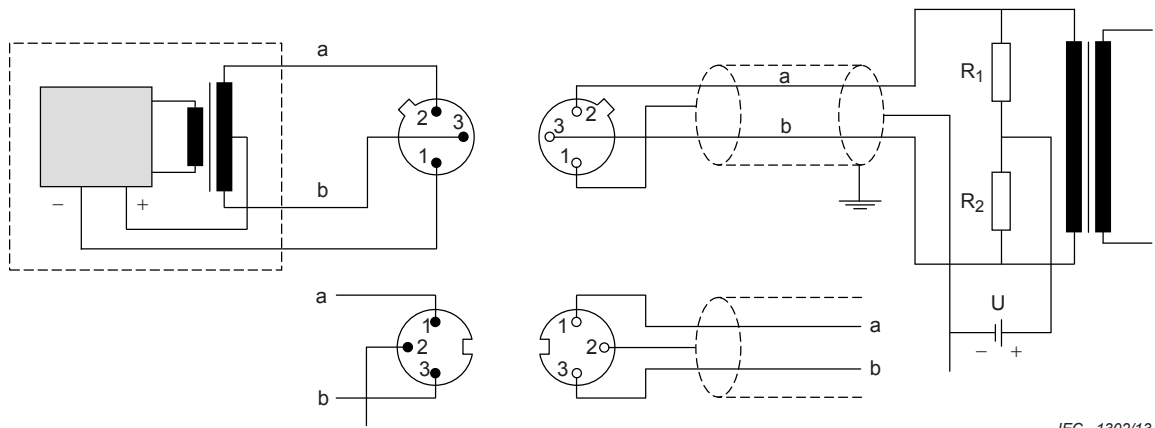
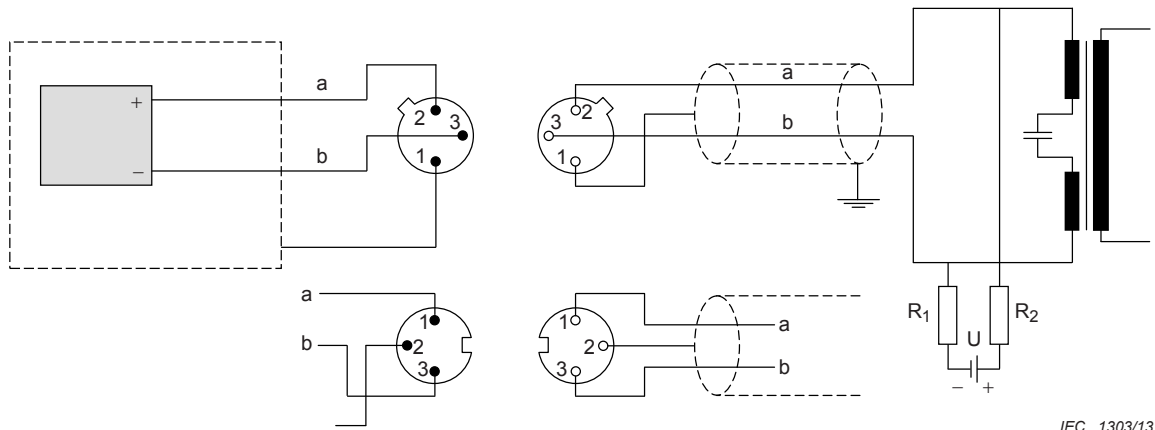

Figure 4 – Example of soundcard power system



IEC 1302/13

Figure 5 – Example of phantom power supply system



IEC 1303/13

Figure 6 – Example of A-B power supply system

Table 6 – Required values for phantom supply systems

Designation	P12	P24	P48
Supply voltage U	$12\text{ V} \pm 1\text{ V}$	$24\text{ V} \pm 4\text{ V}$	$48\text{ V} \pm 4\text{ V}$
Supply current I	Maximum 15 mA	Maximum 10 mA	Maximum 10 mA
Rated supply current	15 mA	10 mA	7 mA
R_1 and R_2 (typical values)	$680\ \Omega$	$1,2\text{ k}\Omega^a$	$6,8\text{ k}\Omega$

^a Equipment fitted with $1,2\text{ k}\Omega$ resistors is not compatible with some types of microphone designed for 12 V operation. These microphones require resistors of at least $2,4\text{ k}\Omega$ with a 24 V supply.

Table 7 – Required values for A-B power supply systems

Supply voltage U	$12\text{ V} \pm 1\text{ V}$
Supply current I	Maximum 15 mA
R_1 and R_2	$180\ \Omega$

10 Interoperability of record-playing units (pick-ups) and amplifiers

Recommended values for analogue record playing units and amplifiers are given in Table 8.

Table 8 – Recommended values for analogue record-playing units and amplifiers

Pick-up			Amplifier		
Output	Recommended values		Input for pick-up	Recommended values	
	Velocity sensitive			Velocity sensitive	
	High	Low		High	Low
Rated impedance	To be stated by the manufacturer		Rated source impedance	Series equivalent resistance: 2,2 kΩ The series equivalent inductance is also important	10 Ω
Rated load impedance	47 kΩ 420 pF ^c	100 Ω	Input impedance	47 kΩ in parallel with 220 pF	100 Ω
Rated output voltage ^a	5 mV	0,3 mV	Rated source e.m.f.	5 mV	0,3 mV
			Minimum source e.m.f. for rated output voltage	2,0 mV	0,12 mV
Maximum output voltage ^b	35 mV	2,8 mV	Overload source e.m.f.	≥35 mV	≥2,8 mV

^a The values are related to a velocity of 7 cm/s and the lower sensitivity limits footnote to table ^d below.

^b The values are related to a velocity of 17,5 cm/s and the upper sensitivity limits given in the remark above. The maximum output voltage values can be expected in the mid-frequency range between about 700 Hz and 3 000 Hz.

^c This value is based on a parallel capacitance of 200 pF for the record-playing unit and its connecting cable, and 220 pF input capacitance of the amplifier.

^d To determine the e.m.f. values given in the table, the following sensitivity ranges for pick-ups have been taken into account:

- high output: 0,7 mV/cm/s to 2 mV/cm/s;
- low output: 0,04 mV/cm/s to 0,16 mV/cm/s.

High output pick-ups are usually of the moving magnet type and low output pick-ups are usually of the moving coil type.

11 Interoperability of loudspeakers and amplifiers

11.1 Single unit loudspeakers

The following values of rated impedance for single unit loudspeakers should be: 4 Ω, 8 Ω and 16 Ω.

11.2 Loudspeaker systems

11.2.1 Loudspeakers with built-in amplifier

A loudspeaker system with a built-in amplifier shall be considered as a power amplifier. The values given in the right-hand part of Table 12 apply.

11.2.2 Impedance-defined loudspeaker systems

Recommended values for impedance defined loudspeaker systems are given in Table 9.

Table 9 – Recommended values for impedance-defined loudspeaker systems

Amplifier	Loudspeaker systems	Recommended values		
Output for loudspeakers	Input			
Output source impedance	–	<1/10 the rated load impedance over the rated frequency range		
Rated load impedance	Rated impedance	4 Ω	8 Ω	16 Ω

For electrostatic and piezoelectric loudspeakers, the rated impedance shall represent the impedance for correct interconnection, taking into consideration the capacitive character of the load presented to the amplifier.

11.2.3 Constant voltage loudspeaker systems

Recommended values for voltage defined loudspeaker systems are given in Table 10.

Table 10 – Recommended values for constant voltage loudspeaker systems

Amplifier	Loudspeaker systems	Recommended values				
Output for loudspeakers	Input					
Rated output voltage	–	25 V	35 V	50 V	70 V	100 V
–	Rated voltage	–	–	50 V	70 V	100 V
Output source impedance		<1/2 of the rated impedance over the rated frequency range				

The lower voltages in the table apply for the common practice of using a larger number of these loudspeakers at reduced power, each loudspeaker covering a smaller area.

NOTE The rated load impedance Z is calculated from the rated output power P of the amplifier and the line voltage V as given by $Z = V^2/P$.

The range of voltages may be extended to higher values for amplifiers designed for long distance distribution of power to a network of loudspeakers, for example, for line broadcasting in residential quarters from a central amplifying station.

11.3 Voltage (or power) interoperability of amplifiers and loudspeakers

11.3.1 Overview

In order to achieve optimum interoperability of amplifiers and loudspeakers, with regard to the intended conditions for use, the following characteristics are specified.

- Short-term maximum output voltage and power of an amplifier: see IEC 60268-3.
- Short-term maximum input voltage and power of a loudspeaker: see IEC 60268-5.
- Long-term maximum output voltage and power of an amplifier: see IEC 60268-3.
- Long-term maximum input voltage and power of a loudspeaker: see IEC 60268-5.

11.3.2 Interoperability requirements

The interoperability requirements depend on the condition of operation of the equipment as follows.

In the case of

- a) low probability of incorrect operation leading to clipping of the amplifier (e.g. most hi-fi applications), and where the short-term and the long-term output voltages or powers of the amplifier differ by more than 3 dB:
- the short-term input voltage or power of the loudspeaker shall be greater than or equal to the short-term output voltage or power of the amplifier;
 - the long-term input voltage of the loudspeaker shall be greater than or equal to one-half of the long-term output voltage of the amplifier;

NOTE This implies that the long-term input power of the loudspeaker is greater than one quarter of the long-term output power of the amplifier.

- b) low probability of incorrect operation leading to clipping of the amplifier (e.g. most hi-fi applications), and where the short-term and the long-term output voltages or powers of the amplifier are not substantially different (less than 3 dB):
- the long-term input voltage of the loudspeaker shall be greater than or equal to one-half of the long-term output voltage of the amplifier;

NOTE This implies that the long-term input power of the loudspeaker is greater than one quarter of the long-term output power of the amplifier.

- c) significant probability of clipping in the amplifier, (e.g. sound reinforcement and household use) but acoustic feedback or other types of oscillation are not taken into account:
- the long-term input voltage or power of the loudspeaker shall be greater than or equal to the long-term output voltage or power of the amplifier.

11.4 Polarity of the sound pressure

A positive instantaneous voltage at pin 1 with respect to pin 2 of the connector, according to IEC 60268-11, shall produce an outward movement of the loudspeaker diaphragm (a positive instantaneous sound pressure).

12 Interoperability of headphones and amplifiers

12.1 General

Headphones in stationary applications are mostly used for only a few hours per week, and with program material having a high dynamic range. In outside portable applications, mostly body-worn equipment is used, and it may be operated for several hours every day. The requirements for these two usage conditions differ so much that separate specifications are necessary, both for interoperability and with regard to hearing protection.

12.2 Interoperability of headphones with stationary amplifiers

This output is designed to produce, as far as possible, a constant sound pressure level in the headphones for a given setting of the volume control, irrespective of the impedance of the headphones over the range 8 Ω to 2 000 Ω . The recommended values are given in Table 11.

Electrostatic headphones equipped with matching units should also comply with the requirements of this clause. Other types of electrostatic headphones are not covered by this standard.

Table 11 – Recommended values for headphones and amplifiers in stationary applications

Amplifier		Headphones	
Output for headphones	Recommended values	Input from amplifier	Recommended values
Output source impedance ^a	120 Ω	Rated source impedance ^a	120 Ω
Rated load impedance	8 Ω to 2 000 Ω	Rated impedance	16, 32, 64, 200, 600 Ω
Rated source e.m.f.	5 V maximum ^{b, c}	Rated input voltage (see IEC 60268-7)	5 V
<p>^a For most types of headphones, the source impedance has very little effect on the performance.</p> <p>^b For equipment having a low supply voltage, it may not be possible to produce 5 V. If the rated output voltage is less than 5 V, the ability to operate with high impedance headphones is restricted.</p> <p>^c The 5 V (r.m.s.) represents a maximum signal voltage, on peaks of programme level. Signals at this voltage should not be clipped.</p> <p>^d The interface is also satisfactory for headphones with rated impedance between 8 Ω and 2 000 Ω.</p>			

12.3 Interoperability of portable audio headphones/earphones and portable audio equipment

12.3.1 General

This subclause specifies recommended values for portable audio headphones/earphones and portable audio equipment.

12.3.2 Portable audio headphones/earphones

Headphones/earphones which are intended to be used with battery operated audio equipment and to be mainly used for listening to music outdoors. The actual design is mostly of supra-aural type, intra-concha type, supra-concha type or insert type, however, also other solutions are in use. The main feature of all these headphones is their small size. Relevant characteristics of headphones are described in IEC 60268-7.

12.3.3 Portable audio equipment

The following pieces of equipment are included:

- portable, mostly body-worn players that operate with low DC energy sources;
- small audio equipment used with earphones, used mainly for listening to music outdoors; and
- DC operated players with separate AC adapters.

NOTE The call function of mobile-phones with music players is not included, however, the music player function is included.

12.3.4 Recommended values and input/output values for portable audio headphones/earphones and portable audio equipment

Portable audio pieces of equipment have a wide range of impedances. Long operating cycles require that any unnecessary power losses be avoided, e.g. by too high resistive source impedances. Very low source impedances lead to a constant signal voltage, but they also lead to a wider signal power variation than specified for stationary equipment. On the other hand, high resistive source impedances lead to a constant signal power, as specified for stationary equipment, but these source impedances lead to wider signal voltage.

To avoid dangerous sound levels it is important to evaluate the maximum sound pressure level, i.e. LA_{eqmax} , for every combination of portable audio headphones/earphones and portable audio equipment. Furthermore, it is preferable to let headphones be driven with a constant voltage when the maximum sound pressure level is defined in future.

In consideration of the above-mentioned issues, the recommended values are stated in Table 12.

Table 12 – Recommended values for portable audio headphones/earphones and portable audio equipment

Portable audio equipment		Portable audio headphones/earphones	
Output for headphones	Values	Input from amplifier	Values
Output source impedance	$\leq 120 \Omega^a$	Rated source impedance	$\leq 120 \Omega$
Rated load impedance	16 Ω to 64 Ω	Rated impedance	16, 32, 64 Ω^d
Rated source e.m.f.	Under consideration ^{b, c}	Rated input voltage	Under consideration ^e
<p>^a Portable audio equipment has a wide range of impedances. For output source impedances, a value of 2 Ω or less is recommended.</p> <p>^b The value to define safety limits is discussed in IEC TC 108 for the future edition of IEC 62368.</p> <p>^c The measurement procedure is given below:</p> <p>The measurement signal shall be a simulated programme signal in accordance with IEC 60268-1. This simulated programme signal shall have a crest factor ranging between 1,8 and 2,2. The value shall be defined as unweighted true r.m.s. voltage at the load resistance. As well as this value, the maximum output voltage V_{max} is defined as follows. All volume and tone controls of the players shall be adjusted to the maximum output voltage during tests. Player output shall be loaded with a resistive load of 16 Ω, 32 Ω and 64 Ω.</p> <p>^d The interface is also satisfactory for headphones with rated impedance between 16 Ω and 64 Ω.</p> <p>^e The value is same as the rated source e.m.f.</p> <p>For reference purposes:</p> <p>The maximum sound pressure level LA_{eqmax} can be calculated as follows:</p> $LA_{eqmax} = 94 + 20\lg(V_{max}/V_{emf})$ <p>where</p> <p>V_{max} is the maximum output voltage (see footnote to table ^c);</p> <p>V_{emf} is the simulated programme signal characteristic voltage corrected by A-weighting characteristics and free-field response compensation (see IEC 60268-7:2010, 8.3.5).</p>			

13 Interoperability of amplifiers with other amplifiers

13.1 Pre-amplifiers and power amplifiers for general purpose and sound reinforcement

Recommended values for pre-amplifiers and power amplifiers are given in Table 13.

Table 13 – Recommended values for pre-amplifiers and power amplifiers

Pre-amplifier		Power amplifier ^a	
Output	Recommended values	Input for pre-amplifier	Recommended values
Output source impedance	≤1 kΩ	Rated source impedance	1 kΩ
Rated load impedance	10 kΩ ^b	Input impedance	≥10 kΩ
Rated output voltage _c	1 V	–	–
–	–	Minimum source e.m.f. for rated output voltage	1 V
Rated distortion limited output voltage	≥3 V	–	–

^a For power amplifiers which have no volume controls, the rated source e.m.f. is identical to the minimum source e.m.f. for rated output voltage and the overload source e.m.f. does not apply.
Power amplifiers, however, may be provided with a volume control. In this case, the overload source e.m.f. should be ≥8 V.

^b The rated load impedance shall be 1 kΩ for pre-amplifiers for sound reinforcement. This permits up to 10 power amplifiers to be fed in parallel.

^c Applying the relevant minimum source e.m.f. for rated output voltage to the input of the pre-amplifier, with the gain control at maximum.

13.2 Broadcast and similar line amplifiers

Recommended values for broadcast and similar line amplifiers are given in Table 14.

Table 14 – Recommended values for broadcast and similar line amplifiers

Input	Recommended values	Output	Recommended values
Rated source impedance	0 Ω to 300 Ω	Output source impedance	0 Ω to 50 Ω between 10 Hz and 22,4 kHz
Input impedance	≥10 kΩ between 10 Hz and 22,4 kHz	Rated load impedance	600 Ω in parallel with 22 nF
Rated source e.m.f.	1,95 V +8 dB (0,775 V)	Normal working output voltage	1,95 V +8 dB (0,775 V)
Overload source e.m.f.	3,88 V +14 dB (0,775 V)	–	–
Unbalance	≤–50 dB (22,4 Hz to 10 kHz)	–	–

Inputs and outputs should be free of sharp peaks or dips in impedance between 10 Hz and 100 kHz in order to avoid undue sensitivity to electromagnetic interference. Care should be taken that all inputs are protected from radio frequency interference caused by shield-current induced noise, using e.g. the recommendations of AES48.

Annex A (informative)

Pairing and screening of conductors

Interconnections between equipment can create unwanted paths for magnetic and electromagnetic interference to enter conductive equipment enclosures causing degradation of performance, and unwanted paths for coupling of signals from one conductor to another. When it is necessary to reduce such interference, twisted pairs should be used for balanced signals, and for unbalanced signals carrying current of more than about 100 mA, such as loudspeaker wiring. Coaxial cable should be used for other unbalanced signals.

Twisted pairs and coaxial cables reduce the external fields generated by current flowing in the conductors, and by reciprocity reduce the sensitivity of these conductors to pick up such magnetic and electromagnetic fields.

The use of multi-pair cables, incorporating pairs twisted at different rates, is recommended for best immunity to crosstalk and interference.

Screening of paired conductors is of far less importance than twisting. When a paired conductor is provided with a screen, wire braid is preferred over metallic foil for reasons of ruggedness and balance, and to minimize the resistance of the screen.

Annex B (informative)

Phantom power variants for specialized applications

The requirements for most microphone applications can be met using one of the interface variants described in this standard. However, in some cases the amount of power provided to a microphone may be insufficient to permit the microphone to drive long cables without distortion. In other cases, equipment such as intercoms may be more efficiently made using lower current powered inputs. Standardized phantom power variants are listed in Table 6. Two variants have been defined as options to meet lower and higher requirements.

P12L is the designation for a specialized lower power interface intended for intercoms. Users of this variant should comply with the definitions of P12 and all other applicable parameters of this standard, except that supply current I is 8 mA maximum, rated supply current is 4 mA, and typical values for R_1 and R_2 are 3,3 k Ω . Interfaces using this variant should use a connector having 4 or more contacts to avoid inadvertent connection with incompatible equipment.

SP48 is the designation for a specialized interface intended for microphones that require more power than is provided by the normal P48 interface, to produce extended dynamic range, particularly when driving long cables. Users of this variant should comply with the definitions of P48 and all other applicable parameters of this standard, except that the supply current I and rated current are both 22 mA maximum, and typical values for R_1 and R_2 are 2,2 k Ω . Microphones using this variant should function when connected with P48 powering, but provide improved performance when connected with a powered input providing SP48 power. Technical data should include characteristics for P48 and SP48 operation.

Equipment with powered inputs using SP48 should also be switchable to provide P48 powering for use with microphones not rated for SP48. Most microphones designed for P48 will also function with SP48, but some models may malfunction or even be damaged. Suitable marking should be included near the powered input, such as “Use only with microphones rated for SP48” and the ISO 7000-0434B:2004, “Caution” symbol.



Suitable warnings should also be given in the manual, cautioning users of the equipment against use of SP48 with microphones not designed for the additional current.

Bibliography

IEC 60027 (all parts) *Letter symbols to be used in electrical technology*

IEC 60050-723:1997, *International Electrotechnical Vocabulary – Chapter 723: Broadcasting: Sound, television, data*

IEC 60417, *Graphical symbols for use on equipment*

IEC 60617, *Graphical symbols for diagrams*

IEC 60807-9:1993, *Rectangular connectors for frequencies below 3 MHz – Part 9: Detail specification for a range of peritelevision connectors*

IEC 61293:1994, *Marking of electrical equipment with ratings related to electrical supply – Safety requirements*

IEC 62368-1:2010, *Audio/video, information and communication technology equipment – Part 1: Safety requirements*

ISO/IEC 2382-9:1995, *Information technology – Vocabulary – Part 9: Data communication*

ISO 7000, *Graphical symbols for use on equipment*

AES48-2005:2010, *AES standard on interconnections – Grounding and EMC practices – Shields of connectors in audio equipment containing active circuitry*

JEITA CP-1203A:2007, *Preferred Matching Values of Analogue Signals for AV Equipment and Systems*

EBU1989. *Specification for transmission of two-channel digital sound with terrestrial television with television Systems B, G, and I, SPB424* (third revised version) EBU Technical Centre, Brussels

NICAM 728: *Specification for two additional digital sound channels with system I television*, IBA, BREMA and BBC, London 1988

see also:

A J Bower, 'NICAM 728 - *Digital two-channel sound for terrestrial television*' BBC Research Department Technical Report 1990/6. British Broadcasting Corporation, London, 1990.

Whitlock, Bill, *Balanced lines in audio systems, fact, fiction and transformers*, JAES, 43, 6, 1995-06 Audio Engineering Society, New York, NY USA.

British Standards Institution (BSI)

BSI is the national body responsible for preparing British Standards and other standards-related publications, information and services.

BSI is incorporated by Royal Charter. British Standards and other standardization products are published by BSI Standards Limited.

About us

We bring together business, industry, government, consumers, innovators and others to shape their combined experience and expertise into standards-based solutions.

The knowledge embodied in our standards has been carefully assembled in a dependable format and refined through our open consultation process. Organizations of all sizes and across all sectors choose standards to help them achieve their goals.

Information on standards

We can provide you with the knowledge that your organization needs to succeed. Find out more about British Standards by visiting our website at bsigroup.com/standards or contacting our Customer Services team or Knowledge Centre.

Buying standards

You can buy and download PDF versions of BSI publications, including British and adopted European and international standards, through our website at bsigroup.com/shop, where hard copies can also be purchased.

If you need international and foreign standards from other Standards Development Organizations, hard copies can be ordered from our Customer Services team.

Subscriptions

Our range of subscription services are designed to make using standards easier for you. For further information on our subscription products go to bsigroup.com/subscriptions.

With **British Standards Online (BSOL)** you'll have instant access to over 55,000 British and adopted European and international standards from your desktop. It's available 24/7 and is refreshed daily so you'll always be up to date.

You can keep in touch with standards developments and receive substantial discounts on the purchase price of standards, both in single copy and subscription format, by becoming a **BSI Subscribing Member**.

PLUS is an updating service exclusive to BSI Subscribing Members. You will automatically receive the latest hard copy of your standards when they're revised or replaced.

To find out more about becoming a BSI Subscribing Member and the benefits of membership, please visit bsigroup.com/shop.

With a **Multi-User Network Licence (MUNL)** you are able to host standards publications on your intranet. Licences can cover as few or as many users as you wish. With updates supplied as soon as they're available, you can be sure your documentation is current. For further information, email bsmusales@bsigroup.com.

BSI Group Headquarters

389 Chiswick High Road London W4 4AL UK

Revisions

Our British Standards and other publications are updated by amendment or revision.

We continually improve the quality of our products and services to benefit your business. If you find an inaccuracy or ambiguity within a British Standard or other BSI publication please inform the Knowledge Centre.

Copyright

All the data, software and documentation set out in all British Standards and other BSI publications are the property of and copyrighted by BSI, or some person or entity that owns copyright in the information used (such as the international standardization bodies) and has formally licensed such information to BSI for commercial publication and use. Except as permitted under the Copyright, Designs and Patents Act 1988 no extract may be reproduced, stored in a retrieval system or transmitted in any form or by any means – electronic, photocopying, recording or otherwise – without prior written permission from BSI. Details and advice can be obtained from the Copyright & Licensing Department.

Useful Contacts:

Customer Services

Tel: +44 845 086 9001

Email (orders): orders@bsigroup.com

Email (enquiries): cservices@bsigroup.com

Subscriptions

Tel: +44 845 086 9001

Email: subscriptions@bsigroup.com

Knowledge Centre

Tel: +44 20 8996 7004

Email: knowledgecentre@bsigroup.com

Copyright & Licensing

Tel: +44 20 8996 7070

Email: copyright@bsigroup.com



...making excellence a habit.™