

BS EN 61850-9-2:2011



BSI Standards Publication

Communication networks and systems for power utility automation

Part 9-2 Specific communication service
mapping (SCSM) — Sampled values over
ISO/IEC 8802-3

bsi.

...making excellence a habit.™

National foreword

This British Standard is the UK implementation of EN 61850-9-2:2011. It is identical to IEC 61850-9-2:2011. It supersedes BS EN 61850-9-2:2004 which is withdrawn.

The UK participation in its preparation was entrusted to Technical Committee PEL/57, Power systems management and associated information exchange.

A list of organizations represented on this committee can be obtained on request to its secretary.

This publication does not purport to include all the necessary provisions of a contract. Users are responsible for its correct application.

© The British Standards Institution 2012

Published by BSI Standards Limited 2012

ISBN 978 0 580 56433 8

ICS 33.200

Compliance with a British Standard cannot confer immunity from legal obligations.

This British Standard was published under the authority of the Standards Policy and Strategy Committee on 29 February 2012.

Amendments issued since publication

Amd. No.	Date	Text affected
----------	------	---------------

English version

**Communication networks and systems for power utility automation -
 Part 9-2: Specific communication service mapping (SCSM) -
 Sampled values over ISO/IEC 8802-3
 (IEC 61850-9-2:2011)**

Réseaux et systèmes de communication
 pour l'automatisation des systèmes
 électriques -
 Partie 9-2: Mise en correspondance des
 services de communication spécifiques
 (SCSM) -
 Valeurs échantillonnées
 sur l'ISO/CEI 8802-3
 (CEI 61850-9-2:2011)

Kommunikationsnetze und -systeme für
 die Automatisierung in der elektrischen
 Energieversorgung -
 Teil 9-2: Spezifische Abbildung von
 Kommunikationsdiensten (SCSM) -
 Abgetastete Werte über ISO/IEC 8802-3
 (IEC 61850-9-2:2011)

This European Standard was approved by CENELEC on 2011-10-27. CENELEC members are bound to comply with the CEN/CENELEC Internal Regulations which stipulate the conditions for giving this European Standard the status of a national standard without any alteration.

Up-to-date lists and bibliographical references concerning such national standards may be obtained on application to the CEN-CENELEC Management Centre or to any CENELEC member.

This European Standard exists in three official versions (English, French, German). A version in any other language made by translation under the responsibility of a CENELEC member into its own language and notified to the CEN-CENELEC Management Centre has the same status as the official versions.

CENELEC members are the national electrotechnical committees of Austria, Belgium, Bulgaria, Croatia, Cyprus, the Czech Republic, Denmark, Estonia, Finland, France, Germany, Greece, Hungary, Iceland, Ireland, Italy, Latvia, Lithuania, Luxembourg, Malta, the Netherlands, Norway, Poland, Portugal, Romania, Slovakia, Slovenia, Spain, Sweden, Switzerland and the United Kingdom.

CENELEC

European Committee for Electrotechnical Standardization
 Comité Européen de Normalisation Electrotechnique
 Europäisches Komitee für Elektrotechnische Normung

Management Centre: Avenue Marnix 17, B - 1000 Brussels

Foreword

The text of document 57/1133/FDIS, future edition 2 of IEC 61850-9-2, prepared by IEC/TC 57 "Power systems management and associated information exchange" was submitted to the IEC-CENELEC parallel vote and approved by CENELEC as EN 61850-9-2:2011.

The following dates are fixed:

- latest date by which the document has to be implemented at national level by publication of an identical national standard or by endorsement (dop) 2012-07-27
- latest date by which the national standards conflicting with the document have to be withdrawn (dow) 2014-10-27

This document supersedes EN 61850-9-2:2004.

EN 61850-9-2:2011 includes the following significant technical changes with respect to EN 61850-9-2:2004:

- addition of an optional Link redundancy layer (Tables 3 to 6);
- redefinition of "reserved" fields in link layer (5.3.3.4);
- evolution of USVCB and MSVCB components (Tables 9, 10, 12);
- evolution of encoding for the transmission of the sampled value buffer (Table 14).

Attention is drawn to the possibility that some of the elements of this document may be the subject of patent rights. CENELEC [and/or CEN] shall not be held responsible for identifying any or all such patent rights.

Endorsement notice

The text of the International Standard IEC 61850-9-2:2011 was approved by CENELEC as a European Standard without any modification.

Annex ZA (normative)

Normative references to international publications with their corresponding European publications

The following referenced documents are indispensable for the application of this document. For dated references, only the edition cited applies. For undated references, the latest edition of the referenced document (including any amendments) applies.

NOTE When an international publication has been modified by common modifications, indicated by (mod), the relevant EN/HD applies.

<u>Publication</u>	<u>Year</u>	<u>Title</u>	<u>EN/HD</u>	<u>Year</u>
IEC 60874-10-1	-	Connectors for optical fibres and cables - Part 10-1: Detail specification for fibre optic connector type BFOC/2,5 terminated to multimode fibre type A1	-	-
IEC 60874-10-2	-	Connectors for optical fibres and cables - Part 10-2: Detail specification for fibre optic connector type BFOC/2,5 terminated to single-mode fibre type B1	-	-
IEC 60874-10-3	-	Connectors for optical fibres and cables - Part 10-3: Detail specification for fibre optic adaptor type BFOC/2,5 for single and multimode fibre	-	-
IEC/TR 61850-1	-	Communication networks and systems in substations - Part 1: Introduction and overview	-	-
IEC/TS 61850-2	-	Communication networks and systems in substations - Part 2: Glossary	-	-
IEC 61850-6	-	Communication networks and systems for power utility automation - Part 6: Configuration description language for communication in electrical substations related to IEDs	EN 61850-6	-
IEC 61850-7-1	-	Communication networks and systems for power utility automation - Part 7-1: Basic communication structure - Principles and models	EN 61850-7-1	-
IEC 61850-7-2	-	Communication networks and systems for power utility automation - Part 7-2: Basic information and communication structure - Abstract communication service interface (ACSI)	EN 61850-7-2	-
IEC 61850-7-3	-	Communication networks and systems for power utility automation - Part 7-3: Basic communication structure - Common data classes	EN 61850-7-3	-
IEC 61850-7-4	-	Communication networks and systems for power utility automation - Part 7-4: Basic communication structure - Compatible logical node classes and data object classes	EN 61850-7-4	-

<u>Publication</u>	<u>Year</u>	<u>Title</u>	<u>EN/HD</u>	<u>Year</u>
IEC 61850-8-1	-	Communication networks and systems for power utility automation - Part 8-1: Specific Communication Service Mapping (SCSM) - Mappings to MMS (ISO 9506-1 and ISO 9506-2) and to ISO/IEC 8802-3	EN 61850-8-1	-
IEC/TS 62351-6	-	Power systems management and associated information exchange - Data and communications security - Part 6: Security for IEC 61850	-	-
IEC 62439-3 + A1	2010 201X ¹⁾	Industrial communication networks - High availability automation networks - Part 3: Parallel Redundancy Protocol (PRP) and High availability Seamless Redundancy (HSR)	EN 62439-3 + A1	2010 201X ¹⁾
ISO/IEC 7498-1	1994	Information technology - Open Systems Interconnection - Basic Reference Model: The Basic Model	-	-
ISO/IEC 8326	1996	Information technology - Open systems Interconnection - Session service definition	-	-
ISO/IEC 8327-1	1996	Information technology - Open Systems Interconnection - Connection-oriented Session protocol: Protocol specification	-	-
ISO/IEC 8649	1996	Information technology - Open systems interconnection - Service definition for the Association Control Service Element (ACSE)	-	-
ISO/IEC 8650-1	1996	Information technology - Open systems interconnection - Connection-oriented protocol for the association control service element: Protocol specification	-	-
ISO/IEC 8802-3	2000	Information technology - Telecommunications and information exchange between systems - Local and metropolitan area networks - Specific requirements - Part 3: Carrier sense multiple access with collision detection (CSMA/CD) access method and physical layer specifications	-	-
ISO/IEC 8822	1994	Information technology - Open Systems Interconnection - Presentation service definition	-	-
ISO/IEC 8823-1	1994	Information technology - Open Systems Interconnection - Connection-oriented presentation protocol: Protocol specification	-	-
ISO/IEC 8824-1	2008	Information technology - Abstract Syntax Notation One (ASN.1): Specification of basic notation	-	-
ISO/IEC 8825-1	-	Information technology - ASN.1 encoding rules: Specification of Basic Encoding Rules (BER), Canonical Encoding Rules (CER) and Distinguished Encoding Rules (DER)	-	-

¹⁾ To be published.

<u>Publication</u>	<u>Year</u>	<u>Title</u>	<u>EN/HD</u>	<u>Year</u>
ISO 9506-1	2003	Industrial automation systems - Manufacturing - Message Specification - Part 1: Service definition	-	-
ISO 9506-2	2003	Industrial automation systems - Manufacturing Message Specification - Part 2: Protocol specification	-	-
IEEE 754	1985	Binary Floating-Point Arithmetic (R1990)	-	-
IEEE 802.1Q	1998	IEEE Standard for Local and Metropolitan Area Networks: Virtual Bridged Local Area Networks	-	-
IETF RFC 791	-	Internet Protocol - DARPA Internet Program Protocol Specification	-	-
IETF RFC 792	-	Internet Control Message Protocol	-	-
IETF RFC 793	-	Transmission Control Protocol - DARPA Internet Program Protocol Specification	-	-
IETF RFC 826	-	Ethernet Address Resolution Protocol	-	-
IETF RFC 894	-	Standard for the Transmission of IP Datagrams over Ethernet Networks	-	-
IETF RFC 919	-	Broadcasting Internet Datagrams	-	-
IETF RFC 1006	-	ISO transport services on top of TCP: Version 3	-	-
IETF RFC 1112	-	Host Extensions for IP Multicasting	-	-

CONTENTS

INTRODUCTION	6
1 Scope	7
2 Normative references	7
3 Terms and definitions	9
4 Abbreviations	9
5 Communication stack	10
5.1 Overview of the protocol usage	10
5.2 Client/server services and communication profiles	11
5.2.1 Client/server services	11
5.2.2 A-Profile	12
5.2.3 TCP/IP T-Profile	13
5.3 SV service and communication profile	13
5.3.1 SV mapping overview	13
5.3.2 A-Profile	14
5.3.3 T-Profile	14
5.4 Restrictions	17
6 Mapping of IEC 61850-7-2 and IEC 61850-7-3 data attributes	17
7 Mapping of IEC 61850-7-2 classes and services	17
7.1 Classes of SV data sets	17
7.2 Definition of SV data sets	17
8 Mapping of the model for the transmission of sampled values	18
8.1 Overview	18
8.2 Mapping of the multicast sampled value control block class and services	18
8.2.1 Multicast sampled value control block definition	18
8.2.2 MSV Services	19
8.3 Mapping of the unicast sampled value control block class and services	20
8.3.1 Unicast sampled value control block definition	20
8.3.2 USV Services	21
8.4 Mapping of the update of the sampled value buffer	21
8.5 Additional definitions for the transmission of sampled values	21
8.5.1 Application layer functionality	21
8.5.2 Presentation layer functionality	22
8.6 Definitions for basic data types – Presentation layer functionality	24
9 Conformance	24
9.1 Notation	24
9.2 PICS	24
9.2.1 Profile conformance	24
9.2.2 SV Services	25
10 Substation configuration language (SCL)	25
11 SCSM specific address element definitions	26
Annex A (informative) ISO/IEC 8802-3 frame format and ASN.1 basic encoding rules	27
Annex B (informative) Multicast address selection	32

Figure 1 – OSI reference model and profiles.....	11
Figure 2 – Structure of the tag header	15
Figure 3 – Reserved 1	16
Figure 4 – Concatenation of several ASDU's into one frame	22
Figure A.1 – ISO/IEC 8802-3 frame format – No link redundancy	27
Figure A.2 – ISO/IEC 8802-3 frame format – Link redundancy: HSR	28
Figure A.3 – ISO/IEC 8802-3 frame format – Link redundancy: PRP	29
Figure A.4 – Basic encoding rules format	30
Figure A.5 – Format of the tag octets	30
Figure A.6 – Example for an ASN.1 coded APDU frame structure	31
Table 1 – Service requiring client/server communication profile	12
Table 2 – Service and protocols for client/server communication A-Profile	12
Table 3 – Service and protocols for peer TCP/IP T-Profile	13
Table 4 – Service requiring SV communication profile	13
Table 5 – Service and protocols for SV communication A-Profile	14
Table 6 – SV T-Profile	14
Table 7 – Default Virtual LAN IDs and priorities.....	15
Table 8 – Assigned Ethertype values	16
Table 9 – MMS TypeDescription definition for MSVCB MMS structure.....	18
Table 10 – DstAddress structure	19
Table 11 – Mapping of multicast sampled value services	19
Table 12 – MMS TypeDescription definition for USVCB MMS structure	20
Table 13 – Mapping of unicast sampled value services	21
Table 14 – Encoding for the transmission of the sampled value buffer	22
Table 15 – Encoding for the basic data types.....	24
Table 16 – PICS for A-Profile support.....	25
Table 17 – PICS for T-Profile support.....	25
Table 18 – SV conformance statement.....	25
Table 19 – Definitions for SV SCL.....	26
Table B.1 – Recommended multicast addressing example.....	32

INTRODUCTION

This part of IEC 61850 defines the SCSM for sampled values over ISO/IEC 8802-3. The intent of this SCSM definition is to include the complete mapping of the sampled value model.

This part of IEC 61850 applies to electronic current and voltage transformers (ECT and EVT having a digital output), merging units, and intelligent electronic devices, for example protection units, bay controllers and meters, or sensors.

Process bus communication structures can be arranged in different ways as described in IEC/TR 61850-1. In addition to the transmission of sampled value data sets, which are directly connected to ISO/IEC 8802-3, a selection of IEC 61850-8-1 services is necessary to support the access to the SV control block. References to the relevant IEC 61850-8-1 services are provided in this SCSM. For less complex devices (for example merging units), the sampled value control block can be pre-configured, in which case there is no need to implement IEC 61850-8-1 services based on the MMS-Stack.

This document defines the mapping of sampled value class model (IEC 61850-7-2) to ISO/IEC 8802-3. This SCSM, in combination with IEC 61850-7 and IEC 61850-6, allows interoperability between devices from different manufacturers.

This standard does not specify individual implementations or products, nor does it constrain the implementation of entities and interfaces within a computer system. This standard specifies the externally visible functionality of implementations together with conformance requirements for such functionalities.

Reading guide:

- This document is an extended mapping specification of IEC 61850-8-1 to cover sampled value transmission over ISO/IEC 8802-3.
- This document can best be understood if the reader is thoroughly familiar with IEC 61850-7-1, IEC 61850-7-2, IEC 61850-7-3 and IEC 61850-7-4.
- The ACSI services defined in IEC 61850-7-2 are not explained in this part of IEC 61850.

COMMUNICATION NETWORKS AND SYSTEMS FOR POWER UTILITY AUTOMATION –

Part 9-2: Specific communication service mapping (SCSM) – Sampled values over ISO/IEC 8802-3

1 Scope

This part of IEC 61850 defines the specific communication service mapping (SCSM) for the transmission of sampled values according to the abstract specification in IEC 61850-7-2. The mapping is that of the abstract model on a mixed stack using direct access to an ISO/IEC 8802-3 link for the transmission of the samples in combination with IEC 61850-8-1.

Each SCSM consists of three parts:

- a specification of the communication stack being used,
- the mapping of the abstract specifications of IEC 61850-7 series on the real elements of the stack being used, and
- the implementation specification of functionality, which is not covered by the stack being used.

2 Normative references

The following referenced documents are indispensable for the application of this document. For dated references, only the edition cited applies. For undated references, the latest edition of the referenced document (including any amendments) applies.

IEC 60874-10-1, *Connectors for optical fibres and cables – Part 10-1: Detail specification for fibre optic connector type BFOC/2,5 terminated to multimode fibre type A1* (withdrawn)

IEC 60874-10-2, *Connectors for optical fibres and cables – Part 10-2: Detail specification for fibre optic connector type BFOC/2,5 terminated to single-mode fibre type B1* (withdrawn)

IEC 60874-10-3, *Connectors for optical fibres and cables – Part 10-3: Detail specification for fibre optic adaptor type BFOC/2,5 for single and multimode fibre* (withdrawn)

IEC/TR 61850-1, *Communication networks and systems for power utility automation – Part 1: Introduction and overview*

IEC/TS 61850-2, *Communication networks and systems for power utility automation – Part 2: Glossary*

IEC 61850-6, *Communication networks and systems for power utility automation – Part 6: Configuration description language for communication in electrical substations related to IEDs*

IEC 61850-7-1, *Communication networks and systems for power utility automation – Part 7-1: Basic communication structure – Part 7-1: Principles and models*

IEC 61850-7-2, *Communication networks and systems for power utility automation – Part 7-2: Basic information and communication structure – Abstract communication service interface (ACSI)*

IEC 61850-7-3, *Communication networks and systems for power utility automation – Part 7-3: Basic communication structure – Common data classes*

IEC 61850-7-4, *Communication networks and systems for power utility automation – Part 7-4: Basic communication structure – Compatible logical node classes and data object classes*

IEC 61850-8-1, *Communication networks and systems for power utility automation – Part 8-1: Specific Communication Service Mapping (SCSM) – Mappings to MMS (ISO 9506-1 and ISO 9506-2) and to ISO/IEC 8802-3*

IEC/TS 62351-6, *Power systems management and associated information exchange – Data and communications security – Part 6: Security for IEC 61850*

IEC 62439-3:2010, *Industrial communication networks – High availability automation networks – Part 3: Parallel Redundancy Protocol (PRP) and High-availability Seamless Redundancy (HSR) Amendment 1¹*

ISO/IEC 7498-1:1994, *Information technology – Open Systems Interconnection – Basic Reference Model: The Basic Model*

ISO/IEC 8326:1996, *Information technology – Open Systems Interconnection – Session service definition*

ISO/IEC 8327-1:1996, *Information technology – Open Systems Interconnection – Connection-oriented session protocols: Protocol specification*

ISO/IEC 8649:1996, *Information technology – Open Systems Interconnection – Service definition for the Associated Control Service Element*

ISO/IEC 8650-1:1996, *Information technology – Open Systems Interconnection – Connection-oriented protocol for the Association Control Service Element: Protocol specification*

ISO/IEC 8802-3:2000, *Information technology – Telecommunications and information exchange between systems – Local and metropolitan area networks – Specific requirements – Part 3: Carrier sense multiple access with collision detection (CSMA/CD) access method and physical layer specifications*

ISO/IEC 8822:1994, *Information technology – Open Systems Interconnection – Presentation service definition*

ISO/IEC 8823-1:1994, *Information technology – Open Systems Interconnection – Connection-oriented presentation protocol: Protocol specification*

ISO/IEC 8824-1:2008, *Information technology – Abstract Syntax Notation One (ASN. 1): Specification of basic notation*

ISO/IEC 8825-1, *Information technology – ASN.1 encoding rules: Specification of Basic Encoding Rules (BER), Canonical Encoding Rules (CER) and Distinguished Encoding Rules (DER)*

ISO 9506-1:2003, *Industrial automation systems – Manufacturing Message Specification – Part 1: Service definition*

¹ To be published.

ISO 9506-2:2003, *Industrial automation systems – Manufacturing Message Specification – Part 2: Protocol specification*

IEEE 754:1985, *IEEE Standard for Binary Floating-Point Arithmetic*

IEEE 802.1Q:1998, *IEEE Standards for Local and Metropolitan Area Networks: Virtual Bridged Local Area Networks*

RFC 791, *Internet Protocol*; IETF, available at <http://www.ietf.org> [cited on 2011-03-18]

RFC 792, *Internet Control Message Protocol*; IETF, available at <http://www.ietf.org> [cited on 2011-03-18]

RFC 793, *Transmission Control Procedure*; IETF, available at <http://www.ietf.org> [cited on 2011-03-18]

RFC 826, *Ethernet Address Resolution Protocol or Converting Network Protocol Addresses to 48.bit Ethernet Address for Transmission on Ethernet Hardware*; IETF, available at <http://www.ietf.org> [cited on 2011-03-18]

RFC 894, *A Standard for the Transmission of IP Datagrams over Ethernet Networks*; IETF, available at <http://www.ietf.org> [cited on 2011-03-18]

RFC 919, *Broadcasting Internet Datagrams*; IETF, available at <http://www.ietf.org> [cited on 2011-03-18]

RFC 1006 *ISO transport services on top of TCP: Version 3*; IETF, available at <http://www.ietf.org> [cited on 2011-03-18]

RFC 1112, *Host Extensions for IP multicasting*; IETF, available at <http://www.ietf.org> [cited on 2011-03-18]

3 Terms and definitions

For the purposes of this document, the terms and definitions given in IEC/TS 61850-2 apply.

4 Abbreviations

ACSI	Abstract communication service interface
ASDU	Application service data unit
ASN.1	Abstract syntax notation number one
APCI	Application protocol control information
APDU	Application protocol data unit
APPID	Application identifier
AUI	Attachment unit interface
BER	ASN.1 basic encoding rules
BS	Bitstring
c	Conditional support. The item shall be implemented if the stated condition exists
CFI	Canonical format identifier

CSMA/CD	Carrier sense multiple access/collision detection
DF	Data frame
DO	Data object
ECT	Electronic current transformer
EVT	Electronic voltage transformer
F/S	Functional standard
GOOSE	Generic object oriented substation event
GSSE	Generic substation status event
i	Out-of-scope: The implementation of the item is not within the scope of this standard
ICD	IED configuration description
IED	Intelligent electronic device
LSDU	Link layer service data unit
m	Mandatory support. The item shall be implemented
MAC	Media access control
MAU	Medium attachment unit
MMS	Manufacturing message specification (ISO 9506)
MSVCB	Multicast sampled value control block
MU	Merging unit
o	Optional support. The implementor may decide to implement the item
PDU	Protocol data unit
PICS	Protocol implementation conformance statement
SCSM	Specific communication services mapping
r	readable
SV	Sampled value
TCI	Tag control information
TPID	Tag protocol identifier
USVCB	Unicast sampled value control block
VID	VLAN identifier
VLAN	Virtual local area network
VMD	Virtual manufacturing device
w	Writeable
x	Excluded: The implementor shall not implement this item
XML	Extensible markup language

5 Communication stack

5.1 Overview of the protocol usage

The OSI reference model (ISO/IEC 7498-1) defines a model based upon the concept of layering of communication functions. The model includes 7 layers and specifies the functional requirements for each layer to achieve a robust communication system. The model does not

specify the protocols to be used to achieve the functionality, nor does it restrict the solution to a single set of protocols.

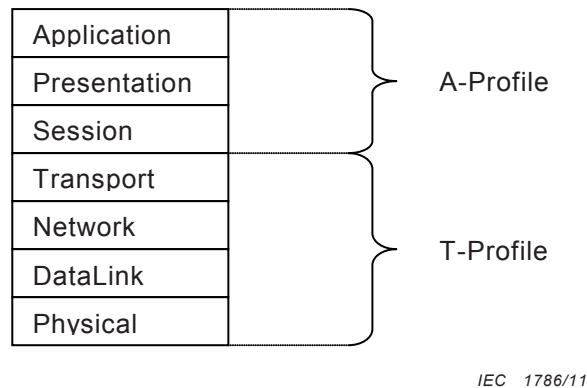

Figure 1 – OSI reference model and profiles

The use of ISO application (A-Profile) and transport (T-Profile) profiles (see Figure 1) describes the various stack profiles. An ISO A-Profile is the set of specifications and agreements relating to the upper three (3) layers of the ISO OSI reference model (for example the application, presentation, and session layers). An ISO T-Profile is the set of specifications and agreements relating to the lower four (4) layers of the ISO OSI reference model (for example the transport, network, datalink and physical layers).

Two combinations of A-Profiles and T-Profiles are defined in order to support the transmission of sampled values including the access to the associated SV control block, as specified in IEC 61850-7-2. The two different combinations are used for:

- client/server services based on MMS in accordance to IEC 61850-8-1;
- SV services based on datalink layer.

5.2 Client/server services and communication profiles

5.2.1 Client/server services

This client/server communication profile shall be used in addition to the SV communication profile according to 5.3 if an access to the sampled value control block via client is required. This profile shall be used for any implementation claiming conformance to this standard and declaring support for one of the following IEC 61850-7-2 services in Table 1.

Table 1 – Service requiring client/server communication profile

IEC 61850-7-2 model	IEC 61850-7-2 service
Server	GetServerDirectory
Association	Associate
	Abort
	Release
Logical device	GetLogicalDeviceDirectory
Logical node	GetLogicalNodeDirectory
	GetAllDataValues
Data	GetDataValues
	SetDataValues
	GetDataDirectory
	GetDataDefinition
Data set	GetDataSetValues
	SetDataSetValues
	CreateDataSet
	DeleteDataSet
	GetDataSetDirectory
SV class model	GetMSVCBValues
	SetMSVCBValues
	GetUSVCBValues
	SetUSVCBValues

5.2.2 A-Profile

Table 2 shows services and protocols of the A-Profile client/server.

Table 2 – Service and protocols for client/server communication A-Profile

OSI model layer	Specification			m/o
	Name	Service specification	Protocol specification	
Application	Manufacturing message specification	ISO 9506-1:2000	ISO 9506-2:2000	m
	Association control service element	ISO/IEC 8649:1996	ISO/IEC 8650-1:1996	m
Presentation	Connection oriented presentation	ISO/IEC 8822:1994	ISO/IEC 8823-1:1994	m
	Abstract syntax	ISO/IEC 8824-1:2008	ISO/IEC 8825-1	m
Session	Connection oriented session	ISO/IEC 8326:1996	ISO/IEC 8327-1:1996	m

There is only one T-Profile (TCP/IP) that may be used by the client/server A-Profile.

5.2.3 TCP/IP T-Profile

Table 3 shows services and protocols of the TCP/IP T-Profile client/server.

Table 3 – Service and protocols for peer TCP/IP T-Profile

OSI model layer	Specification			m/o
	Name	Service specification	Protocol specification	
Transport	ISO transport on top of TCP	RFC 1006		m
	Internet control message protocol (ICMP)	RFC 792		m
	Transmission control protocol (TCP)	RFC 793		m
Network	Internet protocol	RFC 791		
	Converting network protocol address	RFC 826 (Address resolution protocol: ARP)		m
	Broadcasting internet datagrams	RFC 919		m
	Host extensions for IP multicasting	RFC 1112		m
Link Redundancy	Parallel redundancy protocol and high availability seamless ring	IEC 62439-3, Amendment 1		o
DataLink	Standard for the transmission of IP datagrams over Ethernet networks	RFC 894		m
	Carrier sense multiple access with collision detection (CSMA/CD)	ISO/IEC 8802-3:2000		m
Physical	Fibre optic transmission system 100Base-FX	ISO/IEC 8802-3:2000		c1
	Basic optical fibre connector NOTE This is the specification for the ST connector.	IEC 60874-10-1, IEC 60874-10-2 and IEC 60874-10-3		c1
c1 – Recommended, but future technology could be used.				

5.3 SV service and communication profile

5.3.1 SV mapping overview

This SV communication profile shall be used for any implementation claiming conformance to this standard and declaring support for one of the following IEC 61850-7-2 services in Table 4.

Table 4 – Service requiring SV communication profile

Model	IEC 61850-7-2 service
Multicast sampled value class model	Multicast SV message
Unicast sampled value class model	Unicast SV message

5.3.2 A-Profile

Table 5 shows services and protocols of the A-Profile SV.

Table 5 – Service and protocols for SV communication A-Profile

OSI model layer	Specification			m/o
	Name	Service specification	Protocol specification	
Application	SV service			m
Presentation	Abstract syntax	ISO/IEC 8824-1:2008	ISO/IEC 8825-1	m
Session				

Presentation layer: see additional definitions in 8.5.

Application layer: see additional definitions in 8.5.

5.3.3 T-Profile

The T-Profile for SV services is shown in Table 6.

Table 6 – SV T-Profile

OSI model layer	Specification			m/o
	Name	Service specification	Protocol specification	
Transport				
Network				
Link Redundancy	Parallel redundancy protocol and high availability seamless ring	IEC 62439-3, Amendment 1		o
DataLink	Priority tagging/VLAN	IEEE 802.1Q		m
	Carrier sense multiple access with collision detection (CSMA/CD)	ISO/IEC 8802-3:2000		m
Physical	Fibre optic transmission system 100Base-FX	ISO/IEC 8802-3:2000		c1
	Basic optical fibre connector NOTE This is the specification for the ST connector.	IEC 60874-10-1, IEC 60874-10-2 and IEC 60874-10-3		c1

c1 – Recommended, but future technology could be used.

5.3.3.1 Physical layer: Specifications for the medium attachment unit (MAU)

The optical fibre transmission system 100Base-FX according to ISO/IEC 8802-3 is recommended as indicated above because of requirements relating to the electromagnetic environment.

5.3.3.2 Link layer: Ethernet addresses

The destination ISO/IEC 8802-3 multicast/unicast address has to be configured for the transmission of sampled values. A unique ISO/IEC 8802-3 source address shall be used. Recommendations of multicast address range assignments are given in Annex B.

5.3.3.3 Link layer: Priority tagging/virtual LAN

Priority tagging according to IEEE 802.1Q is used to separate time critical and high priority bus traffic for protection-relevant applications from low priority busload.

See Figure 2 for the structure of the tag header.

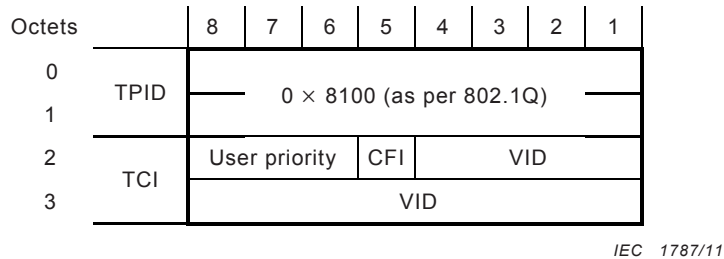

Figure 2 – Structure of the tag header

TPID (tag protocol identifier) field: Indicates the Ethernet type assigned for 802.1Q Ethernet encoded frames. This value shall be 0x8100.

TCI (tag control information) fields: User priority: BS3; User priority value shall be set by configuration to separate sampled values from low priority busload. If the priority is not configured, then the default values of Table 7 shall be used.

CFI (canonical format indicator): BS1 [0]; A single bit flag value. For this standard, the CFI bit value shall be reset (value = 0).

NOTE 1 If set (value = 1), an embedded resource identification field (E-RIF) follows the Length/Type field in the ISO/IEC 8802-3 tagged frame.

VID: Virtual LAN support is optional. If this mechanism will be used, the VLAN identifier (VID) shall be set by configuration, if it is not used, it shall be set to zero (0).

NOTE 2 As IEEE 802.1Q allows implementation with a restricted set of priorities, the higher priority frames should have a priority of 4 to 7 and the lower priority should have a priority of 1 to 3. The value 1 is the priority of untagged frames thus 0 should be avoided as it may cause unpredictable delay due to normal traffic.

Additionally, since sampled values need to have potentially its own bandwidth allocation, their configured VID will be different from GOOSE and GSSE.

The default values for priority and VID shall be as defined in Table 7.

Table 7 – Default Virtual LAN IDs and priorities

Service	Default VID	Default priority
Sampled Values	0	4

The general ISO/IEC 8802-3 frame structure for sampled values can be found in Annex A.

5.3.3.4 Link layer: Ethertype and other header information

5.3.3.4.1 Ethertype

Ethertypes based on ISO/IEC 8802-3 MAC-sublayer are registered by the IEEE authority registration. GSE management, GOOSE and samples values shall be directly mapped to the reserved Ethertype(s) and the Ethertype PDU. The assigned values are found in Table 8.

Table 8 – Assigned Ethertype values

Use	Ethertype value (hexadecimal)	APPID type
IEC 61850-8-1 GOOSE	88-B8	0 0
IEC 61850-8-1 GSE Management	88-B9	0 0
IEC 61850-9-2 Sampled Values	88-BA	0 1

The Ethertype PDU and APDU octets shall be as defined in Annex A.

5.3.3.4.2 APPID

Application identifier. The APPID is used to select ISO/IEC 8802-3 frames containing sampled value messages and to distinguish the application association.

The value of APPID is the combination of the APPID type, defined as the two most significant bits of the value (as defined in Table 8), and the actual ID.

The reserved value range for sampled values is 0x4000 to 0x7FFF. If no APPID is configured, the default value shall be 0x4000. The default value is reserved to indicate lack of configuration. It is strongly recommended to have unique, source orientated SV APPID within a system, in order to enable a filter on link layer. The configuration of APPID should be enforced by the configuration system.

5.3.3.4.3 Length

Number of octets including the Ethertype PDU header starting at APPID, and the length of the APDU (Application Protocol Data Unit). Therefore, the value of Length shall be 8 + m, where m is the length of the APDU and m is less than 1493. Frames with inconsistent or invalid length field shall be discarded.

5.3.3.4.4 Reserved 1

The structure of the Reserved 1 is defined in Figure 3.

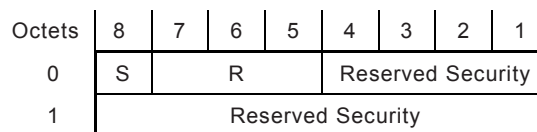

IEC 1788/11

Figure 3 – Reserved 1

S: Simulate. When this flag is set, the SampledValue telegram has been issued by a publisher located in a test device and not by the publisher as specified in the configuration file of the device.

R: Reserved. The three bits are reserved for future standardized application and shall be set to 0 as default.

Reserved security: See reserved 2 below.

5.3.3.4.5 Reserved 2

The Reserved 2 field and the “reserved security” of Reserved 1 field form a 28 bits word defined by the security standard IEC/TS 62351-6. It shall be used as defined when SampledValue telegram with security is transmitted, otherwise it shall be set to 0.

5.4 Restrictions

This mapping is restricted to the mapping of the ACSI model for the transmission of sampled values. The model applies to data sets. To get full benefit of IEC 61850, additional ACSI models need to be supported in accordance to IEC 61850-8-1. As an example, to enable the transmission of sampled value buffer, the associated control block attribute “SvEna” shall be written. However, if the client will read a list of available data sets or the contents of the data set, further models (for example logical device, logical node or data set) need to be supported.

Data sets for sampled values will be specified by using the XML language on engineering level in accordance with IEC 61850-6 to ensure interoperability.

For the transmission of sampled value data sets, the ASN.1 basic encoding rules (BER) will be used in combination with tags notation harmonised with the MMS grammar used in IEC 61850-8-1.

6 Mapping of IEC 61850-7-2 and IEC 61850-7-3 data attributes

The mapping of attributes and common data attributes to MMS are specified in IEC 61850-8-1.

For the transmission of sampled values the ASN.1, the basic encoding rules (BER) and the common data classes defined in IEC 61850-7-3 apply.

7 Mapping of IEC 61850-7-2 classes and services

7.1 Classes of SV data sets

If a client/server association based on MMS is used in addition to the transmission of SV data sets, the definitions of IEC 61850-8-1 apply for the following classes:

- server class model;
- association model;
- logical device model;
- logical node model;
- data class model;
- data set class model.

7.2 Definition of SV data sets

For the transmission of sampled values, the data sets are defined in logical node "LLN0". All sampled value data sets specification are part of the IED configuration description (ICD).

NOTE It is assumed that the data sets used for the transmission of sampled values may include data objects from more than one logical node and are therefore allocated in LLN0.

8 Mapping of the model for the transmission of sampled values

8.1 Overview

To ensure interoperability, the data sets for sampled values are specified in XML according to the definition in IEC 61850-6.

The sampled value class model provides reporting of sampled value data sets in an organised and time controlled way, so that transfer is very fast and time of transfer is kept constant. Sampled value control block for unicast and multicast defines the transmission characteristics of the data set they refer to. A detailed description is given in IEC 61850-7-2.

8.2 Mapping of the multicast sampled value control block class and services

8.2.1 Multicast sampled value control block definition

The sampled value control block, as defined in IEC 61850-7-2, shall be pre-defined by configuration or shall be mapped to an MMS Multicast sampled value control block (MSVCB) as defined in Table 9. All MSVCB components shall be of the functional constraint “MS”.

Table 9 – MMS TypeDescription definition for MSVCB MMS structure

MMS component name	MMS TypeDescription	r/w	m/o	Condition	Comments
MsvCBNam	Identifier	r	m		MMS Identifier of the structure of the MsvCBName within the MMS object named: LLN0\$MV e.g. LLN0\$MS\$<MsvCBNam>
MsvCBRef	Visible-string	r	m		The value of this component shall contain the IEC Reference of the MsvCB. e.g. <MMSDomain>/LLN0\$MS\$<MsvCBNam>
SvEna	Boolean	r/w	m		TRUE = transmission of sampled value buffer is activated. FALSE = transmission of sampled value buffer is deactivated.
MsvID	Visible-string	r	m		System-wide unique identification.
DatSet	Visible-string	r	m		The value of this component shall contain the IEC reference of the DataSet conveyed by the MsvCB. This ObjectReference shall be limited to VMD or Domain scoped NamedVariableLists.
ConfRev	Integer	r	m		Count of configuration changes regard to MSVCB.
SmpRate	Integer	r	m		Amount of samples (default per nominal period, see SmpMod).
OptFlds	BitString				
refresh-time	Boolean	r	m		TRUE = SV buffer contains the attribute “RefrTm”. FALSE = attribute “RefrTm” is not available in the SV buffer.
sample-synchronised	Boolean	r	m		Value will be ignored. Kept to ensure backward compatibility to IEC 61850-9-2 edition 1.0
sample-rate	Boolean	r	m		TRUE = SV buffer contains the attribute “SmpRate”. FALSE = attribute “SmpRate” is not available in the SV buffer.

MMS component name	MMS TypeDescription	r/w	m/o	Condition	Comments
data-set	Boolean	r	m		TRUE = SV buffer contains the attribute "DatSet". FALSE = attribute "DatSet" is not available in the SV buffer.
security	Boolean	r	M		Mapping specific attribute. TRUE = SV buffer contains the attribute "Security". FALSE = attribute "Security" is not available in the SV buffer.
SmpMod	Enumerated	r	O		smpMod specifies 0 = samples per nominal period (DEFAULT) 1 = samples per second 2 = seconds per sample If not available (backward compatibility) the default value is 0.
DstAddress	See Table 10		M		Mapping specific attribute.
noASDU	Integer	r	M		Mapping specific attribute. Number of ASDU concatenated into one APDU.

Table 10 – DstAddress structure

MMS component name	MMS TypeDescription	r/w	m/o	Condition	Comments
Addr	OCTET-STRING	r	M		Length is 6 octets and contains the value of the destination media access control (MAC) address to which the SV message is to be sent. If DstAddress is member of a MSVCB, the address shall be an Ethernet address that has the multicast bit set to TRUE. In order to facilitate the network traffic filtering, it is recommended to use different Ethernet addresses for each DstAddress. If DstAddress is member of a USVCB, the address shall be the Ethernet address of the SV subscriber. See Annex B for multicast addressing recommendations
PRIORITY	Unsigned8	r	M		Range of values shall be limited from 0 to 7.
VID	Unsigned16	r/w	M		Range of values shall be limited from 0 to 4095.
APPID	Unsigned16	r	M		As defined in 5.3.3.

8.2.2 MSV Services

See Table 11.

Table 11 – Mapping of multicast sampled value services

Services of MSVCB Class	Service
SendMSVMessage	Transmission of MSV messages is mapped directly on data link layer as defined in 8.4 and 8.5
GetMSVCBValue	Mapped to MMS read service
SetMSVCBValue	Mapped to MMS write service

8.3 Mapping of the unicast sampled value control block class and services

8.3.1 Unicast sampled value control block definition

The sampled value control block, as defined in IEC 61850-7-2, shall be pre-defined by configuration or shall be mapped to an MMS unicast sampled value control block (USVCB) as defined in Table 12. All USVCB components shall be of the functional constraint “US”.

Table 12 – MMS TypeDescription definition for USVCB MMS structure

MMS component name	MMS type description	r/w	m/o	Condition	Comments
UsvCBNam	Identifier	r	M		MMS Identifier of the structure of the UsvCBName within the MMS object named: LLN0\$MV e.g. LLN0\$US\$<UsvCBNam>
UsvCBRef	Visible-string	r	M		The value of this component shall contain the IEC Reference of the UsvCB. e.g. “<MMSDomain>/LLN0\$US\$<UsvCBNam>”
SvEna	Boolean	r/w	M		TRUE = transmission of sampled value buffer is activated. FALSE = transmission of sampled value buffer is deactivated.
Resv	Boolean	r/w	M		TRUE = USVCB is exclusively reserved for the client that has set this value to TRUE.
UsvID	Visible-string	r	M		System-wide unique identification.
DatSet	Visible-string	r	M		The value of this component shall contain the IEC Reference of the DataSet conveyed by the UsvCB. This ObjectReference shall be limited to VMD or Domain scoped NamedVariableLists.
ConfRev	Integer	r	M		Count of configuration changes regard to USVCB.
SmpRate	Integer	r	M		Amount of samples (default per nominal period see SmpMod).
OptFlds	BitString				
refresh-time	Boolean	r	M		TRUE = SV buffer contains the attribute “RefrTm”. FALSE = attribute “RefrTm” is not available in the SV buffer.
sample-synchronised	Boolean	r	M		Value will be ignored. Kept to ensure backward compatibility to IEC 61850-9-2 edition 1.0
sample-rate	Boolean	r	M		TRUE = SV buffer contains the attribute “SmpRate”. FALSE = attribute “SmpRate” is not available in the SV buffer.
data-set	Boolean	r	M		TRUE = SV buffer contains the attribute “DatSet”. FALSE = attribute “DatSet” is not available in the SV buffer.
security	Boolean	r	M		Mapping specific attribute. TRUE = SV buffer contains the attribute “Security”. FALSE = attribute “Security” is not available in the SV buffer.

MMS component name	MMS type description	r/w	m/o	Condition	Comments
SmpMod	Enumerated	r	O		smpMod specifies 0 = samples per nominal period (DEFAULT) 1 = samples per second 2 = seconds per sample If not available (backward compatibility) the default value is 0.
DstAddress	See Table 10		M		Mapping specific attribute.
noASDU	Integer	r	M		Mapping specific attribute. Number of ASDU concatenated into one APDU.

8.3.2 USV Services

See Table 13.

Table 13 – Mapping of unicast sampled value services

Services of USVCB class	Service
SendUSVMessage	Transmission of USV messages is mapped directly on data link layer as defined in 8.4 and 8.5
GetUSVCBValue	Mapped to MMS read service
SetUSVCBValue	Mapped to MMS write service

8.4 Mapping of the update of the sampled value buffer

As specified in IEC 61850-7-2, the communication system is responsible to update the buffer of the subscriber.

The update is directly mapped to an ethertype reserved for IEC 61850 applications based on ISO/IEC 8802-3 MAC – Sublayer.

The communication stack used does not provide the following functionality.

- Initiating and checking the update of the sampled value buffer over the communication link. Optionally concatenating the update of more than one buffer into the same link layer frame. This is application layer functionality.
- Encoding the abstract data types. This is presentation layer functionality.
- Concatenating the update of more than one transmission buffer into the same link layer frame as transport layer functionality is not supported. The opposite, to segment the update of one buffer to several link layer frames is not considered, since the maximum frame length of the link layer protocols is sufficient.
- Translating the logical address of the subscriber in a physical MAC address.

Therefore, the additional definitions of 8.5 apply.

8.5 Additional definitions for the transmission of sampled values

8.5.1 Application layer functionality

The mapping provides the capability to concatenate more than one ASDU into one APDU before the APDU is posted into the transmission buffer. The numbers of ASDUs which will be concatenated into one APDU are configurable and related to the sample rate. The

concatenation of ASDUs is not dynamically changeable in order to reduce the implementation complexity. When concatenating several ASDUs into one frame, the ASDU with the oldest samples is the first one in the frame.

Details are shown in Figure 4.

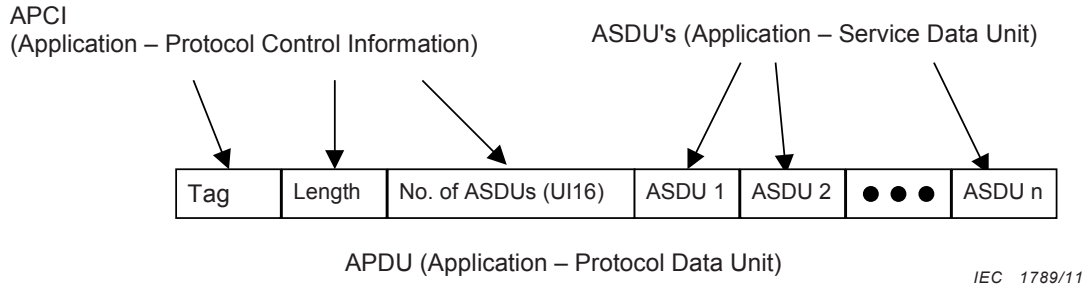

Figure 4 – Concatenation of several ASDU's into one frame

ASN.1 grammar in relation with the basic encoding rules (BER) is used to encode the sampled value messages for transmission on ISO/IEC 8802-3.

8.5.2 Presentation layer functionality

For the transmission, the sampled value buffer is encoded as specified in the Table 14.

Table 14 – Encoding for the transmission of the sampled value buffer

```
IEC61850 DEFINITIONS ::= BEGIN
IMPORTS Data FROM ISO-IEC-9506-2
IEC 61850-9-2 Specific Protocol ::= CHOICE {
  savPdu    [APPLICATION 0] IMPLICIT SavPdu,
```

Abstract buffer format according to IEC 61850-7-2		Coding in IEC 61850-9-2	Comments
Attribute name	Attribute type	ASN.1 basic encoding rules (BER) SavPdu ::= SEQUENCE {	
		noASDU [0] IMPLICIT INTEGER (1..65535),	Mapping specific attribute. Number of ASDUs, which will be concatenated into one APDU.
		security [1] ANY OPTIONAL,	Mapping specific attribute. Reserved for future definition (e.g. digital signature).
		asdu [2] IMPLICIT SEQUENCE OF ASDU }	1 to <i>n</i> number of ASDUs as specified before.
		ASDU ::= SEQUENCE {	
MsvID or UsvID	VISIBLE STRING	svID [0] IMPLICIT VisibleString,	Should be a system-wide unique identification.
DatSet	ObjectReference	datset [1] IMPLICIT VisibleString OPTIONAL,	Value from the MSVCB or USVCB

Abstract buffer format according to IEC 61850-7-2		Coding in IEC 61850-9-2	Comments
Attribute name	Attribute type	ASN.1 basic encoding rules (BER) SavPdu ::= SEQUENCE {	
SmpCnt	INT16U	smpCnt [2] IMPLICIT OCTET STRING (SIZE(2)),	Will be incremented each time a new sampling value is taken. The counter shall be set to zero if the sampling is synchronised by clock signal and the synchronising signal occurs. When sync pulses are used to synchronise merging units, the counter shall be set to zero with every sync pulse. The value 0 shall be given to the data set where the sampling of the primary current coincides with the sync pulse. The OCTET STRING is interpreted as INT16U as defined in Table 15.
ConfRev	INT32U	confRev [3] IMPLICIT OCTET STRING (SIZE(4)),	Value from the MSVCB or USVCB. The OCTET STRING is interpreted as INT32U as defined in Table 15.
RefrTm	TimeStamp	refrTm [4] IMPLICIT UtcTime OPTIONAL,	RefrTm contains the refresh time of the SV buffer.
SmpSynch	INT8U	smpSynch [5] IMPLICIT OCTET STRING (SIZE(1)),	0= SV are not synchronised by an external clock signal. 1= SV are synchronised by a clock signal from an unspecified local area clock. 2= SV are synchronised by a global area clock signal (time traceable). 5 to 254= SV are synchronised by a clock signal from a local area clock identified by this value. 3;4;255= Reserved values – Do not use.
SmpRate	INT16U	smpRate [6] IMPLICIT OCTET STRING (SIZE(2)) OPTIONAL,	Value from the MSVCB or USVCB. The OCTET STRING is interpreted as INT16U as defined in Table 15.
Sample [1..n]	Type depends on the CDC defined in IEC 61850-7-3.	sample [7] IMPLICIT OCTET STRING (SIZE(n))	List of data values related to the data set definition. For the encoding of the Data, the rules for the encoding of the basic data types shall apply as defined in Table 15. The SIZE (n) is the cumulated size of all the data conveyed as defined in the DataSet.
SmpMod	INT16U	smpMod [8] IMPLICIT OCTET STRING (SIZE(2)) OPTIONAL }	Value from the MSVCB or USVCB. The OCTET STRING is interpreted as INT16U as defined in Table 15.

NOTE The usage of the OptFlds attribute according to IEC 61850-7-2 is not necessary, because the relating attributes RefrTm, security, SmpRate and DataSet will be signed as optional via the ASN.1 attribute directly.

... }

END

For the tag definition of basic data types, see 8.6.

8.6 Definitions for basic data types – Presentation layer functionality

Table 15 shows the encoding for the basic data types used for the Data values referenced by the data set members.

Table 15 – Encoding for the basic data types

Data types according to IEC 61850-7-2	Encoding in data set	Comments
BOOLEAN	8 Bit set to 0 FALSE; anything else = TRUE	
INT8	8 Bit Big Endian	signed
INT16	16 Bit Big Endian	signed
INT32	32 Bit Big Endian	signed
INT64	64 Bit Big Endian	signed
INT8U	8 Bit Big Endian	unsigned
INT16U	16 Bit Big Endian	unsigned
INT24U	24 Bit Big Endian	unsigned
INT32U	32 Bit Big Endian	unsigned
FLOAT32	32 Bit IEEE Floating Point (IEEE 754)	
FLOAT64	64 Bit IEEE Floating Point (IEEE 754)	
ENUMERATED	32 Bit Big Endian	
CODED ENUM	32 Bit Big Endian	
OCTET STRING	20 Bytes ASCII Text, Null terminated	
VISIBLE STRING	35 Bytes ASCII Text, Null terminated	
UNICODE STRING	20 Bytes ASCII Text, Null terminated	
ObjectName	20 Bytes ASCII Text, Null terminated	
ObjectReference	20 Bytes ASCII Text, Null terminated	
TimeStamp	64 Bit Timestamp as defined in IEC 61850-8-1	
EntryTime	48 Bit Timestamp as defined in IEC 61850-8-1	
Data types according to IEC 61850-8-1	Encoding in data set	Comments
BITSTRING	32 Bit Big Endian	

9 Conformance

9.1 Notation

For Subclause 9.2 to Clause 11, see the abbreviations given in Clause 4.

9.2 PICS

9.2.1 Profile conformance

Table 16 and Table 17 define the basic conformance statement.

Table 16 – PICS for A-Profile support

		Client		Server		Value/comment
		F/S		F/S		
A1	Client/Server A-Profile	c1		c1		Refer to 5.2
A2	SV A-Profile	c2		c2		Refer to 5.3
<p>c1 – Shall be 'm' if support for any service specified in Table 1 is declared within the ACSI basic conformance statement.</p> <p>c2 – Shall be 'm' if support for any service specified in Table 4 is declared within the ACSI basic conformance statement.</p>						

Table 17 – PICS for T-Profile support

		Client		Server		Value/comment
		F/S		F/S		
T1	TCP/IP T-Profile	c1		c1		
T2	SV T-Profile	c2		c2		
<p>c1 – Shall be 'm' if support for A1 is declared. Otherwise, shall be 'i'</p> <p>c2 – Shall be 'm' if support for A2 is declared. Otherwise, shall be 'i'.</p>						

9.2.2 SV Services

This subclause describes the protocol implementation conformance statement for sampled values services based on the IEC 61850-7-2 basic conformance statement. See Table 18.

Table 18 – SV conformance statement

Services	Client/ subscriber	Server/ publisher	Value/comment
Multicast			
SendMSVMessage	c1	c1	
GetMSVCBValues	c2	c2	
SetMSVCBValues	c3	c3	
Unicast			
SendUSVMessage	c1	c1	
GetUSVCBValues	c2	c2	
SetUSVCBValues	c3	c3	
<p>c1 – Shall declare 'm' for at least one (MSV or USV) as declared within ACSI basic conformance statement.</p> <p>c2 – Shall be 'o' as declared within ACSI basic conformance statement. See IEC 61850-8-1, Table 117 "Read Conformance Statement".</p> <p>c3 – Shall be 'o' as declared within ACSI basic conformance statement. See IEC 61850-8-1, Table 118 "Write Conformance Statement".</p>			

10 Substation configuration language (SCL)

Conforming implementations shall support the substation configuration language as defined in IEC 61850-6 for exchange between engineering tools.

11 SCSM specific address element definitions

This clause defines the xs:string types that are allowed for the SV addressing as type parameters of the P element of the Address element. The values and character restrictions are defined in Table 19.

Table 19 – Definitions for SV SCL

P-type designation	Description	m/o	Restrictions/comments
MAC-Address	Media Access Address value	m	Shall be 6 groups of 2 visible characters separated by hyphens (-). Characters shall be limited to 0 to 9 and A to F.
APPID	Application Identifier	o	Shall be 4 characters. Characters shall be limited to 0 to 9 and A to F.
VLAN-PRIORITY	VLAN User Priority	c1	Shall be a single character. Characters shall be limited to 0 to 7.
VLAN-ID	VLAN ID	o	Shall be 3 characters. Characters shall be limited to 0 to 9 and A to F.
c1 – Shall only be present if VLAN is also present.			

Annex A (informative)

ISO/IEC 8802-3 frame format and ASN.1 basic encoding rules

A.1 ISO/IEC 8802-3 frame format

See Figures A.1, A.2 and A.3.

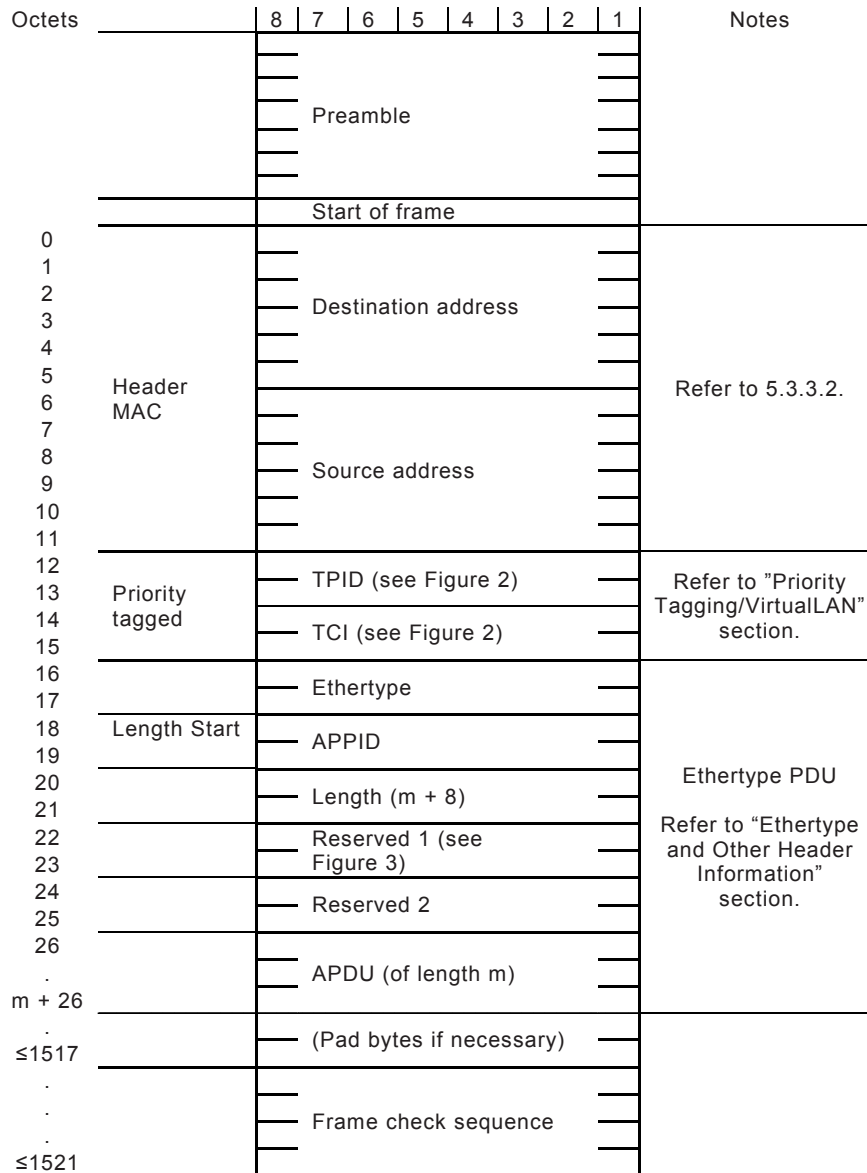

IEC 1790/11

Figure A.1 – ISO/IEC 8802-3 frame format – No link redundancy

Octets	8	7	6	5	4	3	2	1	Notes
	Preamble								
	Start of frame								
0	Destination address								Refer to 5.3.3.2.
1									
2									
3									
4									
5									
6	Source address								Refer to 5.3.3.2.
7									
8									
9									
10									
11									
12	TPID (see Figure 2)								Refer to "Priority Tagging/VirtualLAN" section.
13									
14									
15	TCl (see Figure 2)								Refer to "Priority Tagging/VirtualLAN" section.
16									
17	HSR Tag 0x892F Path – Size H Size L Sequence number H Sequence Number L								See IEC 62439-3 (HSR optional field).
18									
19									
20									
21									
22	Ethertype								Ethertype PDU Refer to "EtherType and Other Header Information" section.
23									
24	APPID								
25									
26	Length (m + 8)								
27									
28	Reserved 1 (see Figure 3)								
29									
30	Reserved 2								
31									
32	APDU (of length m)								
m + 32									
≤1523	(Pad bytes if necessary)								
.									
.	Frame check sequence								
≤1527									

IEC 1791/11

Figure A.2 – ISO/IEC 8802-3 frame format – Link redundancy: HSR

Octets	8	7	6	5	4	3	2	1	Notes
	Preamble								
	Start of frame								
0	Destination address								Refer to 5.3.3.2.
1									
2									
3									
4									
5									
6	Header MAC								Refer to 5.3.3.2.
7	Source address								
8									
9									
10									
11									
12									Priority tagged
13	TPID (see Figure 2)								
14	TCI (see Figure 2)								
15	Ethertype								Refer to "Ethertype and Other Header Information" section.
16	Length Start								
17	APPID								
18	Length (m + 8)								
19	Reserved 1 (see Figure 3)								
20	Reserved 2								
21	APDU (of length m)								
22	(Pad bytes if necessary)								
m + 26	Link redundancy trailer								See IEC 62439-3 (PRP optional field).
	Sequence number H								
	Sequence Number L								
	Path – Size H								
	Size L								
	0x88								
	0xFB								
	Frame check sequence								
≤1527									

Figure A.3 – ISO/IEC 8802-3 frame format – Link redundancy: PRP

A.2 ASN.1 basic encoding rules (BER)

ASN.1 basic encoding rules (as specified in ISO/IEC 8825-1) will be used for encoding and decoding of sampled values. The main encoding principles are shown as an overview.

The BER transfer syntax has the format of a triplet TLV (Type, Length, Value) or (Tag, Length, Value) as shown in Figure A.4.

All fields (T, L, V) are series of octets. The value V can be a triplet TLV itself, if it is constructed.

The transfer syntax is octet-based and “big endian”-oriented. The length field L defines the length of each TLV triplet.

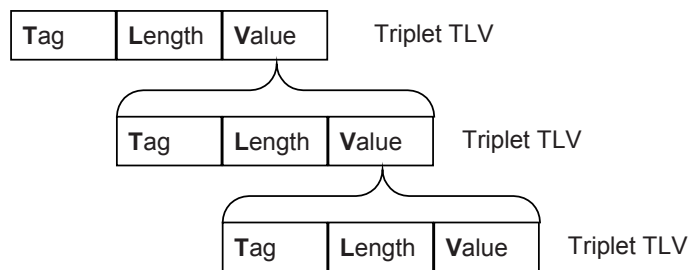

IEC 1793/11

Figure A.4 – Basic encoding rules format

The tag octets correspond to the encoding of the tag of the value type. Figure A.5 shows the two formats of the tag octets T.

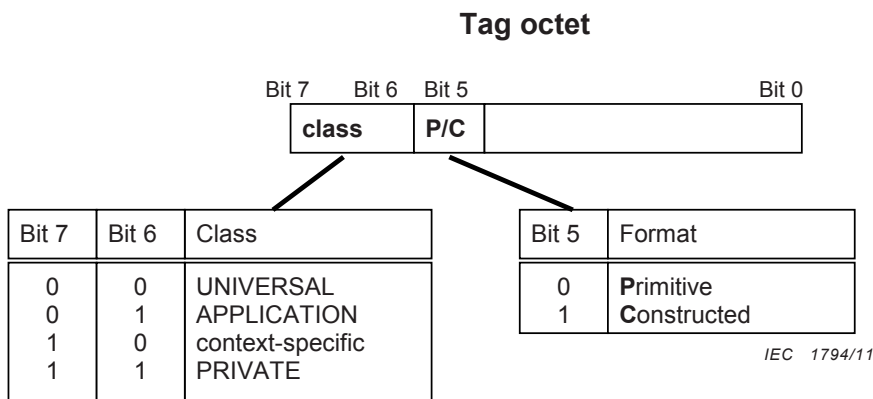

IEC 1794/11

Figure A.5 – Format of the tag octets

A.3 Example for an ASN.1 coded APDU frame structure

The example in Figure A.6 shows the APDU frame structure with 4 concatenated ASDUs.

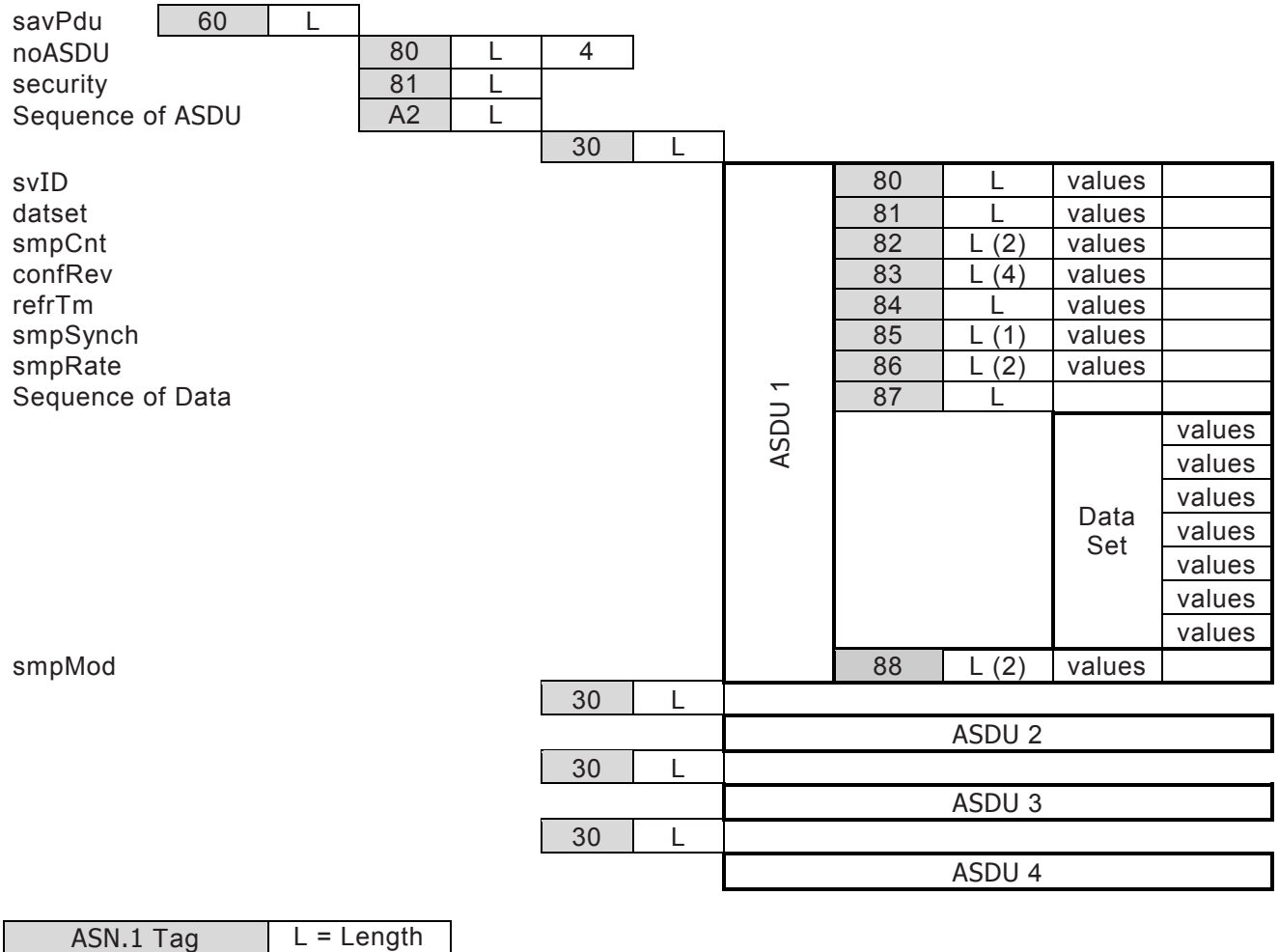

Figure A.6 – Example for an ASN.1 coded APDU frame structure

Annex B (informative)

Multicast address selection

In order to increase the overall performance of multicast message reception (for example GOOSE, GSSE, and Sampled Values), it is preferable to have the media access controller (MAC) hardware perform the filtering. The hash algorithms in the various integrated circuits do vary. It is recommended, as a system integrator, to evaluate the impact of these algorithms when assigning destination multicast addresses.

Vendors of IEC 61850-8-1 or IEC 61850-9-2 implementations that send these types of messages should provide recommendations of addressing based upon the MAC IC's hash algorithms. One such recommendation might appear as follows:

The multicast addresses (octet string of size 6) used within this standard will have the following structure.

- The first three octets are assigned by IEEE with 01-0C-CD.
- The fourth octet will be 01 for GOOSE, 02 for GSSE, and 04 for multicast sampled values.
- The last two octets will be used as individual addresses assigned by range defined in Table B.1.

Table B.1 – Recommended multicast addressing example

Service	Recommended address range assignments	
	Starting address (hexadecimal)	Ending address (hexadecimal)
GOOSE	01-0C-CD-01-00-00	01-0C-CD-01-01-FF
GSSE	01-0C-CD-02-00-00	01-0C-CD-02-01-FF
Multicast sampled values	01-0C-CD-04-00-00	01-0C-CD-04-01-FF

British Standards Institution (BSI)

BSI is the national body responsible for preparing British Standards and other standards-related publications, information and services.

BSI is incorporated by Royal Charter. British Standards and other standardization products are published by BSI Standards Limited.

About us

We bring together business, industry, government, consumers, innovators and others to shape their combined experience and expertise into standards-based solutions.

The knowledge embodied in our standards has been carefully assembled in a dependable format and refined through our open consultation process. Organizations of all sizes and across all sectors choose standards to help them achieve their goals.

Information on standards

We can provide you with the knowledge that your organization needs to succeed. Find out more about British Standards by visiting our website at bsigroup.com/standards or contacting our Customer Services team or Knowledge Centre.

Buying standards

You can buy and download PDF versions of BSI publications, including British and adopted European and international standards, through our website at bsigroup.com/shop, where hard copies can also be purchased.

If you need international and foreign standards from other Standards Development Organizations, hard copies can be ordered from our Customer Services team.

Subscriptions

Our range of subscription services are designed to make using standards easier for you. For further information on our subscription products go to bsigroup.com/subscriptions.

With **British Standards Online (BSOL)** you'll have instant access to over 55,000 British and adopted European and international standards from your desktop. It's available 24/7 and is refreshed daily so you'll always be up to date.

You can keep in touch with standards developments and receive substantial discounts on the purchase price of standards, both in single copy and subscription format, by becoming a **BSI Subscribing Member**.

PLUS is an updating service exclusive to BSI Subscribing Members. You will automatically receive the latest hard copy of your standards when they're revised or replaced.

To find out more about becoming a BSI Subscribing Member and the benefits of membership, please visit bsigroup.com/shop.

With a **Multi-User Network Licence (MUNL)** you are able to host standards publications on your intranet. Licences can cover as few or as many users as you wish. With updates supplied as soon as they're available, you can be sure your documentation is current. For further information, email bsmusales@bsigroup.com.

BSI Group Headquarters

389 Chiswick High Road London W4 4AL UK

Revisions

Our British Standards and other publications are updated by amendment or revision.

We continually improve the quality of our products and services to benefit your business. If you find an inaccuracy or ambiguity within a British Standard or other BSI publication please inform the Knowledge Centre.

Copyright

All the data, software and documentation set out in all British Standards and other BSI publications are the property of and copyrighted by BSI, or some person or entity that owns copyright in the information used (such as the international standardization bodies) and has formally licensed such information to BSI for commercial publication and use. Except as permitted under the Copyright, Designs and Patents Act 1988 no extract may be reproduced, stored in a retrieval system or transmitted in any form or by any means – electronic, photocopying, recording or otherwise – without prior written permission from BSI. Details and advice can be obtained from the Copyright & Licensing Department.

Useful Contacts:

Customer Services

Tel: +44 845 086 9001

Email (orders): orders@bsigroup.com

Email (enquiries): cservices@bsigroup.com

Subscriptions

Tel: +44 845 086 9001

Email: subscriptions@bsigroup.com

Knowledge Centre

Tel: +44 20 8996 7004

Email: knowledgecentre@bsigroup.com

Copyright & Licensing

Tel: +44 20 8996 7070

Email: copyright@bsigroup.com



...making excellence a habit.™