



BSI Standards Publication

Measurement of DC magnetic, AC magnetic and AC electric fields from 1 Hz to 100 kHz with regard to exposure of human beings

Part 1: Requirements for measuring
instruments

National foreword

This British Standard is the UK implementation of EN 61786-1:2014. It is identical to IEC 61786-1:2013.

The UK participation in its preparation was entrusted to Technical Committee GEL/106, Human exposure to low frequency and high frequency electromagnetic radiation.

A list of organizations represented on this committee can be obtained on request to its secretary.

This publication does not purport to include all the necessary provisions of a contract. Users are responsible for its correct application.

© The British Standards Institution 2014.
Published by BSI Standards Limited 2014

ISBN 978 0 580 74538 6
ICS 17.220.20

Compliance with a British Standard cannot confer immunity from legal obligations.

This British Standard was published under the authority of the Standards Policy and Strategy Committee on 30 April 2014.

Amendments/corrigenda issued since publication

| Date | Text affected |
|------|---------------|
|------|---------------|

EUROPEAN STANDARD
NORME EUROPÉENNE
EUROPÄISCHE NORM

EN 61786-1

March 2014

ICS 17.220.20

English version

**Measurement of DC magnetic, AC magnetic and AC electric fields from 1 Hz to 100 kHz with regard to exposure of human beings -
Part 1: Requirements for measuring instruments
(IEC 61786-1:2013)**

Mesure de champs magnétiques continus et de champs magnétiques et électriques alternatifs dans la plage de fréquences de 1 Hz à 100 kHz dans leur rapport à l'exposition humaine -
Partie 1: Exigences applicables aux instruments de mesure
(CEI 61786-1:2013)

Messung von magnetischen Gleichfeldern und von elektrischen und magnetischen Wechselfeldern von 1 Hz bis 100 kHz im Hinblick auf die Exposition von Personen -
Teil 1: Anforderungen an Messgeräte
(IEC 61786-1:2013)

This European Standard was approved by CENELEC on 2014-01-16. CENELEC members are bound to comply with the CEN/CENELEC Internal Regulations which stipulate the conditions for giving this European Standard the status of a national standard without any alteration.

Up-to-date lists and bibliographical references concerning such national standards may be obtained on application to the CEN-CENELEC Management Centre or to any CENELEC member.

This European Standard exists in three official versions (English, French, German). A version in any other language made by translation under the responsibility of a CENELEC member into its own language and notified to the CEN-CENELEC Management Centre has the same status as the official versions.

CENELEC members are the national electrotechnical committees of Austria, Belgium, Bulgaria, Croatia, Cyprus, the Czech Republic, Denmark, Estonia, Finland, Former Yugoslav Republic of Macedonia, France, Germany, Greece, Hungary, Iceland, Ireland, Italy, Latvia, Lithuania, Luxembourg, Malta, the Netherlands, Norway, Poland, Portugal, Romania, Slovakia, Slovenia, Spain, Sweden, Switzerland, Turkey and the United Kingdom.

CENELEC

European Committee for Electrotechnical Standardization
Comité Européen de Normalisation Electrotechnique
Europäisches Komitee für Elektrotechnische Normung

CEN-CENELEC Management Centre: Avenue Marnix 17, B - 1000 Brussels

Foreword

The text of document 106/292/FDIS, future edition 1 of IEC 61786-1, prepared by IEC TC 106, Methods for the assessment of electric, magnetic and electromagnetic fields associated with human exposure" was submitted to the IEC-CENELEC parallel vote and approved by CENELEC as EN 61786-1:2014.

The following dates are fixed:

- latest date by which the document has to be implemented at national level by publication of an identical national standard or by endorsement (dop) 2014-10-16
- latest date by which the national standards conflicting with the document have to be withdrawn (dow) 2017-01-16

Attention is drawn to the possibility that some of the elements of this document may be the subject of patent rights. CENELEC [and/or CEN] shall not be held responsible for identifying any or all such patent rights.

Endorsement notice

The text of the International Standard IEC 61786-1:2013 was approved by CENELEC as a European Standard without any modification.

In the official version, for Bibliography, the following notes have to be added for the standards indicated:

| | | |
|--------------------|------|---|
| IEC 62110:2009 | NOTE | Harmonised as EN 62110:2009 (not modified). |
| ISO 80000-1:2009 | NOTE | Harmonised as EN ISO 80000-1:2013 (not modified). |
| ISO/IEC 17025:2005 | NOTE | Harmonised as EN ISO/IEC 17025:2005 (not modified). |

Annex ZA (normative)

Normative references to international publications with their corresponding European publications

The following documents, in whole or in part, are normatively referenced in this document and are indispensable for its application. For dated references, only the edition cited applies. For undated references, the latest edition of the referenced document (including any amendments) applies.

NOTE When an international publication has been modified by common modifications, indicated by (mod), the relevant EN/HD applies.

| <u>Publication</u> | <u>Year</u> | <u>Title</u> | <u>EN/HD</u> | <u>Year</u> |
|--------------------|-------------|--|--------------|-------------|
| IEC 61000-3-2 | - | Electromagnetic compatibility (EMC) - Part 3-2: Limits - Limits for harmonic current emissions (equipment input current ≤ 16 A per phase) | EN 61000-3-2 | - |
| IEC 61000-4-2 | - | Electromagnetic compatibility (EMC) - Part 4-2: Testing and measurement techniques - Electrostatic discharge immunity test | EN 61000-4-2 | - |
| IEC 61000-4-3 | - | Electromagnetic compatibility (EMC) - Part 4-3: Testing and measurement techniques - Radiated, radio-frequency, electromagnetic field immunity test | EN 61000-4-3 | - |
| IEC 61000-4-4 | - | Electromagnetic compatibility (EMC) - Part 4-4: Testing and measurement techniques - Electrical fast transient/burst immunity test | EN 61000-4-4 | - |
| IEC 61000-4-6 | - | Electromagnetic compatibility (EMC) - Part 4-6: Testing and measurement techniques - Immunity to conducted disturbances, induced by radio-frequency fields | EN 61000-4-6 | - |
| IEC 61000-4-8 | - | Electromagnetic compatibility (EMC) - Part 4-8: Testing and measurement techniques - Power frequency magnetic field immunity test | EN 61000-4-8 | - |
| CISPR 11 (mod) | - | Industrial, scientific and medical equipment - Radio-frequency disturbance characteristics - Limits and methods of measurement | EN 55011 | - |
| ISO/IEC Guide 98-3 | - | Uncertainty of measurement - Part 3: Guide to the expression of uncertainty in measurement (GUM:1995) | - | - |
| IEC Guide 108 | - | Guidelines for ensuring the coherency of IEC publications - Application of horizontal standards | - | - |

CONTENTS

| | | |
|-------|---|----|
| 1 | Scope | 6 |
| 2 | Normative references | 6 |
| 3 | Terms and definitions | 7 |
| 3.1 | Meters | 7 |
| 3.2 | Meter characteristics | 8 |
| 3.3 | Field characteristics | 9 |
| 3.4 | Measurements | 10 |
| 4 | Symbols | 11 |
| 5 | Instrumentation specifications | 12 |
| 5.1 | General | 12 |
| 5.2 | Measurement uncertainty | 12 |
| 5.3 | Magnitude range | 13 |
| 5.4 | Pass-band | 13 |
| 5.5 | Operating temperature and humidity ranges | 13 |
| 5.6 | Power supplies | 13 |
| 5.7 | Readability of scale | 14 |
| 5.8 | Instrument dimensions and choice of probe | 14 |
| 5.8.1 | General schema | 14 |
| 5.8.2 | Magnetic field meter | 14 |
| 5.8.3 | Electric field meter | 15 |
| 5.8.4 | Support for electric field meter | 15 |
| 5.9 | Electromagnetic compatibility | 15 |
| 5.9.1 | Immunity | 15 |
| 5.9.2 | Emissions | 16 |
| 5.10 | Crest factor | 17 |
| 5.11 | Durability | 17 |
| 5.12 | Weight | 17 |
| 5.13 | Instrumentation choice | 18 |
| 6 | Calibration | 18 |
| 6.1 | General | 18 |
| 6.2 | Calibration procedure | 18 |
| 6.2.1 | General | 18 |
| 6.2.2 | Magnetic field calibration system | 18 |
| 6.2.3 | Electric field calibration system | 19 |
| 6.2.4 | Three-axis probes calibration | 19 |
| 6.2.5 | Calibration values | 19 |
| 6.2.6 | Calibration uncertainty | 20 |
| 6.3 | Calibration documentation | 20 |
| 7 | Verification | 21 |
| | Annex A (normative) Calibration methods | 22 |
| | Annex B (informative) Example of calibration uncertainty | 33 |
| | Annex C (informative) General characteristics of magnetic and electric fields | 35 |
| | Annex D (informative) Magnetic flux density meters (magnetic field meters) | 39 |

| | |
|---|----|
| Annex E (informative) Electric field strength meters (electric field meters) | 43 |
| Annex F (informative) Influence of humidity on electric field measurement | 47 |
| Annex G (informative) Units | 49 |
| Bibliography..... | 50 |
| | |
| Figure 1 – Schema of a field meter | 14 |
| Figure 2 – Insulating tripod and offset rod for an electric field probe (photograph RTE)..... | 15 |
| Figure 3 – Electric field measurement using a hand-held stick (photograph RTE)..... | 15 |
| Figure A.1 – Deviation in percentage departure of calculated axial field [7] | 22 |
| Figure A.2 – Coordinate system and geometry of rectangular loop of many turns of wire (see Equation (A. 1)) | 23 |
| Figure A.3 – Circular Helmholtz coils | 24 |
| Figure A.4 – Deviation in percentage of calculated B_z from centre value (see Equation (A.4)) | 25 |
| Figure A.5 – Schematic view of a circuit for calibration of magnetic field meter using a square loop to produce a known field | 25 |
| Figure A.6 – Diagram for voltage injection technique | 27 |
| Figure A.7 – Calculated normalized electric field at plate surfaces and midway between plates as a function of the normalized distance from the edge of the plate | 28 |
| Figure A.8 – Parallel plates system for calibrating free-body electric field meters..... | 30 |
| Figure A.9 – Arrangement with parallel plates orientated perpendicular to the floor..... | 31 |
| Figure A.10 – Diagram for current injection technique | 32 |
| Figure C.1 – Oscillating and rotating field quantities for cases of elliptical polarization, linear polarization, and circular polarization | 36 |
| Figure C.2 – Magnetic field from current in straight and circular conductors | 37 |
| Figure C.3 – Perturbation of electric field distribution B by a person (from IEC 62226-3-1)..... | 38 |
| Figure C.4 – Proximity effect with a 25 kV line and a building (from IEC 62110)..... | 38 |
| Figure D.1 – Schematic view of simple magnetic field meter with coil-type probe | 39 |
| Figure D.2 – Approximate equivalent circuit of a coil probe when connected to the detector | 41 |
| Figure E.1 – Single-axis free-body meter geometries | 44 |
| Figure E.2 – Designs for flat plate probes used with ground-referenced electric field meters | 45 |
| Figure F.1 – Test in the climatic chamber with the normal tripod (left) and the offset tripod (right) (photograph EDF R&D)..... | 47 |
| Figure F.2 – E field measured as a function of the humidity with a normal tripod..... | 48 |
| Figure F.3 – E field measured as a function of the humidity with an offset tripod..... | 48 |
| | |
| Table 1 – Mains terminal disturbance voltage limits for class B group 1 equipment measured on a test site..... | 17 |
| Table A.1 – Calculated normalized electric field values midway between plates and at plate surfaces | 30 |
| Table B.1 – Example of uncertainty calculation | 33 |

MEASUREMENT OF DC MAGNETIC, AC MAGNETIC AND AC ELECTRIC FIELDS FROM 1 Hz TO 100 kHz WITH REGARD TO EXPOSURE OF HUMAN BEINGS –

Part 1: Requirements for measuring instruments

1 Scope

This part of IEC 61786 provides guidance for measuring instruments used to measure the field strength of quasi-static magnetic and electric fields that have a frequency content in the range 1 Hz to 100 kHz and with DC magnetic fields to evaluate the exposure levels of the human body to these fields.

Sources of fields include devices that operate at power frequencies and produce power frequency and power frequency harmonic fields, as well as devices that produce fields within the frequency range of this document, including devices that produce static fields, and the earth's static magnetic field. The magnitude ranges covered by this standard are 0,1 μ T to 200 mT in AC (1 μ T to 10 T in DC) and 1 V/m to 50 kV/m for magnetic fields and electric fields, respectively.

When measurements outside this range are performed, most of the provisions of this standard will still apply, but special attention should be paid to specified uncertainty and calibration procedures.

Specifically, this standard

- defines terminology;
- identifies requirements on field meter specifications;
- indicates methods of calibration;
- defines requirements on instrumentation uncertainty;
- describes general characteristics of fields;
- describes operational principles of instrumentation.

NOTE Measurement methods that achieve defined goals pertaining to assessment of human exposure are described in IEC 61786-2

Sources of uncertainty during calibration are also identified. In regard to electric field measurements, this standard considers only the measurement of the unperturbed electric field strength at a point in free space (i.e. the electric field prior to the introduction of the field meter and operator) or above conducting surfaces.

This horizontal standard is primarily intended for use by technical committees in the preparation of standards in accordance with the principles laid down in IEC Guide 108.

One of the responsibilities of a technical committee is, wherever applicable, to make use of horizontal standards in the preparation of its publications. The contents of this horizontal standard will not apply unless specifically referred to or included in the relevant publications.

2 Normative references

The following documents, in whole or in part, are normatively referenced in this document and are indispensable for its application. For dated references, only the edition cited applies. For

undated references, the latest edition of the referenced document (including any amendments) applies.

IEC 61000-3-2, *Electromagnetic compatibility (EMC) – Part 3-2: Limits – Limits for harmonic current emissions (equipment input current ≤ 16 A per phase)*

IEC 61000-4-2, *Electromagnetic compatibility (EMC) – Part 4-2: Testing and measurement techniques – Electrostatic discharge immunity test*

IEC 61000-4-3, *Electromagnetic compatibility (EMC) - Part 4-3 : Testing and measurement techniques - Radiated, radio-frequency, electromagnetic field immunity test*

IEC 61000-4-4, *Electromagnetic compatibility (EMC) – Part 4-4: Testing and measurement techniques – Electrical fast transient/burst immunity test*

IEC 61000-4-6, *Electromagnetic compatibility (EMC) – Part 4-6: Testing and measurement techniques – Immunity to conducted disturbances, induced by radio-frequency fields*

IEC 61000-4-8, *Electromagnetic compatibility (EMC) – Part 4-8: Testing and measurement techniques – Power frequency magnetic field immunity test*

CISPR 11, *Industrial, scientific and medical equipment – Radio-frequency disturbance characteristics – Limits and methods of measurement*

ISO/IEC Guide 98-3, *Uncertainty of measurement – Part 3: Guide to the expression of uncertainty in measurement (GUM:1995)*

Guide 108, *Guidelines for ensuring the coherency of IEC publications – Application of horizontal standards*

3 Terms and definitions

For the purposes of this document, the following terms and definitions apply.

NOTE 1 Internationally accepted SI-units are used throughout the standard.

NOTE 2 For other units, see Annex G.

NOTE 3 Throughout this standard, the words "magnetic flux density" and "magnetic field" will be considered synonymous.

3.1 Meters

3.1.1

measuring instrument

device intended to be used to make measurements, alone or in conjunction with supplementary devices

[SOURCE: IEC 60050-300:2001, 311-03-01]

3.1.2

field meter

meter designed to measure electric, magnetic and electromagnetic fields

Note 1 to entry: Field meters usually consist of three parts: the probe, the detector circuit and the display.

3.1.3

probe

input device of a measuring instrument, generally made as a separate unit and connected to it by means of a flexible cable, which transmits the measurand in a suitable form

Note 1 to entry: A probe can be composed of one or several sensors.

[SOURCE: IEC 60050-300:2001, 313-09-11, modified – a note to entry has been added.]

3.1.4

detector

device for discerning the existence or variations of waves, oscillations or signals, usually for extracting information conveyed.

EXAMPLES Peak detector, rms detector

[SOURCE: IEC 60050-702:1992, 702-09-39, modified – the examples are different.]

3.1.5

free-body meter

meter that measures the unperturbed electric field strength at a point above the ground and is supported in space without conductive contact to ground

3.1.6

fluxgate magnetometer

instrument designed to measure magnetic fields by making use of the non-linear magnetic characteristics of a probe or sensing element that has a ferromagnetic core

3.1.7

ground reference meter

meter that measures the electric field at or close to the surface of the ground, frequently implemented by measuring the induced current or charge oscillating between an isolated electrode and ground.

Note 1 to entry: The isolated electrode is usually a plate located at ground level or slightly above the ground surface.

3.1.8

survey meter

lightweight battery-operated meter that gives a real time read-out and that can be held conveniently by hand in order to conduct survey type measurements in different locations

3.1.9

coil probe

magnetic flux density sensor comprised of a coil of wire that produces an induced voltage proportional to the time derivative of the magnetic field

3.1.10

Hall effect probe

magnetic flux density sensor containing an element exhibiting the Hall effect to produce a voltage proportional to the magnetic flux density

3.2 Meter characteristics

3.2.1

crest factor

ratio of the maximum absolute value of an alternating quantity to its root-mean-square value

[SOURCE: IEC 60050-103:2009, 103-14-57, modified – the original term was "peak factor" and the note has been deleted.]

3.2.2

crosstalk

the appearance of undesired energy in a channel, owing to the presence of a signal in another channel, caused by, for example induction, conduction or non-linearity

[SOURCE: IEC 60050-722:1992, 722-15-03]

3.2.3

frequency response

for a linear time-invariant system with a sinusoidal input variable in steady state the ratio of the phasor of the output variable to the phasor of the corresponding input variable, represented as a function of the angular frequency ω

[SOURCE: IEC 60050-351:2006, 351-24-33, modified – the note in the original has been deleted.]

3.2.4

isotropy of the probe

a measure of the degree to which the response of a field probe is independent of the polarization and direction of propagation of the incident field

3.2.5

pass-band

frequency band throughout which the attenuation is less than a specified value

[SOURCE: IEC 60050-151:2001, 151-13-52]

3.2.6

root-mean-square value

rms value

1) for n quantities x_1, x_2, \dots, x_n , positive square root of the mean value of their squares:

$$X_q = \left[\frac{1}{n} (x_1^2 + x_2^2 + \dots + x_n^2) \right]^{1/2} \quad (1)$$

2) for a quantity x depending of a variable t , positive square root of the mean value of the square of the quantity taken over a given interval $[t_0, t_0+T]$ of the variable

$$X_q = \left[\frac{1}{T} \int_{t_0}^{t_0+T} [x(t)]^2 dt \right]^{1/2} \quad (2)$$

Note 1 to entry: The rms value of a periodic quantity is usually taken over an integration interval the range of which is the period multiplied by a natural number

[SOURCE: IEC 60050-103:2009, 103-02-02, modified – the second note in the original definition has been deleted.]

3.3 Field characteristics

3.3.1

unperturbed field

field at a point that would exist in the absence of persons or movable objects

3.3.2

nearly uniform field

field in area where the resultant field over the cross-sectional area of the probe does not change more than 1%

3.3.3

quasi-static field

field that satisfies the condition $f \ll \frac{c}{l}$ (i.e. wavelength $\gg l$), where f is the frequency of the field, c is the speed of light, and l is a characteristic dimension of the measurement geometry, e.g. the distance between the field source and the measurement point

Note 1 to entry: Power frequency magnetic and electric fields near power lines and appliances are examples of quasi-static fields.

3.3.4

resultant field

field given by the expression

$$F_R = \sqrt{F_x^2 + F_y^2 + F_z^2} \quad (3)$$

where F_x , F_y , and F_z are the rms values of the three orthogonal field components,

or by the expression

$$F_R = \sqrt{F_{\max}^2 + F_{\min}^2} \quad (4)$$

where F_{\max} and F_{\min} are the rms values of the semi-major and semi-minor axes of the field ellipse, respectively.

Note 1 to entry: The resultant F_R is always $\geq F_{\max}$. If the field is linearly polarized, $F_{\min} = 0$ and $F_R = F_{\max}$. If the field is circularly polarized, $F_{\max} = F_{\min}$ and $F_R \approx 1,41 F_{\max}$.

3.4 Measurements

3.4.1

correction factor

numerical factor by which the uncorrected result of a measurement is multiplied to compensate for a known error

Note 1 to entry: Since the known error cannot be determined perfectly, the compensation cannot be complete.

3.4.2

coverage factor

numerical factor used as a multiplier of the combined standard uncertainty in order to obtain an expanded uncertainty

Note 1 to entry: For a quantity z described by a normal distribution with expectation μ_z and standard deviation σ , the interval $\mu_z \pm k\sigma$ encompasses 68,27 %, 95,45 % and 99,73 % of the distribution for a coverage factor $k = 1, 2$ and 3, respectively.

3.4.3

scale factor

factor by which the instrument reading is multiplied to obtain its input quantity

3.4.4

standard uncertainty

uncertainty of the result of a measurement expressed as a standard deviation

3.4.5**uncertainty of calibration**

parameter, associated with the result of a calibration, that characterizes the dispersion of the values that could reasonably be attributed to the measurand

Note 1 to entry: Uncertainty of calibration generally comprises many components. Some of these components may be estimated on the basis of the statistical distribution of the results of series of measurements, and can be characterized by experimental standard deviations. Estimates of other components can be based on experience or other information.

4 Symbols

| | |
|----------------------|---|
| a | = radius of coil probe; radius of spherical electric field probe |
| $2a, 2b$ | = side dimensions of rectangular coil |
| \mathbf{B} | = magnetic flux density vector |
| B_0 | = amplitude of alternating magnetic field |
| B_R | = resultant magnetic field |
| B_z | = axial magnetic flux density |
| C | = stray capacitance of coil probe |
| d | = spacing of parallel plates; distance from electromagnetic field source; spacing of Helmholtz coils |
| \mathbf{D} | = electric displacement vector |
| E | = electric field strength |
| E_0 | = uniform electric field strength |
| F_{\max}, F_{\min} | = rms values of semi-major and semi-minor axes of field ellipse |
| I | = current to magnetic field coils |
| L | = inductance of coil probe |
| N | = number of turns of wire (magnetic field coil system) |
| Q | = induced charge |
| r | = distance between magnetic field source and measurement location; resistance of coil probe and leads |
| R | = approximate input impedance of detector circuit (magnetic field meter); radius of Helmholtz coils |
| S | = electrode surface area (electric field meter) |
| t | = time |
| T | = period of periodic signal |
| V | = voltage |
| Z | = impedance in current injection circuit |
| λ | = wave length |
| ϵ_0 | = permittivity of free space |
| μ_0 | = permeability of free space |
| φ | = magnetic flux |
| ω | = angular frequency of alternating field |

5 Instrumentation specifications

5.1 General

When measuring field in the context of assessment of human exposure, the following items are considered below:

- measurement of the resultant field strength;
- measurement of the unperturbed electric field.

NOTE 1 Other items may be required depending on the goal of the measurement.

The various types of instrumentation available for characterizing quasi-static magnetic fields are described in Clause D.1.

The various types of instrumentation available for characterizing static magnetic fields are described in Clause D.3

Several types of magnetic field meters are in common use, e.g. field meters with coil probes, meters with Hall-effect probes, and meters that combine two coils with a ferromagnetic core as in a fluxgate magnetometer.

NOTE 2 Hall effect probes respond to static as well as time-varying magnetic flux densities. Due to limited sensitivity and saturation problems sometimes encountered when attempting to measure small power frequency flux densities in the presence of the substantial static geomagnetic flux of the earth, Hall-effect probes have seldom been used to measure magnetic fields of a.c. power lines.

The various types of instrumentation available for characterizing quasi-static electric fields are described in Clause E.1. The following two types of electric field meters are considered in this standard:

- a) the free-body meter;
- b) the ground reference meter.

Sufficient information shall be provided with the instrumentation, including instrument specifications and a clearly written instruction manual, to enable users to determine compliance with this standard, to aid them in the proper operation of the field meter, and to assess the usefulness of the device for the user's application. The instrument specifications that shall be provided and/or satisfied are given below.

5.2 Measurement uncertainty

The measurement uncertainty of the measuring instrument shall be specified by the manufacturer of the instrument. The measurement uncertainty shall be determined following the ISO/IEC Guide 98-3. The uncertainty shall be specified as an extended measurement uncertainty using a coverage factor of 2. The uncertainty is valid after available correction factors are applied. The uncertainty shall contain all components which are relevant when the instrument is used in a nearly uniform field. Such components may be calibration uncertainty, frequency response, deviations of the gain in different measurement range settings, isotropy of the probe, internal noise sources, non-linearity, stability, temperature response and humidity response. The uncertainty of the instrument does not include effects due to the handling of the instrument like positioning the probe in a non-uniform field or the influence of the measuring person on the field to be measured. Such components must be taken into account as additional uncertainties in the measurement report.

NOTE 1 At power frequency, the uncertainty of measuring instrument is usually 10 % or better.

NOTE 2 Examples of guidelines on the treatment of calibration uncertainties are given in Annex B.

5.3 Magnitude range

The magnitude range over which the instrument operates within the specified uncertainty shall be clearly indicated.

5.4 Pass-band

Broadband measuring instruments in the AC range always have a lower and an upper cut off frequency, which define a pass band. Normally the pass band limits are defined by the minus 3 dB point of the frequency response. The nominal frequency response of an instrument can be described as the frequency response of a system with a high pass filter and a low pass filter connected in series. The filter types and the filter orders should be specified (e.g. 3rd order Butterworth high pass and 5th order Butterworth low pass). The nominal frequency response of the instrument is normally not treated as a source of measurement uncertainty because the band limiting effect of the filters is a desired property of the instrument if broadband measurements are made. In frequency selective measurements (e.g. FFT) the band limiting effect of the filters is not desired and the nominal frequency response should be automatically corrected. The measurement uncertainty of an instrument due to manufacturing tolerances is normally greater at the band limits compared to medium frequencies. Therefore the measurement uncertainty of an instrument is often specified also and sometimes only in a restricted frequency range. This range is not as broad as the pass band but should be still broad enough to cover all frequencies of interest. In the restricted frequency range the influence of the nominal frequency response shall be negligible.

5.5 Operating temperature and humidity ranges

The temperature and relative humidity ranges over which the instrument operates within the specified uncertainty shall be at least -10 °C to 45 °C and 5 % to 95 %, respectively. Sudden temperature changes that can lead to condensation in the instrument should be avoided.

Electric field measurement may be perturbed if the relative humidity is more than 70 % due to condensation effect on the probe and support [2]¹. Since the effect of humidity depends on the field meter, the ability of the field meter to work correctly under those conditions should be checked before measurement (see Annex F).

5.6 Power supplies

The use of measurement equipment that is operating on internal battery power is recommended.

If batteries are used, provision should be made to indicate whether the battery condition is adequate for proper operation of the field meter. Instruments used to record personal exposure should be capable of at least 8 h operation within their rated uncertainty before replacement or recharging of the batteries becomes necessary.

If rechargeable batteries are used it is recommended that the instrumentation is not operated while connected to the charging station. When such connections are necessary, it should be demonstrated that stray fields from the battery charger, conducted disturbances from the mains voltage and electromagnetic coupling via the connecting leads (to the battery charger) do not affect the measurement (see 5.9).

There shall be no wire connections to electric field free-body meters.

If batteries with ferromagnetic jackets are used in exposure meters, care must be exercised that the jackets do not significantly influence readings by the instrument (see IEC 61786-2 for more details about source of measurement uncertainty).

¹ Numbers in square brackets refer to the Bibliography.

5.7 Readability of scale

The display of the meter, if applicable, should be digital.

Remote displays shall be used to avoid perturbation of the electric field by the observer.

The meter digital displays of magnetic field survey meters should be large enough to be easily read at arm's length. If more than one range of sensitivity is provided, the full scale value of the selected range should be indicated, and the units should be readily interpretable. For auto-ranging instrumentation, the magnitude range may be indicated elsewhere, e.g. in the user manual. The instrumentation should provide a clear indication of the units being displayed.

5.8 Instrument dimensions and choice of probe

5.8.1 General schema

A general schema of a meter is given in Figure 1.

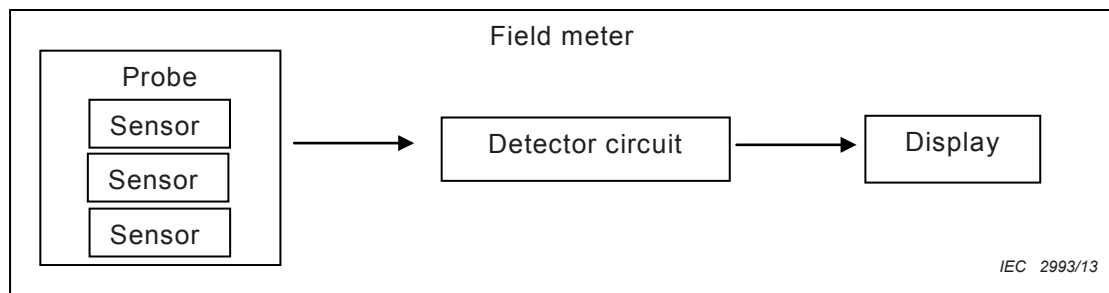

Figure 1 – Schema of a field meter

The probes should be three-axis.

NOTE Single-axis probes can be used to measure the rms values of the semi-major axes of the field ellipse by orienting the probe until a maximum reading is obtained. Single-axis meters can also be used to determine the resultant magnetic field by measuring the rms values of three orthogonal spatial components and combining them according to Equation (3). It is assumed that during this procedure there are no significant changes in the rms values of the spatial components. Single axis use is suitable for electric field measurement referenced to conducting surface.

5.8.2 Magnetic field meter

The dimensions of the meter should be provided.

The size of the probe should be appropriate to the spatial variation of the field measured. The probe shall be of area 0,01 m², or smaller. With three-axis probes, the three sensors may be concentric or, if the sensors are no larger than 0,05 m, they should be as close together as possible. The maximum dimension of the space containing the three sensors combined shall not exceed 0,2 m.

Coil probes should be either circular or square in cross-section; small deviations from these shapes, for example where concentric coils cross each other, are permitted.

Since the induced voltage is proportional to the time derivative of the magnetic flux density, the detector circuit requires an integrating stage to recover the waveform of the magnetic flux density.

The locations and orientations of the sensors that are contained within the housings of magnetic field meters shall be clearly indicated on the instrument or in the instruction manual.

5.8.3 Electric field meter

The dimensions for electric field meters should be given in the manufacturer documentation according to meter type:

- a) free-body meter: the maximum probe dimensions of the volume containing probe shall not exceed 0,2 m;
- b) ground reference meter: probe dimensions and length of connecting coaxial cable.

5.8.4 Support for electric field meter

The support for electric field meter shall be made of insulating material, such as synthetic or composite material.

The dimension of the support depends on how the probe is supported:

- probe supported by a insulating tripod = 1m (Figure 2);
- probe supported by a standing man holding a hand-held stick = 2m (Figure 3).



IEC 2994/13

Figure 2 – Insulating tripod and offset rod for an electric field probe (photograph RTE)



IEC 2995/13

Figure 3 – Electric field measurement using a hand-held stick (photograph RTE)

5.9 Electromagnetic compatibility

5.9.1 Immunity

- a) Power frequency electric field

Instrumentation intended for use in the vicinity of high-voltage equipment operating at power frequencies shall not be affected significantly by ambient electric fields as large as 20 kV/m, i.e. the influence of the electric field on the magnetic field reading shall be less than 0,2 μ T. This immunity requirement may need to be increased for some extreme environments where electric fields as large as 100 kV/m may exist, e.g. near high-voltage transmission line conductors.

Tests for immunity to power frequency electric fields may be performed using the parallel plates systems described in Clause A.2.

NOTE 1 The proximity effect of the instrument user can shield or enhance the electric field, depending on the geometry of the field and the location of the magnetic field meter relative to the user. For influence of user during electric field test, see IEC 61786-2

b) Power frequency magnetic field

Instrumentation intended for use in the vicinity of high-voltage equipment operating at power frequencies shall not be affected significantly by ambient magnetic fields as large as 1 mT, i.e. the influence of the magnetic field on the electric field reading shall be less than 10 V/m. Instrumentation shall be tested in accordance with the methods described in IEC 61000-4-8.

Tests for immunity to power frequency magnetic fields may be performed using the coil systems described in Clause A.1.

c) Radiated electromagnetic fields

The operation of instrumentation shall not be affected by electromagnetic radiation for frequencies defined in IEC 61000-4-3 for an electric field of 3 V/m rms for frequencies between 80 MHz and 2 GHz, and 1 V/m rms for higher frequencies.

Testing of instrumentation shall be in accord with the methods described in IEC 61000-4-3.

NOTE 2 In IEC 61000-4-3:2006+A2:2010 the frequency range is 80 MHz-6 GHz, intended to cover radiofrequency applications as broadcasting, radiocommunication, GSM, Wifi, etc.

The operation of instrumentation shall not be affected by electromagnetic radiation between 150 kHz and 80 MHz. Tests shall be conducted according to the methods described in IEC 61000-4-6 at a voltage level of 3 V rms. The instrumentation shall continue to operate normally during both of the above tests.

Battery-powered equipment (dimension $< \lambda/4$) which has no connection(s) to the ground nor to any other (non-insulated) equipment, and which will not be used during battery charging, does not need to be tested according to IEC 61000-4-6.

NOTE 3 The immunity requirements may need to be increased under certain conditions, e.g. during measurements near radio-broadcasting antennas and mobile telephones.

d) Immunity to transients

Specifications for instrumentation connected to the mains in order to carry out measurements shall also be tested at the a.c. power port (interface of field meter with external power source or AC wall outlet) for compliance with IEC 61000-4-4 (electrical fast transient) for a peak voltage of 2 kV. A temporary degradation of performance during the test which is self-recoverable is acceptable.

e) Electrostatic discharge (ESD)

During most measurement applications, electrostatic discharges to or from the instrumentation are not anticipated. However, the connectors of the instrumentation shall be immune to a contact or discharge voltage of at least 2 kV and tested in accordance with the methods described in IEC 61000-4-2. No degradation of performance shall occur.

5.9.2 Emissions

a) Harmonic emissions

The harmonic emissions of instrumentation with a power rating of 50 W or greater shall be restricted according to the requirements of IEC 61000-3-2 class A.

NOTE Battery operated equipment is considered to meet the requirements.

- b) Conducted disturbances – 0,15 MHz to 30 MHz (instrumentation connected to AC power supply)

The conducted disturbances shall be less than the limits defined in Table 1 as a function of frequency (see CISPR 11, Table 3.).

Table 1 – Mains terminal disturbance voltage limits for class B group 1 equipment measured on a test site

| Frequency band MHz | Quasi-peak dB(μ V) | Average dB(μ V) |
|---|---|---|
| 0,15 – 0,50 | 66 Decreasing linearly with logarithm of frequency to 56 | 56 Decreasing linearly with logarithm of frequency to 46 |
| 0,50 – 5 | 56 | 46 |
| 5 – 30 | 60 | 50 |
| At the transition frequency, the more stringent limit shall apply | | |

Testing of instrumentation shall be in accordance with the methods described in CISPR 11.

- c) Radiated disturbances – 30 MHz to 1 000 MHz

The electromagnetic emissions from instrumentation containing devices operating at frequencies of 9 kHz or higher shall be limited to the values listed below (see CISPR 11, Table 5, electromagnetic radiation disturbance limits for class B group 1 equipment measured on a test site at 10 m).

Quasi-peak: 30 dB (μ V/m) at 10 m (30 MHz to 230 MHz)

Quasi-peak: 37 dB (μ V/m) at 10 m (230 MHz to 1 000 MHz)

Testing of instrumentation shall be in accordance with the methods described in CISPR 11.

5.10 Crest factor

The measuring system shall measure correctly the true rms value of the field, even when the crest factor of the magnetic field is 3.

NOTE Many practical fields exhibit a large crest factor and the presence of a large crest factor may lead to unwanted saturation in the amplifier stages of the detector.

5.11 Durability

The indicating meter and other system components shall be rugged enough to withstand vibration and shock resulting from transport. A carrying case is desirable. The instrumentation shall be compliant with IEC 60721-3: storage class 1M2, transport class 2M3 and operation class 7M3.

5.12 Weight

The weight of the instrumentation should be provided. The weight of portable instrumentation should be kept as low as is practical to permit hand-held operation under restrictive conditions, e.g. in some industrial environments.

The weight of free-body electric field meters should be kept as low as is practical so that it can be held conveniently by hand with an insulating perch as long as 2 m.

5.13 Instrumentation choice

The choice of the measuring instrument should be made as a function of measurement procedures, especially concerning the need of information in the measurement report

Appropriate measuring instrument should be chosen in function of the field characteristics.

6 Calibration

6.1 General

Measurement systems are required to undergo calibration throughout their service life. All calibrations shall be traceable to national and international standards through an unbroken chain of calibrations, all having stated uncertainties.

The following three methods of magnetic field calibration are covered by this standard:

- a) calibration by introduction of the field meter probe into a calculable magnetic field (following measurements of coil dimensions and current to the coil system);
- b) calibration using a voltage injection technique;
- c) calibration by comparison with a reference measurement system.

The first method is the most used and is detailed in 6.2.2. The other two methods are detailed in Annex A.

The following method of electric field calibration is covered by this standard:

- calibration by introduction of the field meter probe into a calculable electric field (parallel plates system).

6.2 Calibration procedure

6.2.1 General

The procedures of this section should be followed, as appropriate, in all cases.

Calibration shall be performed at regular intervals. The initial interval should be of twelve months. This interval may be altered depending on the drift of the field meter response between calibrations and also depending on the conditions of use.

6.2.2 Magnetic field calibration system

For calibration of the higher magnitude ranges (i.e. ranges not significantly influenced by background magnetic fields), the magnetic field probe shall be placed in a nearly uniform field produced by a coil system (see Clause A.1). Each sensor axis, in turn, shall coincide with the axis of the coil system and the largest departure of the field from the central value shall be less than 1 % over the cross-sectional area of the probe.

Information on fields generated by rectangular, square, and circular loop systems (including Helmholtz coils) is given in [7], [18], [28], [34] and A.1. For example, the magnetic flux density produced by a single square loop (of many turns of wire) 1 m × 1 m will satisfy the uniformity requirement for a probe with a 0,10 m diameter (see Clause A.1). The loop size may be scaled upwards or downwards for larger or smaller probes, respectively, to maintain the indicated level of uniformity across the probe. The calibration may also be performed using the voltage injection technique or by comparison with a reference magnetic field meter (see Clause A.1).

The field uniformity requirement during calibration may be relaxed for large probes that are used for determining average values of non-uniform fields and, or for applications where spatial resolution requirements are not considered important. In this case, the largest departure of the calibration field from the central value should be $\leq 1,5$ % over the cross-sectional area of the probe. For example, the field produced by a square loop $1,3 \text{ m} \times 1,3 \text{ m}$ will satisfy this uniformity requirement for a probe with a $0,20 \text{ m}$ diameter.

Calibrations of each axis of three-axis field meters shall be performed with sinusoidal magnetic fields or their equivalent voltages (voltage injection technique) at the levels and frequencies indicated by the instrument specifications. The current to the calibration coils shall be nearly free (total harmonic distortion < 1 %) of harmonic content.

6.2.3 Electric field calibration system

During calibration, the field meter probe shall be placed in a nearly uniform field produced with parallel plates according to meter type, as described in Clause A.2. The departure of the field at the centre of the parallel plates from the uniform field value, i.e. the field produced by infinite parallel plates, shall be less than 1 % (see Clause A.2). The parallel plate spacing shall be sufficient to avoid proximity effects when the field meter probe is introduced between the plates (see Clause A.2). For example, free-body meters with no diagonal dimension greater than $0,23 \text{ m}$ may be calibrated at the centre of parallel plates $1,5 \text{ m} \times 1,5 \text{ m} \times 0,75 \text{ m}$ spacing. The parallel plate dimensions may be scaled upward or downward for larger or smaller free-body meters. Each sensor axis, in turn, shall coincide with the direction of the electric field.

NOTE It is possible to calibrate the probe fixed on the support usually used for measurements, but not on the 3 axes of the probe (in this case, the dimension on the plates needs to be 2 m high and horizontal) – the other solution is to calibrate the probe alone on the 3 axes

Calibration of single-axis field meters and each axis of the three-axis field meters shall be performed with sinusoidal electric fields at the levels and frequencies indicated by the instrument specifications.

Energizing power supplies for the parallel-plates should provide voltages which are nearly free (total harmonic distortion ≤ 2 %) of harmonic content. Where this is not possible, the harmonic content should be recorded and it should be demonstrated that the harmonic content makes a negligible difference to the results of the calibration.

6.2.4 Three-axis probes calibration

When calibrating each axis of three-axis probes, checks for the isotropy of the probes as well as for crosstalk between the detector circuitry for each sensor shall be made. The three-axis probe and field should be configured so that the axis of each sensor can be aligned with the field direction in succession. For each alignment of the sensor, the output from the remaining two sensors should be measured and should be less than 3 % of the signal from the aligned sensor.

NOTE 1 The calibration of field meters with three-axis probes can also be checked for one orientation (at one frequency and field level) where approximately the same flux passes through all the coils.

NOTE 2 For three-axis instrumentations which are only giving the resultant of the field, this can be achieved by putting the instrument along the three axes and checking the resultant output.

6.2.5 Calibration values

At least three field levels for each measurement range of the field meter, between 30 % to 90 % of the full scale, should be recorded for meters with analogue displays. At least one point, between 10 % to 90 % of the full scale, should be obtained with field meters with digital displays.

For testing the different measurements ranges, the injection method may be needed.

Field meters with auto-ranging capabilities should be calibrated on each range at no less than one representative points inside the range.

For one field level, calibrations should be performed at three frequencies which span the pass-band, i.e. at the highest and lowest frequencies, and one intermediate frequency.

During calibration, the signal to noise ratio shall be high enough. If not, this shall be taken into account in the calibration uncertainty.

The resonant frequency of the calibration loop should be substantially greater than the calibration frequencies so that calibrations are not affected by the resonance phenomenon (see Clause A.1).

Perturbations of the calibration field due to image currents in nearby ground planes and proximity effects of ferromagnetic materials shall be made negligible (see Clause A.1).

6.2.6 Calibration uncertainty

The calibration uncertainty shall be determined following the ISO/IEC Guide 98-3.

The field in the calibration system shall be known with an uncertainty of less than $\pm 3\%$ (coverage factor 1).

For a magnetic field, the magnitude may be determined by calculation based on measurements of the coil dimensions, the number of turns in the coil(s) and the current in the coils (see Clause A.1), or by direct measurement with a calibrated reference magnetic flux density meter with sufficiently low measurement uncertainty. If the voltage injection technique is used as part of the calibration (see Clause A.1), the equivalent magnetic flux density is determined by the injected voltage.

For an electric field, the magnitude may be determined by calculation based on measurements of the parallel plate spacing and voltage (see Clause A.2), or by direct measurement with a calibrated reference electric field strength meter with a sufficiently low measurement uncertainty.

The uncertainty of the calibration will be determined by such factors as the uncertainty in the value of the field value in the calibration system ($\pm 3\%$) or the uncertainty in the injected voltage, the resolution in the reading of the instrument under test, and the variation of the reading if the instrument under test is repeatedly placed into the calibration system. Other factors such as ambient background magnetic fields may further compromise the uncertainty of the calibration. The overall uncertainty of the calibration process (coverage factor 1) shall be no greater than $\pm (5\% + 10 \text{ nT or } 1 \text{ V/m})$. A coverage factor of 2 shall be used when specifying expanded measurement uncertainty, i.e. the expanded measurement uncertainty would be in this case $\leq \pm (10\% + 20 \text{ nT or } 2 \text{ V/m})$. The calibration shall be traceable to national and/or international standards. Guidelines on the treatment of all uncertainties and a listing of the sources of uncertainty are given in 5.2 and an example is given in Annex B, respectively.

6.3 Calibration documentation

The following items should be addressed when preparing the calibration certificate, in addition to the data for the instrument specifications (see 5.2 to 5.12). Each calibration certificate shall include at least the following information, unless the laboratory has valid reasons for not doing so:

- a title (e.g. “Calibration Certificate”);
- the name and address of the laboratory, and the location where the calibrations were carried out, if different from the address of the laboratory;

- unique identification of the calibration certificate (such as the serial number), and on each page an identification in order to ensure that the page is recognized as a part of the calibration certificate and a clear identification of the end of the certificate;
- the name and address of the client;
- identification of the method or standard used;
- a description of, the condition of, and unambiguous identification of the item(s) calibrated;
- the date of receipt of the calibration item(s) where this is critical to the validity and application of the results, and the date(s) of performance of the calibration.
- reference to the procedures used by the laboratory where these are relevant to the validity or application of the results.
- the calibration results with, where appropriate, the units of measurement;
- the name(s), function(s) and signature(s) or equivalent identification of person(s) authorizing the calibration certificate.

Instrument manufacturers should also document their calibration procedures, indicating all of the following information as may be applicable:

- magnetic field coil geometry and dimensions;
- resonance frequency of coil system;
- instrumentation for measurement of current to coil system; instrumental uncertainty; date of last calibration;
- instrumentation used for voltage measurement (voltage injection technique, see Clause A.1); instrumental uncertainty; date of last calibration;
- voltage divider ratio (voltage injection technique, see Clause A.1); dependence of ratio on frequency; uncertainty in ratio value;
- parallel plate dimensions and separation;
- instrumentation for the measurement of voltage to parallel plates; instrumental uncertainty; date of last calibration;
- uncertainty of reference measurement system; probe dimensions; pass-band; date of last calibration.

This information should be made available to clients upon request. Testing laboratories should also comply with the above requirements, as applicable.

Note Further guidelines on the calibration certificate can be found in 5.10 of ISO/IEC 17025:2005 [36].

7 Verification

The verification is a simple procedure to check the functionality of the field meter that should be done before using the meter. It includes:

- state of the battery;
- required accessories;
- visual inspection;
- calibration date.

Annex A (normative)

Calibration methods

A.1 Calibration of magnetic flux density meters

A.1.1 Using magnetic field generation

Calibration of a magnetic field meter is normally done by introducing the probe into a nearly uniform magnetic field of known magnitude and direction. Known magnetic fields may be produced using coil systems with circular and rectangular geometries [1], [7], [18], [25], [34]. For example, Helmholtz coils have frequently been employed to generate such fields. Comparison of field uniformity for fields produced by single square and circular coils, and square and circular Helmholtz coils are shown in Figure A.1 [7]. Figure A.1 shows the deviation of the axial magnetic field, in percentage, as a function of normalized distance from the axis of each coil system, where the distance is along a Cartesian coordinate (see Figure A.2 for the case of the single square loop). The distance is given as a percentage of the radius for the circular coils and as a percentage of half the side dimension for the square coils.

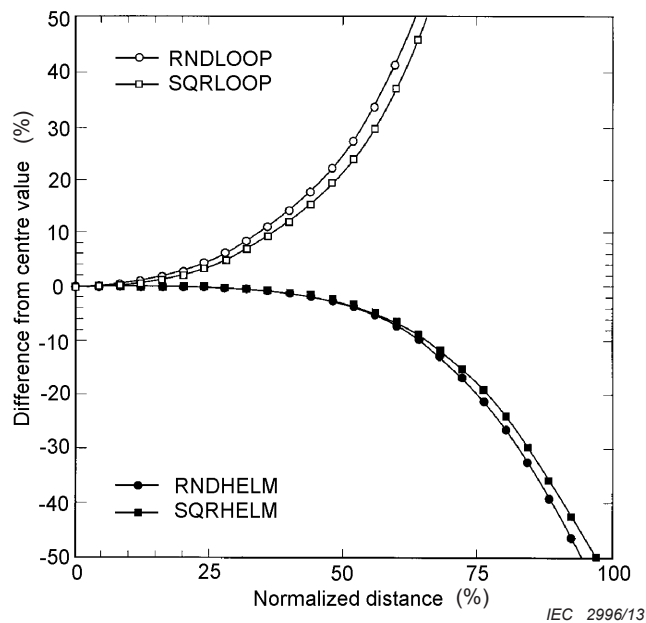

Figure A.1 – Deviation in percentage departure of calculated axial field [7]

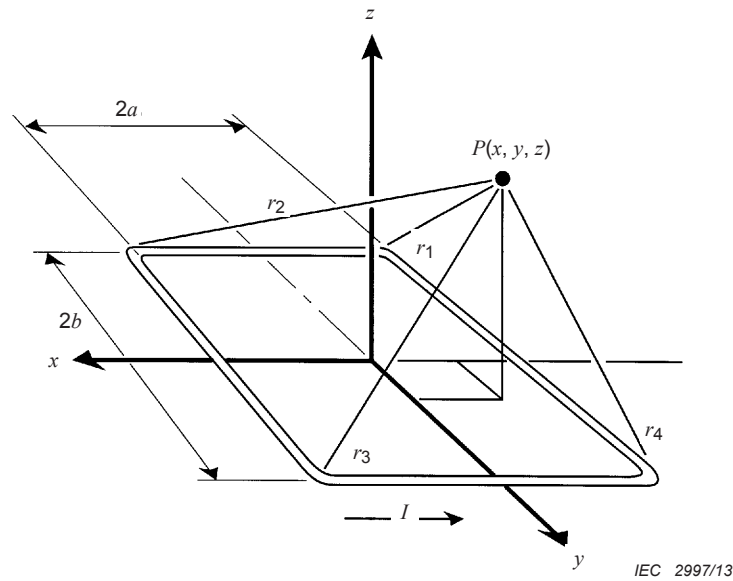

Figure A.2 – Coordinate system and geometry of rectangular loop of many turns of wire (see Equation (A. 1))

A single loop of many turns of wire with rectangular geometry used to produce the field is described below because the equations for calculating the field at all points in space are in closed form [19],[34] and the coil system is simple to construct. The simplicity of construction is at the expense of reduced field uniformity, but a sufficient uniformity for calibration purposes is readily obtained.

The z-component of the magnetic flux density, produced by a rectangular loop $2a \times 2b$ at a point in space $P(x,y,z)$, is given by the expression [19],[34]

$$B_z = \frac{\mu_0 IN}{4\pi} \sum_{\alpha=1}^4 \left[\frac{(-1)^\alpha d_\alpha}{r_\alpha [r_\alpha + (-1)^{\alpha+1} C_\alpha]} - \frac{C_\alpha}{r_\alpha (r_\alpha + d_\alpha)} \right] \quad (\text{A.1})$$

where

N is the number of turns;

$$C_1 = -C_4 = a + x;$$

$$C_2 = -C_3 = a - x;$$

$$d_1 = d_2 = b + y;$$

$$d_3 = d_4 = y - b;$$

$$r_1 = [(a + x)^2 + (b + y)^2 + z^2]^{1/2};$$

$$r_2 = [(a - x)^2 + (b + y)^2 + z^2]^{1/2};$$

$$r_3 = [(a - x)^2 + (b - y)^2 + z^2]^{1/2};$$

$$r_4 = [(a + x)^2 + (b - y)^2 + z^2]^{1/2};$$

I is the rms current in amperes;

μ_0 is the permeability of the air;

x , y , and z are the coordinates shown in Figure A.2.

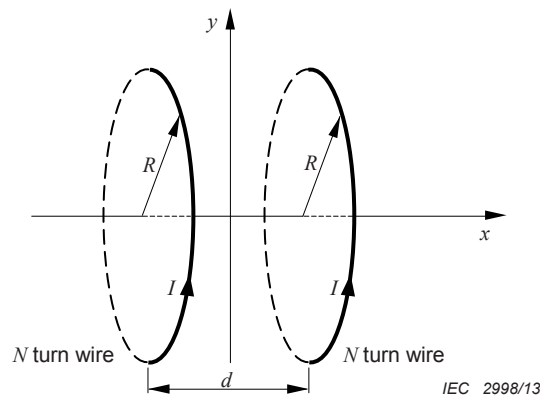

Figure A.3 – Circular Helmholtz coils

The magnetic field on the axis of circular Helmholtz coils of radius R is given by

$$B = \frac{\mu_0 NI}{2R} \left(1 + \frac{\left(x + \frac{d}{2} \right)^2}{R^2} \right)^{-\frac{3}{2}} + \frac{\mu_0 NI}{2R} \left(1 + \frac{\left(x - \frac{d}{2} \right)^2}{R^2} \right)^{-\frac{3}{2}} \quad (\text{A.2})$$

N = number of turn

I = current

For $R = d$ and $x = 0$,

$$B = \frac{8\mu_0 NI}{5^{\frac{3}{2}} R} \quad (\text{A.3})$$

The derivation of Equation (A.1) assumes that the conductors in the current loop have negligible cross-sections. It is noted for reference purposes that

$$B_z = \frac{\mu_0 IN\sqrt{2}}{\pi a} \quad (\text{A.4})$$

at the centre of a square loop of side dimension $2a$. Equation (A.1) has been used to calculate the field values at and near the centre of a square loop of dimensions $1 \text{ m} \times 1 \text{ m}$. The percentage departure from the central magnetic field value at nearby points in the plane of the loop and at $0,03 \text{ m}$ above and below the plane of the loop (in parentheses) are plotted in Figure A.4. Also shown in Figure A.4 is a scale drawing of a magnetic field probe $0,10 \text{ m}$ in diameter. The departure of the magnetic field from the central value over the cross-sectional area of the $0,10 \text{ m}$ probe is less than 1% . Figure A.5 shows a schematic view of the probe, square calibration loop, and associated circuit for energizing the coils.

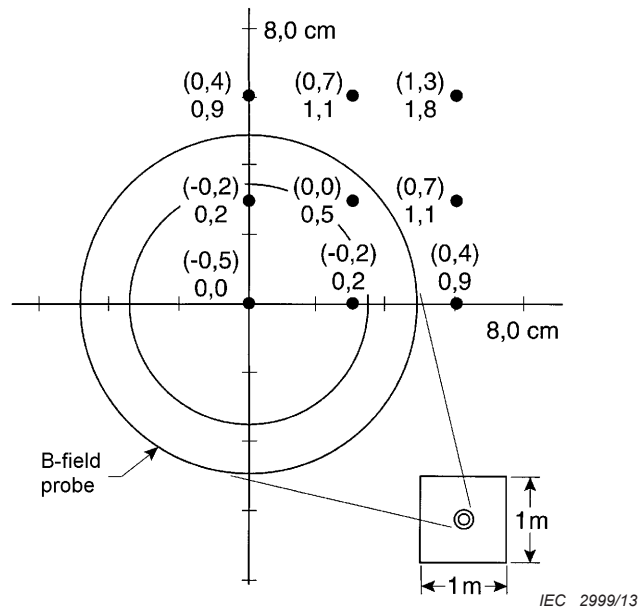

A scale drawing of a coil-type probe of 0,10 m in diameter is outlined.

Figure A.4 – Deviation in percentage of calculated B_z from centre value (see Equation (A.4))

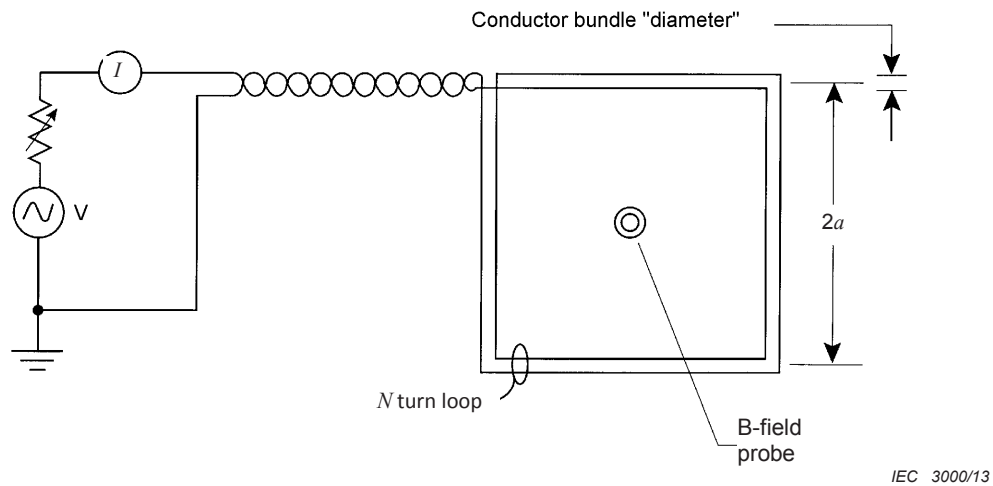

Figure A.5 – Schematic view of a circuit for calibration of magnetic field meter using a square loop to produce a known field

NOTE The uncertainty (coverage factor 1) in the value of the calibration field is determined by the uncertainties associated with calculating B_z . For example, in the case of a 1 m × 1 m square loop (see figures A.4 and A.5), the uncertainty is due to uncertainties in the measured current I , the side dimension of the loop, and the effect of non-uniformity of the magnetic field (< 0,5 % for a 0,10 m diameter probe). The uncertainty in the side dimension of the square loop can be due to a non-negligible conductor bundle cross-section. The side dimension may be taken to be the distance between the centres of the conductor bundles with an uncertainty equal to ± the conductor bundle "diameter" (see Figure A.5). The combined uncertainty in the value of the magnetic flux density is given by the square root of the sum-of-the-squares. If, for example, uncertainties in the determination of I and side dimension are ± 0,2 % and ± 1,0 %, respectively, the combined uncertainty in the value of the calibration field for the 0,10 m diameter probe is ± [(0,2)² + (1,0)² + (0,5)²]^{1/2} or ± 1,1 % (coverage factor 1).

It is noteworthy that a field meter with a coil probe will indicate a magnetic field value that is an average over the cross-sectional area of the probe. The difference between this average and the central value [see Equation (A.4)] will be less than the maximum percentage departure from the central value. For example, while the largest departure of the magnetic

field from the central value is 0,63 % for the 0,10 m probe (in the plane of the loop), the average field is only 0,31 % more than the central (calibration field) value.

The equation for magnetic fields produced by two square coils can be derived using Equation (A.1) and the principle of superposition [24]. The necessary condition for square Helmholtz coils is that the spacing between the coils is equal to $0,5445 \times 2a$, where $2a$ is the side dimension of the coil system [6].

By varying the frequency of the current through the loop, the frequency response of the field meter may be determined for the frequency range of interest. For a suitably designed detector with a stage of integration, a field meter with an air core probe should indicate a nearly constant rms value as the frequency is varied (see Clause A.1, last paragraph for discussion of resonance frequency effects of calibration coil). A similar result should be obtained with a coil probe that has a core of soft ferromagnetic material, if the change in permeability as a function of frequency is negligible.

Calibration of the higher scales of a magnetic field meter, i.e. $> 10 \mu\text{T}$, can usually be performed with a field generated by a coil system because background fields that are typically $0,1 \mu\text{T}$ or less make a negligible contribution to the calibration field. However, the presence of background fields can prevent calibration of the more sensitive scales because of their perturbing effects on the calibration field. An alternative procedure for calibrating the sensitive scales is to use the voltage injection technique [8].

A.1.2 Voltage injection method

The voltage injection technique may also be useful for calibrating the very high ranges of field meters, e.g. ranges greater than 10 mT, when there may be technical difficulties in generating such fields with a coil system.

NOTE Because of constraints introduced by instrument design, the voltage injection calibration method may only be applicable during the design stage or manufacturing stage of the field meter.

Using this procedure, the volts/tesla produced by a coil probe (when connected to the detector circuit) can be determined at each frequency of interest, using a voltmeter connected to the input of the detector and a magnetic field that is at least two orders of magnitude larger than the background field. Voltages that correspond to smaller magnetic fields are then injected into the detector circuit (with the probe disconnected) to calibrate the more sensitive scales of the magnetic field meter. A voltage divider with a well-known ratio when connected to the detector, an a.c. voltage source (e.g. a function generator), an accurate voltmeter, and adequate electric field shielding can be used to inject the known voltages for the frequency range of interest [8]. The frequency dependence of the voltage divider ratio should also be known in order to carry out the calibration. Figure A.6 shows a schematic view of a voltage injection circuit connected to the detector.

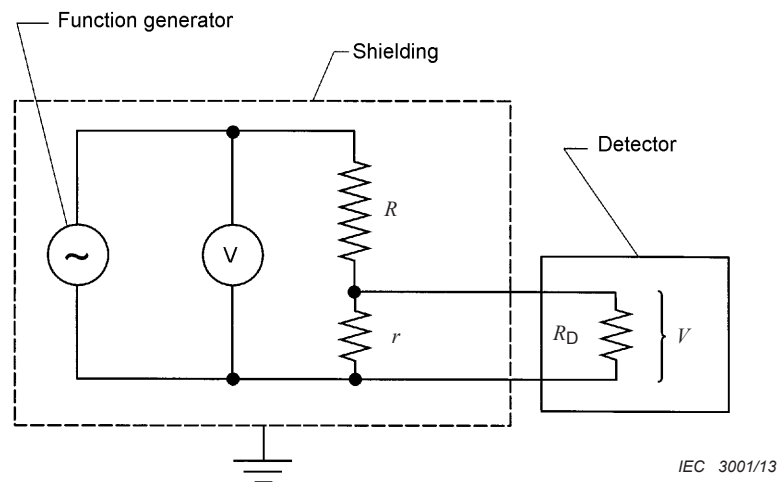

The voltage V from a function generator is reduced for injection purposes using a resistive divider. The injected voltage v is given by $Vr/(R+r)$ in the absence of frequency effects on the divider ratio. R and r are resistors with R typically much larger than r . The input impedance of the detector is approximated as a resistance R_D . The relation $r \ll R_D$ shall be satisfied to avoid significantly affecting the value of the divider ratio.

Figure A.6 – Diagram for voltage injection technique

The voltage injection approach may not be applicable to probes with ferromagnetic cores because the permeability of the core may vary with the magnetic flux density and affect the probe sensitivity (volts/tesla). It should be noted that the voltage injection technique can also be used as a means of verifying the calibration of all ranges of the magnetic field meter.

A.1.3 Comparison with reference magnetic field meter

A third method for calibrating instrumentation is performed by comparing field meter readings with a reference magnetic field meter that has previously been calibrated in a known magnetic field and/or by the voltage injection technique. With this approach, the field values determined with each sensor of the single-axis and three-axis field meters are compared with measurements obtained with the reference field meter in the same magnetic field (produced by a coil system). It is assumed that (1) the sensor dimensions of the meter being calibrated and the reference meter are comparable, or the field uniformity is sufficiently great that the averaging effects of the sensors (over their cross-sectional areas) are not significantly different, (2) the pass-band of the field meter being calibrated is comparable to that of the reference meter, and (3) background magnetic fields (typically unstable) do not make significant contributions to the calibration field. Comparisons are made at field levels and frequencies of interest.

Alternatively, the reference magnetic field meter may be used to verify the calibration of a coil system used for calibration purposes.

NOTE 1 Comparison of the magnetic field meter readings with the calibration field values enables the determination of correction factors that should be applied to readings when measurements are performed. Alternatively, the comparisons allow corrective adjustments to be made in the detector circuit. In either case, the uncertainty associated with the above calibration processes is equal to the uncertainty in the value of the calibration field values (once the corrections have been made) combined with uncertainties related to the stability and resolution of the field meter readings.

Perturbations of the calibration field can be produced by image current loops in nearby ground planes. For example, when the plane of a square loop is parallel to a *perfect* ground plane, the perturbation of the field at the centre of the loop is 2 % and 0,3 % for distances of one and two loop-side dimensions, respectively. The perturbation is reduced when the plane of the loop is perpendicular to the ground plane, e.g. the perturbation for the square loop is 0,3 % when the side of the loop is one side dimension away from the ground plane. Perturbation of the calibration field is less for square Helmholtz coils [7].

Perturbations of the calibration field can also occur because of ferromagnetic materials in close proximity to the calibration loop. For example, large permeability materials, such as steel in a nearby cabinet or desk or a bracket under a table, will concentrate the magnetic flux and may perturb the value of the calculated field in the calibration loop. The influence of nearby ferromagnetic materials on the calibration field should be checked using a trial and error approach, e.g. the influence of a nearby relay rack on the magnetic field could be examined as a function of distance from the calibration coil.

Calibrations should be performed at frequencies well removed from the resonance frequency of the coil system. Because of the stray capacitance, the equivalent circuit of the coil system can be roughly modelled as an inductor and capacitor in parallel. Near and at resonance frequencies, significant amounts of current to the coils will be shunted through the stray capacitance and will not contribute to production of the magnetic field. One approach to determine the resonance frequency of a coil system is to measure the voltage across the coils as a function of frequency while keeping the current to the coils constant. At frequencies well removed from the resonance frequency, the voltage will increase linearly. Near the resonance frequency, the impedance of the coil system and the associated voltage measurement will become non-linear and increase more rapidly.

NOTE 2 A specific analysis will be necessary to determine an upper operating frequency limit for calibration coils.

A.2 Calibration of electric field strength meters

A.2.1 Electric field generation method

Nearly uniform electric fields may be produced for calibration purposes with parallel plates, provided that the dimensions of the plates are sufficiently large relative to the plate spacing, [1] [13], [32]. Ignoring edge effects, the uniform field value E_0 is given by V/d where V is the applied potential difference across the plates and d is the plate spacing. As a guide for determining parallel plate dimensions, the calculated magnitudes of the electric field strength E , normalized by the uniform field (E/E_0) at the plate surface and midway between the plates, are plotted as a function of normalized distance x/d from the plate edge as shown in Figure A.7. Numerical values are presented in Table A.1.

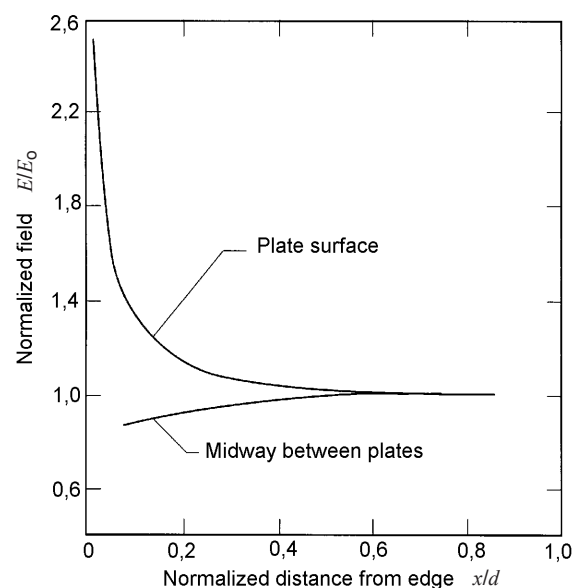

IEC 3002/13

Figure A.7 – Calculated normalized electric field at plate surfaces and midway between plates as a function of the normalized distance from the edge of the plate

The results in Table A.1 show that the departure from field uniformity due to fringing fields decreases to 0,1 % at a distance of one plate spacing from the edge. For square plates of finite size, the effect of the fringing fields from the four edges may be estimated using the principle of superposition when the effect from one edge is less than 0,1 %. Numerical calculations of the field between finite size parallel plates suggests a discrepancy of 0,04 % using this approach [32]. These results are valid in the absence of perturbations from nearby ground planes. Calculations and measurements [19] , [32] indicate that energization of the parallel plates with a centre-tapped transformer provides a field that is more immune to perturbations due to nearby ground planes.

A parallel plates system that has been proven suitable for calibrations of free-body meters with diagonal dimensions less than 0,23 m is shown in Figure A.8 [13]. Metal sheets or a tightly stretched metal screen on frames of 1,5 m × 1,5 m, and a separation of 0,75 m are used to form the parallel plates. The plates are energized with a function generator/power amplifier/transformer combination which has adequate current-limiting resistors in the transformer output leads as a safety measure [3]. For example, 10 MΩ and larger resistors of adequate voltage rating are satisfactory up to 10 kV (i.e. $E \approx 13$ kV/m). Normal high-voltage laboratory safety practices shall be followed when working with high voltages. A calibration field that is within 1 % of the uniform field value, V/d , is produced at the centre of the parallel plates system described above (uncertainties in the values of V and d should be combined with the 1 %). The free-body meter is positioned at the centre of the parallel plates system with the insulating handle normally used during measurements.

To avoid significant perturbations of the surface charge distributions on the parallel plates due to the presence of the field meter, the largest diagonal dimension of the meter should not be greater than 0,23 m [23]. In addition, the distance from the parallel plates to the nearest ground plane (walls, floor, etc.) should be one plate spacing or more. The parallel plates system may be scaled upwards or downwards for larger or smaller field meters.

NOTE If corona occurs at the edges of the parallel plates, it can be eliminated by attaching metal tubes along the edges to reduce the surface electric field strength.

By varying the frequency of the voltage to the parallel plates, the frequency response of the field meter may be determined.

Table A.1 – Calculated normalized electric field values midway between plates and at plate surfaces

| Midway between plates | |
|-----------------------|---------|
| x/d | E/E_0 |
| 0,069 8 | 0,837 |
| 0,162 1 | 0,894 |
| 0,296 5 | 0,949 |
| 0,417 7 | 0,975 |
| 0,682 1 | 0,995 |
| 0,793 4 | 0,997 |
| 1,000 0 | 0,999 |
| Plate surfaces | |
| 1,000 0 | 1,001 |
| 0,795 4 | 1,002 |
| 0,686 1 | 1,005 |
| 0,437 6 | 1,025 |
| 0,243 1 | 1,095 |
| 0,162 4 | 1,183 |
| 0,123 0 | 1,265 |
| 0,099 1 | 1,342 |
| 0,082 9 | 1,414 |
| 0,045 2 | 1,732 |
| 0,030 7 | 2,000 |
| 0,018 5 | 2,449 |

If the distance of the lower plate to the floor is less than one plate spacing, the arrangement designed to energize the parallel plates as shown in Figure A.8 may be modified so that the lower plate is at ground potential.

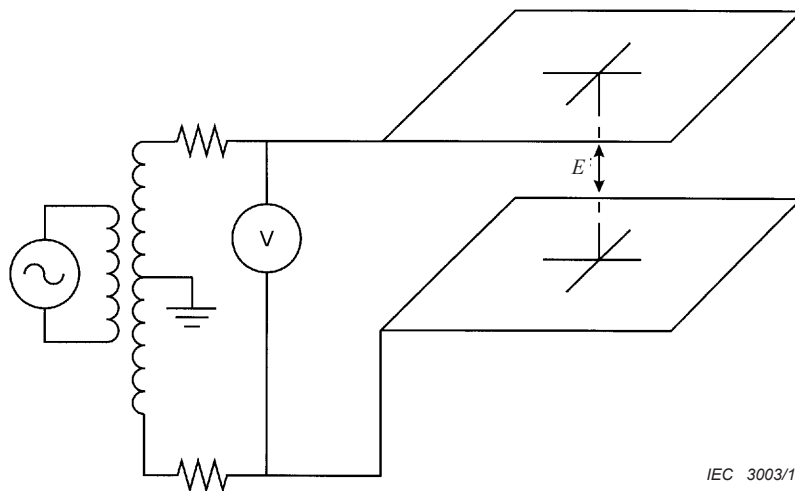

IEC 3003/13

Figure A.8 – Parallel plates system for calibrating free-body electric field meters

In addition to orienting the plates parallel to the floor, the arrangement of Figure A.8 may also be used with the plates oriented perpendicular to the floor.

Note that the distance to the floor, ceiling and walls should still be greater than one plate spacing. Using the perpendicular plate orientation an insulating support can be easily fixed in the plane of zero potential between the two plates as shown in Figure A.9.

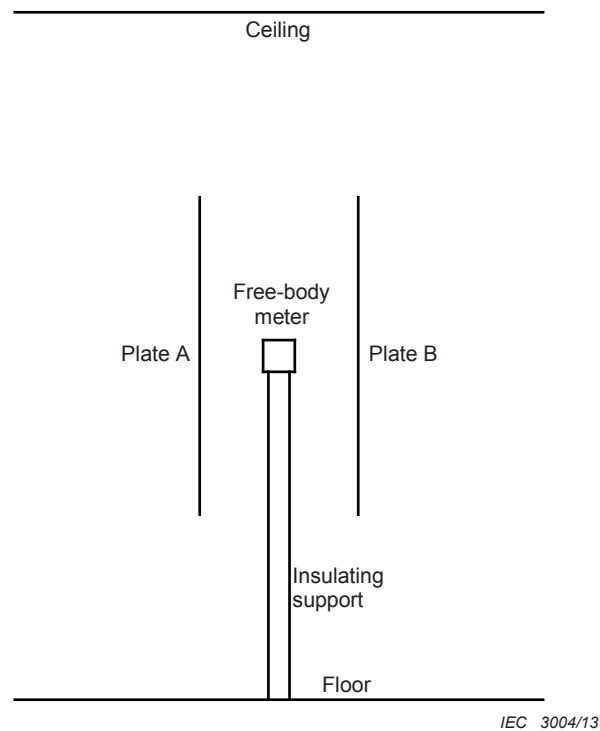

Figure A.9 – Arrangement with parallel plates orientated perpendicular to the floor

For calibrations of ground reference type field meters, the arrangement designed to energize the parallel plates as shown in Figure A.8 is modified so that the bottom plate is at ground potential and is used as a support for the flat probe.

Because of the increased distance between the probe and top plate, the perturbation of the surface charge distribution on the top plate by the probe is greatly reduced (compared with free-body meters midway between the plates). This decreased perturbation permits reduction of the parallel plate spacing previously indicated (0,75 m) and thereby increases the lateral extent of the nearly uniform field region (see Figure A.7 and Table A.1). The parallel plate spacing should be no larger than 1,5 times the side dimension of the probe, and the edges of the probe should be no closer than two plate spacings to any edge of the bottom plate. The distance between the parallel plates and the nearest ground plane (walls, floor, etc.) should be greater than two plate spacings. The guard band should be at least as wide as 6 % of the side dimension and the thickness of the probe should not exceed 3,5 % of its side dimension. With the above restrictions the calibration field will be within 0,5 % of the uniform field value V/d (uncertainties in the values of V and d should be combined with the 0,5 %) [22].

NOTE Comparisons of the electric field meter readings with the calibration field values enables the determination of correction factors that should be applied to readings when measurements are performed. Alternatively, the comparisons allow corrective adjustments to be made in the detector circuit. In either case, the uncertainty associated with the above calibration processes is equal to the uncertainty in the value of the calibration field values (once the corrections have been made) combined with uncertainties related to the stability and resolution of the field meter readings.

A.2.2 Current injection method

Free-body and ground reference field meters, in their initial response to an electric field, can be considered as current measuring devices². Therefore, if the ratio of induced current to electric field I/E for an electric field meter is determined by calibration, a current injection scheme may be used later as a means for verifying the instrument calibration if parallel plates are unavailable [19]. Figure A.10 shows a circuit that can be used for injecting known currents into the sensing electrodes of a free-body-type meter. In Figure A.10, V is the voltage produced by a function generator and Z is a known impedance at least two orders of magnitude greater than the input impedance of the field meter. Although Z may consist of capacitors or resistors, resistors are preferred because the impedance of capacitors will change when the current injection technique is used at different frequencies. Further, if there are harmonics in the voltage source, smaller errors will be introduced with the use of resistors. The injected current can be calculated from Ohm's law.

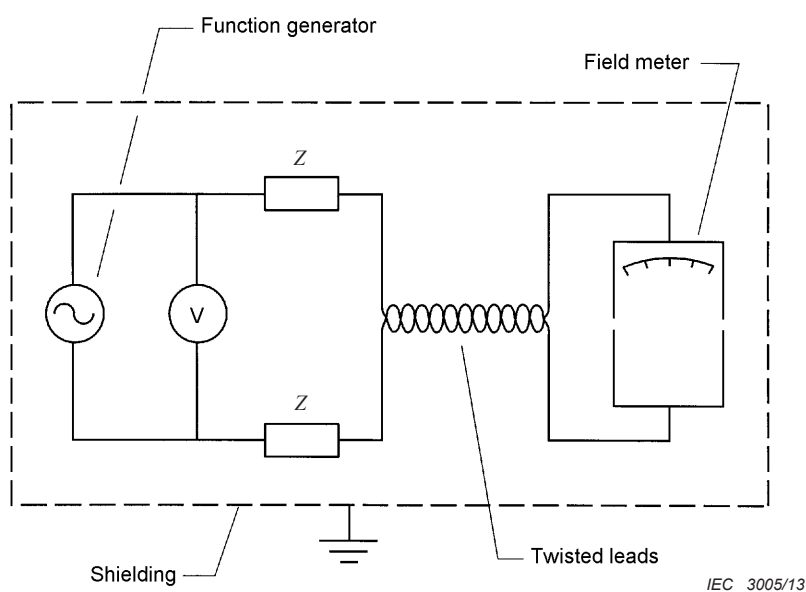

Although Z may represent either capacitors or resistors, resistors are preferred (see text in Clause A.2).

Figure A.10 – Diagram for current injection technique

A circuit similar to the one shown in Figure A.10 may be used for injecting currents into ground-reference-type field meters. In this case, the impedance on the ground side of the voltage source is removed and the remaining impedance is doubled in value.

Adequate shielding is required when the current injection technique is employed in order to minimize signal contributions from such sources as nearby lighting and electrical equipment. Enclosing the current injection circuit and field meter with a grounded metal screen can reduce the signal contributions from background sources to negligible levels. The validity of the current injection approach assumes that the ratio I/E is determined soon after calibration of the field meter in a known electric field and that the field meter probe has not been modified since its calibration.

A.2.3 Comparison with electric field reference

The method is the same as described in A.1.3.

² Afterwards, if there is a stage of integration in the detector circuit, the field meter reading will be proportional to the induced charge which tracks the waveform of the electric field.

Annex B (informative)

Example of calibration uncertainty

Table B.1 gives an example of calculation of calibration uncertainty for **B** field using an Helmholtz coils system. A magnetic field of 100 μT is assumed. The uncertainty sources come from the analysis of the calibration system described in Annex A.

Table B.1 – Example of uncertainty calculation

| Uncertainty sources | Reference | Value of the uncertainty uv_i | Probability distribution | Division factor k_i | Sensitivity coefficient C_i | Standard uncertainty $u_i = uv_i / k_i$ |
|---|-----------|------------------------------------|---|--------------------------|----------------------------------|--|
| Statistic | | | | | | |
| Repeatability | A1 | $2,0 \cdot 10^{-4}$ | | $\sqrt{5}$ | 1 | $8,95 \cdot 10^{-5}$ |
| Reproducibility | A2 | $3,0 \cdot 10^{-4}$ | | $\sqrt{3}$ | 1 | $1,73 \cdot 10^{-4}$ |
| Equipment | | | | | | |
| Calibration of the amperemeter | BR1 | $7,1 \cdot 10^{-4}$ | Normal | 2 | 1 | $3,55 \cdot 10^{-4}$ |
| Drift of the amperemeter | BR2 | $1,2 \cdot 10^{-4}$ | Rectangular | $2\sqrt{3}$ | 1 | $3,46 \cdot 10^{-5}$ |
| Resolution of the amperemeter | BL1 | $\pm 1,0 \cdot 10^{-6}$ | Rectangular | $\sqrt{3}$ | 1 | $5,77 \cdot 10^{-7}$ |
| Interpolation of the amperemeter | BL2 | $\pm 2,9 \cdot 10^{-4}$ | Rectangular | $\sqrt{3}$ | 1 | $1,67 \cdot 10^{-4}$ |
| Influence of the temperature on the amperemeter | BL3 | 0 | U-shaped | $2\sqrt{2}$ | 1 | 0 |
| Physical characteristics of the Helmholtz coils | BL4 | $1,0 \cdot 10^{-3}$ | Normal | 2.58 | 1 | $3,88 \cdot 10^{-4}$ |
| Influence of the temperature on the Helmholtz coils | BL5 | 0 | U-shaped | $2\sqrt{2}$ | 1 | 0 |
| Influence of the current source | BL6 | 0 | Rectangular | $2\sqrt{3}$ | 1 | 0 |
| Stability of the device under test | BLX | | Rectangular | $\sqrt{3}$ | 1 | 0 |
| Environmental parameters | | | | | | |
| Noise | BL7 | $5,0 \cdot 10^{-4}$ | Rectangular | $2\sqrt{3}$ | 1 | $1,5 \cdot 10^{-4}$ |
| Combined standard uncertainty | | | $u_c = \sqrt{\sum_1^m c_i^2 \cdot u_i^2}$ | | | $6,04 \cdot 10^{-4}$ |
| Expanded uncertainty (95 % confidence interval) | | | Normal | $u_e = 2u_c$ | | $1,2 \cdot 10^{-3}$ |

- A1: number of repetition of measurements N . $k_i = \sqrt{N}$
- A2: the value of uncertainty comes from inter laboratory comparison
- BR1: the value comes from last calibration certificates of amperemeter
- BR2: variation between calibration of amperemeter
- BL1: variation of the last digit of the amperemeter
- BL2: due to the fact that the amperemeter is not used on the points where it was calibrated
- BL3: negligible
- BL4: uncertainty of the physical dimensions of the coils, value chosen 10^{-3} at 99 %
- BL5: negligible
- BL6: negligible here but to be defined in function of the meter calibrated and of its stability
- BL7: noise
- BLX: the variation of the measuring instrument itself is neglected

Annex C (informative)

General characteristics of magnetic and electric fields

C.1 General

Magnetic and electric fields produced by power lines, appliances and transportation systems can be characterized according to their magnitude, frequency, waveform (harmonic content), degree of polarization, spatial variation, and temporal variation. These characteristics are described briefly because of their importance in specifying requirements for instrumentation used to measure the fields.

NOTE This standard does not consider transient temporal variations, i.e. events that occur in a time that is short compared to the period of the magnetic and electric fields.

C.2 Polarisation

Several of the above field parameters can be introduced by considering the case of magnetic fields produced by three-phase power lines. Some of the same parameters are also used to characterize electric fields. In general, the field at a point in space can be represented as a rotating vector that traces an ellipse for every cycle of the currents in the conductors as shown schematically in Figure C.1a [4]. The rms magnitude and direction of the semi-major axis of the field ellipse, given by M in Figure C.1a, indicate the magnitude and direction of the maximum field. Similarly, the rms magnitude and direction of the semi-minor axis, given by m in Figure C.1a, describe the magnitude and direction of the minimum field. Such fields are said to be elliptically polarized.

Because fields in environments situated away from power lines can also be produced by multiple sources that are not necessarily in phase, elliptically polarized fields can occur in many settings (e.g. the home, the work place, etc.). Depending on the geometry and currents or voltage in the conductors, the degree of field polarization at a given point can vary from linear ($m = 0$) to circular ($m = M$) as shown in Figures C.1b and C.1c. This discussion of polyphase fields assumes that there are no harmonics in the field. The polarization state of fields with a significant harmonic content is more complicated[21], [30].

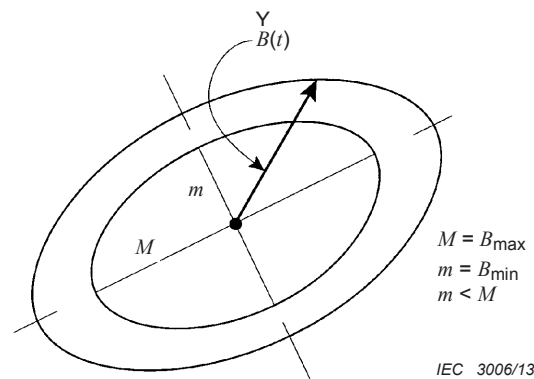

Figure C.1a – Quantities for elliptical polarization, $m < M$

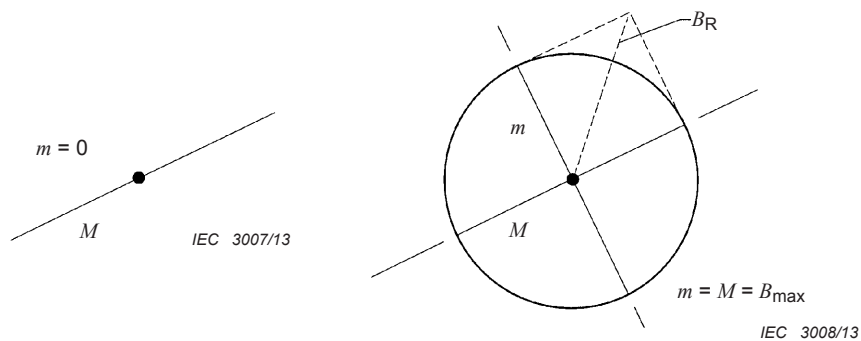

Figure C.1b – Quantities for linear polarization, $m = 0$

Figure C.1c – Quantities for circular polarization, $m = M$

The resultant B_R and the maximum magnetic field M are equal only for the case of linear polarization. The largest difference between the resultant and maximum magnetic field occurs for circular polarization, i.e. B_R exceeds M by 41 %.

Figure C.1 – Oscillating and rotating field quantities for cases of elliptical polarization, linear polarization, and circular polarization

C.3 Characteristics of magnetic field

Near ground level the magnitude of the magnetic field from a three-phase transmission line changes slowly as a function of the height of the measurement point above ground. For example, for a typical 500 kV line, the change in the magnetic field magnitude at a height of approximately 1 m above ground level is less than 2 % for a 10 % change in the measurement height for locations underneath the line. The uniformity increases at more distant points [11] .

For locations far from the line, the magnitude of the magnetic field from a single-circuit three-phase line, with balanced or nearly balanced currents, decreases approximately as $1/r^2$, where r is the lateral distance from the line (r is assumed to be much greater than the conductor spacing) [26] . As the current imbalance increases, the decrease in magnetic field magnitude changes from a $1/r^2$ to a $1/r$ dependence [26], [33]. The magnetic field from balanced double-circuit three-phase lines with low reactance phasing (i.e. for identical or nearly identical load currents for both circuits) decreases approximately as $1/r^3$ where r is again much larger than conductor spacing. The temporal variations of the magnetic field is a function of load current variations, e.g. during heavy usage of electrical energy, the load currents increase and produce greater magnetic fields (the concurrent sagging of the conductors can also contribute to greater field levels).

NOTE While the magnetic field at and near ground level beneath a polyphase power line can be represented as a rotating vector or field ellipse, the electric field becomes linearly polarized at ground level.

Other commonly encountered sources of magnetic fields are straight conductors (e.g. connections to grounding systems/electrodes) and approximately circular turns of wire (e.g. found in transformers, motors, video display terminals) with single-phase currents. The magnetic field lines and vectors at representative points from such sources are shown schematically in figures C.2a and C.2b. The magnetic fields are usually linearly polarized and the time-dependence of the oscillating vectors depends on the waveform of the currents. Sinusoidal currents produce sinusoidal magnetic fields free of harmonics, and non-sinusoidal currents (e.g. the sawtooth waveforms from television deflection coils) produce non-sinusoidal magnetic fields that can be rich in harmonics [12]. The magnitudes of magnetic fields produced by currents in an infinitely long straight wire and a circular loop of wire decrease as $1/r$ [10] and $1/r^3$ [31], respectively, where r is the distance from the field source (in the latter case it is assumed that r is much greater than the radius of the circular loop of wire).

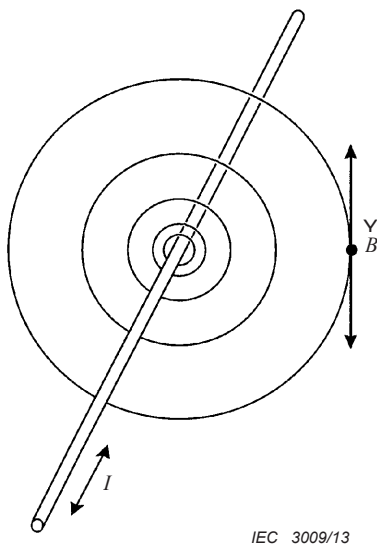

IEC 3009/13

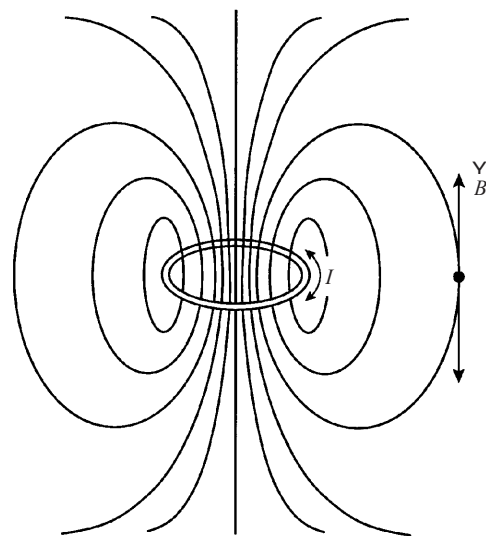

IEC 3010/13

Figure C.2a – Current in straight conductor

Figure C.2b – Current in circular conductor

Figure C.2 – Magnetic field from current in straight and circular conductors

C.4 Characteristic of electric field

Near ground level the magnitude of the electric field from a three-phase transmission line changes slowly as a function of the height of the measurement point above ground[11].

Contrary to the magnetic field, the electric field is perturbed by most objects. This is called the proximity effect. This is due to the difference of electric charge distribution between media.

Between media 1 and media 2, passage conditions are

$$E_{1t} = E_{2t} \tag{C.1}$$

and

$$\epsilon_2 E_{2n} - \epsilon_1 E_{1n} = \rho_s \tag{C.2}$$

where t = tangential component, n =normal component, ρ_s is the charge density of the surface between media

For example, a man in a 50 Hz electric field perturbs the electric field distribution (Figure C.3)

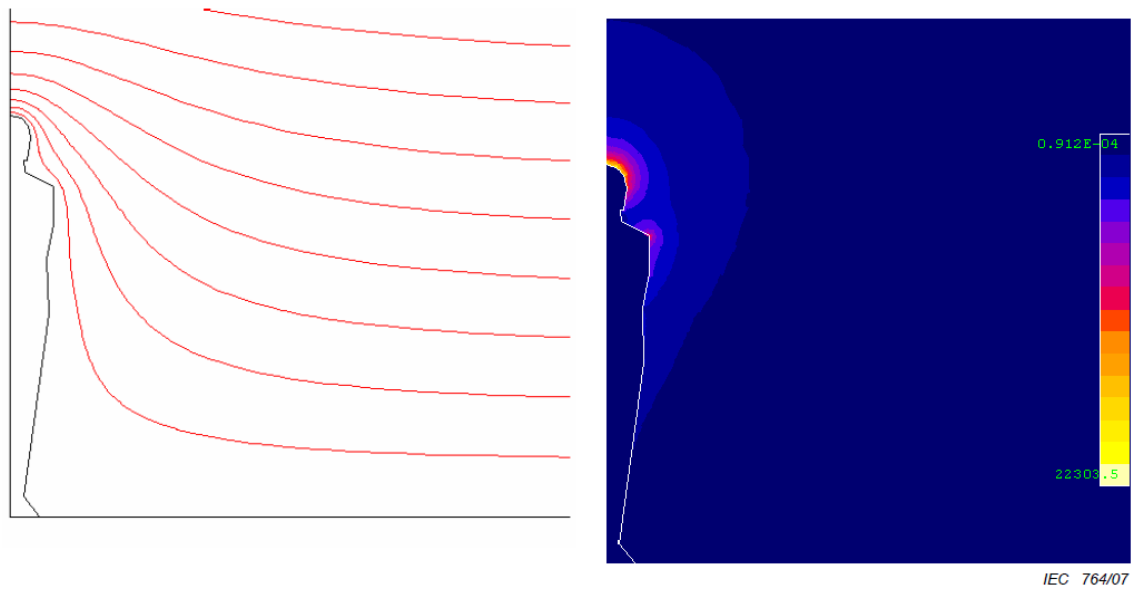
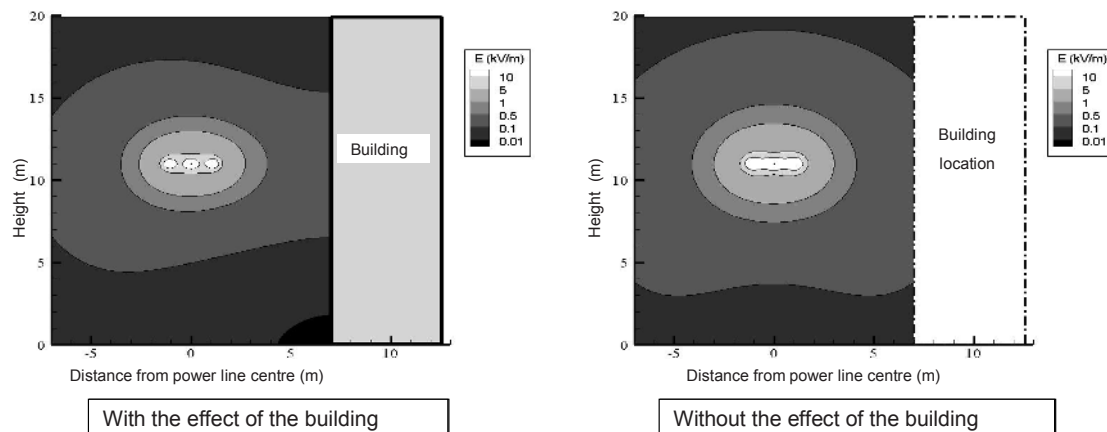

Figure C.3 – Perturbation of electric field distribution by a person (from IEC 62226-3-1)

The same phenomenon can be observed with big structures such as buildings (Figure C.4)



IEC 1621/09

Key

- Conductor height 11,0 m
- Conductor separation 1,12 m
- Building height 20,0 m, located at 7,0 m from the centre of an overhead line

Figure C.4 – Proximity effect with a 25 kV line and a building (from IEC 62110)

Annex D (informative)

Magnetic flux density meters (magnetic field meters)

D.1 General characteristics of magnetic field meters

Magnetic field meters consist of two parts, the probe or field-sensing element, and the detector, which processes the signal from the probe and indicates the rms value of the magnetic field with an analogue or digital display. Magnetic field probes, consisting of an electrically shielded coil of wire (i.e. a "single-axis" probe), have been used in combination with a voltmeter as the detector for survey type measurements of power frequency magnetic fields from power lines [13]. A diagram of this kind of instrumentation, which is one example of a survey meter, is shown in Figure D.1. While not indicated in Figure D.1, components of the detector circuit are sometimes incorporated with the probe. Magnetic field meters measure the component of the oscillating (linearly polarized) or rotating (elliptically or circularly polarized) magnetic field vector that is perpendicular to the area of the probe(s). The direction normal to the area of the probe coincides with the sensitive axis of the probe.

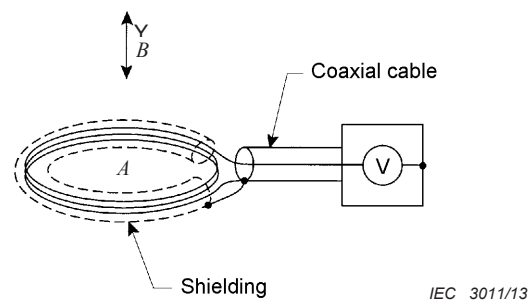

Figure D.1 – Schematic view of simple magnetic field meter with coil-type probe

For measurements in environments where the harmonic components in the magnetic field may not be negligible (e.g. industrial and residential settings, transportation systems), a stage of integration (active or passive) is made part of the detector circuit in order to preserve the waveform of the magnetic field (see Clause D.2). Typically, no provision is made for the storage of data, although output connectors for commercially available recorders are sometimes provided. To characterize the harmonic content in the magnetic field, the detector signal (which reflects the waveform of the magnetic field) can be examined using commercially available spectrum analysers to obtain the amplitudes of the fundamental and harmonic components. Three-axis magnetic field meters are also available, which can be switched or tuned to indicate the rms values of the power frequency and one or more harmonic field components.

During survey type measurements of the magnetic field, the probe can be held by hand without significant perturbation of the field due to the proximity of the observer. Proximity effects of nearby dielectrics are also insignificant. Proximity effects of small non-ferrous conductors are usually weak and located near the conductor surface, i.e. magnetic fields associated with eddy currents induced in the conductor by the time-variation of the magnetic field will perturb the field locally. Large non-ferrous metal structures can significantly perturb the field over an extended region, e.g. the interior of some mobile homes. Magnetic fields near ferrous objects are significantly perturbed.

For long-term and/or more comprehensive measurement applications, the survey-type field meter can be replaced with instrumentation which records the readings of the field in a data storage system [12], [30]. The recordings of the field can be made automatically at

predetermined time intervals, triggered by the user, or triggered by some other source, such as position-detecting equipment.

The recorded field values can often be downloaded to a computer at a later date for subsequent analysis. Alternatively, a simple analysis may be performed by the instrument itself.

Both survey meters and logging instruments can be single-axis or three-axis (although logging instruments are more likely to be three-axis). Three-axis instruments can have three coil probes or sensing elements (e.g. circular coil probes with orthogonal axes) which detect the field along three mutually orthogonal directions. The signal from each sensing element of three-axis meters can be processed by the detector in one of two ways. In one approach, the detector determines the rms value of each spatial component, squares and sums them, and then takes the square root of the sum. In the other approach, the detector squares the signal from each sensor, takes the square root of the sum, and then determines the rms value of the square root. Both methods yield the same result, which is the resultant magnetic field B_R , as defined by Equation (3). In general, the resultant magnetic field is not equal to the maximum magnetic field, varying from 100 % (for linearly polarized fields) to 141 % (for circularly polarized fields) of the maximum magnetic field.

It should be noted that B_R is also equal to the rms total magnetic flux density [16], regardless of the phases of the orthogonal components. One consequence of the phase independence is that B_R is not unique, in the sense that the same resultant magnetic field can be produced by magnetic fields with different geometries, e.g. a linearly polarized magnetic field with orthogonal components $B_0 \sin \omega t$ and $B_0 \sin \omega t$, and a circularly polarized magnetic field with orthogonal components $B_0 \sin \omega t$ and $B_0 \cos \omega t$ will have the same resultant B_0 .

The development in recent years of small personal exposure meters for the measurement of magnetic fields, devices that can be worn to measure periodically and record the three (rms) spatial components of the magnetic field, has also led to the use of miniature coil probes, sometimes containing ferromagnetic cores for increased sensitivity [12]. The orthogonally oriented probes in exposure meters, while in close proximity to one another, may not share a common central point, i.e. the probes are at different locations. Exposure meters are equipped with a computer interface which permits the downloading of the recorded field values to a computer for later analysis. Other types of field meters with high permeability inductor probes, such as the fluxgate magnetometer [27], have been adapted for alternating and/or static field measurements.

Yet more sophisticated instrumentation is available that periodically records the magnetic field waveform of the three orthogonal field components at the same instant, and thus contains magnitude, phase, and frequency information that is subsequently analysed for degree of polarization, harmonics, etc. [30].

Also available are magnetic field meters with Hall effect probes that can be used to measure magnetic flux densities from zero hertz to several hundred hertz. However, because of their low sensitivity and saturation problems due to the earth's field, they are not suited for low level a.c. field environments, e.g. in the vicinity of power lines and in residences.

D.2 Theory of operation (coil probes)

The principle of operation of the magnetic field meter shown in Figure D.1 is based on Faraday's law which predicts that a voltage V is produced at the ends of an open loop of wire placed in a changing magnetic field. Specifically, the voltage is equal to the negative of the time-rate-of-change of the flux ϕ through the loop, as given by

$$V = -\frac{d\phi}{dt} = -\frac{d}{dt} \left[\int_A \mathbf{B} \cdot \mathbf{n} dA \right] \quad (\text{D.1})$$

where

\mathbf{B} is the magnetic flux density;

\mathbf{n} is a unit vector perpendicular to the area of the loop;

dA is an element of the area A of the loop.

V will be in units of volts when A and \mathbf{B} are in square meters and tesla, respectively.

If the magnetic field is free of harmonics, e.g. $B = B_0 \sin \omega t$, and perpendicular to the area of the probe, then

$$V = -\omega B_0 A \cos \omega t \quad (\text{D.2})$$

where the angular frequency ω is equal to 2π times the frequency.

For N turns of wire in the loop, the voltage given by Equation (D.2) will develop across each turn and the total voltage will be $-N\omega B_0 A \cos \omega t$. Equation (D.2) shows that the sensitivity increases with the area of the probe.

Coil probe can also be used to measure static (d.c.) magnetic flux density if the probe is rotated.

If there are harmonics in the magnetic field, there will be an additional term on the right side of Equation (D.2) for each harmonic. Because of the differentiation operation (Equation (D.1)), each of the additional terms will be weighted by the associated harmonic number. For example, if there were 10 % third harmonic in the field, the term $-3 \times 0,1 \times \omega B_0 A \cos 3\omega t$ would be added to the right side of Equation (D.2). Because of the weighting of the harmonic term, the waveform of the signal will no longer reflect the waveform of the field. Consequently, the rms value indicated by the voltmeter-detector (see Figure D.2) will not accurately represent the rms value of the field. The waveform does, however, give a good approximation of the time-variation of the voltage or current induced in conducting materials.

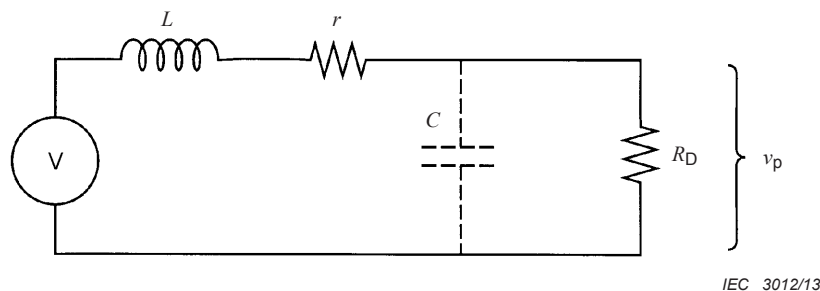

Key

L coil inductance

r wire resistance

C stray capacitance

R_D input impedance of detector

Figure D.2 – Approximate equivalent circuit of a coil probe when connected to the detector

To recover the magnetic field waveform it is necessary for the detector to perform the inverse mathematical operation, namely integration. This can be accomplished by introducing a stage of integration in the detector³. For example, the integration stage can be combined with the probe in the form of passive components, or an integrating operational amplifier can be incorporated into the detector. The frequency response of the probe-integrating detector combination should be made flat over the frequency range of interest. Filters and adequate electric field shielding should be part of the detector circuit design to exclude unwanted signals.

D.3 Static magnetic field-measuring instrumentation

Measurements of static magnetic fields can be performed accurately with a range of commercially available instrumentation employing a variety of measurement techniques [20], [14]. For example, fluxgate magnetometers, nuclear magnetic resonance (NMR) field meters, Hall effect field meters, magnetoresistive field meters and the superconducting quantum interference device (SQUID) magnetometers are a few of the instruments available.

The range of measurement of these meters depends on the measurement technique used. They cannot be used for measuring the static magnetic field in all environments. For example, Fluxgate magnetometers have adequate sensitivity to measure fields in the range of 0,1 μT (and lower) to 0,01 T, and are adapted for DC high voltage networks environments.

Hall-effect meters can readily measure levels between 100 μT and 10 T [20]. In the same order of magnitude, the very high accuracy of NMR magnetic field meters enables them to be used as a reference standard.

Standard reference magnets are commercially available for calibration purposes at relatively high field levels, e.g. 0,005 T to 2 T. The coil systems referred to in Clause A.1 can be used to generate known static fields with lower values if direct currents are used to energize the coils. However, the influence of the background static field should be considered when significant in magnitude compared to the calibration field. Standard reference magnets are available with magnetic shields to prevent perturbations from external magnetic fields. The background static field may also be cancelled using a set of auxiliary coils, by doing first a calibration with a zero current, and subtracting the value.

3 If the signal is digitized, the integration can be done by computation

Annex E (informative)

Electric field strength meters (electric field meters)

E.1 General characteristics of electric field meters

Electric field strength meters consist of two parts, the probe or field-sensing element and the detector, which processes the signal from the probe and indicates the rms value of the electric field strength in units of volts per meter using an analogue or digital display. The following two types of electric field meters are considered in this standard:

- a) the free-body meter;
- b) the ground reference meter.

When measurements of the electric field strength are performed, the observer should be sufficiently removed from the probe to avoid significant perturbation of the field at the location of the probe. Free-body meters should be sufficiently small so that the size of the probe does not significantly perturb the charge distributions on boundary surfaces generating the electric field, i.e. energized and grounded surfaces. Although field meters are calibrated in nearly uniform electric fields, the field that is measured need not be very uniform. Electric field meters measure the projection of the oscillating (linearly polarized) or rotating (elliptically or circularly polarized) electric field vector onto the electrical axis of the probe (the axis of greatest electric field sensitivity). Three-axis free-body electric field meters are available for measuring the resultant electric field.

E.2 Theory of operation

E.2.1 Free-body meters

Free-body meters are commonly constructed to measure the induced current between two isolated parts of a conductive body. Since the induced current is proportional to the time derivative of the electric field strength, the meter's detector circuit often contains an integrating stage in order to recover the waveform of the electric field. The integrated current waveform also coincides with that of the induced charge. The integrating stage is also desirable, particularly for the measurement of electric fields with harmonic content, because this stage (i.e. its integrating property) eliminates the excessive weighting of the harmonic components in the induced current signal.

Free-body meters determine the electric field strength by measuring the steady-state induced current or charge oscillating between the conducting halves (electrodes) of an electrically isolated probe, after the probe has been introduced into the electric field. For commercially available free-body meters, the detector is usually contained in or is an integral part of the probe. The probe and detector are supported in the electric field at the end of an insulating handle [5], [13]. The free-body meter is suitable for survey type measurements because it is portable, allows measurements above the ground plane, and does not require a ground reference potential. Single-axis and three-axis free-body meters are commercially available. Free-body meters are normally battery-powered.

There are also free-body meters designed for remote display of the electric field strength. In this case, a portion of the signal-processing circuit is contained in the probe and the remainder of the detector is in a separate enclosure with an analogue or digital display. A fibre-optic link connects the probe to the display unit [9], [17].

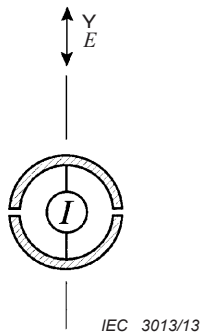

Figure E.1a – Spherical free-body electric field meter

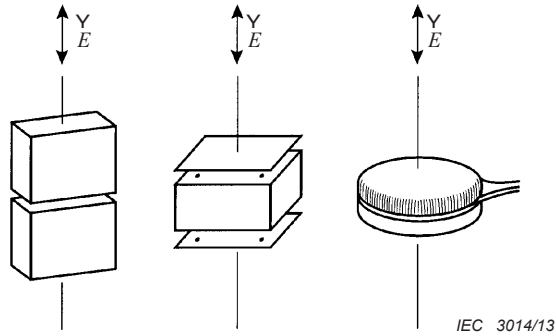

Figure E.1b – Commercial single-axis electric field meters

Figure E.1 – Single-axis free-body meter geometries

Figure E.1 shows examples of single-axis free-body meter geometries. The theory of operation of free-body meters can be understood by considering an uncharged conducting body with separated halves or electrodes, introduced into a uniform electric field E . The charge induced on one of the electrodes is

$$Q = \int_{S/2} \mathbf{D} \cdot \mathbf{n} \, dA \quad (\text{E.1})$$

where

\mathbf{D} is the electric displacement;

\mathbf{n} is a unit vector perpendicular to the surface of the electrode;

dA is an element of area on half of the body with total surface S .

The case of spherical geometry as shown in Figure E.1a yields the following result:

$$Q = 3\pi a^2 \varepsilon_0 E \quad (\text{E.2})$$

where

ε_0 is the permittivity of free space;

a is the radius of the sphere [29].

NOTE The surface charge density is given by $3\varepsilon_0 E \cos\theta$. Integration over the hemisphere gives Equation (E.2) (see [29]).

For less symmetric geometries, the result can be expressed as

$$Q = k \varepsilon_0 E \quad (\text{E.3})$$

where k is a constant dependent on the probe's geometry.

Sensing electrodes resembling cubes and parallel plates (see Figure E.1b), have been employed. If the electric field strength has a sinusoidal time dependence, for example $E_0 \sin \omega t$, where ω is the angular frequency, the induced charge oscillates between the two halves and the current is given by

$$I = \frac{dQ}{dt} = k\omega\epsilon_0 E_0 \cos\omega t \quad (\text{E.4})$$

The constant k can be thought of as a field meter constant and is determined by calibration. The influence of the handle, representing a leakage impedance, and the perturbation introduced by the observer are taken to be negligible in the above discussion.

If there are harmonics in the electric field, there will be an additional term on the right side of Equation (E.4) for each harmonic. Because of the differentiation operation in Equation (E.4), each of the additional terms will be weighted by the associated harmonic number. As in the case of the magnetic field meter (see Clause D.2), it is necessary for the detector to perform the inverse mathematical operation, namely integration, to recover the electric field waveform. This is accomplished by introducing a stage of integration. For example, an integrating amplifier or a passive integrating circuit combined with a voltmeter could be used as a detector. The frequency response of the probe-integrating detector combination should be made flat over the frequency range of interest. Filters should be used to exclude signals outside of the frequency range of interest.

E.2.2 Ground reference meters

Ground reference meters determine the electric field strength by measuring the current or charge on the sensing surface of a flat probe. Such meters are normally used to measure the electric field at ground level or on flat conducting surfaces that are at ground potential. Two probe designs have been employed. One design makes use of a single flat conductor with an isolated central section that serves as the sensing surface. Small versions of this type of probe have been made with a double-clad printed circuit board as shown in Figure E.2a. A second design consists of two parallel plates separated by a thin sheet of insulation, with the top plate acting as the sensing surface as shown in Figure E.2b.

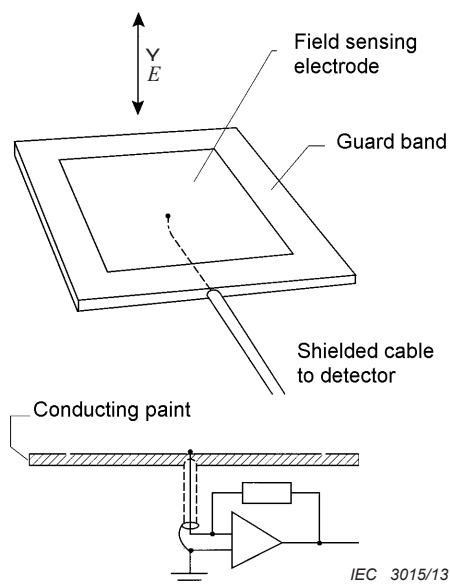

Figure E.2a – Flat probe made with double-clad printed circuit board

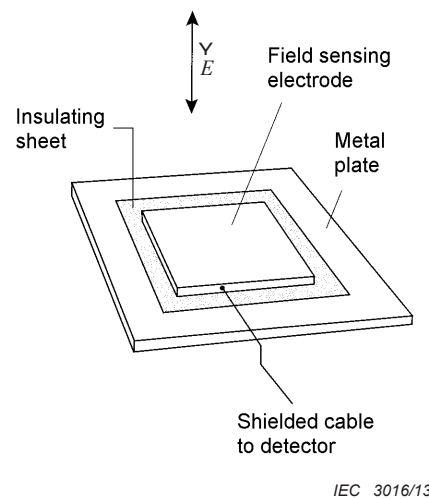

Figure E.2b – Flat probe consisting of parallel plates separated by insulating sheet

Figure E.2 – Designs for flat plate probes used with ground-referenced electric field meters

From Gauss' law, the charge Q , induced on a sensing surface with area A , is

$$Q = \varepsilon_0 EA \quad (\text{E.5})$$

where

E is the average electric field strength across the sensing surface;

ε_0 is the permittivity of free space.

Assuming that E varies sinusoidally with angular frequency ω (i.e. $E = E_0 \sin \omega t$), the resulting induced current is given by

$$I = \frac{dQ}{dt} = \omega \varepsilon_0 E_0 A \cos \omega t \quad (\text{E.6})$$

If there are harmonics in the electric field, there will again be an additional term on the right hand side of Equation (E.6) for each harmonic. As in E.2.1, because of the differentiation operation, each of the additional terms will be weighted by the associated harmonic number. To recover the electric field waveform, it is necessary to perform the inverse mathematical operation, namely integration. An integrating circuit/voltmeter combination that produces a flat frequency response over the frequency range of interest can serve as the detector. Filters should also be part of the detector circuit to exclude signals from outside the frequency range of interest. Ground reference meters may be battery or mains-operated.

NOTE Ground reference meters measuring the induced current often contain an integrator circuit to compensate for the derivative relationship between the induced current and the electric field.

Electric field meters with flat probes can be used to measure the electric field strength on flat electrically energized surfaces if the detector is operated at the same potential as the energized surface. In such cases, viewing of the analogue or digital display of the detector should be done remotely, for example visually, from a distance, or using a fibre-optic link.

Annex F (informative)

Influence of humidity on electric field measurement

F.1 Measurement conditions

In order to assess the influence of humidity on the electric field measurement, tests were carried out in a climatic chamber on the EDF R&D site “Les Renardières” [2]. The electric field was created by a 2 m diameter plate, at a height around 2 m, and with applied voltage so as to have a vertical electric field of about 10 kV/m. The climatic control was set up to maintain a temperature close to 20 °C and during the tests the temperature fluctuated actually between 18 °C and 21 °C. The humidity range tested was from 20 % to 100 %.

Three free-body type meters were tested, one was single axis (meter 1) and the two other were three-axis (meter 2 and meter 3)

The influence of the support of the meters was also tested and the meters were put on two tripods: a “normal” one (insulated tripod) and another with an insulating rod to horizontally offset the sensor (referred to as “offset tripod”). See Figure F.1.

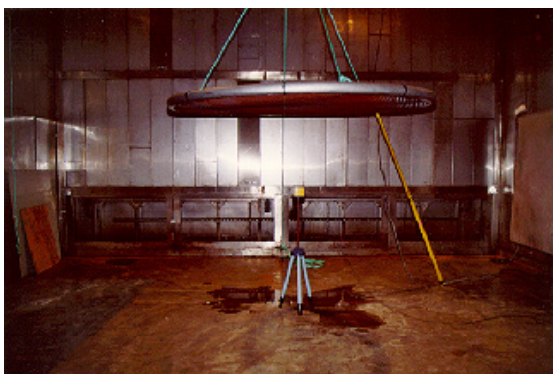

IEC 3017/13



IEC 3018/13

Figure F.1 – Test in the climatic chamber with the normal tripod (left) and the offset tripod (right) (photograph EDF R&D)

The influence of coating the support of the meter with silicon grease (hydrophobic compounds) was also tested.

F.2 Results

Figures F.2 and F.3 give the main results of the tests.

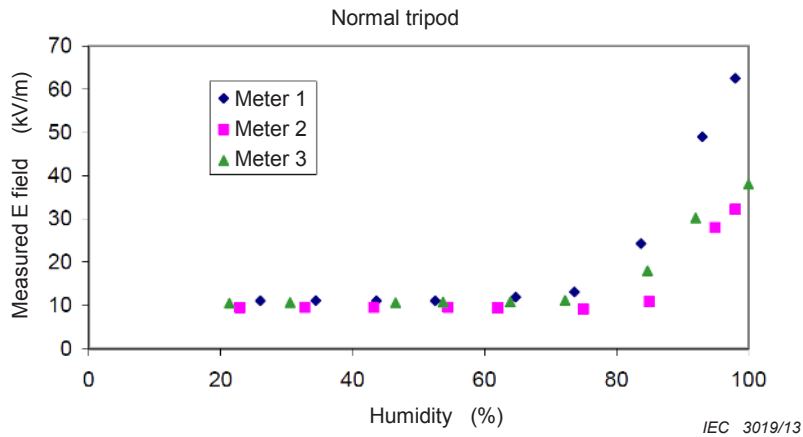

Figure F.2 – E field measured as a function of the humidity with a normal tripod

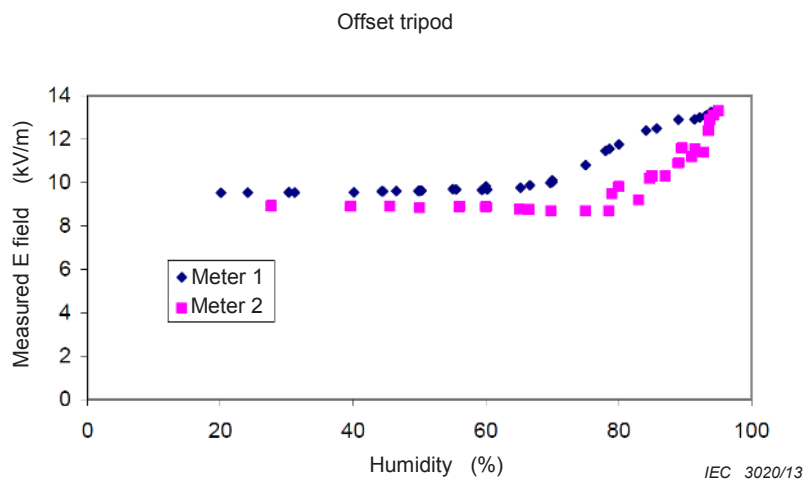

Figure F.3 – E field measured as a function of the humidity with an offset tripod

The results show the influence of the humidity on the measurement of electric field. The measured value increases with the humidity.

The drift of measured field compared to actual field is especially high with a normal tripod when the relative humidity is over 70 % (up to a 7-fold error in reading the applied field). So the offset tripod is recommended because the drift amplitude is much lower (the maximum error is only 40 % of the applied field).

The use of hydrophobic compounds (silicone grease) to coat the support has not shown any reduction of the effects of humidity.

Annex G (informative)

Units

G.1 Units

The preferred units are those taken from International System of Units (SI units) and units derived from SI units. Some commonly used SI and SI derived units are listed below.

For additional units, see [15].

G.2 SI units and SI derived units

| | |
|--------------------------|-------------------------|
| Time: | second (s) |
| Electric potential: | volt (V) |
| | kilovolt (kV) |
| Current: | ampere (A) |
| Inductance: | henry (H) |
| Resistance: | ohm (Ω) |
| Electric field strength: | volts per metre (V/m) |
| Magnetic flux density: | tesla (T) |
| Magnetic field strength: | amperes per metre (A/m) |

G.3 Useful physical constants

| | |
|---|----------------------------|
| Permeability of free space μ_0 : | $4\pi \cdot 10^{-7}$ H/m |
| Permittivity of free space ϵ_0 : | $8,854 \cdot 10^{-12}$ F/m |
| Conversion between tesla and gauss: | 1mG = 0,1 μ T |
| Conversion between tesla and amperes per metre (where $\mu = \mu_0$): B (in μ T) = $0,4 \times \pi \times$ H (in A/m) | |

Bibliography

- [1] BOTTAUSCIO, O., et al. Generation of reference electric and magnetic fields for calibration of power-frequency field meters. *IEEE Transactions on Instrumentation and Measurement*, 1993, vol. 42, no. 2, p. 547-552.
- [2] CIGRE WORKING GROUP C4.203 *Technical Guide for Measurement of Low Frequency Electric and Magnetic Fields near Overhead Power Lines*. Technical Brochure n°375, 2009.
- [3] DELAPLACE, L.R. AND REILLY, J.P. Electric and Magnetic Field Coupling from High Voltage AC Power Transmission Lines -- Classification of Short-Term Effects on People. *IEEE Transactions on Power Apparatus and Systems*, 1978, vol. PAS-97, no. 6, p. 2243-2252.
- [4] DENO, D.W. Transmission line fields. *IEEE Transactions on Power Apparatus and Systems*, 1976, vol. PAS-95, no. 5, p. 1600-1611.
- [5] DENO, D.W. Currents induced in the human body by high voltage transmission line electric field - measurement and calculation of distribution and dose. *IEEE Transactions on Power Apparatus and Systems*, 1977, vol. 96, no. 5, p. 1517-1527.
- [6] FIRESTER, A.H. Design of Square Helmholtz Coil Systems. *Review of Scientific Instruments*, 1966, vol. 37, no. 9, p. 1264-1265.
- [7] FRIX, W.M., et al. Comparison of calibration systems for magnetic field measurement equipment. *IEEE Transactions on Power Delivery*, 1994, vol. 9, no. N°1.
- [8] FULCOMER, P.M. *NBS ambient magnetic field meter for measurement and analysis of low-level power frequency magnetic fields in air*. 1985, no. NBSIR 86-3330.
- [9] GOCKENBACH, E., et al. 1989. *Some Applications of an Electric Field Sensor in the High-Voltage Technique*. In Proceedings of the Sixth International Symposium on High-Voltage Engineering, New Orleans, LA, 1989.
- [10] HALLIDAY, D. AND RESCNICK, R. *Physics, Parts I and II*. New York: Wiley & Sons, 1966. p. 861-862.
- [11] IEC 62110:2009, *Electric and magnetic field levels generated by AC power systems – Measurement procedures with regard to public exposure*
- [12] IEEE MAGNETIC FIELDS TASK FORCE. Measurements of power frequency magnetic fields away from power lines. *IEEE Transactions on Power Delivery*, 1991, vol. 6, no. 2, p. 901-911.
- [13] IEEE STD 644-1994, *IEEE Standard Procedures for Measurements of Power Frequency Electric and Magnetic Fields from AC Power Lines*
- [14] IEEE STD C95.3.1:2010, *IEEE Recommended Practice for Measurements and Computations of Electric, Magnetic and Electromagnetic Fields with Respect to Human Exposure to Such Fields, 0 Hz to 100 kHz*
- [15] ISO 80000-1:2009, *Quantities and units – Part 1: general*
- [16] KAUNE, W.T., et al. Residential magnetic and electric fields. *Bioelectromagnetics*, 1987, vol. 8, p. 315-335.

- [17] KIRKHAM, H., et al. *AC and DC Electric Field Meters Developed for the U.S. Department of Energy*. 1987, no. JPL Publication 87-20.
- [18] KIRSCHVINK, J.L. Uniform magnetic fields and double-wrapped coil systems: improved techniques for the design of bioelectromagnetic experiments. *Bioelectromagnetics*, 1992, vol. 13, no. 5, p. 401-411.
- [19] KOTTER, F.R. AND MISAKIAN, M. *AC transmission line field measurements*. 1977, no. NBS 1549 report prepared for the Department of Energy, available as report 1550 PB82133554 from NTIS, Springfield, VA 22161.
- [20] LENZ, J.E. A review of magnetic sensors. *Proceedings of the IEEE*, 1990, vol. 78, no. 6, p. 973-989.
- [21] MAMISHEV, A.V. AND RUSSELL, B.D. Measurements of magnetic fields in the direct proximity of power line conductors. *IEEE Transactions On Power Delivery*, 1995, vol. 10, no. 3, p. 1211-1216.
- [22] MISAKIAN, M. Calibration of flat 60-Hz electric field probes. *Bioelectromagnetics*, 1984, vol. 5, no. 4, p. 447-450.
- [23] MISAKIAN, M. *Discussion of {Takuma, 1985 #4269}* 1985.
- [24] MISAKIAN, M., et al. *Biological, physical, and electrical parameters for in vitro studies with ELF magnetic and electric fields: a primer*. *Bioelectromagnetics*, 1993, vol. Suppl 2, p. 1-73.
- [25] NISSEN, J. AND PAULSSON, L.E. Influence of field inhomogeneity in magnetic calibration coils. *IEEE Transactions on Instrumentation and Measurement*, 1996, vol. 45, no. 1, p. 304-306.
- [26] OLSEN, R.G., et al. Magnetic fields from electric power lines: theory and comparison to measurements. *IEEE Transactions On Power Delivery*, 1988, vol. 3, no. 4, p. 2127-2136.
- [27] PRIMDAHL, F. The fluxgate magnetometer. *Journal of Physics E: Scientific Instruments*, 1979, vol. 12, no. 4, p. 241.
- [28] RAMO, S. AND WHINNERY, J.R. *Fields and Waves in Modern Radio*. New York: John Wiley, 1944. p. 141.
- [29] REITZ, J.R. AND MILFORD, F.J. *Foundations of Electromagnetic Theory*. Reading, MA: Addison-Wesley, 1960. p. 52.
- [30] SICREE, R.M., et al. Comparison of magnetic flux density meter responses over a database of residential measurements. *IEEE Transactions On Power Delivery*, 1993, vol. 8, no. 2, p. 607-619.
- [31] STRATTON, J.A. *Electromagnetic Theory*. New York: McGraw-Hill, 1941. p. 437.
- [32] TAKUMA, T., et al. Analysis Of Calibration Arrangements For AC Field Strength Meters. Power Apparatus and Systems, *IEEE Transactions On Power Delivery*, 1985, vol. PAS-104, no. 2, p. 488-496.
- [33] VINH, T., et al. Magnetic fields near overhead distribution lines - measurements and estimating technique. *IEEE Transactions On Power Delivery*, 1991, vol. 6, no. 2, p. 912-919.

- [34] WEBER, E. *Electromagnetic Theory*. New York: Dover, 1965. p. 131-133.
- [35] IEC 60050 (all parts), *International Electrotechnical Vocabulary* (available at <<http://www.electropedia.org>>
- [36] ISO/IEC 17025:2005, General requirements for the competence of testing and calibration laboratories
-

British Standards Institution (BSI)

BSI is the national body responsible for preparing British Standards and other standards-related publications, information and services.

BSI is incorporated by Royal Charter. British Standards and other standardization products are published by BSI Standards Limited.

About us

We bring together business, industry, government, consumers, innovators and others to shape their combined experience and expertise into standards-based solutions.

The knowledge embodied in our standards has been carefully assembled in a dependable format and refined through our open consultation process. Organizations of all sizes and across all sectors choose standards to help them achieve their goals.

Information on standards

We can provide you with the knowledge that your organization needs to succeed. Find out more about British Standards by visiting our website at bsigroup.com/standards or contacting our Customer Services team or Knowledge Centre.

Buying standards

You can buy and download PDF versions of BSI publications, including British and adopted European and international standards, through our website at bsigroup.com/shop, where hard copies can also be purchased.

If you need international and foreign standards from other Standards Development Organizations, hard copies can be ordered from our Customer Services team.

Subscriptions

Our range of subscription services are designed to make using standards easier for you. For further information on our subscription products go to bsigroup.com/subscriptions.

With **British Standards Online (BSOL)** you'll have instant access to over 55,000 British and adopted European and international standards from your desktop. It's available 24/7 and is refreshed daily so you'll always be up to date.

You can keep in touch with standards developments and receive substantial discounts on the purchase price of standards, both in single copy and subscription format, by becoming a **BSI Subscribing Member**.

PLUS is an updating service exclusive to BSI Subscribing Members. You will automatically receive the latest hard copy of your standards when they're revised or replaced.

To find out more about becoming a BSI Subscribing Member and the benefits of membership, please visit bsigroup.com/shop.

With a **Multi-User Network Licence (MUNL)** you are able to host standards publications on your intranet. Licences can cover as few or as many users as you wish. With updates supplied as soon as they're available, you can be sure your documentation is current. For further information, email bsmusales@bsigroup.com.

BSI Group Headquarters

389 Chiswick High Road London W4 4AL UK

Revisions

Our British Standards and other publications are updated by amendment or revision.

We continually improve the quality of our products and services to benefit your business. If you find an inaccuracy or ambiguity within a British Standard or other BSI publication please inform the Knowledge Centre.

Copyright

All the data, software and documentation set out in all British Standards and other BSI publications are the property of and copyrighted by BSI, or some person or entity that owns copyright in the information used (such as the international standardization bodies) and has formally licensed such information to BSI for commercial publication and use. Except as permitted under the Copyright, Designs and Patents Act 1988 no extract may be reproduced, stored in a retrieval system or transmitted in any form or by any means – electronic, photocopying, recording or otherwise – without prior written permission from BSI. Details and advice can be obtained from the Copyright & Licensing Department.

Useful Contacts:

Customer Services

Tel: +44 845 086 9001

Email (orders): orders@bsigroup.com

Email (enquiries): cservices@bsigroup.com

Subscriptions

Tel: +44 845 086 9001

Email: subscriptions@bsigroup.com

Knowledge Centre

Tel: +44 20 8996 7004

Email: knowledgecentre@bsigroup.com

Copyright & Licensing

Tel: +44 20 8996 7070

Email: copyright@bsigroup.com



...making excellence a habit.™