

BS EN 61784-1:2014



BSI Standards Publication

Industrial communication networks — Profiles

Part 1: Fieldbus profiles

bsi.

...making excellence a habit.™

National foreword

This British Standard is the UK implementation of EN 61784-1:2014. It is identical to IEC 61784-1:2014. It supersedes BS EN 61784-1:2010 which is withdrawn.

The UK participation in its preparation was entrusted to Technical Committee AMT/7, Industrial communications: process measurement and control, including fieldbus.

A list of organizations represented on this committee can be obtained on request to its secretary.

This publication does not purport to include all the necessary provisions of a contract. Users are responsible for its correct application.

© The British Standards Institution 2014.

Published by BSI Standards Limited 2014

ISBN 978 0 580 79253 3

ICS 35.100.20; 35.240.50

Compliance with a British Standard cannot confer immunity from legal obligations.

This British Standard was published under the authority of the Standards Policy and Strategy Committee on 30 November 2014.

Amendments/corrigenda issued since publication

Date	Text affected
-------------	----------------------

EUROPEAN STANDARD

EN 61784-1

NORME EUROPÉENNE

EUROPÄISCHE NORM

October 2014

ICS 35.100.20; 35.240.50

Supersedes EN 61784-1:2010

English Version

**Industrial communication networks - Profiles - Part 1: Fieldbus
profiles
(IEC 61784-1:2014)**

Réseaux de communication industriels - Profils - Partie 1:
Profils de bus de terrain
(CEI 61784-1:2014)

Industrielle Kommunikationsnetze - Profile - Teil 1:
Feldbusprofile
(IEC 61784-1:2014)

This European Standard was approved by CENELEC on 2014-09-23. CENELEC members are bound to comply with the CEN/CENELEC Internal Regulations which stipulate the conditions for giving this European Standard the status of a national standard without any alteration.

Up-to-date lists and bibliographical references concerning such national standards may be obtained on application to the CEN-CENELEC Management Centre or to any CENELEC member.

This European Standard exists in three official versions (English, French, German). A version in any other language made by translation under the responsibility of a CENELEC member into its own language and notified to the CEN-CENELEC Management Centre has the same status as the official versions.

CENELEC members are the national electrotechnical committees of Austria, Belgium, Bulgaria, Croatia, Cyprus, the Czech Republic, Denmark, Estonia, Finland, Former Yugoslav Republic of Macedonia, France, Germany, Greece, Hungary, Iceland, Ireland, Italy, Latvia, Lithuania, Luxembourg, Malta, the Netherlands, Norway, Poland, Portugal, Romania, Slovakia, Slovenia, Spain, Sweden, Switzerland, Turkey and the United Kingdom.



European Committee for Electrotechnical Standardization
Comité Européen de Normalisation Electrotechnique
Europäisches Komitee für Elektrotechnische Normung

CEN-CENELEC Management Centre: Avenue Marnix 17, B-1000 Brussels

Foreword

The text of document 65C/760/FDIS, future edition 4 of IEC 61784-1, prepared by IEC/TC 65C "Industrial networks, of IEC technical committee 65: Industrial-process measurement, control and automation was submitted to the IEC-CENELEC parallel vote and approved by CENELEC as EN 61784-1:2014.

The following dates are fixed:

- latest date by which the document has to be implemented at national level by publication of an identical national standard or by endorsement (dop) 2015-06-23
- latest date by which the national standards conflicting with the document have to be withdrawn (dow) 2017-09-23

This document supersedes EN 61784-1:2010.

Attention is drawn to the possibility that some of the elements of this document may be the subject of patent rights. CENELEC [and/or CEN] shall not be held responsible for identifying any or all such patent rights.

Endorsement notice

The text of the International Standard IEC 61784-1:2014 was approved by CENELEC as a European Standard without any modification.

In the official version, for Bibliography, the following notes have to be added for the standards indicated:

IEC 60079-14	NOTE	Harmonised as EN 60079-14.
IEC 60793 (Series)	NOTE	Harmonised as EN 60793 (Series).
IEC 61131-3	NOTE	Harmonised as EN 61131-3.
IEC 61158-1	NOTE	Harmonised as EN 61158-1.
IEC 61800-7-204	NOTE	Harmonised as EN 61800-7-204.
ISO/IEC 7498-3	NOTE	Harmonised as EN ISO/IEC 7498-1.

Annex ZA (normative)

Normative references to international publications with their corresponding European publications

The following documents, in whole or in part, are normatively referenced in this document and are indispensable for its application. For dated references, only the edition cited applies. For undated references, the latest edition of the referenced document (including any amendments) applies.

NOTE 1 When an International Publication has been modified by common modifications, indicated by (mod), the relevant EN/HD applies.

NOTE 2 Up-to-date information on the latest versions of the European Standards listed in this annex is available here: www.cenelec.eu.

<u>Publication</u>	<u>Year</u>	<u>Title</u>	<u>EN/HD</u>	<u>Year</u>
IEC 60079-11	-	Explosive atmospheres -- Part 11: Equipment protection by intrinsic safety "i"	EN 60079-11	-
IEC 60079-25	-	Explosive atmospheres -- Part 25: Intrinsically safe electrical systems	EN 60079-25	-
IEC 61010	series	Safety requirements for electrical equipment for measurement, control and laboratory use	+AC -	2013 series
IEC 61131-2	-	Programmable controllers -- Part 2: Equipment requirements and tests	EN 61131-2	-
IEC 61158	series	Industrial communication networks - Fieldbus specifications	EN 61158	series
IEC 61158-2	2014	Industrial communication networks - Fieldbus specifications - Part 2: Physical layer specification and service definition	EN 61158-2	2014
IEC 61158-3-1	2014	Industrial communication networks - Fieldbus specifications - Part 3-1: Data-link layer service definition - Type 1 elements	EN 61158-3-1	2014
IEC 61158-3-2	2014	Industrial communication networks - Fieldbus specifications - Part 3-2: Data-link layer service definition - Type 2 elements	EN 61158-3-2	2014
IEC 61158-3-3	2014	Industrial communication networks - Fieldbus specifications - Part 3-3: Data-link layer service definition - Type 3 elements	EN 61158-3-3	2014
IEC 61158-3-4	2014	Industrial communication networks - Fieldbus specifications - Part 3-4: Data-link layer service definition - Type 4 elements	EN 61158-3-4	2014
IEC 61158-3-7	2007	Industrial communication networks - Fieldbus specifications - Part 3-7: Data-link layer service definition - Type 7 elements	EN 61158-3-7	2008
IEC 61158-3-8	2007	Industrial communication networks - Fieldbus specifications - Part 3-8: Data-link layer service definition - Type 8 elements	EN 61158-3-8	2008
IEC 61158-3-16	2007	Industrial communication networks - Fieldbus specifications - Part 3-16: Data-link layer service definition - Type 16 elements	EN 61158-3-16	2008
IEC 61158-3-18	2007	Industrial communication networks - Fieldbus specifications - Part 3-18: Data-link layer service definition - Type 18 elements	EN 61158-3-18	2008
IEC 61158-3-19	2014	Industrial communication networks - Fieldbus specifications - Part 3-19: Data-link layer service definition - Type 19 elements	EN 61158-3-19	2014

IEC 61158-3-20	2014	Industrial communication networks - Fieldbus specifications - Part 3-20: Data- link layer service definition - Type 20 elements	EN 61158-3-20	2014
IEC 61158-3-24	2014	Industrial communication networks - Fieldbus specifications - Part 3-24: Data- link layer service definition - Type-24 elements	EN 61158-3-24	2014
IEC 61158-4-1	2014	Industrial communication networks - Fieldbus specifications - Part 4-1: Data-link layer protocol specification - Type 1 elements	EN 61158-4-1	2014
IEC 61158-4-2	2014	Industrial communication networks - Fieldbus specifications - Part 4-2: Data-link layer protocol specification - Type 2 elements	EN 61158-4-2	2014
IEC 61158-4-3	2014	Industrial communication networks - Fieldbus specifications - Part 4-3: Data-link layer protocol specification - Type 3 elements	EN 61158-4-3	2014
IEC 61158-4-4	2014	Industrial communication networks - Fieldbus specifications - Part 4-4: Data-link layer protocol specification - Type 4 elements	EN 61158-4-4	2014
IEC 61158-4-7	2007	Industrial communication networks - Fieldbus specifications - Part 4-7: Data-link layer protocol specification - Type 7 elements	EN 61158-4-7	2008
IEC 61158-4-8	2007	Industrial communication networks - Fieldbus specifications - Part 4-8: Data-link layer protocol specification - Type 8 elements	EN 61158-4-8	2008
IEC 61158-4-16	2007	Industrial communication networks - Fieldbus specifications - Part 4-16: Data- link layer protocol specification - Type 16 elements	EN 61158-4-16	2008
IEC 61158-4-16	2007	Industrial communication networks - Fieldbus specifications - Part 4-16: Data- link layer protocol specification - Type 16 elements	EN 61158-4-16	2008
IEC 61158-4-18	2010	Industrial communication networks - Fieldbus specifications -- Part 4-18: Data- link layer protocol specification - Type 18 elements	EN 61158-4-18	2012
IEC 61158-4-18	2010	Industrial communication networks - Fieldbus specifications -- Part 4-18: Data- link layer protocol specification - Type 18 elements	EN 61158-4-18	2012
IEC 61158-4-19	2014	Industrial communication networks - Fieldbus specifications - Part 4-19: Data- link layer protocol specification - Type 19 elements	EN 61158-4-19	2014
IEC 61158-4-20	2014	Industrial communication networks - Fieldbus specifications - Part 4-20: Data- link layer protocol specification - Type 20 elements	EN 61158-4-20	2014
IEC 61158-4-24	2014	Industrial communication networks - Fieldbus specifications - Part 4-24: Data- link layer protocol specification - Type 24 elements	EN 61158-4-24	2014

IEC 61158-5-2	2014	Industrial communication networks - Fieldbus specifications -- Part 5-2: Application layer service definition - Type 2 elements	EN 61158-5-2	2014
IEC 61158-5-3	2014	Industrial communication networks - Fieldbus specifications - Part 5-3: Application layer service definition - Type 3 elements	EN 61158-5-3	2014
IEC 61158-5-4	2014	Industrial communication networks - Fieldbus specifications - Part 5-4: Application layer service definition - Type 4 elements	EN 61158-5-4	2014
IEC 61158-5-5	2014	Industrial communication networks - Fieldbus specifications - Part 5-5: Application layer service definition - Type 5 elements	EN 61158-5-5	2014
IEC 61158-5-7	2007	Industrial communication networks - Fieldbus specifications - Part 5-7: Application layer service definition - Type 7 elements	EN 61158-5-7	2008
IEC 61158-5-8	2007	Industrial communication networks - Fieldbus specifications - Part 5-8: Application layer service definition - Type 8 elements	EN 61158-5-8	2008
IEC 61158-5-9	2014	Industrial communication networks - Fieldbus specifications - Part 5-9: Application layer service definition - Type 9 elements	EN 61158-5-9	2014
IEC 61158-5-16	2007	Industrial communication networks - Fieldbus specifications - Part 5-16: Application layer service definition - Type 16 elements	EN 61158-5-16	2008
IEC 61158-5-18	2010	Industrial communication networks - Fieldbus specifications -- Part 5-18: Application layer service definition - Type 18 elements	EN 61158-5-18	2012
IEC 61158-5-19	2014	Industrial communication networks - Fieldbus specifications - Part 5-19: Application layer service definition - Type 19 elements	EN 61158-5-19	2014
IEC 61158-5-20	2014	Industrial communication networks - Fieldbus specifications - Part 5-20: Application layer service definition - Type 20 elements	EN 61158-5-20	2014
IEC 61158-5-24	2014	Industrial communication networks - Fieldbus specifications - Part 5-24: Application layer service definition - Type 24 elements	EN 61158-5-24	2014
IEC 61158-6-2	2014	Industrial communication networks - Fieldbus specifications - Part 6-2: Application layer protocol specification - Type 2 elements	FprEN 61158-6-2	2014
IEC 61158-6-3	2014	Industrial communication networks - Fieldbus specifications - Part 6-3: Application layer protocol specification - Type 3 elements	EN 61158-6-3	2014
IEC 61158-6-4	2014	Industrial communication networks - Fieldbus specifications - Part 6-4: Application layer protocol specification - Type 4 elements	EN 61158-6-4	2014

IEC 61158-6-5	2014	Industrial communication networks - Fieldbus specifications - Part 6-5: Application layer protocol specification - Type 5 elements	EN 61158-6-5	2014
IEC 61158-6-7	2007	Industrial communication networks - Fieldbus specifications - Part 6-7: Application layer protocol specification - Type 7 elements	EN 61158-6-7	2008
IEC 61158-6-8	2007	Industrial communication networks - Fieldbus specifications - Part 6-8: Application layer protocol specification - Type 8 elements	EN 61158-6-8	2008
IEC 61158-6-9	2014	Industrial communication networks - Fieldbus specifications - Part 6-9: Application layer protocol specification - Type 9 elements	EN 61158-6-9	2014
IEC 61158-6-16	2007	Industrial communication networks - Fieldbus specifications - Part 6-16: Application layer protocol specification - Type 16 elements	EN 61158-6-16	2008
IEC 61158-6-18	2010	Industrial communication networks - Fieldbus specifications - Part 6-18: Application layer protocol specification - Type 18 elements	EN 61158-6-18	2012
IEC 61158-6-19	2014	Industrial communication networks - Fieldbus specifications - Part 6-19: Application layer protocol specification - Type 19 elements	EN 61158-6-19	2014
IEC 61158-6-20	2014	Industrial communication networks - Fieldbus specifications - Part 6-20: Application layer protocol specification - Type 20 elements	EN 61158-6-20	2014
IEC 61158-6-24	2014	Industrial communication networks - Fieldbus specifications - Part 6-24: Application layer protocol specification - Type-24 Elements	EN 61158-6-24	2014
IEC 61784-2	2014	Industrial communication networks - Profiles - Part 2: Additional fieldbus profiles for real-time networks based on ISO/IEC 8802-3	EN 61784-2	2014
IEC 61784-5-2	2013	Industrial communication networks - Profiles -- Part 5-2: Installation of fieldbuses - Installation profiles for CPF 2	EN 61784-5-2	2013
IEC 61918 (mod)	2013	Industrial communication networks - Installation of communication networks in industrial premises	EN 61918	2013
IEC 62026-3	-	Low-voltage switchgear and controlgear Controller-device interfaces (CDIs) -- Part 3: Device Net	+AC +AA -	2014 201X -
IEC 62591	2010	Industrial communication networks - Wireless communication network and communication profiles - WirelessHART™	EN 62591	2010
ISO 15745-3	2003	Industrial automation systems and integration - Open systems application integration framework -- Part 3: Reference description for IEC 61158 based control systems	-	-

ISO 15745-4	2003	Industrial automation systems and integration - Open systems application integration framework - Part 4: Reference description for Ethernet-based control systems	-	-
ISO/IEC 8482	-	Information technology - Telecommunications and information exchange between systems - Twisted pair multipoint interconnections	-	-
ISO/IEC 8802-2	1998	Information technology - Telecommunications and information exchange between systems - Local and metropolitan area networks - Specific requirements -- Part 2: Logical link control	-	-
ISO/IEC 8802-3	2000	Information technology - Telecommunications and information exchange between systems - Local and metropolitan area networks - Specific requirements - Part 3: Carrier sense multiple access with collision detection (CSMA/CD) access method and physical layer specifications	-	-
ISO/IEC 15802-3	-	Information technology - Telecommunications and information exchange between systems - Local and metropolitan area networks - Common specifications - Part 3: Media Access Control (MAC) Bridges	-	-
ANSI TIA/EIA-485-A		Electrical Characteristics of Generators and Receivers for Use in Balanced Digital Multipoint Systems	-	-
IEEE 802.3	2002	Information technology - Telecommunications and information exchange between systems; Local and metropolitan area networks; Specific requirements - Part 3: Carrier sense multiple access with collision detection (CSMA/CD) access method and physical layer specifications	-	-
IETF RFC 1112	-	Host Extensions for IP Multicasting	-	-
IETF RFC 1122	-	Requirements for Internet Hosts - Communication Layers	-	-
IETF RFC 1123	-	Requirements for Internet Hosts - Application and Support	-	-
IETF RFC 1127	-	A Perspective on the Host Requirements RFCs	-	-
IETF RFC 2236	-	Internet Group Management Protocol	-	-
IETF RFC 768	-	User Datagram Protocol	-	-
IETF RFC 791	-	Internet Protocol - DARPA Internet Program Protocol Specification	-	-
IETF RFC 792	-	Internet Control Message Protocol	-	-
IETF RFC 793	-	Transmission Control Protocol - DARPA Internet Program Protocol Specification	-	-
IETF RFC 826	-	An Ethernet Address Resolution Protocol - or - Converting Network Protocol Addresses to 48.bit Ethernet Address for Transmission on Ethernet Hardware	-	-
IETF RFC 894	-	Standard for the Transmission of IP Datagrams over Ethernet Networks	-	-

CONTENTS

INTRODUCTION.....	17
1 Scope.....	18
2 Normative references	19
3 Definitions	23
3.1 Terms and definitions.....	23
3.2 Abbreviations and symbols	23
3.2.1 IEC 61158 abbreviations and symbols	23
3.2.2 Other abbreviations and symbols.....	24
3.3 Conventions.....	24
3.3.1 Conventions common to all layers	24
3.3.2 Physical layer	26
3.3.3 Data-link layer	26
3.3.4 Application layer	27
4 Conformance to communication profiles	27
5 Communication Profile Family 1 (FOUNDATION™ fieldbus)	28
5.1 General overview	28
5.2 Profile 1/1 (FOUNDATION™ H1)	29
5.2.1 Physical layer	29
5.2.2 Data-link layer	47
5.2.3 Application layer.....	118
5.3 Profile 1/2 (FOUNDATION™ HSE).....	120
5.3.1 Physical layer	120
5.3.2 Data-link layer	120
5.3.3 Network layer	120
5.3.4 Transport layer	120
5.3.5 Application layer	120
5.4 Profile 1/3 (FOUNDATION™ H2)	121
5.4.1 Physical layer	121
5.4.2 Data-link layer	124
5.4.3 Application layer	124
6 Communication Profile Family 2 (CIP™).....	124
6.1 General overview	124
6.2 Profile 2/1 (ControlNet)	125
6.2.1 Physical layer	125
6.2.2 Data-link layer	126
6.2.3 Application layer	128
6.3 Profile 2/2 (EtherNet/IP).....	129
6.3.1 Physical layer	129
6.3.2 Data-link layer	130
6.3.3 Application layer	131
6.4 Profile 2/3 (DeviceNet).....	133
6.4.1 Physical layer	133
6.4.2 Data-link layer	133
6.4.3 Application layer	135
7 Communication Profile Family 3 (PROFIBUS & PROFINET)	136

7.1	General overview	136
7.2	Profile 3/1 (PROFIBUS DP).....	138
7.2.1	Physical layer	138
7.2.2	Data-link layer	140
7.2.3	Application layer	164
7.3	Profile 3/2 (PROFIBUS PA).....	223
7.3.1	Physical layer	223
7.3.2	Data-link layer	228
7.3.3	Application layer	240
7.4	Profile 3/3 (PROFINET CBA)--- <i>Void</i>	241
8	Communication Profile Family 4 (P-NET®)	241
8.1	General overview	241
8.2	Profile 4/1 (P-NET RS-485).....	241
8.2.1	Physical layer	241
8.2.2	Data-link layer	242
8.2.3	Application layer	243
9	Communication Profile Family 5 (WorldFIP®)	244
9.1	General overview	244
9.2	Profile 5/1 (WorldFIP)	245
9.2.1	Physical layer	245
9.2.2	Data-link layer	247
9.2.3	Application layer	249
9.3	Profile 5/2 (WorldFIP)	255
9.3.1	Physical layer	255
9.3.2	Data-link layer	255
9.3.3	Application layer	255
9.4	Profile 5/3 (WorldFIP)	261
9.4.1	Physical layer	261
9.4.2	Data-link layer	261
9.4.3	Application layer	261
10	Communication Profile Family 6 (INTERBUS®)	262
10.1	General overview	262
10.2	Profile 6/1	263
10.2.1	Physical layer	263
10.2.2	Data-link layer	265
10.2.3	Application layer	267
10.3	Profile 6/2	268
10.3.1	Physical layer	268
10.3.2	Data-link layer	269
10.3.3	Application layer	270
10.4	Profile 6/3	271
10.4.1	Physical layer	271
10.4.2	Data-link layer	271
10.4.3	Application layer	272
11	Communication Profile Family 7 – <i>Void</i>	273
12	Communication Profile Family 8 (CC-Link).....	274
12.1	General overview	274
12.1.1	General	274

12.1.2	Profile 8/1	274
12.1.3	Profile 8/2	275
12.1.4	Profile 8/3	275
12.2	Profile 8/1	275
12.2.1	Physical layer	275
12.2.2	Data-link layer	276
12.2.3	Application layer	279
12.3	Profile 8/2	282
12.3.1	Physical layer	282
12.3.2	Data-link layer	282
12.3.3	Application layer	282
12.4	Profile 8/3	282
12.4.1	Physical layer	282
12.4.2	Data-link layer	283
12.4.3	Application layer	286
13	Communication Profile Family 9 (HART®)	289
13.1	General Overview	289
13.2	Profile 9/1, HART®	289
13.2.1	Physical layer	289
13.2.2	Data-link layer	290
13.2.3	Application layer	291
13.3	Profile 9/2, WirelessHART®	292
14	Communication Profile Family 16 (SERCOS)	292
14.1	General overview	292
14.2	Profile 16/1 (SERCOS I)	292
14.2.1	Physical layer selection	292
14.2.2	Data-link layer	293
14.2.3	Application layer	294
14.3	Profile 16/2 (SERCOS II)	294
14.3.1	Physical layer	294
14.3.2	Data-link layer	295
14.3.3	Application layer	296
15	Communication Profile Family 19 (MECHATROLINK)	296
15.1	General overview	296
15.2	Profile 19/1 (MECHATROLINK-II)	296
15.2.1	Physical layer selection	296
15.2.2	Data-link layer	298
15.2.3	Application layer	307
15.3	Profile 19/2 (M-III)	313
15.3.1	Physical layer	313
15.3.2	Data-link layer	313
15.3.3	Application layer	323
Annex A (informative) Communication concepts		328
A.1	CPF 1 (FOUNDATION Fieldbus) communication concepts	328
A.1.1	Overview	328
A.1.2	Physical layer characteristics	328
A.1.3	Data-link layer characteristics	328
A.1.4	Application layer characteristics	329

A.1.5	Management characteristics	329
A.2	CPF 2 (CIP) communication concepts.....	329
A.2.1	Overview.....	329
A.2.2	CIP common characteristics.....	330
A.2.3	ControlNet	330
A.2.4	EtherNet/IP	331
A.2.5	DeviceNet	332
A.3	CPF 3 (PROFIBUS & PROFINET) communication concepts	332
A.3.1	Basic characteristics	332
A.3.2	Physical layer profiles	333
A.3.3	Communication feature list (GSD).....	334
A.3.4	PROFINET---Void	334
A.4	CPF 4 (P-NET) communication concepts	334
A.5	CPF 5 (WorldFIP) communication concepts	336
A.5.1	Physical layer characteristics	336
A.5.2	Data-link layer characteristics	336
A.5.3	Application layer characteristics.....	336
A.6	CPF 6 (INTERBUS) communication concepts	336
A.7	CPF 8 (CC-LINK) communication concepts.....	338
A.7.1	Basic characteristics	338
A.7.2	Variants	338
A.8	CPF 9 (HART) communication concepts	339
A.9	CPF 16 (SERCOS) communication concepts	339
	Annex B (informative) Added value of IEC 61784-1.....	341
	Bibliography.....	342
	Figure 1 – Communication profile families and profiles	18
	Figure 2 – Example optical power budget for a 100/140 µm fiber system with a 16/16 optical passive star coupler.....	46
	Figure 3 – CP 3/2 Slave devices usable in applications.....	138
	Figure A.1 – Ring structure	339
	Figure A.2 – Topology example.....	340
	Table 1 – Relations of Communication Profile Families to type numbers	19
	Table 2 – Layout of profile (sub)clause selection tables	24
	Table 3 – Contents of (sub)clause selection tables	25
	Table 4 – Layout of service selection tables.....	25
	Table 5 – Contents of service selection tables	26
	Table 6 – Layout of parameter selection tables	26
	Table 7 – Contents of parameter selection tables	26
	Table 8 – Layout of class attribute selection tables	27
	Table 9 – Contents of class attribute selection tables.....	27
	Table 10 – CPF 1: overview of profile sets	29
	Table 11 – CP 1/1: PhL selection for communicating devices and their MAUs.....	29
	Table 12 – CP 1/1: PhL classification of MAUs and attached devices.....	31

Table 13 – CP 1/1: PhL selection of Clause 16 for devices and their MAUs	32
Table 14 – CP 1/1: PhL selection of Clause 12 for devices and their MAUs	32
Table 15 – Void	33
Table 16 – CP 1/1: PhL selection of recommended IS parameters for MAU classes 111, 112, 121, 122, 511 and 512	34
Table 17 – CP 1/1: PhL selection for media components.....	35
Table 18 – CP 1/1: PhL selection of imperative IS parameters for media in FISCO systems	36
Table 19 – CP 1/1: PhL selection for power supplies	37
Table 20 – CP 1/1: PhL selection of power supply types	38
Table 21 – CP 1/1: PhL selection of permissible output voltage and IS parameters for FISCO power supplies	38
Table 22 – CP 1/1: PhL selection for terminators	39
Table 23 – CP 1/1: PhL selection of IS parameters for terminators	40
Table 24 – CP 1/1: PhL selection of Clause 12 for intrinsic safety barriers	41
Table 25 – CP 1/1: PhL selection of recommended IS parameters for intrinsic safety barriers and galvanic isolators (Entity model only)	42
Table 26 – CP 1/1: PhL selection of Clause 12 for intrinsically safe galvanic isolators	43
Table 27 – CP 1/1: PhL selection of Clause 15, recommended optical fiber types	44
Table 28 – CP 1/1: PhL selection of passive star couplers, recommended maximum insertion loss	44
Table 29 – CP 1/1: PhL selection of active star couplers.....	45
Table 30 – CP 1/1: Optical power budget considerations	45
Table 31 – CP 1/1: DLL service selection.....	47
Table 32 – CP 1/1: DLL service selection of Clause 5.....	47
Table 33 – CP 1/1: DLL service selection of 5.4.....	47
Table 34 – CP 1/1: DLL service selection of 5.4.1	48
Table 35 – CP 1/1: DLL service selection of 5.4.3	48
Table 36 – CP 1/1: DLL service selection of 5.4.6	49
Table 37 – CP 1/1: DLL service selection of Clause 6.....	50
Table 38 – CP 1/1: DLL service selection of the summary of 6.3, DL-connection QoS.....	51
Table 39 – CP 1/1: DLL service selection of figures 9 to 14 of 6.4.....	51
Table 40 – CP 1/1: DLL service selection of 6.5.....	52
Table 41 – CP 1/1: DLL service selection: replacement for Table 13 of 6.5	53
Table 42 – CP 1/1: DLL service selection of 6.5, replacement for Table 14	54
Table 43 – CP 1/1: DLL service selection of 6.5 for use of addresses for peer DLC	54
Table 44 – CP 1/1: DLL service selection of 6.5 for use of addresses for multipeer DLC connect request at publisher	54
Table 45 – CP 1/1: DLL service selection of 6.5 for use of addresses for multipeer DLC connect request at subscriber	54
Table 46 – CP 1/1: DLL service selection of 6.6.....	55
Table 47 – CP 1/1: DLL service selection: replacement for Table 15 of 6.6	55
Table 48 – CP 1/1: DLL service selection of 6.7.....	56
Table 49 – CP 1/1: DLL service selection of 6.7, replacement for Table 16	56
Table 50 – CP 1/1: DLL service selection of 6.7, replacement for Table 17	56

Table 51 – CP 1/1: DLL service selection of 6.7, replacement for Table 18	57
Table 52 – CP 1/1: DLL service selection of Clause 7	57
Table 53 – CP 1/1: DLL service selection of 7.5, replacement for Table 23	58
Table 54 – CP 1/1: DLL service selection of Clause 8	59
Table 55 – CP 1/1: DLL service selection of 8.5, replacement for Table 28	59
Table 56 – CP 1/1: DLL protocol selection	60
Table 57 – CP 1/1: DLL protocol selection of Clause 4	60
Table 58 – CP 1/1: DLL protocol selection of 4.3	61
Table 59 – CP 1/1: DLL protocol selection of 4.3.2.1 for use of link designators	61
Table 60 – CP 1/1: DLL protocol selection of 4.3.2.2 for use of node designators	61
Table 61 – CP 1/1: DLL protocol selection of 4.3.3.1 for predefined flat non-local DL-addresses	62
Table 62 – CP 1/1: DLL protocol selection of 4.3.3.2 for predefined flat link-local DL-addresses	62
Table 63 – CP 1/1: DLL protocol selection of 4.3.3.3 for predefined node-local DL-addresses	62
Table 64 – CP 1/1: DLL protocol selection of 4.7	63
Table 65 – CP 1/1: DLL protocol selection of 4.7.4	64
Table 66 – CP 1/1: DLL protocol selection of 4.7.5	65
Table 67 – CP 1/1: DLL protocol selection of Clause 6	66
Table 68 – CP 1/1: DLL protocol selection, replacement for Table 10 of 6.0	67
Table 69 – CP 1/1: DLL protocol selection of 6.5	68
Table 70 – CP 1/1: DLL protocol selection of 6.7	71
Table 71 – CP 1/1: DLL protocol selection of 6.8	75
Table 72 – CP 1/1: DLL protocol selection of 6.11	76
Table 73 – CP 1/1: DLL protocol selection of 6.12	76
Table 74 – CP 1/1: DLL protocol selection of 6.15	77
Table 75 – CP 1/1: DLL protocol selection of 6.20	78
Table 76 – CP 1/1: DLL protocol selection of Clause 7	79
Table 77 – CP 1/1: DLL protocol selection of 7.4	80
Table 78 – CP 1/1: DLL protocol selection of Clause 8	81
Table 79 – CP 1/1: DLL protocol selection of 8.2	82
Table 80 – CP 1/1: DLL protocol selection of 8.2.2	93
Table 81 – CP 1/1: DLL protocol selection of 8.3	105
Table 82 – CP 1/1: DLL protocol selection of 8.4	106
Table 83 – CP 1/1: DLL protocol selection of Clause 9	107
Table 84 – CP 1/1: DLL protocol selection of 9.3	108
Table 85 – CP 1/1: DLL protocol selection of 9.3.5	110
Table 86 – CP 1/1: DLL protocol selection of 9.3.5.2.2, replacement for element encoding	111
Table 87 – CP 1/1: DLL protocol selection of Clause 10	111
Table 88 – CP 1/1: DLL protocol selection of 10.2	112
Table 89 – CP 1/1: DLL protocol selection of 10.3	113
Table 90 – CP 1/1: DLL protocol selection of 10.3.7, specification of errors	115

Table 91 – CP 1/1: DLL protocol selection of 10.4	116
Table 92 – CP 1/1: DLL protocol selection of 10.5	117
Table 93 – CP 1/1: DLL protocol selection of 10.6	118
Table 94 – CP 1/1: AL service selection.....	118
Table 95 – CP 1/1: AL data type selection of Clause 4.....	119
Table 96 – CP 1/1: AL protocol selection	119
Table 97 – CP 1/2: AL service selection.....	120
Table 98 – CP 1/2: AL protocol selection	121
Table 99 – CP 1/3: PhL selection for H2 devices.....	122
Table 100 – CP 1/3: PhL selection for H2 media and related components.....	123
Table 101 – CPF 2: overview of profile sets	125
Table 102 – CP 2/1: PhL selection	125
Table 103 – CP 2/1: DLL service selection.....	126
Table 104 – CP 2/1: DLL protocol selection	127
Table 105 – CP 2/1: DLL protocol selection of management objects	128
Table 106 – CP 2/1: AL service selection.....	128
Table 107 – CP 2/1: AL protocol selection	129
Table 108 – CP 2/2: DLL protocol selection	130
Table 109 – CP 2/2: DLL protocol selection of management objects	131
Table 110 – CP 2/2: AL service selection.....	131
Table 111 – CP 2/2: AL protocol selection	132
Table 112 – CP 2/3: DLL protocol selection	134
Table 113 – CP 2/3: DLL protocol selection of management objects	134
Table 114 – CP 2/3: AL service selection.....	135
Table 115 – CP 2/3: AL protocol selection	136
Table 116 – CPF 3: overview of profile sets	137
Table 117 – CP 3/1: PhL selection	138
Table 118 – CP 3/1: PhL selection of Clause 3	140
Table 119 – CP 3/1: PhL selection of Clause 4	140
Table 120 – CP 3/1: General DLL service selection	140
Table 121 – CP 3/1: DLL service selection for DP-V0 master (class 1).....	141
Table 122 – CP 3/1: DLM service selection for DP-V0 master (class 1).....	142
Table 123 – CP 3/1: DLL service selection for DP-V1 master (class 1).....	143
Table 124 – CP 3/1: DLM service selection for DP-V1 master (class 1).....	144
Table 125 – CP 3/1: DLL service selection for DP-V0 master (class 2).....	144
Table 126 – CP 3/1: DLL service selection for DP-V1 master (class 2).....	145
Table 127 – CP 3/1: DLL service selection for DP-V0 slave	147
Table 128 – CP 3/1: DLM service selection for DP-V0 slave	148
Table 129 – CP 3/1: DLL service selection for DP-V1 slave	149
Table 130 – CP 3/1: DLM service selection for DP-V1 slave	150
Table 131 – CP 3/1: General DLL protocol selection	151
Table 132 – CP 3/1: DLL protocol selection of Clause 5.....	151
Table 133 – CP 3/1: DLL protocol selection of Clause 6.....	152

Table 134 – CP 3/1: DLL protocol selection of Clause 7	152
Table 135 – CP 3/1: Time variable selection for DP-V0 master (class 1)	153
Table 136 – CP 3/1: Timer and counter selection for DP-V0 master (class 1)	154
Table 137 – CP 3/1: DLPDU selection for DP-V0 master (class 1)	154
Table 138 – CP 3/1: MAC state selection for DP-V0 master (class 1)	155
Table 139 – CP 3/1: Time selection for DP-V1 master (class 1)	156
Table 140 – CP 3/1: Timer and counter selection for DP-V1 master (class 1)	157
Table 141 – CP 3/1: DLPDU selection for DP-V1 master (class 1)	157
Table 142 – CP 3/1: MAC state selection for DP-V1 master (class 1)	158
Table 143 – CP 3/1: CS protocol selection for DP-V1 master (class 1)	158
Table 144 – CP 3/1: Time selection for DP-V1 master (class 2)	159
Table 145 – CP 3/1: Timer and counter selection for DP-V1 master (class 2)	159
Table 146 – CP 3/1: DLPDU selection for DP-V1 master (class 2)	160
Table 147 – CP 3/1: Time selection for DP-V0 slave	160
Table 148 – CP 3/1: Timer and counter selection for DP-V0 slave	161
Table 149 – CP 3/1: DLPDU selection for DP-V0 slave	161
Table 150 – CP 3/1: MAC state selection for DP-V0 slave	162
Table 151 – CP 3/1: Time selection for DP-V1 slave	162
Table 152 – CP 3/1: Timer and counter selection for DP-V1 slave	163
Table 153 – CP 3/1: DLPDU selection for DP-V1 slave	163
Table 154 – CP 3/1: CS protocol selection for DP-V1 slave	164
Table 155 – CP 3/1, 3/2: AL service selection	164
Table 156 – CP 3/1, 3/2: AL service selection of Clause 6	165
Table 157 – CP 3/1, 3/2: AL service selection of I/O data ASE	165
Table 158 – CP 3/1, 3/2: AL service selection of Diagnosis ASE	166
Table 159 – CP 3/1, 3/2: AL service selection of Context ASE	166
Table 160 – CP 3/1, 3/2: AL service selection of Management ASE	167
Table 161 – CP 3/1, 3/2: AL service selection of AR ASE	168
Table 162 – CP 3/1, 3/2: AL service selection of Clause 6	169
Table 163 – CP 3/1, 3/2: AL service selection of Process data ASE	169
Table 164 – CP 3/1, 3/2: AL service selection of I/O data ASE	170
Table 165 – CP 3/1, 3/2: AL service selection of Alarm ASE	170
Table 166 – CP 3/1, 3/2: AL service selection of Context ASE	170
Table 167 – CP 3/1, 3/2: AL service selection of Load region ASE	171
Table 168 – CP 3/1, 3/2: AL service selection of Function invocation ASE	171
Table 169 – CP 3/1, 3/2: AL service selection of Time ASE	171
Table 170 – CP 3/1, 3/2: AL service selection of AR ASE	172
Table 171 – CP 3/1, 3/2: AL service selection of Clause 6	173
Table 172 – CP 3/1, 3/2: AL service selection of I/O data ASE	173
Table 173 – CP 3/1, 3/2: AL service selection of Diagnosis ASE	174
Table 174 – CP 3/1, 3/2: AL service selection of Context ASE	174
Table 175 – CP 3/1, 3/2: AL service selection of Management ASE	175
Table 176 – CP 3/1, 3/2: AL service selection of AR ASE	175

Table 177 – CP 3/1, 3/2: AL service selection of Clause 6	176
Table 178 – CP 3/1, 3/2: AL service selection of Process data ASE	177
Table 179 – CP 3/1, 3/2: AL service selection of Context ASE	177
Table 180 – CP 3/1, 3/2: AL service selection of Load region ASE	178
Table 181 – CP 3/1, 3/2: AL service selection of Function invocation ASE	178
Table 182 – CP 3/1, 3/2: AL service selection of Time ASE	178
Table 183 – CP 3/1, 3/2: AL service selection of AR ASE	179
Table 184 – CP 3/1, 3/2: AL service selection of Clause 6	180
Table 185 – CP 3/1, 3/2: AL service selection of I/O data ASE	181
Table 186 – CP 3/1, 3/2: AL service selection of Diagnosis ASE	182
Table 187 – CP 3/1, 3/2: AL service selection of Context ASE	183
Table 188 – CP 3/1, 3/2: AL service selection of AR ASE	184
Table 189 – CP 3/1, 3/2: AL service selection of Clause 6	185
Table 190 – CP 3/1, 3/2: AL service selection of Process data ASE	185
Table 191 – CP 3/1, 3/2: AL service selection of I/O data ASE	186
Table 192 – CP 3/1, 3/2: AL service selection of diagnosis ASE	186
Table 193 – CP 3/1, 3/2: AL service selection of Alarm ASE	187
Table 194 – CP 3/1, 3/2: AL service selection of Context ASE	187
Table 195 – CP 3/1, 3/2: AL service selection of Load region ASE	188
Table 196 – CP 3/1, 3/2: AL service selection of Function invocation ASE	188
Table 197 – CP 3/1, 3/2: AL service selection of Time ASE	188
Table 198 – CP 3/1, 3/2: AL service selection of AR ASE	189
Table 199 – CP 3/1, 3/2: AL protocol selection	190
Table 200 – CP 3/1, 3/2: AL protocol selection of Clause 4 to 11	191
Table 201 – CP 3/1, 3/2: AL protocol selection of APDUs	193
Table 202 – CP 3/1, 3/2: AL protocol selection of FSPM services primitives	194
Table 203 – CP 3/1, 3/2: AL protocol selection of DMPM services primitives	195
Table 204 – CP 3/1, 3/2: AL protocol selection of Clause 4 to 11	196
Table 205 – CP 3/1, 3/2: AL protocol selection of APDUs	198
Table 206 – CP 3/1, 3/2: AL protocol selection of FSPM services primitives	199
Table 207 – CP 3/1, 3/2: AL protocol selection of DMPM services primitives	201
Table 208 – CP 3/1, 3/2: AL protocol selection of Clause 4 to 6	202
Table 209 – CP 3/1, 3/2: AL protocol selection of APDUs	204
Table 210 – CP 3/1, 3/2: AL protocol selection of FSPM services primitives	205
Table 211 – CP 3/1, 3/2: AL protocol selection of DMPM services primitives	205
Table 212 – CP 3/1, 3/2: AL protocol selection of Clause 4 to 11	206
Table 213 – CP 3/1, 3/2: AL protocol selection of APDUs	208
Table 214 – CP 3/1, 3/2: AL protocol selection of FSPM services primitives	210
Table 215 – CP 3/1, 3/2: AL protocol selection of DMPM services primitives	211
Table 216 – CP 3/1, 3/2: AL protocol selection of Clause 4 to 11	211
Table 217 – CP 3/1, 3/2: AL protocol selection of APDU selection	213
Table 218 – CP 3/1, 3/2: AL protocol selection of FSPM services primitives	214
Table 219 – CP 3/1, 3/2: AL protocol selection of DMPM services primitives	215

Table 220 – CP 3/1, 3/2: AL protocol selection of Clause 4 to 11	216
Table 221 – CP 3/1, 3/2: AL protocol selection of APDUs	218
Table 222 – CP 3/1, 3/2: AL protocol selection of FSPM services primitives	219
Table 223 – CP 3/1, 3/2: AL protocol selection of DMPM services primitives.....	221
Table 224 – CP 3/2: PhL selection	224
Table 225 – CP 3/2: PhL selection of Clause 12 for devices and their MAUs.....	226
Table 226 – CP 3/2: PhL selection of recommended IS parameters	227
Table 227 – CP 3/2: PhL selection of Clause 21 for devices and their MAUs.....	228
Table 228 – CP 3/2: General DLL protocol selection	229
Table 229 – CP 3/2: DLL protocol selection of Clause 4.....	229
Table 230 – CP 3/2: DLL protocol selection of Clause 5.....	230
Table 231 – CP 3/2: DLL protocol selection of Clause 6.....	230
Table 232 – CP 3/2: DLL protocol selection of Clause 7	231
Table 233 – CP 3/2: Time variable selection for DP-V0 master (class 1).....	232
Table 234 – CP 3/2: Timer and counter selection for DP-V0 master (class 1).....	232
Table 235 – CP 3/2: DLPDU selection for DP-V0 master (class 1)	233
Table 236 – CP 3/2: Time variable selection for DP-V1 master (class 1).....	234
Table 237 – CP 3/2: Timer and counter selection for DP-V1 master (class 1).....	235
Table 238 – CP 3/2: DLPDU selection for DP-V1 master (class 1)	235
Table 239 – CP 3/2: Time variable selection for DP-V1 master (class 2).....	236
Table 240 – CP 3/2: Timer and counter selection for DP-V1 master (class 2).....	237
Table 241 – CP 3/2: DLPDU selection for DP-V1 master (class 2)	237
Table 242 – CP 3/2: Time variable selection for DP-V0 slave	238
Table 243 – CP 3/2: Timer and counter selection for DP-V0 slave	238
Table 244 – CP 3/2: DLPDU selection for DP-V0 slave	239
Table 245 – CP 3/2: Time variable selection for DP-V1 slave.....	239
Table 246 – CP 3/2: Timer and counter selection for DP-V1 slave	240
Table 247 – CP 3/2: DLPDU selection for DP-V1 slave	240
Table 248 – CP 4/1: PhL selection	242
Table 249 – CP 4/1: DLL service selection.....	243
Table 250 – CP 4/1: DLL protocol selection	243
Table 251 – CP 4/1: AL service selection.....	244
Table 252 – CP 4/1: AL protocol selection	244
Table 253 – CPF 5: overview of profile sets	245
Table 254 – CPF 5: PhL selection.....	246
Table 255 – CPF 5: DLL service selection	247
Table 256 – CPF 5: DLL service selection of Clause 4.....	247
Table 257 – CPF 5: DLL protocol selection	248
Table 258 – CPF 5: DLL protocol selection of variables and resources	248
Table 259 – CPF 5: DLL protocol selection of DLPDUs.....	249
Table 260 – CP 5/1: AL service selection.....	249
Table 261 – CP 5/1: AL service selection of ASEs	250
Table 262 – CPF 5: AL service selection of MPS ASEs.....	250

Table 263 – CPF 5: AL service selection of variable elements	250
Table 264 – CPF 5: AL service selection of produced variable elements	251
Table 265 – CPF 5: AL service selection of consumed variable elements.....	251
Table 266 – CP 5/1: AL service selection of MPS services.....	251
Table 267 – CP 5/1, 5/2: AL service selection of A_Readloc service parameters	251
Table 268 – CP 5/1, 5/2: AL service selection of A_Readfar service parameters	252
Table 269 – CP 5/1, 5/2: AL service selection of A_Read service parameters	252
Table 270 – CP 5/1: AL service selection of MCS service classes.....	252
Table 271 – CP 5/1: AL service selection of QoS	252
Table 272 – CP 5/1: AL service selection of MCS services	253
Table 273 – CP 5/1, 5/2: AL service selection of A_Data parameters	253
Table 274 – CP 5/1: AL protocol selection	253
Table 275 – CPF 5/1: AL protocol selection of MPS data types	253
Table 276 – CPF 5/1: AL protocol selection of MPS PDUs	254
Table 277 – CPF 5/1: AL protocol selection of MPS encoding rules	254
Table 278 – CP 5/1, 5/2: AL protocol selection of MCS PDUs	254
Table 279 – CP 5/1: AL protocol selection of MCS state machines.....	255
Table 280 – CP 5/2: AL service selection.....	255
Table 281 – CP 5/2: AL service selection of ASEs	256
Table 282 – CP 5/2: AL service selection of MPS services.....	256
Table 283 – CP 5/2: AL service selection of MCS service classes.....	256
Table 284 – CP 5/2: AL service selection of QoS	257
Table 285 – CP 5/2: AL service selection of MCS services	257
Table 286 – CP 5/2: AL service selection of domain services.....	257
Table 287 – CP 5/2: AL service selection of domain object attributes.....	258
Table 288 – CP 5/2: AL service selection of program services	258
Table 289 – CP 5/2: AL service selection of program object attributes	258
Table 290 – CP 5/2: AL service selection of variable services.....	259
Table 291 – CP 5/2: AL service selection of variable classes	259
Table 292 – CP 5/2: AL service selection of variable class attributes	259
Table 293 – CP 5/2: AL protocol selection	259
Table 294 – CP 5/2: AL protocol selection of MCS state machines.....	260
Table 295 – CP 5/2: AL protocol selection of sub-MMS coding rules	260
Table 296 – CP 5/2: AL protocol selection of sub-MMS PDUs	261
Table 297 – CP 5/3: AL service selection.....	261
Table 298 – CP 5/3: AL service selection of ASEs	262
Table 299 – CP 5/3: AL protocol selection	262
Table 300 – CPF 6: device CP identifier assignment.....	263
Table 301 – CPF 6: PhL selection.....	264
Table 302 – CP 6/1: DLL service selection, assignment of DLL services to device types.....	266
Table 303 – CPF 6: DLL protocol selection of data widths supported by master	267
Table 304 – CP 6/1: AL service selection, assignment of AL services to device types.....	268
Table 305 – CP 6/2: DLL service selection, assignment of DLL services to device types.....	269

Table 306 – CP 6/2: AL service selection, assignment of AL services to device types.....	270
Table 307 – CP 6/2: AL service selection of AR-Data-Send-Acknowledge service parameters	271
Table 308 – CP 6/3: DLL service selection, assignment of DLL services to device types.....	272
Table 309 – CP 6/3: AL service selection, assignment of AL services to device types.....	273
Table 310 – CP 8/1 transmission support level	275
Table 311 – CP 8/1 PhL selection	276
Table 312 – CP 8/1 DLL services selection	277
Table 313 – CP 8/1 DLL protocol selection	278
Table 314 – CP 8/1 AL services selection	280
Table 315 – CP 8/1 AL protocol selection	281
Table 316 – CP 8/2 DLL protocol selection	282
Table 317 – CP 8/3 PhL selection	283
Table 318 – CP 8/3 DLL services selection	284
Table 319 – CP 8/3 DLL protocol selection	285
Table 320 – CP 8/3 AL services selection	287
Table 321 – CP 8/3 AL protocol selection	288
Table 322 – CP 9/1 PhL selection	290
Table 323 – CP 9/1: DLL service selection.....	291
Table 324 – CP 9/1: DLL protocol selection	291
Table 325 – CP 9/1: AL service selection.....	291
Table 326 – CP 9/1: AL protocol selection	292
Table 327 – CP 16/1: PhL selection	293
Table 328 – CP 16/1: DLL protocol selection	294
Table 329 – CP 16/1: AL service selection.....	294
Table 330 – CP 16/2: PhL selection	295
Table 331 – CPF 19: overview of profile sets	296
Table 332 – CP 19/1 profile: PhL selection	297
Table 333 – CP 19/1: DLL service selection.....	298
Table 334 – DLL service selection for C1 master of CP 19/1.....	299
Table 335 – DLL service selection for C2 master of CP 19//1.....	300
Table 336 – DLL service selection for slave of CP 19//1.....	301
Table 337 – CP 19/1: DLL protocol selection	302
Table 338 – DLL protocol selection for C1 master of CP 19/1	304
Table 339 – DLL protocol selection for C2 master of CP 19/1	305
Table 340 – DLL protocol selection for slave of CP 19/1	306
Table 341 – CP 19/1: AL service selection.....	308
Table 342 – Class selection for C1 master of CP 19/1	309
Table 343 – Master class attribute selection for C1 master of CP 19/1.....	309
Table 344 – Master class service selection	309
Table 345 – FDCMaster-AR class attribute selection for C1 master of CP 19/1.....	309
Table 346 – FDCMaster-AR class service selection	310
Table 347 – Class selection for C2 master of CP 19/1	310

Table 348 – Monitor class attribute selection for C2 master of CP 19/1	310
Table 349 – Monitor class service selection	310
Table 350 – FDCMonitor-AR class attribute selection for C2 master of CP 19/1	311
Table 351 – FDCMonitor-AR class service selection	311
Table 352 – Class selection for slave AP of CP 19/1	311
Table 353 – Slave class attribute selection for slave AP of CP 19/1	312
Table 354 – Slave class service selection	312
Table 355 – FDCSlave-AR class attribute selection for slave AP of CP 19/1	312
Table 356 – FDCSlave-AR class service selection	312
Table 357 – CP 19/1: AL protocol selection	312
Table 358 – CP 19/2: DLL service selection	313
Table 359 – DLL service selection for C1 master of CP 19/2	315
Table 360 – DLL service selection for C2 master of CP 19/2	316
Table 361 – DLL service selection for slave of CP 19/2	316
Table 362 – CP 19/2: DLL protocol selection	317
Table 363 – DLL protocol selection for C1 master of CP 19/2	319
Table 364 – DLL protocol selection for C2 master of CP 19/2	320
Table 365 – DLL protocol selection for slave of CP 19/2	322
Table 366 – CP 19/2: AL service selection	323
Table 367 – Class selection for C1 master of CP 19/2	324
Table 368 – EventManager class attribute selection for C1 master of CP 19/2	324
Table 369 – EventManager class service selection	324
Table 370 – Class selection for C2 master of CP 19/2	325
Table 371 – EventManager class attribute selection for C2 master of CP 19/2	325
Table 372 – EventManager class service selection	325
Table 373 – Class selection for slave AP of CP 19/2	326
Table 374 – EventManager class attribute selection for slave AP of CP 19/2	326
Table 375 – EventManager class service selection	326
Table 376 – CP 19/2: AL protocol selection	327
Table A.1 – Number of devices per CP16/1 and CP16/2 systems (examples)	340

INTRODUCTION

This part of IEC 61784 provides a set of Communication Profiles (CP) in the sense of ISO/IEC TR 10000-1. These answer the need of identifying the protocol families co-existing within the IEC 61158 series, as a result of the international harmonization of fieldbus technologies available on the market. More specifically, these profiles help to correctly state the compliance to the IEC 61158 series, and to avoid the spreading of divergent implementations, which would limit its use, clearness and understanding. Additional profiles to address specific market concerns, such as functional safety or information security, may be addressed by future parts of this standard.

This standard contains several Communication Profile Families (CPF), which specify one or more communication profiles. Such profiles identify, in a strict sense, protocol subsets of the IEC 61158 series via protocol specific communication profiles. They do not define device-type-specific communication profiles for the purpose of guiding manufacturers in feature set selection – for example, in selecting the minimum set of communication services and protocol to implement a specific class of devices, such as generic slaves or transmitters ("implementation profiles"). Neither do they define device profiles that specify communication profiles together with application functions needed to answer the need of a specific application ("application profiles").

It is agreed that these latter classes of profiles would help the use of the IEC 61158 series of standards; the profiles defined in this document are a necessary step to achieve that task.

It is also important to clarify that interoperability – defined as the ability of two or more network systems to exchange information and to make mutual use of the information that has been exchanged (see 3.2.1 of ISO/IEC TR 10000-1) – can be directly achieved on the same link only for those devices complying to the same communication profile.

Profiles contained in this International Standard are constructed of references to IEC 61158-2 and the IEC 61158-3, IEC 61158-4, IEC 61158-5 and IEC 61158-6 series, and other IS, TS or worldwide-accepted standards, as appropriate¹. Each profile is required to reference at least one (sub)part of IEC 61158-2 through IEC 61158-6.

Two or more Profiles, which are related to a common family, are specified within a "Communication Profile Family" (CPF).

¹ International Standardised Profiles may contain normative references to specifications other than International Standards; see ISO/IEC JTC 1 N 4047.

INDUSTRIAL COMMUNICATION NETWORKS – PROFILES –

Part 1: Fieldbus profiles

1 Scope

This part of IEC 61784 defines a set of protocol specific communication profiles based primarily on the IEC 61158 series, to be used in the design of devices involved in communications in factory manufacturing and process control.

Each profile selects specifications for the communications protocol stack at a device. It contains a minimal set of required services at the application layer and specification of options in intermediate layers defined through references. If no application layer is included, then a minimal set of required services at the Data-link layer is specified. The appropriate references to the protocol specific types are given in each communication profile family or associated profiles.

NOTE All profiles are based on standards or draft standards or International Standards published by the IEC or from standards or International Standards established by other standards bodies or open standards processes.

The structure of communication profile families is specified in Figure 1.

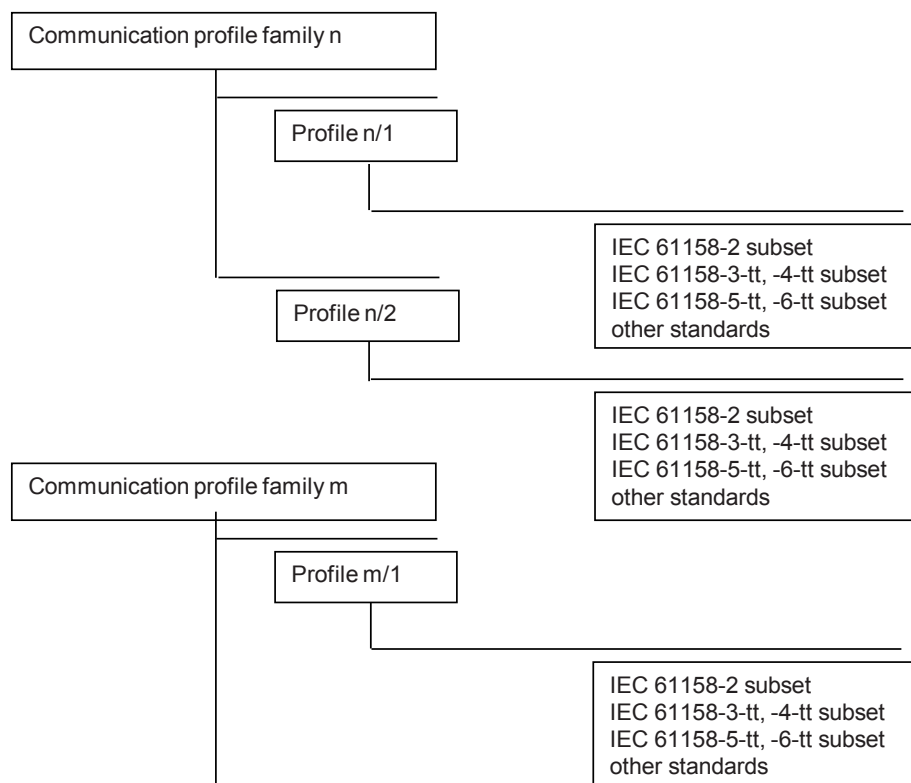

Figure 1 – Communication profile families and profiles

Each profile selects an appropriate consistent and compatible subset of services and protocols from the total available set that is defined and modeled in IEC 61158. For the

selected subset of services and protocols, the profile also describes any possible or necessary constraints in parameter values.

Table 1 shows the communication profile families that are defined in this standard.

Table 1 – Relations of Communication Profile Families to type numbers

IEC 61784-1 contents			Corresponding IEC 61158 Types
CPF	Clause	Communication Profile Families (Note 1)	Type
1	5	Foundation® Fieldbus	1, 5, 9 (see Note 2)
2	6	CIP™	2
3	7	PROFIBUS & PROFINET	3 (see Note 3)
4	8	P-NET®	4
5	9	WorldFIP®	7
6	10	INTERBUS®	8
7	11	Has been removed based for lack of market relevance	6
8	12	CC-Link	18
9	13	HART	20
16	14	SERCOS	16
19	15	MECHATROLINK	24

NOTE 1 See the specific CPF clauses for information on the respective trademark holders.

NOTE 2 CP 1/1 has a denigrated PhL device profile subclass, which uses a variant of a Type 3 PhL.

NOTE 3 CP 3/2 has a denigrated PhL device profile subclass, which uses a variant of a Type 1 PhL.

NOTE 4 Other CPFs can be found in IEC 61784-2.

2 Normative references

The following documents, in whole or in part, are normatively referenced in this document and are indispensable for its application. For dated references, only the edition cited applies. For undated references, the latest edition of the referenced document (including any amendments) applies.

NOTE All parts of the IEC 61158 series, as well as IEC 61784-1 and IEC 61784-2 are maintained simultaneously. Cross-references to these documents within the text therefore refer to the editions as dated in this list of normative references.

IEC 60079-11, *Explosive atmospheres – Part 11: Equipment protection by intrinsic safety "i"*

IEC 60079-25, *Explosive atmospheres – Part 25: Intrinsically safe electrical systems*

IEC 61010 (all parts), *Safety requirements for electrical equipment for measurement, control and laboratory use*

IEC 61131-2, *Programmable controllers – Part 2: Equipment requirements and tests*

IEC 61158 (all parts), *Industrial communication networks – Fieldbus specifications*

IEC 61158-2:2014, *Industrial communication networks – Fieldbus specifications – Part 2: Physical layer specification and service definition*

IEC 61158-3-1:2014, *Industrial communication networks – Fieldbus specifications – Part 3-1: Data-link layer service definition – Type 1 elements*

IEC 61158-3-2:2014, *Industrial communication networks – Fieldbus specifications – Part 3-2: Data-link layer service definition – Type 2 elements*

IEC 61158-3-3:2014, *Industrial communication networks – Fieldbus specifications – Part 3-3: Data-link layer service definition – Type 3 elements*

IEC 61158-3-4:2014, *Industrial communication networks – Fieldbus specifications – Part 3-4: Data-link layer service definition – Type 4 elements*

IEC 61158-3-7:2007, *Industrial communication networks – Fieldbus specifications – Part 3-7: Data-link layer service definition – Type 7 elements*

IEC 61158-3-8:2007, *Industrial communication networks – Fieldbus specifications – Part 3-8: Data-link layer service definition – Type 8 elements*

IEC 61158-3-16:2007, *Industrial communication networks – Fieldbus specifications – Part 3-16: Data-link layer service definition – Type 16 elements*

IEC 61158-3-18:2007, *Industrial communication networks – Fieldbus specifications – Part 3-18: Data-link layer service definition – Type 18 elements*

IEC 61158-3-19:2014, *Industrial communication networks – Fieldbus specifications – Part 3-19: Data-link layer service definition – Type 19 elements*

IEC 61158-3-20:2014, *Industrial communication networks – Fieldbus specifications – Part 3-20: Data-link layer service definition – Type 20 elements*

IEC 61158-3-24:2014, *Industrial communication networks – Fieldbus specifications – Part 3-24: Data-link layer service definition – Type 24 elements*

IEC 61158-4-1:2014, *Industrial communication networks – Fieldbus specifications – Part 4-1: Data-link layer protocol specification – Type 1 elements*

IEC 61158-4-2:2014, *Industrial communication networks – Fieldbus specifications – Part 4-2: Data-link layer protocol specification – Type 2 elements*

IEC 61158-4-3:2014, *Industrial communication networks – Fieldbus specifications – Part 4-3: Data-link layer protocol specification – Type 3 elements*

IEC 61158-4-4:2014, *Industrial communication networks – Fieldbus specifications – Part 4-4: Data-link layer protocol specification – Type 4 elements*

IEC 61158-4-7:2007, *Industrial communication networks – Fieldbus specifications – Part 4-7: Data-link layer protocol specification – Type 7 elements*

IEC 61158-4-8:2007, *Industrial communication networks – Fieldbus specifications – Part 4-8: Data-link layer protocol specification – Type 8 elements*

IEC 61158-4-16:2007, *Industrial communication networks – Fieldbus specifications – Part 4-16: Data-link layer protocol specification – Type 16 elements*

IEC 61158-4-18:2010, *Industrial communication networks – Fieldbus specifications – Part 4-18: Data-link layer protocol specification – Type 18 elements*

IEC 61158-4-19:2014, *Industrial communication networks – Fieldbus specifications – Part 4-19: Data-link layer protocol specification – Type 19 elements*

IEC 61158-4-20:2014, *Industrial communication networks – Fieldbus specifications – Part 4-20: Data-link layer protocol specification – Type 20 elements*

IEC 61158-4-24:2014, *Industrial communication networks – Fieldbus specifications – Part 4-24: Data-link layer protocol specification – Type 24 elements*

IEC 61158-5-2:2014, *Industrial communication networks – Fieldbus specifications – Part 5-2: Application layer service definition – Type 2 elements*

IEC 61158-5-3:2014, *Industrial communication networks – Fieldbus specifications – Part 5-3: Application layer service definition – Type 3 elements*

IEC 61158-5-4:2014, *Industrial communication networks – Fieldbus specifications – Part 5-4: Application layer service definition – Type 4 elements*

IEC 61158-5-5:2014, *Industrial communication networks – Fieldbus specifications – Part 5-5: Application layer service definition – Type 5 elements*

IEC 61158-5-7:2007, *Industrial communication networks – Fieldbus specifications – Part 5-7: Application layer service definition – Type 7 elements*

IEC 61158-5-8:2007, *Industrial communication networks – Fieldbus specifications – Part 5-8: Application layer service definition – Type 8 elements*

IEC 61158-5-9:2014, *Industrial communication networks – Fieldbus specifications – Part 5-9: Application layer service definition – Type 9 elements*

IEC 61158-5-16:2007, *Industrial communication networks – Fieldbus specifications – Part 5-16: Application layer service definition – Type 16 elements*

IEC 61158-5-18:2010, *Industrial communication networks – Fieldbus specifications – Part 5-18: Application layer service definition – Type 18 elements*

IEC 61158-5-19:2014, *Industrial communication networks – Fieldbus specifications – Part 5-19: Application layer service definition – Type 19 elements*

IEC 61158-5-20:2014, *Industrial communication networks – Fieldbus specifications – Part 5-20: Application layer service definition – Type 20 elements*

IEC 61158-5-24:2014, *Industrial communication networks – Fieldbus specifications – Part 5-24: Application layer service definition – Type 24 elements*

IEC 61158-6-2:2014, *Industrial communication networks – Fieldbus specifications – Part 6-2: Application layer protocol specification – Type 2 elements*

IEC 61158-6-3:2014, *Industrial communication networks – Fieldbus specifications – Part 6-3: Application layer protocol specification – Type 3 elements*

IEC 61158-6-4:2014, *Industrial communication networks – Fieldbus specifications – Part 6-4: Application layer protocol specification – Type 4 elements*

IEC 61158-6-5:2014, *Industrial communication networks – Fieldbus specifications – Part 6-5: Application layer protocol specification – Type 5 elements*

IEC 61158-6-7:2007, *Industrial communication networks – Fieldbus specifications – Part 6-7: Application layer protocol specification – Type 7 elements*

IEC 61158-6-8:2007, *Industrial communication networks – Fieldbus specifications – Part 6-8: Application layer protocol specification – Type 8 elements*

IEC 61158-6-9:2014, *Industrial communication networks – Fieldbus specifications – Part 6-9: Application layer protocol specification – Type 9 elements*

IEC 61158-6-16:2007, *Industrial communication networks – Fieldbus specifications – Part 6-16: Application layer protocol specification – Type 16 elements*

IEC 61158-6-18:2010, *Industrial communication networks – Fieldbus specifications – Part 6-18: Application layer protocol specification – Type 18 elements*

IEC 61158-6-19:2014, *Industrial communication networks – Fieldbus specifications – Part 6-19: Application layer protocol specification – Type 19 elements*

IEC 61158-6-20:2014, *Industrial communication networks – Fieldbus specifications – Part 6-20: Application layer protocol specification – Type 20 elements*

IEC 61158-6-24:2014, *Industrial communication networks – Fieldbus specifications – Part 6-24: Application layer protocol specification – Type 24 elements*

IEC 61784-2:2014, *Industrial communication networks – Profiles – Part 2: Additional fieldbus profiles for real-time networks based on ISO/IEC 8802-3*

IEC 61784-5-2:2013, *Industrial communication networks – Profiles – Part 5-2: Installation of fieldbuses – Installation profiles for CPF 2*

IEC 61918:2013, *Industrial communication networks – Installation of communication networks in industrial premises*

IEC 62026-3, *Low-voltage switchgear and controlgear – Controller-device interfaces (CDIs) – Part 3: DeviceNet*

IEC 62591:2010, *Industrial communication networks – Wireless communication network and communication profiles – WirelessHART™*

ISO/IEC 8482, *Information technology – Telecommunications and information exchange between systems – Twisted pair multipoint interconnections*

ISO/IEC 8802-2:1998, *Information technology – Telecommunications and information exchange between systems – Local and metropolitan area networks – Specific requirements – Part 2: Logical link control*

ISO/IEC 8802-3:2000, *Information technology – Telecommunications and information exchange between systems – Local and metropolitan area networks – Specific requirements – Part 3: Carrier sense multiple access with collision detection (CSMA/CD) access method and physical layer specifications*

ISO/IEC 15802-3, *Information technology – Telecommunications and information exchange between systems – Local and metropolitan area networks – Common specifications – Part 3: Media Access Control (MAC) Bridges*

ISO 15745-3:2003, *Industrial automation systems and integration – Open systems application integration framework – Part 3: Reference description for IEC 61158-based control systems*

ISO 15745-4:2003, *Industrial automation systems and integration – Open systems application integration framework – Part 4: Reference description for Ethernet-based control systems*, Amendment 1:2006, *PROFINET profiles*

ANSI TIA/EIA-485-A:1998, *Electrical Characteristics of Generators and Receivers for Use in Balanced Digital Multipoint Systems*

IEEE 802.3-2002, *IEEE Standard for Information technology – Telecommunications and information exchange between systems – Local and metropolitan area networks – Specific requirements – Part 3: Carrier Sense Multiple Access with Collision Detection (CSMA/CD) Access Method and Physical Layer Specifications*

IETF RFC 768, *User Datagram Protocol*; available at <<http://www.ietf.org>>

IETF RFC 791, *Internet Protocol*; available at <<http://www.ietf.org>>

IETF RFC 792, *Internet Control Message Protocol*; available at <<http://www.ietf.org>>

IETF RFC 793, *Transmission Control Protocol*; available at <<http://www.ietf.org>>

IETF RFC 826, *Ethernet Address Resolution Protocol*; available at <<http://www.ietf.org>>

IETF RFC 894, *A standard for the Transmission of IP Datagrams over Ethernet Networks*; available at <<http://www.ietf.org>>

IETF RFC 1112, *Host Extensions for IP Multicasting*; available at <<http://www.ietf.org>>

IETF RFC 1122, *Requirements for Internet Hosts – Communication Layers*; available at <<http://www.ietf.org>>

IETF RFC 1123, *Requirements for Internet Hosts – Application and Support*; available at <<http://www.ietf.org>>

IETF RFC 1127, *A Perspective on the Host Requirements RFCs*; available at <<http://www.ietf.org>>

IETF RFC 2236, *Internet Group Management Protocol, Version 2*; available at <<http://www.ietf.org>>

3 Definitions

3.1 Terms and definitions

For the purposes of this document, all terms and definitions provided in the IEC 61158 series apply.

3.2 Abbreviations and symbols

3.2.1 IEC 61158 abbreviations and symbols

For the purposes of this profile, all abbreviations and symbols defined in the IEC 61158 series apply. The following abbreviations, found within the IEC 61158 series, are repeated here for

use by those who wish to understand the general structure of this International Standard without referring to the IEC 61158 series.

AL	Application layer
APDU	Application protocol data unit
AR	Application relationship
ASE	Application service element
DL-	Data-link layer (as a prefix)
DLL	Data-link layer
DLSDU	Data-link service data unit
PhL	Physical layer
TPDU	Transport protocol data unit

3.2.2 Other abbreviations and symbols

CE	“Conformité Européene” (i.e., “European Conformity”)
CP	communication profile
CPF	communication profile family
DP-V0	PROFIBUS DP version 0
DP-V1	PROFIBUS DP version 1
EMC	electro-magnetic compatibility
IDN	identification number
IP	internet protocol
IS	intrinsically safe (as an adjective) intrinsic safety (as a noun)
ISP	international standardized profiles
IV	initialization vector
MAU	medium attachment unit
PPDU	presentation protocol data unit
RS 485	MAU according to ANSI TIA/EIA-485-A
RS 485-IS	MAU according to ANSI TIA/EIA-485-A and applicable to IS
TCP	terminal control protocol
UDP	user datagram protocol

3.3 Conventions

3.3.1 Conventions common to all layers

3.3.1.1 (Sub)clause selection tables

(Sub)clause selection for all layers is defined in tables, as shown in Table 2 and Table 3. The selected base specifications are indicated just before the selection table(s). Selection is done at the highest (sub)clause level possible to define the profile selection unambiguously.

Table 2 – Layout of profile (sub)clause selection tables

Clause	Header	Presence	Constraints

Table 3 – Contents of (sub)clause selection tables

Column	Text	Meaning
Clause	<#>	(sub)clause number of the base specifications
	Next clauses	any following clauses up to the last clause of the base specification
	Next Annexes	any following annexes up to the last annex of the base specification
Header	<text>	(sub)clause title of the base specifications
Presence	NO	This (sub)clause is not included in the profile
	YES	This (sub)clause is fully (100 %) included in the profile in this case no further detail is given
	—	Presence is defined in the following subclauses
	Partial	Parts of this (sub)clause is included in the profile
Constraints	See <#>	Constraints/remarks are defined in the given subclause, table or figure of this profile document
	—	No constraints other than given in the reference document (sub)clause, or not applicable
	<text>	The text defines the constraint directly, for longer text table footnotes or table notes may be used

If sequences of (sub)clauses do not match the profile, then the numbers are concatenated.

EXAMPLE 1 Concatenated subclauses

3.4 – 3.7	—	NO	—
-----------	---	----	---

EXAMPLE 2 Concatenated clauses up to the last clause

Next clauses	—	NO	—
--------------	---	----	---

EXAMPLE 3 concatenated annexes up to the last annex

Next annexes	—	NO	—
--------------	---	----	---

3.3.1.2 Service selection tables

If selection of services is defined in a table the format of Table 4 is used. The table identifies the selected services and includes service constraints, as explained in Table 5.

Table 4 – Layout of service selection tables

Service ref.	Service name	Usage	Constraint

Table 5 – Contents of service selection tables

Column	Text	Meaning
Service ref.	<#>	(sub)clause number of the base specifications where the service is defined
	—	Not applicable
Service name	<text>	The name of the service
Usage	M	Mandatory
	O	Optional
	—	Service is never used
Constraints	See <#>	Constraints/remarks are defined in the given subclause, table or figure of this profile document
	—	No constraints other than given in the reference document (sub)clause, or not applicable
	<text>	The text defines the constraint directly, for longer text table footnotes or table notes may be used

If selection of service parameters is defined in a table the format of Table 6 is used. Each table identifies the selected parameters and includes parameter constraints, as explained in Table 7.

Table 6 – Layout of parameter selection tables

Parameter ref.	Parameter name	Usage	Constraint

Table 7 – Contents of parameter selection tables

Column	Text	Meaning
Parameter ref.	<#>	(sub)clause number of the base specifications where the service is defined
	—	Not applicable
Parameter name	<text>	The name of the service parameter
Usage	M	Mandatory
	O	Optional
	—	Attribute is never present
Constraints	See <#>	Constraints/remarks are defined in the given subclause, table or figure of this profile document
	—	No constraints other than given in the reference document (sub)clause, or not applicable
	<text>	The text defines the constraint directly, for longer text table footnotes or table notes may be used

3.3.2 Physical layer

No additional conventions are defined.

3.3.3 Data-link layer

3.3.3.1 Service profile conventions

No additional conventions are defined.

3.3.3.2 Service and parameter selections

These are described using the common conventions, see 3.3.1.2.

3.3.4 Application layer

3.3.4.1 Service profile conventions

ASE and class selection is described using (sub)clause selection tables, see 3.3.1.1. If the usage of selected ASE and classes is further constrained this is specified in the profile (e.g. an optional item of the base standard is mandatory in the profile).

If selection of class attributes is defined in a table the format of Table 8 is used. The table identifies the selected class attributes and includes their constraints, as explained in Table 9.

Table 8 – Layout of class attribute selection tables

Attribute	Attribute Name	Usage	Constraint

Table 9 – Contents of class attribute selection tables

Column	Text	Meaning
Attribute	<#>	Attribute number of the base specification class
	—	Not applicable
Attribute Name	<text>	The name of the attribute
Usage	M	Mandatory
	O	Optional
	—	Attribute is never present
Constraints	See <#>	Constraints/remarks are defined in the given subclause, table or figure of this profile document
	—	No constraints other than given in the reference document (sub)clause, or not applicable
	<text>	The text defines the constraint directly, for longer text table footnotes or table notes may be used

3.3.4.2 Service and parameter selections

These are described using the common conventions, see 3.3.1.2.

4 Conformance to communication profiles

Each communication profile within this International Standard includes part of the IEC 61158 series. It may also include parts of other standards or international specifications.

A statement of compliance to a Communication Profile Family (CPF) of this International Standard shall be stated² as either

² In accordance with ISO/IEC Directives

Compliance to IEC 61784-1:2014³ CPF n <Type>

or

Compliance to IEC 61784-1 (Ed.4.0) CPF n <Type>

and a statement of compliance to a Communication Profile (CP) of this International Standard shall be stated as either

Compliance to IEC 61784-1:2014³ CP n/n <Type>

or

Compliance to IEC 61784-1 (Ed.4.0) CP n/n <Type>

where the Type within the angle brackets < > is optional and the angle brackets are not to be included.

Product Standards shall not include any Conformity Assessment aspects (including QM provisions), neither normative nor informative, other than provisions for product testing (evaluation and examination).

5 Communication Profile Family 1 (FOUNDATION™ fieldbus⁴)

5.1 General overview

Communication Profile Family 1 defines profiles based on IEC 61158-2, IEC 61158-3-1, IEC 61158-4-1 physical and data-link protocol Type 1, IEC 61158-5-9 and IEC 61158-6-9 application protocol Type 9, and IEC 61158-5-5 and IEC 61158-6-5 application protocol Type 5, and on other standards. (See Table 10.)

The FOUNDATION Fieldbus family of protocols consists primarily of two distinct protocol sets, known generically (for historical reasons) as H1 and HSE. The H1 profiles are a subset of IEC 61158 Type 1 physical and data-link and Type 9 application services and protocols, and include both wire-media and fiber-media physical layers operating at 31,25 kbit/s. The HSE profiles are based on use of the ISO/IEC 8802–3 (Ethernet-like) MAC and physical layers, and on use of standard internet network and transport layer protocols; they use the Type 5 application services and protocols.

A third profile set has been developed within the Fieldbus Foundation, but is not in current or planned use. It is included in this profile because it provides a migration path to CPF 1 from some of the CPF 5 protocols, and exclusion from this International Standard could inhibit that migration.

³ The date should not be used when the edition number is used.

⁴ FOUNDATION™ fieldbus is the trade name of the non-profit consortium “Fieldbus Foundation”. This information is given for the convenience of users of this document and does not constitute an endorsement by IEC of the trademark holder or any of its products. Compliance to this profile does not require use of the trade name Foundation Fieldbus. Use of the trade name Foundation Fieldbus requires permission of the trade name holder.

Table 10 – CPF 1: overview of profile sets

Layer	Profile 1/1 (H1)	Profile 1/2 (HSE)	Profile 1/3 (H2)
Application	IEC 61158-5-9, IEC 61158-6-9	IEC 61158-5-5, IEC 61158-6-5	IEC 61158-5-9, IEC 61158-6-9
Transport	—	RFC 768, RFC 793	—
Network	—	RFC 791	—
Data-link	IEC 61158-3-1, IEC 61158-4-1	ISO/IEC 8802-3, ISO/IEC 8802-2,	IEC 61158-3-1, IEC 61158-4-1
Physical	IEC 61158-2, 31,25 kbit/s, primarily Type 1	any of ISO/IEC 8802-3	Type 1 of IEC 61158-2

NOTE See Clause A.1 for an overview of FOUNDATION Fieldbus communications concepts.

5.2 Profile 1/1 (FOUNDATION™ H1)

5.2.1 Physical layer

5.2.1.1 Communicating devices

5.2.1.1.1 Introduction

Table 11 specifies the IEC 61158-2 PhL selection for a communicating device and its MAU(s).

Table 11 – CP 1/1: PhL selection for communicating devices and their MAUs

Clause	Header	Presence	Constraints
1	Scope	YES	—
2	Normative references	Partial	Used if needed
3	Terms and definitions	—	—
3.1	Common terms and definitions	Partial	Used when applicable
3.2	Type 1: Terms and definitions	YES	—
3.3 – 3.7	—	NO	—
4	Symbols and abbreviations	—	—
4.1	Symbols	—	—
4.1.1	Type 1: Symbols	YES	—
4.1.2 – 4.1.6	—	NO	—
4.2	Abbreviations	—	—
4.2.1	Type 1: Abbreviations	YES	—
4.2.2 – 4.2.6	—	NO	—
5	Data-link layer – Physical Layer interface	—	—
5.1	General	Partial	Used when applicable
5.2	Type 1: Required services	YES	—
5.3 – 5.7	—	NO	—
6	Systems Management – Physical Layer interface	—	—
6.1	General	Partial	Used when applicable
6.2	Type 1: Systems Management – Physical Layer interface	YES	—
6.3 – 6.7	—	NO	—
7	DCE Independent Sublayer (DIS)	—	—

Clause	Header	Presence	Constraints
7.1	General	Partial	Used when applicable
7.2	Type 1: DIS	YES	—
7.3 – 7.5	—	NO	—
8	DTE – DCE interface	—	—
8.1	General	Partial	Used when applicable
8.2	Type 1: DTE – DCE interface	YES	—
8.3 – 8.4	—	NO	—
9	Medium Dependent Sublayer (MDS)	—	—
9.1	General	Partial	Used when applicable
9.2	Type 1: MDS: Wire and optical media	YES	—
9.3 – 9.8	—	NO	—
10	MDS – MAU interface	—	—
10.1	General	Partial	Used when applicable
10.2	Type 1: MDS — MAU interface: wire and optical media	YES	—
10.3 – 10.6	—	NO	—
11	Type 1 and 7: Medium Attachment Unit: voltage mode, linear-bus-topology 150 Ω twisted-pair wire medium	NO	
12	Type 1 and 3: Medium Attachment Unit: 31,25 kbit/s, voltage-mode with low-power option, bus- and tree-topology, 100 Ω wire medium	YES	See 5.2.1.1.2
13 – 15	—	NO	—
16	Type 1: Medium Attachment Unit: 31,25 kbit/s, single-fiber optical medium	YES	See 5.2.1.1.2
17 – 20	—	NO	—
21	Type 3: Medium Attachment Unit: Synchronous transmission, 31,25 kbit/s, voltage mode, wire medium	YES	See 5.2.1.1.2 (denigrated)
Next clauses	—	NO	—
Annex A	Type 1: Connector specification	—	—
A.1	Internal Connector for wire medium	YES	^a
A.2	External Connectors for wire medium	YES	^a
A.3	External Connectors for optical medium	Partial	^b
Annex B	Type 1: Cable specifications and trunk and spur lengths for the 31,25 kbit/s voltage-mode MAU	YES	—
Annex C	Types 1 and 7: Optical passive stars	Partial	^b
Annex D	Types 1 and 7: Star topology	Partial	^b
Annex E	Type 1: Alternate fibers	Partial	^b
Next annexes	—	NO	—
^a Connector is optional for use with shielded or twisted-pair 100 Ω wire media.			
^b Single fiber specifications are optional for use with single fiber media.			

5.2.1.1.2 MAU and device classes

Each MAU is classified according to its characteristics when interfacing to its associated medium, as specified in Table 12. For devices with a single attached MAU, whether separate or integral, the MAU class is also considered to be the device class. The selection of the proper clause of IEC 61158-2, Clause 12 or Clause 16, is based on the MAU class for which the MAU, and sometimes the associated device, are designed. The selection of Clause 21 is

denigrated – not recommended for new designs – because the alternative clause, Clause 12, permits devices to lower their power consumption during periods of non-transmission.

This profile also lists recommendations, which are not mandatory for implementation and/or not specified in IEC 61158-2, but are included to achieve interoperability amongst devices conforming to this profile. Specifically, 5.2.1.1.3.3 applies to each MAU, as does 5.2.1.1.3.4 for MAUs meeting IS rules.

Table 12 – CP 1/1: PhL classification of MAUs and attached devices

Attribute	Attribute value	CP 1/1 MAU class										
		111	112	113	114	115	116			511	512	411
Connected medium	100 Ω shielded or twisted wire pair	X	X	X	X	X	X			X	X	
	Single bidirectional multimode fiber											X
Device powered from medium	Completely (see Note 2, 3)	X		X		X				X		
	Partially; not completely (see Note 2, 4)		X		X		X				X	
	Not at all											X
Intrinsic Safety construction rules	Not specified by this profile											X
	None			X	X							
	Entity model (see IEC 60079-11)	X	X									
	Energy Limited (Ex nL) or Nonincendive Field Wiring (NIFW)					X	X			X	X	
	FISCO model (see IEC 60079-11 and IEC 60079-25)											
Relevant MAU and device clause of IEC 61158-2	Clause 16 (see Table 13)											X
	Clause 12 (see Table 14)	X	X	X	X	X	X			X	X	
	Clause 21 (denigrated)											

NOTE 1 Low power signaling, optionally specified in Clause 12, is not included in any of these MAU types.

NOTE 2 Bus powered devices require a compatible power supply.

NOTE 3 The device does not contain a power supply, intrinsic safety barrier, galvanic isolator or terminator.

NOTE 4 The MAU needs to draw at least the equivalent of its transmit power from the medium to ensure a positive current on the medium throughout the transmit waveform (thereby keeping any polarity protection diodes in connected MAUs forward biased).

Table 13 – CP 1/1: PhL selection of Clause 16 for devices and their MAUs

Clause	Header	Presence	Constraints
16.1	General	YES	—
16.2	Transmitted bit rate	YES	—
16.3	Network specifications	NO	—
16.4	MAU transmit circuit specifications	YES	—
16.5	MAU receive circuit specifications	Partial	High-sensitivity only
16.6	Jabber inhibit	YES	—
16.7	Medium specifications	—	—
16.7.1	Connector	YES	ST or FC type connector
16.7.2	Standard test fiber	YES	The 1 m test fiber shall be used with a mode filter
16.7.3	Optical passive star	NO	—
16.7.4	Optical active star	NO	—

Table 14 – CP 1/1: PhL selection of Clause 12 for devices and their MAUs

Clause	Header	Presence	Constraints
12.1	General	YES	—
12.2	Transmitted bit rate	YES	—
12.3	Network specifications	NO	—
12.4	MAU transmit circuit specifications	YES	—
12.5	MAU receive circuit specifications	YES	See 5.2.1.1.3.2 for recommended receive filters
12.6	Jabber inhibit	YES	—
12.7	Power distribution	—	—
12.7.1	General	Partial	IEC 61158-2, Table 70, applies only to CP 1/1 device classes 121, 123 and 511. All else applies except IEC 61158-2, Table 71
12.7.2	Supply voltage	YES	—
12.7.3	Powered via signal conductors	YES	Applies only to CP 1/1 device classes 121, 123 and 511
12.7.4	Power supply impedance	NO	—
12.7.5	Powered separately from signal conductors	Partial	Applies only to CP 1/1 device class 122, 124 and 512, which do not require power on the bus. However, these devices shall be suitable for use on a powered bus. For example, a transformer-coupled device requires a DC-blocking capacitor in series with the transformer
12.7.6	Electrical isolation	YES	—
12.8	Medium specifications	—	—
12.8.1	Connector	YES	See 5.2.1.1.3.3 for labeling of the connector
12.8.2	Cable (standard test cable)	NO	—
12.8.3	Coupler	YES	—
12.8.4	Splices	NO	—
12.8.5	Terminator	NO	—
12.8.6	Shielding rules	NO	—
12.8.7	Grounding (earthing) rules	YES	—
12.9	Intrinsic safety	NO	See 5.2.1.1.3.4 for the IS device parameters for CP 1/1 device classes 121, 122, 511 and 512
12.10	Galvanic isolators	NO	—

Table 15 – Void**5.2.1.1.3 Recommended values for MAUs and their devices****5.2.1.1.3.1 Signal polarity**

The signal polarity for CP 1/1 MAU classes 111 to 114 shall be the signal polarity specified in IEC 61158-2, 12.4.5.

5.2.1.1.3.2 Receive filters

The receive filters for MAU classes 111 to 114, 121 to 124, 511 and 512 should be:

- a) 1 kHz 2-pole high pass, $0,6 \leq Q \leq 1,0$;
- b) 40 kHz 2-pole low pass, $0,6 \leq Q \leq 1,0$.

5.2.1.1.3.3 Labelling

The positive (“+”) and negative (“–”) terminals shall be clearly identified on all MAUs that:

- a) do not provide automatic polarity detection, and
- b) do not use the external connectors specified in IEC 61158-2, Clause A.2.

Each device incorporating an MAU shall be labelled with the MAUs CP 1/1 class. Where a device contains multiple MAUs, the labelling shall indicate the MAUs to which it (the labelling) applies.

The apparatus marking requirements of IEC 60079-11 apply to MAU classes 111 to 114, 121 to 124, 511 and 512. The apparatus marking requirements of IEC 60079-11 and IEC 60079-25 apply to MAU classes 511 and 512.

5.2.1.1.3.4 IS device parameters

From a communications standpoint, devices of any of the CP 1/1 classes can coexist on the same fieldbus segment. However, in IS applications, device power requirements and device and component approvals shall be taken into consideration.

NOTE Bus powered devices require a compatible power supply. See 5.2.1.2.2.

The recommended IS parameters for devices meeting Entity-model IS rules are listed in Table 16.

Table 16 – CP 1/1: PhL selection of recommended IS parameters for MAU classes 111, 112, 121, 122, 511 and 512

Parameter	Recommended values	
	Entity model	FISCO model
Applicable CP 1/1 devices classes	111, 112, 121, 122	511, 512
Device approval voltage	24 V minimum	17,5 V minimum
Device approval current	250 mA minimum	380 mA minimum
Device input power	1,2 W minimum	5,32 W minimum
Device residual capacitance	≤ 5 nF	≤ 5 nF
Device residual inductance	≤ 20 μH	≤ 10 μH
Leakage current	(not specified)	≤ 50 μA
IS classification	Ex ia, IIC (gas groups A & B), T4	Ex ia, IIC (gas groups A, B, C, D), T4 Ex ib, IIC (gas groups A, B, C, D), T4
Governing requirements	See IEC 60079-11	See IEC 60079-11 and IEC 60079-25

The CP 1/1 class 111, 112, 511 and 512 devices shall be designed to only sink power from the bus; i.e., these devices shall not source power to the bus. Since the CP 1/1 class 112 and 512 devices includes a separate source of power, extra precautions, such as galvanic isolation, may be required to prevent power transfer to the bus.

5.2.1.2 Wire media and related network components and considerations

5.2.1.2.1 Wire media

All components shall conform to IEC 61158-2 as shown in Table 17.

NOTE All wire media require termination. See 5.2.1.2.3.

Table 17 – CP 1/1: PhL selection for media components

Clause	Header	Presence	Constraints
1	Scope	YES	—
2	Normative references	Partial	Used if needed
3	Terms and definitions	—	—
3.1	Common terms and definitions	Partial	Used when applicable
3.2 – 3.7	—	NO	—
4 – 11	—	NO	—
12	Type 1 and 3: Medium Attachment Unit: 31,25 kbit/s, voltage-mode with low-power option, bus- and tree- topology, 100 Ω wire medium	—	—
12.1	General	YES	—
12.2	Network specifications	YES	This text contains important network configuration specifications
12.3 – 12.6	—	NO	—
12.8	—	NO	—
12.8.1	Connector	YES	—
12.8.2	Cable	YES	^b
12.8.3	Coupler	YES	—
12.8.4	Splices	YES	^b
12.8.5	—	NO	—
12.8.6	Shielding rules	YES	—
12.8.7	Grounding rules	YES	—
12.9 – 12.10	—	NO	—
Next clauses	—	NO	—
Annex A	Type 1: Connector specification	—	—
A.1	Internal Connector for wire medium	YES	^a
A.2	External Connectors for wire medium	YES	^a
A.3	—	NO	—
Next annexes	—	NO	—
^a The connector is optional.			
^b Networks and their components designed to meet FISCO IS rules shall also conform to Table 18.			

Table 18 – CP 1/1: PhL selection of imperative IS parameters for media in FISCO systems

Parameter	Minimum	Maximum in IIC application	Maximum in IIB application
Maximum trunk cable for IIC applications	0 km	1 km	5 km
Maximum spur cable for IIC applications	0 m	30 m	
Loop resistance	15 Ω /km	150 Ω /km	
Inductance	0,4 μ H / km	1 μ H / km	
Capacitance	80 nF / km	200 nF / km	
See IEC 60079-11 and IEC 60079-25.			

5.2.1.2.2 Power supplies

Unless specifically stated otherwise, it is assumed that a power supply does not contain a fieldbus device, terminator, Intrinsic safety barrier or galvanic isolator.

All power supplies shall conform to IEC 61158-2 as shown in Table 19.

Table 19 – CP 1/1: PhL selection for power supplies

Clause	Header	Presence	Constraints
1	Scope	YES	—
2	Normative references	Partial	Used if needed
3	Terms and definitions	—	—
3.1	Common terms and definitions	Partial	Used when applicable
3.2 – 3.7	—	NO	—
4 – 11	—	NO	—
12	Type 1 and 3: Medium Attachment Unit: 31,25 kbit/s, voltage-mode with low-power option, bus- and tree- topology, 100 Ω wire medium	—	—
12.1	General	YES	—
12.2	Network specifications	YES	This text contains important network configuration specifications
12.3 – 12.7	—	NO	—
12.7	Power distribution	—	—
12.7.1	General	YES	a, b
12.7.2	Supply voltage	YES	a
12.7.3	Powered via signal conductors	Partial	a, b
12.7.4	Power supply impedance	YES	a
12.7.5	—	NO	—
12.7.6	Electrical isolation	YES	a
12.8	Medium specifications	—	—
12.8.1	Connector	YES	c
12.8.2 – 12.8.4	—	NO	—
12.8.5	Terminator	Partial	a
12.8.6	—	NO	—
12.8.7	Grounding rules	Partial	Used when applicable
12.9 – 12.10	—	NO	—
Next clauses	—	NO	—
Annex A	Type 1: Connector specification	—	—
A.1	Internal Connector for wire medium	YES	c
A.2	External Connectors for wire medium	YES	c
A.3	—	NO	—
Next annexes	—	NO	—
<p>^a For power supplies designed to meet FISCO rules, in case of conflict, FISCO rules take precedence.</p> <p>^b Power supplies with multiple outputs shall comply with the transmit and receive waveform requirements of IEC 61158-2, 12.7, with regard to the signal transfer characteristics between their output ports, and with the requirements of IEC 61158-2, 12.7.4.3.</p> <p>^c The connector is optional.</p>			

A fieldbus power supply is categorized as defined in Table 20.

Table 20 – CP 1/1: PhL selection of power supply types

Power supply type	Output voltage	Description
Type 131	compatible with barrier	Non-IS power supply intended for feeding an entity model IS barrier
Type 132	≤ 32 V	Non-IS power supply not intended for feeding an IS barrier
Type 133	≤ 24 V	Entity model, IS power supply
Type 551	$\leq 14,0 - 17,5$ V ^a	FISCO Power Supply for Zone 0, Group IIC Gas applications, [Ex ia] IIC
Type 552	$\leq 14,0 - 17,5$ V ^a	FISCO Power Supply for Zone 0, Group IIB Gas applications, [Ex ia] IIB
Type 553	$\leq 14,0 - 17,5$ V ^a	FISCO Power Supply for Zone 2, Group IIC Gas applications, [Ex ic] IIC
Type 554	$\leq 14,0 - 17,5$ V ^a	FISCO Power Supply for Zone 2, Group IIB Gas applications, [Ex ic] IIB
^a The actual maximum output voltage is a function of the maximum rated current.		

Type 55, 552, 553 and 554 power supplies may

- be linear (resistance limited),
- have a trapezoidal (voltage limited) output characteristic, or
- have a rectangular (voltage and current limited) output characteristic.

The recommended output voltage and maximum IS parameters for a Type 551 or Type 552 power supply, which is intended to operate with devices of Types 511 or 512 or both, are listed in Table 21. A Type 551 or Type 552 power supply shall be separated from the nearest terminator, at an end of the trunk cable, by no more than 30 m of cable.

Table 21 – CP 1/1: PhL selection of permissible output voltage and IS parameters for FISCO power supplies

Parameter	Permissible values	
	Type 551 – IIC	Type 552 – IIB
Voltage	14,0 V to 17,5 V	
Maximum current		
at 14,0 V	183 mA	380 mA
at 15,0 V	133 mA	354 mA
at 16,0 V	103 mA	288 mA
at 17,0 V	81 mA	240 mA
at 17,5 V	75 mA	213 mA
Maximum output power	2,52 W	5,32 W
Maximum residual capacitance	5 nF	
Maximum residual inductance	10 μ H	
See IEC 60079-11 and IEC 60079-25.		

5.2.1.2.3 Terminators

It is assumed that the terminator does not contain a fieldbus MAU, power supply, intrinsic safety barrier or galvanic isolator.

All terminators shall conform to IEC 61158-2 as shown in Table 22.

Table 22 – CP 1/1: PhL selection for terminators

Clause	Header	Presence	Constraints
1	Scope	YES	—
2	Normative references	Partial	Used if needed
3	Terms and definitions	—	—
3.1	Common terms and definitions	Partial	Used when applicable
3.2 – 3.7	—	NO	—
4 – 11	—	NO	—
12	Type 1 and 3: Medium Attachment Unit: 31,25 kbit/s, voltage-mode with low-power option, bus- and tree-topology, 100 Ω wire medium	—	—
12.1	General	YES	—
12.2 – 12.6	—	NO	—
12.7	Power distribution	—	—
12.7.1	General	Partial	Does not include IEC 61158-2, Table 70 or Table 71
12.7.2 – 12.7.5	—	NO	—
12.7.6	Electrical isolation	YES	—
12.8	Medium	—	—
12.8.1	Connector	YES	—
12.8.2 – 12.8.4	—	NO	—
12.8.5	Terminator	YES	^a
12.8.6	—	NO	—
12.8.7	Grounding (earthing) rules	YES	—
12.9	Intrinsic safety	—	For intrinsically safe networks the network terminator will require appropriate approvals if installed in a hazardous area. See Table 23 for the IS parameters for a terminator intended for installation in a hazardous area
12.9.1	—	NO	—
12.9.2	Intrinsic safety barrier	YES	—
12.9.3	Barrier and terminator placement	YES	—
12.10	—	NO	—
Next clauses	—	NO	—
Annex A	Type 1: Connector specification	—	—
A.1	Internal Connector for wire medium	YES	^b
A.2	External Connectors for wire medium	YES	^b
Next annexes	—	NO	—
^a For terminators designed to meet FISCO IS rules, in case of conflict, FISCO rules take precedence.			
^b The connector is optional.			

Table 23 – CP 1/1: PhL selection of IS parameters for terminators

Parameter	Required values	
	Entity model	FISCO model
Mounting	Zone 0 (US Div. 1)	Zone 0 (US Div. 1)
Gas group	IIC (US Groups A & B)	IIC (US Groups A & B)
Device approval voltage	≥ 24 V	$\geq 17,5$ V
Device approval current	≥ 250 mA	≥ 380 mA
Device input power	$\geq 1,2$ W	$\geq 5,32$ W
Terminator residual inductance	≤ 20 μ H	≤ 10 μ H
IS classification	Ex ia, IIC (gas groups A & B), T4	Ex ia, IIC (gas groups A, B, C, D), T4 Ex ib, IIC (gas groups A, B, C, D), T4
Governing requirements	See IEC 60079-11	See IEC 60079-11 and IEC 60079-25

5.2.1.2.4 Intrinsic safety barriers

NOTE FISCO rules do not permit use of intrinsic safety barriers as separate components. See IEC 60079-11 and IEC 60079-25.

It is assumed that the intrinsic safety barrier does not contain a fieldbus MAU, terminator or power supply.

An Intrinsic safety barrier is used to communicate with devices and other network elements installed in a hazardous area. It should be suitably approved by relevant safety authorities for use in the intended application.

All Intrinsic safety barriers shall conform to IEC 61158-2, Clause 12, as shown in Table 24.

Table 24 – CP 1/1: PhL selection of Clause 12 for intrinsic safety barriers

Clause	Header	Presence	Constraints
1	Scope	YES	—
2	Normative references	Partial	Used if needed
3	Terms and definitions	—	—
3.1	Common terms and definitions	Partial	Used when applicable
3.2 – 3.7	—	NO	—
4 – 11	—	NO	—
12	Type 1 and 3: Medium Attachment Unit: 31,25 kbit/s, voltage-mode with low-power option, bus- and tree-topology, 100 Ω wire medium	—	—
12.1	General	YES	—
12.2	Transmitted bit rate	NO	—
12.3	Network specifications	NO	—
12.4	MAU transmit circuit specifications	YES	IS barriers shall comply with the transmit waveform requirements of the referenced subclause
12.5	MAU receive circuit specifications	YES	IS barriers shall comply with the receive waveform requirements of the referenced subclause
12.6	Jabber inhibit	NO	—
12.7	Power distribution	—	—
Table 70	Network powered device characteristics	NO	—
Table 71	Network power supply requirements	NO	—
12.7.1	General	NO	—
12.7.2	Supply voltage	NO	—
12.7.3	Powered via signal conductors	NO	—
12.7.4	Power supply impedance	—	—
12.7.4.1	Power supply impedance for single output power supplies	NO	—
12.7.4.2	Power distribution through an IS barrier	YES	—
12.7.4.3	Power supply impedance for multiple output supplies with signal coupling between outputs	NO	—
12.7.5	Powered separately from signal conductors	NO	—
12.7.6	Electrical isolation	YES	For system safety the network shall be grounded only at the IS barrier
12.8	Medium specifications	—	—
12.8.1	Connector	YES	^a
12.8.2-12.8.6		NO	—
12.8.7	Grounding rules	YES	For system safety the network shall be grounded only at the IS barrier
12.9	Intrinsic safety	YES	See Table 25 for the IS parameters for intrinsic safety barriers
12.10	Galvanic isolators	NO	—
Next clauses	—	NO	—
Annex A	Type 1: Connector specification	—	—

Clause	Header	Presence	Constraints
A.1	Internal Connector for wire medium	YES	^a
A.2	External Connectors for wire medium	YES	^a
Next annexes		NO	—
^a The connector is optional.			

Table 25 – CP 1/1: PhL selection of recommended IS parameters for intrinsic safety barriers and galvanic isolators (Entity model only)

Parameter	Value
Mounting	Zone 0 (US Div. 1)
Gas group	IIC (US Groups A & B)
Open circuit output voltage (see Note)	≤ 24 V
Short circuit output current	≤ 250 mA
Matched output power	≤ 1,2 W
NOTE The maximum working voltage of the barrier will be less than this value. The power supply voltage of the system is selected to be compatible with the working voltage.	

5.2.1.2.5 Galvanic isolators

NOTE FISCO rules do not permit use of galvanic isolators as separate components. See IEC 60079-11 and IEC 60079-25.

It is assumed that the Intrinsically safe galvanic isolator does not contain a fieldbus MAU, terminator or power supply.

An Intrinsically safe galvanic isolator is used to communicate with devices and other network elements installed in a hazardous area. It should be suitably approved by relevant safety authorities for use in the intended application.

All Intrinsically safe galvanic isolators shall conform to IEC 61158-2 as shown in Table 26.

Table 26 – CP 1/1: PhL selection of Clause 12 for intrinsically safe galvanic isolators

Clause	Header	Presence	Constraints
1	Scope	YES	—
2	Normative references	Partial	Used if needed
3	Terms and definitions	—	—
3.1	Common terms and definitions	Partial	Used when applicable
3.2 – 3.7	—	NO	—
4 – 11	—	NO	—
12	Type 1 and 3: Medium Attachment Unit: 31,25 kbit/s, voltage-mode with low-power option, bus- and tree-topology, 100 Ω wire medium	—	—
12.1	General	YES	—
12.2	Transmitted bit rate	NO	—
12.3	Network specifications	NO	—
12.4	Transmit circuit specifications	YES	Intrinsically safe galvanic isolator shall comply with the transmit waveform requirements of the referenced subclause
12.5	Receive circuit specifications	YES	Intrinsically safe galvanic isolator shall comply with the receive waveform requirements of the referenced subclause
12.6	Jabber inhibit	NO	—
12.7	Power distribution	—	—
12.7.1	General	YES	—
Table 70	Network powered device characteristics for the 31,25 kbit/s, voltage mode MAU	NO	—
Table 71	Network power supply requirements for the 31,25 kbit/s, voltage mode MAU	NO	—
12.7.2-12.7-5	—	NO	—
12.7.6	Electrical isolation	YES	Where a galvanic isolator includes one or more fieldbus power supplies these shall comply with the relevant conditions in 5.2.1.2.2
12.8	Medium specifications	—	—
12.8.1	Connector	YES	—
12.8.2-12.8.7	—	NO	—
12.9	Intrinsic safety	YES	See Table 25 for the IS parameters
12.10	Galvanic isolators	YES	—
Next clauses	—	NO	—
Annex A	Type 1: Connector specification	—	—
A.1	Internal Connector for wire medium	YES	^a
A.2	External Connectors for wire medium	YES	^a
Next annexes	—	NO	—
^a The connector is optional.			

5.2.1.3 Fiber media and related network components and considerations

5.2.1.3.1 Optical fiber types

The alternatives for optical fiber type for a Type 411 device are listed in Table 27.

Table 27 – CP 1/1: PhL selection of Clause 15, recommended optical fiber types

Fiber use	31,25 kbit/s single fiber	NA (numerical aperture)	Attenuation ($f = 850 \text{ nm}$)	Comments
Standard test fiber	100/140 μm (A1d)	$0,26 \pm 0,03$	$\leq 4,0 \text{ dB/km}$	Mode filter required
Recommended operating fiber	100/140 μm (A1d)	$0,26 \pm 0,03$	$\leq 4,0 \text{ dB/km}$	
	200/230 μm (A3c)	$0,4 \pm 0,04$	$\leq 10,0 \text{ dB/km}$	
	50/125 μm (A1a)	$0,2 \pm 0,02$	$\leq 3,0 \text{ dB/km}$	
	62,5/125 μm (A1b)	$0,275 \pm 0,015$	$\leq 3,0 \text{ dB/km}$	

NOTE For fiber types A1d, A3c, A1a and A1b, structure (SI or GI) and bandwidth, refer to IEC 60793, optical fiber specifications. For attenuation, bandwidth and numerical aperture (NA), refer to the test methods of IEC 60793.

5.2.1.3.2 Passive star couplers

The recommended maximum insertion losses for optical passive star couplers for the 31,25 kbit/s single-fiber optical medium are listed in Table 28. Reflective star couplers (see IEC 61158-2, Annex D) are required for the single-fiber medium.

Table 28 – CP 1/1: PhL selection of passive star couplers, recommended maximum insertion loss

	CP 1/1 class for passive star coupler	Number of branches					
		2	3	4	8	16	32
Recommended maximum insertion loss	CP 1/1 class 421 (100/140 μm (A1d))	7,0	9,0	10,5	14,5	17,5	21,5
	CP 1/1 class 422 (200/230 μm (A3c))	7,5	10,0	11,0	15,0	18,5	22,5
	CP 1/1 class 423 (50/125 μm (A1a))	7,0	9,0	10,5	14,5	18,0	22,0
	CP 1/1 class 424 (62,5/125 μm (A1b))	7,0	9,0	10,5	14,5	18,0	22,0

NOTE The insertion loss includes the loss due to two connectors.

5.2.1.3.3 Active star couplers

The characteristics for active star couplers for the 31,25 kbit/s, single-fiber optical medium are listed in Table 29.

Table 29 – CP 1/1: PhL selection of active star couplers

Parameter	CP 1/1 class 431 (with timing regeneration)	CP 1/1 class 432 (without timing regeneration)
	Recommended value	
Peak emission wavelength	850 ± 30 nm	
Typical half Intensity wavelength	≤ 50 nm	
Effective launch power Hi level (see Note)	–13,5 ± 1,0 dBm	
Receiver operating range	–40,0 dBm to –20,0 dBm	
Maximum received bit cell jitter	± 14 % nominal bit time	
Rise and fall times of transmitted signal	≤ 2,0 % nominal bit time	
Maximum temporal deformation	± 3,0 % nominal bit time	
Maximum transmitted bit cell jitter	± 2,0 % normal bit time	<not specified>
Propagation time	≤ 2,0 nominal bit times	<not specified>
Number of branches	≤ 32	

NOTE This is the power measured with a standard test fiber connected to a CPIC as defined in IEC 61158-2, 16.4 and 16.7.2.

5.2.1.3.4 Optical power budget

Optical power budget considerations are shown in Table 30, and an example optical power budget for a system is shown in Figure 2.

Table 30 – CP 1/1: Optical power budget considerations

Parameter	100/140 μm fiber system	200/230 μm fiber system	62,5/125 μm fiber system	50/125 μm fiber system
Launch power	–14,5 dBm	–8,0 dBm	–18,5 dBm	–21,5 dBm
Receiver sensitivity	–40 dBm	–40 dBm	–40 dBm	–40 dBm
Dynamic range	25,5 dB	31,0 dB	21,5 dB	18,5 dB
OPSC (Optical Passive Star Coupler) attenuation:				
(16/16 OPSC)	17,5 dB	18,5 dB	—	—
(8/8 OPSC)	—	—	14,5 dB	—
(4/4 OPSC)	—	—	—	10,5 dB
Attenuation margin	3 dB	6,5 dB	3 dB	3 dB
Attenuation of optical fiber cable	5 dB	6 dB	4 dB	5 dB
Maximum transmission distance:				
(16/16 OPSC)	1,25 km	0,6 km	—	—
(8/8 OPSC)	—	—	1,33 km	—
(4/4 OPSC)	—	—	—	1,66 km

NOTE OPSC attenuation measurements include loss from two connectors.

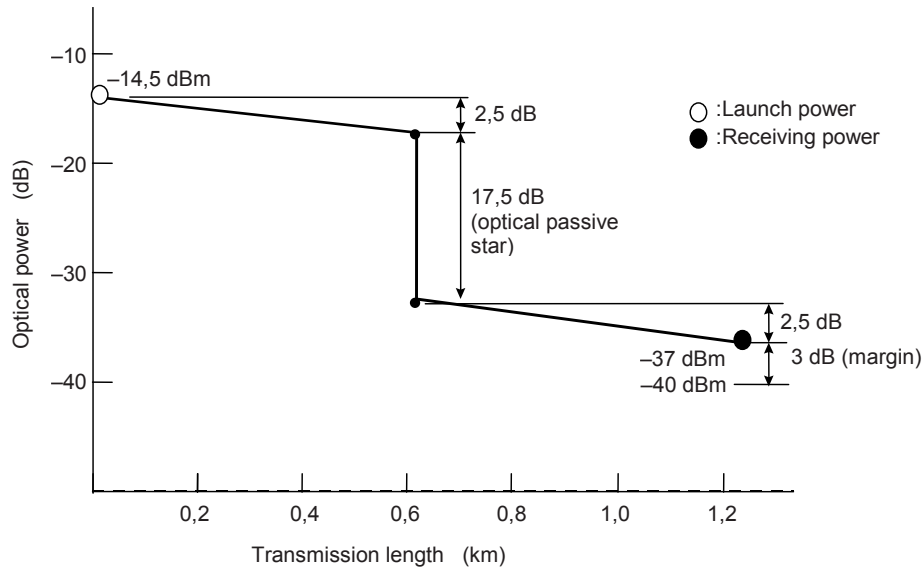

Figure 2 – Example optical power budget for a 100/140 μm fiber system with a 16/16 optical passive star coupler

5.2.1.4 Optical / electrical signaling converters

Active star couplers can have both optical-media and wire-media ports. CP 1/1 class 433 devices are active star couplers with timing regeneration with one or more wire-media ports. Their optical ports shall meet the specifications of CP 1/1 class 431 devices, while each of their electrical ports shall meet the relevant specifications of one of the following CP 1/1 device classes: 121, 122, 123, 124, 511 or 512.

CP 1/1 class 434 devices are active star couplers without timing regeneration with one or more wire-media ports. Their optical ports shall meet the specifications of CP 1/1 class 432 devices, while each of their electrical ports shall meet the relevant specifications of one of the following CP 1/1 device classes: 121, 122, 123, 124, 511 or 512.

5.2.2 Data-link layer

5.2.2.1 DLL service selection

5.2.2.1.1 General

Table 31 specifies the DLL service selection within IEC 61158-3-1 for this profile.

Table 31 – CP 1/1: DLL service selection

Clause	Header	Presence	Constraints
1	Scope	YES	—
2	Normative references	Partial	Used as needed
3	Terms, definitions, symbols, abbreviations and conventions	YES	—
4	Overview of Data-link Services	YES	—
5	DL(SAP)-address, queue and buffer management Data-link Service	—	See Table 32
6	Connection-mode Data-link Service	—	See Table 37
7	Connectionless-mode Data-link Service	—	See Table 52
8	Time and scheduling guidance Data-link Service	—	See Table 54
9	DL-Management service definition	NO	—

Table 32 – CP 1/1: DLL service selection of Clause 5

Clause	Header	Presence	Constraints
5.1	Facilities of the DL(SAP)-address, queue and buffer management Data-link Service	YES	—
5.2	Model of the DL(SAP)-address, queue and buffer management Data-link Service	YES	—
5.3	Sequence of primitives at one DL(SAP)	YES	—
5.4	DL(SAP)-address, queue and buffer management Services	—	See Table 33

Table 33 – CP 1/1: DLL service selection of 5.4

Clause	Header	Presence	Constraints
5.4.0	—	YES	—
5.4.1	Create	Partial	Only the attributes of the objects created by this service are included. See Table 34
5.4.2	Delete	NO	—
5.4.3	Bind	Partial	Only the attributes of the objects bound by this service are included. See Table 35
5.4.4	Unbind	NO	—
5.4.5	Put	YES	—
5.4.6	Get	—	See Table 36

Table 34 – CP 1/1: DLL service selection of 5.4.1

Clause	Header	Presence	Constraints
5.4.1.1	Function	NO	—
5.4.1.2	Types of parameters	—	—
5.4.1.2.0	—	Partial	IEC 61158-3-1, Table 2, is not included in this profile
5.4.1.2.1	Buffer-or-queue DLS-user-identifier	NO	—
5.4.1.2.2	Queuing policy	Partial	Only BUFFER-R and QUEUE are included
5.4.1.2.2.1	Maximum queue depth	YES	—
5.4.1.2.3	Maximum DLSDU size	YES	—
5.4.1.2.4	Status	NO	—
5.4.1.2.5	Buffer-or-queue DL-identifier	YES	—
5.4.1.3	Sequence of primitives	NO	—

Table 35 – CP 1/1: DLL service selection of 5.4.3

Clause	Header	Presence	Constraints
5.4.3.1	Function	NO	—
5.4.3.2	Types of parameters	—	—
5.4.3.2.0	—	YES	—
5.4.3.2.1	DL(SAP)-address DLS-user-identifier	NO	—
5.4.3.2.2	DL(SAP)-address	YES	—
5.4.3.2.3	DL(SAP)-role	Partial	Values of DL(SAP)-role are basic and group, other values are not included in this profile. IEC 61158-3-1, Table 4, is not included in this profile
5.4.3.2.3.1	Indicate-null-Unitdata-Exchange-transactions	NO	—
5.4.3.2.3.2	Remote-DLSAP-address	NO	—
5.4.3.2.4	Receiving buffer-or-queue bindings	YES	—
5.4.3.2.5	Sending buffer-or-queue bindings	YES	—
5.4.3.2.6	Default QoS as sender	—	—
5.4.3.2.6.0	—	Partial	Only the first paragraph immediately under IEC 61158-3-1, 5.4.3.2.6, is included
5.4.3.2.6.1	DLL priority	YES	—
5.4.3.2.6.2	DLL maximum confirm delay	Partial	All maximum confirm delays, except remotely-confirmed DL-UNITDATA, are included
5.4.3.2.6.3	DLPDU authentication	YES	—
5.4.3.2.6.4	DL-scheduling-policy	Partial	Only the value IMPLICIT is included
5.4.3.2.7	Status	NO	—
5.4.3.2.8	DL(SAP)-address DL-identifier	YES	—
5.4.3.3	Sequence of primitives	NO	—

Table 36 – CP 1/1: DLL service selection of 5.4.6

Clause	Header	Presence	Constraints
5.4.6.1	Function	YES	—
5.4.6.2	Types of parameters	—	—
5.4.6.2.0	—	Partial	IEC 61158-3-1, Table 8, except for 'DLS-user-data-timeliness' is included in this profile
5.4.6.2.1	Buffer-or-queue DL-identifier	YES	—
5.4.6.2.2	Status	YES	—
5.4.6.2.3	Reported-service-identification-class	YES	—
5.4.6.2.4	Reported-service-identification	YES	—
5.4.6.2.5	DLS-user-data	YES	—
5.4.6.2.6	DLS-user-data-timeliness	Partial	—
5.4.6.2.6.0	—	YES	—
5.4.6.2.6.1	Local-DLE-timeliness	YES	—
5.4.6.2.6.2	Sender-and remote-DLE-timeliness	YES	—
5.4.6.2.6.3	Time-of-production	NO	—
5.4.6.2.7	Sequence number identification	NO	—
5.4.6.3	Sequence of primitives	YES	—

Table 37 – CP 1/1: DLL service selection of Clause 6

Clause	Header	Presence	Constraints
6.1	Facilities of the connection-mode Data-link Service	YES	—
6.2	Model of the connection-mode Data-link Service	YES	—
6.3	Quality of connection-mode service	—	—
6.3.0	—	YES	—
6.3.1	Determination of QoS for connection-mode service	YES	—
6.3.2	Definition of QoS parameters	—	—
6.3.2.1	DLCEP class	Partial	All three classes are included, but data transfer from Subscriber to Publisher is not included
6.3.2.2	DLCEP data delivery features	Partial	See Table 38 for included parameter values
6.3.2.3	DLL priority	YES	—
6.3.2.4	DLL maximum confirm delay	YES	—
6.3.2.5	DLPDU authentication	Partial	See Table 38 for included parameter values
6.3.2.6	Residual activity	Partial	See Table 38 for included parameter values
6.3.2.7	DL-scheduling-policy	Partial	See Table 38 for included parameter values
6.3.2.8	Maximum DLSDU sizes	Partial	Single segment DLSDU size is the maximum size of a DLSDU that can be conveyed in one DLPDU of the specified priority. In other words, the DLL is not required to support segmentation of the DLSDU
6.3.2.9	DLCEP buffer-or-queue bindings	Partial	See Table 38 for included parameter values
6.3.2.10	DLCEP timeliness	Partial	All are included except IEC 61158-3-1, 6.3.2.10.1.4
6.4	Sequence of primitives	—	—
6.4.1	Concepts used to define the connection-mode DLL service	YES	—
6.4.2	Constraints on sequence of primitives	Partial	All of the referenced subclause, except DL-Reset and DL-Subscriber-Query services is included in this profile
6.4.2.1	Relation of primitives at the two DLC end-points	—	See Table 39
6.4.2.2	Sequence of primitives at one DLC end-point	Partial	IEC 61158-3-1, Figure 15, States 6 through 8 are not included in this profile because this profile does not include the DLC Reset service primitives
6.5	Connection establishment phase	—	See Table 40
6.6	Connection release phase	—	See Table 40
6.7	Data transfer phase	—	See Table 48

Table 38 – CP 1/1: DLL service selection of the summary of 6.3, DL-connection QoS

DLCEP Data Delivery feature	DLCEP Class	Buffer, Queue binding	Data Direction	DLPDU authentication	Max DLSDU size	DL-Scheduling	Residual Activity
CLASSICAL	PEER	QUEUE	Both directions	All three	Single segment DLSDU size	IMPLICIT	TRUE FALSE
DISORDERED	PEER	QUEUE	Both directions	All three	Single segment DLSDU size	IMPLICIT	TRUE FALSE
ORDERED	PUBLISHER SUBSCRIBER	BUFFER-R	Publisher to Subscriber only	SOURCE, ORDINARY	Single segment DLSDU size	EXPLICIT	FALSE
UNORDERED	PUBLISHER SUBSCRIBER	BUFFER-R	Publisher to Subscriber only	SOURCE, ORDINARY	Single segment DLSDU size	EXPLICIT	FALSE

Table 39 – CP 1/1: DLL service selection of Figures 9 to 14 of 6.4

Figure	Sub-part of figure	Presence	Reason
9	a), c), d), e), f), g1), g2), g3)	YES	—
	b)	NO	Profile does not merge connections
10	h), i), n)	YES	—
	j), k), l), m), o), p)	NO	Corresponding services are not included
11	c), d), e), f), g1)	YES	—
	a), b), g2), g3)	NO	DLCEP-address is assigned by the DLS-user
12	h)	NO	DLCEP-address is assigned by the DLS-user
	i), o)	YES	—
	j), k), l), m), n), p)	NO	Corresponding services are not included
13	a), b), c2), c3)	NO	DLCEP-address is assigned by the DLS-user
	c1), d), e), f)	YES	—
	g)	NO	Corresponding services are not included
14	h), i), j), k)	NO	Corresponding services are not included

Table 40 – CP 1/1: DLL service selection of 6.5

Clause	Header	Presence	Constraints
6.5.1	Function	Partial	Simultaneous DL-CONNECT request primitives at the two DLSAPs cannot be merged into one DLC by the concurrently requesting- and-responding DLS-users in this profile
6.5.2	Types of primitives and parameters	Partial	Replace IEC 61158-3-1, Table 13 and Table 14, by IEC 61784-1, Table 41 and Table 42, respectively
6.5.2.1	Local-view identifiers	—	—
6.5.2.1.1	DLCEP DLS-user-identifier	NO	The DL-CONNECTION-ESTABLISHED indication primitive uses the DLCEP DL-identifier parameter
6.5.2.1.2	DLCEP DL-identifier	YES	—
6.5.2.2	Addresses	Partial	This profile includes a profile of all possible forms of addresses. The use of addresses for this profile is specified in Table 43 through Table 45
6.5.2.3	Quality of Service parameter set	Partial	All parameters except Time-of-production are included in this profile. For this profile, the value of Residual activity is the same for both directions: from sender and from receiver. The DLPDU-authentication parameter is not included in indication and confirm primitives of this profile
6.5.2.4	DLS-user-data	Partial	If the called address is a DLCEP-address, then the DLS-provider does not issue a DL-Connect indication at the called address. Therefore, in that case, DLS-user-data is not permitted in the request primitive. This parameter is permitted in all other primitives
6.5.3	Sequence of primitives	Partial	IEC 61158-3-1, Figures 18, 21 and 22, are included in this profile. IEC 61158-3-1, Figures 19, 20 and 24, are not included in this profile, because the DLCEP-address is assigned by the DLS-user, there is no DL-Connect indication to the DLS-user. IEC 61158-3-1, Figures 23 and 24, are not included in this profile, because the connections are not merged

Table 41 – CP 1/1: DLL service selection: replacement for Table 13 of 6.5

DL-Connect Parameter name	Request		Indication	Response	Confirm
	input	output	output	input	output
DLCEP DL-identifier		M	M	M (=)	M ^a
Called address	M		M (=)		
Calling address	M		M (=)		
Responding address				M	M (=)
Calling DLCEP-address	U			U	
QoS parameter set					
DLCEP class	U		M (=)	U ^b	M (=)
DLCEP data delivery features					
from requester to responder(s)	U		M (=, ^c)	U (=, ^c)	M (=)
from responder(s) to requester	U		M (=, ^c)	U (=, ^c)	M (=)
DLL priority	U		M (=)	U (\leq)	M (=)
Maximum confirm delay					
on DL-Connect	U		M (=)	U	M (=)
on DL-Data	U		M (=)	U	M (=)
DLPDU-authentication	U			U (^d)	
Residual activity ^e	U			U (^f)	
DL-scheduling-policy	U			U	
Maximum DLSDU sizes					
from requester	U		M (\leq)	U (\leq)	M (=)
from responder	U		M (\leq)	U (\leq)	M (=)
Buffer-and-queue bindings					
as sender	U			U	
as receiver	U			U	
Sender timeliness					
DL-timeliness-class	CU		M (=)	CU	M (=)
Time window size (ΔT)	CU			CU	
Synchronizing DLCEP	CU			CU	
Receiver timeliness					
DL-timeliness-class	CU		M (=)	CU	M (=)
Time window size (ΔT)	CU			CU	
Synchronizing DLCEP	CU			CU	
DLS-user-data	U		M (=)	U	M (=)

NOTE The Time-of-production parameter is not specified, because it is not used.

^a The DLCEP DL-identifier on the confirm primitive shall equal the DL-identifier specified in the corresponding DL-CONNECT request primitive.

^b The DLCEP classes shall match, Peer with Peer, and Publisher with Subscriber.

^c The DLCEP data delivery feature UNORDERED may be upgraded to ORDERED, and DISORDERED may be upgraded to CLASSICAL.

^d DLCEP establishment shall negotiate DLPDU-authentication from ORDINARY to SOURCE to MAXIMAL.

^e For this profile, the value of Residual activity is the same for both directions: from sender and from receiver.

^f DLCEP establishment shall negotiate Residual-activity from FALSE to TRUE.

Table 42 – CP 1/1: DLL service selection of 6.5, replacement for Table 14

DL-Connection-Established	Indication
Parameter name	output
DLCEP DL –identifier	M ^(a)
^a The DLCEP DL-identifier shall equal the DL-identifier returned in the corresponding DL-CONNECT response primitive.	

Table 43 – CP 1/1: DLL service selection of 6.5 for use of addresses for peer DLC

DL-Connect	Request	Indication	Response	Confirm
Called address	Remote DLSAP-address	M (=)	—	—
Calling address	Local DLSAP-address	M (=)	—	—
Responding address	—	—	Local DLSAP-address	M (=)
Calling DLCEP-address	DLCEP-address assigned by DLS-user	—	DLCEP-address assigned by DLS-user	—
NOTE — means that the parameter is not allowed.				

Table 44 – CP 1/1: DLL service selection of 6.5 for use of addresses for multipeer DLC connect request at publisher

DL-Connect	Request	Confirm
Called address	UNKNOWN	—
Calling address	Local DLSAP-address	—
Responding address	—	UNKNOWN
Calling DLCEP-address	Publisher DLCEP-address	—
NOTE 1 — means that the parameter is not allowed.		
NOTE 2 No DLS-user data is allowed in the request primitive, because there is no indication at the subscriber.		

Table 45 – CP 1/1: DLL service selection of 6.5 for use of addresses for multipeer DLC connect request at subscriber

DL-Connect	Request	Confirm
Called address	Publisher DLCEP-address	—
Calling address	Local DLSAP-address	—
Responding address	—	Publisher DLSAP-address
Calling DLCEP-address	not used	—
NOTE — means that the parameter is not allowed.		

Table 46 – CP 1/1: DLL service selection of 6.6

Clause	Header	Presence	Constraints
6.6.1	Function	YES	—
6.6.2	Types of primitives and parameters	Partial	Replace IEC 61158-3-1, Table 15, by IEC 61784-1, Table 47
6.6.2.0	—	YES	—
6.6.2.1	DLCEP-identifier-type	NO	—
6.6.2.2	DLCEP DLS-user-identifier	NO	—
6.6.2.3	DLCEP DL-identifier	YES	—
6.6.2.4	Originator	YES	—
6.6.2.5	Reason	YES	When the originator parameter indicates a DLS-user-initiated release, then the DLS-user can assign not only the values listed in IEC 61158-3-1, 6.6.2.5, but also other values to the reason parameter. These other values are considered as “reason unspecified” by IEC , 6.6.2.5. The DLS-provider shall deliver the DLS-user provided reason in the indication primitive. The DLS-user of this profile has reserved 16 values for such “reason unspecified”
6.6.2.6	DLS-user-data	YES	—
6.6.3	Sequence of primitives when releasing an established DLC/DLCEP	YES	—
6.6.4	Sequence of primitives in a DLS-user rejection of a DLC / DLCEP establishment attempt	Partial	IEC 61158-3-1, Figures 35 and 38 to 41, are included in this profile. IEC 61158-3-1, Figures 36, 37, 42 and 43, are not included in this profile, because the DLCEP-address is assigned by DLS-user, and there is no DL-CONNECT indication to the DLS-user

Table 47 – CP 1/1: DLL service selection: replacement for Table 15 of 6.6

DL-Disconnect	Request	Indication
Parameter name	input	output
DLCEP DL-identifier	M	M
Originator		M
Reason	U	M (=)
DLS-user-data	U	M (=)

Table 48 – CP 1/1: DLL service selection of 6.7

Clause	Header	Presence	Constraints
6.7.1	Queue data transfer	—	—
6.7.1.1	Function	YES	—
6.7.1.2	Types of primitives and parameters	Partial	Replace IEC 61158-3-1, Table 16 by IEC 61784-1, Table 49
6.7.1.2.0	—	YES	—
6.7.1.2.1	DLCEP DL-identifier	YES	DLCEP DL-identifiers in request and indication primitives are local to the DLE at which the primitive is issued
6.7.1.2.2	DLCEP DLS-user-identifier	NO	—
6.7.1.2.3	Queue DLS-user-identifier	NO	A separate Queue DLS-user-identifier is not included, because the DLCEP address is sufficient to identify the queue, if any queue is bound to the DLCEP
6.7.1.2.4	DLS-user-data	YES	—
6.7.1.2.5	Sequence-number-identification	NO	—
6.7.1.2.6	Status	YES	—
6.7.1.3	Sequence of primitives	Partial	IEC 61158-3-1, Figures 45 and 46, are not included in this profile, because DLCEP data delivery or QoS are not included
6.7.2	Buffer data transfer	—	—
6.7.2.1	Function	YES	—
6.7.2.2	Types of primitives and parameters	Partial	Replace IEC 61158-3-1, Table 17 and Table 18, by IEC 61784-1, Table 50 and Table 51, respectively.
6.7.2.2.0	—	YES	—
6.7.2.2.1	DLCEP DLS-user-identifier	NO	A DLCEP DL-identifier is used in its stead
6.7.2.2.2	Buffer DLS-user-identifier	NO	—
6.7.2.2.3	DLSDU sequencing inference	YES	—
6.7.2.3	Sequence of primitives	Partial	IEC 61158-3-1, Figures 48, 50 and 51, are not included in this profile, because DLCEP data delivery or QoS are not included
6.7.3	Reset	NO	—
6.7.4	Subscriber query	NO	—

Table 49 – CP 1/1: DLL service selection of 6.7, replacement for Table 16

DL-Data	Request	Indication	Confirm
Parameter name	input	output	output
Request DLS-user-identifier	M		M (=)
DLCEP DL-identifier	M	M	
DLS-user-data	M	C (=)	
Status			M

Table 50 – CP 1/1: DLL service selection of 6.7, replacement for Table 17

DL-Buffer-Sent	Indication
Parameter name	output
DLCEP DL-identifier	M

Table 51 – CP 1/1: DLL service selection of 6.7, replacement for Table 18

DL-Buffer-Received	Indication
Parameter name	output
DLCEP DL-identifier	M
DLSDU sequencing inference	M

Table 52 – CP 1/1: DLL service selection of Clause 7

Clause	Header	Presence	Constraints
7.1	Facilities of the connectionless-mode Data-link Service	Partial	Paragraphs (b) to (e) are not included in this profile
7.2	Model of the connectionless-mode Data-link Service	—	—
7.2.0	—	YES	—
7.2.1	Model of DL-connectionless-mode unitdata transmission	YES	—
7.2.2	Model of DL-connectionless-mode unitdata exchange	NO	—
7.3	Quality of connectionless-mode service	—	—
7.3.0	—	YES	—
7.3.1	Determination of QoS for connectionless-mode service	YES	—
7.3.2	Definition of QoS parameters	—	—
7.3.2.1	DLL priority	YES	—
7.3.2.2	DLL maximum confirm delay	YES	—
7.3.2.3	Remote-DLE-confirmed	Partial	In this profile, the value of this parameter shall always be FALSE
7.4	Sequence of primitives	—	—
7.4.1	Constraints on sequence of primitives	Partial	All of the referenced subclause, except the rows for DL-UNITDATA-EXCHANGE and DL-LISTENER-QUERY and related notes in IEC 61158-3-1, Table 22, are included in this profile
7.4.2	Relation of primitives at the end-points of connectionless service	Partial	IEC 61158-3-1, Figure 65 (a), is included in this profile. IEC 61158-3-1, Figures 65 (b), (c) and (d), are not included in this profile
7.4.3	Sequence of primitives at one DLSAP	Partial	In IEC 61158-3-1, Figure 66, the transitions for DL-UNITDATA-EXCHANGE and DL-LISTENER-QUERY services are not included in this profile
7.5	Connectionless-mode functions	—	—
7.5.0	—	YES	—
7.5.1	Data transfer	—	—
7.5.1.1	Function	YES	—
7.5.1.2	Types of primitives and parameters	—	—
7.5.1.2.0	—	YES	—
7.5.1.2.1	Addresses	YES	—
7.5.1.2.2	Quality of Service	—	—
7.5.1.2.2.0	—	YES	—
7.5.1.2.2.1	DLL priority	YES	—
7.5.1.2.2.2	DLL maximum confirm delay	YES	—

Clause	Header	Presence	Constraints
7.5.1.2.2.3	Remote-DLE-confirmed	Partial	Value of this parameter shall always be FALSE
7.5.1.2.3	Queue DLS-user-identifier	NO	Queue DLS-user-identifier is not included, because the DLSAP address is sufficient to identify the queue, if any queue is bound to the DLSAP
7.5.1.2.4	DLS-user data	YES	—
7.5.1.2.5	Status	YES	—
7.5.1.3	Sequence of primitives	Partial	IEC 61158-3-1, Figure 68, is not included in this profile
7.5.2	Data exchange	NO	—
7.5.3	Listener query	NO	—

Table 53 – CP 1/1: DLL service selection of 7.5, replacement for Table 23

DL-Unitdata	Request	Indication	Confirm
Parameter name	input	output	output
Called address	M	M (=)	
Calling address	M	M (=)	
QoS parameter set			
DLL priority	U	M (=)	
DLL maximum confirm delay	U		
remote-DLE-confirmed	U		
DLS-user-data	M	C (=)	
Status			M

Table 54 – CP 1/1: DLL service selection of Clause 8

Clause	Header	Presence	Constraints
8.1	Facilities and classes of the time and scheduling guidance Data-link Service	Partial	Subclauses (b), (c), (e), (f), (g) and (h) are not included in this profile
8.2	Model of the time and scheduling guidance Data-link Service	YES	—
8.3	Quality of scheduling guidance service	YES	—
8.4	Sequence of primitives at one DLE	—	—
8.4.1	Constraints on sequence of primitives	Partial	All of the referenced subclause, except the rows for Schedule Sequence, Cancel Schedule and Subset Schedule services and related notes in IEC 61158-3-1, Table 26 and Figure 70, are not included
8.5	Scheduling guidance functions	—	—
8.5.0	—	YES	—
8.5.1	DL-time	YES	—
8.5.2	Compel service	—	—
8.5.2.1	Function	Partial	Subclauses (a), (b), (c), (d) and (f) are not included in this profile
8.5.2.2	Types of primitives and parameters	Partial	Replace IEC 61158-3-1, Table 28, by IEC 61784-1 Table 55
8.5.2.2.0	—	YES	—
8.5.2.2.1	Action class	Partial	Subclauses (c) and (d) are not included in this profile
8.5.2.2.1.0	—	YES	—
8.5.2.2.1.1	DLCEP DL-identifier	YES	—
8.5.2.2.1.2	Local-DLSAP-address DL-identifier	NO	—
8.5.2.2.1.3	Remote-DLSAP-address	NO	—
8.5.2.2.1.4	DLL-priority	NO	—
8.5.2.2.2	Schedule DL-identifier	N	—
8.5.2.2.3	Status	YES	—
8.5.2.3	Sequence of primitives	YES	—
8.5.3 – 8.5.5	—	NO	—

Table 55 – CP 1/1: DLL service selection of 8.5, replacement for Table 28

DL-Compel-Service Parameter name	Request	
	input	output
Action class	M	
DLCEP DL-identifier	M	
Status		M

5.2.2.2 DLL protocol selection

5.2.2.2.1 General

Table 56 specifies the selection of the Data-link services within IEC 61158-4-1 for this profile.

Table 56 – CP 1/1: DLL protocol selection

Clause	Header	Presence	Constraints
1	Scope	YES	—
2	Normative references	Partial	Used as needed
3	Terms, definitions, symbols and abbreviations	YES	—
4	Overview of DLL protocol	—	See Table 57
5	General structure and encoding of PhIDUs and DLPDUs, and related elements of procedure	YES	—
6	DLPDU-specific structure, encoding and elements of procedure	—	See 5.2.2.2.2
7	DLPDU-parameter structure and encoding	—	See 5.2.2.2.3
8	DLL service elements of procedure	—	See 5.2.2.2.4
9	DL-support sub-protocol	—	See 5.2.2.2.5
10	Other DLE elements of procedure	—	See 5.2.2.2.6
11	PICS proforma	NO	—
Annex A	Exemplary FCS implementations	Partial	Portions used as appropriate
Annex B	Formal protocol finite state machines	NO	—
Annex C	DLPDU and DL-addressing short-form summaries	Partial	As required by earlier clauses

Table 57 – CP 1/1: DLL protocol selection of Clause 4

Clause	Header	Presence	Constraints
4.1	Three-level model of the DLL	YES	—
4.2	Service provided by the DLL	Partial	The referenced subclause is the summary of service definitions. See 5.2.3.2 for details and the list of services that are not included
4.3	Structure and definition of DL-addresses	Partial	See Table 58 for the selection of subclauses
4.4	Service assumed from the Physical Layer	YES	—
4.5	Functions of the DLL	Partial	All types of functions specified in each subclause are included, but only to the extent required by the Data-link Services of this profile
4.6	Functional classes	YES	—
4.7	Local parameters, variables, counters, timers and queues	—	See Table 64 for the selection of subclauses

Table 58 – CP 1/1: DLL protocol selection of 4.3

Clause	Header	Presence	Constraints
4.3.0	—	YES	—
4.3.1	Form of DL-addresses	YES	—
4.3.2	Predefined Values and Ranges for DL-Address Components	—	—
4.3.2.0	—	YES	—
4.3.2.1	Link designators	Partial	Table 59 specifies the Link designators included in this profile
4.3.2.2	Node designators	YES	Table 60 specifies the use of Node designators included in this profile
4.3.2.3	Selectors	YES	The value 07 is reserved for the Application Layer Entity of this profile and shall be used as the default DLSAP-address for establishing connections
4.3.3	Predefined DL-Addresses	—	—
4.3.3.1	Predefined flat non-local DL-addresses	Partial	Table 61 specifies the Predefined flat non-local DL-addresses included in this profile
4.3.3.2	Predefined flat local DL-addresses	Partial	Table 62 specifies the Predefined flat local DL-addresses included in this profile
4.3.3.3	Predefined node-local DL-addresses	Partial	Table 63 specifies the Predefined node-local DL-addresses included in this profile
4.3.4	Representation of DL-Addresses as locally-administered 48-bit MAC-addresses	NO	—

Table 59 – CP 1/1: DLL protocol selection of 4.3.2.1 for use of link designators

Link	Usage
0000	Local link
0001	All links
1000 – ML	Individual link, where ML is the configured value of the highest link address. Each link shall be assigned only one address (primary), and a secondary link address shall not be assigned

Table 60 – CP 1/1: DLL protocol selection of 4.3.2.2 for use of node designators

Node	Usage
00	Local node, N =0 never appears on the bus
01 – 03	Flat link-local group DL-addresses, assignable in the link-local address range 0140 – 03FF
04	Flat link-local DLSAP-addresses, with link-local addresses of 0400 = LAS, 0404 = dominant bridge, 0440 – 04FF assignable to redundant device sets for node independence
05 – 0F	Flat link-local DLCEP-addresses, used by redundant device sets for node independence, with link-local addresses 0500 – 0FBF assignable to redundant device sets for node independence
10 – FF	Individual node, assigned based on device class and permanence and, for Bridge and Link master class devices, the preferred order of LAS role assumption (where a lower address takes precedence over a higher). Each node shall be assigned only a single node address; secondary node addresses shall not be used

**Table 61 – CP 1/1: DLL protocol selection of 4.3.3.1
for predefined flat non-local DL-addresses**

link N S	Assigned use for specified DL-address
0001 0000	The DL-support functions of “all” (see Note 1) DLEs on the extended link
0001 0001	The DL-support functions of “all” (see Note 1) LM DLEs on the extended link
0001 0002	The DL-support functions of “all” (see Note 1) Bridge DLEs on the extended link
0001 0003	The DL-bridge functions of “all” (see Note 1) Bridge DLEs on the extended link
0001 0009	The SMAEs of “all” (see Note 1) DLEs on the extended link
NOTE 1 DLEs which do not recognize LONG DL-addresses are necessarily excluded from these sets.	
NOTE 2 SMAE is the System Management Application Entity.	

**Table 62 – CP 1/1: DLL protocol selection of 4.3.3.2
for predefined flat link-local DL-addresses**

node selector	Assigned use for specified DL-address
01 00	The DL-support functions of all DLEs on the link
01 01	The DL-support functions of all LM DLEs on the link
01 02	The DL-support functions of all Bridge DLEs on the link
01 03	The DL-bridge functions of all Bridge DLEs on the link
01 09	The SMAEs of all DLEs on the link
04 00	The “DLSAP”-address for the DL-support functions of the DLE on the link which is serving as LAS
04 04	The “DLSAP”-address for the DL-bridge functions of the bridge DLE on the link which is dominant (closest to the root) in the bridge spanning tree

**Table 63 – CP 1/1: DLL protocol selection of 4.3.3.3
for predefined node-local DL-addresses**

selector	Assigned use for specified DL-address
00	The “DLSAP”-address for the DL-support functions of the node’s DLE
01	The “DLSAP”-address for the DL-bridge functions of the node’s DLE
02	The DLSAP-address for the same’s SMAE

Table 64 – CP 1/1: DLL protocol selection of 4.7

Clause	Header	Presence	Constraints
4.7.0	—	YES	—
4.7.1	Parameters, variables, counters, timers and queues to support the Basic class	—	—
4.7.1.0	—	YES	—
4.7.1.1	V(ST) slot-time	YES	—
4.7.1.2	V(PhLO) per-DLPDU-PhL-overhead	YES	—
4.7.1.3	V(MRD) maximum-response-delay	YES	—
4.7.1.4	V(IRRD) immediate-response-recovery-delay	YES	—
4.7.1.5	V(MRC) maximum-retry-count	Partial	Number of retries is always 0 for this profile
4.7.1.6	V(NRC) network-repeat-count	Partial	Number of repeats is always 0 for this profile
4.7.1.7	V(NDL) network-DLPDU-lifetime	Partial	Network-DLPDU-lifetime is always 0 for this profile
4.7.1.8	V(TN) this-node	YES	—
4.7.1.9	V(TL) this-link	YES	—
4.7.1.10	V(MEP) DL-MAC-address-embedding-prefix	NO	Variable is not used by the protocol
4.7.1.11	C(RD) remaining-duration counter	YES	—
4.7.1.12	V(MID) minimum-inter-DLPDU-delay	YES	—
4.7.1.13	T(IRRD) immediate-response-recovery-delay monitor	YES	—
4.7.1.14	V(RA) reply-address	YES	—
4.7.1.15	V(OTA) outstanding-transaction-array	NO	Not required because V(MRC)=0
4.7.1.16	V(LTI) last-transaction-index	NO	Not required because V(MRC)=0
4.7.1.17	Q(US) unscheduled-service queue	Partial	References to user requests as per items a.1), a.3) and a.4) only; items a.2), b) and c) do not apply to this profile
4.7.1.18	V(RID) random identifier	YES	—
4.7.1.19	C(NT) node-time counter	YES	—
4.7.1.20	V(LSTO) local-link-scheduling-time-offset	YES	—
4.7.1.21	V(DLTO) DL-time-offset	YES	—
4.7.1.22	V(TQ) time-quality	YES	—
4.7.1.23	V(MD) measured-delay	YES	—
4.7.1.24	V(LN) LAS-node	YES	—
4.7.1.25	V(TSC) time-synchronization-class	YES	—
4.7.1.26	T(TDP) time-distribution-period monitor	YES	—
4.7.1.27	V(TSL) time-source-link	YES	—
4.7.2	Parameters and timers to support a DLS-user's request	YES	—
4.7.3	Queues to support DL-address-based DL-scheduling	YES	—
4.7.4	Variables and timers to support a DLCEP	—	See Table 65
4.7.5	Variables and timers to support the Link master class	—	See Table 66
4.7.6	Variables and timers to support the Bridge class	YES	—

Table 65 – CP 1/1: DLL protocol selection of 4.7.4

Clause	Header	Presence	Constraints
4.7.4.0	—	YES	—
4.7.4.1	VC(ST) DLCEP state	YES	—
4.7.4.2	VC(NP) negotiated DLCEP parameters	YES	—
4.7.4.3	VC(N) next sequence number to assign to a DLSDU	YES	—
4.7.4.4	VC(R) maximum non-transmittable DLSDU sequence number	NO	Not required for DLCEP data delivery features of this profile
4.7.4.5	VC(A) maximum acknowledged DLSDU sequence number	YES	—
4.7.4.6	VC(M) maximum transmitted DLSDU sequence number	YES	—
4.7.4.7	VC(MS) maximum transmitted DLSDU segment number	NO	Max DLSDU size is restricted to one segment
4.7.4.8	VC,K (SS) segments to send	Partial	Number of segments is always one; only for Classical and Disordered Peer DLCs
4.7.4.9	TC,K(SS) sent-segments monitor	YES	—
4.7.4.9.1	TC(SS) simplified sent-segments monitor	YES	—
4.7.4.10	VC(L) last-reported DLSDU sequence number	YES	—
4.7.4.11	VC(H) highest-detected DLSDU sequence number	YES	—
4.7.4.12	VC(HS) highest-detected segment number of the highest-detected DLSDU sequence number	Partial	Max DLSDU size is restricted to one segment
4.7.4.13	VC,K(MRS) missing received segments	Partial	Number of segments is always one; only for Classical and Disordered Peer DLCs
4.7.4.14	VC,K(RRS) retransmission-request required segments	Partial	Number of segments is always one; only for Classical and Disordered Peer DLCs
4.7.4.15	TC,K(RRS) retransmission request monitor	NO	Not required for DLCEP data delivery features of this profile
4.7.4.16	TC(RAS) residual activity stimulus	YES	—
4.7.4.17	TC(RAM) residual activity monitor	YES	—
4.7.4.18	VC(TNA) DL-time of last network access	YES	—
4.7.4.19	VB(TW) DL-time of last buffer write	YES	—
4.7.4.20	VB(TP) DL-time of production	NO	Time-of-production is not included in this profile
4.7.4.21	VB(TS) Timeliness-status of buffer write	YES	—

Table 66 – CP 1/1: DLL protocol selection of 4.7.5

Clause	Header	Presence	Constraints
4.7.5.0	—	YES	—
4.7.5.1	V(DTA) delegation-address	YES	—
4.7.5.2	V(LL) local-link live-list	YES	—
4.7.5.3	V(TCL) token-circulation list	YES	—
4.7.5.4	V(ENRL) expected-non-response list	NO	Fractional Duty Cycle (FDC) DLEs are not included in this profile
4.7.5.5	V(MST) maximum-scheduled-traffic	NO	LAS does not construct the schedule for this profile
4.7.5.6	V(MSO) maximum-scheduling-overhead	YES	—
4.7.5.7	V(DMDT) default-minimum-token-delegation-time	YES	—
4.7.5.8	V(DTHT) default-token-holding-time	YES	—
4.7.5.9	V(LTHT) link-maintenance-token-holding-time	YES	—
4.7.5.10	V(MTHA) maximum-token-holding-time-array	YES	—
4.7.5.11	V(TTRT) target-token-rotation-time	YES	—
4.7.5.12	V(ATRT) actual-token-rotation-time	YES	—
4.7.5.13	V(RTHA) remaining-token-holding-time-array	YES	—
4.7.5.14	V(NTHN) next-token-holding-node	YES	—
4.7.5.15	V(FUN) first-unpolled-node	YES	—
4.7.5.16	V(NUN) number-of-consecutive-unpolled-nodes	YES	—
4.7.5.17	P(TRD) token-recovery-delay	YES	—
4.7.5.18	V(TDP) time-distribution-period	YES	—
4.7.5.19	V(MICD) maximum-inactivity-to-claim-LAS-delay	YES	—
4.7.5.20	V(LDDP) LAS-data-base-distribution-period	YES	—

5.2.2.2.2 IEC 61158-4-1, Clause 6

5.2.2.2.2.1 General

The subclauses “6.x.4.3 Additional actions required of a Bridge class DLE” of IEC 61158-4-1, for $x = 1$ to 23, apply to this profile only for forwarding the DLPDU. The bridge function of this profile does not include updating its routing tables based on the received DLPDU.

Table 67 specifies the selection of the other subclauses for this profile.

Table 67 – CP 1/1: DLL protocol selection of Clause 6

Clause	Header	Presence	Constraints
6.0	—	Partial	All of the referenced subclause, except IEC 61158-4-1, Table 10 , which is replaced by IEC 61784-1, Table 68, is included in this profile
6.1	Establish Connection (EC) DLPDU	YES	—
6.2	Disconnect Connection (DC) DLPDU	YES	—
6.3	Reset Connection (RC) DLPDU	NO	DLC Reset is not part of the services included in this profile
6.4	Compel Acknowledgement (CA) DLPDU	NO	Acknowledgement from the remote DLE is not required for the services included in this profile
6.5	Compel Data (CD) DLPDU	Partial	See 5.2.2.2.2.2
6.6	Exchange Data (ED) DLPDU	NO	—
6.7	Data (DT) DLPDU	Partial	See 5.2.2.2.2.10
6.8	Status Response (SR) DLPDU	Partial	See 5.2.2.2.2.23
6.9	Compel Time (CT) DLPDU	YES	—
6.10	Time Distribution (TD) DLPDU	YES	—
6.11	Round-Trip-Delay Query (RQ) DLPDU	Partial	See 5.2.2.2.2.26
6.12	Round-Trip-Delay Reply (RR) DLPDU	Partial	See 5.2.2.2.2.27
6.13	Probe Node DL-address (PN) DLPDU	YES	—
6.14	Probe Response (PR) DLPDU	YES	—
6.15	Pass Token (PT) DLPDU	Partial	See 5.2.2.2.2.28
6.16	Execute Sequence (ES) DLPDU	NO	Schedule is executed only by the LAS
6.17	Return Token (RT) DLPDU	YES	—
6.18	Request Interval (RI) DLPDU	YES	—
6.19	Claim LAS (CL) DLPDU	YES	—
6.20	Transfer LAS (TL) DLPDU	Partial	See 5.2.2.2.2.31
6.21	Wakeup (WK) DLPDU	NO	Fractional Duty Cycle (FDC) DLEs are not included in this profile
6.22	Idle (IDLE) DLPDU	YES	—
6.23	Spare DLPDUs	YES	—
6.24	Reserved (can't use) DLPDUs	YES	—

Table 68 – CP 1/1: DLL protocol selection, replacement for Table 10 of 6.0

DLPDU class	Frame control	DL-addresses			Parameters	User data
		Destination	Source	2nd source		
EC 1	1111 LF00	[HL.]N.S	[HL.]N.S	[HL.]N.S	EC-p	o-DLSDU
EC 2	1110 LF00		[HL.]N.S	[HL.]N.S	EC-p	o-DLSDU
DC 1	0111 LF00	[HL.]N.S	[HL.]N.S		DC-p	o-DLSDU
DC 2	0110 LF00		[HL.]N.S		DC-p	o-DLSDU
CD 1	1111 LFPP	[HL.]N.S	[HL.]N.S		—	—
CD 2	1011 LFPP	[HL.]N.S	—		—	—
DT 1	1101 LFPP	[HL.]N.S	[HL.]N.S		SD-p	o-DLSDU
DT 2	1001 LFPP	[HL.]N.S	—		SD-p	o-DLSDU
DT 3	0101 LFPP		[HL.]N.S		SD-p	o-DLSDU
DT 5	0101 0F00		[PDA]		SD-p	o-DLSDU
SR	0001 0F11	[PSA]	N		o-SR-p	—
CT	0001 0F00	—	—		—	—
TD	0001 0F01	—	N		TD-p	—
RQ	1100 0F00	N.0	N.0		RQ-p	—
RR	1101 0F00	N.0	N.0		RR-p	—
PN	0010 0110	N	—		PN-p	—
PR	0010 0111	—	—		—	SPDU
PT	0011 0FPP	N	—		DD-p	—
RT	0011 0100	—	[DTH]		—	—
RI	0010 0000	—	[DTH]		DD-p	—
CL	0000 0001	—	N		—	—
TL	0000 0110	N	—		—	SPDU
Idle	0001 0F10	—	—		—	o-DLSDU

LEGEND:

L indicates the length of the associated DL-addresses (0 = SHORT, 1 = LONG).

F indicates final use of a token, or that a sequence should be finished rather than restarted.

PP specifies the priority of the DLPDU and any passed token

shading indicates a logically non-existent field.

— indicates a logically existent field whose contents are required to be null.

[HL.]N.S is a four-octet LONG DL-address (HLNS) when L = 1
or a two-octet SHORT DL-address (NS) with HL=00 implied when L = 0.

N is a one-octet NODE DL-address.

N.0 is the two-octet SHORT DL-address form of a one-octet NODE DL-address.

[PDA] is the implied DL-address equal to the explicit destination DL-address of the immediately prior DLPDU on the link, which was a CD DLPDU.

[PSA] is the implied DL-address equal to the implied or explicit source DL-address of the immediately prior DLPDU on the link.

o- indicates optional field contents.

xx-p indicates xx-class DLPDU parameters.

DLSDU is a DL Service Data Unit.

SPDU is a Support Protocol Data Unit.

5.2.2.2.2 IEC 61158-4-1, 6.5

In IEC 61158-4-1, 6.5, the COMPEL DATA (CD) DLPDU is used by a DLE to request the transfer of user data from another DLE and the destination address of a CD can be either a DLCEP-address or a DLSAP-address. In this profile, CD is used only by the LAS or by a subscriber to request the transfer of user data from a publishing DLCEP.

Table 69 specifies the selection of the subordinate subclauses for this profile.

Table 69 – CP 1/1: DLL protocol selection of 6.5

Clause	Header	Presence	Constraints
6.5.0	—	YES	—
6.5.1	Structure of the CD DLPDUs	Partial	See 5.2.2.2.2.3
6.5.2	Content of the CD DLPDU	—	—
6.5.2.0	—	Partial	See 5.2.2.2.2.4
6.5.2.1	Content of the CD DLPDU when specifying a destination DLSAP-address	NO	—
6.5.2.2	Content of the CD DLPDU when specifying a destination DLCEP-address	Partial	See 5.2.2.2.2.5
6.5.3	Sending the CD DLPDU	Partial	See 5.2.2.2.2.6
6.5.4	Receiving the CD DLPDU	—	—
6.5.4.0	—	Partial	See 5.2.2.2.2.7
6.5.4.1	Actions required of all DLEs	Partial	See 5.2.2.2.2.8
6.5.4.2	Additional actions required of a Link-master class DLE	YES	—
6.5.4.3	Additional actions required of a Bridge class DLE	Partial	See 5.2.2.2.2.9
6.5.4.4	Additional actions required of the current LAS DLE	YES	—

5.2.2.2.2.3 IEC 61158-4-1, 6.5.1

IEC 61158-4-1, 6.5.1 and all its subclauses (i.e. all formats and all fields) are included in this profile, but with a null SD-parameter.

5.2.2.2.2.4 IEC 61158-4-1, 6.5.2.0

The destination address shall be a DLCEP-address. The source address, if present shall be the subscriber's DL-address.

5.2.2.2.2.5 IEC 61158-4-1, 6.5.2.2

NOTE 1 Only a publisher's DLCEP-address is permitted as a destination DLCEP-address.

When the first address is a DLCEP-address, as in IEC 61158-4-1, 6.5.2(b) and 6.5.2(c), then

- a) this DLPDU shall request state information from the addressed DLCEP, and shall request that DLS-user data be included in the reply DLPDU, and
- b) the second address, if present, shall be a subscriber DLCEPs calling-DLSAP-address of the same DLC as the destination publisher DLCEP-address; and
- c) the SD-parameters field should not be present; and
- d) the user data shall be null.

NOTE 2 IEC 61158-4-1, 6.5.2(c), formats 1l and 1s, are used for subscriber-to-publisher communications when the DLPDU-authentication attribute is SOURCE. IEC 61158-4-1, 6.5.2(c), formats 2l and 2s, are used for subscriber-to-publisher communications when the DLPDU-authentication attribute is ORDINARY.

5.2.2.2.2.6 IEC 61158-4-1, 6.5.3

NOTE Since the destination is not a DLSAP-address, there is no immediate retry.

A CD DLPDU may be selected for transmission on the link when

- a) the sending DLE holds a scheduler token or delegated token which is the dominant token on the local link, and
- b) the remaining allocated duration of token usage, $C(RD)$, permits completion of the transactions prior to expiration of the token, where the transaction consists of sending the CD DLPDU that requires an immediate reply, and awaiting a worst-case SR DLPDU or worst-case permitted DT reply DLPDU containing DLS-user data.

If the DLE holds a delegated token, and no additional use of that token after sending this DLPDU and awaiting its immediate reply is needed at that time, then the DLE may set the final-token-use subfield of the CD DLPDU to the value FINAL; else that subfield shall have the value NOT-FINAL.

Each explicit DL-address in the CD DLPDU shall be delocalized before transmission as specified in IEC 61158-4-1, 5.2.2.4.

After sending a CD DLPDU, the sending DLE shall monitor the local link for a reply as specified in IEC 61158-4-1, 5.2.7.1.

The permissible reply DLPDU is either,

- 1) a DT DLPDU without a destination DL-address, or
- 2) a SR DLPDU.

5.2.2.2.2.7 IEC 61158-4-1, 6.5.4.0

NOTE Only a publisher's DLCEP-address is permitted as a destination DLCEP-address; there is no immediate retry. A received CD with a peer DLCEP-address as the destination address is ignored by the receiving DLE.

Each DL-address in the DLPDU shall be delocalized upon reception as specified in IEC 61158-4-1, 5.2.2.4.

A received CD DLPDU shall be treated as follows by the receiving DLE:

5.2.2.2.2.8 IEC 61158-4-1, 6.5.4.1

NOTE Subclause (c) is included only for publisher DLCEPs. For this profile, a CD addressed to a peer DLCEP is ignored.

- a) not included;
- b) not included;
- c) If the destination DL-address specified by the DLPDU designates an active DLCEP-address of a DLC for which the receiving DLE
 - is a publisher, and the DLL priority of the DLCEP is not equal to the priority specified in the received DLPDU, then the receiving DLE shall initiate a reply within a period of maximum-response-delay slot-times, $V(MRD) \times V(ST)$ octet-durations, of receipt of the CD DLPDU. The reply DLPDU shall be a DT DLPDU in the format negotiated for the DLC for the selected direction of transmission, and shall contain SD-parameters appropriate to the sending DLCEP, but should not contain DLS-user-data.
 - is a peer, then the receiving DLE shall ignore the received DLPDU;
- d) If (c) does not apply, and the destination DL-address specified by the DLPDU designates an active DLCEP-address of a DLC for which the receiving DLE is a publisher, then
 - 1) not included;
 - 2) The receiving DLE shall initiate a reply within a period of maximum-response-delay slot-times, $V(MRD) \times V(ST)$ octet-durations, of receipt of the CD DLPDU. The reply DLPDU shall be a DT DLPDU in the format negotiated for the DLC for the selected direction of transmission, shall contain SD-parameters appropriate to the sending DLCEP, and shall contain DLS-user-data if any was available and waiting for transmission or retransmission from the DLCEP;

- 3) not included;
- e) If the destination DL-address specified by the DLPDU designates an active DLCEP-address of a DLC for which the receiving DLE is a subscriber, then
 - 1) not included;
 - 2) The receiving DLE shall record the destination DL-address from the received CD DLPDU in V(RA) for subsequent association with the expected immediate reply DT DLPDU, which should be the next DLPDU received;
 - 3) The receiving DLE shall monitor the local link for a reply and then act based on the result of that monitoring, all as specified in IEC 61158-4-1, 5.2.7.3.

5.2.2.2.2.9 IEC 61158-4-1, 6.5.4.3

- a) Since every bridge class DLE has Link master capability, any actions specified in IEC 61158-4-1, 6.5.4.2, also apply to a Bridge class DLE.
- b) Subclauses (A) – (E), (1) and (2) do not apply.
 - 1) If the destination DL-address specified in the DLPDU is one which the bridge should forward but which the bridge DLE itself would not otherwise receive, then the bridge shall form and send a SR DLPDU,
 - i) within a period of maximum-response-delay slot-times, $V(\text{MRD}) \times V(\text{ST})$ octet-durations, of receipt of the CD DLPDU,
 - ii) with status indicating whether or not the bridge was able to buffer the received DLPDU.
 - 2) If the destination DL-address specified in the DLPDU is one which the bridge should forward, and the bridge was able to receive and buffer the DLPDU without error, then the received DLPDU shall be forwarded with modification of the frame-control field in the forwarded DLPDU as appropriate. See IEC 61158-4-1, 5.1.3.
 - 3) Does not apply
- c) It is a protocol error for a bridge DLE which will forward the received CD DLPDU to not send a SR reply DLPDU when a reply is required.

At most one bridge DLE on the local link should be forwarding the received CD DLPDU.

5.2.2.2.2.10 IEC 61158-4-1, 6.7

A DATA (DT) DLPDU is used to transfer a limited amount of transparent user data from one DLS-user to one or more other DLS-users; to acknowledge the transfer of such data; and to assist in the synchronization of DLCEPs and of DLS-users.

It is also used by a DLE to send an SPDU to one or more other DLEs.

Table 70 specifies the selection of the subordinate subclauses for this profile.

Table 70 – CP 1/1: DLL protocol selection of 6.7

Clause	Header	Presence	Constraints
6.7.0	—	—	—
6.7.1	Structure of the DT DLPDU	Partial	Modified as in 5.2.2.2.2.11
6.7.2	Content of the DT DLPDU	—	—
6.7.2.0	—	Partial	Modified as in 5.2.2.2.2.12
6.7.2.1	Content of the DT DLPDU when specifying a destination DL(SAP)-address	Partial	Modified as in 5.2.2.2.2.13
6.7.2.2	Content of the DT DLPDU when specifying a destination or source DLCEP-address	Partial	Modified as in 5.2.2.2.2.14
6.7.3	Sending the DT DLPDU	—	—
6.7.3.0	—	Partial	Modified as in 5.2.2.2.2.15
6.7.3.1	Transmission when the reply token is dominant	Partial	Modified as in 5.2.2.2.2.16
6.7.3.2	Transmission when the delegated token is dominant	YES	—
6.7.3.3	Transmission when the scheduler token is dominant	YES	—
6.7.4	Receiving the DT DLPDU	—	—
6.7.4.0	—	Partial	Modified as in 5.2.2.2.2.17
6.7.4.1	Actions required of all DLEs	—	—
6.7.4.1.1	Actions required when the reply token was not dominant at start-of-reception	Partial	Modified as in 5.2.2.2.2.18
6.7.4.1.2	Actions required when the reply token was dominant at start-of-reception and the receiving DLE sent the CA, CD or ED DLPDU which created the reply token	Partial	Modified as in 5.2.2.2.2.19
6.7.4.1.3	Actions required when the reply token was dominant at start-of-reception and the receiving DLE did not send the CA, CD or ED DLPDU which created the reply token	Partial	Modified as in 5.2.2.2.2.20
6.7.4.2	Additional actions required of a Link-master class DLE	YES	—
6.7.4.3	Additional actions required of a Bridge class DLE	—	—
6.7.4.3.0	—	Partial	Modified as in 5.2.2.2.2.21
6.7.4.3.1	Actions required when the reply token was dominant at start-of-reception and the receiving bridge DLE forwarded, but did not originate, the CA, CD or ED DLPDU which created the reply token	Partial	Modified as in 5.2.2.2.2.22
6.7.4.4	Additional actions required of the current LAS DLE	YES	—

5.2.2.2.2.11 IEC 61158-4-1, 6.7.1

IEC 61158-4-1, 6.7.1 and all its subclauses, except format 4 of DT DLPDU, are included in this profile.

5.2.2.2.2.12 IEC 61158-4-1, 6.7.2.0

The frame control field shall be encoded as specified in IEC 61158-4-1, Table 18.

Either the DL-addresses shall be

- a) the first a group DL-address and the second a DLSAP-address, or
- b) all DLSAP-addresses, or
- c) all DLCEP-addresses, or
- d) not included.

5.2.2.2.2.13 IEC 61158-4-1, 6.7.2.1

When the first address is a group DL-address as in IEC 61158-4-1, 6.7.2(a), then

- a) If the DLPDU format is format 1L or 1s, then
 - 1) the DLPDU is being used to implement the unitdata transfer service,
 - 2) the DL(SAP)-role for the source DLSAP-address shall be BASIC,
 - 3) the SD-parameters field shall be null, and
 - 4) the user data shall be a single DLSDU whose size is limited to the maximum size for the priority specified in IEC 61158-4-1, 6.7.1.1(b), and shall not be null.
- b) No other DLPDU format may be used.

When the addresses are DLSAP-addresses as in IEC 61158-4-1, 6.7.2(b), then

- c) If the DLPDU format is format 1L or 1s, then
 - 1) this DLPDU is being used to implement the unitdata transfer service,
 - 2) the DL(SAP)-role for the destination DLSAP-address shall be BASIC,
 - 3) the DL(SAP)-role for the source DLSAP-address shall be BASIC,
 - 4) the SD-parameters field shall be null, and
 - 5) the user data shall be a single DLSDU whose size is limited to the maximum size for the priority specified in IEC 61158-4-1, 6.7.1.1(b), and shall not be null.
- d) not included
- e) No other DLPDU format may be used.

5.2.2.2.2.14 IEC 61158-4-1, 6.7.2.2

When the first address is a DLCEP-address, as in IEC 61158-4-1, 6.7.2(c), then

- a) this DLPDU can convey a single DLSDU
 - 1) from one peer DLCEP to its corresponding peer DLCEP, or
 - 2) from a publisher DLCEP to its corresponding subscriber DLCEPs,

and

- b) the second address, if present, shall be the peer DLCEP-address of the same DLC as the destination DLCEP-address;
- c) the SD-parameters field shall specify state information for the addressed DLCEP, and the contents of this field shall be as described in IEC 61158-4-1, 9.4.2; and

NOTE The size and structure of this field is dependent on the QoS attributes associated with the DLCEP addressed by the destination DL-address specified in this DLPDU, and is determined during DLCEP establishment.

- d) the user data shall specify those octets of a DLSDU consistent with the negotiated DLSDU size and the segmentation information specified in the accompanying SD-parameters, and may be null.

NOTE 1 Formats 1l, 2l, 1s and 2s are used for peer-to-peer communications; 1l is used when the DLPDU-authentication attribute is source or maximal, 1s is used when the DLPDU-authentication attribute is source, 2l and 2s are used when the DLPDU-authentication attribute is ordinary.

Formats 3l and 3s are used for publisher-to-subscriber communications when the DLPDU-authentication attribute is ordinary or source.

The specific format to be used (of formats 1l to 3s) is determined as part of DLCEP establishment.

NOTE 2 Format 5 can be used instead of formats 2s and 3s, respectively, only when the sending DLE holds a reply token and when the DLPDU-authentication attribute is ORDINARY.

5.2.2.2.2.15 IEC 61158-4-1, 6.7.3.0

A DT DLPDU may be selected for transmission on the link when the sending DLE

- a) has just received a reply token in a CD DLPDU, permitting a single transmission of a DT or SR DLPDU, or
- b) holds a scheduler token or delegated token which is the dominant token on the local link, and when the remaining allocated duration of token usage, C(RD), permits completion of the DT DLPDU's transmission prior to expiration of the token.

Each explicit DL-address in the DLPDU shall be delocalized IEC 61158-4-1, 5.2.2.4 before transmission.

5.2.2.2.2.16 IEC 61158-4-1, 6.7.3.1

NOTE 1 Only CD DLPDU with publisher's DLCEP-address as destination address is included.

- a) A DT DLPDU may be sent on the link when the sending DLE has received a CD DLPDU addressed to one of its active DLCEP-addresses for which it has a publisher DLCEP, and the sending DLE is replying as specified by IEC 61158-4-1, 6.5.4.1, by forming as an immediate reply a DT DLPDU which may include a DLSDU which was already buffered at that responding DLE at the time of the CD DLPDU's reception.

When an immediate reply to a CD DLPDU is required, as specified in (a), then the replying DLE shall send a reply DT DLPDU within a period of maximum-response-delay slot-times, $V(\text{MRD}) \times V(\text{ST})$ octet-durations, of receipt of the requesting CD DLPDU.

The final-token-use subfield of the reply DT DLPDU shall have the same value as that in the requesting CD DLPDU.

Each explicit DL-address in the reply DT DLPDU shall be delocalized IEC 61158-4-1, 5.2.2.4 before transmission.

It is a protocol error for the addressed DLE to not send a DT reply DLPDU when a reply is required.

At most one DLE on the local link should be sending a reply to the received CD DLPDU. That reply shall be a DT DLPDU.

5.2.2.2.2.17 IEC 61158-4-1, 6.7.4.0

Each DL-address in the DLPDU shall be delocalized IEC 61158-4-1, 5.2.2.4 upon reception. A received DT DLPDU shall be treated as follows by the receiving DLE.

5.2.2.2.2.18 IEC 61158-4-1, 6.7.4.1.1

NOTE 1 Subclause (b) is not included. In subclause (c), subscriber to publisher DT DLPDU is not included.

- a) If the received DT DLPDU has format 1L or 1s, and its destination DL-address designates a DL(SAP)-address of the receiving DLE, then the received DLPDU shall be forwarded to the DLE's upper-level functions IEC 61158-4-1, 10.3.1.3, for further processing.
- b) not included
- c) If the received DT DLPDU
 - 1) has format 1L, 1s, 2L or 2s, and its destination DL-address designates a DLCEP-address designating a peer DLCEP of the receiving DLE, or
 - 2) has format 3L or 3s, and its source DL-address designates a DLCEP-address designating a subscriber DLCEP of the receiving DLE, then the received DLPDU shall be forwarded to the DLE's upper-level functions IEC 61158-4-1, 10.2 for further processing.

- d) If the received DT DLPDU has format 1L or 1S, and its destination DL-address designates NODE.0 DL-address, V(TN).0, of the receiving DLEs DL-support functions, then the received DLPDU shall be forwarded to the DLEs upper-level functions IEC 61158-4-1, 12.3, for further processing.
- e) If none of (a) or (c) or (d) apply, then the DT DLPDU shall be reported to local DL-management as an unexpected response, and shall be discarded.

NOTE 2 It is possible that this report takes the form of incrementing a DL-management error counter.

5.2.2.2.2.19 IEC 61158-4-1, 6.7.4.1.2

- a) not included;
- b) not included;
- c) not included;
- d) If the received DT DLPDU has format 3L or 3S, and its source DL-address designates the publisher's DLCEP-address of a subscriber DLCEP of the receiving DLE, and this source DL-address is equal to the destination DL-address from the immediately-prior CD DLPDU, then
 - 1) the DLE shall consider the prior transmission to have been error-free, and
 - 2) the received DT DLPDU shall be forwarded to the DLEs upper-level functions IEC 61158-4-1, 10.2, for further processing;
- e) If the received DT DLPDU has format 5, and the explicit destination DL-address from the immediately-prior CD DLPDU was a DLCEP-address of a subscriber DLCEP of the receiving DLE, then
 - 1) the DLE shall consider the prior transmission to have been error-free, and
 - 2) the received DT DLPDU shall be forwarded to the DLEs upper-level functions IEC 61158-4-1, 10.2, for further processing, with its implied source DLCEP-address assumed to be the explicit destination DL-address from that immediately-prior CD DLPDU;
- f) If none of (d) to (e) apply, then the DT DLPDU shall be reported to local DL-management as an unexpected response, and shall be discarded.

NOTE It is possible that this report takes the form of incrementing a DL-management error counter.

5.2.2.2.2.20 IEC 61158-4-1, 6.7.4.1.3

NOTE Only CD DLPDU with publisher's DLCEP-address as destination address is included.

- a) If the received DT DLPDU has format 3L or 3S, and its source DL-address designates a DLCEP-address of a subscriber DLCEP of the receiving DLE, and this source DL-address is equal to the destination DL-address, V(RA), from the immediately-prior CD DLPDU, then
 - 1) the DLE shall consider the prior transmission to have been error-free, and
 - 2) the received DT DLPDU shall be forwarded to the DLEs upper-level functions IEC 61158-4-1, 10.2, for further processing.
- b) If the received DT DLPDU has format 5, and the explicit destination DL-address from the immediately-prior CD DLPDU was the publisher's DLCEP-address of a subscriber DLCEP of the receiving DLE, then
 - 1) the DLE shall consider the prior transmission to have been error-free, and
 - 2) the received DT DLPDU shall be forwarded to the DLEs upper-level functions IEC 61158-4-1, 10.2, for further processing, with its implied source DLCEP-address assumed to be the explicit destination DL-address from that immediately-prior CD DLPDU.

5.2.2.2.2.21 IEC 61158-4-1, 6.7.4.3.0

- a) Since every Bridge class DLE has Link master capability, any actions specified in IEC 61158-4-1, 6.7.4.2, also apply to a Bridge class DLE.

- b) If the first DL-address specified in the DLPDU is an explicit DL-address to which the bridge should forward the DLPDU and the bridge was able to buffer the DLPDU without error, then the DLPDU shall be forwarded with modification of the frame-control field in the forwarded DLPDU as appropriate IEC 61158-4-1, 5.1.3.
- c) not included
- d) Otherwise, if (b) does not apply, then the DLE shall not forward the DLPDU.

5.2.2.2.22 IEC 61158-4-1, 6.7.4.3.1

IEC 61158-4-1, 6.7.4.3.1 is not included in this profile, because it applies only if the destination address of the CD DLPDU was a DLSAP-address.

5.2.2.2.23 IEC 61158-4-1, 6.8

A STATUS RESPONSE (SR) DLPDU is sent only while holding a reply token; it is used

- a) to indicate the receipt of the immediately prior CD DLPDU by the bridge which would normally forward that DLPDU toward the addressed DLE, to indicate to the sending DLE that no error occurred, or that the indicated error occurred; and
- b) to reject an attempted transfer of the LAS role from the current LAS DLE to another link-master DLE.

Table 71 specifies the selection of the subordinate subclauses for this profile.

Table 71 – CP 1/1: DLL protocol selection of 6.8

Clause	Header	Presence	Constraints
6.8.0	—	YES	—
6.8.1	Structure of the SR DLPDU	YES	—
6.8.2	Content of the SR DLPDU	YES	—
6.8.3	Sending the SR DLPDU	YES	—
6.8.4	Receiving the SR DLPDU	—	—
6.8.4.0	—	YES	—
6.8.4.1	Actions required of all DLEs	Partial	Modified as in 5.2.2.2.24
6.8.4.2	Additional actions required of a Link-master class DLE	YES	—
6.8.4.3	Additional actions required of a Bridge class DLE	Partial	Modified as in 5.2.2.2.25
6.8.4.4	Additional actions required of the current LAS DLE	YES	—

5.2.2.2.24 IEC 61158-4-1, 6.8.4.1

NOTE Item (a) is not included, because this profile does not include CD DLPDUs with a DLSAP-address as the destination address.

- a) not included
- b) A received SR DLPDU, received as a reply to an immediately prior TL DLPDU which was originated by the receiving (LAS) DLE shall cause the receiving DLE
- 1) to consider the prior transmission to have been error-free, and
 - 2) as specified in IEC 61158-4-1, 6.20.3,
 - i) to re-assume the scheduler token,
 - ii) to inform local DL-management of the event, and
 - iii) to resume active operation as the LAS, and commence transmission on the link.

5.2.2.2.25 IEC 61158-4-1, 6.8.4.3

IEC 61158-4-1, 6.8.4.3 is not included in this profile, because this profile does not include CD DLPDUs with a DLSAP-address as the destination address.

5.2.2.2.26 IEC 61158-4-1, 6.11

A ROUND-TRIP-DELAY QUERY (RQ) DLPDU is sent from one DLE to the LAS DLE on the local link to initiate the measurement and computation of the round-trip delay intrinsic to their inter-communication. Its receipt results in the return of a complementary ROUND-TRIP-DELAY REPLY (RR) DLPDU completing the measurement.

Table 72 specifies the selection of the subordinate subclauses for this profile.

Table 72 – CP 1/1: DLL protocol selection of 6.11

Clause	Header	Presence	Constraints
6.11.1	Structure of the RQ DLPDU	YES	—
6.11.2	Content of the RQ DLPDU	Partial	Only local LAS, 0400 ₁₆ , as destination address is included
6.11.3	Sending the RQ DLPDU	Partial	Item (b) is not included, because this profile does not include the LAS as the source of an RQ DLPDU
6.11.4	Receiving the RQ DLPDU	—	—
6.11.4.1	Actions required of all DLEs	Partial	Only the LAS DLE is required to receive an RQ DLPDU for this profile
6.11.4.2	Additional actions required of a Link-master class or Bridge class DLE	YES	—
6.11.4.3	Additional actions required of a Bridge class DLE	YES	—
6.11.4.4	Additional actions required of the current LAS DLE	YES	—

5.2.2.2.27 IEC 61158-4-1, 6.12

A ROUND-TRIP-DELAY REPLY (RR) DLPDU is sent from LAS DLE to another on the local link to permit completion of the measurement and computation of the round-trip delay intrinsic to their inter-communication. It is only sent as an immediate reply to a received RQ DLPDU.

Table 73 specifies the selection of the subordinate subclauses for this profile.

Table 73 – CP 1/1: DLL protocol selection of 6.12

Clause	Header	Presence	Constraints
6.12.1	Structure of the RR DLPDU	YES	—
6.12.2	Content of the RR DLPDU	Partial	Only the source address of the local LAS, 0400 ₁₆ is included in this profile
6.12.3	Sending the RR DLPDU	Partial	Only the LAS DLE is required to send RR DLPDU for this profile
6.12.4	Receiving the RR DLPDU	YES	—

5.2.2.2.28 IEC 61158-4-1, 6.15

A PASS TOKEN (PT) DLPDU is used to pass a delegated token from the DLE functioning as a LAS to a DLE on the local link. By doing this repeatedly, the LAS DLE provides a delegated

token which “circulates” successively, usually in NODE DL-address order, to all active DLEs on the local link which are included in the link’s token-circulation list, V(TCL) IEC 61158-4-1, 4.7.5.3.

This DLPDU provides the receiving DLE with the right to initiate DL-transactions for a period of time specified in the delegating DLPDU.

Table 74 specifies the selection of the subordinate subclauses for this profile.

Table 74 – CP 1/1: DLL protocol selection of 6.15

Clause	Header	Presence	Constraints
6.15.1	Structure of the PT DLPDU	YES	—
6.15.2	Content of the PT DLPDU	Partial	For this profile, each DLEs NODE DL-address is in the live list, V(LL), and is also in the list of DLEs, V(TCL). Therefore, the value of DD-parameter is always non-zero
6.15.3	Sending the PT DLPDU	—	—
6.15.3.0	—	YES	—
6.15.3.1	Determination of the PT DLPDU fields and related “token-rotation” parameters	YES	—
6.15.3.2	Sending the PT DLPDU and monitoring the DLE to which the token is delegated	Partial	Modified as in 5.2.2.2.2.29
6.15.4	Receiving the PT DLPDU	—	—
6.15.4.0	—	YES	—
6.15.4.1	Actions required of all DLEs	Partial	The referenced subclause is included except that this profile does not include REPETITIVE sequences. Therefore, the token-use subfield of the received PT DLPDU need not be used by the receiving DLE
6.15.4.1.1	Selection of the next transaction to be executed	Partial	Modified as in 5.2.2.2.2.30
6.15.4.1.2	Additional considerations	YES	—
6.15.4.2	Additional actions required of a Link-master class or Bridge class DLE	YES	—
6.15.4.3	Additional actions required of a Bridge class DLE	YES	—
6.15.4.4	Additional actions required of the current LAS DLE	YES	—

5.2.2.2.2.29 IEC 61158-4-1, 6.15.3.2

NOTE Number of retry-count is zero for this profile.

d) If the monitoring period of immediate-response-recovery-delay slot-times, $V(IRR) \times V(ST)$ octet-durations, expires and a) does not apply, then the LAS DLE shall

- inform local DL-management of the event;

DLEs with node DL-addresses in the set $\{ F8_{16}..FF_{16} \}$ are expected to terminate operation by dropping out of the token circulation process. Thus, DL-management should not treat such occurrences as evidence of DLE or local-link malfunction.

- start the next transmission within token-recovery-delay slot-times, $P(TRD) \times V(ST)$ octet-durations, of the beginning of the current period of link non-activity.

5.2.2.2.2.30 IEC 61158-4-1, 6.15.4.1.1

All subclauses except as shown are included in this profile.

- (a.1) Compel of a DLSDU from a peer DLCEP is not included.
- (a.2) Is not included, because the DL-Unitdata exchange service is not included in this profile.
- (b) Is not included, because this profile does not include REPETITIVE sequences.
- (c) Is not included, because this profile does not include sequences.

5.2.2.2.2.31 IEC 61158-4-1, 6.20

A TRANSFER LAS (TL) DLPDU is used by the current LAS DLE to transfer the scheduler token and the role of LAS to another LM DLE on the local link. The TL DLPDU is sent only after having been requested by the addressed LM DLE, and may be rejected if the addressed DLE determines that its own copy of the local link's live-list is not current.

Table 75 specifies the selection of the subordinate subclauses for this profile.

Table 75 – CP 1/1: DLL protocol selection of 6.20

Clause	Header	Presence	Constraints
6.20.1	Structure of the TL DLPDU	YES	—
6.20.2	Content of the TL DLPDU	YES	—
6.20.3	Sending the TL DLPDU	Partial	Modified as in 5.2.2.2.2.32
6.20.4	Receiving the TL DLPDU	—	—
6.20.4.1	Actions required of all DLEs	YES	—
6.20.4.2	Additional actions required of a Link-master class or Bridge class DLE	Partial	Modified as in 5.2.2.2.2.33
6.20.4.3	Additional actions required of a Bridge class DLE	YES	—
6.20.4.4	Additional actions required of the current LAS DLE	YES	—

5.2.2.2.2.32 IEC 61158-4-1, 6.20.3

The LAS DLE shall reject a request to transfer the LAS role to a requesting DLE when

- a) the DLE has been instructed by the DLME to be the Primary Link master (that is, the preferred LAS) and

NOTE It is possible that some implementations use Network Management variable associated with the LAS DLE e.g. PrimaryLinkMaster to do so.

- b) the node-designator of the DLE requesting the transfer (that is, the node-designator of the DL-source address of the conveying DLPDU) has a higher numeric value than the node designator of this LM DLE (which is currently acting as LAS).

5.2.2.2.2.33 IEC 61158-4-1, 6.20.4.2

NOTE For this profile, schedule construction and execution abilities are not a consideration.

If the destination DL-address specified by the DLPDU designates the DLEs NODE DL-address, then

- a) If
- 1) the receiving DLE is not awaiting receipt of the TL DLPDU, or
 - 2) not included
 - 3) if the schedule construction and live-list information conveyed in the LAS-database-status SPDU within the received TL DLPDU indicates that the receiving DLE does not have a current copy of the live-list, then the receiving DLE shall reply with an SR DLPDU within a period of maximum-

response-delay slot-times, $V(\text{MRD}) \times V(\text{ST})$ octet-durations, as measured at the receiving DLE, with a status of “failure —LAS transfer rejected”.

- b) Otherwise, when (a) does not apply, then the receiving DLE shall assume the scheduler token, activate its LAS functions, and re-commence operation as the LAS.

5.2.2.2.3 IEC 61158-4-1, Clause 7

5.2.2.2.3.1 General

Table 76 specifies the selection of the subclauses for this profile.

Table 76 – CP 1/1: DLL protocol selection of Clause 7

Clause	Header	Presence	Constraints
7.0	—	YES	—
7.1	Structure and encoding of EC-Parameters	Partial	Modified as in 5.2.2.2.3.2
7.2	Structure and encoding of DC-Parameters	Partial	Modified as in 5.2.2.2.3.3
7.3	Structure and encoding of RC-Parameters	NO	This profile does not include sending or receiving a RC DLPDU
7.4	Structure and encoding of SD-Parameters	Partial	Modified as in 5.2.2.2.3.4
7.5	Structure and encoding of SR-parameters	YES	—
7.6	Structure and encoding of TD-parameters	YES	—
7.7	Structure and encoding of RQ-parameters	YES	—
7.8	Structure and encoding of RR-parameters	YES	—
7.9	Structure and encoding of PN-parameters	YES	—
7.10	Structure and encoding of DD-parameters	YES	—

5.2.2.2.3.2 IEC 61158-4-1, 7.1

NOTE Values of some of the fields are restricted.

This profile includes only a limited negotiation of the DLC. The values of some of the parameters is either fixed or limited by this profile to the following:

- a.1) as required
- a.2) as required
- a.3) path-diversity (Q) = 0 (ANY-PATH),
- a.4) protocol version number (V_{VV}) = 001.
- a.5) as required
- a.6) as required
- a.7) as required
- a.8) as required
- b) as required
- c.1) as required
- c.2) as required
- c.3) as required
- c.4) as required
- c.5) format subfield (FFF_S):
D for peer DLC;
A and G for multi-peer publisher DLC;

- c.6) 2-way data exchange subfield (E_S) = 0 (FALSE);
- c.7) as required
- c.8) as required
- c.9) time-stamp-format subfield (HHs) = 00 (format J i.e. null).
- c.10) as required
- d.1) as required
- d.2) as required
- d.3) as required
- d.4) as required
- d.5) format subfield (FFF_R):
D for peer DLC;
A and G for multi-peer publisher DLC;
- d.6) 2-way data exchange subfield (E_r) = 0 (FALSE);
- d.7) as required
- d.8) as required
- d.9) time-stamp-format subfield (HHr) = 00 (format J i.e. null).
- d.10) as required
- e.1) not used
- e.2) not used
- e.3) not used
- e.4) not used
- e.5) not used

5.2.2.2.3.3 IEC 61158-4-1, 7.2

- a) as required
- b) Not all reason codes listed in the referenced subclause are used. The required reason codes are specified in IEC 61158-4-1, 10.2, where the conditions leading to disconnect are specified. The reason codes in the range of 00 to 3F, which are not specified in the referenced subclause, are meant to be specified and used by the DLS-user. Within this range, reason codes 30 to 3F are reserved for use by the IEC 61158-4-1 DLS-user.

5.2.2.2.3.4 IEC 61158-4-1, 7.4

Table 77 specifies the selection of the subclauses for this profile.

Table 77 – CP 1/1: DLL protocol selection of 7.4

Clause	Header	Presence	Constraints
7.4.1	SD-Parameters in DLPDUs addressed to a DL(SAP)-address	NO	For connectionless data transfer, only the DT1 DLPDU is included for this profile. Therefore, only format P of the SD-parameters (the null format) is included for a DT1 DLPDU addressed to a DLSAP-address
7.4.2	SD-Parameters in DLPDUs addressed to a DLCEP	Partial	Modified as in 5.2.2.2.3.5
7.4.2.1	Parameters conveying DLCEP state and DLSDU timeliness	Partial	Only formats A, D, G are included
7.4.2.2	Parameters conveying DLSDU time-of-production	Partial	Only format J, the null format, is included

5.2.2.2.3.5 IEC 61158-4-1, 7.4.2 – SD-parameters in DLPDUs addressed to a DLCEP

The various SD-parameter formats, and their applicability to connection-oriented DT DLPDUs, for this profile are as follows:

- For a peer DLC: IEC 61158-4-1, Table 57, DLPDU frame formats 7 and 8, and DLPDU parameter formats D and J.
- For a multipeer DLC: IEC 61158-4-1, Table 57, DLPDU frame formats 3, 4, 9 and 11, and DLPDU parameter formats A, G and J.

The DLSDU source-time-stamp field, format J above, shall in all cases be null.

5.2.2.2.4 IEC 61158-4-1, Clause 8**5.2.2.2.4.1 General**

Table 78 specifies the selection of the subclauses for this profile.

Table 78 – CP 1/1: DLL protocol selection of Clause 8

Clause	Header	Presence	Constraints
8.0	—	YES	—
8.1	Operation of the DL(SAP)-address, buffer and queue management services	—	—
8.1.1	Receipt of a DL-CREATE request primitive	NO	—
8.1.2	Receipt of a DL-DELETE request primitive	NO	—
8.1.3	Receipt of a DL-BIND request primitive	NO	—
8.1.4	Receipt of a DL-UNBIND request primitive	NO	—
8.1.5	Receipt of a DL-PUT request primitive	Partial	All, except subclause 8.1.5 (c.5) are included, because the time-of-production is not included in this profile
8.1.6	Receipt of a DL-GET request primitive	Partial	All, except subclause 8.1.6 (a.4), 8.1.6(a.5) and 8.1.6(a.6) are included, because the time-of-production and sequence-number-identification and non-retentive buffer (BUFFER-NR) are not included in this profile
8.1.7	Computation of DL-timeliness	YES	—
8.2	Operation of the connection-mode services	Partial	Modified as in 5.2.2.2.4.2
8.3	Operation of the connectionless-mode services	Partial	This profile includes only Unitdata request, indication and confirm services, and without confirmation from the remote DLE. Modified as in 5.2.2.2.4.29
8.4	Operation of the scheduling guidance services	Partial	See 5.2.2.2.4.30

5.2.2.2.4.2 IEC 61158-4-1, 8.2

This profile only includes the procedures for Classical and Disordered Peer DLCEP bound to a queue and Ordered and Unordered Multi-peer DLCEP bound to a buffer, and without segmentation of DLSDUs. The scheduling for a Peer DLCEP is always implicit. The scheduling for the buffer transfer is always explicit. The DL-Connect response from the DLS-user does not try to merge two connections.

The following states and the transitions associated with these states in IEC 61158-4-1, Figure 13, are not included in this profile:

- 0: Aging DLCEP-address
- 6: Waiting for reset completion

See Table 79 for selection of subclauses of IEC 61158-4-1, 8.2.

NOTE Text is taken from IEC 61158-4-1, 8.2, and edited to satisfy the requirements of CP 1/1. Therefore, only the provision relevant for CP 1/1 are included.

Table 79 – CP 1/1: DLL protocol selection of 8.2

Clause	Header	Presence	Constraints
8.2.1	Operation of the DLCEP establishment and DLCEP release services	—	—
8.2.1.0	—	Partial	First paragraph is included in this profile. All other paragraphs are not included
8.2.1.1	DLC negotiation rules	Partial	(a), (c), (h), (i) and (j.2) apply only partially. The remainder of 8.2.1.1 is fully included. Replaced by 5.2.2.2.4.3
8.2.1.2	Receipt of a DL-CONNECT request primitive	Partial	(c), (e), (h), (j.2) are partially included. The remainder of 8.2.1.2 is fully included. Replaced by 5.2.2.2.4.4
8.2.1.3	Receipt of a DL-CONNECT response primitive	Partial	(d), (g), (h.2) and (i) are not included; (f) is partially included. Replaced by 5.2.2.2.4.5
8.2.1.4	Receipt of an EC DLPDU	—	—
8.2.1.4.0	—	YES	—
8.2.1.4.1	Receipt of an EC DLPDU with two addresses	YES	—
8.2.1.4.2	Receipt of an EC DLPDU with three addresses	Partial	Replaced by 5.2.2.2.4.6
8.2.1.5	Expiration of the timer $T_{U(MCD)}$	Partial	Replaced by 5.2.2.2.4.7
8.2.1.6	Receipt of a DL-DISCONNECT request primitive	Partial	Replaced by 5.2.2.2.4.8
8.2.1.7	Receipt of a DC DLPDU	Partial	Replaced by 5.2.2.2.4.9
8.2.1.8	DLE-initiated disconnection	Partial	Replaced by 5.2.2.2.4.10
8.2.2	Operation of the DLC data transfer services	—	See Table 80
8.2.3	Operation of the DLC subscriber query service	NO	DLC subscriber query service is not included in this profile

5.2.2.2.4.3 IEC 61158-4-1, 8.2.1.1

The DLS-user-visible aspects of the DLC negotiation rules are specified in IEC 61158-3-1. Additional negotiation rules which do not impact DLS-user visible aspects of the DLC are specified in IEC 61158-4-1, 7.1. In case of apparent conflict, the rules specified in 5.2.2.2.4.3 take precedence over those specified in IEC 61158-4-1, 7.1, which in turn take precedence over those specified in IEC 61158-3-1.

- a) If the publisher, or either peer, of a DLC specifies a DLPDU-authentication attribute of MAXIMAL, then

NOTE DLPDU-authentication of MAXIMAL is provided primarily for use in safety systems. For this reason it maximizes the amount of state information exchanged in each DLPDU sent on the DLC and prohibits two-way - user-data exchange in a single transaction, centralized schedule execution and other activities in which multiple DLEs need to have consistent state information.

- 1) each DLPDU sent from each DLCEP of the DLC shall contain the maximum permitted number of explicit addresses; and
- 2) the EC-parameters in each EC DLPDU shall be constrained as follows:
 - i) the address-size subfield (SS) shall specify LONG;
 - ii) the DLPDU-authentication subfield (XX) shall specify MAXIMAL;
 - iii) the residual-activity subfield (A) shall specify TRUE in the publisher-to-subscriber direction, or in all sending peer-to-peer directions, of data transfer;
NOTE Residual activity is not meaningful in the subscribers-to-publisher direction.
 - iv) both 2-way data exchange subfields (E) shall specify FALSE;
 - v) SD-parameter format B (subfield FFF), and time-stamp formats K and L (subfield HH), shall not be requested or used in either direction on the DLC.
- b) If (a) does not apply then
 - 1) If the publisher, or either peer, of a DLC specifies a DLPDU-authentication attribute of source, then the DLPDU-authentication subfield (XX) in the EC-parameters shall specify SOURCE, and each DLPDU sent from each DLCEP of the DLC shall contain the maximum permitted number of explicit addresses.
 - 2) If a subscriber of a DLC specifies a DLPDU-authentication attribute of MAXIMAL in a DL-CONNECT request primitive, then the DLPDU-authentication subfield (XX) in the resulting EC-parameters DLPDU shall specify MAXIMAL. If the requested DLC was already established, then
 - i) If that DLC was not established with DLPDU-authentication attribute of MAXIMAL then the publishing DLE shall reject the connection establishment request from that subscriber;
 - ii) Otherwise, when (A) does not apply, then the publishing DLE shall attempt to add that subscriber to the existing DLC.
 - 3) If a subscriber of a DLC specifies a DLPDU-authentication attribute of SOURCE in a DL-CONNECT request primitive, then the DLPDU-authentication subfield (XX) in the resulting EC-parameters DLPDU shall specify SOURCE. If the requested DLC was already established, then
 - i) If that DLC was established with a DLPDU-authentication attribute of ordinary then the publisher's DLE shall change the DLPDU-authentication to source and each DLPDU sent from each DLCEP of the DLC shall thereafter contain the maximum permitted number of explicit addresses,
 - ii) Otherwise, when (A) does not apply, then the publishing DLE shall attempt to add that subscriber to the existing DLC.
 - 4) Else if none of (i) to (iii) apply, then the DLPDU-authentication subfield (XX) in the EC-parameters shall specify ordinary, and each DLPDU sent from each DLCEP of the DLC shall contain the minimum permitted number of explicit addresses.
- c) The DLL path-diversity subfield (Q) of the EC-parameters shall specify ANY-PATH.
- d) The address-size subfield of the EC-parameters shall be determined as follows:
 - 1) If required by (a.2.i), or if any of the DL-addresses of the EC DLPDU have only a LONG representation, then the address-size subfield of the EC-parameters shall specify LONG.
 - 2) Else, when (1) does not apply, and either (b.i) applies or any member of the DLC is a fractional-duty-cycle (FDC) DLE, then the address-size subfield of the EC-parameters shall specify short.
 - 3) Otherwise, when (1) and (2) do not apply, the address-size subfield of the EC-parameters shall specify VERY-SHORT.

NOTE The address-size VERY-SHORT applies only to DT DLPDUs sent using a reply token IEC 61158-4-1, 6.7.1 formats 4 and 5; in all other cases the address-size SHORT is actually used.
- e) The DLCEP-data-delivery-features subfield (TT) of the EC-parameters shall specify, independently for each direction of the DLC, the provided data-delivery features, as

specified in IEC 61158-3-1, except that the value NONE shall be replaced by UNORDERED with a maximum window size (WWWW) of zero and maximum-DLSDU-size subfield (M...M) of zero in the corresponding direction, indicating a simplex DLC.

- f) The residual-activity subfield (A) of the EC-parameters shall specify true in a publisher-to-subscriber or sending peer-to-peer direction of data transfer when so required by (a.2.iii), or by DL-management, or by a publishing or peer DLS-user, and shall specify false otherwise. Negotiation of this subfield is from false to true.
- g) Window size negotiation occurs independently for each direction of the DLC. The actual maximum window size for a given direction of transmission shall be the smaller of the sender's maximum window size and the receiver's maximum window size in that direction, and the maximum-window-size subfield (WWWW) of the EC-parameters shall specify zero only when the maximum-DLSDU-size subfield (M...M) in the same direction is zero, indicating a simplex DLC.
- h) The SD-parameter-format subfield (FFF) of the EC-parameters shall specify the format for each direction of data transmission. Only the formats A, D and G are included in this profile. The formats for the transmission shall be selected by the following procedure:
 - 1) if DLCEP class is Peer then format D for both directions of data transmission; else if DLCEP class is Multi-peer then
 - i) if the data-delivery-feature is ORDERED or Timeliness is required then format G;
 - ii) else if the data-delivery-feature is UNORDERED then format A.
- i) The 2-way-data-exchange subfield (E) shall specify FALSE.
- j) Timeliness attributes of the DLCEP are communicated but not negotiated.
 - 1) The timeliness-included subfield (G) of the EC-parameters shall specify FALSE when the specified sender-timeliness is NONE, and shall specify TRUE otherwise.
 - 2) The time-stamp-format subfield (HH) of the EC-parameters shall specify format J (null).
- k) If one direction of data communication is not required for the DLC, because the DLS-user-specified data delivery features for that direction specified NONE, then in that direction
 - 1) The residual-activity subfield (A) shall be specified as FALSE;
 - 2) The Queue/Buffer (B) subfield shall be specified as QUEUE;
 - 3) The timeliness subfield (G) shall be specified as FALSE; and
 - 4) The time-stamp-format subfield (HH) shall be specified as format J.

5.2.2.2.4.4 IEC 61158-4-1, 8.2.1.2

When the DLE receives a DL-CONNECT request primitive from a DLS-user, the DLE shall perform the following series of actions, and if any error is detected during the process, then the DLCEP shall be disconnected as specified in IEC 61158-4-1, 8.2.1.8.

NOTE The procedures of subclauses (a), (c) to (h) are local to the DLE and the implementation of the local procedures does not have to conform to the description in this document. The DLE of this profile does not assign DLCEP-address; therefore the procedures of IEC 61158-4-1, 8.2.1.2(h) and (j.2), are partially included. This profile does not require support for a DL-Connect request for an existing publisher DLCEP, and therefore, the procedure of IEC 61158-4-1, 8.2.1.2(c), is partially included and the procedure of IEC 61158-4-1, 8.2.1.2(e.1), has been changed to reject such request.

- a) The DLE shall assign a new DLCEP-identifier to the DLCEP which may result from the request, and provide that DLCEP-identifier to the DLS-user as the single output parameter of the request.
- b) The DLE shall create and start a user-request timer $T_U(\text{MCD})$ with a duration based on the user-specified maximum confirm delay for DL-CONNECT primitive. If the specified value was other than UNLIMITED, then the duration of this timer should be $V_c(\text{NP}).\text{MCD_CRS}$; otherwise the duration should be 60s. DL-management may override these preferred durations.

NOTE The value of $V(\text{NRC})$ is zero for this profile. Therefore the timer values in the above subclause (b) have been expressed for $V(\text{NRC}) = 0$.

- c) The DLE shall validate the calling-DLSAP-address provided by the DLS-user; if invalid, the DLE shall reject the DL-CONNECT request with a DL-DISCONNECT indication.
- d) The DLE shall validate the self-consistency of the requested QoS parameter set, where all static and non-specified dynamic parameters assume the default values associated with the calling-DLSAP-address, and where the following automatic adjustments to that QoS occur:
 - 1) Where any parameter is in violation of a local DL-management-imposed limit, then that parameter shall be set equal to that limit, if permitted by the negotiation rules specified in IEC 61158-4-1, 8.2.1.1, or the DLE shall reject the DL-CONNECT request with a DL-DISCONNECT indication.
 - 2) If any maximum DLSDU size equals zero or the sending DLCEP data delivery features specify NONE, then the corresponding sending DLCEP data delivery features shall be set to UNORDERED.

NOTE This special case is not considered to be a violation of the negotiation rules of IEC 61158-4-1, 8.2.1.1.

- e) If the calling address identifier is a DLCEP-identifier for an existing DLCEP, then
 - 1) If the existing DLCEP is a publisher DLCEP, then the DLE shall reject the DL-CONNECT request with a DL-DISCONNECT indication.
 - 2) If the existing DLCEPs DLCEP-class is PEER or SUBSCRIBER, then the DLE shall reject the DL-CONNECT request with a DL-DISCONNECT indication.
- f) Otherwise, if (e) does not apply, then the DLE shall determine the maximum send and receive window sizes based on the respective buffer-and-queue bindings, as follows
 - 1) If the DLCEP-features are NONE, then the corresponding window size shall be zero (0).
 - 2) Otherwise, if (1) does not apply, then
 - i) If the binding was to a buffer, then the corresponding window size shall be one (1).
 - ii) If the binding was to a queue-K, then the corresponding window size shall be the smaller of K or 15.
 - iii) If the default binding was used, then the corresponding window size shall be at least one (1).
 - iv) In all cases, DL-management can further constrain this window size.
- g) If the optional calling-DLCEP-address was specified in the request primitive, then the DLE shall assign the calling-DLCEP-address specified in the request primitive to the DLCEP; if any conflicting assignment is detected, then the DLCEP shall be terminated as specified in IEC 61158-4-1, 8.2.1.8.
- h) Otherwise, if (g) does not apply, and if the called address is a DLCEP-address presumed to be for a publisher DLCEP, then the DLE shall not assign any DLCEP-address to this DLCEP.

NOTE In this profile IEC 61158-4-1, 8.2.1.2(h), applies only to DL-Connect request primitive at a SUBSCRIBER, because for all others, the calling-DLCEP-address is specified in the request.

- i) The DLC shall initialize the DLCEPs VC(NP), VC(N), VC(R), VC(A), VC(M), VC(MS), VC(H), VC(HS) and VC(L) variables as specified in IEC 61158-4-1, 6.7.4.
- j) The DLE shall encode an EC DLPDU as specified in IEC 61158-4-1, 6.1 and 7.1.
 - 1) If the called-DL-address parameter specifies a DL(SAP)-address or DLCEP-address, then the DLE shall form an EC DLPDU with three addresses, whose values shall be, respectively,
 - i) the called-DL(SAP)-address or DLCEP-address,
 - ii) the DLCEP-address assigned to the DLCEP, or calling-DLSAP-address if no such assignment was done as in (h),
 - iii) the calling-DLSAP-address.
 - 2) If the called-DL(SAP)-address parameter specifies UNKNOWN, then
 - i) not used

- ii) The DLCEP-class is PUBLISHER, and the DLE shall form an EC DLPDU with two addresses, whose values shall be the DLCEP-address assigned to the DLCEP, and the calling-DLSAP-address, respectively.
- iii) not used
- k) If the DLCEP class of the DLE is to be either PEER or SUBSCRIBER, then
 - 1) If an EC DLPDU was formed, then
 - i) The DLE shall set the reply-requested field in the EC-parameters in the DLPDU.
 - ii) The DLE shall queue the DLPDU at TIME-AVAILABLE priority as specified in IEC 61158-4-1, 8.4.5.
 - 2) The DLE shall activate recognition of the DLCEPs local DLCEP-address and change the DLCEP state, $V_C(ST)$, to WAITING-FOR-EC-DLPDU.
- l) If the sending DLCEP class of the DLE is to be PUBLISHER, then
 - 1) The DLE shall clear the reply-requested field in the EC-parameters in the DLPDU.
 - 2) If the source DLCEP-address is not that of an existing DLCEP, then the DLE shall assign a new value to the publisher-DLCEP-address reuse-discriminator subfield (NNN) of the EC-parameters IEC 61158-4-1, 7.1(a.2).
 - i) If the DLE is capable of recording the publisher-DLCEP-address reuse-discriminator between DLCEP incarnations, then it should maximize the interval between reuse of the same discriminator value;
 - ii) Otherwise, when (i) does not apply, the DLE shall choose the discriminator value randomly.
 - 3) The DLE shall queue the DLPDU at TIME-AVAILABLE priority as specified in IEC 61158-4-1, 8.4.5.
 - 4) The DLE shall issue the DL-Connect confirm for the DLCEP immediately after transmission of the EC DLPDU.
 - 5) The DLE shall cancel the user-request timer $TU(MCD)$.
 - 6) If (e) did not apply, then the DLE shall activate recognition of the DLCEPs local DLCEP-address and change the DLCEP state, $VC(ST)$, to data-transfer -ready.

5.2.2.2.4.5 IEC 61158-4-1, 8.2.1.3

When the DLE receives a DL-CONNECT response primitive from a DLS-user, the DLE shall perform the following series of actions; if any error is detected during the process, then the DLCEP shall be disconnected as specified in IEC 61158-4-1, 8.2.1.8.

NOTE The procedures of subclauses (a), (c) and (f) are local to the DLE and the implementation of the local procedures does not have to conform to the description in this document. The following procedures are either not included or partially included for the following reasons:

IEC 61158-4-1, 8.2.1.3(d): this profile does not include DLCEP merging,
 IEC 61158-4-1, 8.2.1.3(f): the DLE of this profile does not assign the DLCEP-address,
 IEC 61158-4-1, 8.2.1.3(g): the DLS-user at the subscriber does not use DL-Connect response,
 IEC 61158-4-1, 8.2.1.3 (h.2), (i): the DLS-user at the publisher does not use DL-Connect response,

- a) The DLE shall validate the DLCEP-identifier, and the responding DLSAP-address or DLCEP-identifier, provided by the DLS-user, and shall associate the provided DLS-user-identifier with the DLCEP.
- b) If the identified DLCEP is not in the WAITING-FOR-CONNECT-RESPONSE state, the DLCEP shall be disconnected.
- c) The DLE shall validate the self-consistency of the response QoS parameter set, where all static and non-specified parameters assume their default values associated with the responding-DLSAP-address, and where the automatic adjustments to that QoS specified in IEC 61158-4-1, 12.2.1.2(d), occur. The DLE shall then validate the consistency of the resulting QoS parameter set with the corresponding parameters from the received EC DLPDU, and the adherence to the rules of parameter negotiation specified in IEC 61158-4-1, 8.2.1.1.
- d) not used

- e) If the responding address identifier in the DL-Connect response was a DLSAP-address, then
- 1) that DLSAP-address shall be used as the local DLSAP-address, and
 - 2) the DLE shall determine the local maximum send and receive window sizes based on the respective buffer-and-queue bindings, possibly further restricted by DL-management, as specified in IEC 61158-4-1, 8.2.1.2.
- The DLE shall then determine the actual maximum send window size as the smaller of the local send window size and the received EC DLPDUs receive window size, and the actual maximum receive window size as the smaller of the local receive window size and the received EC DLPDUs send window size, as specified in IEC 61158-4-1, 8.2.1.1. The DLE also shall perform all other required negotiations, as specified in IEC 61158-4-1, 8.2.1.1.
- f) The DLE shall assign the calling-DLCEP-address specified in the response primitive to the DLCEP-address to the DLCEP; if any conflicting assignment is detected, then the DLCEP shall be disconnected as specified in IEC 61158-4-1, 8.2.1.8, with a reason of "disconnection—incorrect DLCEP pairing, permanent condition".
- g) not used
- h) The DLE shall
- 1) encode an EC DLPDU not requesting a reply, with three addresses as specified in IEC 61158-4-1, 6.1 and 7.1, where its addresses are, respectively,
 - i) the first of the two source DL-addresses from the received EC DLPDU which resulted in the DL-CONNECT indication and its consequent DL-CONNECT response,
 - ii) the DLCEP-address just assigned to the DLCEP, and
 - iii) the responding DLSAP-address, respectively; and
 - 2) not used, and
 - 3) schedule the DLPDU for transmission at TIME-AVAILABLE priority as specified in IEC 61158-4-1, 8.4.5.
- i) not used
- j) If the responding DLCEP class is PEER, then the DLE shall
- 1) stop the timer which was started in IEC 61158-4-1, 8.2.1.4.2(b.4.iv)
 - 2) start a timer as in IEC 61158-4-1, 8.2.1.2(b), with a duration equal to the value for the maximum confirm delay on DL-Connect as specified in the DL-Connect response primitive;
 - 3) activate recognition of the DLCEPs local DLCEP-address, and
 - 4) change the DLCEPs state, VC(ST), to waiting-for-connect-completion.

5.2.2.2.4.6 IEC 61158-4-1, 8.2.1.4.2

NOTE The following procedures are either not included or partially included for the following reasons:
 IEC 61158-4-1, 8.2.1.4.2(a), (c.1): group destination address is not included in this profile,
 IEC 61158-4-1, 8.2.1.4.2(c.3), (d.1): this profile does not include repeating the sending of the EC DLPDU,
 IEC 61158-4-1, 8.2.1.4.2(c), (d): in this profile, these subclauses apply only to a peer DLC,
 IEC 61158-4-1, 8.2.1.4.2(b.2), (b.3), (d.2), (e): this profile does not include connection merger.
 Several input events are not possible in this profile, e.g. the conditions of IEC 61158-4-1, 8.2.1.4.2(c.1). This profile does not include testing for such input conditions, and thus implementations may ignore such conditions.

The DLE shall perform the following series of actions, and if any error is detected during the process, then the DLC shall be disconnected as specified in IEC 61158-4-1, 8.2.1.8.

- a) not used
- b) If the first address of the received EC DLPDU is a DLSAP-address, then
- 1) The DLE shall validate the self-consistency of the received EC DLPDU, where all static and non-specified dynamic parameters assume the default values associated with that called-DLSAP-address, and where any parameter in violation of a local DL-management-imposed limit shall be set equal to that limit, if permitted by the negotiation rules of IEC 61158-4-1, 8.2.1.1, or the DLCEP shall be disconnected as

specified in IEC 61158-4-1, 8.2.1.8, with a reason of "connection rejection — QoS not available, permanent condition".

- 2) not used
- 3) not used
- 4) The DLE shall assign a new DLCEP identifier to the DLCEP, and shall apply the negotiation rules of IEC 61158-4-1, 8.2.1.2(d). If any violation of the negotiation rules occurs, then the DLE shall disconnect the proposed DLCEP as specified in IEC 61158-4-1, 8.2.1.8, with a reason of "connection rejection—QoS not available, permanent condition". If no violation is detected, then for the DLS-user associated with the DLSAP-address which was the first address of the received EC DLPDU, the DLE shall
 - i) create a DLCEP, initializing its $V_S(NP)$, $V_S(N)$, $V_S(R)$, $V_S(A)$, $V_S(M)$, $V_S(MS)$, $V_S(H)$, $V_S(HS)$ and $V_S(L)$ variables as specified in IEC 61158-4-1, 6.7.4;
 - ii) record the source DLCEP-address and source DLSAP-address from the received EC DLPDU as the DLCEPs remote DLCEP-address and remote DLSAP-address, respectively and when sender's DLCEP class is PUBLISHER, also record the publisher-DLCEP-address reuse-discriminator of the EC DLPDU as the DLCEPs local publisher-DLCEP-address reuse-discriminator;
 - iii) report a DL-CONNECT indication to the DLS-user;
 - iv) start a timer to monitor for the DLS-user's response to the DL-CONNECT indication, as specified in IEC 61158-4-1, 8.2.1.2(b); and
 - v) change the DLCEP state, $V_C(ST)$, to WAITING-FOR-CONNECT-RESPONSE.
- c) Else if the first address of the received EC DLPDU is a DLCEP-address for an existing DLCEP, and if the addressed DLCEP is in the WAITING-FOR-EC-DLPDU state, then the DLE shall validate the received DLC parameters, and if an error is detected, then
 - 1) not used
 - 2) the DLE shall disconnect the DLCEP as specified in IEC 61158-4-1, 8.2.1.8, with a reason of "connection rejection—QoS not available, permanent condition".

If no error is detected during the validation of the received EC DLPDU, then

 - 3) not used
 - i) If the receiving DLCEPs DLCEP-class is PEER, then the two source DL-addresses of the received EC DLPDU shall be noted as the remote-DLCEP-address and remote-DLSAP-address of the DLCEP;
 - ii) If the DLCEP-class of the receiving DLCEP is PEER, then
 - A) a DT DLPDU not containing DLS-user data,
 - B) with a destination address equal to the first source DL-address specified in the received EC DLPDU, and
 - C) when the DLCEPs attributes require the DLPDU to have a source address, with a source address equal to the DLCEPs local DLCEP-address
 - D) shall be encoded and shall be queued at the DLCEPs priority as specified in IEC 61158-4-1, 8.4.5, to notify the peer DLE of the successful receipt of the confirming EC DLPDU;
 - iii) not used
 - iv) The DLE shall issue a DL-CONNECT confirm primitive, conveying the negotiated DLCEP-attributes, to the requesting DLS-user;
 - v) The DLE shall cancel the user-request timer $T_U(MCD)$ and change the DLCEP state to DATA-TRANSFER-READY.
- d) not used, including
 - 1) not used
 - 2) not used

- e) Else if the first address of the received EC DLPDU is a DLCEP-address for an existing DLCEP, and the received EC DLPDU requests a reply, and if the addressed DLCEP is in the DATA-TRANSFER-READY state, then
- 1) If the existing DLCEP is a publisher DLCEP, then the DLE shall
 - i) set each QoS parameter, and the publisher-DLCEP-address reuse-discriminator, equal to the corresponding parameter of the specified DLCEP, if permitted by the negotiation rules of IEC 61158-4-1, 8.2.1.1; and
 - ii) if necessitated by the rule of IEC 61158-4-1, 8.2.1.1(d), then change the address size of the existing DLC from VERY-SHORT to SHORT or from SHORT to LONG.
 - 2) If no negotiation-rule violation is detected, then the DLE shall
 - i) encode an EC DLPDU not requesting a reply, with two addresses as specified in IEC 61158-4-1, 6.1 and 7.1, where its addresses are, respectively,
 - A) the DLCEP-address of the existing DLC, and
 - B) the DLSAP-address associated with this existing DLCEP-address, respectively; and
 - ii) schedule the EC DLPDU for transmission at TIME-AVAILABLE priority as specified in IEC 61158-4-1, 8.4.5.
 - 3) When (2) does not apply because a negotiation rule violation was detected, then the DLE shall reject the received DLC-establishment request and terminate processing of the received EC DLPDU, as follows:
 - i) The DLE shall encode a DC DLPDU as specified in IEC 61158-4-1, 6.2 and 7.2, with its reply-requested field set to FALSE, with a reason of “provider-originated disconnection—QoS not available, permanent condition”, and schedule the DC DLPDU for transmission at TIME-AVAILABLE priority as specified in IEC 61158-4-1, 8.4.5.
 - ii) The DC DLPDU shall have both destination and source addresses IEC 61158-4-1, 6.2.1 formats 1L and 1S, the destination address shall be identical to the first source DL-address of the received EC DLPDU, and the source address shall be identical to the destination DL-address of that received EC DLPDU.
- f) Otherwise, the DLE shall ignore the received EC DLPDU.

5.2.2.2.4.7 IEC 61158-4-1, 8.2.1.5

NOTE The following procedures are either not included or partially included for the following reasons:
 IEC 61158-4-1, 8.2.1.5(a.2), (c.2): this profile does not include repeating the sending of an EC DLPDU,
 IEC 61158-4-1, 8.2.1.5(e): this profile does not include DLC Reset.

If the timer $T_U(\text{MCD})$ expires, then if the DLCEP state, $V_C(\text{ST})$, is

- a) waiting-for-EC-DLPDU, then
 - 1) If this is the $(V(\text{NRC})+1)$ 'th consecutive expiration, then
 - i) the DLE shall terminate processing of the request, and
 - ii) if the user-specified maximum confirm delay on the DL-CONNECT request primitive specified a value other than UNLIMITED, then
 - A) The DLE shall initiate a DL-Disconnect indication reporting “connection rejection—DLSAP unreachable, transient condition, local origin”; and
 - B) If the called address was either a DLSAP-address or a DLCEP-address, and the DLCEPs DLCEP-class is PEER, then the DLE
 - I) shall encode a DC DLPDU requesting disconnect, with a reason of “reason unspecified”, to the same DL-address as that to which the previous EC DLPDU had been sent, and
 - II) shall be queued at TIME-AVAILABLE priority as specified in IEC 61158-4-1, 8.4.5.
- b) waiting-for-connect-response, then the DLE shall disconnect the DLCEP as specified in IEC 61158-4-1, 8.2.1.8, specifying a disconnect reason of “provider-originated

disconnection — timeout”.

c) waiting-for-connect-completion, then

- 1) If this is the $(V(NRC)+1)$ 'th consecutive expiration, then the DLE shall disconnect the DLCEP as specified in IEC 61158-4-1, 8.2.1.8, specifying a disconnect reason of “provider-originated disconnection — timeout”.

d) DATA-TRANSFER-READY, then the DLE shall act as specified in IEC 61158-4-1, 8.2.2.10.

5.2.2.2.4.8 IEC 61158-4-1, 8.2.1.6

NOTE The following procedures are either not included or partially included for the following reasons:
 IEC 61158-4-1, 8.2.1.6(a.1), (a.2): group destination address is not included in this profile, the destination address of value Unknown is used only by the publisher,
 IEC 61158-4-1, 8.2.1.6(b.2): this profile does not include DLC Reset.
 This profile does not include connection aging, and therefore it is permitted to reuse the DLCEP-address any time after sending DC DLPDU.

When the DLE receives at a DLCEP a DL-DISCONNECT request from a DLS-user, then the DLE

a) shall encode a DC DLPDU as specified in IEC 61158-4-1, 6.2 and 7.2, requesting disconnect and specifying the DLS-user-given reason, and shall schedule the DLPDU for transmission at TIME-AVAILABLE priority as specified in IEC 61158-4-1, 8.4.5, except when the DLCEP

- 1) not used
- 2) not used

3) is a SUBSCRIBER DLCEP;

If DC DLPDU is encoded, then

- i) If the DLCEP being disconnected is a PEER DLCEP, then the DC DLPDU shall have both destination and source addresses IEC 61158-4-1, 6.2.1 formats 1L and 1S, and the destination address shall be the remote DLCEP-address of the DLC, if known, or the called-DL(SAP)-address of the initiating EC DLPDU in all other cases. The reply-requested field shall be set to TRUE in the DC-parameters of the initiating DC DLPDU.
- ii) If the DLCEP being disconnected is a PUBLISHER DLCEP, then the DC DLPDU shall have only a source address IEC 61158-4-1, 6.2.1 formats 2L and 2S. The reply-requested field shall be set to FALSE in the DC-parameters of the initiating DC DLPDU.
- iii) The source address of the DC DLPDU shall be the local DLCEP-address, if one exists; or the responding or calling local DLSAP-address, if one exists, or the called-DLSAP-address of the initiating EC DLPDU in all other cases.

b) shall terminate the DLCEP, including

1) for each outstanding (that is, not-yet-confirmed) DL-DATA request:

- i) remove the request from the appropriate DLCEP user-request queue, $Q_A(UR)$, and references to the request from all DLE queues;
- ii) initiate a DL-DATA confirm with the associated request identifier reporting “failure—reset or disconnection”; and
- iii) delete the timer $T_U(MCD)$ associated with the request.

2) not used

3) delete all timers associated with the DLCEP.

5.2.2.2.4.9 IEC 61158-4-1, 8.2.1.7

NOTE The following procedures are either not included or partially included for the following reasons:
 IEC 61158-4-1, 8.2.1.7(b): This profile never checks for a reply, and therefore never returns a responding DC DLPDU.
 IEC 61158-4-1, 8.2.1.7(c.5): This profile does not include connection aging, and therefore it is permitted to reuse the DLCEP-address any time after sending DC DLPDU.

When the DLE receives a DC DLPDU, specifying that the DLCEP should be disconnected, then

- a) The DLE shall determine the version number of the DLL protocol in use, as specified in the received DC DLPDU, and shall interpret the other DC-parameters of the DLPDU accordingly;
- b) not used
- c) If the received DC DLPDU
 - 1) specifies only a source address IEC 61158-4-1, 6.2.1 formats 2L and 2s, and the source address is a DLCEP-address of a multi-peer DLC to which the DLE is a subscriber, or
 - 2) specifies both destination and source addresses IEC 61158-4-1, 6.2.1 formats 1L and 1S, and
 - i) the destination address is a DL(SAP)-address, and the DLE has a DLCEP, at a DLSAP to which that DL(SAP)-address is bound, whose remote DLCEP-address has the same value as the received source DL-address, or
 - ii) the destination address is a DLCEP-address, and the remote DLCEP-address of the identified DLCEP has the same value as the received source DL-address,
 - iii) the destination address is a DLCEP-address, and the called DLSAP-address of the identified DLCEP has the same value as the received source DL-address,

then if the DLCEP is known to the local DLS-user, then

- 3) The DLE shall report a DL-Disconnect indication to the local DLS-user specifying both the non-local origin and the reason for the DL-Disconnect indication as received in the DC DLPDU;
- 4) The DLE shall terminate the DLCEP as specified in IEC 61158-4-1, 8.2.1.6.(b).

5.2.2.2.4.10 IEC 61158-4-1, 8.2.1.8

NOTE The following procedures are either not included or partially included for the following reasons: This profile does not include connection aging, and therefore it is permitted to reuse the DLCEP-address any time after sending DC DLPDU.

When the DLE determines on its own that it is necessary to disconnect the DLCEP, then

- a) If the DLCEP is known to the local DLS-user, then the DLE shall report a DL-Disconnect indication to the local DLS-user, specifying both the reason for the DL-Disconnect indication and that its origin was local.

NOTE The DLCEP will not be known to the local DLS-user if the disconnection occurs while processing a received EC DLPDU whose receipt had just triggered the DL to create the DLCEP.

- b) If
 - 1) the DLCEPs DLCEP-class is PEER or PUBLISHER; and
 - 2) the called DL(SAP)-address of the EC DLPDU which activated the DLCEP was not a group DL-address,
 then
 - 3) The DLE shall encode a DC DLPDU as specified in IEC 61158-4-1, 6.2 and 7.2, and shall schedule the DLPDU for transmission at TIME-AVAILABLE priority as specified in IEC 61158-4-1, 8.4.5.
 - 4) If the DLCEP being disconnected is a PEER DLCEP, then the DC DLPDU shall have both destination and source addresses IEC 61158-4-1, 6.2.1 formats 1L and 1S, and the destination address shall be the remote DLCEP-address of the DLC, if known, or the called-DL(SAP)-address of the initiating EC DLPDU in all other cases. The reply-requested field shall be set to TRUE in the DC-parameters of the initiating DC DLPDU.
 - 5) If the DLCEP being disconnected is a PUBLISHER DLCEP, then the DC DLPDU shall have only a source address IEC 61158-4-1, 6.2.1 formats 2L and 2s. The reply-requested field shall be set to FALSE in the DC-parameters of the initiating DC DLPDU.

- 6) The source address of the DC DLPDU shall be the local DLCEP-address, if one exists; or the responding or calling local DLSAP-address, if one exists, or the called-DLSAP-address of the initiating EC DLPDU in all other cases.
- c) The DLE shall terminate the DLCEP as specified in IEC 61158-4-1, 8.2.1.6.(b).

Table 80 – CP 1/1: DLL protocol selection of 8.2.2

Clause	Header	Presence	Constraints
8.2.2.0	—	YES	—
8.2.2.1	Selection of the format of a CA, CD, DT and ED DLPDUs	Partial	Replaced by 5.2.2.2.4.11
8.2.2.2	Receipt of a DL-DATA request primitive	Partial	Replaced by 5.2.2.2.4.12
8.2.2.3	Transmission of a DT DLPDU from a DLCEP	—	—
8.2.2.3.0	—	YES	—
8.2.2.3.1	Formation of the user-data field and related SD-parameter subfields	Partial	Replaced by 5.2.2.2.4.13
8.2.2.3.2	Formation of the other SD-parameter subfields	Partial	Replaced by 5.2.2.2.4.14
8.2.2.3.3	Transmission completion	Partial	Replaced by 5.2.2.2.4.15
8.2.2.4	Transmission of a CA, CD or ED DLPDU from a DLCEP	—	—
8.2.2.4.1	Transmission of a CA DLPDU	NO	—
8.2.2.4.2	Transmission of a CD DLPDU	Partial	Replaced by 5.2.2.2.4.16
8.2.2.4.3	Transmission of an ED DLPDU	NO	—
8.2.2.5	Validation and processing of SD-parameters in a CA, CD, ED or DT DLPDU received at a DLCEP	—	—
8.2.2.5.0	—	Partial	Replaced by 5.2.2.2.4.17
8.2.2.5.1	Validation of the NDS, TNS, ASN and truncated-DL-time subfields of the received SD-parameters		Replaced by 5.2.2.2.4.18
8.2.2.5.2	Validation of the NDR, RSN, J and K subfields of the received SD-parameters		Replaced by 5.2.2.2.4.19
8.2.2.5.3	Processing of the T and truncated DL-time subfields of the received SD-parameters		Replaced by 5.2.2.2.4.20
8.2.2.6	Validation and processing of user-data received in a DT DLPDU	Partial	Replaced by 5.2.2.2.4.21
8.2.2.7	Delivery of an entire DLSDU which has been completely received at a DLCEP	—	—
8.2.2.7.0	—	YES	—
8.2.2.7.1	Delivery to a receive buffer	Yes	—
8.2.2.7.2	Delivery to a receive queue	Partial	Replaced by 5.2.2.2.4.22
8.2.2.7.3	OSI-default delivery	YES	—
8.2.2.8	Receipt of a DT DLPDU addressed to a DLCEP	Partial	Replaced by 5.2.2.2.4.23
8.2.2.9	Receipt of a CD DLPDU	NO	Not included, because this profile does not include CA, ED DLPDU and CD DLPDU for peer DLC. In this profile the CD DLPDU for multipeer does not include the SD-parameter
8.2.2.10	Starting, cancellation and expiration of the timer $T_U(\text{MCD})$ on a DL-DATA request	Partial	Replaced by 5.2.2.2.4.24
8.2.2.11	Starting, cancellation and expiration of the timer $T_{C,K}(\text{SS})$	—	—
8.2.2.11.0	—	Partial	Replaced by 5.2.2.2.4.25
8.2.2.11.1	Use of the simplified timer $T_C(\text{SS})$	Partial	Replaced by 5.2.2.2.4.26
8.2.2.12	Starting, cancellation and expiration of the timer $T_{C,K}(\text{RRS})$	NO	—

Clause	Header	Presence	Constraints
8.2.2.13	Starting, cancellation and expiration of the timer $T_C(\text{RAS})$	Partial	Replaced by 5.2.2.2.4.27
8.2.2.14	Starting, cancellation and expiration of the timer $T_C(\text{RAM})$	Partial	Replaced by 5.2.2.2.4.28
8.2.2.15	Receipt of a DL-RESET request primitive	NO	—
8.2.2.16	Receipt of a DL-RESET response primitive	NO	—
8.2.2.17	Receipt of an RC DLPDU	NO	—
8.2.2.18	Expiration of the timer $T_U(\text{MCD})$ on a DL-RESET request or indication	NO	—
8.2.2.19	DLE-initiated reset	NO	—

5.2.2.2.4.11 IEC 61158-4-1, 8.2.2.1

NOTE 1 CA and ED DLPDUs are not included in this profile

The address format of all CD and DT DLPDUs sent from a DLCEP shall be chosen as determined during the DLCEP-establishment process IEC 61158-4-1, 8.2.1.1 and as specified in IEC 61158-4-1, 6.5.3 and 6.7.3, respectively. The SD-parameter format of all such CD and DT DLPDUs formed by the DLE shall be the same as that negotiated for the sending DLCEP IEC 61158-4-1, 7.1(c.5), 7.1(d.5), 8.2.1.1.

All CD DLPDUs sent from an LAS DLE as part of its schedule execution activities, and not from a DLCEP of the LAS DLE, shall specify an explicit destination address of the length negotiated in IEC 61158-4-1, 8.2.1.1 and shall omit both source address and SD-parameters.

NOTE 2 An address format of very-short is always realized by use of short addresses in any associated CD DLPDU.

5.2.2.2.4.12 IEC 61158-4-1, 8.2.2.2

NOTE 1 The following procedures are either not included or partially included for the following reasons:

IEC 61158-4-1, 8.2.2.2(d.1): this profile does not include explicit scheduling for DL-Data requests,

IEC 61158-4-1, 8.2.2.2(d.2.ii): the data delivery features of IEC 61158-4-1, 8.2.2.2 are not included in this profile.

If the request is accepted, as indicated by a returned status of “success” for the DL-DATA request, then upon completion of the request, either successfully or after failure, the DLE shall issue a DL-DATA confirm with the same request identifier as specified by the DLS-user in the corresponding DL-DATA request primitive, conveying the status of the request to the DLS-user.

The DLCEP source specified in the DL-DATA request should be bound to either an explicit (user-controlled) queue or to an implicit (DLE-controlled) queue. If the queue is full, or if the specified DLSDU length, $P_U(L)$, is invalid, or if the DLCEP-state $V_C(\text{ST})$ is not DATA-TRANSFER-READY, then the DLE shall immediately return the corresponding DL-DATA confirm indicating the reason for failure.

Otherwise

- The DLE shall create and start a user-request timer $T_U(\text{MCD})$ with a duration based on the user-specified maximum confirm delay for DL-DATA primitives. If the specified value was other than UNLIMITED, then the duration of this timer shall be equal to that user-specified maximum confirm delay; otherwise the duration should be 60 s. DL-management may override these preferred durations.
- The DLE shall assign the next unassigned sequence number $N = VC(N)$ to the request and its associated DLSDU;

- c) The DLE shall initialize the variable $V_C(N(SS))$ based on the length, $PN(L)$, of the N th DLSDU, to indicate that all segments of the N th DLSDU, and no other segments of that DLSDU, need transmission;
- d) The DLE shall append the request to the DLCEP-address's user-request queue, $Q_A(UR)$, as follows:
- 1) not used
 - 2) i) if $N > V_C(A) + P_C(WS)$, and the sending DLCEP is a CLASSICAL or DISORDERED peer, then the request shall be placed in the third partition of $Q_A(UR)$;
 - 3) Else if (2) does not apply, then the third partition of $Q_A(UR)$ is empty, and so the request shall be placed in the second partition of $Q_A(UR)$, and the DLE shall append to the DLEs unscheduled-service queue, $Q(US)$, a reference to $Q_A(UR)$ of the same priority as the just-appended request.

NOTE 2 $Q(US)$ never needs to have more references to a $Q_A(UR)$ than the number of DLSDUs waiting for transmission or retransmission.

The DLE shall increment $V_C(N)$.

5.2.2.2.4.13 IEC 61158-4-1, 8.2.2.3.1

NOTE The following procedures are either not included or partially included for the reasons shown below:
 IEC 61158-4-1, 8.2.2.3.1(a), (b.i), (b.iii), (b.iv): the data delivery features of IEC 61158-4-1, 8.2.2.3.1 is not included in this profile,
 IEC 61158-4-1, 8.2.2.3.1(b.2), (b.3): the ASN, TNS subfields are not part of the SD-parameter format of this profile,
 IEC 61158-4-1, 8.2.2.3.1(c.3.iii), (d.2):the DL-time subfield is not part of the SD-parameter format of this profile.

The T, NDS, and the DLPDUs user-data field, shall be formed as follows:

- a) not used
- b) If the sending DLCEP is bound to a sending queue, and is
 - i) not used;
 - ii) a DISORDERED or CLASSICAL PEER DLCEP, and there is a K such that $V_C(A) < K \leq \min(V_C(A)+P_C(WS), V_C(N)-1)$ and $V_{C,K}(SS)$ is non-empty;
 - iii) not used;
 - iv) not used;

then the DLE shall form the remainder of the DLPDU as follows:

- 1) the NDS subfield, if present, shall convey the lowest-order five bits of the value K , as appropriate;
- 2) not used
- 3) not used
- 4) the user-data field shall consist of all octets of user-data;
- 5) the T subfield shall specify FALSE;
- 6) not used;

and the DLE shall remove member from $V_{C,K}(SS)$;

- c) If the sending DLCEP is bound to a sending buffer, then
 - 1) The DLE shall increment $V_C(N)$, if the buffer has been written since the last transmission from the buffer on this DLCEP;
 - 2) The DLE shall let K equal $V_C(N)-1$;
 - 3) If K is not equal to zero, then the DLE shall form the remainder of the DLPDU as specified in (b.1) to (b.4) and as follows:
 - i) If the DLSDU has no timeliness attribute, then the T subfield shall specify FALSE;

- ii) If the DLCEP has a sender's-DL-timeliness class other than NONE, then the DLE shall
 - A) compute the timeliness of the S'th segment of the K'th DLSDU as specified in IEC 61158-4-1 8.1.7,
 - B) perform a logical AND of that computed timeliness status with the timeliness-status associated with writing the buffer, $V_B(TS)$ IEC 61158-4-1 6.7.4.21, and
 - C) convey that result in the T subfield of the DLPDU;
 - iii) not used;
- and the DLE shall remove member from $V_{C,K}(SS)$;
- d) If there is no such K as in (b), or if K is equal to zero in (c), or if the DLE is required to send the DLPDU without user-data as in IEC 61158-4-1 6.5.4.1(c) or 6.5.4.1(d), then
 - 1) the T subfield of the SD-parameters shall be encoded as zero (0); NDS shall be encoded as the appropriate number of low-order bits of $V_C(M)$;
 - 2) not used; and
 - 3) the user-data field shall be null.

5.2.2.2.4.14 IEC 61158-4-1, 8.2.2.3.2

NOTE 1 The following procedures are either not included or partially included for the following reasons: IEC 61158-4-1, 8.2.2.3.2(b.1): the check of segment number is not included, the text has been edited so that it only applies to SD-parameter format included in this profile.

The J, K, NDR and RSN subfields of the SD-parameters shall be formed as follows:

- a) If the sending DLCEP is a PUBLISHER DLCEP, then the J, K, NDR and RSN subfields of the SD-parameters shall be encoded as zero (0);
- b) If the sending DLCEP is a PEER DLCEP, then
 - 1) If there is a smallest K such that $V_C(L) < K \leq V_C(M)$ and $V_{C,K}(RRS)$ is non-empty, then
 - i) the J subfield of the SD-parameters shall be encoded as one (1);
 - ii) the NDR subfield shall convey the lowest-order four bits of the value K;
 - iii) the RSN subfield shall be encoded as zero; and
 - iv) $V_{C,K}(RRS)$ shall be set to empty.
 - 2) Otherwise, if (1) does not apply, then
 - i) the J and RSN subfields shall be encoded as zero (0), and
 - ii) the NDR subfield shall convey the lowest-order four bits of $(V_C(L)+1)$.
 - 3) If the value of the NDR subfield equals the value of the corresponding lowest-order bits of $(V_C(L)+1)$, then the K subfield shall be encoded as one (1); otherwise the K subfield shall be encoded as zero (0).

NOTE 2 If Receive window size, $PC(WR) = 1$, then $NDR = V_C(L)+1$; $RSN = 0$; $K = 1$; if $V_{C,L+1}(RRS)$ is non-empty, then $J = 1$; else $J = 0$.

5.2.2.2.4.15 IEC 61158-4-1, 8.2.2.3.3

NOTE The following procedures are either not included or partially included for the following reasons: IEC 61158-4-1, 8.2.2.3.3(a): the variable $V_C(MS)$ is not included in this profile, IEC 61158-4-1, 8.2.2.3.3(b): edited, because only unordered publisher DLCEP bound to buffer is included in this profile, IEC 61158-4-1, 8.2.2.3.3(c): edited, because only ordered publisher DLCEP bound to buffer is included in this profile,

- a) If the just-transmitted DLPDU contained DLS-user data, then the DLE shall update $V_C(M)$ from the local variable K of IEC 61158-4-1 8.2.2.3.1 as follows:
 - If $K > V_C(M)$, then $V_C(M)$ shall be set equal to K.
- b) If the sending DLCEP
 - 1) is a publisher DLCEP whose sending DLCEP features are UNORDERED; and

- 2) the DT DLPDU has a non-null user data field;

then

- 3) the DLE shall issue a DL-BUFFER-SENT indication primitive specifying the DLS-user-identifier if known, or the DL-identifier otherwise, for the DLCEP.

- 4) not used.

c) If the sending DLCEP

- 1) is a publisher DLCEP whose sending DLCEP features are ORDERED; and

- 2) the DT DLPDU has a non-null user data field;

then

- 3) the DLE shall issue a DL-BUFFER-SENT indication primitive specifying the DLS-user-identifier if known, or the DL-identifier otherwise, for the DLCEP.

- 4) not used.

d) If this DLCEP has been specified as a synchronizing DLCEP during the establishment of one or more other local DLCEPs, and if a DL-BUFFER-SENT indication primitive was issued in (b.1) or (c.1), then the DLE shall record the DL-time of network access, $V_C(\text{TNA})$, for use in the timeliness computations of those referencing DLCEP(s).

5.2.2.2.4.16 IEC 61158-4-1, 8.2.2.4.2

NOTE The following procedures are either not included or partially included for the following reasons:
IEC 61158-4-1, 8.2.2.4.2(a.2): in this profile, the CD DLPDU is used only from subscriber to publisher and data transfer from subscriber to publisher is not included,
The CD DLPDU for this profile does not include SD-parameter field.

IEC 61158-4-1, 8.2.2.4.2 does not apply to the LAS DLE when it sends CD DLPDUs as part of its scheduled activity and not from a DLCEP of the LAS DLE; such DLPDUs are constrained as specified in IEC 61158-4-1, 6.5 and 8.2.2.

Upon receipt of a transmission opportunity to compel transmission from a remote DLCEP, when

a) the DLC is

- 1) simplex, with DLS-user-data transmission only from the remote DLCEP to the local DLCEP (and possibly other DLCEPs);

- 2) not used.

b) the local execution of a DL-Compel-Service request primitive compels transmission from a remote publisher DLCEP;

then the DLE shall form and send a CD DLPDU of the specified priority; with DL-address field and SD-parameter field formats as specified in IEC 61158-4-1 6.5, 7.4 and 8.2.2.2; with the remote (destination) and local (source) DLCEP-addresses of the DLC, as appropriate; and with null SD-parameter-field.

- 1) not used;

- 2) not used;

- 3) not used; and

- 4) not used.

5.2.2.2.4.17 IEC 61158-4-1, 8.2.2.5.0

NOTE The following procedures are either not included or partially included for the following reasons:
IEC 61158-4-1, 8.2.2.5(1.i): this profile does not include connection merging,
IEC 61158-4-1, 8.2.2.5(2): this profile does not include DLC Reset,
Only formats A, D and G are included in this profile.

If the DLCEP state, $V_C(\text{ST})$, is

- 1) waiting-for-connect-completion, then

- i) not used
 - ii) the DLE shall issue a DL-CONNECTION-ESTABLISHED indication primitive to the receiving DLS-user and cancel the associated user request timer $T_U(\text{MCD})$;
 - iii) The DLE shall change the DLCEP state, $V_C(\text{ST})$, to DATA TRANSFER READY; and shall apply the remainder of IEC 61158-4-1, 8.2.2.5.0.
- 2) not used
- 3) not WAITING-FOR-CONNECT-COMPLETION, and not DATA-TRANSFER-READY, then the received DLPDU shall be ignored by the upper-level DLC functions.

Otherwise, the DLE shall validate and process the SD-parameters of the received DLPDU according to the SD-parameter format, $P_C(\text{NP.FFFR})$, negotiated for this (receiving) direction of DLC transmission. This validation and processing shall be as specified in the remainder of IEC 61158-4-1, 8.2.2.5, with format-dependent considerations as follows, based on the SD-parameter format (A – G) and the truncated DL-time format (J—M). The format-dependent value of the sending modulus MOD_S shall also be used in the procedures of IEC 61158-4-1, 8.2.2.6.

format A) The sending and receiving SD-parameters of the DLPDU are implicit and thus always valid; the implied values of RSN, T, TNS, ASN and truncated DL-time are all zero; and any accompanying user-data is a complete DLSDU. IEC 61158-4-1, 8.2.2.5.2, does not apply.

format D) The sending and receiving SD-parameters of the DLPDU are explicit; the sending modulus MOD_S equals 25; the receiving modulus MOD_R equals 24; the implied values of TNS and ASN are zero; and any accompanying user-data is a complete DLSDU.

format G) The sending SD-parameters of the DLPDU are explicit; the receiving SD-parameters of the DLPDU are non-existent; the sending modulus MOD_S equals 2⁵; the implied value of NDR is $V_C(\text{M})+1$; the implied values of RSN, TNS and ASN are zero; and any accompanying user-data is a complete DLSDU.

5.2.2.2.4.18 IEC 61158-4-1, 8.2.2.5.1

NOTE 1 The following procedures are either not included or partially included, or different for the following reasons:

IEC 61158-4-1, 8.2.2.5.1(b.1), (b.2), (b.3) and (b.4), are included only for CLASSICAL or DISORDERED DLCEP, IEC 61158-4-1, 8.2.2.5.1 (a), (b.2.ii), (b.3), are partially included, because this profile does not include segmentation (TNS subfield is not included),

Item (b.1) is not identical to IEC 61158-4-1, 8.2.2.5.1 (b.1), because this profile does disconnect instead of reset,

Item (c) is added as a new subclause for ordered DLCEP bound to receiving buffer.

In the following, $P_C(\text{NP.WWWW}_R)$ is the negotiated receive window size and $P_C(\text{NP.TTR})$ is the negotiated receiving DLCEP data delivery features.

- a) If $P_C(\text{NP.TTR})$ specifies unordered, as is always the case with format A, then if the received DLPDU's user-data field is non-null, then the receiving DLE
 - i) shall increment $V_C(\text{H})$, and shall let K equal the new value of $V_C(\text{H})$,
 - ii) not used
 - iii) shall process the received user-data as specified in IEC 61158-4-1 8.2.2.6.
- b) Otherwise, when $P_C(\text{NP.TTR})$ specifies ORDERED, DISORDERED or CLASSICAL, then

If the receiving DLCEP is a subscriber DLCEP, and this is the first DT DLPDU received after the DLCEP state was changed to DATA-TRANSFER-READY, then the DLE shall set the variables $V_C(\text{L})$ and $V_C(\text{H})$ to the value of the $N_R(\text{NDS})$ subfield of the received DT DLPDU.

If $P_C(\text{NP.TTR})$ is CLASSICAL or DISORDERED DLCEP, then the DLE shall compute

$$\text{TEMP} = (N_R(\text{NDS}) + P_C(\text{NP.WWWW}_R) - V_C(\text{H}) - 1) \text{ modulo } \text{MOD}_S \text{ (Eq. 16)}$$

and shall apply subclauses (1) to (4).

1) If

$$TEMP > (V_C(L) + 2 \times P_C(NP.WWWW_R) - V_C(H) - 1) \text{ modulo } MOD_S$$

then the received DLSDU sequence number is invalid; the procedures of IEC 61158-4-1 8.2.2.6 do not apply; and the DLE shall disconnect the DLCEP as specified in IEC 61158-4-1 8.2.1.8, specifying a disconnect reason of “wrong DLPDU format or parameters, permanent condition”.

2) Else if (1) does not apply, then if

$$TEMP > (P_C(NP.WWWW_R) - 1),$$

then

i) The DLE shall set N equal to $TEMP - (P_C(NP.WWWW_R) - 1)$; and

ii) The received DLSDU sequence number is for a new DLSDU, not previously received or inferred; the DLE shall repeat the following step (A) N times.

A) The DLE shall increment $V_C(H)$. Let K equal the just-incremented value of $V_C(H)$. Then $V_{C,K}(MRS)$ shall be created and shall indicate that segment number zero (0) of the K 'th DLSDU is missing; and $V_{C,K}(RRS)$ shall be created and shall indicate that segment number zero (0) of the K 'th DLSDU is missing.

B) not used.

iii) not used

iv) For all values of N ,

A) If there is any accompanying user data in the received DLPDU, then the DLE shall modify both $V_{C,K}(MRS)$ and $V_{C,K}(RRS)$ to indicate that the segment whose zero-origin number is equal to the value of $N_R(ASN)$ field is not missing, and the procedures of IEC 61158-4-1 8.2.2.6 also shall be applied.

B) If there is any $V_{C,K}(RRS)$, as created in (b.2.ii.A), which is not empty and which therefore requires a retransmission request, then

i) the DLE shall check for a reference to the DLCEP on the DLEs unscheduled-service queue, $Q(US)$, and

ii) if no such reference is found then the DLE shall add a reference to the DLCEP onto the DLEs unscheduled-service queue, $Q(US)$, to ensure that another DLPDU requesting retransmission of the missing segment, is sent from the receiving DLCEP.

3) Else if (1) and (2) do not apply, and

$$TEMP < V_C(L) + P_C(NP.WWWW_R) - V_C(H) \text{ modulo } MOD_S$$

then the received DLSDU sequence number is for a previously delivered, and on peer DLCs previously acknowledged, DLSDU. If there is any accompanying user data in the received DLPDU, then the DLE shall check for a reference to the DLCEP on the DLEs unscheduled-service queue, $Q(US)$, and if not found then add a reference to the DLCEP to the DLEs unscheduled-service queue, $Q(US)$, to ensure that another DLPDU reacknowledging the just-referenced DLSDU is sent from the receiving DLCEP. The procedures of IEC 61158-4-1 8.2.2.6 do not apply.

4) Else if (1), (2) and (3) do not apply, then the received DLSDU sequence number is for a previously received or inferred, but not yet acknowledged, or delivered, or both, DLSDU.

Let $K = V_C(H) + TEMP + 1 - P_C(NP.WWWW_R)$.

If there is any accompanying user data in the received DLPDU, and $V_{C,K}(MRS)$ indicates that the user data has not previously been received, then the DLE shall modify both $V_{C,K}(MRS)$ and $V_{C,K}(RRS)$ to indicate that the segment whose zero-origin number is equal to the value of $N_R(ASN)$ field is not missing, and the procedures of IEC 61158-4-1 8.2.2.6 also shall be applied.

c) If $P_C(NP.TT_R)$ is ORDERED, then

- i) The DLE shall compute
 $TEMP1 = (N_R(NDS) - V_C(H)) \text{ modulo } MOD_S;$
 $V_C(H) = TEMP1 + V_C(H);$
- ii) If $TEMP1 = 0$, then the received DLSDU sequence number is for a previously delivered DLSDU. The receipt of the duplicate DLPDU shall be reported to the DLS-user with a DL-BUFFER-RECEIVED indication specifying that the reported DLSDU is a duplicate DLSDU;
- iii) If $TEMP1 > 0$, then the received DLSDU sequence number is for a new DLSDU, not previously received or inferred. If there is any accompanying user data in the received DLPDU, then the procedures of IEC 61158-4-1 8.2.2.6 shall be applied.

NOTE 2 If receive DLCEP is CLASSICAL or DISORDERED PEER DLCEP and window size = 1, then

$TEMP1 = (N_R(NDS) - V_C(H)) \text{ modulo } MOD_S;$
 If $(V_C(H) == V_C(L))$, then
 if $(TEMP1 > 1)$ then it is invalid;
 if $(TEMP1 == 1)$ then it is a new DLSDU;
 increment $V_C(H)$;
 set $K = V_C(H)$;
 procedures of IEC 61158-4-1 8.2.2.6 apply;
 if $(TEMP1 == 0)$ then it is a repeat of a prior DLSDU;
 If $(V_C(H) == V_C(L)+1)$, then
 if $(TEMP1 > 0)$ then it is invalid;
 if $(TEMP1 == 0)$ then it is a repeat of a prior DLSDU;

5.2.2.2.4.19 IEC 61158-4-1, 8.2.2.5.2

NOTE 1 The following procedures are either not included or partially included for the following reasons:
 IEC 61158-4-1, 8.2.2.5.2(a): not required,
 IEC 61158-4-, 8.2.2.5.2(c): the data delivery features are not included in this profile.

In the following, $P_C(NP.WWWW_R)$ is the negotiated receive window size and $P_C(NP.TT_R)$ is the negotiated receiving DLCEP data delivery features.

- a) not used
 b) If the DLCEP is a CLASSICAL or DISORDERED peer DLCEP, and the J and K subfields of the received SD-parameters are not both zero, then the DLE shall compute

$$TEMP = (N_R(NDR) - V_C(A)) \text{ modulo } MOD_R$$

$$N = TEMP + V_C(A)$$

The received DLPDU is acknowledging a previously-unacknowledged transmitted DLSDU ($K=1$), or requesting retransmission of a segment of a previously-transmitted DLSDU ($J=1$), or both.

If $K=1$, and the DLCEP is a CLASSICAL or DISORDERED peer DLCEP, and $V_C(A) < N \leq V_C(M) + 1$,

then the DLE shall

- i) set $V_C(A)$ equal to $N-1$;
 ii) issue, in the order originally requested, a DL-DATA confirm for each DL-DATA request which was acknowledged by the received NDR;
 iii) cancel the set of associated user request timers $\{ T_U(MCD) \}$ for the just-confirmed DL-DATA requests;

- iv) cancel any retransmission timers $T_{C,K}(SS)$ associated with the just-confirmed DL-DATA requests, or the simplified timer $T_C(SS)$ associated with the DLCEP, and in this latter case (using $T_C(SS)$), if $V_C(A) < V_C(M)$, which implies that there are unacknowledged DLSDUs, then $T_C(SS)$ shall be restarted;
- v) where possible and permitted, move DL-DATA requests from the third partition to the second partition of the corresponding user-request queue, $Q_A(UR)$, as specified in IEC 61158-4-1, 8.2.2.2(d);

and

if the $V_{C,K}(SS)$ associated with the just-confirmed DL-DATA requests were not empty, then the DLE may cancel such retransmission requests and set the corresponding $V_{C,K}(SS)$ to empty.

If $J=1$, and N is greater than $V_C(A)$, and

$$N \leq V_C(M)$$

then the DLE shall add the RSN 'th member to the set $V_{C,N}(SS)$; and if the set $V_{C,N}(SS)$ was previously empty, then the DLE shall

- 1) cancel any retransmission timers $T_{C,N}(SS)$ associated with the N 'th DLSDU, or $T_C(SS)$ associated with the DLCEP, and
- 2) add to the DLEs unscheduled-service queue, $Q(US)$, a reference to $Q_A(UR)$ of the receiving DLCEP, to ensure that the requested DLPDU is sent from the receiving DLCEP.

c) not used.

NOTE 2 $Q(US)$ never needs to have more references to a $Q_A(UR)$ than the number of DLSDUs waiting for transmission or retransmission.

NOTE 3 If send window size = 1, then $V_C(M)$ is $V_C(A)$ or $V_C(A) + 1$;

Valid values of NDR are $V_C(A) + 1$ or $V_C(A) + 2$.

5.2.2.2.4.20 IEC 61158-4-1, 8.2.2.5.3

NOTE The following procedures are either not included or partially included for the following reasons:
IEC 61158-4-1, 8.2.2.5.3(b.1.ii): this profile does not include DL-time in SD-parameter,
IEC 61158-4-1, 8.2.2.5.3(b.2): this profile does not include DLSDU with more than one segment.

If the DLCEPs receive binding is to a buffer, then

- a) If the receiving DLCEP has a sender's DL-timeliness class of NONE, then the timeliness-status, $V_B(TS)$ IEC 61158-4-1, 6.7.4.21, associated with writing the buffer shall be set to FALSE.
- b) Otherwise, when (a) does not apply, then
 - 1)
 - i) The buffer's associated timeliness-status, $V_B(TS)$, specified in IEC 61158-4-1, 6.7.4.21, shall be set equal to the T subfield of the received DLPDU;
 - ii) not used
 - iii) the DL-time of reception of the DLPDU shall be used as the time of writing the buffer, $V_B(TW)$, specified in IEC 61158-4-1, 6.7.4.19.
 - 2) not used.

5.2.2.2.4.21 IEC 61158-4-1, 8.2.2.6

NOTE The following procedures are either not included or partially included for the following reasons:
IEC 61158-4-1, 8.2.2.6(a), (b), (c) and other text are excluded – this profile does not include DLSDUs with more than one segment, so re-assembly is never required.

If a received DT DLPDU has a non-null user data field following its SD-parameters field, then receiving DLE shall check whether the length of the received user-data is less than or equal to the permitted maximum DLSDU size, $P_C(NP.M...M_R)$, negotiated for this (receiving)

direction of DLC transmission. If this requirement is violated, then the DLE shall disconnect the DLCEP as specified in IEC 61158-4-1, 8.2.1.8, with a reason of “provider-originated disconnection–wrong DLSDU size, permanent condition”.

- a) not used
- b) not used
- c) not used
- d) The receiving DLE shall attempt to deliver the DLSDU as specified in IEC 61158-4-1, 8.2.2.7.

5.2.2.2.4.22 IEC 61158-4-1, 8.2.2.7.2

NOTE 1 The following procedures are either not included or partially included for the following reasons:
IEC 61158-4-1, 8.2.2.7.2(b): the timer TC,K(RRS) is not included in this profile,
IEC 61158-4-1, 8.2.2.7.2(c): the UNORDERED or ORDERED DLC bound to a queue is not included in this profile.

The DLE shall attempt to append the complete DLSDU, together with identification of the receiving DLCEP, to the receiving queue.

If unsuccessful, the DLE shall inform local DL-management of this queue-full situation.

NOTE 2 It is possible that this DL-management notification takes the form of incrementing a counter of discarded DLSDUs.

If successful,

- a) The DLE shall report a DL-DATA indication to the DLS-user;
- b) Not used
- c) Not used
- d) If the DLC is a DISORDERED DLC, and if K equals ($V_C(L) + 1$), then
 - 1) The DLE shall set $V_C(L)$ equal to K .
 - 2) If K is less than $V_C(H)$, then the DLE shall increment K . If the set variable $V_{C,K}(MRS)$ is empty, then the DLE shall set $V_C(L)$ equal to K and shall repeat this step.
 - 3) If the DLC is a PEER DLC, then if the DLEs DL-address unscheduled-service queue, Q(US), does not already contain a reference to the DLCEP, then the DLE shall append a reference to the DLCEP to that Q(US) to ensure that an acknowledgement of DLSDU receipt is sent from the receiving DLCEP.
- e) If the DLC is a CLASSICAL DLC, then
 - 1) The DLE shall set $V_C(L)$ equal to K .
 - 2) If K is less than $V_C(H)$, then the DLE shall increment K . If the set variable $V_{C,K}(MRS)$ is empty, then the DLE shall repeat the entire data delivery procedure IEC 61158-4-1, 8.2.2.7.2 (a) and (e), using the new value of K .
 - 3) If the DLC is a PEER DLC, then the DLE shall do as specified in IEC 61158-4-1, 8.2.2.7.2(d.3).

NOTE 3 If receive window size = 1, then K is always equal to $V_C(L) + 1$ and procedures for CLASSICAL and DISORDERED DLC are identical.

5.2.2.2.4.23 IEC 61158-4-1, 8.2.2.8

NOTE The following procedures are either not included or partially included for the following reasons:
IEC 61158-4-1, 8.2.2.8(a): this profile does not include DLC reset,
IEC 61158-4-1, 8.2.2.8(b3): this profile does not include Data transfer from Subscriber to Publisher.
IEC 61158-4-1, 8.2.2.8(c): this profile does not include residual activity for multipeer DLC.

When the DLE receives a DT DLPDU addressed to a DLCEP of the DLE, the DLE shall perform the following series of actions.

- a) not used

- b) The DLE shall validate that
- 1) the priority of the received DT is as expected;
 - 2) in a received DT DLPDU addressed to all subscribers of a PUBLISHER DLCEP, the length of the publisher's DL-address is greater than or equal to that expected;
 - 3) not used
 - 4) that in a received DT DLPDU addressed to a PEER DLCEP,
 - i) the length and number of the DL-address(es) is as expected (only LONG; or only SHORT; or either SHORT or VERY-SHORT at the sender's option), and
 - ii) when two addresses are expected, that the second DL-address of the DLPDU is the DLCEP-address of the remote peer of the DLCEP addressed by the DT DLPDU's first DL-address.

If this validation fails, then

 - iii) if the DLCEP is PEER DLCEP, the DLE shall disconnect the DLCEP from the DLC as specified in IEC 61158-4-1, 8.2.1.8, with a reason of "provider-originated disconnection—wrong DLPDU format or parameters, permanent condition",
 - iv) else the DLE shall discard the DT DLPDU.
- c) If the DLCEP is a PEER DLCEP whose negotiated residual-activity attribute is TRUE, then the DLE shall restart the DLCEPs T_C (RAM) as specified in IEC 61158-4-1, 8.2.2.14.
- d) If the remaining number of octets in the DLPDU is less than the number of octets in the negotiated SD-parameters format for the applicable sender-to-receiver direction of transmission, then
- 1) if the DLCEP is PEER or SUBSCRIBER DLCEP, then the DLE shall disconnect the DLCEP from the DLC as specified in IEC 61158-4-1, 8.2.1.8, with a reason of "provider-originated disconnection—wrong DLPDU format or parameters, permanent condition",
 - 2) else the DLE shall discard the DT DLPDU.

Otherwise the DLE shall parse and process the applicable-format SD-parameters from those remaining octets as specified in IEC 61158-4-1, 8.2.2.5; and if the remaining number of octets in the DLPDU, after the SD-parameters, is greater than zero, then the DLE shall process that user-data as specified in IEC 61158-4-1, 8.2.2.6 and possibly 8.2.2.7.

5.2.2.2.4.24 IEC 61158-4-1, 8.2.2.10

NOTE The following procedures are either not included or partially included for the following reasons:
 IEC 61158-4-1, 8.2.2.10(a), only CLASSICAL or DISORDERED peer DLCEP are included for DL-Data request,
 IEC 61158-4-1, 8.2.2.10(d), this profile does not include DLC reset.

The timer T_U (MCD) shall be started when the DLS-user issues the corresponding DL-DATA request. It shall be cancelled at a CLASSICAL or DISORDERED peer DLCEP, when the DLE issues the corresponding DL-DATA confirm.

If the timer T_U (MCD) expires on a DL-DATA request, then the DLE shall

- a) not used
- b) remove the request from the sending DLCEP-address's user-request queue, Q_A (UR), and terminate processing of the request;
- c) maintain any appropriate DL-management statistics;
- d) if a DL-DATA confirm primitive for the request has not yet been issued, then:
 - 1) initiate a DL-DATA confirm reporting "provider-originated failure—request timeout"; and
 - 2) disconnect the DLCEP as specified in IEC 61158-4-1, 8.2.1.8.

5.2.2.2.4.25 IEC 61158-4-1, 8.2.2.11.0

NOTE 1 The following procedures are either not included or partially included for the following reasons:
 This profile does not include DLSDU with more than one segment.

NOTE 2 This timer is used only by peer DLCEPs whose sending data delivery features are DISORDERED or CLASSICAL.

The timer $T_{C,K}(SS)$ shall be started whenever a DLPDU containing all or part of $DLSDU_K$ is transmitted and $V_{C,K}(SS)$ is empty; it shall be cancelled whenever $V_C(A)$ is greater than or equal to K or whenever $V_{C,K}(SS)$ becomes non-empty IEC 61158-4-1, 8.2.2.5.2(b).

The duration of this timer shall be based on the local user-specified maximum confirm delay for DL-DATA primitives. If the specified value was other than UNLIMITED, then the duration of this timer should be between 12,5 % and 25 % of $V_c(NP).MCD_D$; otherwise the duration should be between 12,5 % and 25 % of 60 s. DL-management may override these preferred durations.

If the timer $T_{C,K}(SS)$ expires, then the DLE shall

- a) modify the variable $V_{C,K}(SS)$ to indicate that the K 'th $DLSDU$ need retransmission; and
- b) append to the DLEs unscheduled-service queue, $Q(US)$, a reference to the DLCEPs $Q_A(UR)$, to schedule a retransmission of the unacknowledged $DLSDU$; and
- c) maintain any appropriate DL-management statistics.

5.2.2.2.4.26 IEC 61158-4-1, 8.2.2.11.1

NOTE The following procedures are either not included or partially included for the following reasons: This profile does not include $DLSDU$ with more than one segment.

When the permission of IEC 61158-4-1, 6.7.4.9.1, is employed, the following rules apply:

- a) The timer $T_C(SS)$ shall be started, but not restarted, whenever a DLPDU containing all or part of $DLSDU_K$ is transmitted and $V_{C,K}(SS)$ is empty. The timer shall be restarted whenever it is not running and $V_C(A)$ is less than $V_C(M)$; it shall be cancelled whenever $V_C(A)$ equals $V_C(M)$ or whenever $V_{C,K}(SS)$ becomes non-empty due to receipt of a request for retransmission IEC 61158-4-1, 8.2.2.5.2(b).
- b) The duration of this timer shall be based on the local user-specified maximum confirm delay for DL-DATA primitives. If the specified value was other than UNLIMITED, then the duration of this timer should be between 25 % and 50 % of $0,5 \times V_c(NP).MCD_D$; otherwise the duration should be between 25 % and 50 % of 60s. DL-management may override these preferred durations.

If the timer $T_C(SS)$ expires, then the DLE shall

- c) modify the variable $V_{C,K}(SS)$, for the unacknowledged $DLSDU_K$ with the lowest sequence number, to indicate that the K 'th $DLSDU$ need retransmission;
- d) append to the DLEs unscheduled-service queue, $Q(US)$, a reference to the DLCEPs $Q_A(UR)$, to schedule a retransmission of the unacknowledged $DLSDU$; and
- e) maintain any appropriate DL-management statistics.

5.2.2.2.4.27 IEC 61158-4-1, 8.2.2.13

NOTE The following procedures are either not included or partially included for the following reasons: IEC 61158-4-1, 8.2.2.13(b): this profile does not include residual activity for multipeer DLC.

When applicable (see IEC 61158-4-1, 4.7.4.16, for the conditions of the timer's use), the timer $T_C(RAS)$ shall be started

- a) at a sending DISORDERED or CLASSICAL PEER DLCEP, whenever it is not running and when $V_C(A)$ equals $(V_C(N) - 1)$.
- b) not used.

The duration of this timer shall be based on the user-specified maximum confirm delay for DL-CONNECT request or response primitives. If the specified value was other than UNLIMITED, then the duration of this timer should be between 70 % and 95 % of $V_c(NP).MCD_CRS/2$;

otherwise the duration should be between 70 % and 95 % of 30 s. DL-management may override these preferred durations.

It shall be cancelled whenever $V_C(A)$ is not equal to $(V_C(N) - 1)$. If the timer $T_C(RAS)$ expires, then the DLE shall check for a reference to the DLCEP on the DLEs unscheduled-service queue, $Q(US)$, and if not found then append a reference to the DLCEP to the DLEs unscheduled-service queue, $Q(US)$, to schedule a transmission to the remote DLCEP(s).

5.2.2.2.4.28 IEC 61158-4-1, 8.2.2.14

When applicable (see IEC 61158-4-1, 4.7.4.17, for the conditions of the timer's use), the timer $T_C(RAM)$ shall run continuously. It shall be restarted whenever any DLPDU is received on the DLCEP.

The duration of this timer shall be based on the remote user-specified maximum confirm delay for DL-CONNECT request or response primitives and conveyed in an EC DLPDU previously-received from the sending DLCEP. If the specified value was UNLIMITED, then the duration of this timer should be 60 s. Otherwise, the duration should be $V_C(NP).MCD_CRS$. DL-management may override these preferred durations.

If the timer $T_C(RAM)$ expires, then the DLE shall disconnect the DLCEP as specified in IEC 61158-4-1, 8.2.1.8.

5.2.2.2.4.29 IEC 61158-4-1, 8.3

Table 81 specifies the selection of the subclauses for this profile.

Table 81 – CP 1/1: DLL protocol selection of 8.3

Clause	Header	Presence	Constraints
8.3.1	Operation of the connectionless data transfer with local-DLE-confirmation service	—	—
8.3.1.1	Receipt of a DL-UNITDATA request primitive not specifying remote-DLE-confirmation	Partial	Item d.2)i) is not included in this profile because the scheduling is always IMPLICIT for this profile
8.3.1.2	Transmission of a unitdata DT DLSDU	YES	—
8.3.1.3	Receipt of a DT DLPDU, with an explicit source address, addressed to a DL(SAP)-address	Partial	Item a) is not included in this profile because the DLSAP-role is limited to BASIC or GROUP.
8.3.1.4	Expiration of the timer $T_U(MCD)$ on a DL-UNITDATA request not specifying remote-DLE-confirmation	YES	—
8.3.2	Operation of the connectionless data transfer service with remote-DLE-confirmation (including all of subclauses)	NO	Remote-DLE confirmation is not included in this profile
8.3.3	Operation of the connectionless data exchange service (including all subclauses)	NO	DL-Unitdata exchange is not included in this profile
8.3.4	Operation of the listener query service (including all of subclauses)	NO	DL-Listener Query is not included in this profile

5.2.2.2.4.30 IEC 61158-4-1, 8.4

Table 82 specifies the selection of the subclauses for this profile.

Table 82 – CP 1/1: DLL protocol selection of 8.4

Clause	Header	Presence	Constraints
8.4.1	Operation of the DL-time service	—	—
8.4.1.1	Receipt of a DL-TIME request primitive	YES	—
8.4.1.2	Transmission of a TD DLPDU	YES	—
8.4.1.3	Receipt of a TD DLPDU	Partial	See 5.2.2.2.4.31
8.4.1.3.1	Additional actions required of a bridge	Partial	See 5.2.2.2.4.32
8.4.1.4	Receipt of an RQ DLPDU	YES	—
8.4.1.5	Receipt of an RR DLPDU	YES	—
8.4.1.6	Expiration of the timer T(TDP)	YES	—
8.4.2	Operation of the compel-service service	—	—
8.4.2.1	Receipt of a DL-COMPEL-SERVICE request primitive	Partial	See 5.2.2.2.4.33
8.4.3	Operation of the sequence scheduling service	NO	—
8.4.4	Operation of the subsequence selection service	NO	—
8.4.5	Implicit scheduling of DLS-user requests	YES	—

5.2.2.2.4.31 IEC 61158-4-1, 8.4.1.3

All of IEC 61158-4-1, 8.4.1.3, except the following subclauses, are included in this profile:

- e)4)ii), because this profile does not use the link-id of the source of time distribution of periodic scheduled activities in IEC 61158-4-1, 9.3.5.1(j); and
- e)5)ii), because this profile does not use the periodic schedule DL-time base (T0) in IEC 61158-4-1, 9.3.5.1(k).

5.2.2.2.4.32 IEC 61158-4-1, 8.4.1.3.1

All of IEC 61158-4-1, 8.4.1.3.1, except following subclauses, are included in this profile:

- a)2), because this profile does not use the periodic schedule DL-time base (T0) in IEC 61158-4-1, 9.3.5.1(k); and
- a)3), because this profile does not use the link-id of the source of time distribution of periodic scheduled activities in IEC 61158-4-1, 9.3.5.1(j).

5.2.2.2.4.33 IEC 61158-4-1, 8.4.2.1

NOTE The following procedures are either not included or partially included for the following reasons:
 IEC 61158-4-1, 8.4.2.1(a), (a.1): this profile includes this service only for local publisher DLCEP, which is bound to a sending buffer,
 IEC 61158-4-1, 8.4.2.1(a.2.ii.A), (b.1.i): this profile does not include scheduled sequence in the DLE,
 IEC 61158-4-1, 8.4.2.1(b), (b.1): this profile includes this service only for remote publisher DLCEP,
 IEC 61158-4-1, 8.4.2.1(c): this profile does not include this service for DLSAP-address.

When the DLE receives a DL-COMPEL-SERVICE request, it shall classify the request and take the appropriate corresponding action. If the request is for

- a) a local (to the DLE) publisher DLCEP, for which the DL-scheduling-policy is EXPLICIT, then
 - 1) not used
 - 2) If the DL-address is bound to a sending buffer, then the DLE shall

- i) modify the variable $V_{C,K}(SS)$, for the appropriate K corresponding to the DLSDU currently associated with the buffer, to indicate that the DLSDU requires transmission,
 - ii) form a reference to the $Q_A(UR)$ of the specified local peer or publisher DLCEP, at the DLCEPs priority, where the reference indicates the need to send a DLSDU from the sending buffer identified in (2), and append the reference to
 - A) not used
 - B) the DLEs unscheduled-service queue, $Q(US)$;
 - iii) not used
 - iv) return an immediate status of “success”.
- b) the remote publisher DLCEP of a local subscriber DLCEP, then the DLE shall
- 1) form a reference to the $Q_A(UR)$ of the specified local subscriber DLCEP, at the DLCEPs priority, where the reference indicates the need to compel the transmission of a DLSDU from the remote correspondent publisher DLCEP identified in (b), and append the reference to
 - i) not used;
 - ii) the DLEs unscheduled-service queue, $Q(US)$;
 - 2) return an immediate status of “success”;
- c) not used
- some other DL-address, then the DLE shall return an immediate status of “user failure—invalid DL-address”.

5.2.2.2.5 IEC 61158-4-1, Clause 9

5.2.2.2.5.1 General

Table 83 specifies the selection of the subclauses for this profile.

Table 83 – CP 1/1: DLL protocol selection of Clause 9

Clause	Header	Presence	Constraints
9.1	Scope	Partial	Includes (a), (b) and (d), but does not include (c), because the DL-SUBSCRIBER-QUERY request and DL-LISTENER-QUERY request are not included in this profile, and bridges do not use SPDUs for forwarding-database maintenance
9.2	Overview of LAS operation	Partial	Includes (a) to (e), but does not include (f) and (g)
9.3	DL-support subprotocol definition	Partial	See 5.2.2.2.5.2
9.4	Elements of Procedures for receiving SPDUs	NO	—

5.2.2.2.5.2 IEC 61158-4-1, 9.3

The DL-support subprotocol defines Support Protocol Data Unit (SPDU) encodings to support the needs of LAS operation, including scheduling and other DLE functions.

Any DLPDU sent to, or by, the DL-support functions within a DLE, including any DLPDU addressed to a NODE DL-address, which has a non-null user-data field, shall contain as “user data” a single SPDU whose encoding and interpretation is as described in IEC 61158-4-1, 9.3. This requirement includes any DLPDU addressed to a DLSAP-address designating LAS functionality, such as link-local DL-address 0400₁₆. It also includes any PR or TL DLPDU, both of which always have a user-data field.

See Table 84 for selection of subclauses.

Table 84 – CP 1/1: DLL protocol selection of 9.3

Clause	Header	Presence	Constraints
9.3.1	Common definitions	YES	—
9.3.2	Link-maintenance SPDUs	—	—
9.3.2.1	Probe-response SPDU	Partial	See 5.2.2.2.5.3
9.3.2.2	Node-activation SPDU	Partial	See 5.2.2.2.5.4
9.3.2.3	LAS-data-base-status SPDU	Partial	See 5.2.2.2.5.5
9.3.2.4	Live-list-change SPDU	Partial	See 5.2.2.2.5.6
9.3.2.5	Live-list-request SPDU	YES	—
9.3.2.6	Live-list-detail SPDU	Partial	This profile includes all of fields of the live-list-detail SPDU, except DLE-type as specified in (g) of the referenced subclause
9.3.2.7	DL-conformance-query SPDU	NO	—
9.3.2.8	DL-conformance-reply SPDU	NO	—
9.3.2.9	Link-basic-parameters-request SPDU	NO	—
9.3.2.10	Link-basic-parameters-reply SPDU	NO	—
9.3.2.11	Link-master-parameters-request SPDU	NO	—
9.3.2.12	Link-master-parameters-reply SPDU	NO	—
9.3.2.13	Token-hold-time-request SPDU	NO	—
9.3.2.14	Token-hold-time-array SPDU	NO	—
9.3.2.15	FDC-DLE-has-“awakened” SPDU	NO	—
9.3.2.16	FDC-DLE-may-“go-to-sleep”-notification SPDU	NO	—
9.3.2.17	FDC-DLE-may-“go-to-sleep”-acknowledge SPDU	NO	—
9.3.3	LAS-transfer SPDUs	—	—
9.3.3.1	Relinquish-LAS-role-request SPDU	YES	—
9.3.3.2	Accept-LAS-role-request SPDU	NO	—
9.3.3.3	Accept-LAS-role-reply SPDU	NO	—
9.3.4	Schedule-construction SPDUs	NO	—
9.3.5	Schedule-transfer SPDUs	Partial	See 5.2.2.2.5.7
9.3.6	Non-LAS SPDUs	NO	—

5.2.2.2.5.3 IEC 61158-4-1, 9.3.2.1

NOTE N = 0, F = 0.

This profile includes all the Probe-response SPDU subclauses, but the values of some of the fields are fixed by this profile to following:

- a) as required
- b) as required
- c) Octets 3 and 4 shall specify, as depicted in IEC 61158-4-1, Table 83:
 - 1) the DLEs lack of need for token circulation without an explicit request, encoded as a Boolean, N: 0 (no, token circulation is needed);
 - 2) that the DLE does not report its functional class, encoded as CC = 0;
 - 3) whether the DLE will function as an FDC DLE which can be expected to be non-responsive to some live-list link-maintenance queries, and whether that DLE should be

included in the expected-non-response list, V(ENRL) IEC 61158-4-1, 4.7.5.4, encoded as a Boolean, F:0 (the DLE will not function as an FDC DLE).

5.2.2.2.5.4 IEC 61158-4-1, 9.3.2.2

This profile includes all the node-activation SPDU subclauses, but the values of some of the fields are fixed by this profile to following:

V(MRC) = 0;

V(NRC) = 0; and

V(NDL) = 0.

5.2.2.2.5.5 IEC 61158-4-1, 9.3.2.3

NOTE T = 0, D = 0, S = 1.

This profile includes all the LAS-data-base-status SPDU subclauses, but the values of some of the fields are fixed by this profile to following:

- a) as required
- b) Octet 2 shall specify, as depicted in IEC 61158-4-1, Table 87:
 - 1) the LASs capability to transfer its schedule, T, encoded as a Boolean: 0 (no, LAS is not capable);
 - 2) as required
 - 3) whether all or part of the active schedule is has been dynamically constructed by the LAS, D, encoded as a Boolean: 0 (no);
 - 4) whether all or part of the active schedule has been statically constructed by DL-management, S, encoded as a Boolean: 1 (yes).

5.2.2.2.5.6 IEC 61158-4-1, 9.3.2.4

NOTE N = 0, F = 0, SS = 01 or 11

This profile includes all the Live-list-change SPDU subclauses, but the values of some of the fields are fixed by this profile to following:

- a) as required
- b) as required
- c) The remainder of the SPDU is an array of two octet members specifying DLE-status and structured as shown in IEC 61158-4-1, Table 89:
 - 1) as required
 - 2) The second octet of each member shall specify the status of the DLE, encoded as:
 - i) N, the DLEs non-need for token circulation, always encoded as 0;
 - ii) F, whether the DLE is an FDC DLE, always encoded as 0;
 - iii) as required
 - iv) SS, the last-observed status of that DLE, encoded as
 - 01: not present; or
 - 11: present and awake.

5.2.2.2.5.7 IEC 61158-4-1, 9.3.5

In IEC 61158-4-1, 9.3.5, the schedule-transfer SPDUs convey link schedule from LAS DLE to a non-LAS DLE on the same link. In this profile, the same SPDUs are used to transfer link schedule via network management protocol. These SPDUs are transported in a domain using FMS domain download. It is permitted to transfer more than one SPDU in one FMS PDU. The

format of each SPDU is such that the octets comprising each SPDU can be determined without any ambiguity.

All of the paragraphs of IEC 61158-4-1, 9.3.5, except the first paragraph are included in this profile.

See Table 85 for selection of subclauses.

Table 85 – CP 1/1: DLL protocol selection of 9.3.5

Clause	Header	Presence	Constraints
9.3.5.1	Schedule-summary SPDU	Partial	See 5.2.2.2.5.8
9.3.5.2	Sub-schedule SPDU	—	—
9.3.5.2.0	—	YES	—
9.3.5.2.1	Sequence sub-SPDU	Partial	See 5.2.2.2.5.9
9.3.5.2.2	Element	Partial	See 5.2.2.2.5.10
9.3.5.3	Schedule-summary-request SPDU	NO	—
9.3.5.4	Sub-schedule-request SPDU	NO	—

5.2.2.2.5.8 IEC 61158-4-1, 9.3.5.1

NOTE 1 V(TSL) and T0 are not used.

This profile includes all schedule-summary SPDU subclauses in the format specified in IEC 61158-4-1, 9.3.5.1, but does not use V(TSL) and periodic schedule DL-time base (T0) fields of this SPDU. Therefore, in this profile, IEC 61158-4-1, 9.3.5.1(j) and (k), are replaced as shown in the following:

- a) as required
- b) as required
- c) as required
- d) as required
- e) as required
- f) as required
- g) as required
- h) as required
- i) as required
- j) Octets 15 and 16 are not used and can be set to any value
- k) Octets 17 to 22 are not used and can be set to any value.
- l) as required
- m) as required
- n) as required

NOTE 2 The starting DL-time, (T0), of all periodic sub-schedules in this schedule is fixed to a zero value of (DL-time – V(DLTO)). Therefore, the starting time of a macro-cycle in the schedule is given by:

$$(DL-time - V(DLTO)) = V(LSTO) + C(NT) = N \times \text{macro-cycle duration, where } N \text{ is a non-negative integer.}$$

5.2.2.2.5.9 IEC 61158-4-1, 9.3.5.2.1

IEC 61158-4-1, 9.3.5.2.1 is included in this profile, except for (a) which is replaced by:

- a) The starting time of the schedule is fixed as specified in IEC 61158-4-1, 9.3.5.1(k). Therefore, the starting time of a sequence is given by:
 $(DL\text{-time} - V(DLTO)) = V(LSTO) + C(NT) =$
 $N \times \text{macro-cycle duration} + M \times (\text{sub-schedule period}) + \text{scheduled-starting-time-offset},$
 where N and M are non-negative integers.

5.2.2.2.5.10 IEC 61158-4-1, 9.3.5.2.2

NOTE This profile includes only CD-request, short DL-address. Therefore, the parts of IEC 61158-4-1, 9.3.5.2.2 included in this profile are as follows.

The element is the lowest level component of the schedule, and it represents a transaction IEC 61158-4-1, 3.4.10. The element shall be encoded as specified in Table 86. Multi-octet values shall be encoded with the most significant octet of the value encoded in the lowest-index octet of the multi-octet field.

Table 86 – CP 1/1: DLL protocol selection of 9.3.5.2.2, replacement for element encoding

Octet index	Contents of subfield
1	Element-type
2	Element-parameter
...	

- a) Octet 1 shall specify the type of transaction and shall be encoded as:
 1011 00PP — CD-request, SHORT DL-address, PP = priority IEC 61158-4-1, 5.2.1.3;
- b) Octet 2 and up shall specify the parameters for the element. The length and encoding depends upon the element-type.
- 1) If the element type is CD-request, SHORT DL-address, then the element parameter shall have two octets and these two octets, octet 2 and 3 shall specify a SHORT DLCEP-address.

5.2.2.2.6 IEC 61158-4-1, Clause 10

5.2.2.2.6.1 General

Table 87 specifies the selection of subclauses for this profile.

Table 87 – CP 1/1: DLL protocol selection of Clause 10

Clause	Header	Presence	Constraints
10.0	—	YES	—
10.1	DLE initialization	YES	—
10.2	LAS behaviour and operation	Partial	See Table 88
10.3	DL-support operation	Partial	See 5.2.2.2.6.4
10.4	DL-bridge elements of procedure and bridge sub-protocol	Partial	See 5.2.2.2.6.11
10.5	DL-management-information	Partial	See 5.2.2.2.6.12
10.6	Implementation profiles	Partial	See 5.2.2.2.6.13

Table 88 – CP 1/1: DLL protocol selection of 10.2

Clause	Header	Presence	Constraints
10.2.1	LAS operation when holding a scheduler token	Partial	All of the referenced subclause, except (b.2), are included in this profile; because the ES DLPDU is not part of this profile
10.2.2	Return of a delegated token; assumption of a scheduler token	Partial	All of the referenced subclause are included in this profile, except paragraph 2 (including items a), b), 1) and 2)), because the ES DLPDU is not part of this profile
10.2.3	Receipt of a probe-response (PR) SPDU	YES	—
10.2.4	Lack of response to a PT DLPDU	YES	—
10.2.5	Receipt of a live-list-request SPDU	YES	—
10.2.6	Receipt of a relinquish-LAS-role-request SPDU	YES	See 5.2.2.2.6.2 for additional text
10.2.7	Other link-maintenance requirements	YES	See 5.2.2.2.6.3 for additional text
10.2.8	Receipt of a link-master-parameters-request SPDU	NO	Link master parameters are distributed by the NM protocol
10.2.9	Receipt of a token-hold-time-request SPDU	NO	Token-hold-time array is distributed by the NM protocol
10.2.10	Receipt of a schedule-summary-request SPDU	NO	Schedule-summary is distributed by the NM protocol
10.2.11	Receipt of a sub-schedule-request SPDU	NO	Sub-schedules are distributed by the NM protocol

5.2.2.2.6.2 IEC 61158-4-1, 10.2.6

In this profile the LAS shall also ignore the received SPDU if

- a) the DLE has been instructed by the DLME to be the Primary Link master (that is, the preferred LAS), and
- b) the node-designator of the DLE requesting the transfer (that is, the node-designator of the DL-source address of the conveying DLPDU) has a higher numeric value than the node designator of this LM DLE (which is currently acting as LAS).

NOTE This extension provides for explicit management selection of the DLE that will provide the LAS role.

5.2.2.2.6.3 IEC 61158-4-1, 10.2.7

Whenever there is a change in the value of V(FUN) or V(NUN), the LAS DLE shall respond as in IEC 61158-4-1, 10.2.5, to notify the other LMs on the link of this parameter change.

5.2.2.2.6.4 IEC 61158-4-1, 10.3

All of the paragraphs of IEC 61158-4-1, 10.3, except (a), (b), (c), (k) and (m) to (v), are included in this profile.

See Table 89 for selection of subclauses.

Table 89 – CP 1/1: DLL protocol selection of 10.3

Clause	Header	Presence	Constraints
10.3.1	Receipt of an LAS-database-status SPDU by an LM DLE	Partial	See 5.2.2.2.6.5
10.3.2	Receipt of a live-list-change SPDU by an LM DLE	YES	—
10.3.3	Receipt of a live-list-detail SPDU by an LM DLE	Partial	All of the subclause, except “—the expected-non-response-list, V(ENRL),” is included in this profile, because V(ENRL) is not part of this profile
10.3.4	Request for LAS parameters by an LM DLE	Partial	See 5.2.2.2.6.6
10.3.5	Receipt of a link-master-parameter-reply SPDU by an LM DLE	Partial	See 5.2.2.2.6.7
10.3.6	Receipt of a token-hold-time-array SPDU by an LM DLE	NO	Token-hold-time array is distributed by the NM protocol
10.3.7	Receipt of a schedule-summary SPDU by an LM DLE	Partial	See 5.2.2.2.6.8 for the replacement text for IEC 61158-4-1, 10.3.7
10.3.8	Receipt of a sub-schedule SPDU by an LM DLE	Partial	See 5.2.2.2.6.9 for the replacement text for IEC 61158-4-1, 8.3.8
10.3.9	Request for LAS transfer by an LM DLE	Partial	See 5.2.2.2.6.10

5.2.2.2.6.5 IEC 61158-4-1, 10.3.1

The first paragraph and its bullets only are included in this profile. The second paragraph, beginning “The receiving LM DLE shall compare the schedule version-number ...”, and its bullets are not included in this profile, because the schedule is distributed via the Network Management protocol.

5.2.2.2.6.6 IEC 61158-4-1, 10.3.4

NOTE Only the parts of IEC 61158-4-1, 10.3.4 that are included in this profile are given in 5.2.2.2.6.6. Other parts are not included in this profile, because the link master receives all parameters, except V(LL) via NM protocol.

A link master requires the following parameters to operate as the LAS:

- a) the local link’s configuration parameters defined in IEC 61158-4-1, 6.7.5;
- b) the local-link-live-list, V(LL);
- c) not used
- d) the token-circulation-list, V(TCL);
- e) the maximum-token-holding-time-array, V(MTHA);
- f) the local link’s schedule; and
- g) a sense of the current LAS DLEs DL-time.

If a link master DLE does not have the necessary parameters required to operate as the LAS, as may be the case when the link master DLE has just changed its state to ONLINE, then the link master DLE shall schedule the transmission of the following SPDU to the local LAS in connectionless DT DLPDUs each with format 1S, NORMAL priority, a destination address of 0400₁₆, and a source address of V(TN).00:

— a live-list-request SPDU IEC 61158-4-1, 9.3.2.5, and

the link-master DLE shall note the need to transmit a CT DLPDU at its first opportunity.

After sending the SPDU, the sending DLE shall wait for reception of the live-list-detail SPDU.

If this SPDU is not received within fifteen receptions of a PT DLPDU with a token-use-subfield equal to RESTART, then the requesting LM DLE shall again schedule the transmission of the appropriate request SPDU for the missing reply SPDU.

5.2.2.2.6.7 IEC 61158-4-1, 10.3.5

NOTE The link master parameters are received via the NM protocol, but it is necessary to perform the check described in 5.2.2.2.6.7. Only the parts of IEC 61158-4-1, 10.3.5 that are included in this profile are reprinted here.

If the DLEs maximum-inactivity-to-claim-LAS-delay is less than or equal to the link's configured value of maximum-inactivity-to-claim-LAS-delay, V(MICD), then the DLE shall note that it is capable of operating as the local link's LAS.

5.2.2.2.6.8 IEC 61158-4-1, 10.3.7

NOTE The schedule-summary is received via NM protocol in a FMS domain download, but it is necessary to perform the check described in 5.2.2.2.6.8.

If the schedule version-number field of the received schedule-summary (see IEC 61158-4-1, 9.3.5.1) is non-zero, then

- a) if either the DLE has no link schedule, or the schedule version-number of the link schedule stored in the specified domain is different than the schedule version-number field of the just received schedule-summary, and either the receiving DLE is not an LAS DLE, or the previously stored schedule in the specified domain is not active, then the DLE shall
 - 1) check that it is capable of executing the link schedule whose summary was just received. The DLE shall
 - i) check that it has the capability to execute the number of sub-schedules in the schedule-summary, otherwise the DLE shall notify the local DL-management with the error "number of sub-schedules exceeds the capability" as specified in Table 90;
 - ii) check that the DLEs value of maximum-scheduling-overhead, V(MSO), IEC 61158-4-1, 4.7.5.6 is less than or equal to the value of V(MSO) specified in the schedule-summary, otherwise the DLE shall notify the local DL-management with the error "required maximum-scheduling-overhead exceeds the capability" as specified in Table 90;
 - iii) check that the DLE has the required storage capacity specified in the schedule-summary, otherwise the DLE shall notify the local DL-management with the error "not enough storage capacity" as specified in Table 90;
 - iv) check that the DLE has the required timing resolution specified in the schedule-summary, otherwise the DLE shall notify the local DL-management with the error "required timing resolution exceeds the capability" as specified in Table 90;
 - v) check that the link's configured value of $V(MRD) \times V(ST)$ is less than or equal to the value specified in the schedule-summary, otherwise the DLE shall notify the local DL-management with the error "required response-delay larger than the link's configured value" as specified in Table 90;

If any of these checks fail, then the DLE shall discard the just received schedule-summary.

- 2) Otherwise, when these checks are all passed, then the DLE shall update the Network Management variables associated with the just received schedule-summary.
- b) Otherwise, when the receiving DLE is an LAS DLE and the previously stored schedule in the specified domain is active, then the DLE shall discard the just received schedule-summary, and the DLE shall notify the local DL-management with the error "specified domain is active" as specified in Table 90.
- c) Otherwise, when the DLE has a link schedule stored in the specified domain and the version-number of that link schedule is equal to the schedule version-number field of the just received schedule-summary, then the DLE shall discard the just received schedule-

summary, and the DLE shall notify the local DL-management with the error “specified schedule already exists” as specified in Table 90.

Otherwise, when the schedule version-number field of the just received schedule-summary is zero, then the DLE shall record that there is no link schedule in the specified domain and the DLE shall update the Network Management variables associated with the just received schedule-summary.

If the LM DLE discards the just received schedule-summary, then it shall return an error to local DL- management, specifying the reason for discard. The errors (and their suggested coding) are listed in Table 90.

Table 90 – CP 1/1: DLL protocol selection of 10.3.7, specification of errors

Error	Description
1	Specified domain is active
2	Number of sub-schedules exceeds the capability
3	Required maximum-scheduling-overhead exceeds the capability
4	Not enough storage capacity
5	Required timing resolution exceeds the capability
6	Required response-delay larger than the link’s configured value
7	Specified schedule already exists
8	Sub-schedule reference inconsistent with schedule-summary
9	Schedule version-number in sub-schedule inconsistent with schedule-summary

5.2.2.2.6.9 IEC 61158-4-1, 10.3.8, receipt of a sub-schedule SPDU by an LM DLE

NOTE The sub-schedule is received via the NM protocol in a FMS domain download, but it is necessary to perform the procedure described in 5.2.2.2.2.9.

If the schedule version-number field of the just received sub-schedule IEC 61158-4-1, 9.3.5.2 is equal to the schedule version-number field of the last received schedule-summary IEC 61158-4-1, 9.3.5.1 for the same domain, then

- a) If the sub-schedule identifier field of the received sub-schedule is equal to a sub-schedule-SPDU reference included in the last received schedule-summary for the same domain, then the DLE shall store the sub-schedule as part of the link schedule.
- b) Otherwise, when the sub-schedule identifier field of the received sub-schedule is equal to zero, then the DLE shall discard the just received sub-schedule.
- c) Otherwise, when the sub-schedule identifier field of the received sub-schedule is neither equal to zero nor equal to a sub-schedule-SPDU reference included in the last received schedule-summary for the same domain, then the DLE has received a sub-schedule inconsistent with the DLEs last-received schedule-summary. Therefore the DLE shall discard the entire schedule for the specified domain and the DLE notify the local DL-management with the error “sub-schedule reference inconsistent with schedule-summary” as specified in Table 90.
- d) Otherwise, when the schedule version-number field of the just received sub-schedule is not equal to the schedule version-number field of the last received schedule-summary for the same domain, or if the DLE had never received a schedule-summary for that domain, then the DLE shall discard the entire schedule for the specified domain the DLE notify the local DL-management with the error “schedule version-number in sub-schedule inconsistent with schedule-summary” as specified in Table 90.

5.2.2.2.6.10 IEC 61158-4-1, 10.3.9, request for LAS transfer by an LM DLE

IEC 61158-4-1, 10.3.9 is included in this profile, but with items (e) and (f) replaced by the following single item:

if a TL DLPDU is received, but is rejected as specified in IEC 61158-4-1, 6.20.4.2, then the LM DLE shall inform local DL-management of this failure.

NOTE The data structures of Schedule, Sub-schedule, Sequence and Element are such that one can construct these with zero instances of Sub-schedule, Sequence and Element. Therefore, a completely empty schedule can be downloaded, but will amount to no sequence. Empty schedules, subschedules, and sequences are allowed.

5.2.2.2.6.11 IEC 61158-4-1, 10.4

The first paragraph immediately after IEC 61158-4-1, 10.4 is not included in this profile. Table 91 specifies the selection of the subclauses for this profile.

Table 91 – CP 1/1: DLL protocol selection of 10.4

Clause	Header	Presence	Constraints
10.4.1	Common features of the Type 1 bridge protocols and elements of procedure	Partial	Only subclauses (a), (b) and (c) are included in this profile
10.4.1.1	Introduction	Partial	Subclauses (d) and (e) are not included in this profile
10.4.1.2	Extent of specification	YES	—
10.4.1.3	Support of the DLL service	YES	—
10.4.1.4	Principles of operation	—	—
10.4.1.4.0	—	YES	—
10.4.1.4.1	Bridge operation	YES	—
10.4.1.4.2	Bridge Architecture	—	—
10.4.1.4.2.0	—	YES	—
10.4.1.4.2.1	Bridge management entity (BME)	YES	—
10.4.1.4.2.2	Root port determination	YES	—
10.4.1.4.2.3	Port state information	YES	—
10.4.1.4.2.4	Filtering database	Partial	All of the referenced subclause, except (c), (d), (e) and associated notes is included
10.4.1.4.2.5	Republishing database	YES	—
10.4.1.4.3	Addressing	YES	—
10.4.1.4.4	Statistics and diagnostic information	YES	—
10.4.1.5	Detailed conceptual model of bridge functions (informative)	YES	—
10.4.2	Adaptive bridge sub-protocol and elements of procedure	NO	—
10.4.3	Non-adaptive bridge sub-protocol and elements of procedure	YES	—

5.2.2.2.6.12 IEC 61158-4-1, 10.5 – DL-management-information

Table 92 specifies the selection of the subclauses for this profile.

Table 92 – CP 1/1: DLL protocol selection of 10.5

Clause	Header	Presence	Constraints
10.5.1	Scope	Partial	This annex enumerates the set of DL-parameters, defined as variables in IEC 61158-4-1, 5.7, which need to be preconfigured before proper DLE operation is possible
10.5.2	DLE configuration parameters	—	—
10.5.2.1	Node-specific DL-configuration parameters	YES	—
10.5.3	Additional node-independent DL-configuration parameters	Partial	Is included in this profile except for the assignments to the V(MRC), V(NRC), V(NDL) and V(MEP) parameters
10.5.4	Additional node-independent DL-configuration parameters for link-master class DLEs	Partial	Is included in this profile except for the assignments to the V(MRC), V(NRC), V(NDL), V(MEP) and V(MST) parameters
10.5.5	Additional node-independent DL-configuration parameters for bridge class DLEs	Partial	Is included in this profile except for the assignments to the V(MRC), V(NRC), V(NDL), V(MEP) and V(MST) parameters and all of the configuration parameters defined in ISO/IEC 15802-3
10.5.5.3	Node-independent Ph-configuration parameters required for minimal DL-communication	YES	—
10.5.6	DLE-collected fault-management data	—	—
10.5.6.1	Required statistical measures	—	—
10.5.6.1.1	Transmission-related statistical measures	Partial	Is included in this profile except for item b)
10.5.6.1.2	Reception-related statistical measures	Partial	Is included in this profile except for item e)
10.5.6.1.3	Additional reception-related statistical measures required of a bridge DLE	NO	—
10.5.6.2	Additional required DLE-collected fault-management data	YES	—
10.5.6.3	Additional statistical measures	YES	—
10.5.7	DLE Variables which can be read and set by DL—management	NO	—
10.5.8	DLE Actions Requestable by DL-management	NO	—

5.2.2.2.6.13 IEC 61158-4-1, 10.6

The profiles of IEC 61158-4-1, 10.6 and its subclauses apply. The values for this profile are given in Table 93.

Table 93 – CP 1/1: DLL protocol selection of 10.6

Clause	Header	Presence	Constraints
10.6.1	Support for Long address	YES	—
10.6.2 a)	Priorities	YES	Multi
10.6.2 b)	Data Delivery for Connection Mode	Partial	B, although this profile does not include Ordered and Unordered Peer DLC
10.6.2 c)	Subscriber to Publisher Data	NO	—
10.6.2 d)	DLSDU Segmentation ratio	Partial	1
10.6.2 e)	Timeliness	YES	All choices
10.6.2 f)	DL-Time stamp	NO	—
10.6.2 g)	Data Delivery for Connection-less	YES	Z
10.6.3 a)	Time synchronization class	Partial	Depends upon the device profile
10.6.3 b)	Request for time-based scheduling from DLS-user	NO	—
10.6.3 c)	LAS scheduling capability	YES	STATIC

5.2.3 Application layer**5.2.3.1 AL service selection**

Table 94 the selection of the Application layer services within IEC 61158-5-9.

Table 94 – CP 1/1: AL service selection

Clause	Header	Presence	Constraints
1	Scope	YES	—
2	Normative references	YES	—
3	Terms, definitions, symbols, abbreviations and conventions	YES	—
4	Concepts	YES	—
5	Data type ASE	—	See Table 95
6	Communication model type 9 specification	YES	—

Table 95 – CP 1/1: AL data type selection of Clause 4

Clause	Header	Presence	Constraints
5.1	Overview	YES	—
5.2	Formal Definition of Data Type Objects	YES	—
5.3	FAL Defined Data Types	YES	
5.3.1	Fixed Length Types	—	—
5.3.1.1	Boolean	YES	—
5.3.1.2	Integer8	YES	—
5.3.1.3	Integer16	YES	—
5.3.1.4	Integer32	YES	—
5.3.1.5	Unsigned8	YES	—
5.3.1.6	Unsigned16	YES	—
5.3.1.7	Unsigned32	YES	—
5.3.1.8	Floating Point	YES	—
5.3.1.9	Date	YES	—
5.3.1.10	TimeOfDay	YES	—
5.3.1.11	TimeDifference	YES	—
5.3.1.12	TimeValue	YES	—
5.3.2.1	VisibleString	YES	—
5.3.2.2	OctetString	YES	—
5.3.2.3	BitString	YES	—
5.4	Data type ASE Service Specification	YES	—
5.5	Summary of data types	YES	—

5.2.3.2 AL protocol selection

Table 96 specifies the AL protocol selection within IEC 61158-6-9.

Table 96 – CP 1/1: AL protocol selection

Clause	Header	Presence	Constraints
1	Scope	YES	—
2	Normative references	YES	—
3	Terms, definitions, symbols, abbreviations and conventions	—	—
4	Abstract syntax	YES	—
5	Transfer syntax	YES	—
6	Structure of FAL protocol state machines	YES	—
7	AP-Context state machines	YES	—
8	FAL Service Protocol Machine	YES	—
9	Application Relationship Protocol Machines	YES	—
10	DLL Mapping Protocol Machine	YES	—

5.3 Profile 1/2 (FOUNDATION™ HSE)

NOTE This profile supports communications through both local- and wide-area network infrastructures. It is readily obtainable as commercial off-the-shelf (COTS) technology.

5.3.1 Physical layer

Any appropriate physical layer(s) for ISO/IEC 8802-3 may be used. The specific physical layer options selected shall be documented in the statement of conformance.

5.3.2 Data-link layer

5.3.2.1 MAC sublayer

ISO/IEC 8802-3 shall be used. Any standard options selected shall be documented in the statement of conformance.

5.3.2.2 LLC sublayer

ISO/IEC 8802-2 shall be used. Any standard options selected shall be documented in the statement of conformance.

5.3.2.3 Security on LANs (optional)

Any standard options selected shall be documented in the statement of conformance.

5.3.3 Network layer

Internet standard RFC 791 (IP, Internet Protocol) and its amendments and successors shall be used. Any standard options selected shall be documented in the statement of conformance.

5.3.4 Transport layer

Internet standard RFC 768 (UDP, User Datagram Protocol) and its amendments and successors shall be used. Any standard options selected shall be documented in the statement of conformance.

Internet standard RFC 793 (TCP, Terminal Control Protocol) and its amendments and successors may be used. Any standard options selected shall be documented in the statement of conformance.

5.3.5 Application layer

5.3.5.1 AL service selection

Table 97 specifies the AL service selection within IEC 61158-5-5.

Table 97 – CP 1/2: AL service selection

Clause	Header	Presence	Constraints
1	Scope	YES	—
2	Normative references	YES	—
3	Terms and definitions	YES	—
4	Concepts	YES	—
5	Data type ASE	—	The same as CP1/1. See Table 95
6	Communication model specification	YES	—

5.3.5.2 AL protocol selection

Table 98 specifies the AL protocol selection within IEC 61158-6-5.

Table 98 – CP 1/2: AL protocol selection

Clause	Header	Presence	Constraints
1	Scope	YES	—
2	Normative references	YES	—
3	Terms, definitions, symbols, abbreviations and conventions	—	—
4	Abstract syntax	YES	—
5	Transfer syntax	YES	—
6	Structure of FAL protocol state machines	YES	—
7	AP-Context state machines	YES	—
8	FAL Service Protocol Machine	YES	—
9	Application Relationship Protocol Machines	YES	—
10	DLL Mapping Protocol Machine	YES	—

5.4 Profile 1/3 (FOUNDATION™ H2)

NOTE This profile is similar to 5.2, but with a different and more varied selection of physical layer data rates. It provides a migration path for existing CPF 5/1 installations, such that passive media components are unaffected by the migration.

5.4.1 Physical layer

Table 99 specifies the PhL selection for CP 1/3 H2 devices, using either 150 Ω twisted-pair or dual-fiber optical media.

Table 99 – CP 1/3: PhL selection for H2 devices

Clause	Header	Presence	Constraints
1	Scope	YES	—
2	Normative references	Partial	Used if needed
3	Terms and definitions	—	—
3.1	Common terms and definitions	Partial	Used when applicable
3.2	Type 1: Terms and definitions	YES	—
3.3 – 3.7	—	NO	—
4	Symbols and abbreviations	—	—
4.1	Symbols	—	—
4.1.1	Type 1: Symbols	YES	—
4.1.2 – 4.1.6	—	NO	—
4.2	Abbreviations	—	—
4.2.1	Type 1: Additional abbreviations	YES	—
4.2.2 – 4.2.6	—	NO	—
5	Data-link layer – Physical Layer interface	—	—
5.1	General	Partial	Used as needed
5.2	Type 1: Required services	YES	—
5.3 – 5.7	—	NO	—
6	Station Management – Physical Layer interface	—	—
6.1	General	Partial	Used as needed
6.2	Type 1: Station Management – Physical Layer interface	YES	—
6.3 – 6.7	—	NO	—
7	DCE Independent Sublayer (DIS)	—	—
7.1	General	Partial	Used as needed
7.2	Type 1: DIS	YES	—
7.3 – 7.5	—	NO	—
8	DTE – DCE interface	—	—
8.1	General	Partial	Used as needed
8.2	Type 1: DTE – DCE interface	YES	—
8.3 – 8.4	—	NO	—
9	Medium Dependent Sublayer (MDS)	—	—
9.1	General	Partial	Used as needed
9.2	Type 1: MDS: Wire and optical media	YES	—
9.3 – 9.8	—	NO	—
10	MDS – MAU interface	—	—
10.1	General	Partial	Used as needed
10.2	Type 1: MDS — MAU interface: wire and optical media	YES	—
10.3 – 10.6	—	NO	—
11	Type 1 and 7: Medium Attachment Unit: voltage mode, linear-bus-topology 150 Ω twisted-pair wire medium	YES	^a
12 – 14	—	NO	—
15	Type 1 and 7: Medium Attachment Unit: dual-fiber optical media	YES	^a
Next clauses	—	NO	—

Clause	Header	Presence	Constraints
Annex A	Type 1: Connector specification		
A.1	Internal Connector for wire medium	YES	^b
A.2	External Connectors for wire medium	YES	^b
A.3	External Connectors for optical medium	YES	^b
Next annexes	—	NO	—
^a The selection is an alternate solution. All selected solutions are required to operate at a single common data rate.			
^b The selection is an alternate solution, depending on the solution chosen from Clauses 11 or 15.			

Table 100 specifies the PhL selection for H2 media and related components, either for 150 Ω twisted-pair or for dual-fiber optical media.

Table 100 – CP 1/3: PhL selection for H2 media and related components

Clause	Header	Presence	Constraints
1	Scope	YES	—
2	Normative references	Partial	Used if needed
3	Terms and definitions	—	—
3.1	Common terms and definitions	Partial	Used when applicable
3.2	Type 1: Terms and definitions	YES	—
3.3 – 3.7	—	NO	—
4	Symbols and abbreviations	—	—
4.1	Symbols	—	—
4.1.1	Type 1: Symbols	YES	—
4.1.2 – 4.1.6	—	NO	—
4.2	Abbreviations	—	—
4.2.1	Type 1: Additional abbreviations	YES	—
4.2.2 – 4.2.6	—	NO	—
5 – 10	—	NO	—
11	Type 1 and 7: Medium Attachment Unit: voltage mode, linear-bus-topology 150 Ω twisted-pair wire medium	YES	^a
12 – 14	—	NO	—
15	Type 1 and 7: Medium Attachment Unit: dual-fiber optical media	YES	^a
Next clauses	—	NO	—
Annex A	Type 1: Connector specification		
A.1	Internal Connector for wire medium	YES	^b
A.2	External Connectors for wire medium	YES	^b
A.3	External Connectors for optical medium	YES	^b
Annex B	Type 1: Cable specifications and trunk and spur lengths for the 31,25 kbit/s voltage-mode MAU	NO	—
Annex C	Type 1: Optical passive stars	Partial	^b
Annex D	Type 1: Star topology	NO	^b
Annex E	Type 1: Alternate fibers	NO	^b
Next annexes	—	NO	—

Clause	Header	Presence	Constraints
^a	The selection is an alternate solution. All selected solutions are required to operate at a single common data rate.		
^b	The selection is an alternate solution, depending on the solution chosen from Clauses 11 or 15.		

5.4.2 Data-link layer

See 5.2.2.

5.4.3 Application layer

See 5.2.3.

6 Communication Profile Family 2 (CIP™⁵)

6.1 General overview

Communication Profile Family 2 defines several communication profiles based on IEC 61158-2 (protocol type 2), IEC 61158-3-2, IEC 61158-4-2, IEC 61158-5-2, and IEC 61158-6-2, and on other standards. These profiles all share for their upper layers the same communication system commonly known as the Common Industrial Protocol (CIP).

This part of IEC 61784 defines three communication profiles.

1) Profile 2/1 ControlNet™⁶

This profile contains a selection of AL, DLL and PhL services and protocol definitions from IEC 61158-2 type 2, IEC 61158-3-2, IEC 61158-4-2, IEC 61158-5-2, and IEC 61158-6-2. This profile uses the CIP common protocol and services in conjunction with the specific protocol type 2 DLL and PhL.

2) Profile 2/2 EtherNet/IP™⁷

This profile contains a selection of AL, DLL and PhL services and protocol definitions from IEC 61158-4-2, IEC 61158-5-2 and IEC 61158-6-2, and the TCP/UDP/IP/Ethernet protocol suite. This profile uses the CIP protocol and services in conjunction with the standard internet and Ethernet standards.

3) Profile 2/3 DeviceNet™⁸

This profile contains a selection of AL, DLL and PhL services and protocol definitions from IEC 61158-4-2, IEC 61158-5-2 and IEC 61158-6-2, and IEC 62026-3. This profile

⁵ CIP™ is a trade name of ODVA, Inc. This information is given for the convenience of users of this document and does not constitute an endorsement by IEC of the trademark holder or any of its products. Compliance to this profile does not require use of the trade name CIP™. Use of the trade name CIP™ requires permission of ODVA, Inc.

⁶ ControlNet™ is a trade name of ODVA, Inc. This information is given for the convenience of users of this document and does not constitute an endorsement by IEC of the trademark holder or any of its products. Compliance to this profile does not require use of the trade name ControlNet™. Use of the trade name ControlNet™ requires permission of ODVA, Inc.

⁷ EtherNet/IP™ is a trade name of ODVA, Inc. This information is given for the convenience of users of this document and does not constitute an endorsement by IEC of the trademark holder or any of its products. Compliance to this profile does not require use of the trade name EtherNet/IP™. Use of the trade name EtherNet/IP™ requires permission of ODVA, Inc.

⁸ DeviceNet™ is a trade name of ODVA, Inc. This information is given for the convenience of users of this document and does not constitute an endorsement by IEC of the trademark holder or any of its products. Compliance to this profile does not require use of the trade name DeviceNet™. Use of the trade name DeviceNet™ requires permission of ODVA, Inc.

uses the CIP protocol and services in conjunction with the CAN (ISO 11898) DLL and PhL, and additional elements specified in IEC 62026-3.

NOTE 1 See Clause A.2 for an overview of CIP and related networks communications concepts.

NOTE 2 Additional CPs are defined in the other parts of the IEC 61784 series.

It is strongly recommended that implementers of a specific profile comply with the appropriate conformance tests and validations provided by ODVA.

Table 101 gives a general overview of the corresponding profile sets.

Table 101 – CPF 2: overview of profile sets

Layer	CP 2/1 (ControlNet)	CP 2/2 (EtherNet/IP)	CP 2/3 (DeviceNet)
Application	IEC 61158-5-2, IEC 61158-6-2	IEC 61158-5-2, IEC 61158-6-2	IEC 61158-5-2, IEC 61158-6-2, IEC 62026-3
Transport	—	TCP/UDP (RFC 793/768) ^a	—
Network	—	IP (RFC 791) ^a	—
Data Link	IEC 61158-3-2, IEC 61158-4-2	ISO/IEC 8802-3, IEEE 802.3-2002	ISO 11898, IEC 62026-3
Physical	Type 2 of IEC 61158-2	ISO/IEC 8802-3, IEEE 802.3-2002 ^b	ISO 11898, IEC 62026-3
^a Additional RFC standards apply.			
^b Recommended connectors and cables are specified in IEC 61918 and IEC 61784-5-2.			

6.2 Profile 2/1 (ControlNet)

6.2.1 Physical layer

Table 102 specifies the PhL selection within IEC 61158-2.

Table 102 – CP 2/1: PhL selection

Clause	Header	Presence	Constraints
1	Scope	YES	—
2	Normative references	Partial	Relevant references only
3	Terms and definitions	—	—
3.1	Common terms and definitions	Partial	Relevant definitions only
3.2	Type 1: Terms and definitions	NO	—
3.3	Type 2: Terms and definitions	YES	—
3.4 – 3.10	—	NO	—
4	Symbols and abbreviations	—	—
4.1	Symbols	—	—
4.1.1	Type 1: Symbols	NO	—
4.1.2	Type 2: Symbols	YES	—
4.1.3 – 4.1.9	—	NO	—
4.2	Abbreviations	—	—
4.2.1	Type 1: Abbreviations	NO	—
4.2.2	Type 2: Abbreviations	YES	—
4.2.3 – 4.2.9	—	NO	—

Clause	Header	Presence	Constraints
5	DLL – PhL interface	—	—
5.1	General	YES	—
5.2	Type 1: Required services	NO	—
5.3	Type 2: Required services	YES	—
5.4 – 5.10	—	NO	—
6 – 8	—	NO	—
9	Medium dependent sublayer (MDS)	—	—
9.1	General	YES	—
9.2 – 9.3	—	NO	—
9.4	Type 2: MDS: Wire and optical media	YES	—
9.5 – 9.11	—	NO	—
10	MDS – MAU interface	—	—
10.1	General	YES	—
10.2 – 10.3	—	NO	—
10.4	Type 2: MDS – MAU interface: Wire and optical media	YES	Used MAU(s) are selected at device level
10.5 – 10.7	—	NO	—
11 – 17	—	NO	—
18	Type 2: Medium attachment unit: 5 Mbit/s, voltage-mode, coaxial wire medium	YES	Used MAU(s) are selected at device level
19	Type 2: Medium attachment unit: 5 Mbit/s, optical medium	YES	Used MAU(s) are selected at device level
20	Type 2: Medium attachment unit: Network access port (NAP)	YES	Used MAU(s) are selected at device level
Next clauses	—	NO	—
Annex A – E	—	NO	—
Annex F	(normative) Type 2: Connector specification	YES	—
Annex G	(normative) Type 2: Repeater machine sublayers (RM, RRM) and redundant PhLs	YES	—
Annex H	(informative) Type 2: Reference design examples	YES	—
Next annexes	—	NO	—

6.2.2 Data-link layer

6.2.2.1 DLL service selection

Table 103 specifies the DLL service selection within IEC 61158-3-2.

Table 103 – CP 2/1: DLL service selection

Clause	Header	Presence	Constraints
1	Scope	YES	—
2	Normative references	YES	—
3	Terms, definitions, symbols, abbreviations and conventions	YES	—
4	Connection-mode and connectionless-mode Data-link Service	YES	—
5	DL-management Services	YES	—

6.2.2.2 DLL protocol selection

Table 104 specifies the DLL protocol selection within IEC 61158-4-2.

Table 104 – CP 2/1: DLL protocol selection

Clause	Header	Presence	Constraints
1	Scope	YES	—
2	Normative references	YES	—
3	Terms, definitions, symbols, abbreviations and conventions	YES	—
4	Overview of the data-link protocol	YES	—
5	General structure and encoding of PhIDUs and DLPDUs and related elements of procedure	YES	—
6	Specific DLPDU structure, encoding and procedures	YES	—
7	Objects for station management	—	See Table 105
8	Other DLE elements of procedure	YES	—
9	Detailed specification of DL components	YES	—
10	Device Level Ring (DLR) protocol	NO	—
Annex A	(normative) – Indicators and switches	—	—
A.1	Purpose	YES	—
A.2	Indicators	—	—
A.2.1	General indicator requirements	YES	—
A.2.2	Common indicator requirements	YES	—
A.2.3	Fieldbus specific indicator requirements (1)	YES	—
A.2.4	Fieldbus specific indicator requirements (2)	NO	—
A.2.5	Fieldbus specific indicator requirements (3)	NO	—
A.3	Switches	—	—
A.3.1	Common switch requirements	YES	—
A.3.2	Fieldbus specific switch requirements (1)	YES	—
A.3.3	Fieldbus specific switch requirements (2)	NO	—
A.3.4	Fieldbus specific switch requirements (3)	NO	—

Table 105 specifies the management objects selection.

Table 105 – CP 2/1: DLL protocol selection of management objects

Clause	Header	Presence	Constraints
7	Objects for station management	—	—
7.1	General	Partial	Relevant objects only
7.2	ControlNet object	YES	—
7.3	Keeper object	YES	—
7.4	Scheduling object	YES	—
7.5	TCP/IP interface object	NO	—
7.6	Ethernet link object	NO	—
7.7	DeviceNet object	NO	—
7.8	Connection configuration object	YES	—
7.9	DLR object	NO	—
7.10	QoS object	NO	—
7.11	Port object	YES	—

6.2.3 Application layer

6.2.3.1 AL service selection

Table 106 specifies the AL service selection within IEC 61158-5-2.

Table 106 – CP 2/1: AL service selection

Clause	Header	Presence	Constraints
1	Scope	YES	—
2	Normative references	YES	—
3	Terms, definitions, symbols, abbreviations and conventions	YES	—
4	Common concepts	Partial	Differences are indicated in IEC 61158-5-2, 6.1
5	Data type ASE	Partial	Selection and restrictions are specified in IEC 61158-5-2, 6.1
6	Communication model specification	—	—
6.1	Concepts	YES	—
6.2	ASEs	—	—
6.2.1	Object management ASE	—	—
6.2.1.1	Overview	YES	—
6.2.1.2	FAL management model class specification	—	—
6.2.1.2.1	General formal model	YES	—
6.2.1.2.2	Identity formal model	YES	—
6.2.1.2.3	Assembly formal model	YES	—
6.2.1.2.4	Message router formal model	YES	—
6.2.1.2.5	Acknowledge handler formal model	YES	—
6.2.1.2.6	Time Sync formal model	YES	Optional
6.2.1.2.7	Parameter formal model	YES	—
6.2.1.3	FAL management model ASE service specification	YES	—
6.2.2	Connection manager ASE	YES	Single class in this ASE

Clause	Header	Presence	Constraints
6.2.3	Connection ASE	YES	Optional (internal or external)
6.3	ARs	YES	—
6.4	Summary of FAL classes	YES	—
6.5	Permitted FAL services by AR type	YES	—

6.2.3.2 AL protocol selection

Table 107 specifies the AL protocol selection within IEC 61158-6-2.

Table 107 – CP 2/1: AL protocol selection

Clause	Header	Presence	Constraints
1	Scope	YES	—
2	Normative references	YES	—
3	Terms, definitions, symbols, abbreviations and conventions	YES	—
4	Abstract syntax	—	—
4.1	FAL PDU abstract syntax	—	—
4.1.1 – 4.1.4	—	YES	—
4.1.5	CM_PDUs	Partial	Except 4.1.5.6.6
4.1.6 – 4.1.11	—	YES	—
4.2	Data abstract syntax specification	YES	—
4.3	Encapsulation abstract syntax	NO	—
5	Transfer syntax	YES	—
6	Structure of FAL protocol state machines	YES	—
7	AP-Context state machine	YES	—
8	FAL service protocol machine (FSPM)	YES	—
9	Application relationship protocol machines (ARPMs)	YES	—
10	DLL mapping protocol machine 1 (DMPM 1)	YES	—
11	DLL mapping protocol machine 2 (DMPM 2)	NO	—
12	DLL mapping protocol machine 3 (DMPM 3)	NO	—

6.3 Profile 2/2 (Ethernet/IP)

6.3.1 Physical layer

The physical layer of the Ethernet/IP profile is according to ISO/IEC 8802-3 and IEEE 802.3-2002.

Recommended connectors and cables are specified in IEC 61918 and IEC 61784-5-2.

NOTE 1 EtherNet/IP can be used with a number of media options (e.g. copper, fiber, fiber ring, wireless) in conjunction with the Ethernet lower layers.

NOTE 2 Additional information is provided in ODVA: The CIP Networks Library – Volume 2: EtherNet/IP™ Adaptation of CIP, Chapter 8: Physical Layer.

6.3.2 Data-link layer

6.3.2.1 DLL service selection

The Data-link layer of the Ethernet/IP profile is according to ISO/IEC 8802-3 and IEEE 802.3-2002.

6.3.2.2 DLL protocol selection

The Data-link layer of the Ethernet/IP profile is according to ISO/IEC 8802-3 and IEEE 802.3-2002.

Table 108 specifies the DLL protocol selection within IEC 61158-4-2.

Table 108 – CP 2/2: DLL protocol selection

Clause	Header	Presence	Constraints
1	Scope	YES	—
2	Normative references	YES	—
3	Terms, definitions, symbols, abbreviations and conventions	YES	—
4 – 5	—	NO	—
6	Specific DLPDU structure, encoding and procedures	—	—
6.1	Modeling language	YES	—
6.2 – 6.15	—	NO	—
7	Objects for station management	—	See Table 109
8 – 9	—	NO	—
10	Device Level Ring (DLR) protocol	YES	Optional
Annex A	(normative) – Indicators and switches	—	—
A.1	Purpose	YES	—
A.2	Indicators	—	—
A.2.1	General indicator requirements	YES	—
A.2.2	Common indicator requirements	YES	—
A.2.3	Fieldbus specific indicator requirements (1)	NO	—
A.2.4	Fieldbus specific indicator requirements (2)	YES	—
A.2.5	Fieldbus specific indicator requirements (3)	NO	—
A.3	Switches	—	—
A.3.1	Common switch requirements	YES	—
A.3.2	Fieldbus specific switch requirements (1)	NO	—
A.3.3	Fieldbus specific switch requirements (2)	YES	—
A.3.4	Fieldbus specific switch requirements (3)	NO	—

Table 109 specifies the management objects selection.

Table 109 – CP 2/2: DLL protocol selection of management objects

Clause	Header	Presence	Constraints
7	Objects for station management	—	—
7.1	General	Partial	Relevant objects and features only
7.2	ControlNet object	NO	—
7.3	Keeper object	NO	—
7.4	Scheduling object	NO	—
7.5	TCP/IP interface object	YES	—
7.6	Ethernet link object	YES	—
7.7	DeviceNet object	NO	—
7.8	Connection configuration object	YES	—
7.9	DLR object	YES	Optional (required if DLR protocol is implemented)
7.10	QoS object	YES	Optional
7.11	Port object	YES	—

6.3.3 Application layer

6.3.3.1 AL service selection

Table 110 specifies the AL service selection within IEC 61158-5-2.

Table 110 – CP 2/2: AL service selection

Clause	Header	Presence	Constraints
1	Scope	YES	—
2	Normative references	YES	—
3	Terms, definitions, symbols, abbreviations and conventions	YES	—
4	Common concepts	Partial	Differences are indicated in IEC 61158-5-2, 6.1
5	Data type ASE	Partial	Selection and restrictions are specified in IEC 61158-5-2, 6.1
6	Communication model specification	—	—
6.1	Concepts	YES	—
6.2	ASEs	—	—
6.2.1	Object management ASE	—	—
6.2.1.1	Overview	YES	—
6.2.1.2	FAL management model class specification	—	—
6.2.1.2.1	General formal model	YES	—
6.2.1.2.2	Identity formal model	YES	—
6.2.1.2.3	Assembly formal model	YES	—
6.2.1.2.4	Message router formal model	YES	—
6.2.1.2.5	Acknowledge handler formal model	YES	—
6.2.1.2.6	Time Sync formal model	YES	Optional
6.2.1.2.7	Parameter formal model	YES	—
6.2.1.3	FAL management model ASE service specification	YES	—

Clause	Header	Presence	Constraints
6.2.2	Connection manager ASE	YES	Single class in this ASE
6.2.3	Connection ASE	YES	Optional (internal or external)
6.3	ARs	—	—
6.3.1	Overview	YES	—
6.3.2	UCMM AR formal model	NO	—
6.3.3	Transport AR formal model	YES	—
6.3.4	AR ASE services	YES	—
6.4	Summary of FAL classes	YES	—
6.5	Permitted FAL services by AR type	YES	—

In addition AL services are mapped onto the TCP/UDP/IP protocol suite.

The corresponding minimum requirements for EtherNet/IP devices are as specified in RFC 1122, RFC 1123, RFC 1127 and subsequent documents that may supersede them. All EtherNet/IP devices shall as a minimum support requirements specified in RFC 768, RFC 791, RFC 792, RFC 793, RFC 826, RFC 894, RFC 1112 and RFC 2236.

If a feature or internet protocol is implemented by an EtherNet/IP device, this feature shall be implemented in accordance with the appropriate RFC documents, whether the feature or protocol is considered required or optional by this RFC document.

6.3.3.2 AL protocol selection

Table 111 specifies the AL protocol selection within IEC 61158-6-2.

Table 111 – CP 2/2: AL protocol selection

Clause	Header	Presence	Constraints
1	Scope	YES	—
2	Normative references	YES	—
3	Terms, definitions, symbols, abbreviations and conventions	YES	—
4	Abstract syntax	—	—
4.1	FAL PDU abstract syntax	—	—
4.1.1 – 4.1.2	—	YES	—
4.1.3	UCMM_PDUs	NO	—
4.1.4	Transport_Headers	YES	—
4.1.5	CM_PDUs	Partial	Except 4.1.5.6.6
4.1.6 – 4.1.11	—	YES	—
4.2	Data abstract syntax specification	YES	—
4.3	Encapsulation abstract syntax	YES	—
5	Transfer syntax	YES	—
6	Structure of FAL protocol state machines	YES	—
7	AP-Context state machine	YES	—
8	FAL service protocol machine (FSPM)	YES	—
9	Application relationship protocol machines (ARPMs)	—	—
9.1	General	YES	—

Clause	Header	Presence	Constraints
9.2	Connection-less ARPM (UCMM)	—	—
9.2.1	General	YES	—
9.2.2 – 9.2.6	—	NO	—
9.3	Connection-oriented ARPMS (transports)	YES	—
10	DLL mapping protocol machine 1 (DMPM 1)	NO	—
11	DLL mapping protocol machine 2 (DMPM 2)	YES	—
12	DLL mapping protocol machine 3 (DMPM 3)	NO	—

In addition, the AL protocol is mapped onto the TCP/UDP/IP protocol suite.

The corresponding minimum requirements for EtherNet/IP devices are as specified in RFC 1122, RFC 1123, RFC 1127 and subsequent documents that may supersede them. All EtherNet/IP devices shall as a minimum support requirements specified in RFC 768, RFC 791, RFC 792, RFC 793, RFC 826, RFC 894, RFC 1112 and RFC 2236.

If a feature or internet protocol is implemented by an EtherNet/IP device, this feature shall be implemented in accordance with the appropriate RFC documents, whether the feature or protocol is considered required or optional by this RFC document.

6.4 Profile 2/3 (DeviceNet)

6.4.1 Physical layer

The physical layer of the DeviceNet profile is specified in IEC 62026-3 and ISO 11898.

6.4.2 Data-link layer

6.4.2.1 DLL service selection

The Data-link layer of the DeviceNet profile is specified in IEC 62026-3 and ISO 11898.

6.4.2.2 DLL protocol selection

The Data-link layer of the DeviceNet profile is specified in IEC 62026-3 and ISO 11898.

Table 112 specifies the DLL protocol selection within IEC 61158-4-2.

Table 112 – CP 2/3: DLL protocol selection

Clause	Header	Presence	Constraints
1	Scope	YES	—
2	Normative references	YES	—
3	Terms, definitions, symbols, abbreviations and conventions	YES	—
4 – 5	—	NO	—
6	Specific DLPDU structure, encoding and procedures	—	—
6.1	Modeling language	YES	—
6.2 – 6.15	—	NO	—
7	Objects for station management	—	See Table 113
8 – 9	—	NO	—
10	Device Level Ring (DLR) protocol	NO	—
Annex A	(normative) – Indicators and switches	—	—
A.1	Purpose	YES	—
A.2	Indicators	—	—
A.2.1	General indicator requirements	YES	—
A.2.2	Common indicator requirements	YES	—
A.2.3	Fieldbus specific indicator requirements (1)	NO	—
A.2.4	Fieldbus specific indicator requirements (2)	NO	—
A.2.5	Fieldbus specific indicator requirements (3)	YES	—
A.3	Switches	—	—
A.3.1	Common switch requirements	YES	—
A.3.2	Fieldbus specific switch requirements (1)	NO	—
A.3.3	Fieldbus specific switch requirements (2)	NO	—
A.3.4	Fieldbus specific switch requirements (3)	YES	—

Table 113 specifies the management objects selection.

Table 113 – CP 2/3: DLL protocol selection of management objects

Clause	Header	Presence	Constraints
7	Objects for station management	—	—
7.1	General	Partial	Relevant objects and features only
7.2	ControlNet object	NO	—
7.3	Keeper object	NO	—
7.4	Scheduling object	NO	—
7.5	TCP/IP interface object	NO	—
7.6	Ethernet link object	NO	—
7.7	DeviceNet object	YES	—
7.8	Connection configuration object	YES	—
7.9	DLR object	NO	—
7.10	QoS object	NO	—
7.11	Port object	YES	—

6.4.3 Application layer

6.4.3.1 AL service selection

Table 114 specifies the AL service selection within IEC 61158-5-2.

Table 114 – CP 2/3: AL service selection

Clause	Header	Presence	Constraints
1	Scope	YES	—
2	Normative references	YES	—
3	Terms, definitions, symbols, abbreviations and conventions	YES	—
4	Common concepts	Partial	Differences are indicated in IEC 61158-5-2, 6.1
5	Data type ASE	Partial	Selection and restrictions are specified in IEC 61158-5-2, 6.1
6	Communication model specification	—	—
6.1	Concepts	YES	—
6.2	ASEs	—	—
6.2.1	Object management ASE	—	—
6.2.1.1	Overview	YES	—
6.2.1.2	FAL management model class specification	—	—
6.2.1.2.1	General formal model	YES	—
6.2.1.2.2	Identity formal model	YES	—
6.2.1.2.3	Assembly formal model	YES	—
6.2.1.2.4	Message router formal model	YES	—
6.2.1.2.5	Acknowledge handler formal model	YES	—
6.2.1.2.6	Time Sync formal model	YES	Optional
6.2.1.2.7	Parameter formal model	YES	—
6.2.1.3	FAL management model ASE service specification	YES	—
6.2.2	Connection manager ASE	NO	—
6.2.3	Connection ASE	YES	Single class in this ASE
6.3	ARs	—	—
6.3.1	Overview	YES	—
6.3.2	UCMM AR formal model	NO	—
6.3.3	Transport AR formal model	Partial	Transport ARs 0, 2 and 3 only
6.3.4	AR ASE services	YES	—
6.4	Summary of FAL classes	YES	—
6.5	Permitted FAL services by AR type	YES	—

In addition AL services are mapped onto the CAN (ISO 11898) protocol suite, as specified in IEC 62026-3.

6.4.3.2 AL protocol selection

Table 115 specifies the AL protocol selection within IEC 61158-6-2.

Table 115 – CP 2/3: AL protocol selection

Clause	Header	Presence	Constraints
1	Scope	YES	—
2	Normative references	YES	—
3	Terms, definitions, symbols, abbreviations and conventions	YES	—
4	Abstract syntax	—	—
4.1	FAL PDU abstract syntax	—	—
4.1.1 – 4.1.2	—	YES	—
4.1.3	UCMM_PDUs	NO	—
4.1.4 – 4.1.11	—	YES	—
4.2	Data abstract syntax specification	YES	—
4.3	Encapsulation abstract syntax	NO	—
5	Transfer syntax	YES	—
6	Structure of FAL protocol state machines	YES	—
7	AP-Context state machine	YES	—
8	FAL service protocol machine (FSPM)	YES	—
9	Application relationship protocol machines (ARPMs)	—	—
9.1	General	YES	—
9.2	Connection-less ARPM (UCMM)	—	—
9.2.1	General	YES	—
9.2.2 – 9.2.6	—	NO	—
9.3	Connection-oriented ARPMs (transports)	Partial	Transport classes 0, 2 and 3 only
10	DLL mapping protocol machine 1 (DMPM 1)	NO	—
11	DLL mapping protocol machine 2 (DMPM 2)	NO	—
12	DLL mapping protocol machine 3 (DMPM 3)	YES	—

In addition, the AL protocol is mapped onto the CAN (ISO 11898) protocol suite, as specified in IEC 62026-3.

7 Communication Profile Family 3 (PROFIBUS & PROFINET⁹)

7.1 General overview

Communication Profile Family 3 (CPF 3) defines communication profiles using Type 3 and Type 10 of IEC 61158 series, which corresponds to parts of the communication systems commonly known as PROFIBUS and PROFINET. CP 3/1 and CP 3/2 are specified in IEC 61784-1. CP 3/4, CP3/5, and CP 3/6 are RTE specific PROFINET profiles and specified in IEC 61784-2.

Table 116 give an overview of the specified profile sets.

⁹ PROFIBUS and PROFINET are trademarks of PROFIBUS Nutzerorganisation e.V. (PNO). PNO is a non-profit trade organization to support the fieldbus PROFIBUS. This information is given for the convenience of users of this document and does not constitute an endorsement by IEC of the trademark holder or any of its products. Compliance to this profile does not require use of the registered trademark. Use of the trademark PROFIBUS and PROFINET requires permission of the trade name holder.

Table 116 – CPF 3: overview of profile sets

Layer	Profile 3/1				Profile 3/2
Application	IEC 61158-5-3, IEC 61158-6-3				
Data-link	IEC 61158-3-3, IEC 61158-4-3 Asynchronous transmission				IEC 61158-3-3, IEC 61158-4-3 Synchronous transmission
Physical	0 ^a	2 ^a	3 ^a	4 ^a	1 ^a
^a These numbers are the CP identifier used within Communication Feature List (GSD) in keyword "Physical Interface". Coding: 0: RS 485 (ANSI TIA/EIA RS-485-A); optional RS 485-IS 1: Manchester coded and bus powered (MBP); optional IS (MBP-IS) and lower power (MBP-LP) 2: Plastic fiber; 3: Glass multi mode fiber or Glass single mode fiber; 4: PCF fiber. NOTE PROFIBUS uses Profile 3/1 and 3/2. PROFIBUS DP is the name of AL protocol and service part, which is identical for CP 3/1 and CP 3/2 and uses the Type 3 DL parts.					

NOTE 1 See Clause A.3 for an overview of PROFIBUS communications concepts and definition of DP-V0, DP-V1 and Options.

An implementation profile like temperature transmitter or master device shall select from CPF 3 these behaviors that are needed for a certain device type. The manufacturer of a device shall describe the selection for CP 3/1 and CP 3/2 by writing a Communication Feature List (GSD) according ISO 15745-3, 6.2. The GSD is necessary to specify an implementation profile. CP 3/3 specifies an Ethernet based communication system. The manufacturer of a device shall describe the selection for CP 3/3 by writing a Communication Feature List (GSD) according ISO 15745-4, Amendment 1 (2006).

It is recommended to perform a conformance test, which is not normative but specified within the consortium PROFIBUS International. Each CP 3/1 and CP 3/2 conformant device shall have a type specific GSD, which is part of the conformance test.

The CPF3 specifies in this part of IEC 61784 two distinct profiles:

- a) Profile 3/1
Profile 3/1 is a subset of IEC 61158 Type 3 services and protocols and uses the as physical layer (PhL) four different media, see Table 116. A Communication Profile (CP) identifier identifies these.
- b) Profile 3/2
Profile 3/2 is a subset of IEC 61158 Type 3 services and protocols and uses the Manchester coded bus powered (MBP) synchronous transmission of PhL specified in Type 3. Based on different transmission technologies for PROFIBUS DP the DLL contains different interfaces to the PhL. That causes different communication profiles for PROFIBUS DP.
The MBP non-IS PhL is the basis for the extended specification for IS (MBP-IS) and low power (MBP-LP) capability. MBP-LP supports IS. Slave devices with a MAU supporting MBP-LP are also usable in systems that require MBP-IS or MBP. Slave devices with a MAU supporting MBP-IS are also usable in a system that requires MBP. Figure 3 shows this hierarchy.

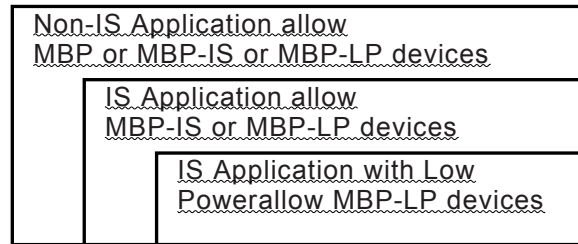

Figure 3 – CP 3/2 Slave devices usable in applications

NOTE 2 Additional CPs are defined in the other parts of IEC 61784.

7.2 Profile 3/1 (PROFIBUS DP)

7.2.1 Physical layer

7.2.1.1 PhL selection

Table 117 specifies the selection of IEC 61158-2 for devices of all types of this profile. Subclause 7.2.1.2 specifies additional considerations.

Table 117 – CP 3/1: PhL selection

Clause	Header	Presence	Constraints
1	Scope	YES	—
2	Normative references	Partial	Relevant references only
3	Terms and definitions	Partial	See Table 118
4	Symbols and abbreviations	Partial	See Table 119
5	DLL – PhL interface	—	—
5.1	General	YES	—
5.2 – 5.3	—	NO	—
5.4	Type 3: Required services	—	—
5.4.1	Synchronous transmission	NO	—
5.4.2	Asynchronous transmission	YES	—
5.5 – 5.7	—	NO	—
6	Systems management – PhL interface	—	—
6.1	General	YES	—
6.2	Type 1: Systems management – PhL interface	NO	—
6.3	Type 3: Systems management – PhL interface	—	—
6.3.1	Synchronous transmission	NO	—
6.3.2	Asynchronous transmission	YES	—
6.4 – 6.8	—	NO	—
7	DCE Independent sublayer (DIS)	—	—
7.1	General	YES	—
7.2	Type 1: DIS	NO	—
7.3	Type 3: DIS	—	—
7.3.1	Synchronous transmission	NO	—
7.3.2	Asynchronous transmission	YES	—
7.4 – 7.6	—	NO	—

Clause	Header	Presence	Constraints
8	DTE – DCE interface and MIS-specific functions	—	—
8.1	General	YES	—
8.2	Type 1: DTE – DCE interface	NO	—
8.3	Type 3: DTE – DCE interface	—	—
8.3.1	Synchronous transmission	NO	—
8.3.2	Asynchronous transmission	YES	—
8.4 – 8.5	—	NO	—
9	Medium dependent sublayer (MDS)	—	—
9.1	General	YES	—
9.2 – 9.4	—	NO	—
9.5	Type 3: MDS: Wire and optical media	—	—
9.5.1	Synchronous Transmission	NO	—
9.5.2	Asynchronous Transmission	YES	—
9.6 – 9.11	—	NO	—
10	MDS – MAU interface	—	—
10.1	General	YES	—
10.2 – 10.4	—	NO	—
10.5	Type 3: MDS – MAU interface: Wire and optical media	—	—
10.5.1	Synchronous Transmission	NO	—
10.5.2	Asynchronous Transmission	YES	—
10.6 – 10.8	—	NO	—
11 – 21	—	NO	—
22	Type 3: Medium Attachment Unit: Asynchronous Transmission, wire medium	—	—
22.1	Medium Attachment Unit for non intrinsic Safety	YES	For RS 485
22.2	Medium Attachment Unit for intrinsic Safety	YES	For RS 485-IS
23	Type 3: Medium Attachment Unit: Asynchronous Transmission, optical medium	YES	For Plastic, Glass and PCF fiber
Next clauses	—	NO	—
Annex A – H	—	NO	—
Annex I	(normative) Type 3: Connector specification	—	—
I.1	Connector for synchronous transmission	NO	—
I.2	Connector for asynchronous transmission	YES	For RS 485
I.3	Connector for fiber optic cable	YES	For Plastic, Glass and PCF fiber
Annex J	(normative) Type 3: Redundancy of PhL and medium	YES	Redundancy is optional
Annex K	(normative) Type 3: Optical network topology	YES	For Plastic, Glass and PCF fiber
Annex L	Reference design examples for asynchronous transmission, wire medium, intrinsically safe	YES	For RS 485-IS
Next annexes	—	NO	—

Table 118 – CP 3/1: PhL selection of Clause 3

Clause	Header	Presence	Constraints
3.1	Common terms and definitions	Partial	See 3.4
3.2 – 3.3	—	NO	—
3.4	Type 3: Terms and definitions	Partial	Relevant terms and definitions only
3.5 – 3.10	—	NO	—

Table 119 – CP 3/1: PhL selection of Clause 4

Clause	Header	Presence	Constraints
4.1	Symbols	YES	—
4.1.1 – 4.1.2	—	NO	—
4.1.3	Type 3: Symbols	YES	—
4.1.4 – 4.1.9	—	NO	—
4.2	Abbreviations	—	—
4.2.1 – 4.2.2	—	NO	—
4.2.3	Type 3: Abbreviations	Partial	Relevant abbreviations only
4.2.4 – 4.2.9	—	NO	—

7.2.1.2 Electrical safety

Devices shall comply with the legal requirements of that country where they are deployed (for example, as indicated by the CE mark). The measures for protection against electrical shocks (i.e. electrical safety) within industrial applications shall be based on the IEC 61010 series or IEC 61131-2 depending on device type specified therein.”

7.2.2 Data-link layer

7.2.2.1 DLL service selection

7.2.2.1.1 General selection

Table 120 specifies the selection of the Data-link services within IEC 61158-3-3.

Table 120 – CP 3/1: General DLL service selection

Clause	Header	Presence	Constraints
1	Scope	YES	—
2	Normative references	Partial	Relevant references only
3	Terms, definitions, symbols, abbreviations and conventions	—	—
3.1	Reference model terms and definitions	Partial	Used when applicable
3.2	Service convention terms and definitions	Partial	Used when applicable
3.3	Common data-link service terms and definitions	Partial	Used when applicable
3.4	Additional Type 3 data-link specific definitions	YES	—
3.5	Common symbols and abbreviations	Partial	Relevant symbols and abbreviations only
3.6	Additional Type 3 symbols and abbreviations	YES	—
3.7	Common conventions	Partial	Used when applicable

Clause	Header	Presence	Constraints
3.8	Additional Type 3 conventions	YES	—
4	Connectionless-mode Data-link Service	Partial	See 7.2.2.1.2 to 7.2.2.1.4
5	DL-management service	Partial	See 7.2.2.1.2 to 7.2.2.1.4

7.2.2.1.2 Selection for DP-master (class 1)

7.2.2.1.2.1 DP-V0 master (class 1)

Table 121 specifies CP 3/1 DL services, which are part of DP-master (class 1) and using features named DP-V0.

Table 121 – CP 3/1: DLL service selection for DP-V0 master (class 1)

Clause	Header	Presence	Constraints
4.1	General	YES	—
4.2	Model of the connectionless-mode Data-link Service	YES	
4.3	Sequence of primitives	Partial	—
4.4	Detailed description of DL services	—	—
4.4.1	Send Data with Acknowledge (SDA)	NO	—
4.4.2	Send Data with No Acknowledge (SDN)	—	—
4.4.2.1	Function	YES	
4.4.2.2	Types of primitives and parameters	YES	—
4.4.2.3	SDN request primitive	YES	—
4.4.2.4	SDN indication primitive	YES	Option
4.4.2.5	SDN confirm primitive	YES	—
4.4.3	Send and Request Data with Reply (SRD)	—	—
4.4.3.1	Function	YES	—
4.4.3.2	Types of primitives and parameters of SRD data-reply	YES	—
4.4.3.3	SRD data-reply request primitive	YES	—
4.4.3.4	SRD data-reply indication primitive	YES	—
4.4.3.5	SRD data-reply confirm primitive	YES	—
4.4.3.6	Types of primitives and parameters of SRD reply-update	YES	—
4.4.3.7	SRD reply-update request primitive	YES	—
4.4.3.8	SRD reply-update confirm primitive	YES	—
4.4.4	Send and Request Data with Multicast reply (MSRD)	NO	—
4.4.5	Clock Synchronisation (CS)	NO	—

Table 122 specifies CP 3/1 DLM services, which are part of DP-master (class 1) and using features named DP-V0.

Table 122 – CP 3/1: DLM service selection for DP-V0 master (class 1)

Clause	Header	Presence	Constraints
5.1	General	YES	—
5.2	Facilities of the DLMS	YES	—
5.3	Services of the DL-management	Partial	—
5.4	Overview of interactions	Partial	—
5.5	Detailed specification of services and interactions	—	—
5.5.1	Reset	YES	—
5.5.2	Set Value	YES	See DLE-variables in IEC 61158-3-3, Table 22 and 23
5.5.3	Get Value	YES	Option Only subset of DLE-variables according to IEC 61158-3-3
5.5.4	Event	YES	Only subset of Event/Fault according to IEC 61158-3-3
5.5.5	Ident	YES	Option
5.5.6	DLSAP Status	YES	Option
5.5.7	DLSAP Activate	YES	—
5.5.8	DLSAP Activate Responder	YES	Option
5.5.9	DLSAP Activate Subscriber	NO	—
5.5.10	DLSAP Deactivate	YES	—

7.2.2.1.2.2 DP-V1 master (class 1)

Table 123 specifies CP 3/1 DL services, which are part of DP-master (class 1) and using features named DP-V1 and Options.

Table 123 – CP 3/1: DLL service selection for DP-V1 master (class 1)

Clause	Header	Presence	Constraints
4.1	General	YES	—
4.2	Model of the connectionless-mode Data-link Service	YES	—
4.3	Sequence of primitives	YES	Used when applicable
4.4	Detailed description of DL services	—	—
4.4.1	Send Data with Acknowledge (SDA)	NO	—
4.4.2	Send Data with No Acknowledge (SDN)	—	—
4.4.2.1	Function	YES	—
4.4.2.2	Types of primitives and parameters	YES	Used when applicable
4.4.2.3	SDN request primitive	YES	—
4.4.2.4	SDN indication primitive	YES	Option
4.4.2.5	SDN confirm primitive	YES	—
4.4.3	Send and Request Data with Reply (SRD)	—	—
4.4.3.1	Function	YES	—
4.4.3.2	Types of primitives and parameters of SRD data-reply	YES	—
4.4.3.3	SRD data-reply request primitive	YES	—
4.4.3.4	SRD data-reply indication primitive	YES	Option
4.4.3.5	SRD data-reply confirm primitive	YES	—
4.4.3.6	Types of primitives and parameters of SRD reply-update	YES	Option
4.4.3.7	SRD reply-update request primitive	YES	Option
4.4.3.8	SRD reply-update confirm primitive	YES	Option
4.4.4	Send and Request Data with Multicast reply (MSRD)	—	—
4.4.4.1	Function	YES	Option
4.4.4.2	Types of primitives and parameters of MSRD MCT-data-reply	YES	Option
4.4.4.3	MSRD MCT-DATA-REPLY request primitive	YES	Option
4.4.4.4	MSRD MCT-data-reply indication primitive	NO	—
4.4.4.5	MSRD MCT-data-reply confirm primitive	YES	Option
4.4.4.6	Type of primitive and parameters of MSRD DXM data reply	YES	Option
4.4.4.7	MSRD DXM data reply indication primitive	YES	Option
4.4.4.8	SRD reply-update request primitive	NO	—
4.4.4.9	SRD reply-update confirm primitive	NO	—
4.4.5	Clock Synchronisation (CS)	—	—
4.4.5.1	Function	YES	Option
4.4.5.2	Types of primitives and parameters of the CS time event	YES	Option
4.4.5.3	CS time event request primitive	YES	Option
4.4.5.4	CS time event confirm primitive	YES	Option
4.4.5.5	Types of primitives and parameters of the CS clock value	YES	Option
4.4.5.6	CS clock value request primitive	YES	Option
4.4.5.7	CS clock value indication primitive	YES	Option
4.4.5.8	CS clock value confirm primitive	YES	Option

Table 124 specifies CP 3/1 DLM services, which are part of DP-master (class 1) and using features named DP-V1 and Options.

Table 124 – CP 3/1: DLM service selection for DP-V1 master (class 1)

Clause	Header	Presence	Constraints
5.1	General	YES	—
5.2	Facilities of the DLMS	YES	—
5.3	Services of the DL-management	YES	Used when applicable
5.4	Overview of interactions	YES	Used when applicable
5.5	Detailed specification of services and interactions	—	—
5.5.1	Reset	YES	—
5.5.2	Set Value	YES	—
5.5.3	Get Value	YES	Option
5.5.4	Event	YES	—
5.5.5	Ident	YES	Option
5.5.6	DLSAP Status	YES	Option
5.5.7	DLSAP Activate	YES	—
5.5.8	DLSAP Activate Responder	YES	Option
5.5.9	DLSAP Activate Subscriber	YES	—
5.5.10	DLSAP Deactivate	YES	—

7.2.2.1.3 Selection for DP-master (Class 2)

7.2.2.1.3.1 DP-V0 master (Class 2)

Table 125 specifies CP 3/1 DL services, which are part of DP-master (class 2) and using features named DP-V0.

Table 125 – CP 3/1: DLL service selection for DP-V0 master (class 2)

Clause	Header	Presence	Constraints
4.1	General	YES	—
4.2	Model of the connectionless-mode Data-link Service	YES	—
4.3	Sequence of primitives	YES	Used when applicable
4.4	Detailed description of DL services	—	—
4.4.1	Send Data with Acknowledge (SDA)	NO	—
4.4.2	Send Data with No Acknowledge (SDN)	—	—
4.4.2.1	Function	YES	—
4.4.2.2	Types of primitives and parameters	YES	Used when applicable
4.4.2.3	SDN request primitive	YES	Option
4.4.2.4	SDN indication primitive	NO	—
4.4.2.5	SDN confirm primitive	YES	Option
4.4.3	Send and Request Data with Reply (SRD)	—	—
4.4.3.1	Function	YES	—
4.4.3.2	Types of primitives and parameters of SRD data-reply	YES	Used when applicable
4.4.3.3	SRD data-reply request primitive	YES	—
4.4.3.4	SRD data-reply indication primitive	NO	—
4.4.3.5	SRD data-reply confirm primitive	YES	—

Clause	Header	Presence	Constraints
4.4.3.6	Types of primitives and parameters of SRD reply-update	NO	—
4.4.3.7	SRD reply-update request primitive	NO	—
4.4.3.8	SRD reply-update confirm primitive	NO	—
4.4.4	Send and Request Data with Multicast reply (MSRD)	NO	—
4.4.5	Clock Synchronization (CS)	NO	—

The CP 3/1 DLM services, which are part of DP-master (class 2) and using features named DP-V0, are the same as specified for DP-V0-master (class 1) in Table 122.

7.2.2.1.3.2 DP-V1 master (Class 2)

Table 126 specifies CP 3/1 DL services, which are part of DP-master (class 2) and using features named DP-V0.

Table 126 – CP 3/1: DLL service selection for DP-V1 master (class 2)

Clause	Header	Presence	Constraints
4.1	General	YES	—
4.2	Model of the connectionless-mode Data-link Service	YES	—
4.3	Sequence of primitives	YES	Used when applicable
4.4	Detailed description of DL services	—	—
4.4.1	Send Data with Acknowledge (SDA)	NO	—
4.4.2	Send Data with No Acknowledge (SDN)	—	—
4.4.2.1	Function	YES	—
4.4.2.2	Types of primitives and parameters	YES	Used when applicable
4.4.2.3	SDN request primitive	YES	Option
4.4.2.4	SDN indication primitive	NO	—
4.4.2.5	SDN confirm primitive	YES	Option
4.4.3	Send and Request Data with Reply (SRD)	—	—
4.4.3.1	Function	YES	—
4.4.3.2	Types of primitives and parameters of SRD data-reply	YES	Used when applicable
4.4.3.3	SRD data-reply request primitive	YES	—
4.4.3.4	SRD data-reply indication primitive	NO	—
4.4.3.5	SRD data-reply confirm primitive	YES	—
4.4.3.6	Types of primitives and parameters of SRD reply-update	NO	—
4.4.3.7	SRD reply-update request primitive	NO	—
4.4.3.8	SRD reply-update confirm primitive	NO	—
4.4.4	Send and Request Data with Multicast reply (MSRD)	—	—
4.4.4.1	Function	YES	Option
4.4.4.2	Types of primitives and parameters of MSRD MCT-data-reply	YES	Option
4.4.4.3	MSRD MCT-DATA-REPLY request primitive	NO	—
4.4.4.4	MSRD MCT-data-reply indication primitive	NO	—

Clause	Header	Presence	Constraints
4.4.4.5	MSRD MCT-data-reply confirm primitive	NO	—
4.4.4.6	Type of primitive and parameters of MSRD DXM data reply	YES	Option
4.4.4.7	MSRD DXM data reply indication primitive	YES	Option
4.4.4.8	SRD reply-update request primitive	NO	—
4.4.4.9	SRD reply-update confirm primitive	NO	—
4.4.5	Clock Synchronization (CS)	—	—
4.4.5.1	Function	YES	Option
4.4.5.2	Types of primitives and parameters of the CS time event	YES	Option
4.4.5.3	CS time event request primitive	YES	Option
4.4.5.4	CS time event confirm primitive	YES	Option
4.4.5.5	Types of primitives and parameters of the CS clock value	YES	Option
4.4.5.6	CS clock value request primitive	YES	Option
4.4.5.7	CS clock value indication primitive	YES	Option
4.4.5.8	CS clock value confirm primitive	YES	Option

The CP 3/1 DLM services, which are part of DP-master (class 2) and using features named DP-V1 and Options, are the same as specified for DP-V1-master (class 1) in Table 124.

7.2.2.1.4 Selection for DP-slave

7.2.2.1.4.1 DP-V0 slave

Table 127 specifies CP 3/1 DL services, which are part of DP-slave and using features named DP-V0.

Table 127 – CP 3/1: DLL service selection for DP-V0 slave

Clause	Header	Presence	Constraints
4.1	General	YES	—
4.2	Model of the connectionless-mode Data-link Service	YES	—
4.3	Sequence of primitives	YES	Used when applicable
4.4	Detailed description of DL services	—	—
4.4.1	Send Data with Acknowledge (SDA)	NO	—
4.4.2	Send Data with No Acknowledge (SDN)	—	—
4.4.2.1	Function	YES	—
4.4.2.2	Types of primitives and parameters	YES	Used when applicable
4.4.2.3	SDN request primitive	NO	—
4.4.2.4	SDN indication primitive	YES	—
4.4.2.5	SDN confirm primitive	NO	—
4.4.3	Send and Request Data with Reply (SRD)	—	—
4.4.3.1	Function	YES	—
4.4.3.2	Types of primitives and parameters of SRD data-reply	YES	Used when applicable
4.4.3.3	SRD data-reply request primitive	NO	—
4.4.3.4	SRD data-reply indication primitive	YES	—
4.4.3.5	SRD data-reply confirm primitive	NO	—
4.4.3.6	Types of primitives and parameters of SRD reply-update	YES	—
4.4.3.7	SRD reply-update request primitive	YES	—
4.4.3.8	SRD reply-update confirm primitive	YES	—
4.4.4	Send and Request Data with Multicast reply (MSRD)	NO	—
4.4.5	Clock Synchronization (CS)	NO	—

Table 128 specifies CP 3/1 DLM services, which are part of DP-slave and using features named DP-V0.

Table 128 – CP 3/1: DLM service selection for DP-V0 slave

Clause	Header	Presence	Constraints
5.1	General	YES	—
5.2	Facilities of the DLMS	YES	—
5.3	Services of the DL-management	YES	Used when applicable
5.4	Overview of interactions	YES	Used when applicable
5.5	Detailed specification of services and interactions	—	—
5.5.1	Reset	YES	—
5.5.2	Set Value	YES	Only subset of DLE-variables according to IEC 61158-3-3
5.5.3	Get Value	YES	Option Only subset of DLE-variables according to IEC 61158-3-3
5.5.4	Event	YES	Only subset of Event/Fault according to IEC 61158-3-3
5.5.5	Ident	YES	Option Only local
5.5.6	DLSAP Status	YES	Option Only local
5.5.7	DLSAP Activate	YES	Restrictions to parameter values according to IEC 61158-3-3
5.5.8	DLSAP Activate Responder	YES	Restrictions to parameter values according to IEC 61158-3-3
5.5.9	DLSAP Activate Subscriber	NO	—
5.5.10	DLSAP Deactivate	YES	—

7.2.2.1.4.2 DP-V1 slave

Table 129 specifies CP 3/1 DL services, which are part of DP-slave and using features named DP-V1 and Options.

Table 129 – CP 3/1: DLL service selection for DP-V1 slave

Clause	Header	Presence	Constraints
4.1	General	YES	—
4.2	Model of the connectionless-mode Data-link Service	YES	—
4.3	Sequence of primitives	YES	Used when applicable
4.4	Detailed description of DL services	—	—
4.4.1	Send Data with Acknowledge (SDA)	NO	—
4.4.2	Send Data with No Acknowledge (SDN)	—	—
4.4.2.1	Function	YES	—
4.4.2.2	Types of primitives and parameters	YES	Used when applicable
4.4.2.3	SDN request primitive	NO	—
4.4.2.4	SDN indication primitive	YES	—
4.4.2.5	SDN confirm primitive	NO	—
4.4.3	Send and Request Data with Reply (SRD)	YES	—
4.4.3.1	Function	YES	—
4.4.3.2	Types of primitives and parameters of SRD data-reply	YES	Used when applicable
4.4.3.3	SRD data-reply request primitive	NO	—
4.4.3.4	SRD data-reply indication primitive	YES	—
4.4.3.5	SRD data-reply confirm primitive	NO	—
4.4.3.6	Types of primitives and parameters of SRD reply-update	YES	—
4.4.3.7	SRD reply-update request primitive	YES	—
4.4.3.8	SRD reply-update confirm primitive	YES	—
4.4.4	Send and Request Data with Multicast reply (MSRD)	—	—
4.4.4.1	Function	YES	Option
4.4.4.2	Types of primitives and parameters of MSRD MCT-data-reply	YES	Option
4.4.4.3	MSRD MCT-DATA-REPLY request primitive	NO	—
4.4.4.4	MSRD MCT-data-reply indication primitive	YES	Option
4.4.4.5	MSRD MCT-data-reply confirm primitive	NO	—
4.4.4.6	Type of primitive and parameters of MSRD DXM data reply	YES	Option
4.4.4.7	MSRD DXM data reply indication primitive	YES	Option
4.4.4.8	SRD reply-update request primitive	YES	Option
4.4.4.9	SRD reply-update confirm primitive	YES	Option
4.4.5	Clock Synchronization (CS)	—	—
4.4.5.1	Function	YES	Option
4.4.5.2	Types of primitives and parameters of the CS time event	NO	—
4.4.5.3	CS time event request primitive	NO	—
4.4.5.4	CS time event confirm primitive	NO	—
4.4.5.5	Types of primitives and parameters of the CS clock value	YES	Option
4.4.5.6	CS clock value request primitive	NO	—
4.4.5.7	CS clock value indication primitive	YES	Option
4.4.5.8	CS clock value confirm primitive	NO	—

Table 130 specifies CP 3/1 DLM services, which are part of DP-slave and using features named DP-V1 and Options.

Table 130 – CP 3/1: DLM service selection for DP-V1 slave

Clause	Header	Presence	Constraints
5.1	General	YES	—
5.2	Facilities of the DLMS	YES	—
5.3	Services of the DL-management	YES	Used when applicable
5.4	Overview of interactions	YES	Used when applicable
5.5	Detailed specification of services and interactions	—	—
5.5.1	Reset	YES	—
5.5.2	Set Value	YES	Only subset of DLE-variables according to IEC 61158-3-3
5.5.3	Get Value	YES	Option Only subset of DLE-variables according to IEC 61158-3-3
5.5.4	Event	YES	Only subset of Event/Fault according to IEC 61158-3-3
5.5.5	Ident	YES	Option Only local
5.5.6	DLSAP Status	YES	Option Only local
5.5.7	DLSAP Activate	YES	Restrictions to parameter values according to IEC 61158-3-3
5.5.8	DLSAP Activate Responder	YES	—
5.5.9	DLSAP Activate Subscriber	YES	Option
5.5.10	DLSAP Deactivate	YES	—

7.2.2.2 DLL protocol selection

7.2.2.2.1 General selection

Table 131 specifies the selection of the data-link protocol within IEC 61158-4-3.

Table 131 – CP 3/1: General DLL protocol selection

Clause	Header	Presence	Constraints
1	Scope	YES	—
2	Normative references	Partial	Relevant references only
3	Terms, definitions, symbols and abbreviations	—	—
3.1	Reference model terms and definitions	Partial	Used when applicable
3.2	Service convention terms and definitions	Partial	Used when applicable
3.3	Common terms and definitions	Partial	Used when applicable
3.4	Additional Type 3 definitions	YES	—
3.5	Common symbols and abbreviations	Partial	Relevant symbols and abbreviations only
3.6	Type 3 symbols and abbreviations	YES	—
4	Common DL protocol elements	YES	—
5	Overview of the DL-protocol	Partial	See Table 132 and 7.2.2.2.2 to 7.2.2.2.4
6	General structure and encoding of DLPDUs, and related elements of procedure	Partial	See Table 133 and 7.2.2.2.2 to 7.2.2.2.4
7	DLPDU-specific structure, encoding and elements of procedure	Partial	See Table 134 and 7.2.2.2.2 to 7.2.2.2.4
8	Other DLE elements of procedure	Partial	See 7.2.2.2.2 to 7.2.2.2.4
Annex A	DL-protocol state machines	YES	—
Annex B	Type 3 (synchronous): exemplary FCS implementations	YES	—
Annex C	Type 3: Exemplary token procedure and message transfer periods	YES	—

Table 132 – CP 3/1: DLL protocol selection of Clause 5

Clause	Header	Presence	Constraints
5.1	General	YES	—
5.2	Overview of the medium access control and transmission protocol	YES	—
5.3	Transmission mode and DL entity	YES	—
5.4	Service assumed from the PhL	—	—
5.4.1	Asynchronous transmission	YES	—
5.4.2	Synchronous transmission	NO	—
5.5	Operational elements	—	—
5.5.1	Overview	YES	—
5.5.2	Bit time t_{BIT}	YES	—
5.5.3	Asynchronous transmission	YES	—
5.5.4	Synchronous transmission	NO	—
5.5.5	Timers and counters	—	—
5.5.5.1	Asynchronous transmission	YES	—
5.5.5.2	Synchronous transmission	NO	—
5.6	Cycle and system reaction times	—	—
5.6.1	Asynchronous transmission	YES	—
5.6.2	Synchronous transmission	NO	—

Table 133 – CP 3/1: DLL protocol selection of Clause 6

Clause	Header	Presence	Constraints
6.1	DLPDU granularity	—	—
6.1.1	Asynchronous transmission – UART character	YES	—
6.1.2	Synchronous transmission	NO	—
6.2	Length octet (LE, LEr)	YES	—
6.3	Address octet	YES	—
6.4	Control octet (FC)	YES	—
6.5	DLPDU content error detection	—	—
6.5.1	Asynchronous transmission – frame checksum (FCS)	YES	—
6.5.2	Synchronous transmission -frame check sequence (FCS)	NO	—
6.6	DATA_UNIT	YES	—
6.7	Error control procedures	—	—
6.7.1	Asynchronous transmission	YES	—
6.7.2	Synchronous transmission	NO	—

Table 134 – CP 3/1: DLL protocol selection of Clause 7

Clause	Header	Presence	Constraints
7.1	DLPDUs of fixed length with no data field	—	—
7.1.1	Asynchronous transmission	YES	—
7.1.2	Synchronous transmission	NO	—
7.2	DLPDUs of fixed length with data field	—	—
7.2.1	Asynchronous transmission	YES	—
7.2.2	Synchronous transmission	NO	—
7.3	DLPDUs with variable data field length	—	—
7.3.1	Asynchronous transmission	YES	—
7.3.2	Synchronous transmission	NO	—
7.4	Token DLPDU	—	—
7.4.1	Asynchronous transmission	YES	—
7.4.2	Synchronous transmission	NO	—
7.5	ASP DLPDU	Partial	See Table 137, Table 141, Table 149, and Table 153
7.6	SYNCH DLPDU	Partial	See Table 137, Table 141, Table 149, and Table 153
7.7	Time Event (TE) DLPDU	Partial	See Table 137, Table 141, Table 149, and Table 153
7.8	Clock Value (CV) DLPDU	Partial	See Table 137, Table 141, Table 149, and Table 153
7.9	Transmission procedures	YES	—
7.9.1	Asynchronous transmission	YES	—
7.9.2	Synchronous transmission	NO	—

7.2.2.2.2 Selection for DP-master (class 1)

7.2.2.2.2.1 DP-V0 master (class 1)

Table 135 specifies the CP 3/1 selection of the time parameters of the Data-link protocol, which are part of DP-master (class 1) and using features named DP-V0.

Table 135 – CP 3/1: Time variable selection for DP-V0 master (class 1)

Clause	Variable name	Usage	Constraint
5.5.3.1	Synchronization time (T_{SYN})	M	—
5.5.3.2	Synchronization interval time (T_{SYNI})	M	—
5.5.3.3	Station delay time (T_{SDx})	M	—
5.5.3.4	Quiet time (T_{QUI})	M	—
5.5.3.5	Ready time (T_{RDY})	M	—
5.5.3.6	Safety margin (T_{SM})	M	—
5.5.3.7	Idle time (T_{IDx})	M	—
5.5.3.8	Transmission delay time (T_{TD})	M	—
5.5.3.9	Slot time (T_{SL})	M	—
5.5.3.10	Time-out T_{TO}	M	—
5.5.3.11	GAP update time (T_{GUD})	M	—
5.5.3.12	Isochronous Mode	—	—
5.5.3.13	Send delay time (T_{SD})	—	—
5.5.3.14	Receive delay time (T_{RD})	—	—
5.5.3.15	Clock synchronization interval time (T_{CSI})	—	—

Table 136 specifies the CP 3/1 selection of the timers and counters of the Data-link protocol, which are part of DP-master (class 1) and using features named DP-V0.

Table 136 – CP 3/1: Timer and counter selection for DP-V0 master (class 1)

Clause	Timer or counter	Usage	Constraint
5.5.5.1.1	token-rotation-timer	M	—
5.5.5.1.1	idle-timer	M	—
5.5.5.1.1	slot-timer	M	—
5.5.5.1.1	time-out-timer	M	—
5.5.5.1.1	syn-interval-timer	M	—
5.5.5.1.1	GAP-update-timer	M	—
5.5.5.1.1	isochronous-cycle-timer	—	—
5.5.5.1.1	passive-spare-timer	—	—
5.5.5.1.1	send-delay-timer	—	—
5.5.5.1.1	receive-delay-timer	—	—
5.5.5.1.2	DLPDU_sent_count	O	—
5.5.5.1.2	Retry_count	O	—
5.5.5.1.2	DLPDU_sent_count_sr	O	—
5.5.5.1.2	Error_count	O	—
5.5.5.1.2	SD_count	O	—
5.5.5.1.2	SD_error_count	O	—

Table 137 specifies the CP 3/1 selection of the types of DLPDUs of the Data-link protocol, which are part of DP-master (class 1) and using features named DP-V0.

Table 137 – CP 3/1: DLPDU selection for DP-V0 master (class 1)

Clause	DLPDU	Usage	Constraint
7.1.1	DLPDUs of fixed length with no data field	M	—
7.2.1	DLPDUs of fixed length with data field	M	Option for sending
7.3.1	DLPDUs with variable data field length	M	—
7.4.1	Token DLPDU	M	—
7.5	ASP DLPDU	—	—
7.6	SYNCH DLPDU	—	—
7.7	Time Event (TE) DLPDU	—	—
7.8	Clock Value (CV) DLPDU	—	—

Table 138 specifies the CP 3/1 selection of the states of the media access control of the Data-link protocol, which are part of DP-master (class 1) and using features named DP-V0.

Table 138 – CP 3/1: MAC state selection for DP-V0 master (class 1)

Clause	MAC state	Usage	Constraint
8.2.2	Offline	M	—
8.2.3	Passive_Idle	O	—
8.2.4	Listen-Token	M	—
8.2.5	Active_Idle	M	—
8.2.6	Claim-Token	M	—
8.2.7	Wait_T _{CT}	—	—
8.2.8	Use-Token	M	—
8.2.9	Await_Data_Response	M	—
8.2.10	Check_Access_Time	M	—
8.2.11	Pass-Token	M	—
8.2.12	Check-Token_Pass	M	—
8.2.13	Await_Status_Response	M	—

The CP 3/1 selection of the clock synchronization protocol of the DL-entity of the Data-link protocol, which are part of DP-master (class 1) and using features named DP-V0, is empty.

7.2.2.2.2 DP-V1 master (class 1)

Table 139 specifies the CP 3/1 selection of the time parameters of the Data-link protocol, which are part of DP-master (class 1) and using features named DP-V1 and options.

Table 139 – CP 3/1: Time selection for DP-V1 master (class 1)

Clause	Times	Usage	Constraint
5.5.3.1	Synchronization time (T_{SYN})	M	—
5.5.3.2	Synchronization interval time (T_{SYNI})	M	—
5.5.3.3	Station delay time (T_{SDx})	M	—
5.5.3.4	Quiet time (T_{QUI})	M	—
5.5.3.5	Ready time (T_{RDY})	M	—
5.5.3.6	Safety margin (T_{SM})	M	—
5.5.3.7	Idle time (T_{idx})	M	—
5.5.3.8	Transmission delay time (T_{TD})	M	—
5.5.3.9	Slot time (T_{SL})	M	—
5.5.3.10	Time-out (T_{TO})	M	—
5.5.3.11	GAP update time (T_{GUD})	M	—
5.5.3.12.1	Isochronous cycle time (T_{CT})	O	—
5.5.3.12.2	IsoM synchronization message time (T_{SYNCH})	O	—
5.5.3.12.3	Active spare time message time (T_{ASM})	O	—
5.5.3.12.4	Real isochronous cycle time (T_{RCT})	O	—
5.5.3.12.5	Spare time (T_{RES})	O	—
5.5.3.12.6	Passive spare time (T_{PSP})	O	—
5.5.3.12.7	Time shift (T_{SH})	O	—
5.5.3.13	Send delay time (T_{SD})	O	—
5.5.3.14	Receive delay time (T_{RD})	O	—
5.5.3.15	Clock synchronization interval time (T_{CSI})	O	—

Table 140 specifies the CP 3/1 selection of the timers and counters of the Data-link protocol, which are part of DP-master (class 1) and using features named DP-V1 and options.

Table 140 – CP 3/1: Timer and counter selection for DP-V1 master (class 1)

Clause	Timer or counter	Usage	Constraint
5.5.5.1.1	token-rotation-timer	M	—
5.5.5.1.1	idle-timer	M	—
5.5.5.1.1	slot-timer	M	—
5.5.5.1.1	time-out-timer	M	—
5.5.5.1.1	syn-interval-timer	M	—
5.5.5.1.1	GAP-update-timer	M	—
5.5.5.1.1	isochronous-cycle-timer	O	—
5.5.5.1.1	passive-spare-timer	O	—
5.5.5.1.1	send-delay-timer	O	—
5.5.5.1.1	receive-delay-timer	O	—
5.5.5.1.2	DLPDU_sent_count	O	—
5.5.5.1.2	Retry_count	O	—
5.5.5.1.2	DLPDU_sent_count_sr	O	—
5.5.5.1.2	Error_count	O	—
5.5.5.1.2	SD_count	O	—
5.5.5.1.2	SD_error_count	O	—

Table 141 specifies the CP 3/1 selection of the types of DLPDUs of the Data-link protocol, which are part of DP-master (class 1) and using features named DP-V1 and Options.

Table 141 – CP 3/1: DLPDU selection for DP-V1 master (class 1)

Clause	DLPDU	Usage	Constraint
7.1.1	DLPDUs of fixed length with no data field	M	—
7.2.1	DLPDUs of fixed length with data field	M	Option for sending
7.3.1	DLPDUs with variable data field length	M	—
7.4.1	Token DLPDU	M	—
7.5	ASP DLPDU	O	—
7.6	SYNCH DLPDU	O	—
7.7	Time Event (TE) DLPDU	O	—
7.8	Clock Value (CV) DLPDU	O	—

Table 142 specifies the CP 3/1 selection of the states of the media access control of the Data-link protocol, which are part of DP-master (class 1) and using features named DP-V1 and Options.

Table 142 – CP 3/1: MAC state selection for DP-V1 master (class 1)

Clause	MAC state	Usage	Constraint
8.2.2	Offline	M	—
8.2.3	Passive_Idle	O	—
8.2.4	Listen-Token	M	—
8.2.5	Active_Idle	M	—
8.2.6	Claim-Token	M	—
8.2.7	Wait_T _{CT}	O	—
8.2.8	Use-Token	M	—
8.2.9	Await_Data_Response	M	—
8.2.10	Check_Access_Time	M	—
8.2.11	Pass-Token	M	—
8.2.12	Check-Token_Pass	M	—
8.2.13	Await_Status_Response	M	—

Table 143 specifies the CP 3/1 selection of the clock synchronization protocol of the Data-link protocol, which are part of DP-master (class 1) and using features named DP-V1 and Options.

Table 143 – CP 3/1: CS protocol selection for DP-V1 master (class 1)

Clause	Header	Usage	Constraint
8.3.1	Overview	O	—
8.3.2	State machine time master	O	—
8.3.3	State machine time receiver	O	—

7.2.2.2.3 Selection for DP-master (class 2)

7.2.2.2.3.1 DP-V0 master (class 2)

The CP 3/1 selection of the time parameters, of timers and counters, of DLPDUs, of states of the media access control and of the clock synchronization protocol, which are part of DP-master (class 2) and using features named DP-V0, are the same as specified for DP-V0-master (class 1) in 7.2.2.2.2.1.

7.2.2.2.3.2 DP-V1 master (class 2)

Table 144 specifies the CP 3/1 selection of the time parameters of the Data-link protocol, which are part of DP-master (class 2) and using features named DP-V1 and options.

Table 144 – CP 3/1: Time selection for DP-V1 master (class 2)

Clause	Times	Usage	Constraint
5.5.3.1	Synchronization time (T_{SYN})	M	—
5.5.3.2	Synchronization interval time (T_{SYNI})	M	—
5.5.3.3	Station delay time (T_{SDx})	M	—
5.5.3.4	Quiet time (T_{QUI})	M	—
5.5.3.5	Ready time (T_{RDY})	M	—
5.5.3.6	Safety margin (T_{SM})	M	—
5.5.3.7	Idle time (T_{IDx})	M	—
5.5.3.8	Transmission delay time (T_{TD})	M	—
5.5.3.9	Slot time (T_{SL})	M	—
5.5.3.10	Time-out T_{TO}	M	—
5.5.3.11	GAP update time (T_{GUD})	M	—
5.5.3.12	Isochronous mode	—	—
5.5.3.13	Send delay time (T_{SD})	O	—
5.5.3.14	Receive delay time (T_{RD})	O	—
5.5.3.15	Clock synchronization interval time (T_{CSI})	O	—

Table 145 specifies the CP 3/1 selection of the timers and counters of the Data-link protocol, which are part of DP-master (class 2) and using features named DP-V1 and options.

Table 145 – CP 3/1: Timer and counter selection for DP-V1 master (class 2)

Clause	Timer or counter	Usage	Constraint
5.5.5.1.1	token-rotation-timer	M	—
5.5.5.1.1	idle-timer	M	—
5.5.5.1.1	slot-timer	M	—
5.5.5.1.1	time-out-timer	M	—
5.5.5.1.1	syn-interval-timer	M	—
5.5.5.1.1	GAP-update-timer	M	—
5.5.5.1.1	isochronous-cycle-timer	—	—
5.5.5.1.1	passive-spare-timer	—	—
5.5.5.1.1	send-delay-timer	O	—
5.5.5.1.1	receive-delay-timer	O	—
5.5.5.1.2	DLPDU_sent_count	O	—
5.5.5.1.2	Retry_count	O	—
5.5.5.1.2	DLPDU_sent_count_sr	O	—
5.5.5.1.2	Error_count	O	—
5.5.5.1.2	SD_count	O	—
5.5.5.1.2	SD_error_count	O	—

Table 146 specifies the CP 3/1 selection of the types of DLPDUs of the Data-link protocol, which are part of DP-master (class 2) and using features named DP-V1 and options.

Table 146 – CP 3/1: DLPDU selection for DP-V1 master (class 2)

Clause	DLPDU	Usage	Constraint
7.1.1	DLPDUs of fixed length with no data field	M	—
7.2.1	DLPDUs of fixed length with data field	M	Option for sending
7.3.1	DLPDUs with variable data field length	M	—
7.4.1	Token DLPDU	M	—
7.5	ASP DLPDU	—	—
7.6	SYNCH DLPDU	—	—
7.7	Time Event (TE) DLPDU	O	—
7.8	Clock Value (CV) DLPDU	O	—

For Clause 8 the following constraints apply:

- a) The CP 3/1 selection of states of the media access, which are part of DP-master (class 2) and using features named DP-V1 and options, are the same as specified for DP-V0-master (class 1) in Table 138.
- b) The CP 3/1 selection of the clock synchronization protocol, which are part of DP-master (class 2) and using features named DP-V1 and options, are the same as specified for DP-V1-master (class 1) in Table 143.

7.2.2.2.4 Selection for DP-slave

7.2.2.2.4.1 DP-V0 slave

Table 147 specifies the CP 3/1 selection of the time parameters of the Data-link protocol, which are part of DP-slave and using features named DP-V0.

Table 147 – CP 3/1: Time selection for DP-V0 slave

Clause	Times	Usage	Constraint
5.5.3.1	Synchronization time (T_{SYN})	M	—
5.5.3.2	Synchronization interval time (T_{SYNI})	M	—
5.5.3.3	Station delay time (T_{SDx})	M	—
5.5.3.4	Quiet time (T_{QUI})	—	—
5.5.3.5	Ready time (T_{RDY})	—	—
5.5.3.6	Safety margin (T_{SM})	—	—
5.5.3.7	Idle time (T_{IDx})	M	—
5.5.3.8	Transmission delay time (T_{TD})	—	—
5.5.3.9	Slot time (T_{SL})	M	—
5.5.3.10	Time-out T_{TO}	M	—
5.5.3.11	GAP update time (T_{GUD})	—	—
5.5.3.12	Isochronous mode	—	—
5.5.3.13	Send delay time (T_{SD})	—	—
5.5.3.14	Receive delay time (T_{RD})	—	—
5.5.3.15	Clock synchronization interval time (T_{CSI})	—	—

Table 148 specifies the CP 3/1 selection of the timers and counters of the Data-link protocol, which are part of DP-slave and using features named DP-V0.

Table 148 – CP 3/1: Timer and counter selection for DP-V0 slave

Clause	Timer or counter	Usage	Constraint
5.5.5.1.1	token-rotation-timer	—	—
5.5.5.1.1	idle-timer	M	—
5.5.5.1.1	slot-timer	—	—
5.5.5.1.1	time-out-timer	M	—
5.5.5.1.1	syn-interval-timer	M	—
5.5.5.1.1	GAP-update-timer	—	—
5.5.5.1.1	isochronous-cycle-timer	—	—
5.5.5.1.1	passive-spare-timer	—	—
5.5.5.1.1	send-delay-timer	—	—
5.5.5.1.1	receive-delay-timer	—	—
5.5.5.1.2	DLPDU_sent_count	—	—
5.5.5.1.2	Retry_count	—	—
5.5.5.1.2	DLPDU_sent_count_sr	—	—
5.5.5.1.2	Error_count	—	—
5.5.5.1.2	SD_count	O	—
5.5.5.1.2	SD_error_count	O	—

Table 149 specifies the CP 3/1 selection of the types of DLPDUs of the Data-link protocol, which are part of DP-slave and using features named DP-V0.

Table 149 – CP 3/1: DLPDU selection for DP-V0 slave

Clause	DLPDU	Usage	Constraint
7.1.1	DLPDUs of fixed length with no data field	M	—
7.2.1	DLPDUs of fixed length with data field	M	Option for sending
7.3.1	DLPDUs with variable data field length	M	—
7.4.1	Token DLPDU	M	Only for receiving
7.5	ASP DLPDU	—	—
7.6	SYNCH DLPDU	—	—
7.7	Time Event (TE) DLPDU	—	—
7.8	Clock Value (CV) DLPDU	—	—

Table 150 specifies the CP 3/1 selection of the states of the media access control of the Data-link protocol, which are part of DP-slave and using features named DP-V0.

Table 150 – CP 3/1: MAC state selection for DP-V0 slave

Clause	MAC state	Usage	Constraint
8.2.2	Offline	M	—
8.2.3	Passive_Idle	M	—
8.2.4	Listen-Token	—	—
8.2.5	Active_Idle	—	—
8.2.6	Claim-Token	—	—
8.2.7	Wait_TCT	—	—
8.2.8	Use-Token	—	—
8.2.9	Await_Data_Response	—	—
8.2.10	Check_Access_Time	—	—
8.2.11	Pass-Token	—	—
8.2.12	Check-Token_Pass	—	—
8.2.13	Await_Status_Response	—	—

The CP 3/1 selection of the clock synchronization protocol of the DL-entity of the Data-link protocol, which are part of DP-slave and using features named DP-V0, is empty.

7.2.2.2.4.2 DP-V1 slave

Table 151 specifies the CP 3/1 selection of the time parameters of the Data-link protocol, which are part of DP-slave and using features named DP-V1 and options.

Table 151 – CP 3/1: Time selection for DP-V1 slave

Clause	Times	Usage	Constraint
5.5.3.1	Synchronization time (T_{SYN})	M	—
5.5.3.2	Synchronization interval time (T_{SYNI})	M	—
5.5.3.3	Station delay time (T_{SDx})	M	—
5.5.3.4	Quiet time (T_{QUI})	—	—
5.5.3.5	Ready time (T_{RDY})	—	—
5.5.3.6	Safety margin (T_{SM})	—	—
5.5.3.7	Idle time (T_{IDx})	M	—
5.5.3.8	Transmission delay time (T_{TD})	—	—
5.5.3.9	Slot time (T_{SL})	M	—
5.5.3.10	Time-out T_{TO}	M	—
5.5.3.11	GAP update time (T_{GUD})	—	—
5.5.3.12	Isochronous mode	—	—
5.5.3.13	Send delay time (T_{SD})	O	—
5.5.3.14	Receive delay time (T_{RD})	O	—
5.5.3.15	Clock synchronization interval time (T_{CSI})	O	—

Table 152 specifies the CP 3/1 selection of the timers and counters of the Data-link protocol, which are part of DP-slave and using features named DP-V1 and options.

Table 152 – CP 3/1: Timer and counter selection for DP-V1 slave

Clause	Timer or counter	Usage	Constraint
5.5.5.1.1	token-rotation-timer	—	—
5.5.5.1.1	idle-timer	M	—
5.5.5.1.1	slot-timer	—	—
5.5.5.1.1	time-out-timer	M	—
5.5.5.1.1	syn-interval-timer	M	—
5.5.5.1.1	GAP-update-timer	—	—
5.5.5.1.1	isochronous-cycle-timer	—	—
5.5.5.1.1	passive-spare-timer	—	—
5.5.5.1.1	send-delay-timer	—	—
5.5.5.1.1	receive-delay-timer	O	—
5.5.5.1.2	DLPDU_sent_count	—	—
5.5.5.1.2	Retry_count	—	—
5.5.5.1.2	DLPDU_sent_count_sr	—	—
5.5.5.1.2	Error_count	—	—
5.5.5.1.2	SD_count	O	—
5.5.5.1.2	SD_error_count	O	—

Table 153 specifies the CP 3/1 selection of the types of DLPDUs of the Data-link protocol, which are part of DP-slave and using features named DP-V1 and Options.

Table 153 – CP 3/1: DLPDU selection for DP-V1 slave

Clause	DLPDU	Usage	Constraint
7.1.1	DLPDUs of fixed length with no data field	M	—
7.2.1	DLPDUs of fixed length with data field	M	Option for sending
7.3.1	DLPDUs with variable data field length	M	—
7.4.1	Token DLPDU	M	Only for receiving
7.5	ASP DLPDU	O	Only for receiving
7.6	SYNCH DLPDU	O	Only for receiving
7.7	Time Event (TE) DLPDU	O	Only for receiving
7.8	Clock Value (CV) DLPDU	O	Only for receiving

The CP 3/1 selection of states of the media access, which are part of DP-slave and using features named DP-V1 and Options, are the same as specified for DP-V0-slave in Table 150.

Table 154 specifies the CP 3/1 selection of the clock synchronization protocol of the Data-link protocol, which are part of DP-slave and using features named DP-V1 and Options.

Table 154 – CP 3/1: CS protocol selection for DP-V1 slave

Clause	Header	Usage	Constraint
8.3.1	Overview	O	—
8.3.2	State machine time master	—	—
8.3.3	State machine time receiver	O	—

7.2.3 Application layer

7.2.3.1 AL service selection

7.2.3.1.1 General selection

NOTE In the application layer there is no difference between Profile 3/1 and Profile 3/2, therefore the header of the tables contain the term CP 3/1 and CP 3/2.

Table 155 specifies the selection of the application layer services within IEC 61158-5-3.

Table 155 – CP 3/1, 3/2: AL service selection

Clause	Header	Presence	Constraints
1	Scope	YES	—
2	Normative references	Partial	Used if referenced
3	Terms, definitions, abbreviations, symbols and conventions	Partial	Used when applicable
4	Concepts	YES	—
5	Data type ASE	YES	—
6	Communication model specification	Partial	See 7.2.3.1.2, 7.2.3.1.3, and 7.2.3.1.4

7.2.3.1.2 DP-master (Class 1)

7.2.3.1.2.1 DP-V0

Table 156 specifies CP 3/1 and 3/2 ASEs, which are part of DP-master (Class 1) and using features named DP-V0 and Options (see 7.2.3.2.5).

Table 156 – CP 3/1, 3/2: AL service selection of Clause 6

Clause	Header	Presence	Constraints
6.1	DP concepts	YES	—
6.2	ASEs	—	—
6.2.1	Process data ASE	NO	—
6.2.2	I/O data ASE	Partial	See Table 157
6.2.3	Diagnosis ASE	Partial	See Table 158
6.2.4	Alarm ASE	NO	—
6.2.5	Context ASE	Partial	See Table 159
6.2.6	Management ASE	Partial	See Table 160
6.2.7	Load region ASE	NO	—
6.2.8	Function invocation ASE	NO	—
6.2.9	Time ASE	NO	—
6.2.10	AR ASE	Partial	See Table 161
6.3	Summary of FAL classes	YES	—
6.4	Permitted FAL services by AREP role	YES	—
6.5	Conformance classes	YES	—
6.6	Application characteristics	YES	—

Table 157 – CP 3/1, 3/2: AL service selection of I/O data ASE

Clause	Header	Presence	Constraints
6.2.2.1	Overview	YES	—
6.2.2.2	I/O data class specification	NO	—
6.2.2.3	I/O data service specification	—	—
6.2.2.3.1	Set input	NO	—
6.2.2.3.2	Read input	NO	—
6.2.2.3.3	Get input	YES	—
6.2.2.3.4	New input	YES	—
6.2.2.3.5	Set output	YES	—
6.2.2.3.6	Read output	NO	—
6.2.2.3.7	Get output	NO	—
6.2.2.3.8	New output	NO	—
6.2.2.3.9	Global control	YES	Only request and confirm primitives and see 7.2.3.2.5.4
6.2.2.3.10	New publisher data	NO	—
6.2.2.3.11	Get publisher data	NO	—
6.2.2.3.12	SYNCH	NO	—
6.2.2.3.13	SYNCH delayed	NO	—
6.2.2.3.14	DX finished	NO	—
6.2.2.3.15	SYNCH event	NO	—
6.2.2.4	Behavior of I/O data objects	NO	—

Table 158 – CP 3/1, 3/2: AL service selection of Diagnosis ASE

Clause	Header	Presence	Constraints
6.2.3.1	Overview	YES	—
6.2.3.2	Diagnosis class specification	NO	—
6.2.3.3	Diagnosis service specification	—	—
6.2.3.3.1	Set slave diag	NO	—
6.2.3.3.2	Get slave diag	YES	—
6.2.3.3.3	Read slave diag	NO	—
6.2.3.3.4	New slave diag	YES	—

Table 159 – CP 3/1, 3/2: AL service selection of Context ASE

Clause	Header	Presence	Constraints
6.2.5.1	Overview	YES	—
6.2.5.2	Context class specification	NO	—
6.2.5.3	Context service specification	—	—
6.2.5.3.1 – 6.2.5.3.22		NO	—
6.2.5.3.23	Init DP master CI1	YES	—
6.2.5.3.24	DP master CI1 started	YES	Only for MS0 AR
6.2.5.3.25	DP master CI1 stopped	YES	Only for MS0 AR
6.2.5.3.26	Reset DP master CI1	YES	—
6.2.5.3.27	DP master CI1 fault	YES	—
6.2.5.3.28	DP master CI1 reject	NO	—
6.2.5.3.29	Set mode DP master CI1	YES	—
6.2.5.3.30	DP master CI1 mode changed	YES	—
6.2.5.3.31	Load bus Par DP master CI1	YES	—
6.2.5.3.32	Mark DP master CI1	YES	—
6.2.5.3.33	Abort DP master CI1	YES	—
6.2.5.3.34	Read value DP master CI1	YES	—
6.2.5.3.35	Delete SC DP master CI1	YES	—
6.2.5.3.36	DP master CI1 event	YES	—
6.2.5.3.37	Init DP master CI2	NO	—
6.2.5.3.38	Reset DP master CI2	NO	—
6.2.5.3.39	DP master CI2 Fault	NO	—
6.2.5.3.40	DP master CI2 Reject	NO	—
6.2.5.3.41	DP master CI2 closed	NO	—
6.2.5.3.42	DP master CI2 event	NO	—

Table 160 – CP 3/1, 3/2: AL service selection of Management ASE

Clause	Header	Presence	Constraints
6.2.6.1	Overview	YES	—
6.2.6.2	Management class specification	—	—
6.2.6.2.1	Master diag class specification	YES	—
6.2.6.2.2	Master parameter class specification	YES	See also 7.2.3.2.5.7 only for DP-V1
6.2.6.3	Management service specification	—	—
6.2.6.3.1	Get master diag	YES	Only indication and response primitives
6.2.6.3.2	Start Seq	YES	Only indication and response primitives
6.2.6.3.3	Download	YES	Only indication and response primitives
6.2.6.3.4	Upload	YES	Only indication and response primitives
6.2.6.3.5	End Seq	YES	Only indication and response primitives
6.2.6.3.6	Act Para Brct	YES	Only indication primitive
6.2.6.3.7	Act Para	YES	Only indication and response primitives

Table 161 – CP 3/1, 3/2: AL service selection of AR ASE

Clause	Header	Presence	Constraints
6.2.10.1	Overview	YES	—
6.2.10.2	Fieldbus ARs	—	—
6.2.10.2.1	MS0 application relationship	YES	—
6.2.10.2.2	MS1 application relationship	NO	—
6.2.10.2.3	MS2 application relationship	NO	—
6.2.10.2.4	MS3 application relationship	NO	—
6.2.10.2.5	MM1 application relationship	YES	—
6.2.10.2.6	MM2 application relationship	YES	—
6.2.10.3	Application relationship class specification	—	—
6.2.10.3.1	ARL DP-slave class specification	NO	—
6.2.10.3.2	ARL DP-master (class 1) class specification	YES	—
6.2.10.3.3	ARL DP-master (class 2) class specification	NO	—
6.2.10.4	Communication relationship class specification	—	—
6.2.10.4.1	CRL DP-slave class specification	NO	—
6.2.10.4.2	CRL DP-master (class 1) class specification	YES	See 7.2.3.2.5.1
6.2.10.4.3	CRL DP-master (class 2) class specification	NO	—
6.2.10.5	AR service specification	—	—
6.2.10.5.1	DLL Init DP slave	NO	—
6.2.10.5.2	Load ARL DP slave	NO	—
6.2.10.5.3	Get ARL DP slave	NO	—
6.2.10.5.4	Set ARL isochronous mode	NO	—
6.2.10.5.5	Load ARL DP master CI1	YES	—
6.2.10.5.6	Get ARL DP master CI1	YES	—
6.2.10.5.7	ARL slave update DP master CI1	NO	—
6.2.10.5.8	Load ARL DP master CI2	NO	—
6.2.10.5.9	Get ARL DP master CI2	NO	—
6.2.10.5.10	Load CRL DP slave	NO	—
6.2.10.5.11	Load CRL DXB link entries	NO	—
6.2.10.5.12	Get CRL DP slave	NO	—
6.2.10.5.13	Load CRL DP master CI1	YES	—
6.2.10.5.14	Get CRL DP master CI1	YES	—
6.2.10.5.15	CRL Slave activate	YES	—
6.2.10.5.16	CRL Slave New Prm	YES	—
6.2.10.5.17	CRL Slave New Prm Data	YES	—
6.2.10.5.18	Load CRL DP master CI2	NO	—
6.2.10.5.19	Get CRL DP master CI2	NO	—

7.2.3.1.2.2 DP-V1

Table 162 specifies CP 3/1 and CP 3/2: ASEs, which are part of DP-master (Class 1) and using features named DP-V1 and Options (see 7.2.3.2.5).

NOTE If a device supports DP-V1 features and Options, then it is to specify within the communication feature list of this device type (GSD-file).

Table 162 – CP 3/1, 3/2: AL service selection of Clause 6

Clause	Header	Presence	Constraints
6.1	DP concepts	YES	—
6.2	ASEs	—	—
6.2.1	Process data ASE	Partial	See Table 163 and 7.2.3.2.5.1
6.2.2	I/O data ASE	Partial	See Table 164
6.2.3	Diagnosis ASE	Partial	See Table 158
6.2.4	Alarm ASE	Partial	See Table 165 and 7.2.3.2.5.2
6.2.5	Context ASE	Partial	See Table 166
6.2.6	Management ASE	Partial	See Table 160
6.2.7	Load region ASE	Partial	See Table 167 and 7.2.3.2.5.8
6.2.8	Function invocation ASE	Partial	See Table 168 and 7.2.3.2.5.9
6.2.9	Time ASE	Partial	See Table 169 and 7.2.3.2.5.10
6.2.10	AR ASE	Partial	See Table 170
6.3	Summary of FAL classes	YES	—
6.4	Permitted FAL services by AREP role	YES	—
6.5	Conformance classes	YES	—
6.6	Application characteristics	YES	—

Table 163 – CP 3/1, 3/2: AL service selection of Process data ASE

Clause	Header	Presence	Constraints
6.2.1.1	Overview	YES	—
6.2.1.2	Process data class specification	NO	—
6.2.1.3	Access protection on process data objects	NO	—
6.2.1.4	Process data service specification	—	—
6.2.1.4.1	Read	YES	Only request and confirm primitives
6.2.1.4.2	Write	YES	Only request and confirm primitives
6.2.1.4.3	Data transport	NO	—

Table 164 – CP 3/1, 3/2: AL service selection of I/O data ASE

Clause	Header	Presence	Constraints
6.2.2.1	Overview	YES	—
6.2.2.2	I/O data class specification	NO	—
6.2.2.3	I/O data service specification	—	—
6.2.2.3.1	Set input	NO	—
6.2.2.3.2	Read input	NO	—
6.2.2.3.3	Get input	YES	—
6.2.2.3.4	New input	YES	—
6.2.2.3.5	Set output	YES	—
6.2.2.3.6	Read output	NO	—
6.2.2.3.7	Get output	NO	—
6.2.2.3.8	New output	NO	—
6.2.2.3.9	Global control	YES	Only request and confirm primitives and see 7.2.3.2.5.4
6.2.2.3.10	New publisher data	NO	—
6.2.2.3.11	Get publisher data	NO	—
6.2.2.3.12	SYNCH	YES	—
6.2.2.3.13	SYNCH delayed	YES	—
6.2.2.3.14	DX finished	YES	—
6.2.2.3.15	SYNCH event	NO	—
6.2.2.4	Behavior of I/O data objects	Partial	Only for isochronous mode, see 7.2.3.2.5.5

Table 165 – CP 3/1, 3/2: AL service selection of Alarm ASE

Clause	Header	Presence	Constraints
6.2.4.1	Overview	YES	—
6.2.4.2	Alarm class specification	NO	—
6.2.4.3	Alarm service specification	—	—
6.2.4.3.1	Alarm notification	YES	Only indication primitive
6.2.4.3.2	Alarm Ack	YES	Only request and confirm primitives

Table 166 – CP 3/1, 3/2: AL service selection of Context ASE

Clause	Header	Presence	Constraints
6.2.5.1	Overview	YES	—
6.2.5.2	Context class specification	NO	—
6.2.5.3	Context service specification	—	—
6.2.5.3.1 – 6.2.5.3.22	—	NO	—
6.2.5.3.23 – 6.2.5.3.36	—	YES	—
6.2.5.3.37 – 6.2.5.3.42	Init DP master CI2	NO	—

Table 167 – CP 3/1, 3/2: AL service selection of Load region ASE

Clause	Header	Presence	Constraints
6.2.7.1	Overview	YES	—
6.2.7.2	Load region class specification	NO	—
6.2.7.3	Load region service specification	—	—
6.2.7.3.1	Initiate load	YES	Only request and confirm primitives
6.2.7.3.2	Push segment	YES	Only request and confirm primitives
6.2.7.3.3	Pull segment	YES	Only request and confirm primitives
6.2.7.3.4	Terminate load	YES	Only request and confirm primitives
6.2.7.4	Behavior of the load region object	NO	—

Table 168 – CP 3/1, 3/2: AL service selection of Function invocation ASE

Clause	Header	Presence	Constraints
6.2.8.1	Overview	YES	—
6.2.8.2	Function invocation model class specification	NO	—
6.2.8.3	Function invocation service specification	—	—
6.2.8.3.1	Start	YES	Only request and confirm primitives
6.2.8.3.2	Stop	YES	Only request and confirm primitives
6.2.8.3.3	Resume	YES	Only request and confirm primitives
6.2.8.3.4	Reset	YES	Only request and confirm primitives
6.2.8.3.5	Get FI state	YES	Only request and confirm primitives
6.2.8.3.6	Call	YES	Only request and confirm primitives
6.2.8.4	Behavior of the function invocation object	NO	—

Table 169 – CP 3/1, 3/2: AL service selection of Time ASE

Clause	Header	Presence	Constraints
6.2.9.1	Overview	YES	—
6.2.9.2	Time class specification	—	—
6.2.9.2.1	Slave time class specification	NO	—
6.2.9.2.2	Link time class specification	YES	—
6.2.9.3	Time service specification	—	—
6.2.9.3.1	Set time	YES	—
6.2.9.3.2	Sync interval violation	NO	—

Table 170 – CP 3/1, 3/2: AL service selection of AR ASE

Clause	Header	Presence	Constraints
6.2.10.1	Overview	YES	—
6.2.10.2	Type 3 fieldbus ARs	—	—
6.2.10.2.1	MS0 application relationship	YES	—
6.2.10.2.2	MS1 application relationship	YES	—
6.2.10.2.3	MS2 application relationship	NO	—
6.2.10.2.4	MS3 application relationship	YES	—
6.2.10.2.5	MM1 application relationship	YES	—
6.2.10.2.6	MM2 application relationship	YES	—
6.2.10.3	Application relationship class specification	—	—
6.2.10.3.1	ARL DP-slave class specification	NO	—
6.2.10.3.2	ARL DP-master (class 1) class specification	YES	—
6.2.10.3.3	ARL DP-master (class 2) class specification	NO	—
6.2.10.4	Communication relationship class specification	—	—
6.2.10.4.1	CRL DP-slave class specification	NO	—
6.2.10.4.2	CRL DP-master (class 1) class specification	YES	—
6.2.10.4.3	CRL DP-master (class 2) class specification	NO	—
6.2.10.5	AR service specification	—	—
6.2.10.5.1	DLL init DP slave	NO	—
6.2.10.5.2	Load ARL DP slave	NO	—
6.2.10.5.3	Get ARL DP slave	NO	—
6.2.10.5.4	Set ARL isochronous mode	NO	—
6.2.10.5.5	Load ARL DP master CI1	YES	—
6.2.10.5.6	Get ARL DP master CI1	YES	—
6.2.10.5.7	ARL slave update DP master CI1	YES	—
6.2.10.5.8	Load ARL DP master CI2	NO	—
6.2.10.5.9	Get ARL DP master CI2	NO	—
6.2.10.5.10	Load CRL DP slave	NO	—
6.2.10.5.11	Load CRL DXB Link entries	NO	—
6.2.10.5.12	Get CRL DP slave	NO	—
6.2.10.5.13	Load CRL DP master CI1	YES	—
6.2.10.5.14	Get CRL DP master CI1	YES	—
6.2.10.5.15	CRL Slave activate	YES	—
6.2.10.5.16	CRL Slave New Prm	YES	—
6.2.10.5.17	CRL Slave New Prm Data	YES	—
6.2.10.5.18	Load CRL DP master CI2	NO	—
6.2.10.5.19	Get CRL DP master CI2	NO	—

7.2.3.1.3 DP-master (Class 2)

7.2.3.1.3.1 DP-V0

Table 171 specifies CP 3/1 and CP 3/2: ASEs, which are part of DP-master (Class 2) and using features named DP-V0 and Options (see 7.2.3.2.5).

Table 171 – CP 3/1, 3/2: AL service selection of Clause 6

Clause	Header	Presence	Constraints
6.1	DP concepts	YES	—
6.2	ASEs	—	—
6.2.1	Process data ASE	NO	—
6.2.2	I/O data ASE	Partial	See Table 172
6.2.3	Diagnosis ASE	Partial	See Table 173
6.2.4	Alarm ASE	NO	—
6.2.5	Context ASE	Partial	See Table 174
6.2.6	Management ASE	Partial	See Table 175
6.2.7	Load region ASE	NO	—
6.2.8	Function invocation ASE	NO	—
6.2.9	Time ASE	NO	—
6.2.10	AR ASE	Partial	See Table 176
6.3	Summary of AL classes	YES	—
6.4	Permitted AL services by AREP	YES	—
6.5	Conformance classes	YES	—
6.6	Application characteristics	YES	—

Table 172 – CP 3/1, 3/2: AL service selection of I/O data ASE

Clause	Header	Presence	Constraints
6.2.2.1	Overview	YES	—
6.2.2.2	I/O data class specification	NO	—
6.2.2.3	I/O data service specification	—	—
6.2.2.3.1	Set input	NO	—
6.2.2.3.2	Read input	YES	Only request and confirm primitives
6.2.2.3.3	Get input	NO	—
6.2.2.3.4	New input	NO	—
6.2.2.3.5	Set output	NO	—
6.2.2.3.6	Read output	YES	Only request and confirm primitives
6.2.2.3.7	Get output	NO	—
6.2.2.3.8	New output	NO	—
6.2.2.3.9	Global control	NO	—
6.2.2.3.10	New publisher data	NO	—
6.2.2.3.11	Get publisher data	NO	—
6.2.2.3.12	SYNCH	NO	—
6.2.2.3.13	SYNCH delayed	NO	—
6.2.2.3.14	DX finished	NO	—
6.2.2.3.15	SYNCH event	NO	—
6.2.2.4	Behavior of I/O data objects	NO	—

Table 173 – CP 3/1, 3/2: AL service selection of Diagnosis ASE

Clause	Header	Presence	Constraints
6.2.3.1	Overview	YES	—
6.2.3.2	Diagnosis class specification	NO	—
6.2.3.3	Diagnosis service specification	—	—
6.2.3.3.1	Set slave Diag	NO	—
6.2.3.3.2	Get slave Diag	NO	—
6.2.3.3.3	Read slave Diag	YES	—
6.2.3.3.4	New slave Diag	NO	—

Table 174 – CP 3/1, 3/2: AL service selection of Context ASE

Clause	Header	Presence	Constraints
6.2.5.1	Overview	YES	—
6.2.5.2	Context class specification	NO	—
6.2.5.3	Context service specification	—	—
6.2.5.3.1	Check user Prm	NO	—
6.2.5.3.2	Check user Prm result	NO	—
6.2.5.3.3	Check Ext user Prm	NO	—
6.2.5.3.4	Check Ext user Prm result	NO	—
6.2.5.3.5	Check Cfg	NO	—
6.2.5.3.6	Check Cfg result	NO	—
6.2.5.3.7	Set Cfg	NO	—
6.2.5.3.8	Get Cfg	YES	—
6.2.5.3.9	Set slave Add	YES	Only request and confirm primitives
6.2.5.3.10 – 6.2.5.3.36	—	NO	—
6.2.5.3.37	Init DP master CI2	YES	—
6.2.5.3.38	Reset DP master CI2	YES	—
6.2.5.3.39	DP master CI2 Fault	YES	—
6.2.5.3.40	DP master CI2 Reject	NO	—
6.2.5.3.41	DP master CI2 Closed	NO	—
6.2.5.3.42	DP master CI2 Event	YES	—

Table 175 – CP 3/1, 3/2: AL service selection of Management ASE

Clause	Header	Presence	Constraints
6.2.6.1	Overview	YES	—
6.2.6.2	Management class specification	NO	—
6.2.6.3	Management service specification	—	—
6.2.6.3.1	Get master Diag	YES	Only request and confirm primitives
6.2.6.3.2	Start Seq	YES	Only request and confirm primitives
6.2.6.3.3	Download	YES	Only request and confirm primitives and see 7.2.3.2.5.7 only for DP-V1
6.2.6.3.4	Upload	YES	Only request and confirm primitives
6.2.6.3.5	End Seq	YES	Only request and confirm primitives
6.2.6.3.6	Act Para Brct	YES	Only request primitive
6.2.6.3.7	Act Para	YES	Only request and confirm primitives

Table 176 – CP 3/1, 3/2: AL service selection of AR ASE

Clause	Header	Presence	Constraints
6.2.10.1	Overview	YES	—
6.2.10.2	Type 3 Fieldbus ARs	—	—
6.2.10.2.1	MS0 application relationship	YES	—
6.2.10.2.2	MS1 application relationship	NO	—
6.2.10.2.3	MS2 application relationship	NO	—
6.2.10.2.4	MS3 application relationship	NO	—
6.2.10.2.5	MM1 application relationship	YES	—
6.2.10.2.6	MM2 application relationship	YES	—
6.2.10.3	Application relationship class specification	—	—
6.2.10.3.1	ARL DP-slave class specification	NO	—
6.2.10.3.2	ARL DP-master (class 1) class specification	NO	—
6.2.10.3.3	ARL DP-master (class 2) class specification	YES	—
6.2.10.4	Communication relationship class specification	—	—
6.2.10.4.1	CRL DP-slave class specification	NO	—
6.2.10.4.2	CRL DP-master (class 1) class specification	NO	—
6.2.10.4.3	CRL DP-master (class 2) class specification	YES	—
6.2.10.5	AR service specification	—	—
6.2.10.5.1	DLL Init DP slave	NO	—
6.2.10.5.2	Load ARL DP slave	NO	—
6.2.10.5.3	Get ARL DP slave	NO	—
6.2.10.5.4	Set ARL isochronous mode	NO	—
6.2.10.5.5	Load ARL DP master CI1	NO	—
6.2.10.5.6	Get ARL DP master CI1	NO	—
6.2.10.5.7	ARL slave update DP master CI1	NO	—

Clause	Header	Presence	Constraints
6.2.10.5.8	Load ARL DP master CI2	YES	—
6.2.10.5.9	Get ARL DP master CI2	YES	—
6.2.10.5.10	Load CRL DP slave	NO	—
6.2.10.5.11	Load CRL DXB Link entries	NO	—
6.2.10.5.12	Get CRL DP slave	NO	—
6.2.10.5.13	Load CRL DP master CI1	NO	—
6.2.10.5.14	Get CRL DP master CI1	NO	—
6.2.10.5.15	CRL slave Activate	NO	—
6.2.10.5.16	CRL slave New Prm	NO	—
6.2.10.5.17	CRL slave New Prm data	NO	—
6.2.10.5.18	Load CRL DP master CI2	YES	—
6.2.10.5.19	Get CRL DP master CI2	YES	—

7.2.3.1.3.2 DP-V1

Table 177 specifies CP 3/1 and CP 3/2: ASEs, which are part of DP-master (Class 2) and using features named DP-V1 and Options (see 7.2.3.2.5).

NOTE If a device supports DP-V1 features and Options, then it is to specify within the communication feature list of this device type (GSD-file).

Table 177 – CP 3/1, 3/2: AL service selection of Clause 6

Clause	Header	Presence	Constraints
6.1	DP concepts	YES	—
6.2	ASEs	—	—
6.2.1	Process data ASE	Partial	See Table 178 and 7.2.3.2.5.1
6.2.2	I/O data ASE	Partial	See Table 172
6.2.3	Diagnosis ASE	Partial	See Table 173
6.2.4	Alarm ASE	NO	—
6.2.5	Context ASE	Partial	See Table 179
6.2.6	Management ASE	Partial	See Table 175
6.2.7	Load region ASE	Partial	See Table 180 and 7.2.3.2.5.8
6.2.8	Function invocation ASE	Partial	See Table 181 and 7.2.3.2.5.9
6.2.9	Time ASE	Partial	See Table 182 and 7.2.3.2.5.10
6.2.10	AR ASE	Partial	See Table 183
6.3	Summary of FAL classes	YES	—
6.4	Permitted FAL services by AREP role	YES	—
6.5	Conformance classes	YES	—
6.6	Application characteristics	YES	—

Table 178 – CP 3/1, 3/2: AL service selection of Process data ASE

Clause	Header	Presence	Constraints
6.2.1.1	Overview	YES	—
6.2.1.2	Process data class specification	NO	—
6.2.1.3	Access protection on process data objects	NO	—
6.2.1.4	Process data service specification	—	—
6.2.1.4.1	Read	YES	Only request and confirm primitives
6.2.1.4.2	Write	YES	Only request and confirm primitives
6.2.1.4.3	Data transport	YES	Only request and confirm primitives

Table 179 – CP 3/1, 3/2: AL service selection of Context ASE

Clause	Header	Presence	Constraints
6.2.5.1	Overview	YES	—
6.2.5.2	Context class specification	NO	—
6.2.5.3	Context service specification	—	—
6.2.5.3.1	Check user Prm	NO	—
6.2.5.3.2	Check user Prm Result	NO	—
6.2.5.3.3	Check Ext user Prm	NO	—
6.2.5.3.4	Check Ext user Prm Result	NO	—
6.2.5.3.5	Check Cfg	NO	—
6.2.5.3.6	Check Cfg result	NO	—
6.2.5.3.7	Set Cfg	NO	—
6.2.5.3.8	Get Cfg	YES	—
6.2.5.3.9	Set slave Add	YES	Only request and confirm primitives
6.2.5.3.10	Initiate	YES	Only request and confirm primitives
6.2.5.3.11	Abort	YES	—
6.2.5.3.12 – 6.2.5.3.36	—	NO	—
6.2.5.3.37	Init DP master CI2	YES	—
6.2.5.3.38	Reset DP master CI2	YES	—
6.2.5.3.39	DP master CI2 fault	YES	—
6.2.5.3.40	DP master CI2 reject	YES	—
6.2.5.3.41	DP master CI2 closed	YES	—
6.2.5.3.42	DP master CI2 event	YES	—

Table 180 – CP 3/1, 3/2: AL service selection of Load region ASE

Clause	Header	Presence	Constraints
6.2.7.1	Overview	YES	—
6.2.7.2	Load region class specification	NO	—
6.2.7.3	Load region service specification	—	—
6.2.7.3.1	Initiate load	YES	Only request and confirm primitives
6.2.7.3.2	Push segment	YES	Only request and confirm primitives
6.2.7.3.3	Pull segment	YES	Only request and confirm primitives
6.2.7.3.4	Terminate load	YES	Only request and confirm primitives
6.2.7.4	Behavior of the load region object	NO	—

Table 181 – CP 3/1, 3/2: AL service selection of Function invocation ASE

Clause	Header	Presence	Constraints
6.2.8.1	Overview	YES	—
6.2.8.2	Function invocation model class specification	NO	—
6.2.8.3	Function invocation service specification	—	—
6.2.8.3.1	Start	YES	Only request and confirm primitives
6.2.8.3.2	Stop	YES	Only request and confirm primitives
6.2.8.3.3	Resume	YES	Only request and confirm primitives
6.2.8.3.4	Reset	YES	Only request and confirm primitives
6.2.8.3.5	Get FI state	YES	Only request and confirm primitives
6.2.8.3.6	Call	YES	Only request and confirm primitives
6.2.8.4	Behavior of the function Invocation object	NO	—

Table 182 – CP 3/1, 3/2: AL service selection of Time ASE

Clause	Header	Presence	Constraints
6.2.9.1	Overview	YES	—
6.2.9.2	Time class specification	—	—
6.2.9.2.1	slave time class specification	NO	—
6.2.9.2.2	Link time class specification	YES	—
6.2.9.3	Time service specification	—	—
6.2.9.3.1	Set time	YES	—
6.2.9.3.2	Sync Interval violation	NO	—

Table 183 – CP 3/1, 3/2: AL service selection of AR ASE

Clause	Header	Presence	Constraints
6.2.10.1	Overview	YES	—
6.2.10.2	Fieldbus ARs	—	—
6.2.10.2.1	MS0 application relationship	YES	—
6.2.10.2.2	MS1 application relationship	NO	—
6.2.10.2.3	MS2 application relationship	YES	—
6.2.10.2.4	MS3 application relationship	YES	—
6.2.10.2.5	MM1 application relationship	YES	—
6.2.10.2.6	MM2 application relationship	YES	—
6.2.10.3	Application relationship class specification	—	—
6.2.10.3.1	ARL DP-slave class specification	NO	—
6.2.10.3.2	ARL DP-master (class 1) class specification	NO	—
6.2.10.3.3	ARL DP-master (class 2) class specification	YES	—
6.2.10.4	Communication relationship class specification	—	—
6.2.10.4.1	CRL DP-slave class specification	NO	—
6.2.10.4.2	CRL DP-master (class 1) class specification	NO	—
6.2.10.4.3	CRL DP-master (class 2) class specification	YES	—
6.2.10.5	AR service specification	—	—
6.2.10.5.1	DLL Init DP slave	NO	—
6.2.10.5.2	Load ARL DP slave	NO	—
6.2.10.5.3	Get ARL DP slave	NO	—
6.2.10.5.4	Set ARL isochronous mode	NO	—
6.2.10.5.5	Load ARL DP master CI1	NO	—
6.2.10.5.6	Get ARL DP master CI1	NO	—
6.2.10.5.7	ARL slave update DP master CI1	NO	—
6.2.10.5.8	Load ARL DP master CI2	YES	—
6.2.10.5.9	Get ARL DP master CI2	YES	—
6.2.10.5.10	Load CRL DP slave	NO	—
6.2.10.5.11	Load CRL DXB link entries	NO	—
6.2.10.5.12	Get CRL DP slave	NO	—
6.2.10.5.13	Load CRL DP master CI1	NO	—
6.2.10.5.14	Get CRL DP master CI1	NO	—
6.2.10.5.15	CRL Slave activate	NO	—
6.2.10.5.16	CRL Slave New Prm	NO	—
6.2.10.5.17	CRL Slave New Prm Data	NO	—
6.2.10.5.18	Load CRL DP master CI2	YES	—
6.2.10.5.19	Get CRL DP master CI2	YES	—

7.2.3.1.4 DP-slave**7.2.3.1.4.1 DP-V0**

Table 184 specifies CP 3/1 and CP 3/2: ASEs, which are part of DP-slave and using features named DP-V0 and Options (see 7.2.3.2.5).

Table 184 – CP 3/1, 3/2: AL service selection of Clause 6

Clause	Header	Presence	Constraints
6.1	DP concepts	YES	—
6.2	ASEs	—	—
6.2.1	Process data ASE	NO	—
6.2.2	I/O data ASE	Partial	See Table 185
6.2.3	Diagnosis ASE	Partial	See Table 186
6.2.4	Alarm ASE	NO	—
6.2.5	Context ASE	Partial	See Table 187
6.2.6	Management ASE	NO	—
6.2.7	Load region ASE	NO	—
6.2.8	Function invocation ASE	NO	—
6.2.9	Time ASE	NO	—
6.2.10	AR ASE	Partial	See Table 188
6.3	Summary of FAL classes	YES	—
6.4	Permitted FAL services by AREP role	YES	See 7.2.3.2.5
6.5	Conformance classes	YES	—
6.6	Application characteristics	YES	—

Table 185 – CP 3/1, 3/2: AL service selection of I/O data ASE

Clause	Header	Presence	Constraints
6.2.2.1	Overview	YES	—
6.2.2.2	I/O data class specification	YES	—
6.2.2.3	I/O data service specification	—	—
6.2.2.3.1	Set input	YES	—
6.2.2.3.2	Read input	NO	—
6.2.2.3.3	Get input	NO	—
6.2.2.3.4	New input	NO	—
6.2.2.3.5	Set output	NO	—
6.2.2.3.6	Read output	NO	—
6.2.2.3.7	Get output	YES	—
6.2.2.3.8	New output	YES	—
6.2.2.3.9	Global control	YES	Only indication primitive
6.2.2.3.10	New publisher data	NO	—
6.2.2.3.11	Get publisher data	NO	—
6.2.2.3.12	SYNCH	NO	—
6.2.2.3.13	SYNCH delayed	NO	—
6.2.2.3.14	DX finished	NO	—
6.2.2.3.15	SYNCH event	NO	—
6.2.2.4	Behavior of I/O data objects	—	—
6.2.2.4.1	General behavior of the output data object	YES	—
6.2.2.4.2	Characteristics of a DP system with isochronous mode functionality	NO	—
6.2.2.4.3	Application model of the DP-master (Class 1) with isochronous mode functionality	NO	—
6.2.2.4.4	Output data state machine description for isochronous mode	NO	—
6.2.2.4.5	Behavior of the input data object	YES	—
6.2.2.4.6	Input data state machine description for isochronous mode	NO	—

Table 186 – CP 3/1, 3/2: AL service selection of Diagnosis ASE

Clause	Header	Presence	Constraints
6.2.3.1	Overview	YES	—
6.2.3.2	Diagnosis class specification	—	—
6.2.3.2.1	Device related diagnosis class specification	YES	—
6.2.3.2.2	Identifier related diagnosis class specification	YES	—
6.2.3.2.3	Channel related diagnosis class specification	YES	—
6.2.3.2.4	Status class specification	NO	—
6.2.3.2.5	Module status class specification	NO	—
6.2.3.2.6	DXB-Link status class specification	NO	—
6.2.3.3	Diagnosis service specification	—	—
6.2.3.3.1	Set slave Diag	YES	—
6.2.3.3.2	Get slave Diag	NO	—
6.2.3.3.3	Read slave Diag	NO	—
6.2.3.3.4	New slave Diag	NO	—

Table 187 – CP 3/1, 3/2: AL service selection of Context ASE

Clause	Header	Presence	Constraints
6.2.5.1	Overview	YES	—
6.2.5.2	Context class specification	—	—
6.2.5.2.1	MS0 user parameter class specification	YES	—
6.2.5.2.2	MS0 structured user parameter class specification	NO	—
6.2.5.2.3	DXB-Linktable class specification	NO	—
6.2.5.2.4	DXB-Subscribertable class specification	NO	—
6.2.5.2.5	IsoM ParameterClass Specification	NO	—
6.2.5.2.6	Time AR parameter class specification	YES	—
6.2.5.2.7	MS0 configuration elements class specification	YES	—
6.2.5.2.8	Remanent parameter class specification	YES	Optional
6.2.5.2.9	MS2 user parameter class specification	NO	—
6.2.5.2.10	Red Context class specification		Optional
6.2.5.3	Context service specification	—	—
6.2.5.3.1	Check User Prm	YES	—
6.2.5.3.2	Check User Prm result	YES	—
6.2.5.3.3	Check Ext User Prm	NO	—
6.2.5.3.4	Check Ext User Prm result	NO	—
6.2.5.3.5	Check Cfg	YES	—
6.2.5.3.6	Check Cfg result	YES	—
6.2.5.3.7	Set Cfg	YES	—
6.2.5.3.8	Get Cfg	NO	—
6.2.5.3.9	Set slave Add	YES	Only indication primitive
6.2.5.3.10	Initiate	NO	—
6.2.5.3.11	Abort	NO	—
6.2.5.3.12	MS0 Init DP slave	YES	—
6.2.5.3.13	MS1 Init DP slave	NO	—
6.2.5.3.14	M2 Init DP slave	NO	—
6.2.5.3.15	DP slave Started	NO	—
6.2.5.3.16	DP slave Stopped	YES	Only for MS0 AR
6.2.5.3.17	Reset DP slave	YES	—
6.2.5.3.18	DP slave fault	YES	—
6.2.5.3.19	Application Ready DP slave	YES	—
6.2.5.3.20 – 6.2.5.3.42	—	NO	—

Table 188 – CP 3/1, 3/2: AL service selection of AR ASE

Clause	Header	Presence	Constraints
6.2.10.1	Overview	YES	—
6.2.10.2	Fieldbus ARs	—	—
6.2.10.2.1	MS0 application relationship	YES	—
6.2.10.2.2	MS1 application relationship	NO	—
6.2.10.2.3	MS2 application relationship	NO	—
6.2.10.2.4	MS3 application relationship	NO	—
6.2.10.2.5	MM1 application relationship	NO	—
6.2.10.2.6	MM2 application relationship	NO	—
6.2.10.3	Application relationship class specification	—	—
6.2.10.3.1	ARL DP-slave class specification	YES	—
6.2.10.3.2	ARL DP-master (class 1) class specification	NO	—
6.2.10.3.3	ARL DP-master (class 2) class specification	NO	—
6.2.10.4	Communication relationship class specification	—	—
6.2.10.4.1	CRL DP-slave class specification	YES	—
6.2.10.4.2	CRL DP-master (class 1) class specification	NO	—
6.2.10.4.3	CRL DP-master (class 2) class specification	NO	—
6.2.10.5	AR service specification	—	—
6.2.10.5.1	DLL Init DP slave	YES	—
6.2.10.5.2	Load ARL DP slave	YES	—
6.2.10.5.3	Get ARL DP slave	YES	—
6.2.10.5.4	Set ARL isochronous mode	NO	—
6.2.10.5.5	Load ARL DP master CI1	NO	—
6.2.10.5.6	Get ARL DP master CI1	NO	—
6.2.10.5.7	ARL slave update DP master CI1	NO	—
6.2.10.5.8	Load ARL DP master CI2	NO	—
6.2.10.5.9	Get ARL DP master CI2	NO	—
6.2.10.5.10	Load CRL DP slave	YES	—
6.2.10.5.11	Load CRL DXB link entries	NO	—
6.2.10.5.12	Get CRL DP slave	YES	—
6.2.10.5.13	Load CRL DP master CI1	NO	—
6.2.10.5.14	Get CRL DP master CI1	NO	—
6.2.10.5.15	CRL Slave activate	NO	—
6.2.10.5.16	CRL Slave New Prm	NO	—
6.2.10.5.17	CRL Slave New Prm Data	NO	—
6.2.10.5.18	Load CRL DP master CI2	NO	—
6.2.10.5.19	Get CRL DP master CI2	NO	—

7.2.3.1.4.2 DP-V1

Table 189 specifies CP 3/1 and CP 3/2: ASEs, which are part of DP-slave and using features named DP-V1 and Options (see 7.2.3.2.5).

NOTE If a device supports DP-V1 features and Options, then it is to specify within the communication feature list of this device type (GSD-file).

Table 189 – CP 3/1, 3/2: AL service selection of Clause 6

Clause	Header	Presence	Constraints
6.1	DP concepts	YES	—
6.2	ASEs	—	—
6.2.1	Process data ASE	Partial	See Table 190 and 7.2.3.2.5.1
6.2.2	I/O data ASE	Partial	See Table 191
6.2.3	Diagnosis ASE	Partial	See Table 192
6.2.4	Alarm ASE	Partial	See Table 193 and 7.2.3.2.5.2
6.2.5	Context ASE	Partial	See Table 194
6.2.6	Management ASE	NO	—
6.2.7	Load region ASE	Partial	See Table 195 and 7.2.3.2.5.8
6.2.8	Function invocation ASE	Partial	See Table 196 and 7.2.3.2.5.9
6.2.9	Time ASE	Partial	See Table 197 and 7.2.3.2.5.10
6.2.10	AR ASE	Partial	See Table 198
6.3	Summary of FAL classes	YES	—
6.4	Permitted FAL services by AREP role	YES	—
6.5	Conformance classes	YES	—
6.6	Application characteristics	YES	—

Table 190 – CP 3/1, 3/2: AL service selection of Process data ASE

Clause	Header	Presence	Constraints
6.2.1.1	Overview	YES	—
6.2.1.2	Process data class specification	YES	—
6.2.1.3	Access protection on process data objects	YES	—
6.2.1.4	Process data service specification	—	—
6.2.1.4.1	Read	YES	Only indication and response primitives
6.2.1.4.2	Write	YES	Only indication and response primitives
6.2.1.4.3	Data transport	YES	Only indication and response primitives

Table 191 – CP 3/1, 3/2: AL service selection of I/O data ASE

Clause	Header	Presence	Constraints
6.2.2.1	Overview	YES	—
6.2.2.2	I/O data class specification	YES	—
6.2.2.3	I/O data service specification	—	—
6.2.2.3.1	Set input	YES	—
6.2.2.3.2	Read input	NO	—
6.2.2.3.3	Get input	NO	—
6.2.2.3.4	New input	NO	—
6.2.2.3.5	Set output	NO	—
6.2.2.3.6	Read output	NO	—
6.2.2.3.7	Get output	YES	—
6.2.2.3.8	New output	YES	—
6.2.2.3.9	Global control	YES	Only indication primitive
6.2.2.3.10	New publisher data	YES	—
6.2.2.3.11	Get publisher data	YES	—
6.2.2.3.12	SYNCH	NO	—
6.2.2.3.13	SYNCH delayed	NO	—
6.2.2.3.14	DX finished	NO	—
6.2.2.3.15	SYNCH event	YES	—
6.2.2.4	Behavior of I/O data objects	YES	See also 7.2.3.2.5.5

Table 192 – CP 3/1, 3/2: AL service selection of diagnosis ASE

Clause	Header	Presence	Constraints
6.2.3.1	Overview	YES	—
6.2.3.2	Diagnosis class specification	—	—
6.2.3.2.1	Device related diagnosis class specification	NO	—
6.2.3.2.2	Identifier related diagnosis class specification	YES	—
6.2.3.2.3	Channel related diagnosis class specification	YES	—
6.2.3.2.4	Status class specification	YES	—
6.2.3.2.5	Module status class specification	YES	—
6.2.3.2.6	DXB-Link status class specification	YES	—
6.2.3.3	Diagnosis service specification	—	—
6.2.3.3.1	Set slave Diag	YES	—
6.2.3.3.2	Get slave Diag	NO	—
6.2.3.3.3	Read slave Diag	NO	—
6.2.3.3.4	New slave Diag	NO	—

Table 193 – CP 3/1, 3/2: AL service selection of Alarm ASE

Clause	Header	Presence	Constraints
6.2.4.1	Overview	YES	—
6.2.4.2	Alarm class specification	YES	—
6.2.4.3	Alarm service specification	—	—
6.2.4.3.1	Alarm notification	YES	Only request and confirm primitives
6.2.4.3.2	Alarm Ack	YES	Only indication and response primitives

Table 194 – CP 3/1, 3/2: AL service selection of Context ASE

Clause	Header	Presence	Constraints
6.2.5.1	Overview	YES	—
6.2.5.2	Context class specification	—	—
6.2.5.2.1	MS0 user parameter class specification	YES	—
6.2.5.2.2	MS0 structured user parameter class specification	YES	See also 7.2.3.2.5.7
6.2.5.2.3	DXB-Linktable class specification	YES	—
6.2.5.2.4	DXB-Subscribertable class specification	YES	—
6.2.5.2.5	IsoM parameterclass specification	YES	—
6.2.5.2.6	MS0 configuration elements class specification	YES	—
6.2.5.2.7	Remanent parameter class specification	YES	—
6.2.5.2.8	MS2 user parameter class specification	YES	—
6.2.5.3	Context service specification	—	—
6.2.5.3.1	Check User Prm	YES	—
6.2.5.3.2	Check User Prm result	YES	—
6.2.5.3.3	Check Ext User Prm	YES	—
6.2.5.3.4	Check Ext User Prm result	YES	—
6.2.5.3.5	Check Cfg	YES	—
6.2.5.3.6	Check Cfg result	YES	—
6.2.5.3.7	Set Cfg	YES	—
6.2.5.3.8	Get Cfg	NO	—
6.2.5.3.9	Set slave Add	YES	Only indication primitive
6.2.5.3.10	Initiate	YES	Only indication and response primitives
6.2.5.3.11	Abort	YES	—
6.2.5.3.12	MS0 Init DP slave	YES	—
6.2.5.3.13	MS1 Init DP slave	YES	—
6.2.5.3.14	M2 Init DP slave	YES	—
6.2.5.3.15	DP slave started	YES	—
6.2.5.3.16	DP slave stopped	YES	—
6.2.5.3.17	Reset DP slave	YES	—
6.2.5.3.18	DP slave fault	YES	—
6.2.5.3.19	Application Ready DP slave	YES	—

Clause	Header	Presence	Constraints
6.2.5.3.20	Start subscriber	YES	—
6.2.5.3.21	Stop subscriber	YES	—
6.2.5.3.22	Publisher active	YES	—
6.2.5.3.23 – 6.2.5.3.42	—	NO	—

Table 195 – CP 3/1, 3/2: AL service selection of Load region ASE

Clause	Header	Presence	Constraints
6.2.7.1	Overview	YES	—
6.2.7.2	Load region class specification	YES	—
6.2.7.3	Load region service specification	—	—
6.2.7.3.1	Initiate load	YES	Only indication and response primitives
6.2.7.3.2	Push segment	YES	Only indication and response primitives
6.2.7.3.3	Pull segment	YES	Only indication and response primitives
6.2.7.3.4	Terminate load	YES	Only indication and response primitives
6.2.7.4	Behavior of the load region object	YES	—

Table 196 – CP 3/1, 3/2: AL service selection of Function invocation ASE

Clause	Header	Presence	Constraints
6.2.8.1	Overview	YES	—
6.2.8.2	Function invocation model class specification	YES	—
6.2.8.3	Function invocation service specification	—	—
6.2.8.3.1	Start	YES	Only indication and response primitives
6.2.8.3.2	Stop	YES	Only indication and response primitives
6.2.8.3.3	Resume	YES	Only indication and response primitives
6.2.8.3.4	Reset	YES	Only indication and response primitives
6.2.8.3.5	Get FI state	YES	Only indication and response primitives
6.2.8.3.6	Call	YES	Only indication and response primitives
6.2.8.4	Behavior of the function invocation object	YES	—

Table 197 – CP 3/1, 3/2: AL service selection of Time ASE

Clause	Header	Presence	Constraints
6.2.9.1	Overview	YES	—
6.2.9.2	Time class specification	—	—
6.2.9.2.1	Slave time class specification	YES	—
6.2.9.2.2	Link time class specification	NO	—
6.2.9.3	Time service specification	—	—
6.2.9.3.1	Set time	YES	Only indication primitive
6.2.9.3.2	Sync interval violation	YES	—

Table 198 – CP 3/1, 3/2: AL service selection of AR ASE

Clause	Header	Presence	Constraints
6.2.10.1	Overview	YES	—
6.2.10.2	Type 3 fieldbus ARs	—	—
6.2.10.2.1	MS0 application relationship	YES	—
6.2.10.2.2	MS1 application relationship	YES	—
6.2.10.2.3	MS2 application relationship	YES	—
6.2.10.2.4	MS3 application relationship	YES	—
6.2.10.2.5	MM1 application relationship	NO	—
6.2.10.2.6	MM2 application relationship	NO	—
6.2.10.3	Application relationship class specification	—	—
6.2.10.3.1	ARL DP-slave class specification	YES	See 7.2.3.2.5.4
6.2.10.3.2	ARL DP-master (class 1) class specification	NO	—
6.2.10.3.3	ARL DP-master (class 2) class specification	NO	—
6.2.10.4	Communication relationship class specification	—	—
6.2.10.4.1	CRL DP-slave class specification	YES	—
6.2.10.4.2	CRL DP-master (class 1) class specification	NO	—
6.2.10.4.3	CRL DP-master (class 2) class specification	NO	—
6.2.10.5	AR service specification	—	—
6.2.10.5.1	DLL init DP slave	YES	—
6.2.10.5.2	Load ARL DP slave	YES	—
6.2.10.5.3	Get ARL DP slave	YES	—
6.2.10.5.4	Set ARL isochronous mode	YES	—
6.2.10.5.5	Load ARL DP master CI1	NO	—
6.2.10.5.6	Get ARL DP master CI1	NO	—
6.2.10.5.7	ARL slave update DP master CI1	NO	—
6.2.10.5.8	Load ARL DP master CI2	NO	—
6.2.10.5.9	Get ARL DP master CI2	NO	—
6.2.10.5.10	Load CRL DP slave	YES	—
6.2.10.5.11	Load CRL DXB Link entries	YES	—
6.2.10.5.12	Get CRL DP slave	YES	—
6.2.10.5.13	Load CRL DP master CI1	NO	—
6.2.10.5.14	Get CRL DP master CI1	NO	—
6.2.10.5.15	CRL Slave activate	NO	—
6.2.10.5.16	CRL Slave New Prm	NO	—
6.2.10.5.17	CRL Slave New Prm Data	NO	—
6.2.10.5.18	Load CRL DP master CI2	NO	—
6.2.10.5.19	Get CRL DP master CI2	NO	—

7.2.3.2 AL protocol selection

7.2.3.2.1 General selection

NOTE In the application layer there is no difference between Profile 3/1 and Profile 3/2, therefore the header of the tables contain the term CP 3/1 and CP 3/2.

Table 199 specifies the selection of the application layer protocol within IEC 61158-6-3.

Table 199 – CP 3/1, 3/2: AL protocol selection

Clause	Header	Presence	Constraints
1	Scope	—	—
2	Normative references	YES	—
3	Terms, definitions, abbreviations, symbols and conventions	Partial	Used when applicable
4	FAL syntax description	Partial	See 7.2.3.2.2, 7.2.3.2.3, and 7.2.3.2.4
5	Transfer syntax	Partial	See 7.2.3.2.2, 7.2.3.2.3, and 7.2.3.2.4
6	FAL protocol state machines	Partial	See 7.2.3.2.2, 7.2.3.2.3, and 7.2.3.2.4
7	AP-Context state machine	Partial	See 7.2.3.2.2, 7.2.3.2.3, and 7.2.3.2.4
8	FAL Service Protocol Machines (FSPMs)	Partial	See 7.2.3.2.2, 7.2.3.2.3, and 7.2.3.2.4
9	Application Relationship Protocol Machines (ARPMs)	Partial	See 7.2.3.2.2, 7.2.3.2.3, and 7.2.3.2.4
10	DLL Mapping Protocol Machines (DMPMs)	Partial	See 7.2.3.2.2, 7.2.3.2.3, and 7.2.3.2.4
11	Parameters for a DP-slave	Partial	See 7.2.3.2.2, 7.2.3.2.3, and 7.2.3.2.4

7.2.3.2.2 DP-master (Class 1)

7.2.3.2.2.1 DP-V0

Table 200 specifies the AL protocol, which is part of DP-master (Class 1) and using features named DP-V0.

Table 200 – CP 3/1, 3/2: AL protocol selection of Clause 4 to 11

Clause	Header	Presence	Constraints
4	FAL syntax description	—	—
4.1	APDU abstract syntax	Partial	See Table 201
4.2	Data types	Partial	Used when applicable
5	Transfer syntax	—	—
5.1	Coding of basic data types	YES	—
5.2	Coding section related to data exchange PDUs	YES	—
5.3	Coding section related to slave diagnosis PDUs	YES	—
5.4	Coding section related to parameterization PDU	YES	—
5.5	Coding section related to configuration PDUs	YES	—
5.6	Coding section related to global control PDUs	YES	—
5.7	Coding section related to clock-value-PDUs	NO	—
5.8	Coding section related to function identification and errors	YES	—
5.9	Coding section related to master diagnosis PDU	YES	—
5.10	Coding section related to Upload/download/act para PDUs	YES	—
5.11	Coding section related to the bus parameter set	YES	—
5.12	Coding section related to the slave parameter set	YES	—
5.13	Coding section related to statistic counters	YES	—
5.14	Coding section related to set slave address PDU	NO	—
5.15	Coding section related to initiate/abort PDUs	NO	—
5.16	Coding section related to read/write/data transport PDUs	NO	—
5.17	Coding section related to load region and function invocation PDUs	NO	—
5.18	Examples of diagnosis-RES-PDUs	NO	—
5.19	Example of Chk_Cfg-REQ-PDU	NO	—
5.20	Examples of Chk_Cfg-REQ-PDUs with DPV1 data types	NO	—
5.21	Example structure of the Data_Unit for Data_Exchange	NO	—
6	FAL protocol state machines	—	—
6.1	Overall structure	—	—
6.1.1	Fieldbus Service Protocol Machines (FSPM)	YES	—
6.1.2	Master to Slave cyclic (MS0)	YES	—
6.1.3	Master (class 1) to Slave acyclic (MS1)	YES	—
6.1.4	Master (class 2) to Slave acyclic (MS2)	YES	—
6.1.5	Master to Slave clock synchronization (MS3)	NO	—

Clause	Header	Presence	Constraints
6.1.6	Master Master acyclic (MM1/MM2)	NO	—
6.1.7	DLL Mapping Protocol Machines (DMPM)	NO	—
6.2	Assignment of state machines to devices	YES	—
6.3	Overview DP-slave	NO	—
6.4	Overview DP-master (class 1)	YES	—
6.5	Overview DP-master (class 2)	NO	—
6.6	Cyclic communication between DP-master (class 1) and DP-slave	YES	—
6.7	Acyclic communication between DP-master (class 2) and DP-master (class 1)	YES	—
6.8	Acyclic communication between DP-master (class 1) and DP-slave	—	—
6.9	Application relationship monitoring	—	—
6.9.1	Monitoring of the MS0 – AR	—	—
6.9.1.1	General	YES	—
6.9.1.2	Control interval at the DP-slave	NO	—
6.9.1.3	Control intervals at the DP-master (class 1)	YES	—
6.9.2	Monitoring of the MS2 – AR	NO	—
7	AP-Context state machine	NO	—
8	FAL Service Protocol Machines (FSPMs)	—	—
8.1	FSPMS	NO	—
8.2	FSPMM1	Partial	See Table 202
8.3	FSPMM2	NO	—
9	Application Relationship Protocol Machines (ARPMs)	—	—
9.1	MSCY1S	NO	—
9.2	MSAC1S	NO	—
9.3	SSCY1S	NO	—
9.4	MSRM2S	NO	—
9.5	MSAC2S	NO	—
9.6	MSCS1S	NO	—
9.7	MSCY1M	YES	—
9.8	MSAL1M	NO	—
9.9	MSAC1M	NO	—
9.10	MMAC1	YES	—
9.11	MSCS1M	NO	—
9.12	MSAC2M	NO	—
9.13	MMAC2	NO	—
10	DLL Mapping Protocol Machines (DMPMs)	—	—
10.1	DMPMS	NO	—
10.2	DMPMM1	Partial	See Table 203
10.3	DMPMM2	NO	—
11	Parameters for a DP-slave	NO	—

Table 201 – CP 3/1, 3/2: AL protocol selection of APDUs

Service name	Usage
DataExchange-REQ-PDU	E
DataExchange-RES-PDU	D
Chk_Cfg-REQ-PDU	E
Set_Prm-REQ-PDU	E
Diagnosis-RES-PDU	D
Global_Control-REQ-PDU	E
Get_Master_Diag-REQ-PDU	OE
Get_Master_Diag-RES-PDU	OD
Start_Seq-REQ-PDU	OE
Start_Seq-RES-PDU	OD
Download-REQ-PDU	OE
Download-RES-PDU	OD
Upload-REQ-PDU	OE
Upload-RES-PDU	OD
End_Seq-REQ-PDU	OE
End_Seq-RES-PDU	OD
Act_Para_Brct-REQ-PDU	OE
Act_Param-REQ-PDU	OD
Act_Param-RES-PDU	OE
<p>NOTE The abbreviations mean:</p> <p>O = Optional;</p> <p>M = Mandatory (default, if not marked as optional);</p> <p>D = Decode;</p> <p>E = Encode</p>	

Table 202 – CP 3/1, 3/2: AL protocol selection of FSPM services primitives

Service name	Usage
Init.req/cnf	M
Reset.req/cnf	M
Abort.req	M
Mark.req/cnf	M
Set Mode.req/cnf	M
Load Bus Par.req/cnf	M
Delete SC.req/cnf	O
Read Value.req/cnf	O
CRL slave Activate.req/cnf	M
CRL slave New Prm Data.req/cnf	M
CRL slave New Prm.req/cnf	M
Get slave Diag.req/cnf	M
Set Output.req/cnf	M
Get Input.req/cnf	M
Global Control.req/cnf	M
Get Master Diag.ind/rsp	O
Start Seq.ind/rsp	O
Download.ind/rsp	O
Upload.ind/rsp	O
End Seq.ind/rsp	O
Act Param.ind/rsp	O
Mode Changed.ind	M
Started.ind	M
Stopped.ind	M
Abort.ind	M
Reject.ind	M
Fault.ind	M
New slave Diag.ind	M
New Input.ind	M
Act Para Brct.ind	M
Event.ind	M

Table 203 – CP 3/1, 3/2: AL protocol selection of DMPM services primitives

Service Primitive Name	Usage
MInit DLL.req/cnf	M
Reset.req/cnf	M
Global Control.req/cnf	M
Set Bus Par.req/cnf	M
Delete SC.req/cnf	O
Read Value.req/cnf	O
Fault.ind	M
Event.ind	M
Slave Diag.req/cnf	M
Set Prm.req/cnf	M
Chk Cfg.req/cnf	M
Data Exchange.req/cnf	M
RSAP ACTIVATE.req/cnf	O
REPLY UPDATE.req/cnf	O
DATA REPLY.req/cnf/ind	O
DATA.ind	O

7.2.3.2.2.2 DP-V1

Table 204 specifies AL protocol, which is part of DP-master (Class 1) and using features named DP-V1 and options.

NOTE If a device supports DP-V1 features, then it is to specify within the communication feature list of this device type (GSD-file).

Table 204 – CP 3/1, 3/2: AL protocol selection of Clause 4 to 11

Clause	Header	Presence	Constraints
4	FAL syntax description	—	—
4.1	APDU abstract syntax	Partial	See Table 205
4.2	Data types	Partial	Used when applicable
5	Transfer syntax	—	—
5.1	Coding of basic data types	YES	—
5.2	Coding section related to data exchange PDUs	YES	—
5.3	Coding section related to slave diagnosis PDUs	YES	—
5.4	Coding section related to parameterization PDU	YES	—
5.5	Coding section related to configuration PDUs	YES	—
5.6	Coding section related to global control PDUs	YES	—
5.7	Coding section related to clock-value-PDUs	YES	—
5.8	Coding section related to function identification and errors	YES	—
5.9	Coding section related to master diagnosis PDU	YES	—
5.10	Coding section related to Upload/download/act para PDUs	YES	—
5.11	Coding section related to the bus parameter set	YES	—
5.12	Coding section related to the slave parameter set	YES	—
5.13	Coding section related to statistic counters	YES	—
5.14	Coding section related to set slave address PDU	NO	—
5.15	Coding section related to initiate/abort PDUs	NO	—
5.16	Coding section related to read/write/data transport PDUs	YES	—
5.17	Coding section related to load region and function invocation PDUs	YES	—
5.18	Examples of diagnosis-RES-PDUs	YES	—
5.19	Example of Chk_Cfg-REQ-PDU	YES	—
5.20	Examples of Chk_Cfg-REQ-PDUs with DPV1 data types	YES	—
5.21	Example structure of the Data_Unit for Data_Exchange	YES	—
6	FAL protocol state machines	—	—
6.1	Overall structure	YES	—
6.2	Assignment of state machines to devices	YES	—
6.3	Overview DP-slave	NO	—
6.4	Overview DP-master (class 1)	YES	—
6.5	Overview DP-master (class 2)	NO	—

Clause	Header	Presence	Constraints
6.6	Cyclic communication between DP-master (class 1) and DP-slave	YES	—
6.7	Acyclic communication between DP-master (class 2) and DP-master (class 1)	YES	—
6.8	Acyclic communication between DP-master (class 1) and DP-slave	YES	—
6.9	Application relationship monitoring	—	—
6.9.1	Monitoring of the MS0 – AR	—	—
6.9.1.1	General	YES	—
6.9.1.2	Control interval at the DP-slave	NO	—
6.9.1.3	Control intervals at the DP-master (class 1)	YES	—
6.9.2	Monitoring of the MS2 – AR	NO	—
7	AP-Context state machine	NO	—
8	FAL Service Protocol Machines (FSPMs)	—	—
8.1	FSPMS	NO	—
8.2	FSPMM1	Partial	See Table 206
8.3	FSPMM2	NO	—
9	Application Relationship Protocol Machines (ARPMs)	—	—
9.1	MSCY1S	NO	—
9.2	MSAC1S	NO	—
9.3	SSCY1S	NO	—
9.4	MSRM2S	NO	—
9.5	MSAC2S	NO	—
9.6	MSCS1S	NO	—
9.7	MSCY1M	YES	—
9.8	MSAL1M	YES	—
9.9	MSAC1M	YES	—
9.10	MMAC1	YES	—
9.11	MSCS1M	YES	—
9.12	MSAC2M	NO	—
9.13	MMAC2	NO	—
10	DLL Mapping Protocol Machines (DMPMs)	—	—
10.1	DMPMS	NO	—
10.2	DMPMM1	Partial	See Table 207
10.3	DMPMM2	NO	—
11	Parameters for a DP-slave	NO	—

Table 205 – CP 3/1, 3/2: AL protocol selection of APDUs

APDU Name	Decode / Encode
DataExchange-REQ-PDU	E
DataExchange-RES-PDU	D
Chk_Cfg-REQ-PDU	E
Set_Prm-REQ-PDU	E
Set_Ext_Prm-REQ-PDU	OE
Diagnosis-RES-PDU	D
Global_Control-REQ-PDU	E
Clock-Value-PDU	OD
Read-REQ-PDU	OE
Read-RES-PDU	OD
Read-NRS-PDU, Pull-NRS-PDU	OD
Write-REQ-PDU	OE
Write-RES-PDU	OD
Write-, Initiate_Load-, Push-, Terminate_Load, Start-, Stop-, Resume-, Reset-, Call-, Get_FI_State-NRS-PDU	OD
Alarm_Ack-REQ-PDU	OE
Alarm_Ack-RES-PDU	OD
Alarm_Ack-NRS-PDU	OD
Data_Transport-REQ-PDU	OE
Data_Transport-RES-PDU	OD
Data_Transport-NRS-PDU	OD
Initiate_Load-REQ-PDU	OE
Initiate_Load-RES-PDU	OD
Push-REQ-PDU	OE
Pull-REQ-PDU	OE
Pull-RES-PDU	OD
Terminate_Load-REQ-PDU	OE
Start-REQ-PDU	OE
Stop-REQ-PDU	OE
Resume-REQ-PDU	OE
Reset-REQ-PDU	OE
Call-REQ-PDU	OE
Call-RES-PDU	OD
Get_FI_State-REQ-PDU	OE
Get_FI_State-RES-PDU	OD
Push-, Terminate_Load-, Start-, Stop-, Resume-, Reset-RES- PDU	OD
Get_Master_Diag-REQ-PDU	OE
Get_Master_Diag-RES-PDU	OD
Start_Seq-REQ-PDU	OE
Start_Seq-RES-PDU	OD
Download-REQ-PDU	OE
Download-RES-PDU	OD

APDU Name	Decode / Encode
Upload-REQ-PDU	OE
Upload-RES-PDU	OD
End_Seq-REQ-PDU	OE
End_Seq-RES-PDU	OD
Act_Para_Brct-REQ-PDU	OE
Act_Param-REQ-PDU	OD
Act_Param-RES-PDU	OE
NOTE The abbreviations mean: O = Optional; M = Mandatory (default, if not marked as optional); D = Decode; E = Encode.	

Table 206 – CP 3/1, 3/2: AL protocol selection of FSPM services primitives

Service name	Usage
Init.req/cnf	M
Reset.req/cnf	M
Abort.req	M
Mark.req/cnf	M
Set Mode.req/cnf	M
Load Bus Par.req/cnf	M
Delete SC.req/cnf	O
Read Value.req/cnf	O
CRL slave Activate.req/cnf	M
CRL slave New Prm Data.req/cnf	M
CRL slave New Prm.req/cnf	M
Get slave Diag.req/cnf	M
Set Output.req/cnf	M
Get Input.req/cnf	M
Read.req/cnf	O
Write.req/cnf	O
Alarm Ack.req/cnf	O
Set Time.req/cnf	O
Initiate Load.req/cnf	O
Push Segment.req/cnf	O
Pull Segment.req/cnf	O
Terminate Load.req/cnf	O
Start.req/cnf	O
Stop.req/cnf	O
Resume.req/cnf	O
Reset.req/cnf	O
Call.req/cnf	O
Get FI State.req/cnf	O
Global Control.req/cnf	O

Service name	Usage
Get Master Diag.ind/rsp	O
Start Seq.ind/rsp	O
Download.ind/rsp	O
Upload.ind/rsp	O
End Seq.ind/rsp	O
Act Param.ind/rsp	O
SYNCH.ind	O
SYNCH Delayed.ind	O
DX Finished.ind	O
Set Time.ind	O
Sync Interval Violation.ind	O
Mode Changed.ind	O
Started.ind	O
Stopped.ind	O
Abort.ind	O
Reject.ind	O
Fault.ind	O
New slave Diag.ind	M
New Input.ind	M
Act Para Brct.ind	O
Event.ind	M
Alarm Notification.ind	O

Table 207 – CP 3/1, 3/2: AL protocol selection of DMPM services primitives

Service name	Usage
MInit DLL.req/cnf	M
Reset.req/cnf	M
Global Control.req/cnf	M
Set Bus Par.req/cnf	M
Delete SC.req/cnf	O
Read Value.req/cnf	O
Fault.ind	M
Event.ind	M
SYNCH.ind	O
SYNCH Delayed.ind	O
Slave Diag.req/cnf	M
Set Prm.req/cnf	M
Chk Cfg.req/cnf	M
Data Exchange.req/cnf	M
RSAP ACTIVATE.req/cnf	O
REPLY UPDATE.req/cnf	O
DATA REPLY.req/cnf/ind	O
DATA.ind	O
CS TIME EVENT.req/cnf	O
CS CLOCK VALUE.req/cnf/ind	O

7.2.3.2.3 DP-master (Class 2)

7.2.3.2.3.1 DP-V0

Table 208 specifies AL protocol, which is part of DP-master (Class 2) and using features named DP-V0.

Table 208 – CP 3/1, 3/2: AL protocol selection of Clause 4 to 6

Clause	Header	Presence	Constraints
4	FAL syntax description	—	—
4.1	APDU abstract syntax	Partial	See Table 209
4.2	Data types	Partial	Used when applicable
5	Transfer syntax	—	—
5.1	Coding of basic data types	YES	—
5.2	Coding section related to data exchange PDUs	YES	—
5.3	Coding section related to slave diagnosis PDUs	YES	—
5.4	Coding section related to parameterization PDU	NO	—
5.5	Coding section related to configuration PDUs	YES	—
5.6	Coding section related to global control PDUs	NO	—
5.7	Coding section related to clock-value-PDUs	NO	—
5.8	Coding section related to function identification and errors	YES	—
5.9	Coding section related to master diagnosis PDU	YES	—
5.10	Coding section related to Upload/download/act para PDUs	YES	—
5.11	Coding section related to the bus parameter set	YES	—
5.12	Coding section related to the slave parameter set	YES	—
5.13	Coding section related to statistic counters	YES	—
5.14	Coding section related to set slave address PDU	YES	—
5.15	Coding section related to initiate/abort PDUs	NO	—
5.16	Coding section related to read/write/data transport PDUs	NO	—
5.17	Coding section related to load region and function invocation PDUs	NO	—
5.18	Examples of diagnosis-RES-PDUs	NO	—
5.19	Example of Chk_Cfg-REQ-PDU	NO	—
5.20	Examples of Chk_Cfg-REQ-PDUs with DPV1 data types	NO	—
5.21	Example structure of the Data_Unit for Data_Exchange	NO	—
6	FAL protocol state machines	—	—
6.1	Overall structure	—	—
6.1.1	Fieldbus Service Protocol Machines (FSPM)	YES	—
6.1.2	Master to Slave cyclic (MS0)	YES	—
6.1.3	Master (class 1) to Slave acyclic (MS1)	YES	—
6.1.4	Master (class 2) to Slave acyclic (MS2)	YES	—
6.1.5	Master to Slave clock synchronization (MS3)	NO	—
6.1.6	Master Master acyclic (MM1/MM2)	NO	—
6.1.7	DLL Mapping Protocol Machines (DMPM)	NO	—
6.2	Assignment of state machines to devices	YES	—
6.3	Overview DP-slave	NO	—
6.4	Overview DP-master (class 1)	NO	—
6.5	Overview DP-master (class 2)	YES	—

Clause	Header	Presence	Constraints
6.6	Cyclic communication between DP-master (class 1) and DP-slave	NO	—
6.7	Acyclic communication between DP-master (class 2) and DP-master (class 1)	YES	—
6.8	Acyclic communication between DP-master (class 1) and DP-slave	NO	—
6.9	Application relationship monitoring	NO	—
7	AP-Context state machine	NO	—
8	FAL Service Protocol Machines (FSPMs)	—	—
8.1	FSPMS	NO	—
8.2	FSPMM1	NO	—
8.3	FSPMM2	Partial	See Table 210
9	Application Relationship Protocol Machines (ARPMs)	—	—
9.1 – 9.12	—	NO	—
9.13	MMAC2	YES	—
10	DLL Mapping Protocol Machines (DMPMs)	—	—
10.1	DMPMS	NO	—
10.2	DMPMM1	NO	—
10.3	DMPMM2	Partial	See Table 211
11	Parameters for a DP-slave	NO	—

Table 209 – CP 3/1, 3/2: AL protocol selection of APDUs

APDU Name	Decode / Encode
RD_Output-RES-PDU	OD
RD_Output-REQ-PDU	OE
RD_Input-RES-PDU	OD
RD_Input-REQ-PDU	OE
Get_Cfg-REQ-PDU	OE
Get_Cfg-RES-PDU	OD
Diagnosis-RES-PDU	OD
Diagnosis-REQ-PDU	OE
Set_Slave_Add-REQ-PDU	OE
Get_Master_Diag-REQ-PDU	OE
Get_Master_Diag-RES-PDU	OD
Start_Seq-REQ-PDU	OE
Start_Seq-RES-PDU	OD
Download-REQ-PDU	OE
Download-RES-PDU	OD
Upload-REQ-PDU	OE
Upload-RES-PDU	OD
End_Seq-REQ-PDU	OE
End_Seq-RES-PDU	OD
Act_Para_Brct-REQ-PDU	OE
Act_Param-REQ-PDU	OE
Act_Param-RES-PDU	OD
<p>NOTE The abbreviations mean:</p> <p>O = Optional;</p> <p>M = Mandatory (default, if not marked as optional);</p> <p>D = Decode;</p> <p>E = Encode.</p>	

Table 210 – CP 3/1, 3/2: AL protocol selection of FSPM services primitives

Service name	Usage
MInit.req/cnf	M
Reset.req/cnf	M
Abort.req	M
Read Slave Diag.req/cnf	M
Read Input.req/cnf	M
Read Output.req/cnf	M
Get Cfg.req/cnf	M
Set Slave Add.req/cnf	O
Get Master Diag.ind/rsp	O
Start Seq.ind/rsp	O
Download.ind/rsp	O
Upload.ind/rsp	O
End Seq.ind/rsp	O
Act Param.ind/rsp	O
Act Para Brct.ind	O
Abort.ind	M
Reject.ind	M
Fault.ind	M
Event.ind	M
NOTE The abbreviations mean: O = Optional; M = Mandatory (default, if not marked as optional); D = Decode; E = Encode.	

Table 211 – CP 3/1, 3/2: AL protocol selection of DMPM services primitives

Service name	Usage
MInit DLL.req/cnf	M
Reset.req/cnf	M
Read Slave Diag.req/cnf	O
Read Input.req/cnf	O
Read Output.req/cnf	O
Get Cfg.req/cnf	O
Set Slave Add.req/cnf	O
DATA.req/cnf	O
DATA REPLY.req/cnf	O
NOTE The abbreviations mean: O = Optional; M = Mandatory (default, if not marked as optional); D = Decode; E = Encode.	

7.2.3.2.3.2 DP-V1

Table 212 specifies AL protocol, which is part of DP-master (Class 2) and using features named DP-V1 and options.

NOTE If a device supports DP-V1 features, then it is to specify within the communication feature list of this device type (GSD-file).

Table 212 – CP 3/1, 3/2: AL protocol selection of Clause 4 to 11

Clause	Header	Presence	Constraints
4	FAL syntax description	—	—
4.1	APDU abstract syntax	Partial	See Table 213
4.2	Data types	Partial	Used when applicable
5	Transfer syntax	—	—
5.1	Coding of basic data types	YES	—
5.2	Coding section related to data exchange PDUs	YES	—
5.3	Coding section related to slave diagnosis PDUs	YES	—
5.4	Coding section related to parameterization PDU	YES	—
5.5	Coding section related to configuration PDUs	YES	—
5.6	Coding section related to global control PDUs	YES	—
5.7	Coding section related to clock-value-PDUs	YES	—
5.8	Coding section related to function identification and errors	YES	—
5.9	Coding section related to master diagnosis PDU	YES	—
5.10	Coding section related to Upload/download/act para PDUs	YES	—
5.11	Coding section related to the bus parameter set	YES	—
5.12	Coding section related to the slave parameter set	YES	—
5.13	Coding section related to statistic counters	YES	—
5.14	Coding section related to set slave address PDU	NO	—
5.15	Coding section related to initiate/abort PDUs	NO	—
5.16	Coding section related to read/write/data transport PDUs	YES	—
5.17	Coding section related to load region and function invocation PDUs	YES	—
5.18	Examples of diagnosis-RES-PDUs	YES	—
5.19	Example of Chk_Cfg-REQ-PDU	YES	—
5.20	Examples of Chk_Cfg-REQ-PDUs with DPV1 data types	YES	—
5.21	Example structure of the Data_Unit for Data_Exchange	YES	—
6	FAL protocol state machines	—	—

Clause	Header	Presence	Constraints
6.1	Overall structure	YES	—
6.2	Assignment of state machines to devices	YES	—
6.3	Overview DP-slave	NO	—
6.4	Overview DP-master (class 1)	YES	—
6.5	Overview DP-master (class 2)	NO	—
6.6	Cyclic communication between DP-master (class 1) and DP-slave	YES	—
6.7	Acyclic communication between DP-master (class 2) and DP-master (class 1)	YES	—
6.8	Acyclic communication between DP-master (class 1) and DP-slave	YES	—
6.9	Application relationship monitoring	—	—
6.9.1	Monitoring of the MS0 – AR	—	—
6.9.1.1	General	YES	—
6.9.1.2	Control interval at the DP-slave	NO	—
6.9.1.3	Control intervals at the DP-master (class 1)	NO	—
6.9.2	Monitoring of the MS2 – AR	YES	—
7	AP-Context state machine	NO	—
8	FAL Service Protocol Machines (FSPMs)	—	—
8.1	FSPMS	NO	—
8.2	FSPMM1	Partial	See Table 214
8.3	FSPMM2	NO	—
9	Application Relationship Protocol Machines (ARPMs)	—	—
9.1	MSCY1S	NO	—
9.2	MSAC1S	NO	—
9.3	SSCY1S	NO	—
9.4	MSRM2S	NO	—
9.5	MSAC2S	NO	—
9.6	MSCS1S	NO	—
9.7	MSCY1M	YES	—
9.8	MSAL1M	YES	—
9.9	MSAC1M	YES	—
9.10	MMAC1	YES	—
9.11	MSCS1M	YES	—
9.12	MSAC2M	NO	—
9.13	MMAC2	NO	—
10	DLL Mapping Protocol Machines (DMPMs)	—	—
10.1	DMPMS	NO	—
10.2	DMPMM1	Partial	See Table 215
10.3	DMPMM2	NO	—
11	Parameters for a DP-slave	NO	—

Table 213 – CP 3/1, 3/2: AL protocol selection of APDUs

APDU Name	Decode / Encode
RD_Output-RES-PDU	OD
RD_Output-REQ-PDU	OE
RD_Input-RES-PDU	OD
RD_Input-REQ-PDU	OE
Get_Cfg-REQ-PDU	OE
Get_Cfg-RES-PDU	OD
Diagnosis-RES-PDU	OD
Diagnosis-REQ-PDU	OE
Set_Slave_Add-REQ-PDU	OE
Start_Seq-REQ-PDU	OE
Start_Seq-RES-PDU	OD
Download-REQ-PDU	OE
Download-RES-PDU	OD
Upload-REQ-PDU	OE
Upload-RES-PDU	OD
End_Seq-REQ-PDU	OE
End_Seq-RES-PDU	OD
Act_Para_Brct-REQ-PDU	OE
Act_Param-REQ-PDU	OE
Act_Param-RES-PDU	OD
Initiate-REQ-PDU	OE
Initiate-RES-PDU	OD
Initiate-NRS-PDU	OD
Abort-REQ-PDU	OE
Read-REQ-PDU	OE
Read-RES-PDU	OD
Read-NRS-PDU, Pull-NRS-PDU	OD
Write-REQ-PDU	OE
Write-RES-PDU	OD
Write-, Initiate_Load-, Push-, Terminate_Load-, Start-, Stop-, Resume-, Reset-, Call-, Get_FI_State-NRS-PDU	OD
Idle-REQ-PDU	OE
Idle-RES-PDU	OD
Data_Transport-REQ-PDU	OE
Data_Transport-RES-PDU	OD
Data_Transport-NRS-PDU	OD
Initiate_Load-REQ-PDU	OE
Initiate_Load-RES-PDU	OD
Push-REQ-PDU	OE
Pull-REQ-PDU	OE
Pull-RES-PDU	OD
Terminate_Load-REQ-PDU	OE

APDU Name	Decode / Encode
Start-REQ-PDU	OE
Stop-REQ-PDU	OE
Resume-REQ-PDU	OE
Reset-REQ-PDU	OE
Call-REQ-PDU	OE
Call-RES-PDU	OD
Get_FI_State-REQ-PDU	OE
Get_FI_State-RES-PDU	OD
Push-, Terminate_Load-, Start-, Stop-, Resume-, Reset-RES-PDU	OD
RM-REQ-PDU	OD
Get_Master_Diag-REQ-PDU	OE
Get_Master_Diag-RES-PDU	OD
Start_Seq-REQ-PDU	OE
Start_Seq-RES-PDU	OD
Download-REQ-PDU	OE
Download-RES-PDU	OD
Upload-REQ-PDU	OE
Upload-RES-PDU	OD
End_Seq-REQ-PDU	OE
End_Seq-RES-PDU	OD
Act_Para_Brct-REQ-PDU	OE
Act_Param-REQ-PDU	OD
Act_Param-RES-PDU	OE
NOTE The abbreviations mean: O = Optional; M = Mandatory (default, if not marked as optional); D = Decode; E = Encode.	

Table 214 – CP 3/1, 3/2: AL protocol selection of FSPM services primitives

Service Primitive Name	Usage
MInit.req/cnf	M
Reset.req/cnf	M
Abort.req	M
Read Slave Diag.req/cnf	O
Read Input.req/cnf	O
Read Output.req/cnf	O
Get Cfg.req/cnf	O
Set Slave Add.req/cnf	O
Initiate.req/cnf	O
Read.req/cnf	O
Write.req/cnf	O
Data Transport.req/cnf	O
Get Master Diag.ind/rsp	O
Start Seq.ind/rsp	O
Download.ind/rsp	O
Upload.ind/rsp	O
End Seq.ind/rsp	O
Act Param.ind/rsp	O
Act Para Brct.ind	O
Initiate Load.req/cnf	O
Push Segment.req/cnf	O
Pull Segment.req/cnf	O
Terminate Load.req/cnf	O
Start.req/cnf	O
Stop.req/cnf	O
Resume.req/cnf	O
Reset.req/cnf	O
Call.req/cnf	O
Get FI State.req/cnf	O
Event.ind	O
Reject.ind	O
Abort.ind	O
Fault.ind	M
Closed.ind	M
<p>NOTE The abbreviations mean:</p> <p>O = Optional;</p> <p>M = Mandatory (default, if not marked as optional);</p> <p>D = Decode;</p> <p>E = Encode.</p>	

Table 215 – CP 3/1, 3/2: AL protocol selection of DMPM services primitives

Service name	Usage
MInit DLL.req/cnf	M
Reset.req/cnf	M
Read Slave Diag.req/cnf	O
Read Input.req/cnf	O
Read Output.req/cnf	O
Get Cfg.req/cnf	O
Set Slave Add.req/cnf	O
DATA.req/cnf	O
DATA REPLY.req/cnf	O
NOTE The abbreviations mean: O = Optional; M = Mandatory (default, if not marked as optional); D = Decode; E = Encode.	

7.2.3.2.4 DP-slave**7.2.3.2.4.1 DP-V0**

Table 216 specifies AL protocol, which is part of a DP-slave and using features named DP-V0.

Table 216 – CP 3/1, 3/2: AL protocol selection of Clause 4 to 11

Clause	Header	Presence	Constraints
4	FAL syntax description	—	—
4.1	APDU abstract syntax	Partial	See Table 217
4.2	Data types	Partial	Used when applicable
5	Transfer syntax	—	—
5.1	Coding of basic data types	YES	—
5.2	Coding section related to data exchange PDUs	YES	—
5.3	Coding section related to slave diagnosis PDUs	YES	—
5.4	Coding section related to parameterization PDU	YES	—
5.5	Coding section related to configuration PDUs	YES	—
5.6	Coding section related to global control PDUs	YES	—
5.7	Coding section related to clock-value-PDUs	NO	—
5.8	Coding section related to function identification and errors	NO	—
5.9	Coding section related to master diagnosis PDU	NO	—
5.10	Coding section related to Upload/download/act para PDUs	NO	—
5.11	Coding section related to the bus parameter set	NO	—

Clause	Header	Presence	Constraints
5.12	Coding section related to the slave parameter set	NO	—
5.13	Coding section related to statistic counters	NO	—
5.14	Coding section related to set slave address PDU	NO	—
5.15	Coding section related to initiate/abort PDUs	NO	—
5.16	Coding section related to read/write/data transport PDUs	NO	—
5.17	Coding section related to load region and function invocation PDUs	NO	—
5.18	Examples of diagnosis-RES-PDUs	NO	—
5.19	Example of Chk_Cfg-REQ-PDU	NO	—
5.20	Examples of Chk_Cfg-REQ-PDUs with DPV1 data types	NO	—
5.21	Example structure of the Data_Unit for Data_Exchange	NO	—
6	FAL protocol state machines	—	—
6.1	Overall structure	—	—
6.1.1	Fieldbus Service Protocol Machines (FSPM)	YES	—
6.1.2	Master to Slave cyclic (MS0)	NO	—
6.1.3	Master (class 1) to Slave acyclic (MS1)	NO	—
6.1.4	Master (class 2) to Slave acyclic (MS2)	NO	—
6.1.5	Master to Slave clock synchronization (MS3)	NO	—
6.1.6	Master Master acyclic (MM1/MM2)	NO	—
6.1.7	DLL Mapping Protocol Machines (DMPM)	NO	—
6.2	Assignment of state machines to devices	YES	—
6.3	Overview DP-slave	NO	—
6.4	Overview DP-master (class 1)	YES	—
6.5	Overview DP-master (class 2)	NO	—
6.6	Cyclic communication between DP-master (class 1) and DP-slave	YES	—
6.7	Acyclic communication between DP-master (class 2) and DP-master (class 1)	NO	—
6.8	Acyclic communication between DP-master (class 1) and DP-slave	NO	—
6.9	Application relationship monitoring	—	—
6.9.1	Monitoring of the MS0 – AR	—	—
6.9.1.1	General	YES	—
6.9.1.2	Control interval at the DP-slave	YES	—
6.9.1.3	Control intervals at the DP-master (class 1)	NO	—
6.9.2	Monitoring of the MS2 – AR	NO	—
7	AP-Context state machine	NO	—
8	FAL Service Protocol Machines (FSPMs)	—	—
8.1	FSPMS	Partial	See Table 218
8.2	FSPMM1	NO	—
8.3	FSPMM2	NO	—

Clause	Header	Presence	Constraints
9	Application Relationship Protocol Machines (ARPMs)	—	—
9.1	MSCY1S	YES	—
9.2	MSAC1S	NO	—
9.3	SSCY1S	NO	—
9.4	MSRM2S	NO	—
9.5	MSAC2S	NO	—
9.6	MSCS1S	NO	—
9.7	MSCY1M	NO	—
9.8	MSAL1M	NO	—
9.9	MSAC1M	NO	—
9.10	MMAC1	NO	—
9.11	MSCS1M	NO	—
9.12	MSAC2M	NO	—
9.13	MMAC2	NO	—
10	DLL Mapping Protocol Machines (DMPMs)	—	—
10.1	DMPMS	Partial	See Table 219
10.2	DMPMM1	NO	—
10.3	DMPMM2	NO	—
11	Parameters for a DP-slave	YES	—

Table 217 – CP 3/1, 3/2: AL protocol selection of APDU selection

APDU Name	Decode / Encode
DataExchange-REQ-PDU	D
DataExchange-RES-PDU	E
Chk_Cfg-REQ-PDU	D
Set_Prm-REQ-PDU	D
Diagnosis-RES-PDU	E
Global_Control-REQ-PDU	D
RD_Output-RES-PDU	OE
RD_Input-RES-PDU	OE
Get_Cfg-REQ-PDU	OE
Set_Slave_Add-REQ-PDU	OD
NOTE The abbreviations mean: O = Optional; M = Mandatory (default, if not marked as optional); D = Decode; E = Encode.	

Table 218 – CP 3/1, 3/2: AL protocol selection of FSPM services primitives

Service name	Usage
DLL Init.req/cnf	M
Init MS0.req/cnf	M
Reset.req/cnf	M
Abort.req	M
CheckUserPrmResult.req/cnf	M
Check Cfg Result.req/cnf	M
Set Cfg.req/cnf	M
Set Slave Diag.req/cnf	M
Set Input.req/cnf	M
Get Output.req/cnf	M
Started.ind	M
Stopped.ind	M
Abort.ind	M
Fault.ind	M
Set Slave Add.ind	O
Check Cfg.ind	M
CheckUserPrm.ind	M
New Output.ind	M
Global Control.ind	M
<p>NOTE The abbreviations mean:</p> <p>O = Optional;</p> <p>M = Mandatory (default, if not marked as optional);</p> <p>D = Decode;</p> <p>E = Encode.</p>	

Table 219 – CP 3/1, 3/2: AL protocol selection of DMPM services primitives

Service Primitive Name	Usage
SInit DLL.req/cnf	M
Reset.req/cnf	M
Fault.ind	M
Slave Init.req/cnf	M
Enter.req	M
Leave.req	M
Slave Deact.req/cnf	M
Set minTsdr.req	M
Slave Diag Upd.req	M
Data Exchange Upd.req	M
RD Outp Upd.req	M
RD Inp Upd.req	M
Set Slave Add.ind	O
Slave Diag.ind	M
Set Prm.ind	M
Chk Cfg.ind	M
Data Exchange.ind	M
Global Control.ind	M
NOTE The abbreviations mean: O = Optional; M = Mandatory (default, if not marked as optional); D = Decode; E = Encode.	

7.2.3.2.4.2 DP-V1

Table 220 specifies AL protocol, which is part of a DP-slave and using features named DP-V1 and options.

NOTE If a device supports DP-V1 features, then it is to specify within the communication feature list of this device type (GSD-file).

Table 220 – CP 3/1, 3/2: AL protocol selection of Clause 4 to 11

Clause	Header	Presence	Constraints
4	FAL syntax description	—	—
4.1	APDU abstract syntax	Partial	See Table 221
4.2	Data types	Partial	Used when applicable
5	Transfer syntax	—	—
5.1	Coding of basic data types	YES	—
5.2	Coding section related to data exchange PDUs	YES	—
5.3	Coding section related to slave diagnosis PDUs	YES	—
5.4	Coding section related to parameterization PDU	YES	—
5.5	Coding section related to configuration PDUs	YES	—
5.6	Coding section related to global control PDUs	YES	—
5.7	Coding section related to clock-value-PDUs	YES	—
5.8	Coding section related to function identification and errors	YES	—
5.9	Coding section related to master diagnosis PDU	NO	—
5.10	Coding section related to Upload/download/act para PDUs	NO	—
5.11	Coding section related to the bus parameter set	NO	—
5.12	Coding section related to the slave parameter set	NO	—
5.13	Coding section related to statistic counters	NO	—
5.14	Coding section related to set slave address PDU	NO	—
5.15	Coding section related to initiate/abort PDUs	YES	—
5.16	Coding section related to read/write/data transport PDUs	YES	—
5.17	Coding section related to load region and function invocation PDUs	YES	—
5.18	Examples of diagnosis-RES-PDUs	NO	—
5.19	Example of Chk_Cfg-REQ-PDU	NO	—
5.20	Examples of Chk_Cfg-REQ-PDUs with DPV1 data types	NO	—
5.21	Example structure of the Data_Unit for Data_Exchange	NO	—
6	FAL protocol state machines	—	—
6.1	Overall structure	YES	—
6.2	Assignment of state machines to devices	YES	—
6.3	Overview DP-slave	YES	—
6.4	Overview DP-master (class 1)	NO	—
6.5	Overview DP-master (class 2)	NO	—
6.6	Cyclic communication between DP-master (class 1) and DP-slave	YES	—
6.7	Acyclic communication between DP-master (class 2) and DP-master (class 1)	NO	—
6.8	Acyclic communication between DP-master (class 1) and DP-slave	YES	—
6.9	Application relationship monitoring	—	—
6.9.1	Monitoring of the MS0 – AR	—	—
6.9.1.1	General	YES	—

Clause	Header	Presence	Constraints
6.9.1.2	Control interval at the DP-slave	YES	—
6.9.1.3	Control intervals at the DP-master (class 1)	NO	—
6.9.2	Monitoring of the MS2 – AR	NO	—
7	AP-Context state machine	NO	—
8	FAL Service Protocol Machines (FSPMs)	—	—
8.1	FSPMS	Partial	See Table 222
8.2	FSPMM1	NO	—
8.3	FSPMM2	NO	—
9	Application Relationship Protocol Machines (ARPMs)	—	—
9.1	MSCY1S	YES	—
9.2	MSAC1S	YES	—
9.3	SSCY1S	YES	—
9.4	MSRM2S	YES	—
9.5	MSAC2S	YES	—
9.6	MSCS1S	YES	—
9.7	MSCY1M	NO	—
9.8	MSAL1M	NO	—
9.9	MSAC1M	NO	—
9.10	MMAC1	NO	—
9.11	MSCS1M	NO	—
9.12	MSAC2M	NO	—
9.13	MMAC2	NO	—
10	DLL Mapping Protocol Machines (DMPMs)	—	—
10.1	DMPMS	Partial	See Table 223
10.2	DMPMM1	NO	—
10.3	DMPMM2	NO	—
11	Parameters for a DP-slave	YES	—

Table 221 – CP 3/1, 3/2: AL protocol selection of APDUs

APDU Name	Decode/Encode
DataExchange-REQ-PDU	D
DataExchange-RES-PDU	E
Chk_Cfg-REQ-PDU	D
Set_Prm-REQ-PDU	D
Set_Ext_Prm-REQ-PDU	OD
RD_Output-RES-PDU	OE
RD_Input-RES-PDU	OE
Get_Cfg-REQ-PDU	OE
Set_Slave_Add-REQ-PDU	OD
Diagnosis-RES-PDU	E
Global_Control-REQ-PDU	D
Clock-Value-PDU	OE
Initiate-REQ-PDU	OD
Initiate-RES-PDU	OE
Initiate-NRS-PDU	OE
Abort-REQ-PDU	OD
Read-REQ-PDU	OD
Read-RES-PDU	OE
Read-NRS-PDU, Pull-NRS-PDU	OE
Write-REQ-PDU	OD
Write-RES-PDU	OE
Write-, Initiate_Load-, Push-, Terminate_Load, Start-, Stop-, Resume-, Reset-, Call-, Get_FI_State-NRS-PDU	OE
Alarm_Ack-REQ-PDU	OD
Alarm_Ack-RES-PDU	OE
Alarm_Ack-NRS-PDU	OE
Idle-REQ-PDU	OD
Idle-RES-PDU	OE
Data_Transport-REQ-PDU	OD
Data_Transport-RES-PDU	OE
Data_Transport-NRS-PDU	OE
Initiate_Load-REQ-PDU	OD
Initiate_Load-RES-PDU	OE
Push-REQ-PDU	OD
Pull-REQ-PDU	OD
Pull-RES-PDU	OE
Terminate_Load-REQ-PDU	OD
Start-REQ-PDU	OD
Stop-REQ-PDU	OD
Resume-REQ-PDU	OD
Reset-REQ-PDU	OD
Call-REQ-PDU	OD

APDU Name	Decode/Encode
Call-RES-PDU	OE
Get_FI_State-REQ-PDU	OD
Get_FI_State-RES-PDU	OE
Push-, Terminate_Load-, Start-, Stop-, Resume-, Reset-RES-PDU	OE
RM-REQ-PDU	OE
NOTE The abbreviations mean: O = Optional; M = Mandatory (default, if not marked as optional); D = Decode; E = Encode.	

Table 222 – CP 3/1, 3/2: AL protocol selection of FSPM services primitives

Service name	Usage
DLL Init.req/cnf	M
Init MS0.req/cnf	M
Reset.req/cnf	M
Abort.req	M
Reset.req/cnf	M
Abort.req	M
CheckUserPrmResult.req/cnf	M
CheckExtUserPrmResult.req/cnf	M
Check Cfg Result.req/cnf	M
Set Cfg.req/cnf	M
Set Slave Diag.req/cnf	M
Set Input.req/cnf	M
Get Output.req/cnf	M
Started.ind	M
Stopped.ind	M
Abort.ind	M
Fault.ind	M
Set Slave Add.ind	O
Check Cfg.ind	M
CheckUserPrm.ind	M
CheckExtUserPrm.ind	M
New Output.ind	M
Global Control.ind	M
Initiate.ind/rsp	O
Read.ind/rsp	O
Write.ind/rsp	O
Data Transport.ind/rsp	O
Alarm Ack.ind/rsp	O
LR Initiate Load.ind/rsp	O
LR Push Segment.ind/rsp	O
LR Pull Segment.ind/rsp	O

Service name	Usage
LR Terminate Load.ind/rsp	O
FI Start.ind/rsp	O
FI Stop.ind/rsp	O
FI Resume.ind/rsp	O
FI Reset.ind/rsp	O
FI Call.ind/rsp	O
Get FI State.ind/rsp	O
SYNCH_Event.ind	O
Set Time.ind	O
SyncIntervalViolation.ind	O
New Publisher Data.ind	O
Publisher Active.ind	O
GetPublisherData.req/cnf	O
Start Subscriber.req/cnf	O
Stop Subscriber.req/cnf	O
Load CRL DXB-Linktable Entries.req/cnf	O
Set ARL Isochron Mode.req/cnf	O
Alarm Notification.req/cnf	O
Application Ready.req	O
<p>NOTE The abbreviations mean:</p> <p>O = Optional;</p> <p>M = Mandatory (default, if not marked as optional);</p> <p>D = Decode;</p> <p>E = Encode.</p>	

Table 223 – CP 3/1, 3/2: AL protocol selection of DMPM services primitives

Service Primitive Name	Usage
SInit DLL.req/cnf	M
Reset.req/cnf	M
Fault.ind	M
Slave Init.req/cnf	M
Enter.req	M
Leave.req	M
Slave Deact.req/cnf	M
Set minTsdr.req	M
Slave Diag Upd.req	M
Data Exchange Upd.req	M
RD Outp Upd.req	M
RD Inp Upd.req	M
Set Slave Add.ind	O
Slave Diag.ind	M
Set Prm.ind	M
Set Ext Prm.ind	O
Chk Cfg.ind	M
Data Exchange.ind	M
Global Control.ind	M
RSAP ACTIVATE.req/cnf	O
SAP DEACTIVATE.req/cnf	O
REPLY UPDATE.req/cnf	O
DATA REPLY.ind	O
DX Broadcast.ind	O
DX Entered.ind	O
CS CLOCK VALUE.ind	O
NOTE The abbreviations mean: O = Optional; M = Mandatory (default, if not marked as optional); D = Decode; E = Encode.	

7.2.3.2.5 Options

7.2.3.2.5.1 Process data

Process data functionality (acyclic R/W-services) is described in IEC 61158-5-3, 6.2.1 Process Data ASE. It is optional.

This option may be used for DP-V1 – DP-master (Class 1), (see 7.2.3.1.2.2), DP-V1 – DP-master (Class 2), (see 7.2.3.1.3.2) and DP-V1 – DP-slaves (see 7.2.3.1.4.2).

7.2.3.2.5.2 Alarm

Alarm functionality is described in IEC 61158-5-3, 6.2.4 Alarm ASE. It is optional.

This option may be used for DP-V1 – DP-master (Class 1), (see 7.2.3.1.2.2), and DP-V1 – DP-slaves (see 7.2.3.1.4.2).

7.2.3.2.5.3 Fail safe

Fail Safe functionality is described in IEC 61158-5-3, 6.2.10.4.2.2.

This is optional for DP-V0 – DP-master (Class 1), (see 7.2.3.1.2.1) and DP-V1 / DP-V0 – DP-slaves (see 7.2.3.1.4.2 / 7.2.3.1.4.1).

This functionality shall be supported by DP-V1 – DP-master (Class 1), (see 7.2.3.1.2.2).

7.2.3.2.5.4 Synch / freeze

Synch / freeze functionality is described in IEC 61158-5-3, 6.2.2, I/O Data ASE.

This option may be used for DP-V1 / DP-V0 – DP-master (Class 1), (see 7.2.3.1.2.2 / 7.2.3.1.2.1), and DP-V1 / DP-V0 – DP-slaves (see 7.2.3.1.4.2 / 7.2.3.1.4.1). It is specified for DP-V1 / DP-V0 – DP-master (Class 1) in IEC 61158-5-3, 6.2.2.3.9, and for DP-V1 / DP-V0 – DP-slaves in IEC 61158-5-3, 6.2.10.3.1.2.

7.2.3.2.5.5 Isochronous mode

Isochronous mode functionality is described in IEC 61158-5-3, 6.2.2 I/O Data ASE especially see IEC 61158-5-3, 6.2.2.4.2.

This option may be used for DP-V1 – DP-master (Class 1), (see 7.2.3.1.2.2) and DP-V1 – DP-slaves (see 7.2.3.1.4.2).

7.2.3.2.5.6 Publisher/Subscriber

Publisher/Subscriber functionality is described in IEC 61158-5-3, 6.2.2 I/O Data ASE.

The Publisher option may be used for DP-V1 / DP-V0 – DP-slaves (see 7.2.3.1.4.2 / 7.2.3.1.4.1).

The Subscriber option may be used only for DP-V1 – DP-slaves (see 7.2.3.1.4.2).

This option may be used for DP-V1 – DP-master (Class 1), (see 7.2.3.1.2.2).

7.2.3.2.5.7 Extended Parameterization (ExtPrm)

Extended Parameterization (ExtPrm) functionality is described in IEC 61158-5-3, 6.2.5, context ASE especially see IEC 61158-5-3, 6.2.5.2.2 and for master (Class 1) see IEC 61158-5-3, 6.2.6.2.2 with Ext User Prm Data and for master (Class 2) see IEC 61158-5-3, 6.2.6.3.3.

This option may be used for DP-V1 – DP-master (Class 1), (see 7.2.3.1.2.2), DP-V1 – DP-master (Class 2), (see 7.2.3.1.3.2) and DP-V1 – DP-slaves (see 7.2.3.1.4.2).

7.2.3.2.5.8 Load region

Load region functionality is described in IEC 61158-5-3, 6.2.7 Load region ASE. It is optional.

This option may be used for DP-V1 – DP-master (Class 1), (see 7.2.3.1.2.2), DP-V1 – DP-master (Class 2), (see 7.2.3.1.3.2), and DP-V1 – DP-slaves (see 7.2.3.1.4.2).

7.2.3.2.5.9 Function invocation

Function invocation functionality is described in IEC 61158-5-3, 6.2.8 Function invocation ASE. It is optional.

This option may be used for DP-V1 – DP-master (Class 1), (see 7.2.3.1.2.2), DP-V1 – DP-master (Class 2), (see 7.2.3.1.3.2) and DP-V1 – DP-slaves (see 7.2.3.1.4.2).

7.2.3.2.5.10 Clock synchronization

Clock synchronization functionality is described in IEC 61158-5-3, 6.2.9 Time ASE. It is optional.

This option may be used for DP-V1 – DP-master (Class 1), (see 7.2.3.1.2.2), DP-V1 – DP-master (Class 2), (see 7.2.3.1.3.2) and DP-V1 – DP-slaves (see 7.2.3.1.4.2).

7.2.3.2.5.11 Redundancy

Redundancy functionality is described in IEC 61158-5-3, 6.1.4. It is optional.

This option may be used for DP-V1 – DP-master (Class 1), (see 7.2.3.1.2.2), DP-V1 – DP-slaves (see 7.2.3.1.4.2).

7.3 Profile 3/2 (PROFIBUS PA)

7.3.1 Physical layer

7.3.1.1 PhL selection

Table 224 specifies the selection of the IEC 61158-2 for devices of all types of this profile. Subclause 7.2.1.2 specifies additional considerations.

Table 224 – CP 3/2: PhL selection

Clause	Header	Presence	Constraints
1	Scope	YES	—
2	Normative references	Partial	Relevant references only
3	Terms and definitions	Partial	See Table 118
4	Symbols and abbreviations	Partial	See Table 119
5	DLL – PhL interface	—	—
5.1	General	YES	—
5.2 – 5.3	—	NO	—
5.4	Type 3: Required services	—	—
5.4.1	Synchronous Transmission	YES	—
5.4.2	Asynchronous Transmission	NO	—
5.5 – 5.7	—	NO	—
6	Systems management – PhL interface	—	—
6.1	General	YES	—
6.2	Type 1: Systems management – PhL interface	NO	—
6.3	Type 3: Systems management – PhL interface	—	—
6.3.1	Synchronous Transmission	YES	—
6.3.2	Asynchronous Transmission	NO	—
6.4 – 6.8	—	NO	—
7	DCE Independent sublayer (DIS)	—	—
7.1	General	YES	—
7.2	Type 1: DIS	YES	—
7.3	Type 3: DIS	—	—
7.3.1	Synchronous transmission	YES	—
7.3.2	Asynchronous transmission	NO	—
7.4 – 7.6	—	NO	—
8	DTE – DCE interface and MIS-specific functions	—	—
8.1	General	YES	—
8.2	Type 1: DTE – DCE interface	YES	—
8.3	Type 3: DTE – DCE interface	—	—
8.3.1	Synchronous transmission	YES	—
8.3.2	Asynchronous transmission	NO	—
8.4 – 8.5	—	NO	—
9	Medium dependent sublayer (MDS)	—	—
9.1	General	YES	—
9.2	Type 1: MDS: Wire and optical media	YES	—
9.3 – 9.4	—	NO	—
9.5	Type 3: MDS: Wire and optical media	—	—
9.5.1	Synchronous Transmission	YES	—
9.5.2	Asynchronous Transmission	NO	—
9.6 – 9.11	—	—	—
10	MDS – MAU interface	—	—
10.1	General	YES	—
10.2	Type 1: MDS – MAU interface: wire and optical media	YES	—

Clause	Header	Presence	Constraints
10.3 – 10.4	—	NO	—
10.5	Type 3: MDS – MAU interface: Wire and optical media	—	—
10.5.1	Synchronous Transmission	YES	—
10.5.3	Asynchronous Transmission	NO	—
10.6 – 10.8	—	NO	—
11	Type 1 and 7: Medium Attachment Unit: voltage mode, linear-bus-topology 150 Ω twisted-pair wire medium	Partial	See Clause 12 and Clause 21 of IEC 61158-2
12	Type 1 and 3 synchronous Transmission: Medium Attachment Unit: 31,25 kbit/s, voltage-mode with low-power option, bus- and tree-topology, 100 Ω wire medium	Partial	Only for MBP-LP, see 7.3.1.2
13 – 20	—	NO	—
21	Type 3: Medium Attachment Unit: Synchronous Transmission, 31,25 kbit/s, voltage mode, wire medium	YES	Only for MBP and MBP-IS, see 7.3.1.3
Next clauses	—	NO	—
Annex A	(normative) Type 1: Connector specification	—	—
A.1	Internal connector for wire medium	YES	The connector is optional
A.2	External connectors for wire medium	NO	See Annex H
A.3	External connectors for optical medium	NO	—
Annex B	Type 1: Cable specifications and trunk and spur lengths for the 31,25 kbit/s voltage-mode MAU	YES	—
Annex C– H	—	NO	—
Annex I	(normative) Type 3: Connector specification	—	—
I.1	Connector for synchronous transmission	YES	For CP 3/2 of Table 116
I.2	Connector for asynchronous transmission	NO	—
I.3	Connector for fiber optic cable	NO	—
Annex J	(normative) Type 3: Redundancy of PhL and medium	YES	Redundancy is optional
Next annexes	—	NO	—

7.3.1.2 MAU selection for MBP-LP

Table 225 specifies the constraints for the optional MAU of CP 3/2 named MBP-LP, see Table 116.

Table 225 – CP 3/2: PhL selection of Clause 12 for devices and their MAUs

Clause	Header	Presence	Constraints
12.1	General	YES	—
12.2	Transmitted bit rate	YES	—
12.3	Network specifications	YES	—
12.4	MAU transmit circuit specification	YES	—
12.5	MAU receive circuit specification	Partial	—
12.5.1	Summary	YES	—
12.5.2	Input impedance	YES	—
12.5.3	Receiver sensitivity and noise rejection	YES	—
12.5.4	Receiver bit cell jitter	YES	—
12.5.5	Interference susceptibility and error rates	NO	NOTE In Europe the CE guidelines are valid for EMC
12.6	Jabber inhibit	YES	—
12.7	Power distribution	—	—
12.7.1	General	YES	—
12.7.2	Supply voltage	YES	—
12.7.3	Powered via signal conductors	YES	—
12.7.4	Power supply impedance	NO	—
12.7.5	Powered separately from signal conductors	NO	—
12.7.6	Electrical isolation	YES	—
12.8	Medium specifications	—	—
12.8.1	Connector	YES	—
12.8.2	Standard test cable	YES	For IS applications the FISCO rules (IEC 60079-11 and IEC 60079-25) are always applied.
12.8.3	Coupler	YES	—
12.8.4	Splices	YES	—
12.8.5	Terminator	YES	—
12.8.6	Shielding rules	YES	—
12.8.7	Grounding (earthing) rules	YES	It is recommended to ground the shield of the fieldbus cable as often as possible. This is usually the best practice to improve EMC.
12.8.8	Color coding of cables	YES	—
12.9	Intrinsic safety	YES	See Table 226 for the IS parameters
12.10	Galvanic isolators	YES	—

Table 226 – CP 3/2: PhL selection of recommended IS parameters

Parameter	Recommended values	
	Linear barrier model	FISCO model
Device approval voltage	24 V minimum	17,5 V minimum
Device approval current	250 mA minimum	380 mA minimum
Device input power	1,2 W minimum	5,32 W minimum
Device residual capacitance	≤ 5 nF	≤ 5 nF
Device residual inductance	≤ 20 μH	≤ 10 μH
Leakage current	(not specified)	≤ 50 μA
IS classification	Ex ia, IIC (gas groups A & B), T4	Ex ia, IIC (gas groups A, B, C, D), T4 Ex ib, IIC (gas groups A, B, C, D), T4
Governing requirements	See IEC 60079-11	See IEC 60079-11 and IEC 60079-25

7.3.1.3 MAU selection for MBP and MBP-IS

Table 227 specifies the constraints for the optional MAU CP 3/2 named MBP and MBP-IS, see Table 116. For MBP-IS apply IEC 60079-11 and IEC 60079-25.

Table 227 – CP 3/2: PhL selection of Clause 21 for devices and their MAUs

Clause	Header	Presence	Constraints
21.1	General	YES	—
21.2	Transmitted bit rate	YES	—
21.3	Network specifications	YES	—
21.4	Transmit circuit specification for 31,25 kbit/s voltage-mode MAU	YES	—
21.5	Receive circuit specification for 31,25 kbit/s voltage-mode MAU	YES	—
21.6	Jabber inhibit	YES	—
21.7	Power distribution	—	—
21.7.1	General	YES	—
21.7.2	Supply voltage	YES	—
21.7.3	Powered via signal conductors	YES	—
21.7.4	Electrical isolation	YES	—
21.8	Medium specifications	—	—
21.8.1	Connector	YES	—
21.8.2	Standard test cable	YES	For IS applications the FISCO rules (IEC 60079-11 and IEC 60079-25) are always applied.
21.8.3	Coupler	YES	—
21.8.4	Splices	YES	—
21.8.5	Terminator	YES	—
21.8.6	Shielding rules	YES	—
21.8.7	Grounding rules	YES	It is recommended to ground the shield of the fieldbus cable as often as possible. This is usually the best practice to improve EMC.
21.8.8	Cable colors	YES	—
21.9	Intrinsic safety	NO	See Table 226 for the IS parameters
21.10	Galvanic isolators	YES	—
21.11	Coupling Elements	NO	—
21.12	Power supply	YES	—

7.3.1.4 Electrical safety

Devices shall comply with the legal requirements of that country where they are deployed (for example, as indicated by the CE mark). The measures for protection against electrical shocks (i.e. electrical safety) within industrial applications shall be based on the IEC 61010 series or IEC 61131-2 depending on device type specified therein.”

7.3.2 Data-link layer

7.3.2.1 DLL service selection

The CP 3/2 uses the same DLL service selection as CP 3/1, which is specified in 7.2.2.1.

7.3.2.2 DLL protocol selection

7.3.2.2.1 General selection

Table 228 specifies the selection of the Data-link services within IEC 61158-4-3.

Table 228 – CP 3/2: General DLL protocol selection

Clause	Header	Presence	Constraints
1	Scope	YES	—
2	Normative references	Partial	Relevant references only
3	Terms, definitions, symbols and abbreviations	—	—
3.1	Reference model terms and definitions	Partial	Used when applicable
3.2	Service convention terms and definitions	Partial	Used when applicable
3.3	Common terms and definitions	Partial	Used when applicable
3.4	Additional Type 3 definitions	YES	—
3.5	Common symbols and abbreviations	Partial	Relevant symbols and abbreviations only
3.6	Type 3 symbols and abbreviations	YES	—
4	Common DL protocol elements	Partial	See Table 229
5	Overview of the DL-protocol	Partial	See Table 230 and 7.3.2.2.2, 7.3.2.2.3, and 7.3.2.2.4
6	General structure and encoding of DLPDUs, and related elements of procedure	Partial	See Table 231 and 7.3.2.2.2, 7.3.2.2.3, and 7.3.2.2.4
7	DLPDU-specific structure, encoding and elements of procedure	Partial	See Table 232 and 7.3.2.2.2, 7.3.2.2.3, and 7.3.2.2.4
8	Other DLE elements of procedure	Partial	See 7.3.2.2.2, 7.3.2.2.3, and 7.3.2.2.4
Annex A	DL-protocol state machines	YES	—
Annex B	Type 3 (synchronous): exemplary FCS implementations	YES	—
Annex C	Type 3: Exemplary token procedure and message transfer periods	YES	—

Table 229 – CP 3/2: DLL protocol selection of Clause 4

Clause	Header	Presence	Constraints
4.1	Frame check sequence	—	—
4.1.1	At the sending DLE	YES	—
4.1.2	At the receiving DLE	YES	—
4.1.3	Modification within bridges	NO	—

Table 230 – CP 3/2: DLL protocol selection of Clause 5

Clause	Header	Presence	Constraints
5.1	General	YES	—
5.2	Overview of the medium access control and transmission protocol	YES	—
5.3	Transmission mode and DL entity	YES	—
5.4	Service assumed from the PhL	—	—
5.4.1	Asynchronous transmission	NO	—
5.4.2	Synchronous transmission	YES	—
5.5	Operational elements	—	—
5.5.1	Overview	YES	—
5.5.2	Bit time t_{BIT}	YES	—
5.5.3	Asynchronous transmission	NO	—
5.5.4	Synchronous transmission	YES	—
5.5.5	Timers and counters	—	—
5.5.5.1	Asynchronous transmission	NO	—
5.5.5.2	Synchronous transmission	YES	—
5.6	Cycle and system reaction times	—	—
5.6.1	Asynchronous transmission	NO	—
5.6.2	Synchronous transmission	YES	—

Table 231 – CP 3/2: DLL protocol selection of Clause 6

Clause	Header	Presence	Constraints
6.1	DLPDU granularity	—	—
6.1.1	Asynchronous transmission – UART character	NO	—
6.1.2	Synchronous transmission	YES	—
6.2	Length octet (LE, LEr)	YES	—
6.3	Address octet	YES	—
6.4	Control octet (FC)	YES	—
6.5	DLPDU content error detection	—	—
6.5.1	Asynchronous transmission – frame checksum (FCS)	NO	—
6.5.2	Synchronous transmission -frame check sequence (FCS)	YES	—
6.6	DATA_UNIT	YES	—
6.7	Error control procedures	—	—
6.7.1	Asynchronous transmission	NO	—
6.7.2	Synchronous transmission	YES	—

Table 232 – CP 3/2: DLL protocol selection of Clause 7

Clause	Header	Presence	Constraints
7.1	DLPDUs of fixed length with no data field	—	—
7.1.1	Asynchronous transmission	NO	—
7.1.2	Synchronous transmission	YES	—
7.2	DLPDUs of fixed length with data field	—	—
7.2.1	Asynchronous transmission	NO	—
7.2.2	Synchronous transmission	YES	—
7.3	DLPDUs with variable data field length	—	—
7.3.1	Asynchronous transmission	NO	—
7.3.2	Synchronous transmission	YES	—
7.4	Token DLPDU	—	—
7.4.1	Asynchronous transmission	NO	—
7.4.2	Synchronous transmission	YES	—
7.5	ASP DLPDU	Partial	See Table 235, Table 238, Table 241, Table 244, and Table 247
7.6	SYNCH DLPDU	Partial	See Table 235, Table 238, Table 241, Table 244, and Table 247
7.7	Time Event (TE) DLPDU	Partial	See Table 235, Table 238, Table 241, Table 244, and Table 247
7.8	Clock Value (CV) DLPDU	Partial	See Table 235, Table 238, Table 241, Table 244, and Table 247
7.9	Transmission procedures	—	—
7.9.1	Asynchronous transmission	NO	—
7.9.2	Synchronous transmission	YES	—

7.3.2.2.2 Selection for DP-master (class 1)

7.3.2.2.2.1 DP-V0 master (class 1)

Table 233 specifies the CP 3/2 selection of the time parameters of the Data-link protocol, which are part of DP-master (class 1) and using features named DP-V0.

Table 233 – CP 3/2: Time variable selection for DP-V0 master (class 1)

Clause	Variable name	Usage	Constraint
5.5.3.1	Synchronization time (T_{SYN})	M	—
5.5.3.2	Synchronization interval time (T_{SYNI})	M	—
5.5.3.3	Station delay time (T_{SDx})	M	—
5.5.3.4	Quiet time (T_{QUI})	M	—
5.5.3.5	Ready time (T_{RDY})	M	—
5.5.3.6	Safety margin (T_{SM})	M	—
5.5.3.7	Idle time (T_{IDx})	M	—
5.5.3.8	Transmission delay time (T_{TD})	M	—
5.5.3.9	Slot time (T_{SL})	M	—
5.5.3.10	Time-out T_{TO}	M	—
5.5.3.11	GAP update time (T_{GUD})	M	—
5.5.3.12	Isochronous Mode	—	—
5.5.3.13	Send delay time (T_{SD})	—	—
5.5.3.14	Receive delay time (T_{RD})	—	—
5.5.3.15	Clock synchronization interval time (T_{CSI})	—	—

Table 234 specifies the CP 3/2 selection of the timers and counters of the Data-link protocol, which are part of DP-master (class 1) and using features named DP-V0.

Table 234 – CP 3/2: Timer and counter selection for DP-V0 master (class 1)

Clause	Timer or counter	Usage	Constraint
5.5.5.1.1	token-rotation-timer	M	—
5.5.5.1.1	idle-timer	M	—
5.5.5.1.1	slot-timer	M	—
5.5.5.1.1	time-out-timer	M	—
5.5.5.1.1	syn-interval-timer	M	—
5.5.5.1.1	GAP-update-timer	M	—
5.5.5.1.1	isochronous-cycle-timer	—	—
5.5.5.1.1	passive-spare-timer	—	—
5.5.5.1.1	send-delay-timer	—	—
5.5.5.1.1	receive-delay-timer	—	—
5.5.5.1.2	DLPDU_sent_count	O	—
5.5.5.1.2	Retry_count	O	—
5.5.5.1.2	DLPDU_sent_count_sr	O	—
5.5.5.1.2	Error_count	O	—
5.5.5.1.2	SD_count	O	—
5.5.5.1.2	SD_error_count	O	—

Table 235 specifies the CP 3/2 selection of the types of DLPDUs of the Data-link protocol, which are part of DP-master (class 1) and using features named DP-V0.

Table 235 – CP 3/2: DLPDU selection for DP-V0 master (class 1)

Clause	DLPDU	Usage	Constraint
7.1	DLPDUs of fixed length with no data field	M	—
7.2	DLPDUs of fixed length with data field	M	Option for sending
7.3	DLPDUs with variable data field length	M	—
7.4	Token DLPDU	M	—
7.5	ASP DLPDU	—	—
7.6	SYNCH DLPDU	—	—
7.7	Time Event (TE) DLPDU	—	—
7.8	Clock Value (CV) DLPDU	—	—

For Clause 8 of IEC 61158-4-3 the following constraints apply:

- a) The CP 3/2 selection of states of the media access, which are part of DP-master (class 1) and using features named DP-V0, are the same as specified for CP 3/1 DP-V0-master (class 1) in Table 138.
- b) The CP 3/2 selection of the clock synchronization protocol of the DL-entity of the Data-link protocol, which are part of DP-master (class 1) and using features named DP-V0, is empty.

7.3.2.2.2.2 DP-V1 master (class 1)

Table 236 specifies the CP 3/2 selection of the time parameters of the Data-link protocol, which are part of DP-master (class 1) and using features named DP-V1 and options.

Table 236 – CP 3/2: Time variable selection for DP-V1 master (class 1)

Clause	Variable name	Usage	Constraint
5.5.3.1	Synchronization time (T_{SYN})	M	—
5.5.3.2	Synchronization interval time (T_{SYNI})	M	—
5.5.3.3	Station delay time (T_{SDx})	M	—
5.5.3.4	Quiet time (T_{QUI})	M	—
5.5.3.5	Ready time (T_{RDY})	M	—
5.5.3.6	Safety margin (T_{SM})	M	—
5.5.3.7	Idle time (T_{IDx})	M	—
5.5.3.8	Transmission delay time (T_{TD})	M	—
5.5.3.9	Slot time (T_{SL})	M	—
5.5.3.10	Time-out (T_{TO})	M	—
5.5.3.11	GAP update time (T_{GUD})	M	—
5.5.3.12.1	Isochronous cycle time (T_{CT})	O	—
5.5.3.12.2	IsoM synchronization DLPDU time (T_{SYNCH})	O	—
5.5.3.12.3	Active spare time DLPDU time (T_{ASM})	O	—
5.5.3.12.4	Real isochronous cycle time (T_{RCT})	O	—
5.5.3.12.5	Spare time (T_{RES})	O	—
5.5.3.12.6	Passive spare time (T_{PSP})	O	—
5.5.3.12.7	Time shift (T_{SH})	O	—
5.5.3.13	Send delay time (T_{SD})	O	—
5.5.3.14	Receive delay time (T_{RD})	O	—
5.5.3.15	Clock synchronization interval time (T_{CSI})	O	—

Table 237 specifies the CP 3/2 selection of the timers and counters of the Data-link protocol, which are part of DP-master (class 1) and using features named DP-V1 and options.

Table 237 – CP 3/2: Timer and counter selection for DP-V1 master (class 1)

Clause	Timer or counter	Usage	Constraint
5.5.5.1.1	token-rotation-timer	M	—
5.5.5.1.1	idle-timer	M	—
5.5.5.1.1	slot-timer	M	—
5.5.5.1.1	time-out-timer	M	—
5.5.5.1.1	syn-interval-timer	M	—
5.5.5.1.1	GAP-update-timer	M	—
5.5.5.1.1	isochronous-cycle-timer	O	—
5.5.5.1.1	passive-spare-timer	O	—
5.5.5.1.1	send-delay-timer	O	—
5.5.5.1.1	receive-delay-timer	O	—
5.5.5.1.2	DLPDU_sent_count	O	—
5.5.5.1.2	Retry_count	O	—
5.5.5.1.2	DLPDU_sent_count_sr	O	—
5.5.5.1.2	Error_count	O	—
5.5.5.1.2	SD_count	O	—
5.5.5.1.2	SD_error_count	O	—

Table 238 specifies the CP 3/2 selection of the types of DLPDUs of the Data-link protocol, which are part of DP-master (class 1) and using features named DP-V1 and options.

Table 238 – CP 3/2: DLPDU selection for DP-V1 master (class 1)

Clause	DLPDU	Usage	Constraint
7.1	DLPDUs of fixed length with no data field	M	—
7.2	DLPDUs of fixed length with data field	M	Option for sending
7.3	DLPDUs with variable data field length	M	—
7.4	Token DLPDU	M	—
7.5	ASP DLPDU	O	—
7.6	SYNCH DLPDU	O	—
7.7	Time Event (TE) DLPDU	O	—
7.8	Clock Value (CV) DLPDU	O	—

For Clause 8 of IEC 61158-4-3 the following constraints apply:

The CP 3/2 selection of states of the media access and of clock synchronization protocol, which are part of DP-master (class 1) and using features named DP-V0, are the same as specified for CP 3/1 DP-V1-master (class 1) in Table 142 and Table 143.

7.3.2.2.3 Selection for DP-master (class 2)

7.3.2.2.3.1 DP-V0 master (class 2)

The CP 3/2 selection of the time parameters, of timers and counters, of DLPDUs, of states of the media access control and of the clock synchronization protocol, which are part of DP-

master (class 2) and using features named DP-V0, are the same as specified for DP-V0-master (class 1) in 7.3.2.2.2.1.

7.3.2.2.3.2 DP-V1 master (class 2)

Table 239 specifies the CP 3/2 selection of the time parameters of the Data-link protocol, which are part of DP-master (class 2) and using features named DP-V1 and options.

Table 239 – CP 3/2: Time variable selection for DP-V1 master (class 2)

Clause	Variable name	Usage	Constraint
5.5.3.1	Synchronization time (T_{SYN})	M	—
5.5.3.2	Synchronization interval time (T_{SYNI})	M	—
5.5.3.3	Station delay time (T_{SDx})	M	—
5.5.3.4	Quiet time (T_{QUI})	M	—
5.5.3.5	Ready time (T_{RDY})	M	—
5.5.3.6	Safety margin (T_{SM})	M	—
5.5.3.7	Idle time (T_{IDx})	M	—
5.5.3.8	Transmission delay time (T_{TD})	M	—
5.5.3.9	Slot time (T_{SL})	M	—
5.5.3.10	Time-out T_{TO}	M	—
5.5.3.11	GAP update time (T_{GUD})	M	—
5.5.3.12	Isochronous mode	—	—
5.5.3.13	Send delay time (T_{SD})	O	—
5.5.3.14	Receive delay time (T_{RD})	O	—
5.5.3.15	Clock synchronization interval time (T_{CSI})	O	—

Table 240 specifies the CP 3/2 selection of the timers and counters of the Data-link protocol, which are part of DP-master (class 2) and using features named DP-V1 and options.

Table 240 – CP 3/2: Timer and counter selection for DP-V1 master (class 2)

Clause	Timer or counter	Usage	Constraint
5.5.5.1.1	token-rotation-timer	M	—
5.5.5.1.1	idle-timer	M	—
5.5.5.1.1	slot-timer	M	—
5.5.5.1.1	time-out-timer	M	—
5.5.5.1.1	syn-interval-timer	M	—
5.5.5.1.1	GAP-update-timer	M	—
5.5.5.1.1	isochronous-cycle-timer	—	—
5.5.5.1.1	passive-spare-timer	—	—
5.5.5.1.1	send-delay-timer	O	—
5.5.5.1.1	receive-delay-timer	O	—
5.5.5.1.2	DLPDU_sent_count	O	—
5.5.5.1.2	Retry_count	O	—
5.5.5.1.2	DLPDU_sent_count_sr	O	—
5.5.5.1.2	Error_count	O	—
5.5.5.1.2	SD_count	O	—
5.5.5.1.2	SD_error_count	O	—

Table 241 specifies the CP 3/2 selection of the types of DLPDUs of the Data-link protocol, which are part of DP-master (class 2) and using features named DP-V1 and options.

Table 241 – CP 3/2: DLPDU selection for DP-V1 master (class 2)

Clause	DLPDU	Usage	Constraint
7.1	DLPDUs of fixed length with no data field	M	—
7.2	DLPDUs of fixed length with data field	M	Option for sending
7.3	DLPDUs with variable data field length	M	—
7.4	Token DLPDU	M	—
7.5	ASP DLPDU	—	—
7.6	SYNCH DLPDU	—	—
7.7	Time Event (TE) DLPDU	O	—
7.8	Clock Value (CV) DLPDU	O	—

For Clause 8 of IEC 61158-4-3 the following constraints apply:

- a) The CP 3/2 selection of states of the media access, which are part of DP-master (class 2) and using features named DP-V1 and options, are the same as specified for CP 3/1 DP-V0-master (class 1) in Table 138.
- b) The CP 3/1 selection of the clock synchronization protocol, which are part of DP-master (class 2) and using features named DP-V1 and options, are the same as specified for CP 3/1 DP-V1-master (class 1) in Table 143.

7.3.2.2.4 Selection for DP-slave

7.3.2.2.4.1 DP-V0 slave

Table 242 specifies the CP 3/2 selection of the time parameters of the Data-link protocol, which are part of DP-slave and using features named DP-V0.

Table 242 – CP 3/2: Time variable selection for DP-V0 slave

Clause	Variable name	Usage	Constraint
5.5.3.1	Synchronization time (T_{SYN})	M	—
5.5.3.2	Synchronization interval time (T_{SYNI})	M	—
5.5.3.3	Station delay time (T_{SDx})	M	—
5.5.3.4	Quiet time (T_{QUI})	—	—
5.5.3.5	Ready time (T_{RDY})	—	—
5.5.3.6	Safety margin (T_{SM})	—	—
5.5.3.7	Idle time (T_{IDx})	M	—
5.5.3.8	Transmission delay time (T_{TD})	—	—
5.5.3.9	Slot time (T_{SL})	M	—
5.5.3.10	Time-out T_{TO}	M	—
5.5.3.11	GAP update time (T_{GUD})	—	—
5.5.3.12	Isochronous mode	—	—
5.5.3.13	Send delay time (T_{SD})	—	—
5.5.3.14	Receive delay time (T_{RD})	—	—
5.5.3.15	Clock synchronization interval time (T_{CSI})	—	—

Table 243 specifies the CP 3/2 selection of the timers and counters of the Data-link protocol, which are part of DP-slave and using features named DP-V0.

Table 243 – CP 3/2: Timer and counter selection for DP-V0 slave

Clause	Timer or counter	Usage	Constraint
5.5.5.1.1	token-rotation-timer	—	—
5.5.5.1.1	idle-timer	M	—
5.5.5.1.1	slot-timer	—	—
5.5.5.1.1	time-out-timer	M	—
5.5.5.1.1	syn-interval-timer	M	—
5.5.5.1.1	GAP-update-timer	—	—
5.5.5.1.1	isochronous-cycle-timer	—	—
5.5.5.1.1	passive-spare-timer	—	—
5.5.5.1.1	send-delay-timer	—	—
5.5.5.1.1	receive-delay-timer	—	—
5.5.5.1.2	DLPDU_sent_count	—	—
5.5.5.1.2	Retry_count	—	—
5.5.5.1.2	DLPDU_sent_count_sr	—	—
5.5.5.1.2	Error_count	—	—
5.5.5.1.2	SD_count	O	—
5.5.5.1.2	SD_error_count	O	—

Table 244 specifies the CP 3/2 selection of the types of DLPDUs of the Data-link protocol, which are part of DP-slave and using features named DP-V0.

Table 244 – CP 3/2: DLPDU selection for DP-V0 slave

Clause	DLPDU	Usage	Constraint
7.1	DLPDUs of fixed length with no data field	M	—
7.2	DLPDUs of fixed length with data field	M	Option for sending
7.3	DLPDUs with variable data field length	M	—
7.4	Token DLPDU	M	Only for receiving
7.5	ASP DLPDU	—	—
7.6	SYNCH DLPDU	—	—
7.7	Time Event (TE) DLPDU	—	—
7.8	Clock Value (CV) DLPDU	—	—

For Clause 8 of IEC 61158-4-3 the following constraints apply:

- a) The CP 3/2 selection of states of the media access, which are part of DP-slave and using features named DP-V0, are the same as specified for CP 3/1 DP-V0-slave in Table 150.
- b) The CP 3/2 selection of the clock synchronization protocol of the DL-entity of the Data-link protocol, which are part of DP-slave and using features named DP-V0, is empty.

7.3.2.2.4.2 DP-V1 slave

Table 245 specifies the CP 3/2 selection of the time parameters of the Data-link protocol, which are part of DP-slave and using features named DP-V1 and options.

Table 245 – CP 3/2: Time variable selection for DP-V1 slave

Clause	Variable name	Usage	Constraint
5.5.3.1	Synchronization time (T_{SYN})	M	—
5.5.3.2	Synchronization interval time (T_{SYNI})	M	—
5.5.3.3	Station delay time (T_{SDx})	M	—
5.5.3.4	Quiet time (T_{QUI})	—	—
5.5.3.5	Ready time (T_{RDY})	—	—
5.5.3.6	Safety margin (T_{SM})	—	—
5.5.3.7	Idle time (T_{IDx})	M	—
5.5.3.8	Transmission delay time (T_{TD})	—	—
5.5.3.9	Slot time (T_{SL})	M	—
5.5.3.10	Time-out T_{TO}	M	—
5.5.3.11	GAP update time (T_{GUD})	—	—
5.5.3.12	Isochronous mode	—	—
5.5.3.13	Send delay time (T_{SD})	—	—
5.5.3.14	Receive delay time (T_{RD})	O	—
5.5.3.15	Clock synchronization interval time (T_{CSI})	O	—

Table 246 specifies the CP 3/2 selection of the timers and counters of the Data-link protocol, which are part of DP-slave and using features named DP-V1 and options.

Table 246 – CP 3/2: Timer and counter selection for DP-V1 slave

Clause	Timer or counter	Usage	Constraint
5.5.5.1.1	token-rotation-timer	—	—
5.5.5.1.1	idle-timer	M	—
5.5.5.1.1	slot-timer	—	—
5.5.5.1.1	time-out-timer	M	—
5.5.5.1.1	syn-interval-timer	M	—
5.5.5.1.1	GAP-update-timer	—	—
5.5.5.1.1	isochronous-cycle-timer	—	—
5.5.5.1.1	passive-spare-timer	—	—
5.5.5.1.1	send-delay-timer	—	—
5.5.5.1.1	receive-delay-timer	O	—
5.5.5.1.2	DLPDU_sent_count	—	—
5.5.5.1.2	Retry_count	—	—
5.5.5.1.2	DLPDU_sent_count_sr	—	—
5.5.5.1.2	Error_count	—	—
5.5.5.1.2	SD_count	O	—
5.5.5.1.2	SD_error_count	O	—

Table 247 specifies the CP 3/2 selection of the types of DLPDUs of the Data-link protocol, which are part of DP-slave and using features named DP-V1 and Options.

Table 247 – CP 3/2: DLPDU selection for DP-V1 slave

Clause	DLPDU	Usage	Constraint
7.1	DLPDUs of fixed length with no data field	M	—
7.2	DLPDUs of fixed length with data field	M	Option for sending
7.3	DLPDUs with variable data field length	M	—
7.4	Token DLPDU	M	Only for receiving
7.5	ASP DLPDU	O	Only for receiving
7.6	SYNCH DLPDU	O	Only for receiving
7.7	Time Event (TE) DLPDU	O	Only for receiving
7.8	Clock Value (CV) DLPDU	O	Only for receiving

For Clause 8 of IEC 61158-4-3 the following constraints apply:

- a) The CP 3/2 selection of states of the media access, which are part of DP-slave and using features named DP-V1, are the same as specified for CP 3/1 DP-V0-slave in Table 150.
- b) The CP 3/2 selection of states of the clock synchronization protocol, which are part of DP-slave and using features named DP-V1 and Options, are the same as specified for CP 3/1 DP-V1-slave in Table 154.

7.3.3 Application layer

Subclause 7.2.3 applies to CP 3/2. In the application layer there is no difference to CP 3/1.

7.4 Profile 3/3 (PROFINET CBA) – *Void*

8 Communication Profile Family 4 (P-NET®¹⁰)

8.1 General overview

Communication Profile Family 4 defines profiles based on IEC 61158-2 type 4, IEC 61158-3-4, IEC 61158-4-4, IEC 61158-5-4 and IEC 61158-6-4, which corresponds to parts of a communication system commonly known as P-NET.

Profile 4/1 P-NET RS-485

This profile contains AL, DLL and PhL services and protocol references with an IEC 61158 compliant application access. Profile 4/1 is based on ANSI TIA/EIA-485-A, and allows up to 125 devices of normal or simple class to communicate on the same physical link, in half duplex mode.

Profile 4/2 *Void*

Profile 4/3 P-NET on IP

This profile contains AL and DLL services and protocol references with an IEC 61158 compliant application access. Profile 4/3 is based to ISO/IEC 8802-3, and allows up to 125 devices of normal class to communicate on the same logical link, in full duplex mode.

Profile 4/1 is described in this standard, whereas profile 4/3 is described in IEC 61784-2.

8.2 Profile 4/1 (P-NET RS-485)

8.2.1 Physical layer

Table 248 holds the physical layer service and protocol selections from IEC 61158-2 for this profile.

¹⁰ P-NET is the trade name of International P-NET User Organisation ApS (IPUO). This information is given for the convenience of users of this document and does not constitute an endorsement by IEC of the trademark holder or any of its products. Compliance to this profile does not require use of the trade name P-NET. Use of the trade name P-NET requires permission of the trade name holder.

Table 248 – CP 4/1: PhL selection

Clause	Header	Presence	Constraints
1	Scope	YES	—
2	Normative references	Partial	Used if needed
3	Terms and definitions	Partial	Used when applicable
4	Symbols and abbreviations	Partial	Used when applicable
5	Data-link layer – Physical Layer Interface	—	—
5.1	General	YES	—
5.2 – 5.4	—	NO	—
5.5	Type 4: Required services	YES	See text following this table
5.6 – 5.10	—	NO	—
6	Station Management – Physical Layer Interface	—	—
6.1	General	YES	—
6.2	Type 1: Station Management – Physical Layer interface	Partial	Only Ph-SETVALUE and Ph-GETVALUE
6.3	—	NO	—
6.4	Type 4: Station Management – Physical Layer interface	YES	At least, Baud rate 76800 shall be supported. Only half duplex mode shall be supported
6.5 – 6.8	—	NO	—
7 – 8	—	NO	—
9	Medium Dependent Sublayer (MDS)	—	—
9.1	General	YES	—
9.2 – 9.5	—	NO	—
9.6	Type 4: MDS: Wire medium	—	—
9.6.1	Half Duplex	YES	—
9.6.2	Full Duplex	NO	—
9.7 – 9.11	—	NO	—
10 – 23	—	NO	—
24	Type 4: Medium Attachment Unit: RS-485	YES	—
Next clauses	—	NO	—
Next annexes	—	NO	—

Simple class devices shall only support:

- a) Ph-Data request, classes start-of-activity-11, data and end-of-activity.
- b) Ph-DATA indication, classes START-OF-ACTIVITY and DATA.

8.2.2 Data-link layer

8.2.2.1 DLL service selection

Table 249 holds the Data-link layer service selections from IEC 61158-3-4 for this profile.

Table 249 – CP 4/1: DLL service selection

Clause	Header	Presence	Constraints
1	Scope	YES	—
2	Normative references	Partial	Used if needed
3	Terms, definitions, symbols, abbreviations and conventions	Partial	Used when applicable
4	Data-link Service and concepts	YES	—
5	DL-management Service	—	—
5.1	Scope and inheritance	NO	—
5.2	Facilities of the DL-management service	Partial	Bullets a) and b)
5.3	Model of the DL_management service	YES	—
5.4	Constraints on sequence of primitives	Partial	Only the parts referring to DLM-SET and DLM-GET
5.5	SET	YES	—
5.6	GET	YES	—
5.7 – 5.8	—	NO	—

8.2.2.2 DLL protocol selection

Table 250 holds the Data-link layer protocol selections from IEC 61158-4-4 for this profile.

Table 250 – CP 4/1: DLL protocol selection

Clause	Header	Presence	Constraints
1	Scope	YES	—
2	Normative references	Partial	Used if needed
3	Terms and definitions	Partial	Used when applicable
4	Symbols and abbreviations	Partial	Used when applicable
5	Data-link Protocol definition	YES	^a

^a A device shall provide at least the necessary protocol options to fulfill the supported services.

For this profile, only half duplex transmission, as defined in 4.1.2.2 of IEC 61158-4-4, should be supported.

Simple class devices should support responder functionality only, as defined in 4.1.1 of IEC 61158-4-4.

8.2.3 Application layer

8.2.3.1 AL service selection

Table 251 holds the application layer service selections from IEC 61158-5-4 for this profile.

Table 251 – CP 4/1: AL service selection

Clause	Header	Presence	Constraints
Whole document	Application layer service definition – Type 4 elements	YES	Used up to the exceptions below
5.3.2.1	Application relationship formal model	YES	At least, baudrate 76 800 shall be supported

Simple class devices shall only support Real Variable Objects, defined in 5.2.5.2 of IEC 61158-5-4 (not Proxy Variable Objects) and only the objects needed for the variable types, which are actually present in the device.

Normal class devices shall support the Real Variable Objects needed for the variable types, which are actually present in the device, and Proxy Variable Objects for all of the variable types listed in 5.2 of IEC 61158-5-4.

Simple class devices shall not support the RESPONSE Service, defined in 5.2.6.2 of IEC 61158-5-4.

8.2.3.2 AL protocol selection

Table 252 holds the application layer protocol selections from IEC 61158-6-4 for this profile.

Table 252 – CP 4/1: AL protocol selection

Clause	Header	Presence	Constraints
Whole document	Application layer protocol specification – Type 4 elements	YES	^a
^a A device shall provide at least the necessary protocol options to fulfill the supported services.			

9 Communication Profile Family 5 (WorldFIP®¹¹)

9.1 General overview

The WorldFIP network is a very flexible and versatile transmission system. The range of functions and performances permit the definition of a large number of profiles to match exactly the requirements of the applications. As a practical approach, the three most popular profiles are developed in this International Standard; they address both time critical context and mission critical functions. Other profiles will be defined for purpose specific application by selecting the appropriate services and protocols in the IEC 61158 series, but respecting the minimum core which is necessary to set up, operate and monitor the network.

All the terms are defined in the base standards: IEC 61158-2, IEC 61158-3-7, IEC 61158-4-7, IEC 61158-5-7 and IEC 61158-6-7.

All the defined profiles are composed of a selection of services and protocols from the IEC 61158 series, Type 7, and tuned by a selection of particular parameters within each service or protocol.

¹¹ WorldFIP is the trade name of ALSTOM company. This information is given for the convenience of users of this document and does not constitute an endorsement by IEC of the trade names holder or any of its products. Compliance to this profile does not require use of the registered trade name. Use of the trade names requires permission of the trade name holder.

All the WorldFIP profiles are based on a common core set of services of MPS, to which is added an appropriated selection of services providing from one or more selected appropriated features.

The following table summarizes the element selection of the relative profiles.

Table 253 – CPF 5: overview of profile sets

	Profile 5/1	Profile 5/2	Profile 5/3
Application	(MPS, MCS) of IEC 61158-5-7, IEC 61158-6-7	(MPS, MCS, SubMMS) of IEC 61158-5-7, IEC 61158-6-7	(MPS) of IEC 61158-5-7, IEC 61158-6-7
Data-link	IEC 61158-3-7, IEC 61158-4-7	IEC 61158-3-7, IEC 61158-4-7	IEC 61158-3-7, IEC 61158-4-7
Physical	Type 1 of IEC 61158-2	Type 1 of IEC 61158-2	Type 1 of IEC 61158-2

The selection defined in Table 253 represents the most frequently basic used profiles.

The distinctive features of the different profiles in the basic version are the following:

- Profile 5/1, long messages, wide network topology, loose time-critical purpose-built application layer;
- Profile 5/2, large messages, tight time-critical exchanges, mission-critical application, IEC 61158-5-7 and IEC 61158-6-7 (application layer);
- Profile 5/3, open WorldFIP interface for other purpose-built or standardized tight time-critical application layers (segmented or not).

NOTE See Clause A.5 for an overview of WorldFIP communications concepts.

It should be emphasized that profile 5/3 may be fitted with web type upper stack profile containing TCP/IP, BSD sockets, HTTP over DLL access point. The addition of this side stack does not impact the profile definition. This important feature permits a TRANSPARENT access of Fieldbus device from remote browser, as long as the field devices implement an EMBEDDED SERVER. This is an additional integration provided by the profiles to federate intelligent Field device into distributed Control Systems.

The physical layers indicated in this International Standard are those relative to the selected profiles. But variants may be defined in the future, using other WorldFIP approved physical layer options for further applications such as high speed radio or very high speed on fiber or copper.

9.2 Profile 5/1 (WorldFIP)

9.2.1 Physical layer

Table 254 specifies the physical layer profile within IEC 61158-2. It is common to all of the CPF 5 profiles.

Table 254 – CPF 5: PhL selection

Clause	Header	Presence	Constraints
1	Scope	YES	—
2	Normative references	Partial	Used if needed
3	Terms and definitions	—	—
3.1	Common terms and definitions	Partial	Used when applicable
3.2	Type 1: Terms and definitions	YES	—
3.3 – 3.7	—	NO	—
4	Symbols and abbreviations	—	—
4.1	Symbols	—	—
4.1.1	Type 1: Symbols	YES	—
4.1.2 – 4.1.6	—	NO	—
4.2	Abbreviations	—	—
4.2.1	Type 1: Additional abbreviations	YES	—
4.2.2 – 4.2.6	—	NO	—
5	Data-link layer – Physical Layer interface	—	—
5.1	General	Partial	Used as needed
5.2	Type 1: Required services	YES	—
5.3 – 5.7	—	NO	—
6	Station Management – Physical Layer interface	—	—
6.1	General	Partial	Used as needed
6.2	Type 1: Station Management – Physical Layer interface	Partial	Used as needed
6.3 – 6.7	—	NO	—
7	DCE Independent Sublayer (DIS)	—	—
7.1	General	Partial	Used as needed
7.2	Type 1: DIS	YES	—
7.3 – 7.5	—	NO	—
8	DTE – DCE interface	NO	—
9	Medium Dependent Sublayer (MDS)	NO	—
10	MDS – MAU interface	—	—
10.1	General	Partial	Used as needed
10.2	Type 1: MDS — MAU interface: wire and optical media	Partial	Used as appropriate
10.3 – 10.6	—	NO	—
11	Type 1 and 7: Medium Attachment Unit: voltage mode, linear-bus-topology 150 Ω twisted-pair wire medium	Partial	See Note
12	Type 1 and 3: Medium Attachment Unit: 31,25 kbit/s, voltage-mode with low-power option, bus- and tree-topology, 100 Ω wire medium	YES	See Note
13 – 14	—	NO	—
15	Type 1 and 7: Medium Attachment Unit: dual-fiber optical media	YES	See Note
16 – 20	—	NO	—
21	Type 3: Medium Attachment Unit: Synchronous transmission, 31,25 kbit/s, voltage mode, wire medium	YES	See Note
Next clauses	—	NO	—
Annex A	Type 1: Connector specification		
A.1	Internal Connector for wire medium	YES	See Note

Clause	Header	Presence	Constraints
A.2	External Connectors for wire medium	YES	See Note
A.3	External Connectors for optical medium	YES	See Note
Annex B	Type 1: Cable specifications and trunk and spur lengths for the 31,25 kbit/s voltage-mode MAU	YES	See Note
Annex C	Type 1: Optical passive stars	YES	See Note
Annex D	Type 1: Star topology	YES	See Note
Annex E	Type 1: Alternate fibers	YES	See Note
Next annexes		NO	—
NOTE The selection could be an alternate solution for the specified profile.			

9.2.2 Data-link layer

9.2.2.1 DLL service selection

9.2.2.1.1 General

Table 255 specifies the DLL service selection within IEC 61158-3-7 for this profile. It is common to all of the CPF 5 profiles.

Table 255 – CPF 5: DLL service selection

Clause	Header	Presence	Constraints
1	Scope	YES	—
2	Normative references	Partial	Used as needed
3	Terms, definitions, symbols, abbreviations and conventions	Partial	Used as needed
4	Data-link layer services and concepts	Partial	Used as needed

Table 256 – CPF 5: DLL service selection of Clause 4

Clause	Header	Presence	Constraints
4.1	Field of application, object	YES	—
4.2	General description of services	YES	—
4.3	Sequences of primitives	YES	—
4.4	Buffer writing	YES	See Note 1
4.5	Buffer reading	YES	See Note 1
4.6	Buffer transfer	YES	—
4.7	Explicit request for buffer transfer	Partial	See Note 2
4.8	Unacknowledged message transfer	Partial	See Note 3
4.9	Acknowledged message transfer	Partial	See Note 3
NOTE 1 The maximum length of exchanged DLS-user-data can be either 120 or 128 bytes.			
NOTE 2 The two update services are each optional.			
NOTE 3 The service is optional. When implemented, the maximum length of exchanged DLS-user-data can be either 122 or 256 bytes.			

9.2.2.2 DLL protocol selection

Table 257 specifies the DLL protocol selection within IEC 61158-4-7 for this profile. It is common to all of the CPF 5 profiles.

Table 257 – CPF 5: DLL protocol selection

Clause	Header	Presence	Constraints
1	Scope	YES	—
2	Normative references	Partial	Used as needed
3	Terms, definitions, symbols and abbreviations	Partial	Used as needed
4	Overview of the DL-protocol	YES	See Table 258 for a list of mandatory and optional variables and resources
5	General structure and encoding of PhIDUs and DLPDUs and related elements of procedure	YES	See Table 259 for a list of mandatory and optional DLPDUs
6	DLPDU-specific structure, encoding and element of procedure	YES	—
7	DL-service elements of procedure, interfaces and conformance	YES	—
Annex A	Exemplary FCS implementations	YES	—
Annex B	Object modeling	YES	—
Annex C	Topology of multi-segment DL-subnetwork	YES	—
Annex D	Management of transmission errors	YES	—

Table 258 – CPF 5: DLL protocol selection of variables and resources

Clause	Variable or resource name	Usage	Constraints
4.2.1	B_DAT_Prod	M	—
4.2.1	B_REQ	O	—
4.2.1	Q_MSGcyc	O	—
4.2.1	RQ	O	—
4.2.1	PR	O	—
4.2.1	RQ-INHIBIT	O	—
4.2.1	B_DAT_Cons	M	—
4.2.1	Q_MSGaper	O	—
4.2.1	Q_MSGrec	O	—
4.2.1	Q_REQ1	O	—
4.2.1	Q_REQ2	O	—
4.2.2	Q_IDRQ1	O	—
4.2.2	Q_IDRQ2	O	—
4.2.2	Q_RPRQ	O	—
4.2.2	Q_IDMSG	O	—

Table 259 – CPF 5: DLL protocol selection of DLPDUs

Clause	DLPDU name	Usage	Constraints
5.5.1	ID_DAT	M	—
5.5.1	ID_MSG	O	—
5.5.1	ID_RQ1	O	See Note
5.5.1	ID_RQ2	O	See Note
5.5.2	RP_DAT	M	See Note
5.5.2	RP_DAT_MSG	O	See Note
5.5.2	RP_DAT_RQ1	O	See Note
5.5.2	RP_DAT_RQ2	O	See Note
5.5.2	RP_DAT_RQ1_MSG	O	See Note
5.5.2	RP_DAT_RQ2_MSG	O	See Note
5.5.4	RP_MSG_ACK	O	See Note
5.5.4	RP_MSG_NOACK	O	See Note
5.5.5	RP_ACK+	O	—
5.5.5	RP_ACK-	O	—
5.5.3	RP_RQ1	O	—
5.5.3	RP_RQ2	O	—
5.5.6	RP_END	O	—

NOTE The need for this DLPDU is implementation dependent.

9.2.3 Application layer

9.2.3.1 AL service selection

Table 260 specifies the AL service selection within IEC 61158-5-7 for this profile.

Table 260 – CP 5/1: AL service selection

Clause	Header	Presence	Constraints
1	Scope	YES	
2	Normative references	Partial	Used as needed
3	Terms, definitions, symbols, abbreviations and conventions	Partial	Used as needed
4	Concepts	YES	Used as needed
5	Data type ASE	YES	—
6	Communication model specification	Partial	See Table 261
Annex A	Model for Service Error Reporting	NO	—

Table 261 – CP 5/1: AL service selection of ASEs

Clause	Header	Presence	Constraints
6.2.1	MPS ASE (periodic/aPeriodic manufacturing services)	Partial	See Table 262 and Table 266
6.2.2	Virtual model of a device (VMD) ASE	NO	—
6.2.3	Domain ASE	NO	—
6.2.4	Program invocation (PI) ASE	NO	—
6.2.5	Variable ASE	NO	—
6.2.6	Event ASE	NO	—
6.2.7	Directory ASE	NO	—
6.3.1	Messaging common service (MCS) AR ASE	Partial	See Table 270

Table 262 – CPF 5: AL service selection of MPS ASEs

Clause	Header	Presence	Constraints
6.2.1.3.2.2	Variable generic class specification	Partial	See Table 263
6.2.1.3.2.4	Produced variable class specification	Partial	See Table 264
6.2.1.3.2.6	Consumed variable class specification	Partial	See Table 265
6.2.1.3.2.8	Third party variable class specification	NO	—
6.2.1.3.2.10	Type constructor class specification	NO	—
6.2.1.4	Variable list	NO	—

Table 263 – CPF 5: AL service selection of variable elements

Parameter ref.	Parameter name	Usage	Constraints
6.2.1.3.2.2	A_Name	M	—
6.2.1.3.2.2	Reference Type Constructor	NO	—
6.2.1.3.2.2	Transmitted Status	M	—
6.2.1.3.2.2	Significant Status	M	—
6.2.1.3.2.2	Identifier	M	—
6.2.1.3.2.2	Transmission Mode	M	See Note
6.2.1.3.2.2	Network Period	M	—
6.2.1.3.2.2	Class	M	Normal only
6.2.1.3.2.2	Consistency Variable	NO	—
6.2.1.3.2.2	Reference variable list	NO	—
6.2.1.3.2.2	Public value	M	See Note
6.2.1.3.2.2	Universal services requested	NO	—

NOTE This parameter is implementation dependent.

Table 264 – CPF 5: AL service selection of produced variable elements

Parameter ref.	Parameter name	Usage	Constraints
6.2.1.3.2.4	Refreshment Elaborated	O	Asynchronous only
6.2.1.3.2.4	Punctual Refreshment Elaborated	NO	—
6.2.1.3.2.4	Resynchronization Variable	NO	—
6.2.1.3.2.4	Emission Indication	O	—

Table 265 – CPF 5: AL service selection of consumed variable elements

Parameter ref.	Parameter name	Usage	Constraints
6.2.1.3.2.6	Promptness Elaborated	O	Asynchronous only
6.2.1.3.2.6	Punctual Promptness Elaborated	NO	—
6.2.1.3.2.6	Resynchronization Variable	NO	—
6.2.1.3.2.6	Reception Indication	O	—

Table 266 – CP 5/1: AL service selection of MPS services

Service ref.	Service name	Usage	Constraint
6.2.1.3.4.2	A_Readloc	M	See Table 267
6.2.1.3.4.3	A_Writeloc	M	—
6.2.1.3.4.4	A_Update	O	—
6.2.1.3.4.5	A_Readfar	O	See Table 267
6.2.1.3.4.6	A_Writefar	O	—
6.2.1.3.4.7	A_Send	M	—
6.2.1.3.4.8	A_Received	M	—
6.2.1.3.5.2	A_Read	O	See Table 267
6.2.1.3.5.3	A_Write	O	—
6.2.1.4.3.1	A_Readlist	NO	—

Table 267 – CP 5/1, 5/2: AL service selection of A_Readloc service parameters

Parameter ref.	Parameter name	Usage	Constraint
6.2.1.3.4.2	Variable Specification	M	—
6.2.1.3.4.2	Value	M	—
6.2.1.3.4.2	Refreshment status	O	—
6.2.1.3.4.2	Punctual Refreshment Status	NO	—
6.2.1.3.4.2	Promptness Status	O	—
6.2.1.3.4.2	Punctual Promptness Status	NO	—

Table 268 – CP 5/1, 5/2: AL service selection of A_Readfar service parameters

Parameter ref.	Parameter name	Usage	Constraint
6.2.1.3.4.5	Variable Specification	M	—
6.2.1.3.4.5	Priority	M	—
6.2.1.3.4.5	Value	M	—
6.2.1.3.4.5	Refreshment status	O	—
6.2.1.3.4.5	Punctual Refreshment Status	NO	—
6.2.1.3.4.5	Promptness Status	O	—
6.2.1.3.4.5	Punctual Promptness Status	NO	—

Table 269 – CP 5/1, 5/2: AL service selection of A_Read service parameters

Parameter ref.	Parameter name	Usage	Constraint
6.2.1.3.5.2	Variable Specification	M	—
6.2.1.3.5.2	Priority	M	—
6.2.1.3.5.2	Value	M	—
6.2.1.3.5.2	Refreshment status	O	—
6.2.1.3.5.2	Punctual Refreshment Status	NO	—
6.2.1.3.5.2	Promptness Status	O	—
6.2.1.3.5.2	Punctual Promptness Status	NO	—

Table 270 – CP 5/1: AL service selection of MCS service classes

Class ref.	Class name	Usage	Constraints
6.3.1.2	negotiated	NO	—
6.3.1.2	predefined	M	See Table 271 and Table 272
6.3.1.2	without negotiation	NO	—

Table 271 – CP 5/1: AL service selection of QoS

QoS ref.	QoS name	Usage	Constraints
6.3.1.2.3.2	Duration of Establishment	NO	—
6.3.1.2.3.3	PDU size	M	See Note
6.3.1.2.3.4	Transfer Rate	M	1, Cyclical channel
6.3.1.2.3.5	Number of Retries	M	Number = 1
6.3.1.2.3.6	Anticipation Factor	M	Number = 0 or 1; see Note
6.3.1.2.3.7	SDU Size	M	User SDU size ≤ 64K Bytes
6.3.1.2.3.8	Termination Duration	NO	—
6.3.1.2.3.9	Priority	NO	—

NOTE The QoS is implementation dependent.

Table 272 – CP 5/1: AL service selection of MCS services

Service ref.	Service name	Usage	Constraint
6.3.1.3.2	A_Associate	NO	—
6.3.1.3.3	A_Release	NO	—
6.3.1.3.4	A_Abort	NO	—
6.3.1.3.5	A_Data	Partial	See Table 273
6.3.1.3.6	A_Unidata	NO	—

Table 273 – CP 5/1, 5/2: AL service selection of A_Data parameters

Parameter ref.	Parameter name	Usage	Constraint
6.3.1.3.5.2	Acknowledgement request	M	—
6.3.1.3.5.2	User information	M	User SDU size ≤ 64K Bytes
6.3.1.3.5.2	Transfer result	M	—

9.2.3.2 AL protocol selection

Table 274 specifies the AL protocol selection within IEC 61158-6-7 for this profile.

Table 274 – CP 5/1: AL protocol selection

Clause	Header	Presence	Constraints
1	Scope	YES	—
2	Normative references	Partial	Used as needed
3	Terms and definitions	Partial	Used as needed
4 – 11	See 61158-6-7	YES	See Table 275 through Table 279

No constraints are specified in the ASN1 types. Table 275 indicates the constraint on the types that differ from the ASN1 types.

Table 275 – CPF 5/1: AL protocol selection of MPS data types

Clause	Header	Presence	Constraints
4.1.1	Boolean	YES	—
4.1.2	Integer	YES	—
4.1.3	Bit String	YES	—
4.1.4	Octet String	YES	—
4.1.5	Sequence	YES	—
4.1.6	Choice	YES	—
4.1.7	Null	YES	—
4.1.8	Object Identifier	YES	—
4.1.9	Default	NO	—

Table 276 – CPF 5/1: AL protocol selection of MPS PDUs

Clause	Header	Presence	Constraints
5.2.1.4.2	VariableCompactValue PDU	YES	—
5.2.1.4.3	ExplicitVariableValue PDU	NO	—
5.2.1.4.4	VariableDescription PDU	NO	—
5.2.1.4.5	AccessDescription PDU	NO	—
5.2.1.4.6	TypeDescription PDU	NO	—
5.2.1.3.6	ListDescription PDU	NO	—
5.2.1.3.7	PDU Extensions	NO	—

Table 277 – CPF 5/1: AL protocol selection of MPS encoding rules

Clause	Header	Presence	Constraints
5.2.1.4.2.2	Boolean	YES	—
5.2.1.4.2.3	Integer	YES	—
5.2.1.4.2.4	Bitstring	YES	—
5.2.1.4.2.5	Unsigned	YES	—
5.2.1.4.2.6	Octetstring	YES	—
5.2.1.4.2.7	Visiblestring	YES	—
5.2.1.4.2.8	Generalized Time	YES	—
5.2.1.4.2.9	Floating Point	YES	—
5.2.1.4.2.10	Binary time	YES	—
5.2.1.4.2.11	BCD	YES	—
5.2.1.4.2.12	Structure	YES	—
5.2.1.4.2.13	Array	NO	—
5.2.1.4.2.14	Compact Encoding Boolean Array	NO	—
5.2.1.4.2.15	Compact Encoding BCD Array	NO	—

Table 278 – CP 5/1, 5/2: AL protocol selection of MCS PDUs

Clause	Header	Presence	Constraints
5.2.2.2.2	Association Establishment Request	NO	—
5.2.2.2.3	Association Establishment Response	NO	—
5.2.2.2.4	Association Termination Request	NO	—
5.2.2.2.5	Association Termination Response	NO	—
5.2.2.2.6	Association Revocation Request	NO	—
5.2.2.2.7	Associated Transfer Request	YES	—
5.2.2.2.8	Associated Transfer Acknowledgement	YES	—
5.2.2.2.9	non-Associated Transfer	NO	—
5.2.2.2.10	non-Associated Transfer Acknowledgement	NO	—

Table 279 – CP 5/1: AL protocol selection of MCS state machines

Clause	State machine	Presence	Constraints
10.2.5.3.2	TS_SM_RQ	YES	—
10.2.5.3.3	TS_SM_ACC	YES	—
10.2.5.4.2	AT_SM_RQ	YES	—
10.2.5.4.3	AT_SM_ACC	YES	—
10.2.5.5.2	ATAK_SM_RQ	YES	—
10.2.5.5.3	ATAK_SM_ACC	YES	—
10.2.5.5.4	NB_SM	YES	—
10.2.5.6	RC_SM	YES	—
10.2.5.7	DU_SM	YES	—
10.2.5.8	MA_SM	YES	—
10.2.5.9	SG_SM	YES	—
10.2.5.10	RS_SM	YES	—

9.3 Profile 5/2 (WorldFIP)

9.3.1 Physical layer

See Table 254.

9.3.2 Data-link layer

See 9.2.2.

9.3.3 Application layer

9.3.3.1 AL service selection

Table 280 specifies the AL service selection within IEC 61158-5-7 for this profile.

Table 280 – CP 5/2: AL service selection

Clause	Header	Presence	Constraints
1	Scope	YES	—
2	Normative references	Partial	Used as needed
3	Terms and definitions	Partial	Used as needed
4 – 12	—	NO	—
13	Communication model type 7 specification	Partial	See Table 281
14	—	NO	—
Annex A	Model for Service Error Reporting	NO	—

Table 281 – CP 5/2: AL service selection of ASEs

Clause	Header	Presence	Constraints
6.2.1	MPS ASE (periodic/aPeriodic manufacturing services)	Partial	See Table 262 and Table 282
6.2.2	Virtual model of a device (VMD) ASE	NO	—
6.2.3	Domain ASE	Partial	See Table 286 and Table 287
6.2.4	Program invocation (PI) ASE	Partial	See Table 288 and Table 289
6.2.5	Variable ASE	Partial	See Table 290 and Table 291
6.2.6	Event ASE	NO	—
6.2.7	Directory ASE	NO	—
6.3.1	Messaging common service (MCS) AR ASE	Partial	See Table 283

Table 282 – CP 5/2: AL service selection of MPS services

Service ref.	Service name	Usage	Constraint
6.2.1.3.4.2	A_Readloc	M	See Table 267
6.2.1.3.4.3	A_Writeloc	M	—
6.2.1.3.4.4	A_Update	O	—
6.2.1.3.4.5	A_Readfar	O	See Table 268
6.2.1.3.4.6	A_Writefar	O	—
6.2.1.3.4.7	A_Send	O	—
6.2.1.3.4.8	A_Received	O	—
6.2.1.3.5.2	A_Read	O	See Table 269
6.2.1.3.5.3	A_Write	O	—
6.2.1.4.3.1	A_Readlist	NO	—

Table 283 – CP 5/2: AL service selection of MCS service classes

Class ref.	Class Name	Usage	Constraints
6.3.1.2	negotiated	NO	—
6.3.1.2	predefined	Partial	See Table 284 and Table 285
6.3.1.2	Without negotiation	NO	—

Table 284 – CP 5/2: AL service selection of QoS

QoS ref.	QoS Name	Usage	Constraints
6.3.1.2.3.2	Duration of Establishment	NO	—
6.3.1.2.3.3	PDU size	M	See Note
6.3.1.2.3.4	Transfer Rate	M	—
6.3.1.2.3.5	Number of Retries	M	—
6.3.1.2.3.6	Anticipation Factor	M	—
6.3.1.2.3.7	SDU Size	M	User SDU size ≤ 64K Bytes
6.3.1.2.3.8	Termination Duration	NO	—
6.3.1.2.3.9	Priority	NO	—

NOTE The QoS is implementation dependent.

Table 285 – CP 5/2: AL service selection of MCS services

Service ref.	Service name	Usage	Constraint
6.3.1.3.2	A_Associate	NO	—
6.3.1.3.3	A_Release	NO	—
6.3.1.3.4	A_Abort	NO	—
6.3.1.3.5	A_Data	M	See Table 273
6.3.1.3.6	A_Unidata	NO	—

Table 286 – CP 5/2: AL service selection of domain services

Service ref.	Service name	Usage	Constraint
6.2.3.3.1	Confirmed delete domain	M	—
6.2.3.3.2	Confirmed initiate download sequence	M	—
6.2.3.3.3	Confirmed download segment	M	—
6.2.3.3.4	Confirmed terminate download sequence	M	—
6.2.3.3.5	Confirmed initiate upload sequence	M	—
6.2.3.3.6	Confirmed upload segment	M	—
6.2.3.3.7	Confirmed terminate upload sequence	M	—
6.2.3.3.8	Confirmed Get domain attribute	NO	—

Table 287 – CP 5/2: AL service selection of domain object attributes

Attribute ref.	Attribute Name	Usage	Constraint
6.2.3.2	Domain name	M	—
6.2.3.2	Domain index	M	—
6.2.3.2	State	M	—
6.2.3.2	Predefined	M	—
6.2.3.2	sharable	M	—
6.2.3.2	List of Program invocation identification	M	—
6.2.3.2	Upload in progress	Y	—
6.2.3.2	Domain protection	NO	—
6.2.3.2	Extension	NO	—

Table 288 – CP 5/2: AL service selection of program services

Service ref.	Service name	Usage	Constraint
6.2.4.3.1	Create program invocation	M	—
6.2.4.3.2	Delete program invocation	M	—
6.2.4.3.3	Start	M	—
6.2.4.3.4	Stop	M	—
6.2.4.3.5	Resume	M	—
6.2.4.3.6	Reset	M	—
6.2.4.3.7	Confirmed Kill	M	—
	Get program invocation attribute	NO	—

Table 289 – CP 5/2: AL service selection of program object attributes

Attribute ref.	Attribute Name	Usage	Constraint
6.2.4.2	PI name	M	—
6.2.4.2	PI index	M	—
6.2.4.2	PI State	M	—
6.2.4.2	List of Domain identification	M	—
6.2.4.2	Sub-MMS deletable	M	—
6.2.4.2	Reusable	M	—
6.2.4.2	Execution argument	M	—
6.2.4.2	PI Access Protection	NO	—
6.2.4.2	Extension	NO	—

Table 290 – CP 5/2: AL service selection of variable services

Service ref.	Service name	Usage	Constraint
6.2.5.3.1	Confirmed read service	M	—
6.2.5.3.2	Confirmed write service	M	—
6.2.5.3.3	Unconfirmed information report	M	—
6.2.5.3.4	Confirmed define variable list service	NO	—
6.2.5.3.5	Confirmed delete variable list service	NO	—
6.2.5.3.6	Confirmed get variable access attribute service	NO	—
6.2.5.3.7	Confirmed get variable list attribute service	NO	—

Table 291 – CP 5/2: AL service selection of variable classes

Service ref.	Service name	Usage	Constraint
6.2.5.2	Variable	M	See Table 292
6.2.5.2.3	Variable list	NO	—

Table 292 – CP 5/2: AL service selection of variable class attributes

Service ref.	Service name	Usage	Constraint
6.2.5.3.1	Confirmed read service	M	—
6.2.5.3.2	Confirmed write service	M	—
6.2.5.3.3	Unconfirmed information report	M	—
6.2.5.3.4	Confirmed define variable list service	NO	—
6.2.5.3.5	Confirmed delete variable list service	NO	—
6.2.5.3.6	Confirmed get variable access attribute service	NO	—
6.2.5.3.7	Confirmed get variable list attribute service	NO	—

9.3.3.2 AL protocol selection

Table 293 specifies the AL protocol selection within IEC 61158-6-7 for this profile.

Table 293 – CP 5/2: AL protocol selection

Clause	Header	Presence	Constraints
1	Scope	YES	—
2	Normative references	Partial	Used as needed
3	Terms and definitions	Partial	Used as needed
4 – 11	See 61158-6-7	YES	See Table 275 through Table 278, and Table 294 through Table 296

No constraints are specified in the ASN1 types. Table 275 indicates the constraint on the types that differ from the ASN1 types.

Table 294 – CP 5/2: AL protocol selection of MCS state machines

Clause	Header	Presence	Constraints
10.2.5.3.2	TS_SM_RQ	YES	—
10.2.5.3.3	TS_SM_ACC	YES	—
10.2.5.4.2	AT_SM_RQ	YES	—
10.2.5.4.3	AT_SM_ACC	YES	—
10.2.5.5.2	ATAK_SM_RQ	YES	—
10.2.5.5.3	ATAK_SM_ACK	YES	—
10.2.5.5.4	NB_SM	YES	—
10.2.5.6.	RC_SM	YES	—
10.2.5.7	DU_SM	YES	—
10.2.5.8	MA_SM	YES	—
10.2.5.9	SG_SM	YES	—
10.2.5.10	RS_SM	YES	—
10.2.6.2.2	NT_SM_RQ	YES	—
10.2.6.2.3	NT_SM_ACC	YES	—
10.2.6.3.2	NTAK_SM_RQ	YES	—
10.2.6.3.3	NTAK_SM_ACC	YES	—

Table 295 – CP 5/2: AL protocol selection of sub-MMS coding rules

Clause	Header	Presence	Constraints
5.2.1.4.2.2	Boolean	NO	—
5.2.1.4.2.3	Integer	YES	—
5.2.1.4.2.4	Bitstring	NO	—
5.2.1.4.2.5	Unsigned	YES	—
5.2.1.4.2.6	Octetstring	YES	—
5.2.1.4.2.7	Visiblestring	NO	—
5.2.1.4.2.8	Generalized Time	NO	—
5.2.1.4.2.9	Floating point	YES	—
5.2.1.4.2.10	Binary time	NO	—
5.2.1.4.2.11	BCD	NO	—
5.2.1.4.2.12	Structure	YES	—
5.2.1.4.2.13	Array	YES	—

Table 296 – CP 5/2: AL protocol selection of sub-MMS PDUs

Clause	Header	Presence	Constraints
5.2.3.1	Confirmed-reqPDU	YES	—
5.2.3.1	Confirmed-resp DU	YES	—
5.2.3.1	Confirmed-errorPDU	YES	—
5.2.3.1	unconfirmedPDU	YES	—
5.2.3.1	rejectPDU	YES	—
5.2.3.1	Initiate-reqPDU	NO	—
5.2.3.1	Initiate-respPDU	NO	—
5.2.3.1	Initiate-errorPDU	NO	—
5.2.3.1	Conclude-reqPDU	NO	—
5.2.3.1	Conclude-respPDU	NO	—
5.2.3.1	Conclude-errorPDU	NO	—

9.4 Profile 5/3 (WorldFIP)

9.4.1 Physical layer

See Table 254.

9.4.2 Data-link layer

See 9.2.2.

9.4.3 Application layer

9.4.3.1 AL service selection

Table 297 specifies the AL service selection within IEC 61158-5-7 for this profile.

Table 297 – CP 5/3: AL service selection

Clause	Header	Presence	Constraints
1	Scope	YES	—
2	Normative references	Partial	Used as needed
3	Terms, definitions, symbols, abbreviations and conventions	Partial	Used as needed
4	Concepts	YES	Used as needed
5	Data type ASE	YES	—
6	Communication model specification	Partial	See Table 298
Annex A	Model for Service Error Reporting	NO	—

Table 298 – CP 5/3: AL service selection of ASEs

Clause	Header	Presence	Constraints
6.2.1	MPS ASE (periodic/aPeriodic manufacturing services)	Partial	See Table 262 and Table 266
6.2.2	Virtual model of a device (VMD) ASE	NO	—
6.2.3	Domain ASE	NO	—
6.2.4	Program invocation (PI) ASE	NO	—
6.2.5	Variable ASE	NO	—
6.2.6	Event ASE	NO	—
6.2.7	Directory ASE	NO	—
6.3.1	Messaging common service (MCS) AR ASE	NO	—

9.4.3.2 AL protocol selection

Table 299 specifies the AL protocol selection within IEC 61158-6-7 for this profile.

Table 299 – CP 5/3: AL protocol selection

Clause	Header	Presence	Constraints
1	Scope	YES	—
2	Normative references	Partial	Used as needed
3	Terms and definitions	Partial	Used as needed
4 – 11	See 61158-6-7	YES	See Table 275 through Table 277

No constraints are specified in the ASN1 types. Table 275 indicates the constraints on the types that differ from the ASN1 types.

10 Communication Profile Family 6 (INTERBUS®¹²)

10.1 General overview

Communication Profile Family 6 defines communication profiles based on IEC 61158-2 type 8, IEC 61158-3-8, IEC 61158-4-8, IEC 61158-5-8 and IEC 61158-6-8, which corresponds to parts of a communication system commonly known as INTERBUS.

- Profile 6/1
This profile contains a selection of AL, DLL and PhL services and protocol definitions with an IEC 61158 compliant application access.

Profile 6/1 defines a generic standard INTERBUS profile.

- Profile 6/2
This profile contains a selection of AL, DLL and PhL services and protocol definitions with an IEC 61158 compliant application access plus an additional AL protocol transparent access path.

¹² INTERBUS is the trade name of Phoenix Contact GmbH & Co. KG., control of trade name use is given to the non profit organisation INTERBUS Club. This information is given for the convenience of users of this document and does not constitute an endorsement by IEC of the trademark holder or any of its products. Compliance to this profile does not require use of the trade name INTERBUS. Use of the trade name INTERBUS requires permission of the INTERBUS Club.

Profile 6/2 extends profile 6/1 non cyclic data exchange capabilities. It provides, via AR-Send-Data-Acknowledge, transparent access to field devices. This allows to fit devices with other protocol stacks like TCP/IP and applications based on TCP/IP. Which protocol stacks are using AR-Send-Data-Acknowledge does not impact the profile definition.

– Profile 6/3

This profile contains a selection of AL, DLL and PhL services and protocol definitions with an IEC 61158 compliant application access with a limited set of AL services.

Profile 6/3 uses a reduced set of services for non cyclic data exchange for the use in device with limited resources.

NOTE See Clause A.6 for an overview of INTERBUS communications concepts.

Devices, master or slave, which comply with a communication profile can be further classified by a CP identifier. The CP identifiers are shown in Table 300.

Table 300 – CPF 6: device CP identifier assignment

Profile	Master		Slave			Bus coupler
	cyclic	cyclic and non cyclic	cyclic	non cyclic	cyclic and non cyclic	
Profile 6/1	618	619	611	612	613	614
Profile 6/2	—	629	—	622	623	—
Profile 6/3	—	639	—	632	633	—

Each communication profile provides a well defined set of provisions. For a distinct device further selections of services, parameter and parameter values have to be made. These selections should be described according to ISO 15745-3 as INTERBUS device profiles in the form of an INTERBUS device profile exchange description. An INTERBUS device profile based on a CP shall specify the CP identifier in the following format:

```
<communicationEntity ... communicationProfile="[CP identifier]" ...>
```

10.2 Profile 6/1

10.2.1 Physical layer

Table 301 specifies the PhL selection within IEC 61158-2.

Table 301 – CPF 6: PhL selection

Clause	Header	Presence	Constraints
1	Scope	YES	—
2	Normative references	Partial	Used if needed
3	Terms and definitions	—	
3.1	Common terms and definitions	Partial	Used if needed
3.2 – 3.6	—	NO	—
3.7	Type 8: Terms and definitions	YES	—
3.8 – 3.10	—	NO	—
4	Symbols and abbreviations	—	
4.1	Symbols	—	
4.1.1 – 4.1.5	—	NO	—
4.1.6	Type 8: Symbols	YES	—
4.1.7 – 4.1.9	—	NO	—
4.2	Abbreviations	—	
4.2.1 – 4.2.5	—	NO	—
4.2.6	Type 8: Additional abbreviations	YES	—
4.2.7 – 4.2.9	—	NO	—
5	Data-link – Physical Layer interface	—	
5.1	General	YES	—
5.2 – 5.6	—	NO	—
5.7	Type 8: Required services	YES	—
5.8 – 5.10	—	NO	—
6	Station Management – Physical Layer interface	—	
6.1	General	YES	—
6.2 – 6.5	—	NO	—
6.6	Type 8: Station Management – Physical Layer interface	YES	—
6.7 – 6.8	—	NO	—
7	DCE Independent Sublayer (DIS)	—	
7.1	General	YES	—
7.2 – 7.4	—	NO	—
7.5	Type 8: DIS	YES	—
7.6	—	NO	—
8	DTE – DCE interface	—	
8.1	General	YES	—
8.2 – 8.3	—	NO	—
8.4	Type 8: MIS — MDS Interface	YES	—
8.5	—	NO	—
9	Medium Dependent Sublayer (MDS)	—	
9.1	General	YES	—
9.2 – 9.7	—	NO	—
9.8	Type 8: MDS: Wire and optical media	YES	—
9.9 – 9.11	—	NO	—
10	MDS – MAU interface	—	
10.1	General	YES	—

Clause	Header	Presence	Constraints
10.2 – 10.5	—	NO	—
10.6	Type 8: MDS — MAU interface: Wire and optical media	YES	—
10.7 – 10.8			
11 – 26	—	NO	—
27	Type 8: Medium Attachment Unit: twisted-pair wire medium	YES	See Note 1
28	Type 8: Medium Attachment Unit: optical media	YES	See Note 1
Next clauses	—	NO	—
Annex A – L	—	NO	—
Annex M	(normative) Type 8: Connector specification	YES	See Note 2
Next annexes	—	NO	—
NOTE 1 The used MAU is selected at device level.			
NOTE 2 The used connector is selected at device level.			

10.2.2 Data-link layer

10.2.2.1 DLL service

10.2.2.1.1 DLL service selection

Data-link layer services are defined in IEC 61158-3-8. All clauses are included in communication profile 6/1 with the constraints specified in 10.2.2.1.2.

10.2.2.1.2 Assignment of DLL services to devices types

Table 302 defines the valid combinations of DLL services and their assignment to device types for profile 6/1.

Table 302 – CP 6/1: DLL service selection, assignment of DLL services to device types

DLL Services	Master		Slave			Bus coupler
	cyclic	cyclic and non cyclic	cyclic	non cyclic	cyclic and non cyclic	
CP identifier	618	619	611	612	613	614
DL services						
Put Buffer	M	M	O ^a	—	O ^a	—
Get Buffer	M	M	O ^b	—	O ^b	—
Buffer received	M	M	M	—	M	—
Normal data transfer	—	M	—	M	M	—
DL-management services						
Reset	M	M	M	M	M	M
Set value	M	M	O	O	O	O
Read value	M	M	O	O	O	O
Event	M	M	M	M	M	M
Get current configuration	M	M	—	—	—	—
Get active configuration	M	M	—	—	—	—
Set active configuration	M	M	—	—	—	—
^a A slave has to support Put Buffer if process data should be sent to the master. ^b A slave has to support Get Buffer if process data should be received from the master.						

10.2.2.2 DLL protocol

10.2.2.2.1 DLL protocol selection

Data-link layer protocols are defined in IEC 61158-4-8. All clauses are included in communication profile 6/1 with the constraints specified in 10.2.2.2.2.

NOTE The service primitives provision used depend on the supported device type services.

10.2.2.2.2 Constraints for MAC parameter data width

A master shall support data width as defined in Table 303.

To ensure interoperability slaves shall select their data width used from those supported mandatory by the master, see Table 303.

Table 303 – CPF 6: DLL protocol selection of data widths supported by master

Data Width	Master
0	M
1 bit	O
2 bits	M
4 bits	M
1 octet	M
12 bits	—
2 octets	M
3 octets	M
4 octets	M
6 octets	M
8 octets	M
10 octets	M
12 octets	M
14 octets	M
16 octets	M
18 octets	M
20 octets	M
24 octets	M
28 octets	M
32 octets	M
48 octets	M
52 octets	M
64 octets	M

A bus coupler shall support a data width of 0.

10.2.3 Application layer

10.2.3.1 AL service

10.2.3.1.1 AL service selection

Application layer services are defined in IEC 61158-5-8. All clauses are included in profile 6/1 with the constraints specified in 10.2.3.1.2, 10.2.3.1.3 and 10.2.3.1.4.

10.2.3.1.2 Supported data types

All supported data types listed in IEC 61158-5-8 are optional.

10.2.3.1.3 Assignment of AL services to devices types

The services provided depend on the device type. Table 304 defines the valid combinations of services and their assignment to device types.

Table 304 – CP 6/1: AL service selection, assignment of AL services to device types

ASE FAL Services	Master		Slave		
	cyclic	cyclic and non cyclic	cyclic	non cyclic	cyclic and non cyclic
CP identifier	618	619	611	612	613
Mgt ASE					
Get Attributes	—	M	—	M ^a	M ^a
AP ASE					
Identify	—	M	—	M	M
Get Status	—	M	—	O ^a	O ^a
Initiate	—	M	—	O ^a	O ^a
Terminate	—	M	—	O ^a	O ^a
Reject	—	M	—	M	M
AR ASE					
AR-Unconfirmed Send	M	M	M ^b	—	M ^b
AR-Establish	M	M	O	—	O
AR-Abort	M	M	O	—	O
AR-Data-Send- Acknowledge	—	—	—	—	—
Variable ASE					
Read	—	M	—	O	O
Write	—	M	—	O	O
Information Report	—	M	—	O	O
Function Invocation ASE					
Start	—	M	—	O	O
Stop	—	M	—	O	O
Resume	—	M	—	O	O
Reset	—	M	—	O	O
^a This service is not needed, if only pre-established ARs on this slave are used.					
^b Push publisher shall have the request primitive, push subscriber shall have the receive primitive.					

10.2.3.1.4 Variable ASE, use of variable specifier in services

Only “numeric identifier” shall be used as “variable specifier” for variable ASEs.

10.2.3.2 AL protocol selection

The application layer protocol is defined in IEC 61158-6-8. A device shall provide at least the necessary protocol options to fulfill the supported services.

10.3 Profile 6/2**10.3.1 Physical layer**

Profile 6/2 uses the same PhL clause selection from IEC 61158-2 as profile 6/1. The selection is specified in Table 301.

10.3.2 Data-link layer

10.3.2.1 DLL service

10.3.2.1.1 DLL service selection

Data-link layer services are defined in IEC 61158-3-8. All clauses are included in profile 6/2 with the constraints specified in 10.3.2.1.2.

10.3.2.1.2 Assignment of DLL services to devices types

Table 305 defines the valid combinations of DL services and their assignment to device types.

Table 305 – CP 6/2: DLL service selection, assignment of DLL services to device types

DLL Services	Master	Slave	
		non cyclic	cyclic and non cyclic
CP identifier	629	622	623
DL services			
Put Buffer	M	—	O ^a
Get Buffer	M	—	O ^b
Buffer received	M	—	M
Normal data transfer	M	M	M
DL-management services			
Reset	M	M	M
Set value	M	M	M
Read value	M	M	M
Event	M	M	M
Get current configuration	M	—	—
Get active configuration	M	—	—
Set active configuration	M	—	—
^a A slave has to support Put Buffer if process data should be send to the master.			
^b A slave has to support Get Buffer if process data should be received from the master.			
NOTE Slaves with cyclic data exchange only are defined in profile 6/1.			

10.3.2.2 DLL protocol

10.3.2.2.1 DLL protocol selection

Data-link layer protocols are defined in IEC 61158-4-8. All clauses are included in communication profile 6/1 with the constraints specified in 10.3.2.2.2.

NOTE The service primitives provision used depend on the supported device type services.

10.3.2.2.2 Constraints for MAC parameter data width

A master shall support data width as defined in Table 303.

To ensure interoperability slaves shall select their data width used from those supported mandatory by the master, see Table 303.

10.3.3 Application layer

10.3.3.1 AL service

10.3.3.1.1 AL service selection

Application layer services are defined in IEC 61158-5-8. All clauses are included in profile 6/2 with the constraints specified in 10.3.3.1.2, 10.3.3.1.3, 10.3.3.1.4 and 10.3.3.1.5.

10.3.3.1.2 Supported data types

All supported data types listed in IEC 61158-5-8 are optional.

10.3.3.1.3 Assignment of AL services to devices types

The services provided depend on the device type. Table 306 defines the valid combinations of services and their assignment to device types.

Table 306 – CP 6/2: AL service selection, assignment of AL services to device types

ASE FAL Services	Master	Slave	
		non cyclic	cyclic and non cyclic
CP identifier	629	622	623
Mgt ASE			
Get Attributes	M	M ^a	M ^a
AP ASE			
Identify	M	M	M
Get Status	M	O ^a	O ^a
Initiate	M	O ^a	O ^a
Terminate	M	O ^a	O ^a
Reject	M	M	M
AR ASE			
AR-Unconfirmed Send	M	—	M ^b
AR-Establish	M	—	O
AR-Abort	M	—	O
AR-Data-Send-Acknowledge	M	M	M
Variable ASE			
Read	M	O	O
Write	M	O	O
Information Report	M	O	O
Function Invocation ASE			
Start	M	O	O
Stop	M	O	O
Resume	M	O	O
Reset	M	O	O
^a This service is not needed, if only pre-established ARs on this slave are used.			
^b Push publisher shall have the request primitive, push subscriber shall have the receive primitive.			
NOTE Slaves with cyclic data exchange only are defined in profile 6/1.			

10.3.3.1.4 Variable ASE, use of variable specifiers in services

Only “numeric identifier” shall be used as “variable specifier” for variable ASEs.

10.3.3.1.5 AR-Data-Send-Acknowledge, use of parameter for TCP/UDP/IP PDUs

AR-Data-Send-Acknowledge parameters values for use with TCP/IP are shown in Table 307.

Table 307 – CP 6/2: AL service selection of AR-Data-Send-Acknowledge service parameters

Parameter name	Constraints
Destination Address	—
Source Address	—
Destination Node	0 or 2
Source Node	0 or 2
Destination Subnode	10 for TCP/IP
Source Subnode	10 for TCP/IP
Protocol Code	1 := TCP/IP
Block Number	00 := no segmentation 01 := first segment 02 – 254 := further segments 255 := last segment

10.3.3.2 AL protocol selection

The application layer protocol is defined in IEC 61158-6-8. Profile 6/2 uses the same protocol selections as profile 6/1 (see 10.2.3.2).

10.4 Profile 6/3**10.4.1 Physical layer**

Profile 6/3 uses the same PhL clause selection from IEC 61158-2 as profile 6/1. The selection is specified in Table 301.

10.4.2 Data-link layer**10.4.2.1 DLL service****10.4.2.1.1 DLL service selection**

Data-link layer services are defined in IEC 61158-3-8. All clauses are included in communication profile 6/1 with the constraints specified in 10.4.2.1.2.

10.4.2.1.2 Assignment of DLL services to devices types

Table 308 defines the valid combinations of DL services and their assignment to device types.

Table 308 – CP 6/3: DLL service selection, assignment of DLL services to device types

DLL Services	Master	Slave	
		non cyclic	cyclic and non cyclic
CP identifier	639	632	633
DL services			
Put Buffer	M	—	O ^a
Get Buffer	M	—	O ^b
Buffer received	M	—	M
Normal data transfer	M	M	M
DL-management services			
Reset	M	M	M
Set value	M	M	M
Read value	M	M	M
Event	M	M	M
Get current configuration	M	—	—
Get active configuration	M	—	—
Set active configuration	M	—	—
^a A slave has to support Put Buffer if process data should be send to the master.			
^b A slave has to support Get Buffer if process data should be received from the master.			
NOTE Slaves with cyclic data exchange only are defined in profile 6/1.			

10.4.2.2 DLL protocol

10.4.2.2.1 DLL protocol selection

Data-link layer protocols are defined in IEC 61158-4-8. All clauses are included in communication profile 6/1 with the constraints specified in 10.4.2.2.2.

NOTE The service primitives provision used depend on the supported device type services.

10.4.2.2.2 Constraints for MAC parameter data width

A master shall support data width as defined in Table 303. To ensure interoperability slaves shall select their data width used from those supported mandatory by the master, see Table 303.

10.4.3 Application layer

10.4.3.1 AL service

10.4.3.1.1 AL service selection

Application layer services are defined in IEC 61158-5-8. All clauses are included in profile 6/3 with the constraints specified in 10.4.3.1.2, 10.4.3.1.3, 10.4.3.1.4.

10.4.3.1.2 Supported data types

All supported data types listed in IEC 61158-5-8 are optional.

10.4.3.1.3 Assignment of AL services to devices types

The services provided depend on the device type. Table 309 defines the valid combinations of services and their assignment to device types.

Table 309 – CP 6/3: AL service selection, assignment of AL services to device types

ASE FAL Services	Master	Slave	
		non cyclic	cyclic and non cyclic
CP identifier	639	632	633
Mgt ASE			
Get Attributes	—	—	—
AP ASE			
Identify	—	—	—
Get Status	—	—	—
Initiate	—	—	—
Terminate	—	—	—
Reject	M	M	M
AR ASE			
AR-Unconfirmed Send	M	—	M ^a
AR-Establish	M	—	O
AR-Abort	M	—	O
AR-Data-Send-Acknowledge	M	O	O
Variable ASE			
Read	M	M	M
Write	M	O	O
Information Report	M	O	O
Function Invocation ASE			
Start	—	—	—
Stop	—	—	—
Resume	—	—	—
Reset	—	—	—
^a Push publisher shall have the request primitive, push subscriber shall have the receive primitive.			
NOTE Slaves with cyclic data exchange only are defined in profile 6/1.			

10.4.3.1.4 Variable ASE, use of variable specifiers in services

Only “numeric identifier” shall be used as “variable specifier” for variable ASEs.

10.4.3.2 AL protocol selection

The Application layer protocol is defined in IEC 61158-6-8. A device shall provide at least the necessary protocol options to fulfill the supported services.

11 Communication Profile Family 7 – Void

NOTE This clause is a placeholder in this edition to minimize the disruption to existing national and multi-national standards and consortia documents that reference the subclause numbering of the prior edition.

12 Communication Profile Family 8 (CC-Link¹³)

12.1 General overview

12.1.1 General

Communication Profile Family 8 (CPF8) defines communication profiles based on IEC 61158-2 type 18, IEC 61158-3-18, IEC 61158-4-18, IEC 61158-5-18 and IEC 61158-6-18, which corresponds to parts of the communication systems commonly known as CC-Link.

CPF 8 consists of three profile sets:

- a) Profile 8/1 – CC-Link/V1
- b) Profile 8/2 – CC-Link/V2
- c) Profile 8/3 – CC-Link/LT

Common to all CPF 8 profiles, there are two fundamental device types defined: Master devices and Slave devices.

Master devices determine the data communication on the bus; only a Master device is able to initiate transmissions on the bus.

Slave devices are field devices such as I/O devices, valves, drives and measuring transducers. Slave devices are assigned to a Master device as a provider for cyclic I/O data exchange, and optionally, acyclic messaging. A Slave device is not able to initiate transmissions on the bus, it only responds to requests from a Master device.

Each device is considered a station and is identified on the network by its station identifier. The addressing space for devices on the network is mapped as sequential numbers called slot identifiers. A device is configured to occupy one or more slots as specified by its station identifier (the first slot occupied) and its number of occupied slots (sequentially numbered slots in the network's address space).

12.1.2 Profile 8/1

CP 8/1 defines a transmission method named Polled which uses the:

polled response access protocol — the transmission of data managed by the process of a Master individually interrogating each Slave in sequence called scanning. A Slave device transmits a response immediately upon receipt of an explicitly coded poll request addressed to the Slave station from the Master station.

There are three fundamental types of Slave station specified, each identified by their transmission support level as shown in Table 310.

¹³ CC-Link Logo is the registered trademark of CC-Link Partners Association (CLPA). CLPA is a non-profit trade organization to support the fieldbus CC-Link. This information is given for the convenience of users of this document and does not constitute an endorsement by IEC of the trademark holder or any of its products. Compliance to this profile does not require use of the registered trademark. Use of the registered trademark CC-Link Logo requires permission of the trade name holder.

Table 310 – CP 8/1 transmission support level

Transmission support level	Commonly named Slave device type	Bit-oriented cyclic	Word-oriented cyclic	Acyclic
A	Remote I/O station	YES	NO	NO
B	Remote device station	YES	YES	NO
C	Intelligent device station	YES	YES	YES

The PhL specifies a balanced transmission signal over a shielded 3-core twisted cable. Communication data rates as high as 10 mbps and transmission distances as long as 1 200 m are specified. CP 8/1 implements an MAU compliant with ISO/IEC 8482 Twisted Pair Multipoint Interconnections, and a derivative of ANSI TIA/EIA-485-A.

12.1.3 Profile 8/2

CP 8/2 is the same as CP 8/1 but adds segmenting capabilities to the cyclic data transfer, using a technique called extended frames. Devices that support this profile are labelled as compliant with CC-Link V2.

12.1.4 Profile 8/3

CP 8/3 defines a transmission method named Packed which uses the:

packed response access protocol — the transmission of data managed by the process of a Master broadcasting a trigger message whereupon each Slave waits a time period unique to its station identifier then transmits its response. This results in a time-sliced packed response frame from all Slaves triggered by a single Master request.

The PhL is a powered-bus that specifies a balanced transmission signal over a 4-core unshielded cable in both flat and round configurations with conductors specified for communications signal as well as network-embedded power distribution.

Communication data rates as high as 2,5 mbps and transmission distances as long as 500 m are specified. CP 8/3 implements a MAU compliant with ISO/IEC 8482 Twisted Pair Multipoint Interconnections, and is a derivative of ANSI TIA/EIA-485-A.

12.2 Profile 8/1

12.2.1 Physical layer

Table 311 specifies the PhL selection within IEC 61158-2 for devices of all types of this profile.

Table 311 – CP 8/1 PhL selection

Clause	Header	Presence	Constraints
5.10	Type 18: Required services	YES	—
6.8	Type 18: Systems management – PhL interface	YES	—
9.11	Type 18: MDS	YES	—
10.7	Type 18: MDS – MAU interface	YES	—
31	Type 18: Medium attachment unit: basic medium	YES	—
32	Type 18: Medium attachment unit: powered medium	NO	—
Q	Type 18: Connector specifications	NO	—
R	Type 18: Media cable specifications	—	—
R.1	Type 18-PhL-B cable	YES	—
R.2	Type 18-PhL-P cable	NO	—

12.2.2 Data-link layer

12.2.2.1 DLL services

Table 312 specifies the DLL services selection within IEC 61158-3-18 for devices of all types of this profile.

Table 312 – CP 8/1 DLL services selection

Clause	Header	Presence	Constraints
3	Terms, definitions, symbols, abbreviations and conventions	YES	—
4	Data-link services	—	—
4.1	Overview	YES	—
4.2	Primitives of the DLS	YES	—
4.3	CYCLIC-DATA-UPDATE	—	—
4.3.1	Parameters	YES	—
4.3.2	Master-polled	Partial	Used in Master type devices
4.3.3	Slave-polled	Partial	Used in Slave type devices
4.3.4	Master-packed	NO	—
4.3.5	Slave-packed	NO	—
4.4	ACYCLIC-DATA-TRANSMIT	—	—
4.4.1	Parameters	YES	—
4.4.2	Master-polled	Partial	Used in Master type devices
4.4.3	Slave-polled	Partial	Used in transmission support level C Slave type devices
4.5	MASTER-TRANSMISSION-TRIGGER	Partial	Used in Master type devices
5	DL-management Services	—	—
5.1	Overview	YES	—
5.2	Required services	YES	—
5.3	ESTABLISH-MASTER-POLLED	Partial	Used in Master type devices
5.4	ESTABLISH-SLAVE-POLLED	Partial	Used in Slave type devices
5.5	ESTABLISH-MASTER-PACKED	NO	—
5.6	ESTABLISH-SLAVE-PACKED	NO	—
5.7	RELEASE-CONNECTION	YES	—
5.8	SUSPEND-CONNECTION	YES	—
5.9	RESUME-CONNECTION	YES	—
5.10	ACTIVATE-STANDBY-MASTER	Partial	Used in Master type devices with standby Master status
5.11	ERROR	YES	—

12.2.2.2 DLL protocol

Table 313 specifies the DLL protocol selection within IEC 61158-4-18 for devices of all types of this profile.

Table 313 – CP 8/1 DLL protocol selection

Clause	Header	Presence	Constraints
3	Terms, definitions, symbols, abbreviations and conventions	YES	—
4	DL-protocol overview	YES	—
4.1	Introduction	YES	—
4.2	Polled DLE classes	YES	—
4.3	Packed DLE classes	NO	—
5	Type 18: DLPDU encoding and transmission	—	—
5.1	DL – PhL interface	YES	—
5.2	DLPDU transmission encoding	—	—
5.2.1	General	YES	—
5.2.2	Polled DLE	YES	—
5.2.3	Packed DLE	NO	—
5.2.4	HDLC conventions	YES	—
5.2.5	HDLC exceptions	YES	—
5.2.6	Error handling	YES	—
6	DLPDU – basic structure	—	—
6.1	Overview	YES	—
6.2	Address field	—	—
6.2.1	Master-polled DLE generated address field	Partial	Used in Master type devices
6.2.2	Slave-polled DLE generated address field	Partial	Used in Slave type devices
6.2.3	Master-packed DLE generated address field	NO	—
6.2.4	Slave-packed DLE generated address field	NO	—
6.3	Status field	—	—
6.3.1	Master-polled DLE generated status field	Partial	Used in Master type devices
6.3.2	Slave-polled DLE generated status field	Partial	Used in Slave type devices
6.3.3	Master-packed DLE generated status field	NO	—
6.3.4	Slave-packed DLE generated status field	NO	—
6.4	Data field	—	—
6.4.1	Master-polled DLE generated data field	YES	—
6.4.1.1	Overview	YES	—
6.4.1.2	Bit-oriented cyclic data field	YES	—
6.4.1.3	Word-oriented cyclic data field	YES	Used in transmission support level B and C Slave type devices
6.4.1.4	Acyclic data field	Partial	Used in transmission support level C Slave type devices
6.4.2	Slave-polled DLE generated data field	—	—
6.4.2.1	Overview	YES	—
6.4.2.2	Bit-oriented cyclic data field	YES	—

Clause	Header	Presence	Constraints
6.4.2.3	Word-oriented cyclic data field	Partial	Used in transmission support level B and C Slave type devices
6.4.2.4	Acyclic data field	Partial	Used in transmission support level C Slave type devices
6.4.3	Master-packed DLE generated data field	NO	—
6.4.4	Slave-packed DLE generated data field	NO	—
7	DLPDU – Detailed structure, segmenting and reassembly	—	—
7.1.1	Overview	YES	—
7.1.2	Cyclic data	—	—
7.1.2.1	Contiguous polled DLE cyclic data field	YES	—
7.1.2.2	Segmented polled DLE cyclic data field	NO	—
7.1.2.3	Packed DLE cyclic data field	NO	—
7.1.3	Acyclic data	Partial	Used in transmission support level C type devices
8	Data transmission methods	—	—
8.1	Overview	YES	—
8.2	Master-polled method	Partial	Used in Master type devices
8.3	Level A slave-polled method	Partial	Used in Slave type devices
8.4	Level B slave-polled method	Partial	Used in transmission support level B and C Slave type devices
8.5	Level C slave-polled method	Partial	Used in transmission support level C Slave type devices
8.6	Master-packed method	NO	—
8.7	Slave-packed method	NO	—
9	DL-management – procedures	—	—
9.1	Overview	YES	—
9.2	Establish master-polled DLE procedure	Partial	Used in Master type devices
9.3	Establish slave-polled DLE procedure	Partial	Used in Slave type devices
9.4	Establish master-packed DLE procedure	NO	—
9.5	Establish slave-packed DLE procedure	NO	—
9.6	Release connection procedure	YES	—
9.7	Suspend connection procedure	YES	—
9.8	Resume connection procedure	YES	—
9.9	Activate standby Master procedure	Partial	Used in Master type devices with standby Master status

12.2.3 Application layer

12.2.3.1 AL services

Table 314 specifies the AL services selection within IEC 61158-5-18 for devices of all types of this profile.

Table 314 – CP 8/1 AL services selection

Clause	Header	Presence	Constraints
1	Scope	YES	—
2	Normative references	YES	—
3	Terms, definitions, abbreviations, and conventions	YES	—
4	Concepts	YES	—
5	Data type ASE	YES	—
6	Communication model specification	—	—
6.1	General	YES	—
6.2	ASEs	—	—
6.2.1	Management ASE	—	—
6.2.1.1	Overview	YES	—
6.2.1.2	Management class specification	YES	—
6.2.1.3	Management ASE service specifications	—	—
6.2.1.3.1	Get service	YES	—
6.2.1.3.2	Set service	YES	—
6.2.1.3.3	Error indication	YES	—
6.2.1.3.4	Connect service	YES	—
6.2.1.3.5	Disconnect service	YES	—
6.2.1.3.6	Start scan service	Partial	Used in Master type devices
6.2.1.3.7	Stop scan service	Partial	Used in Master type devices
6.2.1.4	M1 device manager class specification	Partial	Used in Master type devices
6.2.1.5	M2 device manager class specification	NO	—
6.2.1.6	S1 device manager class specification	Partial	Used in Slave type devices
6.2.1.7	S2 device manager class specification	NO	—
6.3	ARs	—	—
6.3.1	Overview	YES	—
6.3.2	Connection management	—	—
6.3.2.1	M1 connection manager class	Partial	Used in Master type devices
6.3.2.2	M2 connection manager class	NO	—
6.3.2.3	S1 connection manager class	Partial	Used in Slave type devices
6.3.2.4	S2 connection manager class	NO	—
6.3.3	Process Data AR ASE	YES	—
6.3.4	M1 cyclic transmission class specification	Partial	Used in Master type devices
6.3.5	M2 cyclic transmission class specification	NO	—
6.3.6	S1 cyclic transmission class specification	Partial	Used in Slave type devices
6.3.7	S2 cyclic transmission class specification	NO	—
6.3.8	Acyclic transmission class specification	Partial	Used in Master type and transmission support level C Slave type devices

12.2.3.2 AL protocol

Table 315 specifies the AL protocol selection within IEC 61158-6-18 for devices of all types of this profile.

Table 315 – CP 8/1 AL protocol selection

Clause	Header	Presence	Constraints
1	Scope	YES	—
2	Normative references	YES	—
3	Terms and definitions	YES	—
4	Abstract syntax	—	—
4.1	M1 device manager PDU abstract syntax	Partial	Used in Master type devices
4.2	M2 device manager PDU abstract syntax	NO	—
4.3	S1 device manager PDU abstract syntax	Partial	Used in Slave type devices
4.4	S2 device manager PDU abstract syntax	NO	—
4.5	M1 connection manager PDU abstract syntax	Partial	Used in Master type devices
4.6	M2 connection manager PDU abstract syntax	NO	—
4.7	S1 connection manager PDU abstract syntax	Partial	Used in Slave type devices
4.8	S2 connection manager PDU abstract syntax	NO	—
4.9	M1 cyclic transmission PDU abstract syntax	Partial	Used in Master type devices
4.10	M2 cyclic transmission PDU abstract syntax	NO	—
4.11	S1 cyclic transmission PDU abstract syntax	Partial	Used in Slave type devices
4.12	S2 cyclic transmission PDU abstract syntax	NO	—
4.13	Acyclic transmission PDU abstract syntax	Partial	Used in transmission support level C type devices
5	Transfer syntax	—	—
5.1	M1 device manager PDU encoding	Partial	Used in Master type devices
5.2	M2 device manager PDU encoding	NO	—
5.3	S1 device manager PDU encoding	Partial	Used in Slave type devices
5.4	S2 device manager PDU encoding	NO	—
5.5	M1 connection manager PDU encoding	Partial	Used in Master type devices
5.6	M2 connection manager PDU encoding	NO	—
5.7	S1 connection manager PDU encoding	Partial	Used in Slave type devices
5.8	S2 connection manager PDU encoding	NO	—
5.9	M1 cyclic transmission PDU encoding	Partial	Used in Master type devices
5.10	M2 cyclic transmission PDU encoding	NO	—
5.11	S1 cyclic transmission PDU encoding	Partial	Used in Slave type devices
5.12	S2 cyclic transmission PDU encoding	NO	—
5.13	Acyclic transmission PDU encoding	Partial	Used in transmission support level C type devices
6	Structure of FAL protocol state machines	YES	—
7	AP-Context state machine	YES	—
8	FAL Service Protocol Machine (FSPM)	YES	—
9	AR Protocol Machine (ARPM)	—	—
9.1	Overview	YES	—
9.2	M1 Master ARPM	Partial	Used in Master type devices
9.3	M2 Master ARPM	NO	—
9.4	Slave ARPM	Partial	Used in Slave type devices
10	DLL Mapping Protocol Machine (DMPM)	YES	—

12.3 Profile 8/2

12.3.1 Physical layer

Profile 8/2 uses the same PhL selection from IEC 61158-2 as profile 8/1. Table 311 specifies the subclauses included in this profile.

12.3.2 Data-link layer

12.3.2.1 DLL services

Profile 8/2 uses the same DLL services selection from IEC 61158-3-18 as profile 8/1. Table 312 specifies the subclauses included in this profile.

12.3.2.2 DLL protocol

Profile 8/2 uses the same DLL protocol selection from IEC 61158-4-18 as profile 8/1 with the exceptions noted in Table 316.

Table 316 – CP 8/2 DLL protocol selection

Clause	Header	Presence	Constraints
1 – 6	Same as CP 8/1		
7	Type 18: DLPDU – Detailed structure, segmenting and reassembly	—	—
7.1.1	Overview	YES	—
7.1.2	Cyclic data	—	—
7.1.2.1	Contiguous polled DLE cyclic data field	NO	—
7.1.2.2	Segmented polled DLE cyclic data field	YES	—
7.1.2.3	Packed DLE cyclic data field	NO	—
7.1.3	Acyclic data	Partial	Used in transmission support level C type devices
8 – 9	Same as CP 8/1		

12.3.3 Application layer

12.3.3.1 AL services

Profile 8/2 uses the same AL services selection from IEC 61158-5-18 as profile 8/1. Table 314 specifies the subclauses included in this profile.

12.3.3.2 AL protocol

Profile 8/2 uses the same AL protocol selection from IEC 61158-6-18 as profile 8/1. Table 315 specifies the subclauses included in this profile.

12.4 Profile 8/3

12.4.1 Physical layer

Table 317 specifies the PhL selection within IEC 61158-2 for devices of all types of this profile.

Table 317 – CP 8/3 PhL selection

Clause	Header	Presence	Constraints
5.10	Type 18: Required services	YES	—
6.8	Type 18: Systems management – PhL interface	YES	—
9.11	Type 18: MDS	YES	—
10.7	Type 18: MDS – MAU interface	YES	—
31	Type 18: Medium attachment unit: basic medium	NO	—
32	Type 18: Medium attachment unit: powered medium	YES	—
Q	Type 18: Connector specifications	YES	—
R	Type 18: Media cable specifications	—	—
R.1	Type 18-PhL-B cable	NO	—
R.2	Type 18-PhL-P cable	YES	—

12.4.2 Data-link layer

12.4.2.1 DLL services

Table 318 specifies the DLL services selection within IEC 61158-3-18 for devices of all types of this profile.

Table 318 – CP 8/3 DLL services selection

Clause	Header	Presence	Constraints
3	Terms, definitions, symbols, abbreviations and conventions	YES	—
4	Data-link services	—	—
4.1	Overview	YES	—
4.2	Primitives of the DLS	YES	—
4.3	CYCLIC-DATA-UPDATE	—	—
4.3.1	Parameters	YES	—
4.3.2	Master-polled	NO	—
4.3.3	Slave-polled	NO	—
4.3.4	Master-packed	Partial	Used in Master type devices
4.3.5	Slave-packed	Partial	Used in Slave type devices
4.4	ACYCLIC-DATA-TRANSMIT	NO	—
4.5	MASTER-TRANSMISSION-TRIGGER	NO	—
5	DL-management Services	—	—
5.1	Overview	YES	—
5.2	Required services	YES	—
5.3	ESTABLISH-MASTER-POLLED	NO	—
5.4	ESTABLISH-SLAVE-POLLED	NO	—
5.5	ESTABLISH-MASTER-PACKED	Partial	Used in Master type devices
5.6	ESTABLISH-SLAVE-PACKED	Partial	Used in Slave type devices
5.7	RELEASE-CONNECTION	YES	—
5.8	SUSPEND-CONNECTION	Partial	Used in Slave type devices
5.9	RESUME-CONNECTION	Partial	Used in Slave type devices
5.10	ACTIVATE-STANDBY-MASTER	NO	—
5.11	ERROR	YES	—

12.4.2.2 DLL protocol

Table 319 specifies the DLL protocol selection within IEC 61158-4-18 for devices of all types of this profile.

Table 319 – CP 8/3 DLL protocol selection

Clause	Header	Presence	Constraints
3	Terms, definitions, symbols, abbreviations and conventions	YES	—
4	DL-protocol overview	YES	—
4.1	Introduction	YES	—
4.2	Polled DLE classes	NO	—
4.3	Packed DLE classes	YES	—
5	DLPDU encoding and transmission	—	—
5.1	DL – PhL interface	YES	—
5.2	DLPDU transmission encoding	—	—
5.2.1	General	YES	—
5.2.2	Polled DLE	NO	—
5.2.3	Packed DLE	YES	—
5.2.4	HDLC conventions	YES	—
5.2.5	HDLC exceptions	YES	—
5.2.6	Error handling	YES	—
6	DLPDU – basic structure	—	—
6.1	Overview	YES	—
6.2	Address field	—	—
6.2.1	Master-polled DLE generated address field	NO	—
6.2.2	Slave-polled DLE generated address field	NO	—
6.2.3	Master-packed DLE generated address field	Partial	Used in Master type devices
6.2.4	Slave-packed DLE generated address field	Partial	Used in Slave type devices
6.3	Status field	—	—
6.3.1	Master-polled DLE generated status field	NO	—
6.3.2	Slave-polled DLE generated status field	NO	—
6.3.3	Master-packed DLE generated status field	Partial	Used in Master type devices
6.3.4	Slave-packed DLE generated status field	Partial	Used in Slave type devices
6.4	Data field	—	—
6.4.1	Master-polled DLE generated data field	NO	—
6.4.2	Slave-polled DLE generated data field	NO	—
6.4.3	Master-packed DLE generated data field	Partial	Used in Master type devices
6.4.4	Slave-packed DLE generated data field	Partial	Used in Slave type devices
7	DLPDU – Detailed structure, segmenting and reassembly	—	—
7.1.1	Overview	YES	—
7.1.2	Cyclic data	—	—
7.1.2.1	Contiguous polled DLE cyclic data field	NO	—
7.1.2.2	Segmented polled DLE cyclic data field	NO	—
7.1.2.3	Packed DLE cyclic data field	YES	—
7.1.3	Acyclic data	NO	—
8	Data transmission methods	—	—
8.1	Overview	YES	—
8.2	Master-polled method	NO	—

Clause	Header	Presence	Constraints
8.3	Level A slave-pollled method	NO	—
8.4	Level B slave-pollled method	NO	—
8.5	Level C slave-pollled method	NO	—
8.6	Master-packed method	Partial	Used in Master type devices
8.7	Slave-packed method	Partial	Used in Slave type devices
9	DL-management – procedures	—	—
9.1	Overview	YES	—
9.2	Establish master-pollled DLE procedure	NO	—
9.3	Establish slave-pollled DLE procedure	NO	—
9.4	Establish master-packed DLE procedure	Partial	Used in Master type devices
9.5	Establish slave-packed DLE procedure	Partial	Used in Slave type devices
9.6	Release connection procedure	YES	—
9.7	Suspend connection procedure	Partial	Used in Slave type devices
9.8	Resume connection procedure	Partial	Used in Slave type devices
9.9	Activate standby Master procedure	NO	—

12.4.3 Application layer

12.4.3.1 AL services

Table 320 specifies the AL services selection within IEC 61158-5-18 for devices of all types of this profile.

Table 320 – CP 8/3 AL services selection

Clause	Header	Presence	Constraints
1	Scope	YES	—
2	Normative references	YES	—
3	Terms, definitions, abbreviations, and conventions	YES	—
4	Concepts	YES	—
5	Data type ASE	YES	—
6	Communication model specification	—	—
6.1	General	YES	—
6.2	ASEs	—	—
6.2.1	Management ASE	—	—
6.2.1.1	Overview	YES	—
6.2.1.2	Management class specification	YES	—
6.2.1.3	Management ASE service specifications	—	—
6.2.1.3.1	Get service	YES	—
6.2.1.3.2	Set service	YES	—
6.2.1.3.3	Error indication	YES	—
6.2.1.3.4	Connect service	YES	—
6.2.1.3.5	Disconnect service	YES	—
6.2.1.3.6	Start scan service	NO	—
6.2.1.3.7	Stop scan service	NO	—
6.2.1.4	M1 device manager class specification	NO	—
6.2.1.5	M2 device manager class specification	Partial	Used in Master type devices
6.2.1.6	S1 device manager class specification	NO	—
6.2.1.7	S2 device manager class specification	Partial	Used in Slave type devices
6.3	ARs	—	—
6.3.1	Overview	YES	—
6.3.2	Connection management	—	—
6.3.2.1	M1 connection manager class	NO	—
6.3.2.2	M2 connection manager class	Partial	Used in Master type devices
6.3.2.3	S1 connection manager class	NO	—
6.3.2.4	S2 connection manager class	Partial	Used in Slave type devices
6.3.3	Process Data AR ASE	YES	—
6.3.4	M1 cyclic transmission class specification	NO	—
6.3.5	M2 cyclic transmission class specification	Partial	Used in Master type devices
6.3.6	S1 cyclic transmission class specification	NO	—
6.3.7	S2 cyclic transmission class specification	Partial	Used in Slave type devices
6.3.8	Acyclic transmission class specification	NO	—

12.4.3.2 AL protocol

Table 321 specifies the AL protocol selection within IEC 61158-6-18 for devices of all types of this profile.

Table 321 – CP 8/3 AL protocol selection

Clause	Header	Presence	Constraints
1	Scope	YES	—
2	Normative references	YES	—
3	Terms and definitions	YES	—
4	Abstract syntax	—	—
4.1	M1 device manager PDU abstract syntax	NO	—
4.2	M2 device manager PDU abstract syntax	Partial	Used in Master type devices
4.3	S1 device manager PDU abstract syntax	NO	—
4.4	S2 device manager PDU abstract syntax	Partial	Used in Slave type devices
4.5	M1 connection manager PDU abstract syntax	NO	—
4.6	M2 connection manager PDU abstract syntax	Partial	Used in Master type devices
4.7	S1 connection manager PDU abstract syntax	NO	—
4.8	S2 connection manager PDU abstract syntax	Partial	Used in Slave type devices
4.9	M1 cyclic transmission PDU abstract syntax	NO	—
4.10	M2 cyclic transmission PDU abstract syntax	Partial	Used in Master type devices
4.11	S1 cyclic transmission PDU abstract syntax	NO	—
4.12	S2 cyclic transmission PDU abstract syntax	Partial	Used in Slave type devices
4.13	Acyclic transmission PDU abstract syntax	NO	—
5	Transfer syntax	—	—
5.1	M1 device manager PDU encoding	NO	—
5.2	M2 device manager PDU encoding	Partial	Used in Master type devices
5.3	S1 device manager PDU encoding	NO	—
5.4	S2 device manager PDU encoding	Partial	Used in Slave type devices
5.5	M1 connection manager PDU encoding	NO	—
5.6	M2 connection manager PDU encoding	Partial	Used in Master type devices
5.7	S1 connection manager PDU encoding	NO	—
5.8	S2 connection manager PDU encoding	Partial	Used in Slave type devices
5.9	M1 cyclic transmission PDU encoding	NO	—
5.10	M2 cyclic transmission PDU encoding	Partial	Used in Master type devices
5.11	S1 cyclic transmission PDU encoding	NO	—
5.12	S2 cyclic transmission PDU encoding	Partial	Used in Slave type devices
5.13	Acyclic transmission PDU encoding	NO	—
6	Structure of FAL protocol state machines	YES	—
7	AP-Context state machine	YES	—
8	FAL Service Protocol Machine (FSPM)	YES	—
9	AR Protocol Machine (ARPM)	—	—
9.1	Overview	YES	—
9.2	M1 Master ARPM	NO	—
9.3	M2 Master ARPM	Partial	Used in Master type devices
9.4	Slave ARPM	Partial	Used in Slave type devices
10	DLL Mapping Protocol Machine (DMPM)	YES	—

13 Communication Profile Family 9 (HART^{®14})

13.1 General Overview

Communication Profile Family 9 defines a profile based on Type 20 elements in IEC 61158-2, IEC 61158-3-20, IEC 61158-4-20, IEC 61158-5-20, IEC 61158-6-20, and IEC 62591, which corresponds to parts of a communication system commonly known as the HART protocol and WirelessHART[®] protocol. There are two profiles. One is specified in this part of IEC 61784 and the second one is specified in IEC 62591.

Communication Profile Family 9 defines two profiles based on Type 20 elements in IEC 61158 and in IEC 62591:

- CP 9/1 also known as HART[®] and
- CP 9/2 also known as WirelessHART[®].

13.2 Profile 9/1, HART[®]

13.2.1 Physical layer

Table 322 specifies the PhL selection within IEC 61158-2 for devices of all types of this profile.

¹⁴ HART is the trademarks of HART Communication Foundation (HCF). HCF is a non-profit trade organization to support the HART Communication. This information is given for the convenience of users of this document and does not constitute an endorsement by IEC of the trademark holder or any of its products. Compliance to this profile does not require use of the registered trademark. Use of the trademark HART requires permission of the trade name holder.

Table 322 – CP 9/1 PhL selection

Clause	Header	Presence	Constraints
1	Scope	YES	—
2	Normative references	Partial	Relevant references only
3	Terms and definitions	—	—
3.1	Common terms and definitions	Partial	Relevant definitions only
3.2 – 3.9	—	NO	—
3.10	Type 20: Terms and definitions	YES	—
3.11	Type 24: Terms and definitions	NO	—
4	Symbols and abbreviations	—	—
4.1	Symbols	—	—
4.1.1 – 4.1.9	—	NO	—
4.1.10	Type 20: Symbols	YES	—
4.1.11	Type 24: Symbols	NO	—
4.2	Symbols	—	—
4.2.1 – 4.2.9	—	NO	—
4.2.10	Type 20: Abbreviations	YES	—
4.2.11	Type 24: Abbreviations	NO	—
5	DLL – PhL interface	—	—
5.1	General		—
5.2 – 5.10	—	NO	—
5.11	Type 20: Required services	YES	—
6 – 9	—	NO	—
9	Medium dependent sublayer (MDS)	—	—
10	MDS – MAU interface	NO	—
11 – 33	—	NO	—
34	Type 20: MDS – MAU interface: FSK medium	YES	—
Next clauses	—	NO	—
Annex A – S	—	NO	—
Annex T	Type 20: Network topology, cable characteristics and lengths, power distribution through barriers, and shielding and grounding	YES	—
Next annexes	—	NO	—

13.2.2 Data-link layer

13.2.2.1 DLL service selection

Table 326 specifies the DLL service selection within IEC 61158-3-20.

Table 323 – CP 9/1: DLL service selection

Clause	Header	Presence	Constraints
1	Scope	YES	—
2	Normative references	YES	—
3	Terms, definitions, symbols, abbreviations and conventions	YES	—
4	Type 20 Data-link layer services	YES	—

13.2.2.2 DLL protocol selection

Table 324 specifies the DLL protocol selection within IEC 61158-4-20.

Table 324 – CP 9/1: DLL protocol selection

Clause	Header	Presence	Constraints
1	Scope	YES	—
2	Normative references	YES	—
3	Terms, definitions, symbols and abbreviations	YES	—
4	Data-link layer protocol specification	YES	—

13.2.3 Application layer

13.2.3.1 AL service selection

Table 325 shows the application layer service selections from IEC 61158-5-20 for this profile.

Table 325 – CP 9/1: AL service selection

Clause	Header	Presence	Constraints
1	Scope	YES	—
2	Normative references	YES	—
3	Terms, definitions, symbols, abbreviations and conventions	YES	—
4	Concepts	YES	—
5	Data Type ASE	YES	—
6	Communication model specification	YES	—

13.2.3.2 AL protocol selection

Table 326 shows the application layer protocol selections from IEC 61158-6-20 for this profile.

Table 326 – CP 9/1: AL protocol selection

Clause	Header	Presence	Constraints
1	Scope	YES	—
2	Normative references	YES	—
3	Terms, definitions, symbols, abbreviations and conventions	YES	—
4	Abstract syntax	YES	—
5	Transfer syntax	YES	—
6	FAL state machines	YES	—
7	AP-Context state machines	YES	—
Annex A	Application process status	YES	—
Annex B	Device and dynamic variable	YES	—
Annex C	Common tables	YES	—
Annex D	Conformance and device revision	YES	—
Annex E	Command requirements	YES	The Universal Command set shall be implemented in all field devices.

13.3 Profile 9/2, WirelessHART®

The profile 9/2 is specified in IEC 62591, Clause 9.

14 Communication Profile Family 16 (SERCOS¹⁵)

14.1 General overview

Communication Profile Family 16 defines communication profiles based on IEC 61158-2 type 16, IEC 61158-3-16, IEC 61158-4-16, IEC 61158-5-16 and IEC 61158-6-16, and on IEC 61158-3-19, IEC 61158-4-19, IEC 61158-5-19 and IEC 61158-6-19, which collectively correspond to parts of a communication system commonly known as SERCOS interface.

- Profile 16/1 (SERCOS I)
This profile is based on fiber-media physical layers and operates at 2 and 4 Mbit/s (see 14.2).
- Profile 16/2 (SERCOS II)
This profile is similar to 16/1, but operates also at 8 and 16 Mbit/s, and provides for additional features (see 14.3).
- Profile 16/3 (SERCOS III)
This profile is based on ISO/IEC 8802-3 (Ethernet) MAC and physical layers; it provides again for additional features (see IEC 61784-2, 17.2).

14.2 Profile 16/1 (SERCOS I)

14.2.1 Physical layer selection

Table 327 specifies the PhL selection within IEC 61158-2 for this profile.

¹⁵ SERCOS is a trade name of sercos international e.V. This information is given for the convenience of users of this document and does not constitute an endorsement by IEC of the trademark holder or any of its products. Compliance to this profile does not require use of the registered trademark. Use of the trade name requires permission of the trade name holder.

Table 327 – CP 16/1: PhL selection

Clause	Header	Presence	Constraints
0	Introduction	YES	—
1	Scope	YES	—
2	Normative references	Partial	Used as needed
3	Terms and definitions	—	—
3.1	Common terms and definitions	Partial	Used when applicable
3.2 – 3.8	—	NO	—
3.9	Type 16: Terms and definitions	YES	—
4	Symbols and abbreviations	—	—
4.1	Symbols	—	—
4.1.1 – 4.1.7	—	NO	—
4.1.8	Type 16: Symbols	YES	—
4.2	Abbreviations	—	—
4.2.1 – 4.2.7	—	NO	—
4.2.8	Type 16: Abbreviations	YES	—
5	Data-link layer – physical layer interface	—	—
5.1	General	Partial	Used as needed
5.2 – 5.8	—	NO	—
5.2.9	Type 16: Required services	YES	—
6 – 8	—	NO	—
9	Medium dependent sublayer (MDS)	—	—
9.1	General	Partial	Used as needed
9.1 – 9.9	—	NO	—
9.10	Type 16: MDS: Wire and optical media	YES	—
10 – 29	MDS – MAU interface	NO	—
30	Medium attachment unit: optical fiber medium at 2, 4, 8 and 16 Mbit/s	YES	Used up to the exception below
30.2.3	Data rate	Partial	CP16/2 not used
Next clauses	—	NO	—
Annex A – M	—	NO	—
Annex N	Type 16: Connector specification	YES	—
Annex O	Type 16: Optical network topology	YES	—
Annex P	Type 16: Reference design examples	YES	—
Next annexes	—	NO	—

14.2.2 Data-link layer

14.2.2.1 DLL service selection

DLL services are defined in IEC 61158-3-16. IEC 61158-3-16 applies except 4.3.

14.2.2.2 DLL protocol selection

Table 328 specifies the DLL protocol selection within IEC 61158-4-16 for this profile.

Table 328 – CP 16/1: DLL protocol selection

Clause	Header	Presence	Constraints
Whole document	Data-link protocol specification (Type 16)	YES	Used up to the exceptions below
4.3	MDT DLPDU	—	—
4.3.1 – 4.3.4	—	YES	—
4.3.5	CP5	NO	Not used for CP16/1
4.3.6	CP6	NO	Not used for CP16/1
4.4	AT DLPDU	—	—
4.4.1 – 4.4.4	—	YES	—
4.4.5	CP5	NO	Not used for CP16/1
4.4.6	CP6	NO	Not used for CP16/1

14.2.3 Application layer

14.2.3.1 AL service selection

Table 329 specifies the AL service selection within IEC 61158-5-16 for this profile.

Table 329 – CP 16/1: AL service selection

Clause	Header	Presence	Constraints
Whole document	Application service specification (Type 16)	YES	Used up to the exceptions below
8.5	File transmission services	NO	Not used for CP16/1
9.2.10	FSP-FD	NO	Not used for CP16/1
9.2.11	FSP-FU	NO	Not used for CP16/1
10.2	Primitives received from the ARPM	Partial	ARP-FD and ARP-FU shall not be used for CP16/1

14.2.3.2 AL protocol selection

AL protocols are specified in IEC 61158-5-16. IEC 61158-5-16 applies except 4.5.3.3.10.

14.3 Profile 16/2 (SERCOS II)

14.3.1 Physical layer

Table 330 specifies the PhL selection within IEC 61158-2 for this profile.

Table 330 – CP 16/2: PhL selection

Clause	Header	Presence	Constraints
0	Introduction	YES	—
1	Scope	YES	—
2	Normative references	Partial	Used as needed
3	Terms and definitions	—	—
3.1	Common terms and definitions	Partial	Used when applicable
3.2 – 3.8	—	NO	—
3.9	Type 16: Terms and definitions	YES	—
4	Symbols and abbreviations	—	—
4.1	Symbols	—	—
4.1.1 – 4.1.7	—	NO	—
4.1.8	Type 16: Symbols	YES	—
4.2	Abbreviations	—	—
4.2.1 – 4.2.7	—	NO	—
4.2.8	Type 16: Abbreviations	YES	—
5	Data-link layer – Physical layer interface	—	—
5.1	General	Partial	Used as needed
5.2 – 5.8	—	NO	—
5.2.9	Type 16: Required services	YES	—
6 – 8	—	NO	—
9	Medium dependent sublayer (MDS)	—	—
9.1	General	Partial	Used as needed
9.1 – 9.9	—	NO	—
9.10	Type 16: MDS: Wire and optical media	YES	—
10 – 29	MDS – MAU interface	NO	—
30	Medium attachment unit: optical fiber medium at 2, 4, 8 and 16 Mbit/s	YES	—
Next clauses	—	NO	—
Annex A – Annex M	—	NO	—
Annex N	Type 16: Connector specification	YES	—
Annex O	Type 16: Optical network topology	YES	—
Annex P	Type 16: Reference design examples	YES	—
Annex Q – Annex R	—	NO	—
Next annexes	—	NO	—

14.3.2 Data-link layer

14.3.2.1 DLL service selection

DLL services are specified in IEC 61158-3-16.

14.3.2.2 DLL protocol selection

DLL protocols are specified in IEC 61158-4-16.

14.3.3 Application layer

14.3.3.1 AL service selection

AL services are specified in IEC 61158-5-16.

14.3.3.2 AL protocol selection

AL protocols are specified in IEC 61158-6-16.

15 Communication Profile Family 19 (MECHATROLINK¹⁶)

15.1 General overview

Communication Profile Family 19 defines communication profiles (CPs) based on IEC 61158-2 type 24, IEC 61158-3-24, IEC 61158-4-24, IEC 61158-5-24 and IEC 61158-6-24, and on other standards. (See Table 331.)

The CPF 19 (MECHATROLINK) consists of two distinct protocol sets, known generically (for historical reasons) as MECHATROLINK- II (M-II) for CP 19/1 and MECHATROLINK- III (M-III) for CP 19/2, which have main difference in their physical layers.

- Profile 19/1 (M-II): based on ANSI TIA/EIA-485-A PhL, which operates at 10 Mbps
- Profile 19/2 (M-III): based on ISO/IEC 8802-3 (Ethernet) PhL, which operates at 100 Mbps

Each CPs may be classified into more detailed profiles, based on another aspect of application process (AP) type or a sort of device type. Each AP types in a same CP play different roles in a same network as C1 master, C2 master and slave. Such detailed profiles are described in each subclause if needed.

Table 331 – CPF 19: overview of profile sets

Layer	Profile 19/1 (M-II)			Profile 19/2 (M-III)		
	C1 master	C2 master	Slave	C1 master	C2 master	Slave
Application	IEC 61158-5-24, IEC 61158-6-24			IEC 61158-5-24, IEC 61158-6-24		
Data link	IEC 61158-3-24, IEC 61158-4-24			IEC 61158-3-24, IEC 61158-4-24		
Physical	IEC 61158-2			IEC 61158-2 ISO/IEC 8802-3		

15.2 Profile 19/1 (MECHATROLINK-II)

15.2.1 Physical layer selection

Table 332 specifies the PhL selection within IEC 61158-2 for this profile.

¹⁶ MECHATROLINK™ is a trade name of YASKAWA ELECTRIC CORPORATION. This information is given for the convenience of users of this document and does not constitute an endorsement by IEC of the trade names holder or any of its products. Compliance to this profile does not require use of the trade names. Use of the trade name MECHATROLINK requires permission of the trade name holder.

Table 332 – CP 19/1 profile: PhL selection

Clause	Header	Presence	Constraints
1	Scope	YES	—
2	Normative reference	Partial	Used if needed
3	Terms and definitions	—	—
3.1	Common terms and definitions	Partial	Used when applicable
3.2 – 3.10	—	NO	—
3.11	Type 24: terms and definitions	YES	—
4	Symbols and abbreviations	—	—
4.1	Symbols	—	—
4.1.1 – 4.1.9	—	NO	—
4.1.10	Type 24: symbols	YES	—
4.2	Abbreviations	—	—
4.2.1 – 4.2.9	—	NO	—
4.2.n	Type 24: abbreviations	YES	—
5	DLL-PhL interface	—	—
5.1	General	Partial	Used when applicable
5.2 – 5.10	—	NO	—
5.11	Type 24: Required Service	YES	—
6	Systems management – PhL interface	—	—
6.1	General	Partial	Used when applicable
6.2 – 6.8	—	NO	—
6.9	Type 24: Systems management – PhL interface	YES	—
7	DCE independent sublayer (DIS)	NO	—
8	DTE – DCE interface and MIS-specific functions	NO	—
9	Medium dependent sublayer (MDS)	—	—
9.1	General	Partial	Used when applicable
9.2 – 9.11	—	NO	—
9.12	Type 24: MDS Twisted-pair wire	YES	—
10	MDS – MAU interface	—	—
10.1	General	Partial	Used when applicable
10.2 – 10.7	—	NO	—
10.8	Type 24: MDS – MAU interface: Twisted-pair wire medium	YES	—
11 – 32	—	NO	—
33	Type 24: Medium attachment unit: twisted-pair wire medium	YES	—
Next clauses	—	NO	—
Annex A – R	—	NO	—
Annex S	Type 24: Connector specification	—	—
S.1	Overview	Partial	Used when applicable
S.2	Type 24-1 connector	YES	—
S.3	Type 24-2 connector	NO	—
Next annexes	—	NO	—

15.2.2 Data-link layer

15.2.2.1 DLL service selection

15.2.2.1.1 Generic profile

Table 333 specifies the DLL service selection within IEC 61158-3-24 for this profile.

Table 333 – CP 19/1: DLL service selection

Clause	Header	Presence	Constraints
1	Scope	YES	—
2	Normative references	Partial	Used as needed
3	Terms, definitions, symbols, abbreviations and conventions	Partial	Used when applicable
4	Data-link service and concepts	—	—
4.1	Overview	YES	—
4.2	DLS-user services	—	—
4.2.1	General	YES	—
4.2.2	Write data	YES	—
4.2.3	Read data	YES	—
4.2.4	Send data with acknowledge service (SDA)	YES	Option
4.2.5	Send data with no acknowledge service (SDN)	NO	—
4.2.6	Event	YES	—
4.2.7	Get status	YES	—
4.3	Overview of interactions	YES	—
4.4	Detailed specification of services and interactions	—	—
4.4.1	Write data	YES	—
4.4.2	Read data	YES	—
4.4.3	Send data with acknowledge	YES	Option
4.4.4	Send data with no-acknowledge (SDN)	NO	—
4.4.5	Cyclic event	YES	—
5	DL-management service	—	—
5.1	Overview	—	—
5.1.1	General	YES	—
5.1.2	Reset	YES	—
5.1.3	Set value	YES	—
5.1.4	Get value	YES	—
5.1.5	Evaluate delay	NO	—
5.1.6	Set communication mode	NO	—
5.1.7	Start communication	YES	—
5.1.8	Clear error status	YES	—
5.1.9	DLM Event	YES	—
5.2	Overview of interactions	YES	—
5.3	Detailed specification of services and interactions	—	—
5.3.1	Reset	YES	—

Clause	Header	Presence	Constraints
5.3.2	Set value	YES	—
5.3.2.1	Function	YES	—
5.3.2.2	Types of parameters	—	—
5.3.2.2.1	General	YES	—
5.3.2.2.2	Var_ID	Partial	See 15.2.2.1.2 to 15.2.2.1.4
5.3.2.2.4	Result	YES	—
5.3.3	Get value	—	—
5.3.3.1	Function	YES	—
5.3.3.2	Types of parameters	YES	—
5.3.3.2.1	General	YES	—
5.3.3.2.2	Var_ID	Partial	See 15.2.2.1.2 to 15.2.2.1.4
5.3.3.2.3	Val	Partial	See 15.2.2.1.2 to 15.2.2.1.4
5.3.3.2.4	Result	YES	—
5.3.4	Evaluate delay	NO	—
5.3.5	Set communication mode	NO	—
5.3.6	Start communication	YES	—
5.3.7	DLM error event	YES	—

15.2.2.1.2 Detail for C1 master

Table 334 specifies DLL service selection within IEC 61158-3-24 for C1 master of CP 19/1.

Table 334 – DLL service selection for C1 master of CP 19/1

Clause	Header	Presence	Constraints
5.3.2.2.2	Var_ID	—	—
5.3.2.2.2.1	MA	YES	—
5.3.2.2.2.2	Nmax_slaves	YES	—
5.3.2.2.2.3	Cyc_sel	YES	—
5.3.2.2.2.4	Nmax_dly_cnt	NO	—
5.3.2.2.2.5	IO_sz	YES	—
5.3.2.2.2.6	Pkt_sz	YES	Option
5.3.2.2.2.7	Nmax_retry	YES	—
5.3.2.2.2.8	Tcycle	YES	—
5.3.2.2.2.9	Tslot	YES	—
5.3.2.2.2.10	Tunit	NO	—
5.3.2.2.2.11	Tidly	NO	—
5.3.2.2.2.12	Tc2_dly	NO	—
5.3.2.2.2.13	IO_Map	NO	—
5.3.2.2.3	Val	Partial	See Note
5.3.3.2.4	Result	Partial	See Note
NOTE Same as 5.3.2.2.2.1 to 5.3.2.2.2.13 in this table.			

15.2.2.1.3 Detail for C2 master

Table 335 specifies DLL service selection within IEC 61158-3-24 for C2 master of CP 19/1.

Table 335 – DLL service selection for C2 master of CP 19//1

Clause	Header	Presence	Constraints
5.3.2.2.2	Var_ID	—	—
5.3.2.2.2.1	MA	YES	—
5.3.2.2.2.2	Nmax_slaves	YES	—
5.3.2.2.2.3	Cyc_sel	YES	—
5.3.2.2.2.4	Nmax_dly_cnt	NO	—
5.3.2.2.2.5	IO_sz	YES	—
5.3.2.2.2.6	Pkt_sz	YES	Option
5.3.2.2.2.7	Nmax_retry	YES	—
5.3.2.2.2.8	Tcycle	YES	—
5.3.2.2.2.9	Tslot	YES	—
5.3.2.2.2.10	Tunit	NO	—
5.3.2.2.2.11	Tidly	NO	—
5.3.2.2.2.12	Tc2_dly	NO	—
5.3.2.2.2.13	IO_Map	NO	—
5.3.2.2.3	Val	Partial	See Note
5.3.3.2.4	Result	Partial	See Note
NOTE Same as 5.3.2.2.2.1 to 5.3.2.2.2.13 in this table.			

15.2.2.1.4 Detail for slave

Table 336 specifies DLL service selection within IEC 61158-3-24 for slave of CP 19/1.

Table 336 – DLL service selection for slave of CP 19//1

Clause	Header	Presence	Constraints
5.3.2.2.2	Var_ID	—	—
5.3.2.2.2.1	MA	YES	—
5.3.2.2.2.2	Nmax_slaves	NO	—
5.3.2.2.2.3	Cyc_sel	NO	—
5.3.2.2.2.4	Nmax_dly_cnt	NO	—
5.3.2.2.2.5	IO_sz	YES	—
5.3.2.2.2.6	Pkt_sz	YES	Option
5.3.2.2.2.7	Nmax_retry	YES	—
5.3.2.2.2.8	Tcycle	YES	—
5.3.2.2.2.9	Tslot	NO	—
5.3.2.2.2.10	Tunit	NO	—
5.3.2.2.2.11	Tidly	NO	—
5.3.2.2.2.12	Tc2_dly	NO	—
5.3.2.2.2.13	IO_Map	NO	—
5.3.2.2.3	Val	Partial	See Note
5.3.3.2.4	Result	Partial	See Note
NOTE Same as 5.3.2.2.2.1 to 5.3.2.2.2.13 in this table.			

15.2.2.2 DLL protocol selection

15.2.2.2.1 Generic profile

Table 337 specifies the DLL protocol selection within IEC 61158-4-24 for this profile.

Table 337 – CP 19/1: DLL protocol selection

Clause	Header	Presence	Constraints
1	Scope	YES	—
2	Normative references	Partial	Used as needed
3	Terms, definitions, symbols, abbreviations and conventions	Partial	Used when applicable
4	Overview of DL-protocol	—	—
4.1	Characteristic feature of DL-protocol	YES	—
4.2	DL layer component	YES	—
4.3	Timing sequence	—	—
4.3.1	Overview	YES	—
4.3.2	Cyclic transmission	—	—
4.3.2.1	Fixed-width time slot type	YES	—
4.3.2.2	Configurable time slot type	NO	—
4.3.2.3	Timing relationship between cyclic communication and data processing	YES	—
4.3.3	Acyclic transmission mode	NO	—
4.4	Service assumed from PhL	YES	—
4.5	Local parameters, variable, counters, timers	—	—
4.5.1	Overview	YES	—
4.5.2	Variables, parameters, counters and timers to support DLE function	Partial	See 15.2.2.2.2 and 15.2.2.2.4
5	DLPDU structure	—	—
5.1	Overview	YES	—
5.2	Basic format DLPDU structure	NO	—
5.3	Short format DLPDU structure	YES	—
6	DLE element procedure	—	—
6.1	Overview	YES	—
6.2	Cyclic transmission control sublayer	YES	—
6.2.1	General	YES	—
6.2.2	DLS-user interface	YES	—
6.2.3	Protocol machines in CTC	YES	—
6.2.3.1	Overview	YES	—
6.2.3.2	Cyclic transmission protocol machine	—	—
6.2.3.2.1	Protocol machine for cyclic communication consist of fixed-width time slot	Partial	See 15.2.2.2.2 and 15.2.2.2.4
6.2.3.2.2	Protocol machine for cyclic communication consist of configurable time slot	NO	—
6.2.3.2.3	Functions used by cyclic transmission machine	Partial	—
6.2.3.3	Message segmentation protocol machine	—	Option
6.2.3.3.1	General	YES	—
6.2.3.3.2	Segmentation for basic format DLPDU	NO	—
6.2.3.3.3	Segmentation for short format DLPDU	Partial	See 15.2.2.2.2 and 15.2.2.2.4
6.2.3.3.4	Functions used by message segmentation protocol machine	Partial	—
6.2.3.4	Acyclic transmission protocol machine	NO	—

Clause	Header	Presence	Constraints
6.2.4	CTC-DLM interface	YES	—
6.3	Send Receive Control	—	—
6.3.1	General	—	—
6.3.1.1	Send frame	YES	—
6.3.1.2	Receive frame	YES	—
6.3.1.3	Repeater or loopback of received frame	YES	Option
6.3.2	SRC-CTC interface	YES	—
6.3.3	Detailed specification of SRC	—	—
6.3.3.1	Overview	YES	—
6.3.3.2	Serializer	—	—
6.3.3.2.1	Internal architecture	YES	—
6.3.3.2.2	Behaviour	YES	—
6.3.3.2.2.1	Overview	YES	—
6.3.3.2.2.2	Serializer for basic format frame	NO	—
6.3.3.2.2.3	Serializer for short format frame	YES	—
6.3.3.3	Deserializer	—	—
6.3.3.3.1	Internal architecture	YES	—
6.3.3.3.2	Behaviour	—	—
6.3.3.3.2.1	Overview	YES	—
6.3.3.3.2.2	Deserializer for basic format frame	NO	—
6.3.3.3.2.3	Deserializer for short format frame	YES	—
6.3.3.4	Repeater	YES	Option
6.3.4	SRC-DLM interface	—	—
6.3.4.1	Overview	YES	—
6.3.4.2	Detailed definition of the services primitive and parameters	—	—
6.3.4.2.1	SRC_Reset	YES	—
6.3.4.2.2	SRC_Send_Frame	NO	—
6.3.4.2.3	SRC_Recv_Frame	NO	—
6.3.4.2.4	SRC_Enable_Loopback	NO	—
6.3.4.2.5	SRC_Err_Event	YES	—
7	DL management layer (DLM)	—	—
7.1	Overview	YES	—
7.2	Primitive definitions	YES	—
7.3	DLM protocol machine	Partial	See 15.2.2.2.2 and 15.2.2.2.4
7.4	Functions	Partial	—

15.2.2.2.2 Detail for C1 master

Table 338 specifies DLL protocol selection within IEC 61158-4-24 for C1 master of CP 19/1.

Table 338 – DLL protocol selection for C1 master of CP 19/1

Clause	Header	Presence	Constraints
4.5.2	Variables, parameters, counters and timers to support DLE function	—	—
4.5.2.1	V(MA), P(MA)	YES	—
4.5.2.2	V(Tcycle), P(Tcycle)	YES	—
4.5.2.3	V(Nmax_slaves), P(Nmax_slaves)	YES	—
4.5.2.4	V(Cyc_sel), P(Cyc_sel)	NO	—
4.5.2.5	V(Nmax_dly_cnt), P(Nmax_dly_cnt)	NO	—
4.5.2.6	V(IO_sz), P(IO_sz)	YES	—
4.5.2.7	V(Pkt_sz), P(Pkt_sz)	YES	Option
4.5.2.8	V(Nmax_retry), P(Nmax_retry)	YES	—
4.5.2.9	V(Tslot), P(Tslot)	YES	—
4.5.2.10	V(Tunit), P(Tunit)	NO	—
4.5.2.11	V(Tidly), P(Tidly)	NO	—
4.5.2.12	V(Tc2_dly), P(Tc2_dly)	NO	—
4.5.2.13	V(Tmsg), P(Tmsg)	NO	—
4.5.2.14	T(Twrpt)	NO	—
4.5.2.15	V(IO_MAP), P(IO_MAP)	NO	—
4.5.2.16	V(Sts_STI), P(Sts_STI)	NO	—
4.5.2.17	V(Sts_Err), P(Sts_Err)	YES	—
4.5.2.18	V(Fc2msg)	YES	—
4.5.2.19	V(Nslave)	YES	—
4.5.2.20	V(Nretry)	YES	—
4.5.2.21	V(Nrest_slot)	YES	—
4.5.2.22	V(Ndly_cnt)	NO	—
4.5.2.23	V(PDUType)	NO	—
4.5.2.24	V(SlotType)	YES	Option
4.5.2.25	V(Nms_1), V(Nms_2)	NO	—
4.5.2.26	V(Nmr_1), V(Nmr_2)	NO	—
4.5.2.27	V(Nmp_1), V(Nmp_2)	NO	—
4.5.2.28	V(Nmf_1), V(Nmf_2)	NO	—
4.5.2.29	V(Ten)	NO	—
4.5.2.30	V(Tdly)	NO	—
4.5.2.31	V(Tmax_dly)	NO	—
4.5.2.32	V(Tst)	NO	—
4.5.2.33	T(Tcycle)	YES	—
4.5.2.34	T(Tslot)	YES	—
4.5.2.35	T(Tmsg)	NO	—
4.5.2.36	T(Twrpt)	NO	—
4.5.2.37	Q(MSGc1s), Q(MSGc2s)	YES	—
4.5.2.38	Q(MSGc1r), Q(MSGc2r)	YES	—
6.2.3.2.1	Protocol machine for cyclic communication consist of fixed-width time slot	—	—
6.2.3.2.1.1	C1 master	YES	—

Clause	Header	Presence	Constraints
6.2.3.2.1.2	C2 master	NO	—
6.2.3.2.1.3	Slave	NO	—
6.2.3.3.2	Segmentation for short format DLPDU	YES	Option
7.3	DLM protocol machine	—	—
7.3.1	C1 master	YES	—
7.3.2	Slave and C2 master	NO	—

15.2.2.2.3 Detail for C2 master

Table 339 specifies DLL protocol selection within IEC 61158-4-24 for C2 master of CP 19/1.

Table 339 – DLL protocol selection for C2 master of CP 19/1

Clause	Header	Presence	Constraints
4.5.2	Variables, parameters, counters and timers to support DLE function	—	—
4.5.2.1	V(MA), P(MA)	YES	—
4.5.2.2	V(Tcycle), P(Tcycle)	YES	—
4.5.2.3	V(Nmax_slaves), P(Nmax_slaves)	YES	—
4.5.2.4	V(Cyc_sel), P(Cyc_sel)	NO	—
4.5.2.5	V(Nmax_dly_cnt), P(Nmax_dly_cnt)	NO	—
4.5.2.6	V(IO_sz), P(IO_sz)	YES	—
4.5.2.7	V(Pkt_sz), P(Pkt_sz)	YES	Option
4.5.2.8	V(Nmax_retry), P(Nmax_retry)	NO	—
4.5.2.9	V(Tslot), P(Tslot)	YES	—
4.5.2.10	V(Tunit), P(Tunit)	NO	—
4.5.2.11	V(Tidly), P(Tidly)	NO	—
4.5.2.12	V(Tc2_dly), P(Tc2_dly)	NO	—
4.5.2.13	V(Tmsg), P(Tmsg)	NO	—
4.5.2.14	T(Twrpt)	NO	—
4.5.2.15	V(IO_MAP), P(IO_MAP)	NO	—
4.5.2.16	V(Sts_STI), P(Sts_STI)	NO	—
4.5.2.17	V(Sts_Err), P(Sts_Err)	YES	—
4.5.2.18	V(Fc2msg)	YES	—
4.5.2.19	V(Nslave)	YES	—
4.5.2.20	V(Nretry)	NO	—
4.5.2.21	V(Nrest_slot)	NO	—
4.5.2.22	V(Ndly_cnt)	NO	—
4.5.2.23	V(PDUType)	NO	—
4.5.2.24	V(SlotType)	YES	Option
4.5.2.25	V(Nms_1), V(Nms_2)	NO	—
4.5.2.26	V(Nmr_1), V(Nmr_2)	NO	—
4.5.2.27	V(Nmp_1), V(Nmp_2)	NO	—
4.5.2.28	V(Nmf_1), V(Nmf_2)	NO	—
4.5.2.29	V(Ten)	NO	—

Clause	Header	Presence	Constraints
4.5.2.30	V(Tdly)	NO	—
4.5.2.3	V(Tmax_dly)	NO	—
4.5.2.32	V(Tst)	NO	—
4.5.2.33	T(Tcycle)	YES	—
4.5.2.34	T(Tslot)	YES	—
4.5.2.35	T(Tmsg)	NO	—
4.5.2.36	T(Twrpt)	NO	—
4.5.2.37	Q(MSGc1s), Q(MSGc2s)	NO	—
4.5.2.38	Q(MSGc1r), Q(MSGc2r)	NO	—
6.2.3.2.1	Protocol machine for cyclic communication consist of fixed-width time slot	—	—
6.2.3.2.1.1	C1 master	NO	—
6.2.3.2.1.2	C2 master	YES	—
6.2.3.2.1.3	Slave	NO	—
6.2.3.3.2	Segmentation for short format DLPDU	YES	Option
7.3	DLM protocol machine	—	—
7.3.1	C1 master	NO	—
7.3.2	Slave and C2 master	YES	—

15.2.2.2.4 Detail for slave

Table 340 specifies DLL protocol selection within IEC 61158-4-24 for slave of CP 19/1.

Table 340 – DLL protocol selection for slave of CP 19/1

Clause	Header	Presence	Constraints
4.5.2	Variables, parameters, counters and timers to support DLE function	—	—
4.5.2.1	V(MA), P(MA)	YES	—
4.5.2.2	V(Tcycle), P(Tcycle)	YES	—
4.5.2.3	V(Nmax_slaves), P(Nmax_slaves)	NO	—
4.5.2.4	V(Cyc_sel), P(Cyc_sel)	NO	—
4.5.2.5	V(Nmax_dly_cnt), P(Nmax_dly_cnt)	NO	—
4.5.2.6	V(IO_sz), P(IO_sz)	YES	—
4.5.2.7	V(Pkt_sz), P(Pkt_sz)	YES	Option
4.5.2.8	V(Nmax_retry), P(Nmax_retry)	NO	—
4.5.2.9	V(Tslot), P(Tslot)	NO	—
4.5.2.10	V(Tunit), P(Tunit)	NO	—
4.5.2.11	V(Tidly), P(Tidly)	NO	—
4.5.2.12	V(Tc2_dly), P(Tc2_dly)	NO	—
4.5.2.13	V(Tmsg), P(Tmsg)	NO	—
4.5.2.14	T(Twrpt)	NO	—
4.5.2.15	V(IO_MAP), P(IO_MAP)	NO	—
4.5.2.16	V(Sts_STI), P(Sts_STI)	NO	—
4.5.2.17	V(Sts_Err), P(Sts_Err)	YES	—
4.5.2.18	V(Fc2msg)	NO	—

Clause	Header	Presence	Constraints
4.5.2.19	V(Nslave)	NO	—
4.5.2.20	V(Nretry)	NO	—
4.5.2.21	V(Nrest_slot)	NO	—
4.5.2.22	V(Ndly_cnt)	NO	—
4.5.2.23	V(PDUType)	NO	—
4.5.2.24	V(SlotType)	YES	Option
4.5.2.25	V(Nms_1) , V(Nms_2)	NO	—
4.5.2.26	V(Nmr_1) , V(Nmr_2)	NO	—
4.5.2.27	V(Nmp_1) , V(Nmp_2)	NO	—
4.5.2.28	V(Nmf_1) , V(Nmf_2)	NO	—
4.5.2.29	V(Ten)	NO	—
4.5.2.30	V(Tdly)	NO	—
4.5.2.31	V(Tmax_dly)	NO	—
4.5.2.32	V(Tst)	NO	—
4.5.2.33	T(Tcycle)	YES	—
4.5.2.34	T(Tslot)	NO	—
4.5.2.35	T(Tmsg)	NO	—
4.5.2.36	T(Twrpt)	NO	—
4.5.2.37	Q(MSGc1s), Q(MSGc2s)	NO	—
4.5.2.38	Q(MSGc1r), Q(MSGc2r)	NO	—
6.2.3.2.1	Protocol machine for cyclic communication consist of fixed-width time slot	—	—
6.2.3.2.1.1	C1 master	NO	—
6.2.3.2.1.2	C2 master	NO	—
6.2.3.2.1.3	Slave	YES	—
6.2.3.3.2	Segmentation for short format DLPDU	—	—
6.2.3.3.2.1	Initiator for short format DLPDU	NO	—
6.2.3.3.2.2	Responder for short format DLPDU	YES	Option
7.3	DLM protocol machine	—	—
7.3.1	C1 master	NO	—
7.3.2	Slave and C2 master	YES	—

15.2.3 Application layer

15.2.3.1 AL service selection

15.2.3.1.1 Generic profile

Table 341 specifies the AL service selection within IEC 61158-5-24 for CP 19/1.

Table 341 – CP 19/1: AL service selection

Clause	Header	Presence	Constraints
1	Scope	YES	—
2	Normative reference	Partial	Used as needed
3	Terms, definitions, symbols, abbreviations and conventions	Partial	Used when applicable
4	Concepts	YES	—
5	Data type ASE	YES	—
6	Communication model specifications	—	—
6.1	Type specific concepts	YES	—
6.2	Overview	YES	—
6.3	FSM ASE	YES	See 15.2.3.1.2 to 15.2.3.1.4
6.4	FAL ASEs	—	—
6.4.1	Field device control ASE	—	—
6.4.1.1	Service overview	YES	—
6.4.1.2	Master class specifications	Partial	Depends on AP types
6.4.1.3	Slave class specifications	Partial	See 15.2.3.1.2 to 15.2.3.1.4
6.4.1.4	Monitor class specifications	Partial	
6.4.2	Message ASE	—	—
6.4.2.1	Service overview	YES	—
6.4.2.2	Requester class specifications	Partial	Depends on AP types
6.4.2.3	Responder class specifications	Partial	See 15.2.3.1.2 to 15.2.3.1.4
6.4.3	Event management ASE	YES	See 15.2.3.1.2 to 15.2.3.1.4
6.5	FAL ARs	—	—
6.5.1	AR model	YES	—
6.5.2	FDC AREP	—	—
6.5.2.1	FDC Master AR class	Partial	Depends on AP types
6.5.2.2	FDC Slave AR class	Partial	See 15.2.3.1.2 to 15.2.3.1.4
6.5.2.3	FDC Monitor AR class	Partial	
6.5.3	MSG AREP	Partial	Depends on AP types See 15.2.3.1.2 to 15.2.3.1.4

15.2.3.1.2 Details for C1 master

Table 342 specifies the ASE class selection within IEC 61158-5-24 for C1 master of CP 19/1.

Table 342 – Class selection for C1 master of CP 19/1

Clause	Class name	Presence	Constraints
6.3.2	FieldbusSystemManager	YES	Instantiatable number: 1 object
6.4.1.2	Master	Partial	Instantiatable number:30 objects See Table 343 and Table 344
6.4.1.3	Slave	NO	—
6.4.1.4	Monitor	NO	—
6.4.2.2	Requester	NO	—
6.4.2.3	Responder	NO	—
6.4.3.2	EventManager	YES	Instantiatable number: 1 object
6.5.2.1	FDC Master AR	Partial	Instantiatable number: 30 objects See Table 345 and Table 346
6.5.2.2	FDC Slave AR	NO	—
6.5.2.3	FDC Monitor AR	NO	—
6.5.3.1	Message AR	NO	—

Table 343 – Master class attribute selection for C1 master of CP 19/1

Attribute ref.	Attribute name	Usage	Constraints
1 – 4	—	O	—
5 – 7	—	M	—
8	TransMode	—	Cyclic mode only (pre defined)
9 – 13	—	M	—
14	DevProfileType	—	—
15 – 18	—	M	—

Table 344 – Master class service selection

Service ref.	Service name	Usage	Constraints
1 – 2	—	M	—
3	FDC-Enable	M	Parameter “TransmissionMode” is never used and Cyclic mode is pre-defined.
4 – 10	—	M	—

Table 345 – FDCMaster-AR class attribute selection for C1 master of CP 19/1

Attribute ref.	Attribute name	Usage	Constraints
1 – 4	—	O	—
5 – 7	—	M	—
8	TransMode	—	Cyclic mode only (pre defined)
9 – 11	—	M	—

Table 346 – FDCMaster-AR class service selection

Service ref.	Service name	Usage	Constraints
1 – 2	—	M	—
3	FDC-Enable	M	Parameter “TransmissionMode” is never used and Cyclic mode is pre-defined.
4 – 6	—	M	—
7	AR-SendCommand	—	—

15.2.3.1.3 Details for C2 master

Table 347 specifies the ASE class selection within IEC 61158-5-24 for C2 master of CP 19/1.

Table 347 – Class selection for C2 master of CP 19/1

Clause	Class name	Presence	Constraints
6.3.2	FieldbusSystemManager	YES	Instantiatable number: 1 object
6.4.1.2	Master	NO	—
6.4.1.3	Slave	NO	—
6.4.1.4	Monitor	Partial	Instantiatable number: 1 object See Table 348 and Table 349
6.4.2.2	Requester	YES	Instantiatable number: 1 object
6.4.2.3	Responder	NO	—
6.4.3.2	EventManager	YES	Instantiatable number: 1 object
6.5.2.1	FDC Master AR	NO	—
6.5.2.2	FDC Slave AR	NO	—
6.5.2.3	FDC Monitor AR	Partial	Instantiatable number: 30 objects See Table 350 and Table 351
6.5.3.1	Message AR	YES	Instantiatable number: 1 object

Table 348 – Monitor class attribute selection for C2 master of CP 19/1

Attribute ref.	Attribute name	Usage	Constraints
1 – 4	—	O	—
5 – 7	—	M	—
8	TransMode	—	Cyclic mode only (pre defined)

Table 349 – Monitor class service selection

Service ref.	Service name	Usage	Constraints
1 – 2	—	M	—
3	FDC-Enable	M	Parameter “TransmissionMode” is never used and Cyclic mode is pre-defined.
8, 11, 12	—	M	—

Table 350 – FDCMonitor-AR class attribute selection for C2 master of CP 19/1

Attribute ref.	Attribute name	Usage	Constraints
1 – 4	—	O	—
5 – 7	—	M	—
8	TransMode	—	Cyclic mode only (pre defined)
9 – 11	—	M	—

Table 351 – FDCMonitor-AR class service selection

Service ref.	Service name	Usage	Constraints
1 – 2	—	M	—
3	FDC-Enable	M	Parameter “TransmissionMode” is never used and Cyclic mode is pre-defined.
4, 8, 9	—	M	—

15.2.3.1.4 Details for slave AP

Table 352 specifies the ASE class selection within IEC 61158-5-24 for slave AP of CP 19/1.

Table 352 – Class selection for slave AP of CP 19/1

Clause	Class name	Presence	Constraints
6.3.2	FieldbusSystemManager	YES	Instantiatable number: 1 object
6.4.1.2	Master	NO	—
6.4.1.3	Slave	Partial	Instantiatable number: 1 object See Table 353 and Table 354
6.4.1.4	Monitor	NO	—
6.4.2.2	Requester	NO	—
6.4.2.3	Responder	YES	Optional Instantiatable number: 1 object
6.4.3.2	EventManager	YES	Instantiatable number: 1 object
6.5.2.1	FDC Master AR	NO	—
6.5.2.2	FDC Slave AR	Partial	Instantiatable number: 1 object See Table 355 and Table 356
6.5.2.3	FDC Monitor AR	NO	—
6.5.3.1	Message AR	YES	Optional Instantiatable number: 1 object

Table 353 – Slave class attribute selection for slave AP of CP 19/1

Attribute ref.	Attribute name	Usage	Constraints
1 – 4	—	O	—
5 – 7	—	M	—
8	TransMode	—	Cyclic mode only (pre defined)
9 – 13	—	M	—
14	DevProfileType	—	—
15 – 18	—	M	—

Table 354 – Slave class service selection

Service ref.	Service name	Usage	Constraints
1 – 2	—	M	—
3	FDC-Enable	M	Parameter “TransmissionMode” is never used and Cyclic mode is pre-defined.
4 – 10	—	M	—

Table 355 – FDCSlave-AR class attribute selection for slave AP of CP 19/1

Attribute ref.	Attribute name	Usage	Constraints
1 – 4	—	O	—
5 – 7	—	M	—
8	TransMode	—	Cyclic mode only (pre defined)
9 – 11	—	M	—

Table 356 – FDCSlave-AR class service selection

Service ref.	Service name	Usage	Constraints
1 – 2	—	M	—
3	FDC-Enable	M	Parameter “TransmissionMode” is never used and Cyclic mode is pre-defined.
4 – 6	—	M	—
7	AR-SendCommand	—	—

15.2.3.2 AL protocol selection

Table 357 specifies the AL protocol selection within IEC 61158-6-24 for this profile.

Table 357 – CP 19/1: AL protocol selection

Clause	Header	Presence	Constraints
1	Scope	YES	—
2	Normative reference	Partial	Used as needed
3	Terms, definitions, abbreviations, symbols and conventions	Partial	Used when applicable
4	Abstract syntax	—	—

Clause	Header	Presence	Constraints
4.1	Basic Data types	YES	—
4.2	FAL PDU types	—	—
4.2.1	Top of APDU types: _APDU	YES	—
4.2.2	PDU for field device control service	Partial	Used when applicable
4.2.3	PDU for message service	YES	—
4.3	Detailed definitions of _FDCservice-PDUs	—	—
4.3.1	Short PDU type	YES	—
4.3.2	Long PDU type	YES	—
4.3.3	Enhanced PDU type	NO	—
4.3.4	SubCommand PDU type	YES	—
4.4	Device profile	NO	—
5	Transfer syntax	YES	—
6	Structure of FAL protocol state machine	YES	—
7	AP-context state machine (APC SM)	YES	—
8	FAL service protocol machines (FSPM)	—	—
8.1	Overview	Partial	Used when applicable
8.2	Field Device Control Protocol Machine (FDC PM)	YES	—
8.3	Message Protocol Machine (MSGPM)	YES	—
9	Application relationship protocol machine (ARPM)	—	—
9.1	General	Partial	Used when applicable
9.2	ARPM for FDC ASE	YES	—
9.3	ARPM for MSG ASE (ARPM-MSG)	YES	—
10	DLL mapping protocol machine (DMPM)	YES	—
Annex A	Device profile and FDC command sets	NO	—
Annex B	Virtual memory space and device information	NO	—
Annex C	Basic message function	NO	—

15.3 Profile 19/2 (M-III)

15.3.1 Physical layer

The physical layer shall be according to ISO/IEC 8802-3.

As for connector specification, IEC 61158-2, Annex S is adopted additionally.

15.3.2 Data-link layer

15.3.2.1 DLL service selection

15.3.2.1.1 Generic profile

Table 358 specifies the DLL service selection within IEC 61158-3-24 for this profile.

Table 358 – CP 19/2: DLL service selection

Clause	Header	Presence	Constraints
1	Scope	YES	—
2	Normative references	Partial	Used as needed

Clause	Header	Presence	Constraints
3	Terms, definitions, symbols, abbreviations and conventions	Partial	Used when applicable
4	Data-link service and concepts	—	—
4.1	Overview	YES	—
4.2	DLS-user services	—	—
4.2.1	General	YES	—
4.2.2	Write data	YES	—
4.2.3	Read data	YES	—
4.2.4	Send data with acknowledge service (SDA)	YES	Option
4.2.5	Send data with no acknowledge service (SDN)	YES	Option
4.2.6	Event	YES	—
4.2.7	Get status	YES	—
4.3	Overview of interactions	YES	—
4.4	Detailed specification of services and interactions	—	—
4.4.1	Write data	YES	—
4.4.2	Read data	YES	—
4.4.3	Send data with acknowledge	YES	Option
4.4.4	Send data with no-acknowledge (SDN)	YES	Option
4.4.5	Cyclic event	YES	—
5	DL-management service	—	—
5.1	Overview	YES	—
5.2	Overview of interactions	YES	—
5.3	Detailed specification of services and interactions	—	—
5.3.1	Reset	YES	—
5.3.2	Set value	YES	—
5.3.2.1	Function	YES	—
5.3.2.2	Types of parameters	—	—
5.3.2.2.1	General	YES	—
5.3.2.2.2	Var_ID	Partial	See 15.3.2.1.2 to 15.3.2.1.4
5.3.2.2.4	Result	YES	—
5.3.3	Get value	—	—
5.3.3.1	Function	YES	—
5.3.3.2	Types of parameters	—	—
5.3.3.2.1	General	YES	—
5.3.3.2.2	Var_ID	Partial	See 15.3.2.1.2 to 15.3.2.1.4
5.3.3.2.3	Val	Partial	See 15.3.2.1.2 to 15.3.2.1.4
5.3.3.2.4	Result	YES	—
5.3.4	Evaluate delay	YES	—
5.3.5	Set communication mode	YES	—
5.3.6	Start communication	YES	—
5.3.7	DLM error event	YES	—

15.3.2.1.2 Detail for C1 master

Table 359 specifies DLL service selection within IEC 61158-3-24 for C1 master of CP 19/2.

Table 359 – DLL service selection for C1 master of CP 19/2

Clause	Header	Presence	Constraints
5.3.2.2.2	Var_ID	—	—
5.3.2.2.2.1	MA	YES	—
5.3.2.2.2.2	Nmax_slaves	YES	—
5.3.2.2.2.3	Cyc_sel	YES	—
5.3.2.2.2.4	Nmax_dly_cnt	YES	—
5.3.2.2.2.5	IO_sz	YES	—
5.3.2.2.2.6	Pkt_sz	YES	Option
5.3.2.2.2.7	Nmax_retry	YES	—
5.3.2.2.2.8	Tcycle	YES	—
5.3.2.2.2.9	Tslot	YES	—
5.3.2.2.2.10	Tunit	YES	—
5.3.2.2.2.11	Tidly	YES	—
5.3.2.2.2.12	Tc2_dly	YES	—
5.3.2.2.2.13	IO_Map	YES	—
5.3.2.2.3	Val	Partial	See Note
5.3.3.2.4	Result	Partial	See Note
NOTE Same as 5.3.2.2.2.1 to 5.3.2.2.2.13 in this table.			

15.3.2.1.3 Detail for C2 master

Table 360 specifies DLL service selection within IEC 61158-3-24 for C2 master of CP 19/2.

Table 360 – DLL service selection for C2 master of CP 19/2

Clause	Header	Presence	Constraints
5.3.2.2.2	Var_ID	—	—
5.3.2.2.2.1	MA	YES	—
5.3.2.2.2.2	Nmax_slaves	YES	—
5.3.2.2.2.3	Cyc_sel	YES	—
5.3.2.2.2.4	Nmax_dly_cnt	YES	—
5.3.2.2.2.5	IO_sz	YES	—
5.3.2.2.2.6	Pkt_sz	YES	Option
5.3.2.2.2.7	Nmax_retry	YES	—
5.3.2.2.2.8	Tcycle	YES	—
5.3.2.2.2.9	Tslot	YES	—
5.3.2.2.2.10	Tunit	YES	—
5.3.2.2.2.11	Tidly	YES	—
5.3.2.2.2.12	Tc2_dly	YES	—
5.3.2.2.2.13	IO_Map	YES	—
5.3.2.2.3	Val	Partial	See Note
5.3.3.2.4	Result	Partial	See Note
NOTE Same as 5.3.2.2.2.1 to 5.3.2.2.2.13 in this table.			

15.3.2.1.4 Detail for slave

Table 361 specifies DLL service selection within IEC 61158-4-24 for slave of CP 19/2.

Table 361 – DLL service selection for slave of CP 19/2

Clause	Header	Presence	Constraints
5.3.2.2.2	Var_ID	—	—
5.3.2.2.2.1	MA	YES	—
5.3.2.2.2.2	Nmax_slaves	YES	Option
5.3.2.2.2.3	Cyc_sel	YES	—
5.3.2.2.2.4	Nmax_dly_cnt	YES	—
5.3.2.2.2.5	IO_sz	YES	—
5.3.2.2.2.6	Pkt_sz	YES	Option
5.3.2.2.2.7	Nmax_retry	YES	—
5.3.2.2.2.8	Tcycle	YES	—
5.3.2.2.2.9	Tslot	NO	—
5.3.2.2.2.10	Tunit	YES	—
5.3.2.2.2.11	Tidly	YES	—
5.3.2.2.2.12	Tc2_dly	YES	—
5.3.2.2.2.13	IO_Map	YES	—
5.3.2.2.3	Val	Partial	See Note
5.3.3.2.4	Result	Partial	See Note
NOTE Same as 5.3.2.2.2.1 to 5.3.2.2.2.13 in this table.			

15.3.2.2 DLL protocol selection**15.3.2.2.1 Generic profile**

Table 362 specifies the DLL protocol selection within IEC 61158-4-24 for this profile.

Table 362 – CP 19/2: DLL protocol selection

Clause	Header	Presence	Constraints
1	Scope	YES	—
2	Normative references	Partial	Used as needed
3	Terms, definitions, symbols, abbreviations and conventions	Partial	Used when applicable
4	Overview of DL-protocol	—	—
4.1	Characteristic feature of DL-protocol	YES	—
4.2	DL layer component	YES	—
4.3	Timing sequence	—	—
4.3.1	Overview	YES	—
4.3.2	Cyclic transmission	—	—
4.3.2.1	Fixed-width time slot type	NO	—
4.3.2.2	Configurable time slot type	YES	—
4.3.2.3	Timing relationship between cyclic communication and data processing	YES	—
4.3.3	Acyclic transmission mode	YES	Option
4.4	Service assumed from PhL	YES	—
4.5	Local parameters, variables, counters, timers	—	—
4.5.1	Overview	YES	—
4.5.2	Variables, parameter, counter and timer to support DLE function	Partial	See 15.3.2.2.2 to 15.3.2.2.4
5	DLPDU structure	—	—
5.1	Overview	YES	—
5.2	Basic format DLPDU structure	YES	—
5.3	Short format DLPDU structure	NO	—
6	DLE element procedure	—	—
6.1	Overview	YES	—
6.2	Cyclic transmission control sublayer	—	—
6.2.1	General	YES	—
6.2.2	DLS-user interface	YES	—
6.2.3	Protocol machines in CTC	—	—
6.2.3.1	Overview	YES	—
6.2.3.2	Cyclic transmission protocol machine	—	—
6.2.3.2.1	Protocol machine for cyclic communication consist of fixed-width time slot	NO	—
6.2.3.2.2	Protocol machine for cyclic communication consist of configurable time slot	Partial	See 15.3.2.2.2 to 15.3.2.2.4
6.2.3.2.3	Functions used by cyclic transmission machine	Partial	—
6.2.3.3	Message segmentation protocol machine	—	—
6.2.3.3.1	General	YES	—

Clause	Header	Presence	Constraints
6.2.3.3.2	Segmentation for basic format DLPDU	Partial	Option See 15.3.2.2.2 to 15.3.2.2.4
6.2.3.3.3	Segmentation for short format DLPDU	NO	—
6.2.3.3.4	Functions used by message segmentation protocol machine	Partial	Option
6.2.3.4	Acyclic transmission protocol machine	YES	Option
6.2.4	CTC-DLM interface	YES	—
6.3	Send Receive Control	—	—
6.3.1	General	YES	—
6.3.1.1	Send frame	YES	—
6.3.1.2	Receive frame	YES	—
6.3.1.3	Repeater or loopback of received frame	YES	Option
6.3.2	SRC-CTC interface	YES	—
6.3.3	Detailed specification of SRC	—	—
6.3.3.1	Overview	YES	—
6.3.3.2	Serializer	—	—
6.3.3.2.1	Internal architecture	YES	—
6.3.3.2.2	Behaviour	—	—
6.3.3.2.2.1	Overview	YES	—
6.3.3.2.2.2	Serializer for basic format frame	YES	—
6.3.3.2.2.3	Serializer for short format frame	NO	—
6.3.3.3	Deserializer	—	—
6.3.3.3.1	Internal architecture	YES	—
6.3.3.3.2	Behaviour	—	—
6.3.3.3.2.1	Overview	YES	—
6.3.3.3.2.2	Deserializer for basic format frame	YES	—
6.3.3.3.2.3	Deserializer for short format frame	NO	—
6.3.3.4	Repeater	YES	Option
6.3.4	SRC-DLM interface	—	—
6.3.4.1	Overview	YES	—
6.3.4.2	Detailed definition of the services primitive and parameters	YES	—
6.3.4.2.1	SRC_Reset	YES	—
6.3.4.2.2	SRC_Send_Frame	YES	—
6.3.4.2.3	SRC_Recv_Frame	YES	—
6.3.4.2.4	SRC_Enable_Loopback	YES	See 15.3.2.2.2 to 15.3.2.2.4
6.3.4.2.5	SRC_Err_Event	YES	—
7	DL management layer (DLM)	—	—
7.1	Overview	YES	—
7.2	Primitive definitions	YES	—
7.3	DLM protocol machine	Partial	See 15.3.2.2.2 to 15.3.2.2.4
7.4	Functions	Partial	—

15.3.2.2.2 Detail for C1 master

Table 363 specifies DLL protocol selection within IEC 61158-4-24 for C1 master of CP 19/2.

Table 363 – DLL protocol selection for C1 master of CP 19/2

Clause	Header	Presence	Constraints
4.5.2	Variables, parameters, counters and timers to support DLE function	—	—
4.5.2.1	V(MA), P(MA)	YES	—
4.5.2.2	V(Tcycle), P(Tcycle)	YES	—
4.5.2.3	V(Nmax_slaves), P(Nmax_slaves)	YES	—
4.5.2.4	V(Cyc_sel), P(Cyc_sel)	YES	—
4.5.2.5	V(Nmax_dly_cnt), P(Nmax_dly_cnt)	YES	—
4.5.2.6	V(IO_sz), P(IO_sz)	YES	—
4.5.2.7	V(Pkt_sz), P(Pkt_sz)	Yes	Option
4.5.2.8	V(Nmax_retry), P(Nmax_retry)	YES	—
4.5.2.9	V(Tslot), P(Tslot)	YES	—
4.5.2.10	V(Tunit), P(Tunit)	YES	—
4.5.2.11	V(Tidly), P(Tidly)	YES	—
4.5.2.12	V(Tc2_dly), P(Tc2_dly)	YES	—
4.5.2.13	V(Tmsg), P(Tmsg)	YES	—
4.5.2.14	T(Twrpt)	YES	—
4.5.2.15	V(IO_MAP), P(IO_MAP)	YES	—
4.5.2.16	V(Sts_STI), P(Sts_STI)	YES	—
4.5.2.17	V(Sts_Err), P(Sts_Err)	YES	—
4.5.2.18	V(Fc2msg)	YES	—
4.5.2.19	V(Nslave)	YES	—
4.5.2.20	V(Nretry)	YES	—
4.5.2.21	V(Nrest_slot)	YES	—
4.5.2.22	V(Ndly_cnt)	YES	—
4.5.2.23	V(PDUType)	YES	—
4.5.2.24	V(SlotType)	YES	Option
4.5.2.25	V(Nms_1), V(Nms_2)	YES	Option
4.5.2.26	V(Nmr_1), V(Nmr_2)	YES	Option
4.5.2.27	V(Nmp_1), V(Nmp_2)	YES	Option
4.5.2.28	V(Nmf_1), V(Nmf_2)	YES	Option
4.5.2.29	V(Ten)	YES	—
4.5.2.30	V(Tdly)	YES	—
4.5.2.31	V(Tmax_dly)	YES	—
4.5.2.32	V(Tst)	YES	—
4.5.2.33	T(Tcycle)	YES	—
4.5.2.34	T(Tslot)	YES	—
4.5.2.35	T(Tmsg)	YES	—
4.5.2.36	T(Twrpt)	NO	—
4.5.2.37	Q(MSGc1s), Q(MSGc2s)	YES	—
4.5.2.38	Q(MSGc1r), Q(MSGc2r)	YES	—
6.2.3.2.2	Protocol machine for cyclic communication consist of configurable time slot	—	—
6.2.3.2.2.1	C1 master	YES	—

Clause	Header	Presence	Constraints
6.2.3.2.2.2	C2 master	NO	—
6.2.3.2.2.3	Slave	NO	—
6.2.3.3.1	Segmentation for basic format DLPDU	YES	Option
6.2.3.3.1.1	Initiator for basic format DLPDU	YES	Option
6.2.3.3.1.2	Responder for basic format DLPDU	YES	Option
6.3.4.2.4	SRC_Enable_Loopback	NO	—
7.3	DLM protocol machine	—	—
7.3.1	C1 master r	YES	—
7.3.2	Slave and C2 master	NO	—

15.3.2.2.3 Detail for C2 master

Table 364 specifies DLL protocol selection within IEC 61158-4-24 for C2 master of CP 19/2.

Table 364 – DLL protocol selection for C2 master of CP 19/2

Clause	Header	Presence	Constraints
4.5.2	Variables, parameters, counters and timers to support DLE function	—	—
4.5.2.1	V(MA), P(MA)	YES	—
4.5.2.2	V(Tcycle), P(Tcycle)	YES	—
4.5.2.3	V(Nmax_slaves), P(Nmax_slaves)	YES	—
4.5.2.4	V(Cyc_sel), P(Cyc_sel)	YES	—
4.5.2.5	V(Nmax_dly_cnt), P(Nmax_dly_cnt)	YES	—
4.5.2.6	V(IO_sz), P(IO_sz)	YES	—
4.5.2.7	V(Pkt_sz), P(Pkt_sz)	YES	Option
4.5.2.8	V(Nmax_retry), P(Nmax_retry)	NO	—
4.5.2.9	V(Tslot), P(Tslot)	YES	—
4.5.2.10	V(Tunit), P(Tunit)	YES	—
4.5.2.11	V(Tidly), P(Tidly)	YES	—
4.5.2.12	V(Tc2_dly), P(Tc2_dly)	YES	—
4.5.2.13	V(Tmsg), P(Tmsg)	YES	—
4.5.2.14	T(Twrpt)	NO	—
4.5.2.15	V(IO_MAP), P(IO_MAP)	YES	—
4.5.2.16	V(Sts_STI), P(Sts_STI)	YES	—
4.5.2.17	V(Sts_Err), P(Sts_Err)	YES	—
4.5.2.18	V(Fc2msg)	YES	—
4.5.2.19	V(Nslave)	YES	—
4.5.2.20	V(Nretry)	NO	—
4.5.2.21	V(Nrest_slot)	NO	—
4.5.2.22	V(Ndly_cnt)	NO	—
4.5.2.23	V(PDUType)	NO	—
4.5.2.24	V(SlotType)	YES	Option
4.5.2.25	V(Nms_1), V(Nms_2)	YES	Option
4.5.2.26	V(Nmr_1), V(Nmr_2)	YES	Option

Clause	Header	Presence	Constraints
4.5.2.27	V(Nmp_1) , V(Nmp_2)	YES	Option
4.5.2.28	V(Nmf_1) , V(Nmf_2)	YES	Option
4.5.2.29	V(Ten)	NO	—
4.5.2.30	V(Tdly)	YES	—
4.5.2.31	V(Tmax_dly)	NO	—
4.5.2.32	V(Tst)	NO	—
4.5.2.33	T(Tcycle)	YES	—
4.5.2.34	T(Tslot)	YES	—
4.5.2.35	T(Tmsg)	YES	—
4.5.2.36	T(Twrpt)	YES	—
4.5.2.37	Q(MSGc1s), Q(MSGc2s)	YES	—
4.5.2.38	Q(MSGc1r), Q(MSGc2r)	YES	—
6.2.3.2.2	Protocol machine for cyclic communication consist of configurable time slot	—	—
6.2.3.2.2.1	C1 master	NO	—
6.2.3.2.2.2	C2 master	YES	—
6.2.3.2.2.3	Slave	NO	—
6.2.3.3.1	Segmentation for basic format DLPDU	YES	Option
6.3.4.2.4	SRC_Enable_Loopback	YES	—
7.3	DLM protocol machine	—	—
7.3.1	C1 master	NO	—
7.3.2	Slave and C2 master	YES	—

15.3.2.2.4 Detail for slave

Table 365 specifies DLL protocol selection within IEC 61158-4-24 for slave of CP 19/2.

Table 365 – DLL protocol selection for slave of CP 19/2

Clause	Header	Presence	Constraints
4.5.2	Variables, parameters, counters and timers to support DLE function	—	—
4.5.2.1	V(MA), P(MA)	YES	—
4.5.2.2	V(Tcycle), P(Tcycle)	YES	—
4.5.2.3	V(Nmax_slaves), P(Nmax_slaves)	NO	—
4.5.2.4	V(Cyc_sel), P(Cyc_sel)	YES	—
4.5.2.5	V(Nmax_dly_cnt), P(Nmax_dly_cnt)	YES	—
4.5.2.6	V(IO_sz), P(IO_sz)	YES	—
4.5.2.7	V(Pkt_sz), P(Pkt_sz)	YES	Option
4.5.2.8	V(Nmax_retry), P(Nmax_retry)	NO	—
4.5.2.9	V(Tslot), P(Tslot)	NO	—
4.5.2.10	V(Tunit), P(Tunit)	YES	—
4.5.2.11	V(Tidly), P(Tidly)	YES	—
4.5.2.12	V(Tc2_dly), P(Tc2_dly)	NO	—
4.5.2.13	V(Tmsg), P(Tmsg)	NO	—
4.5.2.14	T(Twrpt)	NO	—
4.5.2.15	V(IO_MAP), P(IO_MAP)	YES	—
4.5.2.16	V(Sts_STI), P(Sts_STI)	YES	—
4.5.2.17	V(Sts_Err), P(Sts_Err)	YES	—
4.5.2.18	V(Fc2msg)	NO	—
4.5.2.19	V(Nslave)	NO	—
4.5.2.20	V(Nretry)	NO	—
4.5.2.21	V(Nrest_slot)	NO	—
4.5.2.22	V(Ndly_cnt)	NO	—
4.5.2.23	V(PDUType)	NO	—
4.5.2.24	V(SlotType)	YES	Option
4.5.2.25	V(Nms_1), V(Nms_2)	YES	Option
4.5.2.26	V(Nmr_1), V(Nmr_2)	YES	Option
4.5.2.27	V(Nmp_1), V(Nmp_2)	YES	Option
4.5.2.28	V(Nmf_1), V(Nmf_2)	YES	Option
4.5.2.29	V(Ten)	NO	—
4.5.2.30	V(Tdly)	YES	—
4.5.2.31	V(Tmax_dly)	YES	—
4.5.2.32	V(Tst)	NO	—
4.5.2.33	T(Tcycle)	YES	—
4.5.2.34	T(Tslot)	NO	—
4.5.2.35	T(Tmsg)	NO	—
4.5.2.36	T(Twrpt)	YES	—
4.5.2.37	Q(MSGc1s), Q(MSGc2s)	YES	—
4.5.2.38	Q(MSGc1r), Q(MSGc2r)	YES	—
6.2.3.2.2	Protocol machine for cyclic communication consist of configurable time slot	—	—
6.2.3.2.2.1	C1 master	NO	—

Clause	Header	Presence	Constraints
6.2.3.2.2.2	C2 master	NO	—
6.2.3.2.2.3	Slave	YES	—
6.2.3.3.1	Segmentation for basic format DLPDU	—	Option
6.2.3.3.1.1	Initiator for short format DLPDU	NO	—
6.2.3.3.1.2	Responder for short format DLPDU	YES	Option
6.3.4.2.4	SRC_Enable_Loopback	YES	—
7.3	DLM protocol machine	—	—
7.3.1	C1 master	NO	—
7.3.2	Slave and C2 master	YES	—

15.3.3 Application layer

15.3.3.1 AL service selection

15.3.3.1.1 Generic profile

Table 366 specifies the AL service selection within IEC 61158-5-24 for CP 19/2.

Table 366 – CP 19/2: AL service selection

Clause	Header	Presence	Constraints
1	Scope	YES	—
2	Normative reference	Partial	Used as needed
3	Terms, definitions, symbols, abbreviations and conventions	Partial	Used when applicable
4	Concepts	YES	—
5	Data type ASE	YES	—
6	Communication model specifications	—	—
6.1	Type specific concepts	YES	—
6.2	Overview	YES	—
6.3	FSM ASE	YES	See 15.2.3.1.2 to 15.2.3.1.4
6.4	FAL ASEs	—	—
6.4.1	Field device control ASE	—	—
6.4.1.1	Service overview	YES	—
6.4.1.2	Master class specifications	YES	Depends on AP types
6.4.1.3	Slave class specifications	YES	See 15.2.3.1.2 to 15.2.3.1.4
6.4.1.4	Monitor class specifications	YES	
6.4.2	Message ASE	—	—
6.4.2.1	Service overview	YES	—
6.4.2.2	Requester class specifications	YES	Depends on AP types
6.4.2.3	Responder class specifications	YES	See 15.2.3.1.2 to 15.2.3.1.4
6.4.3	Event management ASE	Partial	See 15.2.3.1.2 to 15.2.3.1.4
6.5	FAL ARs	—	—
6.5.1	AR model	YES	—
6.5.2	FDC AREP	—	—
6.5.2.1	FDC Master AR class	YES	Depends on AP types
6.5.2.2	FDC Slave AR class	YES	See 15.2.3.1.2 to 15.2.3.1.4

Clause	Header	Presence	Constraints
6.5.2.3	FDC Monitor AR class	YES	
6.5.3	MSG AREP	YES	Depends on AP types See 15.2.3.1.2 to 15.2.3.1.4

15.3.3.1.2 Details for C1 master

Table 367 specifies the ASE class selection within IEC 61158-5-24 for C1 master of CP 19/2.

Table 367 – Class selection for C1 master of CP 19/2

Clause	Class name	Presence	Constraints
6.3.2	FieldbusSystemManager	YES	Instantiatable number: 1 object
6.4.1.2	Master	YES	Instantiatable number:62 objects
6.4.1.3	Slave	NO	—
6.4.1.4	Monitor	NO	—
6.4.2.2	Requester	YES	Optional Instantiatable number: 1 object
6.4.2.3	Responder	YES	Optional Instantiatable number: 1 object
6.4.3.2	EventManager	Partial	Instantiatable number: 1 object See Table 368 and Table 369
6.5.2.1	FDC Master AR	YES	Instantiatable number: 62 objects
6.5.2.2	FDC Slave AR	NO	—
6.5.2.3	FDC Monitor AR	NO	—
6.5.3.1	Message AR	YES	Optional Instantiatable number: 2 objects

Table 368 – EventManager class attribute selection for C1 master of CP 19/2

Attribute ref.	Attribute name	Usage	Constraints
1 – 4	—	O	—
5	SAPID	M	—
6	NetworkClock	—	—

Table 369 – EventManager class service selection

Service ref.	Service name	Usage	Constraints
1 – 2	—	M	—
3	EVM-SyncEvent	M	Parameter “NetClock” is option
4	EVM-ReadNetClock	O	—

15.3.3.1.3 Details for C2 master

Table 370 specifies the ASE class selection within IEC 61158-5-24 for C2 master of CP 19/2.

Table 370 – Class selection for C2 master of CP 19/2

Clause	Class name	Presence	Constraints
6.3.2	FieldbusSystemManager	YES	Instantiatable number: 1 object
6.4.1.2	Master	NO	—
6.4.1.3	Slave	NO	—
6.4.1.4	Monitor	YES	Instantiatable number: 1 object
6.4.2.2	Requester	YES	Instantiatable number: 1 object
6.4.2.3	Responder	YES	Optional Instantiatable number: 1 object
6.4.3.2	EventManager	Partial	Instantiatable number: 1 object See Table 371 and Table 372
6.5.2.1	FDC Master AR	NO	—
6.5.2.2	FDC Slave AR	NO	—
6.5.2.3	FDC Monitor AR	YES	Instantiatable number: 62 objects
6.5.3.1	Message AR	YES	Instantiatable number: 2 objects

Table 371 – EventManager class attribute selection for C2 master of CP 19/2

Attribute ref.	Attribute name	Usage	Constraints
1 – 4	—	O	—
5	SAPID	M	—
6	NetworkClock	—	—

Table 372 – EventManager class service selection

Service ref.	Service name	Usage	Constraints
1 – 2	—	M	—
3	EVM-SyncEvent	M	Parameter “NetClock” is option
4	EVM-ReadNetClock	O	—

15.3.3.1.4 Details for slave AP

Table 373 specifies the ASE class selection within IEC 61158-5-24 for slave AP of CP 19/2.

Table 373 – Class selection for slave AP of CP 19/2

Clause	Class name	Presence	Constraints
6.3.2	FieldbusSystemManager	YES	Instantiatable number: 1 object
6.4.1.2	Master	NO	—
6.4.1.3	Slave	YES	Instantiatable number: 1 object
6.4.1.4	Monitor	YES	Optional Instantiatable number: 1 object
6.4.2.2	Requester	NO	—
6.4.2.3	Responder	YES	Optional Instantiatable number: 2 objects
6.4.3.2	EventManager	Partial	Instantiatable number: 1 object See Table 374 and Table 375
6.5.2.1	FDC Master AR	NO	—
6.5.2.2	FDC Slave AR	YES	Instantiatable number: 1 object
6.5.2.3	FDC Monitor AR	YES	Optional Instantiatable number: 61 objects
6.5.3.1	Message AR	YES	Optional Instantiatable number: 2 objects

Table 374 – EventManager class attribute selection for slave AP of CP 19/2

Attribute ref.	Attribute name	Usage	Constraints
1 – 4	—	O	—
5	SAPID	M	—
6	NetworkClock	—	—

Table 375 – EventManager class service selection

Service ref.	Service name	Usage	Constraints
1 – 2	—	M	—
3	EVM-SyncEvent	M	Parameter “NetClock” is option
4	EVM-ReadNetClock	O	—

15.3.3.2 AL protocol selection

Table 376 specifies the AL protocol selection within IEC 61158-6-24 for this profile.

Table 376 – CP 19/2: AL protocol selection

Clause	Header	Presence	Constraints
1	Scope	YES	—
2	Normative reference	Partial	Used as needed
3	Terms, definitions, abbreviations, symbols and conventions	YES	—
4	Abstract syntax	—	—
4.1	Basic Data types	YES	—
4.2	FAL PDU types	—	—
4.2.1	Top of APDU types: _APDU	YES	
4.2.2	PDU for field device control service	Partial	Used when applicable
4.2.3	PDU for message service	YES	—
4.3	Detailed definitions of _FDCService-PDUs	—	—
4.3.1	Short PDU type	NO	—
4.3.2	Long PDU type	NO	—
4.3.3	Enhanced PDU type	YES	—
4.3.4	SubCommand PDU type	NO	—
4.4	Device profile	YES	—
5	Transfer syntax	YES	—
6	Structure of FAL protocol state machine	YES	—
7	AP-context state machine (APC SM)	YES	—
8	FAL service protocol machines (FSPM)	—	—
8.1	Overview	Partial	Used when applicable
8.2	Field Device Control Protocol Machine (FDC PM)	YES	—
8.3	Message Protocol Machine (MSGPM)	YES	—
9	Application relationship protocol machine (ARPM)	—	—
9.1	General	Partial	Used when applicable
9.2	ARPM for FDC ASE	YES	—
9.3	ARPM for MSG ASE (ARPM-MSG)	YES	—
10	DLL mapping protocol machine (DMPM)	YES	—
Annex A	Device profile and FDC command sets	YES	—
Annex B	Virtual memory space and device information	YES	—
Annex C	Basic message function	YES	—

Annex A (informative)

Communication concepts

A.1 CPF 1 (FOUNDATION Fieldbus) communication concepts

A.1.1 Overview

The FOUNDATION Fieldbus specifications describe both:

H1: A physical layer, data-link layer, application layer (communication objects and services), and associated management functions, designed to operate in a hazardous environment under Intrinsic Safety rules, and in many cases to operate over existing cables of the type used for analog 4 mA to 20 mA signaling, with both power and signaling conveyed on those cables.

HSE: An application layer (communication objects and services) and associated management functions, designed to operate over a standard TCP/UDP/IP stack, frequently over twisted-pair or fiber-optic switched Ethernet.

A.1.2 Physical layer characteristics

A.1.2.1 H1 physical layer

The H1 physical layer provides low-speed (31,25 kbit/s) communication over shared broadcast physical media composed of either or both

- a) low-grade shielded wiring of the kind frequently used for 4 mA to 20 mA analog signaling, usually configured as a multi-drop bus;
- b) single or paired fiber optic cables connected through one or more star couplers.

In case a), the devices may themselves be powered from the physical media.

A.1.2.2 HSE physical layer

The HSE Physical Layer is usually that of standard twisted-pair and/or fiber-optic switched Ethernet.

A.1.3 Data-link layer characteristics

A.1.3.1 H1 data-link layer

The H1 data-link layer (DLL) provides coordinated access to the shared physical medium. The H1 DLL provides:

- a) periodic scheduled access to various devices to multicast (produce) information on a predetermined schedule, and
- b) non-scheduled round-robin access to all active devices to send information whose transmission is not scheduled,
- c) detection of the arrival and departure of participating devices, and management of their data-link layer attribute configuration and interaction with the rest of the system.

Except for abnormal cases arising from compound errors or unusual media noise, the periodic schedule a) always takes precedence over b) and c).

The H1 DLL provides point-to-point connected operation, point-to-multipoint connected operation, and multipoint-to-multipoint connectionless operation, using both current-message

buffers and FIFO message queues. Bridging of all three types of communication is also specified, with appropriate handling of current-message buffers within the bridges.

The H1 DLL provides all connected devices with a highly synchronized sense of time progression, providing the foundation for distributed sequence-of-events detection and recording applications.

A.1.3.2 HSE data-link, network and transport layers

The HSE data-link layer is typically that of switched Ethernet carrying ISO/IEC 8802-3, carrying connectionless ISO/IEC 8802-2, carrying a standard IP network layer, carrying standard TCP and UDP transport layer protocols. The functionality of TCP and UDP over IP over switched Ethernet is roughly comparable to that of the H1 data-link layer.

A.1.4 Application layer characteristics

The H1 and HSE application layer service specifications define essentially the same service interface to the user layer. Minor differences exist in the application layer protocol specifications due to the difference between H1 and HSE data rates and packet sizes. That is, the HSE application layer protocol provides for longer messages and longer identifiers, but the services they convey are the same.

A.1.5 Management characteristics

The HSE application layer defines a set of services and protocols supporting the following aspects of HSE management:

- “Plug and play” of HSE devices.
In this context, “plug and play” means the discovery of new HSE devices on the network and the assignment and maintenance of basic configuration information to them.
- Management of redundant network interfaces.
This capability protects against single and multiple faults in the network. Each device monitors the network and selects the “best” route to each destination for each message it sends.
- Locating HSE devices and device objects.
This is similar to a distributed directory service, in which a device with a queried object responds with information that allows the requester to access the object. The object may be the device itself, an application in the device, or an object within an application in the device.
- Synchronizing application execution with other devices on the network.
This capability supplements standard time distribution protocols. This capability divides time into intervals called macrocycles. Applications are started at specific offsets from the start of each macrocycle. Mechanisms within the protocol limit the impact on long macrocycles of loss of contact with the time source.

A.2 CPF 2 (CIP) communication concepts

A.2.1 Overview

Communication Profile Family 2 defines several communication profiles (ControlNet, EtherNet/IP and DeviceNet), which all share for their upper layers the same communication system commonly known as the Common Industrial Protocol (CIP). These profiles allow seamless integration of all components in an automation system, from the simplest device to the internet: application requirements will determine which profile(s) will be used in the system, based on their different data-link and physical layers characteristics.

A.2.2 CIP common characteristics

The CIP specification comprises communication objects and services, and the associated management functions.

Devices exchange data packets using the Producer/Consumer communication model. Instead of specifying source and destination addresses, data packets are individually labelled with a shorthand name CID (Connection ID). A producer broadcasts a data packet on the wire, while all interested consumers can pick this packet off the wire at the same time by filtering on the CID, and use this same data. This model allows virtually all classical modes of communication : master/slave, multi-master, or peer-to-peer.

For monitoring purpose, CIP requires that a formal connection is established between applications entities before information can be transferred. A connection defines a path or virtual circuit between end points for data to be transferred. Specific mechanisms allow some unconnected transfers, e.g. for connection establishment.

Multiple options are available for connections, and can be combined to fit a wide range of various application needs. Connections can be peer-to-peer or multicast. Data trigger may be “cyclic”, “change-of-state”, “application triggered”, “poll” or “bit-strobe”. Other options allow to select duplicate detection, acknowledge, verification, fragmentation (for large messages). Available options depend on the selected communication profile.

CIP protocol layers are based on object-oriented design principles. Both communication and application entities are referred to as objects. CIP explicit messaging connections are used to request services to be performed on corresponding object instances (or their attributes). This scheme provides an explicit reference to all configuration, status, and runtime variables data in a node. At the same time, (implicit) I/O connections allows direct and efficient exchange with the I/O database, without intermediate processing.

CIP specifies harmonized behaviors for specific communication indicators, in order to ease overall network troubleshooting.

A.2.3 ControlNet

A.2.3.1 Physical layer characteristics

ControlNet provides three media variants :

- RG6 (cable TV) coaxial cable is used with BNC or TNC connectors in a passive bus topology (coax Tap devices connect products to the main trunk via drop lines)
- Fiber optic is supported as a point to point link or ring topology
- Network Access Port (local RS-422 type connection), allows temporary and direct access to the network for system commissioning, troubleshooting, or programming

NOTE It is possible to design coax and fiber systems to meet the requirements of intrinsic safety environments.

Various bus topologies are allowed, such as linear trunk, tree, star, and combinations of any of these. A ControlNet network supports up to 99 nodes. It can passively extend to 1 000 m with two nodes, 250 m with 48 nodes, and up to 25 km if repeaters are used.

Media redundancy is supported : all components of a redundant system are connected and listen continuously to both cables, and decide independently which cable has the best signal.

Data is transmitted at the rate of 5 Mbit/s. It is Manchester encoded, which provides accurate clock recovery and synchronization, and increased transmission reliability. Transmitted packets include a 16-bit CRC for additional error detection.

A.2.3.2 Data-link layer characteristics

ControlNet uses for Media Access a specific method called CTDMA (Concurrent Time Domain Multiple Access), designed to ensure that performance of time critical data transfer (e.g. I/O, analog, control, peer to peer interlocking data), is not impacted by non time critical data transfer (e.g. messaging, programming, connection establishment).

A time slice algorithm is used: time is divided in repeating NUTs (Network Update Times), which duration can be configured between 2 ms and 100 ms. Transmission time is allocated in each NUT based on the time critical nature of the data to be transmitted :

- Nodes reserve (by configuration) transmission time for real time data, based on application requirements (exchange rate can be different for each packet of application data). This scheduled service is deterministic and repeatable.
- Remaining transmission time is used for non time critical data. This unscheduled service is not reserved by individual nodes, but is used as needed. This way, data sent in the unscheduled service does not impact delivery of data sent in the scheduled service, and is still predictable (maximum delivery time).

Media access is granted to individual nodes using an implicit token rotation algorithm within each NUT. This access method also includes duplicate node address detection.

Individual variable size data packets from the application are assembled within a node in MAC frames of up to 510 bytes of useful data, for increased transmission efficiency.

A.2.3.3 Management characteristics

ControlNet provides dynamic rescheduling of the network. Each node holds a copy of the link parameters and local scheduling information. Specific Keeper nodes hold the link and scheduling parameters for the global network: the primary Keeper ensures overall configuration consistency during startup and on-line re-configuration of the network, while secondary Keepers automatically backup the primary one. As a result, individual scheduled connections can be changed without affecting current data exchanges on the link, and even nodes can be added or removed without affecting other nodes.

A.2.4 EtherNet/IP

The EtherNet/IP profile, as detailed in the profile section above, uses the CIP application layer in conjunction with the standard, unmodified TCP/UDP/IP/Ethernet protocol suite.

EtherNet/IP uses IEEE 802.3 technology at the physical and data link layers.

Compliance with IEEE Ethernet standards provides users with a choice of network interface speeds (e.g. 10, 100 Mbit/s and 1 Gbit/s), and a flexible network architecture compatible with available Ethernet media options including copper, fiber, fiber ring and wireless.

EtherNet/IP uses an active infrastructure, and is typically configured using a series of network segments constructed of point-to-point connections in a star configuration. The core of this topology is an interconnection of Ethernet layer 2 and layer 3 switches that can accommodate an unlimited number of point-to-point nodes. At a higher level, EtherNet/IP networks can be either isolated (not connected directly to the enterprise network) or non-isolated, meaning the network is either connected to or integrated with the enterprise network.

At the upper layers, EtherNet/IP utilizes the Internet standards known as the Transmission Control Protocol / User Datagram Protocol / Internet Protocol (TCP/UDP/IP) suite to send messages between one or more devices.

- Since TCP is ideal for the reliable transmission of large quantities of data, EtherNet/IP uses TCP/IP to encapsulate CIP explicit messages, which are generally used to transmit configuration, diagnostic and event data.
- Since UDP messages are smaller, they can be processed more quickly; they can also be multicast to a group of destination addresses. Therefore, EtherNet/IP uses UDP/IP to transport (implicit) I/O messages that typically contain time-critical control data. The CIP connection mechanism provides timeout mechanisms that can detect data delivery problems.

EtherNet/IP is also compatible with standard Internet protocols and standard industrial protocols for data access and exchange.

A.2.5 DeviceNet

The DeviceNet profile is intended to connect simple industrial devices (such as sensors and actuators) with controlling devices (such a programmable controllers): it supports the transmission of I/O data, diagnostics, messaging and programming/configuration.

The DeviceNet profile, as detailed in the profile section above, uses the CIP application layer in conjunction with the ISO 11898 (CAN) data-link and physical layers, with additional elements specified in IEC 62026-3 (mapping of CIP onto CAN, transceiver and media specifications).

DeviceNet uses two twisted shielded conductor pairs within one cable – one of these pairs provides a differential communication medium, and the other pair provides power to the devices. The maximum current supported is 8 A at 24 V d.c. Data is transmitted at bit rates of 125 kbit/s, 250 kbit/s or 500 kbit/s with maximum cable lengths of 500 m, 250 m, and 100 m respectively. 64 nodes may be connected using a linear topology with a trunk line and drop lines. Up to 8 bytes of data may be transmitted without fragmentation.

A.3 CPF 3 (PROFIBUS & PROFINET) communication concepts

A.3.1 Basic characteristics

A.3.1.1 General

PROFIBUS defines the technical characteristics of a serial field bus system with which distributed digital programmable controllers can be networked, from field level to cell level.

A.3.1.2 PROFIBUS DP

PROFIBUS DP is a multi-master system and thus allowing the joint operation of several automation, engineering or visualization systems with their distributed peripherals on one fieldbus. PROFIBUS DP is the protocol and service specification that is to combine with different physical layers and medium attachment units (MAU). PROFIBUS DP distinguishes between the following types of device:

Master devices determine the data communication on the bus. A master can send messages without an external request when it holds the bus access rights (the token). Masters are also called active stations.

The DP-master (Class 1) is a controlling device, which is associated with one or more DP-Slaves (field devices). The DP-master (Class 1) performs basic functionalities and optionally DPV1 features.

The DP-master (Class 2) is a controlling device, which manages configuration data (parameter sets) and Diagnosis data of a DP-master (Class 1). Additionally the DP-master (Class 2) can perform all communication capabilities of a DP-master (Class 1) to a DP-slave.

Slave devices are field devices such as I/O devices, valves, drives and measuring transducers. The slave devices can be assigned to one DP-master (Class1) as a provider for cyclic I/O data exchange; in addition acyclic functions and alarms could be provided.

DP-V0 PROFIBUS devices (master and slaves) performs the following basic functionalities:

- Cyclic exchange of I/O data
- Diagnosis
- Parameterization of DP-slaves
- Configuration of DP-slaves
- Treatment of configuration and diagnosis requests of a DP-master (Class 2)

DP-V1 PROFIBUS devices comply with the following features:

- Device related diagnosis is replaced by status messages and alarms.
- The first three octets of the user parameterization data get a specific meaning (DPV1_Status_1 to DPV1_Status_3), to enable new communication functionalities e.g. alarms (see IEC 61158-6-3, where the attribute DPV1 is set to TRUE).

Options: DP-V1 features are mandatory for optional new communication functionalities (see 7.2.3.2.5). For example:

- Acyclic process data
- Alarms (Devices which supports alarms has also to support the acyclic services)
- Isochronous Mode
- DXB mechanism for cyclic data exchange between DP-slaves using the Publisher/Subscriber communication
- Up- and/or download of LR Data (domains)
- Invocation of predefined functions within DP-slaves
- Clock synchronization
- Redundancy

A.3.2 Physical layer profiles

The application area of a field bus system is largely determined by the choice of transmission technology available. As well as the general demands made on bus systems, such as high transmission reliability, large distances and high transmission speed, in process automation additional requirements, such as operation in hazardous areas and the transmission of data and energy on a common cable, exist. Since it is not yet possible to satisfy all requirements with a single transmission technology, there are currently three transmission methods (physical layer profiles) available for PROFIBUS:

- Copper (RS 485) for universal applications with optional IS (RS 485-IS).
- Fiber Optic for improved interference immunity and large network distances. The following MAU are specified:
 - Glass Multi mode fiber and Single mode fiber
 - Plastic fiber
 - PCF Fiber

Copper & Power based on synchronous transmission for use in intrinsic / non intrinsic safety area and with the option of “Low Power”. Couplers or links are available for the transition between the various transmission technologies. While couplers transparently implement the protocol taking account of physical circumstances, links are intrinsically intelligent and thus offer extended options for the configuration of PROFIBUS networks.

A.3.3 Communication feature list (GSD)

PROFIBUS devices have different behavior and performance characteristics. Features differ in regard to available functionality (i.e., number of I/O signals and diagnostic messages) or possible bus parameters such as baud rate and time monitoring. These parameters vary individually for each device type and vendor and are usually documented in the technical manual. In order to achieve a simple Plug and Play configuration for PROFIBUS, electronic device data sheets were defined to list the communication features of the devices (GSD files). Based on the GSD files, these allow manufacturer independent configuration of PROFIBUS networks with devices from different manufacturers. The GSD file is divided into three sections:

- General specifications

This section contains information on vendor and device names, hardware and software release states, baud rates supported, possible time intervals for monitoring times and the signal assignment on the bus connector.

- Master-related specifications

This section contains all master-related parameters, such as: the maximum number of slaves that can be connected, or upload and download options. This section does not exist for slave devices.

- Slave-related specifications

This section contains all slave-related specifications, such as the number and type of I/O channels, specification of diagnostic texts and information on the available modules with modular devices. In the individual sections, the parameters are separated by key words. A distinction is made between mandatory parameters (i.e., Vendor_Name) and optional parameters (i.e., Sync_Mode_supported). The definition of parameter groups allows selection of options. In addition, bit map files with the symbols of the devices can be integrated. The format of the GSD is designed for flexibility. It contains both lists (such as the baud rates supported by the device) as well as space to describe the modules available in a modular device. Plain text can also be assigned to the diagnostic messages.

A.3.4 PROFINET---Void

A.4 CPF 4 (P-NET) communication concepts

The P-NET Fieldbus is designed to connect distributed process components like process computers, intelligent sensors, actuators, I/O modules, field and central programmable controllers, etc., via a common two wire cable. Beyond being used for transmitting process data, P-NET is also used for data collection, for configuration of nodes/sensors, and for downloading of programs.

The typical P-NET application requires response times measured in ms, and a bus length up to one km or more. There are other types of applications which demand a response time measured in μ s. For these applications P-NET is not appropriate. P-NET applications are found in the process industry environment and in discrete parts manufacturing plants. P-NET is as well suited for small plants, as for large plants having many controllers, sensors, and interface modules. In addition, any such system is always ready for any necessary expansion.

P-NET can handle up to 300 confirmed data transactions per second, from 300 independent addresses. Data can be transferred in the form of fully processed values (floating point), such as temperature, pressure etc., or as for example blocks of 32 independent binary signals, indicating valve states, switch positions etc. This results in a performance of up to 9,600 binary signals per second being accessed from anywhere within the complete system.

The result of a measurement made by a responder is presented to an initiator in a pre-processed form, for example in SI (metric) engineering units. This means, that no repetitive scaling or conversion needs to be done by the initiator(s).

The physical layer of P-NET can be based on the RS-485 standard using a shielded twisted pair cable. This allows a cable length of up to 1 200 m without repeaters. P-NET devices are galvanically isolated, and up to 125 devices per link can be connected. P-NET is a multi-master bus, which can accept up to 32 initiators per link. All communication is based on the principle, where an Initiator sends a request, and the addressed Responder returns an immediate response.

The right to access the link is transferred from one P-NET initiator to another, by means of a token. P-NET uses a method called “virtual token passing”, which does not require messages to be sent over the link.

P-NET allows direct addressing between several links, also known as a multi-link structure. This feature is a specified part of the P-NET protocol, and it can be built into the standard operating system of multi-port initiators. Communication is directed through the different links via devices with two or more P-NET ports. This means that any initiator on one link can transparently access any device within any other link, without the need for special programming in the multi-port devices. The benefits gained by dividing a system into smaller sections are highly significant, because it limits the consequences of an error to a single link, which gives higher system security. Furthermore, the multi-link structure provides a natural redundancy. There is no hierarchical structuring of the links. This is of great benefit when expanding existing P-NET installations, and when coupling to other networks.

Any P-NET device, including an initiator, can be powered down or connected to or disconnected from the link, without interfering with the rest of the system. Consequently, devices can be exchanged during system operation, and a system can be expanded while the remaining production system continues to run.

Implementation of the P-NET protocol requires very little program space. Typically, a simple class device P-NET implementation requires approximately 4 Kbytes of program space when written in “C”.

Programmable P-NET modules that include an Ethernet port have been made available, where the in-built operating system provides transparent P-NET communication between two points connected locally or via the Internet. Standardized Ethernet wiring and connectors also provide the means of interconnection of switches, to avoid media access collisions, and wireless access points and routers (WLAN), as a highly convenient media alternative. When connecting two or more industrial networks together using this method, it will, more often than not, contain real-time measurement or process data. This technology is therefore now referred to as Real Time Ethernet (RTE). In essence, the P-NET protocol and message structure has not been changed. What happens, is that the familiar message structure used, say via RS 485, is 'wrapped' in a 'user datagram' using the transport protocol within IP called UDP. Using this technology, it is necessary to define specific usage ports as a means of defining the underlying message protocol (i.e. P-NET). The P-NET on IP extensions to the current P-NET standard includes a description of the structure of UDP/IP packages for P-NET messages. These enhance current definitions of P-NET message addressing modes (e.g. simple, extended, complex) with IP, including associated routing definitions. Implementation of P-NET on IP for Real Time Ethernet, means that P-NET packages can be routed through IP networks in exactly the same way as they can be routed through non-IP networks. Routing can be through any type of P-NET network and in any order. Nodes on an IP network are addressed with two P-NET Route elements, but this is entirely handled by the IP nodes. This means that any P-NET client (master) can access servers on an IP network, without knowing anything about IP addresses.

A.5 CPF 5 (WorldFIP) communication concepts

A.5.1 Physical layer characteristics

The physical layer provides communication over shared broadcast physical media operating at a common data rate, composed of either or both

- a) twisted-pair with taps integral to the bus couplers;
- b) paired fiber optic cables connected through one or more star couplers.

The low-speed low-grade media of A.1.2.1 are also supported, for use where appropriate.

A.5.2 Data-link layer characteristics

The data-link layer (DLL) provides coordinated access to the shared physical medium. Its major features are:

- a) cyclic scheduled access to various devices to multicast (produce) information in a predetermined order, and to notify the scheduler of their need for additional communication
- b) demanded access by any active device, to request or to send information whose transmission is not scheduled

The DLL provides

- 1) point-to-multipoint operation using configured connections and current-message buffers,
- 2) point-to-point acknowledged connectionless operation, and
- 3) (multi)point-to-multipoint unacknowledged connectionless operation

Both of the latter use FIFO message queues. Bridging of all three types of communication is specified; data originating from current-message buffers 1) is rebuffered within the bridges.

A.5.3 Application layer characteristics

The application layer (AL) provides services to determine for each message or message set

- the timeliness of the message,
- the temporal consistency of multiple messages, and
- the spatial consistency of message sets across multiple devices.

The AL provides either full MMS (ISO/IEC 9506) or a performance-enhanced feature-reduced subset, depending on the profile.

A.6 CPF 6 (INTERBUS) communication concepts

A type 8 (INTERBUS) network is a digital serial communication system with a central master-slave access method and ring topology. The master starts the first network segment – a group of devices – which could be extended with further network segments by bus couplers. Slaves and bus couplers do not carry an address, they are addressed implicitly by their position on the ring.

The application layer is based on the concepts of Type 9, it uses the object model as well as the structure of protocol machines. Special optimized encoding rules (PER – Peripherals Encoding Rules) are used, which ensure that the PDUs are fully compliant to the existing INTERBUS specification. Two communication mechanisms are offered to the AL user:

- cyclic transmission of data (for process data) in a high efficient manner using a push publisher/subscriber model

ARPM: Buffered Network-Scheduled Uni-directional (BNU)

- non cyclic transmission of data (for parameter data) using a client server communication model, both master and slave can act either as client or server
ARPM: Queued User-triggered Bi-directional with Flow Control (QUB-FC), or
ARPM: Queued User-triggered Bi-directional – Transparent Mode (QUB-TM)

The DLL protocol provides means of optimized, concurrent interchange of fixed length input/output data (process data channel) and variable length segmented messages (parameter channel). It uses a summation frame to exchange data in full duplex. This special protocol meets two requirements, which are very important in fieldbus applications. The first requirement is the capability of the network to scan the input/output data in a time-constant and consistent way, and the second is a high protocol efficiency, which is much higher at the same transmission rate than those of message oriented communication systems.

For every slave device a fixed time slot according to its data width is allocated in the frame. The data package order is according to the physical order of the connected devices. Cyclic data (process data) and non cyclic data (parameter data) are transferred concurrently. Devices with parameter data use a fixed length of 2, 4 or 8 octets in the summation-frame, longer messages (PDUs) are segmented by the DLL. Therefore the frame length is constant for a given configuration and not affected by the message transfer.

A transmission cycle is initiated by the master and starts with a data sequence, this contains the loop back word followed by the output data. While output data are send from the master to the slaves, input data are send concurrently from the slaves to the master. After output of the summation frame all output data is correctly positioned in the devices.

The subsequent 32-bit long frame check sequence serves to verify the transmitted data. This is carried out by a 16-bit CRC polynomial. Due to the point to point structure, the error checking mechanism always takes place between two devices. Controlled by the frame check sequence, the exchange and comparison is carried out simultaneously for all devices, thus only the overhead of one CRC check word is needed for the whole frame. The second 16 bits are used to transmit the check sum status. If the check sum status shows no error the Buffer Received Indication is given.

Slaves and bus couplers have a device code, which contains the basic communication capabilities of this device. This includes the communication channel, process data and/or parameter channel support, as well as bit occupation (data width) in the summation frame. The master uses identification cycles to read the device codes of all connected devices to establish the current configuration.

The physical layer definition comprises the definition of the physical characteristics of (point to point) connections between the connected devices.

Three devices types are distinguished:

- Master
The master starts the first network segment. It centrally controls the data traffic, sends the summation frame, with data to all slaves and, at the same time, receives data from the latter. The master causes the slaves to access the bus, i.e. to send or receive data.
- Slave
A slave is connected in an existing network segment. It receives data from its preceding device and sends data to the following device. A slave removes its incoming data from the summation frame and inserts its outgoing data in this place, any other data are bypassed.
- Bus coupler
A bus coupler is connected in an existing network segment and has an additional interface to start another, lower level, network segment. Incoming data, from the higher level network segment, are transmitted to the first device of the lower level network

segment, these data are looped back from the last device of this network segment. The received data from the lower level network segment are transmitted to the following device of the higher level network segment.

To simplify system installation and system diagnostics, the ring system can be implemented into one single cable, so that the topology resembles a bus system with branching lines. In this case the ring is closed automatically in the last slave of a network segment, and the data are looped back via additional interface circuits in each device. This allows adding devices to and removing them from the network.

A.7 CPF 8 (CC-LINK) communication concepts

A.7.1 Basic characteristics

CC-Link defines the technical characteristics of a serial fieldbus system with which distributed digital programmable controllers can be networked, from field level to cell level. CC-Link is a master-slave system with three basic phases of operation:

- a) Initial cycle
- b) Refresh cycle
- c) Return cycle

A.7.1.1 Initial cycle

After power up sequencing, all devices enter the initial cycle, whereupon Master devices search for, and attempt establishing connections with, all the Slave devices connected to the bus. Slave devices power up with process i/o data in safe states as specified in their configurations while they establish a connection with a Master. The Master completes connection establishment then verifies the configuration of the network and all the connected Slave devices.

A.7.1.2 Refresh cycle

Once configurations are validated, the network enters the refresh cycle where the Master device scans its Slave devices by sending output, and receiving input, cyclic i/o process data. Where systems support acyclic messaging, when requested, a Master device includes acyclic message request data addressed to a Slave at the end of its cyclic data transmission. The appropriately capable Slave device responds by including acyclic message response data at the end of its cyclic data transmission to the Master. Only a Master device is able to initiate acyclic messaging.

A.7.1.3 Return cycle

If the Master device determines that one or more Slave devices have timed-out or repeatedly responded with erroneous data, it places the offending Slave in a list of devices that require reconnection. If one or more Slave devices are included in this list, the Master will alternate every other completed refresh cycle with attempts to re-establish connections to all of the offending Slave device(s). One time through this re-establish connections process called a return cycle.

A.7.2 Variants

There are two primary variants of a CC-Link system:

- CC-Link — a high-speed serial, cyclic i/o data and acyclic messaging network.
- CC-Link/LT — a bus-powered low-cost serial, cyclic i/o data network.

CP 8/1 and CP 8/2 describe CC-Link (CC-Link and CC-Link V2 respectively) and CP 8/3 describes CC-Link/LT.

CC-Link uses a PhL with a balanced transmission signal over a shielded 3-core twisted cable. Communication data rates as high as 10 mbps and transmission distances as long as 1 200 m are specified. CC-Link V2 adds to CC-Link extended frames which make use of segmented cyclic data to transmit larger structures of i/o process data for larger systems.

CC-Link/LT uses a bus-powered PhL (devices receive power from the bus) with a balanced transmission signal over a 4-core unshielded cable in both flat and round configurations. Communication data rates as high as 2,5 mbps and transmission distances as long as 500 m are specified. CC-Link/LT is intended for simpler and more cost effective systems.

A.8 CPF 9 (HART) communication concepts

A CPF 9 (HART) communication system is designed to transmit process data, diagnostics, status, and configuration parameters between intelligent process measurement and control field devices and industrial process automation systems, programmable control systems, hand-held terminals and computer software applications. Two-way HART digital communication is transmitted simultaneously and on the same wiring with the 4 mA to 20 mA current loop analog communication channel commonly used by process instrumentation. The HART application layer defines the content and format of data to be transmitted along with standard procedures for diagnostics, commissioning and maintenance. The Universal Command set shall be implemented in all field devices.

A.9 CPF 16 (SERCOS) communication concepts

CPF 16 (SERCOS) provides for communication between a master and several slave devices. Master telegrams are not addressed individually to each device; they are instead common to all devices. Slots within these telegrams are individually allotted to each device. The device may then read in its slot the data that is addressed specifically to it by the master; likewise it may also write data that it addresses to the master. The slot allocation is defined by the master during initialization, depending upon configuration. Other transmission modes are available for data that do not have to fulfill strict real-time requirements.

SERCOS allows for synchronization during cyclic data transmission. Depending on the configuration, the operating cycle of the master may be synchronized with the communication cycle and with the operating cycle of the devices. In that way, beats between individual cycles can be prevented and latency delays can be reduced to a minimum. Device output signals may become active and device input signals may be sampled concurrently in all devices.

SERCOS is not just a data transmission system. It provides a large number of data and procedure commands which can be used, i.e. for the operation of machines. All data, procedure commands, and all supplementary information are summarized in data blocks, which contain each an identification number (IDN), a name, attributes, units, minimum and maximum input values as well as the data itself. Several of them are specified in application-specific standards (e.g., IEC 61800-7-204 for power drive systems).

CP16/1 and CP16/2 physical layers are based on fiber optic hardware. The topology shall be a ring structure (see Figure A.1).

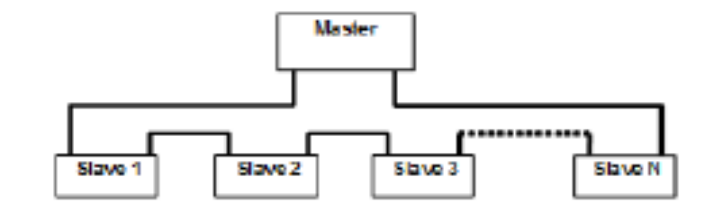

Figure A.1 – Ring structure

A master device may have one or more master interfaces depending on configuration. Each master interface handles only one network on the physical layer as well as in the overlying protocol layers.

NOTE Figure A.2 shows a topology example in the field of power drive systems as specified in IEC 61800-7-204. The application specific terms used in this figure are not defined in this standard.

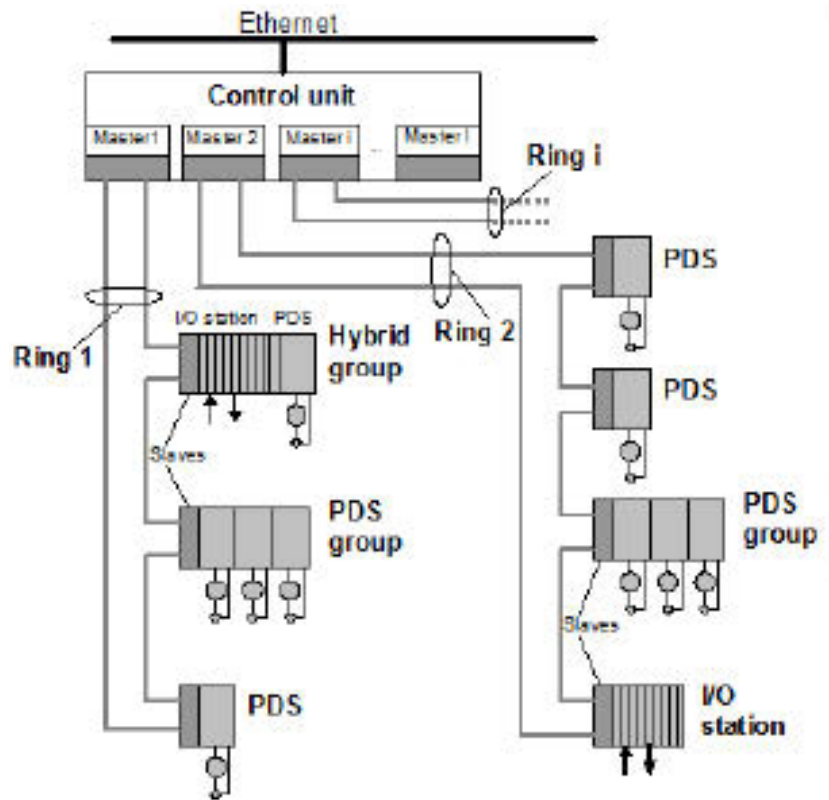

Figure A.2 – Topology example

CP16/1 and CP16/2 communication cycle times may be selected between 62,5 μ s, 125 μ s, 250 μ s or any integer multiple of 250 μ s. The exact number of devices which can be serviced by a network depends on the cycle time, the selected data volume, and the transmission rate. The following details (see Table A.1) are valid under normal operating conditions.

Table A.1 – Number of devices per CP16/1 and CP16/2 systems (examples)

Cycle time	Data record per device (cyclic data)	Transmission rate	Number of devices	Data rate per device (non-cyclic data)	Spare time
2 ms	32 bytes	2 Mbit/s	8	8 kbit/s (2 bytes)	390 μ s
1 ms	32 bytes	4 Mbit/s	8	16 kbit/s (2 bytes)	125 μ s
1 ms	36 bytes	8 Mbit/s	15	32 kbit/s (4 bytes)	208 μ s
0,5 ms	36 bytes	16 Mbit/s	14	128 kbit/s (8 bytes)	113 μ s
2 ms	16 bytes	16 Mbit/s	112	8 kbit/s (2 bytes)	330 μ s

Annex B (informative)

Added value of IEC 61784-1

The approval of the IEC 61784-1 as an International Standard means that a number of industry specifications for field communication have well-defined communication stacks (physical layer, data-link layer, application layer).

The added value of IEC 61784-1 is that:

- It is the guideline to properly use the IEC 61158 series of International Standards.
- The communication profiles are fully defined and available as International Standards.
- Devices declared fully compliant with one of these profiles are usable on the same network (they support the basic level of interoperability).
- Compliance may be supported by independent organizations.
- It gives the possibility to reference other existing national and international standards, where neither IEC nor ISO have equivalent standards.
- The harmonization work done in the IEC 61158 series resulted in the identification of some common views, concepts, definitions, and approaches. This helps understand the basis of fieldbus technologies.
- This International Standard specifies the different fieldbus concept in one document. This is a first and important step forward in resolving difficulty in comparing market products and performances.

The communication profiles give the normative basis needed to support the complementary work about the application functions, which is being developed in IEC/TC 65/WG 6 and IEC/SC 65C/WG 7).

Bibliography

IEC 60079-14, *Explosive atmospheres – Part 14: Electrical installations design, selection and erection*

IEC 60793 (all parts), *Optical fibres*

IEC 60807-3, *Rectangular connectors for frequencies below 3 MHz – Part 3: Detail specification for a range of connectors with trapezoidal shaped metal shells and round contacts – Removable crimp contact types with closed crimp barrels, rear insertion/rear extraction*

IEC 61131-3, *Programmable controllers – Part 3: Programming languages*

IEC 61158-1, *Industrial communication networks – Fieldbus specifications – Part 1: Overview and guidance for the IEC 61158 series*

IEC 61800-7-204, *Adjustable speed electrical power drive systems – Part 7-204: Generic interface and use of profiles for power drive systems – Profile type 4 specification*

ISO/IEC TR 10000-1, *Information technology – Framework and taxonomy of International Standardized Profiles – Part 1: General principles and documentation framework*

ISO/IEC 10731, *Information technology – Open Systems Interconnection – Basic Reference Model – Conventions for the definition of OSI services*

ISO/IEC 2022, *Information technology – Character code structure and extension techniques*

ISO/IEC 3309, *Information technology – Telecommunications and information exchange between systems – High-level data link control (HDLC) procedures – Frame structure¹⁷*

ISO/IEC 7498-1, *Information technology – Open Systems Interconnection – Basic Reference Model: The Basic Model*

ISO/IEC 7498-3, *Information technology – Open Systems Interconnection – Basic Reference Model: Naming and addressing*

ISO 9506-1, *Industrial automation systems – Manufacturing Message Specification – Part 1: Service definition*

ISO 9506-2, *Industrial automation systems – Manufacturing Message Specification – Part 2: Protocol specification*

ISO 11898 (all parts), *Road vehicles – Controller area network (CAN)*

ISO 11898-1, *Road vehicles – Controller area network (CAN) – Part 1: Data link layer and physical signalling*

ISO 11898-2, *Road vehicles – Controller area network (CAN) – Part 2: High-speed medium access unit*

¹⁷ Withdrawn

ANSI TIA/EIA 422-B:1994, *Electrical Characteristics of Balanced Voltage Digital Interface Circuits*

ITU-T V.11, *Electrical characteristics for balanced double-current interchange circuits operating at data signaling rates up to 10 Mbit/s*

ODVA: THE CIP NETWORKS LIBRARY – Volume 1: *Common Industrial Protocol (CIP™) – Edition 3.13, November 2012*; available at <<http://www.odva.org>>

ODVA: THE CIP NETWORKS LIBRARY – Volume 2: *EtherNet/IP™ Adaptation of CIP – Edition 1.14, November 2012*; available at <<http://www.odva.org>>

ODVA: THE CIP NETWORKS LIBRARY – Volume 3: *DeviceNet™ Adaptation of CIP – Edition 1.12, November 2011*; available at <<http://www.odva.org>>

ODVA: THE CIP NETWORKS LIBRARY – Volume 4: *ControlNet™ Adaptation of CIP – Edition 1.7, April 2011*; available at <<http://www.odva.org>>

British Standards Institution (BSI)

BSI is the national body responsible for preparing British Standards and other standards-related publications, information and services.

BSI is incorporated by Royal Charter. British Standards and other standardization products are published by BSI Standards Limited.

About us

We bring together business, industry, government, consumers, innovators and others to shape their combined experience and expertise into standards-based solutions.

The knowledge embodied in our standards has been carefully assembled in a dependable format and refined through our open consultation process. Organizations of all sizes and across all sectors choose standards to help them achieve their goals.

Information on standards

We can provide you with the knowledge that your organization needs to succeed. Find out more about British Standards by visiting our website at bsigroup.com/standards or contacting our Customer Services team or Knowledge Centre.

Buying standards

You can buy and download PDF versions of BSI publications, including British and adopted European and international standards, through our website at bsigroup.com/shop, where hard copies can also be purchased.

If you need international and foreign standards from other Standards Development Organizations, hard copies can be ordered from our Customer Services team.

Subscriptions

Our range of subscription services are designed to make using standards easier for you. For further information on our subscription products go to bsigroup.com/subscriptions.

With **British Standards Online (BSOL)** you'll have instant access to over 55,000 British and adopted European and international standards from your desktop. It's available 24/7 and is refreshed daily so you'll always be up to date.

You can keep in touch with standards developments and receive substantial discounts on the purchase price of standards, both in single copy and subscription format, by becoming a **BSI Subscribing Member**.

PLUS is an updating service exclusive to BSI Subscribing Members. You will automatically receive the latest hard copy of your standards when they're revised or replaced.

To find out more about becoming a BSI Subscribing Member and the benefits of membership, please visit bsigroup.com/shop.

With a **Multi-User Network Licence (MUNL)** you are able to host standards publications on your intranet. Licences can cover as few or as many users as you wish. With updates supplied as soon as they're available, you can be sure your documentation is current. For further information, email bsmusales@bsigroup.com.

BSI Group Headquarters

389 Chiswick High Road London W4 4AL UK

Revisions

Our British Standards and other publications are updated by amendment or revision.

We continually improve the quality of our products and services to benefit your business. If you find an inaccuracy or ambiguity within a British Standard or other BSI publication please inform the Knowledge Centre.

Copyright

All the data, software and documentation set out in all British Standards and other BSI publications are the property of and copyrighted by BSI, or some person or entity that owns copyright in the information used (such as the international standardization bodies) and has formally licensed such information to BSI for commercial publication and use. Except as permitted under the Copyright, Designs and Patents Act 1988 no extract may be reproduced, stored in a retrieval system or transmitted in any form or by any means – electronic, photocopying, recording or otherwise – without prior written permission from BSI. Details and advice can be obtained from the Copyright & Licensing Department.

Useful Contacts:

Customer Services

Tel: +44 845 086 9001

Email (orders): orders@bsigroup.com

Email (enquiries): cservices@bsigroup.com

Subscriptions

Tel: +44 845 086 9001

Email: subscriptions@bsigroup.com

Knowledge Centre

Tel: +44 20 8996 7004

Email: knowledgecentre@bsigroup.com

Copyright & Licensing

Tel: +44 20 8996 7070

Email: copyright@bsigroup.com



...making excellence a habit.™