

Fibre optic interconnecting devices and passive components — Interface standard for closures —

Part 1: General and guidance

ICS 33.180.20

National foreword

This British Standard is the UK implementation of EN 61758-1:2008. It is identical to IEC 61758-1:2008.

The UK participation in its preparation was entrusted by Technical Committee GEL/86, Fibre optics, to Subcommittee GEL/86/2, Fibre optic interconnecting devices and passive components.

A list of organizations represented on this committee can be obtained on request to its secretary.

This publication does not purport to include all the necessary provisions of a contract. Users are responsible for its correct application.

Compliance with a British Standard cannot confer immunity from legal obligations.

This British Standard was published under the authority of the Standards Policy and Strategy Committee on 30 September 2008

© BSI 2008

ISBN 978 0 580 54795 9

Amendments/corrigenda issued since publication

Date	Comments

**Fibre optic interconnecting devices and passive components -
Interface standard for closures -
Part 1: General and guidance
(IEC 61758-1:2008)**

Dispositifs d'interconnexion
et composants passifs à fibres optiques -
Norme d'interface pour boîtiers -
Partie 1: Généralités et lignes directrices
(CEI 61758-1:2008)

Lichtwellenleiter - Verbindungselemente
und passive Bauteile -
Schnittstellennorm für Muffen -
Teil 1: Allgemeines und Leitfaden
(IEC 61758-1:2008)

This European Standard was approved by CENELEC on 2008-06-01. CENELEC members are bound to comply with the CEN/CENELEC Internal Regulations which stipulate the conditions for giving this European Standard the status of a national standard without any alteration.

Up-to-date lists and bibliographical references concerning such national standards may be obtained on application to the Central Secretariat or to any CENELEC member.

This European Standard exists in three official versions (English, French, German). A version in any other language made by translation under the responsibility of a CENELEC member into its own language and notified to the Central Secretariat has the same status as the official versions.

CENELEC members are the national electrotechnical committees of Austria, Belgium, Bulgaria, Cyprus, the Czech Republic, Denmark, Estonia, Finland, France, Germany, Greece, Hungary, Iceland, Ireland, Italy, Latvia, Lithuania, Luxembourg, Malta, the Netherlands, Norway, Poland, Portugal, Romania, Slovakia, Slovenia, Spain, Sweden, Switzerland and the United Kingdom.

CENELEC

European Committee for Electrotechnical Standardization
Comité Européen de Normalisation Electrotechnique
Europäisches Komitee für Elektrotechnische Normung

Central Secretariat: rue de Stassart 35, B - 1050 Brussels

Foreword

The text of document 86B/2683/FDIS, future edition 1 of IEC 61758-1, prepared by SC 86B, Fibre optic interconnecting devices and passive components, of IEC TC 86, Fibre optics, was submitted to the IEC-CENELEC parallel vote and was approved by CENELEC as EN 61758-1 on 2008-06-01.

The following dates were fixed:

- latest date by which the EN has to be implemented at national level by publication of an identical national standard or by endorsement (dop) 2009-03-01
- latest date by which the national standards conflicting with the EN have to be withdrawn (dow) 2011-06-01

Annex ZA has been added by CENELEC.

Endorsement notice

The text of the International Standard IEC 61758-1:2008 was approved by CENELEC as a European Standard without any modification.

CONTENTS

1	Scope	5
2	Normative references	6
3	Terms, definitions and abbreviations	7
3.1	Terms and definitions	7
3.2	Abbreviations	8
4	General description	8
4.1	Functional requirements	8
4.2	Environmental requirements	8
4.3	Functional closure parts	9
4.3.1	Primary function	9
4.3.2	Cover functional requirements	9
4.3.3	Base or end plate functional requirements	9
4.3.4	Opening and closing functional requirements	9
4.3.5	Closure seal functional requirements	9
4.3.6	General functional requirements	10
5	Closure overpressure safety	10
6	Grounding interface	10
7	General closure interfaces	10
8	Cable to closure interface	10
8.1	General	10
8.2	Functional requirements	10
8.2.1	General	10
8.2.2	Cable entry port	11
8.2.3	Repair, maintenance and testing	11
8.2.4	Moisture and gas ingress, sealing and blocking	11
8.2.5	Mechanical impacts	12
8.2.6	Cable and closure handling	12
8.2.7	Electrical continuity and lightning protection	12
8.2.8	Fire-related performance	12
8.2.9	Identification of cables and sub-parts	12
8.2.10	Biotic protection	12
8.2.11	Cable anchoring and supporting elements to closure	13
8.2.12	UV resistance	13
8.2.13	Resistance to aggressive media	13
9	Closure to FMS interface	13
9.1	General	13
9.2	Functional requirements	13
9.2.1	Mounting of the FMS to the closure	13
9.2.2	Identification	13
9.2.3	Access to FMS	14
9.2.4	Bending radius	14
9.2.5	Mechanical impacts	14
9.2.6	FMS grounding	14

- 9.2.7 Fire hazard (optional for indoor applications) 14
- 9.2.8 Laser safety..... 14
- 9.2.9 High optical power damage 14
- 10 Other parts of the closure interface 15
 - 10.1 General 15
 - 10.2 Passive components that may be included in a closure 15
 - 10.2.1 xWDM 15
 - 10.2.2 Moisture sensors 15
 - 10.2.3 Security features 15
 - 10.2.4 Connectors and adaptors..... 15
 - 10.2.5 Pressure relief valves 15
 - 10.2.6 Splitters/couplers..... 15
 - 10.2.7 Optical switches 16
 - 10.2.8 Desiccant 16
 - 10.3 Active components that may be included in a closure 16
 - 10.3.1 Moisture sensors 16
 - 10.3.2 Security alarms..... 16
 - 10.3.3 Optical switches 16
 - 10.3.4 Converters..... 16
- 11 Closure interface to external siting 16
 - 11.1 Functional requirements 16
 - 11.2 Mounting of the closure to the external siting..... 16
 - 11.3 Cable entry orientation 16
 - 11.4 Identification..... 16
 - 11.5 Access to closure and cable 16
 - 11.6 Earthquake resistance..... 17
 - 11.7 Closure grounding 17
 - 11.8 Lightning protection..... 17
 - 11.9 Fire hazard (optional for indoor applications)..... 17
 - 11.10 External siting of closure in aerial applications 17
- Annex ZA (normative) Normative referencenes to international publications with their
corresponding European publications 19
- Bibliography..... 18
- Figure 1 – Closure and FMS functions 6

FIBRE OPTIC INTERCONNECTING DEVICES AND PASSIVE COMPONENTS – INTERFACE STANDARD FOR CLOSURES –

Part 1: General and guidance

1 Scope

This part of IEC 61758 provides general information and guidance on the subject of closures. It includes references, general closure and interface descriptions and definitions.

This standard defines the following general interfaces for closures:

- interface to cables;
- interface to FMS;
- interface to parts other than FMS or cables;
- interface to external sitings (pits, manholes etc.)

This specification covers all types of closures. The performance requirements are given in IEC 61753-111 series (in preparation).

This closure standard allows both single mode and multi-mode fibre to be used, and covers all IEC standard optical fibre cables as listed in Clause 2, with their various fibre capacities, types and designs.

Figure 1 shows and defines the interface between the closure and the fibre management system.

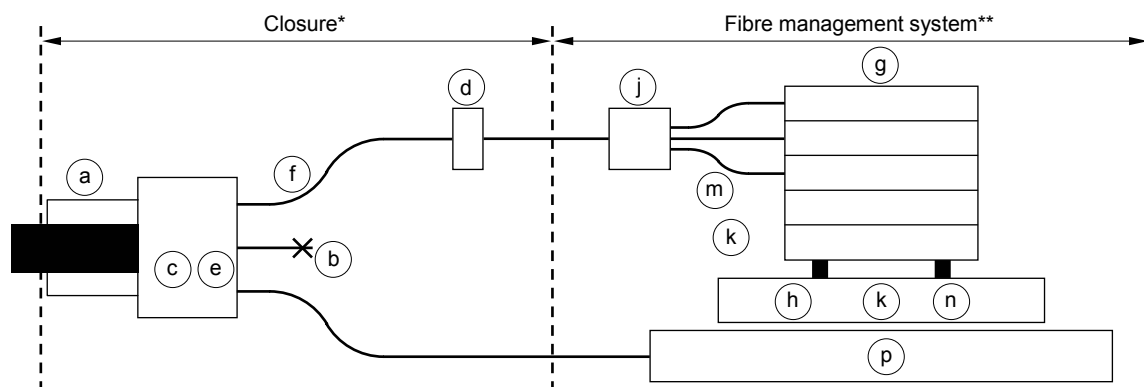

IEC 532/08

Key

Closure functions*

- (a) Cable sealing
- (b) Cable anchorage
- (c) Cable blockage
- (d) Cable gas blocking
- (e) Distribution element
- (f) Identification

FMS functions**

- (g) Organiser/splice tray(s)
- (h) Fibre storage
- (j) Distribution element
- (k) Passive components
- (m) Guiding elements
- (n) Connectors
- (p) Cable element storage

* Example of Closure

** Example of FMS

Figure 1 – Closure and FMS functions**2 Normative references**

The following referenced documents are indispensable for the application of this document. For dated references, only the edition cited applies. For undated references, the latest edition of the referenced document (including any amendments) applies.

IEC 60068-3-3, *Environmental testing – Part 3: Guidance – Seismic test methods for equipment*

IEC 60721-2-6, *Classification of environmental conditions – Part 2: Environmental conditions appearing in nature – Earthquake vibration and shock*

IEC 60793-2 (all parts), *Optical fibres – Part 2: Product specifications*

IEC 60794-2 (all parts), *Optical fibre cables – Part 2: Indoor cables*

IEC 60794-3 (all parts), *Optical fibre cables – Part 3: Outdoor cables*

IEC 60825-2, *Safety of laser products – Part 2: Safety of optical fibre communication systems (OFCS)*

IEC 61300 (all parts), *Fibre optic interconnecting devices and passive components – Basic test and measurement procedures*

IEC 61753 (all parts), *Fibre optic interconnecting devices and passive components performance standard*

IEC 61753-1, *Fibre optic interconnecting devices and passive components performance standard – Part 1 – General and guidance for performance standards*

IEC 61756-1, *Fibre optic interconnecting devices and passive components – Interface standard for fibre management systems – Part 1: General and guidance*

IEC/TR 62222, *Fire performance of communication cables installed in buildings*

3 Terms, definitions and abbreviations

3.1 Terms and definitions

3.1.1

ancillary components

components that are used for functions other than optical transmission

3.1.2

closure

all external housings except outdoor cabinets

3.1.3

enclosure

indoor housings (cabinets, cases, distribution frames) and outdoor cabinets

3.1.4

housing

closure or enclosure

3.1.5

intervention

opening the cover, modifying, adding, removing or repairing fibre circuits, splices, connectors or other components between the incoming and outgoing cables of an existing fibre management system

3.1.6

optical node

a point of intervention in the network, e.g. at each opening of a cable jacket or at the end of the cable

NOTE Nodes in this specification are parts of the physical network containing closures and fibre management systems capable of performing their expected function in the network, while exposed to the environment that they are intended to reside in.

3.1.7

fibre management system

system to control, protect and store fibres from the incoming to the outgoing fibres

[IEC 61756-1, definition 3.1.4]

3.1.8

active optical component

optical component or assembly which makes use of quantum-mechanical effects or generates optical gain of signal power, or directly modulates optical signals

NOTE 1 Examples include optical amplifiers.

NOTE 2 Sometimes optical sources and optical detectors have been designed as active optical components. [IEC 61756-1, definition 3.1.14].

3.1.9

passive optical component

an optical component or assembly which does not require any source of energy for its operation other than optical input signals, or controls the dynamic or static characteristics of optical signals using a source of energy; an optical passive component never generates an optical gain of signal power

NOTE 1 Examples include optical attenuators and passive branching devices.

NOTE 2 Photo diode, which is an active component used as simple signal monitoring, might be treated as a passive optical component.

[IEC 61756-1, definition 3.1.15]

3.1.10

external siting

mounting location for closures

3.2 Abbreviations

FMS: fibre management system

xWDM: wavelength division multiplexing device (DWDM, CWDM, etc.)

4 General description

4.1 Functional requirements

The general function of the closure is to provide:

- a housing for a fibre management system, including cable element storage, and ancillary passive or active components or other functional parts to build an optical node;
- a management system for the external environment, e.g. subterranean chambers, aerial poles and street cabinets;
- environmental and mechanical protection.

The following ancillary passive and active optical components may be stored or installed in the closure, but outside of the fibre management system or other functional parts of the optical node:

- electronic sensors and ancillary equipment for the detection of moisture ingress;
- communication electronic alarm devices and cable equipment for the transmission of signals to an external remote control station;
- grounding to earth of metallic parts of the structure and cables for operator safety.

4.2 Environmental requirements

The primary environmental requirements are:

- environmental protection;
- mechanical protection.

Environmental and mechanical protection prevents damage to the closure and protect internal closure components and assemblies from external environmental influences, including

temperature, humidity, vibration, impact, compression, torsion, bump, tension and aggressive and corrosive media.

Environmental performance tests are carried out to suit the installed environment. Each has an appropriate severity category listed in IEC 61300 and IEC 61753-1:

- S: subterranean (underground);
- A: aerial;
- G: ground level;
- C: controlled (in building).

4.3 Functional closure parts

4.3.1 Primary function

The primary function of the closure is to protect the fibre and other functional parts and to provide quick access to all internal components and assemblies.

The primary functional parts of the closure are:

- covers;
- base or end plates;
- closing parts;
- seals for the base or end plates.

4.3.2 Cover functional requirements

The closure cover requires the following features:

- sealing feature;
- means of attachment .

4.3.3 Base or end plate functional requirements

The primary function of the base or end plate is cable attachment and sealing.

The closure base or end plate requires the following features:

- sealing feature;
- means of attachment;
- cable entry ports.

4.3.4 Opening and closing functional requirements

The opening and closing function provides access to internal members, adequate closing force and structural strength.

The closure cover to base fixing requires the following features:

- secure fixing;
- sealing feature.

4.3.5 Closure seal functional requirements

The function of these parts of the closure is to form a gas and liquid resistant seal.

4.3.6 General functional requirements

In addition to the above the following functions shall be provided, where required, in each closure:

- ability to attach other structural parts;
- ability to fit an air pressure valve.

5 Closure overpressure safety

Overpressure can build up in sealed closures due to temperature differentials over a period of time, or due to tightness testing of the seals after installation or incorrect installation techniques.

Care should be taken when opening a sealed closure.

Provisions shall be made that overpressure is exhausted when opening the closure prior to complete removal of the cover.

For all sealed closures used for air blown fibre cable applications, a preset overpressure release system is required.

6 Grounding interface

When required by local regulations, metallic parts of the closure shall have a provision for electrical grounding, primarily for safety. Additional parts can be used to provide an external grounding.

7 General closure interfaces

This standard defines interfaces of:

- cable to closure interface;
- FMS to closure interface;
- other parts to closure interface;
- closure to external interface.

8 Cable to closure interface

8.1 General

Functional requirements of the cable to closure interface shall maintain the mechanical, electrical and environmental characteristics of the cable when cable sheath is removed. These interface specifications consider fibre types according to the IEC 60793-2 series and cable types in compliance with the IEC 60794-2 and IEC 60794-3 series.

8.2 Functional requirements

8.2.1 General

The interface requirements depend on the cable construction and environmental category.

The main function of the closure is to ensure the gas and water tightness of the fibre connections of two or more connected fibre optic cables. Furthermore the closure shall ensure

maintenance of the mechanical continuity the cables had before being interrupted. Different cable elements like sheath and strain relief member shall be fixed to the closure.

The interface between the cable and the closure as well as cable/closure installation technique shall be designed to minimize additional losses of the fibre optic link.

Cable termination fittings are an integral part of the cable installation technique and shall be considered also.

8.2.2 Cable entry port

Cable entry port is defined as the transition point from the fibre optic cable to the fibre optic cable termination. The cable entry port design depends on the cable type, in particular whether the cable sheath type is metallic or plastic. The dimensional correspondence between the cable and cable entry port diameter shall be defined according to the installation procedure and sealing technique.

The number, form and size of the entry port depend on the closure type facilities:

- joining;
- branching;
- distributing;
- joining of the cable and cable entry port;
- pressurised or non-pressurised cable installations;
- realisation of the gas and water tightness;
- crush and tensile stresses;
- shrinkage;
- expanding port capacity.

8.2.3 Repair, maintenance and testing

Repair and maintenance activities are necessary to allow upgrade of the fibre optic link as well as proper functionality of the fibre optic link during its lifetime. The cable termination procedure and accessories shall ensure the reinstall of the cable/closure connection with the same performance as before the repair and maintenance activities.

Repair and maintenance as well as the testing procedure depend on the optical network topology:

- ring;
- star;
- point to point;
- point to multipoint.

8.2.4 Moisture and gas ingress, sealing and blocking

Additional cable seals may provide the facility to prevent air, gas, water, cable grease or contaminants entering the closure through the cable. A frequent cause of fibre optic link failure is moisture ingress into the cable core. The following aspects shall be considered:

- sealing procedure between entry port and cable;
- cable seal (longitudinal seal).

8.2.5 Mechanical impacts

The possible mechanical impacts onto the cable/closure interface related to the cable entry port are as follows:

- tension or pressure (axial forces);
- shear (radial forces);
- bending;
- torsion.

8.2.6 Cable and closure handling

Cable and closure handling shall be designed to cover the following aspects:

- prevention of the moisture ingress;
- consideration of the mechanical strength of the cable;
- temperature and humidity during the mounting.

8.2.7 Electrical continuity and lightning protection

Optical fibre cables containing metallic elements are susceptible to induced voltages and being struck by lightning. Induced voltages and energy dissipated from the lightning strike on the metallic elements of cables can reach magnitudes which may cause damage to the cable and/or be a safety hazard to personnel in contact with the cable. Local regulations must be followed and some of the following aspects may be required:

- electrical interconnections between the cable metallic elements;
- all accessories for maintaining electrical continuity shall withstand the environmental impacts related to temperature, humidity and vibration;
- external grounding of the metallic components of the cables and metallic parts inside the closure;
- electrical continuity test access point, to verify that there is an adequate electrically conductive path.

8.2.8 Fire-related performance

The recommendations for the requirements and test methods to be specified for the fire performance of the cables when installed in buildings are defined in IEC TR 62222.

8.2.9 Identification of cables and sub-parts

The fibre and cable element identification for fibre splicing at cable joints or connecting at closures shall be defined. Fibre or cable elements shall be easily identified by colour, marking or position within the cable core.

The fibre and cable element identification marking shall be reliable:

- if a colouring method is used, the colours shall be clearly distinguishable;
- the colouring shall be stable in the presence of other materials and compatible with them during the lifetime of the cable;
- application technique shall not affect any transmission characteristic;
- the colouring or marking may be in the coating or applied to the surface of the coating.

8.2.10 Biotic protection

The material choice ensures that the external materials of the cable/closure joints do not support fungus or any other microbiotic growth.

8.2.11 Cable anchoring and supporting elements to closure

Cable anchoring is used to prevent excessive movement of all cable elements from tensile/compressive /torsion force and flexure.

Supporting elements shall ensure reliable and safe fastening of the cable at the closure:

- maximum and minimum bend radius;
- retaining of the tension and pressure forces.

Supporting elements may comprise the following:

- strain relief;
- ties;
- cable clamps;
- sealing elements (washer, grease etc.).

8.2.12 UV resistance

All polymeric materials at the outside of the closure shall be UV light resistant. The effect of UV light on polymeric materials shall be tested for closures of category A and G.

8.2.13 Resistance to aggressive media

All metallic parts of the closure shall be resistant to corrosive influences that may be encountered in the application environment. All polymeric materials of the outer closure shall be tested to determine their ability to withstand the severe conditions that could exist in the application area. The sealing performance of the closures and cable to closure interface in aggressive media shall be verified for category S, according to the performance requirements defined in the IEC 61753 series.

9 Closure to FMS interface

9.1 General

Functional requirements of the FMS to closure interface must maintain the optical and physical properties of the fibres inside the closure.

During reconfiguration the movement of the FMS, especially trays, should not affect the optical and physical properties of the fibres or other components.

This interface document covers FMS in compliance with IEC 61756 series.

9.2 Functional requirements

Closures may have the following function requirements if required by the application.

9.2.1 Mounting of the FMS to the closure

An FMS must be mounted on a closure frame in order to fulfil required closure performance (see the IEC 61753 series).

9.2.2 Identification

Identification of the cable and fibre is necessary, such as through a tag and colour code to identify each cable and fibre.

9.2.3 Access to FMS

It is necessary to manage and access fibres from the cable to FMS easily and safely.

The optical loss level during handling of live fibres will be found in the relevant performance specifications.

9.2.4 Bending radius

Fibre routing shall fulfil the requirements related to the bending radius.

Bending radius depends on the fibre type, but where the bending radius limits defined in IEC 61756-1 are not fulfilled this shall be clearly stated.

9.2.5 Mechanical impacts

After closures and FMS are installed on site, the following mechanical conditions may occur. The closure and FMS performance requirements related to the following mechanical conditions should be considered according to the performance standards defined in the IEC 61753 series:

- vibration;
- torsion;
- bending;
- axial and radial loads;
- crush resistance;
- impact.

9.2.6 FMS grounding

For safety reasons, where the FMS has metal parts, grounding must be considered”

The grounding method shall follow the regulations or laws in each region or each country where closures are installed. The details shall be agreed between the customer and supplier.

9.2.7 Fire hazard (optional for indoor applications)

For indoor applications, the fire-related performance shall be considered as follows:

- fire retardancy;
- halogen free;
- low smoke emission.

The fire hazard shall be handled according to IEC TR 62222 as well as specific regulations or laws in each region or each country where closures are installed. The details shall be agreed between the customer and supplier.

9.2.8 Laser safety

In the FMS optical power may be accessible. Hazard levels at accessible locations shall be assessed according to IEC 60825-2.

9.2.9 High optical power damage

Introduction of high optical power results in higher hazard levels (according to IEC 60825-2). These should be considered by the responsible organisation and persons.

Any high power damage is likely to affect the FMS reliability, and give rise to health and safety concerns.

10 Other parts of the closure interface

10.1 General

The following optional components may be installed within the closure but must not restrict the physical, optical, mechanical and operational performance of the FMS, closure or cable.

10.2 Passive components that may be included in a closure

10.2.1 xWDM

Wavelength division multiplexings are components for multiplexing the signal by transmitting at different wavelengths through the same fibre.

10.2.2 Moisture sensors

Humidity indicator paper: it changes colour to show presence of moisture. This can be attached within a closure to existing hardware where necessary (i.e. cobalt chloride paper).

Humidity sensor: it works with a moisture sensible tape or swelling body. If the tape or body comes into contact with humidity, it will expand and a bend-sensitive fibre is bent in a controlled way in order to generate a measurable increase of attenuation. This can be monitored by a suitable gauge.

10.2.3 Security features

Security features include:

- locking mechanism (i.e. a padlock, internal lock), which can be applied to the closure to restrict entry by unauthorised personnel;
- security tag;
- once the closure has been configured and sealed, a security tag can be attached to seal the closure. If the closure needs to be re-entered then the tag is cut and removed.

NOTE It is important to note when fitting an external lock to a closure that this could affect any external dimensions (see 'interface to external siting').

10.2.4 Connectors and adaptors

Adaptors are typically mounted to existing hardware within closures; additional adaptors may be added later. Care should be taken to observe minimum bend radius of the optical fibre.

10.2.5 Pressure relief valves

This is an optional device that is fitted to a closure to relieve overpressure. Increased pressure within a closure can be caused (but not defined) by the following:

- tightness testing of the seals;
- pressurised cable systems.

10.2.6 Splitters/couplers

Splitters or couplers are used to split or combine optical signals. They can be configured in a number of ways. They are typically mounted within the FMS, but may be mounted separately.

10.2.7 Optical switches

These are devices that route an optical signal from one or more input ports to one or more output ports. They do not require an outside power source.

10.2.8 Desiccant

A hygroscopic (water-absorbing) substance used in granulated form, typically supplied in a bag. This is placed inside the closure to remove moisture that is sealed within, preventing condensation.

10.3 Active components that may be included in a closure

10.3.1 Moisture sensors

A moisture sensor is a device used to detect moisture within a closure. These can then alert by means of an existing or dedicated cable.

10.3.2 Security alarms

Security alarms alert when a closure is opened. The alert may be audible or silent and can be connected via an existing cable or its own dedicated cable.

10.3.3 Optical switches

An optical switch is a device that routes an optical signal from one or more input ports to one or more output ports.

10.3.4 Converters

A converter is a repeater that also converts from one media type to another, such as from fibre to copper. It is often called a media adapter. It also applies to frequency conversion processes.

11 Closure interface to external siting

11.1 Functional requirements

Closures shall have the following functional requirements.

11.2 Mounting of the closure to the external siting

The installed closure shall be securely fixed to avoid uncontrolled movement.

11.3 Cable entry orientation

The entry orientation of cable is an important issue for interface definitions.

11.4 Identification

The identification of the cable and closure is necessary. This can be achieved using various identification methods.

11.5 Access to closure and cable

There is a need for sufficient cable length to allow the closure to be removed for maintenance and reconfiguration. The following aspects shall be considered:

- minimum bending radius of the cable shall be respected;

- handling of the closure shall not lead to the degradation of the transmission performance.

11.6 Earthquake resistance

In locations where closures are installed, the level and severity of earthquakes shall be evaluated to ensure that the enclosures continue to function to the required mechanical performance level according to IEC 60721-2-6 and IEC 60068-3-3.

Optional requirements for earthquake resistance testing when considering external siting of closures in aerial and underground applications are generally defined by local regulations and laws.

11.7 Closure grounding

For safety reasons, it is necessary to consider the grounding of closures when the closure contains metal parts.

The grounding method shall follow regulations or laws in each region or each country where closures are installed, and must be discussed and decided with carriers and users.

11.8 Lightning protection

For safety reasons, it is necessary to consider the grounding of closures externally to deflect or reduce the effects of a lightning strike.

Additional requirements for lightning protection, and testing when considering external siting of closures in aerial and above ground applications, are generally defined by local regulations and laws.

11.9 Fire hazard (optional for indoor applications)

The fire related performance must be considered as follows:

- fire retardancy;
- halogen free;
- low smoke emission.

The fire hazard shall be handled according to IEC TR 62222 as well as specific regulations or laws in each region or each country where closures are installed. The details shall be agreed between the customer and supplier.

11.10 External siting of closure in aerial applications

Local regulations and laws generally define the external siting of closures in aerial applications.

Bibliography

IEC 60050-731, *International Electrotechnical Vocabulary (IEV) – Chapter 731: Optical fibre communication*

IEC/TR 61931, *Fibre optic – Terminology*

IEC 62134 –1, *Fibre optic enclosures – Part 1: Generic specification*

NOTE Harmonized as EN 62134-1:2002 (not modified).

IEC Guide 109, *Environmental aspects – Inclusion in electrotechnical product standards*

Annex ZA
(normative)

**Normative references to international publications
with their corresponding European publications**

The following referenced documents are indispensable for the application of this document. For dated references, only the edition cited applies. For undated references, the latest edition of the referenced document (including any amendments) applies.

NOTE When an international publication has been modified by common modifications, indicated by (mod), the relevant EN/HD applies.

<u>Publication</u>	<u>Year</u>	<u>Title</u>	<u>EN/HD</u>	<u>Year</u>
IEC 60068-3-3	- ¹⁾	Environmental testing - Part 3: Guidance - Seismic test methods for equipments	EN 60068-3-3	1993 ²⁾
IEC 60721-2-6	- ¹⁾	Classification of environmental conditions - Part 2: Environmental conditions appearing in nature - Earthquake vibration and shock	HD 478.2.6 S1	1993 ²⁾
IEC 60793-2	Series	Optical fibres - Part 2: Product specifications	EN 60793-2	Series
IEC 60794-2	Series	Optical fibre cables - Part 2: Indoor cables	EN 60794-2	Series
IEC 60794-3 (mod)	Series	Optical fibre cables - Part 3: Outdoor cables	EN 60794-3	Series
IEC 60825-2	- ¹⁾	Safety of laser products - Part 2: Safety of optical fibre communication systems (OFCS)	EN 60825-2	2004 ²⁾
IEC 61300	Series	Fibre optic interconnecting devices and passive components - Basic test and measurement procedures	EN 61300	Series
IEC 61753	Series	Fibre optic interconnecting devices and passive components performance standard	EN 61753	Series
IEC 61753-1	- ¹⁾	Fibre optic interconnecting devices and passive components performance standard - Part 1: General and guidance for performance standards	EN 61753-1	2007 ²⁾
IEC 61756-1	- ¹⁾	Fibre optic interconnecting devices and passive components - Interface standard for fibre management systems - Part 1: General and guidance	EN 61756-1	2006 ²⁾
IEC/TR 62222	- ¹⁾	Fire performance of communication cables installed in buildings	-	-

¹⁾ Undated reference.

²⁾ Valid edition at date of issue.

British Standards Institution (BSI)

BSI is the independent national body responsible for preparing British Standards. It presents the UK view on standards in Europe and at the international level. It is incorporated by Royal Charter.

Revisions

British Standards are updated by amendment or revision. Users of British Standards should make sure that they possess the latest amendments or editions.

It is the constant aim of BSI to improve the quality of our products and services. We would be grateful if anyone finding an inaccuracy or ambiguity while using this British Standard would inform the Secretary of the technical committee responsible, the identity of which can be found on the inside front cover.
Tel: +44 (0)20 8996 9000 Fax: +44 (0)20 8996 7400

BSI offers members an individual updating service called PLUS which ensures that subscribers automatically receive the latest editions of standards.

Buying standards

Orders for all BSI, international and foreign standards publications should be addressed to Customer Services.

Tel: +44 (0)20 8996 9001 Fax: +44 (0)20 8996 7001

Email: orders@bsigroup.com

You may also buy directly using a debit/credit card from the BSI Shop on the Website <http://www.bsigroup.com/shop>.

In response to orders for international standards, it is BSI policy to supply the BSI implementation of those that have been published as British Standards, unless otherwise requested.

Information on standards

BSI provides a wide range of information on national, European and international standards through its Library and its Technical Help to Exporters Service. Various BSI electronic information services are also available which give details on all its products and services. Contact the Information Centre.

Tel: +44 (0)20 8996 7111 Fax: +44 (0)20 8996 7048

Email: info@bsigroup.com

Subscribing members of BSI are kept up to date with standards developments and receive substantial discounts on the purchase price of standards. For details of these and other benefits contact Membership Administration.

Tel: +44 (0)20 8996 7002 Fax: +44 (0)20 8996 7001

Email: membership@bsigroup.com

Information regarding online access to British Standards via British Standards Online can be found at <http://www.bsigroup.com/BSOL>.

Further information about BSI is available on the BSI website at <http://www.bsigroup.com>.

Copyright

Copyright subsists in all BSI publications. BSI also holds the copyright, in the UK, of the publications of the international standardization bodies. Except as permitted under the Copyright, Designs and Patents Act 1988 no extract may be reproduced, stored in a retrieval system or transmitted in any form or by any means – electronic, photocopying, recording or otherwise – without prior written permission from BSI.

This does not preclude the free use, in the course of implementing the standard, of necessary details such as symbols, and size, type or grade designations. If these details are to be used for any other purpose than implementation then the prior written permission of BSI must be obtained.

Details and advice can be obtained from the Copyright & Licensing Manager.

Tel: +44 (0)20 8996 7070 Email: copyright@bsigroup.com