

Ultrasonics — Flow measurement systems — Flow test object

The European Standard EN 61685:2001 has the status of a
British Standard

ICS 17.120.01; 17.140

National foreword

This British Standard is the official English language version of EN 61685:2001. It is identical with IEC 61685:2001

The UK participation in its preparation was entrusted to Technical Committee EPL/87, Ultrasonics, which has the responsibility to:

- aid enquirers to understand the text;
- present to the responsible international/European committee any enquiries on the interpretation, or proposals for change, and keep the UK interests informed;
- monitor related international and European developments and promulgate them in the UK.

A list of organizations represented on this committee can be obtained on request to its secretary.

From 1 January 1997, all IEC publications have the number 60000 added to the old number. For instance, IEC 27-1 has been renumbered as IEC 60027-1. For a period of time during the change over from one numbering system to the other, publications may contain identifiers from both systems.

Cross-references

The British Standards which implement international or European publications referred to in this document may be found in the BSI Standards Catalogue under the section entitled "International Standards Correspondence Index", or by using the "Find" facility of the BSI Standards Electronic Catalogue.

A British Standard does not purport to include all the necessary provisions of a contract. Users of British Standards are responsible for their correct application.

Compliance with a British Standard does not of itself confer immunity from legal obligations.

This British Standard, having been prepared under the direction of the Electrotechnical Sector Policy and Strategy Committee, was published under the authority of the Standards Policy and Strategy Committee on 14 February 2002

Summary of pages

This document comprises a front cover, an inside front cover, the EN title page, pages 2 to 38, an inside back cover and a back cover.

The BSI copyright date displayed in this document indicates when the document was last issued.

Amendments issued since publication

Amd. No.	Date	Comments

© BSI 14 February 2002

EUROPEAN STANDARD

EN 61685

NORME EUROPÉENNE

EUROPÄISCHE NORM

October 2001

ICS 17.140.50

English version

**Ultrasonics -
Flow measurement systems -
Flow test object
(IEC 61685:2001)**

Ultrasons -
Systèmes de mesure de débit -
Montage pour essai de débit
(CEI 61685:2001)

Ultraschall -
Durchflussmesssysteme -
Durchfluss-Doppler-Prüfobjekt
(IEC 61685:2001)

This European Standard was approved by CENELEC on 2001-09-01. CENELEC members are bound to comply with the CEN/CENELEC Internal Regulations which stipulate the conditions for giving this European Standard the status of a national standard without any alteration.

Up-to-date lists and bibliographical references concerning such national standards may be obtained on application to the Central Secretariat or to any CENELEC member.

This European Standard exists in three official versions (English, French, German). A version in any other language made by translation under the responsibility of a CENELEC member into its own language and notified to the Central Secretariat has the same status as the official versions.

CENELEC members are the national electrotechnical committees of Austria, Belgium, Czech Republic, Denmark, Finland, France, Germany, Greece, Iceland, Ireland, Italy, Luxembourg, Malta, Netherlands, Norway, Portugal, Spain, Sweden, Switzerland and United Kingdom.

CENELEC

European Committee for Electrotechnical Standardization
Comité Européen de Normalisation Electrotechnique
Europäisches Komitee für Elektrotechnische Normung

Central Secretariat: rue de Stassart 35, B - 1050 Brussels

Foreword

The text of document 87/202/FDIS, future edition 1 of IEC 61685, prepared by IEC TC 87, Ultrasonics, was submitted to the IEC-CENELEC parallel vote and was approved by CENELEC as EN 61685 on 2001-09-01.

The following dates were fixed:

- latest date by which the EN has to be implemented
at national level by publication of an identical
national standard or by endorsement (dop) 2002-06-01
- latest date by which the national standards conflicting
with the EN have to be withdrawn (dow) 2004-09-01

Annexes designated "normative" are part of the body of the standard.

Annexes designated "informative" are given for information only.

In this standard, annexes B and ZA are normative and annexes A, C, D, E and F are informative.

Annex ZA has been added by CENELEC.

Endorsement notice

The text of the International Standard IEC 61685:2001 was approved by CENELEC as a European Standard without any modification.

CONTENTS

INTRODUCTION	5
1 Scope	6
2 Normative references	6
3 Definitions	6
4 List of symbols	12
5 General outline of flow Doppler test object	13
6 Specification of the flow Doppler test object	13
6.1 General	13
6.2 Blood-mimicking fluid (BMF)	14
6.3 Tube	15
6.4 Tissue-mimicking material (TMM)	16
6.5 Geometry	16
7 Precautions to prevent changes in the composition of the blood-mimicking fluid (BMF)	16
8 Specifications for labelling	17
Annex A (informative) Rationale concerning the position of this standard	18
Annex B (normative) Formulae relating various quantities	21
Annex C (informative) Rationale for the numerical values chosen in this standard	22
Annex D (informative) Description of an example flow Doppler test object	24
Annex E (informative) Schematic diagram of a possible flow circuit	33
Annex F (informative) Measuring methods	34
Annex ZA (normative) Normative references to international publications with their corresponding European publicatins	38
Bibliography	35
Figure 1 – Three configurations for Doppler flow test objects	13
Figure D.1 – The main elements of a flow test object	25
Figure D.2 – Backscattering coefficient of BMF as a function of frequency	27
Figure D.3 – Attenuation of TMM (□) and BMF (○) as a function of frequency	27
Figure D.4 – Attenuation of ultrasound by material of tube wall, as a function of frequency	28
Figure D.5 – Deformation of velocity spectrum of parabolic flow by attenuation due to tube wall (wall thickness 1,5 mm)	29
Figure D.6 – Backscattering coefficient of two samples of TMM as a function of frequency	30
Figure D.7 – The quotient of attenuation by TMM (1-way passage) and frequency as a function of frequency	30
Figure D.8 – Testing for penetration depth	32
Figure E.1 – Schematic diagram of a possible flow circuit, showing the place of the flow Doppler test object	33

Table 1 – Typical ranges of parameters for blood at 37 °C, where f is the acoustic-working frequency in hertz	14
Table 2 – Specification of blood-mimicking fluid (BMF)	14
Table 3 – Parameters of tissue-mimicking material (TMM)	16
Table A.1 – Parameters concerning CW Doppler	19
Table A.2 – Additional parameters concerning pulsed Doppler and colour flow	20

INTRODUCTION

The purpose of this International Standard is to establish a **flow Doppler test object** for the acceptance testing, quality assurance testing and clinical calibration of Doppler systems, working at a frequency between 2 MHz and 10 MHz. As the response of Doppler systems depends on the signal level and on the spectral contents of the signal, it is desirable to test some aspects of a Doppler system with a test object that mimics the *in vivo* situation. A **flow Doppler test object** is particularly useful for

- testing the influence of the size and the depth of the blood vessel on the signal recorded by a Doppler system;
- testing the response of a Doppler system with a spectrum of blood velocities typical of the *in vivo* situation.

This **flow test object** is not intended as a phantom mimicking clinical conditions.

The basis of this International Standard is given by IEC Technical Report 61206:1993 *Ultrasonics – Continuous Wave Doppler systems – Test procedures*. In annex A the position of this standard in relation to IEC 61206 and IEC 61895 is described. This standard only declares parameters that can be measured with the test object. Measurement methods are given in IEC 61206 and IEC 61895.

This International Standard deals only with the **flow Doppler test object** in a restricted sense, i.e. the section in which the ultrasonic measurements are performed. Where the whole of the set-up is meant, the phrase 'flow rig' is used. The prescriptions of this International Standard define the ultrasonic properties and the flow pattern in the measurement section of the flow test object. For other aspects of the flow rig (i.e. generating and measuring flows) standard engineering practice has to be followed.

The flow conditions are simplified as much as possible: a steady flow through a straight **tube** with a circular cross-section. Generalisation of the flow conditions to other geometries and time dependent flows is required in order to test some instrument functions. This generalisation is not undertaken in this International Standard.

In annex D, an example **flow Doppler test object** is described which complies with the requirements of this International Standard. Compliance with this International Standard can also be fulfilled by measuring the properties of the materials to be used, and complying with the values given in this International Standard.

In literature [1], [2] the nomenclature about the primary measurand of Doppler systems is confused. 'Doppler frequency' and 'velocity' occur on equal footing. In 'velocity' often a correction for **Doppler angle** has been included. To avoid this ambiguity, in this International Standard the term 'Doppler frequency' is preferred. In case a Doppler system is declared to measure velocity, it is intended that measured values are converted to Doppler frequency, using **acoustic working frequency** and, if applicable, **Doppler angle**.

ULTRASONICS – FLOW MEASUREMENT SYSTEMS – FLOW TEST OBJECT

1 Scope

This International Standard specifies parameters for a **flow Doppler test object** representing a blood vessel of known diameter at a certain depth in human tissue, carrying a steady flow.

This International Standard establishes a **flow Doppler test object** which can be used to assess various aspects of the performance of Doppler diagnostic equipment.

2 Normative references

The following normative documents contain provisions which, through reference in this text, constitute provisions of this International Standard. For dated references, subsequent amendments to, or revisions of, any of these publications do not apply. However, parties to agreements based on this International Standard are encouraged to investigate the possibility of applying the most recent editions of the normative documents indicated below. For undated references, the latest edition of the normative document referred to applies. Members of IEC and ISO maintain registers of currently valid International Standards.

IEC 61206:1993, *Ultrasonics – Continuous-wave Doppler systems – Test procedures*

IEC 61102:1991, *Measurement and characterisation of ultrasonic fields using hydrophones in the frequency range 0,5 MHz to 15 MHz*

IEC 61895:1999, *Ultrasonics – Pulsed Doppler diagnostic systems – Test procedures to determine performance*

3 Definitions

For the purposes of this International Standard, the following definitions apply:

3.1

–3 dB Doppler frequency

frequency at which the power per unit frequency in the Doppler spectrum is half (–3 dB) of the maximum value

3.2

–3 dB sample volume

volume of a region in space for which the Doppler system gives a response to a point Doppler target that is above –3 dB from the maximal response, taking account of the effects of both transmission and reception

Unit: cubic millimetre, mm³

3.3

–3 dB sample volume length

largest dimension of the **–3 dB sample volume** in the direction of the beam alignment axis (see 3.5 of IEC 61102)

Unit: millimetre, mm

3.4

-3 dB sample volume width

largest value of the dimension of the **-3 dB sample volume** along an axis which is perpendicular to the beam alignment axis. In case the Doppler system has a scan plane, the axes are taken in the scan plane and perpendicular to the scan plane

Unit: millimetre, mm

3.5

acoustic-working frequency

frequency of an acoustic signal based on the output observed by a hydrophone placed in an acoustic field: it is the arithmetic mean of the two frequencies at which the amplitude of the acoustic pressure spectrum is 3 dB below the peak amplitude

[conforms to 3.4.2 of IEC 61102]

Unit: hertz, Hz

3.6

aliasing

false indication of signal frequency as a result of sampling at too low a frequency

NOTE The threshold for **aliasing** depends on pulse repetition frequency and a possible base line shift.

3.7

average frequency of the Doppler spectrum

parameter estimated by clinical Doppler systems for the short-time average in a Doppler spectrum, ignoring the contributions from noise

NOTE The **average frequency of the Doppler spectrum** is generally determined for a small time interval, typically 2 ms to 20 ms).

Unit: hertz, Hz

3.8

axial response range

depth range in tissue over which a signal from a specific target plus noise is at least 3 dB above the noise level

[see 2.4.1 of IEC 61206]

Unit: millimetre, mm

3.9

blood-mimicking fluid (BMF)

fluid which simulates blood acoustically and is moved at a known flow rate through the **flow Doppler test object**

3.10

channel separation

ratio of the signal level in the signal channel corresponding to the movement in the test object (the desired output voltage) and the signal level in the opposite channel (the undesired output voltage)

NOTE **Channel separation** is to be quoted in decibels as twenty times the logarithm of the desired output to the undesired output voltage.

[see 2.6.1 of IEC 61206]

Unit: decibel, dB

3.11**colour display spatial resolution**

minimum separation in space for which two separate moving point targets or line targets can be resolved

NOTE The **colour display spatial resolution** is measured in three directions: 1) along the beam alignment axis, 2) the direction perpendicular to the scan plane and 3) the direction in the scan plane perpendicular to the beam alignment axis.

Unit: millimetre, mm

3.12**dead zone boundary**

boundary of the region close to the transducer in which the system is insensitive to movement

3.13**depth of measurement**

distance from the surface of the **tissue-mimicking material** to the centre of the **tube**. In case various attenuating materials, not being **tissue-mimicking material** or **blood-mimicking material**, are present in the ultrasonic path, the **depth of measurement** is taken to be the equivalent distance in the **tissue-mimicking material**, from the surface of the **tissue-mimicking material** to the centre of the **tube**, over which the attenuation is the same as that in the actual path in the **flow Doppler test object**

(see also annex B)

Symbol: *M*

Unit: millimetre, mm

3.14**Doppler angle**

acute angle between the Doppler beam axis used for the Doppler measurement and the axis of the **tube**

Symbol: θ

Unit: degree, °

3.15**Doppler angle error**

difference between the measurement of the **Doppler angle** and its true value

Unit: degree, °

3.16**Doppler frequency –3 dB response range**

frequency region in the Doppler spectrum around the frequency where power per unit frequency is maximal, which is delimited by the nearest **–3 dB Doppler frequencies**

Unit: hertz, Hz

NOTE The Doppler frequency response range at another signal level may be used in an analogous way.

3.17**Doppler frequency non-linearity error**

largest frequency deviation of a data point from the least squares fitted line through the origin in a plot of Doppler frequency versus observed velocity over the **Doppler frequency –3 dB response range**

[see 2.3.2 of IEC 61206]

Unit: hertz, Hz

3.18**Doppler frequency response**

Doppler signal level (in dB) as a function of Doppler frequency

3.19**dynamic range**

ratio (in decibels) between the largest Doppler signal which can be processed by the system without generating spurious outputs and the smallest Doppler signal which can be detected

NOTE **Dynamic range** is a measure of the ratio between the maximum allowable signal from clutter and the minimum signal level at which flow can be detected.

Unit: decibel, dB

3.20**fixed target effect on sensitivity**

change in Doppler output level (in decibels) when a strongly reflecting stationary structure (a perfect reflector, see 2.3.3.2 of IEC 61206) is brought into the Doppler beam

Unit: decibel, dB

3.21**flow Doppler test object**

physical model of blood flowing within a vessel that is embedded in soft tissue. The object is composed of **tissue-mimicking material** through which **blood-mimicking material** is caused to flow

3.22**frequency to colour translation table**

table which describes the way in which Doppler frequencies are mapped to colours for display

3.23**highest detectable Doppler frequency**

Doppler frequency corresponding to the highest **observed velocity** which can be determined unambiguously (without **aliasing**)

Unit: hertz, Hz

3.24**inner diameter**

inner diameter of the **tube** through which the **blood-mimicking fluid** flows

Symbol: *D*

Unit: millimetre, mm

3.25**inlet length**

distance over which the **tube** must have a uniform cross-section in order to ensure that a well defined velocity distribution develops which is independent of the flow conditions at the entry of the **tube**

Symbol: *L*

Unit: millimetre, mm

3.26

intrinsic spectral broadening

width of the frequency region over which the spectral intensity is above -3 dB from its maximal value, when the Doppler system observes a moving target having a single velocity

Unit: hertz, Hz

3.27

lowest detectable Doppler frequency

Doppler frequency corresponding to the lowest **observed velocity** which can be distinguished from noise

Unit: hertz, Hz

3.28

maximum frequency of the Doppler spectrum

parameter estimated by a Doppler system for the highest occurring frequency in a Doppler spectrum, ignoring the contributions from noise

NOTE 1 The **maximum frequency of the Doppler spectrum** corresponds to the highest velocity occurring in the sample volume at a certain time.

NOTE 2 Clinical Doppler systems generally determine the **maximum frequency of the Doppler spectrum** for a small time interval (typically 2 ms to 20 ms).

Unit: hertz, Hz

3.29

observed velocity

component of the velocity of a scatterer that is directed towards or away from the transducers

[definition 1.3.10 of IEC 61206]

3.30

parabolic velocity profile

axisymmetrical flow distribution in a cross-section of the **tube**, in which the velocity decreases in proportion to the square of the distance from the **tube's** axis, and the velocity at the **tube** wall is zero

3.31

penetration depth

maximum depth in **tissue-mimicking material** from which a Doppler signal can be detected from noise

Unit: millimetre, mm

3.32

sample volume position error

difference between the centre of the sample volume on the image and its true position

Unit: millimetre, mm

3.33

tissue-mimicking material (TMM)

material whose pertinent ultrasonic properties (sound velocity, attenuation and scattering) are similar to those of soft tissue

3.34**tube**

conduit which carries the **blood-mimicking fluid (BMF)** flow

NOTE The word **tube** also applies to the case of a hole in the **tissue-mimicking material**.

3.35**volume flow measurement error**

100 times the absolute value of the difference between the Doppler measurement of a particular volume flow rate and its true value, divided by the true value

NOTE The **volume flow measurement error** has a sign and is reported as a percentage.

3.36**wall thickness**

thickness of the wall of the **tube**

NOTE In the case of a hole in the **tissue-mimicking material**, the value of the wall thickness is zero.

Symbol: w

Unit: millimetre, mm

3.37**working distance**

distance between the transducer and a specific target in **tissue-mimicking material** when the signal is maximal

Unit: millimetre, mm

3.38**zero-velocity noise level**

r.m.s. voltage of the signal (in dB) on the Doppler output connector under the condition that the moving portion of the Doppler test object is stopped

Unit: decibel, dB

NOTE 1 Generally the **zero-velocity noise level** is the sum of the system noise level and the clutter noise level.

NOTE 2 **Zero-velocity noise level** is reported as dB with respect to 1 mV r.m.s.

4 List of symbols

c = velocity of sound

c_w = velocity of sound in the **wall material**

c_t = velocity of sound in the **tissue-mimicking material**

c_b = velocity of sound in the **blood-mimicking fluid**

D = **inner diameter of tube**

f = **acoustic-working frequency** of the investigated equipment

h = path length in **TMM**

L = **inlet length**

M = **depth of measurement** *

q = flow rate of **blood-mimicking fluid**

Re = Reynolds number *

v = local velocity of **blood-mimicking fluid**

v_{avg} = velocity averaged over the cross-section of the **tube** *

v_{max} = the highest velocity occurring in a cross-section of the **tube** *

w = **wall thickness of tube**

Z = characteristic acoustic impedance *

α = attenuation coefficient of sound

η = viscosity of a **blood-mimicking fluid**

θ = **Doppler angle**

ρ = density of material

σ = differential scattering cross-section in the backward direction per unit volume, also called backscatter coefficient

NOTE For quantities marked with an asterisk, formulae are given in annex B.

5 General outline of flow Doppler test object

An example showing the place of the **flow Doppler test object** in a complete measurement system (flow rig) is shown in annex E.

The **flow Doppler test object** consists of a block of material which mimics the ultrasonic properties (sound velocity, attenuation and scattering) of soft tissue. In a straight cylindrical conduit flow a **blood-mimicking fluid (BMF)** represents flowing blood. The arrangement of **tissue-mimicking material (TMM)** and conduit is such that the Doppler transducer can observe the **BMF** flow through a range of depths in tissue. Three different forms of a **flow Doppler test object** exist:

- the conduit is made of a **tube** above which a triangular block of **TMM** is present (figure 1a);
- the conduit is made of a **tube** lying inside the **TMM** (figure 1b);
- the conduit is a cylindrical hole inside the **TMM** (figure 1c).

Hereinafter, the term **tube** shall be used to refer to all types of conduit.

A **flow Doppler test object** may have a number of conduits with different diameters. In that case, the requirements of this International Standard apply to each conduit separately.

The **blood-mimicking fluid (BMF)** has rheological properties resembling those of whole blood in large arteries (of diameter $>0,5$ mm). Under such circumstances, the effect of non-Newtonian flow can be neglected. The backscatter coefficient of the **BMF** is similar to that of blood *in vivo*. For this purpose some solid particles are added to the fluid.

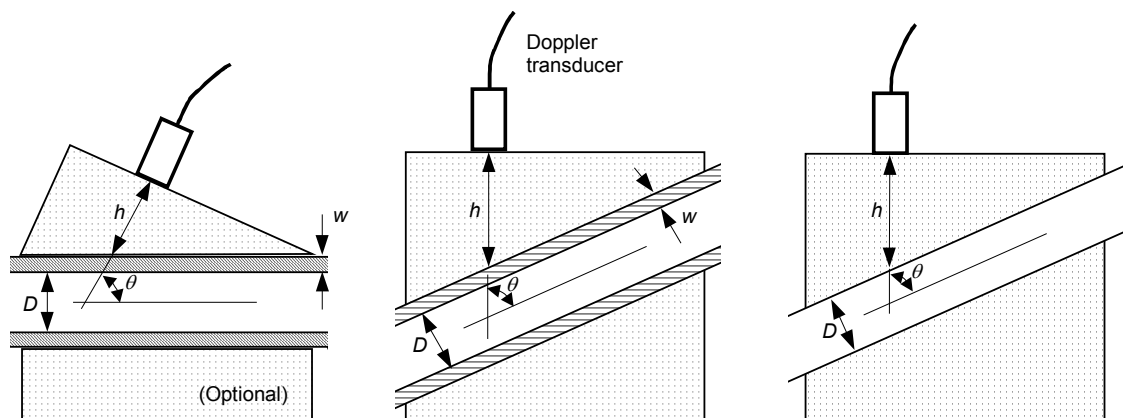

IEC 1068/01

Figure 1a)

Figure 1b)

Figure 1c)

Figure 1 – Three configurations for Doppler flow test objects

6 Specification of the flow Doppler test object

6.1 General

Examples of suitable measuring methods can be found in annex F.

Unless otherwise indicated, the specified values shall be valid at 22 °C. The **flow Doppler test object** is intended for use in the temperature range 19 °C to 25 °C.

The **flow Doppler test object** is intended for use with a steady (non-pulsatile) flow. The maximum instantaneous deviation of the flow rate from its average value shall be measured and reported for any particular application.

The velocity of the **BMF** averaged over the cross-section of the **tube** shall be known with an uncertainty not larger than 5 % (95 % level of confidence).

6.2 Blood-mimicking fluid (BMF)

The properties of the **blood-mimicking fluid (BMF)** shall be similar to blood *in vivo*.

The concentration of particles shall be sufficiently high that at least 1 000 particles are present in the smallest sample volume of the Doppler system at a given instant in time.

The rheological properties of the **BMF**, when flowing in **tubes** with a diameter of at least 0,5 mm, shall be those of a Newtonian fluid.

Table 1 – Typical ranges of parameters for blood at 37 °C, where f is the acoustic-working frequency in hertz

Sound velocity	(1 570 to 1 595) m s ⁻¹ [3][4]
Density	(1 050 to 1 055) kg m ⁻³ [5]
Characteristic acoustic impedance	(1,65 to 1,68) × 10 ⁶ kg m ⁻² s ⁻¹
Backscatter coefficient	4,0 × 10 ⁻³¹ × f^4 m ⁻¹ Hz ⁻⁴ sr ⁻¹ [6]
Attenuation	(0,15 to 0,22) × 10 ⁻⁴ × f dB m ⁻¹ Hz ⁻¹ [3][4]
Viscosity	(1,7 to 4,4) × 10 ⁻³ Pa s [5]

Derived from table 1, the following parameters for the **BMF** are chosen:

Table 2 – Specification of blood-mimicking fluid (BMF)

Sound velocity	(1 570 ± 30) m s ⁻¹
Density	(1 050 ± 40) kg m ⁻³
Characteristic acoustic impedance	Follows from sound velocity and density
Backscatter coefficient	(1 to 10) × 10 ⁻³¹ × f^4 m ⁻¹ Hz ⁻⁴ sr ⁻¹
Attenuation	<0,1 × 10 ⁻⁴ × f dB m ⁻¹ Hz ⁻¹
Viscosity	(4 ± 0,4) × 10 ⁻³ Pa s

As an alternative to measuring the absolute value of backscatter coefficient, it is allowed to make a relative measurement to flowing human blood of the following composition: plasma replaced with 0,9 % saline, haematocrit within the normal range 40 %-48 %.

See clause C.2 for the rationale of the chosen values.

The backscatter coefficient shall be known with an uncertainty not greater than a factor of 2,0 (3 dB).

6.3 Tube

6.3.1 Inner diameter

The **inner diameter** of each **tube** shall have one of the following diameters: 0,5; 1,0; 2,0; 4,0; 8; 16; 32 mm. The diameter shall be realised with a deviation of less than $\pm 10\%$ from the nominal value.

For calculation of **BMF** velocity from **BMF** flow (see annex B), the actual cross-section of the **tube** shall be used. Uncertainty in the **tube** cross-section shall be taken into account in the calculation of the uncertainty of the velocity. For thin-walled elastic tubes, it may be necessary to use a pressure-dependent value of the cross-sectional area.

6.3.2 Inlet length

In order to ascertain well-known flow conditions at the measuring point, the **tube** shall be straight and of uniform inner diameter D . Upstream of the measuring point, the inner area of the **tube** shall be uniform over an **inlet length** L . The **inlet length**, as well the outlet length, should not include any connector that disturbs the flow by changes in cross-sectional shape or area. In case the flow profile at the beginning of the inlet length is flat, L is for laminar flow ($Re < 2\ 000$) given by

$$L = 0,03 D Re.$$

Using this condition, the axial flow velocity in the **tube** deviates less than 5 % from the value calculated from a **parabolic velocity profile** [7].

NOTE The above statement is true for pure fluids; the applicability to suspensions of particles is still under study.

For turbulent flow ($Re > 4\ 000$) L shall be larger than $40 D$.

In the region $2\ 000 < Re < 4\ 000$ the flow pattern depends on details of the experimental set-up, and cannot be used without external calibration [8].

Alternative methods to reach a **parabolic velocity profile** may be used, provided these methods are validated.

6.3.3 Wall

The **tube** wall can distort the ultrasound by reflection, refraction and attenuation [9]. The longitudinal velocity of sound of the wall material of a **tube** should be chosen as close as possible to that of the **TMM** to avoid total reflection at small Doppler angles [10], [11], [12]. For a hole in the **TMM** (zero **wall thickness**), the boundary between **BMF** and **TMM** may act as a lens and a reflector. These effects depend on the **Doppler angle**.

In the following, the effects of a two-way passage of the ultrasound through the **tube** wall are considered.

The distortion shall be such that the **tube** wall reduces the signal level by an amount which is less than the reduction in signal level caused by a layer of **TMM** having a thickness equal to the vessel **inner diameter**.

For a **parabolic velocity profile** in the **tube**, which is uniformly insonicated, the spectral distortion shall be such that the intensity of the signal from blood flowing at velocities near zero

shall not be reduced more than 3 dB compared to the intensity of the signal of blood flowing at the highest velocity. Allowance should be made for the frequency response of the instrument measuring the spectral distortion.

6.4 Tissue-mimicking material (TMM)

The **TMM** should have values for acoustical quantities as specified in table 3 (see also clause C.6).

Table 3 – Parameters of tissue-mimicking material (TMM)

Sound velocity	$(1\,540 \pm 15) \text{ m s}^{-1}$
Attenuation (one-way passage)	$(0,5 \pm 0,05) \times 10^{-4} \times f \text{ dB m}^{-1} \text{ Hz}^{-1}$
Attenuation alternative (see clause C.6)	$(0,75 \pm 0,05) \times 10^{-4} \times f \text{ dB m}^{-1} \text{ Hz}^{-1}$
Characteristic acoustic impedance	$(1,60 \pm 0,16) \times 10^6 \text{ kg m}^{-2} \text{ s}^{-1}$
Backscatter coefficient	$(1 \text{ to } 4) \times 10^{-28} \times f^4 \text{ m}^{-1} \text{ Hz}^{-4} \text{ sr}^{-1}$

6.5 Geometry

In the **flow Doppler test object**, the angle between the surface, at which the transducer is applied, and the vessel shall be 0° , 30° , 45° or 60° .

It is recommended that mechanical means be provided to hold a transducer such that the **Doppler angle** can be reproduced with an uncertainty of less than 1° (95% confidence).

It is recommended that the **flow Doppler test object** be made such that the minimal **depth of measurement** which can be obtained is less than two **tube** diameters. However, this depends also on the construction (width) of the Doppler probe.

It is also recommended that a signal attenuation (one way) by the **TMM** of at least 25 dB can be obtained. This means that the **flow Doppler test object** shall provide a maximum **depth of measurement** in metres, at a frequency f in hertz, greater than

$$(500 \times 10^3 \text{ m Hz}) \times f^{-1}$$

or

$$(330 \times 10^3 \text{ m Hz}) \times f^{-1}$$

depending on which value of the attenuation of the **TMM** is chosen from table 3.

7 Precautions to prevent changes in the composition of the blood-mimicking fluid (BMF)

It is essential that the backscatter coefficient of the **BMF** does not change. The following precautions shall be taken to ensure that the backscatter coefficient is constant.

- 1) The flow circuit shall be made in such a way that no depositions of the scattering material are present during use. This task is facilitated by using particles which are small and have a density close to that of the **BMF**. Depending on the kind of particles, it is necessary to provide sufficient mixing of the **BMF** by circulation or stirring. A time switch on the pump, causing it to operate for 15 min at regular intervals (ranging from 2 h to 14 days), may be used to avoid particle settling and clumping when the test object is not being used. For some systems, vigorous pumping before use may be sufficient.

NOTE These precautions are required because changes in the backscatter coefficient may result from separation of the scattering particles from the **BMF**, scatterer attrition or clustering of particles.

- 2) Introduction of foreign solid particles shall be minimised. A closed circuit is recommended.
- 3) The **BMF** shall be free from gas bubbles. This may be achieved by:
 - degassing of the fluid by boiling or exposing to a low pressure before use;
 - avoidance of splashing;
 - mounting a filter with small pores (25 μm – 40 μm) upstream of the test section;
 - inclusion of a bubble trap;
 - avoidance of cavitation resulting from a combination of high flow rates and rapid changes of diameter in the flow circuit;
 - keeping the fluid everywhere in the circuit under positive pressure with respect to the atmosphere, or making connections air-tight.
- 4) The fulfilment of conditions specified in 1), 2) and 3) shall be specified by the manufacturer. The degree of fulfilment can be monitored by measuring the signal level from a Doppler system monitoring the flow in the **tube**.

NOTE Short duration deviations more than 3 dB above the mean value point to significant disturbing isolated particles. Large numbers of disturbing particles are difficult to detect: they give a generally increased signal level. If the disturbing particles separate physically from the main fluid (such as gas bubbles sticking to the wall), their presence can often be detected by changes in signal level some time after a change from a very low to a high flow-rate.

8 Specifications for labelling

The manufacturer of a **flow Doppler test object** shall specify values, if possible with upper and lower limits, on the following:

- life of the **TMM**, under specified conditions of use;

NOTE Destruction of **TMM** by using an incompatible **BMF** has been reported; a water-based fluid will dissolve gel-based materials.
- sound velocity, attenuation, characteristic acoustic impedance and backscatter coefficient of the **TMM**;
- **inner diameter of tube**;
- **tube wall density, sound velocity and attenuation**;
- **wall thickness of tube**;
- fractional change in **tube inner diameter** with transmural pressure;
- surface/vessel angle;
- life of the **BMF**, under specified conditions of use;
- measures to avoid gas bubbles;
- scatterer material in the **BMF**, size and number density;
- sound velocity, density, backscatter coefficient and the method by which it was determined, attenuation and viscosity of the **BMF**;
- permitted temperature range for storage and for use with required accuracy.

Values for attenuations and backscatter coefficients shall be specified as a function of the frequency over the frequency range for which the **flow Doppler test object** is intended.

Annex A (informative)

Rationale concerning the position of this standard

The basis of this International Standard is given by IEC Technical Report 61206:1993. Clause 2 of IEC 61206 gives a general description for overall tests of complete continuous wave Doppler systems, specified for several parameters such as frequency response and spatial response. Clause 3 describes six different Doppler test objects with test procedures to measure these parameters.

These test objects are:

- string Doppler test object;
- band Doppler test object;
- disk Doppler test object;
- piston Doppler test object;
- small ball test object;
- **flow Doppler test object.**

Besides these, electronic or acoustic injection techniques can be used.

This International Standard gives specifications and a description for one of these test objects, the **flow Doppler test object**. However, whereas IEC 61206 is restricted to the testing of continuous wave Doppler systems, this standard is also applicable to the testing of pulsed Doppler and colour flow imaging systems. Table A.1 gives an overview of the parameters specified in clause 2 of IEC 61206. Table A.2 gives a similar overview of additional parameters relating to pulsed Doppler systems. IEC technical reports for these systems have been published (IEC 61895) or are under development¹. The second column of both tables lists the suitability of a **flow Doppler test object** containing one **tube** to measure these parameters, and is considered the best that can be achieved using **flow Doppler test objects**. For some parameters wide **tubes**, and for other parameters small **tubes**, are required. No judgement is given on the usefulness of other Doppler test objects.

¹ *Ultrasonics – Colour flow mapping systems – Test procedures to determine performance* (under consideration).

Table A.1 – Parameters concerning CW Doppler

Parameter	Suitability of a flow Doppler test object	Reference to subclause of IEC 61206
Working distance	good	2.2.3
Zero-velocity noise level	good	2.2.4
Doppler frequency response		2.3
Doppler frequency –3 dB response range	fails ^a	2.3.1
Doppler frequency non-linearity error	moderate ^b	2.3.2
Large-signal performance		2.3.3
Dynamic range	moderate	2.3.3.1
Fixed target effect on sensitivity	moderate ^c	2.3.3.2
Intermodulation distortion (Particular test of dynamic range)	fails ^d	2.3.3.3
Spatial response		2.4
Axial response range	good	2.4.1
–3 dB sample volume width	moderate ^e	2.4.2
Acoustic-working frequency	not applicable	2.5
Flow direction separation		2.6
Channel separation	good	2.6.1
Simultaneous flow test	fails ^f	2.6.2
Response to Doppler spectrum		2.7
Volume flow measurement error	good	2.7.1
Maximum frequency of the Doppler spectrum	good	2.7.2
Penetration depth	moderate ^g	–
<p>^a This test requires a test object giving a narrow band Doppler signal of variable centre frequency or a known broad spectrum signal covering the whole frequency range of the instrument.</p> <p>^b For this test a test object with a single velocity is preferred.</p> <p>^c Depends on construction of test object.</p> <p>^d This test requires two narrow band Doppler signals.</p> <p>^e Depends on tube diameter.</p> <p>^f This test requires two targets.</p> <p>^g This test requires stability and reproducibility of those test object parameters which determine the Doppler signal level. These are primarily TMM attenuation, tube wall attenuation, and the backscatter coefficient of the BMF. At present it is not known if a reasonable stability of BMF backscatter coefficient is achievable.</p>		

Table A.2 – Additional parameters concerning pulsed Doppler and colour flow

Parameter	Suitability of a flow Doppler test object
Pulsed Doppler	
Highest detectable Doppler frequency	moderate ^a
Average frequency of the Doppler spectrum	good ^b
Maximum frequency of the Doppler spectrum	good
Doppler angle error	good
–3 dB sample volume length	moderate
–3 dB sample volume width	moderate ^c
Sample volume position error	moderate ^c
–3 dB sample volume	fails
Dead zone boundary	good
Intrinsic spectral broadening	moderate ^a
Colour flow mapping	
Frequency to colour translation table	good
Colour display spatial resolution	moderate ^a
Highest detectable Doppler frequency	moderate ^a
Lowest detectable Doppler frequency	moderate ^a
^a For this test a test object with a single velocity is preferred. ^b Depends on wall thickness . ^c Depends on tube diameter.	

Annex B
(normative)

Formulae relating various quantities

Reynolds number is given for a flow rate of **blood-mimicking fluid (BMF)**, q , in a **tube** of diameter, D , by

$$Re = 4 q \rho / (\pi D \eta)$$

where

η is the dynamic viscosity of the **BMF**;

ρ is the density of the **BMF**.

The velocity averaged over a cross-section of the **tube** is:

$$v_{avg} = 4 q / (\pi D^2).$$

In case of a **parabolic velocity profile** the axial velocity is:

$$v_{max} = 2 v_{avg}$$

and

$$v_{max} = 8 q / (\pi D^2).$$

The characteristic acoustic impedance, Z , in a specified medium is given by:

$$Z = \rho c$$

where

ρ is the density of the medium;

c is the velocity of sound in the medium.

The **depth of measurement**, M , is given by:

$$M = h + (w \alpha_w / \alpha_t + D / 2) / \sin(\theta)$$

where (see figure 1)

α_w is the attenuation coefficient of the **wall** material;

α_t is the attenuation coefficient of the **TMM**;

h is the path length in the **TMM**;

D is the **inner diameter** of the **tube**;

w is the **wall thickness**;

θ is the **Doppler angle**.

NOTE 1 This formula is valid if the transit time of the ultrasound passing through the wall is very much less than that in the **TMM**.

NOTE 2 In case the **TMM** is covered by a protecting foil with thickness d and attenuation coefficient α_f a term $d \alpha_f / \alpha_t$ is added to M .

Annex C (informative)

Rationale for the numerical values chosen in this standard

NOTE This rationale provides justification for a number of choices made in this draft. The numbering in the titles of the clauses refers to the clauses of the main document.

C.1 General

In this International Standard requirements are given for parameters concerning the different parts of the **flow Doppler test object**, the **blood-mimicking fluid (BMF)**, the **tube**, the **tissue-mimicking material (TMM)** and the geometry of the **flow Doppler test object**. The chosen ranges of values are in the ranges which occur *in vivo*. In these choices two opposite interests have been considered:

- the range has to be as wide as possible to make it easy to implement a **flow Doppler test object**;
- the range has to be so narrow that tests on various **flow Doppler test objects** will give essentially the same outcome. As the results of Doppler measurements are generally of a qualitative nature, the error margin is set to ± 5 % for velocities and to ± 3 dB for signal levels.

The frequency range is limited from 2 MHz to 10 MHz. The lower limit is natural, as there exist no diagnostic instruments working with a lower frequency. Diagnostic Doppler systems using frequencies higher than 10 MHz are coming into use. Here the limitation is set by a lack of knowledge about the properties of materials which could be used to construct a **flow Doppler test object**.

The requirements for the **flow Doppler test object** cannot be separated completely from the properties (particularly the ultrasonic frequency) of the Doppler system tested. At this moment it is not known whether it is possible to make a single **flow Doppler test object** which fulfils the requirements for all frequencies. Upon change of the ultrasonic frequency it may therefore be necessary to change the composition of the **flow Doppler test object**.

C.2 Clause 6.1: Blood-mimicking fluid (BMF)

The values given in table 1 represent blood at 37 °C.

The ultrasonic scattering of blood *in vivo* may vary considerably according to its composition and flow conditions [13]. It was considered not realistic to specify a range. The values given in table 1 are therefore somewhat arbitrary. The chosen values [6] are for a well stirred suspension of human erythrocytes at a haematocrit of 40 %. Herein, the effect of red cell aggregation which may increase the scattering coefficient is absent. It is believed that these values are in the range of values occurring for arterial blood flowing in vessels larger than 0,5 mm diameter. A rather wide range of acceptable backscatter coefficient is chosen in order to facilitate the preparation of a **BMF**. The actual value should be known to within a factor of two. With this margin the backscatter coefficient contributes ± 3 dB to the uncertainty in the signal level of the reflected signal. As absolute measurement of backscattering is difficult, it is allowed to refer the backscattering of **BMF** to a blood preparation comparable to that cited in the literature [6]. (A narrower margin is desirable, but has not yet been realised.) The uncertainty in backscattering of the **BMF** influences the measurement of penetration depth. As most Doppler systems can cope with a signal attenuation of 40 dB, it follows that an uncertainty of 3 dB in the backscattering contributes an error smaller than ± 7 % to penetration depth. At present this is acceptable.

The allowable range of sound velocities of **BMF** is such that either a close representation of blood or a condition of no refraction with respect to **TMM** can be chosen.

The frequency dependence of the attenuation of blood is somewhat stronger than the value indicated in table 1 [3], [4]. For **BMF**, the attenuation should be low (table 2), in order to minimise inhomogeneity of the sound field inside the **tube**. In any case, the attenuation in **BMF** is much smaller than in the **TMM**.

The viscosity is on the high side of the values for blood *in vivo*. The higher viscosity of the **BMF** compared to blood promotes laminar flow, and therefore reproducible conditions.

The number density of particles in the **BMF** has to be chosen large enough that the discrete structure of the particles does not show up in the Doppler spectrum. The sample volume of a Doppler system can be calculated as the product of the -3 dB beam area and the effective length of the sample volume. Note that the effective length of the sample volume is limited by the ultrasound path within the **tube** when this is less than the sample volume length. The smallest sample volume which occurs presently is $0,1 \text{ mm}^3$; therefore a **BMF** for general use should contain at least 10^{13} particles per m^3 . It has been shown [14] that the statistics of Doppler spectra obtained from human blood and from a glycerine-water mixture with SephadexTM particles (estimated concentration ranging from 2×10^{11} to 10^{13} per m^3) were equal for this particular (CW) Doppler system with an estimated sample volume of 50 mm^3 .

C.3 Clause 6.3.1: Inner diameter

The range of diameters of the **tube** is limited on the lower side (0,5 mm) by the non-Newtonian nature of blood flow in smaller vessels [5]. The largest diameter (32 mm) represents the aorta. Succeeding diameters differ by a factor of two. Thus measurements on vessels of all sizes which occur in the body can be modelled with the **flow Doppler test object**. By prescribing certain preferred diameters the exchange of results obtained with different **flow Doppler test objects** is promoted.

C.4 Clause 6.3.2: Inlet length

The rules for the **inlet length** for laminar flow are well established [7]. The upper limit of the allowable Reynolds number is arbitrary. With very smooth **tubes** flow will stay laminar up to high Reynolds numbers. As the damping influence of the wall diminishes with increasing Reynolds number, small disturbances will have large effects. The development of turbulent flow is very gradual for $Re > 2\ 000$, until at $Re = 4\ 000$ the turbulent flow pattern is fully developed [8].

It is well known that flow obstacles downstream of the measuring point have much less influence on the flow profile than obstacles up-stream. Downstream obstacles which are more than two **tube** diameters away from the point of interest can be ignored.

C.5 Clause 6.3.3: Wall

A flat spectrum of Doppler velocities has been obtained with a polyethylene tubing [15], indicating that in this case spectral distortion was not significant.

C.6 Clause 6.4: Tissue-mimicking material (TMM)

A rather large amount of knowledge is available about **TMMs** [16], [17]. The attenuation and backscatter coefficient of the **TMM** are in the range of liver tissue, thereby conforming to the values in use for scanning test objects. To make it possible to build relatively compact flow test objects for low frequencies a higher attenuation ($0,75 \text{ dB cm}^{-1} \text{ MHz}^{-1}$) may be used as an alternative. The sound velocity is important, although the use of a **tissue-mimicking material** having a slightly different velocity is possible. In this case, for a sound velocity outside the range specified in table 3, one can scale the test object either to the time of flight of the ultrasound pulses, or to focusing of the sound beams, but not to both.

Annex D (informative)

Description of an example flow Doppler test object

D.1 Introduction

The following example is derived from the results of European Community project MAT-CT 940091 [12, 22-25]. For rationales, details and variations the reader is referred to these reports.

For this **flow Doppler test object**, the following are described:

- intended use;
- construction of the **flow Doppler test object**;
- properties of the **flow Doppler test object**;
- stability of the **flow Doppler test object**;
- examples of applications.

NOTE The properties of a **flow Doppler test object** depend on the materials used; brand names can be found in [22-24].

D.2 Intended use

Intended uses of this **flow Doppler test object** are: acceptance testing, quality assurance, system breakdown evaluation, education of users and system set-up preventing human exposure to sound radiation.

This **flow Doppler test object** allows performance of tests for **working distance**, range gate, relative measurements of penetration and further tests for peak velocity and angle correction software accuracy [1].

This **flow Doppler test object** offers a steady, parabolic flow pattern in a rather wide **TUBE** (diameter 8 mm), embedded in ultrasound absorbing **TMM**. The **TMM** carries on top a fluid with the same composition as the fluid components of the **TMM** (see figure D.1).

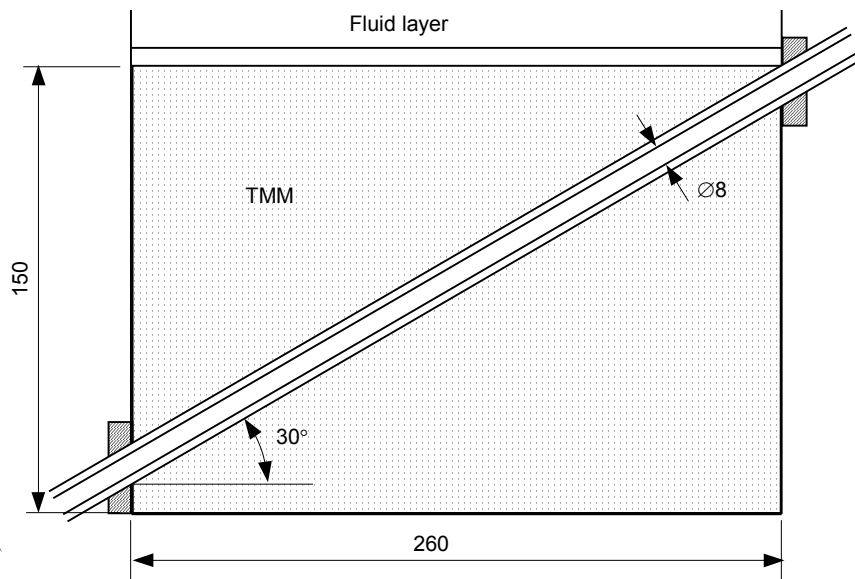

IEC 1069/01

Dimensions in millimetres

Figure D.1 – The main elements of a flow test object

The basic **flow Doppler test object** as described can be varied to satisfy specific needs. By introducing small or double vessels a large number of the tests mentioned in IEC 61206 can be executed. To keep the description concise, hereunder only the **flow Doppler test object** with a single 8 mm vessel is described. One should be aware of the fact that results for five realisations of one design of the test object are presented. Slight differences do exist. Larger differences exist between the flow rigs (flow circuit, pump, flowmeter). Data for backscattering may contain systematic differences between laboratories, and can only be used for relative comparisons.

D.3 Construction of the flow Doppler test object

D.3.1 Preparation of the tube

The flow conduit is made from C-flex tubing [12] with a circular cross-section. Nominal sizes of the **tube** are: internal diameter 8,0 mm, **wall thickness** 1,6 mm. The **tube** is glued into the tank under slight axial tension [18]. The **inlet length** (see Annex E) depends on the achievable flow rate and varies between 300 mm and 500 mm.

D.3.2 Preparation of the tissue-mimicking material (TMM)

A mixture is made from the following materials (weight % pure components):

82,96 % water;

11,21 % glycerol;

3,00 % agar;

0,94 % aluminium oxide powder 3,0 μm ;

0,88 % aluminium oxide powder 0,3 μm ;

0,53 % silicon carbide powder 400 grain;

0,46 % benzalkoniumchloride.

For more details, see [12].

The mixture is stirred and heated to 96 °C, left at that temperature for one hour and cooled down. At 42 °C it is poured into the tank containing the **tube**. After cooling down the test object, a shallow layer of coupling fluid is applied on the top of the **TMM**. This fluid is made by mixing water, glycerol and benzalkoniumchloride in the same ratio as in the **TMM**. Regularly the Doppler transducer is applied from the top. The side walls of the container are made of plastic.

D.3.3 Preparation of the blood-mimicking fluid (BMF)

A mixture is made from the following materials (weight % pure components):

- 83,86 % water;
- 10,06 % glycerol;
- 3,36 % dextran (molecular weight 100 kDa-200 kDa);
- 1,82 % Orgasol (copolyamide 6/12) particles 5 µm;
- 0,90 % synperonic N detergent surfactant.

For more details, see [12].

The materials are mixed, starting with water, surfactant and Orgasol. Gas is removed by placing under reduced pressure. The final mixture is sieved through a sieve with openings of 30 µm.

NOTE To obtain a neutrally buoyant **BMF**, small amounts of water (1 %) or glycerol (0,2 %) can be added, depending on whether the Orgasol particles float or sink respectively. This adjustment should not be made until the Orgasol particles are 48 h in the fluid. Some of the fluid diffuses into the Orgasol particles.

D.4 Properties of the flow Doppler test object

D.4.1 Blood-mimicking fluid (BMF)

The values as required in table 1 were measured at a temperature of 22 °C and are as follows, where the figures given in brackets are the temperature coefficients for the range (22 ± 5) °C:

- sound velocity: 1 548 m s⁻¹ (+5 m s⁻¹ °C⁻¹);
- density: 1 037 kg m⁻³ (-0,22 kg m⁻³ °C⁻¹);
- characteristic acoustic impedance: 1,61 × 10⁶ kg m⁻² s⁻¹;
- backscatter coefficient: see figure D.2;
- attenuation: see figure D.3;
- viscosity: 4,0 × 10⁻³ Pa s (-0,11 × 10⁻³ Pa s °C⁻¹).

All properties are found to be sufficiently stable to fulfil the requirements of table 2. An exception has to be made for the backscattering. It was found that backscattering is sensitive to clustering of the Orgasol particles. This clustering is influenced by subjecting the fluid to shear stress, either by circulating it in a flow circuit or by sieving it. The backscatter coefficient can vary as a result of these effects. The backscattering was made equal to that of flowing blood, with plasma replaced with 0,9 % saline and haematocrit in the normal range (42 % – 48 %). This is blood in which no aggregation of red cells occurs.

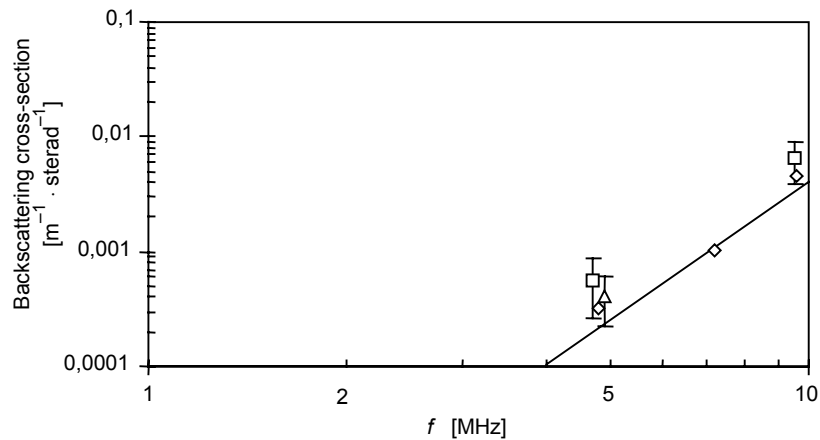

IEC 1070/01

NOTE The error bars indicate ranges of values obtained. The points without bars were obtained in one sample.

Figure D.2 – Backscattering coefficient of BMF as a function of frequency

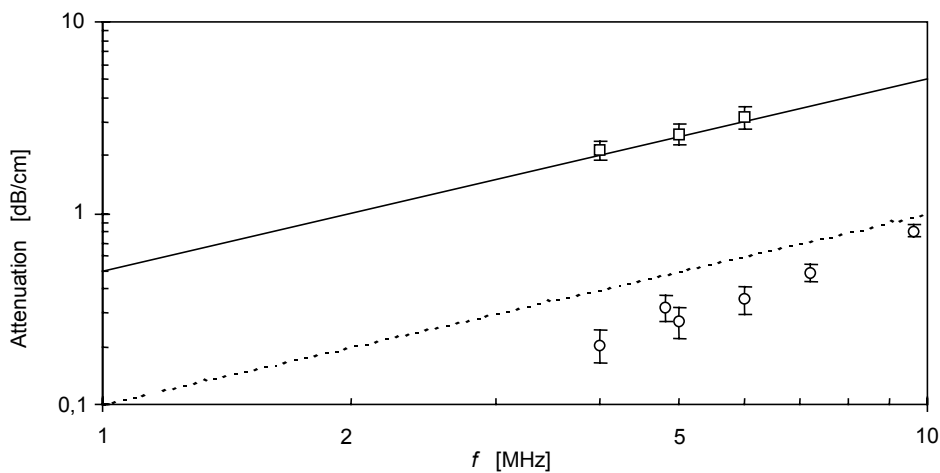

IEC 1071/01

NOTE Drawn lines represent the target value for TMM, respectively the upper limit for BMF.

Figure D.3 – Attenuation of TMM (□) and BMF (○) as a function of frequency

As particles and fluid have the same density and the particles are small, separation of the particles does not occur during use. After standstill a separation is visible, but adequate mixing is obtained after a short time of circulation at maximal speed. The fluid has been in use for several months in closed circuits without visible changes. The addition of an anti-fungal component is advised.

The occurrence of gas bubbles can be prevented by circulating the fluid regularly or by exposing it to a low pressure before use. The first measure was taken in one flow rig: circulating the fluid during 10 s every 10 min resulted in disappearance of bubbles after one week. At the maximum flow rate in this rig (30 ml s^{-1}) no bubbles were observed. In another flow rig half of the fluid was exposed to a low pressure (1 kPa) and stirred for 1 h prior to use. In this case a bubble-free flow of 80 ml s^{-1} was obtained.

D.4.2 Tube

The **tube** needs support to keep it straight and under tension. The **tube** is slightly elliptic, the difference between largest and smallest diameter was 10 % of the largest diameter. The cross-sectional area was found to be equal to 0,47 cm². This is equal to that of a virgin **tube**. Applying pressure inside the **tube** causes expansion, less for a **tube** inside **TMM** than in a free tube. In order to keep changes in cross-section below 1 % the applied pressure has to be less than 16 kPa (**tube** in **TMM**) or 6 kPa (free **tube**).

In a test object for high flows, an **inlet length** of 500 mm was used. In this test object, a linear calibration line through the origin was obtained up to $Re = 2\ 000$, the deviation being less than $\pm 5\ %$ of the measured value.

The density of the **tube** wall is 886 kg m⁻³.

The sound velocity is 1 556 m s⁻¹.

The attenuation as function of frequency is given in figure D.4.

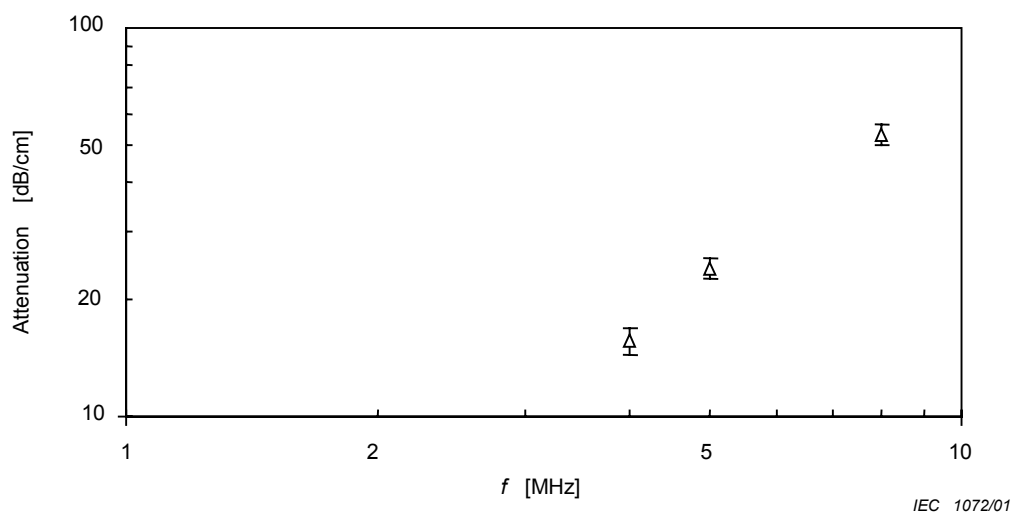
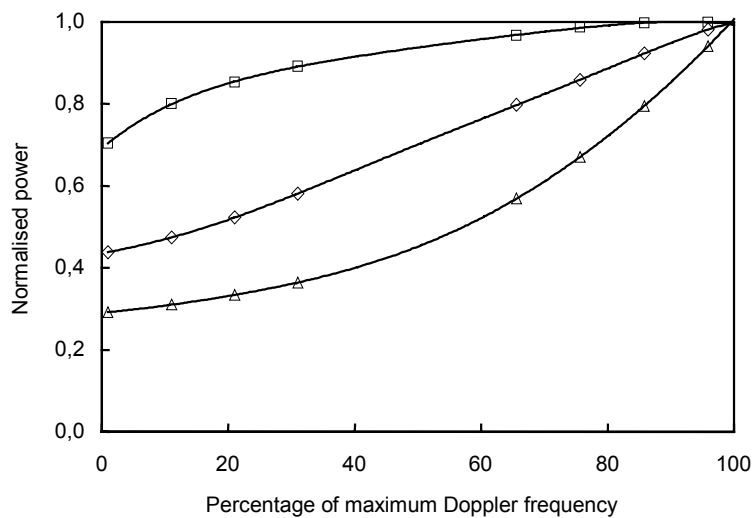

Figure D.4 – Attenuation of ultrasound by material of tube wall, as a function of frequency

Figure D.5 shows the calculated spectral distortion at homogeneous insonation over the full lumen of **tube** and a parabolic flow profile.



IEC 1073/01

NOTE The lines refer to operation frequencies of 2 MHz (□), 5 MHz (◇) and 10 MHz (△). This is a result of theoretical calculation.

Figure D.5 – Deformation of velocity spectrum of parabolic flow by attenuation due to tube wall (wall thickness 1,5 mm)

In connection with the properties of the **tube**, it should be noted that this **tube** introduces rather strong attenuation near the side walls. Refraction is negligible.

D.4.3 Tissue-mimicking material (TMM)

The density is $1\,047\text{ kg m}^{-3}$ ($-0,2\text{ kg m}^{-3}\text{ }^{\circ}\text{C}^{-1}$)

The sound velocity is $1\,540\text{ m s}^{-1}$ (temperature coefficient not determined)

The characteristic acoustic impedance is $1,61 \times 10^6\text{ kg m}^{-2}\text{ s}^{-1}$

Figures D.6 and D.7 respectively show backscatter and attenuation. The equality of different preparations of **TMM** is satisfactory, with the exception of backscatter. However, backscatter of the **TMM** is not very important for a flow test object.

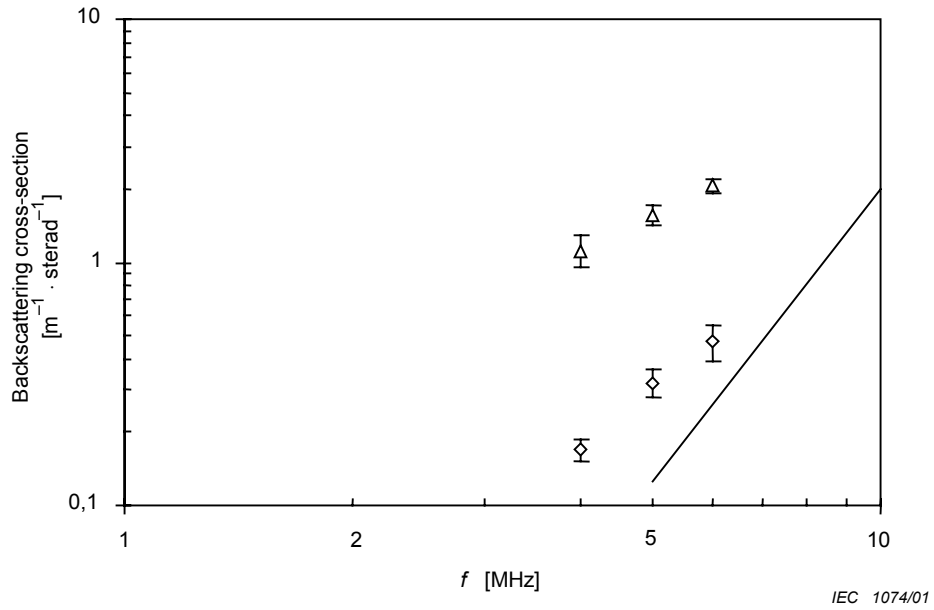

NOTE The line indicates target value.

Figure D.6 – Backscattering coefficient of two samples of TMM as a function of frequency

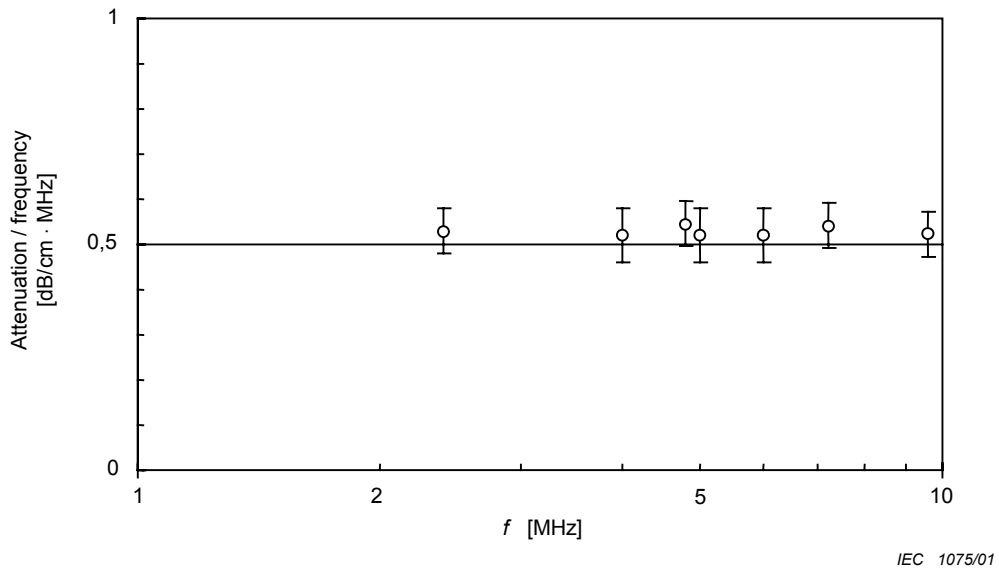

NOTE Drawn line: target values.

Figure D.7 – The quotient of attenuation by TMM (1-way passage) and frequency as a function of frequency

D.5 Stability of the flow Doppler test object

The following parameters are crucial to the application of the **flow Doppler test object**. Therefore the (absence of) variation is documented by stating either the time interval after which a certain change in a parameter occurs, or the time interval after which the change is less than a detection threshold.

D.5.1 Blood-mimicking fluid (BMF)

Backscatter coefficient varies. This is ascribed to formation of clusters of Orgasol particles. On various occasions ranges of 5 dB to 7 dB between various suppliers and methods of handling (sieving, pumping) have been observed. This aspect is the subject of further study.

D.5.2 Tube

The **tube** may change length by 3,5 % in three months. Recalibration of cross-section is recommended after two months. This subject will be studied further, as well as possible changes in acoustic properties of the **tube**.

D.5.3 Tissue-mimicking material (TMM)

The **TMM** can be kept for at least 6 months. If the container leaks, the fluid on top has to be refreshed regularly. Changes of acoustic properties of the **TMM** are not yet known.

D.6 Applications of the flow Doppler test object

One particular scanner was assessed by 5 nominally identical **flow Doppler test objects** and 5 observers (15 combinations, not a full matrix). A number of tests which are detailed in [1], [2] were performed. The following measurements were executed with success:

- colour **penetration depth** (cf. figure D.8);
- pulsed wave Doppler **penetration depth** (both objective and subjective);
- **sample volume position error** (cf. figure D.8);
- **lowest detectable Doppler frequency**;
- **inner diameter of tube** (see note 1);
- **average frequency of the Doppler spectrum** (see note 2);
- **maximum frequency of the Doppler spectrum** (see note 2);
- **volume flow measurement error**(see note 2) .

NOTE 1 Interobserver variability found.

NOTE 2 Variations of 10 % to 20 % between **flow Doppler test objects** and observers exist.

Highest detectable Doppler frequency cannot be tested, as the maximum achievable velocity in the **flow Doppler test object** is too low for the used Doppler system.

Doppler angle error measurements are too sensitive to probe placement ($\pm 2^\circ$) to be of practical significance.

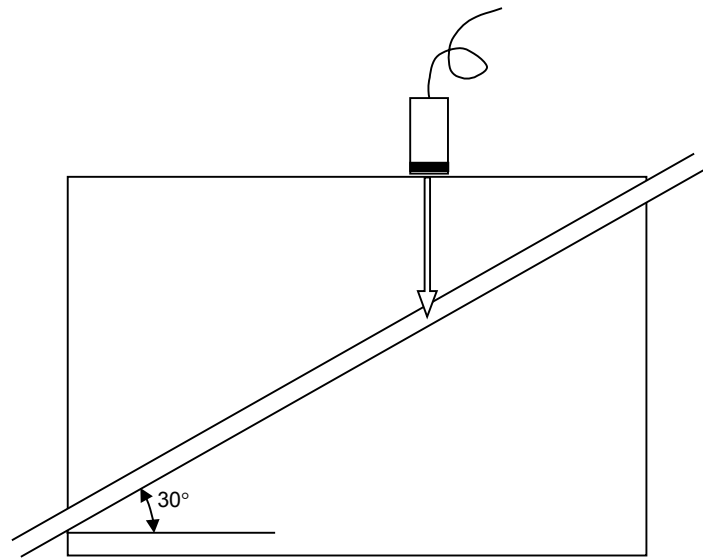

IEC 1076/01

NOTE The Doppler transducer is moved over the **flow Doppler test object** until the signal from the **BMF** in the **tube** is just discernible from the noise. The same geometry is used for assessing **sample volume position error**.

Figure D.8 – Testing for penetration depth

Annex E
(informative)

Schematic diagram of a possible flow circuit

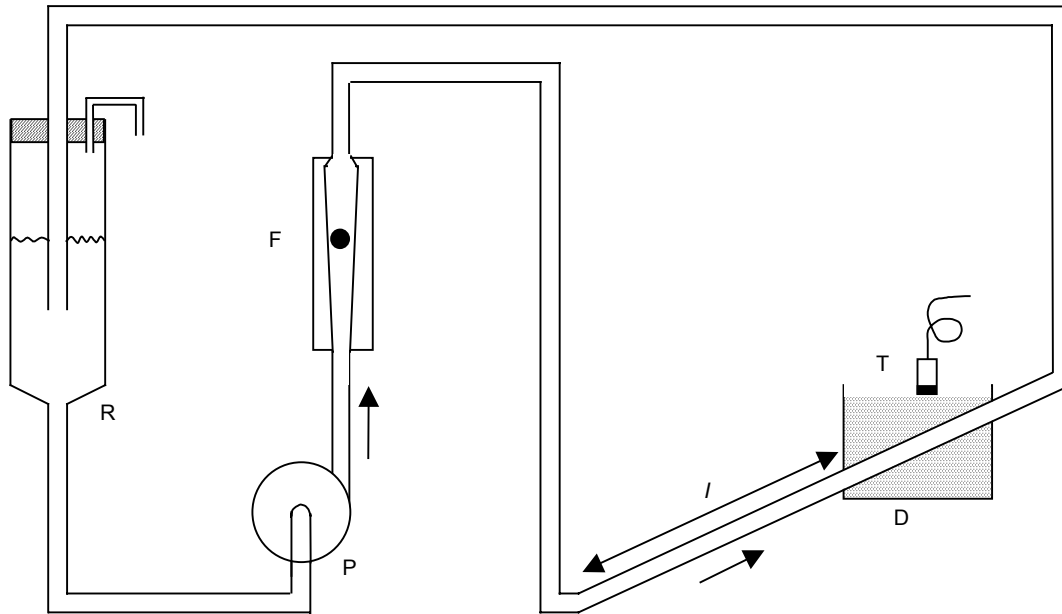

IEC 1077/01

Key

- F flowmeter
- P pump
- R reservoir
- I inlet length
- D flow Doppler test object
- T transducer

Figure E.1 – Schematic diagram of a possible flow circuit,
showing the place of the flow Doppler test object

Annex F (informative)

Measuring methods

Sound velocity is measured from time of flight of ultrasound pulses through the material investigated compared to the time of flight through distilled water [11].

Attenuation is measured from the diminishing of the sound intensity after insertion of a plane parallel sample in an ultrasound beam in water. A correction is applied for the reflection of the ultrasound at the interfaces [11].

Density is measured by weighing a known volume of material or by floating some material in a fluid of known density.

Characteristic acoustic impedance is calculated from the product of density and sound velocity.

The backscatter coefficient is measured by comparing intensity of signals to those of a perfect flat reflector [19], [20].

Viscosity can be measured from the timed collection of **blood-mimicking fluid (BMF)** flowing through a capillary with a diameter in the range 0,5 mm to 2 mm. Other viscometers such as cone and plate viscometers or Couette (coaxial cylinder) viscometers may be used.

The **tube** cross-section can be measured by filling the **tube** with a known amount of fluid and measuring the length of the column. The length of the column can be measured from X-ray photography (using a contrast fluid) or from making a contact with an electrical conductor at known positions. The **inner diameter** of the **tube** can be measured directly with X-ray contrast or from an ultrasound A-scan. Measurements in at least two directions are required.

An indication of the spectral distortion by the wall may be obtained directly by insonating a parabolic flow in the **tube** with a Doppler instrument with a uniform response over a sample volume which is wider than the **tube** [10]. This condition can be fulfilled by placing a long water path between **tube** and the Doppler transducer. Under these conditions a flat spectrum up to the frequency corresponding with the axial velocity is expected. A correction for the spectral response of the Doppler instrument has to be applied. This response can be assessed by the electronic signal injection technique [21]. Deviations from the expected spectrum are ascribed to the distortion by the wall.

The instantaneous deviation of the flow rate from its average value can be measured with an electromagnetic or ultrasonic transit-time flowmeter. Its value can also be estimated from the pulsatile component of the readings of a Doppler velocity system.

Bibliography

- [1] AIUM Standards Committee. *Performance criteria and measurements for Doppler ultrasound devices, technical discussion*. Laurel: American Institute of Ultrasound in Medicine, 1993.
- [2] HOSKINS, PR., SHERRIFF, SB. and EVANS, JA. *Testing of Doppler Ultrasound Equipment*. York, UK: Institute of Physical Sciences in Medicine, 1994, Report No. 70.
- [3] GOSS, SA., JOHNSTON, RL., and DUNN, F. Comprehensive compilation of empirical ultrasonic properties of mammalian tissues. *J. Acoust. Soc. Am.*, 1978, vol. 64, p. 423-457.
- [4] GOSS, SA., JOHNSTON, RL., and DUNN, F. Comprehensive compilation of empirical ultrasonic properties of mammalian tissues II. *J. Acoust. Soc. Am.*, 1980, vol. 68, p. 93-108.
- [5] McDONALD, DA. *Blood flow in arteries*. London: Edward Arnold, 1974.
- [6] SHUNG, KK., YUAN, YW., FEI, DY., and TARBELL, JM. Effect of flow disturbance on ultrasonic backscatter from blood. *J. Acoust. Soc. Am.*, 1984, vol. 75, p.1265-1272.
- [7] TIETJENS, OG. *Applied Hydro- and Aeromechanics*, based on lectures of L. Prandtl. New York: Dover publications, 1957, p. 27, Figure 13.
- [8] SCHLICHTING, H. *Boundary layer theory*. 4th ed. New York: McGraw-Hill, 1962, chap. 16 and 20.
- [9] THOMPSON, RS., ALDIS, GK., and LINNETT, IW. Doppler ultrasound spectral power density distribution: measurement artefacts in steady flow. *Med. & Biol. Eng. & Comput.*, 1990 vol. 28, p. 60-66.
- [10] WINKLER, AJ., WU, J. Correction of intrinsic spectral broadening errors in Doppler peak velocity measurements made with phased sector and linear array transducers. *Ultrasound in Med. & Biol.*, 1995, vol. 21, p. 1035-1039.
- [11] RICKEY, DW., PICOT, PA., and FENSTER, A. A wall-less vessel phantom for Doppler ultrasound studies. *Ultrasound in Med. & Biol.*, 1995, vol. 21, p. 1163-1176.
- [12] Validation of a flow Doppler test object for diagnostic ultrasound scanners. Final report contract MAT-CT 940091 EC, Brussels, 1997.
- [13] MACHI, J., SIGEL, B., BEITLER, JC., COELHO, CU., and JUSTIN, JR. Relation of *in vivo* blood flow to ultrasound echogenicity. *J. Clin. Ultrasound*, 1983, vol. 11, p. 3-10.
- [14] HOSKINS, PR., LOUPAS, T., and McDICKEN, WN. A comparison of the Doppler spectra from human blood and artificial blood used in a flow phantom. *Ultrasound in Med. & Biol.*, 1990, vol. 16, p.141-147.
- [15] KALUZYNSKI, K. Selection of a spectral analysis method for the assessment of velocity distribution based on the spectral distribution of ultrasonic Doppler signals. *Med. & Biol. Eng. & Comput.*, 1989, vol. 27, p. 463-469.
- [16] MADSEN, E., ZAGZEBSKI, JA. and FRANK, GR. Oil in gelatine dispersions for use as ultrasonically tissue-mimicking materials, *Ultrasound in Med. & Biol.*, 1982, vol. 8, p. 277-287.
- [17] VON BIBRA, H., STEMPFLE, HU., POLL, A., et. al. Genauigkeit verschiedener Doppler-techniken in der Erfassung von Flussgeschwindigkeiten, Untersuchungen *in vitro*. *Z. Kardiol.*, 1990, vol. 79, p. 73-82.
- [18] TAMURA, T., COBBOLD, RSC. and JOHNSTON, KW. Quantitative study of steady flow using color Doppler ultrasound. *Ultrasound in Med. & Biol.*, 1991, vol. 17, p. 595-605.
- [19] SIGELMANN, RA. and REID, JM. Analysis and measurement of ultrasound back-scattering from an ensemble of scatterers excited by sine-wave bursts. *J. Acoust. Soc. Am.*, 1973, vol. 53, p. 1351-

- [20] LOCKWOOD, GR., RYAN, LK., HUNT, JW., and FOSTER, FS. Measurement of the ultrasonic properties of vascular tissues and blood from 35-65 MHz. *Ultrasound in Med. & Biol.*, 1991, vol. 17, p. 653-666.
- [21] EVANS, JA., PRICE, R., and LUHANA, F. A novel testing device for Doppler ultrasound equipment. *Phys. Med. Biol.*, 1989, vol. 34, p. 1701-1707.
- [22] TEIRLINCK, CJPM., BEZEMER, RA., KOLLMANN, C., LUBBERS, J., HOSKINS, PR., RAMNARINE, KV., FISH, P., FREDFELDT, K-E., and SCHAARSCHMIDT, UG. Development of an example flow test object and comparison of five of these test objects, constructed in various laboratories. *Ultrasonics*, 1998, vol. 36, p. 653-660.
- [23] RAMNARINE, KV., NASSIRI, DK., HOSKINS, PR. and LUBBERS, J. Validation of a new blood-mimicking fluid for use in Doppler flow test objects. *Ultrasound in Med.& Biol.*, 1998, vol. 24, p. 451-459.
- [24] RAMNARINE, KV., HOSKINS, PR., ROUTH, HF., and DAVIDSON, F. Doppler backscatter properties of a blood-mimicking fluid for Doppler performance assessment. *Ultrasound in Med.& Biol.*, 1999, vol. 25, p. 105-110.
- [25] LUBBERS, J. Application of a new blood-mimicking fluid in a flow Doppler test object. *European Journal of Ultrasound*, 1999, vol. 9, p. 267-276.

The following are provided for information only and are not referenced in the text:

- [26] ATS. *Peripheral vascular flow phantom, model 524 and Doppler cardiac flow phantom model 523*. Bridgeport: ATS laboratories Inc, 404 Knowlton Street, Bridgeport, Connecticut 06608, USA.
- [27] BLACK, RA. and HOW, TV. Pulsed Doppler ultrasound system for the measurement of velocity distributions and flow disturbances in arterial prostheses. *J. Biomed. Eng.*, 1989, vol. 11, p. 35-47.
- [28] BOOTE, EJ. and ZAGZEBSKI, JA. Performance tests of Doppler ultrasound equipment with a tissue and blood-mimicking phantom. *J. Ultrasound Med.*, 1988, vol. 7, p. 137-147.
- [29] BURLEW, MM., MADSEN, EL., ZAGZEBSKI, J., BANJAVIC, RA., and SUM, SW. A new ultrasound tissue equivalent material. *Radiology*, 1980, vol. 134, p. 517-520.²
- [30] FRAYNE, RF., GOWMAN, LM., RICKEY, DW., *et. al.* A geometrically accurate vascular phantom for comparative studies of X-ray, ultrasound and magnetic resonance vascular imaging: construction and geometrical verification. *Med. Phys.*, 1993, Vol. 20, Part 2, p. 415-425.
- [31] GILL, RW. Pulsed Doppler with b-mode imaging for quantitative blood flow measurement. *Ultrasound in Med. & Biol.*, 1979, vol. 5, p. 223-235, 1979.
- [32] GOLDSTEIN, A. Performance tests of Doppler ultrasound equipment with a string phantom. *J. Ultrasound Med.*, 1991, vol. 10, p. 125-139.
- [33] GOLDSTEIN, A. The effect of tank liquid acoustic velocity on Doppler string phantom measurements. *J. Ultrasound Med.*, 1991, vol. 10, p. 141-148.
- [34] HASSLER, D. 82 Messung der Blutgeschwindigkeit, des Blutvolumenstromes und der Aderquerschnittsfläche nach der integralen Ultraschall-Dopplermethode – Vergleich zweier Lösungen. *Ultraschall in der Medizin*, vol. 3, p. 24-29, 1982.

² US Patent No. 4277367 *Phantom Material and Methods*.

- [35] HEIN, IA. and O'BRIEN, WD. A flexible blood flow phantom capable of independently producing constant and pulsatile flow with a predictable spatial flow profile for ultrasound flow measurement validations. *IEEE Trans. Biomed. Engrg.*, 1992, Vol. 39, p. 1111-1122.
- [36] HOLDSWORTH, D., RICKEY, D., DRANGOVA, M., MILLER, DJM., and FENSTER, A. Computer-controlled positive displacement pump for physiological flow simulation. *Med. Biol. Eng. Comput.*, 1991, vol. 29, p. 565-570.
- [37] HOSKINS, PR., ANDERSON, T., and McDICKEN, WN. A computer controlled flow phantom for generation of physiological Doppler waveforms. *Phys. Med. Biol.*, 1989, vol. 34, p. 1709-1717.
- [38] KRABILL, KA., SUNG, HW., TAMURA, T., CHUNG, KJ., YOGANATHAN, AP., and SAHN, DJ. Factors influencing the structure and shape of stenotic and regurgitant jets: an *in vitro* investigation using Doppler color flow mapping and optical flow visualization, *J. Am. Coll. Cardiol.*, 1989, vol. 13, p. 1672-1681.
- [39] LAW, YF., JOHNSTON, KW., ROUTH, HF., and COBBOLD, RSC. On the design and evaluation of a steady flow model for Doppler ultrasound studies. *Ultrasound in Med. & Biol.*, 1989, Vol. 15, p. 505-516.
- [40] LERSKI, RA., DUGGAN, TC., and CHRISTIE, J. A simple tissue-like ultrasound phantom material, *British J. Radiology*, 1982, Vol. 55, p. 156-157.
- [41] LIGHTY, GW., READ, PFK., and PEARLMAN, AS. *In vitro* Doppler flow modeling: Glutaraldehyde fixed red blood cells as a blood analog, *Ultrasonoor Bulletin*, 1983, Abstracts 5th symposium on echocardiology, Rotterdam, vol. 15.
- [42] LUBBERS, J. and VAN DEN BERG, JW. An ultrasonic detector for microgasemboli in a blood flow line, *Ultrasound Med. & Biol.*, 1976, Vol. 2, p. 301-310.
- [43] MADSEN, EL., ZAGZEBSKI, JA., INSANA, MF., BURKE, TM., and FRANK, G. Ultrasonically tissue-mimicking liver including the frequency dependence of backscatter. *Med. Phys.*, 1982, Vol. 9, Part 5, p. 703-710.
- [44] McDICKEN, WN., A versatile test-object for the calibration of ultrasonic Doppler flow instruments. *Ultrasound in Med. & Biol.*, 1986, vol. 12, p. 245-249.
- [45] NEWHOUSE, VL., NATHAN, RS., and HERTZLER, LW. A proposed standard target for ultrasound Doppler gain calibration. *Ultrasound in Med. & Biol.*, 1982, Vol. 8, p. 313-316.
- [46] OATES, CP. Towards an ideal blood analogue for Doppler ultrasound phantoms. *Phys. Med. Biol.*, 1991, vol. 36, p. 1433-1442.
- [47] *Nuclear Associates: Dynamic Doppler flow system 84-327*, Nuclear Associates, Carle Place NY 115-15923.
- [48] POOTS, JK., JOHNSTON, KW., COBBOLD, RSC., and KASSAM, M. Comparison of CW Doppler ultrasound spectra with the spectra derived from a flow visualization model. *Ultrasound in Med. & Biol.*, 1986, Vol. 12, p. 125-133.
- [49] POOTS, K., COBBOLD, RSC., JOHNSTON, KW., *et al.* A new pulsatile flow visualization method using a photochromic dye with application to Doppler ultrasound. *Ann. Biomed. Engrg.*, 1986, vol.14, p. 203-218.
- [50] *RMI: Instruction manual Doppler phantom flow control system, model 425*, Radiation Measurements Inc, P.O. Box 327 Middleton Wisconsin USA, 1989.
- [51] SEO, Y., HONGO, H., KOMATSU, K., SASAKI, H. and LINUMA, K. The effect of attenuation of ultrasonic wave in human tissue on the spectrum of pulsed Doppler signal. *JSUM*, 1982, vol. 427-428.
- [52] TAMURA, T., YOGANATHAN, A. and SAHN, DJ. *In vitro* methods for studying the accuracy of velocity determination and spatial resolution of a color Doppler flow mapping system. *Am. Heart J.*, 1987, vol. 114, p. 152-158.
-

Annex ZA (normative)

Normative references to international publications with their corresponding European publications

This European Standard incorporates by dated or undated reference, provisions from other publications. These normative references are cited at the appropriate places in the text and the publications are listed hereafter. For dated references, subsequent amendments to or revisions of any of these publications apply to this European Standard only when incorporated in it by amendment or revision. For undated references the latest edition of the publication referred to applies (including amendments).

NOTE When an international publication has been modified by common modifications, indicated by (mod), the relevant EN/HD applies.

<u>Publication</u>	<u>Year</u>	<u>Title</u>	<u>EN/HD</u>	<u>Year</u>
IEC 61102	1991	Measurement and characterisation of ultrasonic fields using hydrophones in the frequency range 0,5 MHz to 15 MHz	EN 61102	1993
IEC 61206	1993	Ultrasonics - Continuous-wave Doppler systems - Test procedures	EN 61206	1995
IEC 61895	1999	Ultrasonics - Pulsed Doppler diagnostic systems - Test procedures to determine performance	-	-

BSI — British Standards Institution

BSI is the independent national body responsible for preparing British Standards. It presents the UK view on standards in Europe and at the international level. It is incorporated by Royal Charter.

Revisions

British Standards are updated by amendment or revision. Users of British Standards should make sure that they possess the latest amendments or editions.

It is the constant aim of BSI to improve the quality of our products and services. We would be grateful if anyone finding an inaccuracy or ambiguity while using this British Standard would inform the Secretary of the technical committee responsible, the identity of which can be found on the inside front cover.
Tel: +44 (0)20 8996 9000. Fax: +44 (0)20 8996 7400.

BSI offers members an individual updating service called PLUS which ensures that subscribers automatically receive the latest editions of standards.

Buying standards

Orders for all BSI, international and foreign standards publications should be addressed to Customer Services. Tel: +44 (0)20 8996 9001.
Fax: +44 (0)20 8996 7001. Email: orders@bsi-global.com. Standards are also available from the BSI website at <http://www.bsi-global.com>.

In response to orders for international standards, it is BSI policy to supply the BSI implementation of those that have been published as British Standards, unless otherwise requested.

Information on standards

BSI provides a wide range of information on national, European and international standards through its Library and its Technical Help to Exporters Service. Various BSI electronic information services are also available which give details on all its products and services. Contact the Information Centre.
Tel: +44 (0)20 8996 7111. Fax: +44 (0)20 8996 7048. Email: info@bsi-global.com.

Subscribing members of BSI are kept up to date with standards developments and receive substantial discounts on the purchase price of standards. For details of these and other benefits contact Membership Administration.
Tel: +44 (0)20 8996 7002. Fax: +44 (0)20 8996 7001.
Email: membership@bsi-global.com.

Information regarding online access to British Standards via British Standards Online can be found at <http://www.bsi-global.com/bsonline>.

Further information about BSI is available on the BSI website at <http://www.bsi-global.com>.

Copyright

Copyright subsists in all BSI publications. BSI also holds the copyright, in the UK, of the publications of the international standardization bodies. Except as permitted under the Copyright, Designs and Patents Act 1988 no extract may be reproduced, stored in a retrieval system or transmitted in any form or by any means – electronic, photocopying, recording or otherwise – without prior written permission from BSI.

This does not preclude the free use, in the course of implementing the standard, of necessary details such as symbols, and size, type or grade designations. If these details are to be used for any other purpose than implementation then the prior written permission of BSI must be obtained.

Details and advice can be obtained from the Copyright & Licensing Manager.
Tel: +44 (0)20 8996 7070. Fax: +44 (0)20 8996 7553.
Email: copyright@bsi-global.com.