

BS EN 61481-1:2014



BSI Standards Publication

# Live working — Phase comparators

Part 1: Capacitive type to be used for voltages exceeding 1 kV a.c.

**bsi.**

...making excellence a habit.™

### **National foreword**

This British Standard is the UK implementation of EN 61481-1:2014. It is identical to IEC 61481-1:2014. Together with BS EN 61481-2:2014 it supersedes BS EN 61481:2001, which is withdrawn.

The UK participation in its preparation was entrusted to Technical Committee PEL/78, Tools for live working.

A list of organizations represented on this committee can be obtained on request to its secretary.

This publication does not purport to include all the necessary provisions of a contract. Users are responsible for its correct application.

© The British Standards Institution 2015

Published by BSI Standards Limited 2015.

ISBN 978 0 580 79874 0

ICS 13.260; 29.240.20; 29.260.99

**Compliance with a British Standard cannot confer immunity from legal obligations.**

This British Standard was published under the authority of the Standards Policy and Strategy Committee on 31 January 2015.

### **Amendments/corrigenda issued since publication**

<b>Date</b>	<b>Text affected</b>
-------------	----------------------

---

EUROPEAN STANDARD

**EN 61481-1**

NORME EUROPÉENNE

EUROPÄISCHE NORM

December 2014

ICS 13.260; 29.240.20; 29.260.99

Supersedes EN 61481:2001 (partially)

English Version

**Live working - Phase comparators -  
Part 1: Capacitive type to be used for voltages  
exceeding 1 kV a.c.  
(IEC 61481-1:2014)**

Travaux sous tension - Comparateurs de phase -  
Partie 1: Type capacitif pour usage sur des tensions  
alternatives de plus de 1 kV  
(CEI 61481-1:2014)

Arbeiten unter Spannung - Phasenvergleichler -  
Teil 1: Kapazitive Ausführung für Wechselspannungen  
über 1 kV  
(IEC 61481-1:2014)

This European Standard was approved by CENELEC on 2014-11-28. CENELEC members are bound to comply with the CEN/CENELEC Internal Regulations which stipulate the conditions for giving this European Standard the status of a national standard without any alteration.

Up-to-date lists and bibliographical references concerning such national standards may be obtained on application to the CEN-CENELEC Management Centre or to any CENELEC member.

This European Standard exists in three official versions (English, French, German). A version in any other language made by translation under the responsibility of a CENELEC member into its own language and notified to the CEN-CENELEC Management Centre has the same status as the official versions.

CENELEC members are the national electrotechnical committees of Austria, Belgium, Bulgaria, Croatia, Cyprus, the Czech Republic, Denmark, Estonia, Finland, Former Yugoslav Republic of Macedonia, France, Germany, Greece, Hungary, Iceland, Ireland, Italy, Latvia, Lithuania, Luxembourg, Malta, the Netherlands, Norway, Poland, Portugal, Romania, Slovakia, Slovenia, Spain, Sweden, Switzerland, Turkey and the United Kingdom.



European Committee for Electrotechnical Standardization  
Comité Européen de Normalisation Electrotechnique  
Europäisches Komitee für Elektrotechnische Normung

**CEN-CENELEC Management Centre: Avenue Marnix 17, B-1000 Brussels**

## Foreword

The text of document 78/1051/FDIS, future edition 1 of IEC 61481-1, prepared by IEC/TC 78 "Live working" was submitted to the IEC-CENELEC parallel vote and approved by CENELEC as EN 61481-1:2014.

The following dates are fixed:

- latest date by which the document has to be implemented at national level by publication of an identical national standard or by endorsement (dop) 2015-08-28
- latest date by which the national standards conflicting with the document have to be withdrawn (dow) 2017-11-28

This document supersedes EN 61481:2001 (partially).

Attention is drawn to the possibility that some of the elements of this document may be the subject of patent rights. CENELEC [and/or CEN] shall not be held responsible for identifying any or all such patent rights.

## Endorsement notice

The text of the International Standard IEC 61481-1:2014 was approved by CENELEC as a European Standard without any modification.

In the official version, for Bibliography, the following notes have to be added for the standards indicated:

IEC 60071-1:2006	NOTE	Harmonized as EN 60071-1:2006 (not modified).
IEC 60743:2013	NOTE	Harmonized as EN 60743:2013 (not modified).
IEC 61235:1993	NOTE	Harmonized as EN 61235:1995 (modified).
IEC 61936-1:2010	NOTE	Harmonized as EN 61936-1:2010 (modified).
ISO/IEC 17025	NOTE	Harmonized as EN ISO/IEC 17025 (not modified).

## Annex ZA (normative)

### Normative references to international publications with their corresponding European publications

The following documents, in whole or in part, are normatively referenced in this document and are indispensable for its application. For dated references, only the edition cited applies. For undated references, the latest edition of the referenced document (including any amendments) applies.

NOTE 1 When an International Publication has been modified by common modifications, indicated by (mod), the relevant EN/HD applies.

NOTE 2 Up-to-date information on the latest versions of the European Standards listed in this annex is available here: [www.cenelec.eu](http://www.cenelec.eu)

<u>Publication</u>	<u>Year</u>	<u>Title</u>	<u>EN/HD</u>	<u>Year</u>
CISPR 11	-	Industrial, scientific and medical equipment - Radio-frequency disturbance characteristics - Limits and methods of measurement	EN 55011	-
IEC 60060-1	2010	High-voltage test techniques - Part 1: General definitions and test requirements	EN 60060-1	2010
IEC 60068-1	-	Environmental testing - Part 1: General and guidance	EN 60068-1	-
IEC 60068-2-6	-	Environmental testing - Part 2-6: Tests - Test Fc: Vibration (sinusoidal)	EN 60068-2-6	-
IEC 60068-2-14	-	Environmental testing - Part 2-14: Tests - Test N: Change of temperature	EN 60068-2-14	-
IEC 60068-2-31	-	Environmental testing - Part 2-31: Tests - Test Ec: Rough handling shocks, primarily for equipment-type specimens	EN 60068-2-31	-
IEC 60068-2-75	-	Environmental testing - Part 2-75: Tests - Test Eh: Hammer tests	EN 60068-2-75	-
IEC 60304	-	Standard colours for insulation for low-frequency cables and wires	HD 402 S2	-
IEC 60417-DB	-	Graphical symbols for use on equipment	-	-
IEC 60942	-	Electroacoustics - Sound calibrators	EN 60942	-
IEC 61000-4-2	-	Electromagnetic compatibility (EMC) - Part 4-2: Testing and measurement techniques - Electrostatic discharge immunity test	EN 61000-4-2	-
IEC 61000-4-3	-	Electromagnetic compatibility (EMC) - Part 4-3: Testing and measurement techniques - Radiated, radio-frequency, electromagnetic field immunity test	EN 61000-4-3	-
IEC 61260	-	Electroacoustics - Octave-band and fractional-octave-band filters	EN 61260	-

<u>Publication</u>	<u>Year</u>	<u>Title</u>	<u>EN/HD</u>	<u>Year</u>
IEC 61318	-	Live working - Conformity assessment applicable to tools, devices and equipment	EN 61318	-
IEC 61326-1	-	Electrical equipment for measurement, control and laboratory use - EMC requirements - Part 1: General requirements	EN 61326-1	-
IEC 61477	-	Live working - Minimum requirements for the utilization of tools, devices and equipment	EN 61477	-
IEC 61672-1	-	Electroacoustics - Sound level meters - Part 1: Specifications	EN 61672-1	-
ISO 354	-	Acoustics - Measurement of sound absorption in a reverberation room	EN ISO 354	-
ISO 3744	2010	Acoustics - Determination of sound power levels and sound energy levels of noise sources using sound pressure - Engineering methods for an essentially free field over a reflecting plane	EN ISO 3744	2010
ISO 3745	-	Acoustics - Determination of sound power levels and sound energy levels of noise sources using sound pressure - Precision methods for anechoic rooms and hemi-anechoic rooms	EN ISO 3745	-
CIE 15	-	Colorimetry	-	-

## CONTENTS

INTRODUCTION.....	9
1 Scope.....	10
2 Normative references .....	10
3 Terms and definitions .....	11
4 Requirements .....	15
4.1 Indication .....	15
4.2 Functional requirements.....	16
4.2.1 Clear indication .....	16
4.2.2 Distance range .....	17
4.2.3 Clear perceptibility.....	17
4.2.4 Temperature and humidity dependence of the indication.....	17
4.2.5 Frequency dependence .....	18
4.2.6 Response time.....	18
4.2.7 Power source dependability .....	18
4.2.8 Testing element.....	18
4.2.9 Time rating .....	19
4.3 Electrical requirements .....	19
4.3.1 Insulating material .....	19
4.3.2 Protection against bridging .....	19
4.3.3 Resistance against sparking .....	19
4.3.4 Insulating element of phase comparator as a complete device.....	19
4.3.5 Indicator casing .....	19
4.4 Mechanical requirements .....	20
4.4.1 General .....	20
4.4.2 Design .....	20
4.4.3 Dimensions, construction.....	22
4.4.4 Grip force and deflection .....	23
4.4.5 Vibration resistance .....	23
4.4.6 Drop resistance .....	23
4.4.7 Shock resistance .....	23
4.5 Marking.....	23
4.6 Instructions for use .....	24
4.7 Requirements in the case of reasonably foreseeable misuse during live working.....	24
4.7.1 Voltage selection .....	24
4.7.2 Frequency selection .....	24
4.7.3 Channel selection for wireless connection .....	24
5 Tests.....	24
5.1 General.....	24
5.1.1 Testing provisions .....	24
5.1.2 Atmospheric conditions.....	25
5.1.3 Tests under wet conditions .....	25
5.1.4 Type test .....	25
5.1.5 Test methods.....	26
5.2 Function tests .....	26

5.2.1	Description of the test set-up and general pass criteria.....	26
5.2.2	Clear indication .....	32
5.2.3	Distance range for two-pole phase comparators with wireless connection .....	34
5.2.4	Electromagnetic compatibility (EMC) .....	34
5.2.5	Influence of electric interference fields.....	35
5.2.6	Clear perceptibility.....	37
5.2.7	Frequency dependence .....	45
5.2.8	Response time.....	46
5.2.9	Power source dependability .....	47
5.2.10	Check of testing element .....	47
5.2.11	Time rating of single-pole phase comparator .....	47
5.2.12	Time rating of two-pole wireless phase comparators.....	48
5.3	Dielectric tests .....	48
5.3.1	Insulating material for tubes and rods .....	48
5.3.2	Protection against bridging for indoor/outdoor type phase comparators .....	49
5.3.3	Protection against bridging for outdoor type phase comparator .....	52
5.3.4	Spark resistance.....	54
5.3.5	Leakage current for phase comparator as a complete device.....	56
5.4	Mechanical tests .....	58
5.4.1	Visual and dimensional inspection .....	58
5.4.2	Grip force and deflection for phase comparator as a complete device .....	59
5.4.3	Vibration resistance .....	59
5.4.4	Drop resistance .....	60
5.4.5	Shock resistance .....	61
5.4.6	Climatic resistance .....	61
5.4.7	Durability of markings .....	63
5.5	Test for reasonably foreseeable misuse during live working.....	63
5.5.1	Voltage selection (where relevant).....	63
5.5.2	Frequency selection (where relevant) .....	63
5.5.3	Channel selection for wireless connection (where relevant) .....	63
6	Conformity assessment of phase comparators having completed the production phase .....	64
7	Modifications .....	64
	Annex A (normative) Instructions for use .....	65
	Annex B (normative) Suitable for live working; double triangle (IEC 60417-5216 (2002-10)).....	67
	Annex C (normative) Chronology of type tests .....	68
	Annex D (normative) Classification of defects and tests to be allocated .....	70
	Annex E (informative) Information and guidelines on the use of the limit mark and of a contact electrode extension .....	72
	E.1 General.....	72
	E.2 Situation when using a phase comparator as a complete device .....	72
	E.3 Situation when using a phase comparator as a separate device.....	76
	Annex F (informative) Rationale for the classification of defects.....	78
	Annex G (informative) In-service care .....	80
	Bibliography.....	81



Figure 1 – Illustration of different elements and different principles of functioning of phase comparators .....	21
Figure 2 – Location of allowed conductive parts within the minimum length of the insulating element of a pole of a phase comparator as a complete device.....	22
Figure 3 – Test set-up for clear indication with the ball electrode in front of its ring electrode .....	28
Figure 4 – Test set-up for clear indication with the ball electrode behind its ring electrode .....	29
Figure 5 – Positioning of a pole of the phase comparator in relation to a ball and ring test arrangement.....	31
Figure 6 – Examples of suitable means for ensuring appropriate contact between a contact electrode and the ball electrode.....	31
Figure 7 – Test set-up for clear perceptibility of visual indication .....	38
Figure 8 – Test set-up for measurement of clear perceptibility of visual indication in the case of an indicator unit.....	40
Figure 9 – Test set-up for clear perceptibility of audible indication .....	42
Figure 10 – Test set-up for measurement of clear perceptibility of audible indication in the case of indicator units .....	44
Figure 11 – Test arrangements and dimensions of the bars for protection against bridging .....	49
Figure 12 – Electrical connection of the bars .....	51
Figure 13 – Surface stress test .....	51
Figure 14 – Radial and surface stress test.....	52
Figure 15 – Test arrangement for testing bridging protection of outdoor type phase comparator .....	54
Figure 16 – Arrangement for leakage current test under dry conditions for phase comparator as a complete device.....	57
Figure 17 – Arrangement for leakage current tests under wet conditions for phase comparator as a complete device.....	58
Figure 18 – Test for grip force.....	59
Figure 19 – Drop resistance test – Diagonal position .....	61
Figure 20 – Curve of test cycle for climatic resistance.....	62
Figure E.1 – Insulating element of a pole of a phase comparator as a complete device .....	72
Figure E.2 – Example of positioning of a pole of a phase comparator in contact with a live part without obstacles from other live parts.....	73
Figure E.3 – Example of incorrect positioning of a pole of a phase comparator with the limit mark between two live parts .....	74
Figure E.4 – Usual ways of managing the design or the use of the phase comparator for maintaining the insulation distance between the limit mark and the hand guard .....	75
Figure E.5 – Usual ways of managing the use of the phase comparator as a separate device for assuring the appropriate insulation for the worker.....	77
Table 1 – Climatic condition ranges .....	18
Table 2 – Minimum length of the insulating element ( $L_i$ ) of a phase comparator as a complete device.....	22
Table 3 – Dimensioning of the ball and ring test set-up.....	30
Table 4 – Test series and conditions for clear indication .....	33
Table 5 – Test series and conditions for influence of electric interference fields.....	36

Table 6 – Type of test .....	49
Table 7 – Distance $d_1$ for the bridging test set-up .....	50
Table 8 – Dimensions for the concentric rings and band electrodes .....	52
Table C.1 – Sequential order for performing type tests <sup>a</sup> .....	68
Table C.2 – Type tests out of sequence .....	69
Table D.1 – Classification of defects and associated requirements and tests .....	70
Table E.1 – Recommended minimum lengths from the limit mark to the contact electrode ( $A_i$ ) .....	75
Table F.1 – Rationale for the classification of defects .....	78
Table G.1 – In-service testing .....	80

## INTRODUCTION

This International Standard has been prepared in accordance with the requirements of IEC 61477.

Taking into consideration the two different functioning principles of portable *phase comparators* of capacitive type available on the market, the maximum a.c. *nominal voltage* to be associated with each of them has been considered for delimiting the scope of this standard.

The following table presents the rationale for the resulting maximum *nominal voltage* to be associated with each functioning principle of *phase comparator of capacitive type*.

Functioning principle	Maximum nominal voltage kV rms	Rationale
Single-pole <i>phase comparators</i> operating with a memory system	36	<ul style="list-style-type: none"> <li>– With this principle of functioning, the <i>clear indication</i> of the <i>phase comparator</i> is limited by the <i>memory holding time</i>.</li> <li>With higher <i>nominal voltages</i>, the distance between phases of the installation increases and the time necessary to move the pole of the <i>phase comparator</i> between the two parts to be compared becomes the limitation.</li> </ul>
Two-pole <i>phase comparators</i> operating with a wireless connection	245	<ul style="list-style-type: none"> <li>– With this principle of functioning, there is no theoretical limit for the maximum <i>nominal voltage</i>.</li> <li>– The definition of 245 kV corresponds to the present limit of validation of the electric test set-up.</li> </ul>

The product covered by this standard may have an impact on the environment during some or all stages of its life cycle. These impacts can range from slight to significant, be short-term or long-term, and occur at the global, regional or local level.

In terms of environmental improvement, this standard includes neither requirements nor test provisions for the manufacturers of the product nor recommendations to the users of the product. However, all parties intervening in its design, manufacture, packaging, distribution, use, maintenance, repair, reuse, recovery and disposal are invited to take account of environmental considerations.

## LIVE WORKING – PHASE COMPARATORS –

### Part 1: Capacitive type to be used for voltages exceeding 1 kV a.c.

#### 1 Scope

This part of IEC 61481 is applicable to portable *phase comparators* of capacitive type to be used on electrical systems for voltages exceeding 1 kV a.c. and frequencies of 50 Hz and/or 60 Hz.

This standard is applicable to:

- single-pole *phase comparators* of capacitive type operating with a memory system up to 36 kV a.c.,
- two-pole *phase comparators* of capacitive type operating with a wireless connection up to 245 kV a.c.

This standard is applicable to *phase comparators* of capacitive type used in contact with the bare conductive parts to be compared:

- as a complete device including its *insulating element* or
- as a separate device, adaptable to an *insulating stick* which, as a separate tool, is not covered by this standard.

NOTE Some parts such as the *contact electrode* or the *insulating element* of a *phase comparator* as a complete device may be dismantled.

Some restrictions on their use are applicable in the case of factory-assembled switchgear and on overhead systems of electrified railways (see Annex A).

A device that is designed to provide other functions than phase comparison is a different device and is not covered by this standard. For example a device designed to be also used as a voltage detector is not covered by this standard (see Annex A).

Products designed and manufactured according to this standard contribute to the safety of users provided they are used by persons trained for the work, in accordance with the hot stick working method and the instructions for use.

Except when otherwise specified, all the voltages defined in this standard refer to phase-to-phase voltages of three-phase systems. In other systems, the applicable phase-to-phase or phase-to-earth (ground) voltages should be used to determine the operating voltage.

#### 2 Normative references

The following documents, in whole or in part, are normatively referenced in this document and are indispensable for its application. For dated references, only the edition cited applies. For undated references, the latest edition of the referenced document (including any amendments) applies.

CISPR 11, *Industrial, scientific and medical equipment – Radio-frequency disturbance characteristics – Limits and methods of measurement*

IEC 60060-1:2010, *High-voltage test techniques – Part 1: General definitions and test requirements*

IEC 60068-1, *Environmental testing – Part 1: General and guidance*

IEC 60068-2-6, *Environmental testing – Part 2-6: Tests – Test Fc: Vibration (sinusoidal)*

IEC 60068-2-14, *Environmental testing – Part 2-14: Tests – Test N: Change of temperature*

IEC 60068-2-31, *Environmental testing – Part 2-31: Tests – Test Ec: Rough handling shocks, primarily for equipment-type specimens*

IEC 60068-2-75, *Environmental testing – Part 2-75: Tests – Test Eh: Hammer tests*

IEC 60304, *Standard colours for insulation for low-frequency cables and wires*

IEC 60417, *Graphical symbols for use on equipment* (Available from: <http://www.graphical-symbols.info/equipment>)

IEC 60942, *Electroacoustics – Sound calibrators*

IEC 61000-4-2, *Electromagnetic compatibility (EMC) – Part 4-2: Testing and measurement techniques – Electrostatic discharge immunity test*

IEC 61000-4-3, *Electromagnetic compatibility (EMC) – Part 4-3: Testing and measurement techniques – Radiated, radio-frequency, electromagnetic field immunity test*

IEC 61260, *Electroacoustics – Octave-band and fractional-octave-band filters*

IEC 61318, *Live working – Conformity assessment applicable to tools, devices and equipment*

IEC 61326-1, *Electrical equipment for measurement, control and laboratory use – EMC requirements – Part 1: General requirements*

IEC 61477, *Live working – Minimum requirements for the utilization of tools, devices and equipment*

IEC 61672-1, *Electroacoustics – Sound level meters – Part 1: Specifications*

ISO 354, *Acoustics – Measurement of sound absorption in a reverberation room*

ISO 3744:2010, *Acoustics – Determination of sound power levels and sound energy levels of noise sources using sound pressure – Engineering method for an essentially free-field over a reflecting plane*

ISO 3745, *Acoustics – Determination of sound power levels and sound energy levels of noise sources using sound pressure – Precision methods for anechoic and hemi-anechoic rooms*

CIE 15, *Colorimetry*

### **3 Terms and definitions**

For the purposes of this document, the terms and definitions given in IEC 61318, as well as the following apply.

### 3.1

#### **accessory**

supplementary item not necessary for the functioning of the *phase comparator* and provided by the manufacturer to facilitate its use under certain operating conditions

Note 1 to entry: An *accessory* is not considered as a part of a device. Without the *accessory*, the device is still functional. An item that is required each time a device is used is not an *accessory* but a part of the device which may be disassembled.

Note 2 to entry: For example an *accessory* is used to lengthen the handle, to improve the efficiency of the *contact electrode*, to enable the *contact electrode* to reach the parts to be compared, etc.

### 3.2

#### **active signal**

visual phenomenon, and optionally audible phenomenon, whose presence, absence or variation is considered as representing information on the condition “correct phase relationship” or “incorrect phase relationship”

Note 1 to entry: A signal indicating that the *phase comparator* is ready to operate is not considered as an *active signal*.

[SOURCE: IEC 60050-101:1998, 101-12-02, modified – the definition of “signal” has been modified to fit the specific context of diagnostic of phase relationship and Note 1 to entry has been added.]

### 3.3

#### **adaptor**

part of a *phase comparator* as a separate device which permits attachment of an *insulating stick*

### 3.4

#### **clear indication**

unambiguous detection and indication of “incorrect phase relationship” and/or “correct phase relationship” between the parts to be compared

### 3.5

#### **clear perceptibility**

case when the indication is unmistakably discernible by the user under specific environmental conditions when the *phase comparator* is in its operating position

### 3.6

#### **contact electrode**

bare conductive part of the *phase comparator* which establishes the electric connection to the part to be compared

### 3.7

#### **contact electrode extension**

externally insulated conductive part to enable the *contact electrode* to reach the parts of the installation to be compared

Note 1 to entry: For a certain installation configuration, the *contact electrode extension* is used to increase the *insertion depth* (see Figure 1d).

Note 2 to entry: The *contact electrode extension* is an *accessory* of the *phase comparator*.

### 3.8

#### **end fittings**

part of an *insulating stick* permanently fitted to the end of an insulating tube or rod

[SOURCE: IEC 60050-651:2014, 651-22-02]

### 3.9

#### **family of phase comparators**

for testing purposes, a group of *phase comparators*, delimited by a minimum and a maximum *rated voltage* and/or by the two frequencies (50 Hz and 60 Hz), that are identical in design (including dimensions) and only differ by their *nominal voltages* or *nominal voltage ranges* and/or their nominal frequency

### 3.10

#### **hand guard**

distinctive physical guard separating the handle of a *phase comparator* as a complete device from its *insulating element*

Note 1 to entry: The purpose of a *hand guard* is to prevent the hands from slipping and passing into contact with the *insulating element*.

### 3.11

#### **indicator**

part of the *phase comparator* that indicates the status of the phase relationship between two parts to be compared

Note 1 to entry: In the case of single-pole *phase comparators*, the *indicator* also indicates that the *phase comparator* is ready to be moved to the second part to be compared ("memory ready").

Note 2 to entry: In the case of two-pole-wireless *phase comparators*, the *indicator* also indicates the communication status.

### 3.12

#### **indicator unit**

additional unit of a two-pole *phase comparator* with wireless connection, normally intended to be hand-held and which is either an indicator or repeater that brings the indication and possibly other information close to the user

### 3.13

#### **indoor type**

*phase comparator* designed for use in dry conditions, normally indoors

### 3.14

#### **insertion depth**

$A_i$

distance between the *limit mark* and the top of the *contact electrode* for a *phase comparator* as a complete device

### 3.15

#### **insulating element**

part of a *phase comparator* as a complete device that provides adequate safety distance and insulation to the user

### 3.16

#### **insulating stick**

insulating tool made essentially of an insulating tube and/or rod with *end fittings*

Note 1 to entry: For phase comparison, an *insulating stick* is intended to be attached to a *phase comparator* as a separate device in order to provide the length to reach the installation to be tested and adequate safety distance and insulation to the user.

[SOURCE: IEC 60050-651:2014, 651-22-01, modified – the Note 1 to entry has been added.]

### 3.17

#### **interference field**

superposed electric field which may affect the indication

Note 1 to entry: The *interference field* may result from the parts to be compared or other adjacent parts and may have any phase relationship.

Note 2 to entry: The extreme cases for the tests are:

- an in-phase *interference field*. This occurs as a result of the dimensions and/or configuration of the parts of the installation to be compared or of adjacent parts of the installation having voltages in the same phase as the parts to be compared;
- an *interference field* in phase opposition. This occurs as a result of the adjacent parts of the installation having voltages in phase opposition to the parts to be compared.

### 3.18

#### limit mark

distinctive location or mark to indicate to the user the physical limit to which the *phase comparator* may be inserted between live parts or may touch them

### 3.19

#### maintenance test

test carried out periodically on a device or equipment to ascertain and, if necessary, make certain adjustments to ensure that its performance remains within specified limits

[SOURCE: IEC 60050-151:2001, 151-16-25, modified – the definition has been modified to fit the specific context of maintenance of device or equipment.]

### 3.20

#### memory holding time

for a single-pole *phase comparator*, maximum available time to contact the second part to be compared, after the indication “memory ready” appears when the *phase comparator* is in contact with the first part to be tested

### 3.21

#### nominal voltage

$U_n$

suitable approximate value of voltage used to identify a system or device

Note 1 to entry: The *nominal voltage* of the *phase comparator* is a parameter associated with its *clear indication*. When a *phase comparator* has more than one *nominal voltage*, or a *nominal voltage* range the limit values of the *nominal voltage* range are named  $U_{n \min}$  and  $U_{n \max}$ .

[SOURCE: IEC 600500-601:1985, 601-01-21, modified – the definition has been modified to fit the specific context of device or equipment and Note 1 to entry has been added.]

### 3.22

#### outdoor type

*phase comparator* designed for use in wet conditions, either indoors or outdoors

### 3.23

#### permanent contact electrode extension

externally insulated conductive element located between the *indicator* and the *contact electrode* of some designs of *phase comparator* to move back the *indicator* from the live part to be compared

Note 1 to entry: The *permanent contact electrode extension* may contain impedances.

Note 2 to entry: The *permanent contact electrode extension* is not an *accessory*.

### 3.24

#### phase comparator

portable device used to provide clear evidence of the presence or the absence of the correct phase relationship between two energized parts at the same *nominal voltage* and frequency



[SOURCE: IEC 60050-651:2014, 651-24-03, modified – the definition has been modified to specify that the device herein defined is a portable device.]

### 3.25

#### **phase comparator of capacitive type** **capacitive phase comparator**

device whose operation is based on the current passing through the stray capacitance to earth

Note 1 to entry: *Phase comparators* of capacitive type are either two-pole *phase comparators* operating with a wireless connection or single-pole *phase comparators* operating with a memory system.

Note 2 to entry: *Phase comparators* of capacitive type mainly work on the basis of angle measurement (frequency-based).

### 3.26

#### **protection against bridging**

protection against flashover or breakdown, when the insulation between the parts of the installation, at different potentials, is reduced by the presence of the *phase comparator*

### 3.27

#### **rated voltage**

$U_r$

value of voltage to which certain operating specifications are referred

Note 1 to entry: The *rated voltage* of the *phase comparator* is the voltage selected from IEC 60071-1:2006, Tables 2 and 3, column 1, which should either be equal to the *nominal voltage* (or the highest *nominal voltage* of its *nominal voltage* range), or the next higher voltage selected from those tables.

### 3.28

#### **response time**

delay between the time when the *phase comparator* makes contact with the second part to be compared and the relevant *clear indication*

### 3.29

#### **testing element**

built-in element or separate device, by means of which the functioning of the *phase comparator* can be checked by the user

[SOURCE: IEC 60743:2013, 11.3.7, modified – the definition has been modified to specify its application to the *phase comparator*.]

### 3.30

#### **threshold parameter**

minimum phase angle  $\varphi_p$  between the two parts to be compared which gives a change of the status of the *active signal*

### 3.31

#### **wireless connecting system**

communication system used to exchange information between the different units of a *phase comparator* without physical link

## 4 Requirements

### 4.1 Indication

The *phase comparator* shall clearly indicate the state "incorrect phase relationship" and/or "correct phase relationship" by means of the change of the status of one or more *active signals*.

The indication shall be visual. An audible indication may be additional.

For a *phase comparator* with *nominal voltage* above 36 kV it is recommended to have both visual and audible indication.

In the case of a single-pole *phase comparator*, the state “memory ready” shall be indicated.

In the case of a two-pole *phase comparator* operating with wireless connection the communication status shall be indicated.

## 4.2 Functional requirements

### 4.2.1 Clear indication

#### 4.2.1.1 General

The following requirements apply when both parts to be compared have the same *nominal voltage* and frequency.

The indication “incorrect phase relationship” shall not appear for an angle difference up to  $\pm 10^\circ$ .

The indication “correct phase relationship” shall not appear for an angle difference above  $\pm 30^\circ$ ,  $\pm 60^\circ$  or  $\pm 110^\circ$  according to the class of the *phase comparator*.

To fulfil the above requirements, the *threshold parameter* shall satisfy the following relationship:

Class A:  $\pm 10^\circ < \varphi_p \leq \pm 30^\circ$

Class B:  $\pm 10^\circ < \varphi_p \leq \pm 60^\circ$

Class C:  $\pm 10^\circ < \varphi_p \leq \pm 110^\circ$ , see Note 1.

Class D: If it is not possible to use any of the above-mentioned classes, the manufacturer and the customer shall reach an agreement to set the appropriate value of the phase-angle difference. In such a case the upper limit of the *threshold parameter* shall exceed the one of class C.

For *phase comparators* with one *nominal voltage*,  $U_{n \max}$  equals  $U_{n \min}$ .

NOTE 1 It has been recognized that for networks with small angle differences a device of class C could permit increasing the *memory holding time*.

NOTE 2 The required phase angle differences to give indication of incorrect phase relationship will depend on network situations.

NOTE 3 A *phase comparator* may not indicate properly in the presence of large harmonic and/or amplitude distortion (e.g. HV a.c./d.c. converters, non-linear loads, etc.). Relevant data, acceptable limits and performance requirements are under consideration.

#### 4.2.1.2 Settings

The user shall not have access to the settings of the *indicator*.

A selector for different *nominal voltages* or different *nominal voltage* ranges is allowed, but for each position of the selector the user shall not have access to any settings.

On each unit of a wireless *phase comparator* there could be an accessible selector for setting a multi-channel connecting system (e.g.: radio communication).

#### 4.2.1.3 Continuous indication

Once the *phase comparator* gives *clear indication* it shall continue to indicate as long as it is in direct contact with the live part.

#### 4.2.1.4 Influence of interference fields

The presence of an *interference field* (adjacent live or earthed parts) shall not affect the indication when the *phase comparator* is used in accordance with the instructions for use.

NOTE The indication may not be reliable in the vicinity of large conductive parts that create equipotential zones.

#### 4.2.1.5 Special marking in the case of limited use

In the case of a *phase comparator* that does not fulfil anyone of the tests of 5.2.2 or 5.2.5 when using the test set-up of Figure 4, it shall have a marking “LU” for limited use.

#### 4.2.1.6 Electromagnetic compatibility (EMC)

*Phase comparators* shall comply with the requirements of class A for portable equipment according to IEC 61326-1.

NOTE In some countries additional requirements may be added to fulfil EMC regulations.

#### 4.2.2 Distance range

Wireless operating *phase comparators* shall communicate properly within the limits of the distance range in free space (between the various units of the whole device) specified by the manufacturer in the instructions for use (see Annex A).

There are no radio communication requirements in this standard. Where relevant, the *phase comparator* should conform to the national radio communication regulations.

#### 4.2.3 Clear perceptibility

##### 4.2.3.1 Visual indication

The *phase comparator* shall give a clear visual indication to the user when in operating position and under normal light conditions.

When two or more visual *active signals* are used, the indication shall not rely solely on light of different colours for perceptibility. Additional characteristics, such as physical separation of the light sources, distinctive form of the light signals, or flashing light shall be used.

##### 4.2.3.2 Audible indication (where relevant)

The *phase comparator* shall give a clear audible indication to the user when in the operating position and under normal noise conditions.

When two audible *active signals* are used, the indication shall not rely solely on sounds of different sound pressure level for perceptibility. Additional characteristics, such as tone or intermittence of the audible signals shall be used.

#### 4.2.4 Temperature and humidity dependence of the indication

There are three categories of *phase comparators* according to the climatic conditions of operation: cold (C), normal (N) and warm (W). The *phase comparator* shall operate correctly in the temperature range of its climatic category, according to Table 1.

**Table 1 – Climatic condition ranges**

Climatic condition ranges (operation and storage)		
Climatic category	Temperature °C	Humidity %
Cold (C)	–40 to +55	20 to 96
Normal (N)	–25 to +55	20 to 96
Warm (W)	–5 to +70	12 to 96

#### 4.2.5 Frequency dependence

##### 4.2.5.1 General

At a given time the value of the frequency is considered to be the same all over a network. Then the following requirements apply when both parts to be compared have the same frequency.

##### 4.2.5.2 Tolerance of nominal frequency

The *phase comparator* shall operate correctly at frequencies within a tolerance of at least  $\pm 0,2$  % of the nominal frequency.

A *phase comparator* with two nominal frequencies shall operate correctly for each nominal frequency within a tolerance of at least  $\pm 0,2$  %.

##### 4.2.5.3 Frequency shift of single-pole phase comparator

Single-pole *phase comparators* shall operate correctly with variations of frequency up to 1 MHz/s during the *memory holding time* declared by the manufacturer after the indication "memory ready" appears.

The indication of a single-pole *phase comparator* shall not be assessed as "correct phase relationship" with variations of frequency above 10 MHz/s during at least 5 s after the indication "memory ready" appears.

The *memory holding time* shall be at least 5 s.

#### 4.2.6 Response time

The *response time* of the *phase comparator* shall not be more than 1 s. In situations where the *response time* is above 1 s the phase comparator shall give a visual and/or audible indication that data processing is still running.

#### 4.2.7 Power source dependability

The *phase comparator* with a built-in power source shall give a *clear indication* until a non-readiness signal appears or the device is automatically shut off, as mentioned in the instructions for use.

#### 4.2.8 Testing element

The *testing element*, whether built-in or separate, shall be capable of testing all the electrical circuits, the *wireless connecting system*, the energy source and the functioning of the indication. When all circuits cannot be tested, any limitation shall be clearly stated in the instructions for use. These circuits shall be of high reliability construction. When there is a built-in *testing element*, the *phase comparator* shall give an indication of "ready" or "not ready".

#### 4.2.9 Time rating

The *phase comparator* shall be able to perform during its specified time rating without failure and without giving incorrect indication when subjected to the maximum operating voltage.

The minimum time rating shall be:

- 5 min in the case of a *phase comparator* at a *nominal voltage* up to 36 kV;
- 15 min in the case of a *phase comparator* at a *nominal voltage* above 36 kV.

The manufacturer shall clearly state in the instructions for use the maximum time rating for the user.

### 4.3 Electrical requirements

#### 4.3.1 Insulating material

The insulating materials shall be adequately rated (nature of material, dimensions) for the *nominal voltage* (or the maximum *nominal voltage* of the voltage range) of the *phase comparator*.

When tubes of insulating material with circular cross-section are used in the design of *phase comparators*, they should meet the requirements of IEC 60855-1 or IEC 61235, otherwise they shall demonstrate appropriate insulating performance by fulfilling the test of 5.3.1.

For a *phase comparator* as a complete device the user shall be provided with adequate insulation by means of an *insulating element*.

NOTE For a *phase comparator* as a separate device, the selection of an appropriate adaptable *insulating stick* will provide the user with adequate insulation.

#### 4.3.2 Protection against bridging

Protection shall be such that the *phase comparator* cannot cause flashover or breakdown between live parts of an installation or between a live part of an installation and earth.

#### 4.3.3 Resistance against sparking

The *phase comparator* shall be so constructed that the *indicator* cannot be damaged or shut-off as a result of a low energy electric arc.

#### 4.3.4 Insulating element of phase comparator as a complete device

##### 4.3.4.1 Dielectric strength

The *insulating element* shall be rated so that no flashover or breakdown occurs in use.

##### 4.3.4.2 Leakage current

The *insulating element* of the *indoor type phase comparator* shall be so rated that leakage current shall be limited under dry conditions.

The *insulating element* of the *outdoor type phase comparator* shall be so rated that leakage current shall be limited under dry and wet conditions.

#### 4.3.5 Indicator casing

The *indicator* casing shall be rated so that no flashover or breakdown occurs in use.

## 4.4 Mechanical requirements

### 4.4.1 General

For a *phase comparator* as a complete device the user shall be provided with adequate distance by means of an *insulating element*.

NOTE For a *phase comparator* as a separate device, the selection of an appropriate *insulating stick* will provide the user with adequate distance.

### 4.4.2 Design

The *phase comparator* shall be designed to allow operation by one person.

The *phase comparator* as a complete device shall include the following elements as a minimum:

- handle, *hand guard*, *insulating element*, *indicator*, *limit mark* and *contact electrode* (see Figure 1).

The position of the *limit mark* may be on either side of the *indicator*.

The *phase comparator* as a separate device shall include the following elements as a minimum:

- *adaptor*, *indicator* and *contact electrode* (see Figure 1).

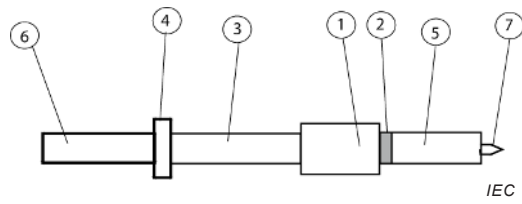

a) Example of a single-pole phase comparator as a complete device

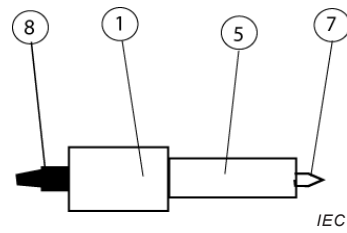

b) Example of a single-pole phase comparator as a separate device

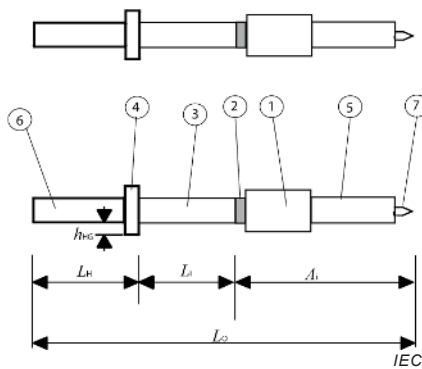

c) Example of a two-pole phase comparator with wireless connection as a complete device

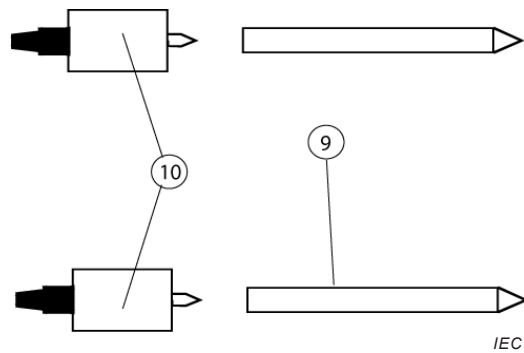

d) Example of a two-pole phase comparator with wireless connection as a separate device

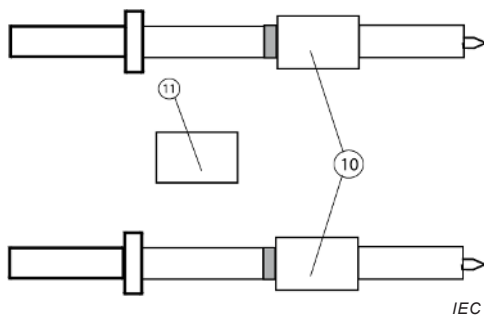

e) Example of a two-pole phase comparator with wireless connection and three communication units as a complete device

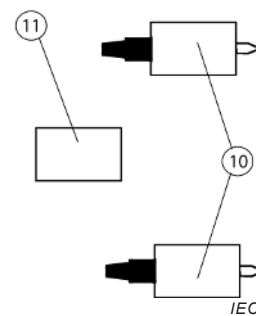

f) Example of a two-pole phase comparator with wireless connection and three communication units as a separate device

**Key**

- |   |  |          |  |
|---|--|----------|--|
| 1 | <i>indicator</i>                             | 9        | <i>contact electrode extension (accessory)</i> |
| 2 | <i>limit mark</i>                            | 10       | <i>two basic communications units</i>          |
| 3 | <i>insulating element</i>                    | 11       | <i>indicator unit</i>                          |
| 4 | <i>hand guard</i>                            | $h_{HG}$ | <i>height of hand guard</i>                    |
| 5 | <i>permanent contact electrode extension</i> | $L_H$    | <i>length of handle</i>                        |
| 6 | <i>handle</i>                                | $L_i$    | <i>length of insulating element</i>            |
| 7 | <i>contact electrode</i>                     | $L_O$    | <i>overall length of phase comparator</i>      |
| 8 | <i>adaptor (can be used as limit mark)</i>   | $A_i$    | <i>insertion depth</i>                         |

**Figure 1 – Illustration of different elements and different principles of functioning of phase comparators**

#### 4.4.3 Dimensions, construction

The minimum length of the *insulating element* of a *phase comparator* as a complete device shall be in accordance with Table 2.

**Table 2 – Minimum length of the insulating element ( $L_i$ ) of a phase comparator as a complete device**

$U_r$ kV	$L_i$ mm
$1 < U_r \leq 7,2$	320
$7,2 < U_r \leq 12$	360
$12 < U_r \leq 17,5$	370
$17,5 < U_r \leq 24$	470
$24 < U_r \leq 36$	520
$36 < U_r \leq 72,5$	830
$72,5 < U_r \leq 123$	1 300
$123 < U_r \leq 170$	1 700
$170 < U_r \leq 245$	2 300

NOTE 1 The *nominal voltage*  $U_n$  is used when the parameters to be specified are related to the installation dimensioning or to the functional performance of the *phase comparator*, while the *rated voltage*  $U_r$  is used when insulation performance of the *phase comparator* is concerned.

NOTE 2 The  $L_i$  values of Table 2 correspond to the minimum distance in air (obtained from Tables 1 and 2 of IEC 61936-1:2010) plus an additional safety distance.

NOTE 3 The  $L_i$  values of Table 2 can be used as a guidance to determine the length of the *insulating stick* used with a *phase comparator* as a separate device. However, the length of the *insulating stick* for live working can be shortened for a *phase comparator* as a separate device taking into account the minimum approach distances or in accordance with national or regional regulations.

In the case of a *phase comparator* as a complete device and for  $L_i$  equal to or greater than 520 mm, conductive parts are allowed within the minimum length of the *insulating element* if they are completely externally insulated and are located immediately adjacent to the *limit mark* in one section of the *insulating element* not exceeding 200 mm (see Figure 2).

NOTE 4 The performance of the insulation covering the conductive parts is verified by the *protection against bridging* test of 5.3.2.

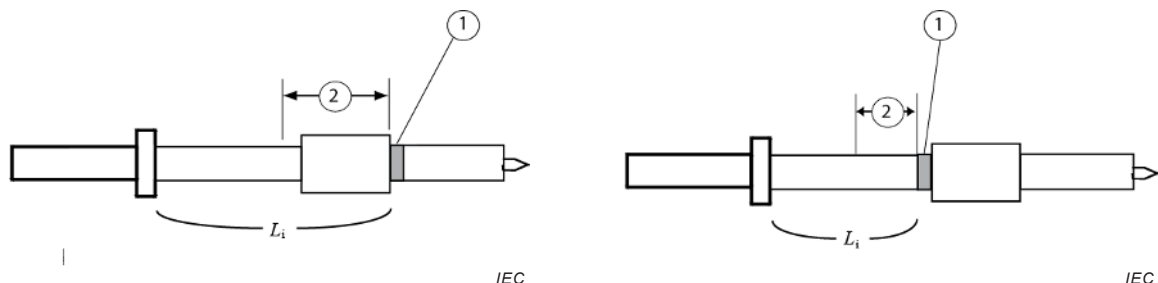

#### Key

- 1 *limit mark*
- 2 *section of the insulating element where conductive parts are allowed ( $\leq 200$  mm)*
- $L_i$  *minimum length of the insulating element*

**Figure 2 – Location of allowed conductive parts within the minimum length of the insulating element of a pole of a phase comparator as a complete device**



The *limit mark* shall be about 20 mm wide, permanent, and clearly recognizable by the user.

If there is no *limit mark* on a *phase comparator* as a separate device, the end of the *adaptor* can act as the *limit mark* (Figures 1b, 1d and 1f).

For a *phase comparator* as a complete device, the length of the handle ( $L_H$ ) shall be 115 mm as a minimum.

NOTE 5 A longer handle facilitates two-hand operation.

For a *phase comparator* as a complete device, the *hand guard* shall be permanently fixed and have a minimum height ( $h_{HG}$ ) of 20 mm.

In order to adapt the *phase comparator* to different uses, the *contact electrode* may readily be interchangeable with other types of *contact electrodes* depending on the type of installation to be compared and instructions for use.

When a *phase comparator* is intended to be disassembled by the user, the parts shall be clearly marked as belonging together.

#### 4.4.4 Grip force and deflection

The *phase comparator* shall be designed to facilitate reliable operation with reasonable physical effort by the user.

The *phase comparator* shall be designed to allow a safe approach toward the parts of the installation to be compared. The deflection of the pole(s), under its(their) own weight, shall be as low as possible.

NOTE In the case of a *phase comparator* as a separate device, the choice of an *insulating stick* may greatly influence the grip force and deflection.

#### 4.4.5 Vibration resistance

The *phase comparator* including the *indicator unit* (if any) shall be vibration resistant.

#### 4.4.6 Drop resistance

The *phase comparator* including the *indicator unit* (if any) shall be drop resistant.

#### 4.4.7 Shock resistance

The *phase comparator* including the *indicator unit* (if any) shall be shock resistant.

### 4.5 Marking

Each *phase comparator* shall have at least the following items of marking:

- *nominal voltage* and/or range of *nominal voltages*;
- nominal frequency or nominal frequencies;
- symbol for operational class (“A”, “B”, “C” or “D”);
- name or trade mark of the manufacturer;
- type reference, serial number;
- indication of type indoor or outdoor;
- symbol for climatic category or climatic categories (“C”, “N” or “W”);
- symbol “LU”, when relevant;
- year of production;

- symbol IEC 60417-5216 (2002-10) – Suitable for live working; double triangle (see Annex B);

NOTE The exact ratio of the height of the figure to the base of the triangle is 1,43. For the purposes of convenience, this ratio can be between the values of 1,4 and 1,5.

- number of the relevant IEC standard immediately adjacent to the double triangle symbol (“IEC 61481-1”).

To be marked with the number of this IEC standard, the product shall satisfy all the requirements specified herein.

With every *phase comparator* or with every batch of *phase comparators* to be delivered, the manufacturer shall provide information related to the number of the IEC standard with the year of publication.

In the case of a *phase comparator* with a built-in energy source, the type of power supply shall be indicated either on the *indicator* or inside the compartment designed to house it, and the polarity when required.

The marking shall be legible and permanent. The characters shall be at least 3 mm high. The marking shall not impair the quality of the *phase comparator*.

#### **4.6 Instructions for use**

The manufacturer shall provide written instructions for use with each *phase comparator* covered by this standard.

The instructions for use shall include as a minimum the information of Annex A.

These instructions shall be prepared in accordance with the general provisions of IEC 61477.

#### **4.7 Requirements in the case of reasonably foreseeable misuse during live working**

##### **4.7.1 Voltage selection**

In the case of incorrect position of the voltage selector, if any, the *phase comparator* shall give no incorrect indication of phase relationship.

##### **4.7.2 Frequency selection**

In the case of incorrect position of the frequency selector, if any, the *phase comparator* shall give no indication of phase relationship.

##### **4.7.3 Channel selection for wireless connection**

In the case of incorrect setting of the channel selectors, if any, the *phase comparator* shall give no indication of a phase relationship.

## **5 Tests**

### **5.1 General**

#### **5.1.1 Testing provisions**

This standard provides testing provisions to demonstrate compliance of the product to the requirements of Clause 4. These provisions are primarily intended to be used as type tests for the validation of the design input. Where relevant, alternative means (calculation, examination, tests, etc.), are specified within the test subclauses for *phase comparators* having completed the production phase.

Tests shall be performed on a *phase comparator* which has been completely assembled, in accordance with instructions for use. Unless otherwise specified, for a *phase comparator* as separate device, the tests shall be performed with each pole equipped with an *insulating stick* complying with 4.3.1, 4.4.1 and 4.4.3.

NOTE It is essential that the tests are done by a competent test facility.

### 5.1.2 Atmospheric conditions

Except when otherwise stated, tests are carried out under the following standard atmospheric conditions of IEC 60068-1 for measurements and tests:

- ambient temperature 15 °C to 35 °C;
- relative humidity 25 % to 75 %;
- atmospheric pressure 86 kPa to 106 kPa.

For type tests, the *phase comparator* shall be subjected to these conditions for at least 4 h before being submitted to the group of tests.

### 5.1.3 Tests under wet conditions

Before the electrical tests, each *phase comparator* shall be cleaned with isopropanol ( $\text{CH}_3\text{-CH(OH)-CH}_3$ ) and then dried in air for 15 min.

NOTE It is not part of this standard to ensure that the relevant legislation and safety requirements for the use of this chemical are complied with in their entirety.

The test under wet conditions shall be conducted in accordance with 4.4.1 of IEC 60060-1:2010 (wet test procedure), with the following exception: the openings in the collecting vessel designed to measure the wetting rate shall be less than, or equal to, the horizontal cross-section of the *indicator*.

### 5.1.4 Type test

#### 5.1.4.1 Type test on basic configuration

The type test shall be performed on three complete *phase comparators* representative of the production and on three test pieces of each material providing high-voltage insulation except for 5.2.4 which is performed on only one *phase comparator*. If more than one *phase comparator* or test piece does not pass, the test has failed. If only one *phase comparator* or test piece fails, the entire sequence for the type test shall be repeated on three other *phase comparators* or test pieces. If any one of these three new *phase comparators* or test pieces does not pass, the type test is considered to have failed.

NOTE In the particular case of 5.2.4, if the *phase comparator* does not pass, the type test is considered to have failed.

Type tests shall be performed in the sequence defined in Annex C.

#### 5.1.4.2 Type test on additional contact electrodes and accessories

The use of different *contact electrodes* or *accessories* or combination of *accessories* may affect the performance of the *phase comparator*.

When several *contact electrode extensions* or several *contact electrodes* are provided, the following tests shall be performed with each *contact electrode extension*, each *contact electrode* and each combination of them:

- vibration resistance (see 5.4.3),
- drop resistance (see 5.4.4),

- *clear indication* (see 5.2.2),
- influence of electric *interference fields* (see 5.2.5),
- *protection against bridging* for *indoor/outdoor type phase comparator* (see 5.3.2),
- *protection against bridging* for *outdoor type phase comparator* (see 5.3.3),
- spark resistance (see 5.3.4) and
- distance range (see 5.2.3).

These type tests can be done

- with the same set of *phase comparators*, these being equipped successively with the different *accessories* or combination of *accessories*, or
- with different sets of *phase comparators*, each set being equipped with a different *accessory* or combination of *accessories*.

In the case of different sets of *phase comparators*, for each set if more than one *phase comparator* does not pass the test the set has failed. For each set if only one *phase comparator* fails, the entire sequence for the relevant type test (see 5.1.4.1) shall be repeated on a new set of three *phase comparators*. If any one of these three new *phase comparators* fails, the type test of this configuration is considered to have failed.

#### 5.1.4.3 Type test of a family of phase comparators

In the case of *phase comparators* of the same family the following applies.

- The type tests shall be performed at the lowest and at the highest *nominal voltages* delimiting the *family of phase comparators*. Within the limits of the family, bridging tests (5.3.2 and 5.3.3) shall be performed for each distance  $d_1$  of Table 7 under the highest voltage of each voltage range. Mechanical tests shall be done only once covering the worst conditions.
- The test for *clear indication* (see 5.2.2) shall be carried out at each *nominal voltage* or each *nominal voltage* range. Each time the test set-up changes within the range of the *nominal voltages* of the *phase comparator* the corresponding test shall be carried out.

#### 5.1.5 Test methods

Tests shall be carried out using an a.c. power source in accordance with the requirements given in IEC 60060-1.

The maximum test voltage value shall be reached within 10 s to 20 s.

All types of *phase comparators* (indoor and outdoor) shall be submitted to the tests in dry conditions.

Unless otherwise specified,

- a tolerance of  $\pm 3\%$  is allowed for all required values,
- dielectric tests shall be carried out at a frequency of 50 Hz or 60 Hz,
- additional tests applicable to *outdoor type phase comparators* shall be performed under wet conditions.

No correction factor due to climatic conditions shall be applied to test voltages.

## 5.2 Function tests

### 5.2.1 Description of the test set-up and general pass criteria

The tests shall be performed using a test set-up made of two ball-and-ring arrangements as shown in Figure 3 and Figure 4 with the dimensions specified in Table 3. The distinction

between Figure 3 and Figure 4 is the relative position of the ball electrode and its associated ring electrode. Both test set-ups permit to simulate various installation configurations.

It is important to limit the influence of the elements that provide the mechanical support and the electrical connections to the test set-up on the electric field configuration around the test electrodes.

For this purpose, around each test electrode (ball and ring), a spherical zone is defined in which only the elements illustrated in Figure 3 or 4 are permitted.

For each ball electrode, the supporting element shall permit connection to the voltage source. The electrical connection shall consist of a cable with a conductor section of  $2 \text{ mm}^2$  to  $5 \text{ mm}^2$  inserted in an insulating tube to provide mechanical support and additional electrical insulation.

For each ring electrode, the element(s) providing mechanical support and the ones providing electrical connection shall be out of the spherical zone except for its fixing or connecting device(s) to the ring which shall be as small as possible.

The floor of the test room shall be conductive or be laid out with conductive matting and connected to earth. The tests shall be conducted in a room which is free from unwanted foreign *interference fields*. No objects, except the insulating supporting element of the test set-up, shall be situated between the test set-up and the floor (ground) within a distance  $H$  and within a distance  $W$  in any direction from the test set-up according to Table 3.

The pole(s) of the *phase comparator* shall be fixed by means of an insulating support at the handle, in such a manner that its *contact electrode* touches the ball electrode, and the *indicator* is approximately concentrically located in relation to the associated ring electrode (in the horizontal axis) (see Figure 5). A suitable means shall be used for ensuring a good electrical connection as well as a mechanical pressure between the *contact electrode* of the *phase comparator* and the ball electrode without disturbing the local electric field. An example of such means is illustrated in Figure 6a. Likewise it is possible to modify the ball electrode without disturbing the local electric field. An example of such a modified ball electrode is illustrated in Figure 6b.

To be in accordance with this standard without any restriction, the *phase comparator* shall fulfil the tests performed with the test arrangements of Figures 3 and 4.

When the *phase comparator* without any *accessory* only fulfils the tests performed with the test arrangement of Figure 3, it shall be marked with “LU” (limited use).

Dimensions in millimetres

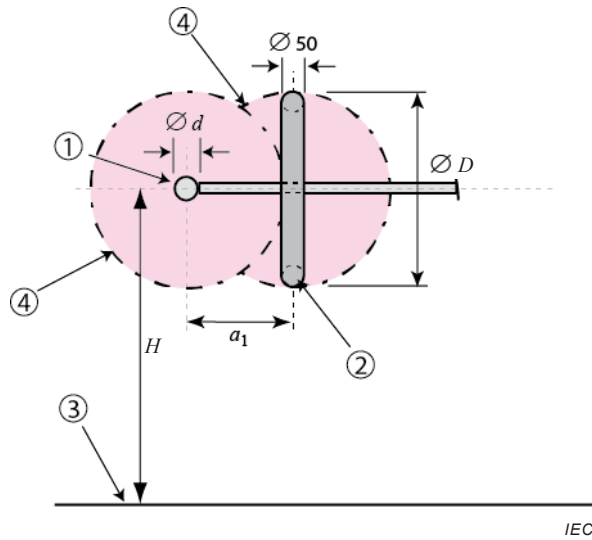

a) Side view

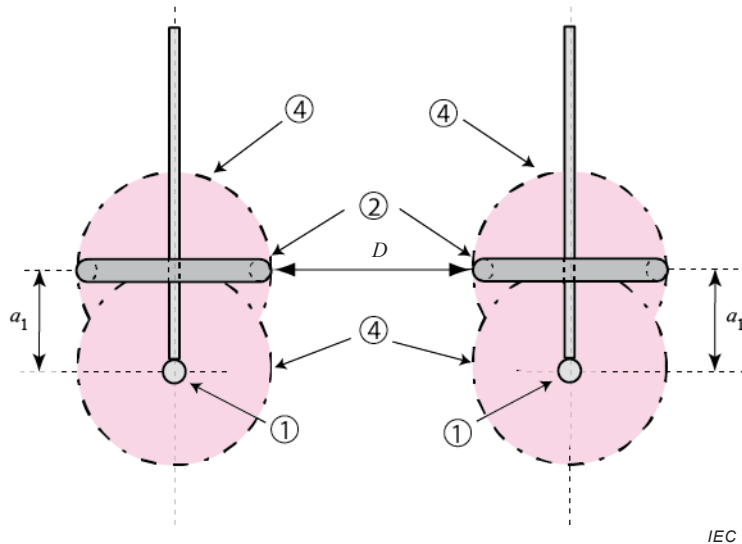

b) Top view

**Key**

- |   |   |
|---|---|
| 1 ball electrodes (B1 and B2) of $\varnothing d$ diameter with their supporting element | $a_1$ electrode separation distance                 |
| 2 ring electrodes (R1 and R2) of $\varnothing D$ diameter                               | $D$ distance between the two ring electrodes        |
| 3 ground  | $H$ distance between the test set-up and the ground |
| 4 spherical zone of $\varnothing D$ diameter around each test electrode                 |   |

NOTE Diameter “ $D$ ” and distance “ $D$ ” are of the same value.

**Figure 3 – Test set-up for clear indication with the ball electrode in front of its ring electrode**

Dimensions in millimetres

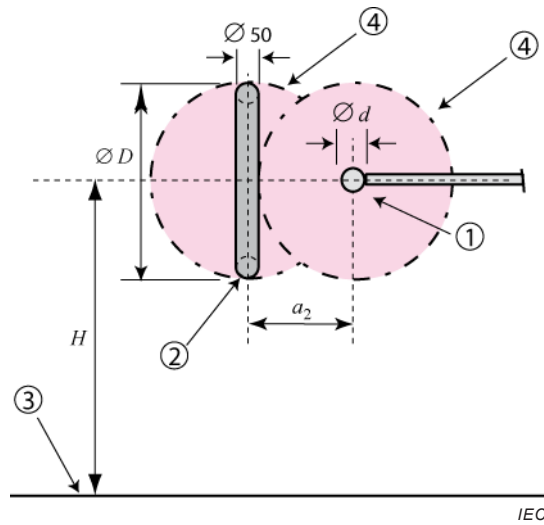

a) Side view

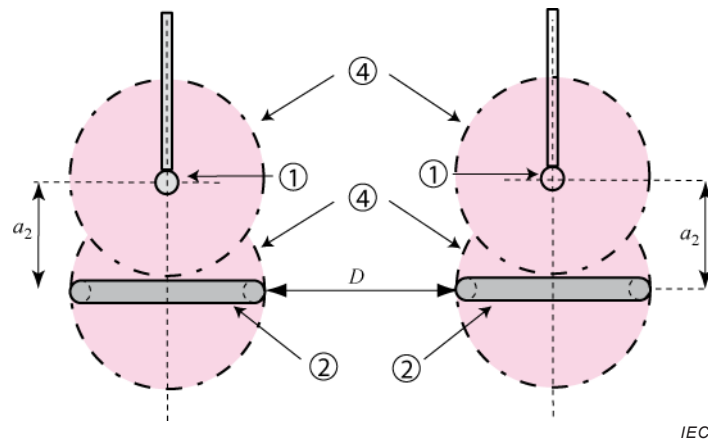

b) Top view

**Key**

- |   |   |
|---|---|
| 1 ball electrodes (B1 and B2) with $\varnothing d$ diameter with their supporting element | $a_2$ electrode separation distance                 |
| 2 ring electrodes (R1 and R2) with $\varnothing D$ diameter                               | $D$ distance between the two ring electrodes        |
| 3 ground  | $H$ distance between the test set-up and the ground |
| 4 spherical zone of $\varnothing D$ diameter around each test electrode                   |   |

NOTE Diameter “ $D$ ” and distance “ $D$ ” are of the same value.

**Figure 4 – Test set-up for clear indication with the ball electrode behind its ring electrode**

Table 3 – Dimensioning of the ball and ring test set-up

$U_n$	Electrode separation distance when the ball is in front of the ring $a_1$	Electrode separation distance when the ball is behind the ring $a_2$	$H$	Diameter " $\varnothing D$ " and distance " $D$ "	$d$	$W$ (3 times $D$ ) Clearance of the complete test set-up from any foreign objects
kV	mm	mm	mm	mm	mm	mm
$1 < U_n \leq 12$ $12 < U_n \leq 24$ $24 < U_n \leq 52$	300	100 270 430	1 500	550	$\varnothing 60$	$> 1\,650$
$52 < U_n \leq 170$ $170 < U_n \leq 245$	1 000	650 850	2 500	1 050	$\varnothing 100$	$> 3\,150$

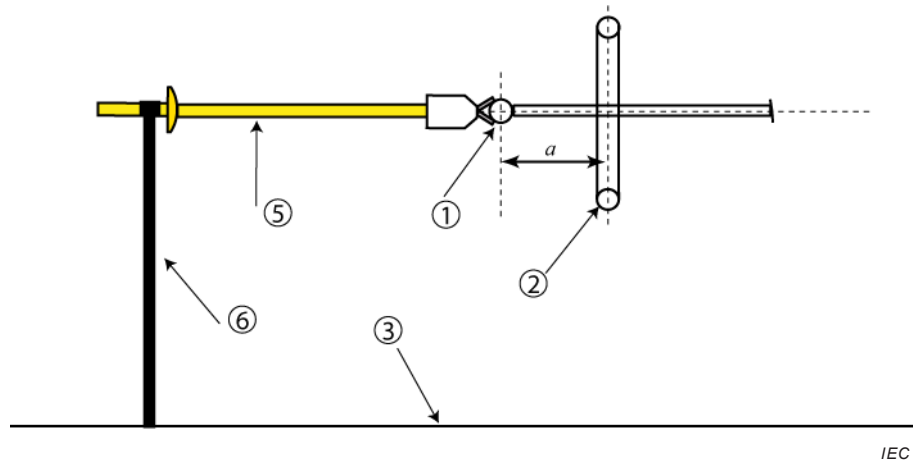

**Key**

- 1 ball electrode
- 2 ring electrode
- 3 ground
- 5 pole of the *phase comparator* (as a complete device or equipped with an *insulating stick*)
- 6 one insulating support for maintaining the pole horizontal to ground

**Figure 5 – Positioning of a pole of the phase comparator in relation to a ball and ring test arrangement**

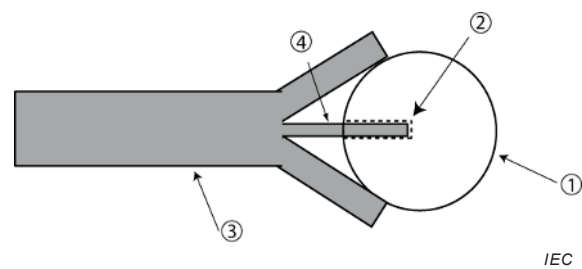

**a) Modification of a contact electrode used for testing**

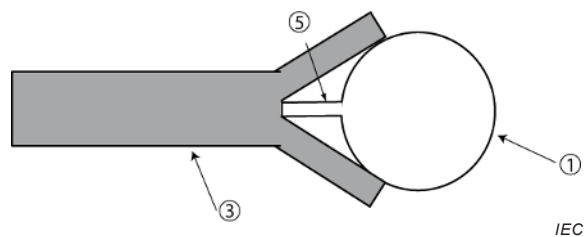

**b) Modification of the ball electrode**

**Key**

- 1 ball electrode
- 2 circular hole drilled in the ball electrode
- 3 Y shape *contact electrode*
- 4 cylindrical rod fixed to a Y shape *contact electrode* of a dimension to fit tightly into the hole of the ball electrode
- 5 cylindrical rod fixed to the ball electrode

**Figure 6 – Examples of suitable means for ensuring appropriate contact between a contact electrode and the ball electrode**

### 5.2.2 Clear indication

The description of the test set-up and the general pass criteria are those of 5.2.1.

For performing the *clear indication* tests, the two ring electrodes, designated as R1 and R2, shall be earthed.

In the case of a *phase comparator* with one *nominal voltage*  $U_n$  the test shall be performed at this *nominal voltage*.

In the case of a *phase comparator* with more than one *nominal voltage* the test shall be performed at every *nominal voltage*.

In the case of a *phase comparator* with one *nominal voltage* range the test shall be performed at the lowest ( $U_{n \min}$ ) and the highest ( $U_{n \max}$ ) value of the *nominal voltage* range.

In the case of a *phase comparator* with more than one *nominal voltage* range the test shall be performed at the lowest and the highest value of each *nominal voltage* range.

Each pole of the two-pole *phase comparator* shall be connected to one of the two ball electrodes of the test set-up. In the case of a single-pole *phase comparator*, the *contact electrode* shall touch successively the two ball electrodes according to the instructions for use.

For test series 1 and 2, the test electrodes shall have a voltage and phase relationship according to the relevant part of Table 4.

The test shall be considered as passed if the indication "incorrect phase relationship" does not appear or the indication "correct phase relationship" appears according to the type of indication of the *phase comparator*.

For test series 3 and 4, the test electrodes shall have a voltage and phase relationship according to the relevant part of Table 4.

The test shall be considered as passed if the indication "incorrect phase relationship" appears.

Table 4 – Test series and conditions for clear indication

Test series	Test voltage on the two ball-and-ring electrode arrangements (B1-R1 and B2-R2)				Required indication according to the type of indication	
	B1	R1	B2	R2	“Incorrect phase relationship”	“Correct phase relationship”
1	$0,45 U_{n \min}$	earth	$0,45 U_{n \min} 10^\circ \text{ a}$	earth	no	yes
2	$0,63 U_{n \max}$	earth	$0,63 U_{n \max} 10^\circ \text{ b}$	earth	no	yes
3	$0,45 U_{n \min}$	earth	$0,45 U_{n \min} 30^\circ \text{ a c}$	earth	yes	no
4	$0,63 U_{n \max}$	earth	$0,63 U_{n \max} 30^\circ \text{ b c}$	earth	yes	no

a  $0,45 U_n$  corresponds to  $0,78 U_n / \sqrt{3}$ .

b  $0,63 U_n$  corresponds to  $1,1 U_n / \sqrt{3}$ .

c A phase difference according to the operational class of the *phase comparator* (see 4.2.1) shall be adjusted. In the table, operational class A is used as an example.

### 5.2.3 Distance range for two-pole phase comparators with wireless connection

With all various communication units of the whole *phase comparator* separated each one from the other in free space by the maximum distance declared by the manufacturer, the communication between all these units shall be activated.

The test shall be considered as passed if all various units communicate properly according to the instruction for use.

### 5.2.4 Electromagnetic compatibility (EMC)

#### 5.2.4.1 Type test

The *phase comparator* shall be submitted to and shall fulfil the relevant tests of IEC 61326-1 for:

- immunity requirements for portable equipment powered by battery or from the circuit being measured with the following test parameters:

Description	Port	Test	Parameters
Electrostatic discharge (ESD)	Enclosure	IEC 61000-4-2	4 kV/8 kV (contact/air)
RF electromagnetic field immunity	Enclosure	IEC 61000-4-3	3 V/m for 80 MHz to 1 GHz (level 2) 3 V/m for 1,4 GHz to 2 GHz (level 2) 1 V/m for 2 GHz to 2,7 GHz
Power frequency magnetic field	Enclosure	IEC 61000-4-8	Not applicable

NOTE 1 Level 2 corresponds to a moderate electromagnetic radiation environment. This happens in presence of Global System for Mobile Communications (GSM), for example fixed transceivers, like microwave antenna for cell phones, installed in transmission structures or substations.

NOTE 2 *Phase comparators* of capacitive type are magnetically non sensitive devices.

With the following performance criteria for all the EMC tests:

Function	Criteria
Functioning of <i>phase comparator</i>	B
Data communication (if any)	B
Functioning of the <i>testing element</i>	B

- emission limit requirements for equipment intended for use in industrial locations with the following test parameters:

Description	Port	Test	Parameters
Radio disturbances characteristics	Enclosure	CISPR 11	Class A

The *phase comparator* shall be configured in a mode that represents normal working conditions according to the instructions for use.

The test shall be considered as passed if the relevant indications are not affected.

#### 5.2.4.2 Alternative means for phase comparators having completed the production phase

After completing the production phase, it is not practical to perform EMC tests for checking the conformity to the relevant requirements. Nevertheless, the manufacturer shall prove that it has followed the same documented assembly procedure as per the type tested device.

## **5.2.5 Influence of electric interference fields**

### **5.2.5.1 General**

The description of the test set-up and the general pass criteria are those of 5.2.1.

The test consists of the test series and conditions given in Table 5.

**Table 5 – Test series and conditions for influence of electric interference fields**

Test series	Test voltage on the two ball-and-ring electrode arrangements (B1-R1 and B2-R2)				Required indication according to the type of indication	
	B1	R1	B2	R2	“Incorrect phase relationship”	“Correct phase relationship”
<b>Influence of in-phase interference electric field</b>						
1	0,45 $U_{n \text{ min}}$	0,45 $U_{n \text{ min}}$	0,45 $U_{n \text{ min}}$ 10°	earth	no	yes
2	0,63 $U_{n \text{ max}}$	0,63 $U_{n \text{ max}}$	0,63 $U_{n \text{ max}}$ 10°	earth	no	yes
3	0,45 $U_{n \text{ min}}$	0,45 $U_{n \text{ min}}$	0,45 $U_{n \text{ min}}$ 30° <sup>a</sup>	earth	yes	no
4	0,63 $U_{n \text{ max}}$	0,63 $U_{n \text{ max}}$	0,63 $U_{n \text{ max}}$ 30° <sup>a</sup>	earth	yes	no
<b>Influence of phase opposition interference electric field</b>						
1	0,63 $U_{n \text{ max}}$	earth	0,63 $U_{n \text{ max}}$ 10°	0,63 $U_{n \text{ max}}$	no	yes
2	0,63 $U_{n \text{ max}}$	earth	0,63 $U_{n \text{ max}}$ 30° <sup>a</sup>	0,63 $U_{n \text{ max}}$	yes	no

<sup>a</sup> A phase difference according to the operational class of the *phase comparator* (see 4.2.1) shall be adjusted. In the table, operational class A is used as an example.

### 5.2.5.2 Influence of in-phase interference field

The test shall be considered as passed if the required indication in the relevant test series of Table 5 appears.

### 5.2.5.3 Influence of phase opposition interference field

The test shall be considered as passed if the required indication in the relevant test series of Table 5 appears.

## 5.2.6 Clear perceptibility

### 5.2.6.1 Clear perceptibility of visual indication

#### 5.2.6.1.1 Type test

The test set-up is given in Figure 7. It applies to *indicators* located at the high voltage end of the pole(s). In the case of *phase comparators* with *indicator unit(s)*, the type test of 5.2.6.1.2 applies.

The intensity of the light striking an unpolished grey screen with a reflectivity index of 18 % and the signal source of the *indicator* shall be:

- a) 50 000 lux  $\pm$  10 % for an *outdoor type phase comparator* with standard light D<sub>55</sub> according to CIE 15 corresponding to a colour temperature of 5 500 K  $\pm$  10 %;
- b) 1 000 lux  $\pm$  10 % for an *indoor type phase comparator* with standard light A according to CIE 15 corresponding to a colour temperature of 3 200 K  $\pm$  10 %.

The pole containing the indication shall be positioned in direction of axis A – B and the signal source part shall be centred on the axis A – B in normal use, according to Figure 7a.

The indication "incorrect phase relationship" and/or "correct phase relationship" shall be caused several times at irregular intervals unknown to the observer by arranging the corresponding phase relation on the test electrode(s).

The test can be performed by energizing the *phase comparator* by any relevant means if the same results are achieved.

Three observers with average sight look towards the *phase comparator* through the 5 mm holes in the front plate (see Figure 7b). The minimum distance between the front plate and the screen shall be 1 500 mm.

The test shall be considered as passed if the indication(s) is(are) seen by the three observers through each hole.

Dimensions in millimetres

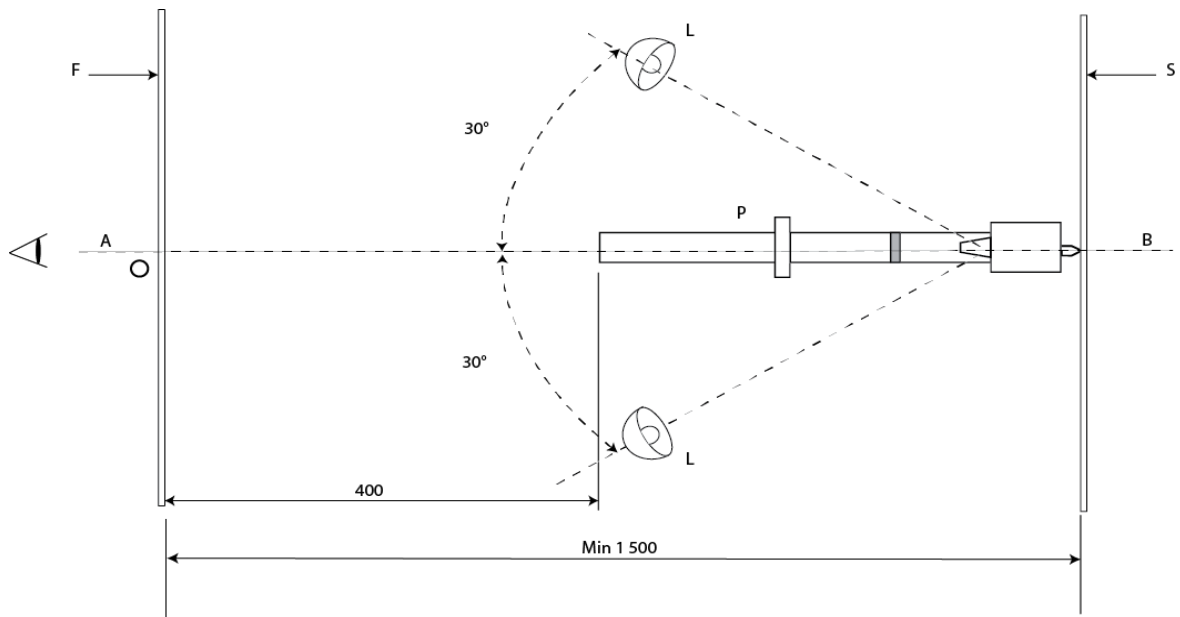

IEC

a) Top view

Dimensions in millimetres

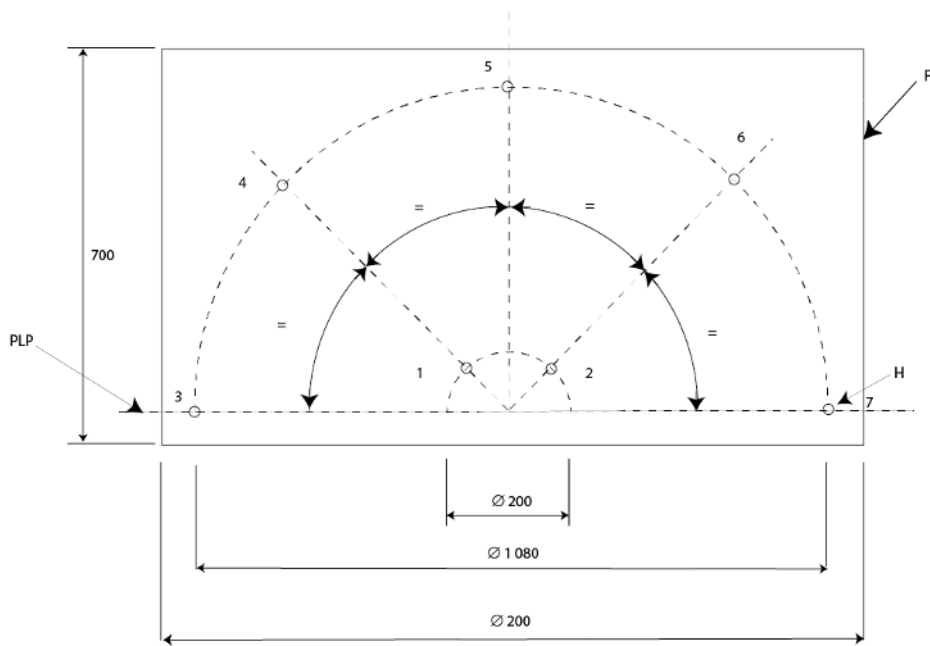

IEC

b) Front view of the front plate

**Key**

- |   |                                     |     |  |
|---|-------------------------------------|-----|--|
| P | pole of the <i>phase comparator</i> | S   | light-grey screen 1 000 × 1 000  |
| F | perforated front plate 3 mm thick   | H   | seven holes, 5 mm diameter   |
| L | light source                        | PLP | plane of the light sources and the pole of the <i>phase comparator</i> |

**Figure 7 – Test set-up for clear perceptibility of visual indication**



#### 5.2.6.1.2 Type test applicable to indicator units

The *indicator unit* of the *phase comparator* shall be placed in a room with low light reflection and so clamped that it can be turned around a horizontal axis at the display of the *indicator* and can be rotated around its longitudinal axis. At a distance of 150 mm behind the horizontal turning axis, a matt grey surface with identification colour IEC 60304 'grey' (for example, a painted wall or paper screen) with a diameter of at least 500 mm shall be arranged vertically in the room in such a way that its centre is behind the *indicator unit* of the *phase comparator*.

The *indicator unit* (test object) and the mat grey surface shall be lit by a diffuse white light from two halogen light sources, placed at least 1 m from the test object, in accordance with Figure 8. The arrangement shall be such that the light reflected from the matt grey surface to the *indicator* of the test object has an illumination of 3 500 lux.

At a distance of 750 mm from the test object, the forehead stop for the observer shall be arranged, as shown by item 5 in Figure 8.

The test object shall be rotated from the original vertical position to an angle of 15° and back to the original position, the display of the *indicator* being turned by rotation around the longitudinal axis of the test object by an angle of 10° to the right and to the left in order to identify the most unfavourable position of the indication.

The test shall be carried out consecutively by three observers with average sight. The observer places his forehead against the forehead stop. By an appropriate means, *active signals* shall be generated on the *indicator unit* with the display of the *indicator* in the most unfavourable position.

The indication "incorrect phase relationship" and/or "correct phase relationship" shall be caused several times at irregular intervals unknown to the observer by arranging the corresponding phase relation on the test electrode(s).

The test can be performed by energizing the *phase comparator* by any relevant means if the same results are achieved.

The test shall be considered as passed if each of the three observers clearly sees each visual indication.

Dimensions in millimetres

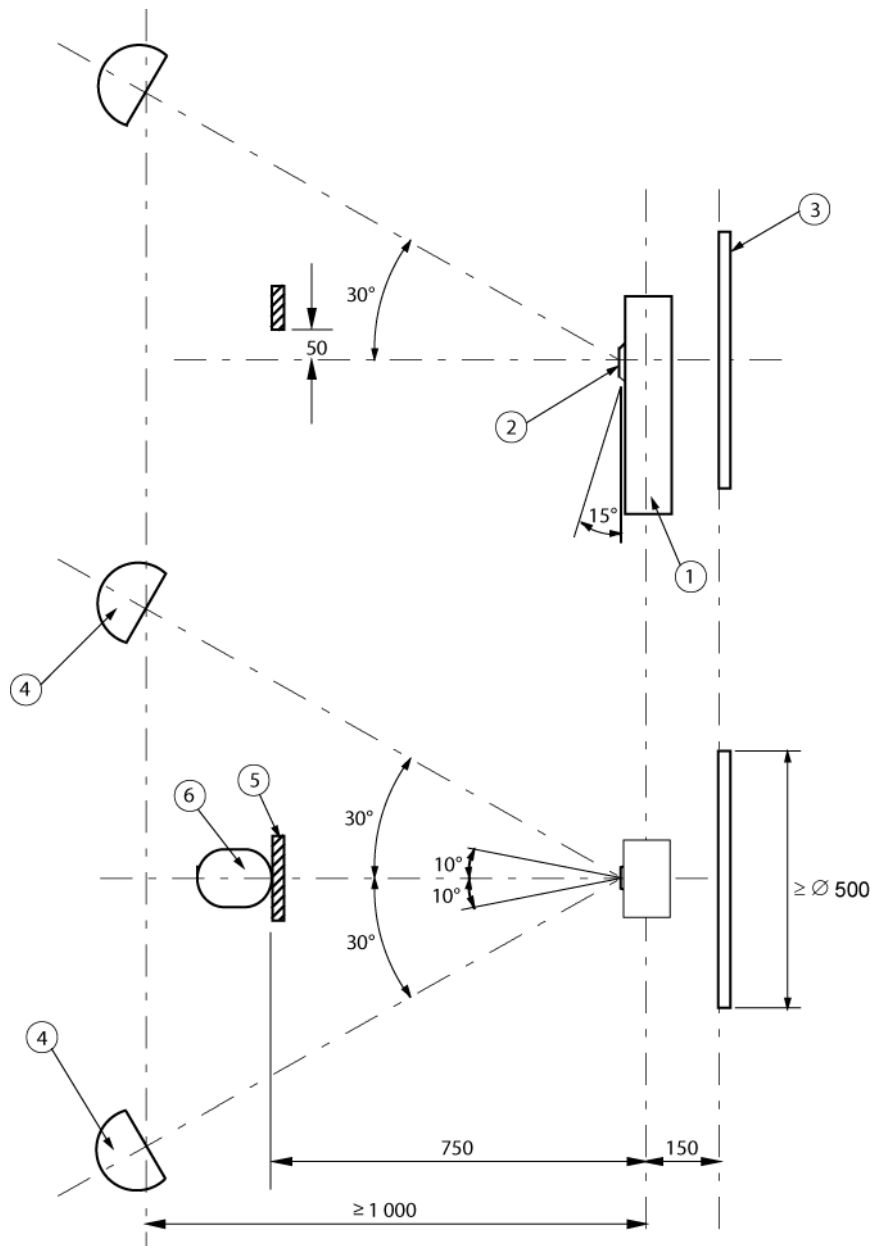

IEC

**Key**

- |   |                                      |   |               |
|---|--------------------------------------|---|---------------|
| 1 | test object                          | 4 | light source  |
| 2 | display of the <i>indicator unit</i> | 5 | forehead stop |
| 3 | area with matt grey surface          | 6 | observer      |

**Figure 8 – Test set-up for measurement of clear perceptibility of visual indication in the case of an indicator unit**

### 5.2.6.1.3 Alternative test for phase comparators having completed the production phase

The alternative test consists in comparing the perceptibility of the visual indication of a manufactured *phase comparator* to the one of a *phase comparator* which has passed successfully the type test according to 5.2.6.1.1 or 5.6.2.1.2 (reference *phase comparator*). The test shall be considered as passed if both perceptibilities are almost identical.

## 5.2.6.2 Clear perceptibility of audible indication (if available)

### 5.2.6.2.1 Type test

The test applies to *indicators* located at the high voltage end of the pole(s). In the case of *phase comparators* with *indicator unit(s)*, the type test of 5.2.6.2.2 applies.

The test shall be carried out in free-field over reflecting plane conditions, in an environment following the requirements of Annex A of ISO 3744:2010.

NOTE Such test conditions can be encountered in semi-anechoic rooms.

Averaged over the microphone positions, the level of the background noise shall be at least 6 dB(A) but preferably more than 15 dB(A) below the sound pressure level to be measured. If the difference between the sound pressure levels of the background noise and that emitted by the source is between 6 dB(A) and 15 dB(A), a correction shall be applied as described in 8.2.3 of ISO 3744:2010.

The instrumentation system, including the microphone and cable, shall meet the requirements for a class 1 instrument specified in IEC 61672-1. The filters used shall meet the requirements for a class 1 instrument specified in IEC 61260.

During each series of measurements, a sound calibrator with an accuracy of class 1 specified in IEC 60942 shall be applied to the microphone to verify the calibration of the entire instrument system.

The indication "incorrect phase relationship" and/or "correct phase relationship" shall be caused by arranging the corresponding phase relation on the test electrode(s).

The test can be performed by energizing the *phase comparator* by any relevant means if the same results are achieved.

The *phase comparator* shall be arranged as shown in Figure 9a, in such a manner that the sound axis of the *phase comparator* is parallel to the ground and at least 1,5 m away from any sound-reflecting surfaces.

A measuring plane shall be established, perpendicular to the sound axis according to Figure 9a. The distance of 400 mm can be increased by 200 mm if this will enable higher sound intensities to be measured.

The measurements shall be carried out for the indications "incorrect phase relationship" and/or "correct phase relationship", at each of the twelve microphone positions of Figure 9b. The sound pressure level shall be measured in each octave band of the frequency range 1 000 Hz to 4 000 Hz, with the A-weighting network.

The period of observation shall be at least 10 s for a continuous signal. For an intermittent signal, the integration time for the measurement shall be shorter than the signal duration.

The test shall be considered as passed, if for each microphone position, the sound pressure level, within at least one octave band of the frequency range of interest, is greater than

- 70 dB(A), (ref.: 20 µPa) for a *phase comparator* with continuous sound signal;
- 67 dB(A), (ref.: 20 µPa) for a *phase comparator* with intermittent sound signal.

Other higher values may be agreed between manufacturer and customer for specific usage in very noisy areas.

Dimensions in millimetres

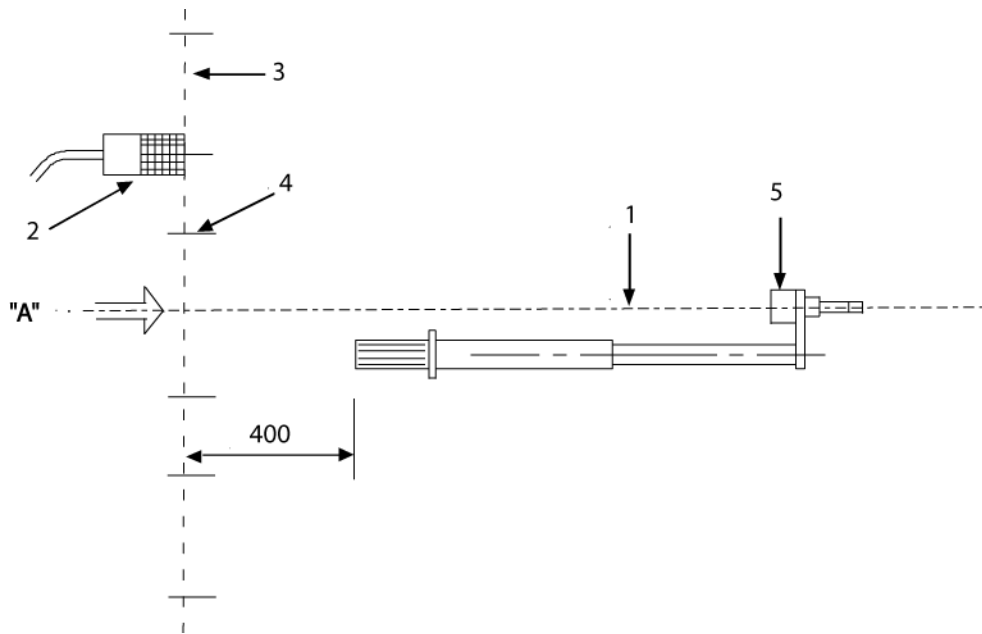

IEC

a) Side view

Dimensions in millimetres

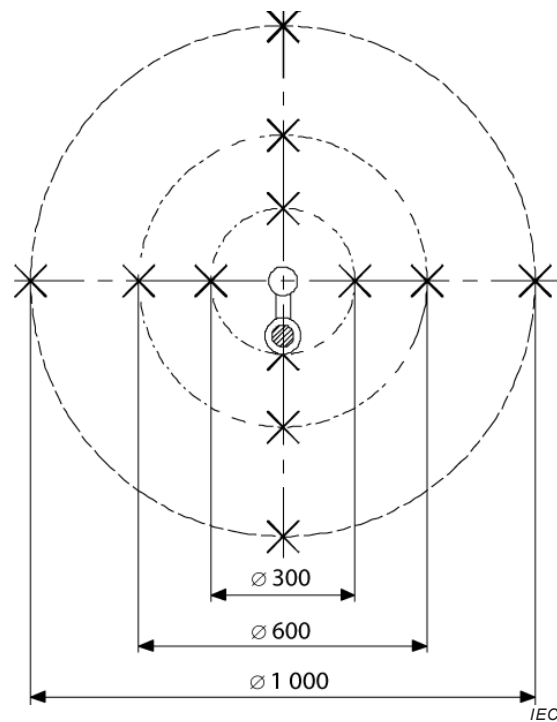

b) Front view from "A"

**Key**

- |   |                      |         |                                     |
|---|----------------------|---------|-------------------------------------|
| 1 | sound axis           | 4 and X | measuring points                    |
| 2 | measuring microphone | 5       | pole of the <i>phase comparator</i> |
| 3 | measuring plane      |         |                                     |

**Figure 9 – Test set-up for clear perceptibility of audible indication**

### 5.2.6.2.2 Type test applicable to indicator units

Sound pressure levels shall be measured according to the specifications of ISO 3744, in terms of the main requirements (grade 2 accuracy, measurement surface, microphone positions, background noise, etc.), except for the fact that the measurements are carried out in a free-field, without the reflecting plane referred to in ISO 3744.

The absorption coefficient of the environment shall be at least 0,9 at 700 Hz (see ISO 354). The measurement may be carried out in an anechoic room duly compliant with ISO 3745; in this case, the required absorption conditions are naturally fulfilled. In a semi-anechoic room or any other free-field over a reflecting plane environment in accordance with ISO 3744, the absorption of the reflecting plane can generally be obtained by covering this surface with a sound absorbing material approximately 20 cm thick and with a minimum surface area of 2,0 m × 2,0 m.

In addition, the background noise level of the room shall be at least 6 dB, and preferably more than 15 dB, below the sound pressure level to be measured within the frequency range of interest.

The instrumentation system, including the microphone and related cables, shall meet the requirements for a type 1 instrument as specified in IEC 61672-1 for sound level meters (required for continuous signal) or for integrating-averaging sound level meters (required for intermittent sounds). The filters used shall meet the requirements for a class 1 instrument specified in IEC 61260.

During each series of measurements, a sound calibrator with an accuracy of class 1 specified in IEC 60942 shall be applied to the microphone to verify the calibration of the entire instrument system.

The measuring surface shall be a hemisphere with a radius  $r = 1$  m and with ten microphone positions. The *indicator unit* (test object) shall be installed so that the sound transmitter is oriented towards point 10. The sound transmitter shall coincide with the centre of the coordinates system of the hemispherical measurement surface (see Figure 10a) and shall be at least 250 mm above the absorption surface on the floor (for example 250 mm above the sound absorbing material when the measurements are carried out in a modified semi-anechoic room).

The indication "incorrect phase relationship" and/or "correct phase relationship" shall be obtained by arranging the corresponding phase relation on the test electrode(s).

The test can be performed by energizing the *phase comparator* by any relevant means if the same results are achieved.

The sound pressure level shall be measured within the frequency range 1 000 Hz to 4 000 Hz, with the A-weighting network. Before starting measurements, it shall be checked that the *indicator* of the test object radiates predominantly within this frequency range. The A-weighted time-averaged sound pressure level shall be measured, for intermittent or continuous sound emission, at each microphone position (points 1 to 10 as described in Figure 10b). If the difference between the sound pressure level measured with the test object and the background noise level is between 6 dB and 15 dB, corrections shall be applied to the measurement values, in accordance with 8.2.3 of ISO 3744:2010. The A-weighted sound pressure levels are then averaged over the measurement surface (point 1 to 10) according to 8.2.2 of ISO 3744:2010.

Dimensions in millimetres

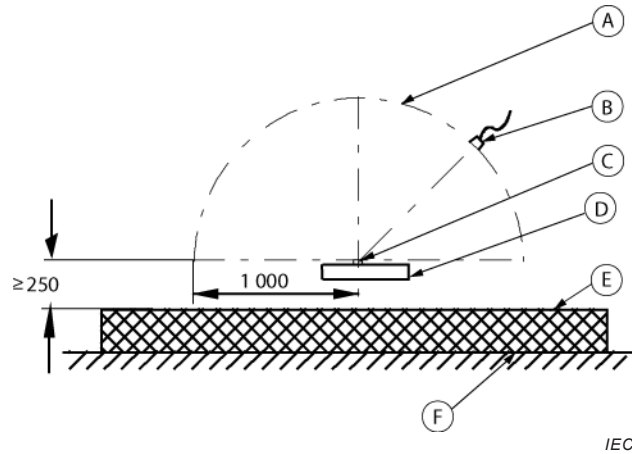

a) Positioning of the test object in the test set-up

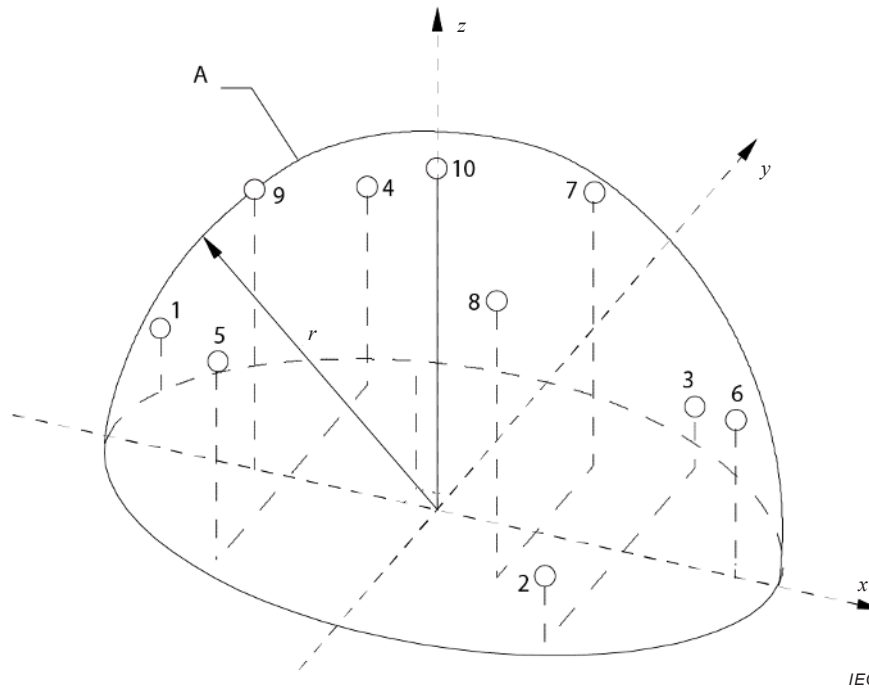

Microphone position	$x/r$	$y/r$	$z/r$	Microphone position	$x/r$	$y/r$	$z/r$
1	-0,99	0	0,15	6	0,89	0	0,45
2	0,50	-0,86	0,15	7	-0,33	0,57	0,75
3	0,50	0,86	0,15	8	-0,66	0	0,75
4	-0,45	0,77	0,45	9	0,33	-0,57	0,75
5	-0,45	-0,77	0,45	10	0	0	1,0

b) Key measurement points on the hemisphere

**Key**

- A hemisphere measurement surface
- B microphone
- C sound transmitter
- D indicator unit (test object)
- E sound absorbing material
- F mounting surface

**Figure 10 – Test set-up for measurement of clear perceptibility of audible indication in the case of indicator units**

The test shall be considered as passed if the values of the A-weighted time-averaged sound pressure levels, both for point 10 and for the average obtained for point 1 to 10, are equal to or exceed:

- 58,5 dB for continuous sound;
- 55,5 dB for intermittent sound.

#### **5.2.6.2.3 Alternative test for phase comparators having completed the production phase**

The alternative test consists in comparing the perceptibility of the audible indication of a manufactured *phase comparator* to the one of a *phase comparator* which has passed successfully the type test according to 5.2.6.2.1 or 5.2.6.2.2 (reference *phase comparator*). The test shall be considered as passed if both perceptibilities are almost identical.

### **5.2.7 Frequency dependence**

#### **5.2.7.1 Tolerance of nominal frequency**

##### **5.2.7.1.1 Type test**

The test consists in performing the tests for *clear indication* using the test set-up and the test procedure of 5.2.1 and 5.2.2.

For a *phase comparator* with one nominal frequency, the tests shall be performed at 99,8 % and 100,2 % of the nominal frequency on both ball test electrodes.

For a *phase comparator* with two nominal frequencies, the test shall be performed at 99,8 % and 100,2 % of each nominal frequency on both ball test electrodes.

The test shall be considered as passed if the sanctions of 5.2.2 are met.

##### **5.2.7.1.2 Alternative means for phase comparators having completed the production phase**

The manufacturer shall prove that it has followed the same documented assembly procedure as per the type tested device. The manufacturer shall document components that affect the performance under variations of the nominal frequency.

#### **5.2.7.2 Frequency shift for single-pole phase comparator**

##### **5.2.7.2.1 Type test**

The frequency generator shall have the following specification:

Where the distribution of the measurement error is known:

- frequency resolution: 0,25 mHz
- accuracy of the frequency measurement:  $\pm 0,000\ 5\ \%$  (5 ppm)

NOTE 1 This specification refers to the requirement for frequency shift of 1 mHz/s, with a ratio of 4/1.

Where the distribution of the measurement error is unknown:

- frequency resolution: 0,1 mHz
- accuracy of the frequency measurement:  $\pm 0,000\ 2\ \%$  (2 ppm)

NOTE 2 This specification refers to the requirement for frequency shift of 1 mHz/s, with a ratio of 10/1.

In the first test, the test procedure of 5.2.2 with the relevant test series 1 and 2 shall be applied with a linear frequency shift of 1 mHz/s during 5 s following the indication "memory ready", starting from the nominal frequency.

The test shall be considered as passed if the indication "incorrect phase relationship" does not appear or the indication "correct phase relationship" appears according to the type of indication of the *phase comparator*.

In the second test, the test procedure of 5.2.2 with the relevant test series 3 and 4 shall be applied with a linear frequency shift of 10 mHz/s during 5 s following the indication "memory ready", starting from the nominal frequency.

In the third test, the test procedure of 5.2.2 with the relevant test series 3 and 4, shall be applied with a linear frequency shift of 10 mHz/s during the maximum *memory holding time* declared by the manufacturer starting from the nominal frequency.

The two last tests shall be considered as passed if the indication "incorrect phase relationship" or "non-readiness" appears.

The test can be performed by energizing the *phase comparator* by any relevant means if the same results are achieved.

#### **5.2.7.2.2 Alternative means for single-pole phase comparators having completed the production phase**

The manufacturer shall prove that it has followed the same documented assembly procedure as per the type tested device. The manufacturer shall document components that affect the performance under frequency shift.

### **5.2.8 Response time**

#### **5.2.8.1 Type test**

According to the type of indication of the *phase comparator* two voltages according to Table 4 (test series 1 or test series 3) shall be applied to the ball test electrodes B1 and B2 (see Figure 3) to get a *clear indication* of the phase relationship.

The ring test electrodes R1 and R2 shall be earthed.

The *response time* of the two-pole *phase comparator* shall be measured after the second pole is brought into contact with electrode B2. For a single-pole *phase comparator*, it shall be moved from test electrode B1 to test electrode B2 after the indication "memory ready" appears.

The test shall be considered as passed if within 1 s after the moment when the relevant pole is brought into contact with electrode B2 the correct *clear indication* appears. Otherwise a *clear indication* that a data processing is still running shall appear before providing the indication of a phase relationship.

#### **5.2.8.2 Alternative means for phase comparators having completed the production phase**

The manufacturer shall prove that it has followed the same documented assembly procedure as per the type tested device. The manufacturer shall document components that affect the *response time*.



## 5.2.9 Power source dependability

### 5.2.9.1 Type test

The test shall be performed for a *phase comparator* with built-in power source only.

The *phase comparator* shall be connected to a voltage source with a test voltage and a phase difference that will make the indication “correct phase relationship” or “incorrect phase relationship” appear.

The *phase comparator* shall be removed from the voltage source and after switching off either automatically or manually it shall be switched on again after 2 min. Then it shall be connected to the voltage source again.

These procedures shall be repeated until

- an indication is given that the *phase comparator* is no longer operational, or
- the *phase comparator* is switched off automatically for that reason.

The test shall be considered as passed if one of the above-mentioned requirements is fulfilled and if, during each test step, the expected *active signal* appears.

The test duration may be reduced by using other methods that give the same result (for example, the use of an unloaded built-in power source with more energy than necessary for a good functioning or the use of an external power supply).

### 5.2.9.2 Alternative means for phase comparators having completed the production phase

The manufacturer shall prove that it has followed the same documented assembly procedure as per the type tested device. The manufacturer shall document components that affect the power source dependability.

## 5.2.10 Check of testing element

### 5.2.10.1 Type test

The *testing element* is activated according to the instructions for use.

A visual and, if provided, an audible signal shall appear according to the instructions for use. The *testing element* shall be activated three times, and a signal shall appear each time.

The electric circuit (and the flow chart if a software is used) shall be checked to verify that all circuits are tested, except those mentioned in the instructions for use.

### 5.2.10.2 Alternative test for phase comparators having completed the production phase

The test procedure of 5.2.10.1 shall be performed except for the check of the electric circuit.

## 5.2.11 Time rating of single-pole phase comparator

### 5.2.11.1 Type test

The *phase comparator* shall be connected to a voltage source with a test voltage of  $1,2 U_n$  and a phase difference that makes the indication “correct phase relationship” or “incorrect phase relationship” appear. The test voltage shall be applied to the *contact electrode* of the *phase comparator* for the maximum time rating declared by the manufacturer in the instructions for use.

The test shall be considered as passed if the expected indication is uninterrupted for all the test period.

#### **5.2.11.2 Alternative means for single-pole phase comparators having completed the production phase**

The manufacturer shall prove that it has followed the same documented assembly procedure as per the type tested device. The manufacturer shall document components that affect the time rating.

### **5.2.12 Time rating of two-pole wireless phase comparators**

#### **5.2.12.1 Type test**

For a *phase comparator* having a *nominal voltage* lower than or equal to 123 kV the test voltage shall be  $1,2 U_n$ . For a *phase comparator* having a *nominal voltage* higher than 123 kV the test voltage shall be  $1,2 U_n / \sqrt{3}$  but greater than 148 kV ( $\approx 1,2$  times 123 kV).

The *phase comparator* shall be connected to a voltage source with a test voltage defined above and a phase difference that makes the indication “correct phase relationship” or “incorrect phase relationship” appear. The test voltage shall be applied to the *contact electrodes* of the *phase comparator* for the maximum time rating declared by the manufacturer in the instructions for use.

The test shall be considered as passed if the communication between the different units, as well as the expected indication is uninterrupted for all the test period.

#### **5.2.12.2 Alternative means for two-pole wireless phase comparators having completed the production phase**

The manufacturer shall prove that it has followed the same documented assembly procedure as per the type tested device. The manufacturer shall document components that affect the time rating.

### **5.3 Dielectric tests**

#### **5.3.1 Insulating material for tubes and rods**

##### **5.3.1.1 Type test**

These tests shall only be performed for tubes and rods which are not covered by IEC 60855-1 or IEC 61235.

Insulating parts which are between 60 mm and 200 mm long shall be tested over their entire length. For longer lengths, test pieces of 200 mm shall be made. The ends of the test pieces shall not be sealed for the test.

A strip, approximately 0,5 mm thick and 10 mm wide, shall be removed over the entire length of the axis of each test piece. The test piece shall be conditioned in water having a maximum resistivity of  $100 \Omega \cdot \text{m}$  at a temperature of  $40^\circ\text{C} \pm 2 \text{ K}$  for 96 h.

At the end of this period, adhering water shall be wiped off. A 20 mm wide band electrode of conductive material shall be immediately applied on the exterior surface, at both ends of the test piece. After a drying period of  $15 \text{ min} \pm 1 \text{ min}$ , in a room at a temperature of  $23^\circ\text{C} \pm 3 \text{ K}$ , a test voltage of 1 kV/cm for 5 min shall be applied.

The test shall be considered as passed if the current is not greater than  $50 \mu\text{A rms}$  at any time during the last 4 min.

After removal of the test pieces, the current passing through the test set-up shall not exceed  $10 \mu\text{A rms}$  with the test voltage applied.

### 5.3.1.2 Alternative test or means for phase comparators having completed the production phase

(Under consideration)

### 5.3.2 Protection against bridging for indoor/outdoor type phase comparators

#### 5.3.2.1 General

Each pole of a *phase comparator* shall be tested.

The test is related to the part of a pole of a *phase comparator* located between the *limit mark* and the top of the *contact electrode*. If there is no *limit mark* on a *phase comparator* as a separate device, the end of the *adaptor* shall be regarded as the *limit mark* (Figure 1).

The test set-up used for the *protection against bridging* is given in Figure 11 while the type of test is given in Table 6.

**Table 6 – Type of test**

	$A_1+200 \text{ mm} > d_1$	$A_1+200 \text{ mm} \leq d_1$
Type of test	Surface stress and radial and surface stress	Surface stress

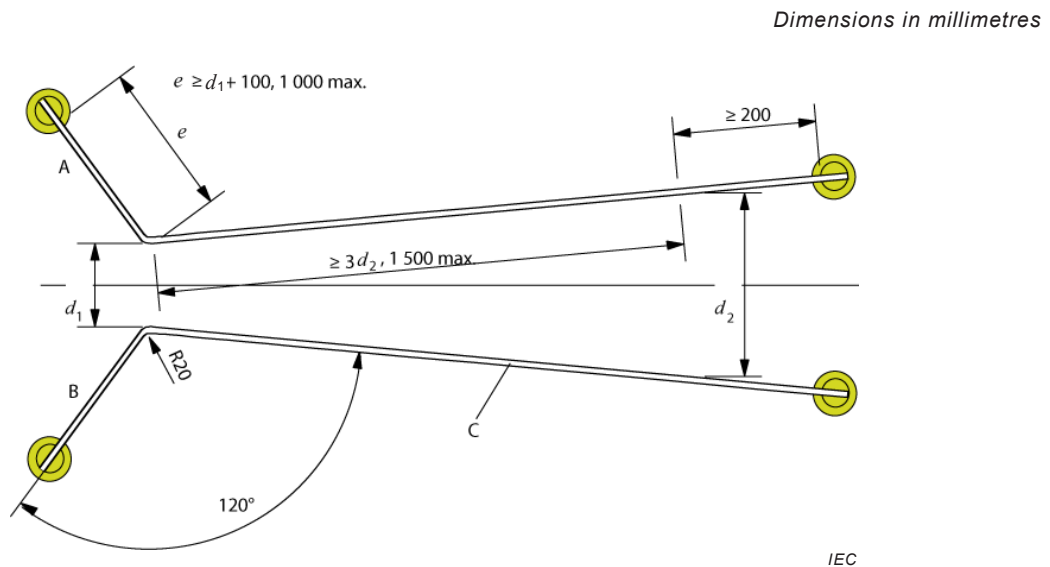

#### Key

- A bar A
- B bar B
- C bar section, for example copper or steel
- $e$  length of the short part of a bar

The bar section shall be  $60 \text{ mm} \times 10 \text{ mm}$  and the corners shall be rounded to a radius of  $1 \text{ mm}$ . The cut-off ends shall have the same curve as the bar.

**Figure 11 – Test arrangements and dimensions of the bars for protection against bridging**

The distance  $d_1$  between bar A and bar B shall be adjusted according to Table 7. The distance  $d_2$  of Figure 11, shall be calculated as follows:

$$d_2 = A_i + d_1 + 200 \text{ (all dimensions are in mm)}$$

where  $A_i$  is the *insertion depth* (Figure 1).

The test voltage shall be  $1,2 U_r$  for a *phase comparator* having a *nominal voltage* lower than or equal to 123 kV.

The test voltage shall be  $1,2 U_r / \sqrt{3}$  but shall be greater than 148 kV ( $\approx 1,2$  times 123 kV) for a *phase comparator* having a *nominal voltage* higher than 123 kV.

Bridging tests shall be performed within the limits of the voltage range of the *phase comparator* for each distance  $d_1$  at the highest voltage of each range given in Table 7.

**Table 7 – Distance  $d_1$  for the bridging test set-up**

$U_n$ kV	$d_1$ mm	
	Indoor	Outdoor
$U_n \leq 7,2$	50	150
$7,2 < U_n \leq 12$	60	150
$12 < U_n \leq 17,5$	85	180
$17,5 < U_n \leq 24$	115	215
$24 < U_n \leq 36$	180	325
$36 < U_n \leq 52$	240	520
$52 < U_n \leq 72,5$	330	700
$72,5 < U_n \leq 123$	650	1 100
$123 < U_n \leq 145$	1 100	1 100
$145 < U_n \leq 170$	1 350	1 350
$170 < U_n \leq 245$	1 850	1 850

The bars shall be electrically connected as shown in Figure 12. The ground clearance of bars shall be at least  $d_1$ .

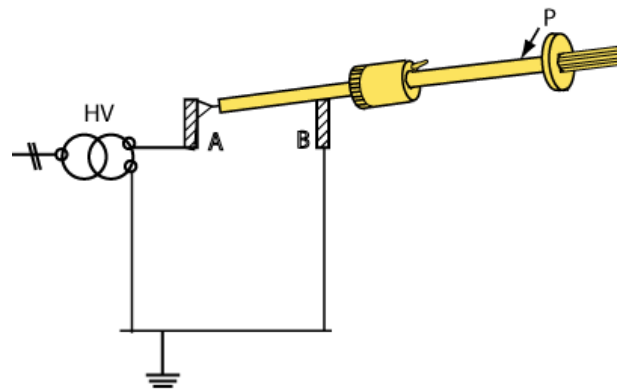

IEC

**Key**

- A bar A
- B bar B
- P pole of the *phase comparator*

**Figure 12 – Electrical connection of the bars****5.3.2.2 Surface stress test**

The top of the *contact electrode* of the pole to be tested shall be placed on bar A at the narrow point  $d_1$  (Figure 11) and the pole of the *phase comparator* shall be laid on bar B for 1 min. The pole of the *phase comparator* still staying at the narrow point is turned and pushed forward toward bar A, until the *limit mark* plus 200 mm reaches the bar A (Figure 13).

The test shall be considered as passed if no flashover or breakdown occurs.

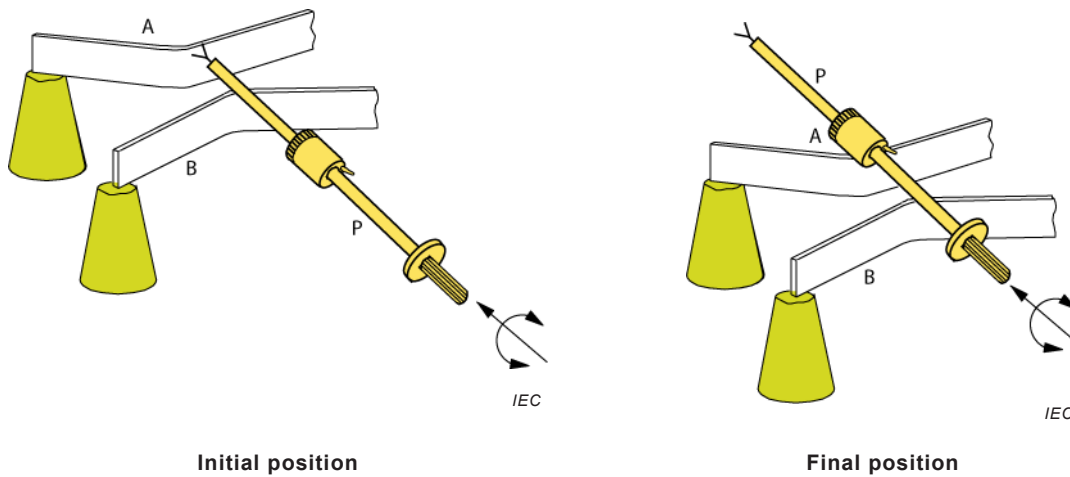
**Initial position****Final position****Key**

- A bar A
- B bar B
- P pole of the *phase comparator*

**Figure 13 – Surface stress test****5.3.2.3 Radial and surface stress test**

The top of the *contact electrode* of the pole to be tested shall be placed on bar A at the narrow point  $d_1$  and the pole of the *phase comparator* shall be laid on bar B. Then the pole of

the *phase comparator* is rolled along the bars, until the *limit mark* plus 200 mm reaches bar B (Figure 14) while the top of the *contact electrode* remains in contact with bar A.

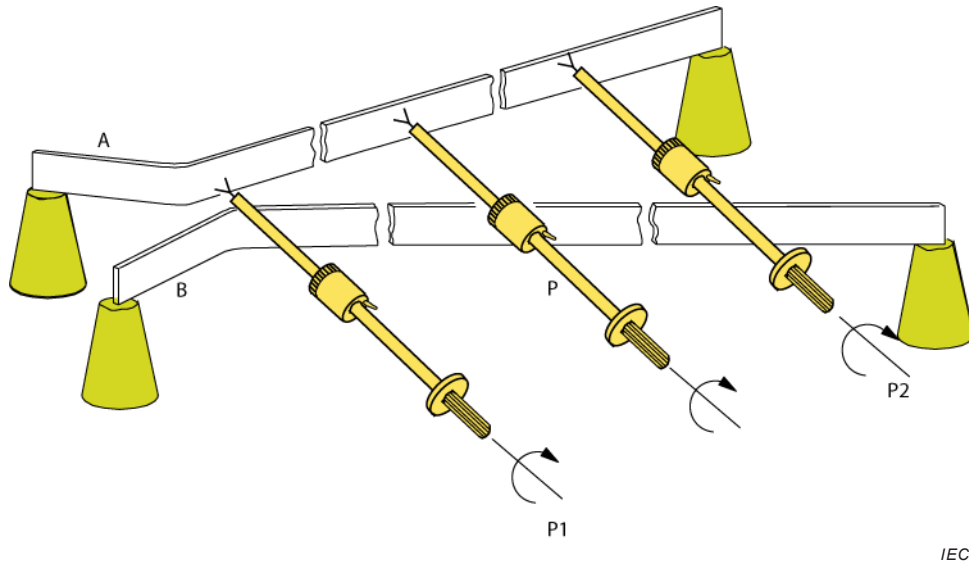

#### Key

- A bar A
- B bar B
- P pole of the *phase comparator*
- P1 initial position of P
- P2 final position of P

**Figure 14 – Radial and surface stress test**

The test shall be considered as passed if no flashover or breakdown occurs.

### 5.3.3 Protection against bridging for outdoor type phase comparator

Each pole of the *phase comparator* shall be tested.

The pole shall be fitted with two conductive band electrodes, which have a width specified in Table 8. These band electrodes are wound around the pole of the *phase comparator*, one at the *contact electrode* and the other in the direction of the handle at a distance  $d_1$  specified in Table 7, column “Outdoor”, measured from the top of the *contact electrode*.

The band electrodes may be shielded by means of concentric rings having the dimensions given in Table 8. The concentric rings shall be electrically connected to the band electrodes.

NOTE In this case, the rings are used to control the electric field around the band electrodes.

**Table 8 – Dimensions for the concentric rings and band electrodes**

Width of band electrodes mm	Concentric rings	
	Outside diameter mm	Cross-section diameter mm
20	200	30

One band electrode shall be connected to an a.c. voltage source, and the other band electrode shall be connected to earth.

For practical reasons, the band electrode nearest to ground is generally connected to earth and the farthest is connected to the a.c. voltage source.

Precipitation shall be performed in accordance with 5.1.3.

The pole of the *phase comparator* shall be aligned at an angle of inclination of  $20^\circ \pm 5^\circ$  to the vertical, in such a way that its *contact electrode* points downwards, and the rain falls at an angle of roughly  $45^\circ$  to the vertical (i.e. at an angle of roughly  $65^\circ$  to the *phase comparator*) (see Figure 15). The precipitation on the test section should be as uniform as possible.

The pole shall be wetted for 3 min. Then, it shall be turned  $180^\circ$  as quickly as possible, so that the *contact electrode* points upwards, and wetted for an additional 2 min.

Then, the test voltage shall be applied for 1 min while the rain continues.

The test voltage shall be  $1,2 U_r$  for a *phase comparator* having a *nominal voltage* lower than or equal to 123 kV.

The test voltage shall be  $1,2U_r/\sqrt{3}$  but shall be greater than 148 kV ( $\approx 1,2$  times 123 kV) for a *phase comparator* having a *nominal voltage* higher than 123 kV.

Bridging tests shall be performed within the limits of the voltage range of the *phase comparator* for each distance  $d_1$  at the highest voltage of each range given by Table 7.

The band electrodes shall be shifted section by section, always maintaining the same distance  $d_1$ , so that the sections overlap by approximately 50 %.

This test shall be repeated until the earthed electrode is at the distance  $d_3$  from the top of the *contact electrode*, with

$$d_3 = A_i + d_1$$

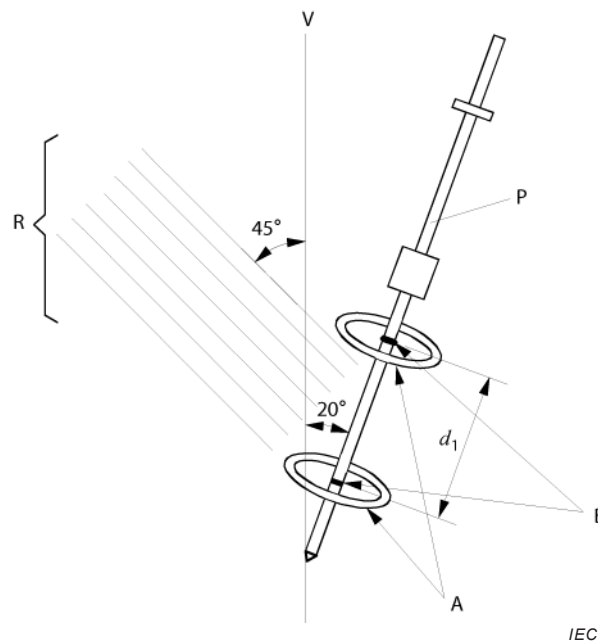
**Key**

- A ring electrodes
- B conductive band electrodes
- P pole of the *phase comparator*
- R precipitation
- V vertical line

**Figure 15 – Test arrangement for testing bridging protection of outdoor type phase comparator**

The test shall be considered as passed if no flashover or breakdown occurs.

For a *phase comparator* with the *insertion depth* shorter than  $d_1$ , the test is only made for distance  $d_1$  from the top of the *contact electrode*.

### 5.3.4 Spark resistance

#### 5.3.4.1 General

For the following test, the *phase comparator* shall be activated.

The test set-up of Figure 11 shall be used for the spark resistance test.

The distance  $d_1$  between bar A and bar B shall be adjusted according to Table 7.

The electrical connections of the bars shall be according to Figure 12.

The test voltage shall be  $1,2 U_r$  for a *phase comparator* having a *nominal voltage* lower than or equal to 123 kV.

The test voltage shall be  $1,2U_r/\sqrt{3}$  but shall be greater than 148 kV ( $\approx 1,2$  times 123 kV) for a *phase comparator* having a *nominal voltage* higher than 123 kV.



#### 5.3.4.2 Type test

##### 5.3.4.2.1 Single-pole phase comparator

The pole shall be moved towards the rear bar until its *contact electrode* touches it. Then the pole shall be moved back, remaining in contact with and supported by the front bar and positioned such that the largest standing spark discharge is created between the *contact electrode* and the rear bar. This can be achieved by moving the pole along the bars and/or moving angularly the pole relatively to the bars. The *phase comparator* shall be kept in this position for 1 min. If it is not possible to have a permanent spark discharge, the test is completed.

The pole shall be moved again towards the rear bar until its *contact electrode* touches it. Then the pole shall be turned and adjusted in the position which provides the largest standing spark discharge between the *indicator* and the front bar. This can be achieved by moving the pole along the bars and/or moving angularly the pole relatively to the bars. The *phase comparator* shall be kept in this position for 1 min. If it is not possible to have a permanent spark discharge, the test is completed.

Finally the *phase comparator* is checked for in-phase relationship by touching the rear bar according to the instructions for use.

The test shall be considered as passed if there is no damage to the *phase comparator*, if it is not shut off and gives *clear indication* of the phase relationship.

##### 5.3.4.2.2 Two-pole wireless phase comparator

The *contact electrode* of one pole shall be connected to the front bar.

The other pole shall be moved towards the rear bar until its *contact electrode* touches it. Then the pole shall be moved back, remaining in contact with and supported by the front bar and positioned such that the largest standing spark discharge is created between the *contact electrode* and the rear bar. This can be achieved by moving the pole along the bars and/or moving angularly the pole relatively to the bars. The *phase comparator* shall be kept in this position for 1 min. If it is not possible to have a permanent spark discharge, the test is completed.

Then the same pole shall be moved again towards the rear bar until its *contact electrode* touches it. Then the pole shall be turned and adjusted in the position which provides the largest standing spark discharge between the *indicator* and the front bar. This can be achieved by moving the pole along the bars and/or moving angularly the pole relatively to the bars. The *phase comparator* shall be kept in this position for 1 min. If it is not possible to have a permanent spark discharge, the test is completed.

The sequence of the test shall be repeated by interchanging the position of the poles.

Finally the *phase comparator* is checked for in-phase relationship by touching the rear bar with the two poles according to the instructions for use.

The test shall be considered as passed if there is no damage to the *phase comparator*, if it is not shut off and gives *clear indication* of the phase relationship.

##### 5.3.4.3 Alternative means for phase comparators having completed the production phase

The manufacturer shall prove that it has followed the same documented assembly procedure as per the type tested device. The manufacturer shall document components that affect the spark resistance.

### 5.3.5 Leakage current for phase comparator as a complete device

#### 5.3.5.1 Type test

##### 5.3.5.1.1 General

Each pole of a *phase comparator* as a complete device shall be tested.

This test is related to the part of a pole of the *phase comparator* as a complete device located between the *limit mark* and the *hand guard*.

The pole of the *phase comparator* shall be fitted with two conductive band electrodes, which, according to the *nominal voltage* of the *phase comparator*, have a width specified in Table 8. These band electrodes are wound around the pole of the *phase comparator*, one adjacent to the *hand guard* in the direction of the *contact electrode* and the other, directly adjacent to the *limit mark* in the direction of the handle.

The band electrodes shall be shielded by means of concentric rings having the dimensions given in Table 8. The band electrodes and the concentric rings shall be electrically insulated from each other.

NOTE In this case, the rings are used to shield the current measuring circuit of the stray capacitive current.

A test voltage of  $1,2 U_r$  shall be applied for a *phase comparator* having a *nominal voltage* lower than or equal to 123 kV.

A test voltage of  $1,2U_r/\sqrt{3}$ , but greater than 148 kV ( $\approx 1,2$  times 123 kV), shall be applied for a *phase comparator* having a *nominal voltage* higher than 123 kV.

For a *phase comparator* with a *nominal voltage* range the test voltage shall be as defined above and related to the higher value of the *nominal voltage*.

Leakage currents shall be measured according to the following procedure.

##### 5.3.5.1.2 Leakage current under dry conditions

In a first step the leakage current (rms value) shall be measured under dry conditions while the test voltage is applied for 1 min.

The band electrode at the *hand guard* shall be connected to earth through an ammeter by means of an earthed shielded cable. The adjacent concentric ring shall be connected to earth directly. The band electrode and the concentric ring at the *limit mark* shall be connected to the test voltage (see Figure 16).

Provisions should be taken to avoid any unwanted interference with the measurement.

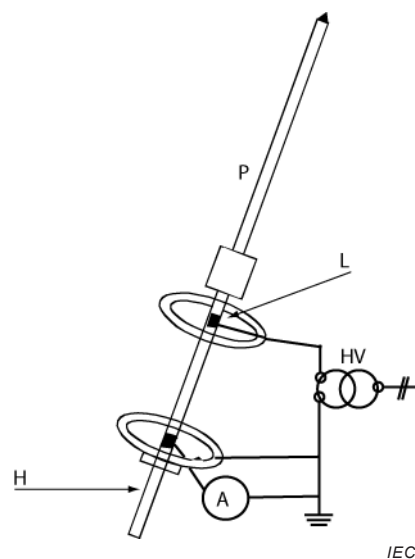
**Key**

A	ammeter	L	limit mark
H	handle	P	pole of the <i>phase comparator</i>
HV	high voltage source		

**Figure 16 – Arrangement for leakage current test under dry conditions for phase comparator as a complete device**

The test shall be considered as passed if the leakage current for each pole never exceeds  $50 \mu\text{A}$ .

### 5.3.5.1.3 Leakage current under wet conditions for outdoor type

For *outdoor type phase comparators*, a wet test is also required.

Precipitation shall be performed in accordance with 5.1.3.

The rain shall fall at an angle of roughly  $45^\circ$  to the vertical. The precipitation on the test section covering the complete insulating length should be as uniform as possible.

The pole of the *phase comparator* shall be placed on an earthed plane and shall be aligned at an angle of inclination of  $20^\circ \pm 5^\circ$  to the vertical, with its *contact electrode* downward (i.e. an angle of roughly  $65^\circ$  between rainfall and the pole of the *phase comparator*). The band electrode near the *limit mark* shall be connected to earth through the ammeter. The *contact electrode* and the concentric ring near the *limit mark* shall be earthed. The band electrode and the concentric ring near the handle shall be connected to the test voltage (see Figure 17a).

The pole of the *phase comparator* shall be wetted for 15 min. While the rain continues, the test voltage shall be applied for 1 min and the leakage current shall be measured. The maximum value of the leakage current shall be recorded.

In order to avoid the measurement of current spikes due to water drops and stream, the ammeter should give at least an averaging time of 1 s and its input should be equipped with an appropriate RC filter cutting frequencies above 240 Hz.

The pole of the *phase comparator* shall then be turned  $180^\circ$ , so that the *contact electrode* points upwards. The band electrode near the handle shall be connected to earth through the ammeter and its adjacent concentric ring shall be earthed. The *contact electrode*, the band electrode and the concentric ring near the *limit mark* shall be connected to the test voltage (see Figure 17b).

The pole of the *phase comparator* shall be wetted for an additional 15 min. While the rain continues, the test voltage shall be applied for 1 min and the leakage current shall be measured. The maximum value of the leakage current shall be recorded.

The test shall be considered as passed if the leakage current for each pole under wet conditions never exceeds 0,5 mA.

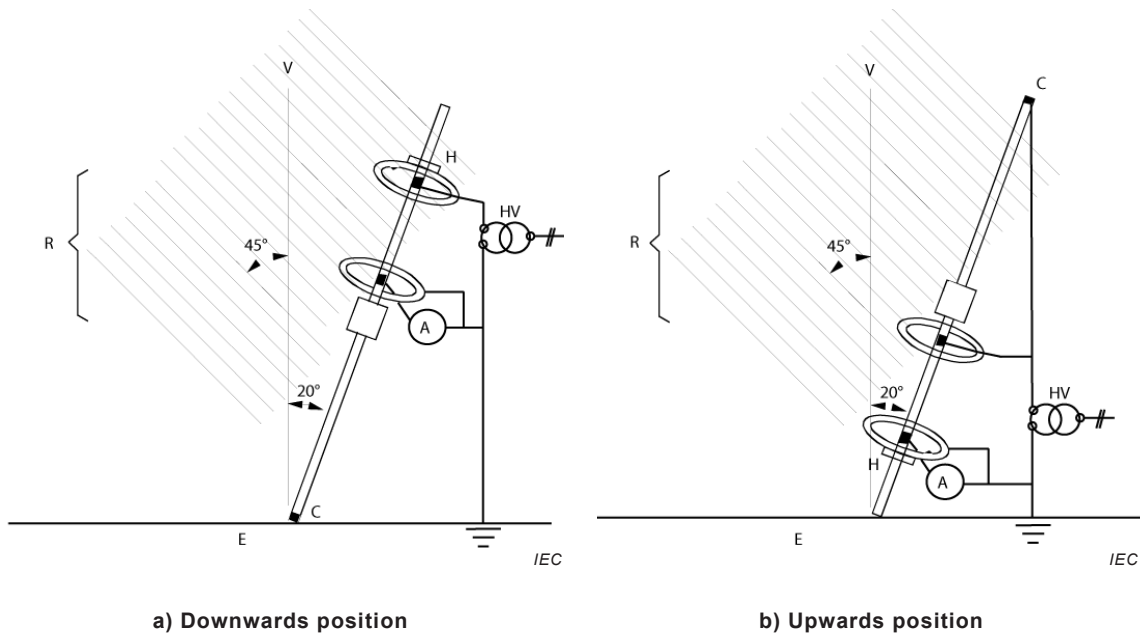

**Key**

A	ammeter	HV	high voltage source
C	contact electrode	R	precipitation
E	earthed plane	V	vertical line
H	handle		

**Figure 17 – Arrangement for leakage current tests under wet conditions for phase comparator as a complete device**

**5.3.5.2 Alternative test for phase comparators having completed the production phase**

The manufacturer may use an alternative test set-up to check that the leakage current under dry conditions does not exceed the value given in 5.3.5.1.2.

**5.4 Mechanical tests**

**5.4.1 Visual and dimensional inspection**

**5.4.1.1 Visual inspection**

The complete *phase comparator* shall be tested for compliance with the relevant requirements of 4.4.1, 4.4.2, 4.4.3, 4.5 and 4.6. It shall be verified that the user does not have access to the settings according to 4.2.1.2.

**5.4.1.2 Dimensional inspection**

The *phase comparator* shall be checked for compliance with the requirements of 4.4.3 and 4.5.

### 5.4.2 Grip force and deflection for phase comparator as a complete device

The pole(s) of the assembled *phase comparator* shall be kept in a horizontal position by means of two supports. One support (front support) shall be located 50 mm from the *hand guard*, towards the end of the handle. The other support (rear support) shall be located 50 mm from the end of the handle. The distance between the two supports shall never exceed 1 000 mm (see Figure 18).

If the handle is longer than 1 100 mm the support at the free end of the handle shall be set at a distance of 1 000 mm from the front support.

*Dimensions in millimetres*

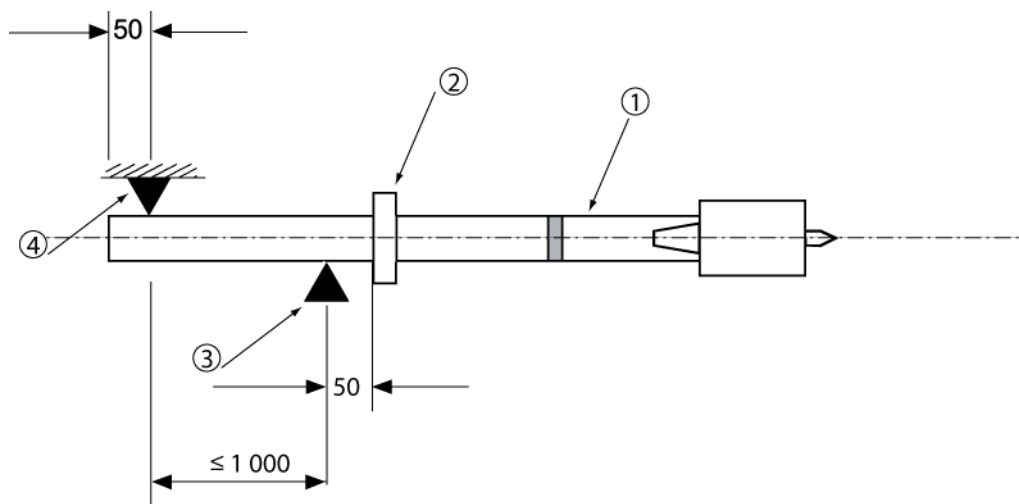

#### Key

1	pole of the <i>phase comparator</i>	3	front support
2	<i>hand guard</i>	4	rear support

**Figure 18 – Test for grip force**

The grip force shall be measured at the front support and shall be less than 200 N.

In the test position described above, the deflection of each pole shall be measured. The value shall not exceed 10 % of the total length of each pole.

### 5.4.3 Vibration resistance

#### 5.4.3.1 Type test

The test shall be performed on each pole. If relevant, the *indicator unit(s)* of the *phase comparator* shall also be subjected to the test.

The test method shall be in accordance with IEC 60068-2-6.

In the case of a *phase comparator* as a separate device the pole shall be tested without an attachable *insulating stick*. In the case of a *phase comparator* as a complete device the pole shall be tested without its *insulating element* (if possible). The pole of the *phase comparator* shall be fastened to the vibrator by rigid intermediate parts which shall not affect the test results.

To attenuate any large amplitude oscillations which may be induced in the *contact electrode* during the test, the free ends of the electrodes shall be fastened to the rigid part.

The assembly shall be submitted to sinusoidal rectilinear vibrations in two perpendicular directions, one of which corresponds to the long axis of the pole of the *phase comparator*.

The sweep (run of the specified frequency range, once in each direction) shall be continuous and the sweeping rate shall be approximately one octave per minute. The frequency range shall be from 10 Hz to 150 Hz.

The amplitude and acceleration shall be as follows:

- 0,15 mm peak value between 10 Hz and 58 Hz;
- 19,6 m/s<sup>2</sup> (2 g) peak value between 58 Hz and 150 Hz.

The duration of the test shall be set for 2 h in each direction.

The test shall be considered as passed if the pole of the *phase comparator* shows no signs of mechanical damage.

#### **5.4.3.2 Alternative means for phase comparators having completed the production phase**

It is not practical to perform the vibration test after completing the production phase for checking the conformity to the associated requirements. Nevertheless the manufacturer shall prove that it has followed the same documented assembly procedure as per the type tested device. The manufacturer shall document components that affect the vibration resistance.

#### **5.4.4 Drop resistance**

##### **5.4.4.1 Type test**

The test shall be performed on each pole. If relevant, the *indicator unit(s)* of the *phase comparator* shall also be subjected to the test.

The test shall be performed in accordance with free fall, procedure 1, of IEC 60068-2-31 with the following parameters:

- the test surface shall be concrete or steel. The test surface shall be smooth, hard and rigid;
- the pole of the *phase comparator* shall be dropped from horizontal, and from diagonal static positions;
- the height of fall shall be 1 m from the horizontal position;
- the height of fall shall be 1 m plus 20 % of the overall length of the *phase comparator* for the diagonal position. For the diagonal position, the height of fall shall be the distance between the end of the *contact electrode*, projected onto a vertical axis, and the floor (see Figure 19). In the case of the pole of the *phase comparator* with overall length lower than 1,2 m, the *phase comparator* shall be dropped from the vertical position with the *contact electrode* upward. This parameter does not apply to the *indicator unit*;
- the number of falls shall be one per position.

The test shall be considered as passed if the pole of the *phase comparator* shows no signs of mechanical damage even if the *contact electrode* is bent without destruction.

If the *insulating stick* is not provided, the test shall be performed with an *insulating stick* having the minimum constructive dimensions specified in 4.4.3.

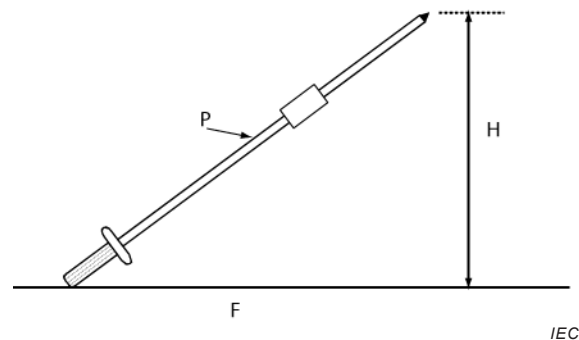
**Key**

- P pole of a *phase comparator*  
H height of fall  
F test surface (floor)

**Figure 19 – Drop resistance test – Diagonal position**

#### **5.4.4.2 Alternative means for phase comparators having completed the production phase**

It is not practical to perform the drop test after completing the production phase for checking the conformity to the associated requirements. Nevertheless the manufacturer shall prove that it has followed the same documented assembly procedure as per the type tested device. The manufacturer shall document components that affect the drop resistance.

#### **5.4.5 Shock resistance**

##### **5.4.5.1 Type test**

The test is designed to check the sturdiness of the *phase comparator*. The test method shall be in accordance with the IEC 60068-2-75 pendulum method.

The most fragile part of the *phase comparator* shall be submitted to shock five times. The same location on the most fragile part shall be shocked only once.

The impact energy shall be 5 J.

The test shall be considered as passed if the *phase comparator* shows no sign of mechanical damage.

#### **5.4.5.2 Alternative means for phase comparators having completed the production phase**

It is not practical to perform the shock test after completing the production phase for checking the conformity to the associated requirements. Nevertheless the manufacturer shall prove that it has followed the same documented assembly procedure as per the type tested device. The manufacturer shall document components that affect the shock resistance.

#### **5.4.6 Climatic resistance**

##### **5.4.6.1 Type test**

Before this test, each pole of the *phase comparator* shall be cleaned with isopropanol and then dried in air for 15 min.

The test is performed at least on the *indicator* for each pole, if so equipped, in accordance with IEC 60068-2-14 except for the temperature cycles and time relative to humidity. In this case, the test cycle shall be in accordance with the following (see Figure 20). When performing the test on a two-pole *phase comparator* the test is performed simultaneously on both poles. If relevant, the *indicator unit(s)* of the *phase comparator* shall also be subjected to the test.

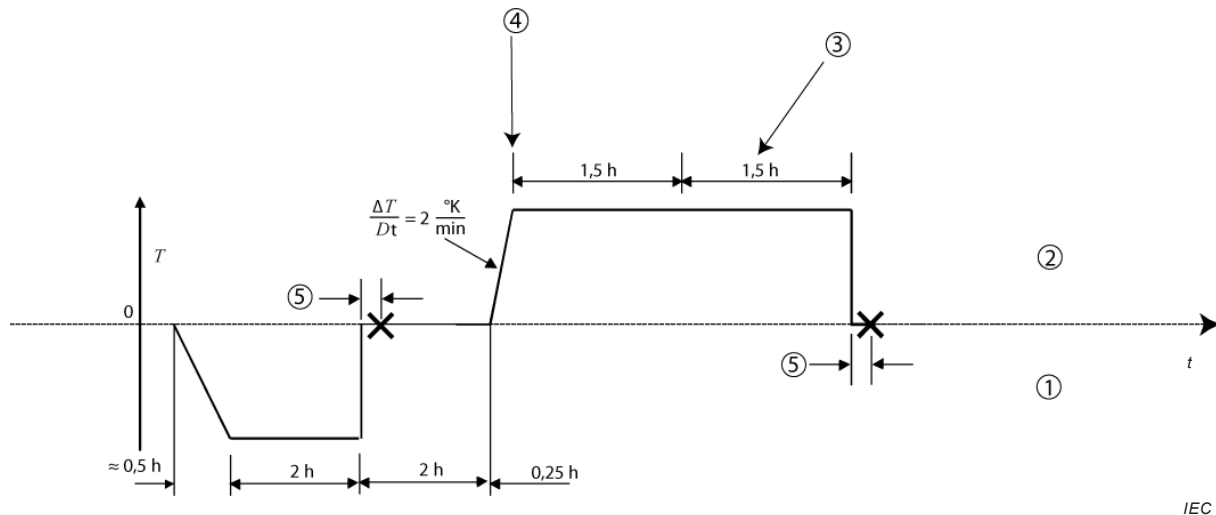

#### Key

<b>X</b>	test point	3	humidity 96 %
1	low temperature	4	humidity 50 %
2	high temperature	5	5 min to 10 min time period

**Figure 20 – Curve of test cycle for climatic resistance**

The parts of the *phase comparator* submitted to climatic conditioning shall be placed in a climatic chamber. The temperature of the chamber is lowered from the ambient temperature to the required low value according to the climatic category of the *phase comparator* (see Table 1). The temperature of the chamber shall be maintained for 2 h.

The parts of the *phase comparator* submitted to climatic conditioning shall then be removed from the climatic chamber and within 5 min to 10 min following the withdrawal, the *phase comparator* shall be assembled and the test shall be carried out according to 5.2.2, test series 2 and 3, at ambient temperature. Wiping of external parts is allowed.

The parts of the *phase comparator* submitted to climatic conditioning shall be kept at ambient temperature for 2 h.

The parts of the *phase comparator* submitted to climatic conditioning shall next be placed in the climatic chamber and the temperature shall be increased 2 K/min until it reaches the high value according to the climatic category of the *phase comparator* (see Table 1). The relative humidity shall be maintained at 50 %.

The chamber shall be kept at the high temperature for 3 h. During the first hour and half, the relative humidity shall be increased from 50 % to 96 %.

The parts of the *phase comparator* submitted to climatic conditioning shall then be removed from the climatic chamber and within 5 min to 10 min following the withdrawal, the *phase comparator* shall be assembled and the test shall be carried out according to 5.2.2, test series 2 and 3, at ambient temperature. Wiping of external parts is allowed.



The test shall be considered as passed if the *phase comparator* always gives correct indications.

NOTE This test procedure combines conditions of steady extreme temperatures and sudden change of temperature, since it is not practical to perform high voltage tests in a climatic chamber.

#### **5.4.6.2 Alternative means for phase comparators having completed the production phase**

It is not practical to perform the test under climatic conditions after completing the production phase for checking the conformity to the associated requirements. Nevertheless the manufacturer shall prove that it has followed the same documented assembly procedure as per the type tested device. The manufacturer shall document components that affect the climatic performance.

#### **5.4.7 Durability of markings**

The markings shall be rubbed successively with a rag soaked in water for at least 1 min, then with another rag soaked in isopropanol for another minimum of 1 min.

The test is considered as passed if the markings remain legible and the letters do not smear.

The surface of the *phase comparator* may change. No signs of loosening shall be present for labels.

Marking produced by an engraving or moulding process shall be deemed to comply without test.

### **5.5 Test for reasonably foreseeable misuse during live working**

#### **5.5.1 Voltage selection (where relevant)**

The voltage selector of the *phase comparator* shall be switched at the lowest position. The test for *clear indication* shall be performed at the highest *nominal voltage* of the voltage ranges.

The test shall be considered as passed if the device gives no incorrect indication, and no phenomenon occurs which could cause a danger to the user.

#### **5.5.2 Frequency selection (where relevant)**

The frequency selector of the *phase comparator* shall be switched at 50 Hz position. The test for *clear indication* shall be performed at 60 Hz.

The test shall be considered as passed if the device gives no indication, and no phenomenon occurs which could cause a danger to the user.

#### **5.5.3 Channel selection for wireless connection (where relevant)**

The channel selector of one unit of the wireless *phase comparator* shall be put at a certain position (a certain frequency) and the channel selector of the other units shall be put at the closest adjacent frequency. The test for *clear indication* shall be performed at the highest voltage of the voltage ranges.

The test shall be considered as passed if the device gives no indication.

## 6 Conformity assessment of phase comparators having completed the production phase

For conducting the conformity assessment during the production phase, IEC 61318 shall be used in conjunction with the present standard.

Annex D, developed from a risk analysis on the performance of the *phase comparator*, provides the classification of defects and identifies the associated tests applicable in the case of production follow-up.

## 7 Modifications

Any modification of the *phase comparator* shall require:

- a repeat of the type tests, in whole or in part (if the degree of modification so justifies);
- an update of the *phase comparator* reference literature.

## Annex A (normative)

### Instructions for use

Instructions for use that contain all the information necessary for the use and care of the *phase comparator* shall be supplied with every *phase comparator*.

These include, where applicable, the following as a minimum:

- information that the *phase comparators* are designed to be used by trained or skilled persons and in accordance with the hot stick working method;
- statement that a *phase comparator* as covered by this standard is to be used on parts at the same voltage and the same frequency;
- statement that a *phase comparator* as covered by this standard is not to be used as a voltage detector;
- explanation of the marking;
- instructions for proper usage;
- for *phase comparators* with any selector, explanation of correct selection, possible misuse and its consequences;
- statement and explanation of the maximum time rating;
- explanation of the assembly of the *phase comparator* (if relevant);
- explanation of the *limit mark* and the *hand guard*;
- significance of the indication signals;
- explanation of the proper use of the *testing element* and statement of any limitations (for example, when the *testing element* is not testing all circuits);
- for a wireless *phase comparator*, statement of the maximum distance range in free space between the various units as well as the conditions (buildings, weather conditions, etc.) in which this range may be reduced;
- explanation of the marking “LU” and its purpose concerning the proper use;
- explanation concerning the possible use of *accessories* especially the use of a *contact electrode extension*;
- identification of *accessories* and combination of *accessories* that have been submitted with the *phase comparator* to the type test;
- explanation concerning the possible effect of *accessories* on the performances of the *phase comparator* especially the use of different *contact electrodes* and *contact electrode extensions*;
- statement concerning the possible use on factory-assembled switchgear;
- explanation concerning the limits within which the voltage of the parts of the installation to be compared may vary giving at the same time a *clear indication*;
- statement concerning possible effects of *interference field*;
- statement concerning the duration that the *phase comparator* may be in contact with installations while exposed to precipitation;
- in the case of a *phase comparator* as a separate device, a statement that the choice of an *insulating stick* may greatly influence the grip force and deflection;
- instructions for storage and care;
- instructions for periodic *maintenance tests*;
- instructions for transport;

- statement concerning which parts of the *phase comparator* can be replaced by the user and what parameters shall be maintained in doing so;
- statement concerning the type, the minimum length of the *insulating element* and the dielectric properties of the *insulating stick* that has to be used in conjunction with the *phase comparator* as a separate device;
- statement regarding the d.c. indication.

**Annex B**  
(normative)

**Suitable for live working; double triangle**  
(IEC 60417-5216 (2002-10))

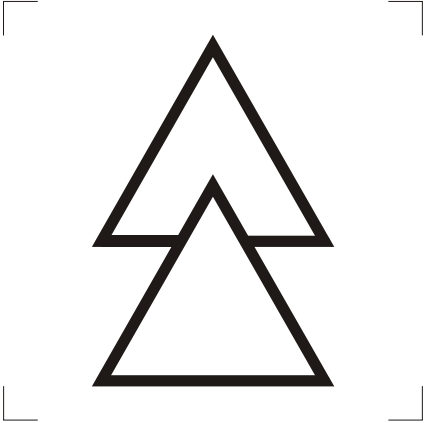

## Annex C (normative)

### Chronology of type tests

**Table C.1 – Sequential order for performing type tests<sup>a</sup>**

Sequential order	Type tests	Subclauses	Requirements
1	Visual and dimensional inspection	5.4.1	4.1, 4.2.1.1, 4.4.2, 4.4.3, 4.5, 4.6
2	Vibration resistance	5.4.3.1	4.4.5
2	Drop resistance	5.4.4.1	4.4.6
2	Shock resistance	5.4.5.1	4.4.7
3	<i>Clear indication</i>	5.2.2	4.2.1
4	Climatic resistance	5.4.6.1	4.2.4
4	Frequency dependence		
	– Tolerance of nominal frequency	5.2.7.1.1	4.2.5.2
	– Frequency shift	5.2.7.2.1	4.2.5.3
4	Power source dependability (or out of sequence)	5.2.9.1	4.2.7
5	<i>Protection against bridging for indoor/outdoor type phase comparator</i>	5.3.2	4.3.2, 4.3.5
5	<i>Protection against bridging for outdoor type phase comparator</i>	5.3.3	4.3.2, 4.3.5
6	Spark resistance	5.3.4.2	4.3.3
7	Distance range for wireless connection	5.2.3	4.2.2
8	Time rating		
	– single-pole phase comparator	5.2.11.1	4.2.9
	– two-pole wireless phase comparator	5.2.12.1	
9	Check of <i>testing element</i>	5.2.10.1	4.2.8
9	Influence of electric <i>interference fields</i>	5.2.5	4.2.1.3
10	Leakage current under dry conditions for a <i>phase comparator</i> as a complete device	5.3.5.1.2	4.3.4.2
11	Leakage current under wet conditions for an <i>outdoor type phase comparator</i> as a complete device	5.3.5.1.3	4.3.4.2
12	Channel selection in the case of misuse of <i>phase comparator</i> with wireless connection	5.5.3	4.7.3
13	Voltage selection in the case of misuse	5.5.1	4.7.1
13	Frequency selection in the case of misuse	5.5.2	4.7.2

<sup>a</sup> Type tests with the same sequential number can be performed in the more convenient order.

**Table C.2 – Type tests out of sequence**

<b>Type tests</b>	<b>Subclauses</b>	<b>Requirements</b>
Durability of marking	5.4.7	4.5
Grip force and deflection for <i>phase comparator</i> as a complete device	5.4.2	4.4.4
<i>Clear perceptibility</i> of visual indication	5.2.6.1.1 5.2.6.1.2	4.2.3.1
<i>Clear perceptibility</i> of audible indication (if available)	5.2.6.2.1 5.2.6.2.2	4.2.3.2
<i>Response time</i>	5.2.8.1	4.2.6
EMC	5.2.4.1	4.2.1.6
Insulating materials (for tubes and rods used for <i>phase comparator</i> as a complete device)	5.3.1.1	4.3.1

## Annex D (normative)

### Classification of defects and tests to be allocated

Annex D was developed to address the type of defects of a manufactured *phase comparator* (critical, major or minor) in a consistent manner (see IEC 61318). For each requirement identified in Table D.1, both the type of defect and the associated test are specified. Annex F defines the rationale for the classification of defects.

**Table D.1 – Classification of defects and associated requirements and tests**

Requirements		Type of defects			Test
		Critical	Major	Minor	
4.4.3	Minimum length of the <i>insulating element</i> for a <i>phase comparator</i> as a complete device	X			5.4.1.2
4.5	Correctness of the marking of the <i>phase comparator</i>	X			5.4.1.1
4.3.4.2	Leakage current along the <i>insulating element</i> of a <i>phase comparator</i> as a complete device	X			5.3.5.2
4.2.1	<i>Clear indication</i> of the status of the phase relationship	X			5.2.2
4.2.1.3	Effect of <i>interference fields</i> (continuous indication)	X			<sup>b</sup>
4.3.2	<i>Protection against bridging</i> for indoor/outdoor type <i>phase comparator</i>	X			5.3.2
	<i>Protection against bridging</i> for outdoor type <i>phase comparator</i>	X			5.3.3 <sup>a</sup>
4.3.3	Spark resistance		X		5.3.4.3
4.2.6	<i>Response time</i> only for <i>phase comparators</i> with one <i>active signal</i> "incorrect phase relationship" or "correct phase relationship" and with a <i>response time</i> below or equal to 1 s	X			5.2.8.2
	<i>Response time</i> only for <i>phase comparators</i> with one <i>active signal</i> "incorrect phase relationship" or "correct phase relationship" and with a declared <i>response time</i> above 1 s or with two <i>active signals</i>			X	
4.2.5.2	Frequency dependence – Tolerance of nominal frequency	X			5.2.7.1.2
4.2.5.3	– Frequency shift				5.2.7.2.2
4.2.4	Temperature and humidity dependence of the indication	X			5.4.6.2
4.2.3	<i>Clear perceptibility</i> : only visual		X		5.2.6.1.3
	<i>Clear perceptibility</i> : visual and audible			X	5.2.6.2.3
4.4.5	Vibration resistance	X			5.4.3.2
4.4.6	Drop resistance	X			5.4.4.2
4.4.7	Shock resistance	X			5.4.5.2
4.2.2	Distance range		X		5.2.3
4.2.8	Functioning of the <i>testing element</i>		X		5.2.10.2
4.2.7	Power source dependability	X			5.2.9.2
4.2.1.6	EMC emission EMC immunity	X		X	5.2.4.2



Requirements		Type of defects			Test
		Critical	Major	Minor	
4.2.9	Time rating for single pole <i>phase comparator</i>		X		5.2.11.2
	Time rating for two- pole wireless <i>phase comparator</i>		X		5.2.12.2
4.5	Marking: availability and durability		X		5.4.1.1 5.4.7
4.4.4	Grip force and deflection			X	5.4.2
4.6	Instructions for use (availability)	X			5.4.1.1
4.3.1	Insulating material for tubes and rods of <i>phase comparator</i> as complete device	X			5.3.1.2
4.3.5	<i>Indicator</i> casing (dielectric property)	X			5.3.2 5.3.3 <sup>a</sup>
<p><sup>a</sup> For <i>outdoor type phase comparators</i> the tests are performed in dry conditions only.</p> <p><sup>b</sup> At the production level there is no need to perform a test associated with this requirement. The confirmation of the <i>clear indication</i> according to 5.2.2 confirms the correctness of the performance of the device to give a correct indication under the <i>interference field</i>.</p>					

## Annex E (informative)

### Information and guidelines on the use of the limit mark and of a contact electrode extension

#### E.1 General

Annex E aims at providing additional information on the purpose and use of the *limit mark*, which is a mandatory part of a *phase comparator* as a complete device and of the *contact electrode extension* which is an *accessory* to a *phase comparator*.

#### E.2 Situation when using a phase comparator as a complete device

As defined in Clause 3 of this standard, the *limit mark* is a distinctive location or mark to indicate to the user the physical limit to which the *phase comparator* may be inserted between live parts or may touch them.

The worker handling a *phase comparator* as a complete device is provided with an adequate insulation by the *insulating element* which is defined by the distance between the *limit mark* and the *hand guard* (see Figure E.1).

This standard specifies a minimum length of the *insulating element* of a *phase comparator* as a complete device (Table 2). A user may specify for a longer length.

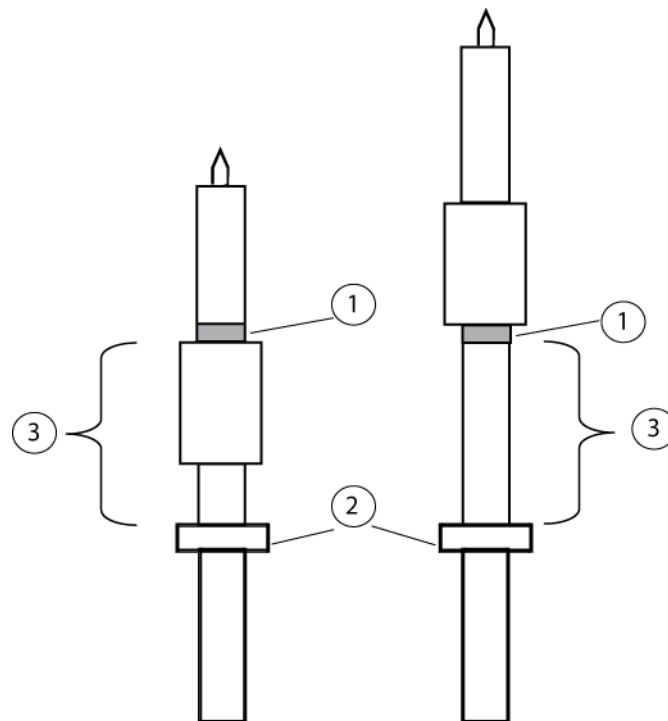

IEC

#### Key

- 1 *limit mark*
- 2 *hand guard*
- 3 *insulating element*

Figure E.1 – Insulating element of a pole of a phase comparator as a complete device

When handling a *phase comparator* near live parts of an electrical installation, the worker should always make sure that the device will approach the live parts in a way so as to not shorten in any unsafe manner the insulation distance between the *limit mark* and the *hand guard*.

The *limit mark* is a physical way to indicate to the worker the limit of insertion of the device between live parts. Any live part contacting the *phase comparator* in any location between the *limit mark* and the *hand guard* will shorten the insulation distance.

When the worker positions the *phase comparator* right under a live part, with no obstacles in between (see Figure E.2), the *limit mark* has no significant use.

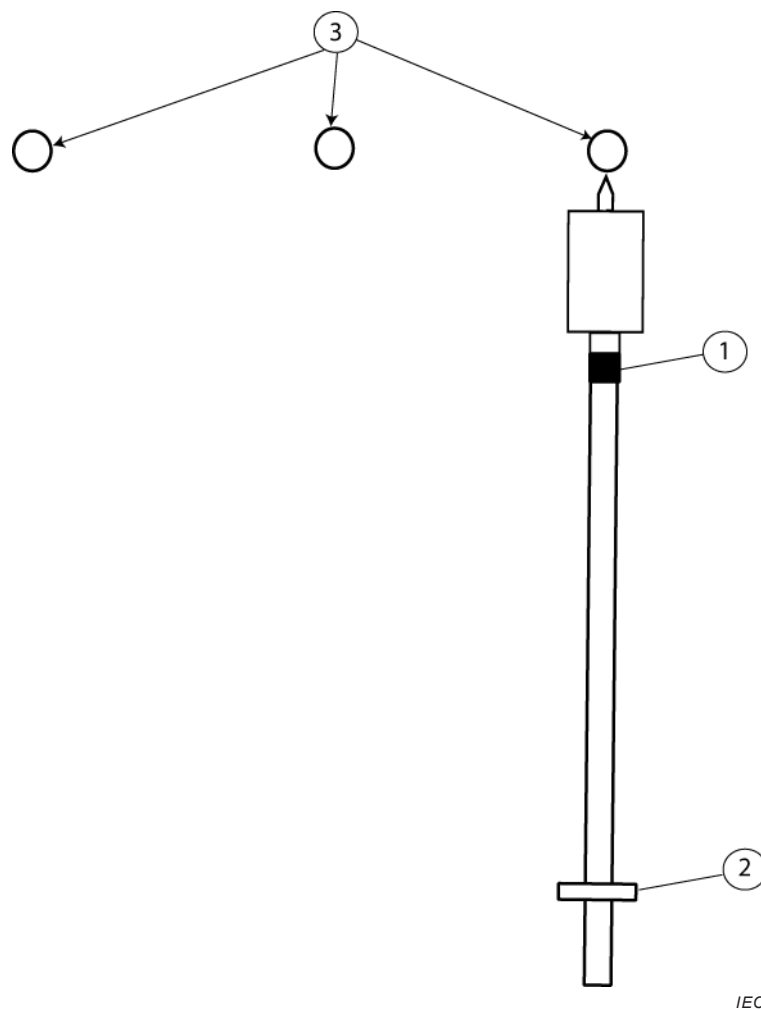
**Key**

- 1 *limit mark*
- 2 *hand guard*
- 3 live parts

**Figure E.2 – Example of positioning of a pole of a phase comparator in contact with a live part without obstacles from other live parts**

However, in some installation configurations, the worker may have to approach a live part by positioning the *phase comparator* close to another live part, under or over it. In such a situation, to have the *limit mark* going between the live parts would reduce the insulation distance (see Figure E.3). This has to be avoided.

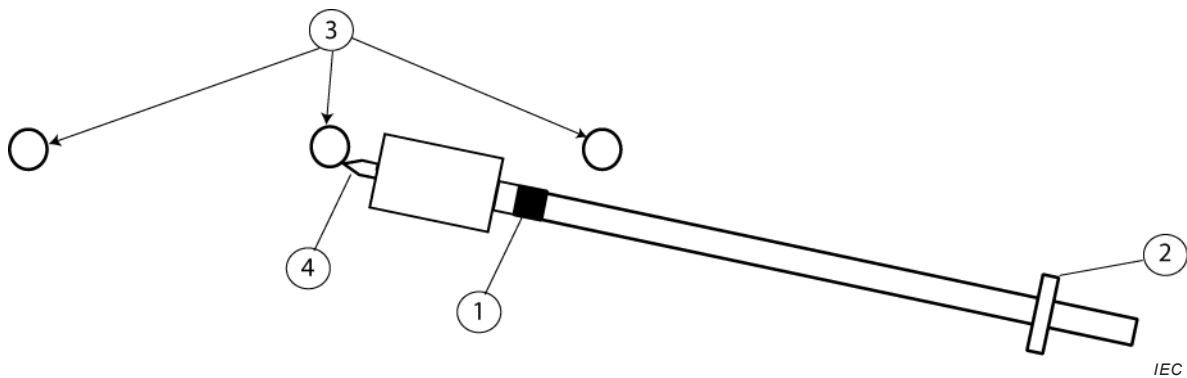
**Key**

- 1 *limit mark*
- 2 *hand guard*
- 3 *live parts*
- 4 *contact electrode*

**Figure E.3 – Example of incorrect positioning of a pole of a phase comparator with the limit mark between two live parts**

To avoid such situation, the distance between the *contact electrode* and the *limit mark* of the *phase comparator* has to be extended in such a way that it exceeds the usual distances between live parts for a given operating voltage.

Two usual ways for achieving that are,

- the use of a suitable length of *permanent contact electrode extension* by a proper design of the device, or
- the use of a *contact electrode extension* as an *accessory* to the *phase comparator*.

Both ways are illustrated in Figure E.4.

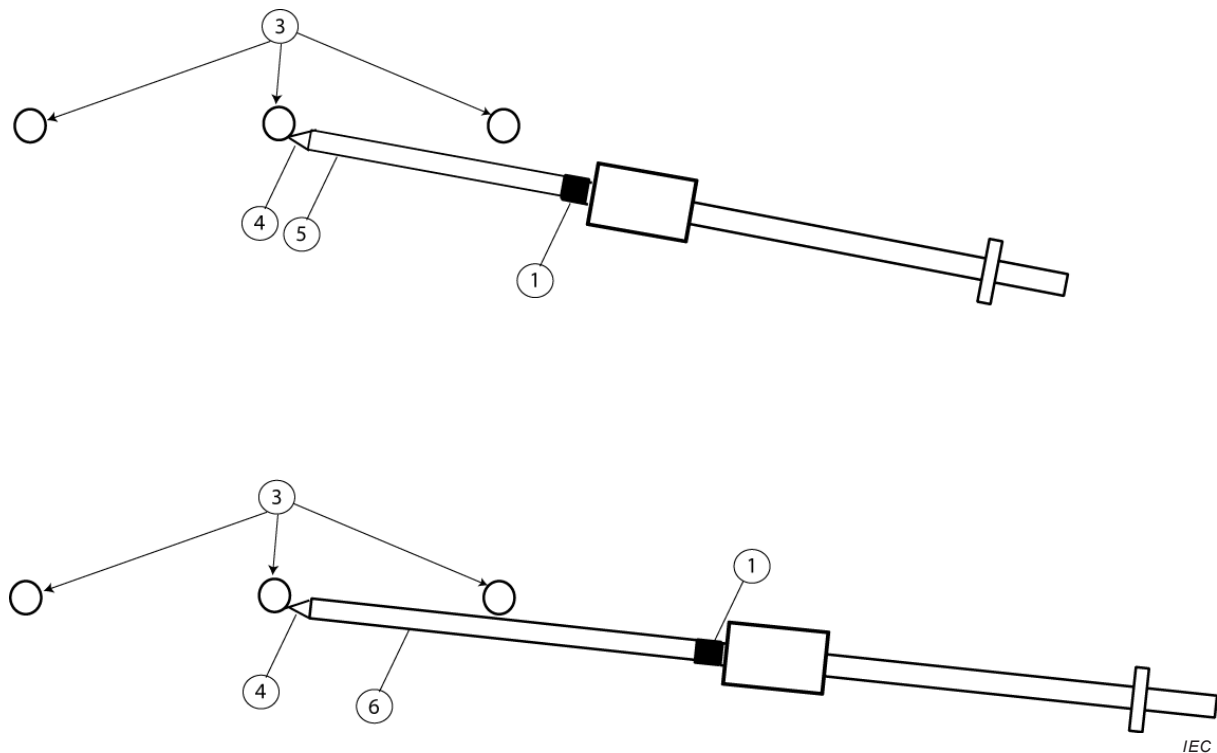

**Key**

- 1 *limit mark*
- 3 *live parts*
- 4 *contact electrode*
- 5 *permanent contact electrode extension*
- 6 *contact electrode extension*

**Figure E.4 – Usual ways of managing the design or the use of the phase comparator for maintaining the insulation distance between the limit mark and the hand guard**

For the design of a proper length of *insulating element*, Table E.1 provides recommended minimum distances from the *limit mark* to the *contact electrode* identified as the *insertion depth* ( $A_i$ ) for different values of *nominal voltages*.

**Table E.1 – Recommended minimum lengths from the limit mark to the contact electrode ( $A_i$ )**

$U_n$ kV	$A_i$ mm
$1 < U_n \leq 12$	300
$12 < U_n \leq 24$	450
$24 < U_n \leq 36$	600
$36 < U_n \leq 72,5$	1 200

NOTE The values are selected in consideration of the extension that is necessary for the usual construction type of three-phase systems. In certain circumstances, larger lengths may be required and agreed between manufacturer and customer.

### E.3 Situation when using a phase comparator as a separate device

A pole of a *phase comparator* as a separate device is equipped with an *adaptor* to permit its attachment to an *insulating stick*. The *insulating stick* is a separate tool, and its general performance, as well as its length, is the responsibility of the user.

In a certain way, the *adaptor* of a *phase comparator* as a separate device may be associated to the *limit mark* of a *phase comparator* as a complete device in the sense that the insulation of the worker will be provided by the *insulating element* of the *insulating stick* that is identified as the distance between the *adaptor* and the *hand guard* of the *insulating stick*.

However, while the *insulating element* of a *phase comparator* as a complete device is of a determined length corresponding to the design of the manufacturer, the length of the *insulating stick* and the determination of the distance between the *adaptor* and the *hand guard* of the stick are the responsibility of the users and may be influenced by the working procedures.

When managing the positioning of the *phase comparator* between live parts, the user has two possible ways to achieve that:

- the use of a *contact electrode extension* as an *accessory* to the *phase comparator*,
- the use of an *insulating stick* of a length longer than the minimum length of insulation towards the *hand guard* that will allow the *adaptor* of the *insulating stick* to be between live parts (see Figure E.5).

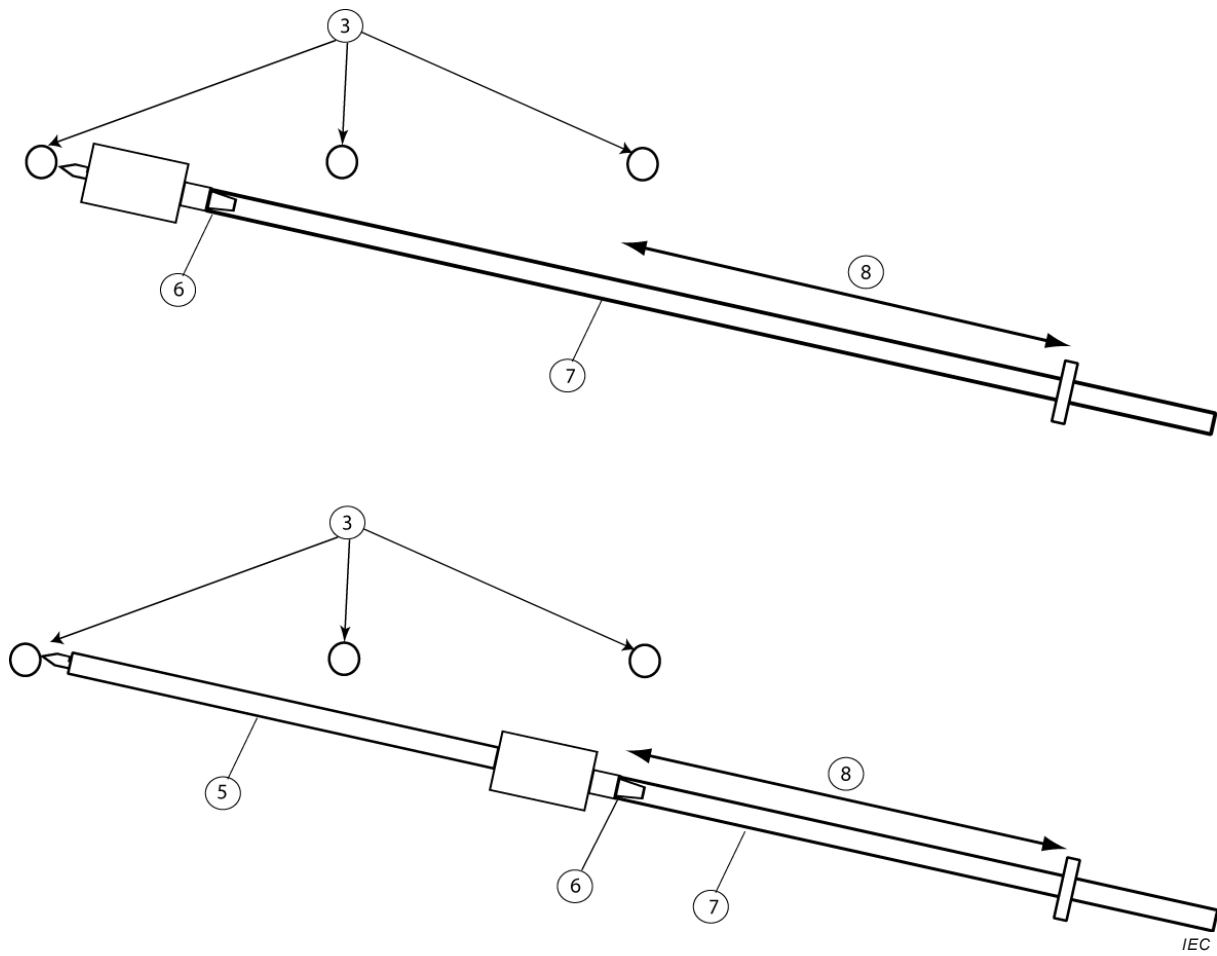

**Key**

- 3 live parts
- 5 *contact electrode extension*
- 6 *adaptor*
- 7 *insulating stick of the appropriate length*
- 8 minimum length of insulation (under the responsibility of the users and influenced by the working procedures)

**Figure E.5 – Usual ways of managing the use of the phase comparator as a separate device for assuring the appropriate insulation for the worker**

## Annex F (informative)

### Rationale for the classification of defects

Annex F provides the rationale for the classification of defects specified in Annex D. For a brand new *phase comparator*, Table F.1 presents the justification for the type of defect associated with a lack of compliance with each of the requirements included in the standard.

This analysis takes into consideration that *phase comparators* are used by persons trained for the work, in accordance with the hot stick working method and the instructions for use.

**Table F.1 – Rationale for the classification of defects**

Requirement	Justification for the associated defect specified in Annex D
<b>Critical defects</b>	
Minimum length of the <i>insulating element (phase comparator as a complete device)</i>	A shorter length of the <i>insulating element</i> can result in an unacceptable value of leakage current and/or can lead to a breakdown during use.
Leakage current ( <i>phase comparator as a complete device</i> )	The <i>insulating element</i> of a <i>phase comparator</i> as a complete device is the protection of the worker during each use of the device. On a brand new device a value of leakage current above the limit is a hazard for the initial worker.
<i>Clear indication</i> of the status of the phase relationship	If the <i>phase comparator</i> gives a false indication (for example " <i>Correct</i> " instead of " <i>Incorrect</i> ") it can lead to a hazardous situation.
Effect of <i>interference fields</i> (continuous indication)	If the <i>phase comparator</i> gives a false indication (for example " <i>Correct</i> " instead of " <i>Incorrect</i> ") it can lead to a hazardous situation.
Electromagnetic – Immunity	If the <i>phase comparator</i> does not fulfil the immunity requirements, it can give wrong indications.
Temperature and humidity dependence of the indication	If the <i>phase comparator</i> does not work properly in its temperature range, it could give a false indication and lead to a hazardous situation for the worker.
Frequency dependence – Tolerance of nominal frequency – Frequency shift (single-pole <i>phase comparator</i> )	If the <i>phase comparator</i> does not work properly in its frequency range, it can give a false indication and lead to a hazardous situation for the worker.
<i>Response time</i> only for <i>phase comparators</i> with one <i>active signal</i> "incorrect phase relationship" or "correct phase relationship" and with a <i>response time</i> below or equal to 1 s	If for any reasons the <i>response time</i> becomes longer than 1 s, the worker could conclude a non answer as an indication. This could lead to a hazardous situation for the worker.
Power source dependability	The purpose of this requirement is to ensure that the <i>phase comparator</i> will indicate properly until the built-in power source is exhausted. If not it could give incorrect indication and lead to a hazardous situation.
Insulating material for tubes and rods of <i>phase comparator</i> as complete device	The good dielectric performance of the insulating material for tubes and rods used for complete devices guarantees the protection of the worker during each use of the device.
<i>Protection against bridging</i>	This would be hazardous for the user to have the <i>phase comparator</i> initiate a fault between two parts at different potential. Of course the users would not be in the direct circuit of the arc but may be close enough to suffer from the arc by-products.
<i>Indicator casing</i>	If the material and dimensioning of the <i>indicator casing</i> are not adequately rated with respect to voltage and power, it can lead to hazardous situation.
Marking – correctness	An incorrect marking, for example a wrong <i>nominal voltage</i> or a wrong operational class, could result in a hazardous situation.



Requirement	Justification for the associated defect specified in Annex D
<b>Critical defects (cont.)</b>	
Vibration resistance	If a brand new device does not have a good mechanical performance to drop, shock and vibration, it can lead to internal defect which can cause hazardous situations.
Drop resistance	
Shock resistance	
<b>Major defects</b>	
<i>Clear perceptibility</i> : only visual	If the worker cannot see the visual indication, the worker cannot conclude.
<i>Testing element</i> (non-functioning)	If the <i>testing element</i> does not function, the worker will become aware of that during the test. This results in a non-availability of the <i>phase comparator</i> .
Instructions for use	A <i>phase comparator</i> without its instructions for use is an incomplete product and should not be used.
Time rating	If a <i>phase comparator</i> does not respect the time rating, it means that an internal fault has occurred. The device does not work properly any more. That reduces significantly the functionality of the product.
Protection against sparking	If a <i>phase comparator</i> does not respect this requirement, some elements could be destroyed. The device does not work anymore. That reduces significantly the functionality of the product.
Distance range	A wireless <i>phase comparator</i> that cannot communicate properly within its specified distance range is not functional.
Marking: availability and durability	If the marking is not available or is impaired the worker will not use the <i>phase comparator</i> .
<b>Minor defects</b>	
Electromagnetic – emission	If the <i>phase comparator</i> does not fulfil the emission requirements, it will (perhaps) affect other devices in the vicinity but it will not affect the <i>phase comparator</i> .
<i>Clear perceptibility</i> : visual and audible	We can consider that there is always one <i>active signal</i> operational and the operator can conclude. It does not affect significantly the functionality of the device.
<i>Response time</i> only for <i>phase comparators</i> with one <i>active signal</i> “incorrect phase relationship” or “correct phase relationship” and with a declared <i>response time</i> above 1 s or with two <i>active signals</i>	For these types of <i>phase comparator</i> , a “non response” can never be considered as an indication. The worker will conclude something only when the device gives an indication, even if he has to wait more than 1 s. There is no misunderstanding.
Grip force and deflection	Even if the grip force and the deflection do not fulfil the requirements, it does not reduce significantly the functionality of the product.

## Annex G (informative)

### In-service care

*Maintenance tests* should be carried out periodically on *phase comparators* to ascertain and, if necessary, make certain adjustments to ensure that their performance remains within specified limits.

It is the responsibility of the user to elaborate the maintenance schedule, based on national regulations, on manufacturer's instructions and on the conditions of use (storage, regular care, etc.). However, no *phase comparator*, even those held in storage, should be used unless re-tested, within a maximum period of six years.

It is recommended that the periodic maintenance be done by a competent test facility.

At any time, a visual inspection of the *phase comparator* should be made before use. If there is a doubt that the device is not in good condition, it should be excluded from further use, then returned to the manufacturer for repair or rejection.

Table G.1 lists the tests that verify the physical integrity, the functioning of the *phase comparator* and its insulation performance. It also recommends a chronological order for performing the tests. The *insulating stick* to be used with *phase comparators* as a separate device should be covered by an IEC, regional, national or local/company standard.

**Table G.1 – In-service testing**

Chronological order	Designations	Subclauses
1	Visual and dimensional inspection	5.4.1
2	Check of <i>testing element</i> <sup>a</sup>	5.2.10.2
3	Leakage current under dry conditions <sup>b</sup>	5.3.5.2
4	<i>Protection against bridging for indoor/outdoor type phase comparator</i> <sup>c</sup>	5.3.2
5	Spark resistance <sup>d</sup>	5.3.4
6	<i>Clear indication</i>	5.2.2
7	<i>Clear perceptibility</i> of visual indication <sup>e</sup>	5.2.6.1
7	<i>Clear perceptibility</i> of audible indication <sup>e</sup>	5.2.6.2

a The check of the electrical circuits, to verify that all circuits are tested, is not necessary.

b When the test is performed as a periodic testing, the admissible leakage current may be higher than that specified in 5.3.5 but it should not exceed 200  $\mu$ A.

c Under dry conditions only.

d For practical purposes this test may be combined with the test for *protection against bridging* (number 5 of the chronological list). The test duration for spark resistance is at least 5 s.

e A comparison may be made with a reference *phase comparator* of the same design. Tests for *clear perceptibility* may also be combined with other previous tests of the list.

According to the design of the *phase comparator* and its fabrication process, the manufacturer may specify additional tests related to particular components or characteristics. These specific tests should be noted in the instructions for use.

## Bibliography

IEC 60050 (all parts), *International Electrotechnical Vocabulary* (available at <http://www.electropedia.org>)

IEC 60050-651:2014, *International Electrotechnical Vocabulary (IEV) – Part 651: Live working*

IEC 60071-1:2006, *Insulation co-ordination – Part 1: Definitions, principles and rules*

IEC 60743:2013, *Live working – Terminology for tools, equipment and devices*

IEC 60855-1:2009, *Live working – Insulating foam-filled tubes and solid rods – Part 1: Tubes and rods of a circular cross-section*

IEC 61235:1993, *Live working – Insulating hollow tubes for electrical purposes*

IEC 61936-1:2010, *Power installations exceeding 1 kV a.c. – Part 1: Common rules*

ISO/IEC 17025, *General requirements for the competence of testing and calibration laboratories*

---





# British Standards Institution (BSI)

BSI is the national body responsible for preparing British Standards and other standards-related publications, information and services.

BSI is incorporated by Royal Charter. British Standards and other standardization products are published by BSI Standards Limited.

## About us

We bring together business, industry, government, consumers, innovators and others to shape their combined experience and expertise into standards-based solutions.

The knowledge embodied in our standards has been carefully assembled in a dependable format and refined through our open consultation process. Organizations of all sizes and across all sectors choose standards to help them achieve their goals.

## Information on standards

We can provide you with the knowledge that your organization needs to succeed. Find out more about British Standards by visiting our website at [bsigroup.com/standards](http://bsigroup.com/standards) or contacting our Customer Services team or Knowledge Centre.

## Buying standards

You can buy and download PDF versions of BSI publications, including British and adopted European and international standards, through our website at [bsigroup.com/shop](http://bsigroup.com/shop), where hard copies can also be purchased.

If you need international and foreign standards from other Standards Development Organizations, hard copies can be ordered from our Customer Services team.

## Subscriptions

Our range of subscription services are designed to make using standards easier for you. For further information on our subscription products go to [bsigroup.com/subscriptions](http://bsigroup.com/subscriptions).

With **British Standards Online (BSOL)** you'll have instant access to over 55,000 British and adopted European and international standards from your desktop. It's available 24/7 and is refreshed daily so you'll always be up to date.

You can keep in touch with standards developments and receive substantial discounts on the purchase price of standards, both in single copy and subscription format, by becoming a **BSI Subscribing Member**.

**PLUS** is an updating service exclusive to BSI Subscribing Members. You will automatically receive the latest hard copy of your standards when they're revised or replaced.

To find out more about becoming a BSI Subscribing Member and the benefits of membership, please visit [bsigroup.com/shop](http://bsigroup.com/shop).

With a **Multi-User Network Licence (MUNL)** you are able to host standards publications on your intranet. Licences can cover as few or as many users as you wish. With updates supplied as soon as they're available, you can be sure your documentation is current. For further information, email [bsmusales@bsigroup.com](mailto:bsmusales@bsigroup.com).

## BSI Group Headquarters

389 Chiswick High Road London W4 4AL UK

## Revisions

Our British Standards and other publications are updated by amendment or revision.

We continually improve the quality of our products and services to benefit your business. If you find an inaccuracy or ambiguity within a British Standard or other BSI publication please inform the Knowledge Centre.

## Copyright

All the data, software and documentation set out in all British Standards and other BSI publications are the property of and copyrighted by BSI, or some person or entity that owns copyright in the information used (such as the international standardization bodies) and has formally licensed such information to BSI for commercial publication and use. Except as permitted under the Copyright, Designs and Patents Act 1988 no extract may be reproduced, stored in a retrieval system or transmitted in any form or by any means – electronic, photocopying, recording or otherwise – without prior written permission from BSI. Details and advice can be obtained from the Copyright & Licensing Department.

## Useful Contacts:

### Customer Services

**Tel:** +44 845 086 9001

**Email (orders):** [orders@bsigroup.com](mailto:orders@bsigroup.com)

**Email (enquiries):** [cservices@bsigroup.com](mailto:cservices@bsigroup.com)

### Subscriptions

**Tel:** +44 845 086 9001

**Email:** [subscriptions@bsigroup.com](mailto:subscriptions@bsigroup.com)

### Knowledge Centre

**Tel:** +44 20 8996 7004

**Email:** [knowledgecentre@bsigroup.com](mailto:knowledgecentre@bsigroup.com)

### Copyright & Licensing

**Tel:** +44 20 8996 7070

**Email:** [copyright@bsigroup.com](mailto:copyright@bsigroup.com)



...making excellence a habit.™