

# Conduit systems for cable management —

## Part 1: General requirements

ICS 29.120.10

## National foreword

This British Standard is the UK implementation of EN 61386-1:2008. It is identical to IEC 61386-1:2008. It supersedes BS EN 61386-1:2004, which will be withdrawn on 1 June 2011.

The UK participation in its preparation was entrusted to Technical Committee PEL/213, Cable management.

A list of organizations represented on this committee can be obtained on request to its secretary.

This publication does not purport to include all the necessary provisions of a contract. Users are responsible for its correct application.

**Compliance with a British Standard cannot confer immunity from legal obligations.**

This British Standard was published under the authority of the Standards Policy and Strategy Committee on 30 September 2008

© BSI 2008

ISBN 978 0 580 56408 6

### Amendments/corrigenda issued since publication

Date	Comments

English version

**Conduit systems for cable management -  
Part 1: General requirements  
(IEC 61386-1:2008)**

Systèmes de conduits  
pour la gestion du câblage -  
Partie 1: Exigences générales  
(CEI 61386-1:2008)

Elektroinstallationsrohrsysteme  
für elektrische Energie  
und für Informationen -  
Teil 1: Allgemeine Anforderungen  
(IEC 61386-1:2008)

This European Standard was approved by CENELEC on 2008-06-01. CENELEC members are bound to comply with the CEN/CENELEC Internal Regulations which stipulate the conditions for giving this European Standard the status of a national standard without any alteration.

Up-to-date lists and bibliographical references concerning such national standards may be obtained on application to the Central Secretariat or to any CENELEC member.

This European Standard exists in three official versions (English, French, German). A version in any other language made by translation under the responsibility of a CENELEC member into its own language and notified to the Central Secretariat has the same status as the official versions.

CENELEC members are the national electrotechnical committees of Austria, Belgium, Bulgaria, Cyprus, the Czech Republic, Denmark, Estonia, Finland, France, Germany, Greece, Hungary, Iceland, Ireland, Italy, Latvia, Lithuania, Luxembourg, Malta, the Netherlands, Norway, Poland, Portugal, Romania, Slovakia, Slovenia, Spain, Sweden, Switzerland and the United Kingdom.

**CENELEC**

European Committee for Electrotechnical Standardization  
Comité Européen de Normalisation Electrotechnique  
Europäisches Komitee für Elektrotechnische Normung

**Central Secretariat: rue de Stassart 35, B - 1050 Brussels**

## Foreword

The text of document 23A/553/FDIS, future edition 2 of IEC 61386-1, prepared by SC 23A, Cable management systems, of IEC TC 23, Electrical accessories, was submitted to the IEC-CENELEC parallel vote and was approved by CENELEC as EN 61386-1 on 2008-06-01.

This European Standard supersedes EN 61386-1:2004 + corrigendum April 2004.

The changes to EN 61386-1:2004 are as follows:

- change to the length of the test specimen between fittings for the tensile test,
- editorial and normative reference updates.

The following dates were fixed:

- latest date by which the EN has to be implemented at national level by publication of an identical national standard or by endorsement (dop) 2009-03-01
- latest date by which the national standards conflicting with the EN have to be withdrawn (dow) 2011-06-01

This Part 1 is to be used in conjunction with the appropriate Part 2, which contains clauses to supplement or modify the corresponding clauses in Part 1, to provide the relevant particular requirements for each type of product. A conduit system which conforms to this standard is deemed safe for use.

In this publication, the following print types are used:

- Requirements proper: in roman type.
- *Test specifications: in italic type.*
- Explanatory matter: in smaller roman type.

For this European Standard the references to Austria and Australia in Subclauses 6.5.2 and 13.1.4 of IEC 61386-1:2008 shall be disregarded and have been replaced by the normative Annex ZB, *Special national conditions*.

Annexes ZA and ZB have been added by CENELEC.

---

## Endorsement notice

The text of the International Standard IEC 61386-1:2008 was approved by CENELEC as a European Standard without any modification.

---

## CONTENTS

1	Scope.....	5
2	Normative references .....	5
3	Terms and definitions .....	5
4	General requirements.....	7
5	General conditions for tests.....	7
6	Classification.....	8
6.1	According to mechanical properties .....	8
6.1.1	Resistance to compression.....	8
6.1.2	Resistance to impact .....	8
6.1.3	Resistance to bending .....	9
6.1.4	Tensile strength.....	9
6.1.5	Suspended load capacity.....	9
6.2	According to temperature .....	9
6.2.1	Lower temperature range.....	9
6.2.2	Upper temperature range.....	10
6.3	According to electrical characteristics.....	10
6.3.1	With electrical continuity characteristics .....	10
6.3.2	With electrical insulating characteristics .....	10
6.3.3	With electrical continuity and insulating characteristics.....	10
6.4	According to resistance to external influences .....	10
6.4.1	Protection against ingress of solid objects: protection in accordance with IEC 60529 to a minimum of IP3X.....	10
6.4.2	Protection against ingress of water: protection in accordance with IEC 60529 to a minimum of IPX0 .....	10
6.4.3	Resistance against corrosion.....	10
6.5	According to resistance to flame propagation .....	10
6.5.1	Non-flame propagating .....	10
6.5.2	Flame propagating.....	10
7	Marking and documentation.....	10
8	Dimensions .....	11
9	Construction.....	11
10	Mechanical properties .....	13
10.1	Mechanical strength .....	13
10.2	Compression test .....	14
10.3	Impact test .....	14
10.4	Bending test.....	15
10.5	Flexing test .....	15
10.6	Collapse test.....	15
10.7	Tensile test .....	15
10.8	Suspended load test.....	16
11	Electrical properties.....	17
11.1	Electrical requirements.....	17
11.2	Bonding test.....	17
11.3	Dielectric strength and insulation resistance.....	18

12	Thermal properties .....	19
13	Fire hazard.....	20
13.1	Reaction to fire.....	20
13.1.1	Initiation of fire .....	20
13.1.2	Contribution to fire.....	20
13.1.3	Spread of fire .....	20
13.1.4	Additional reaction to fire characteristics .....	22
13.2	Resistance to fire .....	22
14	External influences .....	22
14.1	Degree of protection provided by enclosure.....	22
14.1.1	General .....	22
14.1.2	Degree of protection – Ingress of foreign solid objects.....	22
14.1.3	Degree of protection – Ingress of water .....	22
14.2	Resistance against corrosion.....	23
15	Electromagnetic compatibility .....	24
	Annex A (normative) Classification coding for conduit systems .....	32
	Annex B (normative) Determination of material thickness.....	35
	Annex ZA (normative) Normative references to international publications with their corresponding European publications.....	38
	Annex ZB (normative) Special national conditions.....	39
	Bibliography.....	37
	Figure 1 – Arrangement for compression test.....	25
	Figure 2 – Impact test apparatus.....	25
	Figure 3 – Assembly of conduit and conduit fitting for bonding test .....	26
	Figure 4 – Arrangement for dielectric strength and insulation resistance tests – Rigid conduit.....	27
	Figure 5 – Arrangement for dielectric strength and insulation resistance tests – Pliable and flexible conduit.....	28
	Figure 6 – Steel enclosure for test for resistance to flame propagation .....	29
	Figure 7 – Test arrangement for resistance to flame propagation .....	30
	Figure 8 – Test apparatus for resistance to heat .....	31
	Table 1 – Lower temperature range .....	9
	Table 2 – Upper temperature range .....	10
	Table 3 – Torque values for screw tests.....	13
	Table 4 – Compression force .....	14
	Table 5 – Impact test values .....	15
	Table 6 – Tensile force .....	16
	Table 7 – Suspended load .....	17
	Table 8 – Load for heating test .....	19
	Table 9 – Times of exposure of the sample to the flame .....	21
	Table 10 – Resistance to corrosion classification .....	23

## CONDUIT SYSTEMS FOR CABLE MANAGEMENT –

### Part 1: General requirements

#### 1 Scope

This part of IEC 61386 specifies requirements and tests for conduit systems, including conduits and conduit fittings, for the protection and management of insulated conductors and/or cables in electrical installations or in communication systems up to 1 000 V a.c. and/or 1 500 V d.c. This standard applies to metallic, non-metallic and composite conduit systems, including threaded and non-threaded entries which terminate the system. This standard does not apply to enclosures and connecting boxes which come within the scope of IEC 60670.

NOTE 1 Certain conduit systems may also be suitable for use in hazardous atmospheres. Regard should then be taken of the extra requirements necessary for equipment to be installed in such conditions.

NOTE 2 Earthing conductors may or may not be insulated.

#### 2 Normative references

The following referenced documents are indispensable for the application of this document. For dated references, only the edition cited applies. For undated references, the latest edition of the referenced document (including any amendments) applies.

IEC 60417, *Graphical symbols for use on equipment*

IEC 60423:2007, *Conduit systems for cable management – Outside diameters of conduits for electrical installations and threads for conduits and fittings*

IEC 60529:1989, *Degrees of protection provided by enclosures (IP Code)*  
Amendment 1 (1999)

IEC 60695-2-11:2000, *Fire hazard testing – Part 2-11: Glowing/hot-wire based test methods - Glow-wire flammability test method for end-products*

IEC 60695-11-2:2003, *Fire hazard testing – Part 11-2: Test flames - 1 kW nominal pre-mixed flame - Apparatus, confirmatory test arrangement and guidance*

#### 3 Terms and definitions

For the purposes of this document, the following definitions apply:

##### 3.1

##### **conduit system**

cable management system consisting of conduits and conduit fittings for the protection and management of insulated conductors and/or cables in electrical or communication installations, allowing them to be drawn in and/or replaced, but not to be inserted laterally

**3.2****conduit**

part of conduit system of circular cross-section for insulated conductors and/or cables in electrical or communication installations, allowing them to be drawn in and/or replaced

**3.3****conduit fitting**

device designed to join components of a conduit system, or for them to change direction

**3.4****terminating conduit fitting**

conduit fitting that terminates a conduit system

**3.5****metallic conduit and/or conduit fitting**

conduit or conduit fitting which consists of metal only

**3.6****non-metallic conduit and/or conduit fitting**

conduit or conduit fitting which consists uniquely of non-metallic material and which has no metallic components whatsoever

**3.7****composite conduit and/or conduit fitting**

conduit or conduit fitting comprising both metallic and non-metallic materials

**3.8****non-flame propagating conduit and/or conduit fitting**

conduit or conduit fitting which is liable to catch fire as a result of an applied flame, but in which the flame does not propagate, and which extinguishes itself within a limited time after the flame is removed

**3.9****plain conduit**

conduit in which the profile is even in the longitudinal section (see note to 3.10)

**3.10****corrugated conduit**

conduit in which the profile is corrugated in the longitudinal section

NOTE Both annular and helical corrugated conduits are permissible, and a combination of both corrugated and plain conduit is possible.

**3.11****rigid conduit**

conduit which cannot be bent, or which can only be bent with the help of a mechanical aid, with or without special treatment

**3.12****pliable conduit**

conduit which can be bent by hand with reasonable force, and which is not intended for frequent flexing

**3.13****flexible conduit**

conduit which can be bent by hand with reasonable small force, and which is intended to flex frequently throughout its life



**3.14****self-recovering conduit**

pliable conduit which deforms when a transverse force is applied for a short time and which, after removal of this force, returns close to its original shape within a further short time

**3.15****threadable conduit and conduit fitting**

conduit and conduit fittings which carry a thread for connection, or in or on which a thread can be formed

**3.16****non-threadable conduit and conduit fitting**

conduit and conduit fittings which are suitable for connection only by means other than threads

**3.17****external influence**

factors which may affect the conduit system

NOTE Examples of such factors are a presence of water, oil or building materials, low and high temperatures, and corrosive or polluting substances.

**4 General requirements**

**4.1** Conduit and conduit fittings shall be so designed and constructed that in normal use their performance is reliable and they provide protection to the user or surroundings.

When assembled in accordance with manufacturer's instructions as part of a conduit system, conduits and conduit fittings shall provide mechanical and, where required, electrical protection of the insulated conductors and cables contained therein.

**4.2** The protective properties of the joint between the conduit and conduit fitting shall not be less than that declared for the conduit system.

**4.3** Conduit and conduit fittings shall withstand the stresses likely to occur during transport, storage, recommended installation practice and application.

**4.4** Compliance is checked by carrying out all specified tests.

**5 General conditions for tests**

**5.1** Tests in accordance with this standard are type tests. Conduit systems, having the same classification, which can vary in colour only, shall be the same product type.

**5.2** Unless otherwise specified, the tests shall be carried out at an ambient temperature of  $(20 \pm 5) ^\circ\text{C}$ .

**5.3** Unless otherwise specified, each test shall be made on three new samples, which may be taken from one length.

NOTE Certain tests, for instance the checking of dimensions, do not affect a change in the property of the samples; therefore these samples are considered as new samples and can be used for further tests.

**5.4** Samples of non-metallic and composite conduits and conduit fittings shall be conditioned for at least 240 h, at a temperature of  $(23 \pm 2)$  °C and a relative humidity between 40 % and 60 %. All tests shall be carried out immediately after general conditioning.

**5.5** Unless otherwise specified, the samples for each test shall be in a clean and new condition, with all parts in place and mounted as in normal use. After checking dimensions in accordance with Clause 8, and unless otherwise specified in the relevant test, the conduit fittings shall be assembled with adequate lengths of conduit of the type for which they are intended. Due regard shall be taken of the manufacturer's instructions, especially where force is required in the assembly of the joint.

NOTE Where similarities are claimed, the selection of representative fittings for test purposes can be agreed between the manufacturer, or responsible vendor, and the testing station.

**5.6** Where the conduit entries are part of the detachable or loose type conduit fitting, the detachable conduit fitting shall be capable of being assembled again, after the test, according to the manufacturer's instructions without loss of the declared properties according to Clause 6.

**5.7** Unless otherwise specified, three samples are subjected to the tests, and the requirements are satisfied if the tests are met.

If only one of the samples does not satisfy a test, due to an assembly or a manufacturing defect, that test and any preceding one which may have influenced the result of the test shall be repeated, and also the tests which follow shall be carried out in the required sequence on another full set of samples, all of which shall comply with the requirements.

NOTE If the additional set of samples is not submitted at the same time, a failure of one sample will entail a rejection. The applicant, when submitting the first set of samples, may also submit an additional set of samples which may be used, should one sample fail. The testing station will then, without further request, test the additional set of samples and will reject them only if a further failure occurs.

**5.8** When toxic or hazardous processes are used, due regard shall be taken of the safety of the persons within the test area.

**5.9** Conduit systems which are used as an integral part of other equipment shall also be tested in accordance with the relevant standard for that equipment.

## **6 Classification**

NOTE Annex A shows the classification coding format for declared properties of the conduit system, which may be incorporated in the manufacturer's literature.

### **6.1 According to mechanical properties**

#### **6.1.1 Resistance to compression**

- 1 Very light
- 2 Light
- 3 Medium
- 4 Heavy
- 5 Very heavy

#### **6.1.2 Resistance to impact**

- 1 Very light
- 2 Light
- 3 Medium

- 4 Heavy
- 5 Very heavy

**6.1.3 Resistance to bending**

- 1 Rigid
- 2 Pliable
- 3 Pliable/Self-recovering
- 4 Flexible

**6.1.4 Tensile strength**

- 1 Very light
- 2 Light
- 3 Medium
- 4 Heavy
- 5 Very heavy

**6.1.5 Suspended load capacity**

- 1 Very light
- 2 Light
- 3 Medium
- 4 Heavy
- 5 Very heavy

**6.2 According to temperature**

**6.2.1 Lower temperature range**

**Table 1 – Lower temperature range**

Classification	Transport, installation and application – Temperature not less than: °C
1	+ 5
2	– 5
3	– 15
4	– 25
5	– 45

**6.2.2 Upper temperature range****Table 2 – Upper temperature range**

<b>Classification</b>	<b>Application and installation – Temperature not more than: °C</b>
1	60
2	90
3	105
4	120
5	150
6	250
7	400

**6.3 According to electrical characteristics****6.3.1 With electrical continuity characteristics****6.3.2 With electrical insulating characteristics****6.3.3 With electrical continuity and insulating characteristics****6.4 According to resistance to external influences****6.4.1 Protection against ingress of solid objects: protection in accordance with IEC 60529 to a minimum of IP3X****6.4.2 Protection against ingress of water: protection in accordance with IEC 60529 to a minimum of IPX0****6.4.3 Resistance against corrosion****6.4.3.1 Without protection****6.4.3.2 With protection as detailed in Table 10****6.5 According to resistance to flame propagation****6.5.1 Non-flame propagating****6.5.2 Flame propagating**

In Australia and Austria, conduits and conduit fittings may be classified with low acid gas emission.

**7 Marking and documentation****7.1 Each conduit shall be marked with**

- the manufacturer's or responsible vendor's name or trade mark or identification mark,
- a product identification mark, which may be, for example, a catalogue number, a symbol or the like, in such a way that it can be identified in the manufacturer's or responsible vendor's literature.

**7.1.1** The conduit may also be marked with the classification code, which shall be in accordance with Annex A, and which shall include at least the first four digits.

**7.1.2** The manufacturer shall be responsible for indicating the compatibility of parts within a conduit system.

**7.1.3** The manufacturer shall provide in his literature its classification in accordance with Clause 6 and all information necessary for the proper and safe transport, storage, installation and use.

**7.2** The conduit fitting shall be marked in accordance with 7.1, on the product wherever possible, but, where this is impractical, then the mark may be on a label attached to the product, or on the smallest supplied package.

**7.3** Flame propagating material shall be orange in colour. It shall not be coloured orange by painting or other superficial means.

Non-flame propagating material may be of any colour except yellow, orange or red, unless clearly marked on the product to be of non-flame propagating material.

**7.4** Earthing facilities shall be indicated by the symbol for protective earth in accordance with IEC 60417, symbol IEC 60417-5019 (2006-08). This marking shall not be placed on easily removable parts, for example screws.

**7.5** Compliance with 7.1 to 7.4 is checked by inspection.

**7.6** The marking shall be durable and clearly legible.

*Compliance is checked by inspection and by rubbing the marking by hand for 15 s with a piece of cloth soaked with water, and again for 15 s with a piece of cloth soaked with petroleum spirit.*

NOTE 1 Petroleum spirit is defined as the aliphatic solvent hexane with a content of aromatics of maximum 0,1% volume, a kauri-butanol value of 29, initial boiling point 65 °C, a dry point 69 °C, and density of approximately 0,68 g/cm<sup>3</sup>.

NOTE 2 Marking may be applied, for example, by moulding, pressing, engraving, printing, adhesive labels, or water slide transfers.

NOTE 3 Marking made by moulding, pressing or engraving is not subjected to this test.

*After the test, the marking shall be legible.*

## **8 Dimensions**

**8.1** Threads and outside diameters, where appropriate, shall comply with IEC 60423.

*Compliance is checked by means of the gauges specified in IEC 60423.*

**8.2** Other dimensions shall comply with the requirements of the relevant Part 2 of IEC 61386.

## **9 Construction**

**9.1** Within the conduit system, there shall be no sharp edges, burrs or surface projections which are likely to damage insulated conductors or cables, or inflict injury on the installer or user.

*Compliance is checked by inspection, if necessary after cutting the samples apart.*

**9.2** Screws, if any, used for attaching components or covers to conduit fittings, or in joints to conduits, shall not cause damage to cable insulation when correctly inserted. They shall have ISO metric threads. Thread-cutting screws shall not be used.

Fixing screws and small clips for use with non-metallic or composite conduit fittings need not be of non-metallic material if they are isolated from insulated conductors or cables.

Screw fixing means shall be so designed to withstand the mechanical stresses occurring during installation and normal use.

*Compliance for screw fixing using preformed threads is checked by the test in 9.3, followed by inspection.*

*Compliance for screw fixing using thread-forming screws is checked by the test in 9.4, followed by inspection.*

**9.3** *Screws used with preformed threads shall be tightened and loosened 10 times for screws in engagement with a thread of non-metallic material and for screws of non-metallic material, and five times in all other cases.*

*The test is carried out using a suitable screwdriver or spanner to apply a torque, as specified by the manufacturer. In case the manufacturer does not specify the torque, the values of Table 3 apply. The screws shall be tightened in one smooth and continuous motion.*

*After the test, there shall be no damage sustained by the screw or nut, such as breakage of the screw or damage to the head or thread, that will impair the further use of the screw or nut.*

**9.4** *Thread-forming screws are tightened and loosened 10 times for screws in engagement with a thread of insulating material, and five times in all other cases. Screws in engagement with a thread of insulating material shall be completely removed each time.*

*The test is made by using a suitable screwdriver or spanner applying with the relevant torque given in Table 3. The screw shall not be tightened by sudden or jerky motions.*

*After the test, there shall be no damage such as breakage of the screw or damage to the head or thread, that will impair the further use of the screw.*

Table 3 – Torque values for screw tests

Nominal diameter of thread mm		Torque Nm	
Over	Up to and including	I <sup>a</sup>	II <sup>b</sup>
–	2,8	0,4	0,4
2,8	3,0	0,5	0,5
3,0	3,2	0,6	0,6
3,2	3,6	0,8	0,8
3,6	4,1	1,2	1,2
4,1	4,7	1,8	1,8
4,7	5,3	2,0	2,0
5,3	6,0	2,5	3,0
6,0	8,0	3,5	6,0
8,0	10,0	4,0	10,0

<sup>a</sup> Column I applies to screws which are tightened by means of a screwdriver.

<sup>b</sup> Column II applies to screws and nuts which are tightened by means other than a screwdriver.

**9.5** Any material, for example rubber, fibre etc., within the joint, which may be exposed to external influences when assembled according to the manufacturer's instructions, shall have at least the same level of resistance to the external influence as either the conduit or the conduit fitting.

*Compliance is checked by means of tests specified in Clause 14.*

**9.6** For conduit systems that are assembled by means other than threads, the manufacturer shall indicate whether the system can be disassembled and if so, how this can be achieved.

*Compliance is checked by inspection and by manual test.*

## 10 Mechanical properties

### 10.1 Mechanical strength

**10.1.1** Conduit systems shall have adequate mechanical strength.

**10.1.2** Conduits, according to their classification, when bent or compressed, or exposed to impact or extreme temperature of a specified value in accordance with impact and temperature classification declared for the product, either during, or after installation according to the manufacturer's instructions, shall not crack and shall not be deformed to such an extent that introduction of the insulated conductors or cables becomes difficult, or that the installed insulated conductors or cables are likely to be damaged while being drawn in.

**10.1.3** Conduit systems intended as a mounting for other equipment shall have adequate mechanical strength to support such equipment and to withstand the force required to operate the equipment, both during and after installation.

**10.1.4** *Compliance of 10.1.1 to 10.1.3 is checked by the tests specified in 10.2 to 10.8.*

## 10.2 Compression test

**10.2.1** Samples of conduit, each  $(200 \pm 5)$  mm long, shall be subjected to a compression test at  $(23 \pm 2)$  °C, using the apparatus shown in Figure 1.

**10.2.2** Before the test, the outside diameters of the samples shall be measured.

**10.2.3** The samples shall be positioned on a flat steel support, and a steel intermediate piece, as shown in Figure 1, shall be placed in the middle of the sample.

**10.2.4** A uniformly increasing compression force, reaching the values shown in Table 4 within  $(30 \pm 3)$  s, shall be applied to the intermediate piece.

**10.2.5** After the force given in Table 4 has been applied for  $(60 \pm 2)$  s, the outside diameter of the sample shall be measured where flattening has taken place, without removing the force.

**Table 4 – Compression force**

Classification	Conduits	Compression force
		Tolerance $^{+4}_{0}$ % N
1	Very light	125
2	Light	320
3	Medium	750
4	Heavy	1250
5	Very heavy	4000

**10.2.6** The difference between the initial outside diameter and the diameter of the flattened sample shall not exceed 25 % of the initial outside diameter measured before the test.

**10.2.7** The force and the intermediate piece are then removed and,  $(60 \pm 2)$  s after removal, the outside diameter of the samples, where they have flattened, shall be measured again.

The difference between the initial diameter and the diameter of the flattened samples shall not exceed 10 % of the outside diameter, measured before the test.

**10.2.8** After the test, the samples shall show no cracks visible to normal or corrected vision without additional magnification.

## 10.3 Impact test

**10.3.1** Twelve samples of conduit each  $(200 \pm 5)$  mm in length, or twelve conduit fittings are subjected to an impact test by means of the apparatus shown in Figure 2.

Before the test, the samples are assembled with all the components as for normal use, including conduits required for conducting of the test.

NOTE Conduit fittings are not required when testing conduits.



Parts, which are not accessible when mounted in normal use, and small conduit fittings whose maximum dimension is less than 20 mm, are not subjected to this test.

**10.3.2** *The test apparatus, together with the samples, shall be placed in a refrigerator, the temperature within which shall be maintained at the declared temperature as given in Table 1 with a tolerance of  $\pm 2$  °C.*

*When the samples have attained the temperature specified, or after 2 h, whichever is the longer period, each sample shall be placed in position on the steel base as shown in Figure 2. The hammer shall be allowed to fall once on each sample. The mass of the hammer and the fall height shall be as given in Table 5.*

*The test shall be made on the weakest part of the conduit fitting, except that it shall not be applied to within 5 mm of any conduit entry. Samples of conduit are tested at the centre of their length.*

**Table 5 – Impact test values**

Classification	Conduit and fittings	Mass of hammer	Fall height
		Tolerance $^{+1}_{0}$ % kg	Tolerance $\pm 1$ % mm
1	Very light	0,5	100
2	Light	1,0	100
3	Medium	2,0	100
4	Heavy	2,0	300
5	Very heavy	6,8	300

**10.3.3** *After the test, when samples have attained  $(20 \pm 5)$  °C, it shall be possible to pass the appropriate gauge specified in the relevant particular requirements (Parts 21, 22, 23, etc.) through the conduit, under its own weight and without any initial speed, with the sample in the vertical position. There shall be no sign of disintegration nor shall there be any crack visible to normal or corrected vision without magnification.*

*At least nine of the twelve samples shall pass the test.*

#### **10.4 Bending test**

*The test is specified in the relevant particular requirements (Parts 21, 22, 23, etc.) of IEC 61386.*

#### **10.5 Flexing test**

*The test is specified in the relevant particular requirements (Parts 21, 22, 23, etc.) of IEC 61386.*

#### **10.6 Collapse test**

*The test is specified in the relevant particular requirements (Parts 21, 22, 23, etc.) of IEC 61386.*

#### **10.7 Tensile test**

**10.7.1** *Conduit systems declaring tensile strength shall be tested as follows:*

A sample of conduit and two conduit fittings or terminating conduit fittings are assembled in accordance with the manufacturer's instructions so that the length of the conduit between the fittings is at least 200 mm. Where this is impractical, the test shall be carried out on two samples of conduits and a conduit fitting. The assembly is subjected to a uniformly increasing tensile force reaching the value given in Table 6, at  $(23 \pm 2)$  °C, in  $(30 \pm 3)$  s. This tensile force is then maintained for  $2 \text{ min} \pm 10 \text{ s}$ .

**10.7.2** Where elongation occurs, the manufacturer shall be responsible for providing guidelines to assist the safe installation of the conduit system.

**10.7.3** For conduit systems where tensile strength is not declared, the tensile strength of the joint shall meet the requirements of the relevant tests of the appropriate Part 2.

**10.7.4** After the test, the conduit fittings or terminating conduit fittings shall remain properly assembled to the conduit, and there shall be no damage visible to normal or corrected vision without magnification.

**Table 6 – Tensile force**

Classification	Conduit and fittings	Tensile force
		Tolerance $\begin{smallmatrix} +2 \\ 0 \end{smallmatrix}$ %
		N
1	Very light	100
2	Light	250
3	Medium	500
4	Heavy	1000
5	Very heavy	2500

## 10.8 Suspended load test

The conduit fitting, declared by the manufacturer to be suitable for suspended loads, is secured to a rigid structure using a method provided by the manufacturer, with the suspension means pointing downwards.

A load, with a time duration in accordance with Table 7, is suspended by the means provided, and installed in accordance with the manufacturer's instructions.

The fitting shall be deemed to have passed if at the end of the test, there are no cracks visible to normal or corrected vision without magnification, and there is no deformation of the conduit fitting impairing its normal use.

For non-metallic and composite conduit fittings, the test shall be carried out in a heating cabinet, the temperature within which is maintained at the declared maximum temperature given in Table 2 with a tolerance of  $\pm 2$  °C.

**Table 7 – Suspended load**

Classification	Fittings	Load	Duration
		Tolerance $^{+2}_0$ % N	Tolerance $^{+15}_0$ min h
1	Very light	20	48
2	Light	30	48
3	Medium	150	48
4	Heavy	450	48
5	Very heavy	850	48

## 11 Electrical properties

### 11.1 Electrical requirements

**11.1.1** Conduit systems declaring electrical continuity characteristics shall be checked by the test in 11.2 immediately after the test in 14.2.

NOTE Conduit systems, in some circumstances, may be used in total or in part as a protective conductor in an electrical installation. In that event, the system will be tested after final installation to confirm its suitability for that purpose, in accordance with the installation rules.

**11.1.2** Conduit systems of metal or composite materials shall be so constructed that accessible metal parts can be bonded to earth.

*Compliance is checked by inspection.*

**11.1.3** Accessible conductive parts of the metal or composite conduit system, which may become live in the event of a fault, shall be effectively earthed.

*Compliance is checked by the test in 11.2.*

**11.1.4** Conduit systems of non-metallic or composite materials, where declared, shall have an adequate electrical insulating strength and insulating resistance.

*Compliance is checked by the test in 11.3.*

### 11.2 Bonding test

*An arrangement of conduit and conduit fittings, consisting of 10 pieces of conduit, shall be coupled together, in accordance with the manufacturer's instructions and Figure 3, by means of conduit fittings representing, in approximately equal numbers, each type of fitting. The fittings shall be spaced between 100 mm and 150 mm apart. A current of 25 A, having a frequency of 50 Hz to 60 Hz derived from an a.c. source having a no-load voltage not exceeding 12 V, is passed through the assembly for  $(60 \pm 2)$  s. The voltage drop is then measured and the resistance calculated from the current and that voltage drop.*

*The resistance shall not exceed 0,1  $\Omega$ .*

*If the numbers of different types of fittings cannot all be accommodated in a single test, the test described above shall be repeated until all such different types of fittings have been tested.*

Where special devices are required for the coupling of conduit and conduit fittings, they shall be sufficient to remove the protective coating from the conduit, or the protective finish shall be removed in accordance with the manufacturer's instructions.

### 11.3 Dielectric strength and insulation resistance

#### 11.3.1 Conduits

**11.3.1.1** Samples of conduit are immersed over a length of  $1\text{ m} \pm 10\text{ mm}$  in accordance with Figure 4 or Figure 5 in a salt water solution at  $(23 \pm 2)^\circ\text{C}$ , with a length of 100 mm kept above the level of the solution.

Rigid conduit samples are to be supplied by the manufacturer complete with one end sealed with an appropriate insulating material with high electrical insulation, for example silicone elastomer; see Figure 4.

Pliable and flexible conduit samples are bent into a "U" shape and then immersed; see Figure 5.

The salt water solution is made by completely dissolving 1 g/l of sodium chloride.

The salt water solution is poured into the open end of the conduit to match the external level. An electrode is placed inside the conduit and another placed into the tank.

**11.3.1.2** After  $24\text{ h} \pm 15\text{ min}$ , a voltage is applied across the two electrodes, gradually being increased from 1 000 V to 2 000 V of substantially sine wave form and having a frequency of 50 Hz to 60 Hz. Having reached 2 000 V, the voltage is maintained for a period of  $15\text{ min}^{+5}_0\text{ s}$ .

The high-voltage transformer used for the test is so designed that, when the output terminals are short-circuited after the output voltage has been adjusted to the appropriate test voltage, the output current is of at least 200 mA. The overcurrent relay shall not trip when the output current is less than 100 mA. Care is taken that the r.m.s. value of the test voltage applied is measured within  $\pm 3\%$ .

The samples shall be considered to have adequate electrical insulating strength if a 100 mA trip device, incorporated into the circuit, does not trip during the 15 min test.

**11.3.1.3** Immediately after the test in 11.3.1.2, the same samples shall be subjected to an electrical insulation resistance test. A d.c. voltage of 500 V shall be applied across the two electrodes.

**11.3.1.4** After  $(60 \pm 2)\text{ s}$  from the application of the voltage, the insulation resistance between the electrodes shall be obtained. Conduits shall be considered to have adequate electrical insulation resistance if the measured resistance is greater than 100 M $\Omega$ .

#### 11.3.2 Conduit fittings

**11.3.2.1** Samples of conduit fittings shall be immersed for  $24\text{ h} \pm 15\text{ min}$ , in water at  $(23 \pm 2)^\circ\text{C}$ , and then thoroughly dried at room temperature.

**11.3.2.2** Conduit fitting samples shall be assembled in accordance with the manufacturer's instructions with a length of conduit not less than 100 mm. All other open ends are sealed with an appropriate insulating material. The inside of the fitting is filled with lead spheres of a diameter between 1,0 mm and 1,5 mm, and an electrode is inserted into the lead shot via the conduit.

An outer electrode of aluminium foil is wrapped around the outside of the fitting and compressed so that it follows the outer contour of the fitting as closely as possible.

**11.3.2.3** Conduit fitting samples shall be tested in accordance with 11.3.1.2 within 1 h of removal from the water.

**11.3.2.4** Immediately after the test in 11.3.2.3, the same samples are subjected to an electrical insulation resistance test. A d.c. voltage of 500 V is applied across the two electrodes.

**11.3.2.5** After  $(60 \pm 2)$  s from the application of the voltage, the insulation resistance between the electrodes is obtained. Fittings are considered to have adequate electrical insulation resistance if the resistance is greater than  $5 M\Omega$ .

## 12 Thermal properties

**12.1** Non-metallic and composite conduits shall have adequate resistance to heat.

Compliance is checked by the test in 12.2. and verified with 12.3 .

The load for the heating test shall be the same classification as the declared compression classification.

**12.2** Samples of conduit, each  $(100 \pm 5)$  mm long, together with the test apparatus as shown in Figure 8, shall be kept for  $4 h \pm 5 min$  in a heating cabinet at the declared temperature given in Table 2, with a tolerance of  $\pm 2$  °C.

After this period, each sample is loaded for  $24 h \pm 15 min$  in an apparatus, as shown in Figure 8, with an appropriate mass applied through a steel rod  $(6,0 \pm 0,1)$  mm in diameter, disposed at right angles to the axis of the conduit.

The sample is subjected to a total mass, including the mass of the rod, as shown in Table 8, placed in the middle of the sample.

The sample, under load, shall then be allowed to cool to room temperature.

**Table 8 – Load for heating test**

Classification to compression according to 6.1.1	Conduits	Mass
		Tolerance $^{+1}_0$ % kg
1	Very light	0,5
2	Light	1,0
3	Medium	2,0
4	Heavy	4,0
5	Very heavy	8,0

**12.3** The load is then removed, and immediately after its removal, it shall be possible to pass the appropriate gauge, specified in the relevant Part 2, through the conduit, under its own weight and without any initial speed, with the sample in the vertical position.

## 13 Fire hazard

### 13.1 Reaction to fire

#### 13.1.1 Initiation of fire

Not applicable.

NOTE Conduit systems are not in direct contact with live parts.

#### 13.1.2 Contribution to fire

Under consideration.

#### 13.1.3 Spread of fire

Non-flame propagating conduit systems shall have adequate resistance to flame propagation.

**13.1.3.1** *Compliance of non-metallic and composite conduit fittings is checked by using the glow-wire test in IEC 60695-2-11.*

*The glow wire shall be applied once to each sample in the most unfavourable position for its intended use (with the surface tested in a vertical position) at a temperature of 750 °C.*

*The sample is deemed to have passed this test if there is no visible flame or sustained glowing, or if flames or glowing extinguish within 30 s of the removal of the glow wire.*

**13.1.3.2** *Compliance of non-metallic and composite conduits is checked by applying a 1 kW flame, as specified in IEC 60695-11-2.*

**13.1.3.2.1** *A sample of length  $(675 \pm 10)$  mm is mounted vertically in a rectangular metal enclosure with one open face, as shown in Figure 6, in an area substantially free of draughts.*

*The general arrangement is shown in Figure 7.*

*Mounting is by means of two metal clamps approximately 25 mm wide, spaced  $(550 \pm 10)$  mm apart and approximately equidistant from the ends of the sample.*

*A steel rod of  $(2,0 \pm 0,1)$  mm for sizes up to 12 mm,  $(6,0 \pm 0,1)$  mm for sizes 16 mm to 25 mm and  $(16,0 \pm 0,1)$  mm for conduits with diameters 32 mm and above is passed through the sample. It is rigidly and independently mounted and clamped at the upper end to maintain the sample in a straight and vertical position. The means of mounting is such as not to obstruct drops from falling onto the tissue paper.*

*A suitable piece of white pine wood board, approximately 10 mm thick, covered with a single layer of white tissue paper, is positioned on the lower surface of the enclosure.*

*The assembly of sample, rod and clamping apparatus is mounted vertically in the centre of the enclosure, the upper extremity of the lower clamp being  $(500 \pm 10)$  mm above the internal lower surface of the enclosure.*

**13.1.3.2.2** *The burner is supported so that its axis is at an angle of  $(45 \pm 2)^\circ$  to the vertical.*

*The flame is applied to the sample so that the distance from the top of the burner tube to the sample, measured along the axis of the flame, is  $(100 \pm 10)$  mm, and the axis of the flame intersects with the surface of the sample at a point  $(100 \pm 5)$  mm from the upper extremity of the lower clamp, and so that the axis of the flame interacts with the axis of the sample.*

**13.1.3.2.3** *The flame is applied to the samples for the period given in Table 9, and is then removed. During the application of the flame, it shall not be moved, except to remove it at the end of the test period.*

*The determination of material thickness of plain conduit, corrugated conduit and combined plain conduit and corrugated conduit is given in Annex B. All three samples are measured and the mean material thickness is calculated for each sample. The highest mean value is used to determine the flame application time from Table 9.*

**Table 9 – Times of exposure of the sample to the flame**

Mean material thickness mm		Flame application time s  Tolerance $\begin{matrix} +1 \\ 0 \end{matrix}$ s
Over	Up to	
–	0,5	15
0,5	1,0	20
1,0	1,5	25
1,5	2,0	35
2,0	2,5	45
2,5	3,0	55
3,0	3,5	65
3,5	4,0	75
4,0	4,5	85
4,5	5,0	130
5,0	5,5	200
5,5	6,0	300
6,0	–	500

*After the conclusion of the test, and after any burning of the sample has ceased, the surface of the sample is wiped clean by rubbing with a piece of cloth soaked with water.*

**13.1.3.2.4** *All three samples shall pass the test.*

*The sample is deemed to have passed the test if it does not ignite.*

*The sample is deemed to have passed the test if it does ignite but all of the following are met:*

- *flaming or glowing of the sample is extinguished within 30 s after removal of the test flame,*
- *the tissue paper does not ignite,*



- *after extinction of the flaming or glowing of the sample, there is no evidence of burning or charring within 50 mm of the lower extremity of the upper clamp.*

#### **13.1.4 Additional reaction to fire characteristics**

Under consideration.

In Australia conduits and conduit fittings classified as low acid gas emission shall be tested in accordance with IEC 60754-1, evolve not more than the equivalent of 5 mg of hydrochloride-acid per gram of sample.

In Austria conduits and conduit fittings classified as low acid gas emission shall be tested in accordance with IEC 60754-2.

### **13.2 Resistance to fire**

Not applicable.

NOTE Required only for fire-resistant conduits for survival circuits.

## **14 External influences**

### **14.1 Degree of protection provided by enclosure**

#### **14.1.1 General**

Conduit systems, when assembled in accordance with the manufacturer's instructions, shall have adequate resistance to external influences according to the classification declared by the manufacturer, with a minimum requirement of IP30.

*Compliance is checked by the tests given in 14.1.1 and 14.1.2.*

#### **14.1.2 Degree of protection – Ingress of foreign solid objects**

**14.1.2.1** *An assembly is made of conduit and conduit fittings using all conduit entries. Where necessary, any open ends of the assembly are plugged, or are not part of the test.*

**14.1.2.2** *The assembly shall be tested in accordance with the appropriate test of IEC 60529. For numeral 5, category 2 applies.*

**14.1.2.3** *The assembly, tested for numeral 5 or 6, shall be deemed to have passed the test if there is no ingress of dust visible to normal or corrected vision without magnification.*

#### **14.1.3 Degree of protection – Ingress of water**

**14.1.3.1** *An assembly is made of conduit and conduit fittings using all conduit entries. Where necessary, any open ends of the assembly are plugged, or are not part of the test.*

**14.1.3.2** *The assembly shall be tested in accordance with the appropriate test of IEC 60529. For numerals 3 and 4, the oscillating tube shall be used.*

**14.1.3.3** *The assembly, tested for numeral 1 and above, shall be deemed to have passed the test if there is not sufficient ingress of water to form a drop visible to normal or corrected vision without magnification.*



## 14.2 Resistance against corrosion

**14.2.1** Metallic and composite conduit systems, excluding screw threads, shall have adequate resistance against corrosion, both inside and outside, in accordance with the classification given in Table 10.

**Table 10 – Resistance to corrosion classification**

Classification	Protection afforded	Example
1	Low protection, inside and outside	Priming paint
2	Medium protection, inside and outside	Stove enamel/electro zinc plate/air drying paint
3	Medium/High composite protection inside: class 2 outside: class 4	Stove enamel Sherardizing
4	High protection, inside and outside	Hot dip zinc coating Sherardizing Stainless steel

*Compliance for painted and zinc coated steel and steel composite conduits and conduit fittings is checked by the tests in 14.2.2.*

For non-ferrous metallic and composite conduit systems, the manufacturer shall provide information about its protection against corrosion.

**14.2.2** Tests for resistance to corrosion for painted and zinc coated steel and steel composite conduits systems.

**14.2.2.1** *Low protection conduit and conduit fittings shall be inspected for completeness of covering by the protective coating, both inside and outside.*

**14.2.2.2** *Medium protection conduit and conduit fittings shall be cleaned with a piece of wadding soaked in white spirit with a kauri-butanol value of 35 + 5 .*

*They shall then be totally immersed in a solution of 0,75 % potassium ferricyanide  $[K_3Fe(CN)_6]$  and 0,25 % ammonium persulphate  $[(NH_4)_2S_2O_8]$  in water and a quantity of about 0,1 % of a suitable wetting agent, for instance a sodium salt of an alkylnaphthaline sulphonic acid, shall be added.*

*The solution and the samples shall be maintained at a temperature of  $(23 \pm 2)$  °C.*

*Each sample shall be tested separately, a fresh solution being used each time.*

*After immersion for  $5 \text{ min } +5_0 \text{ s}$ , the samples shall be removed from the solution and left to dry at ambient temperature in air. After completion of the test as described above, the samples shall show no more than two blue coloured spots on each square centimetre of the surface, and no blue spot shall have a dimension larger than 1,5 mm. Traces of rust on sharp edges, screw threads and machined surfaces, also any yellowish film removable by rubbing, shall be ignored.*

**14.2.2.3** *High protection conduit and conduit fittings shall be degreased by immersion in white spirit with a kauri-butanol value of  $35 + 5$  for  $10 \text{ min}^{+5}_0$  s and wiped dry with a piece of soft cloth. They shall then be immersed in a 2 % solution of sulphuric acid in water for 15 s, thoroughly cleaned in running water and again wiped dry with a piece of clean soft cloth. Each sample shall then be totally immersed in a solution of copper sulphate ( $\text{CuSO}_4 \cdot 5\text{H}_2\text{O}$ ) in distilled water, having a specific gravity of 1,186 kg/l at  $(23 \pm 2)$  °C.*

*The solution and the samples shall be maintained at a temperature of  $(23 \pm 2)$  °C, without stirring.*

NOTE The solution is made by dissolving 360 g of crystalline copper sulphate in 1 l of distilled water and neutralising with copper carbonate or copper hydroxide (about 1 g/l). The specific gravity is then checked and adjusted as necessary.

*The container shall be such that it will not react with the solution and it shall be of such a size as to provide clearance of at least 25 mm between the walls thereof and the sample.*

*Each sample shall be immersed four times in succession in the same solution, each time for  $1 \text{ min}^{+5}_0$  s. A fresh solution shall be used for each sample. After each immersion, the sample shall immediately be cleaned in running water with a brush to remove any black deposit. The sample shall then be wiped dry with a piece of clean soft cloth, and, except after the fourth immersion, returned to the solution. Care should be taken to clean out all holes and pockets.*

*After the test, the sample shall show no precipitation of copper which cannot be scrubbed off in running water, if necessary after immersion for 15 s in a 10 % solution of hydrochloric acid in water.*

*Traces of copper precipitation on screw threads, sharp edges and machined surfaces may be ignored.*

## **15 Electromagnetic compatibility**

Products covered by this standard are, in normal use, passive in respect of electromagnetic influences (emission and immunity).

NOTE When products covered by this standard are installed as part of a wiring installation, the installation may emit, or may be influenced by, electromagnetic signals. The degree of influence will depend on the nature of the installation within its operating environment and the apparatus connected by the wiring.

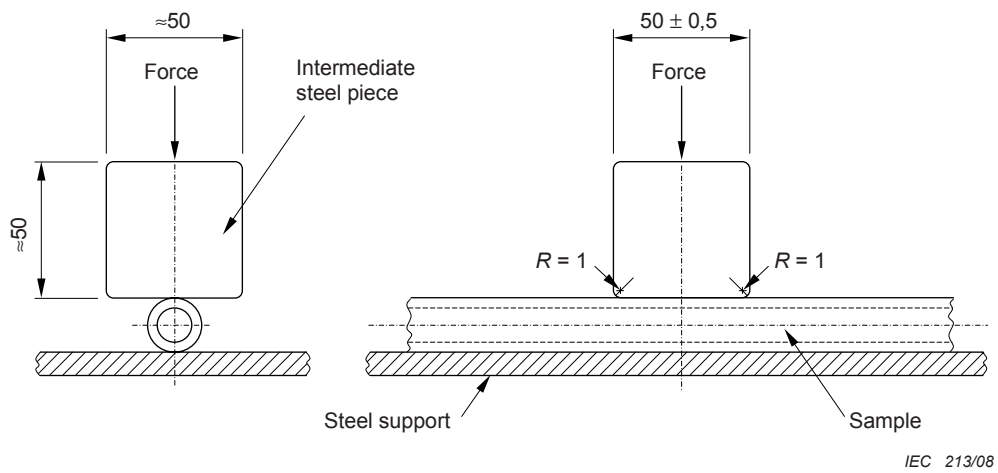

Dimensions in millimetres

Figure 1 – Arrangement for compression test

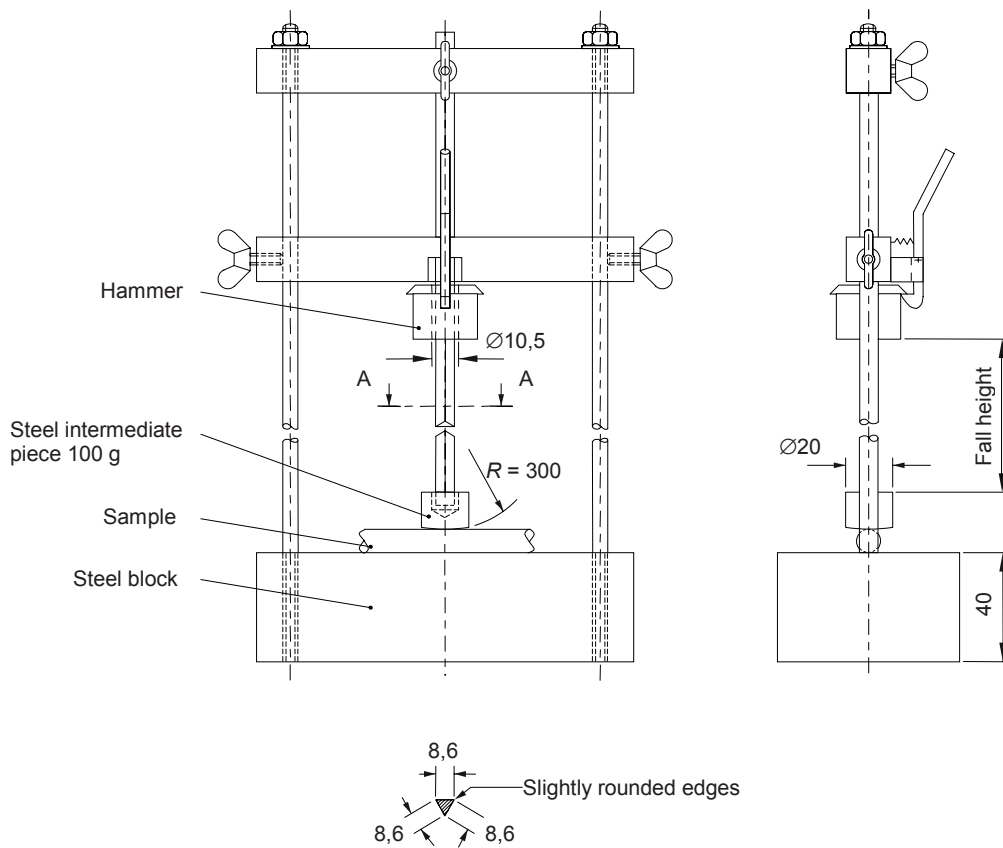

Dimensions in millimetres

NOTE This drawing is not intended to govern design, except as regards the dimensions shown.

Figure 2 – Impact test apparatus

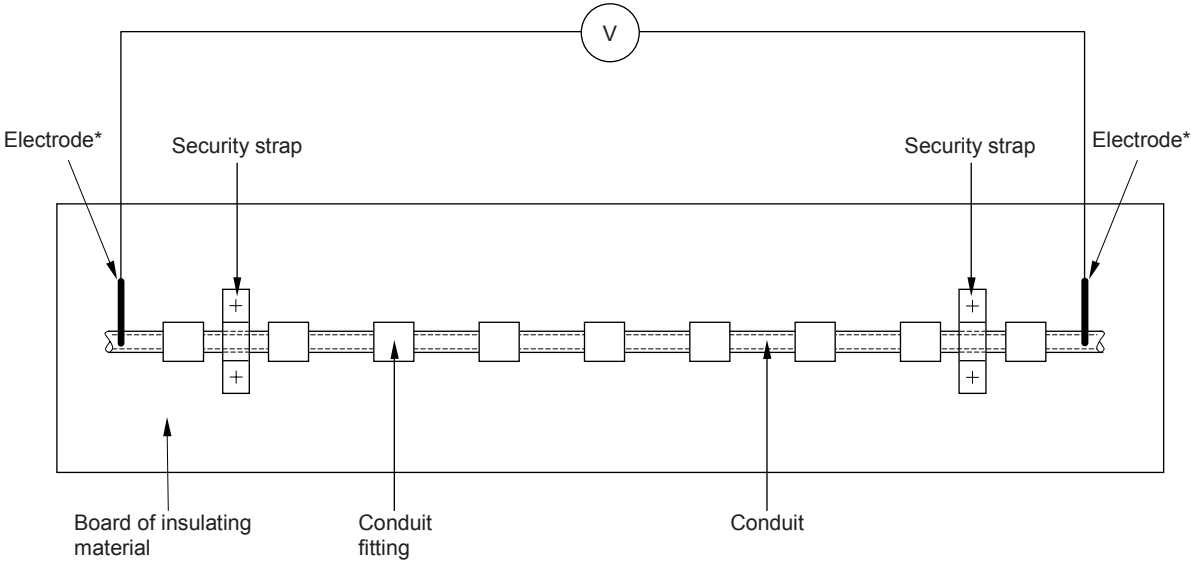

\*Protective coating to be removed to provide direct metal connection for electrodes

IEC 215/08

Figure 3 – Assembly of conduit and conduit fitting for bonding test

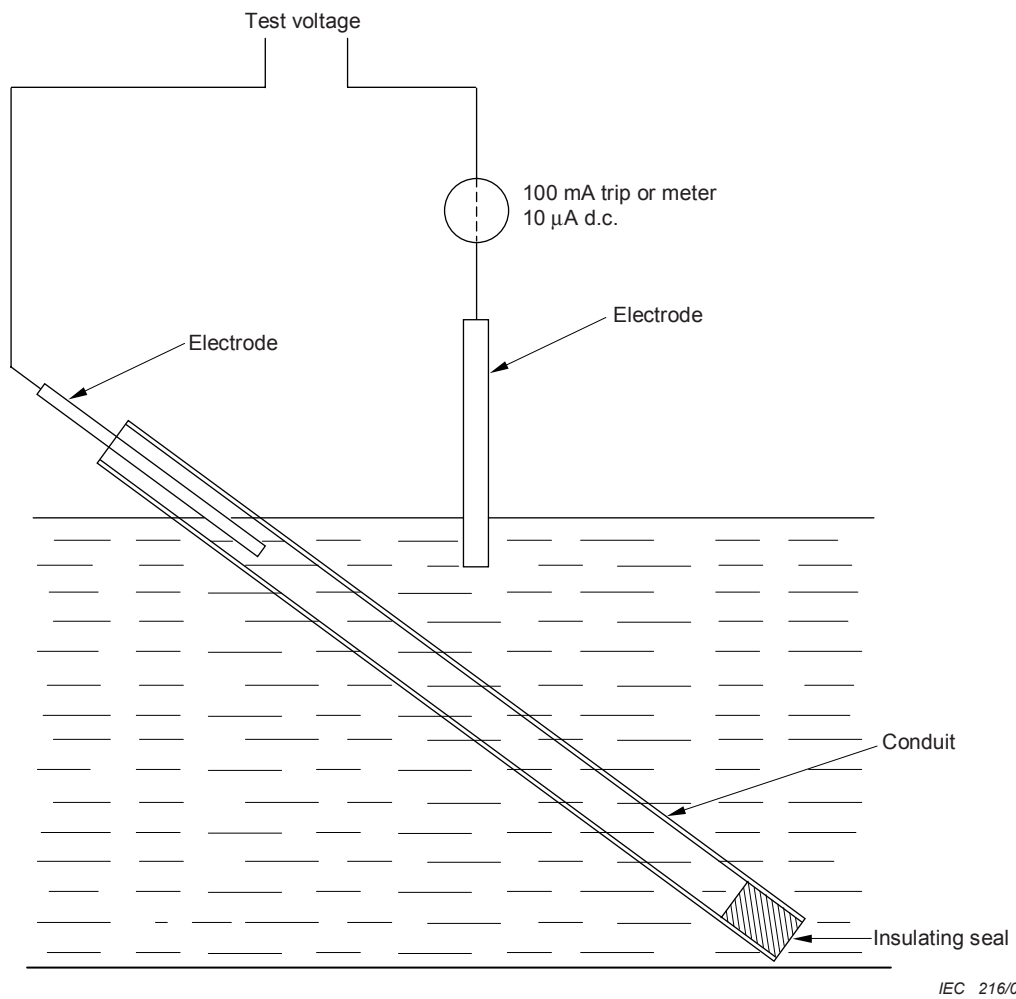

NOTE Remove sharp edges and burrs.

**Figure 4 – Arrangement for dielectric strength and insulation resistance tests – Rigid conduit**

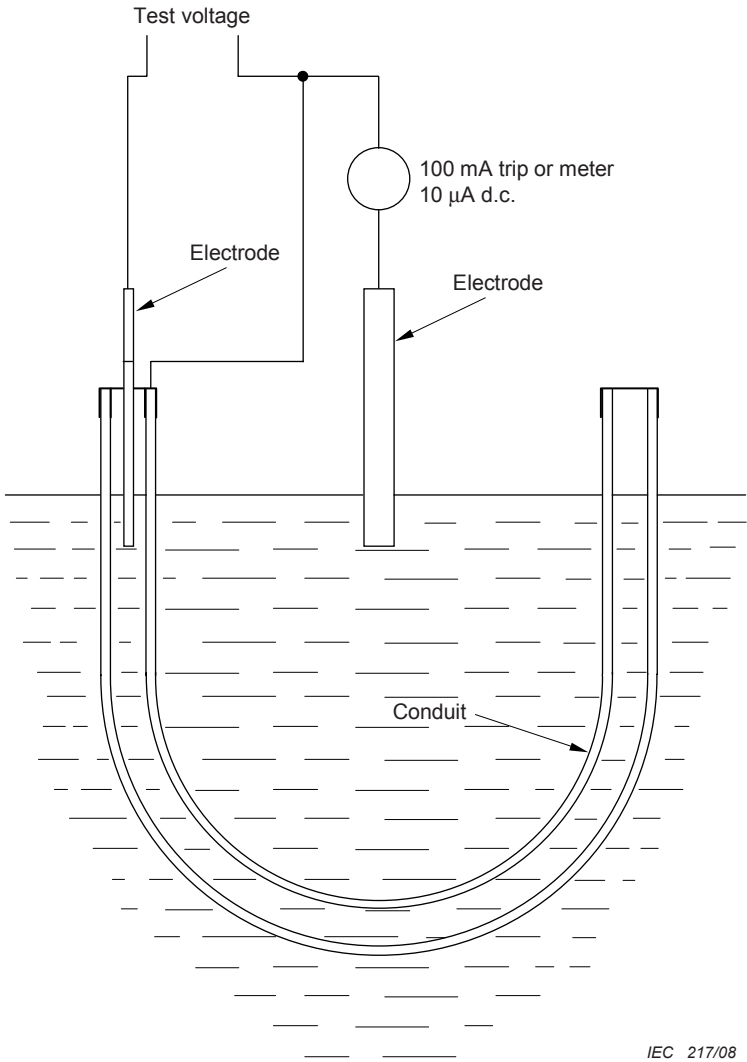

NOTE Remove sharp edges and burrs.

**Figure 5 – Arrangement for dielectric strength and insulation resistance tests – Pliable and flexible conduit**

Licensed copy: Lee Shau Kee Library, HKUST, Version correct as of 03/01/2015, (c) The British Standards Institution 2013

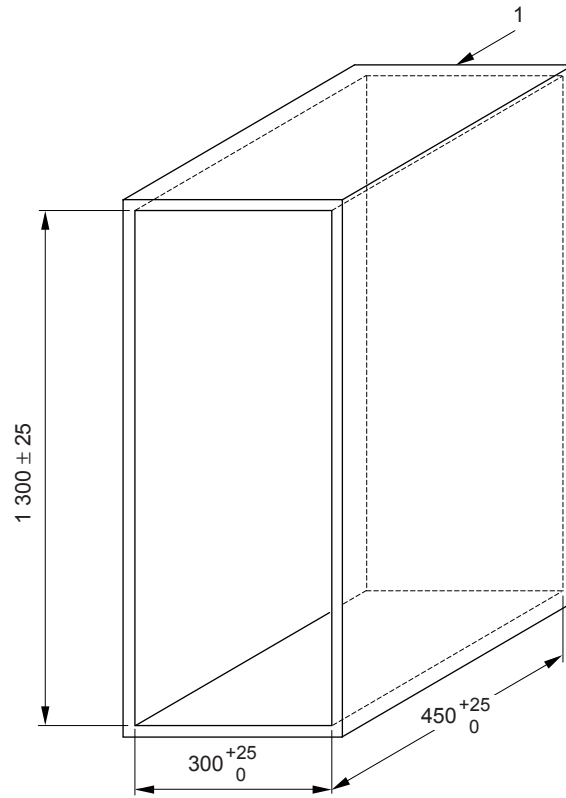

IEC 218/08

Dimensions in millimetres

**Key**

1 Closed back face

NOTE This drawing is not intended to govern design except as regards the dimensions shown.

**Figure 6 – Steel enclosure for test for resistance to flame propagation**

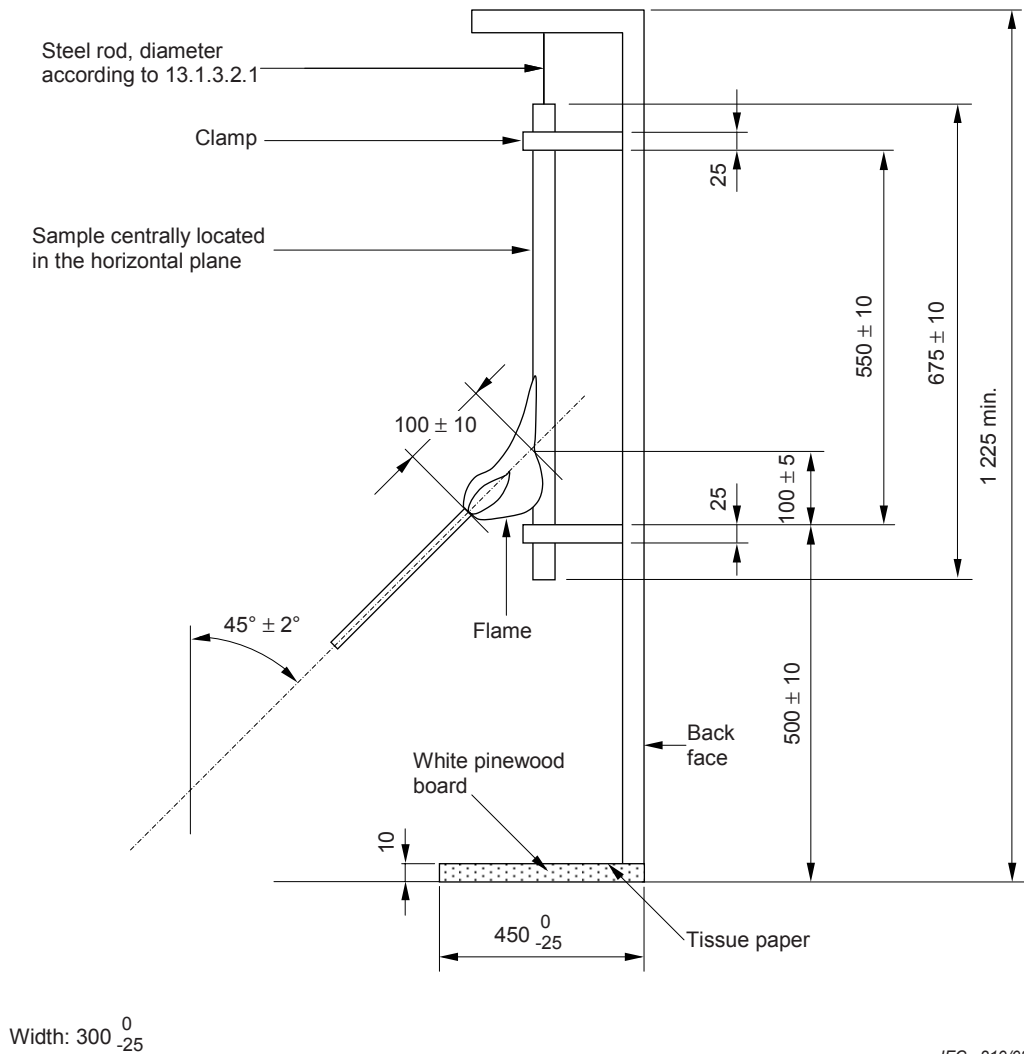

Dimensions in millimetres

NOTE This drawing is not intended to govern design except as regards the dimensions shown.

**Figure 7 – Test arrangement for resistance to flame propagation**



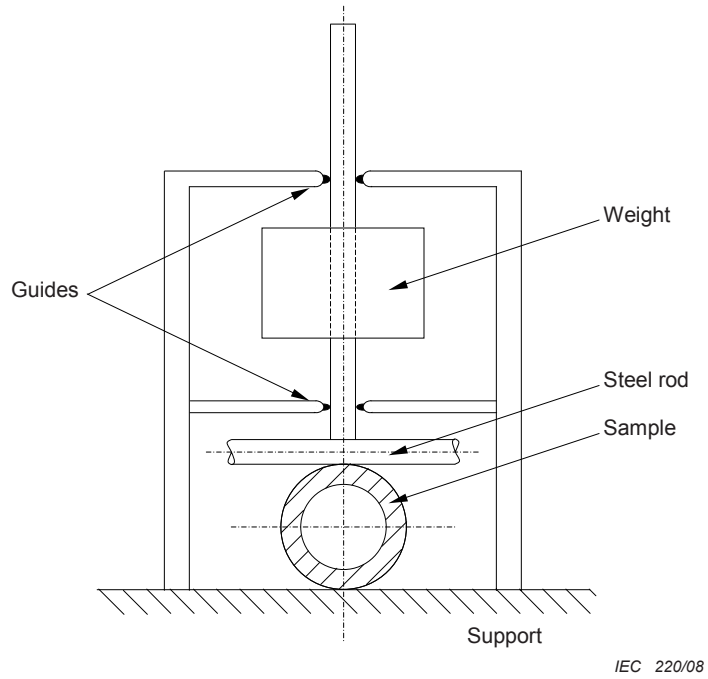

Figure 8 – Test apparatus for resistance to heat

## Annex A (normative)

### Classification coding for conduit systems

NOTE Annex A shows the classification coding format for declared properties of the conduit system, which may be incorporated in the manufacturer's literature.

<b>First digit – Resistance to compression (see 6.1.1)</b>	
Very light compression strength	1
Light compression strength	2
Medium compression strength	3
Heavy compression strength	4
Very heavy compression strength	5

<b>Second digit – Resistance to impact (see 6.1.2)</b>	
Very light impact strength	1
Light impact strength	2
Medium impact strength	3
Heavy impact strength	4
Very heavy impact strength	5

<b>Third digit – Lower temperature range (see 6.2.1)</b>	
+5 °C	1
-5 °C	2
-15 °C	3
-25 °C	4
-45 °C	5

<b>Fourth digit – Upper temperature range (see 6.2.2)</b>	
+60 °C	1
+90 °C	2
+105 °C	3
+120 °C	4
+150 °C	5
+250 °C	6
+400 °C	7

<b>Fifth digit – Resistance to bending (see 6.1.3)</b>	
Rigid	1
Pliable	2
Pliable / self recovering	3
Flexible	4

<b>Sixth digit – Electrical characteristics (see 6.3)</b>	
None declared	0
With electrical continuity characteristics	1
With electrical insulating characteristics	2
With electrical continuity and insulating characteristics	3

<b>Seventh digit – Protection against ingress of solid objects (see 6.4.1)</b>	
Protected against solid foreign objects of 2,5 mm diameter and greater	3
Protected against solid foreign objects of 1,0 mm diameter and greater	4
Dust protected	5
Dust-tight	6

<b>Eighth digit – Protection against ingress of water (see 6.4.2)</b>	
None declared	0
Protected against vertically falling water drops	1
Protected against vertically falling water drops when the conduit system is tilted up to an angle of 15°	2
Protected against spraying water	3
Protected against splashing water	4
Protected against water jets	5
Protected against powerful water jets	6
Protected against the effects of temporary immersion in water	7

<b>Ninth digit – Resistance against corrosion (see 6.4.3 and Table 10)</b>	
Low protection inside and outside	1
Medium protection inside and outside	2
Medium protection inside, high protection outside	3
High protection inside and outside	4

<b>Tenth digit – Tensile strength (see 6.1.4)</b>	
None declared	0
Very light tensile strength	1
Light tensile strength	2
Medium tensile strength	3
Heavy tensile strength	4
Very heavy tensile strength	5

<b>Eleventh digit – Resistance to flame propagation (see 6.5)</b>	
Non-flame propagating	1
Flame propagating	2

<b>Twelfth digit – Suspended load capacity (see 6.1.5)</b>	
None declared	0
Very light suspended load capacity	1
Light suspended load capacity	2
Medium suspended load capacity	3
Heavy suspended load capacity	4
Very heavy suspended load capacity	5

Thirteenth digit – Fire effects

Under consideration.

**Annex B**  
(normative)

**Determination of material thickness**

**B.1 Material thickness of plain conduit**

Measurements of the material thickness are taken at four places, approximately equally spaced around 360° of the conduit, and the mean value calculated as follows:

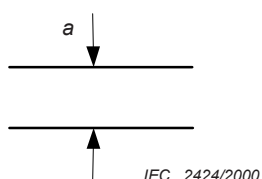

$$\frac{\sum_4^1 a}{4} = \text{mean material thickness}$$

**B.2 Material thickness of corrugated conduit**

Measurements of the material thickness are taken at the root and the crest of the corrugation at four places, approximately equally spaced, around 360° of the conduit, and the mean value calculated as follows:

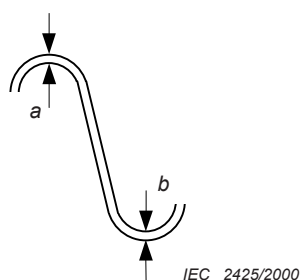

$$\frac{\sum_4^1 [a+b]}{8} = \text{mean material thickness}$$

**B.3 Material thickness of combined plain conduit and corrugated conduit**

Measurements of the material thickness are taken at the root and the crest of the corrugation and plain section at four places, approximately equally spaced, around 360° of the conduit, and the mean value calculated as follows:

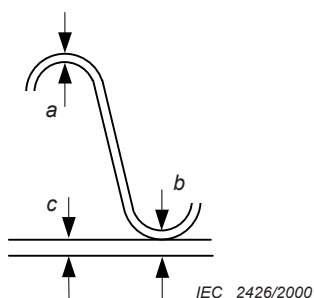

$$\frac{\sum_4^1 [b+(a+c)]}{8} = \text{mean material thickness}$$

**B.4 Material thickness of combined plain conduit, corrugated conduit and plain conduit**

Measurements of the material thickness are taken at the root and crest of the corrugation and plain section at four places, approximately equally spaced, around 360° of the conduit and the mean value calculated as follows:

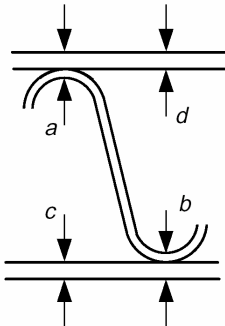

$$\frac{\sum_4^1 [(a+c)+(b+d)]}{8} = \text{mean material thickness}$$

## Bibliography

IEC 60670 (all parts), *Boxes and enclosures for electrical accessories for household and similar fixed electrical installations*

NOTE Harmonized in EN 60670 series (modified).

IEC 60754-1, *Test on gases evolved during combustion of materials from cables – Part 1: Determination of the amount of halogen acid gas*

NOTE See EN 50267 series, *Common test methods for cables under fire conditions - Tests on gases evolved during combustion of materials from cables* .

IEC 60754-2, *Test on gases evolved during combustion of electric cables – Part 2: Determination of degree of acidity of gases evolved during the combustion of materials taken from electric cables by measuring pH and conductivity*

NOTE See EN 50267 series, *Common test methods for cables under fire conditions - Tests on gases evolved during combustion of materials from cables* .

---

## Annex ZA (normative)

### Normative references to international publications with their corresponding European publications

The following referenced documents are indispensable for the application of this document. For dated references, only the edition cited applies. For undated references, the latest edition of the referenced document (including any amendments) applies.

NOTE When an international publication has been modified by common modifications, indicated by (mod), the relevant EN/HD applies.

<u>Publication</u>	<u>Year</u>	<u>Title</u>	<u>EN/HD</u>	<u>Year</u>
IEC 60417	Data-base	Graphical symbols for use on equipment	-	-
IEC 60423	2007	Conduit systems for cable management - Outside diameters of conduits for electrical installations and threads for conduits and fittings	EN 60423	2007
IEC 60529	1989	Degrees of protection provided by enclosures (IP Code)	EN 60529 + corr. May	1991 1993
A1	1999		A1	2000
IEC 60695-2-11	2000	Fire hazard testing - Part 2-11: Glowing/hot-wire based test methods - Glow-wire flammability test method for end-products	EN 60695-2-11	2001
IEC 60695-11-2	2003	Fire hazard testing - Part 11-2: Test flames - 1 kW nominal pre-mixed flame - Apparatus, confirmatory test arrangement and guidance	EN 60695-11-2	2003



**Annex ZB**  
(normative)

**Special national conditions**

**Special national condition:** National characteristic or practice that cannot be changed even over a long period, e.g. climatic conditions, electrical earthing conditions.

NOTE If it affects harmonization, it forms part of the European Standard / Harmonization Document.

For the countries in which the relevant special national conditions apply these provisions are normative, for other countries they are informative.

Clause      Special national condition

**6.5.2**      **Austria**

Conduits and conduit fittings may be classified with low acid gas emission.

**13.1.4**      **Austria**

Conduits and conduit fittings classified as low acid gas emission shall be tested in accordance with EN 50267-1 and EN 50267-2-2.

---

---

---

## British Standards Institution (BSI)

BSI is the independent national body responsible for preparing British Standards. It presents the UK view on standards in Europe and at the international level. It is incorporated by Royal Charter.

### Revisions

British Standards are updated by amendment or revision. Users of British Standards should make sure that they possess the latest amendments or editions.

It is the constant aim of BSI to improve the quality of our products and services. We would be grateful if anyone finding an inaccuracy or ambiguity while using this British Standard would inform the Secretary of the technical committee responsible, the identity of which can be found on the inside front cover.  
Tel: +44 (0)20 8996 9000 Fax: +44 (0)20 8996 7400

BSI offers members an individual updating service called PLUS which ensures that subscribers automatically receive the latest editions of standards.

### Buying standards

Orders for all BSI, international and foreign standards publications should be addressed to Customer Services.

Tel: +44 (0)20 8996 9001 Fax: +44 (0)20 8996 7001

Email: [orders@bsigroup.com](mailto:orders@bsigroup.com)

You may also buy directly using a debit/credit card from the BSI Shop on the Website <http://www.bsigroup.com/shop>.

In response to orders for international standards, it is BSI policy to supply the BSI implementation of those that have been published as British Standards, unless otherwise requested.

### Information on standards

BSI provides a wide range of information on national, European and international standards through its Library and its Technical Help to Exporters Service. Various BSI electronic information services are also available which give details on all its products and services. Contact the Information Centre.

Tel: +44 (0)20 8996 7111 Fax: +44 (0)20 8996 7048

Email: [info@bsigroup.com](mailto:info@bsigroup.com)

Subscribing members of BSI are kept up to date with standards developments and receive substantial discounts on the purchase price of standards. For details of these and other benefits contact Membership Administration.

Tel: +44 (0)20 8996 7002 Fax: +44 (0)20 8996 7001

Email: [membership@bsigroup.com](mailto:membership@bsigroup.com)

Information regarding online access to British Standards via British Standards Online can be found at <http://www.bsigroup.com/BSOL>.

Further information about BSI is available on the BSI website at <http://www.bsigroup.com>.

### Copyright

Copyright subsists in all BSI publications. BSI also holds the copyright, in the UK, of the publications of the international standardization bodies. Except as permitted under the Copyright, Designs and Patents Act 1988 no extract may be reproduced, stored in a retrieval system or transmitted in any form or by any means – electronic, photocopying, recording or otherwise – without prior written permission from BSI.

This does not preclude the free use, in the course of implementing the standard, of necessary details such as symbols, and size, type or grade designations. If these details are to be used for any other purpose than implementation then the prior written permission of BSI must be obtained.

Details and advice can be obtained from the Copyright & Licensing Manager.

Tel: +44 (0)20 8996 7070 Email: [copyright@bsigroup.com](mailto:copyright@bsigroup.com)